



MCB167-NET Evaluation Board

**High-Speed Microcontroller Board
for Infineon 167 and ST10-167/168 Variants
with Dual CAN and Ethernet Controllers**

User's Guide 07.2000

Information in this document is subject to change without notice and does not represent a commitment on the part of the manufacturer. The software described is furnished under license or nondisclosure agreement and may be used or copied only in accordance with the terms of the agreement. It is against the law to copy software on any medium except as specifically allowed in the license or nondisclosure agreement. The purchaser may make one copy of the software for backup purposes. No part of this manual may be reproduced or transmitted in any form or by any means, electronic or mechanical, including photocopying, recording, or information storage and retrieval systems, for any purpose other than the purchaser's personal use, without written permission.

Copyright © 1993-2000 Keil Elektronik GmbH and Keil Software, Inc.
All rights reserved.

Keil C166™ and μ Vision2™ are trademarks of Keil Elektronik GmbH.
Microsoft® and Windows™ are trademarks or registered trademarks of Microsoft Corporation.

Every effort was made to ensure accuracy in this manual and to give appropriate credit to persons, companies, and trademarks referenced herein.

Preface

This manual describes the Keil Software MCB167-NET Evaluation Board and the Keil 166 microcontroller software development tools. The following chapters are included.

“Chapter 1. Introduction” gives an overview of this user’s guide and provides a quick start index.

“Chapter 2. Setup” describes how to connect and configure the MCB167-NET Evaluation Board and provides detailed information about the DIP switches and configuration jumpers.

“Chapter 3. Hardware” provides detailed information about the hardware design including the schematic drawings for the MCB167-NET board and logic equations for the PLD.

“Chapter 4. Programming” provides details about how to use the Keil embedded development tools to generate programs for the MCB167-NET Evaluation Board.

NOTE

This manual assumes that you are familiar with Microsoft Windows and the hardware and instruction set of the 166/167 microcontroller family.

Contents

Chapter 1. Introduction	5
Quick Start	6
Chapter 2. Setup	7
Using the MCB167-NET	7
Configuring the MCB167-NET	8
DIP Switches	9
Configuration Jumpers	11
Chapter 3. Hardware	13
PAL Equations	17
Schematics	18
Printed Board Assembly	22
Technical Data	23
Pin-Out of Port Signals	23
Chapter 4. Programming	25
Writing Programs for the MCB167-NET Boars	25
BLINKY Example Program	28
Other Example Programs	29
Application Notes	29
Index	31

Chapter 1. Introduction

Thank you for choosing Keil Software and the MCB167-NET Evaluation Board for the 166/ST10 microcontroller family. This kit allows you to generate code you can run on the MCB167-NET Evaluation Board. This hands-on process helps you determine hardware and software needs for current and future product development.

The MCB167-NET Evaluation Board is compatible with all variants of the Infineon C167 and ST10-167/168 microcontrollers. It supports the single and dual on-chip CAN controllers available in many devices. In addition, an Ethernet controller, using the Crystal LAN CS8900A, is provided. You may use a TCP/IP stack with the MCB167-NET to connect to the Internet via a standard 10BASET 10Mbit Ethernet connection.

Several program examples are provided:

- A simple test program that flashes the LEDs,
- A program that writes “Hello World” to the serial port,
- and A measurement recording system.

TCP/IP stack implementations for the RTX-166 real-time operating system are available from:

- ARS Software (www.ars2000.com),
- CMX Company (www.cmx.com),
- and US Software (www.ussw.com).

This user's guide describes the hardware of the MCB167-NET Evaluation Board and contains basic operating instructions for the monitor program (Monitor-166) and the μ Vision2 debugger. The monitor programs allows your PC to communicate with the MCB167-NET Evaluation Board and allows you to download and run your 166/167 programs.

The MCB167-NET kit includes the following items:

- MCB167-NET Evaluation Board User's Guide (this manual),
- MCB167-NET Evaluation Board,
- CD-ROM which includes an evaluation version of the Keil C166 compiler and example programs for the MCB167-NET Evaluation Board,
- and a 9-pin Serial Cable.

Quick Start

Use the following table to quickly locate important information about the MCB167-NET Evaluation Board.

To...	See...
Connect power to the MCB167-NET board.	"Using the MCB167-NET" on page 7.
Connect the MCB167-NET to your PC.	"Using the MCB167-NET" on page 7.
Read about the default configuration settings.	"Configuring the MCB167-NET" on page 8.
Configure the tool options for the MCB167-NET board.	"Writing Programs for the MCB167-NET" on page 25.
Create a simple program to blink the LEDs.	"BLINKY Example Program" on page 28.
Write code to use the Ethernet controller.	"Other Example Programs" on page 29.
Learn more about the μ Vision2 IDE.	"Writing Programs for the MCB167-NET" on page 25.
Read about the DIP switch settings.	"DIP Switches" on page 9.
Read about the configuration jumpers.	"Configuration Jumpers" on page 11.
See the MCB167-NET schematics.	"Schematics" on page 18.
See the MCB167-NET PAL equations.	"PAL Equations" on page 17.

Chapter 2. Setup

The MCB167-NET Evaluation Board requires power and a serial connection to a PC running the μ Vision2 Debugger with the Monitor-166 driver. Before you start, make sure you have satisfied the following hardware and software requirements.

Hardware/Software Requirements

- A PC running Microsoft Windows 95/98/NT/2000 with an available COM port.
- The Keil C166 tool chain with the μ Vision2 Debugger and Monitor-166 driver. A pre-configured Monitor for the MCB167-NET board is included in Keil C166 Version 4.06 and higher. This package also contains several example programs for the MCB167-NET board.

Using the MCB167-NET

To use the MCB167-NET Evaluation Board, you must:

- Connect the external serial port jack (COM) to a COM port on your PC using the supplied serial cable.
- Connect power to the board using a 9VDC, 500mA power supply.

The serial cable allows your PC to download program code so you can test and debug your target applications. The power cable provides power to the MCB167-NET Evaluation Board. The MCB167-NET does not get power from the PC via the serial cable.

The following illustration shows MCB167-NET board and the important interface and hardware components.

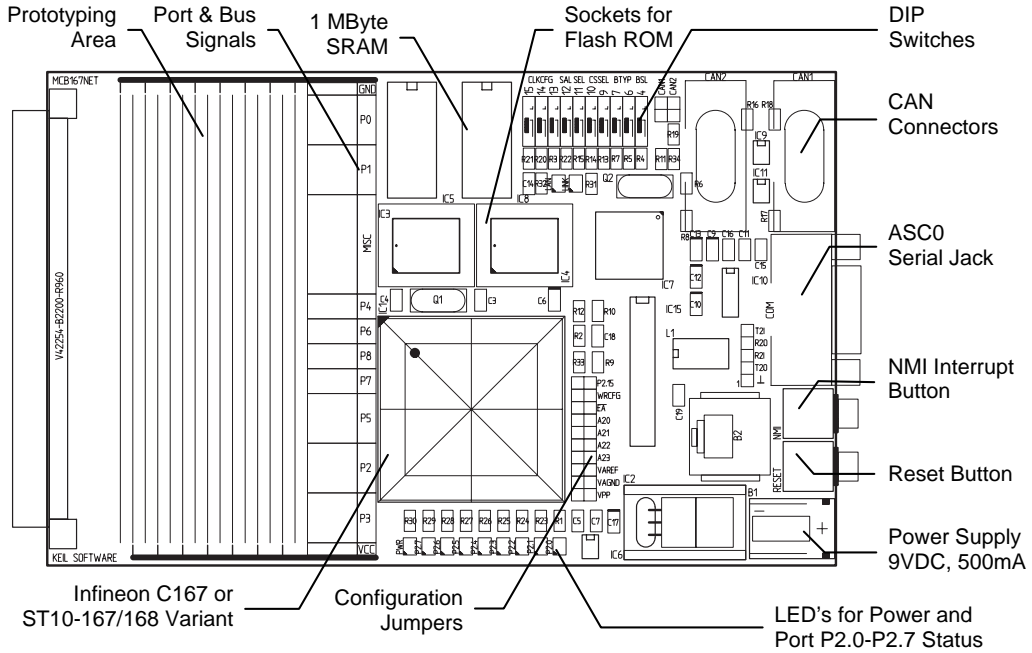

Configuring the MCB167-NET

The MCB167-NET Evaluation Board is configured using DIP switches and configuration jumpers and is shipped with the following configuration:

- 20 MHz internal CPU clock, 3 chip select signals, 4 segment address lines.
- Bootstrap loader enabled (for downloading the debug monitor).
- CAN drivers and CAN bus termination resistors enabled.
- 5V reference for the A/D converter enabled.

The default DIP switch settings are shown in the following table.

Switch	CLKCFG	SALSEL	CSEL	BTYP	BSL
ON	X	X	X	X	X
OFF	X	X		X	

DIP Switches

The following sections describe the DIP switches on the MCB167-NET board.

CLKCFG (Default: OFF ON OFF)

The **CLKCFG** DIP switches configure the internal CPU clock. The 167 device uses an on-chip PLL that generates the internal CPU clock from the external 10MHz XTAL. The following table shows the possible internal CPU clock speeds for a standard 10MHz crystal. Check the datasheet for the device you use to determine the maximum possible internal CPU clock speed.

15	14	13	Internal CPU Clock	Note
OFF	OFF	OFF	10MHz × 4.0 = 40MHz	
OFF	OFF	ON	10MHz × 3.0 = 30MHz	
OFF	ON	OFF	10MHz × 2.0 = 20MHz	Default setting
OFF	ON	ON	10MHz × 5.0 = 50MHz	
ON	OFF	OFF	10MHz × 1.0 = 10MHz	Direct drive, on-chip PLL is disabled
ON	OFF	ON	10MHz × 1.5 = 15MHz	Only possible on some CPU variants
ON	ON	OFF	10MHz × 0.5 = 5MHz	Only possible on some CPU variants
ON	ON	ON	10MHz × 2.5 = 25MHz	Only possible on some CPU variants

SALSEL (Default: ON ON)

The **SALSEL** DIP switches define the number of active segment address lines on Port 4. If you use the CAN interface, only A19-A16 may be enabled since the other Port 4 pins are used for CAN I/O. Even if some segment address lines are disabled, the C167 internally uses a complete 24-bit address. The full address space can be still used via the **CS/** (chip select) signals.

12	11	Segment Address Lines	Directly Accessible Address Space
OFF	OFF	Two: A17 and A16	256 KByte
OFF	ON	Eight: A23-A16	16 MByte
ON	OFF	None	64 KByte
ON	ON	Four: A19-A16	1 MByte (default setting)

CSSEL (Default: ON ON)

The CSSEL DIP switches define the number of active chip select signals. The CS/ signals are generated on Port 6 and used as chip select lines for the RAM, Flash ROM and Ethernet devices on the MCB167-NET board.

10	9	Segment Address Lines	Note
OFF	OFF	Five: CS4-CS0	Provides two additional user CS lines.
OFF	ON	None	All Port 6 pins are available. This requires board modification.
ON	OFF	Two: CS1-CS0	
ON	ON	Three: CS2-CS0	Default setting for the MCB167-NET Board.

BTYP (Default: OFF ON)

The BTYP DIP switches select the external bus type. The MCB167-NET board uses a demultiplexed 16-bit address bus. Therefore, the bus type of the MCB167-NET cannot be changed without extensive modification to the hardware. The following table lists the possible external bus types with the 167 microcontroller.

7	6	External Bus	Note
OFF	OFF	16-bit multiplexed BUS	
OFF	ON	16-bit demultiplexed BUS	Default setting for the MCB167-NET Board
ON	OFF	8-bit multiplexed BUS	
ON	ON	8-bit demultiplexed BUS	

BSL (Default: ON)

The BSL DIP switch, when ON, activates the on-chip bootstrap loader. The bootstrap loader allows you to download the Monitor-166 for program debugging with μ Vision2. Monitor downloading is performed automatically when you start the μ Vision2 debugger. When BSL is OFF, you may use a Monitor programmed into the on-chip ROM of the C167 device.

Configuration Jumpers

The following sections describe each of the configuration jumpers of the MCB167-NET board.

CAN1, CAN2: Default ON

The **CAN1** and **CAN2** configuration jumpers, when in place, terminate each CAN bus interface with a 120 Ω termination resistor. This resistor is required at each end of a CAN bus. Set these jumpers if the MCB167-NET board is the end node of a CAN bus. Remove them if the MCB167-NET is not the end node on a CAN bus.

P2.15: Default ON

The **P2.15** configuration jumper, when in place, provides the interrupt request signal of the Ethernet controller to the **EX7IN** interrupt input of the C167 microcontroller. If you don't use the Ethernet controller, you may remove this jumper.

EA/: Default ON

The **EA/** configuration jumper selects whether the CPU begins executing program code from the on-chip ROM or from external memory. When this jumper is in place (the default configuration), the CPU starts instruction execution from external memory. When the **EA/** jumper is removed, code execution starts from on-chip ROM.

WRCFG: Default ON

The **WRCFG** configuration jumper selects whether the **WR/** and **BHE/** signals act as **WR/** and **BHE/** (when **WRCFG** is removed) or as **WRL/** and **WRH/** (when **WRCFG** is in place). The MCB167-NET board requires the **WRH/** and **WRL/** signals, therefore, this jumper should always be ON.

A20, A21, A22, A23: Default ON

The **A20-A23** configuration jumpers connect the CAN bus drivers (IC9 and IC11) to the C167 CAN interface signals. Remove **A21** and **A22** to disconnect the **CAN1** bus driver. Remove **A20** and **A24** to disconnect the **CAN2** bus driver.

VAREF, VAGND: Default ON

The **VAREF** and **VAGND** jumpers provide the reference voltage for the on-chip A/D converter. When these jumpers are in place, the on-board 5V reference is used. When these jumpers are removed, you must provide the A/D reference voltages to the board.

VPP: Default OFF

The **VPP** jumper determines whether or not pin 84 is connected to **GND** (when the jumper is in place) or to the user-provided Flash programming voltage **VPP** (when the jumper is removed). On some devices, this jumper is used to select the Flash programming voltage. On other devices, this jumper is used to disable the oscillator watchdog. On most devices, this jump not required and is by default OFF. For detailed information about the usage of this jumper refer to the description of pin 84 in chip datasheet of the device used on the board.

Chapter 3. Hardware

The MCB167-NET is designed to be a very flexible evaluation board that you can use for a wide variety of 167 and ST10-167/168 variants. It supports up to two CAN interfaces that can be enabled using jumpers. The MCB167-NET evaluation board can be expanded to support your own hardware prototypes.

This chapter describes logical sections of the MCB167-NET board and provides a circuit description that will help you understand how the MCB167-NET board works and how you can easily interface to the various I/O devices available.

The following block diagram shows the various memory, I/O, configuration, and power systems on the board.

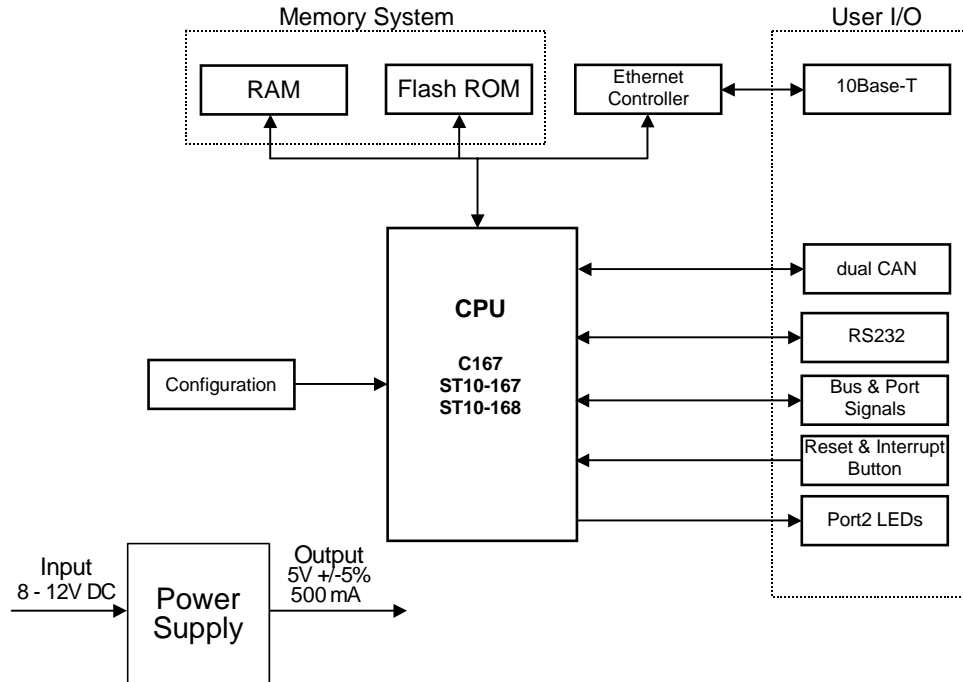

Power Supply

Power is supplied to the MCB167-NET board by an external 8-12 Volt DC power supply which is capable of providing 400-500mA. Connection is made using a standard 5.5mm barrel plug with a 2.5mm center hole. The center hole provides positive voltage. On the board, 5 Volts DC is generated by a 7805

voltage regulator at IC2. To reduce noise for the A/D converter, a second 78L05 voltage regulator at IC6 is used.

C167 Microcontroller

The Infineon C167CR (or C167CS) microcontroller provided with the MCB167-NET board is a high-end 167 device with on-chip CAN. It is located at IC1. The IC1 socket can accommodate numerous variants of the 167 including the ST10-167 and ST10-168 devices. A 10.000 MHz crystal provides the clock signal.

Configuration

The MCB167-NET evaluation board is very flexible. You may change the operation of the board using the DIP switches and the configuration jumpers. Features such as CAN interfaces, chip select and segment address lines, internal CPU clock frequency, on-chip ROM, and Monitor operation can be configured using these switches and jumpers. Refer to “DIP Switches” on page 9 and “Configuration Jumpers” on page 11 for a description of the possible settings.

NOTE

You must RESET the MCB167-NET after changing the state of any DIP switch.

CAN Drivers

The MCB167-NET board supports dual CAN interfaces using SI9200AY CAN drivers (IC9 and IC11) and termination resistors (R18 and R19). The driver settings may be changed by configuration jumpers.

Memory Devices

The MCB167-NET evaluation board provides two high-speed RAM devices (IC5, IC8) and sockets for two Flash ROM devices (IC3, IC4). The chip select signals are provided by the C167 microcontroller. **CS0/** is used for the Flash ROM and **CS1/** is used for the RAM.

Ethernet Interface

The Ethernet controller CS8900A (IC7) is used to interface to the Ethernet connector. The MCB167-NET board provides a standard 10Base-T (10MBit) interface that allows direct connection to most Ethernet networks. The CS2/ chip select from the C167 microcontroller is used to access the Ethernet controller as a memory mapped device.

Decode Logic

All memory address decode logic and signal conversions required for the CS8900A Ethernet controller are performed by the 20V8 PAL (IC15). Refer to "PAL Equations" on page 17 for a listing of the PAL equations.

Status LEDs

The MCB167-NET board has a power LED (PWR), eight LEDs (connected to the Port 2 outputs), and two LEDs (LAN and LINK) for the Ethernet interface.

You may use the Port 2 LEDs to display program status while testing your applications.

The LAN and LINK LEDs show the current status of the Ethernet interface.

Push Buttons

The MCB167-NET provides two buttons: RESET and NMI. RESET is connected to the reset input of the microcontroller. NMI is connected to the NMI (Non-Maskable Interrupt) of the microcontroller. You may generate an NMI signal to stop program execution when you use Monitor-166 for program debugging.

Serial Port

The MCB167-NET supports the ASC0 on-chip serial UART and uses a MAX232 (IC10) to convert the logic signals to RS-232 voltage levels. The ASC0 UART is used in bootstrap mode to download the Monitor-166 program which allows program testing using the μ Vision2 debugger.

Two drivers of the MAX232 (IC10) are pre-wired to use the simulated serial mode of Monitor-166. In simulated serial mode, two standard I/O pins of the 167 microcontroller are used to establish communication between the μ Vision2 debugger and the MCB167-NET board. For this operation the Monitor-166 must be programmed into ROM.

The serial port (COM) is configured as a standard 3-wire interface. The DB9 connector is wired to loop the PC's handshaking signals back to the PC. Refer to the figure at the right for details.

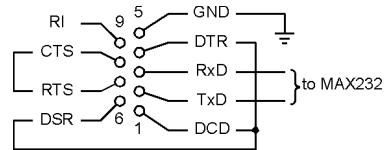

Prototyping Area

A perforated area is provided on the MCB167-NET evaluation board for prototyping your own hardware. All microcontroller signals are brought out to this area. The signals are driven directly by the microcontroller. Exercise caution to avoid overloading these signal lines. Refer to “Pin-Out of Port Signals” on page 23 for the pin-out of the microcontroller and bus signals.

PAL Equations

This following lists the PAL equations for the 20V8 logic device at IC12.

```

;PALASM Design Description

;----- Declaration Segment -----
TITLE    GAL for MCB167NET Prototype board
PATTERN  Decode Logic for Ethernet Controller
REVISION 1.0
AUTHOR   Hans Schneebauer
COMPANY  Keil Elektronik GmbH
DATE     09/30/99

CHIP    IC15  PALCE20V8

;----- PIN Declarations -----
PIN 1      UNUSED1      COMBINATORIAL ; INPUT
PIN 2..6   A[8..12]    COMBINATORIAL ; INPUT
PIN 7      /RD         COMBINATORIAL ; INPUT
PIN 8      /WRL        COMBINATORIAL ; INPUT
PIN 9      /WRH        COMBINATORIAL ; INPUT
PIN 10     /RSTOUT     COMBINATORIAL ; INPUT
PIN 11     /CS2        COMBINATORIAL ; INPUT
PIN 12     GND         ; INPUT
PIN 13     UNUSED2     COMBINATORIAL ; INPUT
PIN 14     UNUSED3     COMBINATORIAL ; INPUT
PIN 15     RESET       COMBINATORIAL ; OUTPUT
PIN 16     /IOW        COMBINATORIAL ; OUTPUT
PIN 17     /IOR        COMBINATORIAL ; OUTPUT
PIN 18     /MEMW       COMBINATORIAL ; OUTPUT
PIN 19     /MEMR       COMBINATORIAL ; OUTPUT
PIN 20     AEN         COMBINATORIAL ; OUTPUT
PIN 21     /REFRESH    COMBINATORIAL ; OUTPUT
PIN 22     /SBHE       COMBINATORIAL ; OUTPUT
PIN 23     UNUSED4     COMBINATORIAL ; INPUT
PIN 24     VCC         ; INPUT

;----- Boolean Equation Segment -----
EQUATIONS

RESET = RSTOUT
SBHE  = WRH + RD
AEN   = 0
REFRESH = 0

IF (A[11..8] = #b0011) THEN ; If in Range 0300H - 03FF -> IO Interface
  BEGIN
    IOR = RD * CS2
    IOW = (WRL + WRH) * CS2
    MEMR = 0 ; MEMR always inactive
    MEMW = 0 ; MEMW always inactive
  END
ELSE ; If in Range 0 - 02FF or 0400 - 0FFF
  BEGIN ; -> Memory Interface
    IOR = 0 ; IOR always inactive
    IOW = 0 ; IOW always inactive
    MEMR = RD * CS2
    MEMW = (WRL + WRH) * CS2
  END
END
;-----

```

Schematics

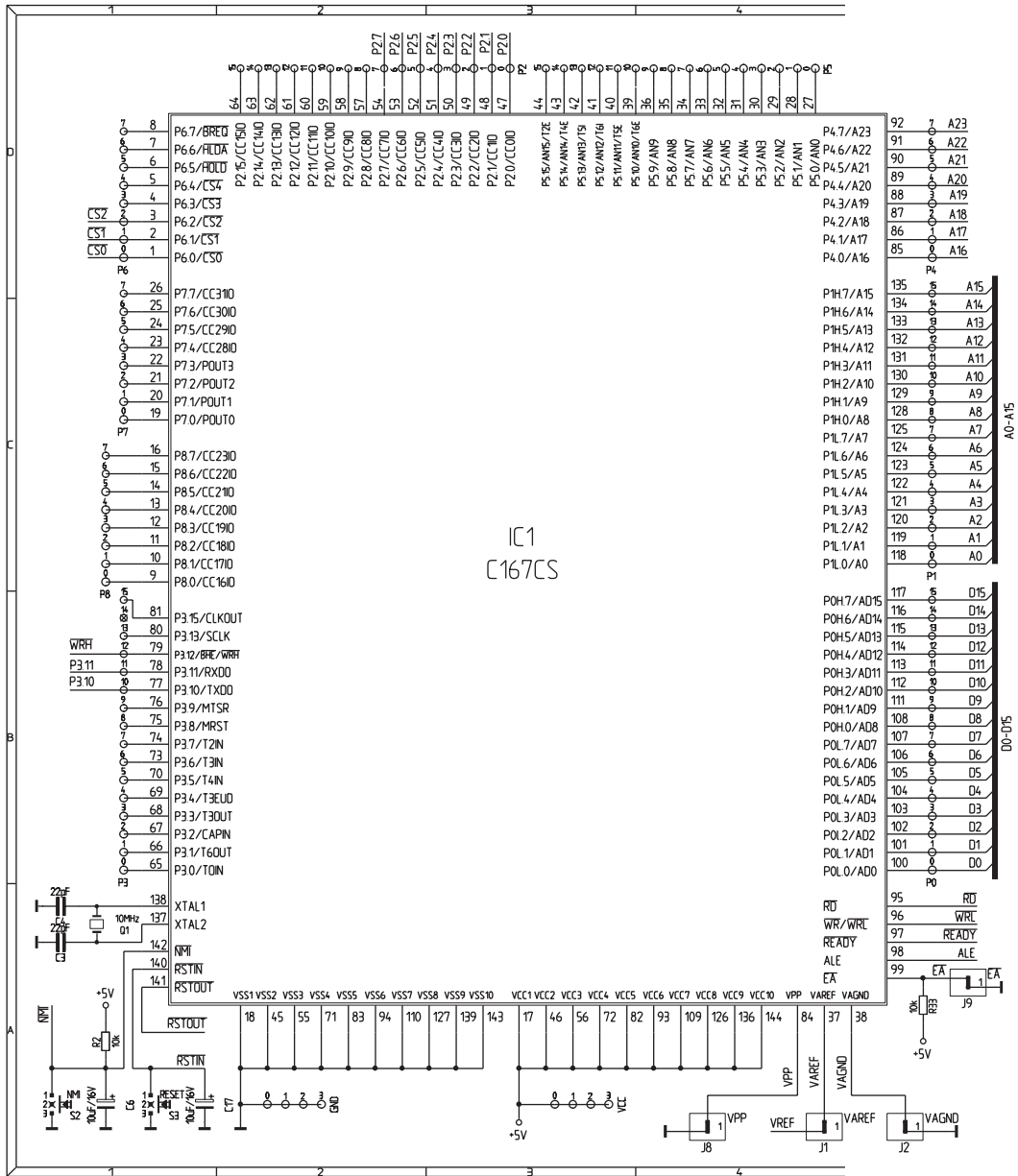

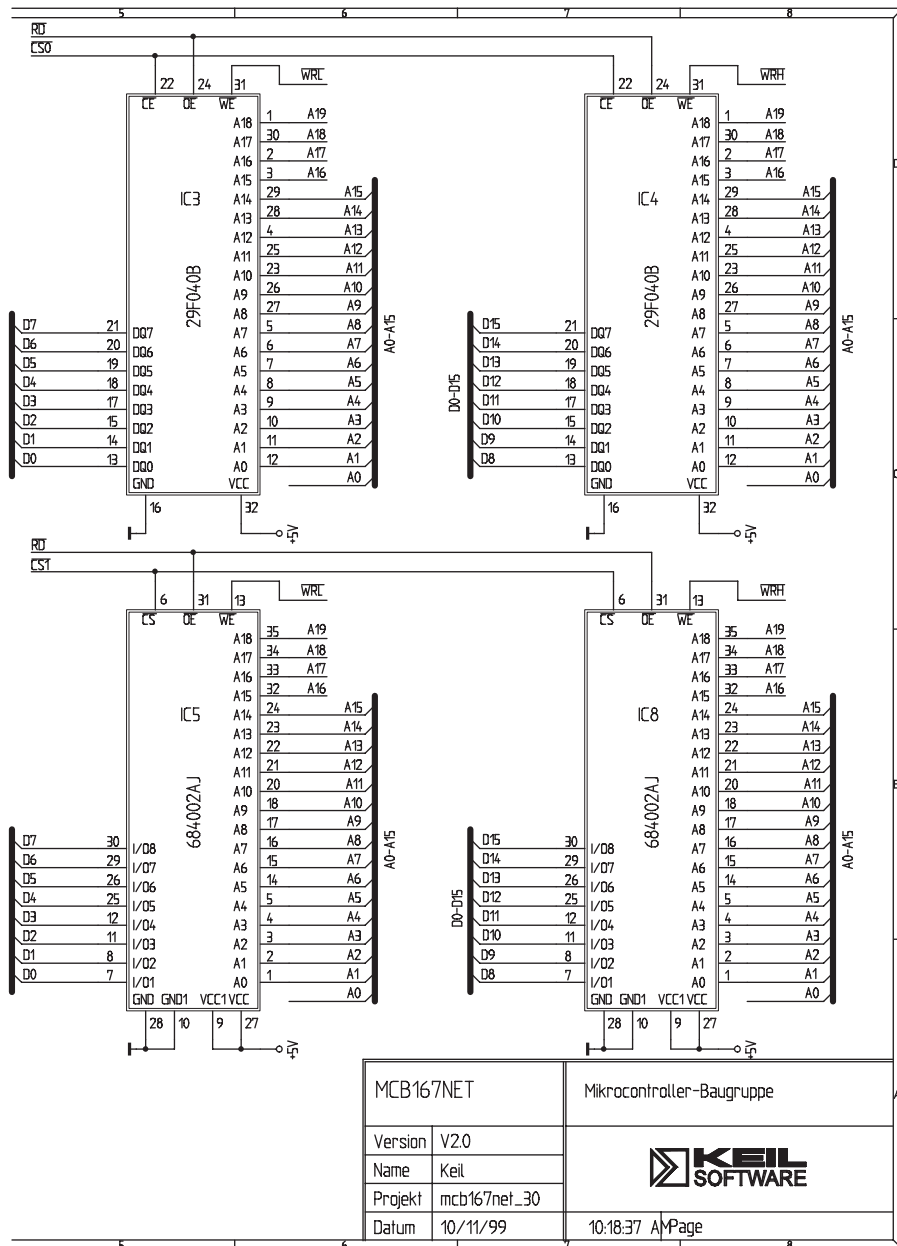

MCB167NET		Mikrocontroller-Baugruppe
Version	V2.0	
Name	Keil	
Projekt	mcb167net...30	
Datum	10/11/99	
		10:18:37 AMPage

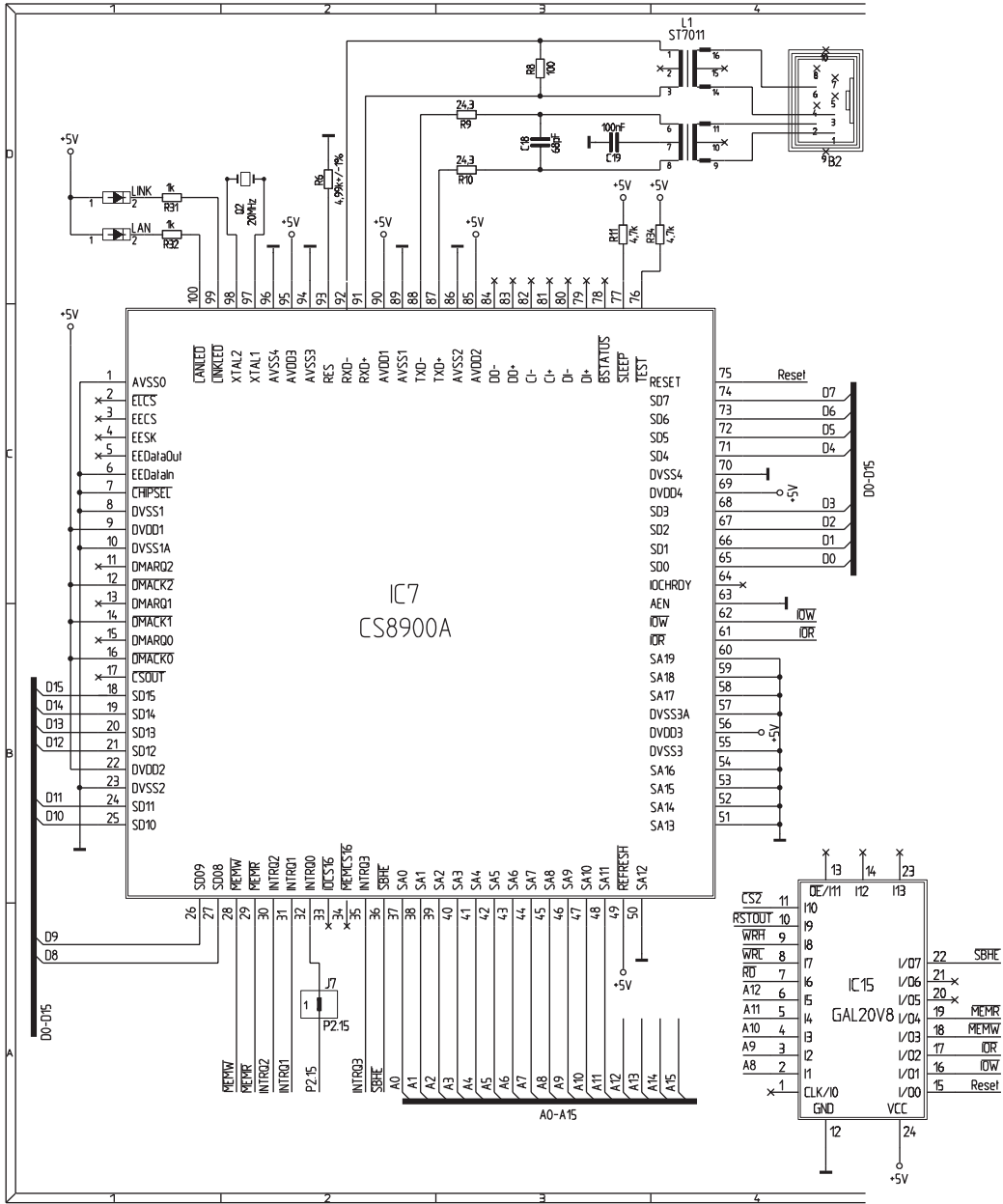

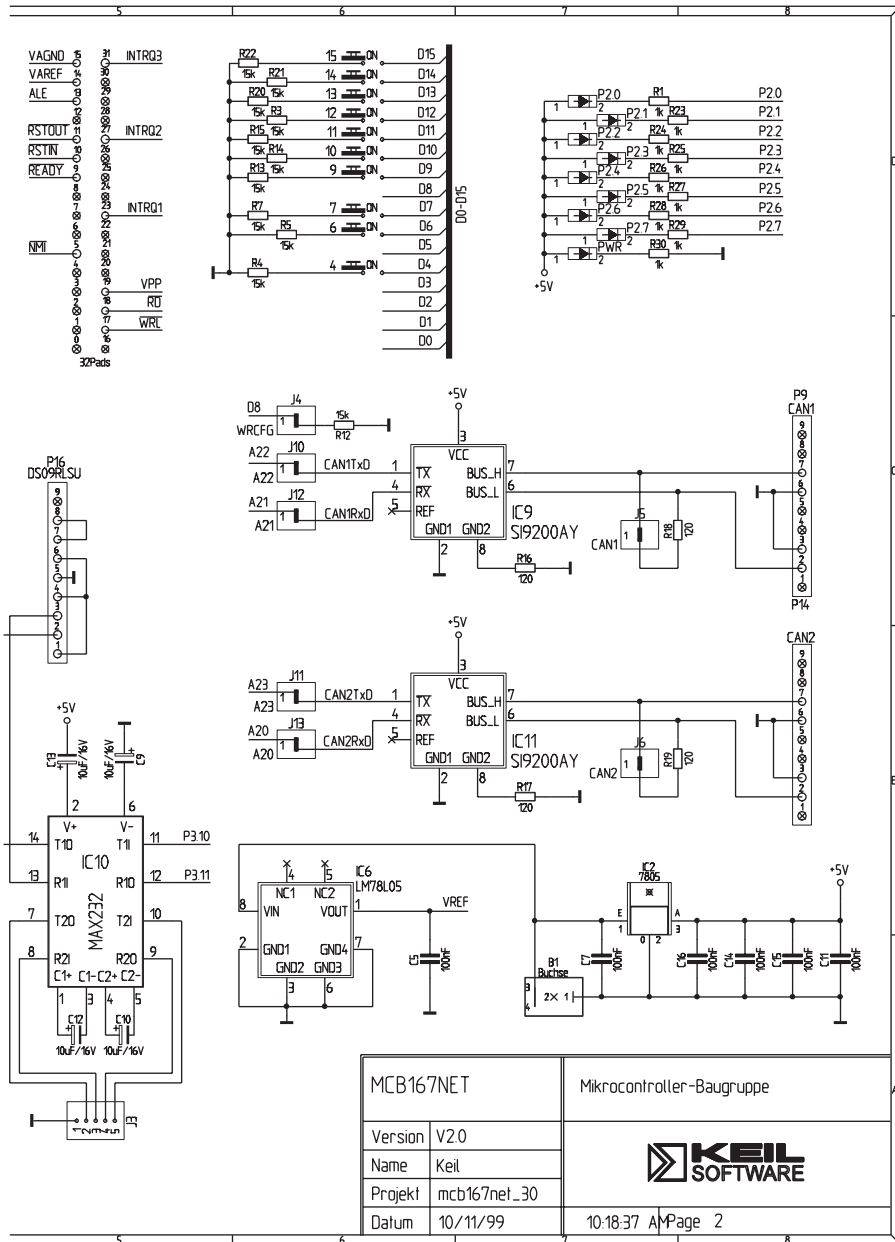

MCB167NET	Mikrocontroller-Baugruppe
Version V2.0	
Name Keil	
Projekti mcb167net_30	
Datum 10/11/99	

Printed Board Assembly

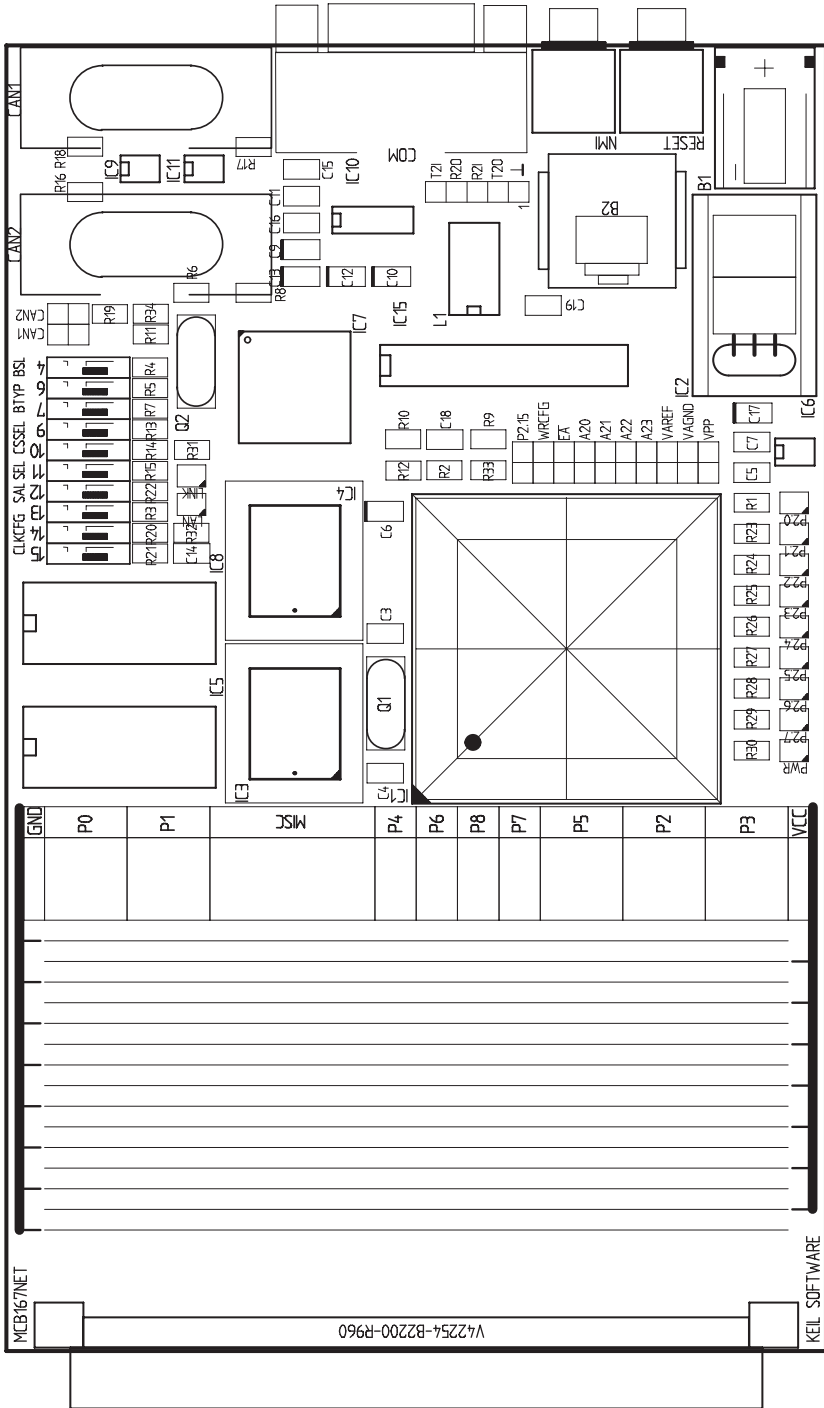

Technical Data

Supply Voltage:	8V-12V DC
Supply Current (typical):	400mA
XTAL Frequency:	10 MHz (Allows 10MHz-50MHz on-chip clock)
Memory:	1 Mbyte high-speed RAM 1 Mbyte off-chip Flash ROM (Optional)
CPU:	Infineon C167CR or C167CS ST Microelectronics ST10-167 (Optional) ST Microelectronics ST10-168 (Optional)
Peripherals:	1 × RS232 Interface, 2 × CAN Interfaces, 1 × Ethernet Controller

Pin-Out of Port Signals

The following illustrations show the pin-out for port signals located in the MCB167-NET prototyping area.

P0, P1, P2, P3, and P5 Pin-Out

● PX.12	● PX.13	● PX.14	● PX.15	P0 P1 P2 P3 P5
● PX.8	● PX.9	● PX.10	● PX.11	
● PX.4	● PX.5	● PX.6	● PX.7	
● PX.0	● PX.1	● PX.2	● PX.3	

Pin-Out for P0, P1, P2, P3, and P5 signals

P4, P6, P7, and P8 Pin-Out

● PX.4	● PX.5	● PX.6	● PX.7	P4 P6 P7 P8
● PX.0	● PX.1	● PX.2	● PX.3	

Pin-Out for P4, P6, P7, and P8 signals

MISC Pin-Out

●	●	●	● INTRQ3	MISC
●	●	●	● INTRQ2	
●	● EA/	●	● INTRQ1	
●	● WRL/	● RD/	● VPP	
●	● ALE	● VAREF	● VAGND	
●	● READY/	● RSTIN/	● RSTOUT/	
●	● NMI/	●	●	
●	●	●	●	

Pin-Out for control signals (MISC)

Chapter 4. Programming

Writing programs for the MCB167-NET is relatively simple. The process is:

1. Write a program using the μ Vision2 IDE and C166 C Compiler.
2. Start the μ Vision2 Debugger.
3. Download the program to the MCB167-NET board using the Debugger and Monitor-166.
4. Test and debug the program using the μ Vision2 Debugger and Monitor-166.

The MCB167-NET board comes with a Keil Development Tools CD-ROM that contains an Evaluation Version of the Keil C166 development tools. If you are not already using the Keil tools, you may install the evaluation version from the CD-ROM.

The following sections take you step-by-step through the process using the Keil development tools with the MCB167-NET.

Writing Programs for the MCB167-NET Boards

The following steps show you how to use μ Vision2 to create, compile, download, and run a program on the MCB167-NET board.

NOTE

*You can find more information in the **Getting Started and Creating Applications User's Guide** (C:\KEIL\C166\HLP\GS166.PDF). Refer to **Chapter 4. Creating Applications** and **Chapter 5. Testing Programs**.*



1. **Start the μ Vision2 IDE and create a new project file.**
 - Select New Project from the Project menu.
 - Select a microcontroller from the device database. The MCB167-NET board comes with the Infineon C167CR, so you should select that device. However, you may use other C167 or ST10-167/168/169 devices with the MCB167-NET hardware. Just select the device that is actually installed on the board.

2. Create a source file and add this source file to the project.

Do this in the **Project-Target, Groups, Files...** dialog or right click on a **Source Group** in the Project Window and select **Add Files to Group**.

3. Add and configure the startup code for the device.

C:\KEIL\C166\EXAMPLES\BOARDS\KEIL MCB167 NET\BLINKY\START167.A66 is pre-configured for the MCB167-NET board. You may wish to copy it to your project folder.



4. Set the tool options for MCB167-NET hardware.

- **Project-Options for Target** opens the μ Vision2 **Options for Target-Target** dialog.
- When you use Monitor-166, the complete target application is stored in RAM (so you can download the program and set breakpoints). Therefore, the 1 MByte RAM space on the MCB167-NET must be split into a ROM section for program code and a RAM section for data. One possible target configuration is shown on the right.
- On the **Options-L166 Misc** dialog, you must reserve the memory used by Monitor-166. Enter the memory that is reserved (8h-0Bh, 0ACh-0Afh) in **Reserve** input box. The required address ranges for pre-configured Monitors may be found under **Options-Debug-Settings-Description**.

Options for Target *Keil MCB167 NET*

Target | Output | Listing | C166 | A166 | L166 Locate | L166 Misc | Debug

Infineon C167CR-LM

Clock (MHz): 20.0

Memory Model: Small: 'near' functions and data Use C

Operating System: None

Data Threshold: near 6

Near Memory

16 KB RAM 16 KB ROM

External Memory

		Start	Size	
#1:	ROM	0x0	0x80000	#4: F
#2:	RAM	0x80000	0x7EA00	#5: F
#3:	RAM			#6: F

OK Cancel

Options for Target *Keil MCB167 NET*

Target | Output | Listing | C166 | A166 | L166 Locate | L166 Misc | Debug

Warnings

Level 2 Disable Warning Numbers:

use linker control file: Create... Browse...

Create Relocatable Output File (LINKONLY) Interrupt

Assign:

RegBank:

Reserve: 8H-0BH, 0ACH-0AFH

Misc Controls:

Linker Control String: TO "blinky" RESERVE (8H-0BH, 0ACH-0AFH) CLASSES (ICODE (0x0-0xDFFF), NCODE (0x10000-0x1FFFF))

OK Cancel

- To debug using Monitor-166, select **Use Keil Monitor-166 Driver** on the **Options-Debug** dialog. Select **Load Application at Startup** and **Go till main()** to automatically load and start your application when you start the debugger.

Then use the button **Settings** to open the configuration dialog for Monitor-166.

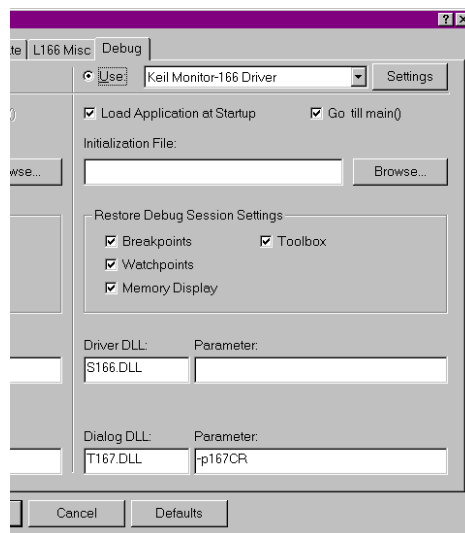

- Under Monitor Configuration select Keil MCB167 NET, select the COM Port, and select the baudrate. A good choice for the baudrate is 57600.

Power up the MCB167 NET board and connect the serial interface to the PC.

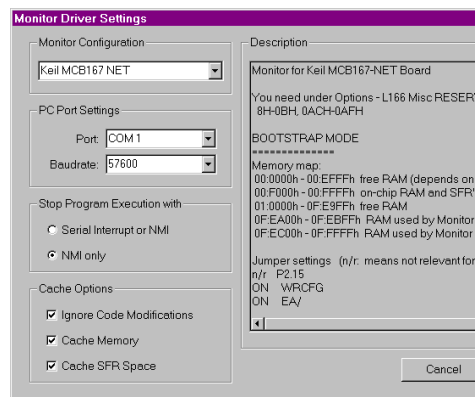

5. Build the project.

μ Vision2 should translate all your source files and link the project.



6. Start the μ Vision2 Debugger.

The debugger connects to the MCB167-NET board (via the serial port), downloads the monitor, and then downloads the application program. If there is a communication problem, a dialog box opens that displays instructions and options.



7. Run the program.

Now, you may single step through your code and use other debugger features. You will find more information on the debugger features that are available in the *Getting Started and Creating Applications User's Guide* (C:\KEIL\C166\HLP\GS166.PDF) in *Chapter 5. Testing Programs*.

BLINKY Example Program

The following simple program, **BLINKY**, is an exercise you may use to test the MCB167-NET and verify that you can use the Keil tools to generate a working program.

BLINKY blinks the LEDs on the MCB167-NET Evaluation Board. The complete source listing for the program is shown below:

```

/* BLINKY.C - LED Blinker for the Keil MCB167-NET Board */

#include <reg167.h>
#include <stdio.h>
#include <intrins.h>

void wait (void) {
    _nop_();
    _nop_();
    _nop_();
    _nop_();
    _nop_();
}

void main (void) {
    unsigned int i;
    unsigned int j;

    DP2 = 0x00FF;
    ODP2 = 0x0000;

    while (1) {
        for (j=0x0001; j != 0x0100; j<=&=1){
            P2 = ~j & 0x00FF;
            for (i = 0; i < 50000; i++) {
                wait ();
            }

            for (j=0x0080; j != 0; j>=&=1){
                P2 = ~j & 0x00FF;
                for (i = 0; i < 50000; i++) {
                    wait ();
                }
            }
        }
    }
}

```

You may build the **BLINKY** example program using the μ Vision2 project file C:\KEIL\C166\EXAMPLES\BOARDS\KEIL MCB167 NET\BLINKY\BLINKY.UV2. Once you load this project file you may create and test the application as described under “Writing Programs for the MCB167-NET” on page 25. When you run this program, the LED’s on the MCB167-NET board should blink.

Other Example Programs

The Keil C166 / μ Vision2 development tools contain several example programs that are configured for the MCB167-NET board. The sample programs may be found in the C:\KEIL\C166\EXAMPLES\ folder. Each is stored in a separate folder along with project files that help you quickly build and evaluate each sample program.

Each project has a target named **MCB167-NET** which may be selected using the build toolbar as shown on the right.



The following table lists the sample programs for the MCB167-NET board and their folder names. You may find more information about the **HELLO** and **MEASURE** examples in the *Getting Started and Creating Applications User's Guide* (C:\KEIL\C166\HLP\GS166.PDF) in *Chapter 7. Sample Programs*.

Example Program	Description
Boards/Keil MCB167 Net/Blinky	This program blinks the LEDs on the MCB167 NET board. It may be used to check that Monitor-166 and the MCB167-NET board both work correctly.
Boards/Keil MCB167 Net/Ethernet	This program checks the Ethernet controller and transmits a string via Ethernet. The string may be verified using a protocol analyzer.
Hello	This is the Hello World program. Try this program first when you begin using μ Vision2. It prints "Hello World" on the serial interface and helps you confirm that the development tools work correctly.
Measure	This program is a data acquisition system that collects analog and digital signals.

Application Notes

Keil Software provides numerous Application Notes that discuss solutions to special problems. These are available on the Keil web site at:

<http://www.keil.com/appnotes>

Look there for MCB167-NET Application Notes like: CAN Programming and Ethernet Programming.

Index

1

167 microcontroller 14

7

7805 13

78L05 13

A

A/D reference 13

A/D voltage references 12

A20 jumper 12

A21 jumper 12

A22 jumper 12

A23 jumper 12

Address lines 9

Application notes 29

ARS Software 5

B

BHE/ line 11

BLINKY example program 28

Block diagram 13

Board illustration 8

Boot strap loader 10

BSL DIP switch 10

BTYP DIP switch 10

Bus type 10

C

CAN bus drivers 12

CAN drivers 14

CAN interface 9

CAN termination 11

CAN1 bus driver 12

CAN1 jumper 11

CAN2 bus driver 12

CAN2 jumper 11

Chip select 10

Chip selects 14,15

Circuit description 13

CLKCFG DIP switch 9

Clock speed 9

CMX Company 5

Configuration 14

Configuration jumpers 11

Configuring the MCB167-NET 8

Contents of MCB167-NET kit 6

CS/ lines 10

CS0/ 14

CS1/ 14

CS2/ 15

CS8900A 29

CSSEL DIP switch 10

D

Decode logic 15

DIP switch

BSL 10

BTYP 10

CLKCFG 9

CSSEL 10

Default settings 8

SALSEL 9

SW1 8

DIP switches 8,9

E

EA/ jumper 11

EA/ line 11

Ethernet controller 29

Ethernet interface 15

Ethernet interrupt 11

EX7IN line 11

Example program

BLINKY 28

Example programs 29

External bus type 10

F

Flash programming voltage 12

Frequency 9

H

Hardware	13
Hardware requirements	7

I

Infineon 167	14
Introduction	5

J

Jumper	
A20	12
A21	12
A22	12
A23	12
CAN1	11
CAN2	11
Configuration	11
EA/	11
P2.15	11
VAGND	12
VAREF	12
VPP	12
WRCFG	11
Jumper settings	8

K

Kit contents	6
--------------	---

M

MAX232	15
MCB167-NET configuration	8
MCB167-NET illustration	8
Memory device	14

O

Oscillator frequency	9
----------------------	---

P

P2.15 jumper	11
PAL equations	17
Port signals	23
Power supply circuitry	13
Printed board assembly	22

Programming	25
Prototyping area	16
Push buttons	15

Q

Quick start	6
-------------	---

R

Reference voltages	12
Reset	14

S

SALSEL DIP switch	9
Schematics	18
Serial port	15
Setup	7
Software requirements	7
ST10 microcontroller	14
ST10-167	14
ST10-168	14
Status LEDs	15

T

Technical data	23
Termination resistors	11

U

UART	15
US Software	5
Using the board	7

V

VAGND jumper	12
VAREF jumper	12
Voltage regulator	13
Voltage references	12
VPP jumper	12

W

Watchdog timer	12
WR/ line	11
WRCFG jumper	11
WRH/ line	11

Writing programs

25

WRL/ line

11