



W78E65

8-BIT MICROCONTROLLER

GENERAL DESCRIPTION

The W78E65 is an 8-bit microcontroller which has an in-system programmable Flash EPROM for firmware updating. The instruction set of the W78E65 is fully compatible with the standard 8052. The W78E65 contains a 64K bytes of main ROM and a 4K bytes of auxiliary ROM which allows the contents of the 64KB main ROM to be updated by the loader program located at the 4KB auxiliary ROM; 256+1K bytes of on-chip RAM; four 8-bit bi-directional and bit-addressable I/O ports; an additional 4-bit port P4; three 16-bit timer/counters; a serial port. These peripherals are supported by a eight sources two-level interrupt capability. To facilitate programming and verification, the ROM inside the W78E65 allows the program memory to be programmed and read electronically. Once the code is confirmed, the user can protect the code for security.

The W78E65 microcontroller has two power reduction modes, idle mode and power-down mode, both of which are software selectable. The idle mode turns off the processor clock but allows for continued peripheral operation. The power-down mode stops the crystal oscillator for minimum power consumption. The external clock can be stopped at any time and in any state without affecting the processor.

FEATURES

- Fully static design 8-bit CMOS microcontroller
- 64K bytes of in-system programmable Flash EPROM for Application Program (APROM)
- 4K bytes of auxiliary ROM for Loader Program (LDROM)
- 256+1K bytes of on-chip RAM. (including 1K bytes of AUX-RAM, software selectable)
- 64K bytes program memory address space and 64K bytes data memory address space
- ALE off software selectable.
- Four 8-bit bi-directional ports
- One 4-bit multipurpose programmable port (I/O, interrupt, Chip select function)
- Three 16-bit timer/counters
- One full duplex serial port
- Watchdog timer
- P1.0 T2 programmable clock out
- Direct LED drive outputs for P4.4 ~ P4.7.
- Eight-sources, two-level interrupt capability
- Built-in power management
- Code protection
- Packaged in
 - DIP 40: W78E65-40
 - PLCC 44: W78E65P-40
 - QFP 44: W78E65F-40



PIN CONFIGURATIONS

40-Pin DIP (W78E65)

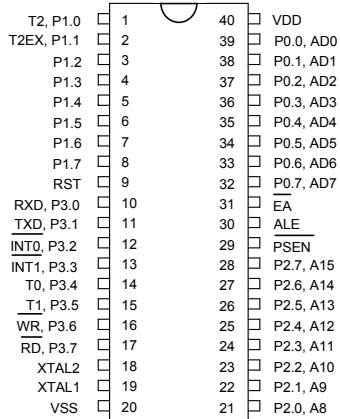

44-Pin PLCC (W78E65P)

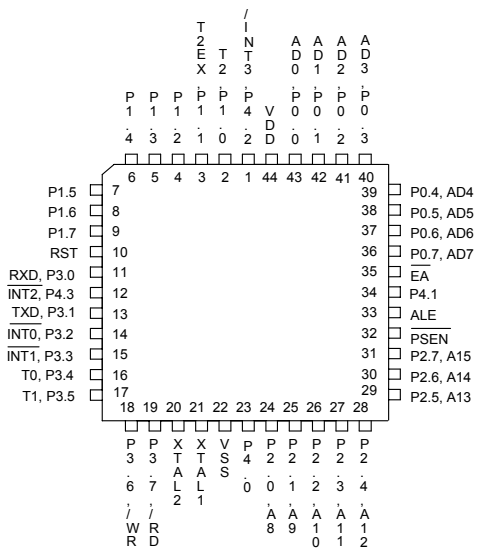

44-Pin QFP (W78E65F)

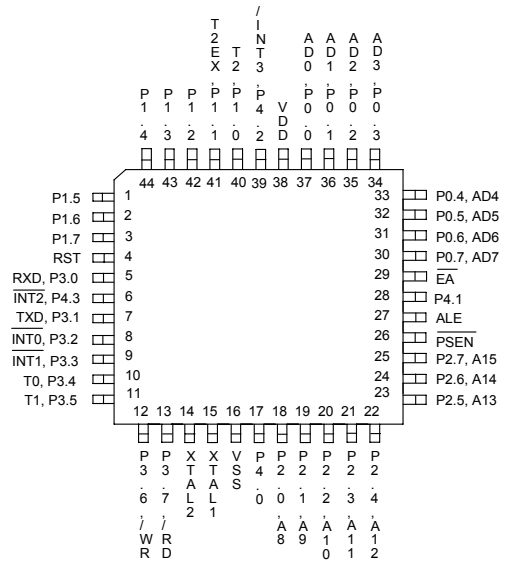



PIN DESCRIPTION

SYMBOL	TYPE	DESCRIPTIONS
\overline{EA}	I	EXTERNAL ACCESS ENABLE: This pin forces the processor to execute the external ROM. The ROM address and data will not be presented on the bus if the \overline{EA} pin is high.
\overline{PSEN}	O H	PROGRAM STORE ENABLE: \overline{PSEN} enables the external ROM data in the Port 0 address/data bus. When internal ROM access is performed, no \overline{PSEN} strobe signal outputs originate from this pin.
ALE	O H	ADDRESS LATCH ENABLE: ALE is used to enable the address latch that separates the address from the data on Port 0. ALE runs at 1/6th of the oscillator frequency.
RST	I L	RESET: A high on this pin for two machine cycles while the oscillator is running resets the device.
XTAL1	I	CRYSTAL 1: This is the crystal oscillator input. This pin may be driven by an external clock.
XTAL2	O	CRYSTAL 2: This is the crystal oscillator output. It is the inversion of XTAL1.
Vss	I	GROUND: ground potential.
VDD	I	POWER SUPPLY: Supply voltage for operation.
P0.0–P0.7	I/O D	PORT 0: Function is the same as that of standard 8052.
P1.0–P1.7	I/O H	PORT 1: Function is the same as that of standard 8052.
P2.0–P2.7	I/O H	PORT 2: Port 2 is a bi-directional I/O port with internal pull-ups. This port also provides the upper address bits for accesses to external memory.
P3.0–P3.7	I/O H	PORT 3: Function is the same as that of the standard 8052.
P4.0–P4.7	I/O H	PORT 4: A bi-directional I/O. See details below.

* Note: **TYPE** I: input, O: output, I/O: bi-directional, H: pull-high, L: pull-low, D: open drain



BLOCK DIAGRAM

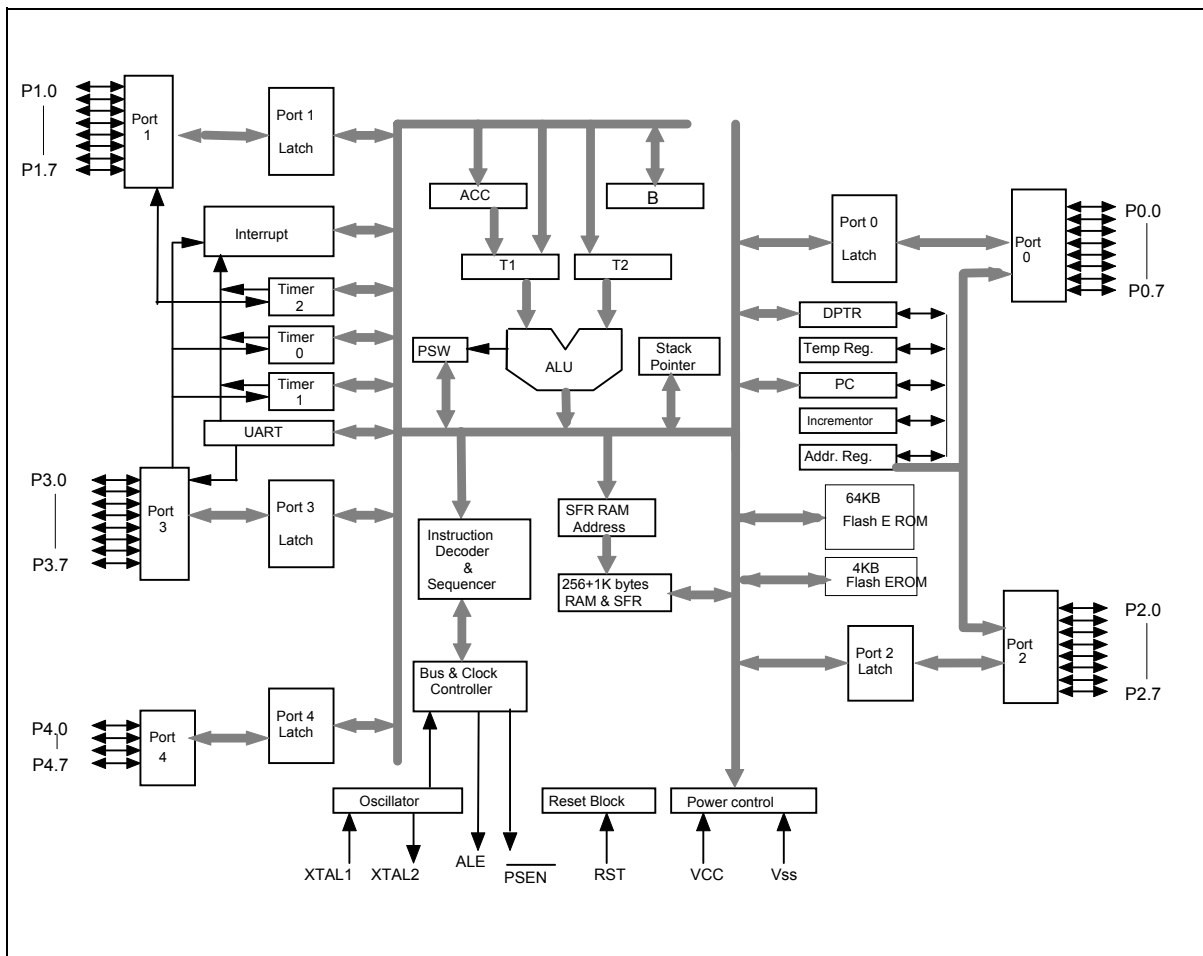

FUNCTIONAL DESCRIPTION

The W78E65 architecture consists of a core controller surrounded by various registers, four general purpose I/O ports, one special purpose programmable 4-bits I/O port, 256+1K bytes of RAM, three timer/counters, a serial port. The processor supports 111 different opcodes and references both a 64K program address space and a 64K data storage space.

RAM

The internal data RAM in the W78E65 is 256+1K bytes. It is divided into two banks: 256 bytes of scratchpad RAM and 1K bytes of AUX-RAM. These RAMs are addressed by different ways.

- RAM 0H–7FH can be addressed directly and indirectly as the same as in 8051. Address pointers are R0 and R1 of the selected register bank.
- RAM 80H–FFH can only be addressed indirectly as the same as in 8051. Address pointers are R0, R1 of the selected registers bank.



- AUX-RAM 0H–3FFH is addressed indirectly as the same way to access external data memory with the MOVX instruction. Address pointer are R0 and R1 of the selected register bank and DPTR register. An access to external data memory locations higher than 3FFH will be performed with the MOVX instruction in the same way as in the 8051. The AUX-RAM is enable after a reset. Setting the bit 4 in CHPCON register will enable the access to AUX-RAM. When executing from internal program memory, an access to AUX-RAM will not affect the Ports P0, P2, \overline{WR} and \overline{RD} .

Example,

```
CHPENR  REG    F6H
CHPCON  REG    BFH
XRAMAH  REG    A1H
```

```
MOV     CHPENR,#87H
MOV     CHPENR,#59H
ORL     CHPCON,#00010000B ; enable AUX-RAM
MOV     CHPENR,#00H
MOV     XRAMAH,#01H      ; internal high address
MOV     R0,#23H
MOV     A,#55H
MOVX    @R0,A            ; Write 55h data to 0123h AUX-RAM address.
MOV     XRAMAH,#02H
MOV     R1,#FFH         ; Read data from 02FFh AUX-RAM address.
MOVX    A,@R1
MOV     DPTR,#0134H
MOV     A,#78H
MOVX    @DPTR,A         ; Write 78h data to 0134h AUX-RAM address.
MOV     DPTR,#7FFFH
MOVX    A,@DPTR        ; Read data from the external 7FFFh address SRAM
```

Timers 0, 1, and 2

Timers 0, 1, and 2 each consist of two 8-bit data registers. These are called TL0 and TH0 for Timer 0, TL1 and TH1 for Timer 1, and TL2 and TH2 for Timer 2. The TCON and TMOD registers provide control functions for timers 0, 1. The T2CON register provides control functions for Timer 2. RCAP2H and RCAP2L are used as reload/capture registers for Timer 2. The operations of Timer 0 and Timer 1 are the same as in the W78C51. Timer 2 is a 16-bit timer/counter that is configured and controlled by the T2CON register. Like Timers 0 and 1, Timer 2 can operate as either an external event counter or as an internal timer, depending on the setting of bit C/T2 in T2CON. Timer 2 has three operating modes: capture, auto-reload, and baud rate generator. The clock speed at capture or auto-reload mode is the same as that of Timers 0 and 1.

Timer 2 Output

If Set T2OE(T2MOD.1) bit and clear C/T2 (T2CON.1) bit when CPU work at auto-reload mode and happen overflow, CPU will toggle P1.0 pin.



TIMER 2 Mode

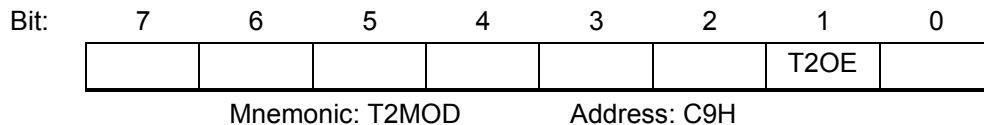

T2OE: Enable this bit to toggle P1.0 pin while Timer2 has been overflowed.

Clock

The W78E65 is designed with either a crystal oscillator or an external clock. Internally, the clock is divided by two before it is used by default. This makes the W78E65 relatively insensitive to duty cycle variations in the clock.

Crystal Oscillator

The W78E65 incorporates a built-in crystal oscillator. To make the oscillator work, a crystal must be connected across pins XTAL1 and XTAL2. In addition, a load capacitor must be connected from each pin to ground.

External Clock

An external clock should be connected to pin XTAL1. Pin XTAL2 should be left unconnected. The XTAL1 input is a CMOS-type input, as required by the crystal oscillator.



Power Management

Idle Mode

Setting the IDL bit in the PCON register enters the idle mode. In the idle mode, the internal clock to the processor is stopped. The peripherals and the interrupt logic continue to be clocked. The processor will exit idle mode when either an interrupt or a reset occurs.

Power-down Mode

When the PD bit in the PCON register is set, the processor enters the power-down mode. In this mode all of the clocks are stopped, including the oscillator. To exit from power-down mode is by a hardware reset or external interrupts $\overline{INT0}$ to $\overline{INT1}$ when enabled and set to level triggered.

Reduce EMI Emission

The W78E65 allows user to diminish the gain of on-chip oscillator amplifier by using programmer to clear the B7 bit of security register. Once B7 is set to 0, a half of gain will be decreased. Care must be taken if user attempts to diminish the gain of oscillator amplifier, reducing a half of gain may affect the external crystal operating improperly at high frequency. The value of C1 and C2 may need some adjustment while running at lower gain.

ALE OFF Function

Auxiliary Register

Bit:	7	6	5	4	3	2	1	0
	-	-	-	-	-	-	-	ALEO FF
	Mnemonic: AUXR				Address: 8EH			

ALEOFF : Set this bit to disable ALE output.

Reset

The external RESET signal is sampled at S5P2. To take effect, it must be held high for at least two machine cycles while the oscillator is running. An internal trigger circuit in the reset line is used to deglitch the reset line when the W78E65 is used with an external RC network. The reset logic also has a special glitch removal circuit that ignores glitches on the reset line. During reset, the ports are initialized to FFH, the stack pointer to 07H, PCON (with the exception of bit 4) to 00H, and all of the other SFR registers except SBUF to 00H. SBUF is not reset.

W78E65 Special Function Registers (SFRs) and Reset Values



F8									FF
F0	+B 00000000						CHPENR 00000000		F7
E8									EF
E0	+ACC 00000000								E7
D8	+P4 11111111	PWMP 00000000	PWM0 00000000	PWM1 00000000	PWMCON1 00000000	PWM2 00000000	PWM3 00000000		DF
D0	+PSW 00000000								D7
C8	+T2CON 00000000	T2MOD 00000000	RCAP2L 00000000	RCAP2H 00000000	TL2 00000000	TH2 00000000	PWMCON2 00000000	PWM4 00000000	CF
C0	+XICON 00000000		P4CONA 00000000	P4CONB 00000000	SFRAL 00000000	SFRAH 00000000	SFRFD 00000000	SFRCN 00000000	C7
B8	+IP 00000000							CHPCON 0xx00000	BF
B0	+P3 00000000				P43AL 00000000	P43AH 00000000			B7
A8	+IE 00000000				P42AL 00000000	P42AH 00000000	P4CSIN 00000000		AF
A0	+P2 11111111	XRAMAH 00000000							A7
98	+SCON 00000000	SBUF xxxxxxx							9F
90	+P1 11111111				P41AL 00000000	P41AH 00000000			97
88	+TCON 00000000	TMOD 00000000	TL0 00000000	TL1 00000000	TH0 00000000	TH1 00000000	AUXR 00000000	WDTC 00000000	8F
80	+P0 11111111	SP 0000111	DPL 00000000	DPH 00000000	P40AL 00000000	P40AH 00000000	POR 00000000	PCON 00110000	87

Notes:

Notes:

1. The SFRs marked with a plus sign(+) are both byte- and bit-addressable.
2. The text of SFR with bold type characters are extension function registers.

Port 4

Port 4, address D8H, is a 8-bit multipurpose programmable I/O port. Each bit can be configured individually by software. The Port 4 has four different operation modes.

Mode 0: P4.0–P4.3 is a bi-directional I/O port which is same as port 1. P4.2 and P4.3 also serve as external interrupt $\overline{\text{PSEN}}$ and $\overline{\text{INT2}}$ if enabled.

Mode 1: P4.0–P4.3 are read strobe signals that are synchronized with $\overline{\text{RD}}$ signal at specified addresses. These signals can be used as chip-select signals for external peripherals.

Mode 2: P4.0–P4.3 are write strobe signals that are synchronized with $\overline{\text{WR}}$ signal at specified addresses. These signals can be used as chip-select signals for external peripherals.



Mode 3: P4.0–P4.3 are read/write strobe signals that are synchronized with \overline{RD} or \overline{WR} signal at specified addresses. These signals can be used as chip-select signals for external peripherals.

When Port 4 is configured with the feature of chip-select signals, the chip-select signal address range depends on the contents of the SFR P4xAH, P4xAL, P4CONA and P4CONB. The registers P4xAH and P4xAL contain the 16-bit base address of P4.x. The registers P4CONA and P4CONB contain the control bits to configure the Port 4 operation mode.

The high nibble of port4(P4.4 to P4.7) can be selected to serve to the direct LED display drive outputs by setting the HDx bit is set, the corresponding pin p4.x can sink about 20mA current for driving LED display directly.

Port Options Register

Bit:	7	6	5	4	3	2	1	0
	-	-	-	HD47	HD46	HD45	HD44	P0UP
	Mnemonic: PWM2			Address: DDH				

HD47-44: Enable pins P4.4 to P4.7 individually with high drive outputs.

P0UP: Enable Port 0 weak up. The pins of Port 0 can be configured with either the open drain or standart port with internal pull-up. By the default, Port 0 is an open drain bi-directional I/O port. When the P0UP bit in the POR register is set, the pins of port 0 will perform a bi-directional I/O port with internal pull-up that is structurally the same Port2.

$\overline{INT2}$ / $\overline{INT3}$

Two additional external interrupts, $\overline{INT2}$ and $\overline{INT3}$, whose functions are similar to those of external interrupt 0 and 1 in the standard 80C52. The functions/status of these interrupts are determined/shown by the bits in the XICON (External Interrupt Control) register. The XICON register is bit-addressable but is not a standard register in the standard 80C52. Its address is at 0C0H. To set/clear bits in the XICON register, one can use the "SETB (\overline{CLR}) bit" instruction. For example, "SETB 0C2H" sets the EX2 bit of XICON.

**XICON - external interrupt control (C0H)**

PX3	EX3	IE3	IT3	PX2	EX2	IE2	IT2
-----	-----	-----	-----	-----	-----	-----	-----

PX3: External interrupt 3 priority high if set

EX3: External interrupt 3 enable if set

IE3: If IT3 = 1, IE3 is set/cleared automatically by hardware when interrupt is detected/serviced

IT3: External interrupt 3 is falling-edge/low-level triggered when this bit is set/cleared by software

PX2: External interrupt 2 priority high if set

EX2: External interrupt 2 enable if set

IE2: If IT2 = 1, IE2 is set/cleared automatically by hardware when interrupt is detected/serviced

IT2: External interrupt 2 is falling-edge/low-level triggered when this bit is set/cleared by software

Eight-source interrupt information:

INTERRUPT SOURCE	VECTOR ADDRESS	POLLING SEQUENCE WITHIN PRIORITY LEVEL	ENABLE REQUIRED SETTINGS	INTERRUPT TYPE EDGE/LEVEL
External Interrupt 0	03H	0 (highest)	IE.0	TCON.0
Timer/Counter 0	0BH	1	IE.1	-
External Interrupt 1	13H	2	IE.2	TCON.2
Timer/Counter 1	1BH	3	IE.3	-
Serial Port	23H	4	IE.4	-
Timer/Counter 2	2BH	5	IE.5	-
External Interrupt 2	33H	6	XICON.2	XICON.0
External Interrupt 3	3BH	7 (lowest)	XICON.6	XICON.3

P4CONB (C3H)

BIT	NAME	FUNCTION
7, 6	P43FUN1 P43FUN0	00: Mode 0. P4.3 is a general purpose I/O port which is the same as Port1. 01: Mode 1. P4.3 is a Read Strobe signal for chip select purpose. The address range depends on the SFR P43AH, P43AL, P43CMP1 and P43CMP0. 10: Mode 2. P4.3 is a Write Strobe signal for chip select purpose. The address range depends on the SFR P43AH, P43AL, P43CMP1 and P43CMP0. 11: Mode 3. P4.3 is a Read/Write Strobe signal for chip select purpose. The address range depends on the SFR P43AH, P43AL, P43CMP1, and P43CMP0.



P4CONB (C3H), continued

BIT	NAME	FUNCTION
5, 4	P43CMP1 P43CMP0	Chip-select signals address comparison: 00: Compare the full address (16 bits length) with the base address register P43AH, P43AL. 01: Compare the 15 high bits (A15–A1) of address bus with the base address register P43AH, P43AL. 10: Compare the 14 high bits (A15–A2) of address bus with the base address register P43AH, P43AL. 11: Compare the 8 high bits (A15–A8) of address bus with the base address register P43AH, P43AL.
3, 2	P42FUN1 P42FUN0	The P4.2 function control bits which are the similar definition as P43FUN1, P43FUN0.
1, 0	P42CMP1 P42CMP0	The P4.2 address comparator length control bits which are the similar definition as P43CMP1, P43CMP0.

P4CONA (C2H)

BIT	NAME	FUNCTION
7, 6	P41FUN1 P41FUN0	The P4.1 function control bits which are the similar definition as P43FUN1, P43FUN0.
5, 4	P41CMP1 P41CMP0	The P4.1 address comparator length control bits which are the similar definition as P43CMP1, P43CMP0.
3, 2	P40FUN1 P40FUN0	The P4.0 function control bits which are the similar definition as P43FUN1, P43FUN0.
1, 0	P40CMP1 P40CMP0	The P4.0 address comparator length control bits which are the similar definition as P43CMP1, P43CMP0.

P4CSIN (AEH)

BIT	NAME	FUNCTION
7	P43CSINV	The active polarity of P4.3 when pin P4.3 is defined as read and/or write strobe signal. = 1: P4.3 is active high when pin P4.3 is defined as read and/or write strobe signal. = 0: P4.3 is active low when pin P4.3 is defined as read and/or write strobe signal.
6	P42CSINV	The similarity definition as P43SINV.
5	P41CSINV	The similarity definition as P43SINV.
4	P40CSINV	The similarity definition as P43SINV.
3	-	Reserve
2	-	Reserve
1	-	0
0	-	0



Port 4 Base Address Registers

P40AH, P40AL:

The Base address register for comparator of P4.0. P40AH contains the high-order byte of address, P40AL contains the low-order byte of address.

P41AH, P41AL:

The Base address register for comparator of P4.1. P41AH contains the high-order byte of address, P41AL contains the low-order byte of address.

P42AH, P42AL:

The Base address register for comparator of P4.2. P42AH contains the high-order byte of address, P42AL contains the low-order byte of address.

P43AH, P43AL:

The Base address register for comparator of P4.3. P43AH contains the high-order byte of address, P43AL contains the low-order byte of address.

P4 (D8H)

BIT	NAME	FUNCTION
7	P47	I/O pin
6	P46	I/O pin.
5	P45	I/O pin.
4	P44	I/O pin.
3	P43	Port 4 Data bit which outputs to pin P4.3 at mode 0.
2	P42	Port 4 Data bit. which outputs to pin P4.2 at mode 0.
1	P41	Port 4 Data bit. which outputs to pin P4.1 at mode 0.
0	P40	Port 4 Data bit which outputs to pin P4.0 at mode 0.

Here is an example to program the P4.0 as a write strobe signal at the I/O port address 1234H–1237H and positive polarity, and P4.1–P4.3 are used as general I/O ports. P4.4 ~ P4.7 is only available for 48 pin package.

```
MOV P40AH,#12H
MOV P40AL,#34H           ; Base I/O address 1234H for P4.0
MOV P4CONA,#00001010B   ; P4.0 a write strobe signal and address line A0 and A1 are masked.
MOV P4CONB,#00H         ; P4.1–P4.3 as general I/O port which are the same as PORT1
MOV P2ECON,#10H        ; Write the P40SINV = 1 to inverse the P4.0 write strobe polarity
                        ; default is negative.
```

Then any instruction MOVX @DPTR,A (with DPTR = 1234H–1237H) will generate the positive polarity write strobe signal at pin P4.0. And the instruction MOV P4,#XX will output the bit3 to bit1 of data #XX to pin P4.3–P4.1.

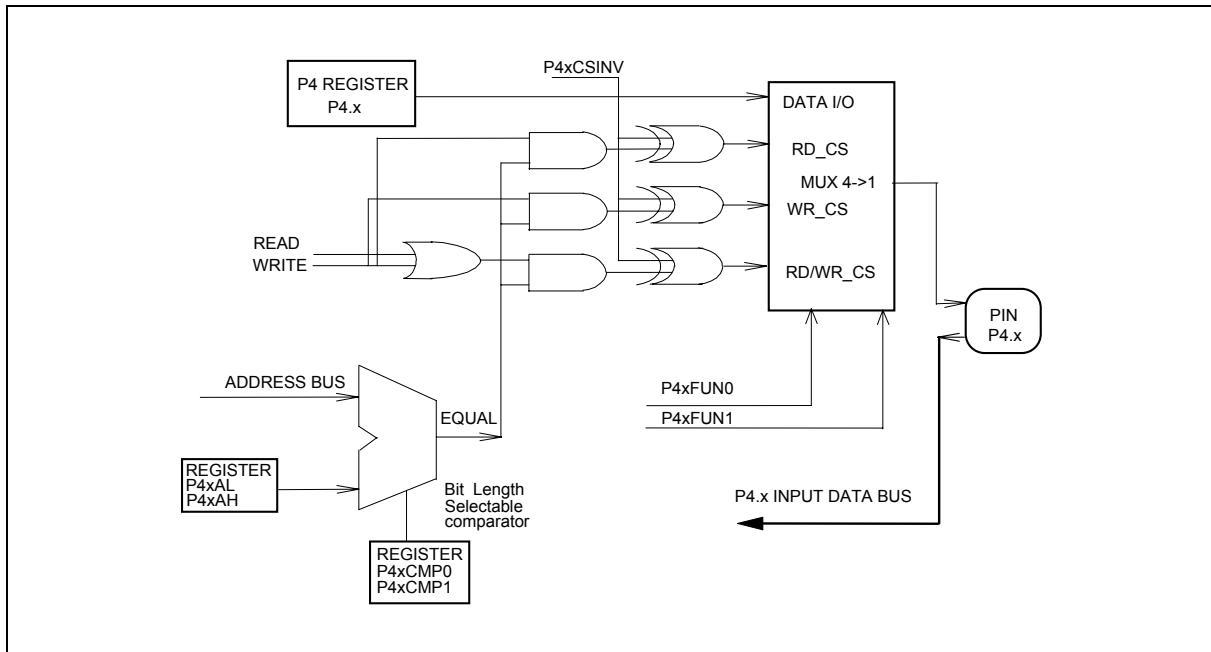

Pulse Width Modulated Outputs (PWM)

There are five pulse width modulated output channels to generate pulses of programmable length and interval. The repetition frequency is defined by an 8-bit prescaler PWMP, which supplies the clock for the counter. The prescaler and counter are common to both PWM channels. The 8-bit counter counts modular 255 (0 ~ 254). The value of the 8-bit counter is compared to the contents of five registers: PWM0, PWM1, PWM2, PWM3 and PWM4. Provided the contents of either of these registers is greater than the counter value, the corresponding PWM0, PWM1, PWM2, PWM3 or PWM4 output is set HIGH. If the contents of these registers are equal to, or less than the counter value, the output will be LOW. The pulse-width-ratio is therefore defined by the contents of the registers PWM0, PWM1, PWM2, PWM3 and PWM4. The pulse-width-ratio is in the range of 0 to 1 and may be programmed in increments of 1/255. ENPWM0, ENPWM1, ENPWM2, ENPWM3 and ENPWM4 bit will enable or disable PWM output.

Buffered PWM outputs may be used to drive DC motors. The rotation speed of the motor would be proportional to the contents of PWM0/1/2/3/4. The repetition frequency f_{pwm} , at the PWM0/1/2/3/4 output is given by:

$$f_{pwm} = \frac{f_{osc}}{2 \times (1 + PWMP) \times 255}$$

Prescaler division factor = PWM + 1

$$\text{PWMn high/low ratio of PWMn} = \frac{(\text{PWMn})}{255 - (\text{PWMn})}$$



This gives a repetition frequency range of 123 Hz to 31.4K Hz ($f_{osc} = 16\text{M Hz}$). By loading the PWM registers with either 00H or FFH, the PWM channels will output a constant HIGH or LOW level, respectively. Since the 8-bit counter counts modulo 255, it can never actually reach the value of the PWM registers when they are loaded with FFH.

When a compare register (PWM0, PWM1, PWM2, PWM3, PWM4) is loaded with a new value, the associated output updated immediately. It does not have to wait until the end of the current counter period. There is weakly pulled high on PWM output.

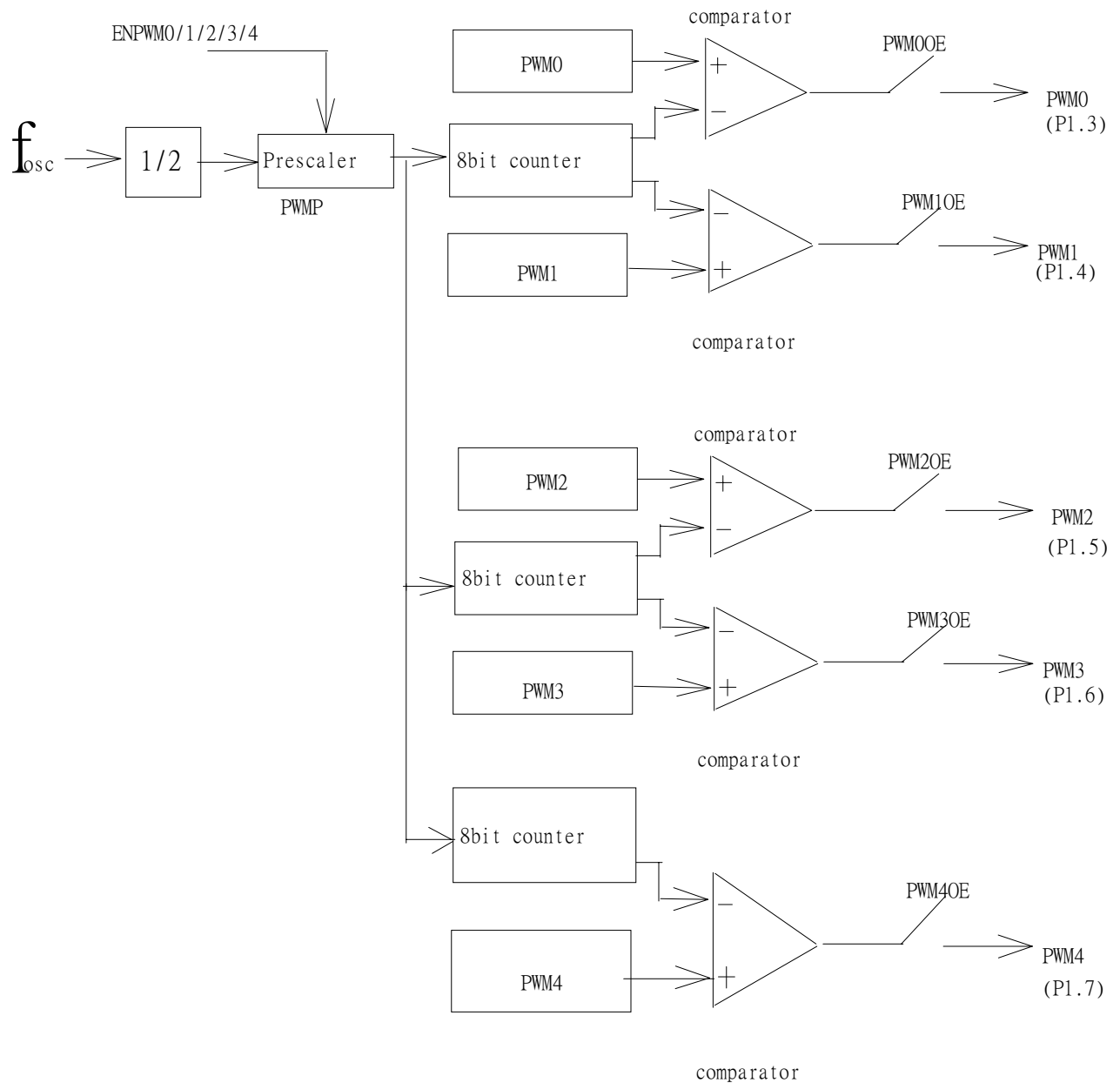

Figure 1 PWM diagram

Please refer as below code.

```

mov  pwmcon1,#00110011b  ;enable pwm3,2,1,0
mov  pwmcon2,#00000101b  ;enable pwm4
mov  pwmp,#40h           ;Fpwm=XT/(2*(1+pwmp)*255)
jb  p1.3,$
mov  pwm0,#14h           ;duty cycle high/low= pwm0/(255-pmw0)

```





```

jb  p1.4,$
mov pwm1,#18h
jb  p1.5,$
mov pwm2,#20h
jb  p1.6,$
mov pwm3,#b0h
jb  p1.7,$
mov pwm4,#40h
mov pwmcon1,#1111111b ;output enable pwm3,2,1,0
    
```

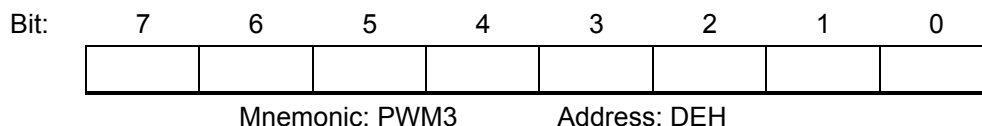
PWM3 Register

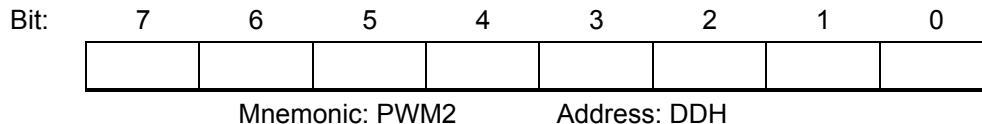

PWM2 Register



PWM CONTROL 1 Register

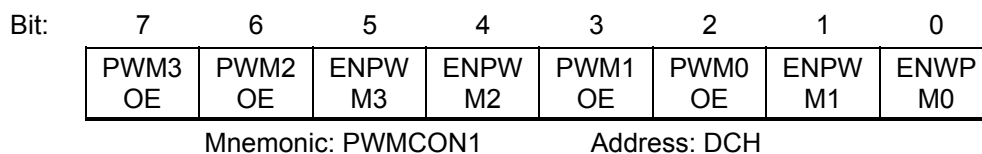

- PWM3OE: Output enable for PWM3
- PWM2OE: Output enable for PWM2
- ENPWM3: Enable PWM3
- ENPWM2: Enable PWM2
- PWM1OE: Output enable for PWM1
- PWM0OE: Output enable for PWM0
- ENPWM1: Enable PWM1
- ENPWM0: Enable PWM0

PWM1 Register

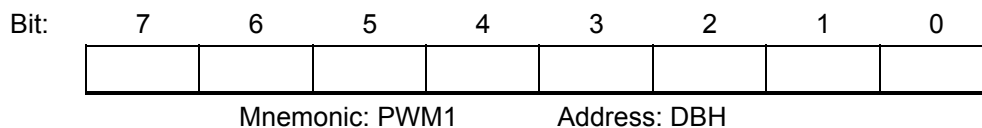

PWM0 Register

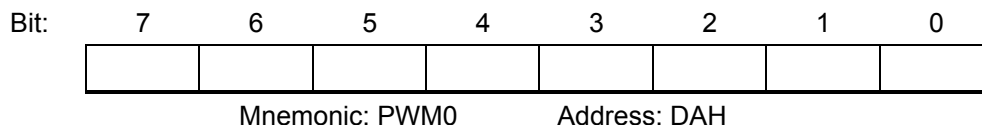

PWMP Register

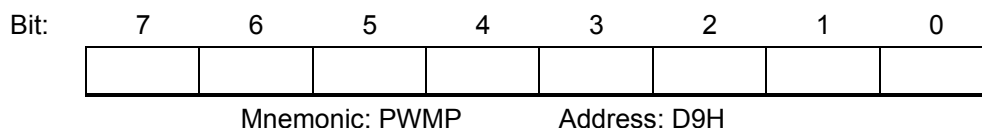

PWM4 Register

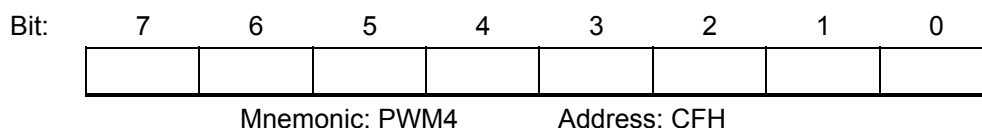

PWM CONTROL 2 Register

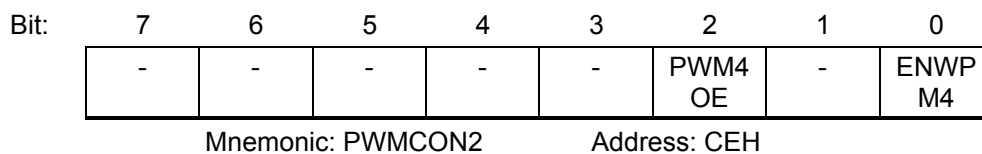

PWM4OE: Output enable for PWM4

ENPWM: Enable for PWM4

Watchdog Timer

The Watchdog timer is a free-running timer which can be programmed by the user to serve as a system monitor, a time-base generator or an event timer. It is basically a set of dividers that divide the system clock. The divider output is selectable and determines the time-out interval. When the time-out occurs, a system reset can also be caused if it is enabled. The main use of the Watchdog timer is as a system monitor. This is important in real-time control applications. In case of power glitches or electro-magnetic interference, the processor may begin to execute errant code. If this is left unchecked the entire system may crash. The watchdog time-out selection will result in different time-out values depending on the clock speed. The Watchdog timer will be disabled on reset. In general, software should restart the Watchdog timer to put it into a known state. The control bits that support the Watchdog timer are discussed below.



Watchdog Timer Control Register

Bit:	7	6	5	4	3	2	1	0
	ENW	CLRW	WIDL	-	-	PS2	PS1	PS0
	Mnemonic: WDTC				Address: 8FH			

ENW : Enable watch-dog if set.

CLRW : Clear watch-dog timer and prescaler if set. This flag will be cleared automatically

WIDL : If this bit is set, watch-dog is enabled under IDLE mode. If cleared, watch-dog is disabled under IDLE mode. Default is cleared.

PS2, PS1, PS0: Watch-dog prescaler timer select. Prescaler is selected when set PS2–0 as follows:

PS2	PS1	PS0	PRESCALER SELECT
0	0	0	2
0	0	1	4
0	1	0	8
0	1	1	16
1	0	0	32
1	0	1	64
1	1	0	128
1	1	1	256

The time-out period is obtained using the following equation:

$$\frac{1}{\text{OSC}} \times 2^{14} \times \text{PRESCALER} \times 1000 \times 12 \text{ mS}$$

Before Watchdog time-out occurs, the program must clear the 14-bit timer by writing 1 to WDTC.6 (CLRW). After 1 is written to this bit, the 14-bit timer, prescaler and this bit will be reset on the next instruction cycle. The Watchdog timer is cleared on reset.

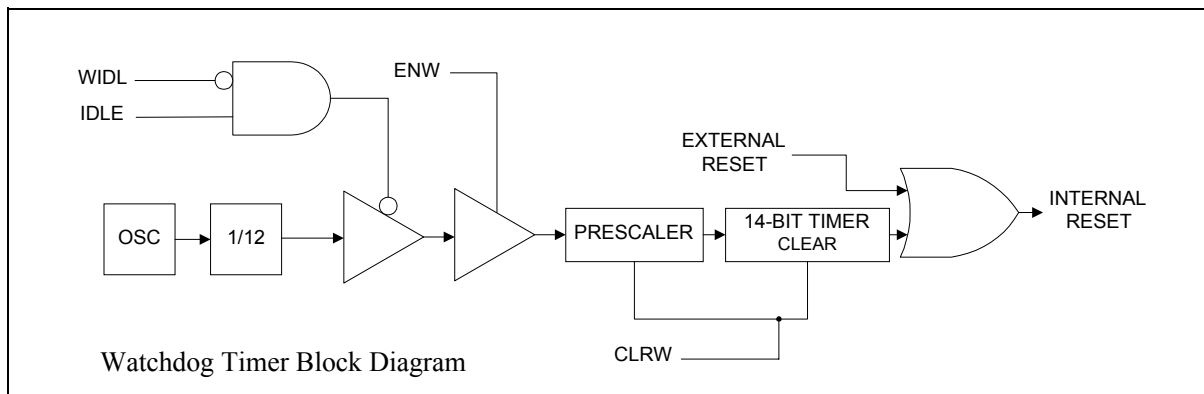

Typical Watch-Dog time-out period when OSC = 20 MHz



PS2 PS1 PS0	WATCHDOG TIME-OUT PERIOD
0 0 0	19.66 mS
0 0 1	39.32 mS
0 1 0	78.64 mS
0 1 1	157.28 mS
1 0 0	314.57 mS
1 0 1	629.14 mS
1 1 0	1.25 S
1 1 1	2.50 S

In-System Programming (ISP) Mode

The W78E65 equips one 64K byte of main ROM bank for application program (called APROM) and one 4K byte of auxiliary ROM bank for loader program (called LDRROM). In the normal operation, the microcontroller executes the code in the APROM. If the content of APROM needs to be modified, the W78E65 allows user to activate the In-System Programming (ISP) mode by setting the CHPCON register. **The CHPCON is read-only by default, software must write two specific values 87H, then 59H sequentially to the CHPENR register to enable the CHPCON write attribute. Writing CHPENR register with the values except 87H and 59H will close CHPCON register write attribute.** The W78E65 achieves all in-system programming operations including enter/exit ISP Mode, program, erase, read ... etc, during device in the idle mode. Setting the bit CHPCON.0 the device will enter in-system programming mode after a wake-up from idle mode. Because device needs proper time to complete the ISP operations before awoken from idle mode, software may use timer interrupt to control the duration for device wake-up from idle mode. To perform ISP operation for revising contents of APROM, software located at APROM setting the CHPCON register then enter idle mode, after awoken from idle mode the device executes the corresponding interrupt service routine in LDRROM. Because the device will clear the program counter while switching from APROM to LDRROM, the first execution of RETI instruction in interrupt service routine will jump to 00H at LDRROM area. The device offers a software reset for switching back to APROM while the content of APROM has been updated completely. **Setting CHPCON register bit 0, 1 and 7 to logic-1 will result a software reset to reset the CPU.** The software reset serves as a external reset. This in-system programming feature makes the job easy and efficient in which the application needs to update firmware frequently. In some applications, the in-system programming feature make it possible to easily update the system firmware without opening the chassis.



SFRAH, SFRAL: The objective address of on-chip ROM in the in-system programming mode. SFRAH contains the high-order byte of address, SFRAL contains the low-order byte of address.

SFRFD: The programming data for on-chip ROM in programming mode.

SFRCN: The control byte of on-chip ROM programming mode.

SFRCN (C7)

BIT	NAME	FUNCTION
7	-	Reserve.
6	WFWIN	On-chip ROM bank select for in-system programming. = 0: 64K bytes ROM bank is selected as destination for re-programming. = 1: 4K bytes ROM bank is selected as destination for re-programming.
5	OEN	ROM output enable.
4	CEN	ROM chip enable.
3, 2, 1, 0	CTRL[3:0]	The flash control signals

MODE	WFWIN	CTRL<3:0>	OEN	CEN	SFRAH, SFRAL	SFRFD
Erase 64KB APROM	0	0010	1	0	X	X
Program 64KB APROM	0	0001	1	0	Address in	Data in
Read 64KB APROM	0	0000	0	0	Address in	Data out
Erase 4KB LDROM	1	0010	1	0	X	X
Program 4KB LDROM	1	0001	1	0	Address in	Data in
Read 4KB LDROM	1	0000	0	0	Address in	Data out



In-System Programming Control Register (CHPCON)

CHPCON (BFH)

BIT	NAME	FUNCTION
7	SWRESET	When this bit is set to 1, and both FBOOTSL and FPROGEN are set to 1. It will enforce microcontroller reset to initial condition just like power on reset.
6	-	Reserve.
5	LD/AP	This bit is read only. 1: CPU is running LDROM program. 0: CPU is running APROM program.
4	ENAUSTRAM	1: Enable on-chip AUX-RAM. 0: Disable the on-chip AUX-RAM
3	1	Must be 1
2	-	Reserve.
1	FBOOTSL	When this bit is set to 1, and both SWRESET and FPROGEN are set to 1. It will enforce microcontroller reset to initial condition just like power on reset.
0	FPROGEN	When this bit is set to 1, and both SWRESET and FBOOTSL are set to 1. It will enforce microcontroller reset to initial condition just like power on reset.

This register is protected by CHPENR register. Please write as below procedures while you would like to write CHPCON register.

```
Mov CHPENR,#87h
```

```
Mov CHPENR,#59h
```

```
Anl CHPCON,#EFh ;Disable AUX-RAM
```

```
Mov CHPENR,#0h
```

F04KBOOT Mode (Boot From LDROM)

By default, the W78E65 boots from APROM program after a power on reset. On some occasions, user can force the W78E65 to boot from the LDROM program via following settings. The possible situation that you need to enter F04KBOOT mode when the APROM program can not run properly and device can not jump back to LDROM to execute in-system programming function. Then you can use this F04KBOOT mode to force the W78E65 jumps to LDROM and executes in-system programming procedure. When you design your system, you may reserve the pins P2.6, P2.7 to switches or jumpers. For example in a CD-ROM system, you can connect the P2.6 and P2.7 to PLAY and EJECT buttons on the panel. When the APROM program fails to execute the normal application program. User can press both two buttons at the same time and then turn on the power of the personal computer to force the W78E65 to enter the F04KBOOT mode. After power on of personal computer, you can release both buttons and finish the in-system programming procedure to update the APROM code. In application system design, user must take care of the P2, P3, ALE, EA and PSEN pin value at reset to prevent from accidentally activating the programming mode or F04KBOOT mode.



F04KBOOT MODE

P4.3	P2.7	P2.6	MODE
X	L	L	F04KBOOT
L	X	X	F04KBOOT

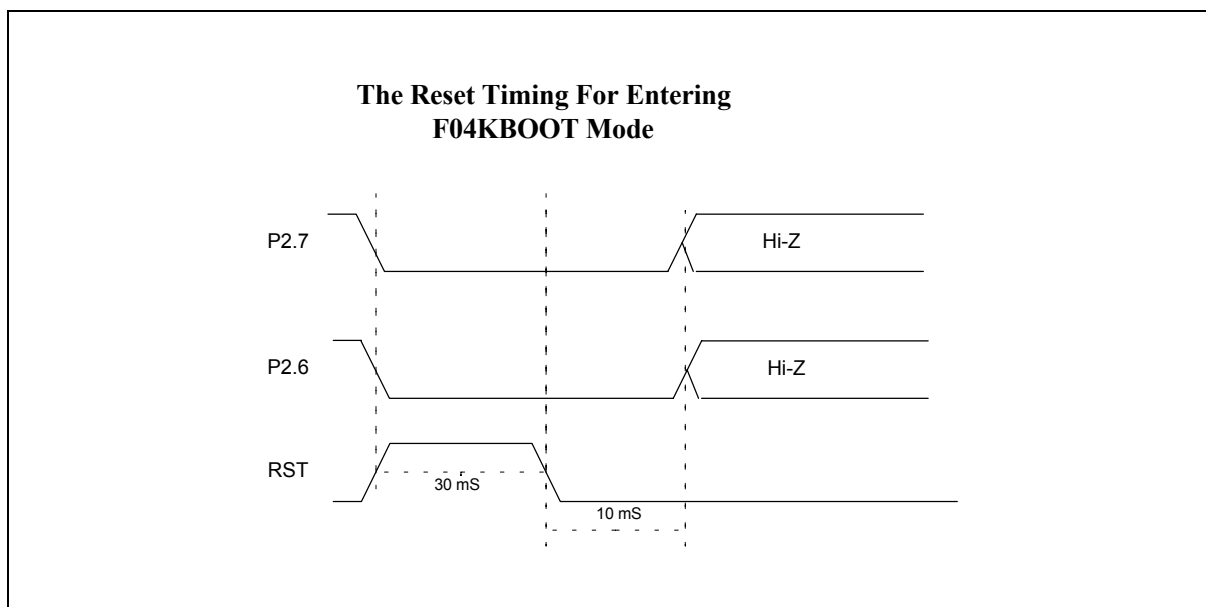

The Algorithm of In-System Programming

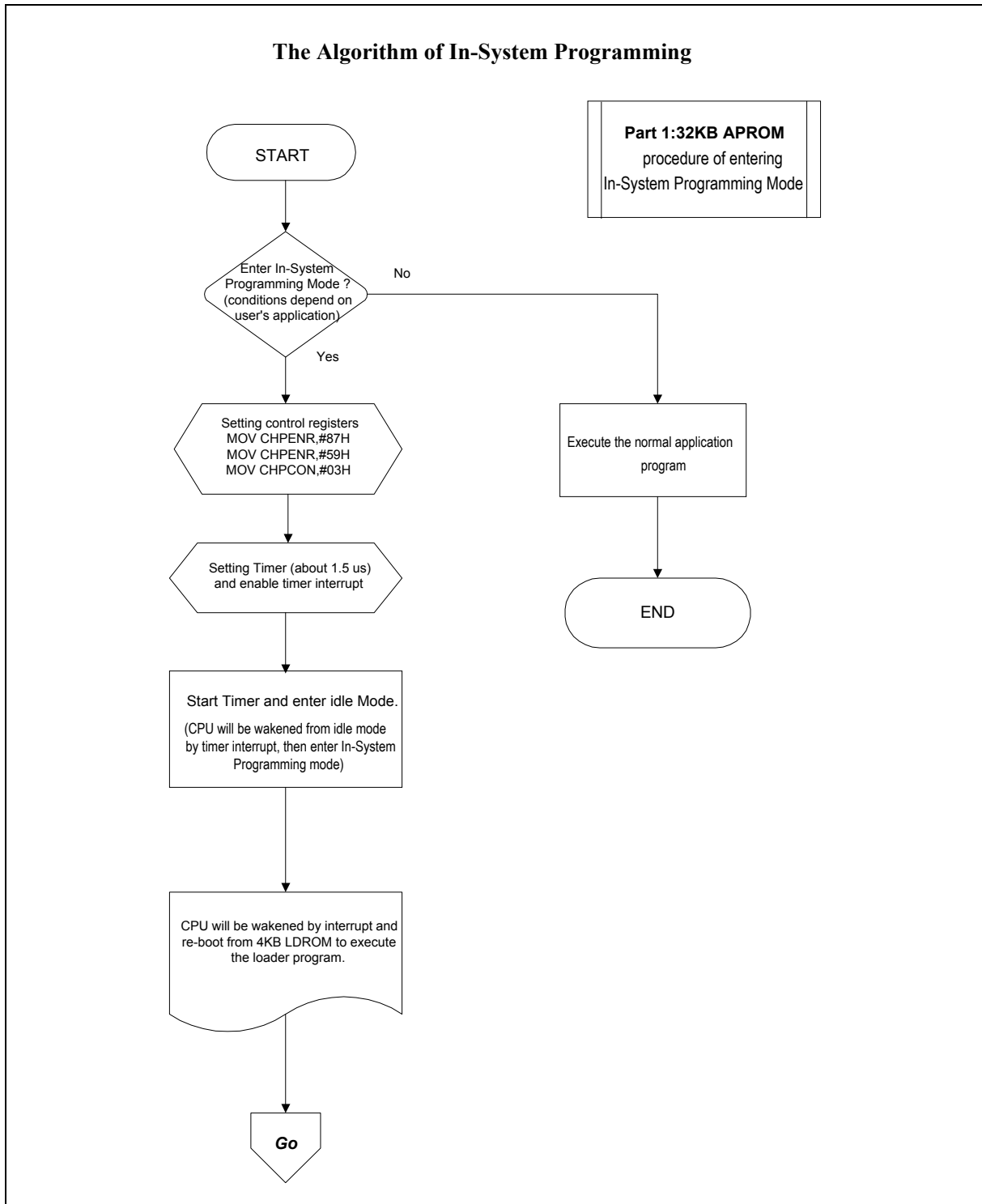

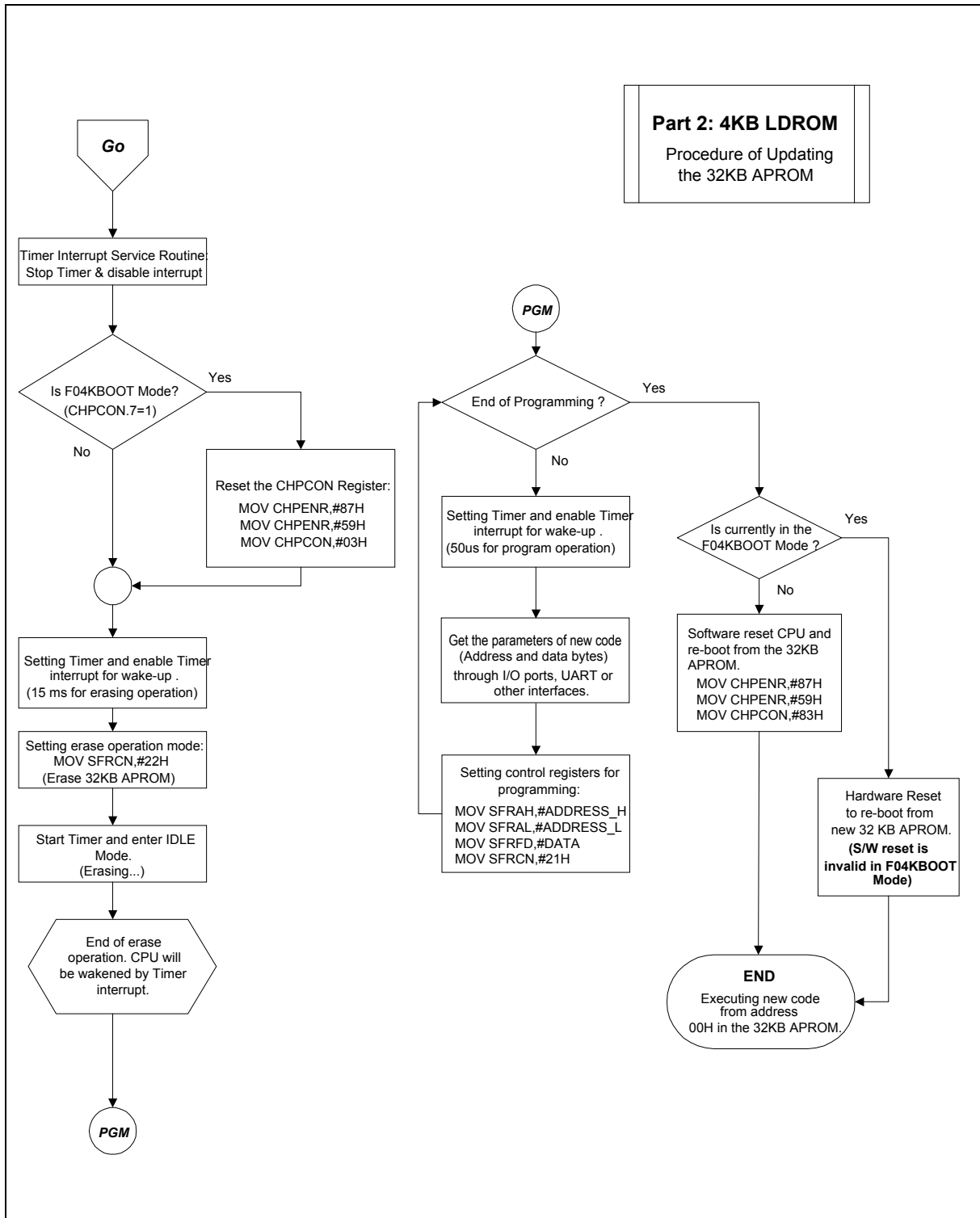



SECURITY

During the on-chip ROM programming mode, the ROM can be programmed and verified repeatedly. Until the code inside the ROM is confirmed OK, the code can be protected. The protection of ROM and those operations on it are described below.

The W78E65 has a Security Register that can be accessed in programming mode. Those bits of the Security Registers can not be changed once they have been programmed from high to low. They can only be reset through erase-all operation. The Security Register is located at the 0FFFFh of the LDROM space.

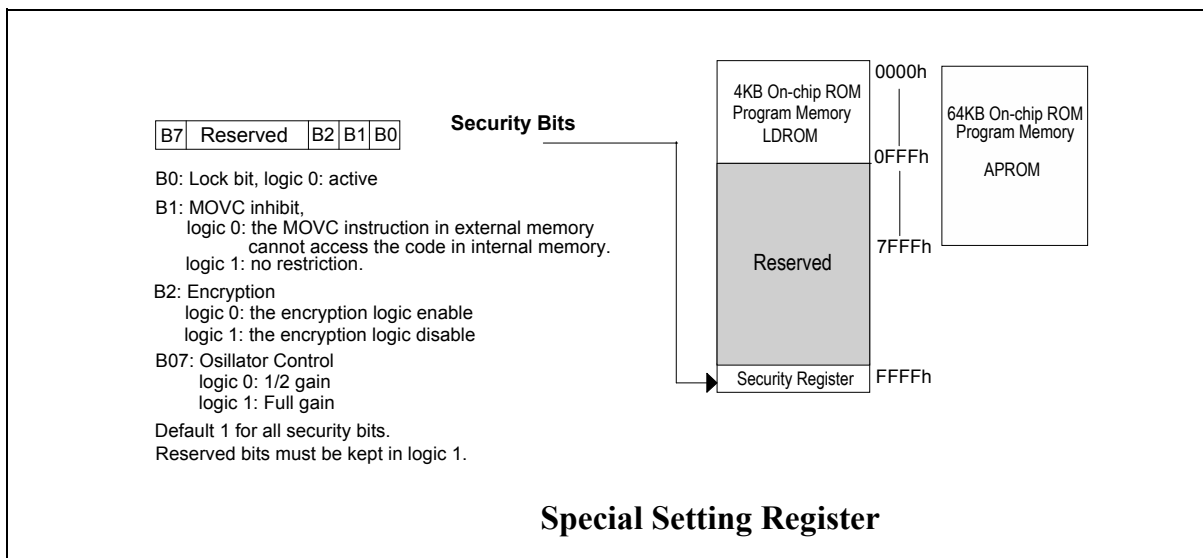

Lock bit

This bit is used to protect the customer's program code in the W78E65. It may be set after the programmer finishes the programming and verifies sequence. Once this bit is set to logic 0, both the ROM data and Security Register can not be accessed again.

MOVC Inhibit

This bit is used to restrict the accessible region of the MOVC instruction. It can prevent the MOVC instruction in external program memory from reading the internal program code. When this bit is set to logic 0, a MOVC instruction in external program memory space will be able to access code only in the external memory, not in the internal memory. A MOVC instruction in internal program memory space will always be able to access the ROM data in both internal and external memory. If this bit is logic 1, there are no restrictions on the MOVC instruction.

Encryption

This bit is used to enable/disable the encryption logic for code protection. Once encryption feature is enabled, the data presented on port 0 will be encoded via encryption logic. Only whole chip erase will reset this bit.



Oscillator Control

W78E65/E516 allow user to diminish the gain of on-chip oscillator amplifier by using programmer to set the bit B7 of security register. Once B7 is set to 0, a half of gain will be decreased. Care must be taken if user attempts to diminish the gain of oscillator amplifier, reducing a half of gain may improperly affect the external crystal operation at high frequency above 24 MHz. The value of R and C1, C2 may need some adjustment while running at lower gain.

ABSOLUTE MAXIMUM RATINGS

PARAMETER	SYMBOL	MIN.	MAX.	UNIT
DC Power Supply	V _{DD} -V _{SS}	-0.3	+6.0	V
Input Voltage	V _{IN}	V _{SS} -0.3	V _{DD} +0.3	V
Operating Temperature	T _A	0	70	°C
Storage Temperature	T _{ST}	-55	+150	°C

Note: Exposure to conditions beyond those listed under Absolute Maximum Ratings may adversely affect the life and reliability of the device.

DC CHARACTERISTICS

(V_{DD}-V_{SS}= 5V±10%, T_A= 25°C, F_{osc} = 20MHz, unless otherwise specified.)

Symbol	Parameter	Specification			Test Conditions
		Min	Max	Unit	
V _{DD}	Operating Voltage	4.5	5.5	V	RST=1, P0 = V _{DD}
I _{DD}	Operating Current	-	20	mA	No load V _{DD} =5.5V
I _{IDLE}	Idle Current	-	6	mA	Idle mode V _{DD} =5.5V
I _{PWDN}	Power Down Current	-	10	μA	Power-down mode V _{DD} =5.5V
I _{IN1}	Input Current P1, P2, P3, P4	-50	+10	μA	V _{DD} =5.5V V _{IN} =0V or V _{DD}
I _{IN2}	Input Current RST	-10	+300	μA	V _{DD} =5.5V 0<V _{IN} <V _{DD}
I _{LK}	Input Leakage Current P0, /EA	-10	+10	μA	V _{DD} =5.5V 0V<V _{IN} <V _{DD}
I _{TL} ^[4]	Logic 1 to 0 Transition Current P1, P2, P3, P4	-500	-	μA	V _{DD} =5.5V V _{IN} =2.0V
V _{IL1}	Input Low Voltage P0, P1, P2, P3, P4, /EA	0	0.8	V	V _{DD} =4.5V
V _{IL2}	Input Low Voltage RST	0	0.8	V	V _{DD} =4.5V
V _{IL3}	Input Low Voltage XTAL1 ^[4]	0	0.8	V	V _{DD} =4.5V
V _{IH1}	Input High Voltage P0, P1, P2, P3, P4, /EA	2.4	V _{DD} +0.2	V	V _{DD} =5.5V



V _{IH2}	Input High Voltage RST	3.5	V _{DD} +0.2	V	V _{DD} =5.5V
V _{IH3}	Input High Voltage XTAL1 ^[*4]	3.5	V _{DD} +0.2	V	V _{DD} =5.5V
V _{OL1}	Output Low Voltage P1, P2, P3, P4	-	0.45	V	V _{DD} =4.5V I _{OL} = +2mA
V _{OL2}	Output Low Voltage P0, ALE, /PSEN ^[*3]	-	0.45	V	V _{DD} =4.5V I _{OL} = +4mA
I _{sk1}	Sink current P1, P3, P4	4	12	mA	V _{DD} =4.5V V _{in} = 0.45V
I _{sk2}	Sink current P0, P2, ALE, /PSEN	10	20	mA	V _{DD} =4.5V V _{in} = 0.45V
V _{OH1}	Output High Voltage P1, P2, P3, P4	2.4	-	V	V _{DD} =4.5V I _{OH} = -100μA
V _{OH2}	Output High Voltage P0, ALE, /PSEN ^[*3]	2.4	-	V	V _{DD} =4.5V I _{OH} = -400μA
I _{sr1}	Source current P1, P2, P3, P4	-120	-250	uA	V _{DD} =4.5V V _{in} = 2.4V
I _{sr2}	Source current P0, P2, ALE, /PSEN	-8	-20	mA	V _{DD} =4.5V V _{in} = 2.4V

Notes:

*1. RST pin is a Schmitt trigger input.

*2. P0, ALE and /PSEN are tested in the external access mode.

*3. XTAL1 is a CMOS input.

*4. Pins of P1, P2, P3, P4 can source a transition current when they are being externally driven from 1 to 0.



AC CHARACTERISTICS

The AC specifications are a function of the particular process used to manufacture the part, the ratings of the I/O buffers, the capacitive load, and the internal routing capacitance. Most of the specifications can be expressed in terms of multiple input clock periods (TCP), and actual parts will usually experience less than a ± 20 nS variation. The numbers below represent the performance expected from a 0.6 micron CMOS process when using 2 and 4 mA output buffers.

Clock Input Waveform

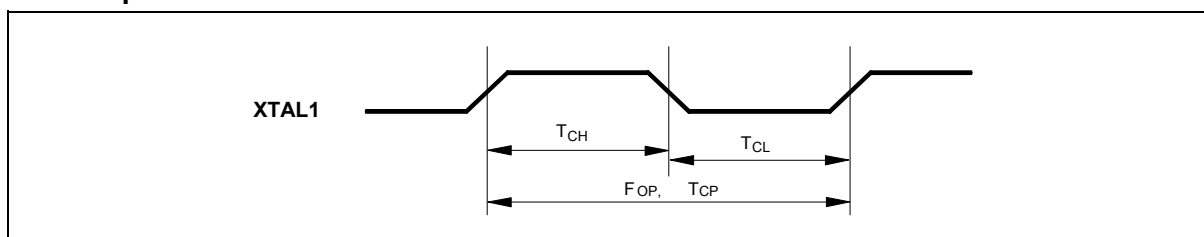

PARAMETER	SYMBOL	MIN.	TYP.	MAX.	UNIT	NOTES
Operating Speed	FOP	0	-	24	MHz	1
Clock Period	TCP	41.7	-	-	nS	2
Clock High	TCH	20	-	-	nS	3
Clock Low	TCL	20	-	-	nS	3

Notes:

1. The clock may be stopped indefinitely in either state.
2. The TCP specification is used as a reference in other specifications.
3. There are no duty cycle requirements on the XTAL1 input.

Program Fetch Cycle

PARAMETER	SYMBOL	MIN.	TYP.	MAX.	UNIT	NOTES
Address Valid to ALE Low	TAAS	1 TCP- Δ	-	-	nS	4
Address Hold from ALE Low	TAAH	1 TCP- Δ	-	-	nS	1, 4
ALE Low to $\overline{\text{PSEN}}$ Low	TAPL	1 TCP- Δ	-	-	nS	4
$\overline{\text{PSEN}}$ Low to Data Valid	TPDA	-	-	2 TCP	nS	2
Data Hold after $\overline{\text{PSEN}}$ High	TPDH	0	-	1 TCP	nS	3
Data Float after $\overline{\text{PSEN}}$ High	TPDZ	0	-	1 TCP	nS	
ALE Pulse Width	TALW	2 TCP- Δ	2 TCP	-	nS	4
$\overline{\text{PSEN}}$ Pulse Width	TPSW	3 TCP- Δ	3 TCP	-	nS	4

Notes:

1. P0.0–P0.7, P2.0–P2.7 remain stable throughout entire memory cycle.
2. Memory access time is 3 TCP.
3. Data have been latched internally prior to $\overline{\text{PSEN}}$ going high.
4. " Δ " (due to buffer driving delay and wire loading) is 20 nS.



Data Read Cycle

PARAMETER	SYMBOL	MIN.	TYP.	MAX.	UNIT	NOTES
ALE Low to \overline{RD} Low	TDAR	3 $T_{CP-\Delta}$	-	3 $T_{CP+\Delta}$	nS	1, 2
\overline{RD} Low to Data Valid	TDDA	-	-	4 T_{CP}	nS	1
Data Hold from \overline{RD} High	TDDH	0	-	2 T_{CP}	nS	
Data Float from \overline{RD} High	TDDZ	0	-	2 T_{CP}	nS	
\overline{RD} Pulse Width	TDRD	6 $T_{CP-\Delta}$	6 T_{CP}	-	nS	2

Notes:

1. Data memory access time is 8 T_{CP} .
2. " Δ " (due to buffer driving delay and wire loading) is 20 nS.

Data Write Cycle

PARAMETER	SYMBOL	MIN.	TYP.	MAX.	UNIT
ALE Low to \overline{WR} Low	TDAW	3 $T_{CP-\Delta}$	-	3 $T_{CP+\Delta}$	nS
Data Valid to \overline{WR} Low	TDAD	1 $T_{CP-\Delta}$	-	-	nS
Data Hold from \overline{WR} High	TDWD	1 $T_{CP-\Delta}$	-	-	nS
\overline{WR} Pulse Width	TDWR	6 $T_{CP-\Delta}$	6 T_{CP}	-	nS

Note: " Δ " (due to buffer driving delay and wire loading) is 20 nS.

Port Access Cycle

PARAMETER	SYMBOL	MIN.	TYP.	MAX.	UNIT
Port Input Setup to ALE Low	TPDS	1 T_{CP}	-	-	nS
Port Input Hold from ALE Low	TPDH	0	-	-	nS
Port Output to ALE	TPDA	1 T_{CP}	-	-	nS

Note: Ports are read during S5P2, and output data becomes available at the end of S6P2. The timing data are referenced to ALE, since it provides a convenient reference.



TIMING WAVEFORMS

Program Fetch Cycle

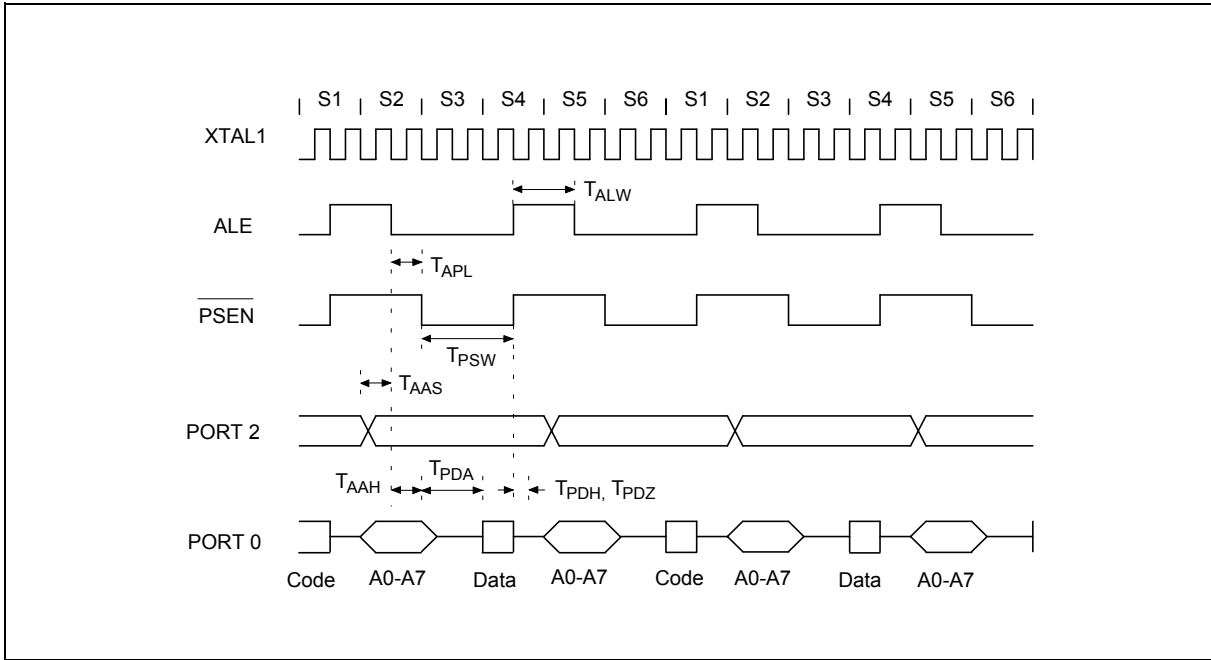

Data Read Cycle

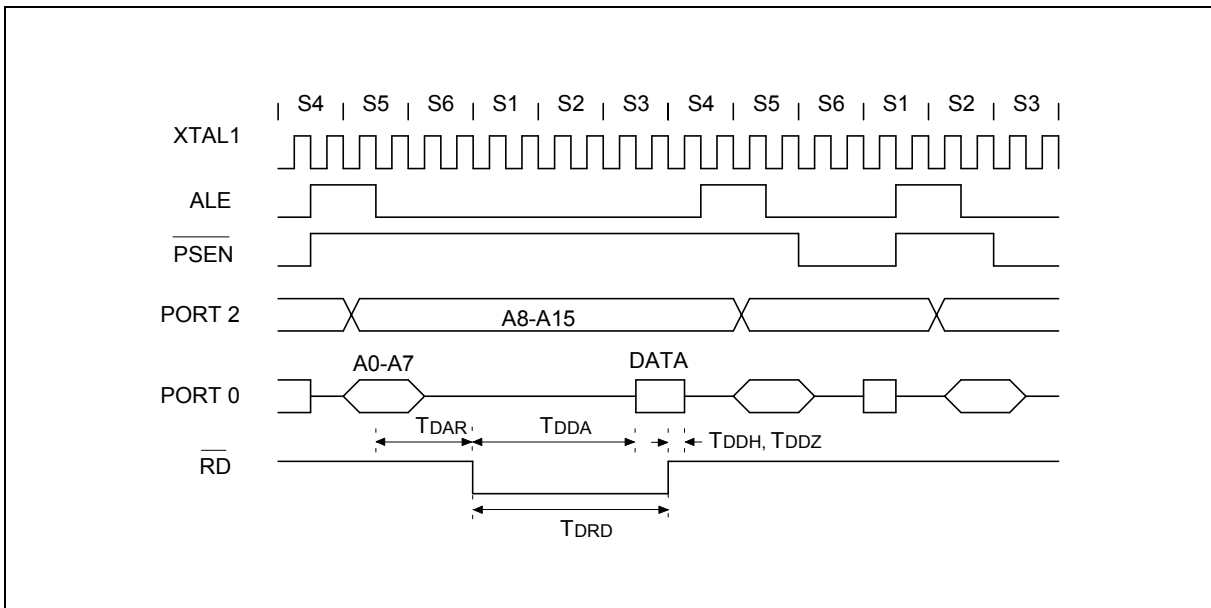



Timing Waveforms, continued

Data Write Cycle

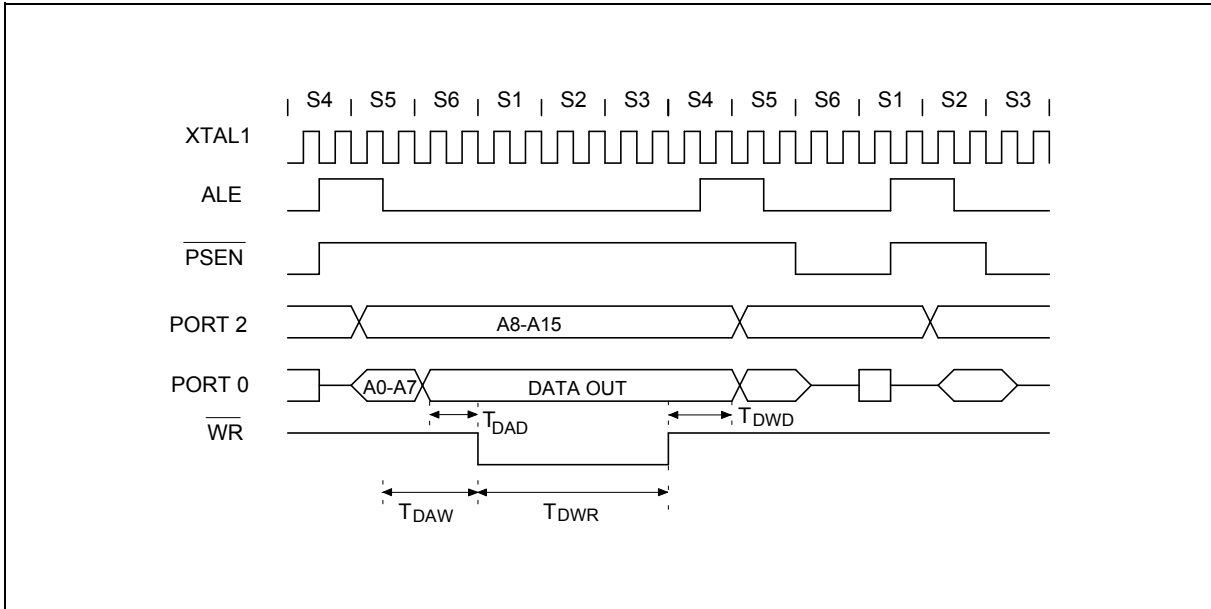

Port Access Cycle

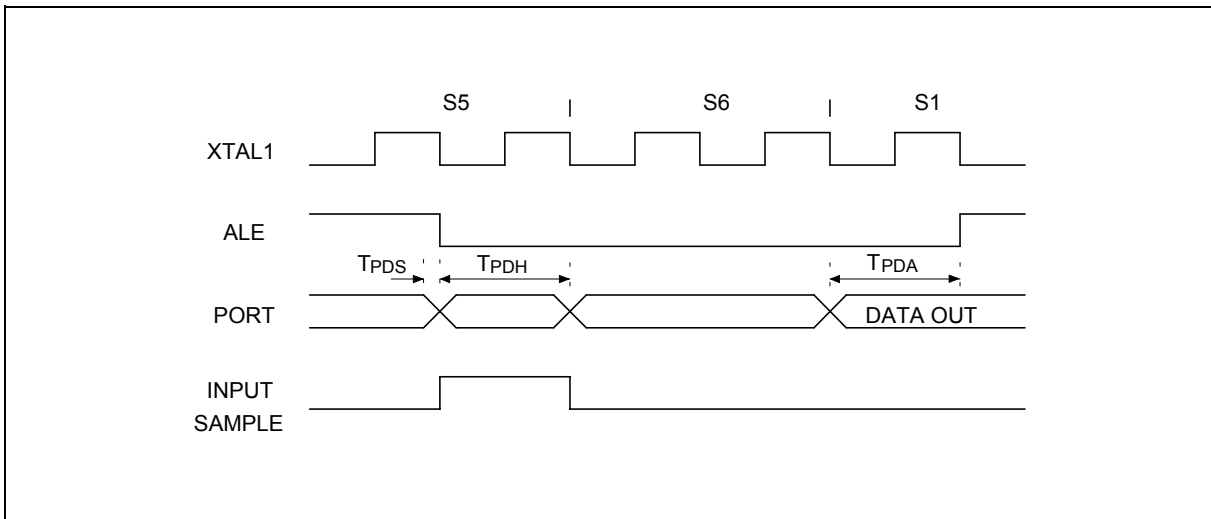



TYPICAL APPLICATION CIRCUIT

Expanded External Program Memory and Crystal

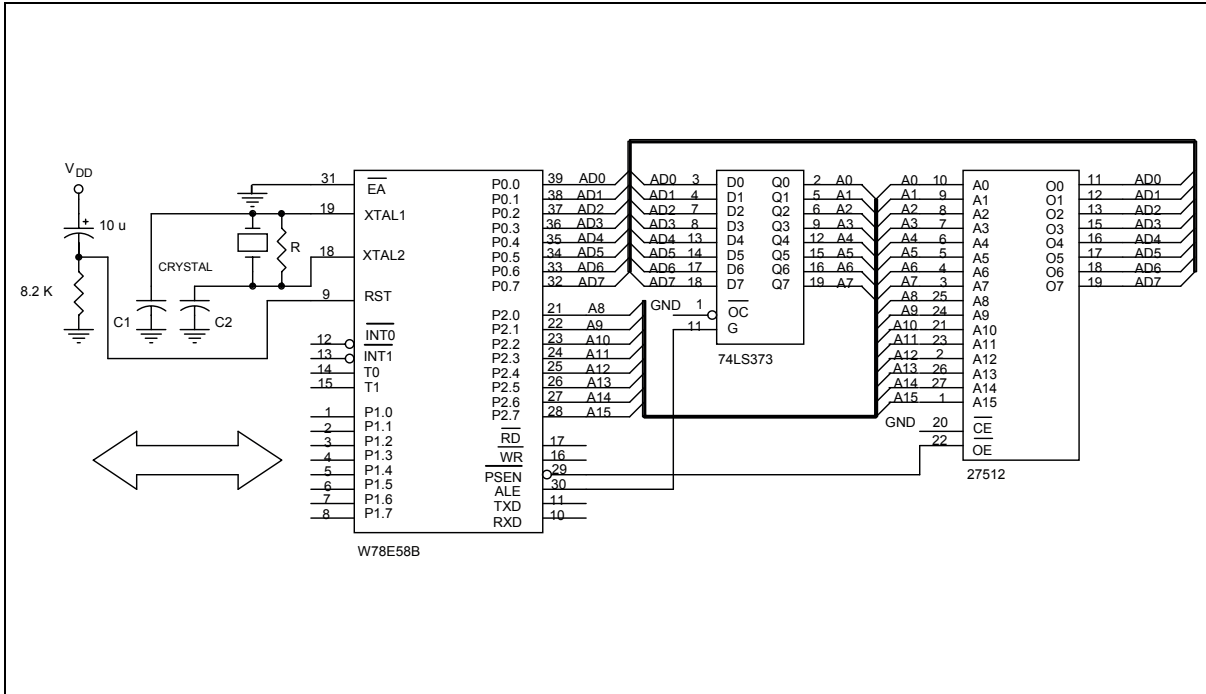

Figure A

CRYSTAL	C1	C2	R
6 MHz	47P	47P	-
16 MHz	30P	30P	-
24 MHz	15P	10P	-

Above table shows the reference values for crystal applications.

Notes:

1. C1, C2, R components refer to Figure A
2. Crystal layout must get close to XTAL1 and XTAL2 pins on user's application board.



Typical Application Circuit, continued

Expanded External Data Memory and Oscillator

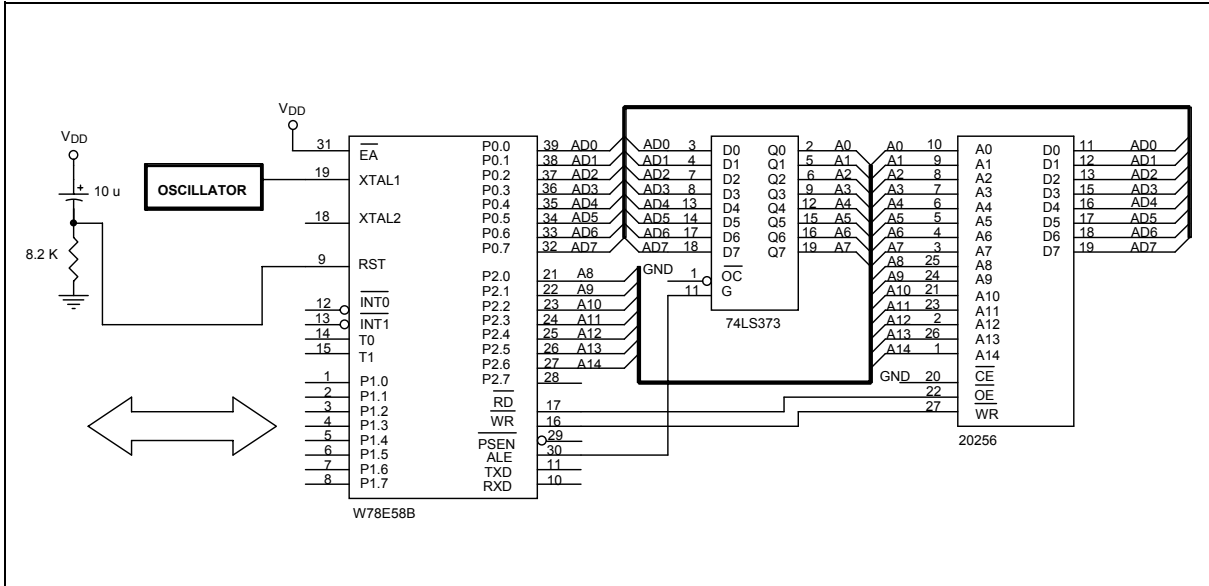
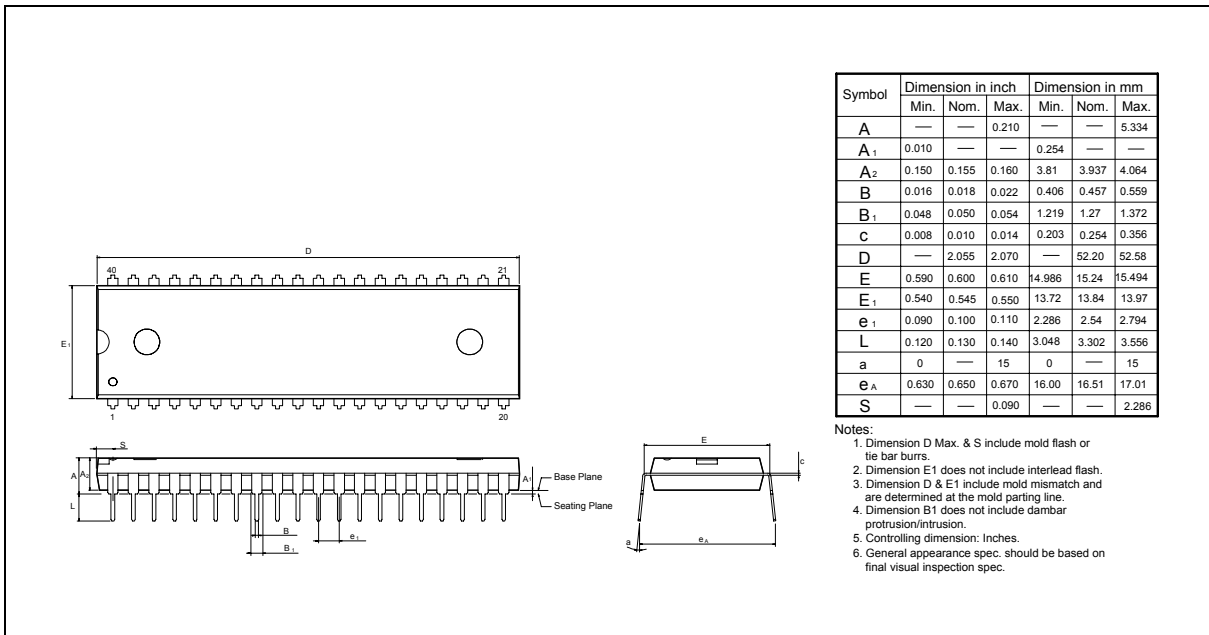

Figure B

PACKAGE DIMENSIONS

40-pin DIP





Package Dimensions, continued

44-pin PLCC

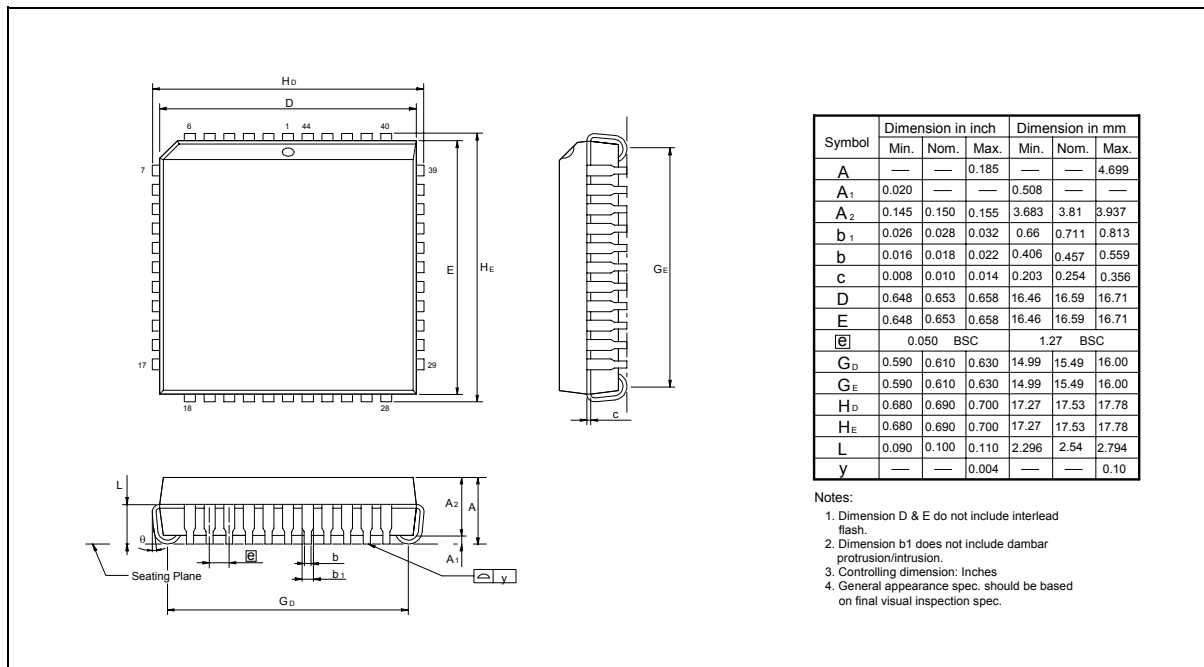

44-pin PQFP

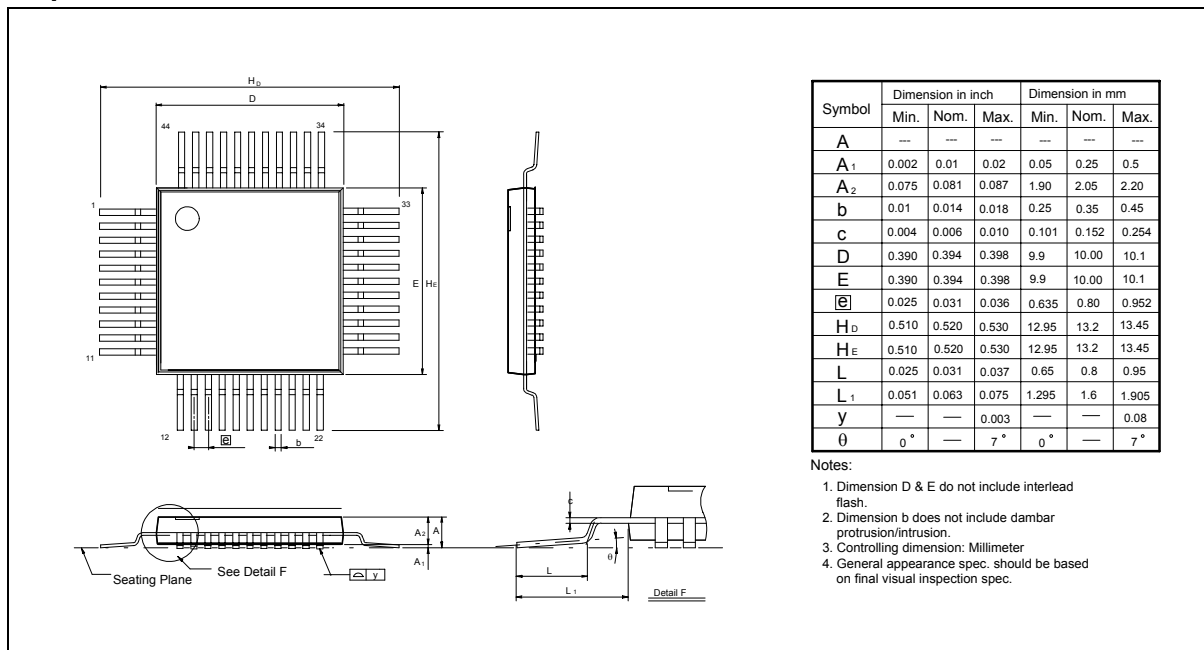



Application Note: In-system Programming Software Examples

This application note illustrates the in-system programmability of the Winbond W78E65 ROM microcontroller. In this example, microcontroller will boot from 64KB APROM bank and waiting for a key to enter in-system programming mode for re-programming the contents of 64KB APROM. While entering in-system programming mode, microcontroller executes the loader program in 4KB LDROM bank. The loader program erases the 64KB APROM then reads the new code data from external SRAM buffer (or through other interfaces) to update the 64KB APROM.

EXAMPLE 1:

```

;*****
;
;* Example of 64K APROM program: Program will scan the P1.0. if P1.0 = 0, enters in-system
;* programming mode for updating the content of APROM code else executes the current ROM code.
;* XTAL = 16 MHz
;*****
;
    .chip 8052
    .RAMCHK OFF
    .symbols

    CHPCON EQU BFH
    CHPENR EQU F6H
    SFRAL EQU C4H
    SFRAH EQU C5H
    SFRFD EQU C6H
    SFRCN EQU C7H

    ORG 0H
    LJMP 100H ; JUMP TO MAIN PROGRAM
;*****
;* TIMER0 SERVICE VECTOR ORG = 000BH
;*****
;
    ORG 00BH
    CLR TR0 ; TR0 = 0, STOP TIMER0
    MOV TL0,R6
    MOV TH0,R7
    RETI
;*****
;* 64K APROM MAIN PROGRAM
;*****
;
    ORG 100H

MAIN_64K:
    MOV A,P1 ; SCAN P1.0
    ANL A,#01H
    CJNE A,#01H,PROGRAM_64K ; IF P1.0 = 0, ENTER IN-SYSTEM PROGRAMMING MODE
    JMP NORMAL_MODE

PROGRAM_64K:
    MOV CHPENR,#87H ; CHPENR = 87H, CHPCON REGISTER WRTE ENABLE
    MOV CHPENR,#59H ; CHPENR = 59H, CHPCON REGISTER WRITE ENABLE
    MOV CHPCON,#03H ; CHPCON = 03H, ENTER IN-SYSTEM PROGRAMMING MODE
    MOV TCON,#00H ; TR = 0 TIMER0 STOP
    MOV IP,#00H ; IP = 00H
    MOV IE,#82H ; TIMER0 INTERRUPT ENABLE FOR WAKE-UP FROM IDLE MODE

```



```

MOV R6,#F0H           ; TL0 = F0H
MOV R7,#FFH           ; TH0 = FFH
MOV TL0,R6
MOV TH0,R7
MOV TMOD,#01H         ; TMOD = 01H, SET TIMER0 A 16-BIT TIMER
MOV TCON,#10H         ; TCON = 10H, TR0 = 1,GO
MOV PCON,#01H         ; ENTER IDLE MODE FOR LAUNCHING THE IN-SYSTEM
                       ; PROGRAMMING
;*****
;
;* Normal mode 64KB APROM program: depending user's application
;*****
NORMAL_MODE:
    .           ; User's application program
    .
    .
    .
EXAMPLE 2:
;***** Example of 4
KB LDROM program: This loader program will erase the 64KB APROM first, then reads the new ;* code from external SRAM
and program them into 32 KB APROM bank. XTAL = 16 MHz
;*****
;
    .chip 8052
    .RAMCHK OFF
    .symbols

    CHPCON EQU BFH
    CHPENR EQU F6H
    SFRAL EQU C4H
    SFRAH EQU C5H
    SFRFD EQU C6H
    SFRCN EQU C7H

    ORG 000H
    LJMP 100H           ; JUMP TO MAIN PROGRAM
;*****
;* 1. TIMER0 SERVICE VECTOR ORG = 0BH
;*****
    ORG 000BH
    CLR TR0             ; TR0 = 0, STOP TIMER0
    MOV TL0,R6
    MOV TH0,R7
    RETI
;*****
;* 4KB LDROM MAIN PROGRAM
;*****
    ORG 100H

```



MAIN_4K:

```

MOV SP,#C0H
MOV CHPENR,#87H ; CHPENR = 87H, CHPCON WRITE ENABLE.
MOV CHPENR,#59H ; CHPENR = 59H, CHPCON WRITE ENABLE.
MOV CHPCON,#03H ; CHPCON = 03H, ENABLE IN-SYSTEM PROGRAMMING.
MOV CHPENR,#00H ; DISABLE CHPCON WRITE ATTRIBUTE

MOV TCON,#00H ; TCON = 00H, TR = 0 TIMER0 STOP
MOV TMOD,#01H ; TMOD = 01H, SET TIMER0 A 16BIT TIMER
MOV IP,#00H ; IP = 00H
MOV IE,#82H ; IE = 82H, TIMER0 INTERRUPT ENABLED
MOV R6,#F0H
MOV R7,#FFH
MOV TL0,R6
MOV TH0,R7
MOV TCON,#10H ; TCON = 10H, TR0 = 1, GO
MOV PCON,#01H ; ENTER IDLE MODE

```

UPDATE_64K:

```

MOV TCON,#00H ; TCON = 00H , TR = 0 TIM0 STOP
MOV IP,#00H ; IP = 00H
MOV IE,#82H ; IE = 82H, TIMER0 INTERRUPT ENABLED
MOV TMOD,#01H ; TMOD = 01H, MODE1
MOV R6,#E0H ; SET WAKE-UP TIME FOR ERASE OPERATION, ABOUT 15 mS. DEPENDING
; ON USER'S SYSTEM CLOCK RATE.

MOV R7,#B1H
MOV TL0,R6
MOV TH0,R7

```

ERASE_P_4K:

```

MOV SFRCN,#22H ; SFRCN(C7H) = 22H ERASE 64K
MOV TCON,#10H ; TCON = 10H, TR0 = 1,GO
MOV PCON,#01H ; ENTER IDLE MODE (FOR ERASE OPERATION)

```

```

;*****
;
;* BLANK CHECK
;*****
;

```

```

MOV SFRCN,#0H ; READ 64KB APROM MODE
MOV SFRAH,#0H ; START ADDRESS = 0H
MOV SFRAL,#0H
MOV R6,#FEH ; SET TIMER FOR READ OPERATION, ABOUT 1.5 μS.
MOV R7,#FFH
MOV TL0,R6
MOV TH0,R7

```

BLANK_CHECK_LOOP:

```

SETB TR0 ; ENABLE TIMER 0
MOV PCON,#01H ; ENTER IDLE MODE
MOV A,SFRFD ; READ ONE BYTE
CJNE A,#FFH,BLANK_CHECK_ERROR
INC SFRAL ; NEXT ADDRESS
MOV A,SFRAL
JNZ BLANK_CHECK_LOOP
INC SFRAH
MOV A,SFRAH

```



```
CJNE A,#80H,BLANK_CHECK_LOOP ; END ADDRESS = 7FFFH
JMP PROGRAM_64KROM
```

```
BLANK_CHECK_ERROR:
```

```
MOV P1,#F0H
MOV P3,#F0H
JMP $
```

```
*****
;
; * RE-PROGRAMMING 64KB APROM BANK
;
*****
```

```
PROGRAM_64KROM:
```

```
MOV DPTR,#0H ; THE ADDRESS OF NEW ROM CODE
MOV R2,#00H ; TARGET LOW BYTE ADDRESS
MOV R1,#00H ; TARGET HIGH BYTE ADDRESS
MOV DPTR,#0H ; EXTERNAL SRAM BUFFER ADDRESS
MOV SFRAH,R1 ; SFRAH, TARGET HIGH ADDRESS
MOV SFRCN,#21H ; SFRCN(C7H) = 21 (PROGRAM 64K)
MOV R6,#BEH ; SET TIMER FOR PROGRAMMING, ABOUT 50 μS.
MOV R7,#FFH
MOV TL0,R6
MOV TH0,R7
```

```
PROG_D_64K:
```

```
MOV SFRAL,R2 ; SFRAL(C4H) = LOW BYTE ADDRESS
MOVX A,@DPTR ; READ DATA FROM EXTERNAL SRAM BUFFER. BY ACCORDING USER?
; CIRCUIT, USER MUST MODIFY THIS INSTRUCTION TO FETCH CODE
MOV SFRFD,A ; SFRFD(C6H) = DATA IN
MOV TCON,#10H ; TCON = 10H, TR0 = 1,GO
MOV PCON,#01H ; ENTER IDLE MODE (PROGAMMING)
INC DPTR
INC R2
CJNE R2,#0H,PROG_D_64K
INC R1
MOV SFRAH,R1
CJNE R1,#80H,PROG_D_64K
```

```
*****
;
; * VERIFY 64KB APROM BANK
;
*****
```

```
MOV R4,#03H ; ERROR COUNTER
MOV R6,#FEH ; SET TIMER FOR READ VERIFY, ABOUT 1.5 μS.
MOV R7,#FFH
MOV TL0,R6
MOV TH0,R7
MOV DPTR,#0H ; The start address of sample code
MOV R2,#0H ; Target low byte address
MOV R1,#0H ; Target high byte address
MOV SFRAH,R1 ; SFRAH, Target high address
MOV SFRCN,#00H ; SFRCN = 00 (Read ROM CODE)
```

```
READ_VERIFY_64K:
```

```
MOV SFRAL,R2 ; SFRAL(C4H) = LOW ADDRESS
MOV TCON,#10H ; TCON = 10H, TR0 = 1,GO
```



```

MOV PCON,#01H
INC R2
MOVX A,@DPTR
INC DPTR
CJNE A,SFRFD,ERROR_64K
CJNE R2,#0H,READ_VERIFY_64K
INC R1
MOV SFRAH,R1
CJNE R1,#80H,READ_VERIFY_64K
    
```

```

;*****
;
;* PROGRAMMING COMPLETELY, SOFTWARE RESET CPU
;*****
    
```

```

MOV CHPENR,#87H ; CHPENR = 87H
MOV CHPENR,#59H ; CHPENR = 59H
MOV CHPCON,#83H ; CHPCON = 83H, SOFTWARE RESET.
    
```

ERROR_64K:

```

DJNZ R4,UPDATE_64K ; IF ERROR OCCURS, REPEAT 3 TIMES.
. ; IN-SYSTEM PROGRAMMING FAIL, USER'S PROCESS TO DEAL WITH IT.
.
.
.
    
```



Headquarters

No. 4, Creation Rd. III,
 Science-Based Industrial Park,
 Hsinchu, Taiwan
 TEL: 886-3-5770066
 FAX: 886-3-5792766
<http://www.winbond.com.tw/>
 Voice & Fax-on-demand: 886-2-27197006

Taipei Office

11F, No. 115, Sec. 3, Min-Sheng East Rd.,
 Taipei, Taiwan
 TEL: 886-2-27190505
 FAX: 886-2-27197502

Winbond Electronics (H.K.) Ltd.

Unit 9-15, 22F, Millennium City,
 No. 378 Kwun Tong Rd;
 Kowloon, Hong Kong
 TEL: 852-27513100
 FAX: 852-27552064

Winbond Electronics North America Corp.

Winbond Memory Lab.
Winbond Microelectronics Corp.
Winbond Systems Lab.
 2727 N. First Street, San Jose,
 CA 95134, U.S.A.
 TEL: 408-9436666
 FAX: 408-5441798

Note: All data and specifications are subject to change without notice.