

C8051F970 DEVELOPMENT KIT USER'S GUIDE

1. Introduction

The C8051F970 Development Kit provides an evaluation and development platform for the C8051F97x MCUs. The board has a particular focus on capacitive sensing to highlight the 43 Capacitive Sense input channels available on the C8051F970 MCU.

1.1. Key Features

The key features of the C8051F970 Development Kit are:

- Silicon Labs EFM32 C8051F970 microcontroller with 32 kB flash and 8 kB RAM.
- Capacitive sensing 4 x 5 button matrix and slider highlight the unique Capacitive Sense module.
- Isolated power domains for the LEDs and the MCU to enable easy power measurement.
- Port headers for prototyping of custom hardware.

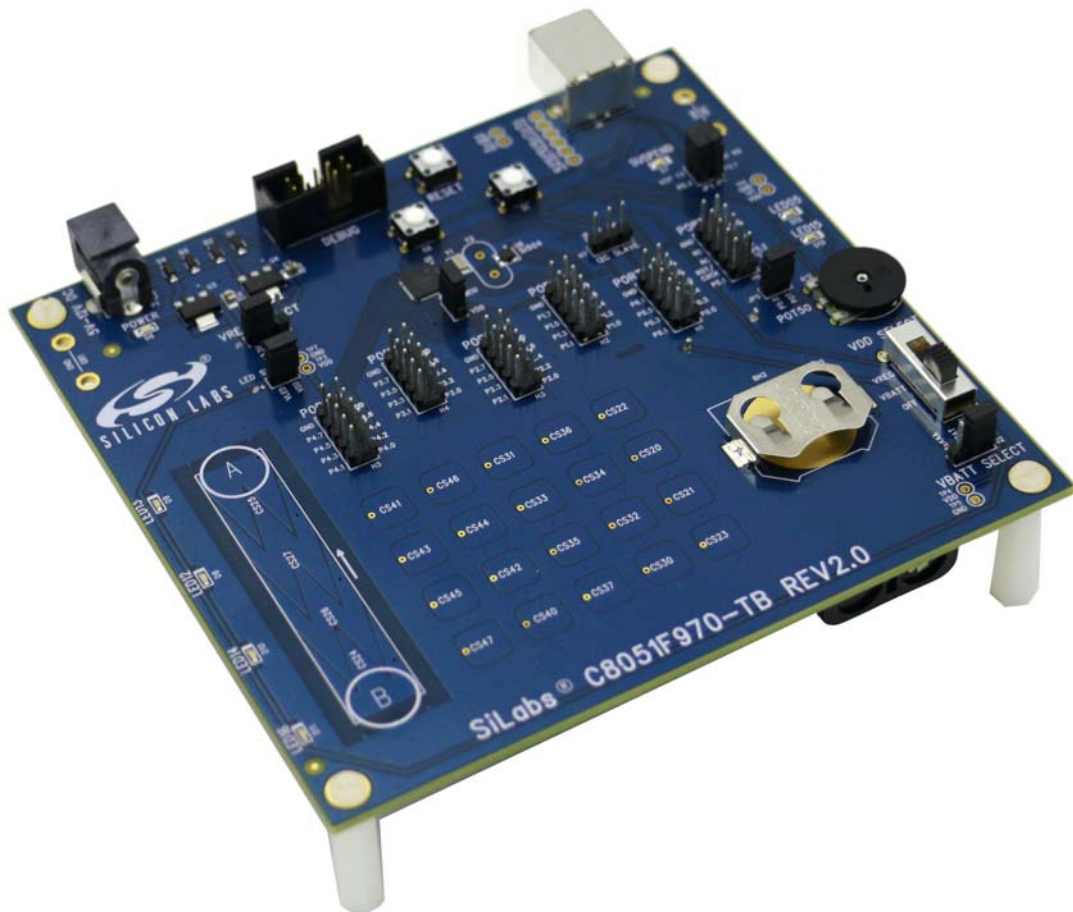

Figure 1. C8051F970 Target Board

2. Relevant Documents

This document provides a hardware overview for the C8051F970 Target Board in the Development Kit. Additional information on Simplicity Studio, Capacitive Sense Profiler, and the Capacitive Sense firmware library can be found in the documents listed in this section.

2.1. Getting Started

For step-by-step information on getting started with the C8051F970 DK, see the C8051F970 Development Kit Quick Start Guide. This document can be accessed in Simplicity Studio by selecting or detecting a C8051F97x device and clicking the **Quick Start Guide** button.

2.2. Simplicity Studio

Simplicity Studio can be downloaded from www.silabs.com/simplicity-studio. More information on Simplicity Studio can be found in the included help (**Help**→**Help Contents** or **Help**→**Search**) or in the following document:

- **AN0822: *Simplicity Studio User's Guide*** — Contains basic information, tips, and tricks for using Simplicity Studio.

This document can be found at www.silabs.com/8bit-appnotes or using the **Application Notes** tile in Simplicity Studio.

2.3. Capacitive Sense

The Capacitive Sense Profiler and Capacitive Sense library are documented in:

- **AN0828: *Capacitive Sensing Library Overview*** — An overview of the capacitive sensing library, including basic tips and tricks on using the profiler tool.
- **AN0829: *Capacitive Sensing Library Configuration Guide*** — Describes how to configure the capacitive sensing library for different application requirements

These documents can be found at www.silabs.com/8bit-appnotes or using the **Application Notes** tile in Simplicity Studio.

2.4. Application Notes

All 8-bit Application Notes can be found at www.silabs.com/8bit-appnotes or using the **Application Notes** tile in Simplicity Studio.

3. Hardware Setup

Refer to Figure 2 for a diagram of the hardware configuration.

1. Connect the USB Debug Adapter to the 10-pin debug connector (**DEBUG**, H8) on the MCU card using the 10-pin ribbon cable.
2. Connect the USB Debug Adapter to a USB Port on the PC.
3. Ensure the **VDD Select** switch (SW1) is in the top VREG position.
4. Verify that the JP3 power measurement jumper is populated.
5. Power the board through the power connector (P1) using the supplied 9 V ac/dc adapter.

Notes:

- Use the **Reset** button in the IDE to reset the target when connected using a USB Debug Adapter.
- Remove power from the target board and the USB Debug Adapter before connecting or disconnecting the ribbon cable from the target board. Connecting or disconnecting the cable when the devices have power can damage the device and/or the USB Debug Adapter.

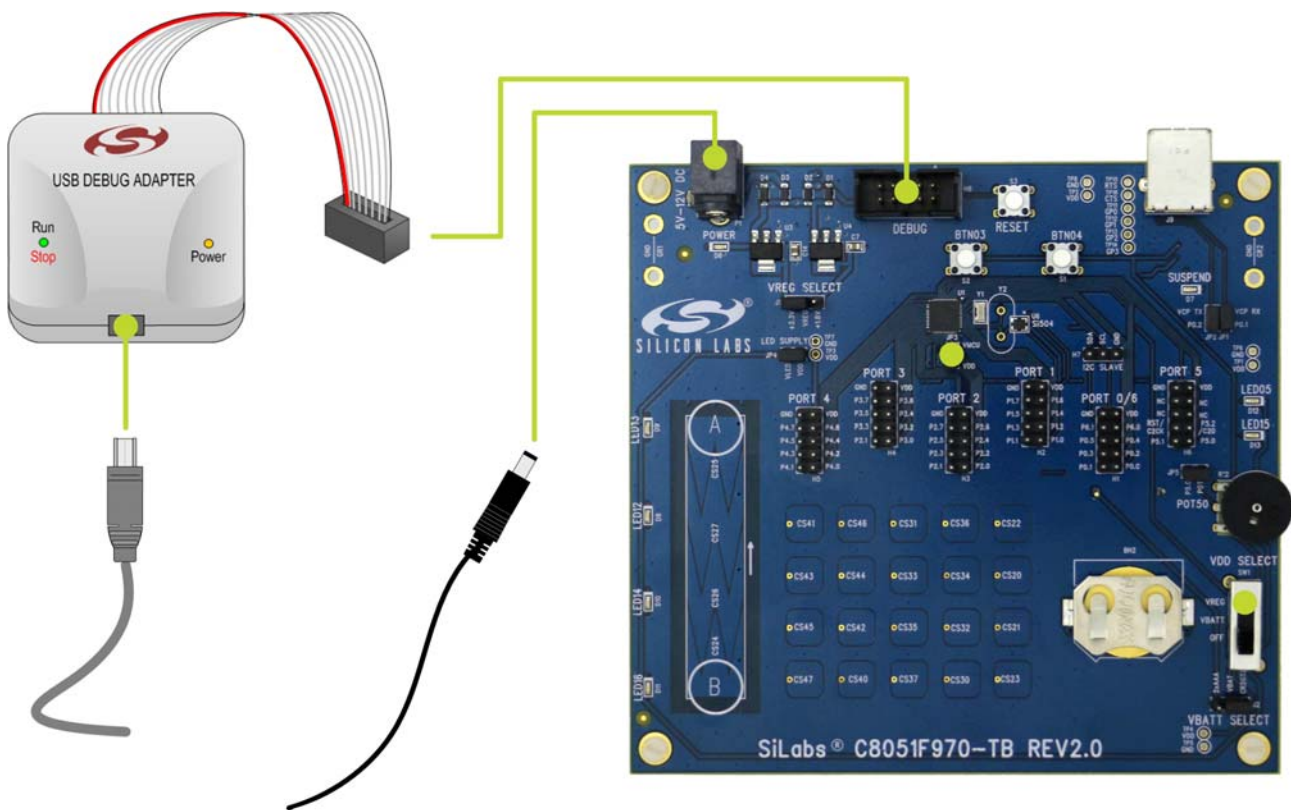

Figure 2. Hardware Setup

4. Software Setup

Simplicity Studio greatly reduces development time and complexity with Silicon Labs EFM32 and 8051 MCU products by providing a high-powered IDE, tools for hardware configuration, and links to helpful resources, all in one place.

Once Simplicity Studio is installed, the application itself can be used to install additional software and documentation components to aid in the development and evaluation process.

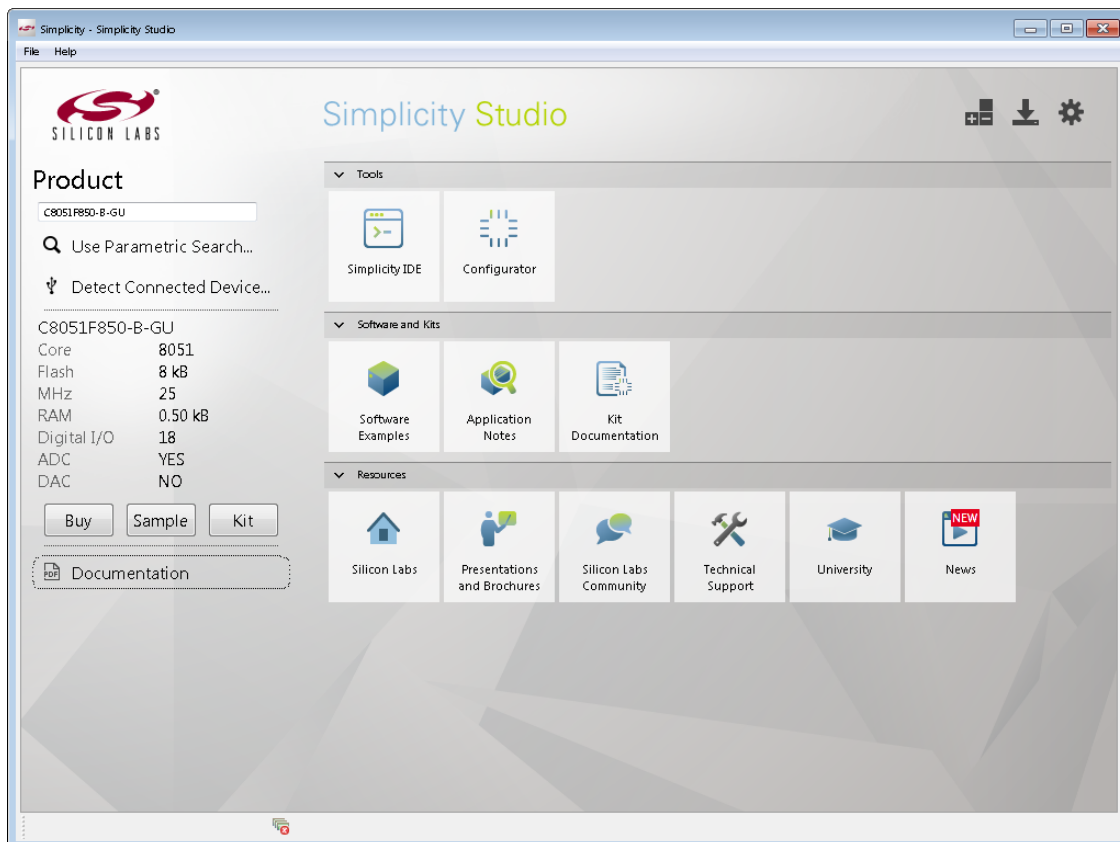

Figure 3. Simplicity Studio

The following Simplicity Studio components are required for the C8051F970 Development Kit:

- 8051 Products Part Support
- Simplicity Developer Platform

Download and install Simplicity Studio from www.silabs.com/8bit-software or www.silabs.com/simplicity-studio. Once installed, run Simplicity Studio by selecting **Start**→**Silicon Labs**→**Simplicity Studio**→**Simplicity Studio** from the start menu or clicking the **Simplicity Studio** shortcut on the desktop. Follow the instructions to install the software and click **Simplicity IDE** to launch the IDE.

The first time the project creation wizard runs, the **Setup Environment** wizard will guide the user through the process of configuring the build tools and SDK selection.

In the **Part Selection** step of the wizard, select from the list of installed parts only the parts to use during development. Choosing parts and families in this step affects the displayed or filtered parts in the later device selection menus. Choose the C8051F97x family by checking the **C8051F97x** check box. Modify the part selection at any time by accessing the **Part Management** dialog from the **Window**→**Preferences**→**Simplicity Studio**→**Part Management** menu item.

Simplicity Studio can detect if certain toolchains are not activated. If the **Licensing Helper** is displayed after completing the **Setup Environment** wizard, follow the instructions to activate the toolchain.

4.1. Loading a Demo

To download a demo to the board:

1. Click the **Detect Connected Device** button from the Simplicity Studio home screen.

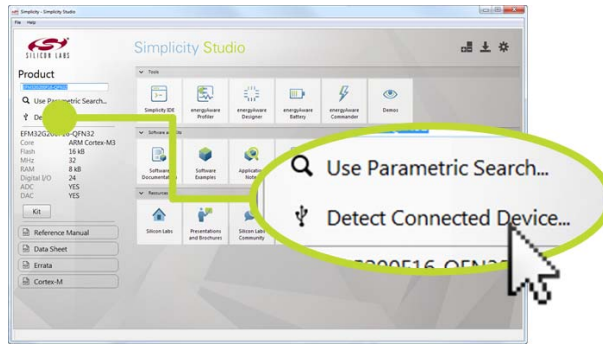

2. Click the **Demos** tile from the Simplicity Studio home screen.

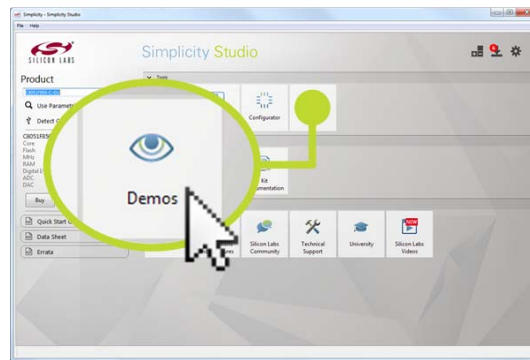

3. Select the desired demo from the list. For example, click the **Capacitive Sense (No Overlay)** demo for download to the board. A description of the demo and instructions are available in the lower area of the window.

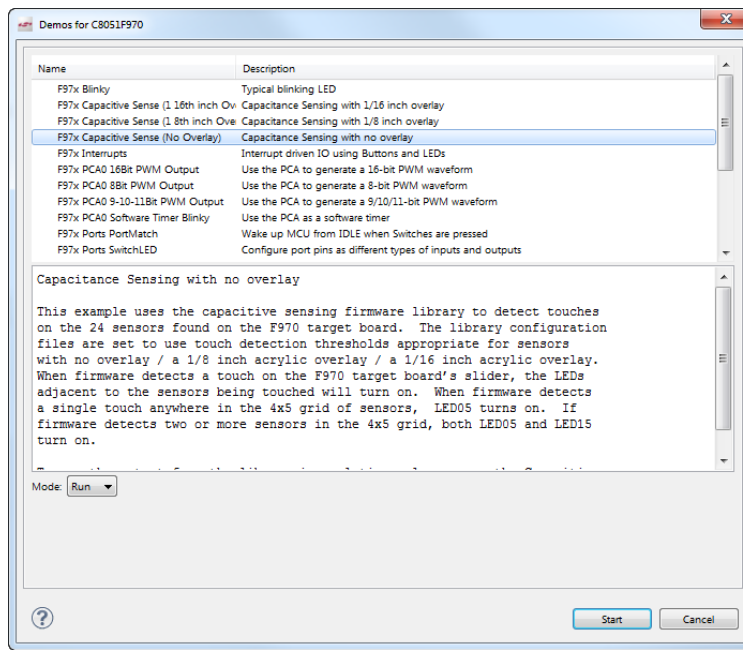

4. Click the **Start** button. This will download the demo to the board and start it running.

4.2. Building the Blinky Example

Each project has its own source files, target configuration, SDK configuration, and build configurations such as the **Debug** and **Release** build configurations. The IDE can be used to manage multiple projects in a collection called a workspace. Workspace settings are applied globally to all projects within the workspace. This can include settings such as key bindings, window preferences, and code style and formatting options. Project actions, such as build and debug are context sensitive. For example, the user must select a project in the **Project Explorer** view in order to build that project.

To create a project based on the Blinky example:

1. Click the **Software Examples** tile from the Simplicity Studio home screen.
2. In the **Kit** drop-down, select **C8051F970 Development Kit**, in the **Part** drop-down, select **C8051F970**, and in the **SDK** drop-down, select the desired SDK. Click **Next**.
3. Select **Example** and click **Next**.
4. Under **C8051F970 Development Kit** in the **Blinky** folder, select **F97x Blinky** and click **Finish**.
5. Click on the project in the **Project Explorer** and click **Build**, the hammer icon in the top bar. Alternatively, go to **Project**→**Build Project**.
6. Click **Debug** to download the project to the hardware and start a debug session.
7. Press the **Resume** button to start the code running. The LED should blink.



8. Press the **Suspend** button to stop the code.



9. Press the **Reset the device** button to reset the target MCU.



10. Press the **Disconnect** button to return to the development perspective.



4.3. Simplicity Studio Help

Simplicity Studio includes detailed help information and device documentation within the tool. The help contains descriptions for each dialog window. To view the documentation for a dialog, click the question mark icon in the window:



This will open a pane specific to the dialog with additional details.

The documentation within the tool can also be viewed by going to **Help**→**Help Contents** or **Help**→**Search**.

4.4. CP210x USB to UART VCP Driver Installation

The target board includes a Silicon Labs CP210x USB-to-UART Bridge Controller. Device drivers for the CP210x need to be installed before the PC software can communicate with the MCU through the UART interface. Download the latest drivers from the website (www.silabs.com/vcpdrivers).

1. Download the drivers from the website and unzip the files to a location and run the appropriate installer for the system (x86 or x64).
 2. Accept the license agreement and follow the steps to install the driver on the system. The installer will let you know when your system is up to date. The driver files included in this installation have been certified by Microsoft.
 3. To complete the installation process, connect the included USB cable between the host computer and the USB connector (J9) on the target board. Windows will automatically finish the driver installation. Information windows will pop up from the taskbar to show the installation progress.
- If needed, the driver files can be uninstalled by selecting **Windows Driver Package—Silicon Laboratories...** option in the **Programs and Features** window.

C8051F970DK-UG

5. C8051F970 Target Board Overview

The C8051F970 target board enables application development on the C8051F97x MCU device family. Figure 4 and Figure 5 highlight the C8051F970 target board features.

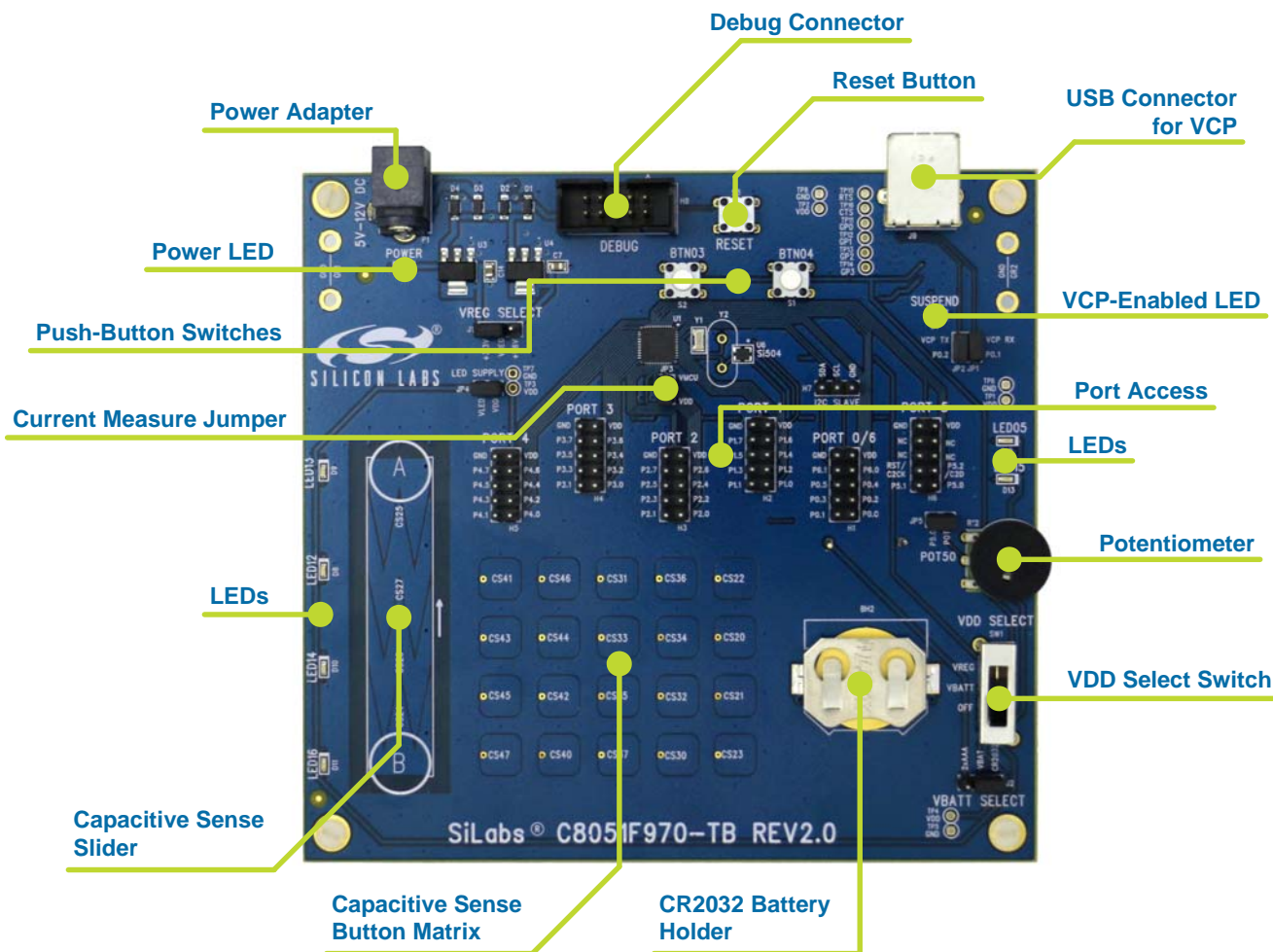

Figure 4. C8051F970 Target Board Features—Front

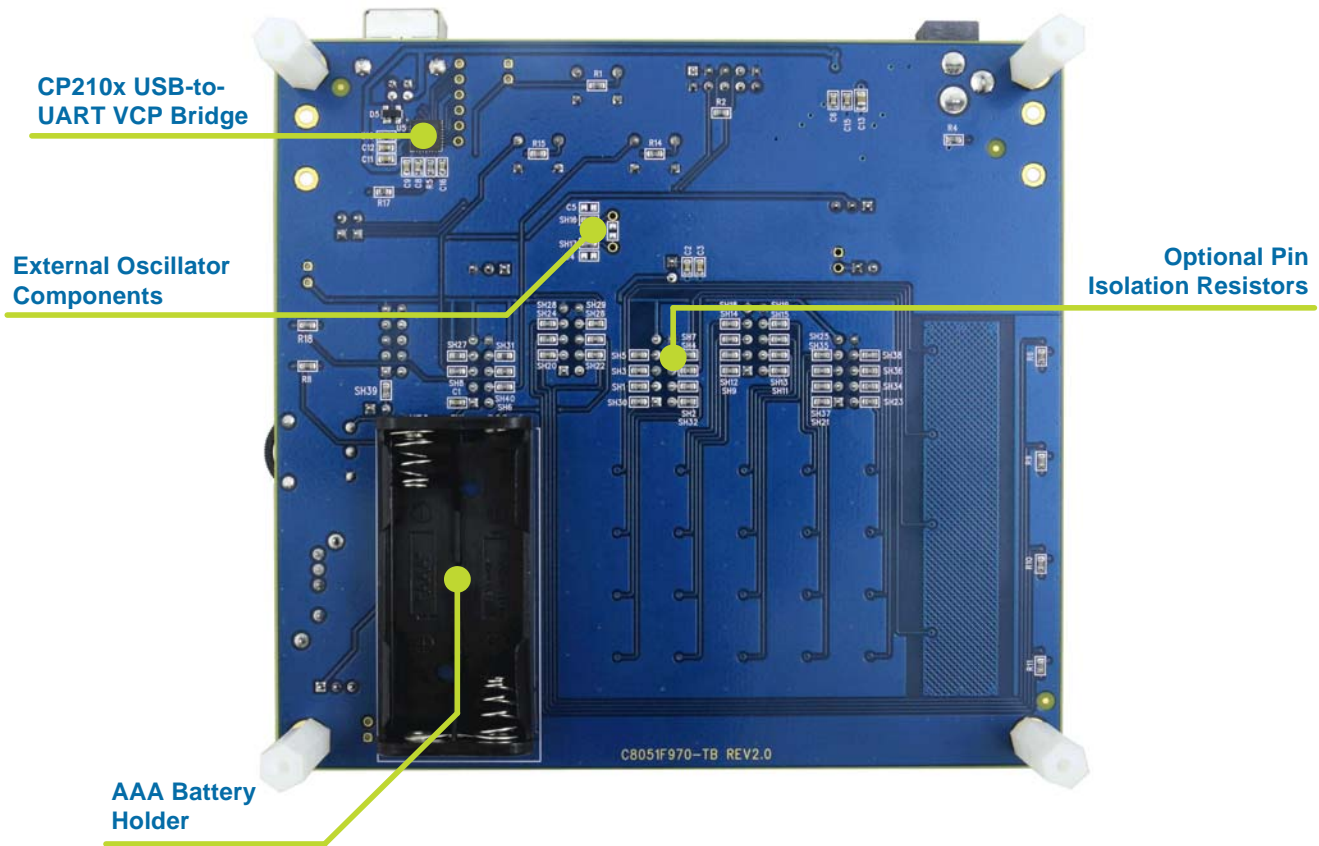

Figure 5. C8051F970 Target Board Features—Back

5.1. Push-Button Switches and LEDs (S1-2, DS8-13)

The C8051F970 target board has two push-button switches and six LEDs. The switches are normally open and pull the pin voltage to ground when pressed. The LEDs connect to VDD through a current-limiting resistor and turn on when the corresponding port pin is low.

Each pin has a zero ohm resistor that can be used to disconnect the switches and LEDs from the GPIO pins.

Table 1. Switch and LED Pin Descriptions

MCU Pin	Function
P1.2	Red LED DS8 (LED12)
P1.3	Red LED DS9 (LED13)
P1.4	Red LED DS10 (LED14)
P1.6	Red LED DS11 (LED16)
P0.5	Red LED DS12 (LED05)
P1.5	Red LED DS13 (LED15)
P0.4	Switch S1 (BTN04)
P0.3	Switch S2 (BTN03)

5.2. Potentiometer (R12)

The potentiometer is available on P5.0. To use the potentiometer, install a shorting block on JP5 to connect P5.0 to the potentiometer.

The potentiometer is referenced to P0.0, which is the voltage reference pin. Since the voltage reference can only source ~250 μ A, the simplest way to use the potentiometer is to turn on the P0.0 driver and set it to a logic high using the port registers. The most accurate way to use the potentiometer is to externally connect P0.0 to VDD.

5.3. Capacitive Sense Buttons (CS20-27, CS30-37, CS40-47)

The capacitive sensing buttons demonstrate the C8051F970 Capacitive Sense module for use with buttons and sliders. More information on the capacitive sense library can be found in 2.3. "Capacitive Sense," on page 2.

5.4. Power (SW1, J1, and J2)

The VDD power supply has three power options: on-board +3.3 V or +1.8 V regulator power, battery power, or off. The **VDD Select** switch (SW1) is used to select between the two options.

The +3.3 V or +1.8 V regulator power option is the upper **VREG** position and allows the board to be powered from a diode-OR of three power sources: 9 V Power Adapter (P1), the USB connector (J9), or the USB Debug Adapter (H8). Once the **VDD Select** switch is in the **VREG** position, the VREG Select header (J1) selects between +3.3 V or +1.8 V.

The middle **VBATT** option allows the board to be powered from either two AAA batteries (BH1) or a CR2032 coin cell (BH2). When the **VDD Select** switch is in the **VBATT** position, J2 selects between a CR2032 or two AAA batteries

The bottom **OFF** option disconnects the board power.

5.5. Power LED (D6)

The blue power LED provides visual feedback when the board is powered through USB, the 9 V power adapter, or the USB Debug Adapter. This LED is not tied to the battery power net to conserve energy. The power LED indicates that power is available on the board and the VDD Power Select switch must be configured properly to power the MCU.

5.6. Power Measurement Jumper (JP3)

The power measurement jumper (JP3) allows for easy access to measure the VDD current of the MCU. The shorting block for this header is populated by default. The side labeled VMCU is the side isolated to the C8051F970 MCU. To measure the supply current, remove the corresponding shorting block and connect a current measurement device across the unpopulated header.

The voltage supply prior to the jumper is the VDD net, which supplies all of the external LEDs, switches, USB COM, and reset pull-up. The VDD_MCU net after the jumper only connects to the MCU.

5.7. Debug Header (H8)

The shrouded 10-pin debug header supports the Silicon Labs USB Debug Adapter. This connector provides a C2 debug connection to the C8051F970 on the target board.

5.8. Reset Button (S3)

The reset push-button switch is to the right of the debug header (H8). Pushing this button will always reset the MCU. Note that pushing this button while the IDE is connected to the MCU will result in the IDE disconnecting from the target.

5.9. LED Supply (JP4)

The LED supply separates the LED power from the rest of the board. Disabling the LEDs removes their power consumption without having to modify firmware.

5.10. I2C Slave (H7)

The I2C Slave header provides ground, SDA, and SCL to enable connection to another board with an I2C master. A 4.7 kΩ pull-up is populated by default on both SDA and SCL.

5.11. External Clocks (U6, Y1, Y2)

The C8051F970 target board is equipped with a Silicon Labs Si504 programmable CMEMS oscillator and two crystal footprints Y1 and Y2. Y1 is a 25 MHz crystal that is populated by default. More information on the Si504 can be found on the Silicon Labs CMEMS website: www.silabs.com/cmems.

5.12. UART Connection Options (JP1-2, U5)

The target board features a USB virtual COM port (VCP) UART connection via the standard USB connector (J9). The VCP connection uses the CP210x USB-to-UART bridge chip (U5). The GPIO pins connected to the CP210x device can be enabled or disabled through the JP1 and JP2 headers. Table 2 shows the GPIO pins that are routed to the CP210x.

Table 2. CP210x Controlled GPIO Pins

MCU Pin	COM Function
P0.1	UART Transmit
P0.2	UART Receive

5.13. Port Pin Headers (H1-6)

All of the MCU port pins are available on the 0.100-inch headers on target board. Each connector provides connections to each port, VDD, and ground. Any unused pins on the **Port 5** header are not connected. Some of these port pins are shared with other functions on the board and may be modified as explained in Section 5.14.

C8051F970DK-UG

5.14. MCU Port Pin Connections

Table 3 summarizes all functions connected to each pin on the C8051F970 MCU in the target board.

Table 3. MCU Pin Functions

MCU Pin	Signal	
P0.0	VREF	Port Pin Header
P0.1	VCP_RX	Port Pin Header
P0.2	VCP_TX	Port Pin Header
P0.3	S1 switch	Port Pin Header
P0.4	S2 switch	Port Pin Header
P0.5	LED05	Port Pin Header
P0.6	RTC crystal	
P0.7	RTC crystal	
P1.0	External Oscillator (XTAL1)	Port Pin Header
P1.1	External Oscillator (XTAL2)	Port Pin Header
P1.2	LED12	Port Pin Header
P1.3	LED13	Port Pin Header
P1.4	LED14	Port Pin Header
P1.5	LED15	Port Pin Header
P1.6	LED16	Port Pin Header
P1.7	Si504 programming pin	Port Pin Header
P2.0	CS button	Port Pin Header
P2.1	CS button	Port Pin Header
P2.2	CS button	Port Pin Header
P2.3	CS button	Port Pin Header
P2.4	CS slider	Port Pin Header
P2.5	CS slider	Port Pin Header
P2.6	CS slider	Port Pin Header

MCU Pin	Signal	
P2.7	CS slider	Port Pin Header
P3.0	CS button	Port Pin Header
P3.1	CS button	Port Pin Header
P3.2	CS button	Port Pin Header
P3.3	CS button	Port Pin Header
P3.4	CS button	Port Pin Header
P3.5	CS button	Port Pin Header
P3.6	CS button	Port Pin Header
P3.7	CS button	Port Pin Header
P4.0	CS button	Port Pin Header
P4.1	CS button	Port Pin Header
P4.2	CS button	Port Pin Header
P4.3	CS button	Port Pin Header
P4.4	CS button	Port Pin Header
P4.5	CS button	Port Pin Header
P4.6	CS button	Port Pin Header
P4.7	CS button	Port Pin Header
P5.0	Potentiometer	Port Pin Header
P5.1		Port Pin Header
P5.2	C2D	Port Pin Header
P6.0	I2C Slave SCL	Port Pin Header
P6.1	I2C Slave SDA	Port Pin Header

5.15. Shorting Blocks: Factory Defaults

The C8051F970 target board comes from the factory with pre-installed shorting blocks on several headers. Figure 6 shows the positions of the factory default shorting blocks.

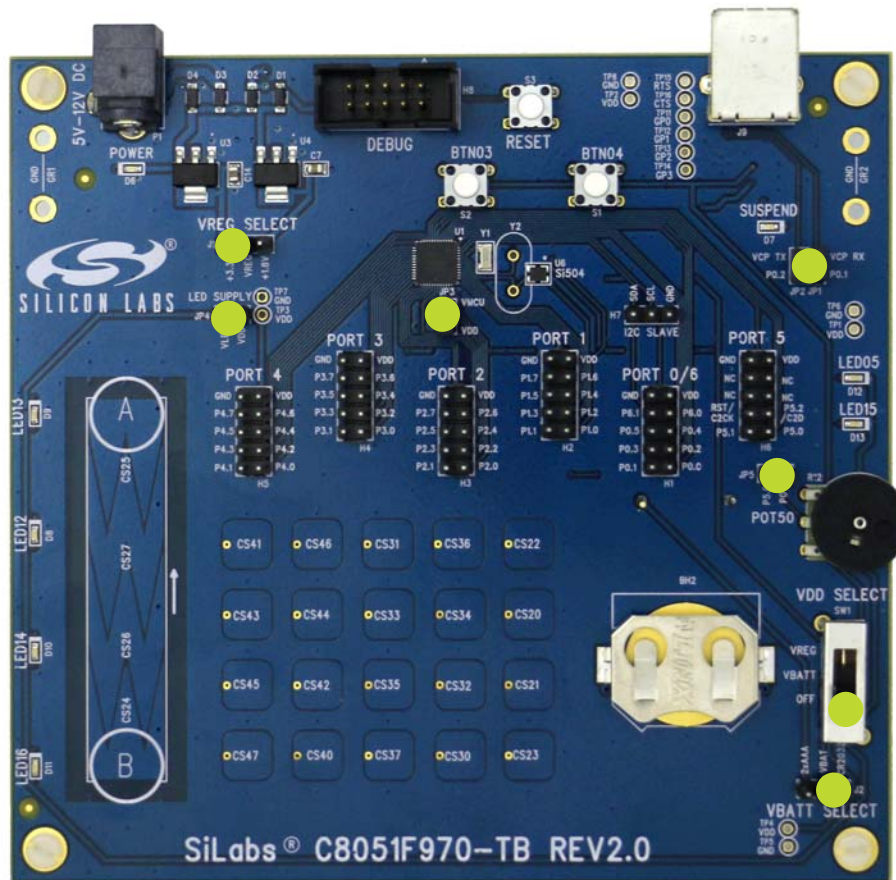

Figure 6. Shorting Blocks: Factory Defaults

By default, a shorting block is installed in the following locations:

- J1 (**VREG Select**): **+3.3V** connected to **VREG**
- J2 (**VBAT Select**): **CR2032** connected to **VBATT**
- JP1: P0.1 connected to **VCP_RX**
- JP2: P0.2 connected to **VCP_TX**
- JP3: VDD connected to **VDD_MCU**
- JP4: VDD connected to **VDD_LED**
- JP5: P5.0 connected to Potentiometer

In addition, the **VDD Select** switch is in the **OFF** position by default.

C8051F970DK-UG

6. Power Measurement

The C8051F970 MCU card includes a power measurement header JP3 for MCU power measurement purposes. The VDD_MCU supply on top of the header connects only to the MCU on the board. The VDD supply on the bottom of the JP3 header powers the external LEDs, switches, reset switch, potentiometer, and VCP COM port.

6.1. Measuring Power with Fixed VDD

To measure the power of the C8051F970 MCU using the target board at a fixed 3.3 V or 1.8 V:

1. Connect a USB Debug Adapter to the 10-pin shrouded debug connector (H8).
2. Remove the shorting blocks from the COM port pins (JP1 and JP2) and the potentiometer (JP5).
3. Remove the JP3 power measurement shorting block.
4. Connect a multimeter across (positive side on the bottom pin) the JP3 header.
5. Move the J1 shorting block to either the **+3.3V-VREG** or the **VREG→+1.8V** position.
6. Move the **VDD Select** switch (SW1) to the upper **VREG** position.
7. Connect the 9 V power adapter to **POWER** (P1).
8. Download the code to the board.
9. Measure the power of the device.

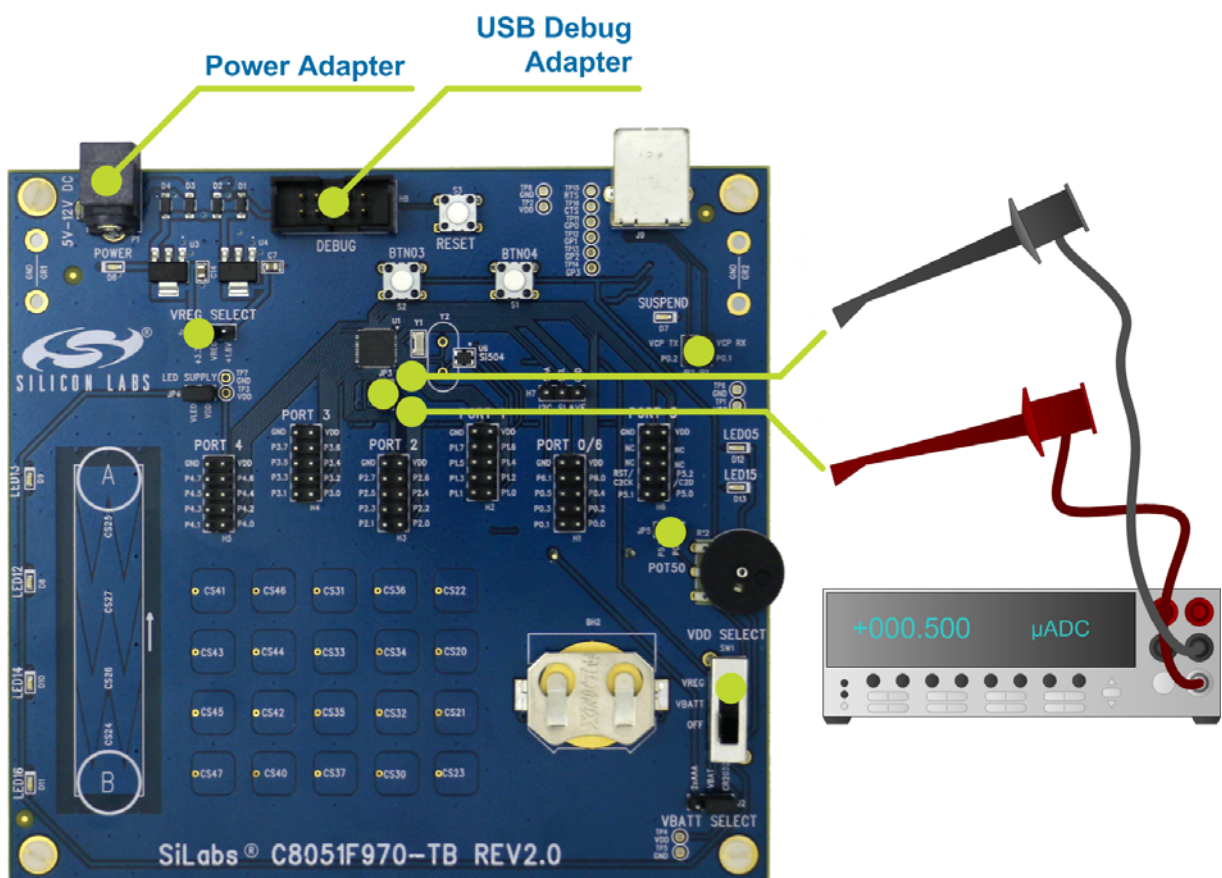

Figure 7. C8051F970 Power Measurement Configuration— Fixed VDD

6.2. Measuring Power with Varying VDD

To measure power with a varying VDD:

1. Connect a USB Debug Adapter to the 10-pin shrouded debug connector (H8).
2. Remove the shorting blocks from the COM port pins (JP1 and JP2) and the potentiometer (JP5).
3. Remove the JP3 power measurement shorting block.
4. Connect a multimeter across (positive side on the bottom pin) the JP3 header.
5. Remove the J1 shorting block.
6. Move the **VDD Select** switch (SW1) to the upper **VREG** position.
7. Connect a power supply to **VREG** on the J1 header (middle).
8. Download the code to the board.
9. Measure the power of the device.

Note: The pull-up resistor on /RST is powered by the VDD net, which is separated from the VDD_MCU net with the power measurement shorting block (JP3) removed. Powering the MCU using VDD_MCU without powering the VDD net may prevent Simplicity Studio from communicating with the MCU.

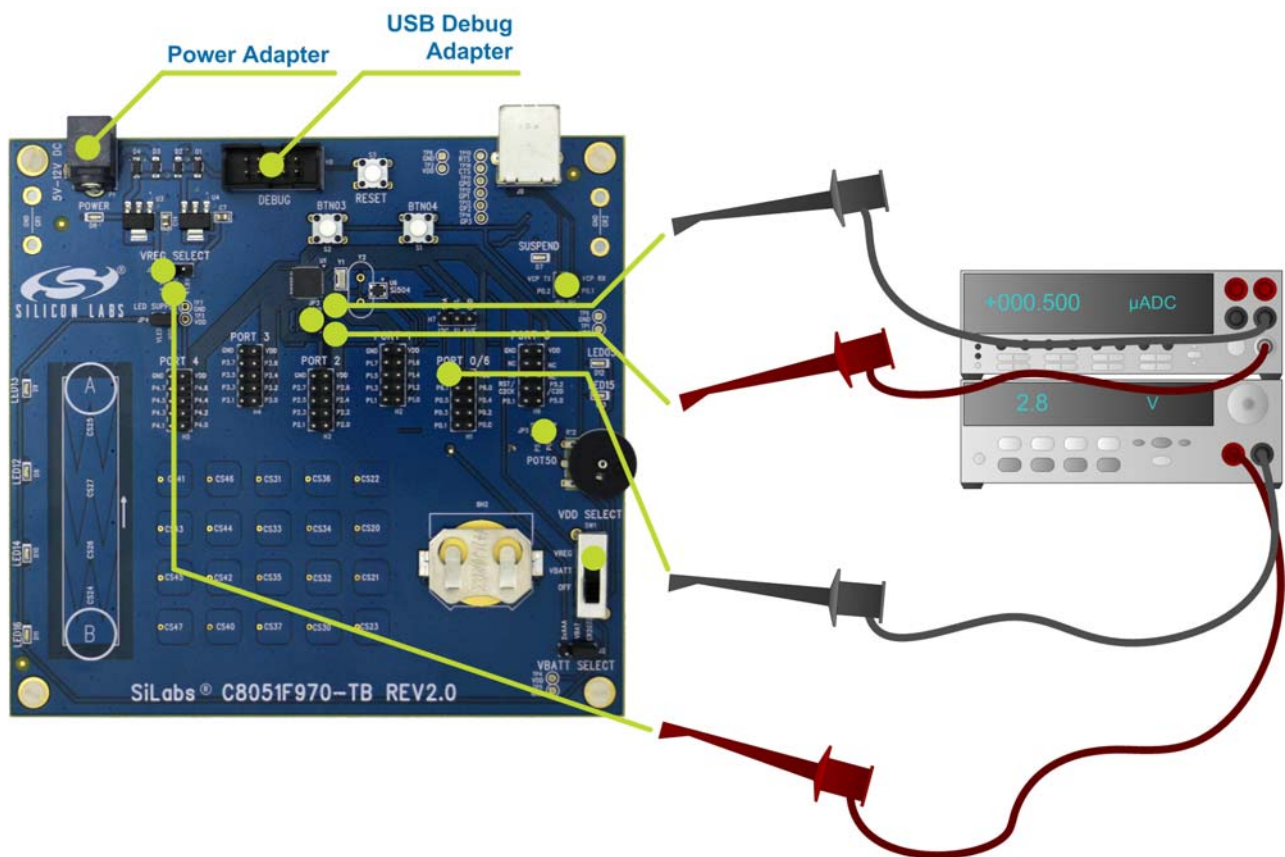

Figure 8. C8051F970 Power Measurement Configuration—Varying VDD

7. Known Board Issues

There are no known issues with Revision 2.0 of the C8051F970 target board.

8. Schematics

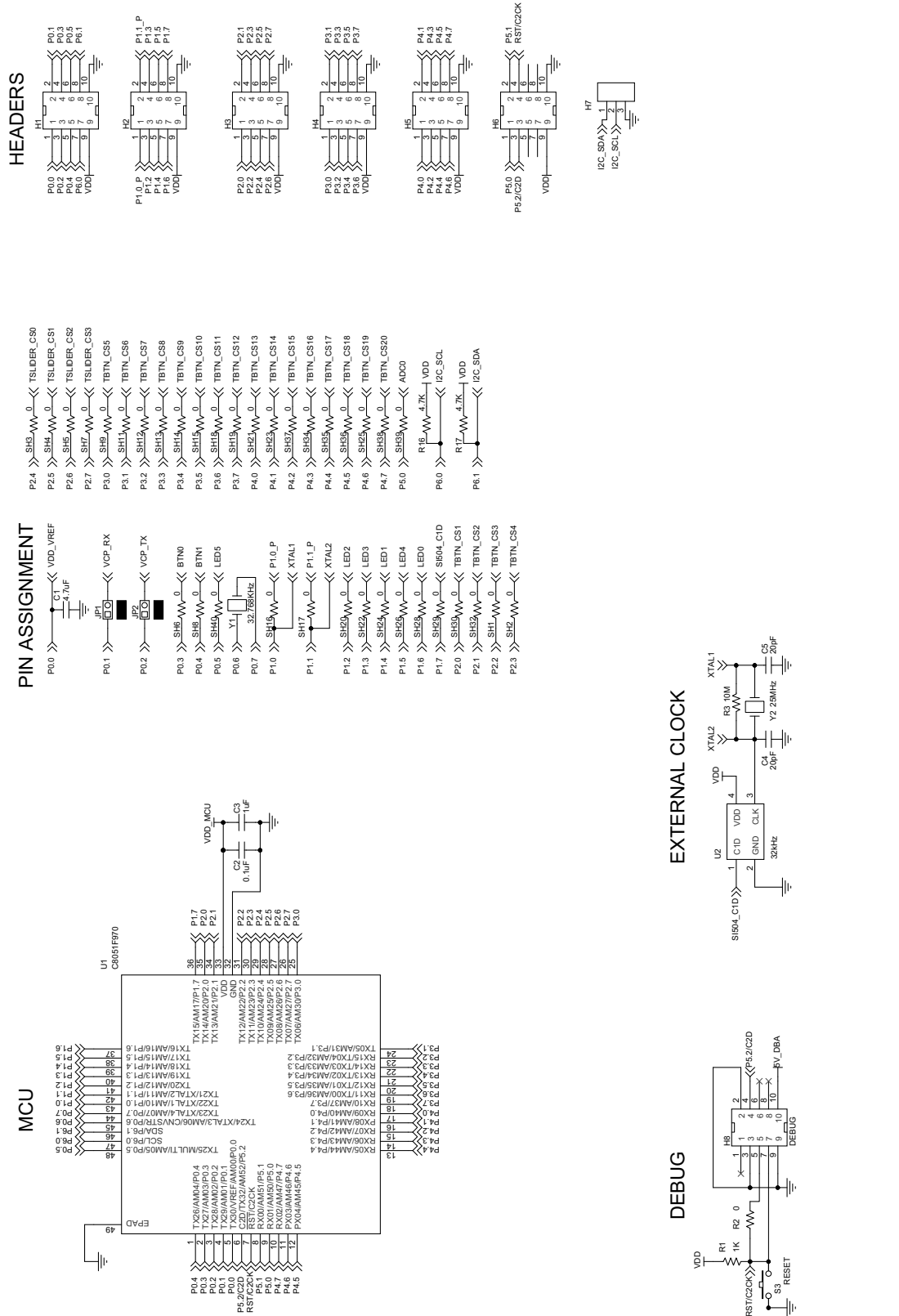

Figure 9. C8051F970 Target Board Schematic (Revision 2.0) (1 of 3)

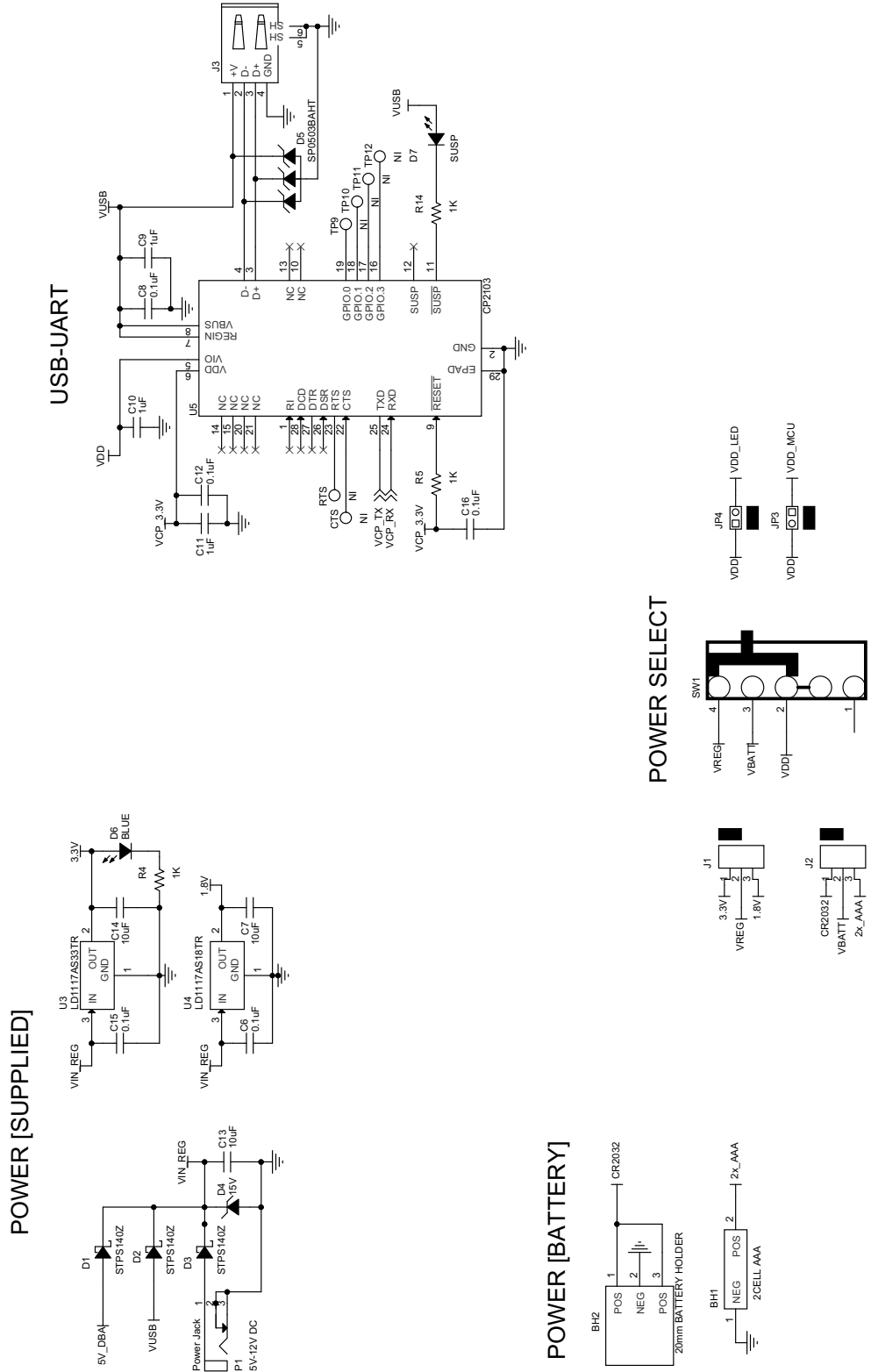
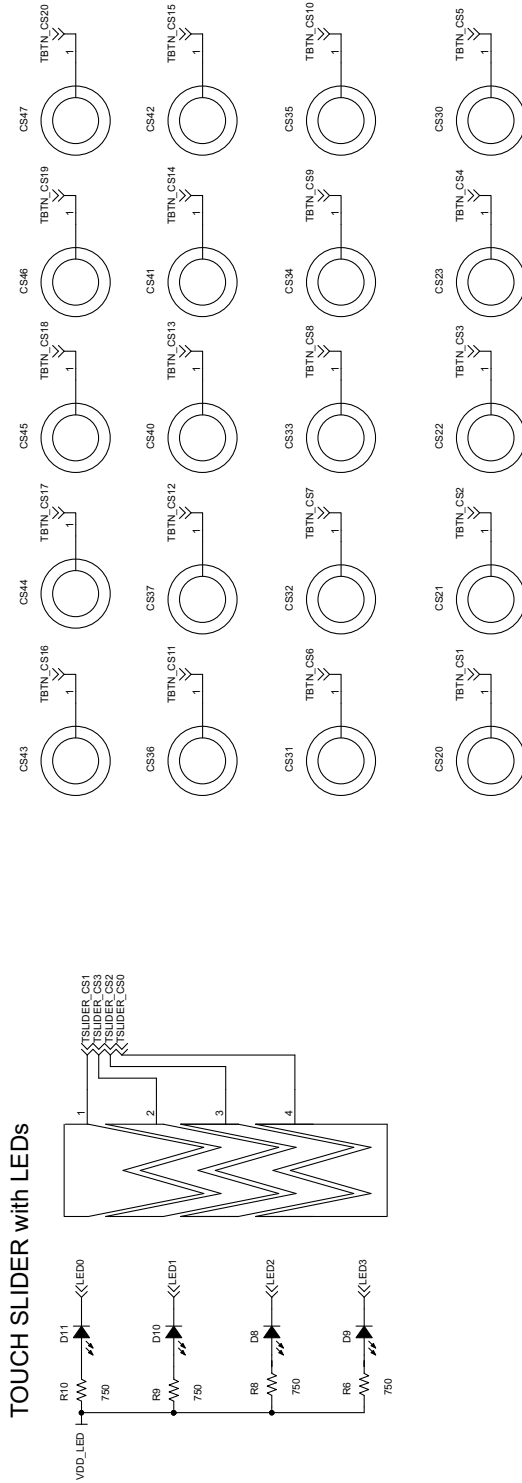
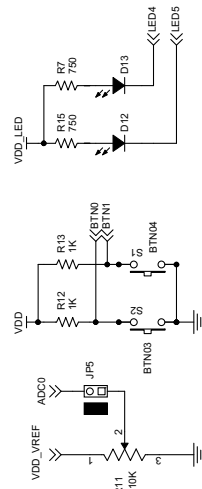

Figure 10. C8051F970 Target Board Schematic (Revision 2.0) (2 of 3)

TOUCH GRID



USER CONTROL



TESTPOINTS

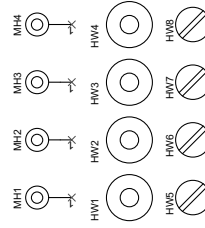
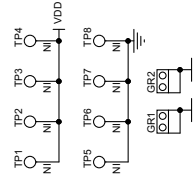

Figure 11. C8051F970 Target Board Schematic (Revision 2.0) (3 of 3)

9. Bill of Materials

Table 4. C8051F970 Target Board Bill of Materials

Reference	Part Number	Source	Description
BH1	2468	Keystone Electronics	2 cell AAA
BH2	BAT-HLD-001	Linx Technologies Inc.	20 mm CR2032 battery holder
C1	C0603X5R6R3-475K	Venkel	4.7 μ F, 6.3 V \pm 10% 0603
C2, C6, C8, C12, C15, C16	C0603X7R100-104K	Venkel	0.1 μ F, 10 V \pm 10% 0603
C3, C9, C10, C11	C0603X7R100-105K	Venkel	1 μ F, 10 V \pm 10% 0603
C7, C13, C14	C0805X5R160-106K	Venkel	10 μ F, 16 V \pm 10% 0805
D1, D2, D3	STPS140Z	ST Semiconductor	STPS140Z 1.0A 40V SOD-123
D4	MMSZ5245BT1	On Semi	15V 500mW 15V 5% SOD-123
D5	SP0503BAHTG	Littlefuse	USB ESD diodes 300mW 20V SOT143
D6, D7	LTST-C190TBKT	Lite-On Technology Corp.	Blue LED 0603
D8, D9, D10, D11, D12, D13	SML-LX0603IW	Lumex Inc.	Red 30 mA 0603
H1, H2, H3, H4, H5, H6	TSW-105-07-T-D	Samtec	5x2 header
H7, J1, J2	TSW-103-07-L-S	Samtec	1x3 header
H8	5103309-1	Tyco	5x2 Shrouded Header
HW1, HW2, HW3, HW4	1902D	Keystone Electronics	standoff
HW5, HW6, HW7, HW8	NSS-4-4-01	Richco Plastic Co	4-40 screws
J3	614 004 161 21	WURTH	USB TYPE B
JP1, JP2, JP3, JP4, JP5	TSW-102-07-T-S	Samtec	1x2 jumper
JS1, JS2, JS3, JS4, JS5, JS6, JS7	SNT-100-BK-T	Samtec	Jumper Shunt
P1	RAPC722X	Switchcraft Inc.	Power Jack 5A
R1, R4, R5, R12, R13, R14	CR0603-10W-1001F	Venkel	1 k Ω , 1/10 W \pm 1% 0603
R11	RV100F-30-4K1B-B10K-B301	Alpha (Taiwan)	10 k Ω , 0.03 W 30% 10 mm thumbwheel potentiometer
R16, R17	CR0603-10W-472J	Venkel	4.7 k Ω , 1/10W \pm 5% 0603

C8051F970DK-UG

Table 4. C8051F970 Target Board Bill of Materials (Continued)

Reference	Part Number	Source	Description
R2, SH1, SH2, SH3, SH4, SH5, SH6, SH7, SH8, SH9, SH11, SH12, SH13, SH14, SH15, SH16, SH17, SH18, SH19, SH20, SH21, SH22, SH23, SH24, SH25, SH26, SH28, SH29, SH30, SH32, SH34, SH35, SH36, SH37, SH28, SH29, SH30, SH32, SH34, SH35, SH36, SH37, SH38, SH39, SH40	CR0603-16W-000	Venkel	0 Ω , 1A 0603
R6, R7, R8, R9, R10, R15	CR0603-16W-7500F	Venkel	750 Ω , 1/10 W \pm 1% 0603
S1, S2, S3	EVQ-PAD04M	PANASONIC CORP	momentary switch
SW1	OS103012MU1QP1	C&K	3 position slide switch
U1	C8051F970-GM	Silicon Labs	C8051F970 QFN48
U2	504PCAA001033DAG	Silicon Labs	Programmable CMEMS Oscillator
U3	LD1117AS33TR	ST Semiconductor	3.3 V LDO SOT223
U4	LD1117AS18TR	ST Semiconductor	1.8 V 1A SOT223
U5	CP2103-GM	Silicon Labs	CP2103 USB to UART bridge (QFN28)
Y1	ABS07-32.768KHZ-7	Abracon Corporation	32.768 kHz crystal
Components Not Installed			
C4, C5	C0603C0G500-20K	Venkel	20 pF, 50 V \pm 10% 0603 (NI)
R3	CR0603-16W-1005F	Venkel	10 M Ω 1/16 W \pm 1% 0603 (NI)
TP1, TP2, TP3, TP4, TP5, TP6, TP7, TP8, TP9, TP10, TP11, TP12, TP13, TP14	151-205-RC	Kobiconn	Testpoint (NI)
Y2	ECS-250-18-4X-F	ECS	25 MHz HC-49/US (NI)

CONTACT INFORMATION

Silicon Laboratories Inc.

400 West Cesar Chavez

Austin, TX 78701

Tel: 1+(512) 416-8500

Fax: 1+(512) 416-9669

Toll Free: 1+(877) 444-3032

Please visit the Silicon Labs Technical Support web page:

<https://www.silabs.com/support/pages/contacttechnicalsupport.aspx>

and register to submit a technical support request.

Patent Notice

Silicon Labs invests in research and development to help our customers differentiate in the market with innovative low-power, small size, analog-intensive mixed-signal solutions. Silicon Labs' extensive patent portfolio is a testament to our unique approach and world-class engineering team.

The information in this document is believed to be accurate in all respects at the time of publication but is subject to change without notice. Silicon Laboratories assumes no responsibility for errors and omissions, and disclaims responsibility for any consequences resulting from the use of information included herein. Additionally, Silicon Laboratories assumes no responsibility for the functioning of undescribed features or parameters. Silicon Laboratories reserves the right to make changes without further notice. Silicon Laboratories makes no warranty, representation or guarantee regarding the suitability of its products for any particular purpose, nor does Silicon Laboratories assume any liability arising out of the application or use of any product or circuit, and specifically disclaims any and all liability, including without limitation consequential or incidental damages. Silicon Laboratories products are not designed, intended, or authorized for use in applications intended to support or sustain life, or for any other application in which the failure of the Silicon Laboratories product could create a situation where personal injury or death may occur. Should Buyer purchase or use Silicon Laboratories products for any such unintended or unauthorized application, Buyer shall indemnify and hold Silicon Laboratories harmless against all claims and damages.

Silicon Laboratories and Silicon Labs are trademarks of Silicon Laboratories Inc.

Other products or brandnames mentioned herein are trademarks or registered trademarks of their respective holders.