

ANALOG PERIPHERALS

- **Two 16-bit ADC's**
 - Programmable Throughput up to 1Msps (each ADC)
 - ± 1.5 LSB INL; guaranteed no missing codes
 - Configurable as two Single-Ended or one Differential ADC
 - DMA to XRAM or External Memory Interface
 - Data Dependent Windowed Interrupt Generator
- **10-bit ADC**
 - Programmable Throughput up to 200ksps
 - 8 External Inputs
 - Built-in Temperature Sensor ($\pm 3^\circ\text{C}$)
- **Two 12-bit DACs**
 - Can Synchronize Outputs to Timers for Jitter-Free Waveform Generation
- **Three Comparators**
- **Internal Voltage Reference**
- **Precision VDD Monitor/Brown-out Detector**

ON-CHIP JTAG DEBUG & BOUNDARY SCAN

- On-Chip Debug Circuitry Facilitates Full Speed, Non-Intrusive In-System Debug (No Emulator Required!)
- Provides Breakpoints, Single Stepping, Watchpoints, Stack Monitor
- Inspect/Modify Memory and Registers
- Superior Performance to Emulation Systems Using ICE-Chips, Target Pods, and Sockets
- IEEE1149.1 Compliant Boundary Scan
- Low Cost, **Complete** Development Kit

100-Pin TQFP

Temperature Range: -40°C to $+85^\circ\text{C}$

HIGH SPEED 8051 μC CORE

- Pipelined Instruction Architecture; Executes 70% of Instructions in 1 or 2 System Clocks
- Up to 25MIPS Throughput with 25MHz System Clock
- Expanded Interrupt Handler

MEMORY

- 4352 Bytes Internal Data RAM (256 + 4k)
- 64k Bytes In-System Programmable FLASH Program Memory
- External 64k Byte Data Memory Interface

CAN Bus 2.0B

- 32 Message Objects
- "Mailbox" implementation only interrupts CPU when needed

DIGITAL PERIPHERALS

- 59 Port I/O; Port 0 is 5V tolerant
- Hardware SMBus™ (I2C™ Compatible), SPI™, and **Two** UART Serial Ports Available Concurrently
- Programmable 16-bit Counter Array with 6 Capture/Compare Modules
- Five General Purpose 16-bit Counter/Timers
- Dedicated Watch-Dog Timer; Bi-directional Reset

CLOCK SOURCES

- Internal Programmable 2% Oscillator: 24.5MHz
- External Oscillator: Crystal, RC, C, or Clock
- Real-Time Clock Mode using Timers or PCA

SUPPLY VOLTAGE 2.7V to 3.6V

- Multiple Power Saving Sleep and Shutdown Modes

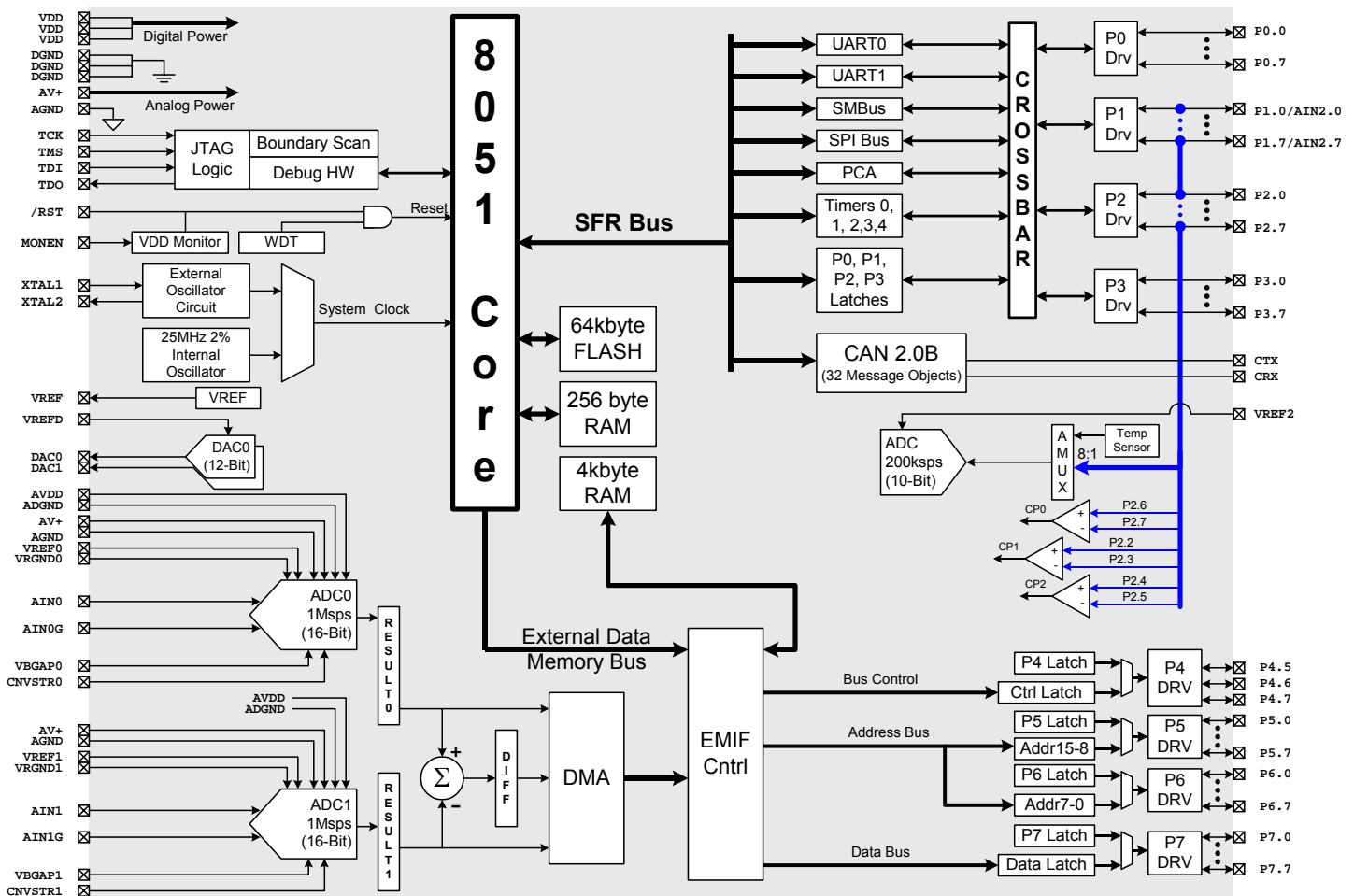



C8051F062 16-bit ADCs, CAN, 64KB FLASH, 100-Pin MCU

SILICON LABORATORIES

PRELIMINARY

SELECTED ELECTRICAL SPECIFICATIONS T_A = -40°C to +85°C, V_{DD} = 2.7V unless otherwise specified.

PARAMETER	CONDITIONS	MIN	TYP	MAX	UNITS
GLOBAL CHARACTERISTICS					
Supply Voltage		2.7		3.6	V
Supply Current (CPU active)	Clock=25MHz		18		mA
	Clock=1MHz		0.7		mA
	Clock=32kHz; VDD Monitor Enabled		20		μA
Supply Current (shutdown)	Oscillator not running; VDD Monitor Disabled		0.1		μA
Clock Frequency Range		DC		25	MHz
16-BIT A/D CONVERTERS					
Resolution			16		bits
Integral Nonlinearity	Single-ended Mode		± 1.5	± 4	LSB
	Differential Mode		± 1	± 2	LSB
Differential Nonlinearity	Guaranteed Monotonic		± 0.5	± 1	LSB
Signal-to-Noise Plus Distortion	Fin = 10kHz, Single-ended		86		dB
	Fin = 10kHz, Differential		89		dB
Total Harmonic Distortion	Fin = 10kHz, Single-ended		96		dB
	Fin = 10kHz, Differential		103		dB
Spurious-Free Dynamic Range	Fin = 10kHz, Single-ended		97		dB
	Fin = 10kHz, Differential		104		dB
Throughput Rate				1	Msp/s
Input Voltage Range	Single-ended (AINn – AINnG)	0		VREF	V
	Differential (AIN0-AIN1)	-VREF		VREF	V
Power Supply Current (each ADC)	Operating Mode, 1 Msps (AVDD + AV+)		5.5		mA
		Shutdown Mode	1		μA
	D/A CONVERTERS				
Resolution			12		LSB
Differential Nonlinearity				± 1	LSB
Output Settling Time			10		μs

PACKAGE INFORMATION

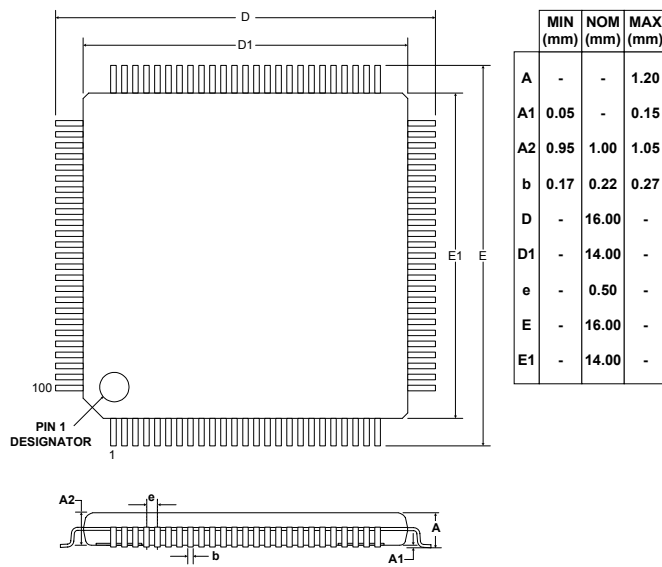

C8051F060DK DEVELOPMENT KIT

