



FEATURES OF MX10F201FC (80C51 with MTP memory and LCD)

- 80C51 CPU core
- 4.5 ~ 5.5V voltage range
- 2 to 16MHz clock frequency
- 16K bytes MTP memory for code memory
- 512 bytes internal data RAM
- Low power consumption
- Up to 16 digits LCD driver/controller
- Four 8 bit general purpose I/O ports
- Two standard 16-bit Timers
- On-chip Watch Dog Timer
- Two channel PWM outputs
- UART
- 8 interrupt sources
- 100 pin PQFP package
- Single clock or dual clock
- EMI compatibility

Features list

- 80C51 CPU core
- 4.5 ~ 5.5V operation voltage range
- 2 to 16MHz clock frequency
- 16K bytes MTP memory for code memory
 - More than 100 times program/erase cycles
 - More than 10 years data retention
- 512 bytes internal data RAM
- Low operation current
- Power saving modes
 - User friendly power control for active mode current
 - Idle mode
 - Sleep mode
 - Power down mode, can be wake up by external interrupts or RESET
- LCD driver/controller
 - Max. 16-digits display at 1/4 duty LCD
 - 1:1(static), 1:2, 1:3 or 1:4 selectable LCD multiplexing rate
 - 4 backplane driver, 32 segment driver
 - LCD directly drive capability with display memory
 - VLCD to control LCD driving voltage, (VLCD-VSS)
- 4x8 general purpose I/O ports
- Provide software I²C capability
- Two standard 16-bit Timers (Timer 0,1)
- On-chip Watch Dog Timer (WDT)
- Two channel PWM outputs
- UART
- Up to 8 interrupt sources and 8 interrupt vectors
 - 4 external sources
 - 4 internal sources(Timer0,Timer1,watch Timer and UART)
- 100 pin PQFP package
- Single clock or dual clock
 - single clock mode : 2~16MHz system clock for CPU,Timer0/1,WDT,UART and LCD
 - dual clock mode : 2~16MHz system clock for CPU,Timer0/1,WDT,UART; while 32.768KHz sub-system clock for LCD and watch timer.
 - system clock is either crystal or RC activated
- EMC(Electro-Magnetic Compatibility) improved

PINNING

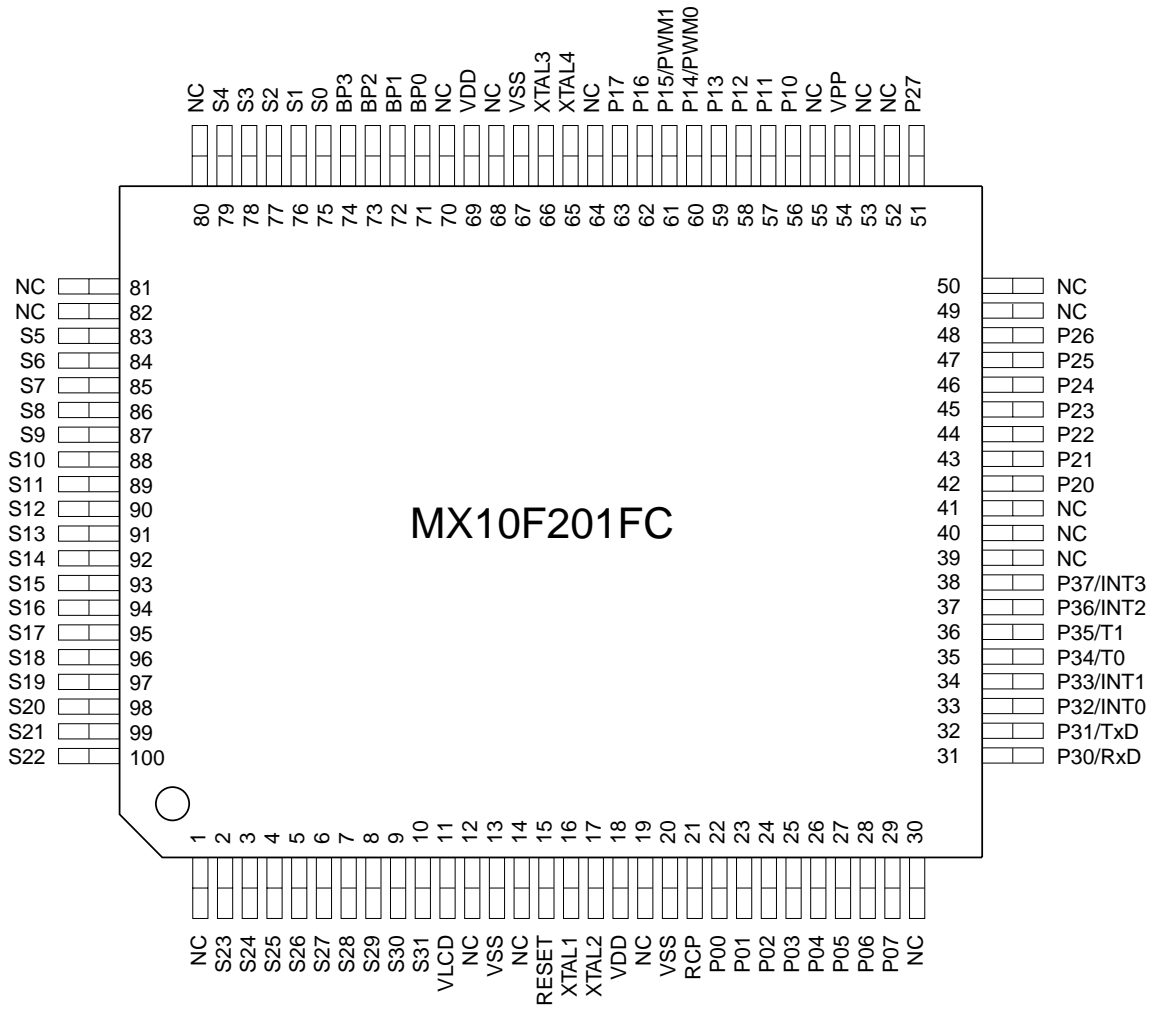

Fig.1 Pinning

Table. 1 Pin Description

I/O	SYMBOL	PIN \QFP 100	DESCRIPTION
O	BP0-BP3	71~74	Backplane drive output line 0 to 3.
O	S00-S31	75-79,83-100, 2-10	Segment drive output line 0 to 31.
I/O	P00-P07	22-29	Port:8-bit open drain bidirectional I/O Port
I/O	P20-P27	42-48,51	Port: 8-bit quasi-bidirectional I/O Port with internal pull-up
I/O	P10-P17 P14 P15	56-63	Quasi-bidirectional I/O lines also for PWM channel 0 also for PWM channel 1
I/O	P30-P37 P30 P31 P32-P33, P36-P37 P34 P35	31-38 31 32	Quasi-bidirectional I/O lines also for UART Receive also for UART Transmit also for external interrupt 0-3 also for Timer0 external input also for Timer1 external input
I	RESET	15	reset input
I	VDD	18,69	Positive power supply
I	VSS	13,20,67	Ground
I	XTAL1	16	XTAL connection input
O	XTAL2	17	XTAL connection output
I	XTAL3	66	32.768KHz, XTAL input
O	XTAL4	65	32.768KHz, XTAL output
I	RCP	21	RC oscillator resistor connection input
I	TEST/VPP	54	Supply 12V power for programming / erasing
I	VLCD	11	LCD driver power supply

Note:

1. To avoid a 'Latch-up' effect at power-on , the voltage on any pin (at any time)must not be higher than $V_{DD} + 0.5 V$ or lower $V_{SS} - 0.5V$ respectively
2. The generation or use of a Port 3 pin as an alternative function is carried out automatically by the associated Special Function Register (SFR) bit is properly written .

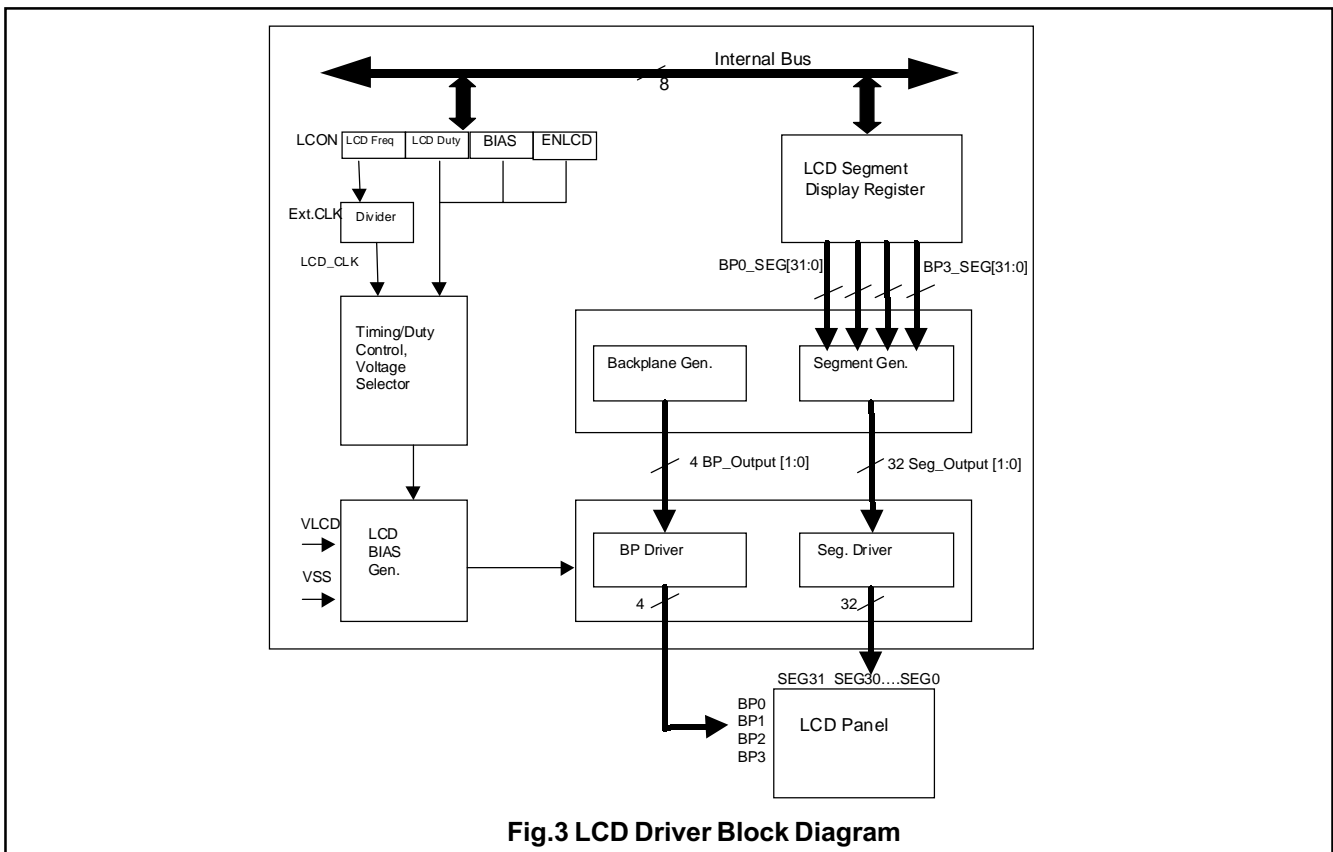
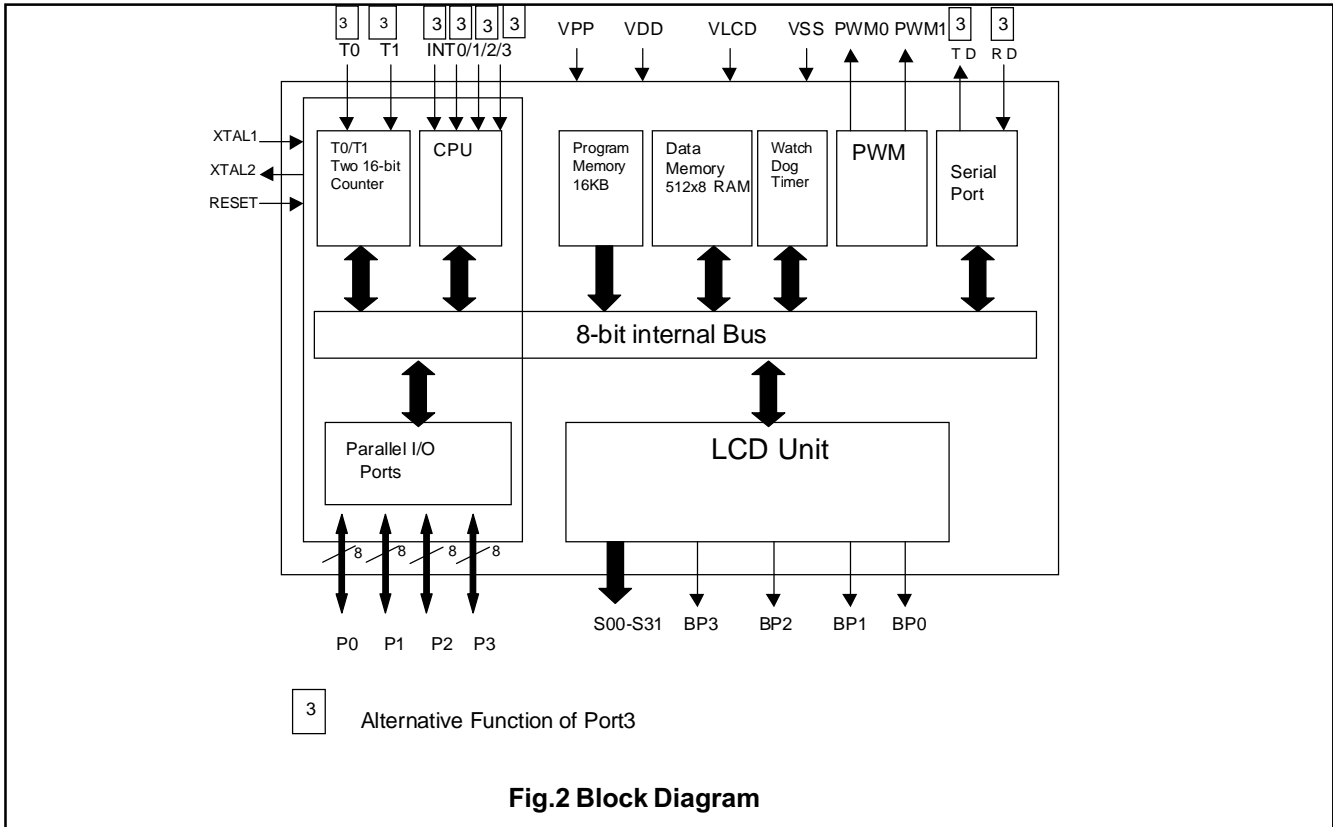

FUNCTIONAL DESCRIPTION

General

The MX10F201FC is a stand-alone high-performance and low power microcontroller designed for use in many applications which need code programmability.

The Flash EPROM offers customers to program the device themselves. This feature increases the flexibility in many applications, not only in development stage, but also in mass production stage.

In addition to the 80C51 standard functions, the MX10F201FC provides a number of dedicated hardware functions. MX10F201FC is a control-oriented CPU with on-chip program and data memory. It can execute program with internal memory up to 16k bytes. MX10F201FC has four software selectable modes of reduced activity for power reduction : active power control, idle, sleep, and Power-down. The idle mode freezes the CPU while allowing the RAM, Timers, serial ports, interrupt system and other peripherals to continue functioning. The Power-down mode saves the RAM contents but freezes the oscillator causing all other chip functions to be inoperative. Power-down mode can be terminated by an external reset ,and in addition , by either of the four external interrupts. The sleep mode behaves like power down mode, but with LCD and oscillator still turning on. And sleep mode can be terminated as the power down mode does.

Instruction Set Execution

The MX10F201FC uses the powerful instruction set of the 80C51. Additional SFRs are incorporated to control the on-chip peripherals. The instruction set consists of 49 single-byte, 46 two-bytes, and 16 three-bytes instructions. When using a 16MHz oscillator, 64 instructions execute in 750 ns and 45 instructions execute in 1.5 us. Multiply and divide instructions execute in 3 us.

MEMORY ORGANIZATION

The Central Processing Unit (CPU) manipulates operands in three memory spaces; these are the 256 bytes internal data memory (RAM), 256 byte auxiliary data memory (AUX-RAM) and 16k byte internal MTP program memory (FEPROM).

Program Memory

The program memory address space of the MX10F201FC comprises an internal and an external memory space. The MX10F201FC has 16k byte of program memory on-chip.

Program Protection

If the user choose to set security lock in MTP memory, the program content is protected from reading out of chip.

Internal Data Memory

The internal data memory is divided into three physically separated parts: 256 byte of RAM, 256 bytes of AUX-RAM, and 128 bytes special function register area (SFR). These parts can be addressed as follows (see Fig.4 and Table. 2)

- RAM 0 to 127 can be addressed directly and indirectly as in the 80C51. Address pointers are R0 and R1 of the selected register bank.
- RAM 128 to 255 can only be addressed indirectly . Address pointers are R0 and R1 of the selected register bank.
- AUX-RAM 0 to 255 is indirectly addressable as the external data memory locations 0 to 255 with the MOVX instructions. Address pointers are R0 and R1 of the selected register bank and DPTR. When executing from internal program memory, an access to AUX_RAM 0 to 255 will not affect the ports P0,P2,P3.6 and P3.7. SFRs can only be addressed directly in the address range from 128 to 255.

Table. 2 Internal data memory access

LOCATION	ADDRESSED
RAM 0 to 127	DIRECT and INDIRECT
RAM 128 to 255	INDIRECT only
AUX-RAM 0 to 255	INDIRECT only with MOVX
Special Function Register (SFR) 128 to 255	DIRECT only

Fig. 4 shows the internal memory address space. Table 3 shows the Special Function Register (SFR) memory map. Location 0 to 31 at the lower RAM area can be divided into four 8-bit register banks. Only one of these banks may be enabled at a time. The next 16 bytes, locations 32 through 47, contain 128 directly addressable bit locations.

The stack can be located anywhere in the internal 256 byte RAM. The stack depth is only limited by the available internal RAM space of 256 bytes. All registers except the Program Counter and the four 8-byte register banks reside in the SFR address space.

- Register
- Direct
- Register-Indirect
- Immediate
- Base-Register plus Index-Register-Indirect.

The first three methods can be used for addressing destination operands. Most instructions have a 'destination / source' field that specifies the data type, addressing methods and operands involved. For operations other than MOVs, the destination operand is also a source operand.

Access to memory addresses is as follows:

- Register in one of the four 8-byte register banks through Direct or Register-Indirect addressing.
- 256 bytes of internal RAM through Direct or Register-Indirect addressing. Bytes 0-127 of internal RAM may be only be addressed indirectly as data RAM.
- SFR through direct addressing at address location 128-255.

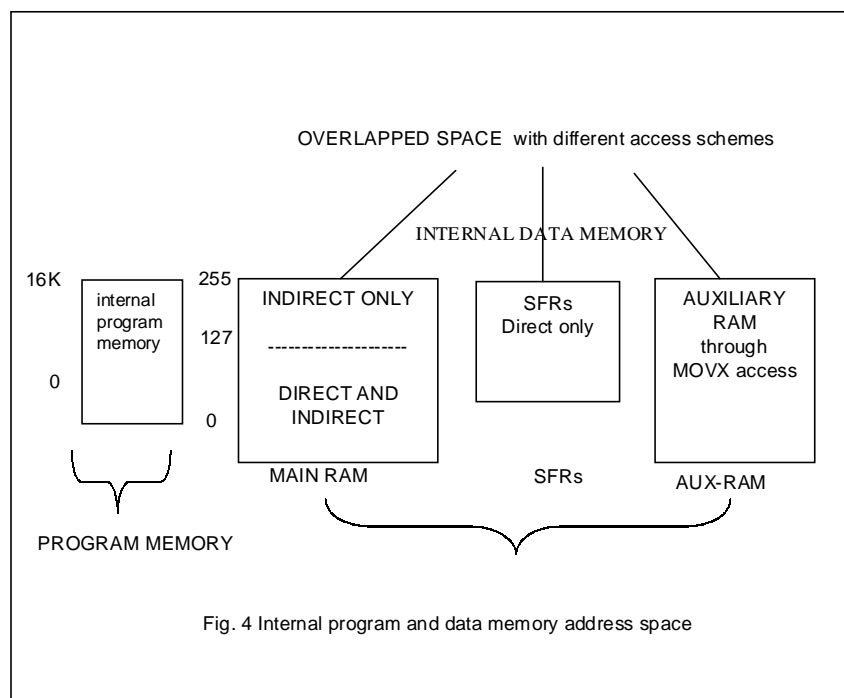



Table. 3 SFR Registers Map

Symbol	Direct Address(ex)	Reset Value
P0	80H	1111,1111
SP	81	0000,0111
DPL	82	0000,0000
DPH	83	0000,0000
PCON	87	0000,0000
TCON	88	0000,0000
TMOD	89	0000,0000
TL0	8A	0000,0000
TL1	8B	0000,0000
TH0	8C	0000,0000
TH1	8D	0000,0000
P1	90	1111,1111
SCON	98	0000,0000
SBUF	99	xxxx,xxxx
P2	A0	1111,1111
IE	A8	0000,0000
P3	B0	1111,1111
IP	B8	x000,0000
LCON	BA	x001,1100
LCD0	BB	0000,0000
LCD1	BC	0000,0000
LCD2	BD	0000,0000
LCD3	BE	0000,0000
LCD4	BF	0000,0000
INTCON	C0	0000,0000
LCD5	C1	0000,0000
LCD6	C2	0000,0000
LCD7	C3	0000,0000
LCD8	C4	0000,0000
LCD9	C5	0000,0000
LCDA	C6	0000,0000
LCDB	C7	0000,0000
PSW	D0	0000,0000
LCDC	D1	0000,0000
LCDD	D2	0000,0000
LCDE	D3	0000,0000
LCDF	D4	0000,0000
ACC	E0	0000,0000
WTL	E3	0000,0000
WTH	E4	xx00,0000
IEN1	E8	xxxx,xx00
EBTCON	EB	xxxx,001x
B	F0	0000,0000
PCON1	F1	x000,0100
IP1	F8	xxxx,xx00
PWM0	FC	0000,0000
PWM1	FD	0000,0000
PWMP	FE	0000,0000
T3 (WDT)	FF	1111,1111

I/O facilities

MX10F201FC has one 8 bits port, port 0, which is open drain, and three 8 bits ports, port 1/2/3, which are quasi bi-directional ports. These four ports are fully compatible to standard 80C51's port 0/1/2/3.

- Port1: pins can be configured individually to provide 2 PWM outputs.
- Port3: pins can be configured individually to provide: external interrupt inputs (external interrupt 0/1/2/3); external inputs for Timer/ counter 0 and Timer /counter1, and UART receive / transmit.

Port pins which are not used for alternate functions may be used as normal bidirectional I/O pins. The generation or use of a Port 1 or Port 3 pin as an alternate function is carried out automatically by writing the associated SFR bit with proper value.

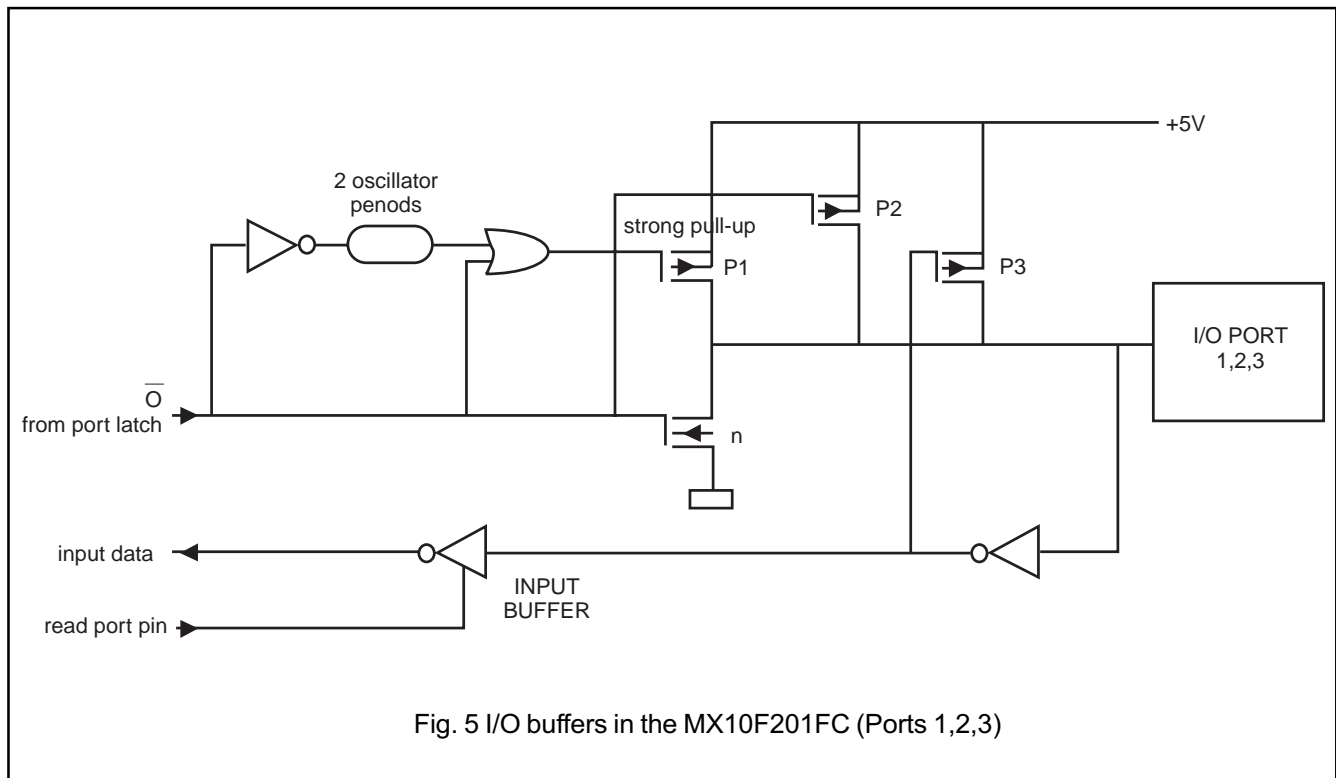

Timer/Counter

MX10F201FC's Timer/Counter 0 and 1 are fully compatible to standard 80C51's.

The MX10F201FC's contains two 16-bit Timer/counters, Timer 0 and Timer 1. Timer 0 and Timer 1 may be programmed to carry out the following functions:

- measure time intervals and pulse durations
- count events
- generate interrupt requests.

Timer 0 and Timer 1

Timers 0 and 1 each have a control bit in TMOD SFR that selects the Timer or counter function of the corresponding Timer. In the Timer function, the register is incremented every machine cycle. Thus, one can think of it as counting machine cycles. Since a machine cycle consists of 12 oscillator periods, the count rate is 1/12 of the oscillator frequency.

In the counter function, the register is incremented in response to a HIGH-to-LOW transition at the corresponding samples, when the transition shows a HIGH in one cycle and a LOW in the next cycle, the counter is incremented. Thus, it takes two machine cycles (24 oscillator periods) to recognize a HIGH-to-LOW transition. There are no restrictions on the duty cycle of the external input signal, but to ensure that a given level is sampled at least once before it changes, it should be held for at least one full machine cycle.

Timer 0 and Timer 1 can be programmed independently to operate in one of four modes (refer to table 5) :

- Mode 0 : 8-bit Timer/counter with divided-by-32 prescaler
- Mode 1 : 16-bit Timer/counter
- Mode 2 : 8-bit Timer/counter with automatic reload
- Mode 3 : Timer 0 :one 8-bit Timer/counter and one 8-bits Timer. Timer 1 :stopped.

When Timer 0 is in Mode 3, Timer 1 can be programmed to operate in Modes 0, 1 or 2 but cannot set an interrupt request flag and generate an interrupt. However, the overflow from Timer 1 can be used to pulse the Serial Port transmission-rgate generator. With a 16 MHz crystal, the counting frequency of these Timer/counters is as follows:

- in the Timer function, the Timer is incremented at a frequency of 1.33 MHz (oscillator frequency divided by 12).
- in the counter function, the frequency handling range for external inputs is 0 Hz to 0.66 MHz (oscillator frequency divided by 24).

Both internal and external inputs can be gated to the Timer by a second external source for directly measuring pulse duration.

The Timers are started and stopped under software control. Each one sets its interrupt request flag when it overflows from all logic 1's to all logic 0's (respectively, the automatic reload value), with the exception of Mode 3 as previously described.

TMOD : TIMER/COUNTER MODE CONTROL REGISTER

This register is located at address 89H.

Table. 4 TMOD SFR (89H)

7	6	5	4	3	2	1	0
GATE	C/ T	M1	M0	GATE	C/ T	M1	M0
(MSB)				(LSB)			
TIMER 1				TIMER 0			

keep the above table with the following table

Table. 5 Description of TMOD bits

MNEMONIC	POSITION	FUNCTION
TIMER 1		
GATE	TMOD.7	Timer 1 gating control : when set, Timer/counter '1' is enabled only while 'Int1' pin is high and 'tr1' control bit is set. when cleared, Timer/counter '1' is enabled whenever 'tr1' control bit is set.
C/T	TMOD.6	Timer or counter selector: cleared for Timer operation (input from internal system clock). set for counter operation (input from 'T1' input pin).
M1	TMOD.5	Operation mode: see table 6.
M0	TMOD.4	Operation mode: see table 6.
TIMER 0		
GATE	TMOD.3	Timer 0 gating control: when set, Timer/Counter '0' is enabled only while 'Int0' pin is high and 'tr0' control bit is set. when cleared, Timer/counter '0' is enabled whenever 'tr0' control bit is set.
C/T	TMOD.2	Timer or counter selector: cleared for Timer operation (input from internal system clock). set for counter operation (input from 'T0' input pin).
M1	TMOD.1	Operation mode: see table 6.
M0	TMOD.0	Operation mode: see table 6.

Table. 6 TMOD M1 and M0 operating modes

M1	M0	FUNCTION
0	0	8-bit Timer/counter : 'THx' with 5-bit prescaler.
0	1	16-bit Timer/counter : 'THx' and 'TLx' are cascaded, there is no prescaler.
1	0	8-bit autoloader Timer/counter : 'THx' holds a value which is to be reloaded into 'TLx' each time it overflows.
1	1	Timer 0: TL0 is an 8-bit Timer/counter controlled by the standard Timer 0 control bits. TH0 is an 8-bit Timer controlled by Timer 1 control bits.
1	1	Timer 1 : Timer/counter 1 stopped.

TCON : TIMER/COUNTER CONTROL REGISTER

This register is located at address 88H.

Table. 7 TCON SFR (88H)

7	6	5	4	3	2	1	0
TF1	TR1	TF0	TR0	IE1	IT1	IE0	IT0
(MSB)						(LSB)	

keep the above table with the following table

Table. 8 Description of TCON bits

MNEMONIC	POSITION	FUNCTION
TF1	TCON.7	Timer 1 overflow flag : set by hardware on Timer/Counter overflow. Cleared when interrupt is processed.
TR1	TCON.6	Timer 0 overflow flag : set by hardware on Timer/Counter overflow. Cleared when interrupt is processed.
TF0	TCON.5	Timer 0 overflow flag: set by hardware on Timer/Counter overflow. Cleared when interrupt is processed.
TR0	TCON.4	Timer 0 control bit : set/cleared by software to turn Timer/counter ON/OFF.
IE1	TCON.3	Interrupt 1 edge flag: set by hardware when external interrupt is detected. Cleared when interrupt is processed.
IT1	TCON.2	Interrupt 1 type control bit : set/cleared by software to specify falling edge/LOW level triggered external interrupt.
IE0	TOCN.1	Interrupt 0 edge flag: set by hardware when external interrupt is detected. Cleared when interrupt is processed.
IT0	TOCN.0	Interrupt 0 type control bit: set/cleared by software to specify falling edge/LOW level triggered external interrupt.

Interrupt system

The MX10F201FC contains a 8-source 4 external interrupts, Timer 0, Timer1, watch timer and UART structures with two priority levels.

Each External interrupts INT0, INT1, INT2, and INT3 can be either level-activated or transition-activated depending on bits IT0 and IT1 in TCON SFR and IT2, IT3 in INTCON SFR. The flags that actually generate these interrupts are bits IE0, IE1 in TCON and IE2, IE3 in INTCON. When an external interrupt is generated, the corresponding request flag is cleared by the hardware when the service routine is vectored to, if the interrupt is transition-activated. If the interrupt is level-activated the external source has to hold the request active until the requested interrupt is actually generated. Then it has to deactivate the request before the interrupt service routine is completed, otherwise another interrupt will be generated.

The Timer 0 and Timer 1 Interrupts are generated by TF0 and TF1, which are set by a rollover in their respective Timer/counter register (except for Timer 0 in Mode 3 of the serial interface). When a Timer interrupt is generated, the flag that generated it is cleared by the on-chip hardware when the service routine is vectored to.

IE : INTERRUPT ENABLE REGISTER
This register is located at address A8H.

Table. 9 IE SFR (A8H)

7	6	5	4	3	2	1	0
EA	EX3	EX2	ES	ET1	EX1	ET0	EX0
(MSB)						(LSB)	

keep the above table with the following table

Table. 10 Description of IE bits

MNEMONIC	POSITION	FUNCTION
EA	IE.7	Disable all interrupt - Low, all disabled. - High, each interrupt source is individually enabled or disabled by setting or clearing its enable bit.
EX3	IE.6	Enable / Disable External interrupt 3. - Low, disabled - High, enabled
EX2	IE.5	Enable / Disable External Interrupt 2. - Low, disabled - High, enabled
ES	IE.4	Enable / Disable UART interrupt. - Low, disabled - High, enabled
ET1	IE.3	Enable / Disable Timer1 overflow interrupt.
EX1	IE.2	Enable / Disable External interrupt 1. - Low, disabled - High, enabled
ET0	IE.1	Enable / disable Timer0 overflow interrupt.
EX0	IE.0	Enable / Disable External interrupt 0. - Low, disabled - High, enabled

IEN1 : INTERRUPT ENABLE REGISTER 2

Table. 11 IEN1 SFR (E8H)

7	6	5	4	3	2	1	0
-	-	-	-	-	-	EWT	0

EWT : Enable / Disable Watch Timer interrupt.

IP : INTERRUPT PRIORITY REGISTER

This register is located at address B8H.

Table. 12 IP SFR (B8H)

7	6	5	4	3	2	1	0
-	PX3	PX2	PS	PT1	PX1	PT0	PX0 (LSB)

keep the above table with the following table

Table. 13 Description of IP bits

MNEMONIC	POSITION	FUNCTION
-	IP.7	RESERVED
PX3	IP.6	Define External interrupt 3 interrupt priority level. - High, assign a high priority level.
PX2	IP.5	Define External interrupt 2 interrupt priority level. - High, assign a high priority level.
PS1	IP.4	Define interrupt priority level of UART.
PT1	IP.3	Define Timer1 overflow interrupt priority level.
PX1	IP.2	Define External interrupt 1 interrupt priority level. - High, assign a high priority level.
PT0	IP.1	Define Timer0 overflow interrupt priority level.
PX0	IP.0	Define External interrupt 0 interrupt priority level. - High, assign a high priority level.

IP1 : INTERRUPT PRIORITY REGISTER 2

Table. 14 IP1 SFR (F8H)

7	6	5	4	3	2	1	0
-	-	-	-	-	-	PWT	0

PWT : Define Watch Timer interrupt priority level.

Table. 15 INTCON SFR (C0H)

7	6	5	4	3	2	1	0
0	0	WTF	WTR	IE3	IT3	IE2	IT2

Table. 16 Description of INTCON bits

IE3/2 : External interrupt 3/2 edge flag. Set by H/W when external interrupt is detected, and cleared when interrupt is processed.

IT3/2 : External interrupt 3/2 type control bit. Set/cleared by S/W to specify falling edge/low level triggered external interrupt.

WTF : Watch timer overflow interrupt flag. Set by H/W when watch timer overflow occurred, and cleared by S/W or warm/cold reset.

WTR : Watch timer enable bit. Set/ cleared by S/W

Table. 17 INTERRUPT VECTORS & PRIORITY WITHIN LEVELS

source	name	Priority Within Level	Vector Address
Ext. interrupt0	IE0	1(Highest)	0003H
Timer0 overflow	TF0	2	000BH
Ext. interrupt1	IE1	3	0013H
Timer1 overflow	TF1	4	001BH
UART interrupt	IS	5	0023H
Ext. interrupt2	IE2	6	002BH
Ext. interrupt3	IE3	7	0033H
Watch timer overflow	WTF	8	003BH

Watch Timer

The watch timer module (see Fig. 6) is clocked by 32.768KHz external crystal, and generates interrupt request every 0.5 second. This value is derived from $f_{\text{timer}} = f_{\text{osc}} / (256 \times 64)$. The watch timer consists of an 8-bit timer register WTL and a 6-bit timer registers WTH. The WTL register is triggered by the 32.768KHz external crystal, and the WTH register increases its value while WTL overflow occurs. When the overflow of WTH occurs, the WTF bit in SFR INTCON is set High automatically and an interrupt request is sent to the microcontroller.

Both of the timer registers WTL and WTH can be loaded values by software. Therefore the time interval of the watch timer interrupt request can be adjusted. This allows the watch timer to send interrupt request more frequently for some special application.

The WTF can be set both by hardware and software, but it can only be cleared by software. The 32.768KHz external oscillator is gated by the WTR bit in SFR INTCON. If WTR is cleared, the watch timer registers will hold their values.

In the idle and sleep states the watch timer remains active, and it wakes up the microcontroller while the watch timer overflow (i.e. WTF is set HIGH) occurs.

Since this module is clocked by the 32.768KHz external crystal, this module is disabled and consumes no power if there is no such crystal connected to the chip.

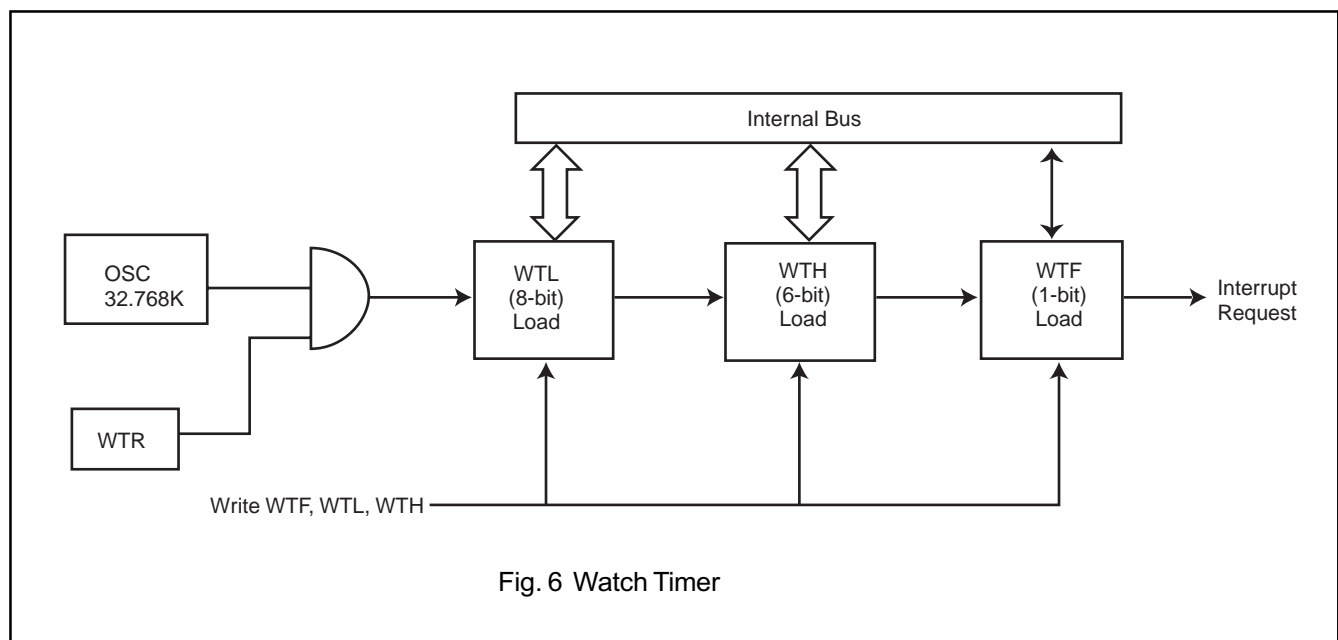

LCD drivers

The LCD module includes 4 by 32 pixel memory and can drive directly 4 backplanes and 32 segments outputs. Thus, for common digit-typed LCD, MX10F201FC can have maximum 16 digits display.

LCD Control Register (LCON)

Since MX10F201FC has several possible clocking alternatives : 2 to 16MHz system clock with possible second 32.768KHz sub-system clock, programmers need to set up this register to get proper LCD frame scan rate.

Table. 18 LCON SFR (BAH)

7	6	5	4	3	2	1	0
-	LCDF2	LCDF1	LCDF0	MD1	MD0	Bias	ENLCD

. LCDF2,LCDF1,LCDF0: Selection of LCD frame scan frequency

Table. 19

Fclk (ext. clk)	Divider Select	Frame scan freq (Hz)			
		1/4 Duty	1/3 Duty	1/2 Duty	Static
- 000 : 16Mhz	Fclk/2 ¹⁸	61	81	61	61
- 001 : 12Mhz	Fclk/(2 ¹⁶ *3)	61	81	61	61
- 010 : 8Mhz	Fclk/2 ¹⁷	61	81	61	61
- 011 : 4Mhz	Fclk/2 ¹⁶	61	81	61	61
- 100 : 2Mhz	Fclk/2 ¹⁵	61	81	61	61
- 101 : 1Mhz	Fclk/2 ¹⁴	61	81	61	61
- 110 :0.5Mhz	Fclk/2 ¹³	61	81	61	61
* - 111 : 32Khz	Fclk/2 ⁹	64	85	64	64

* Note : Dual clock mode is set by writing as "111".

. MD1,MD0: Mode bits, determine the LCD multiplex rate.

Table. 20

	No of Backplanes	Pixel	Digits
- 00 : static	1 (BP0)	32	4
- 01 : 1:2	2 (BP0,1)	64	8
- 10 : 1:3	3 (BP0,1,2)	96	12
- 11 : 1:4	4 (BP0,1,2,3)	128	16

. Bias: set LCD voltage bias generator.

- High, bias is 1/2(VLCD-VSS)
- Low, bias is 1/3(VLCD-VSS)

Table. 21

LCD Drive Mode	No of BPs	LCD Bias	Voff(rms)	Von(rms)	Contrast
static	1	static	0	1	infinity
1:2	2	1/2	0.354	0.791	2.236
1:2	2	1/3	0.333	0.745	2.236
1:3	3	1/3	0.333	0.638	1.915
1:4	4	1/3	0.333	0.577	1.732

. ENLCD: Enable/Disable LCD

- Low, all segment and backplanes drivers are set to the Vss level.
- High, the LCD is enable and digits display is possible.

LCD segment display register : contain the on/off information of 4 by 32 segments of LCD

Table. 22

Register	Address	Bit7	Bit6	Bit5	Bit4	Bit3	Bit2	Bit1	Bit0
LCD0	BBH			SEG1				SEG0	
LCD1	BCH			SEG3				SEG2	
LCD2	BDH			SEG5				SEG4	
LCD3	BEH			SEG7				SEG6	
LCD4	BFH			SEG9				SEG8	
LCD5	C1H			SEG11				SEG10	
LCD6	C2H			SEG13				SEG12	
LCD7	C3H			SEG15				SEG14	
LCD8	C4H			SEG17				SEG16	
LCD9	C5H			SEG19				SEG18	
LCDA	C6H			SEG21				SEG20	
LCDB	C7H			SEG23				SEG22	
LCDC	D1H			SEG25				SEG24	
LCDD	D2H			SEG27				SEG26	
LCDE	D3H			SEG29				SEG28	
LCDF	D4H			SEG31				SEG30	
		BP3	BP2	BP1	BP0	BP3	BP2	BP1	BP0

LCD drive mode waveform : used to control the voltage level of backplane and segment outputs

- . Static drive mode
- . 1:2 multiplex drive mode with 1/2 bias
- . 1:2 multiplex drive mode with 1/3 bias
- . 1:3 multiplex drive mode with 1/3 bias
- . 1:4 multiplex drive mode with 1/3 bias

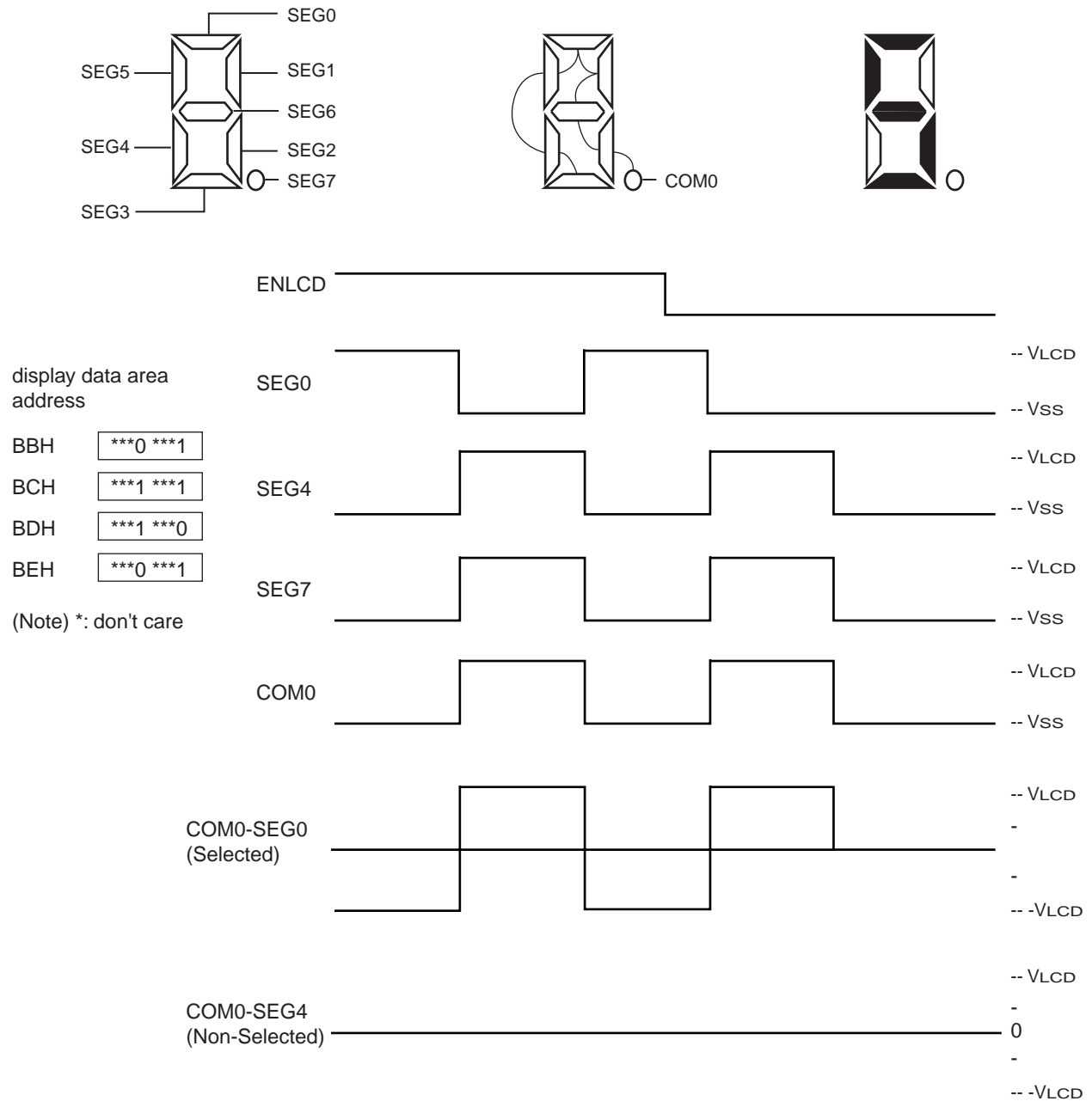

Fig. 7 Static Drive

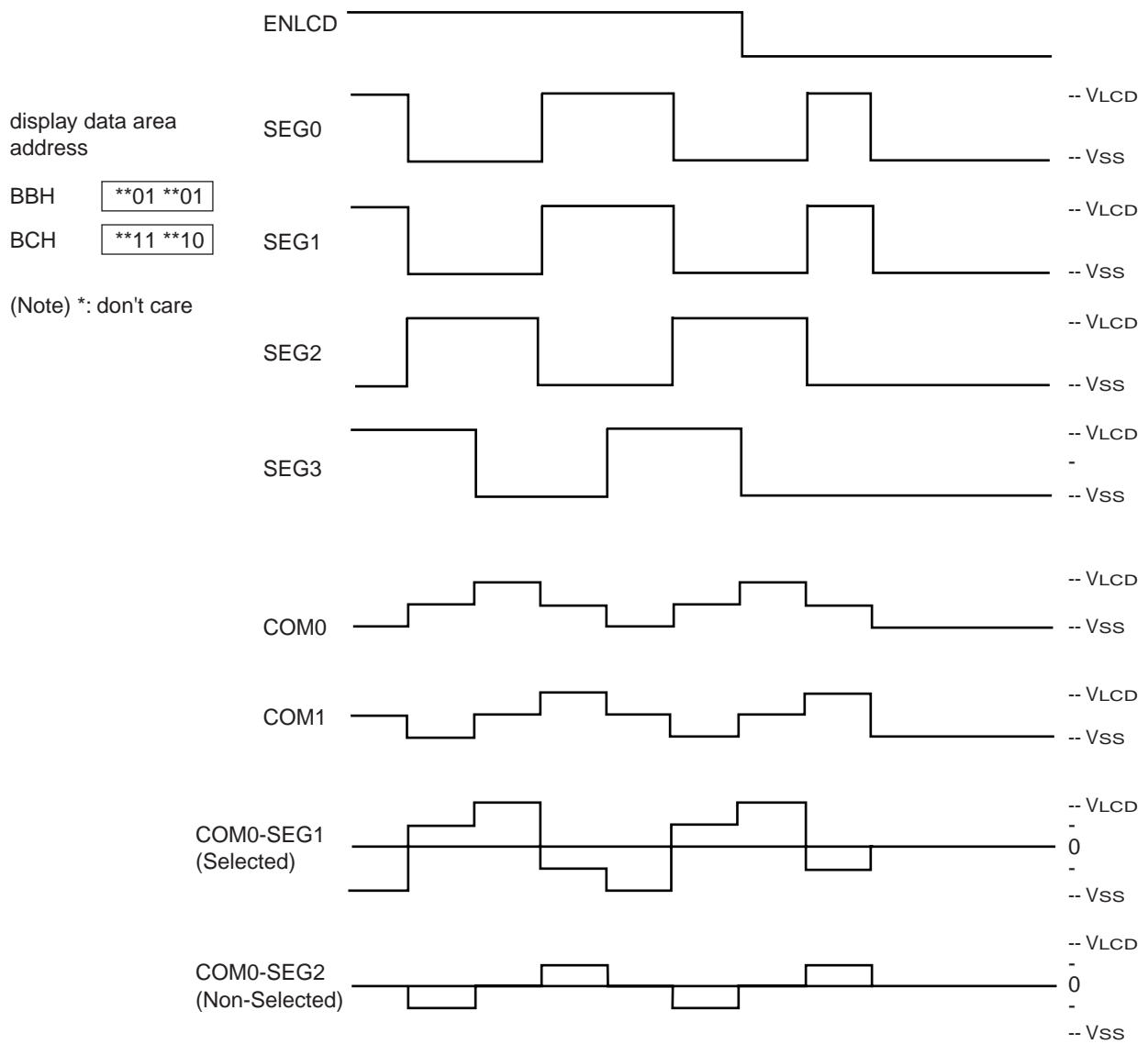
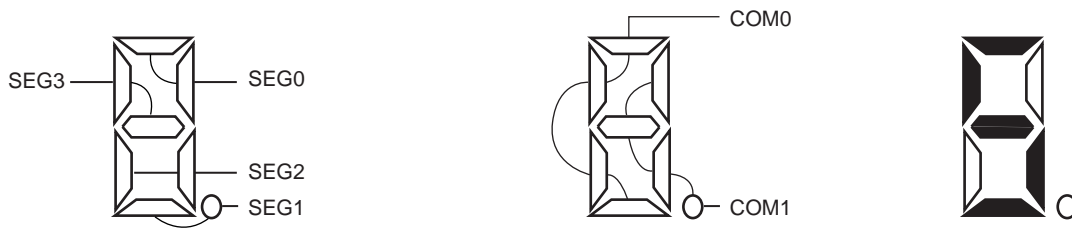

Fig. 8 1/2 Duty (1/2 Bias) Drive

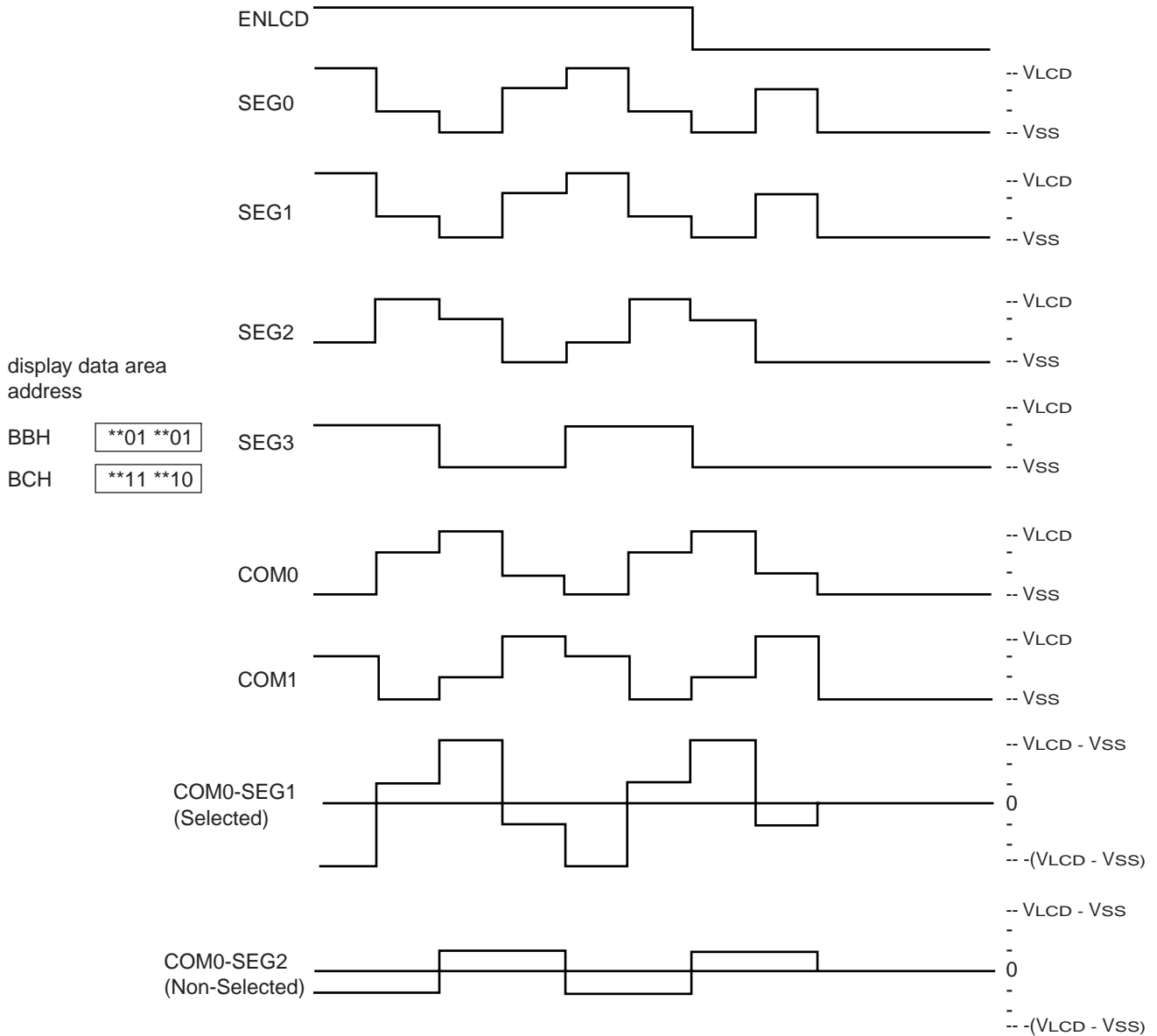
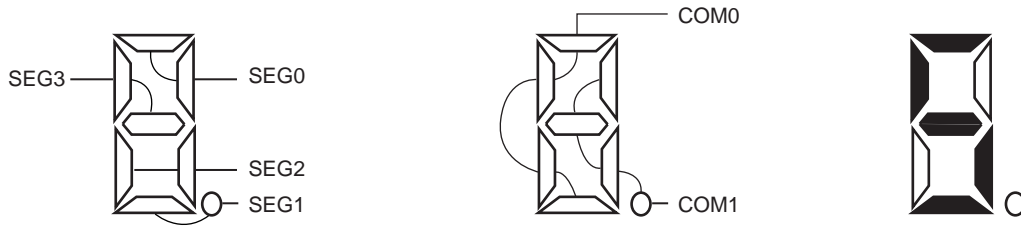
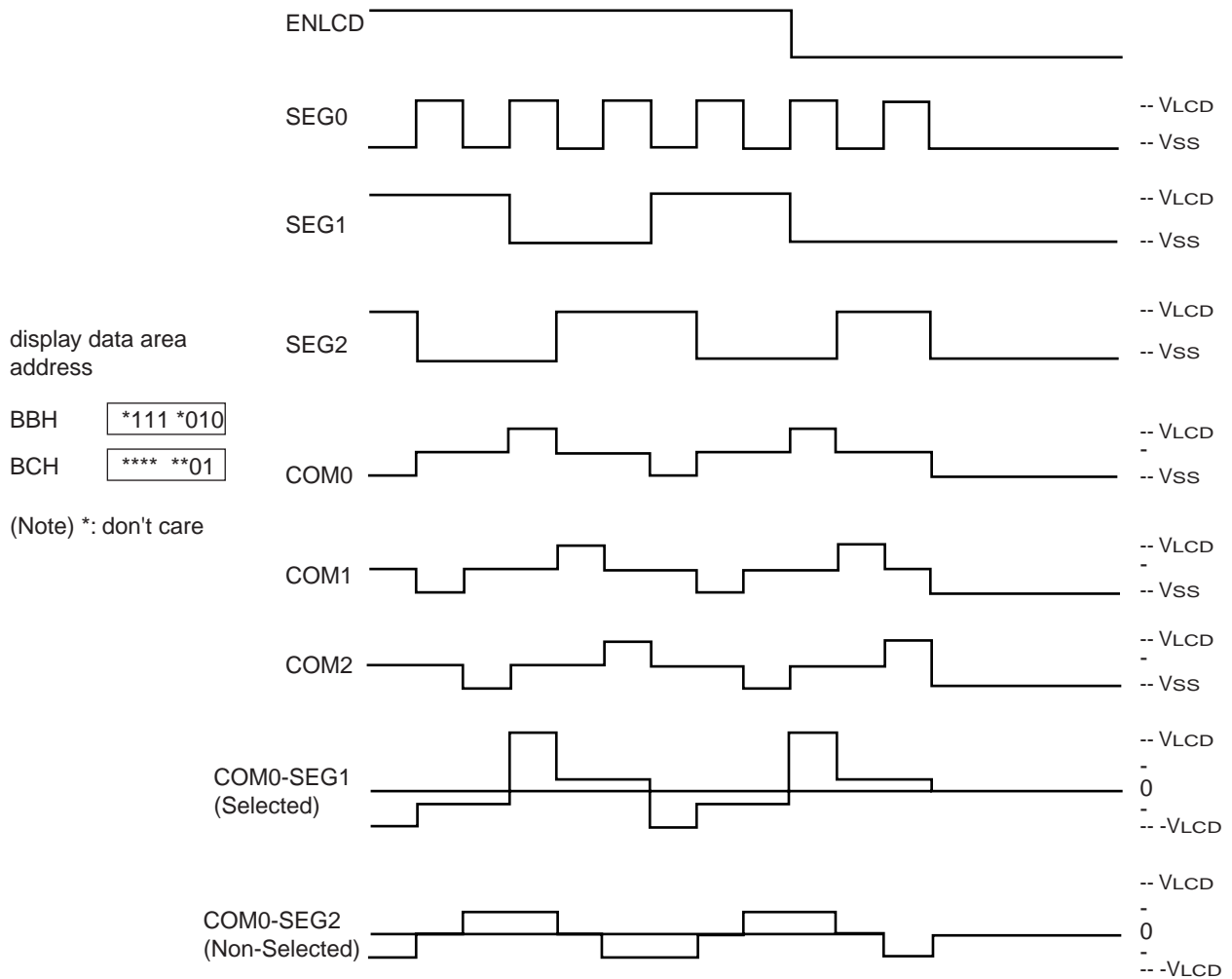
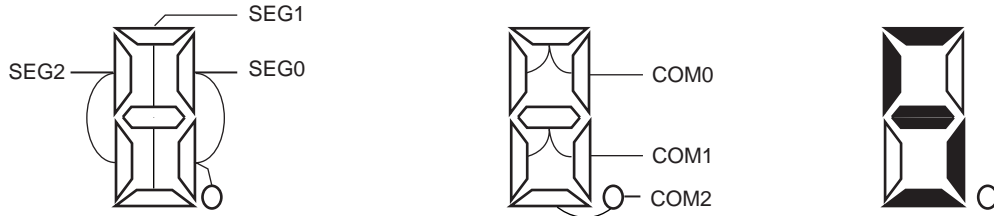

Fig. 9 1/2 Duty (1/3 Bias) Drive



(Note) *: don't care

Fig. 10 1/3 Duty (1/2 Bias) Drive

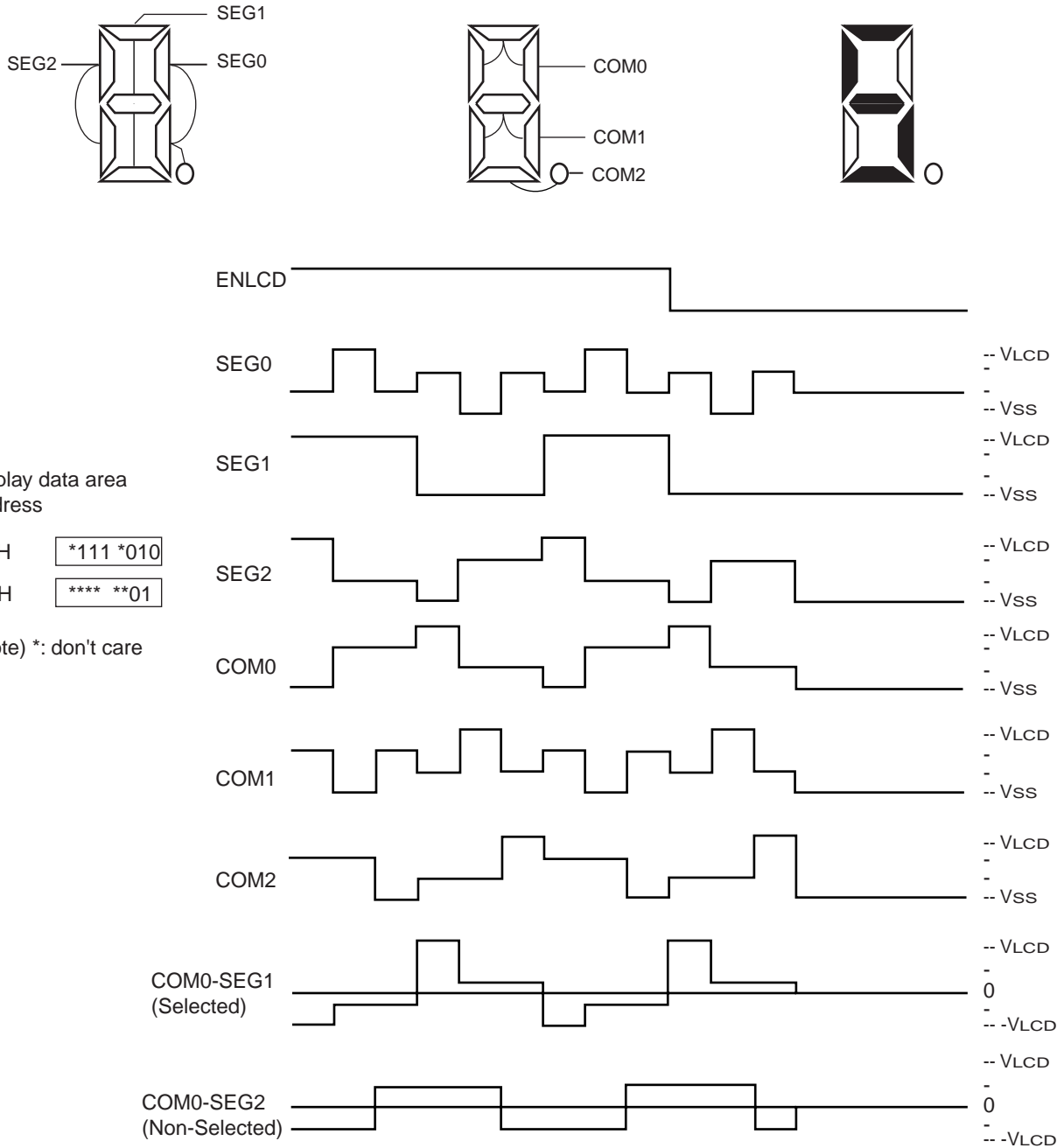

Fig. 11 1/3 Duty (1/3 Bias) Drive

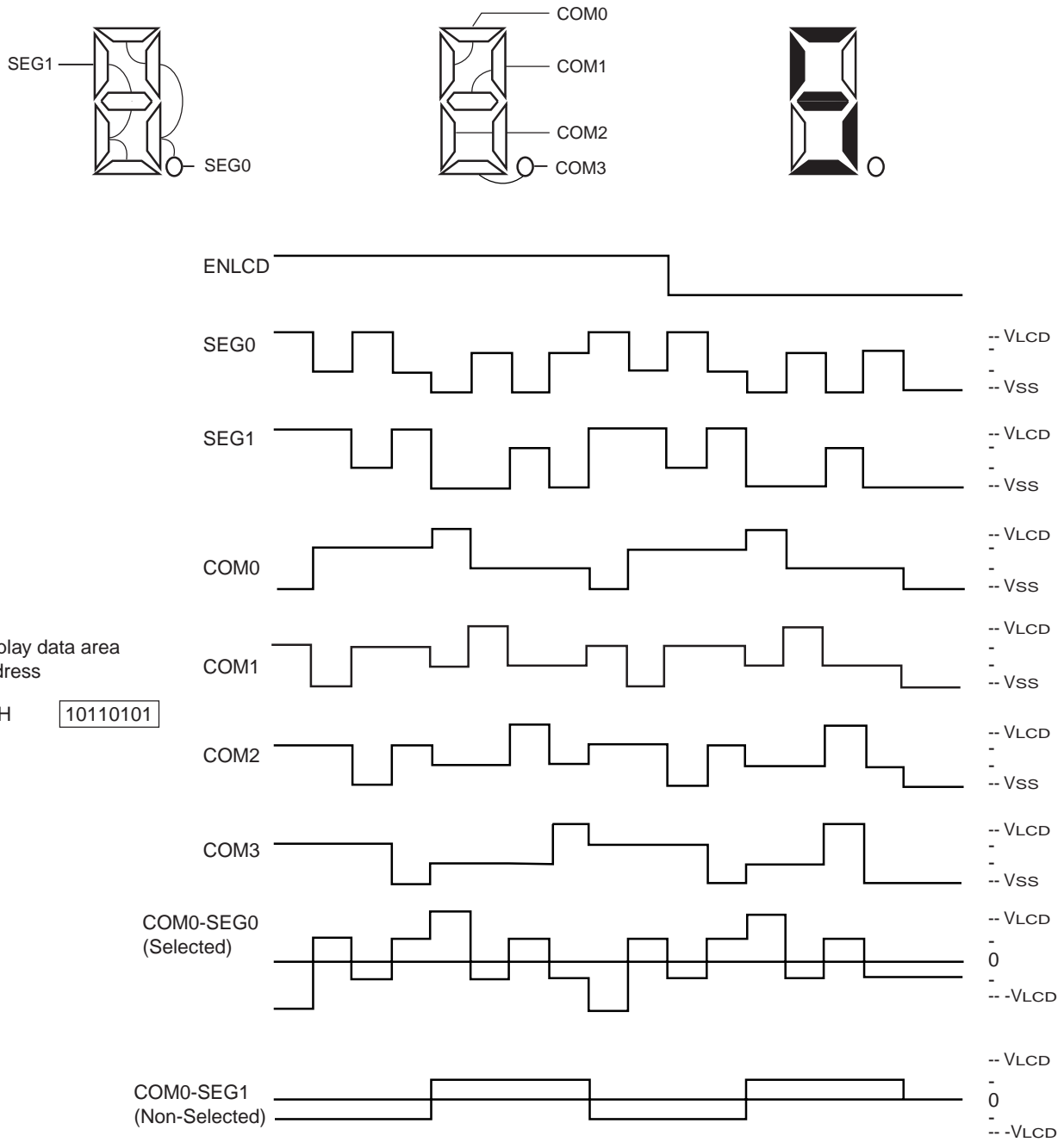

Fig .12 1/4 Duty (1/3 Bias) Drive

Power saving modes : active power control, idle, sleep and power down modes

In order to enable lowest power consumption in system application, MX10F201FC has user friendly power control mechanism as follows :

- 1) Active power control : used to turn off un-used peripherals in specific applications. For instance, UART might not be used in audio CD application, then programmer can disable it to save power.
- 2) Idle mode : used to turn off 80C51 during certain conditions.
- 3) Sleep mode : used to turn off the whole system except LCD and possibly watch Timer.
- 4) Power down mode : turn off the whole system.

PCON : Power Control Register (PCON)
PCON SFR (87H)

7	6	5	4	3	2	1	0
SMOD	-	SCEER	WLE	CF1	CF0	PD	IDC

SMOD : Doubl band rate bit for UART.

SLEEP : Sleep mode bit. Setting it activates sleep mode, and could be terminated as the way to terminate the pull down mode.

WLE : Watch dog load enable. This flag must be set prior to loading WDT and is cleaned when WDT is loaded.

CF1/CF0 : general-prepose flag bit.

PD : Power - down bit. Setting it activates power - down mode.

IDL : idle mode bit. Setting it activates idle mode.

Active power control mode

PCON1 : POWER CONTROL REGISTER 2

Table. 23 PCON1 SFR (F1H)

7	6	5	4	3	2	1	0
-	TD	UARTD	WDTD	PWMD	1	WTD	LCDD

Table. 24 Description of PCON1 bits

- . TD : Timer0/1 Disable bit. Setting it to shut-down Timer0/1.
- . UARTD: UART Disable bit. Setting it to shut-down UART.
- . WDTD : WatchDog Timer Disable bit. Setting it to shut-down WDT.
- . PWMD : Pulse Width Modulation Disable bit. Setting it to shut-down PWM.
- . WTD : Watch Timer Disable bit, Setting it to shu-down W T.
- . BIT 2 must write "1"
- . LCDD : LCD Disable bit. Setting it to shut-down all LCD relative modules.

RC oscillator function

MX10F201FC provides a RC oscillator function for the application that does not need very accurate system clock frequency and has to save the cost of crystal oscillator. As shown in Fig. 13, to use the RC oscillator function as the system clock source, a suggested 50K~200K can be connected between the RCP pin and ground. The XTAL1 pin has to be connected to ground or the internal clock system may be failed. When the system clock source comes from the crystal oscillator, the RCP pin is suggested to connect to VDD. The following table shows approximately the relationship between the RC oscillator clock frequency and the resistor value.

Table. 25 RC oscillator reference table

Resistor Value (K ohm)	RC oscillator clock frequency (MHz)	
	5V	3V
50	12~14	9~11
75	10~12	7.5~9
100	9~10	6.5~8
125	8~9	6~7.5
150	~7.5	5.5~6.5
175	~6.5	5.2~5.8
200	~6	4.7~5.3

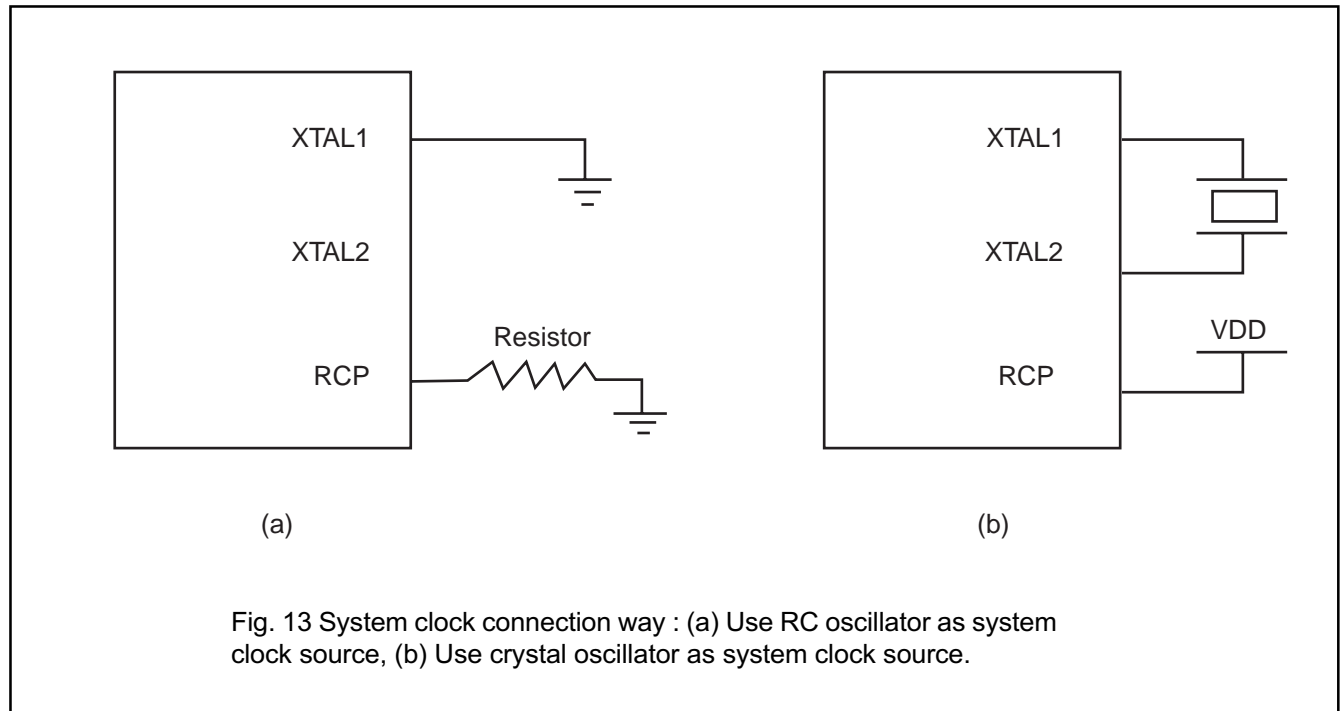

Clock system

MX10F201FC has two possible clocking schemes with four combinations as follows :

	System clock	Sub-system clock
Single clock mode	External 2 ~ 16MHz crystal (XTAL1,XTAL2)	XTAL3 is connected to GND
	RC oscillator with external resister (RCP) and XTAC1 is connected to GND	XTAL3 is connected to GND
Dual clock mode	External 2 ~ 16MHz crystal (XTAL1,XTAL2)	32.768KHzcrystal (XTAL3,XTAL4)
	RC oscillator with external resister (RCP) and XTAC1 is connected to GND	32.768KHz crystal (XTAL3,XTAL4)

The interaction between power saving modes and clock system is listed as follows :

	Single clock	Dual clock
80C51	System clock	System clock
Timer0/1, WDT, UART	System clock	System clock
LCD	System clock	Sub-system clock
Active mode	All are active except watch Timer	All are active
Power control active mode	Individual peripheral is disabled by corresponding active power control bit	Individual peripheral is disabled by corresponding active power control bit
Idle mode	1) 80C51 is stopped 2) can be wake up by any interrupt	1) 80C51 is stopped 2) can be wake up by any interrupt
Sleep mode	1) All are stopped except LCD, system oscillator. 2) can be wake up by external interrupts,	1) All are stopped except watch Timer, LCD, sub-system oscillator. 2) can be wake up by external interrupts,watch Timer or RESET
Power down mode	1)All are stopped 2) can be wake up by external interrupts or RESET	1) All are stopped 2) can be wake up by external interrupts or RESET

Watchdog Timer

The Watchdog Timer (WDT) see Fig.14 , consists of an 11-bit prescaler and an 8-bit Timer formed by SFR T3. The Timer is incremented every 1.5 ms, derived from the system clock frequency of 16 MHz by the following formula : $f_{Timer} = f_{clk} / (12 \times (2048))$. The 8-bit Timer increments every 12 x 2048 cycles of the on-chip oscillator. When a Timer overflow occurs, the microcontroller is reset. The internal RESET signal is not inhibited when the external RST pin is kept 0 into high impedance, no matter if the XTAL-clock is running or not.

To prevent a system reset the Timer must be reloaded in time by the application software. If the processor suffers a hardware / software malfunction, the software will fail to reload the Timer. This failure will result in an overflow thus prevent the processor from running out of control. This time interval is determined by the 8-bit reload value that is written into register T3.

Watchdog time interval = $[T3] \times 12 \times 2048 / \text{oscillator frequency}$

The watch-dog Timer can only be reloaded if the condition flag WLE (SFR PCON bit 4) has been previously set high by software. At the moment the counter is loaded WLE is automatically cleared.

In the idle state the watchdog Timer and reset circuitry remain active.

The watchdog Timer is controlled by the watchdog enable signal EW (SFR EBTCON bit 1). A LOW level enables the watchdog Timer. A HIGH level disable the watchdog Timer.

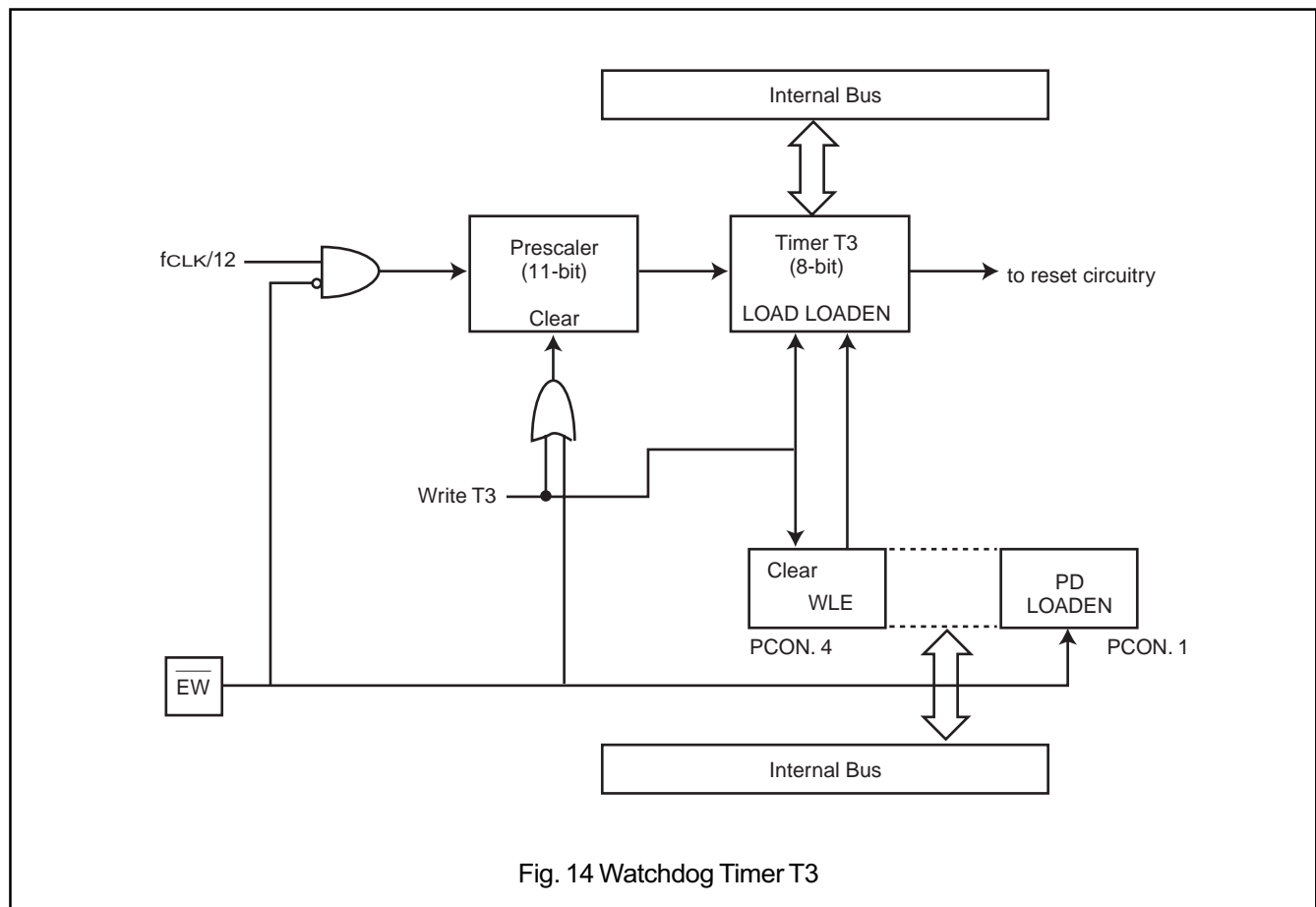

Fig. 14 Watchdog Timer T3

Pulse Width Modulated Outputs

The MX10F201FC contains two pulse width modulated output channels (see Figure. 15). These channels generate pulses of programmable length and interval. The repetition frequency is defined by an 8-bit prescaler PWMP, which supplies the clock for the counter. The prescaler and counter are common to both PWM channels. The 8-bit counter counts modulo 255, i.e., from 0 to 254 inclusive. The value of the 8-bit counter is compared to the contents of two registers: PWM0 and PWM1. Provided the contents of either of these registers is greater than the counter value, the corresponding PWM0 or PWM1 output is set LOW. If the contents of these registers are equal to, or less than the counter value, the output will be HIGH. The pulse-width-ratio is therefore defined by the contents of the registers PWM0 and PWM1. The pulse-width-ratio is in the range of 0 to 1 and may be programmed in increments of 1/255.

Buffered PWM outputs may be used to drive DC motors. The rotation speed of the motor would be proportional to the contents of PWMn. The PWM outputs may also be configured as a dual DAC. In this application, the PWM outputs must be integrated using conventional operational amplifier circuitry. If the resulting output voltages have to be accurate, external buffers with their own analog supply should be used to buffer the PWM outputs before they are integrated. The repetition frequency f_{PWM} , at the PWMn outputs is give by :

$$f_{PWM} = \frac{f_{OSC}}{2 \times (1 + PWMP) \times 255}$$

This gives a repetition frequency range of 123Hz to 31.4KHz ($f_{OSC} = 16\text{MHz}$). At $f_{OSC} = 24\text{MHz}$, the frequency range is 184Hz to 47.1KHz. By loading the PWM registers with either 00H or FFH, the PWM channels will output a constant HIGH or LOW level, respectively. Since the 8-bit counter counts modulo 255, it can never actually reach the value of the PWM registers when they are loaded with FFH.

When a compare register (PWM0 or PWM1) is loaded with a new value, the associated output is updated immediately. It does not have to wait until the end of the current counter period. Both PWMn output pins are driven by push-pull drivers. These pins are not used for any other purpose.

The PWM function is enabled by setting SPR EBTCON bit 2,3. After reset, SFR EBTCON bit 2,3 need to be set to use P1.4 or P1.5 as the PWM output, otherwise P1.4& P1.5 are general I/O ports.

Prescaler frequency control register PWMP	Reset Value = 00H							
PWMP (FEH)	7	6	5	4	3	2	1	0
	MSB				LSB			
PWMP.0-7	Prescaler division factor = PWMP + 1.							

Reading PWMP gives the current reload value. The actual count of the prescaler cannot be read.

	Reset Value = 00H							
PWM0 (FCH)	7	6	5	4	3	2	1	0
PWM1 (FDH)	MSB				LSB			

$$\text{PWM0/1.0-7} \text{ Low/high ratio of PWMn} = \frac{(\text{PWMn})}{255 - (\text{PWMn})}$$

EBTCON SFR (EBH)	7	6	5	4	3	2	1	0
	-	-	-	-	PWM1E	PWM0E	/EW	-

PWM1E : Selection of P1.4 function as either PWM output or a port line, After reset PWM1E bit is low, and P1.4 is a normal port line.

PWM0E : Selection of P1.5 function as either PWM output or a port line, After reset PWM0E bit is low, and P1.5 is a normal port line.

/EW : After reset, /EW bit is set, and WDT is disable.

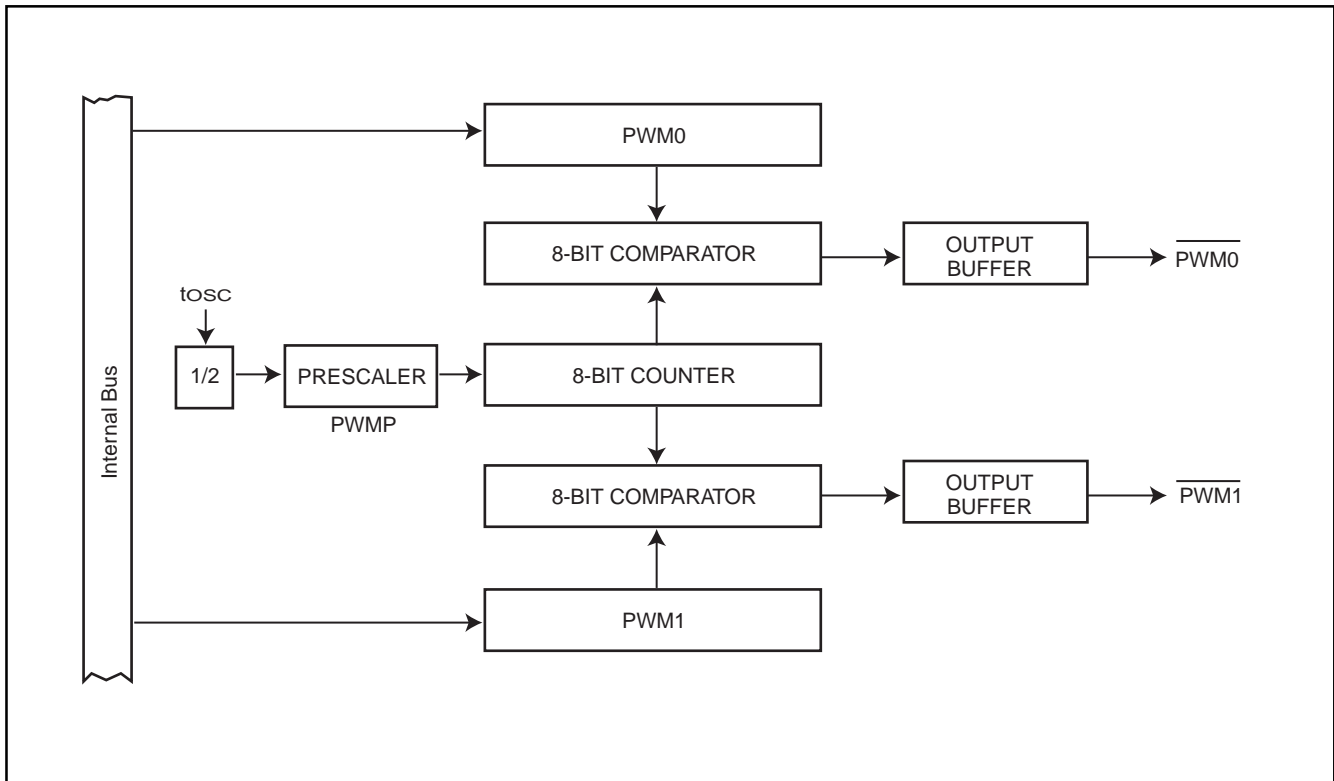

Fig. 15 Functional Diagram of Pulse Width Modulated Outputs



UART

This module is fully compatible to standard 80C51's UART.

MTP Program Memory**Features**

- 16 kilobyte electrically erasable internal MTP program memory.
- Programming and erasing voltage 12 Volt
- MTP (re) programming mechanism :
 - EPROM like parallel programming protocol
- Parallel programming :
 - Byte programming (8 us typical)
 - Chip erase less than 0.5 second typical
- 100 minimum erase/program cycles
- Advanced CMOS flash memory technology
- One security bit to protect internal ROM code.

General Description

MX10F201FC's MTP memory stores memory contents even after 100 erase and program cycles. The cell is designed to optimize the erase and programming mechanisms. In addition, the combination of advanced tunnel oxide processing and low internal electric fields for erase and programming operations produces reliable cycling. The MX10F201FC uses 12 Volt VPP supply to perform the Program/Erase algorithms.

PROGRAMMING AND PROGRAM VERIFY

MX10F201FC is byte programmable by using 10us programming pulse and it requires separate program verify pulse to read out the data to check if program is ok or not. The typical programming time for each 1k bytes is about 10ms at room temperature.

PROGRAMMING SPECIFICATION
Parallel Programming Mode

The parallel programming works in EPROM-like programming protocol. The MX10F201FC MTP provides 100 times cycles endurance. And the MX10F201FC MTP needs a 11.5~12.5 Volt VPP supply to perform the Program/Erase operation. Specially note that LOCK 2 is used to security protection. So if LOCK 2 bit is programmed, then PGMVFY, ERSVFY and normal READ are disabled from parallel programming mode. LOCK 1 and LOCK 3 are not used in this chip.

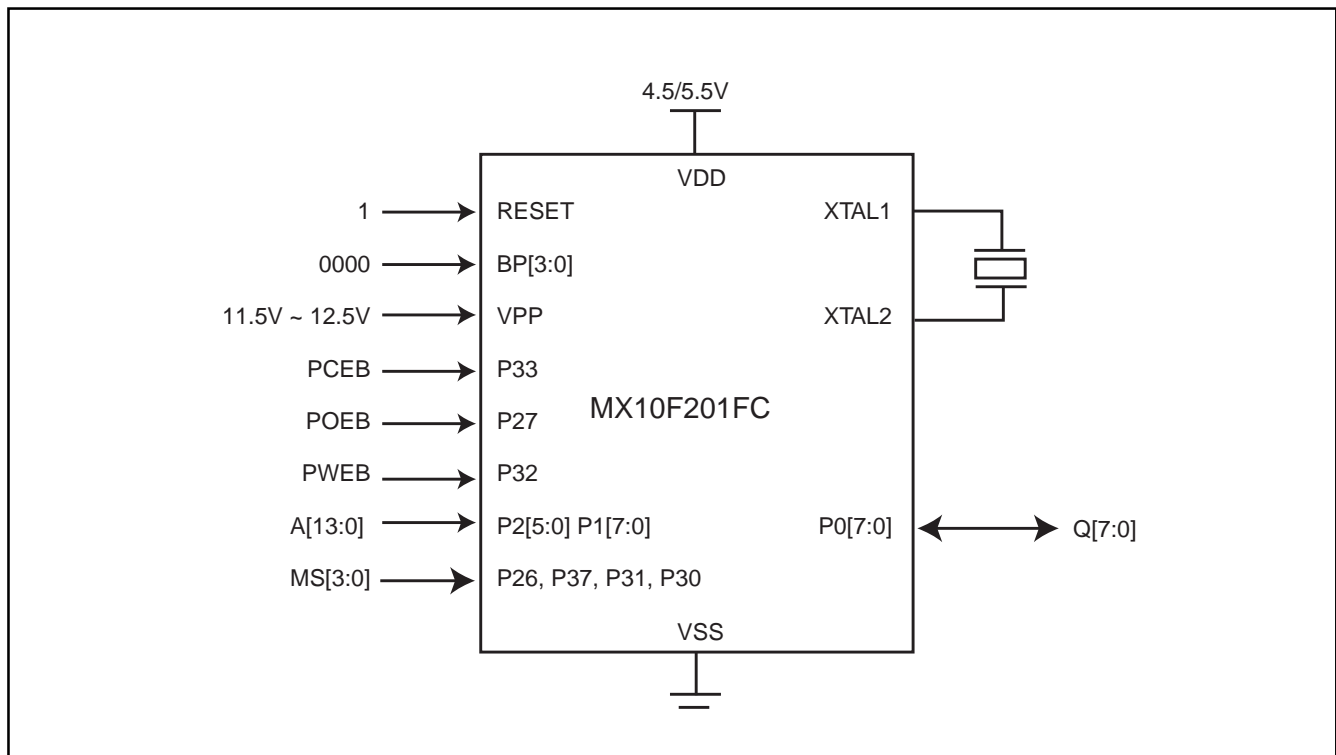
Table. 26 Pin Description

PIN NAME	SYMBOL	FUNCTION
P25~P20, P17~P10	PA13~PA8, PA7~PA0	Address Input
P07~ P00	Q[7:0]	Data Input/Output
P33	PCEB	Chip Enable Input
P27	POEB	Output Enable Input
P32	PWEB	Write Enable Input
VPP	VPP	Program Supply Voltage
P26, P37, P31, P30	MS[3:0]	Flash Mode Selection
VDD	VDD	Power Supply Voltage (5V)
VSS	GND	Ground Pin



Table. 27 parallel programming modes

External Pin	EA	P33	P27	P32	P2[5:0] P1[7:0]	P26, P37, P31, P30	P0[7:0]	P0[7:0]	
Module I/O	PVPP	PCEB	POEB	PWEB	PA[13:0]	MS[3:0]	PUOUT[7:0] PDOUT[7:0]	DI or DIA	Lock[3:1]
Standby	12V	1	X	X	X	X	FF,00	X	
Normal Read	12V	0	0	1	PA[13:0]	0000	Data	Z	
Initialize	12V	0	1	0.5sec pulse	X	1110	FF,00	X	000
Chip Erase	12V	0	1	0.5sec pulse	X	0001	FF,00	X	000
Program	12V	0	1	10us pulses	PA[13:0]	0011	FF,00	D[7:0]	
Erase Verify	12V	0	0	1	PA[13:0]	0100	Data	Z	
Program Verify	12V	0	0	1	PA[13:0]	0101	Data	Z	
Pgm LOCK	12V	0	1	10us pulse	PA[1:0]	0110	FF,00	X	Lock[i] 0 ->1
Erase Verify LOCK	12V	0	0	1	PA[1:0]=00	1001	LOCK[3:1]	Z	
Pgm Verify LOCK	12V	0	0	1	PA[1:0]=00	1011	LOCK[3:1]	Z	
Read Mft ID	12V	0	0	1	PA[1:0]=00	1111	MftID(C2H)	Z	
Read DeviceID	12V	0	0	1	PA[1:0]=01	1111	DeviceID(0DH)	Z	

- Note :
1. Program lock bits, program LOCK [1] to be 1 if PA [1:0] = 00
 Program lock bits, program LOCK [2] to be 1 if PA [1:0] = 01
 Program lock bits, program LOCK [3] to be 1 if PA [1:0] = 1x
 2. Verify erased LOCK bits if PA [1:0] = 00
 3. Verify programmed LOCK bits if PA [1:0] = 00
 4. Read Manufacture ID, Device ID
 PA [1:0] = 00 : Manufacture ID (C2H)
 PA [1:0] = 01 : Device ID (0DH)

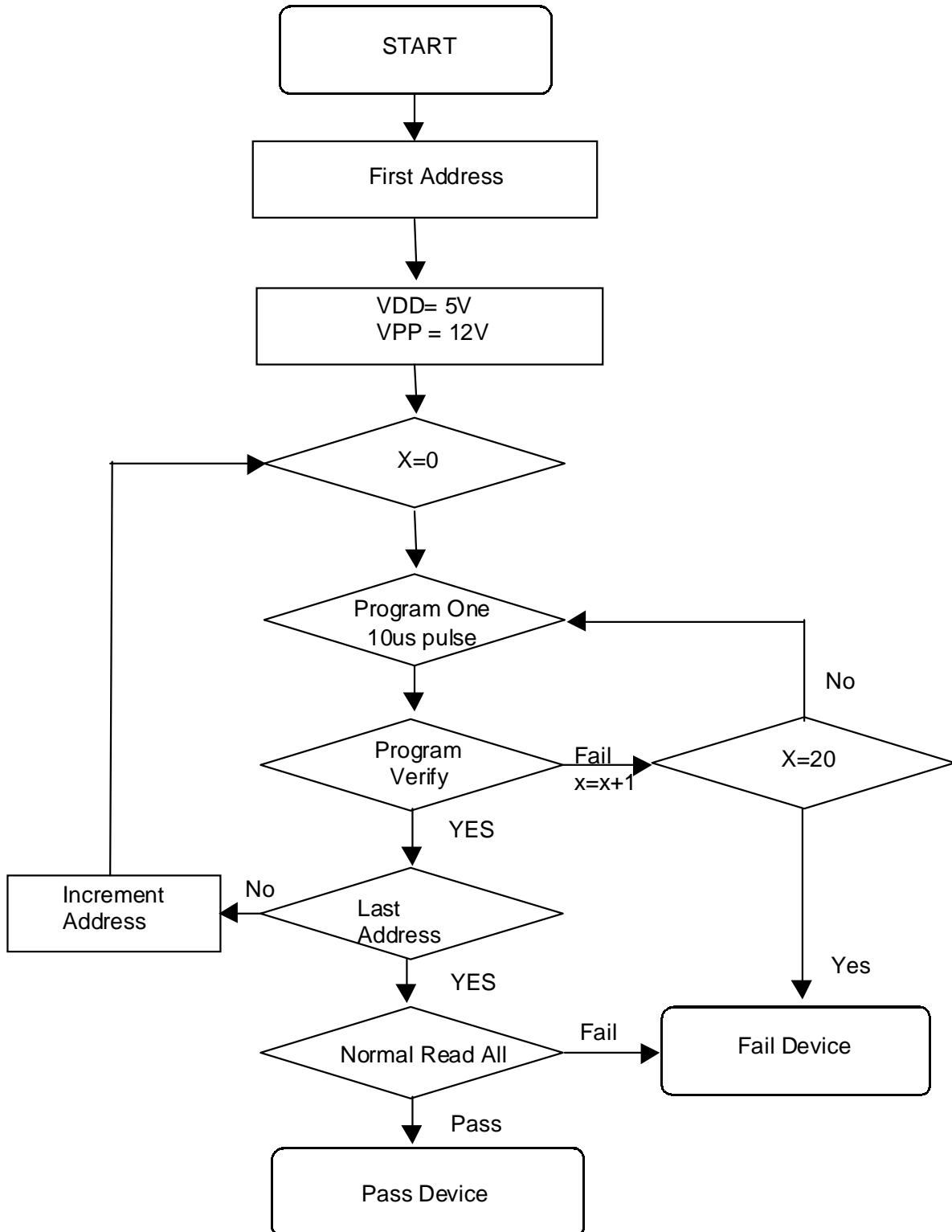
PROGRAM AND PROGRAM VERIFY FLOWCHART

ERASE and VERIFY FLOWCHART

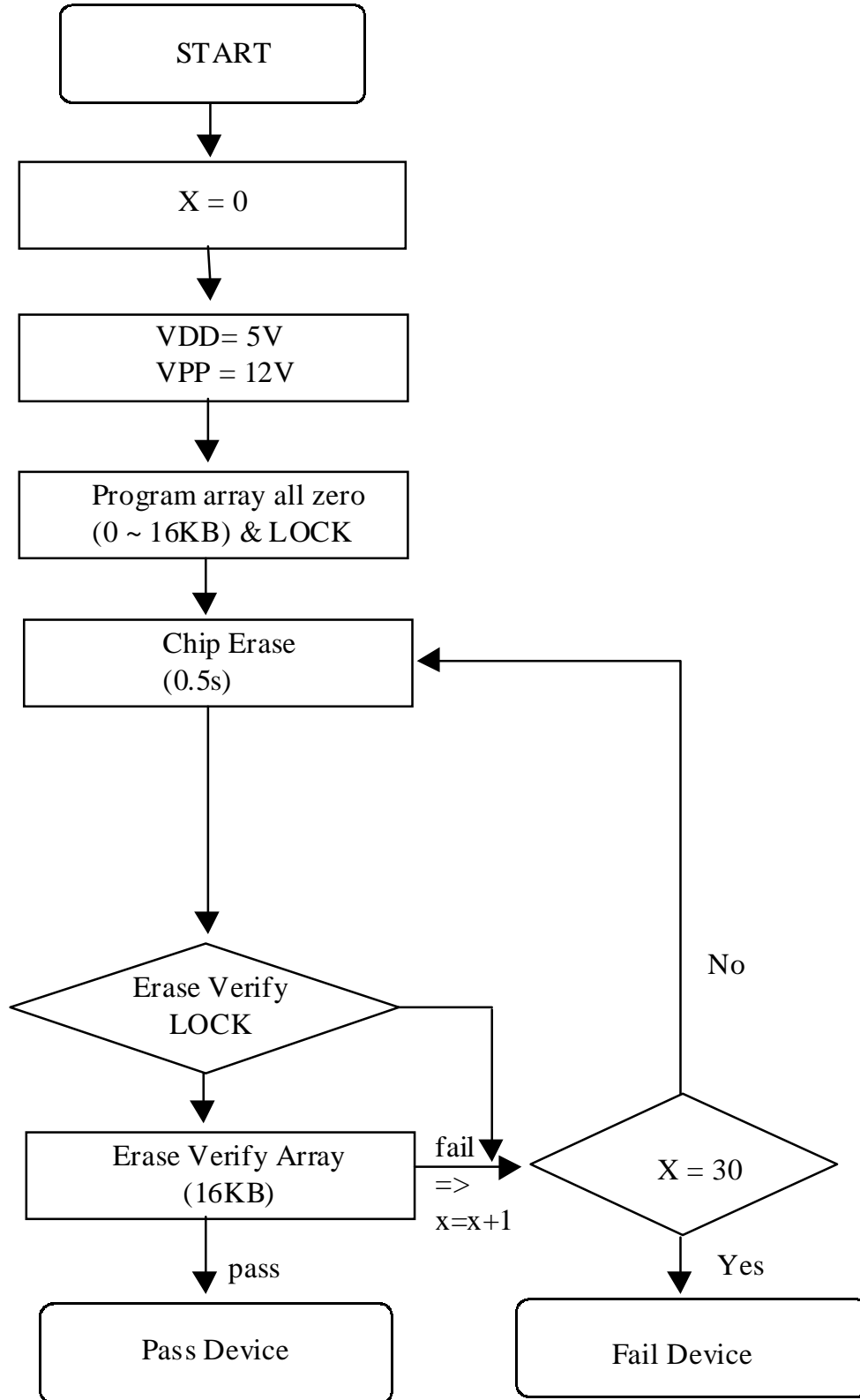

PROGRAM LOCK AND PROGRAM VERIFY LOCK FLOWCHART

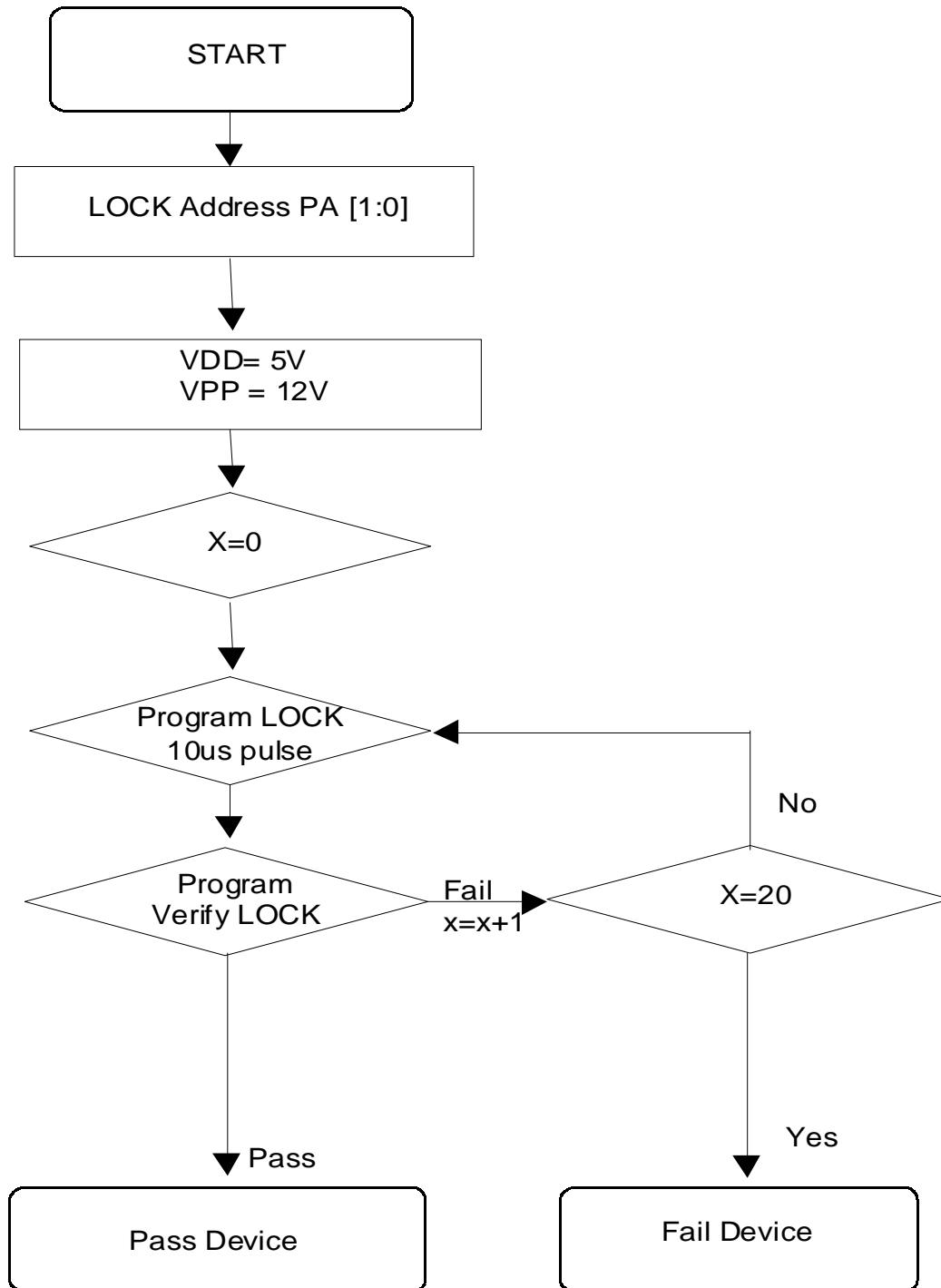

A. Timing diagram of Read signature and Normal read operations

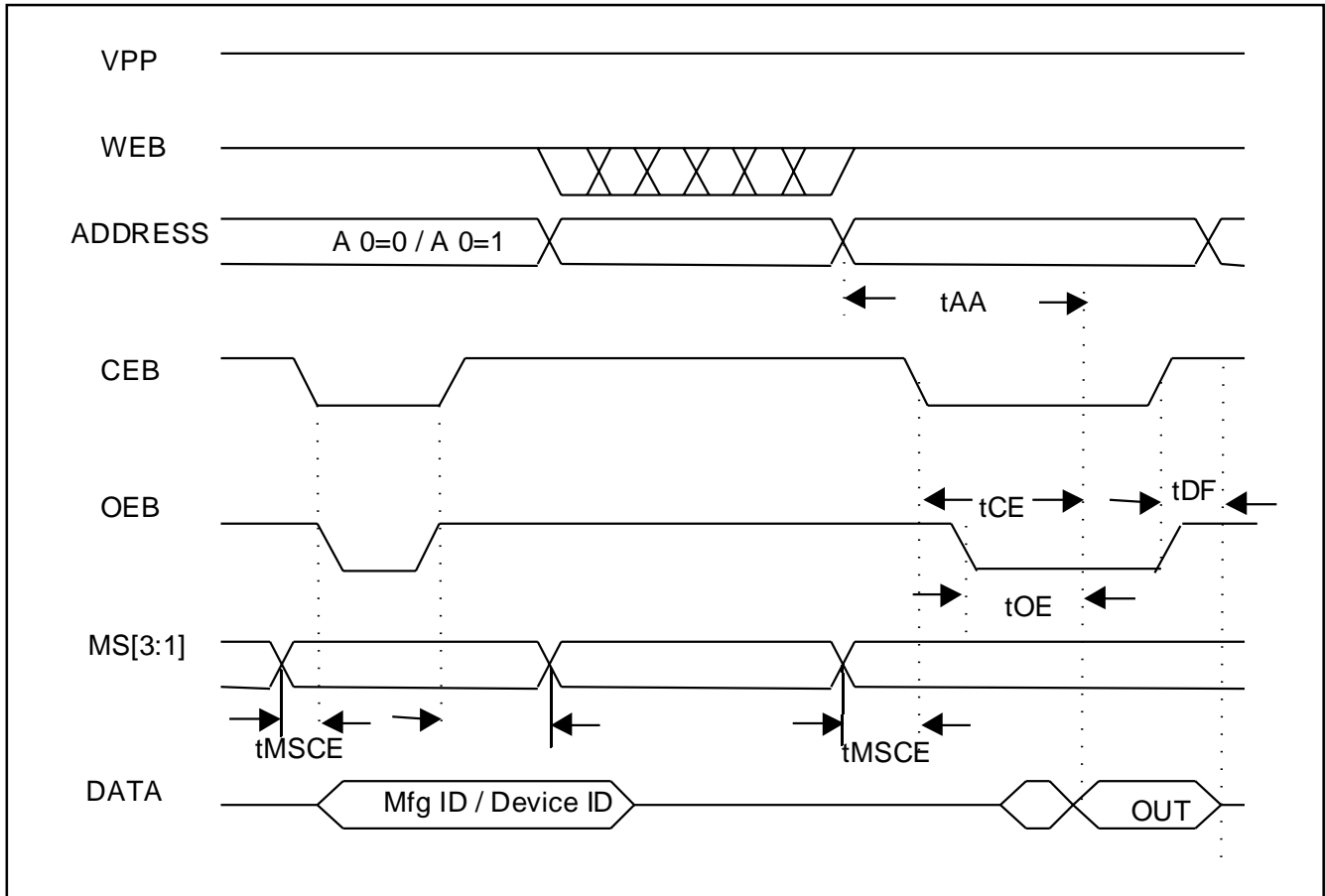

	tAA	tCE	tOE	tDF	tMSCE
Min.				0	100
Max.	130	130	50	20	
unit	ns	ns	ns	ns	ns

B. Timing Diagram of Erase and Erase Verify Array Operation

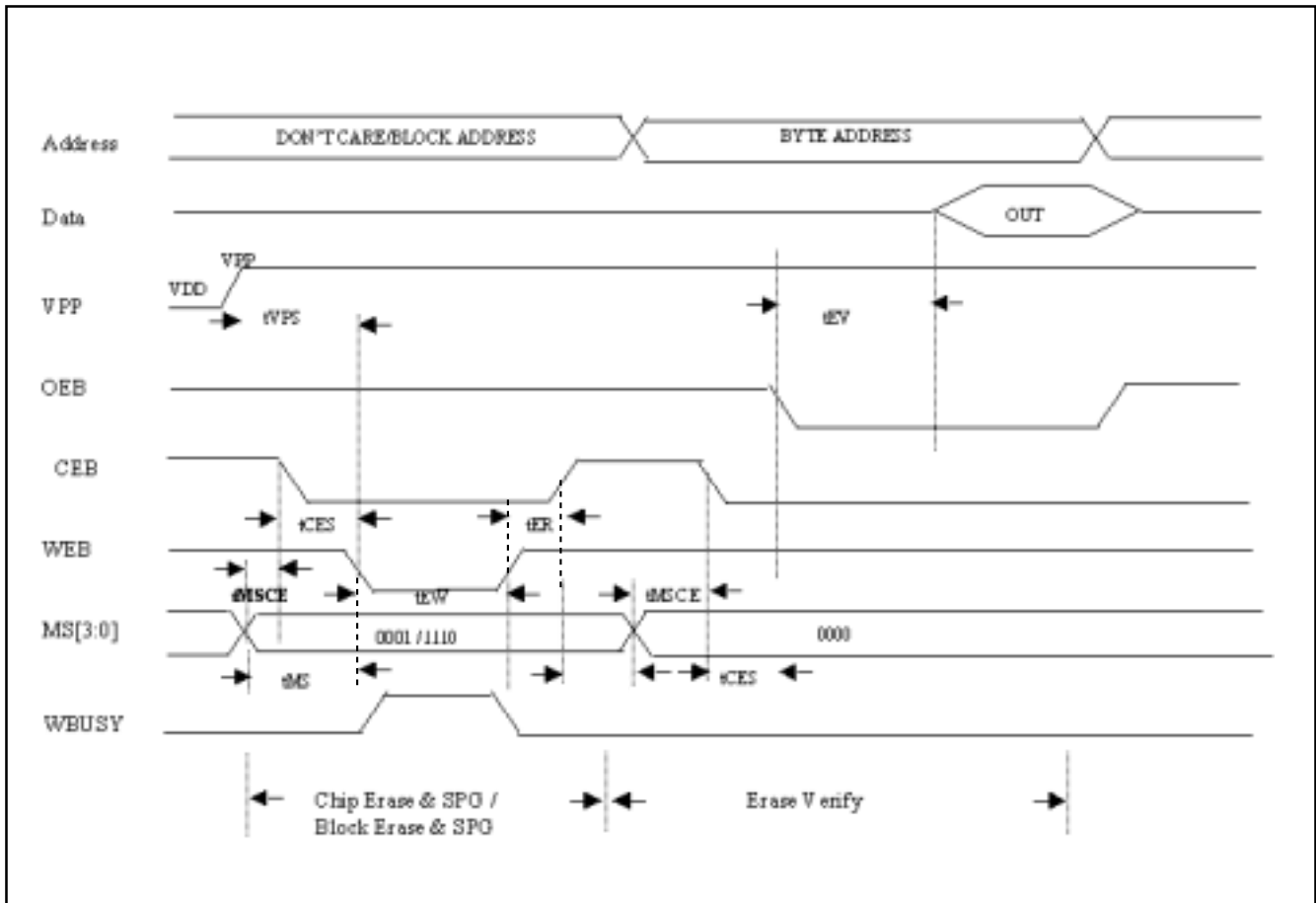

	tVPS	tMS	tCES	tER	tEW	tEV	tMSCE
Min.	2	200	100	100	0.5		100
Max.						200	
unit	us	ns	ns	ns	s	ns	ns

C. Timing Diagram of Erase and Erase Verify LOCK Operation

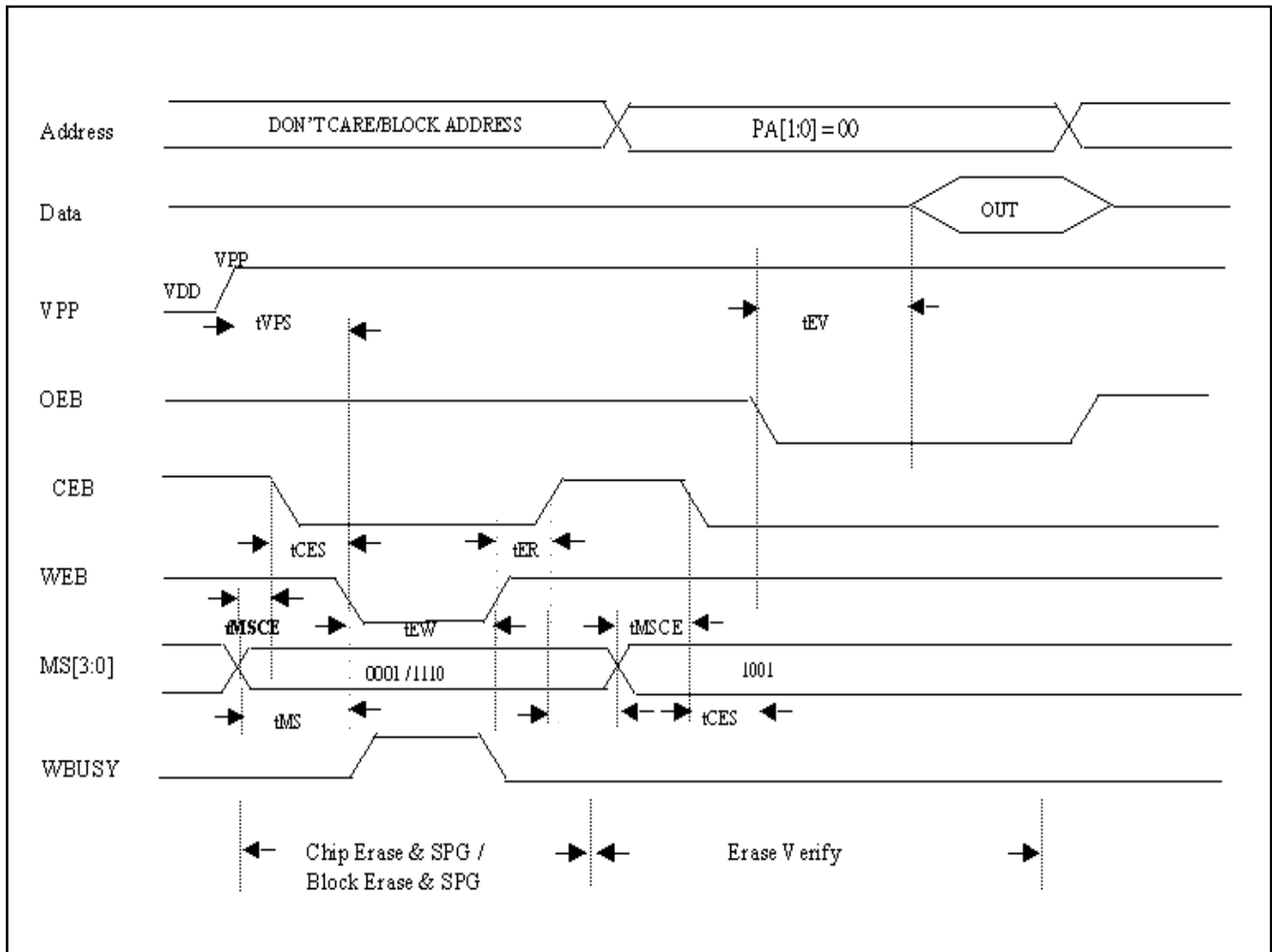

	t_{VPS}	t_{MS}	t_{CES}	t_{ER}	t_{EW}	t_{EV}	t_{MSCE}
Min.	2	200	100	100	0.5		100
Max.						200	
unit	us	ns	ns	ns	s	ns	ns

D. Timing Diagram of Program and Program Verify Operation

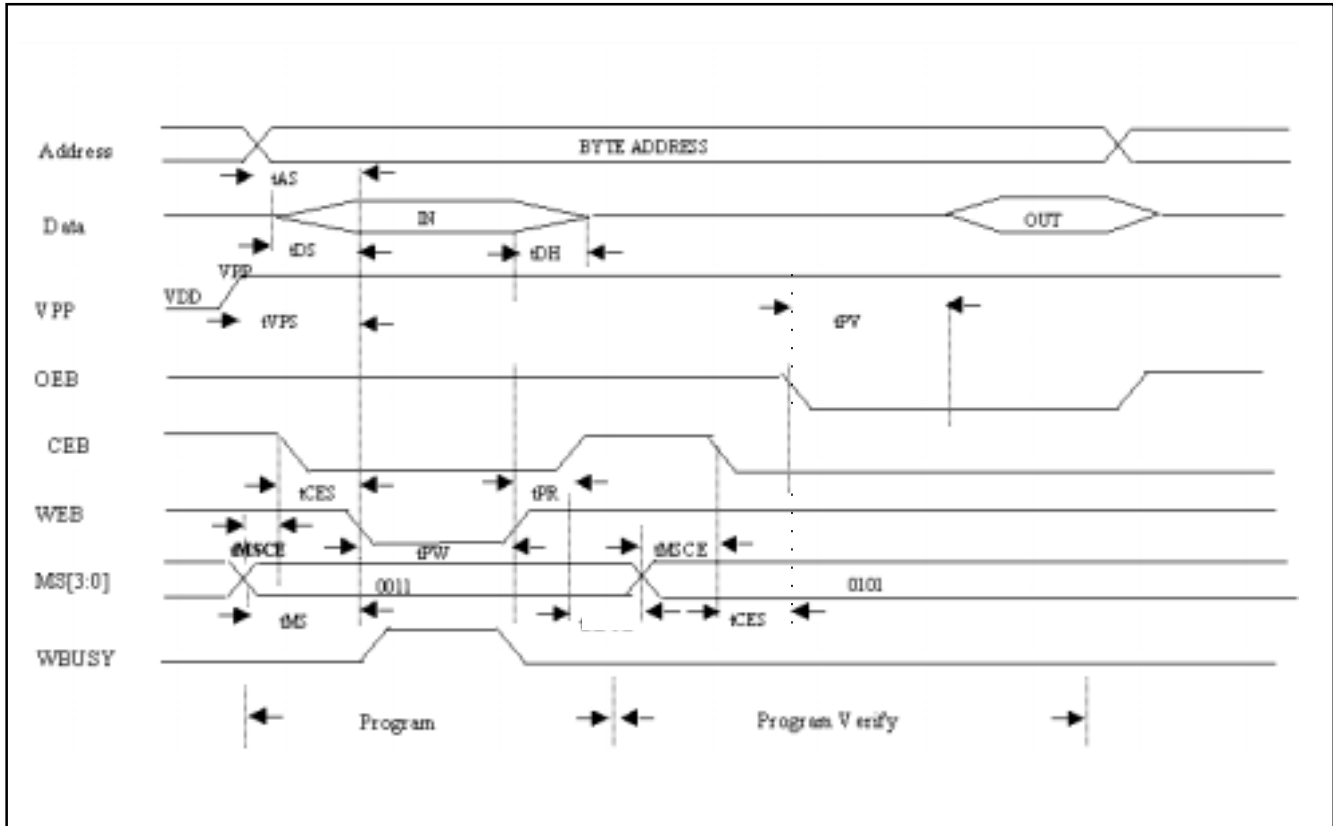

	tAS	tDS	tDH	tVPS	tCES	tMS	tPR	tPW	tPV	tMSCE
Min.	100	100	100	2	100	200	100	8		100
Max.									200	
unit	ns	ns	ns	us	ns	ns	ns	us	ns	ns

E. Timing Diagram of Program LOCK and Program Verify LOCK Operation

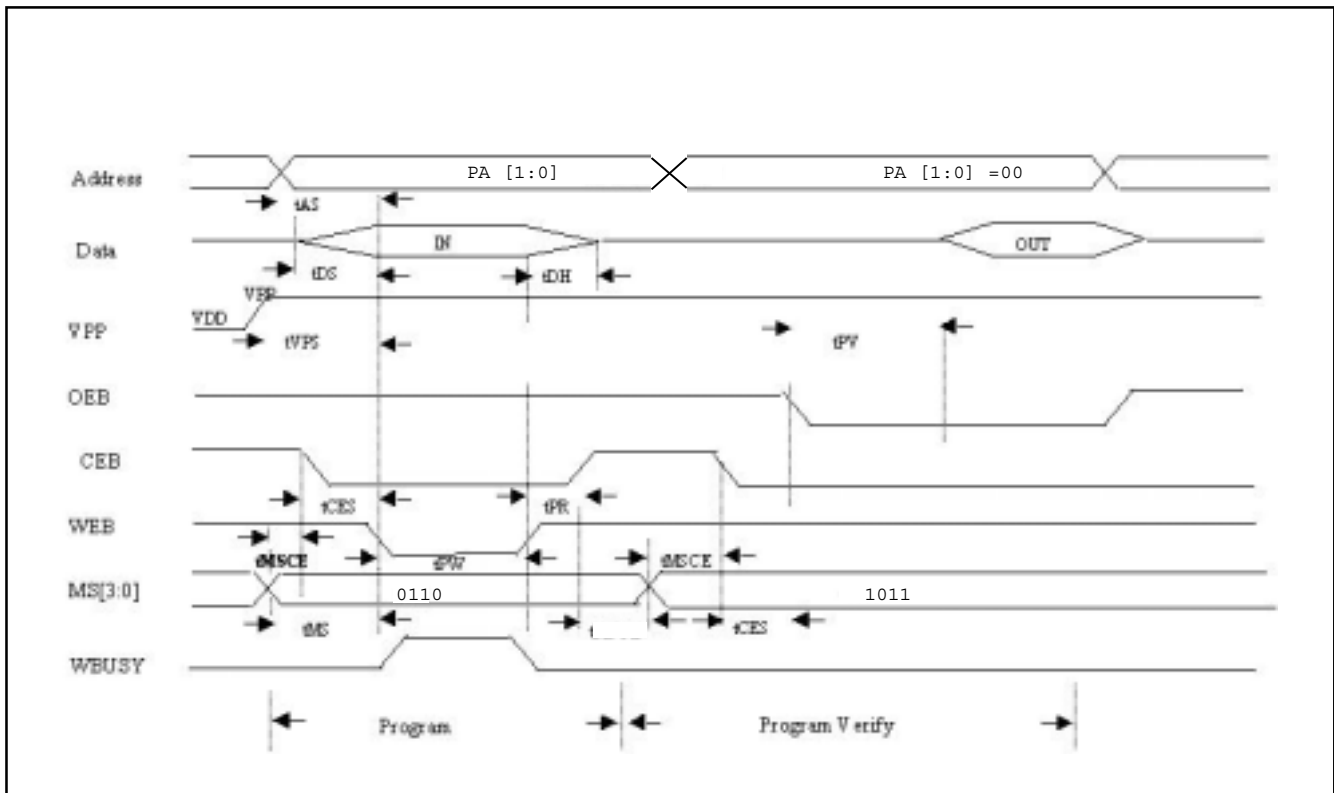

	tAS	tDS	tDH	tVPS	tCES	tMS	tPR	tPW	tPV	tMSCE
Min.	100	100	100	2	100	200	100	8		100
Max.									200	
unit	ns	ns	ns	us	ns	ns	ns	us	ns	ns

Note : OUT = { xxxx, LOCK [3], LOCK [2], LOCK [1], x}

Limiting Value

SYMBOL	PARAMETER	MIN	MAX	UNIT
VDD	Supply voltage	4.5	5.5	V
V _i	Input voltage (all inputs)	-0.5	VDD + 0.5	V
V _{VPP}	Voltage on VPP pin to VSS	0	13	V
I _{OL(max)}	Maximum IOL per I/O pin		15	mA
T _{stg}	Storage temperature	-65	150	°C
T _{amb}	Operating ambient temperature(for all devices)	0	70	°C

DC ELECTRICAL CHARACTERISTICS

SYMBOL	PARAMETER	CONDITIONS	MIN.	TYP.	MAX.	UNIT
Supply						
VDD	Normal operation supply voltage		4.5		5.5	V
I _{DD}	Operation supply current	f _{OSC} = 16MHZ		10	20	mA
		f _{OSC} = 12MHZ		8		mA
		f _{OSC} = 4MHZ		4		mA
I _{ID}	Supply current in idle mode	f _{OSC} = 16MHZ		8	12	mA
		f _{OSC} = 12MHZ		6		
		f _{OSC} = 4MHZ		2		
I _{SLP}	Supply current in single sleep mode	f _{OSC} = 16MHZ		4	8	mA
		f _{OSC} = 12MHZ		3		
		f _{OSC} = 4MHZ		1		
I _{D_{SLP}}	Supply current in dual sleep mode	f _{OSC} = 16MHZ		50	100	uA
		f _{OSC} = 12MHZ		45		
		f _{OSC} = 4MHZ		25		
I _{PD}	Supply current in power-sown mode	f _{OSC} = 16MHZ		1	30	uA
		f _{OSC} = 12MHZ		1		
		f _{OSC} = 4MHZ		1		
Inputs						
R _{INP}	Input resistance RESET	VDD=4.5V to 5.5V	15		100	kohm
I _L	Input leakage current; RESET	VDD=5V			120	uA
V _{IH1}	Input high voltage to XTAL1, XTAL3, RESET		0.7VDD		VDD+0.5 V	
PORTS P0~P3						
V _{IL}	Input low voltage		-0.5		0.2VDD-0.1 V	
V _{IH}	Input high voltage, except XTAL1, XTAL3, RST		0.2VDD		VDD+0.5 V	
			+0.9			
I _{IL}	Logical 0 input current	VIN=0.4V, VDD=5V	-1		-100	uA
I _{TL}	Logical 1 to 0 transition current	VIN=2.0V			-650	uA

Outputs : P0~P3

SYMBOL	PARAMETER	CONDITIONS	MIN.	TYP.	MAX.	UNIT
V_{OL}	Output low voltage	$V_{DD}=4.5V, I_{OL}=1.6mA$			0.4	V
V_{OH}	Output high voltage	$V_{DD}=4.5V, I_{OH}=-3.3mA$	$V_{DD}-0.7$			V
I_{OL}	Low level output sink current	$V_o \leq 0.4V, V_{DD}=5V$	10	13		mA
I_{OH}	High level pull-up output source current					
	Strong pull-up	$V_o = V_{DD}-0.4V, V_{DD}=5V$	4	6		mA
	Weak pull-up	$V_o = V_{DD}-0.4V, V_{DD}=5V$	15	30		uA
C_{IO}	Pin capacitance (except EA)				15	pF

LCD DRIVER CHARACTERISTICS

SYMBOL	PARAMETER	CONDITIONS	MIN.	TYP.	MAX.	UNIT
Supply						
VLCD	LCD operation supply voltage		4.5		VDD	V
VSS	DC voltage component; all backplane and segment drivers				100	mV
LCD driver outputs						
R_{BP}	Output impedance BP0~BP3		6		20	kohm
R_S	Output impedance S0~S31		6		20	kohm
f_{LCD}	LCD scan frequency	Ratio: 1:1, 1:2, 1:4		61		Hz
		Ratio: 1:3		81		Hz

RCP OSCILLATOR CHARACTERISTICS

	5.5	5	4.5	3.3	3	2.7
100kohm	9.36	9.19	8.7	7.4	6.48	6.15
40kohm	15.98	14.81	14.29	10.95	10.12	8.99

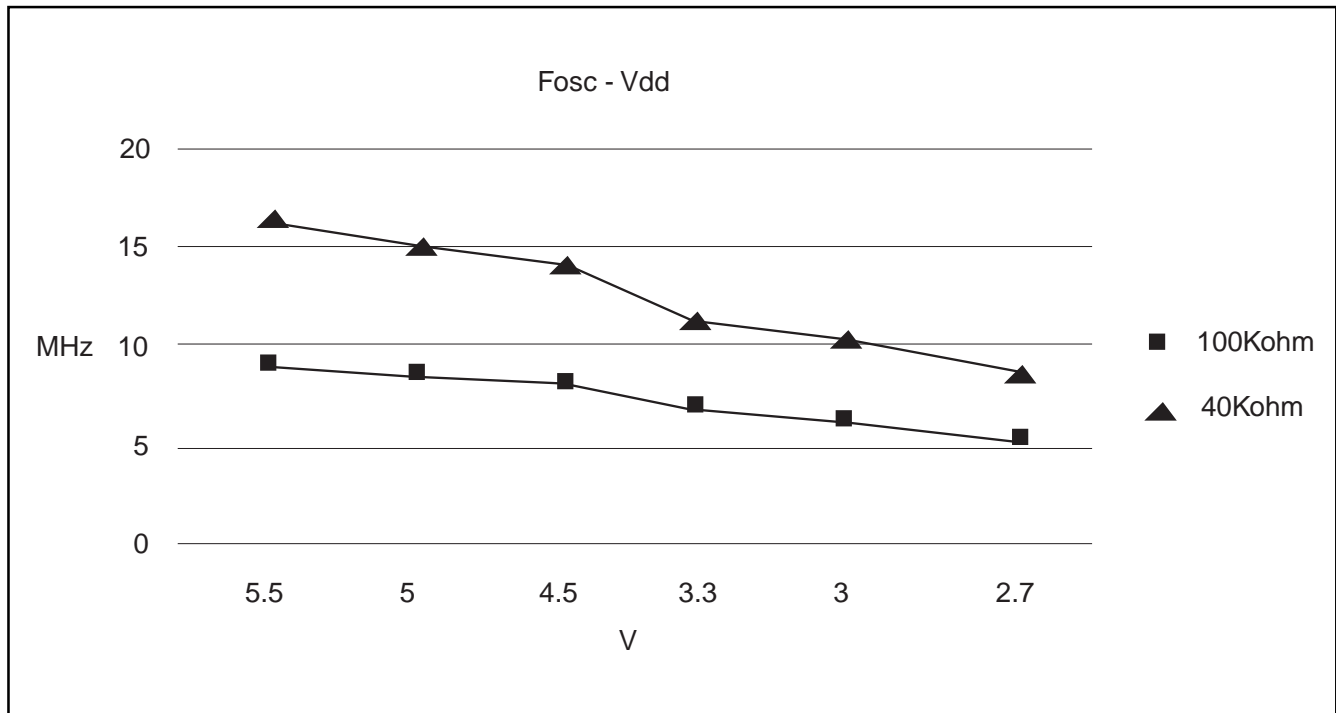
AC CHARACTERISTICS

SYMBOL	PARAMETER	CONDITIONS	MIN.	TYP.	MAX.	UNIT
System (CPU) clock						
f _C	Oscillator frequency		2		16	MHz
32.768KHz LCD Oscillator						
f _{xtal}	32.768KHz Oscillator frequency			32.768		KHz

PACKAGE INFORMATION

100-PIN PQFP

ITEM	MILLIMETERS	INCHES
A	24.80 ± .40	.976 ± .016
B	20.00 ± .13	.787 ± .005
C	14.00 ± .13	.551 ± .005
D	18.80 ± .40	.740 ± .016
E	12.35 [REF]	.486 [REF]
F	.83 [REF]	.033 [REF]
G	.58 [REF]	.023 [REF]
H	.30 [Typ.]	.012 [Typ.]
I	.65 [Typ.]	.026 [Typ.]
J	2.40 [Typ.]	.094 [Typ.]
K	1.20 [Typ.]	.047 [Typ.]
L	.15 [Typ.]	.006 [Typ.]
M	.10 max.	.004 max.
N	2.75 ± .15	.108 ± .006
O	.10 min.	.004 min.
P	3.30 max.	.130 max.

NOTE: Each lead centerline is located within .25mm [.01 inch] of its true position [TP] at a maximum material condition.

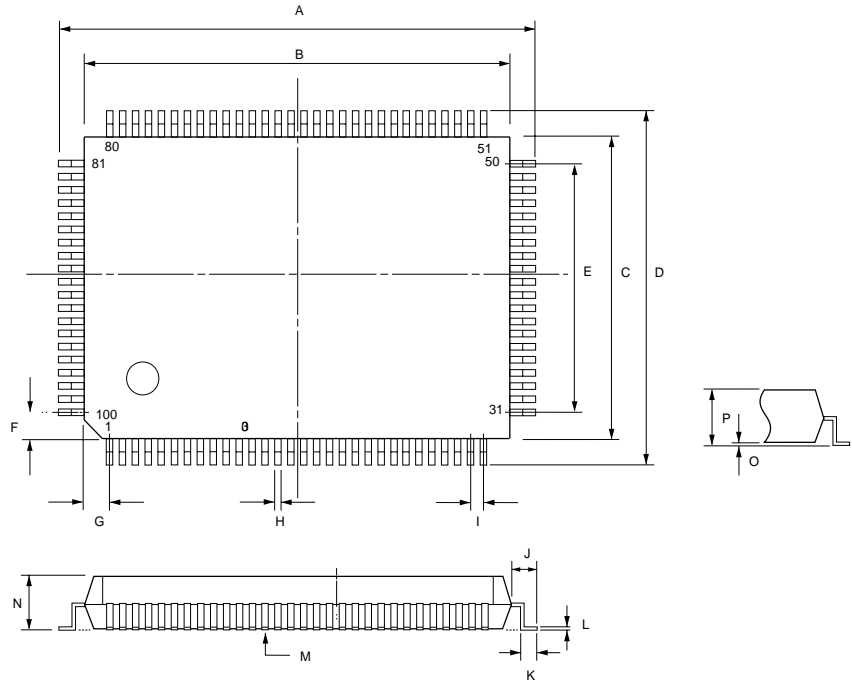



MX10F201FC

REVISION	DESCRIPTION	PAGE	DATE
0.1	Modify Table. 15 INTCON SFR (C8H)-->(C0H)	P14	SEP/06/2002



MX10FM201FC

MACRONIX INTERNATIONAL Co., LTD.

HEADQUARTERS:

TEL:+886-3-578-6688

FAX:+886-3-563-2888

EUROPE OFFICE:

TEL:+32-2-456-8020

FAX:+32-2-456-8021

JAPAN OFFICE:

TEL:+81-44-246-9100

FAX:+81-44-246-9105

SINGAPORE OFFICE:

TEL:+65-348-8385

FAX:+65-348-8096

TAIPEI OFFICE:

TEL:+886-2-2509-3300

FAX:+886-2-2509-2200

MACRONIX AMERICA, INC.

TEL:+1-408-453-8088

FAX:+1-408-453-8488

CHICAGO OFFICE:

TEL:+1-847-963-1900

FAX:+1-847-963-1909

[http : //www.macronix.com](http://www.macronix.com)