

SparX-G8e™-Enhanced 8-Port Integrated Gigabit Ethernet Switch with Transceivers

VSC7398 SparX-G8e is the highly integrated, single-chip Gigabit Ethernet switch with eight Integrated GbE Copper PHY ports. As part of the Vitesse SparX™ Family of Switches, SparX-G8e delivers high performance with easy migration paths, and comprehensive system solutions that enable ultrashort time-to-market and market-leading system cost.

A Vitesse Switch Family Member

SparX-G8 is a part of the Vitesse SparX™ Family of Unmanaged or SparX-G8e is a part of the Vitesse SparX™ Family of Unmanaged or Web-managed Switches, taking the family into a new generation of integration. With its eight integrated tri-speed Gigabit Ethernet copper transceivers (with the option of multiplexing two as tri-speed RGMII/GMII), and several integrated management interfaces, it is specifically targeted at SMB and SOHO unmanaged applications; with its V-Core CPU (on-chip 8051) and parallel CPU interface, it enables web-managed and managed switch applications.

Being a member of the switch family provides a number of unique advantages when designing with the chip: there is nearly 100% software compatibility between the switch family members; software written for SparX-G8e can easily be used with other switch configurations in the family, and vice-versa; and with minimal effort and time, designs can be upgraded to higher port counts, or migrated to other configurations or future technology. Building a product family is easy when designing with Vitesse switches!

The Vitesse SparX™ Family of Switches

SparX-G8e shares the unique traits of the Vitesse SparX Family of Switches. The highly integrated switch supports 136 kilobytes of on-chip frame buffer, and the integration of the copper PHY as well as an internal oscillator circuit simplifies PCB layout to reduce time and cost. Further trimming down system cost is the industry's lowest power, fully integrated, Switch-plus-Copper PHY technology.

The switches provide for high performance designs with their non-blocking, wire-speed performance, which includes wire-speed MAC address learning.

Designing both unmanaged and web-managed solutions is straightforward. The chips offer an internal V-Core CPU (on-chip 8051) and serial and parallel CPU interfaces, and support a host of management protocols such as GxRP, SNMP, and three flavors of Spanning Tree: Standard STP, Multiple STP, and Rapid STP.

Controlling networks operated by the Vitesse switches is simple; advanced classification with IPv4 and IPv6 support, along with port DSCP remarking and 802.1X authentication support, provides flexible QoS operation. This is backed up by Layer 2-4 link aggregation and VLAN support, enabling managed switches to be deployed.

APPLICATIONS

- 8-port unmanaged Gigabit Ethernet SMB/SOHO switch
- 8-port web-managed Gigabit Ethernet SMB/SOHO switch

SPECIFICATIONS

- 25 MHz LVTTTL reference clock
- 1.2V core power supply
- 3.3V interface power supply

With its unique low power dissipation, the VSC7398 enables fanless operation, thereby providing higher system reliability and lower noise, both to the benefit of the user.

Designing with Vitesse SparX Family of Switches means designing with the complete Vitesse solution: Vitesse provides a comprehensive, web-managed switch software system for the V-Core CPU (internal 8051). This is in addition to the unmanaged and smart managed software systems for 8051, which are also included. For homegrown software development, the Vitesse full platform and OS independent switch API is supplied. Accompanying the software systems are the Vitesse Switch reference systems. These are production-ready hardware designs that also serve as evaluation platforms. The Vitesse solution is supplied with a comprehensive collateral package, including software source code, full documentation, and an in-depth qualification report for easy pre-evaluation.

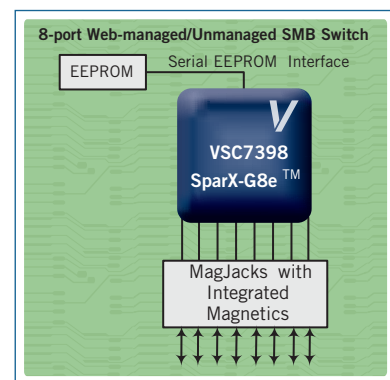

Features

- Eight Gigabit Ethernet ports with non-blocking wire-speed performance
- Eight tri-speed (10/100/1000 Mbps) copper transceivers (IEEE 802.3ab compliant), two of which (multiplexed internally) can be used as tri-speed (RGMII/GMII) interface
- 176 kilobytes on-chip frame buffer
- SNMP and Web-based management with either V-Core CPU (on-chip 8051 CPU with royalty-free, web-managed software stack) or off-chip 8-bit CPU
- DSCP remarking for both IPv4 and IPv6 frames
- Jumbo frame support at all speeds (10/100/1000 Mbps)
- Programmable multilayer classifier with four QoS classes
- 8 k MAC addresses and 4 k VLANs (IEEE 802.1Q), as well as 8 k IP multicast group support
- Flexible link aggregation support based on Layer-2 through Layer-4 information (IEEE 802.3ad)
- Full-duplex flow control (IEEE 802.3X) and half-duplex backpressure, symmetric and asymmetric
- Multicast and broadcast storm control, as well as flooding control
- Multiple protocol support: IEEE 802.1D, IEEE 802.1w, IEEE 802.1s, and IEEE 802.1X
- Wire-speed automatic learning and aging
- Vitesse VeriPHY™ cable diagnostics and SimpliPHY™ magnetics technology

Benefits

- Ensures maximum data throughput in highly loaded networks
- Reduces the need for any PHY components thereby significantly reducing overall systems cost
- Eliminates the need for external buffer memory while maintaining high peak load performance
- Enables advanced switch management, using run-time protocols, and low cost unmanaged/web-managed operation
- Enables LAN edge products to generate standard priority that can be used in the core network
- Connects effortlessly to networks, hosts, and controllers that use up to 9.6-kilobyte frames
- Optimizes network performance to support any digital stream, from internet browsing to VoIP and video
- Stores a large amount of stations at wire-speed in the on-chip MAC Table, ensuring optimal network performance and scalability
- Provides high bandwidth uplinking abilities
- Ensures loss-less data transmission while supporting existing legacy Ethernet equipment
- Eliminates unwanted flooding of ports, and thereby increases overall network performance
- Supports complex network topologies with fast failure recovery and access control
- Reduces CPU overhead and enables the CPU to allocate additional cycles for protocol processing
- Enables real-time cable diagnostics and low-cost magnetics

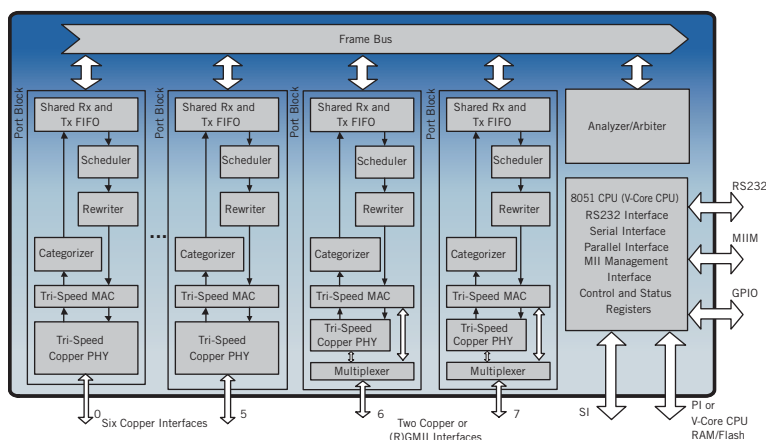

Related Vitesse Products

Visit www.vitesse.com for information about other related Vitesse products.



741 Calle Plano • Camarillo, CA 93012 USA • Tel: +1.800.VITESSE • +1.805.388.3700 • Fax: +1.805.987.5896 • www.vitesse.com

Vitesse Semiconductor Corporation