

ANALOG PERIPHERALS

- **10-bit ADC**
 - ± 1 LSB INL; No Missing Codes
 - Programmable Throughput up to 200ksps
 - Up to 21 External Inputs; Programmable as Single-Ended or Differential
 - Data Dependent Windowed Interrupt Generator
 - Built-in Temperature Sensor ($\pm 3^\circ\text{C}$)
- **Two Comparators**
 - Programmable Hysteresis and Response Time
 - Configurable as Wake-Up or Reset Source
 - Low Current (0.4uA)
- **POR/Brown-out Detector**

ON-CHIP DEBUG

- On-Chip Debug Circuitry Facilitates Full Speed, Non-Intrusive In-System Debug (No Emulator Required!)
- Provides Breakpoints, Single Stepping
- Inspect/Modify Memory and Registers
- Superior Performance to Emulation Systems Using ICE-Chips, Target Pods, and Sockets
- Low Cost, **Complete** Development Kit

SUPPLY VOLTAGE2.7V to 3.6V

- Typical Operating Current: 7mA @ 25MHz
15uA @ 32kHz
- Typical Stop Mode Current: <0.1uA

HIGH SPEED 8051 μC CORE

- Pipelined Instruction Architecture; Executes 70% of Instructions in 1 or 2 System Clocks
- Up to **25 MIPS** Throughput with 25MHz System Clock
- Expanded Interrupt Handler

MEMORY

- 1280 Bytes Internal Data RAM (256 + 1k)
- 16k Bytes FLASH; In-System Programmable in 512-Byte Sectors

DIGITAL PERIPHERALS

- 29 Port I/O (All 5V Tolerant with High Sink Current)
- Hardware SMBus™ (I2C™ Compatible), SPI™, and UART Serial Ports Available Concurrently
- Programmable 16-bit Counter/Timer Array with Five Capture/Compare Modules, WDT
- Four General Purpose 16-bit Counter/Timers
- Real-Time Clock Mode Using Timer or PCA

CLOCK SOURCES

- Internal Oscillator: 24.5MHz, 2% Accuracy Supports UART Operation
- External Oscillator: Crystal, RC, C, or Clock (1 or 2 Pin Modes)
- Can Switch Between Clock Sources On-The-Fly; Useful in Power Saving Modes

32-Pin LQFP Package

Temperature Range: -40°C to $+85^\circ\text{C}$

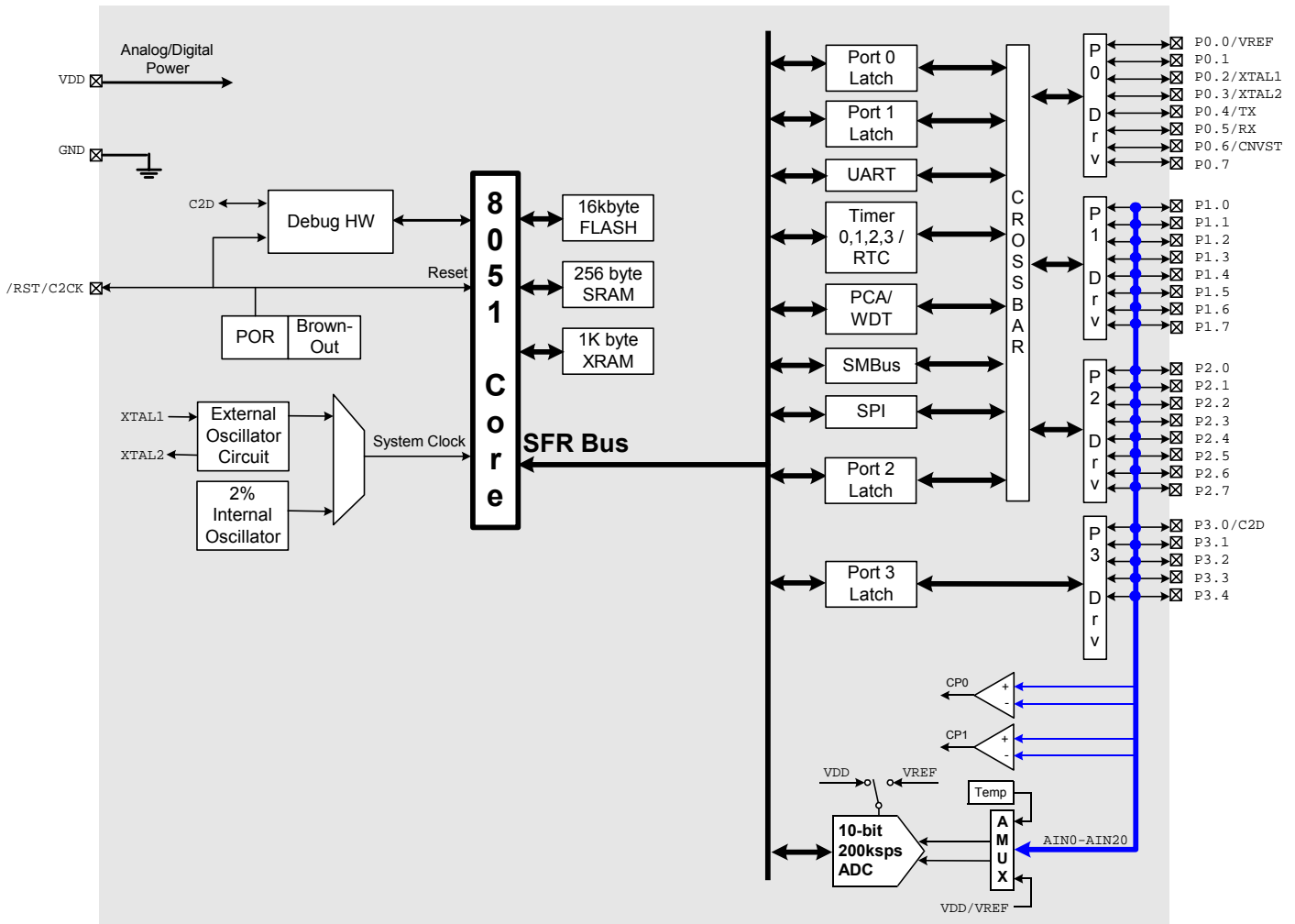

SELECTED ELECTRICAL SPECIFICATIONS TA = -40°C to +85°C, VDD=2.7V unless otherwise specified.

PARAMETER	CONDITIONS	MIN	TYP	MAX	UNITS
GLOBAL CHARACTERISTICS					
Supply Voltage		2.7		3.6	V
Supply Current	Clock=25MHz		7		mA
	Clock=1MHz		0.5		mA
	Clock=32kHz; VDD Monitor Disabled		15		μA
Supply Current (shutdown)	Oscillator off; VDD Monitor Enabled		10		μA
	Oscillator off; VDD Monitor Disabled		<0.1		μA
Clock Frequency Range		DC		25	MHz
INTERNAL OSCILLATOR					
Frequency		24.0	24.5	25.0	MHz
A/D CONVERTER					
Resolution			10		bits
Integral Nonlinearity				± 1	LSB
Differential Nonlinearity	Guaranteed Monotonic			± 1	LSB
Signal-to-Noise Plus Distortion		53			dB
Throughput Rate				200	ksps
COMPARATORS					
Mode0 Response Time	(CP+)-(CP-) = 100mV		0.10		μs
Mode0 Supply Current			7.6		μA
Mode1 Response Time	(CP+)-(CP-) = 100mV		0.18		μs
Mode1 Supply Current			3.2		μA
Mode2 Response Time	(CP+)-(CP-) = 100mV		0.32		μs
Mode2 Supply Current			1.3		μA
Mode3 Response Time	(CP+)-(CP-) = 100mV		1.0		μs
Mode3 Supply Current			0.40		μA

PACKAGE INFORMATION

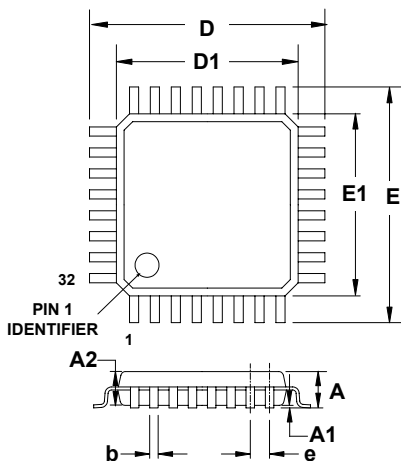

	MIN (mm)	NOM (mm)	MAX (mm)
A	-	-	1.60
A1	0.05	-	0.15
A2	1.35	1.40	1.45
b	0.30	0.37	0.45
D	-	9.00	-
D1	-	7.00	-
e	-	0.80	-
E	-	9.00	-
E1	-	7.00	-

C8051F310DK DEVELOPMENT KIT

