

ANALOG PERIPHERALS

10-bit ADC

- ± 1 LSB INL; Guaranteed Monotonic
- Programmable Throughput up to 100ksps
- 12 External Inputs; Programmable as Single-Ended or Differential
- Programmable Amplifier Gain: 16, 8, 4, 2, 1, 0.5
- Data Dependent Windowed Interrupt Generator
- Built-in Temperature Sensor ($\pm 3^\circ\text{C}$)

High-Voltage Differential Amplifier

- 60V Common Mode Input Range
- Offset Adjust from -60V to $+60\text{V}$
- 16 Gain Settings from 0.05 to 16

8-bit ADC

- Programmable Throughput up to 500ksps
- 8 External Inputs; Programmable as Single-Ended or Differential
- Programmable Amplifier Gain: 4, 2, 1, 0.5

Two 12-bit DACs

Three Comparators

Internal Voltage Reference

Precision VDD Monitor/Brown-out Detector

ON-CHIP JTAG DEBUG & BOUNDARY SCAN

- On-Chip Debug Circuitry Facilitates Full Speed, Non-Intrusive In-System Debug (No Emulator Required!)
- Provides Breakpoints, Single Stepping, Watchpoints, Stack Monitor, Program Trace Memory
- Inspect/Modify Memory and Registers
- Superior Performance to Emulation Systems Using ICE-Chips, Target Pods, and Sockets
- IEEE1149.1 Compliant Boundary Scan

HIGH SPEED 8051 μC CORE

- Pipe-lined Instruction Architecture; Executes 70% of Instructions in 1 or 2 System Clocks
- Up to 25MIPS Throughput with 25MHz System Clock
- Expanded Interrupt Handler

MEMORY

- 4352 Bytes Internal Data RAM (256 + 4k)
- 64k Bytes In-System Programmable FLASH Program Memory
- External 64k Byte Data Memory Interface

CAN Bus 2.0B

- 32 Message Objects
- "Mailbox" implementation only interrupts CPU when needed

DIGITAL PERIPHERALS

- 64 Port I/O; All are 5V tolerant
- Hardware SMBus™ (I2C™ Compatible), SPI™, and Two UART Serial Ports Available Concurrently
- Programmable 16-bit Counter Array with 6 Capture/Compare Modules
- Five General Purpose 16-bit Counter/Timers
- Dedicated Watch-Dog Timer; Bi-directional Reset

CLOCK SOURCES

- Internal Programmable 2% Oscillator: Up to 25MHz
- External Oscillator: Crystal, RC, C, or Clock
- Real-Time Clock Mode using Timer 3 or PCA

SUPPLY VOLTAGE 2.7V to 3.6V

- Typical Operating Current: 10mA @ 25MHz
- Multiple Power Saving Sleep and Shutdown Modes

100-Pin TQFP; Temp Range -40°C to $+85^\circ\text{C}$

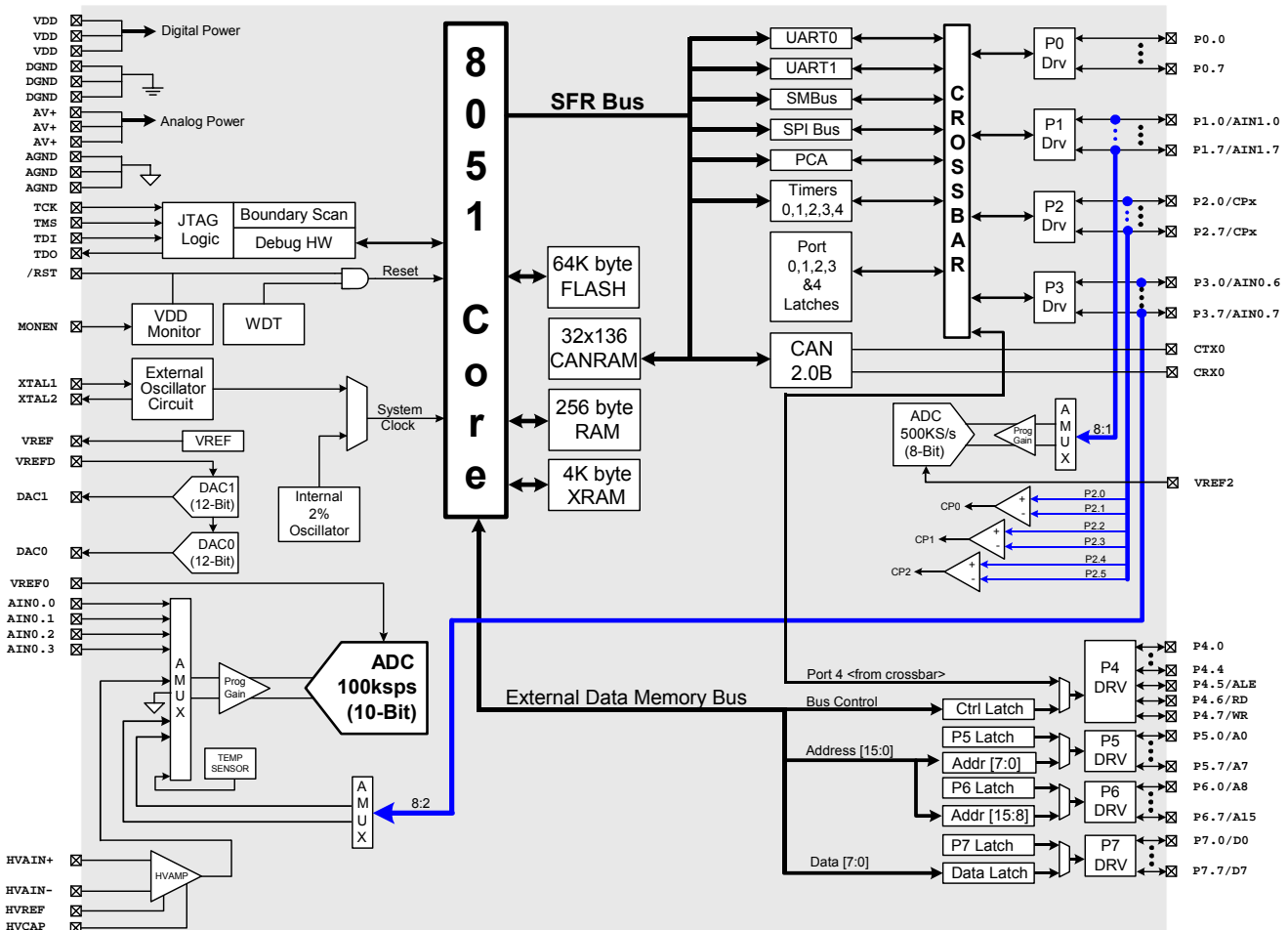

SELECTED ELECTRICAL SPECIFICATIONS $T_A = -40^{\circ}\text{C}$ to $+85^{\circ}\text{C}$, $V_{DD} = 2.7\text{V}$ unless otherwise specified.

PARAMETER	CONDITIONS	MIN	TYP	MAX	UNITS
GLOBAL CHARACTERISTICS					
Supply Voltage		2.7		3.6	V
Supply Current (CPU active)	Clock=25MHz		10		mA
	Clock=1MHz		0.5		mA
	Clock=32kHz; VDD Monitor Enabled		20		μA
Supply Current (shutdown)	Oscillator not running; VDD Monitor Disabled		0.1		μA
Clock Frequency Range		DC		25	MHz
A/D CONVERTER					
Resolution			10		bits
Integral Nonlinearity				± 1	LSB
Differential Nonlinearity	Guaranteed Monotonic			± 1	LSB
Signal-to-Noise Plus Distortion		59			dB
Throughput Rate				100	ksp/s
Input Voltage Range		0		VREF	V
D/A CONVERTERS					
Resolution			12		LSB
Differential Nonlinearity				± 1	LSB
Output Settling Time			10		μs
COMPARATORS					
Supply Current	(each Comparator)		1.5		μA
Response Time	$ CP+ - CP- = 100\text{mV}$		4		μs

