

# XMC1200

Microcontroller Series  
for Industrial Applications

XMC1000 Family

ARM<sup>®</sup> Cortex<sup>™</sup> -M0  
32-bit processor core

Reference Manual

V1.0 2013-03

Microcontrollers

**Edition 2013-03**

**Published by  
Infineon Technologies AG  
81726 Munich, Germany**

**© 2013 Infineon Technologies AG  
All Rights Reserved.**

#### **Legal Disclaimer**

The information given in this document shall in no event be regarded as a guarantee of conditions or characteristics. With respect to any examples or hints given herein, any typical values stated herein and/or any information regarding the application of the device, Infineon Technologies hereby disclaims any and all warranties and liabilities of any kind, including without limitation, warranties of non-infringement of intellectual property rights of any third party.

#### **Information**

For further information on technology, delivery terms and conditions and prices, please contact the nearest Infineon Technologies Office ([www.infineon.com](http://www.infineon.com)).

#### **Warnings**

Due to technical requirements, components may contain dangerous substances. For information on the types in question, please contact the nearest Infineon Technologies Office.

Infineon Technologies components may be used in life-support devices or systems only with the express written approval of Infineon Technologies, if a failure of such components can reasonably be expected to cause the failure of that life-support device or system or to affect the safety or effectiveness of that device or system. Life support devices or systems are intended to be implanted in the human body or to support and/or maintain and sustain and/or protect human life. If they fail, it is reasonable to assume that the health of the user or other persons may be endangered.

# XMC1200

Microcontroller Series  
for Industrial Applications

XMC1000 Family

ARM<sup>®</sup> Cortex<sup>™</sup>-M0  
32-bit processor core

Reference Manual

V1.0 2013-03

---

## **XMC1200 Reference Manual**

---

### **Revision History: V1.0 2013-03**

Previous Versions:

none

---

Page	Subjects

---

### **Trademarks**

C166™, TriCore™ and DAVE™ are trademarks of Infineon Technologies AG.

ARM®, ARM Powered® and AMBA® are registered trademarks of ARM, Limited.

Cortex™, CoreSight™, ETM™, Embedded Trace Macrocell™ and Embedded Trace Buffer™ are trademarks of ARM, Limited.

#### **We Listen to Your Comments**

Is there any information in this document that you feel is wrong, unclear or missing?

Your feedback will help us to continuously improve the quality of this document.

Please send your proposal (including a reference to this document) to:

[mcdocu.comments@infineon.com](mailto:mcdocu.comments@infineon.com)



## Table of Contents

<b>1</b>	<b>Introduction</b>	1-1
1.1	Overview	1-1
1.1.1	Block Diagram	1-3
1.2	Core Processing Units	1-3
1.2.1	Central Processing Unit (CPU)	1-4
1.2.2	Programmable Multiple Priority Interrupt System (NVIC)	1-4
1.3	System Units	1-4
1.3.1	Memories	1-4
1.3.2	Watchdog Timer (WDT)	1-4
1.3.3	Real Timer Clock (RTC)	1-5
1.3.4	System Control unit (SCU)	1-5
1.3.5	Pseudo Random Bit Generator (PRNG)	1-5
1.4	Peripherals Units	1-5
1.5	Debug Unit	1-7
<b>2</b>	<b>Central Processing Unit (CPU)</b>	2-1
2.1	Overview	2-1
2.1.1	Features	2-2
2.1.2	Block Diagram	2-2
2.2	Programmers Model	2-3
2.2.1	Processor Mode	2-3
2.2.2	Stacks	2-3
2.2.3	Core Registers	2-5
2.2.4	Exceptions and Interrupts	2-15
2.2.5	Data Types	2-15
2.2.6	The Cortex Microcontroller Software Interface Standard	2-15
2.2.7	CMSIS Functions	2-16
2.3	Memory Model	2-18
2.3.1	Memory Regions, Types and Attributes	2-19
2.3.2	Memory System Ordering of Memory Accesses	2-19
2.3.3	Behavior of Memory Accesses	2-20
2.3.4	Software Ordering of Memory Accesses	2-21
2.3.5	Memory Endianness	2-22
2.3.5.1	Little-endian format	2-22
2.4	Instruction Set	2-23
2.4.1	Intrinsic Functions	2-25
2.5	Exception Model	2-26
2.5.1	Exception States	2-26
2.5.2	Exception Types	2-27
2.5.3	Exception Handlers	2-28
2.5.4	Vector Table	2-28

**Table of Contents**

2.5.4.1	Vector Table Remap .....	2-29
2.5.5	Exception Priorities .....	2-30
2.5.6	Exception Entry and Return .....	2-31
2.5.6.1	Exception entry .....	2-32
2.5.6.2	Exception return .....	2-34
2.6	Fault Handling .....	2-35
2.6.1	Lockup .....	2-35
2.7	Power Management .....	2-36
2.7.1	Entering Sleep Mode .....	2-36
2.7.2	Wakeup from Sleep Mode .....	2-37
2.7.3	Power Management Programming Hints .....	2-37
2.8	Private Peripherals .....	2-38
2.8.1	About the Private Peripherals .....	2-38
2.8.2	System control block .....	2-38
2.8.2.1	System control block usage hints and tips .....	2-38
2.8.3	System timer, SysTick .....	2-38
2.8.3.1	SysTick usage hints and tips .....	2-39
2.9	PPB Registers .....	2-40
2.9.1	SCS Registers .....	2-41
2.9.2	SysTick Registers .....	2-52
<b>3</b>	<b>Bus System .....</b>	<b>3-1</b>
3.1	Bus Interfaces .....	3-1
<b>4</b>	<b>Service Request Processing .....</b>	<b>4-1</b>
4.1	Overview .....	4-1
4.1.1	Features .....	4-1
4.1.2	Block Diagram .....	4-1
4.2	Service Request Distribution .....	4-3
<b>5</b>	<b>Interrupt Subsystem .....</b>	<b>5-1</b>
5.1	Nested Vectored Interrupt Controller (NVIC) .....	5-1
5.1.1	Features .....	5-1
5.1.2	Interrupt Node Assignment .....	5-1
5.1.3	Interrupt Signal Generation .....	5-2
5.1.4	NVIC design hints and tips .....	5-3
5.1.5	Accessing CPU Registers using CMSIS .....	5-4
5.1.6	Interrupt Priority .....	5-4
5.1.7	Interrupt Response Time .....	5-5
5.2	General Module Interrupt Structure .....	5-6
5.3	Registers .....	5-8
5.3.1	NVIC Registers .....	5-9
5.4	Interrupt Request Source Overview .....	5-13
<b>6</b>	<b>Event Request Unit (ERU) .....</b>	<b>6-1</b>

**Table of Contents**

6.1	Features .....	6-1
6.2	Overview .....	6-1
6.3	Event Request Select Unit (ERS) .....	6-2
6.4	Event Trigger Logic (ETLx) .....	6-3
6.5	Cross Connect Matrix .....	6-4
6.6	Output Gating Unit (OGUy) .....	6-5
6.7	Power, Reset and Clock .....	6-8
6.8	Initialization and System Dependencies .....	6-9
6.9	Registers .....	6-10
6.9.1	ERU Registers .....	6-11
6.10	Interconnects .....	6-16
6.10.1	ERU0 Connections .....	6-17
<b>7</b>	<b>Memory Organization .....</b>	<b>7-1</b>
7.1	Overview .....	7-1
7.1.1	Features .....	7-1
7.2	Memory Map .....	7-1
7.3	Memory Access .....	7-8
7.3.1	Flash Memory Access .....	7-8
7.3.2	SRAM Access .....	7-8
7.3.3	ROM Access .....	7-8
7.4	Memory Protection Strategy .....	7-8
7.4.1	Intellectual Property (IP) Protection .....	7-9
7.4.1.1	Blocking of Unauthorized External Access .....	7-9
7.4.2	Memory Access Protection during Run-time .....	7-9
7.4.2.1	Bit Protection Scheme .....	7-9
7.4.2.2	Peripheral Privilege Access Control .....	7-11
<b>8</b>	<b>Flash Architecture .....</b>	<b>8-1</b>
8.1	Definitions .....	8-1
8.1.1	Logical and Physical States .....	8-2
8.1.2	Data Portions .....	8-2
8.1.3	Address Types .....	8-2
8.1.4	Module Specific Definitions .....	8-3
8.2	Module Components .....	8-3
8.2.1	Memory Cell Array .....	8-3
8.2.1.1	Page .....	8-4
8.2.1.2	Sector .....	8-4
8.3	Functional Description .....	8-5
8.3.1	SFR Accesses .....	8-5
8.3.2	Memory Read .....	8-5
8.3.3	Memory Write .....	8-5
8.3.4	Memory Erase .....	8-6
8.3.5	Verify .....	8-6

**Table of Contents**

8.3.6	Erase-Protection and Write-Protection	8-7
8.4	Redundancy	8-7
8.5	Power Saving Modes	8-7
8.5.1	Idle Mode	8-7
8.5.2	Sleep Mode	8-8
8.6	Properties and Implementation of Error Correcting Code (ECC)	8-8
8.7	NVM SFRs	8-9
8.7.1	Register Descriptions	8-10
8.8	Example Sequences	8-17
8.8.1	Writing to Memory	8-17
8.8.1.1	Writing a Single Block	8-17
8.8.1.2	Writing Blocks	8-17
8.8.2	Erasing Memory	8-18
8.8.2.1	Erasing a Single Page	8-18
8.8.2.2	Erasing Pages	8-18
8.8.3	Verifying Memory	8-18
8.8.3.1	Verifying a Single Block	8-19
8.8.3.2	Verifying Blocks	8-19
8.8.4	Writing to an Already Written Block	8-19
8.8.5	Sleep Mode	8-21
8.8.6	Timing	8-22
<b>9</b>	<b>Peripheral Access Unit (PAU)</b>	<b>9-1</b>
9.1	Features	9-1
9.2	Peripheral Privilege Access Control	9-1
9.3	Peripheral Availability and Memory Size	9-2
9.4	PAU Registers	9-3
9.4.1	Peripheral Privilege Access Registers (PRIVDISn)	9-4
9.4.2	Peripheral Availability Registers (AVAILn)	9-7
9.4.3	Memory Size Registers	9-10
<b>10</b>	<b>Window Watchdog Timer (WDT)</b>	<b>10-1</b>
10.1	Overview	10-1
10.1.1	Features	10-1
10.1.2	Block Diagram	10-2
10.2	Time-Out Mode	10-3
10.3	Pre-warning Mode	10-3
10.4	Bad Service Operation	10-4
10.5	Service Request Processing	10-6
10.6	Debug Behavior	10-6
10.7	Power, Reset and Clock	10-6
10.8	Initialization and Control Sequence	10-6
10.8.1	Initialization & Start of Operation	10-6
10.8.2	Software Stop & Resume Operation	10-7



**Table of Contents**

10.8.3	Enter Sleep/Deep-Sleep & Resume Operation	10-7
10.8.4	Pre-warning Alarm Handling	10-8
10.9	WDT Registers	10-9
10.9.1	Registers Description	10-9
10.10	Interconnects	10-16
<b>11</b>	<b>Real Time Clock (RTC)</b>	<b>11-1</b>
11.1	Overview	11-1
11.1.1	Features	11-1
11.1.2	Block Diagram	11-1
11.2	RTC Operation	11-2
11.3	Register Access Operations	11-3
11.4	Service Request Processing	11-4
11.4.1	Periodic Service Request	11-4
11.4.2	Timer Alarm Service Request	11-4
11.5	Debug Behavior	11-4
11.6	Power, Reset and Clock	11-4
11.7	Initialization and Control Sequence	11-5
11.7.1	Initialization & Start of Operation	11-5
11.7.2	Configure and Enable Periodic Event	11-6
11.7.3	Configure and Enable Timer Event	11-6
11.8	RTC Registers	11-6
11.8.1	Registers Description	11-7
11.9	Interconnects	11-18
<b>12</b>	<b>System Control Unit (SCU)</b>	<b>12-1</b>
12.1	Overview	12-1
12.1.1	Features	12-1
12.1.2	Block Diagram	12-2
12.2	Miscellaneous Control Functions (GCU)	12-4
12.2.1	Service Requests Handling	12-4
12.2.1.1	Service Request Sources	12-4
12.2.2	SRAM Memory Content Protection	12-6
12.2.3	Summary of ID	12-6
12.3	Power Management (PCU)	12-8
12.3.1	Functional Description	12-8
12.3.2	System States	12-8
12.3.3	Embedded Voltage Regulator (EVR)	12-10
12.3.4	Power-on Reset	12-10
12.3.5	Power Validation	12-10
12.3.6	Supply Voltage Monitoring	12-10
12.3.7	V <sub>D</sub> DC Response During Load Change	12-11
12.3.8	Flash Power Control	12-12
12.4	Reset Control (RCU)	12-13

**Table of Contents**

12.4.1	Functional Description	12-13
12.4.2	Reset Status	12-14
12.5	Clock Control (CCU)	12-15
12.5.1	Features	12-15
12.5.2	Clock System and Control	12-15
12.5.2.1	Oscillator Watchdog	12-18
12.5.2.2	Loss of Clock Detection and Recovery	12-18
12.5.2.3	Standby Clock Failure	12-19
12.5.2.4	Startup Control for System Clock	12-19
12.5.3	Clock Gating Control	12-19
12.5.4	Calibrating DCO based on Temperature	12-20
12.6	Service Request Generation	12-20
12.7	Debug Behavior	12-21
12.8	Power, Reset and Clock	12-21
12.9	Registers	12-22
12.9.1	PCU Registers (ANACTRL)	12-24
12.9.2	PCU Registers (SCU)	12-25
12.9.3	CCU Registers (SCU)	12-26
12.9.4	CCU Registers (ANACTRL)	12-34
12.9.5	RCU Registers (SCU)	12-35
12.9.6	GCU Registers (SCU)	12-40
<b>13</b>	<b>Pseudo Random Number Generator</b>	<b>13-1</b>
13.1	Introduction	13-1
13.2	Description of Operation Modes	13-2
13.2.1	Key Loading Mode	13-2
13.2.2	Streaming Mode	13-2
13.2.3	Refreshing and Restarting a Random Bit Stream	13-3
13.3	Debug Behavior	13-3
13.4	PRNG Registers	13-4
13.4.1	Data SFRs	13-4
13.4.2	Control SFRs	13-7
<b>14</b>	<b>LED and Touch-Sense (LEDTS)</b>	<b>14-1</b>
14.1	Overview	14-1
14.1.1	Features	14-1
14.1.2	Block Diagram	14-2
14.2	Functional Overview	14-4
14.3	LED Drive Mode	14-7
14.3.1	LED Pin Assignment and Current Capability	14-9
14.4	Touch-Sense Mode	14-10
14.4.1	Finger Sensing	14-15
14.5	Operating both LED Drive and Touch-Sense Modes	14-17
14.6	Service Request Processing	14-18

**Table of Contents**

14.7	Debug Behavior .....	14-19
14.8	Power, Reset and Clock .....	14-19
14.9	Initialisation and System Dependencies .....	14-19
14.9.1	Function Enabling .....	14-19
14.9.2	Interpretation of Bit Field FNCOL .....	14-21
14.9.3	LEDTS Timing Calculations .....	14-22
14.9.4	Time-Multiplexed LED and Touch-Sense Functions on Pin .....	14-22
14.9.5	LEDTS Pin Control .....	14-23
14.9.6	Software Hints .....	14-26
14.9.7	Hardware Design Hints .....	14-27
14.10	Multiple Kernels Usage and Synchronization .....	14-27
14.11	Registers .....	14-30
14.11.1	Registers Description .....	14-31
14.12	Interconnects .....	14-44
<b>15</b>	<b>Universal Serial Interface Channel (USIC) .....</b>	<b>15-1</b>
15.1	Overview .....	15-1
15.1.1	Features .....	15-1
15.2	Operating the USIC .....	15-5
15.2.1	USIC Structure Overview .....	15-5
15.2.1.1	Channel Structure .....	15-5
15.2.1.2	Input Stages .....	15-5
15.2.1.3	Output Signals .....	15-7
15.2.1.4	Baud Rate Generator .....	15-8
15.2.1.5	Channel Events and Interrupts .....	15-9
15.2.1.6	Data Shifting and Handling .....	15-9
15.2.2	Operating the USIC Communication Channel .....	15-13
15.2.2.1	Protocol Control and Status .....	15-14
15.2.2.2	Mode Control .....	15-15
15.2.2.3	General Channel Events and Interrupts .....	15-16
15.2.2.4	Data Transfer Events and Interrupts .....	15-17
15.2.2.5	Baud Rate Generator Event and Interrupt .....	15-19
15.2.2.6	Protocol-specific Events and Interrupts .....	15-21
15.2.3	Operating the Input Stages .....	15-21
15.2.3.1	General Input Structure .....	15-22
15.2.3.2	Digital Filter .....	15-24
15.2.3.3	Edge Detection .....	15-24
15.2.3.4	Selected Input Monitoring .....	15-25
15.2.3.5	Loop Back Mode .....	15-25
15.2.4	Operating the Baud Rate Generator .....	15-25
15.2.4.1	Fractional Divider .....	15-25
15.2.4.2	External Frequency Input .....	15-26
15.2.4.3	Divider Mode Counter .....	15-26

**Table of Contents**

15.2.4.4	Capture Mode Timer .....	15-27
15.2.4.5	Time Quanta Counter .....	15-28
15.2.4.6	Master and Shift Clock Output Configuration .....	15-29
15.2.5	Operating the Transmit Data Path .....	15-30
15.2.5.1	Transmit Buffering .....	15-30
15.2.5.2	Transmit Data Shift Mode .....	15-31
15.2.5.3	Transmit Control Information .....	15-32
15.2.5.4	Transmit Data Validation .....	15-33
15.2.6	Operating the Receive Data Path .....	15-35
15.2.6.1	Receive Buffering .....	15-35
15.2.6.2	Receive Data Shift Mode .....	15-36
15.2.6.3	Baud Rate Constraints .....	15-37
15.2.7	Hardware Port Control .....	15-37
15.2.8	Operating the FIFO Data Buffer .....	15-38
15.2.8.1	FIFO Buffer Partitioning .....	15-39
15.2.8.2	Transmit Buffer Events and Interrupts .....	15-40
15.2.8.3	Receive Buffer Events and Interrupts .....	15-44
15.2.8.4	FIFO Buffer Bypass .....	15-49
15.2.8.5	FIFO Access Constraints .....	15-50
15.2.8.6	Handling of FIFO Transmit Control Information .....	15-51
15.3	Asynchronous Serial Channel (ASC = UART) .....	15-53
15.3.1	Signal Description .....	15-53
15.3.2	Frame Format .....	15-54
15.3.2.1	Idle Time .....	15-55
15.3.2.2	Start Bit Detection .....	15-56
15.3.2.3	Data Field .....	15-56
15.3.2.4	Parity Bit .....	15-56
15.3.2.5	Stop Bit(s) .....	15-56
15.3.3	Operating the ASC .....	15-57
15.3.3.1	Bit Timing .....	15-57
15.3.3.2	Baud Rate Generation .....	15-58
15.3.3.3	Noise Detection .....	15-59
15.3.3.4	Collision Detection .....	15-59
15.3.3.5	Pulse Shaping .....	15-59
15.3.3.6	Automatic Shadow Mechanism .....	15-61
15.3.3.7	End of Frame Control .....	15-61
15.3.3.8	Mode Control Behavior .....	15-62
15.3.3.9	Disabling ASC Mode .....	15-62
15.3.3.10	Protocol Interrupt Events .....	15-62
15.3.3.11	Data Transfer Interrupt Handling .....	15-63
15.3.3.12	Baud Rate Generator Interrupt Handling .....	15-63
15.3.3.13	Protocol-Related Argument and Error .....	15-64
15.3.3.14	Receive Buffer Handling .....	15-64

**Table of Contents**

15.3.3.15	Sync-Break Detection .....	15-64
15.3.3.16	Transfer Status Indication .....	15-64
15.3.4	ASC Protocol Registers .....	15-65
15.3.4.1	ASC Protocol Control Register .....	15-65
15.3.4.2	ASC Protocol Status Register .....	15-68
15.3.5	Hardware LIN Support .....	15-71
15.4	Synchronous Serial Channel (SSC) .....	15-73
15.4.1	Signal Description .....	15-73
15.4.1.1	Transmit and Receive Data Signals .....	15-75
15.4.1.2	Shift Clock Signals .....	15-76
15.4.1.3	Slave Select Signals .....	15-79
15.4.2	Operating the SSC .....	15-81
15.4.2.1	Automatic Shadow Mechanism .....	15-81
15.4.2.2	Mode Control Behavior .....	15-81
15.4.2.3	Disabling SSC Mode .....	15-82
15.4.2.4	Data Frame Control .....	15-82
15.4.2.5	Parity Mode .....	15-82
15.4.2.6	Transfer Mode .....	15-84
15.4.2.7	Data Transfer Interrupt Handling .....	15-84
15.4.2.8	Baud Rate Generator Interrupt Handling .....	15-85
15.4.2.9	Protocol-Related Argument and Error .....	15-85
15.4.2.10	Receive Buffer Handling .....	15-85
15.4.2.11	Multi-IO SSC Protocols .....	15-85
15.4.3	Operating the SSC in Master Mode .....	15-87
15.4.3.1	Baud Rate Generation .....	15-88
15.4.3.2	MSLS Generation .....	15-89
15.4.3.3	Automatic Slave Select Update .....	15-90
15.4.3.4	Slave Select Delay Generation .....	15-91
15.4.3.5	Protocol Interrupt Events .....	15-92
15.4.3.6	End-of-Frame Control .....	15-93
15.4.4	Operating the SSC in Slave Mode .....	15-95
15.4.4.1	Protocol Interrupts .....	15-95
15.4.4.2	End-of-Frame Control .....	15-96
15.4.5	SSC Protocol Registers .....	15-97
15.4.5.1	SSC Protocol Control Registers .....	15-97
15.4.5.2	SSC Protocol Status Register .....	15-101
15.4.6	SSC Timing Considerations .....	15-103
15.4.6.1	Closed-loop Delay .....	15-103
15.4.6.2	Delay Compensation in Master Mode .....	15-106
15.4.6.3	Complete Closed-loop Delay Compensation .....	15-107
15.5	Inter-IC Bus Protocol (IIC) .....	15-108
15.5.1	Introduction .....	15-108
15.5.1.1	Signal Description .....	15-108

**Table of Contents**

15.5.1.2	Symbols .....	15-109
15.5.1.3	Frame Format .....	15-110
15.5.2	Operating the IIC .....	15-111
15.5.2.1	Transmission Chain .....	15-112
15.5.2.2	Byte Stretching .....	15-112
15.5.2.3	Master Arbitration .....	15-112
15.5.2.4	Non-Acknowledge and Error Conditions .....	15-113
15.5.2.5	Mode Control Behavior .....	15-113
15.5.2.6	Data Transfer Interrupt Handling .....	15-113
15.5.2.7	IIC Protocol Interrupt Events .....	15-114
15.5.2.8	Baud Rate Generator Interrupt Handling .....	15-115
15.5.2.9	Receiver Address Acknowledge .....	15-115
15.5.2.10	Receiver Handling .....	15-116
15.5.2.11	Receiver Status Information .....	15-116
15.5.3	Symbol Timing .....	15-117
15.5.3.1	Start Symbol .....	15-118
15.5.3.2	Repeated Start Symbol .....	15-118
15.5.3.3	Stop Symbol .....	15-119
15.5.3.4	Data Bit Symbol .....	15-119
15.5.4	Data Flow Handling .....	15-120
15.5.4.1	Transmit Data Formats .....	15-120
15.5.4.2	Valid Master Transmit Data Formats .....	15-122
15.5.4.3	Master Transmit/Receive Modes .....	15-125
15.5.4.4	Slave Transmit/Receive Modes .....	15-127
15.5.5	IIC Protocol Registers .....	15-128
15.5.5.1	IIC Protocol Control Registers .....	15-128
15.5.5.2	IIC Protocol Status Register .....	15-131
15.6	Inter-IC Sound Bus Protocol (IIS) .....	15-134
15.6.1	Introduction .....	15-134
15.6.1.1	Signal Description .....	15-134
15.6.1.2	Protocol Overview .....	15-135
15.6.1.3	Transfer Delay .....	15-136
15.6.1.4	Connection of External Audio Components .....	15-136
15.6.2	Operating the IIS .....	15-137
15.6.2.1	Frame Length and Word Length Configuration .....	15-137
15.6.2.2	Automatic Shadow Mechanism .....	15-138
15.6.2.3	Mode Control Behavior .....	15-138
15.6.2.4	Transfer Delay .....	15-138
15.6.2.5	Parity Mode .....	15-140
15.6.2.6	Transfer Mode .....	15-140
15.6.2.7	Data Transfer Interrupt Handling .....	15-140
15.6.2.8	Baud Rate Generator Interrupt Handling .....	15-141
15.6.2.9	Protocol-Related Argument and Error .....	15-141

**Table of Contents**

15.6.2.10	Transmit Data Handling .....	15-141
15.6.2.11	Receive Buffer Handling .....	15-142
15.6.2.12	Loop-Delay Compensation .....	15-142
15.6.3	Operating the IIS in Master Mode .....	15-142
15.6.3.1	Baud Rate Generation .....	15-143
15.6.3.2	WA Generation .....	15-144
15.6.3.3	Master Clock Output .....	15-144
15.6.3.4	Protocol Interrupt Events .....	15-145
15.6.4	Operating the IIS in Slave Mode .....	15-146
15.6.4.1	Protocol Events and Interrupts .....	15-146
15.6.5	IIS Protocol Registers .....	15-147
15.6.5.1	IIS Protocol Control Registers .....	15-147
15.6.5.2	IIS Protocol Status Register .....	15-149
15.7	Service Request Generation .....	15-153
15.8	Debug Behaviour .....	15-153
15.9	Power, Reset and Clock .....	15-153
15.10	Initialization and System Dependencies .....	15-153
15.11	Registers .....	15-153
15.11.1	Address Map .....	15-157
15.11.2	Module Identification Registers .....	15-157
15.11.3	Channel Control and Configuration Registers .....	15-158
15.11.3.1	Channel Control Register .....	15-158
15.11.3.2	Channel Configuration Register .....	15-163
15.11.3.3	Kernel State Configuration Register .....	15-164
15.11.3.4	Interrupt Node Pointer Register .....	15-167
15.11.4	Protocol Related Registers .....	15-168
15.11.4.1	Protocol Control Registers .....	15-168
15.11.4.2	Protocol Status Register .....	15-169
15.11.4.3	Protocol Status Clear Register .....	15-170
15.11.5	Input Stage Register .....	15-171
15.11.5.1	Input Control Registers .....	15-171
15.11.6	Baud Rate Generator Registers .....	15-177
15.11.6.1	Fractional Divider Register .....	15-177
15.11.6.2	Baud Rate Generator Register .....	15-178
15.11.6.3	Capture Mode Timer Register .....	15-181
15.11.7	Transfer Control and Status Registers .....	15-181
15.11.7.1	Shift Control Register .....	15-181
15.11.7.2	Transmission Control and Status Register .....	15-185
15.11.7.3	Flag Modification Registers .....	15-191
15.11.8	Data Buffer Registers .....	15-193
15.11.8.1	Transmit Buffer Locations .....	15-193
15.11.8.2	Receive Buffer Registers RBUF0, RBUF1 .....	15-194
15.11.8.3	Receive Buffer Registers RBUF, RBUFD, RBUFSR .....	15-200

**Table of Contents**

15.11.9	FIFO Buffer and Bypass Registers .....	15-204
15.11.9.1	Bypass Registers .....	15-204
15.11.9.2	General FIFO Buffer Control Registers .....	15-207
15.11.9.3	Transmit FIFO Buffer Control Registers .....	15-213
15.11.9.4	Receive FIFO Buffer Control Registers .....	15-217
15.11.9.5	FIFO Buffer Data Registers .....	15-222
15.11.9.6	FIFO Buffer Pointer Registers .....	15-225
15.12	Interconnects .....	15-226
15.12.1	USIC Module 0 Interconnects .....	15-227
<b>16</b>	<b>Versatile Analog-to-Digital Converter (VADC) .....</b>	<b>16-1</b>
16.1	Overview .....	16-1
16.2	Introduction and Basic Structure .....	16-4
16.3	Electrical Models .....	16-9
16.4	Configuration of General Functions .....	16-12
16.4.1	General Clocking Scheme and Control .....	16-12
16.4.2	Register Access Control .....	16-12
16.4.3	Priority Channel and Result Register Assignment .....	16-13
16.5	Analog Module Activation and Control .....	16-14
16.5.1	Analog Converter Control .....	16-14
16.5.2	Calibration .....	16-15
16.5.3	Sigma-Delta-Loop Function .....	16-16
16.6	Conversion Request Generation .....	16-17
16.6.1	Queued Request Source Handling .....	16-19
16.6.2	Channel Scan Request Source Handling .....	16-22
16.7	Request Source Arbitration .....	16-26
16.7.1	Arbiter Operation and Configuration .....	16-27
16.7.2	Conversion Start Mode .....	16-28
16.8	Analog Input Channel Configuration .....	16-30
16.8.1	Channel Parameters .....	16-30
16.8.2	Alias Feature .....	16-31
16.8.3	Conversion Modes .....	16-32
16.8.4	Compare with Standard Conversions (Limit Checking) .....	16-33
16.8.5	Utilizing Fast Compare Mode .....	16-34
16.8.6	Boundary Flag Control .....	16-36
16.9	Conversion Scheduling .....	16-37
16.10	Conversion Timing .....	16-39
16.10.1	Compatible Timing Mode .....	16-39
16.10.2	Accelerated Timing Mode .....	16-40
16.11	Conversion Result Handling .....	16-42
16.11.1	Storage of Conversion Results .....	16-42
16.11.2	Data Alignment .....	16-44
16.11.3	Wait-for-Read Mode .....	16-45



**Table of Contents**

16.11.4	Result FIFO Buffer .....	16-46
16.11.5	Result Event Generation .....	16-47
16.11.6	Data Modification .....	16-47
16.12	Synchronization of Conversions .....	16-54
16.12.1	Synchronized Conversions for Parallel Sampling .....	16-54
16.12.2	Equidistant Sampling .....	16-57
16.13	Safety Features .....	16-58
16.13.1	Broken Wire Detection .....	16-58
16.13.2	Multiplexer Diagnostics .....	16-59
16.14	External Multiplexer Control .....	16-60
16.15	Service Request Generation .....	16-62
16.16	Registers .....	16-64
16.16.1	Module Identification .....	16-69
16.16.2	System Registers .....	16-70
16.16.3	General Registers .....	16-73
16.16.4	Arbitration and Source Registers .....	16-84
16.16.5	Channel Control Registers .....	16-112
16.16.6	Result Registers .....	16-117
16.16.7	Calbration Registers .....	16-125
16.16.8	Miscellaneous Registers .....	16-128
16.16.9	Service Request Registers .....	16-140
16.17	Interconnects .....	16-151
16.17.1	Product-Specific Configuration .....	16-151
16.17.2	Analog Module Connections in the XMC1200 .....	16-153
16.17.3	Digital Module Connections in the XMC1200 .....	16-154
<b>17</b>	<b>Analog Comparator (ACMP) and Out of Range Comparator (ORC)</b> .....	<b>17-1</b>
17.1	Overview .....	17-1
17.1.1	Features .....	17-1
17.2	Analog Comparator (ACMP) .....	17-1
17.3	Out of Range Comparator (ORC) .....	17-3
17.4	Service Request Generation .....	17-4
17.5	Debug Behavior .....	17-4
17.6	Registers .....	17-4
17.6.1	ORC Register .....	17-5
17.6.2	ACMP Registers .....	17-6
17.7	Interconnects .....	17-12
<b>18</b>	<b>Temperature Sensor (TSE)</b> .....	<b>18-1</b>
18.1	General Description .....	18-1
18.2	Service Request Generation .....	18-1
18.3	Registers .....	18-1
18.3.1	Registers .....	18-2

**Table of Contents**

<b>19</b>	<b>Capture/Compare Unit 4 (CCU4)</b>	<b>19-1</b>
19.1	Overview	19-1
19.1.1	Features	19-2
19.1.2	Block Diagram	19-4
19.2	Functional Description	19-6
19.2.1	CC4y Overview	19-6
19.2.2	Input Selector	19-8
19.2.3	Connection Matrix	19-10
19.2.4	Starting/Stopping the Timer	19-12
19.2.5	Counting Modes	19-13
19.2.5.1	Calculating the PWM Period and Duty Cycle	19-14
19.2.5.2	Updating the Period and Duty Cycle	19-15
19.2.5.3	Edge Aligned Mode	19-19
19.2.5.4	Center Aligned Mode	19-20
19.2.5.5	Single Shot Mode	19-21
19.2.6	Active/Passive Rules	19-22
19.2.7	External Events Control	19-22
19.2.7.1	External Start/Stop	19-23
19.2.7.2	External Counting Direction	19-25
19.2.7.3	External Gating Signal	19-27
19.2.7.4	External Count Signal	19-27
19.2.7.5	External Load	19-28
19.2.7.6	External Capture	19-29
19.2.7.7	Capture Extended Read Back Mode	19-35
19.2.7.8	External Modulation	19-38
19.2.7.9	TRAP Function	19-41
19.2.7.10	Status Bit Override	19-43
19.2.8	Multi-Channel Control	19-44
19.2.9	Timer Concatenation	19-47
19.2.10	PWM Dithering	19-52
19.2.11	Prescaler	19-57
19.2.11.1	Normal Prescaler Mode	19-58
19.2.11.2	Floating Prescaler Mode	19-58
19.2.12	CCU4 Usage	19-60
19.2.12.1	PWM Signal Generation	19-60
19.2.12.2	Prescaler Usage	19-62
19.2.12.3	PWM Dither	19-64
19.2.12.4	Capture Mode Usage	19-67
19.3	Service Request Generation	19-73
19.4	Debug Behavior	19-77
19.5	Power, Reset and Clock	19-77
19.5.1	Clocks	19-77
19.5.2	Power	19-78

**Table of Contents**

19.6	Initialization and System Dependencies .....	19-78
19.6.1	Initialization Sequence .....	19-79
19.6.2	System Dependencies .....	19-79
19.7	Registers .....	19-80
19.7.1	Global Registers .....	19-86
19.7.2	Slice (CC4y) Registers .....	19-101
19.8	Interconnects .....	19-137
19.8.1	CCU40 pins .....	19-137
<b>20</b>	<b>Brightness and Color Control Unit (BCCU) .....</b>	<b>20-1</b>
20.1	Overview .....	20-1
20.1.1	Features .....	20-1
20.2	Functional Description .....	20-1
20.2.1	Channel Structure .....	20-2
20.2.2	Exponential Dimming .....	20-3
20.2.3	Linear Color Walk .....	20-13
20.2.4	Sigma-Delta Modulator .....	20-14
20.2.5	Packer .....	20-14
20.2.6	Global Trigger Control .....	20-15
20.2.7	Trap Control .....	20-17
20.3	Power, Reset and Clock .....	20-18
20.4	Service Request Generation .....	20-19
20.5	Debug Behaviour .....	20-20
20.6	Initialization .....	20-20
20.7	Digital-to-Analog Converter .....	20-21
20.8	Registers .....	20-23
20.8.1	Global Registers .....	20-25
20.8.2	Channel Registers .....	20-40
20.8.3	Dimming Engine Registers .....	20-45
20.9	Interconnects .....	20-48
<b>21</b>	<b>General Purpose I/O Ports (Ports) .....</b>	<b>21-1</b>
21.1	Overview .....	21-1
21.1.1	Features .....	21-1
21.1.2	Block Diagram .....	21-2
21.1.3	Definition of Terms .....	21-3
21.2	GPIO and Alternate Functions .....	21-3
21.2.1	Input Operation .....	21-4
21.2.2	Output Operation .....	21-4
21.3	Hardware Controlled I/Os .....	21-5
21.4	Power Saving Mode Operation .....	21-6
21.5	Analog Ports .....	21-7
21.6	Power, Reset and Clock .....	21-8
21.7	Initialization and System Dependencies .....	21-9

**Table of Contents**

21.8	Registers .....	21-11
21.8.1	Port Input/Output Control Registers .....	21-14
21.8.2	Pad Hysteresis Control Register .....	21-18
21.8.3	Pin Function Decision Control Register .....	21-23
21.8.4	Port Output Register .....	21-28
21.8.5	Port Output Modification Register .....	21-31
21.8.6	Port Input Register .....	21-34
21.8.7	Port Pin Power Save Register .....	21-36
21.8.8	Port Pin Hardware Select Register .....	21-39
21.9	Package Pin Summary .....	21-42
21.10	Port I/O Functions .....	21-45
21.10.1	Port Pin for Boot Modes .....	21-45
21.10.2	Port I/O Function Description .....	21-46
<b>22</b>	<b>Boot and Startup .....</b>	<b>22-1</b>
22.1	Startup Sequence and System Dependencies .....	22-2
22.1.1	Power-Up .....	22-2
22.1.2	System Reset Release .....	22-2
22.1.3	Startup Software (SSW) Execution .....	22-2
22.1.3.1	Clock system handling by SSW .....	22-3
22.1.4	Configuration of Special System Functions as part of User code initialization 22-3	
22.1.5	Configuration of Clock System and Miscellaneous Functions .....	22-4
22.2	Start-up Modes .....	22-5
22.2.1	Start-up modes in XMC1200 .....	22-5
22.2.1.1	User productive mode .....	22-5
22.2.1.2	User mode with debug enabled .....	22-6
22.2.1.3	User mode with debug enabled and Halt After Reset (HAR) .....	22-6
22.2.1.4	Standard Bootstrap Loader modes .....	22-6
22.2.1.5	Bootstrap Loader modes with time-out .....	22-6
22.2.2	Boot Mode Index (BMI) .....	22-8
22.2.3	Start-up mode selection .....	22-9
22.2.3.1	BMI handling by SSW .....	22-9
22.2.3.2	Debug system handling .....	22-10
22.3	Data in Flash for SSW and User SW .....	22-10
<b>23</b>	<b>Bootstrap Loaders (BSL) and User Routines .....</b>	<b>23-1</b>
23.1	ASC (UART) Bootstrap Loader .....	23-1
23.1.1	Pin usage .....	23-1
23.1.2	ASC BSL execution flow .....	23-1
23.1.2.1	ASC BSL entry check sequence .....	23-1
23.1.2.2	ASC BSL download sequence .....	23-6
23.1.3	ASC BSL protocol data definitions .....	23-7
23.2	SSC Bootstrap loader .....	23-9

**Table of Contents**

23.3	Firmware routines available for the user	23-11
23.3.1	Erase Flash Page	23-12
23.3.2	Erase, Program & Verify Flash Page	23-12
23.3.3	Request BMI installation	23-13
23.3.4	Calculate chip temperature	23-13
23.3.5	Calculate target level for temperature comparison	23-13
23.4	Data in Flash used by the User Routines	23-14
<b>24</b>	<b>Debug System (DBG)</b>	<b>24-1</b>
24.1	Overview	24-1
24.1.1	Features	24-2
24.1.2	Block Diagram	24-2
24.2	Debug System Operation	24-2
24.2.1	System Control Space (SCS)	24-3
24.2.2	Data Watchpoint and Trace (DWT)	24-3
24.2.3	Break Point Unit (BPU)	24-3
24.2.4	ROM Table	24-4
24.2.5	Debug tool interface access - SWD	24-4
24.2.5.1	SWD based transfers	24-4
24.2.5.2	SWD based errors	24-5
24.2.6	Debug tool interface access - Single Pin Debug (SPD)	24-6
24.2.7	Debug accesses and Flash protection	24-9
24.2.8	Halt after reset	24-9
24.2.8.1	HAR	24-9
24.2.8.2	Warm Reset	24-11
24.2.9	Halting Debug and Peripheral Suspend	24-12
24.2.10	Debug System based processor wake-up	24-14
24.2.11	Debug Access Server (DAS)	24-14
24.2.12	Debug Signals	24-15
24.2.12.1	Internal pull-up and pull-down on SWD/SPD pins	24-15
24.2.13	Reset	24-15
24.3	Debug System Power Save Operation	24-15
24.4	Service Request Generation	24-16
24.5	Debug behavior	24-16
24.6	Power, Reset and Clock	24-16
24.6.1	Power management	24-17
24.6.2	Debug System reset	24-17
24.6.3	Debug System Clocks	24-17
24.7	Initialization and System Dependencies	24-17
24.7.1	ID Codes	24-17
24.7.1.1	CPUID	24-17
24.7.1.2	ROM Table	24-18
24.8	Debug System Registers	24-19

---

**Table of Contents**

24.8.1	DFSR - Debug Fault Status Register . . . . .	24-20
24.8.2	DHCSR - Debug Halting Control and Status Register . . . . .	24-21
24.8.3	DCRSR - Debug Core Register Selector Register . . . . .	24-27
24.8.4	DCRDR - Debug Core Register Data Register . . . . .	24-29
24.8.5	DEMCR - Debug Exception and Monitor Control Register . . . . .	24-29
24.8.6	DWT_CTRL - Data Watchpoint Control Register . . . . .	24-31
24.8.7	DWT_PCSR - Program Counter Sample Register . . . . .	24-31
24.8.8	DWT_COMPx - DWT Comparator register . . . . .	24-32
24.8.9	DWT_MASKx - DWT Comparator Mask Register . . . . .	24-33
24.8.10	DWT_FUNCTIONx - Comparator Function Register . . . . .	24-34
24.8.11	BP_CTRL - Breakpoint Control Register . . . . .	24-35
24.8.12	Breakpoint Comparator Registers . . . . .	24-36

## About this Document

This Reference Manual is addressed to embedded hardware and software developers. It provides the reader with detailed descriptions about the behavior of the XMC1200 series functional units and their interaction.

The manual describes the functionality of the superset device of the XMC1200 microcontroller series. For the available functionality (features) of a specific XMC1200 derivative (derivative device), please refer to the respective Data Sheet. For simplicity, the various device types are referenced by the collective term XMC1200 throughout this manual.

### XMC1000 Family User Documentation

The set of user documentation includes:

- **Reference Manual**
  - describes the functionality of the superset device.
- **Data Sheets**
  - list the complete ordering information, available features and electrical characteristics of derivative devices.
- **Errata Sheets**
  - list deviations from the specifications given in the related Reference Manual or Data Sheets. Errata Sheets are provided for the superset of devices.

**Attention: Please consult all parts of the documentation set to attain consolidated knowledge about your device.**

Application related guidance is provided by **Users Guides** and **Application Notes**.

Please refer to <http://www.infineon.com/xmc1000> to get access to the latest versions of those documents.

### Related Documentations

The following documents are referenced:

- ARM® Cortex M0
  - Technical Reference Manual
  - User Guide, Reference Material
- ARM®v6-M Architecture Reference Manual
- AMBA® 3 AHB-Lite Protocol Specification
- AMBA® 3 APB Protocol Specification

### Copyright Notice

- Portions of CPU chapter Copyright © 2009, 2010 by ARM, Ltd. All rights reserved. Used with permission.

## Text Conventions

This document uses the following naming conventions:

- Functional units of the XMC1200 are given in plain UPPER CASE. For example: “The USIC0 unit supports...”.
- Pins using negative logic are indicated by an overline. For example: “The  $\overline{\text{WAIT}}$  input has...”.
- Bit fields and bits in registers are in general referenced as “Module\_RegisterName.BitField” or “Module\_RegisterName.Bit”. For example: “The USIC0\_PCR.MCLK bit enables the...”. Most of the register names contain a module name prefix, separated by an underscore character “\_” from the actual register name (for example, “USIC0\_PCR”, where “USIC0” is the module name prefix, and “PCR” is the kernel register name). In chapters describing the kernels of the peripheral modules, the registers are mainly referenced with their kernel register names. The peripheral module implementation sections mainly refer to the actual register names with module prefixes.
- Variables used to describe sets of processing units or registers appear in mixed upper and lower cases. For example, register name “MOFCRn” refers to multiple “MOFCR” registers with variable n. The bounds of the variables are always given where the register expression is first used (for example, “n = 0-31”), and are repeated as needed in the rest of the text.
- The default radix is decimal. Hexadecimal constants are suffixed with a subscript letter “H”, as in 100<sub>H</sub>. Binary constants are suffixed with a subscript letter “B”, as in 111<sub>B</sub>.
- When the extent of register fields, groups register bits, or groups of pins are collectively named in the body of the document, they are represented as “NAME[A:B]”, which defines a range for the named group from B to A. Individual bits, signals, or pins are given as “NAME[C]” where the range of the variable C is given in the text. For example: CFG[2:0] and SRPN[0].
- Units are abbreviated as follows:
  - **MHz** = Megahertz
  - **μs** = Microseconds
  - **kBaud, kbit** = 1000 characters/bits per second
  - **MBaud, Mbit** = 1,000,000 characters/bits per second
  - **Kbyte, KB** = 1024 bytes of memory
  - **Mbyte, MB** = 1048576 bytes of memory

In general, the k prefix scales a unit by 1000 whereas the K prefix scales a unit by 1024. Hence, the Kbyte unit scales the expression preceding it by 1024. The kBaud unit scales the expression preceding it by 1000. The M prefix scales by 1,000,000 or 1048576. For example, 1 Kbyte is 1024 bytes, 1 Mbyte is 1024 × 1024 bytes, 1 kBaud/kbit are 1000 characters/bits per second, 1 MBaud/Mbit are 1000000 characters/bits per second, and 1 MHz is 1,000,000 Hz.



- Data format quantities are defined as follows:
  - **Byte** = 8-bit quantity
  - **Half-word** = 16-bit quantity
  - **Word** = 32-bit quantity
  - **Double-word** = 64-bit quantity

### Bit Function Terminology

In tables where register bits or bit fields are defined, the following conventions are used to indicate the access types.

**Table 1 Bit Function Terminology**

Bit Function	Description
<b>rw</b>	The bit or bit field can be read and written.
<b>rwh</b>	As rw, but bit or bit field can be also set or reset by hardware. If not otherwise documented the software takes priority in case of a write conflict between software and hardware.
<b>r</b>	The bit or bit field can only be read (read-only).
<b>w</b>	The bit or bit field can only be written (write-only). A read to this register will always give a default value back.
<b>rh</b>	This bit or bit field can be modified by hardware (read-hardware, typical example: status flags). A read of this bit or bit field give the actual status of this bit or bit field back. Writing to this bit or bit field has no effect to the setting of this bit or bit field.

### Register Access Modes

Read and write access to registers and memory locations are sometimes restricted. In memory and register access tables, the following terms are used.

**Table 2 Register Access Modes**

Symbol	Description
PV (SV), U	Access permitted in Privileged (Supervisor) Mode. <b>Note: ARM® Cortex M0 processor does not support different privilege levels. Only Privileged (Supervisor) Mode is supported in XMC1000 Family. Symbol “U” and Symbol “PV” can be used to represent the access permitted in this mode.</b>
BP	Indicates that this register can only be access when the bit protection is disabled. See detailed description of Bit Protection Scheme in the Memory Organisation chapter.

**Table 2 Register Access Modes (cont'd)**

<b>Symbol</b>	<b>Description</b>
32	Only 32-bit word accesses are permitted to this register/address range.
NC	No change, indicated register is not changed.
BE	Indicates that an access to this address range generates a Bus Error.
nBE	Indicates that no Bus Error is generated when accessing this address range.

### Reserved Bits

Register bit fields named **Reserved** or **0** indicate unimplemented functions with the following behavior.

- Reading these bit fields returns 0.
- These bit fields should be written with 0 if the bit field is defined as r or rh.
- These bit fields have to be written with 0 if the bit field is defined as rw.

These bit fields are reserved. The detailed description of these bit fields can be found in the register descriptions.

### Abbreviations and Acronyms

The following acronyms and terms are used in this document:

ACMP	Analog Comparator
AHB	Advanced High-performance Bus
AMBA	Advanced Microcontroller Bus Architecture
ANACTRL	Analog Control Unit
APB	Advanced Peripheral Bus
ASC	Asynchronous Serial Channel
BCCU	Brightness and Colour Control Unit
BMI	Boot Mode Index
CMSIS	Cortex Microcontroller Software Interface Standard
CPU	Central Processing Unit
CCU4	Capture Compare Unit 4
CCU8	Capture Compare Unit 8
CRC	Cyclic Redundancy Code
DCO	Digitally Controlled Oscillator
ECC	Error Correction Code

ERU	Event Request Unit
EVR	Embedded Voltage Regulator
FPU	Floating Point Unit
GPIO	General Purpose Input/Output
HMI	Human-Machine Interface
IIC	Inter Integrated Circuit (also known as I2C)
IIS	Inter-IC Sound Interface
I/O	Input / Output
JTAG	Joint Test Action Group = IEEE1149.1
LED	Light Emitting Diode
LEDTS	LED and Touch Sense Control Unit
MSB	Most Significant Bit
NC	Not Connected
NMI	Non-Maskable Interrupt
NVIC	Nested Vectored Interrupt Controller
ORC	Out of Range Comparator
PAU	Peripheral Access Unit
POSIF	Position Interface
PRNG	Pseudo Random Number Generator
ROM	Read-Only Memory
RAM	Random Access Memory
RTC	Real Time Clock
SCU	System Control Unit
SFR	Special Function Register
SHS	Sample and Hold Sequencer
SPI	Serial Peripheral Interface
SRAM	Static RAM
SR	Service Request
SSC	Synchronous Serial Channel
SSW	Start-up Software
TSE	Temperature Sensor
UART	Universal Asynchronous Receiver Transmitter

---

**About this Document**

USIC	Universal Serial Interface Channel
VADC	Versatile Analog-to-Digital Converter
WDT	Watchdog Timer

# Introduction

# 1 Introduction

The XMC1200 series belongs to the XMC1000 Family of industrial microcontrollers based on the ARM Cortex-M0 processor core. The XMC1200 series devices are optimized for LED Lighting applications and Human-Machine interface (HMI).

Increasing complexity and demand for computing power of embedded control applications requires microcontrollers to have a significant CPU performance, integrated peripheral functionality and rapid development environment enabling short time-to-market, without compromising cost efficiency. Nonetheless the architecture of the XMC1200 microcontroller pursue successful hardware and software concepts, which have been established in Infineon microcontroller families.

## 1.1 Overview

The XMC1200 series devices combine the extended functionality and performance of the Cortex-M0 core with powerful on-chip peripheral subsystems and on-chip memory units. The following key features are available within the range of XMC1200 series devices:

### CPU Subsystem

- CPU Core
  - High Performance 32-bit Cortex-M0 CPU
  - Most of 16-bit Thumb instruction set
  - Subset of 32-bit Thumb2 instruction set
  - High code density with 32-bit performance
  - Single cycle 32-bit hardware multiplier
  - System timer (SysTick) for Operating System support
  - Ultra low power consumption
- Nested Vectored Interrupt Controller (NVIC)
- Event Request Unit (ERU) for programmable processing of external and internal service requests

### On-Chip Memories

- 8 kbytes on-chip ROM
- 16 kbytes on-chip high-speed SRAM
- up to 200 kbytes on-chip Flash program and data memory

### Communication Peripherals

- Two Universal Serial Interface Channels (USIC), usable as UART, double-SPI, quad-SPI, IIC, IIS and LIN interfaces
- LED and Touch-Sense Controller (LEDTS) for Human-Machine interface

### **Analog Frontend Peripherals**

- A/D Converters, up to 12 channels, includes 2 sample and hold stages and a fast 12-bit analog to digital converter with adjustable gain
- Up to 8 channels of out of range comparators (ORC)
- Up to 3 fast analog comparators (ACMP)

### **Industrial Control Peripherals**

- Capture/Compare Units 4 (CCU4) for use as general purpose timers
- Brightness and Colour Control Unit (BCCU), for LED color and dimming application

### **System Control**

- Window Watchdog Timer (WDT) for safety sensitive applications
- Temperature Sensor (TSE)
- Real Time Clock module with alarm support (RTC)
- System Control Unit (SCU) for system configuration and control
- Pseudo random number generator (PRNG), provides random data with fast generation times

### **Input/Output Lines With Individual Bit Controllability**

- Tri-stated in input mode
- Push/pull or open drain output mode
- Configurable pad hysteresis

### **Debug System**

- Access through the standard ARM serial wire debug (SWD) or the single pin debug (SPD) interface
- A breakpoint unit (BPU) supporting up to 4 hardware breakpoints
- A watchpoint unit (DWT) supporting up to 2 watchpoints

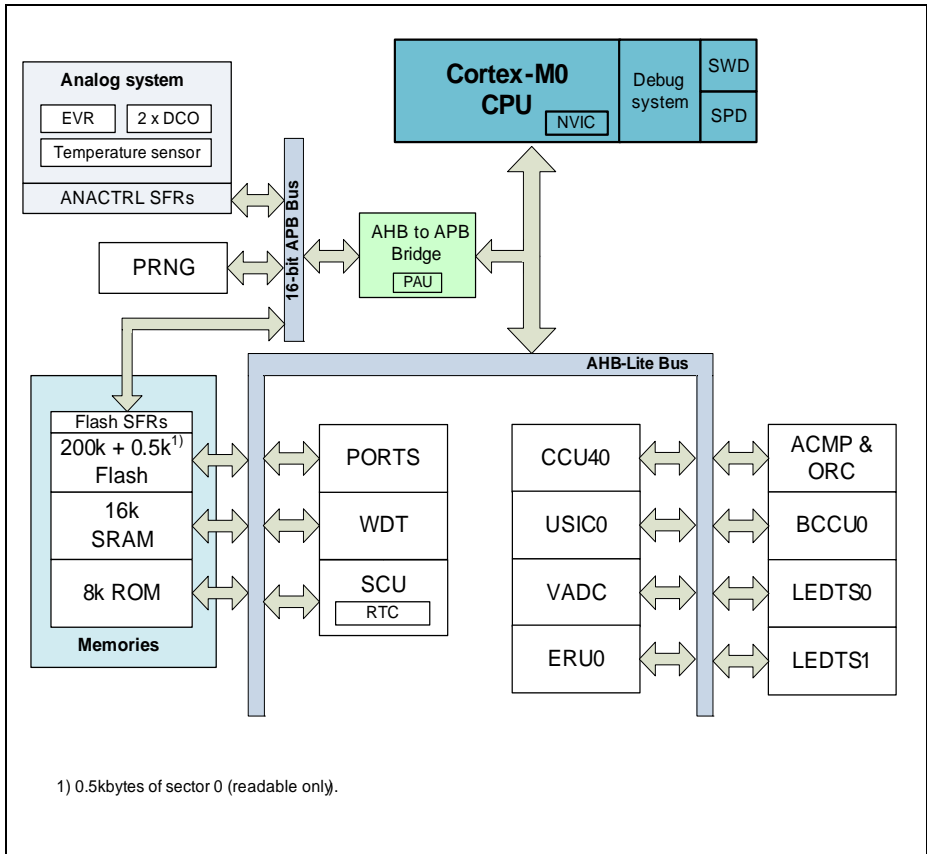
### **Packages Information**

- PG-TSSOP-38
- PG-TSSOP-28
- PG-TSSOP-16

*Note: For details about package availability for a particular derivative please check the datasheet.*

### 1.1.1 Block Diagram

The diagram below shows the functional blocks and their basic connectivity within the XMC1200 System.



**Figure 1-1 XMC1200 Functional diagram**

### 1.2 Core Processing Units

The XMC1200 system core consists of the CPU and the memory interface blocks for memories.



### **1.2.1 Central Processing Unit (CPU)**

The ARM Cortex-M0 processor is built on a highly area and power optimized 32-bit processor core, with a 3-stage pipeline von Neumann architecture. The processor delivers exceptional energy efficiency through a small but powerful instruction set and extensively optimized design, providing high-end processing hardware including a single cycle multiplier.

The instruction set is based on the 16-bit Thumb instruction set and includes Thumb-2 technology. This provides the exceptional performance expected of a modern 32-bit architecture, with a higher code density than other 8-bit and 16-bit microcontrollers.

### **1.2.2 Programmable Multiple Priority Interrupt System (NVIC)**

The XMC1200 provides separate interrupt nodes that may be assigned to 4 interrupt priority levels. Most interrupt sources are connected to a dedicated interrupt node. In some cases, multi-source interrupt nodes are incorporated for efficient use of system resources. These nodes can be activated by several source requests and are controlled via interrupt subnode control registers.

## **1.3 System Units**

The XMC1200 controllers provide a number of system resources designed around the CPU.

### **1.3.1 Memories**

**8 kbytes of ROM (ROM) memory** for boot code execution and exception vector table. The ROM contains system basic initialization sequence code and is executed immediately after reset release. The Bootstrap Loaders(BSL) and User Routines are also stored in the ROM.

**Up to 200 kbytes of on-chip Flash memory** store code or constant data. Dynamic error correction provides high read data security for all read accesses.

**16 kbytes of on-chip code RAM (SRAM)** are provided to store user code or data, as well as system variables such as system stack. The SRAM is accessed via the AHB and provides zero-waitstate access for CPU code execution.

### **1.3.2 Watchdog Timer (WDT)**

The main purpose of the Window Watchdog Timer is to improve the system integrity. WDT triggers the system reset or other corrective action like e.g. an interrupt if the main program, due to some fault condition, neglects to regularly service the watchdog. The intention is to bring the system back from the unresponsive state into normal operation.

### **1.3.3 Real Timer Clock (RTC)**

Real-time clock (RTC) is a clock that keeps track of the current time. RTCs are present in almost any electronic device which needs to keep accurate time in a digital format for clock displays and computer systems..

### **1.3.4 System Control unit (SCU)**

The System Control Unit (SCU) handles all system control tasks besides the debug related tasks. All functions are tightly coupled and thus, they are conveniently handled by one unit, SCU. It consists of the Power Control Unit (PCU), Reset Control Unit, Clock Control Unit (CCU) and the Miscellaneous Control Unit (GCU).

The CCU generates the Main clock (MCLK) and the fast Peripheral clock (PCLK) using the 64MHz DCO1 oscillator. The PCU has a Embedded Voltage Regulator (EVR) that is used to generate the core voltage. It also provides voltage monitoring detectors to secure system performance under critical condition (eg. brownout).

### **1.3.5 Pseudo Random Bit Generator (PRNG)**

The pseudo random bit generator (PRNG) provides random data with fast generation times.

## **1.4 Peripherals Units**

XMC1200 offers a set of on-chip peripherals to support industrial applications.

### **Universal Serial Interface Channel (USIC)**

The USIC is a flexible interface module covering several serial communication protocols such as ASC, LIN, SSC, I2C, I2S. A USIC module contains two independent communication channels which can be used in parallel. A FIFO allows transmit and result buffering for relaxing real-time conditions. Multiple chip select signals are available for communication with multiple devices on the same channel.

### **LED and Touch Sense (LEDTS)**

The LEDTS module drives LEDs and controls touch pads used in human-machine interface (HMI) applications. There are 2 kernels of the LEDTS module in this device. These 2 kernels of LEDTS can measure the capacitance of up to 16 touch pads using the relaxation oscillator (RO) topology. It can also drive up to 88 LEDs in LED matrix. Touch pads and LEDs can share pins to minimize the number of pins needed for such applications.

### **Analog to Digital Converter (VADC)**

The Versatile Analog-to-Digital Converter module consists of an independent kernels which operate according to the successive approximation principle (SAR). The resolution is programmable from 8 to 12bit.

The kernel provides a versatile state machine allowing complex measurement sequences. The kernels can be synchronized and conversions may run completely in background. Multiple trigger events can be prioritized and allow the exact measurement of time critical signals. The result buffering and handling avoids data loss and ensures consistency. Self-test mechanisms can be used for plausibility checks.

The basic structure supports a clean software architecture where tasks may only read valid results and do not need to care for starting conversions.

### **Analog Comparator (ACMP) and Out of Range Comparator (ORC)**

The Analog Comparator is used to compare the voltage of two analog inputs and a digital output indicating which input voltage is higher. One of the input can either be the internal reference voltage or from external pin. A low power mode is available to help to reduce the total power consumption.

A number of out-of-range on-chip comparators serve the purpose of over-voltage monitoring for analog input pins of the VADC.

### **Temperature Sensor (TSE)**

The Temperature Sensor generates a measurement result that indicates directly the die temperature. It is also capable of generating interrupt requests when the temperature measurement crosses the selectable upper/lower threshold value.

### **Capture/Compare Unit 4 (CCU4)**

The CCU4 peripheral is a major component for systems that need general purpose timers for signal monitoring/conditioning and Pulse Width Modulation (PWM) signal generation. Power electronic control systems like switched mode power supplies or uninterruptible power supplies can easily be implemented with the functions inside the CCU4 peripheral.

The internal modularity of CCU4 translates into a software friendly system for fast code development and portability between applications.

### **Brightness and Color Control Unit (BCCU)**

The BCCU is a dimming control peripheral for LED lighting applications that is capable of controlling multiple LED channels. A one-bit sigma-delta bit stream is provided for every channel that determines the brightness. The brightness can be changed gradually along an exponential curve to appear natural to the human eye by using dedicated

dimming engines. The module supports color control by adjusting the relative intensity of selected channels using a linear walk scheme for smooth color changes, and it also supports high-power multi-channel LED lamps by optionally “packing” the bitstream to provide a defined ON-time at the output.

### **General Purpose I/O Ports (PORTS)**

The Ports provide a generic and very flexible software and hardware interface for all standard digital I/Os. Each Port slice has individual interfaces for the operation as General Purpose I/O and it further provides the connectivity to the on-chip periphery and the control for the pad characteristics.

## **1.5 Debug Unit**

The on-chip debug system based on the ARM Cortex-M0™ debug system provides a broad range of debug and emulation features built into the XMC1200. The user software running on the XMC1200 can thus be debugged within the target system environment.

The Debug unit is controlled by an external debugging tool via the debug interface. The debugger controls the Debug unit via a set of dedicated registers accessible via the debug interface. Additionally, the Debug unit can be controlled by the CPU, e.g. by a monitor program.

Multiple breakpoints can be triggered by on-chip hardware or by software. Single stepping is supported as well as the injection of arbitrary instructions and read/write access to the complete internal address space. A breakpoint trigger can be answered with a CPU-halt, a monitor call or a data transfer.

The data transferred at a watchpoint (see above) can be obtained via the debug interface for increased performance.

# **CPU Subsystem**

## **2 Central Processing Unit (CPU)**

XMC1200 features the ARM Cortex-M0 processor. An entry-level 32-bit ARM Cortex processor designed for a broad range of embedded applications. This CPU offers significant benefits to users, including:

- a simple architecture that is easy to learn and program
- ultra-low power, energy efficient operation
- excellent code density
- deterministic, high-performance interrupt handling
- upward compatibility with Cortex-M processor family

### **References to ARM Documentation**

The following documents can be accessed through <http://infocenter.arm.com>

- [1] Cortex™-M0 Devices, Generic User Guide (ARM DUI 0467B)
- [2] ARMv6-M Architecture Reference Manual (ARM DDI 0419)
- [3] Cortex Microcontroller Software Interface Standard (CMSIS)

### **References to ARM Figures**

- [4] <http://www.arm.com>

## **2.1 Overview**

The Cortex-M0 processor is built on a highly area and power optimized 32-bit processor core, with a 3-stage pipeline von Neumann architecture. The processor delivers exceptional energy efficiency through a small but powerful instruction set and extensively optimized design, providing high-end processing hardware including a single-cycle multiplier.

The Cortex-M0 processor implements the ARMv6-M architecture, which is based on the 16-bit Thumb® instruction set and includes Thumb-2 technology. The Cortex-M0 instruction set provides exceptional performance expected of a modern 32-bit architecture, with a higher code density than other 8-bit and 16-bit microcontrollers.

The Cortex-M0 processor closely integrates a configurable NVIC, to deliver industry leading interrupt performance. The NVIC provides 4 interrupt priority levels. The tight integration of the processor core and NVIC provides fast execution of interrupt service routines (ISRs), dramatically reducing the interrupt latency. This is achieved through the hardware stacking of registers, and the ability to abandon and restart load-multiple and store-multiple operations. Interrupt handlers do not require any assembler wrapper code, removing any code overhead from the ISRs. Tail-chaining optimization also significantly reduces the overhead when switching from one ISR to another.

---

## **Central Processing Unit (CPU)**

To optimize low-power designs, the NVIC integrates with the sleep modes, that include a deep sleep function that enables the entire device to be rapidly powered down.

### **2.1.1 Features**

The CPU provides the following functionality:

- Thumb instruction set combines high code density with 32-bit performance
- integrated sleep modes for low power consumption
- fast code execution permits slower processor clock or increases sleep mode time
- single cycle 32-bit hardware multiplier
- high-performance interrupt handling for time-critical applications
- extensive debug capabilities:
  - Serial Wire Debug and Single Pin Debug reduce the number of pins required for debugging.

### **2.1.2 Block Diagram**

The Cortex-M0 core components comprise of:

#### **Processor Core**

The CPU provides most 16-bit Thumb instruction set and subset of 32-bit Thumb2 instruction set.

#### **Nested Vectored Interrupt Controller**

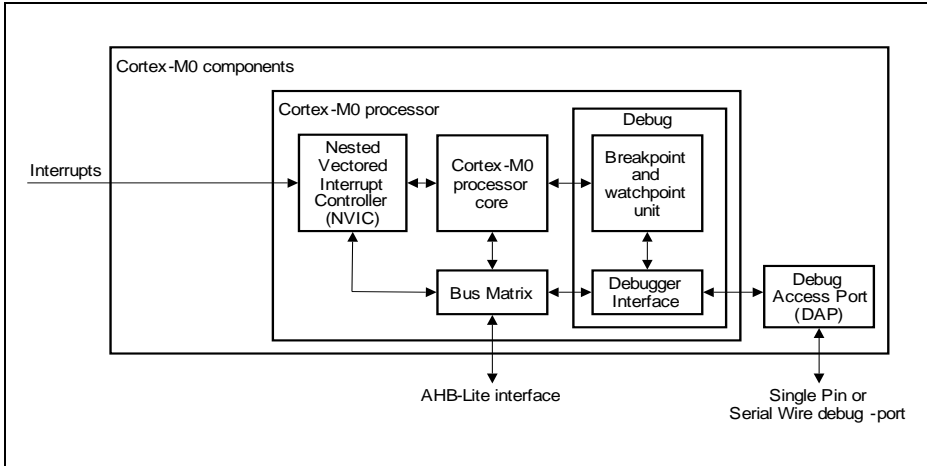
The NVIC is an embedded interrupt controller that supports low latency interrupt processing.

#### **Debug Solution**

The XMC1200 implements a complete hardware debug solution.

- Single Pin Debug (SPD) or 2-pin Serial Wire Debug (SWD)
- Extensive hardware breakpoint and watchpoint options

This provides high system control and visibility of the processor and memory even in small package devices.



**Figure 2-1 Cortex-M0 Block Diagram**

## System Level Interface

The Cortex-M0 processor provides a single system-level interface using AMBA® technology to provide high speed, low latency memory accesses.

## 2.2 Programmers Model

This section describes the Cortex-M0 programmers model. In addition to the individual core register descriptions, it contains information about the processor modes and stacks.

### 2.2.1 Processor Mode

The processor modes are:

- **Thread mode**  
Used to execute application software. The processor enters Thread mode when it comes out of reset.
- **Handler mode**  
Used to handle exception processing. The processor returns to Thread mode when it has finished all exception processing.

### 2.2.2 Stacks

The processor uses a full descending stack. This means the stack pointer holds the address of the last stacked item in memory. When the processor pushes a new item onto the stack, it decrements the stack pointer and then writes the item to the new memory



**Central Processing Unit (CPU)**

location. The processor implements two stacks, the main stack and the process stack, with a pointer for each held in independent registers, see [Stack Pointer](#).

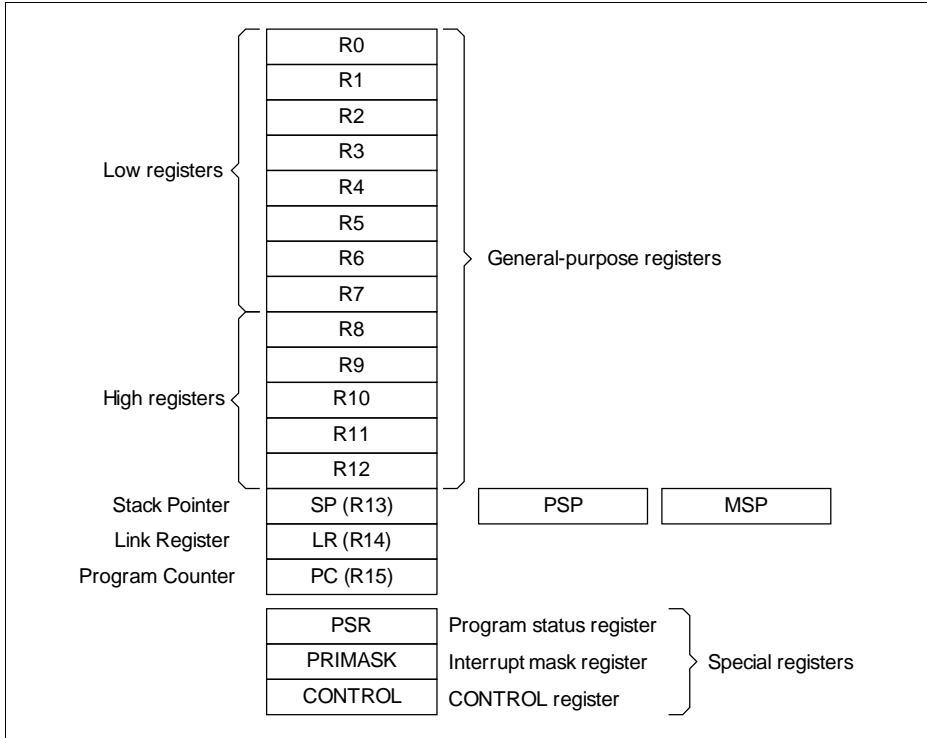
In Thread mode, the CONTROL register controls whether the processor uses the main stack or the process stack, see [CONTROL Register](#). In Handler mode, the processor always uses the main stack. The options for processor operations are:

**Table 2-1 Summary of processor mode, execution, and stack use options**

<b>Processor mode</b>	<b>Used to execute</b>	<b>Stack used</b>
Thread	Applications	Main stack or process stack <sup>1)</sup>
Handler	Exception handlers	Main stack

1) See [CONTROL Register](#).

### 2.2.3 Core Registers



**Figure 2-2 Core registers**

The processor core registers are:

**Table 2-2 Core register set summary**

Name	Type <sup>1)</sup>	Reset value	Description
R0-R12	rw	Unknown	General-purpose registers on <a href="#">Page 2-6</a>
MSP	rw	See description	Stack Pointer on <a href="#">Page 2-6</a>
PSP	rw	Unknown	Stack Pointer on <a href="#">Page 2-6</a>
LR	rw	Unknown	Link Register on <a href="#">Page 2-7</a>
PC	rw	See description	Program Counter on <a href="#">Page 2-8</a>
PSR	rw	Unknown	Program Status Register on <a href="#">Page 2-8</a>

**Central Processing Unit (CPU)**

**Table 2-2 Core register set summary (cont'd)**

Name	Type <sup>1)</sup>	Reset value	Description
APSR	rw	Unknown	Application Program Status Register on <a href="#">Page 2-9</a>
IPSR	r	00000000 <sub>H</sub>	Interrupt Program Status Register on <a href="#">Page 2-10</a>
EPSR	r	Unknown	Execution Program Status Register on <a href="#">Page 2-12</a>
PRIMASK	rw	00000000 <sub>H</sub>	Priority Mask Register on <a href="#">Page 2-13</a>
CONTROL	rw	00000000 <sub>H</sub>	CONTROL Register on <a href="#">Page 2-14</a>

1) Describes access type during program execution in thread mode and handler mode. Debug access can differ.

**General-purpose registers**

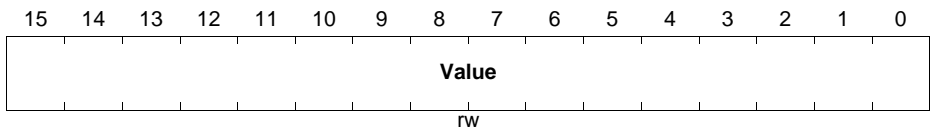
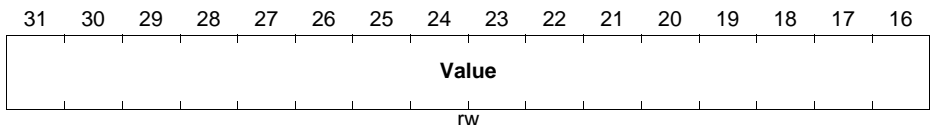
R0-R12 are 32-bit general-purpose registers for data operations.

*Note: For information on how to program the core registers, please refer to the ARMv6-M Architecture Reference Manual [2].*

**R<sub>x</sub> (x=0-12)**

**General-purpose register R<sub>x</sub>**

**Reset Value: XXXXXXXX<sub>H</sub>**



Field	Bits	Type	Description
Value	[31:0]	rw	Content of Register

**Stack Pointer**

The Stack Pointer (SP) is register R13. In Thread mode, bit[1] of the CONTROL register indicates the stack pointer to use:

- 0 = Main Stack Pointer (MSP). This is the reset value.

**Central Processing Unit (CPU)**

- 1 = Process Stack Pointer (PSP).

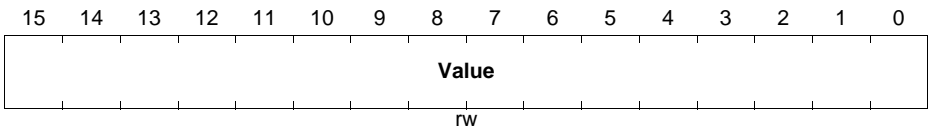
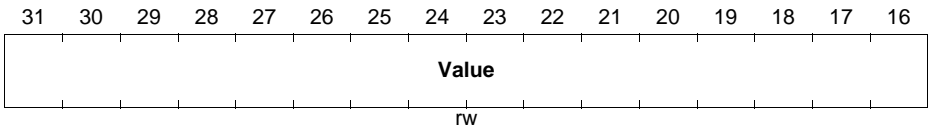
On reset, the processor loads the MSP with the value from address 00000000<sub>H</sub>.

*Note: For information on how to program the core registers, please refer to the ARMv6-M Architecture Reference Manual [2].*

**SP**

**Stack Pointer**

**Reset Value: 00000000<sub>H</sub>**



Field	Bits	Type	Description
Value	[31:0]	rw	Content of Register

**Link Register**

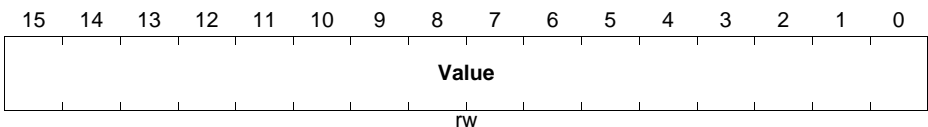
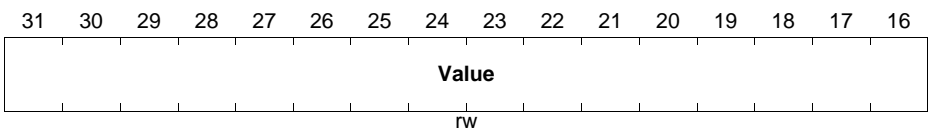
The Link Register (LR) is register R14. It stores the return information for subroutines, function calls, and exceptions. On reset, the LR value is unknown.

*Note: For information on how to program the core registers, please refer to the ARMv6-M Architecture Reference Manual [2].*

**LR**

**Link Register**

**Reset Value: XXXXXXXX<sub>H</sub>**



Field	Bits	Type	Description
Value	[31:0]	rw	Content of Register

### Program Counter

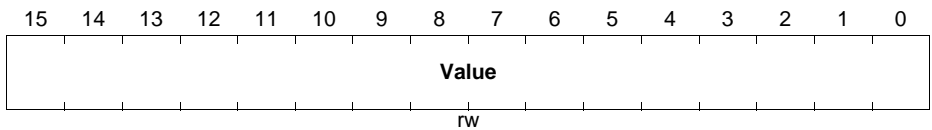
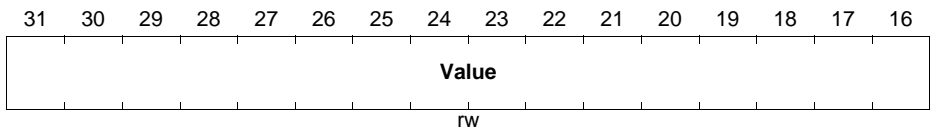
The Program Counter (PC) is register R15. It contains the current program address. On reset, the processor loads the PC with the value of the reset vector, which is at address 00000004<sub>H</sub>. Bit [0] of the value is loaded into the EPSR T-bit at reset and must be 1.

*Note: For information on how to program the core registers, please refer to the ARMv6-M Architecture Reference Manual [2].*

### PC

#### Program Counter

**Reset Value: 00000004<sub>H</sub>**



Field	Bits	Type	Description
Value	[31:0]	rw	Content of Register

### Program Status Register

The Program Status Register (PSR) combines:

- Application Program Status Register (APSR)
- Interrupt Program Status Register (IPSR)
- Execution Program Status Register (EPSR)

These registers are mutually exclusive bit fields in the 32-bit PSR.

Access these registers individually or as a combination of any two or all three registers, using the register name as an argument to the MSR or MRS instructions. For example:

- read all of the registers using PSR with the MRS instruction
- write to the APSR N, Z, C, and V bits using APSR with the MSR instruction

The PSR combinations and attributes are:

**Table 2-3 PSR register combinations**

Register	Type	Combination
PSR	rw <sup>1)2)</sup>	APSR, EPSR, and IPSR
IEPSR	r	EPSR and IPSR
IAPSR	rw <sup>1)</sup>	APSR and IPSR
EAPSR	rw <sup>2)</sup>	APSR and EPSR

1) The processor ignores writes to the IPSR bits.

2) Reads of the EPSR bits return zero, and the processor ignores writes to the these bits

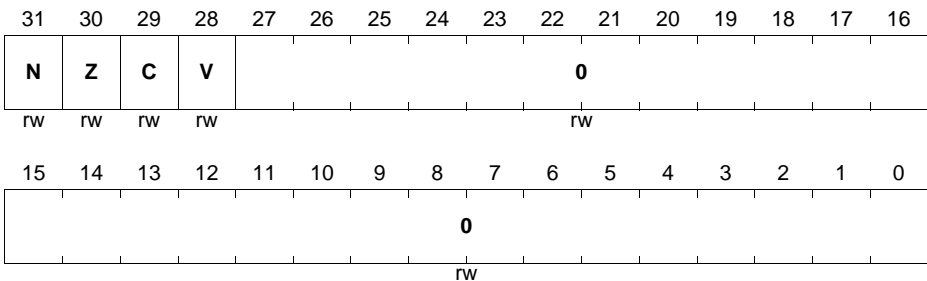
### Application Program Status Register

The APSR contains the current state of the condition flags from previous instruction executions. See the register summary in [Table 2-2](#) for its attributes.

#### APSR

#### Application Program Status Register

Reset Value: XXXXXXXX<sub>H</sub>



Field	Bits	Type	Description
<b>N</b>	31	rw	<b>Negative flag</b>
<b>Z</b>	30	rw	<b>Zero flag</b>
<b>C</b>	29	rw	<b>Carry or borrow flag</b>
<b>V</b>	28	rw	<b>Overflow flag</b>
<b>0</b>	[27:0]	r	<b>Reserved</b>

**Central Processing Unit (CPU)**

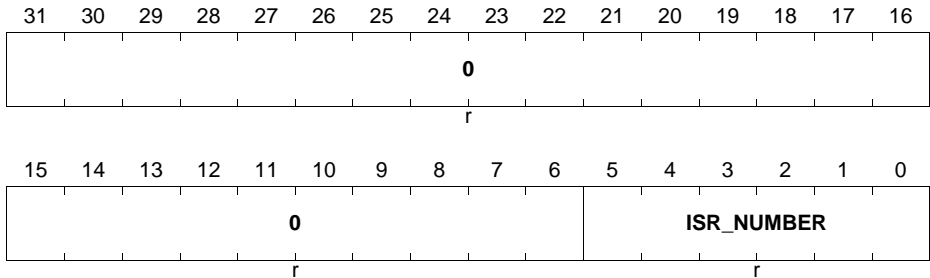
**Interrupt Program Status Register**

The IPSR contains the exception type number of the current Interrupt Service Routine (ISR). See the register summary in [Table 2-2](#) for its attributes.

**IPSR**

**Interrupt Program Status Register**

**Reset Value: 00000000<sub>H</sub>**



Field	Bits	Type	Description
0	[31:6]	r	Reserved

**Central Processing Unit (CPU)**

<b>Field</b>	<b>Bits</b>	<b>Type</b>	<b>Description</b>
<b>ISR_NUMBER</b>	[5:0]	r	<p><b>Number of the current exception</b></p> <p>0<sub>D</sub> Thread mode</p> <p>1<sub>D</sub> Reserved</p> <p>2<sub>D</sub> Reserved</p> <p>3<sub>D</sub> HardFault</p> <p>4<sub>D</sub> Reserved</p> <p>5<sub>D</sub> Reserved</p> <p>6<sub>D</sub> Reserved</p> <p>7<sub>D</sub> Reserved</p> <p>8<sub>D</sub> Reserved</p> <p>9<sub>D</sub> Reserved</p> <p>10<sub>D</sub> Reserved</p> <p>11<sub>D</sub> SVCall</p> <p>12<sub>D</sub> Reserved</p> <p>13<sub>D</sub> Reserved</p> <p>14<sub>D</sub> PendSV</p> <p>15<sub>D</sub> SysTick</p> <p>16<sub>D</sub> IRQ0</p> <p>...</p> <p>47<sub>D</sub> IRQ31</p> <p>48<sub>D</sub>-63<sub>D</sub> Reserved</p> <p>See Exception types in <a href="#">Section 2.5.2</a> for more information.</p>



## Execution Program Status Register

The EPSR contains the Thumb state bit.

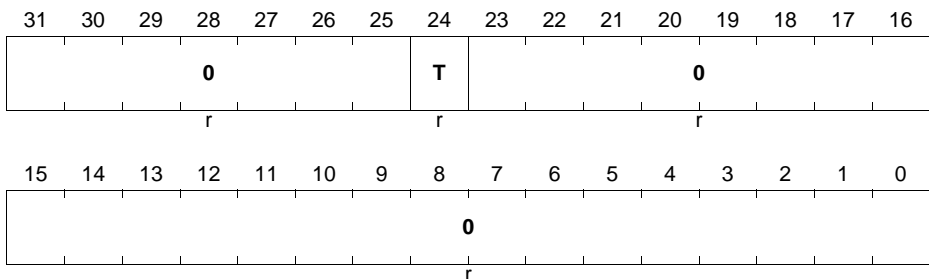
See the register summary in [Table 2-2](#) for the EPSR attributes.

Attempts to read the EPSR directly through application software using the MSR instruction always return zero. Attempts to write the EPSR using the MSR instruction in application software are ignored. Fault handlers can examine the EPSR value in the stacked PSR to determine the cause of the fault. See Exception Entry and Return in [Section 2.5.6](#).

### EPSR

#### Execution Program Status Register

Reset Value: XXXXXXXX<sub>H</sub>



Field	Bits	Type	Description
0	[31:25]	r	Reserved
T	24	r	Thumb state bit See Thumb state.
0	[23:0]	r	Reserved

### Interruptible-restartable instructions

When an interrupt occurs during the execution of an LDM, STM, PUSH, POP instruction, the processor abandons execution of the instruction.

After servicing the interrupt, the processor restarts execution of the instruction from the beginning.

### Thumb state

The Cortex-M0 processor only supports execution of instructions in Thumb state. The following can clear the T bit to 0:

- instructions BLX, BX and POP{PC}

**Central Processing Unit (CPU)**

- restoration from the stacked xPSR value on an exception return
- bit[0] of the vector value on an exception entry.

Attempting to execute instructions when the T bit is 0 results in a HardFault or lockup. See Lockup in [Section 2.6.1](#) for more information.

**Exception mask registers**

The exception mask registers disable the handling of exceptions by the processor. Disable exceptions where they might impact on timing critical tasks or code sequences requiring atomicity.

Exceptions can be disabled or re-enabled by the MSR and MRS instructions, or the CPS instruction, to change the value of PRIMASK or FAULTMASK.

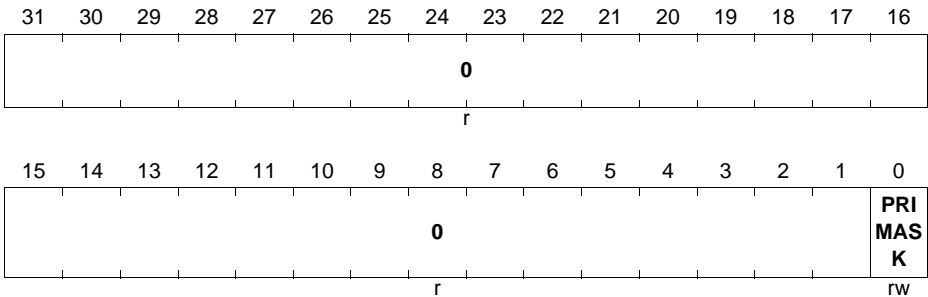
**Priority Mask Register**

The PRIMASK register prevents activation of all exceptions with configurable priority. See the register summary in [Table 2-2](#) for its attributes.

**PRIMASK**

**Priority Mask Register**

**Reset Value: 00000000<sub>H</sub>**



Field	Bits	Type	Description
<b>0</b>	[31:1]	r	<b>Reserved</b>
<b>PRIMASK</b>	0	rw	<b>Priority Mask</b> 0 <sub>B</sub> No effect. 1 <sub>B</sub> Prevents the activation of all exceptions with configurable priority.

**Central Processing Unit (CPU)**

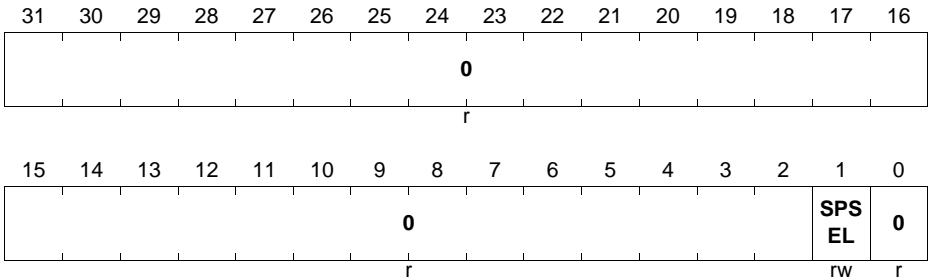
**CONTROL Register**

The CONTROL register controls the stack used when the processor is in Thread mode. See the register summary in [Table 2-2](#) for its attributes.

**CONTROL**

**CONTROL Register**

**Reset Value: 00000000<sub>H</sub>**



Field	Bits	Type	Description
<b>0</b>	[31:2]	r	<b>Reserved</b>
<b>SPSEL</b>	1	rw	<b>Active stack pointer</b> This bit defines the current stack. In Handler mode, this bit reads as zero and ignores writes. 0 <sub>B</sub> MSP is the current stack pointer 1 <sub>B</sub> PSP is the current stack pointer
<b>0</b>	0	r	<b>Reserved</b>

Handler mode always uses the MSP, so the processor ignores explicit writes to the active stack pointer bit of the CONTROL register when in Handler mode. The exception entry and return mechanisms automatically update the CONTROL register.

In an OS environment, it is recommended that threads running in Thread mode use the process stack and the kernel and exception handlers use the main stack.

By default, Thread mode uses the MSP. To switch the stack pointer used in Thread mode to the PSP, use the MSR instruction to set the Active stack pointer bit to 1.

*Note: When changing the stack pointer, software must use an ISB instruction immediately after the MSR instruction. This ensures that instructions after the ISB instruction execute using the new stack pointer.*

## 2.2.4 Exceptions and Interrupts

The Cortex-M0 processor supports interrupts and system exceptions. The processor and the NVIC prioritize and handle all exceptions. An interrupt or exception changes the normal flow of software control. The processor uses handler mode to handle all exceptions except for reset. See Exception entry on [Section 2.5.6.1](#) and Exception return on [Section 2.5.6.2](#) for more information.

The NVIC registers control interrupt handling. See Interrupt System chapter for more information.

## 2.2.5 Data Types

The processor:

- supports the following data types:
  - 32-bit words
  - 16-bit halfwords
  - 8-bit bytes
- manages all data memory accesses as little-endian. See Memory regions, types and attributes in [Section 2.3.1](#) for more information.

## 2.2.6 The Cortex Microcontroller Software Interface Standard

For a Cortex-M0 microcontroller system, the Cortex Microcontroller Software Interface Standard (CMSIS) [\[3\]](#) defines:

- a common way to:
  - access peripheral registers
  - define exception vectors
- the names of:
  - the registers of the core peripherals
  - the core exception vectors
- a device-independent interface for RTOS kernels.

The CMSIS includes address definitions and data structures for the core peripherals in the Cortex-M0 processor.

CMSIS simplifies software development by enabling the reuse of template code and the combination of CMSIS-compliant software components from various middleware vendors. Software vendors can expand the CMSIS to include their peripheral definitions and access functions for those peripherals.

This document includes the register names defined by the CMSIS, and gives short descriptions of the CMSIS functions that address the processor core and the core peripherals.

**Central Processing Unit (CPU)**

*Note: This document uses the register short names defined by the CMSIS. In a few cases these differ from the architectural short names that might be used in other documents.*

The following sections give more information about the CMSIS:

- Power Management Programming Hints in [Section 2.7.3](#)
- CMSIS Functions in [Section 2.2.7](#)
- Accessing CPU Registers using CMSIS in Interrupt System chapter
- NVIC programming hints in Interrupt System chapter

For additional information please refer to <http://www.onarm.com/cmsis>

**2.2.7 CMSIS Functions**

ISO/IEC C code cannot directly access some Cortex-M0 instructions. This section describes intrinsic functions that can generate these instructions, provided by the CMSIS and that might be provided by a C compiler. If a C compiler does not support an appropriate intrinsic function, an inline assembler may be used to access the relevant instruction.

The CMSIS provides the following intrinsic functions to generate instructions that ISO/IEC C code cannot directly access:

**Table 2-4 CMSIS functions to generate some Cortex-M0 instructions**

<b>Instruction</b>	<b>CMSIS intrinsic function</b>
CPSIE i	void __enable_irq (void)
CPSID i	void __disable_irq (void)
ISB	void __ISB (void)
DSB	void __DSB (void)
DMB	void __DMB (void)
NOP	void __NOP (void)
REV	uint32_t __REV (uint32_t int value)
REV16	uint32_t __REV16 (uint32_t int value)
REVSH	uint32_t __REVSH (uint32_t int value)
WFE	void __WFE (void)
WFI	void __WFI (void)

The CMSIS also provides a number of functions for accessing the special registers using MRS and MSR instructions:

**Table 2-5 CMSIS functions to access the special registers**

<b>Special register</b>	<b>Access</b>	<b>CMSIS function</b>
PRIMASK	Read	uint32_t __get_PRIMASK (void)
	Write	void __set_PRIMASK (uint32_t value)
CONTROL	Read	uint32_t __get_CONTROL (void)
	Write	void __set_CONTROL (uint32_t value)
MSP	Read	uint32_t __get_MSP (void)
	Write	void __set_MSP (uint32_t TopOfMainStack)
PSP	Read	uint32_t __get_PSP (void)
	Write	void __set_PSP (uint32_t TopOfMainStack)

**Central Processing Unit (CPU)**

**2.3 Memory Model**

This section describes the processor memory map and the behavior of memory accesses. The processor has a fixed default memory map that provides up to 4GB of addressable memory. The memory map is:

Device	511MB	0xFFFFFFFF
Private peripheral bus	1.0MB	0xE0100000 0xE00FFFFF
External device	1.0GB	0xE0000000 0xDFFFFFFF
External RAM	1.0GB	0xA0000000 0x9FFFFFFF
Peripheral	0.5GB	0x60000000 0x5FFFFFFF
SRAM	0.5GB	0x40000000 0x3FFFFFFF
Code	0.5GB	0x20000000 0x1FFFFFFF
		0x00000000

**Figure 2-3 Memory map**

## Central Processing Unit (CPU)

The processor reserves regions of the Private peripheral bus (PPB) address range for core peripheral registers, see About the Private Peripherals in [Section 2.8.1](#).

### 2.3.1 Memory Regions, Types and Attributes

The memory map is split into regions. Each region has a defined memory type, and some regions have additional memory attributes. The memory type and attributes determine the behavior of accesses to the region.

The memory types are:

<b>Normal</b>	The processor can re-order transactions for efficiency, or perform speculative reads.
<b>Device</b>	The processor preserves transaction order relative to other transactions to Device or Strongly-ordered memory.
<b>Strongly-ordered</b>	The processor preserves transaction order relative to all other transactions.

The different ordering requirements for Device and Strongly-ordered memory mean that the memory system can buffer a write to Device memory, but must not buffer a write to Strongly-ordered memory.

The additional memory attributes include:

<b>Execute Never (XN)</b>	Means the processor prevents instruction accesses. A HardFault exception is generated on execution of an instruction fetched from an XN region of memory.
---------------------------	---

### 2.3.2 Memory System Ordering of Memory Accesses

For most memory accesses caused by explicit memory access instructions, the memory system does not guarantee that the order in which the accesses complete matches the program order of the instructions, providing any re-ordering does not affect the behavior of the instruction sequence. Normally, if correct program execution depends on two memory accesses completing in program order, software must insert a memory barrier instruction between the memory access instructions, see Software ordering of memory accesses in [Section 2.3.4](#).

However, the memory system does guarantee some ordering of accesses to Device and Strongly-ordered memory. For two memory access instructions A1 and A2, if A1 occurs before A2 in program order, the ordering of the memory accesses caused by two instructions is described in [Figure 2-4](#).



**Central Processing Unit (CPU)**

A1 \ A2	Normal access	Device access	Strongly-ordered access
Normal access	-	-	-
Device access	-	<	<
Strongly-ordered access	-	<	<

**Figure 2-4 Memory system ordering**

Where:

- “-” Means that the memory system does not guarantee the ordering of the accesses.
- “<” Means that accesses are observed in program order, that is, A1 is always observed before A2.

### 2.3.3 Behavior of Memory Accesses

The behavior of accesses to each region in the memory map is:

**Table 2-6 Memory access behavior**

Address range	Memory region	Memory type <sup>1)</sup>	XN <sup>1)</sup>	Description
0x00000000-0x1FFFFFFF	Code	Normal	-	Executable region for program code. Data can be placed here.
0x20000000-0x3FFFFFFF	SRAM	Normal	-	Executable region for data. Code can be placed here.
0x40000000-0x5FFFFFFF	Peripheral	Device	XN	Peripherals region.
0x60000000-0x9FFFFFFF	External RAM	Normal	-	Executable region for data.
0xA0000000-0xDFFFFFFF	External device	Device	XN	External device memory.

**Central Processing Unit (CPU)**

**Table 2-6 Memory access behavior (cont'd)**

<b>Address range</b>	<b>Memory region</b>	<b>Memory type<sup>1)</sup></b>	<b>XN<sup>1)</sup></b>	<b>Description</b>
0xE0000000-0xE00FFFFFF	Private Peripheral Bus	Strongly-ordered	XN	This region includes the NVIC, system timer, and system control block. Only word accesses can be used in this region.
0xE0100000-0xFFFFFFFF	Device	Device	XN	Vendor specific

1) See Memory regions, types and attributes in [Section 2.3.1](#) for more information.

The Code, SRAM, and external RAM regions can hold programs.

### 2.3.4 Software Ordering of Memory Accesses

The order of instructions in the program flow does not always guarantee the order of the corresponding memory transactions. This is because:

- the processor can reorder some memory accesses to improve efficiency, providing this does not affect the behavior of the instruction sequence.
- memory or devices in the memory map have different wait states
- some memory accesses are buffered or speculative.

Memory system ordering of memory accesses in [Section 2.3.2](#) describes the cases where the memory system guarantees the order of memory accesses. Otherwise, if the order of memory accesses is critical, software must include memory barrier instructions to force that ordering. The processor provides the following memory barrier instructions:

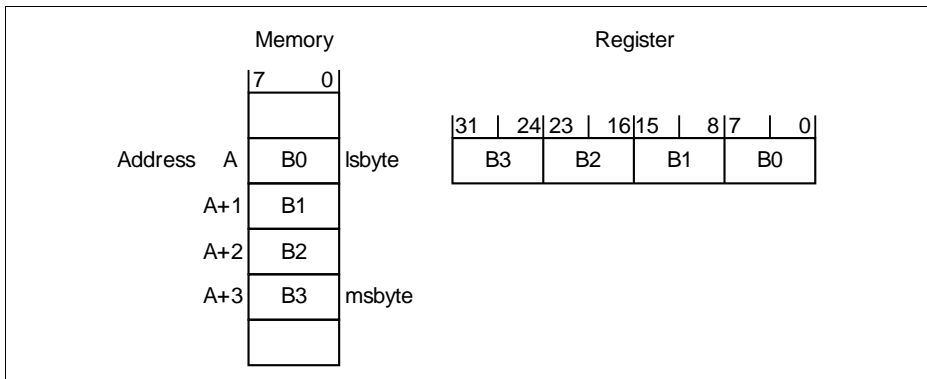
- DMB**            The Data Memory Barrier (DMB) instruction ensures that outstanding memory transactions complete before subsequent memory transactions.
- DSB**            The Data Synchronization Barrier (DSB) instruction ensures that outstanding memory transactions complete before subsequent instructions execute.
- ISB**            The Instruction Synchronization Barrier (ISB) ensures that the effect of all completed memory transactions is recognizable by subsequent instructions.

## 2.3.5 Memory Endianness

The processor views memory as a linear collection of bytes numbered in ascending order from zero. For example, bytes 0-3 hold the first stored word, and bytes 4-7 hold the second stored word. [Section 2.3.5.1](#) describes how words of data are stored in memory.

### 2.3.5.1 Little-endian format

In little-endian format, the processor stores the least significant byte (lsbyte) of a word at the lowest-numbered byte, and the most significant byte (msbyte) at the highest-numbered byte. An example of the little-endian format is described in [Figure 2-5](#).



**Figure 2-5 Little-endian format (Example)**

## 2.4 Instruction Set

**Table 2-7** lists the supported Cortex-M0 instructions. For more information on the instructions and operands, please refer to the Cortex™-M0 Devices, Generic User Guide available through [\[1\]](#).

**Table 2-7 Cortex-M0 instructions**

<b>Mnemonic</b>	<b>Operands</b>	<b>Brief description</b>	<b>Flags</b>
ADCS	{Rd,} Rn, Rm	Add with carry	N,Z,C,V
ADD{S}	{Rd,} Rn, <Rm #imm>	Add	N,Z,C,V
ADR	Rd, label	PC-relative Address to Register	-
ANDS	{Rd,} Rn, Rm	Bitwise AND	N,Z
ASRS	{Rd,} Rm, <Rs #imm>	Arithmetic Shift Right	N,Z,C
B{cc}	label	Branch {conditionally}	-
BICS	{Rd,} Rn, Rm	Bit Clear	N,Z
BKPT	#imm	Breakpoint	-
BL	label	Branch with Link	-
BLX	Rm	Branch indirect with Link	-
BX	Rm	Branch indirect	-
CMN	Rn, Rm	Compare Negative	N,Z,C,V
CMP	Rn, <Rm #imm>	Compare	N,Z,C,V
CPSID	i	Change Processor State, Disable Interrupts	-
CPSIE	i	Change Processor State, Enable Interrupts	-
DMB	-	Data Memory Barrier	-
DSB	-	Data Synchronization Barrier	-
EORS	{Rd,} Rn, Rm	Exclusive OR	N,Z
ISB	-	Instruction Synchronization Barrier	-
LDM	Rn{!}, reglist	Load Multiple registers, increment after	-

**Central Processing Unit (CPU)**
**Table 2-7 Cortex-M0 instructions (cont'd)**

<b>Mnemonic</b>	<b>Operands</b>	<b>Brief description</b>	<b>Flags</b>
LDR	Rt, label	Load Register from PC-relative address	-
LDR	Rt, [Rn, <Rm #imm>]	Load Register with word	-
LDRB	Rt, [Rn, <Rm #imm>]	Load Register with byte	-
LDRH	Rt, [Rn, <Rm #imm>]	Load Register with halfword	-
LDRSB	Rt, [Rn, <Rm #imm>]	Load Register with signed byte	-
LDRSH	Rt, [Rn, <Rm #imm>]	Load Register with signed halfword	-
LSLS	{Rd,} Rn, <Rs #imm>	Logical Shift Left	N,Z,C
LSRS	{Rd,} Rn, <Rs #imm>	Logical Shift Right	N,Z,C
MOV{S}	Rd, Rm	Move	N,Z
MRS	Rd, spec_reg	Move to general register from special register	-
MSR	spec_reg, Rm	Move to special register from general register	N,Z,C,V
MULS	Rd, Rn, Rm	Multiply, 32-bit result	N,Z
MVNS	Rd, Rm	Bitwise NOT	N,Z
NOP	-	No Operation	-
ORRS	{Rd,} Rn, Rm	Logical OR	N,Z
POP	reglist	Pop registers from stack	-
PUSH	reglist	Push registers onto stack	-
REV	Rd, Rm	Byte-Reverse word	-
REV16	Rd, Rm	Byte-Reverse packed halfwords	-
REVSH	Rd, Rm	Byte-Reverse signed halfword	-
RORS	{Rd,} Rn, Rs	Rotate Right	N,Z,C
RSBS	{Rd,} Rn, #0	Reverse Subtract	N,Z,C,V

**Table 2-7 Cortex-M0 instructions (cont'd)**

<b>Mnemonic</b>	<b>Operands</b>	<b>Brief description</b>	<b>Flags</b>
SBCS	{Rd,} Rn, Rm	Subtract with Carry	N,Z,C,V
STM	Rn!, reglist	Store Multiple registers, increment after	-
STR	Rt, [Rn, <Rm #imm>]	Store Register as word	-
STRB	Rt, [Rn, <Rm #imm>]	Store Register as byte	-
STRH	Rt, [Rn, <Rm #imm>]	Store Register as halfword	-
SUB{S}	{Rd,} Rn, <Rm #imm>	Subtract	N,Z,C,V
SVC	#imm	Supervisor Call	-
SXTB	Rd, Rm	Sign extend byte	-
SXTH	Rd, Rm	Sign extend halfword	-
TST	Rn, Rm	Logical AND based test	N,Z
UXTB	Rd, Rm	Zero extend a byte	-
UXTH	Rd, Rm	Zero extend a halfword	-
WFE	-	Wait for Event	-
WFI	-	Wait for Interrupt	-

### 2.4.1 Intrinsic Functions

ISO/IEC C code cannot directly access some Cortex-M0 instructions. The intrinsic functions that can generate these instructions, provided by the CMSIS and might be provided by a C compiler are described in [Section 2.2.7](#).

## 2.5 Exception Model

This section describes the exception model. It describes:

- Exception states ([Section 2.5.1](#))
- Exception types ([Section 2.5.2](#))
- Exception handlers ([Section 2.5.3](#))
- Vector table ([Section 2.5.4](#))
- Exception priorities ([Section 2.5.5](#))
- Exception entry and return ([Section 2.5.6](#))

### 2.5.1 Exception States

Each exception is in one of the following states:

<b>Inactive</b>	The exception is not active and not pending.
<b>Pending</b>	The exception is waiting to be serviced by the processor. An interrupt request from a peripheral or from software can change the state of the corresponding interrupt to pending.
<b>Active</b>	An exception that is being serviced by the processor but has not completed. <i>Note: An exception handler can interrupt the execution of another exception handler. In this case both exceptions are in the active state.</i>
<b>Active and pending</b>	The exception is being serviced by the processor and there is a pending exception from the same source.

## 2.5.2 Exception Types

The exception types are described in [Table 2-8](#).

**Table 2-8 Exception types**

Exception Types	Descriptions
<b>Reset</b>	Reset is invoked on power up or a warm reset. The exception model treats reset as a special form of exception. When reset is asserted, the operation of the processor stops, potentially at any point in an instruction. When reset is deasserted, execution restarts from the address provided by the reset entry in the vector table. Execution restarts in Thread mode.
<b>HardFault</b>	A HardFault is an exception that occurs because of an error during normal or exception processing. HardFaults have a fixed priority of -1, meaning they have higher priority than any exception with configurable priority.
<b>SVCall</b>	A supervisor call (SVC) is an exception that is triggered by the SVC instruction. In an OS environment, applications can use SVC instructions to access OS kernel functions and device drivers.
<b>PendSV</b>	PendSV is an interrupt-driven request for system-level service. In an OS environment, use PendSV for context switching when no other exception is active.
<b>SysTick</b>	A SysTick exception is an exception the system timer generates when it reaches zero. Software can also generate a SysTick exception. In an OS environment, the processor can use this exception as system tick.
<b>Interrupt (IRQ)</b>	A interrupt, or IRQ, is an exception signalled by a peripheral, or generated by a software request. All interrupts are asynchronous to instruction execution. In the system, peripherals use interrupts to communicate with the processor.

**Table 2-9 Properties of the different exception types**

Exception number <sup>1)</sup>	IRQ number <sup>1)</sup>	Exception type	Priority	Vector address or offset <sup>2)</sup>	Activation
1	-	Reset	-3, the highest	0x00000004	Asynchronous
2	-	Reserved	-	-	-
3	-13	HardFault	-1	0x0000000C	Synchronous



**Central Processing Unit (CPU)**

**Table 2-9 Properties of the different exception types (cont'd)**

Exception number <sup>1)</sup>	IRQ number <sup>1)</sup>	Exception type	Priority	Vector address or offset <sup>2)</sup>	Activation
4-10	-	Reserved	-	-	-
11	-5	SVCall	Configurable <sup>3)</sup>	0x0000002C	Synchronous
12-13	-	Reserved	-	-	-
14	-2	PendSV	Configurable <sup>3)</sup>	0x00000038	Asynchronous
15	-1	SysTick	Configurable <sup>3)</sup>	0x0000003C	Asynchronous
16 and above	0 and above	Interrupt (IRQ)	Configurable <sup>3)</sup>	0x00000040 and above <sup>4)</sup>	Asynchronous

1) To simplify the software layer, the CMSIS only uses IRQ numbers and therefore uses negative values for exceptions other than interrupts. The IPSR returns the Exception number, see [Interrupt Program Status Register](#).

2) See Vector table in [Section 2.5.4](#) for more information.

3) See Interrupt Priority Registers in Interrupt System chapter.

4) Increasing in steps of 4.

For an asynchronous exception, other than reset, the processor can execute additional instructions between when the exception is triggered and when the processor enters the exception handler.

Software can disable the exceptions in [Table 2-9](#) which have configurable priority, see Interrupt Clear-enable Register in Interrupt System chapter.

For more information about HardFaults, see Fault handling in [Section 2.6](#).

### 2.5.3 Exception Handlers

The processor handles exceptions using:

**Interrupt Service Routines (ISRs)**      Interrupts IRQ0 to IRQ31 are the exceptions handled by ISRs.

**Fault handlers**                      HardFault is the only exception handled by the fault handler.

**System handlers**                  PendSV, SVCall, SysTick, and the HardFault are all system exceptions that are handled by system handlers.

### 2.5.4 Vector Table

The vector table contains the reset value of the stack pointer, and the start addresses, also called exception vectors, for all exception handlers. [Figure 2-6](#) shows the order of

**Central Processing Unit (CPU)**

the exception vectors in the vector table. The least-significant bit of each vector must be 1, indicating that the exception handler is written in Thumb code.

Exception number	IRQ number	Offset	Vector
47	31	0x00BC	IRQ31
.	.	.	.
.	.	.	.
18	2	0x0048	IRQ2
17	1	0x0044	IRQ1
16	0	0x0040	IRQ0
15	-1	0x003C	Systick
14	-2	0x0038	PendSV
13			Reserved
12			
11	-5	0x002C	SVCall
10			
9			
8			
7			Reserved
6			
5			
4			
3	-13	0x0010	Hard fault
2		0x000C	Reserved
1		0x0004	Reset
		0x0000	Initial SP value

**Figure 2-6 Vector table**

The vector table is fixed at address 0x00000000.

**2.5.4.1 Vector Table Remap**

In XMC1200, the vector table is located inside the ROM. Therefore, the vector table is remapped to the SRAM based on the mapping shown in [Table 2-10](#). The user application uses these locations as entry points for the actual exception and interrupt handlers. This is done by placing the code for these handlers or having the branch instruction to the handlers there.

**Central Processing Unit (CPU)**

For example, upon an exception entry due to IRQ0, the processor reads the intermediate handler start address 2000'0040<sub>H</sub> (fixed in ROM) from the vector table and starts execution from there. If the actual handler is located in another address location due to size constraints, the address 2000'0040<sub>H</sub> should trigger a load and a branch instruction to jump to this new location.

*Note: The user application needs to reserve the SRAM addresses 2000'000C<sub>H</sub> - 2000'00BF<sub>H</sub> for the remapped vector table if all vectors are used.*

**Table 2-10 Remapped Vector Table**

Exception Number	IRQ Number	Vector	Default Vector Address	Remapped Vector Address
-	-	Initial SP Value	0000'0000 <sub>H</sub>	1000'1000 <sub>H</sub>
1	-	Reset	0000'0004 <sub>H</sub>	1000'1004 <sub>H</sub> <sup>1)</sup>
3	-13	HardFault	0000'000C <sub>H</sub>	2000'000C <sub>H</sub>
11	-5	SVCall	0000'002C <sub>H</sub>	2000'002C <sub>H</sub>
14	-2	PendSV	0000'0038 <sub>H</sub>	2000'0038 <sub>H</sub>
15	-1	SysTick	0000'003C <sub>H</sub>	2000'003C <sub>H</sub>
16-47	0-31	IRQn (n=0-31)	0000'0040 <sub>H</sub> + (n*4)	2000'0040 <sub>H</sub> + (n*4)

1) The remapped reset vector address refers to the location (start of the Flash memory) that the startup software jumps to upon exiting the startup sequence in user mode.

### 2.5.5 Exception Priorities

**Table 2-9** shows that all exceptions have an associated priority, with:

- a lower priority value indicating a higher priority
- configurable priorities for all exceptions except Reset and HardFault.

If software does not configure any priorities, then all exceptions with a configurable priority have a priority of 0. For information about configuring exception priorities see

- System Handler Priority Registers **SHPR2**, **SHPR3**.
- Interrupt Priority Registers in Interrupt System chapter.

*Note: Configurable priority values are in the range 0-192, in steps of 64. This means that the Reset and HardFault exceptions, with fixed negative priority values, always have higher priority than any other exception.*

For example, assigning a higher priority value to IRQ[0] and a lower priority value to IRQ[1] means that IRQ[1] has higher priority than IRQ[0]. If both IRQ[1] and IRQ[0] are asserted, IRQ[1] is processed before IRQ[0].

**Central Processing Unit (CPU)**

If multiple pending exceptions have the same priority, the pending exception with the lowest exception number takes precedence. For example, if both IRQ[0] and IRQ[1] are pending and have the same priority, then IRQ[0] is processed before IRQ[1].

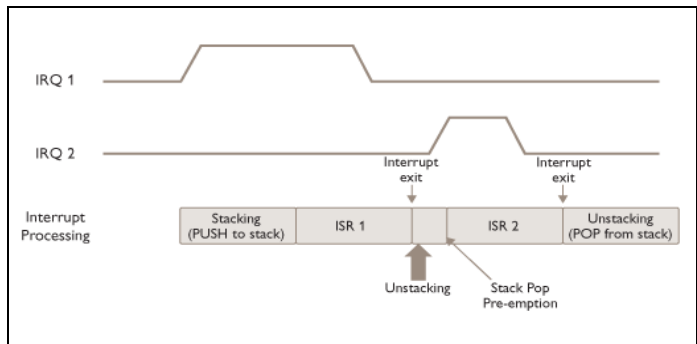
When the processor is executing an exception handler, the exception handler is preempted if a higher priority exception occurs. If an exception occurs with the same priority as the exception being handled, the handler is not preempted, irrespective of the exception number. However, the status of the new interrupt changes to pending.

**2.5.6 Exception Entry and Return**

Exception handling can be described using the following terms:

**Preemption**

When the processor is executing an exception handler, an exception can preempt the exception handler if its priority is higher than the priority of the exception being handled. When one exception preempts another, the exceptions are called nested exceptions. See Exception entry in [Section 2.5.6.1](#) for more information.



Source of figure [\[4\]](#).

**Return**

This occurs when the exception handler is completed, and:

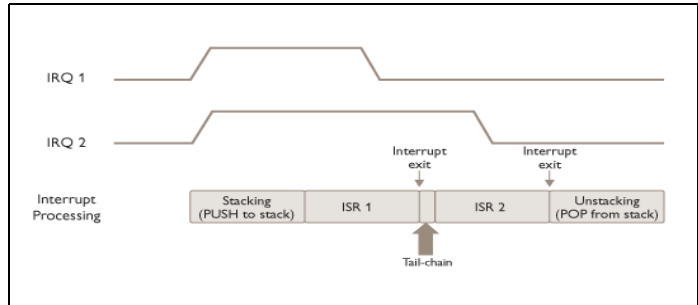
- there is no pending exception with sufficient priority to be serviced
- the completed exception handler was not handling a late-arriving exception.

The processor pops the stack and restores the processor state to the state it had before the interrupt occurred. See Exception return in [Section 2.5.6.2](#) for more information.

**Central Processing Unit (CPU)**

**Tail-chaining**

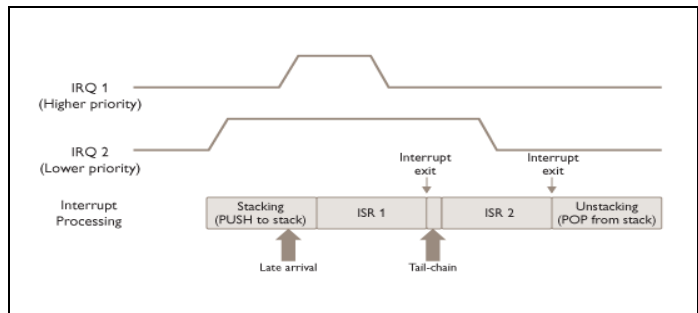
This mechanism speeds up exception servicing. On completion of an exception handler, if there is a pending exception that meets the requirements for exception entry, the stack pop is skipped and control transfers to the new exception handler.



Source of figure [4].

**Late-arriving**

This mechanism speeds up preemption. If a higher priority exception occurs during state saving for a previous exception, the processor switches to handle the higher priority exception and initiates the vector fetch for that exception. State saving is not affected by late arrival because the state saved is the same for both exceptions. On return from the exception handler of the late-arriving exception, the normal tail-chaining rules apply.



Source of figure [4].

**2.5.6.1 Exception entry**

Exception entry occurs when there is a pending exception with sufficient priority and either:

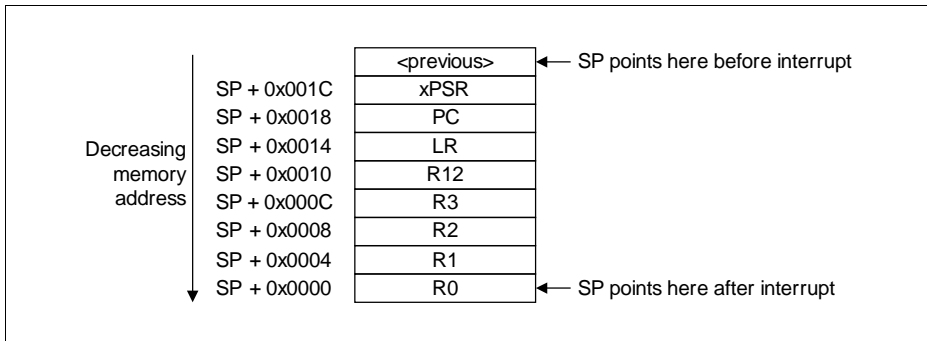
**Central Processing Unit (CPU)**

- the processor is in Thread mode
- the new exception is of higher priority than the exception being handled, in which case the new exception preempts the original exception.

When one exception preempts another, the exceptions are nested.

Sufficient priority means the exception has greater priority than any limits set by the mask register, see **Exception mask registers**. An exception with less priority than this is pending but is not handled by the processor.

When the processor takes an exception, unless the exception is a tail-chained or a late-arriving exception, the processor pushes information onto the current stack. This operation is referred to as stacking and the structure of eight data words is referred to as a stack frame. The stack frame contains the following information, as illustrated in **Figure 2-7**.



**Figure 2-7 Exception stack frame**

Immediately after stacking, the stack pointer indicates the lowest address in the stack frame. The stack frame is aligned to a double-word address.

The stack frame includes the return address. This is the address of the next instruction in the interrupted program. This value is restored to the PC at exception return so that the interrupted program resumes.

The processor performs a vector fetch that reads the exception handler start address from the vector table. When stacking is complete, the processor starts executing the exception handler. At the same time, the processor writes an EXC\_RETURN value to the LR. This indicates which stack pointer corresponds to the stack frame and what operation mode the processor was in before the entry occurred.

If no higher priority exception occurs during exception entry, the processor starts executing the exception handler and automatically changes the status of the corresponding pending interrupt to active.

**Central Processing Unit (CPU)**

If another higher priority exception occurs during exception entry, the processor starts executing the exception handler for this exception and does not change the pending status of the earlier exception. This is the late arrival case.

**2.5.6.2 Exception return**

Exception return occurs when the processor is in Handler mode and execution of one of the following instructions attempts to set the PC to an EXC\_RETURN value:

- a POP instruction that loads the PC
- a BX instruction using any register.

The processor saves an EXC\_RETURN value to the LR on exception entry. The exception mechanism relies on this value to detect when the processor has completed an exception handler. Bits [31:4] of an EXC\_RETURN value are set to 1. When this value is loaded into the PC, the processor detects that the exception is complete, and starts the exception return sequence. Bits [3:0] of the EXC\_RETURN value indicate the required return stack and processor mode. [Table 2-11](#) shows the EXC\_RETURN values with description of the exception return behavior.

**Table 2-11 Exception return behavior**

<b>EXC_RETURN[31:0]</b>	<b>Description</b>
0xFFFFFFFF1	Return to Handler mode. Exception return gets state from the main stack. Execution uses MSP after return.
0xFFFFFFFF9	Return to Thread mode. Exception return gets state from MSP. Execution uses MSP after return.
0xFFFFFFFFD	Return to Thread mode. Exception return gets state from the PSP. Execution uses PSP after return.
All other values	Reserved.

## **2.6 Fault Handling**

Faults are a subset of the exceptions, see Exception model in [Section 2.5](#). All faults result in the HardFault exception being taken or cause lockup if they occur in the HardFault handler. The faults are:

- execution of an SVC instruction at a priority equal or higher than SVCall
- execution of a BKPT instruction without a debugger attached
- a system-generated bus error on a load or store
- execution of an instruction from an XN memory address
- execution of an instruction from a location for which the system generates a bus fault
- a system-generated bus error on a vector fetch
- execution of an undefined instruction
- execution of an instruction when not in Thumb-State as a result of the T-bit being previously cleared to 0
- an attempted load or store to an unaligned address

*Note: Only Resetcan preempt the fixed priority HardFault handler. A HardFault can preempt any exception other than Reset, or another hard fault.*

### **2.6.1 Lockup**

The processor enters a lockup state if a fault occurs when executing the HardFault handlers, or if the system generates a bus error when unstacking the PSR on an exception return using the MSP. When the processor is in lockup state it does not execute any instructions. The processor remains in lockup state until one of the following occurs:

- it is reset
- it is halted by a debugger



## 2.7 Power Management

The Cortex-M0 processor sleep modes reduce power consumption:

- Sleep mode
- Deep sleep mode

The SLEEPDEEP bit of the SCR selects which sleep mode is used, see System Control Register [SCR](#).

This section describes the mechanisms for entering sleep mode, and the conditions for waking up from sleep mode.

### 2.7.1 Entering Sleep Mode

This section describes the mechanisms software can use to put the processor into sleep mode.

The system can generate spurious wakeup events, for example a debug operation wakes up the processor. Therefore software must be able to put the processor back into sleep mode after such an event. A program might have an idle loop to put the processor back to sleep mode.

#### Wait for interrupt

The wait for interrupt instruction, WFI, causes immediate entry to sleep mode. When the processor executes a WFI instruction it stops executing instructions and enters sleep mode.

#### Wait for event

The wait for event instruction, WFE, causes entry to sleep mode depending on the value of a one-bit event register. When the processor executes a WFE instruction, it checks the value of the event register:

- 0 The processor stops executing instructions and enters sleep mode.
- 1 The processor clears the register to 0 and continues executing instructions without entering sleep mode.

If the event register is 1, this indicates that the processor must not enter sleep mode on execution of a WFE instruction. Typically, this is because an external event is asserted. Software cannot access this register directly.

#### Sleep-on-exit

If the SLEEPONEXIT bit of the SCR is set to 1, when the processor completes the execution of an exception handler and returns to Thread mode, it immediately enters sleep mode. This mechanism is used in applications that only require the processor to run when an interrupt occurs.

## 2.7.2 Wakeup from Sleep Mode

The conditions for the processor to wakeup depend on the mechanism that caused it to enter sleep mode.

### Wakeup from WFI or Sleep-on-exit

The following events are WFI wake-up events:

- reset event
- debug event, if debug is enabled
- exception at a priority that would preempt any currently active exceptions, if PRIMASK was set to 0

*Note: If PRIMASK is set to 1, an interrupt or exception that has a higher priority than the current exception priority will cause the processor to wake up. Interrupt handler is not executed until the processor sets PRIMASK to 0. For more information about PRIMASK, see [Exception mask registers](#).*

### Wakeup from WFE

The following events are WFE wake-up events:

- reset event
- exception or interrupt with sufficient priority to cause exception entry
- exception or interrupt entering pending state, if SEVONPEND is set to 1 (See [SCR](#))
- debug event, if debug is enabled

*Note: External events are not supported in XMC1200. Nevertheless, SEV instruction will set the event register.*

## 2.7.3 Power Management Programming Hints

ISO/IEC C cannot directly generate the WFI and WFE instructions. The CMSIS provides the following functions for these instructions:

```
void __WFE(void) // Wait for Event  
void __WFI(void) // Wait for Interrupt
```

## 2.8 Private Peripherals

The following sections are the reference material for the ARM Cortex-M0 core peripherals.

### 2.8.1 About the Private Peripherals

The address map of the Private Peripheral Bus (PPB) is:

**Table 2-12 Core peripheral register regions**

Address	Core peripheral	Description
0xE000E008-0xE000E00F	System Control Block	See <a href="#">Section 2.8.2</a> and <a href="#">Section 2.9.1</a>
0xE000E010-0xE000E01F	System timer	See <a href="#">Section 2.8.3</a> and <a href="#">Section 2.9.2</a>
0xE000E100-0xE000E4EF	Nested Vectored Interrupt Controller	See Interrupt System chapter
0xE000ED00-0xE000ED3F	System Control Block	See <a href="#">Section 2.8.2</a> and <a href="#">Section 2.9.1</a>
0xE000EF00-0xE000EF03	Nested Vectored Interrupt Controller	See Interrupt System chapter

### 2.8.2 System control block

The System Control Block (SCB) provides system implementation information, and system control. This includes configuration, control, and reporting of the system exceptions.

#### 2.8.2.1 System control block usage hints and tips

Ensure software uses aligned 32-bit word size transactions to access all the system control block registers.

### 2.8.3 System timer, SysTick

The processor has a 24-bit system timer, SysTick, that counts down from the reload value to zero, reloads, that is wraps to, the value in the SYST\_RVR register on the next clock cycle, then counts down on subsequent clock cycles.

*Note: When the processor is halted for debugging the counter does not decrement.*

### **2.8.3.1 SysTick usage hints and tips**

The interrupt controller clock updates the SysTick count. When processor clock is selected and the clock signal is stopped for low power mode, the SysTick counter stops. When external clock is selected, the clock continues to run in low power mode and SysTick can be used as a wakeup source.

Ensure software uses aligned word accesses to access the SysTick registers.

If the SysTick counter reload and current value are undefined at reset, the correct initialization sequence for the SysTick counter is:

1. Program reload value.
2. Clear current value.
3. Program Control and Status register.

## 2.9 PPB Registers

The CPU private peripherals registers base address is E000E000<sub>H</sub>.

**Table 2-13 Register Overview**

Short Name	Description	Offset Address	Access Mode		Description See
			Read	Write	
<b>System Control Space (SCS)</b>					
CPUID	CPUID Base Register	D00 <sub>H</sub>	PV, 32	PV, 32	<a href="#">Page 2-41</a>
ICSR	Interrupt Control and State Register	D04 <sub>H</sub>	PV, 32	PV, 32	<a href="#">Page 2-42</a>
AIRCR	Application Interrupt and Reset Control Register	D0C <sub>H</sub>	PV, 32	PV, 32	<a href="#">Page 2-45</a>
SCR	System Control Register	D10 <sub>H</sub>	PV, 32	PV, 32	<a href="#">Page 2-46</a>
CCR	Configuration and Control Register	D14 <sub>H</sub>	PV, 32	PV, 32	<a href="#">Page 2-48</a>
SHPR2	System Handler Priority Register 2	D1C <sub>H</sub>	PV, 32	PV, 32	<a href="#">Page 2-49</a>
SHPR3	System Handler Priority Register 3	D20 <sub>H</sub>	PV, 32	PV, 32	<a href="#">Page 2-50</a>
SHCSR	System Handler Control and State Register	D24 <sub>H</sub>	PV, 32	PV, 32	<a href="#">Page 2-51</a>
<b>System Timer (SysTick)</b>					
SYST_CSR	SysTick Control and Status Register	010 <sub>H</sub>	PV, 32	PV, 32	<a href="#">Page 2-52</a>
SYST_RVR	SysTick Reload Value Register	014 <sub>H</sub>	PV, 32	PV, 32	<a href="#">Page 2-54</a>
SYST_CVR	SysTick Current Value Register	018 <sub>H</sub>	PV, 32	PV, 32	<a href="#">Page 2-55</a>
SYST_CALIB	SysTick Calibration Value Register	01C <sub>H</sub>	PV, 32	-	<a href="#">Page 2-56</a>

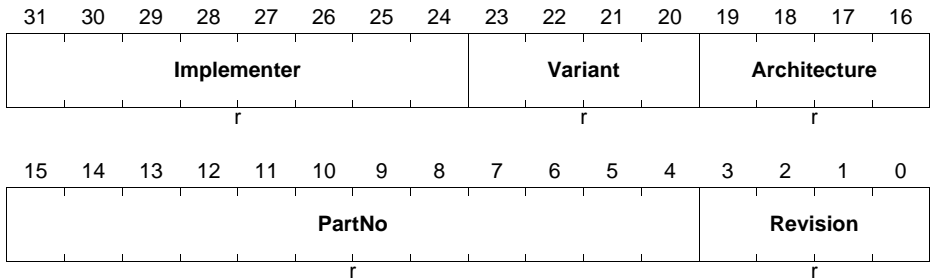
## 2.9.1 SCS Registers

### CPUID

The CPUID register contains the processor part number, version, and implementation information.

### CPUID

**CPUID Base Register (E000ED00<sub>H</sub>)**      **Reset Value: 410CC200<sub>H</sub>**



Field	Bits	Type	Description
Revision	[3:0]	r	<b>Revision Number</b> 0 <sub>H</sub> Patch 0
PartNo	[15:4]	r	<b>Part Number of the Processor</b> C20 <sub>H</sub> Cortex-M0
Architecture	[19:16]	r	<b>Architecture</b> C <sub>H</sub> ARMv6-M
Variant	[23:20]	r	<b>Variant Number</b> 0 <sub>H</sub> Revision 0
Implementer	[31:24]	r	<b>Implementer Code</b> 41 <sub>H</sub> ARM

**Central Processing Unit (CPU)**

**ICSR**

The ICSR:

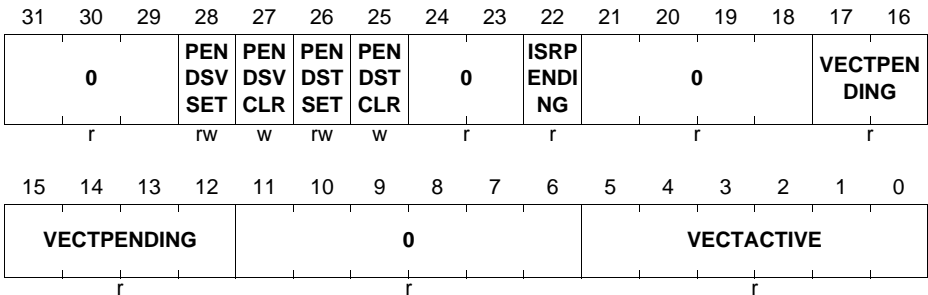
- provides:
  - set-pending and clear-pending bits for the PendSV and SysTick exceptions
- indicates:
  - the exception number of the exception being processed
  - whether there are preempted active exceptions
  - the exception number of the highest priority pending exception
  - whether any interrupts are pending.

**ICSR**

**Interrupt Control and State Register**

(E000ED04<sub>H</sub>)

Reset Value: 00000000<sub>H</sub>



Field	Bits	Type	Description
VECTACTIVE <sup>1)</sup>	[5:0]	r	<p><b>Active Exception Number</b> 00<sub>H</sub> Thread mode Non-zero value The exception number of the currently active exception.</p> <p><i>Note: Subtract 16 from this value to obtain the CMSIS IRQ number required to index into the Interrupt Clear-Enable, Set-Enable, Clear-Pending, Set-Pending, or Priority Registers, see <a href="#">Interrupt Program Status Register</a>.</i></p>
0	[11:6]	r	<p><b>Reserved</b> Read as 0; should be written with 0.</p>

**Central Processing Unit (CPU)**

Field	Bits	Type	Description
<b>VECTPENDING</b>	[17:12]	r	<b>Pending Exception Number</b> Indicates the exception number of the highest priority pending enabled exception. $0_H$ No pending exceptions Non-zero value: The exception number of the highest priority pending enabled exception.
<b>0</b>	[21:18]	r	<b>Reserved</b> Read as 0; should be written with 0.
<b>ISR_PENDING</b>	22	r	<b>Interrupt Pending Flag</b> This bit sets the interrupt pending flag, excluding faults. $0_B$ Interrupt not pending $1_B$ Interrupt pending.
<b>0</b>	[24:23]	r	<b>Reserved</b> Read as 0; should be written with 0.
<b>PENDSTCLR</b>	25	w	<b>SysTick Exception Clear-pending</b> $0_B$ No effect $1_B$ removes the pending state from the SysTick exception. This bit is write-only. On a register read, this value is unknown.
<b>PENDSTSET</b>	26	rw	<b>SysTick Exception Set-pending</b> $0_D$ SysTick exception is not pending $1_D$ SysTick exception is pending. A write of 0 to the bit has no effect.
<b>PENDSVCLR</b>	27	w	<b>PendSV Clear Pending</b> This bit clears a pending PendSV exception. $0_B$ Do not clear. $1_B$ Removes pending state from PendSV exception.
<b>PENDSVSET</b>	28	rw	<b>PendSV Set Pending</b> This bit sets a pending PendSV exception or reads back the current state. $0_B$ PendSV exception is not pending. $1_B$ PendSV exception is pending. <i>Note: Writing 1 to this bit is the only way to set the PendSV exception state to pending.</i> A software write of 0 to the bit has no effect.



**Central Processing Unit (CPU)**

Field	Bits	Type	Description
<b>0</b>	[31:29]	r	<b>Reserved</b> Read as 0; should be written with 0.

1) This is the same value as IPSR bits[5:0], see [Interrupt Program Status Register](#).

*Note: The result is unpredictable if:*

1. Both *PENDSVSET* and *PENDSVCLR* bits are set to 1.
2. Both *PENDSTSET* and *PENDSTCLR* bits are set to 1.

**Central Processing Unit (CPU)**

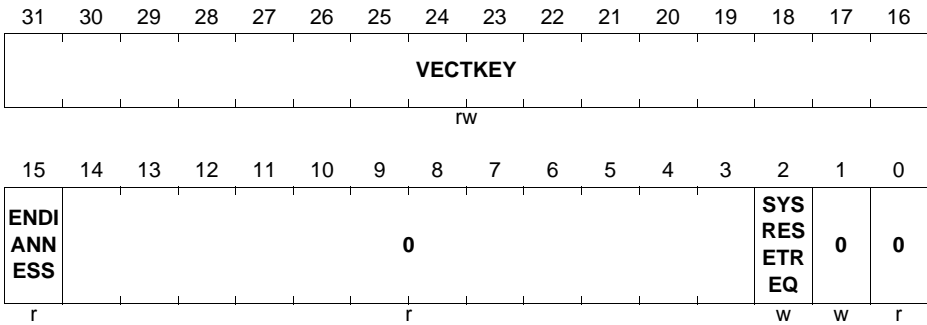
**AIRCR**

The AIRCR register provides endian status for data accesses and reset control of the system. To write to this register, you must write 0x5FA to the VECTKEY field, otherwise the processor ignores the write.

**AIRCR**

**Application Interrupt and Reset Control Register**  
**(E00ED0C<sub>H</sub>)**

**Reset Value: FA050000<sub>H</sub>**



Field	Bits	Type	Description
<b>0</b>	0	r	<b>Reserved</b> Read as 0; should be written with 0.
<b>0</b>	1	w	<b>Reserved</b> Must be written with 0.
<b>SYSRESETEQ</b>	2	w	<b>System Reset Request</b> 0 <sub>B</sub> No effect. 1 <sub>B</sub> Requests a system level reset. This bit is read as 0.
<b>0</b>	[14:3]	r	<b>Reserved</b> Read as 0; should be written with 0.
<b>ENDIANNESS</b>	15	r	<b>Data Endianness</b> 0 <sub>B</sub> Little-endian
<b>VECTKEY</b>	[31:16]	rw	<b>Register Key</b> Reads as unknown. On writes, write 0x5FA to VECTKEY, otherwise the write is ignored.

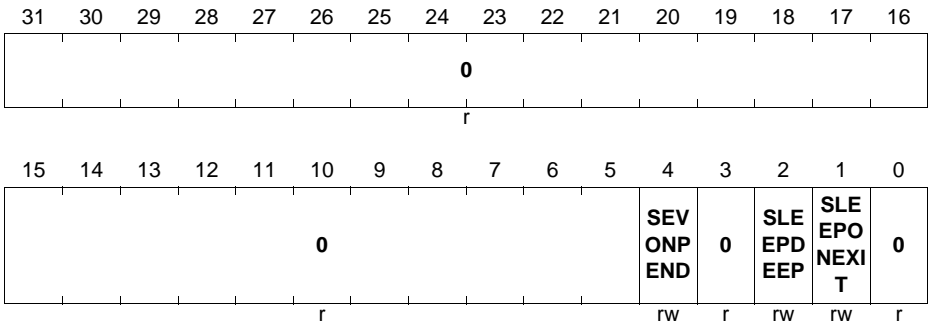
**Central Processing Unit (CPU)**

**SCR**

The SCR controls features of entry to and exit from low power state.

**SCR**

**System Control Register (E000ED10<sub>H</sub>) Reset Value: 00000000<sub>H</sub>**



Field	Bits	Type	Description
<b>0</b>	0	r	<b>Reserved</b> Read as 0; should be written with 0.
<b>SLEEPONEXIT</b>	1	rw	<b>Sleep-on-exit</b> This bit indicates sleep-on-exit when returning from Handler mode to Thread mode. $0_B$ Do not sleep when returning to Thread mode. $1_B$ Enter sleep, or deep sleep, on return from an ISR to Thread mode. Setting this bit to 1 enables an interrupt driven application to avoid returning to an empty main application.
<b>SLEEPDEEP</b>	2	rw	<b>Low Power Sleep Mode</b> This bit controls whether the processor uses sleep or deep sleep as its low power mode. $0_B$ Sleep $1_B$ Deep sleep
<b>0</b>	3	r	<b>Reserved</b> Read as 0; should be written with 0.

**Central Processing Unit (CPU)**

Field	Bits	Type	Description
<b>SEVONPEND</b>	4	rw	<p><b>Send Event on Pending bit</b></p> <p>0<sub>B</sub> Only enabled interrupts or events can wakeup the processor, disabled interrupts are excluded.</p> <p>1<sub>B</sub> Enabled events and all interrupts, including disabled interrupts, can wakeup the processor. When an event or interrupt enters pending state, the event signal wakes up the processor from WFE. If the processor is not waiting for an event, the event is registered and affects the next WFE.</p>
<b>0</b>	[31:5]	r	<p><b>Reserved</b></p> <p>Read as 0; should be written with 0.</p>

**Central Processing Unit (CPU)**

**CCR**

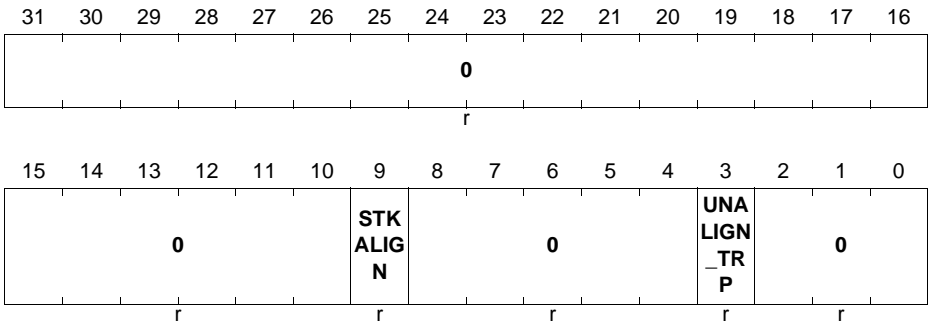
The CCR is a read-only register and it indicates some aspects of the behavior of the Cortex-M0 processor.

**CCR**

**Configuration and Control Register**

(E000ED14<sub>H</sub>)

Reset Value: 00000208<sub>H</sub>



Field	Bits	Type	Description
<b>0</b>	[2:0]	r	<b>Reserved</b> Read as 0; should be written with 0.
<b>UNALIGN_TRP</b>	3	r	<b>Unaligned Access Traps</b> This bit always reads as 1, indicates that all unaligned accesses generate a HardFault.
<b>0</b>	[8:4]	r	<b>Reserved</b> Read as 0; should be written with 0.
<b>STKALIGN</b>	9	r	<b>Stack Alignment</b> This bit always reads as 1, indicates 8-byte stack alignment on exception entry. On exception entry, the processor uses bit [9] of the stacked PSR to indicate the stack alignment. On return from the exception, it uses this stacked bit to restore the correct stack alignment.
<b>0</b>	[31:10]	r	<b>Reserved</b> Read as 0; should be written with 0.

### System Handler Priority Registers

The SHPR2-SHPR3 registers set the priority level, 0 to 192, of the exception handlers that have configurable priority.

SHPR2-SHPR3 are word accessible. To access to the system exception priority level using CMSIS, the following CMSIS functions are used:

- `uint32_t NVIC_GetPriority(IRQn_Type IRQn)`
- `void NVIC_SetPriority(IRQn_Type IRQn, uint32_t priority)`

The system fault handlers, the priority field and register for each handler are:

**Table 2-14 System fault handler priority fields**

Handler	Field	Register description
SVCcall	PRI_11	System Handler Priority Register 2 on <a href="#">Page 2-49</a>
PendSV	PRI_14	System Handler Priority Register 3 on <a href="#">Page 2-50</a>
SysTick	PRI_15	

Each PRI\_N field is 8 bits wide, but the XMC1200 implements only bits [7:6] of each field, and bits [5:0] read as zero and ignore writes.

### SHPR2

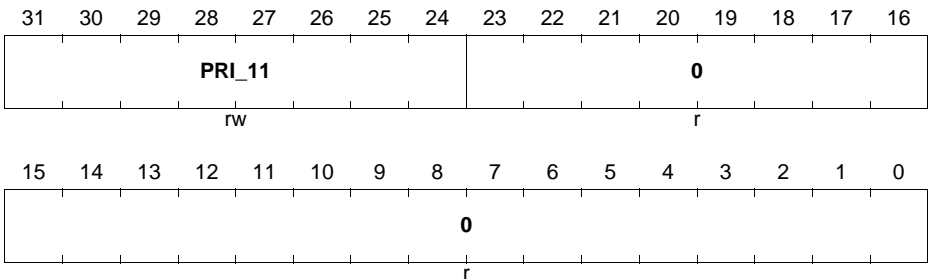
The SHPR2 register sets the priority level for the SVCcall handler.

### SHPR2

#### System Handler Priority Register 2

(E000ED1C<sub>H</sub>)

Reset Value: 00000000<sub>H</sub>



Field	Bits	Type	Description
<b>0</b>	[23:0]	r	<b>Reserved</b> Read as 0; should be written with 0.
<b>PRI_11</b>	[31:24]	rw	<b>Priority of System Handler 11</b> SVCall.

### SHPR3

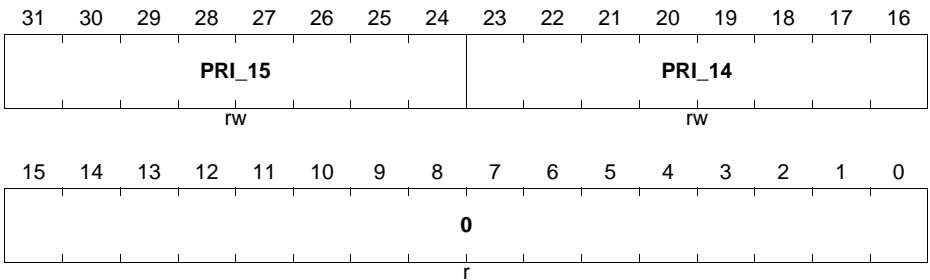
The SHPR3 register sets the priority level for the PendSV and SysTick handlers.

### SHPR3

#### System Handler Priority Register 3

(E000ED20<sub>H</sub>)

Reset Value: 00000000<sub>H</sub>



Field	Bits	Type	Description
<b>0</b>	[15:0]	r	<b>Reserved</b> Read as 0; should be written with 0.
<b>PRI_14</b>	[23:16]	rw	<b>Priority of System Handler 14</b> PendSV.
<b>PRI_15</b>	[31:24]	rw	<b>Priority of System Handler 15</b> SysTick exception.

**SHCSR**

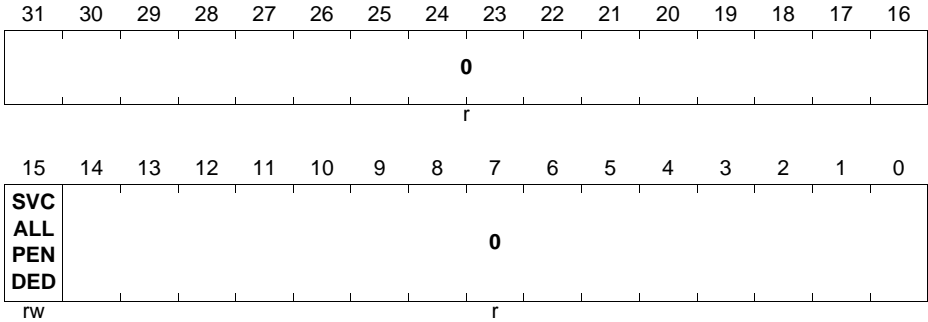
The SHCSR register controls and provides the status of system handlers.

**SHCSR**

**System Handler Control and State Register**

(E000ED24<sub>H</sub>)

Reset Value: 00000000<sub>H</sub>



Field	Bits	Type	Description
<b>0</b>	[14:0]	r	<b>Reserved</b> Read as 0; should be written with 0.
<b>SVCALLPENDE</b>	15	rw	<b>SVCAll Pending bit</b> This bit reflects the pending state on a read, and updates the pending state, to the value written, on a write. 0 <sub>B</sub> SVCAll is not pending. 1 <sub>B</sub> SVCAll is pending <sup>1)</sup> .
<b>0</b>	[31:16]	r	<b>Reserved</b> Read as 0; should be written with 0.

1) Pending state bits are set to 1 when an exception occurs, and are cleared to 0 when an exception becomes active.



## 2.9.2 SysTick Registers

### SYST\_CSR

The SYST\_CSR register enables the SysTick features.

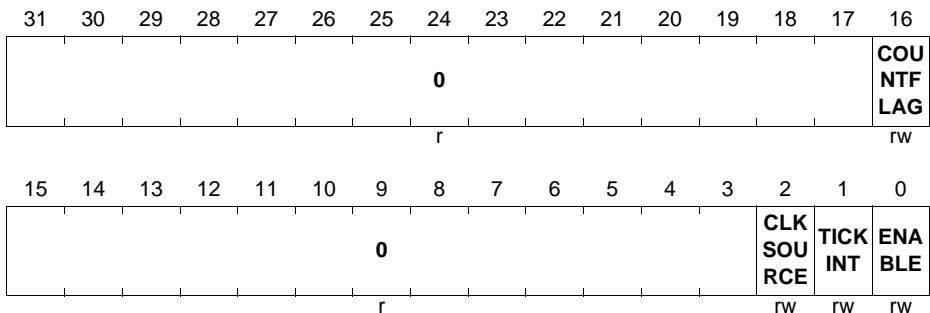
Reading SYST\_CSR clears the COUNTFLAG bit to 0.

### SYST\_CSR

#### SysTick Control and Status Register

(E000E010<sub>H</sub>)

Reset Value: 00000000<sub>H</sub>



Field	Bits	Type	Description
<b>ENABLE</b>	0	rw	<b>Counter Enable</b> This bit enables the counter. 0 <sub>B</sub> Counter disabled. 1 <sub>B</sub> Counter enabled.
<b>TICKINT</b>	1	rw	<b>SysTick Exception Request</b> This bit enables the SysTick exception request. 0 <sub>B</sub> Counting down to zero does not assert the SysTick exception request. 1 <sub>B</sub> Counting down to zero to assert the SysTick exception request. In software, COUNTFLAG bit can be used to determine if SysTick has counted to zero.
<b>CLKSOURCE</b>	2	rw	<b>Clock Source</b> This bit selects the SysTick timer clock source. 0 <sub>B</sub> External clock <sup>1)</sup> . 1 <sub>B</sub> Processor clock.

**Central Processing Unit (CPU)**

Field	Bits	Type	Description
<b>0</b>	[15:3]	r	<b>Reserved</b> Read as 0; should be written with 0.
<b>COUNTFLAG</b>	16	rw	<b>Counter Flag</b> This bit returns 1 if timer counted to 0 since the last read of this register.
<b>0</b>	[31:17]	r	<b>Reserved</b> Read as 0; should be written with 0.

1) In XMC1200, the external clock refers to the on-chip 32 kHz standby clock.

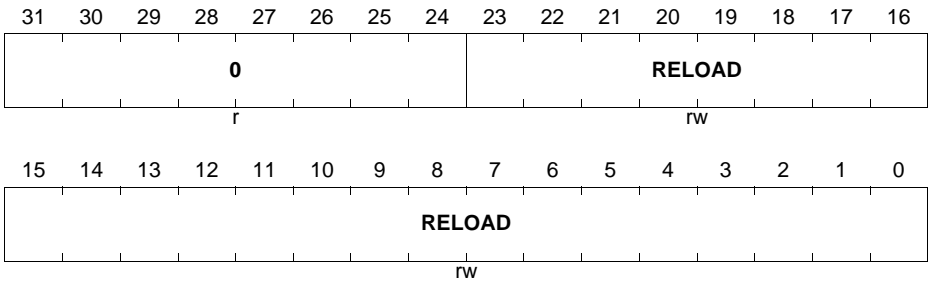
When ENABLE is set to 1, the counter loads the RELOAD value from the SYST\_RVR register and then counts down. On reaching 0, it sets the COUNTFLAG to 1 and optionally asserts the SysTick depending on the value of TICKINT. It then loads the RELOAD value again, and begins counting.

**SYST\_RVR**

The SYST\_RVR register specifies the start value to load into the SYST\_CVR register.

**SYST\_RVR**

**SysTick Reload Value Register (E000E014<sub>H</sub>)**      **Reset Value: XXXXXXXX<sub>H</sub>**



Field	Bits	Type	Description
<b>RELOAD</b>	[23:0]	rw	<b>Reload Value</b> This field sets the value to load into the SYST_CVR register when the counter is enabled and when it reaches 0.
<b>0</b>	[31:24]	r	<b>Reserved</b> Read as 0; should be written with 0.

**Notes on calculating the RELOAD value**

1. The RELOAD value can be any value in the range 0x00000001-0x00FFFFFF. A start value of 0 is possible, but this has no effect because the SysTick exception request and COUNTFLAG are activated when counting from 1 to 0.
2. The RELOAD value is calculated according to its use. For example, to generate a multi-shot timer with a period of N processor clock cycles, use a RELOAD value of N-1. If the SysTick interrupt is required every 100 clock pulses, set RELOAD to 99.

**Central Processing Unit (CPU)**

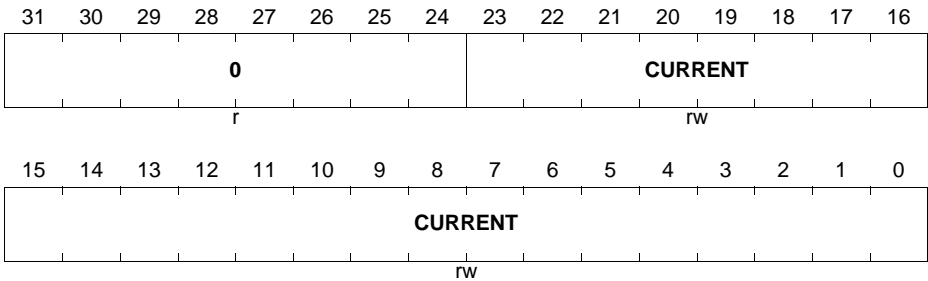
**SYST\_CVR**

The SYST\_CVR register contains the current value of the SysTick counter.

Writing to the SYST\_CVR clears the register and the COUNTFLAG status bit to 0. The write does not trigger the SysTick exception logic. Reading the register returns its value at the time it is accessed.

**SYST\_CVR**

**SysTick Current Value Register (E000E018<sub>H</sub>)**      **Reset Value: XXXXXXXX<sub>H</sub>**



Field	Bits	Type	Description
<b>CURRENT</b>	[23:0]	rw	<b>SysTick Counter Current Value</b> When read, it returns the current value of the SysTick counter. A write of any value clears the field to 0, and also clears the SYST_CSR.COUNTFLAG bit to 0.
<b>0</b>	[31:24]	r	<b>Reserved</b> Read as 0; should be written with 0.

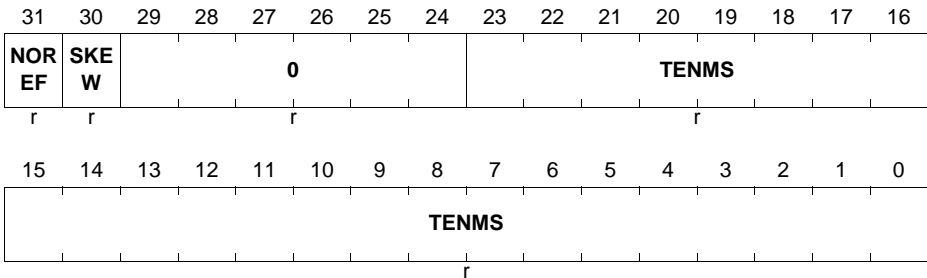
**SYST\_CALIB**

The SYST\_CALIB register indicates the SysTick calibration properties.

**SYST\_CALIB**

**SysTick Calibration Value Register(E000E01C<sub>H</sub>)**

**Reset Value: 40000147<sub>H</sub>**



Field	Bits	Type	Description
<b>TENMS</b>	[23:0]	r	<b>10 Milliseconds</b> The reload value for 10ms timing is subject to system clock skew errors. The default value of TENMS is 0x000147.
<b>0</b>	[29:24]	r	<b>Reserved</b> Read as 0; should be written with 0.
<b>SKEW</b>	30	r	<b>Clock Skew</b> This bit is read as 1. It indicates that 10ms calibration value is inexact, because of the clock frequency.
<b>NOREF</b>	31	r	<b>Reference Clock</b> This bit is read as 0. It indicates that external reference clock is provided.

## **3 Bus System**

The single master bus system in XMC1200 consists of a high-performance system bus based on the industry AMBA 3 AHB-Lite Protocol standard for memories and high-bandwidth on-chip peripherals and a narrower APB for low-bandwidth on-chip peripherals.

### **3.1 Bus Interfaces**

This chapter describes the features for the two kinds of interfaces.

- Memory Interface
- Peripheral Interface

All on-chip modules implement Little Endian data organization.

#### **Memory Interface**

The on-chip memories are capable to accept a transfer request with each bus clock cycle.

The memory interface data bus width is 32-bit. Flash memory supports only 32-bit accesses while SRAM allows 32-bit, 16-bit and 8-bit write accesses. Read accesses to SRAM is always 32-bit wide.

#### **Peripheral Interface**

Each slave on the AHB-Lite supports 32-bit accesses. Additionally:

- USIC0 supports 8-bit and 16-bit accesses

Each slave on the APB supports only 16-bit accesses.

*Note: Unaligned memory accesses to memory or peripheral slaves result in a HardFault exception.*

## 4 Service Request Processing

A hardware pulse is called Service Request (SR) in an XMC1200 system. Service Requests are the fastest way to send trigger “messages” between connected on-chip resources.

An SR can generate any of the following requests

- Interrupt
- Peripheral action

This chapter describes the available Service Requests and the different ways to select and process them.

**Table 4-1 Abbreviations**

ERU	Event Request Unit
NVIC	Nested Vectored Interrupt Controller
SR	Service Request

### 4.1 Overview

Efficient Service Request Processing is based on the interconnect between the request sources and the request processing units. XMC1200 provides both fixed and programmable interconnect.

#### 4.1.1 Features

The following features are provided for Service Request processing:

- Connectivity matrix between Service Requests and request processing units
  - Fixed connections
  - Programmable connections using ERU

#### 4.1.2 Block Diagram

**Figure 4-1** shows a representation of the interaction between the request sources and the request processing units.

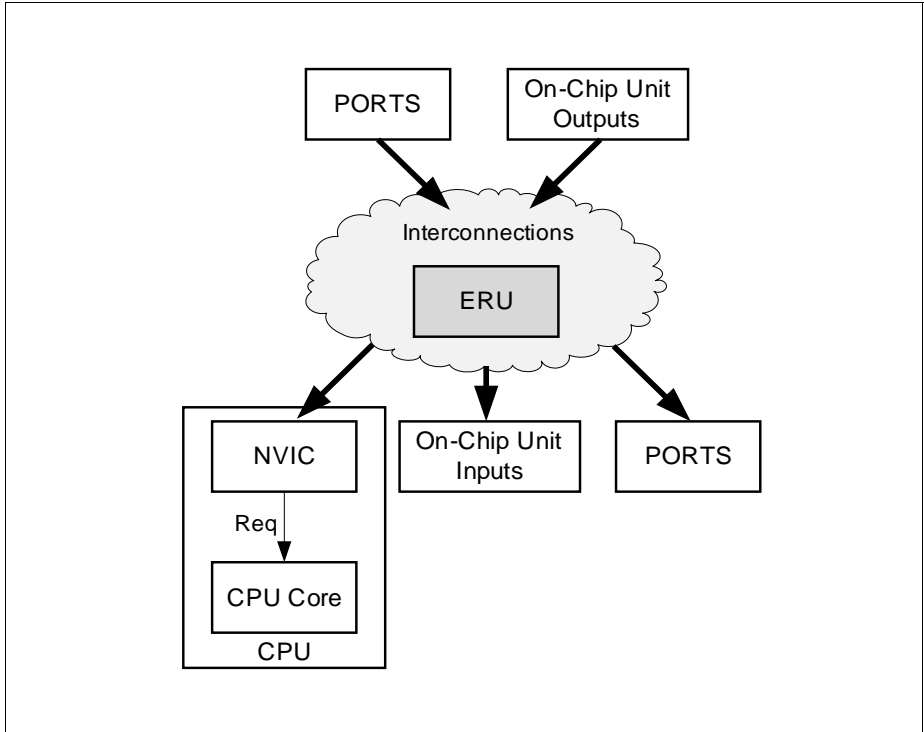
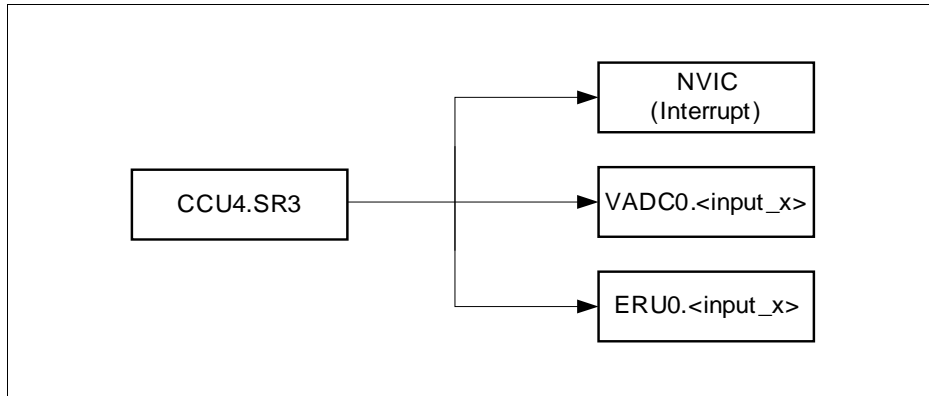


Figure 4-1 Block Diagram on Service Request Processing



## 4.2 Service Request Distribution

**Figure 4-2** shows an example of how a service request can be distributed concurrently. To support the concurrent distribution to multiple receivers, the receiving modules are capable to enable/disable incoming requests.



**Figure 4-2 Example for Service Request Distribution**

The units involved in Service Request distribution can be subdivided into

- Embedded real time services
- Interrupt services

### Embedded real time services

Connectivity between On-Chip Units and PORTS is real time application and also chip package dependant. Related connectivity and availability of pins can be looked up in the

- “Interconnects” Section of the respective module(s) chapters
- “Parallel Ports” chapter and Data Sheet for PORTS
- “Event Request Unit” chapter

### Interrupt services

The following table gives an overview on the number of service requests per module and how the service requests are assigned to NVIC Interrupt service provider.

Service Requests are always of type “Pulse” in XMC1200.

**Table 4-2 Interrupt services per module**

<b>Modules</b>	<b>Request Sources</b>	<b>NVIC</b>	<b>Type</b>
VADC	12	6	Pulse
CCU40	4	4	Pulse
USIC0	6	6	Pulse
LEDTS0-1	2	2	Pulse
BCCU0	1	1	Pulse
SCU	3	3	Pulse
ERU0	4	4	Pulse
Total	32	26	-

## 5 Interrupt Subsystem

The interrupt Subsystem in XMC1200 consists of the Nested Vectored Interrupt Controller (NVIC) and the respective modules' interrupt generation blocks.

*Note: The CPU exception model is described in the CPU chapter.*

### 5.1 Nested Vectored Interrupt Controller (NVIC)

The NVIC is an integral part of the Cortex M0 processor unit. Due to a tight coupling with the CPU, it provides the lowest interrupt latency and efficient processing of late arriving interrupts.

#### 5.1.1 Features

The NVIC supports the following features:

- 32 interrupt nodes
- 4 programmable priority levels for each interrupt node
- Support for interrupt tail-chaining and late-arrival
- Software interrupt generation

#### 5.1.2 Interrupt Node Assignment

**Table 5-1** lists the service request sources per peripheral and their assignment to NVIC interrupt nodes. For calculation of the vector routine address, please refer to the section on Vector Table in the CPU chapter.

**Table 5-1 Interrupt Node assignment**

Service Request	Node ID	Description
SCU.SR0 - SCU.SR2	0...2	System Control SR0 is the system critical request SR1 is the common SCU request SR2 is the comparators (ACMPx and ORCx) request
ERU0.SR0 - ERU0.SR3	3...6	External Request Unit 0
NC	7...8	Reserved
USIC0.SR0 - USIC0.SR5	9...14	Universal Serial Interface Channel (Module 0)
VADC0.C0SR0 - VADC0.C0SR1	15...16	Analog to Digital Converter (Common)
VADC0.G0SR0 - VADC0.G0SR1	17...18	Analog to Digital Converter (Group 0)

**Table 5-1 Interrupt Node assignment (cont'd)**

Service Request	Node ID	Description
VADC0.G1SR0 - VADC0.G1SR1	19...20	Analog to Digital Converter (Group 1)
CCU40.SR0 - CCU40.SR3	21...24	Capture Compare Unit 4 (Module 0)
NC	25...28	Reserved
NC	29...30	Reserved
LEDTS0.SR0	29	LED and Touch Sense Control Unit (Module 0)
LEDTS1.SR0	30	LED and Touch Sense Control Unit (Module 1)
BCCU0.SR0	31	Brightness Control Unit (Module 0)

### 5.1.3 Interrupt Signal Generation

In XMC1200, all peripherals support only the generation of pulse interrupts. Pulse interrupts are also described as edge-triggered interrupts.

A pulse interrupt is an interrupt signal sampled synchronously on the rising edge of the processor clock (MCLK). To ensure the NVIC detects the interrupt, the peripheral asserts the interrupt signal for at least one MCLK clock cycle, during which the NVIC detects the pulse and latches the interrupt.

When the processor enters the ISR, it automatically removes the pending state from the interrupt, see [Hardware and software control of interrupts](#).

The processor automatically stacks its state on exception entry and unstacks this state on exception exit, with no instruction overhead. This provides low latency exception handling.

#### Hardware and software control of interrupts

The Cortex-M0 latches all interrupts. A peripheral interrupt becomes pending for one of the following reasons:

- the NVIC detects that the interrupt signal is active and the interrupt is not active
- the NVIC detects a rising edge on the interrupt signal
- software writes to the corresponding interrupt set-pending register bit, see Interrupt Set-pending Register NVIC\_ISPR.

A pending interrupt remains pending until one of the following:

- The processor enters the ISR for the interrupt. This changes the state of the interrupt from pending to active. Then:
  - The NVIC continues to monitor the interrupt signal, and if this is pulsed the state of the interrupt changes to pending and active. In this case, when the processor

**Interrupt Subsystem**

returns from the ISR the state of the interrupt changes to pending, which might cause the processor to immediately re-enter the ISR.

If the interrupt signal is not pulsed while the processor is in the ISR, the state of the interrupt changes to inactive when the processor returns from the ISR.

- Software writes to the corresponding interrupt clear-pending register bit.
  - The state of the interrupt changes to inactive, if the state was pending; or active, if the state was active and pending.

**5.1.4 NVIC design hints and tips**

An interrupt node can enter pending state even if it is disabled. Disabling an interrupt node only prevents the processor from taking interrupts from that node.

**NVIC programming hints**

Software uses the CPSIE i and CPSID i instructions to enable and disable interrupts. The CMSIS provides the following intrinsic functions for these instructions:

```
void __disable_irq(void) // Disable Interrupts
void __enable_irq(void) // Enable Interrupts
```

In addition, the CMSIS provides a number of functions for NVIC control, including:

**Table 5-2 CMSIS functions for NVIC control**

<b>CMSIS interrupt control function</b>	<b>Description</b>
void NVIC_EnableIRQ (IRQn_t IRQn)	Enable IRQn
void NVIC_DisableIRQ (IRQn_t IRQn)	Disable IRQn
uint32_t NVIC_GetPendingIRQ (IRQn_t IRQn)	Return true (1) if IRQn is pending
void NVIC_SetPendingIRQ (IRQn_t IRQn)	Set IRQn pending
void NVIC_ClearPendingIRQ (IRQn_t IRQn)	Clear IRQn pending status
void NVIC_SetPriority (IRQn_t IRQn, uint32_t priority)	Set priority for IRQn
uint32_t NVIC_GetPriority (IRQn_t IRQn)	Read priority of IRQn
void NVIC_SystemReset (void)	Reset the system

The input parameter IRQn is the IRQ number. For more information about these functions, please refer to the CMSIS documentation.

### 5.1.5 Accessing CPU Registers using CMSIS

CMSIS functions enable software portability between different Cortex-M profile processors. To access the NVIC registers when using CMSIS, use the following functions:

**Table 5-3 CMSIS access NVIC functions**

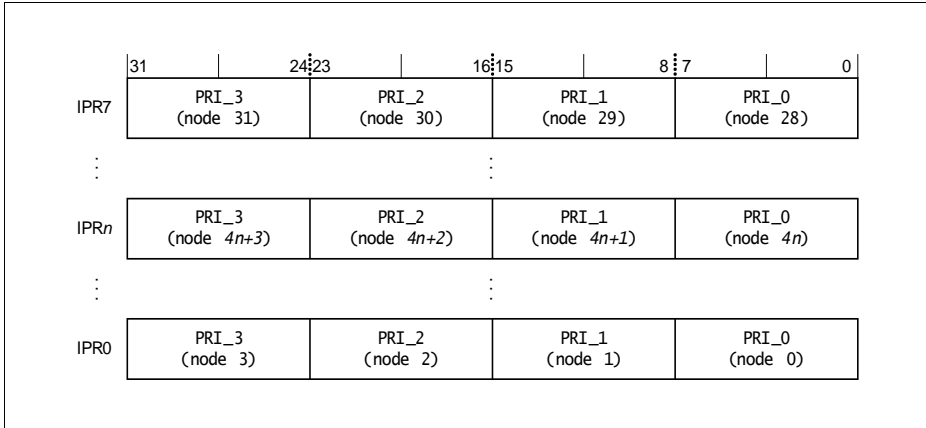
<b>CMSIS function</b>	<b>Description</b>
<code>void NVIC_EnableIRQ (IRQn_Type IRQn)<sup>1)</sup></code>	Enables an interrupt or exception.
<code>void NVIC_DisableIRQ (IRQn_Type IRQn)<sup>1)</sup></code>	Disables an interrupt or exception.
<code>void NVIC_SetPendingIRQ (IRQn_Type IRQn)<sup>1)</sup></code>	Sets the pending status of interrupt or exception to 1.
<code>void NVIC_ClearPendingIRQ (IRQn_Type IRQn)<sup>1)</sup></code>	Clears the pending status of interrupt or exception to 0.
<code>uint32_t NVIC_GetPendingIRQ (IRQn_Type IRQn)<sup>1)</sup></code>	Reads the pending status of interrupt or exception. This function returns non-zero value if the pending status is set to 1.
<code>void NVIC_SetPriority(IRQn_Type IRQn, uint32_t priority)<sup>1)</sup></code>	Sets the priority of an interrupt or exception with configurable priority level to 1.
<code>uint32_t NVIC_GetPriority(IRQn_Type IRQn)<sup>1)</sup></code>	Reads the priority of an interrupt or exception with configurable priority level. This function return the current priority level.

1) The input parameter IRQn is the IRQ number.

### 5.1.6 Interrupt Priority

An interrupt node can be assigned one of four priority levels. The levels are in steps of 64, from 0 to 192, and defined in an 8-bit priority field in the Interrupt Priority Register x (IPRx). A higher level corresponds to a lower priority, so level 0 is the highest interrupt priority.

Since there are four priority fields in each IPRx register and each field corresponds to one interrupt node, altogether 8 IPRx registers (IPR0...IPR7) are needed as shown in [Figure 5-1](#).



**Figure 5-1 Interrupt Priority Register**

The IPR number and byte offset for interrupt node  $m$  (0...31) can be found as follows:

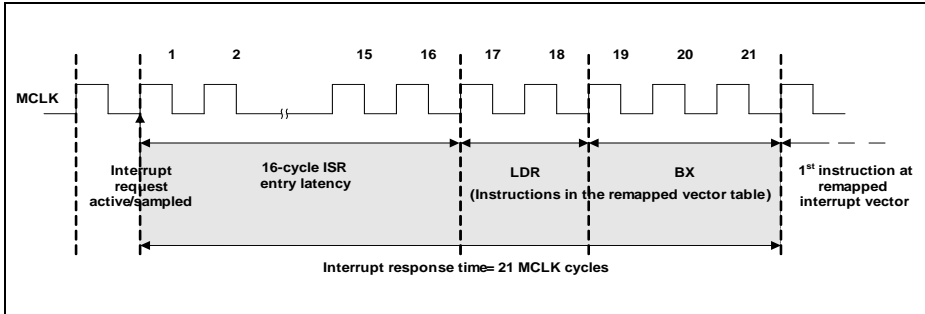
- the corresponding IPR number  $n$  is given by  
 $n = m \text{ DIV } 4$
- the byte offset of the required Priority field in this register is  $m \text{ MOD } 4$ , where:
  - byte offset 0 refers to register bits [7:0]
  - byte offset 1 refers to register bits [15:8]
  - byte offset 2 refers to register bits [23:16]
  - byte offset 3 refers to register bits [31:24]
- for example, Priority field of interrupt node 21 is located at IPR5.[15:8], since
  - $n = 21 \text{ DIV } 4 = 5$
  - byte offset =  $21 \text{ MOD } 4 = 1$

*Note: IPRx registers are only word-accessible.*

Refer to [Table 5-2](#) for more information on the access to the interrupt node priority array, which provides the software view of the interrupt node priorities.

### 5.1.7 Interrupt Response Time

The interrupt response time, defined as the time from detection of the generated pulse and latching of the interrupt by NVIC to execution of the first instruction at the interrupt handler, is typically 21 MCLK cycles as shown in [Figure 5-2](#).



**Figure 5-2 Typical Interrupt Response Time**

This assumes the following conditions:

- Interrupt generation is enabled
- No occurrence of interrupt pre-emption, late-arrival or tail-chaining
- Delays due to memory wait states are not taken into account

## 5.2 General Module Interrupt Structure

A module might have multiple interrupt sources. Each interrupt source has typically the following structure (see [Figure 5-3](#)):

- An interrupt source status flag
- A set bit to allow software to set the flag to 1
- A clear bit to allow software to reset the flag to 0
- An enable bit to trigger interrupt when the hardware event occurs or status flag set bit is set (i.e. software triggered interrupt)

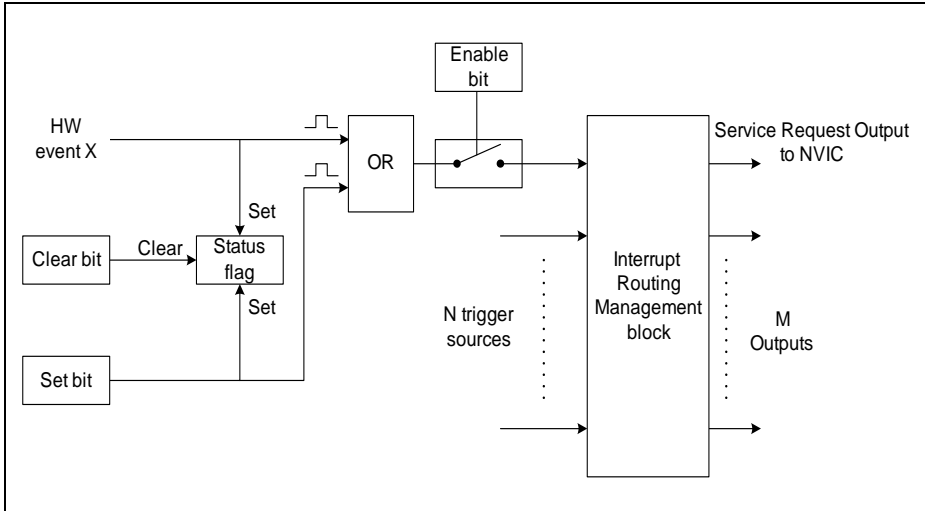
*Note: If a flag set event (due to a peripheral HW event) occurs in the same clock cycle as a flag clear event (due to SW Setting of the Clear bit), the set has higher priority over the clear.*

*Note: Setting of the status flag by a hardware event or software writing to status flag set bit, is independent of interrupt generation enabled/disabled. Similarly, interrupt generation is independent of the level of the status flag.*

Additionally, some modules might have more interrupt sources than interrupt lines. Therefore, they include an interrupt routing management block, which maps the interrupt sources to the interrupt lines.

For further details and exceptions to the above general structure, refer to the respective module chapters. An overview of all XMC1200 interrupt sources is given at the end of the chapter.





**Figure 5-3 Typical Module Interrupt Structure**

To enable a module HW event for interrupt generation, SW has to:

- Enable the interrupt node that is allocated to the module in the NVIC, through the NVIC\_IUSER register.
- If the module has an interrupt routing management block, select an available service request output through which the interrupt will be generated to the NVIC. This is usually done by configuring an interrupt node pointer register in the module.
- Finally, set the interrupt enable bit of the module HW event for interrupt generation.

### 5.3 Registers

**Table 5-4 Registers Address Space**

Module	Base Address	End Address	Note
CPU PPB: System Control Space (SCS)	E000E000 <sub>H</sub>	E000EFFF <sub>H</sub>	

#### Registers Overview

The absolute register address is calculated by adding:  
Module Base Address + Offset Address

**Table 5-5 Register Overview**

Short Name	Description	Offset Address	Access Mode		Description See
			Read	Write	
<b>Nested Vectored Interrupt Controller (NVIC)</b>					
NVIC_ISER	Interrupt Set-enable Registers	100 <sub>H</sub>	U, PV	U, PV	<a href="#">Page 5-9</a>
NVIC_ICER	Interrupt Clear-enable Registers	180 <sub>H</sub>	U, PV	U, PV	<a href="#">Page 5-10</a>
NVIC_ISPR	Interrupt Set-pending Registers	200 <sub>H</sub>	U, PV	U, PV	<a href="#">Page 5-11</a>
NVIC_ICPR	Interrupt Clear-pending Registers	280 <sub>H</sub>	U, PV	U, PV	<a href="#">Page 5-12</a>
NVIC_IPR0 - NVIC_IPR7	Interrupt Priority Registers	400 <sub>H</sub> -41C <sub>H</sub>	U, PV	U, PV	<a href="#">Page 5-13</a>

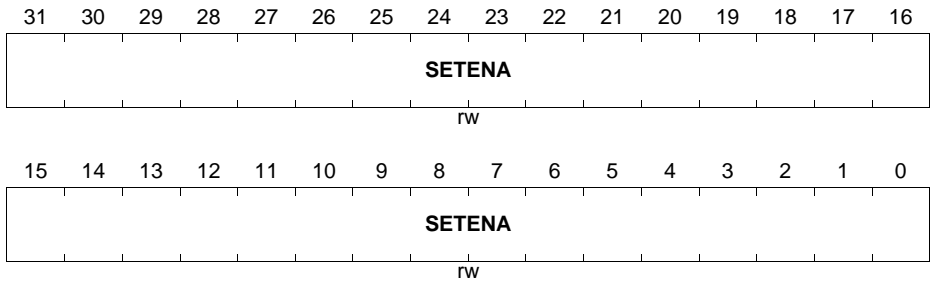
### 5.3.1 NVIC Registers

#### NVIC\_ISER

The ISER register enables interrupt nodes, and shows which interrupt nodes are enabled.

#### NVIC\_ISER

**Interrupt Set-enable Register (E000E100<sub>H</sub>)**      **Reset Value: 00000000<sub>H</sub>**



Field	Bits	Type	Description
SETENA	[31:0]	rw	<b>Interrupt Node Set-enable</b> 0 <sub>B</sub> Read: Interrupt node disabled. Write: No effect. 1 <sub>B</sub> Read: Interrupt node enabled. Write: Enable interrupt node

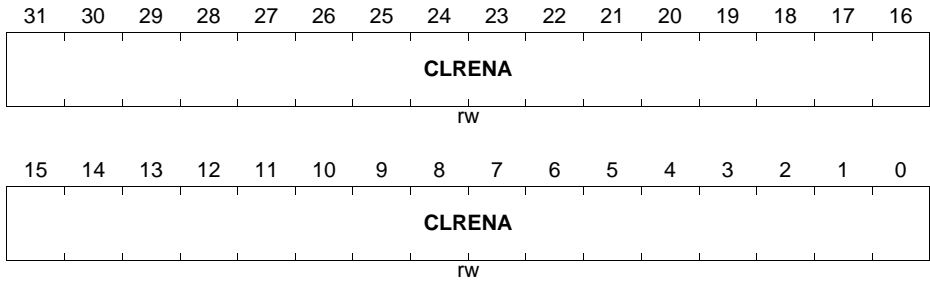
If a pending interrupt is enabled, the NVIC activates the interrupt based on its priority. If an interrupt is not enabled, asserting its interrupt signal changes the interrupt state to pending, but the NVIC never activates the interrupt, regardless of its priority.

**NVIC\_ICER**

The ICER register disables interrupt nodes, and shows which interrupt nodes are enabled.

**NVIC\_ICER**

**Interrupt Clear-enable Register (E000E180<sub>H</sub>)**      **Reset Value: 00000000<sub>H</sub>**



Field	Bits	Type	Description
<b>CLRENA</b>	[31:0]	rw	<b>Interrupt Node Clear-enable</b> 0 <sub>B</sub> Read: Interrupt node disabled. Write: No effect 1 <sub>B</sub> Read: Interrupt node enabled. Write: Disable interrupt node.

**NVIC\_ISPR**

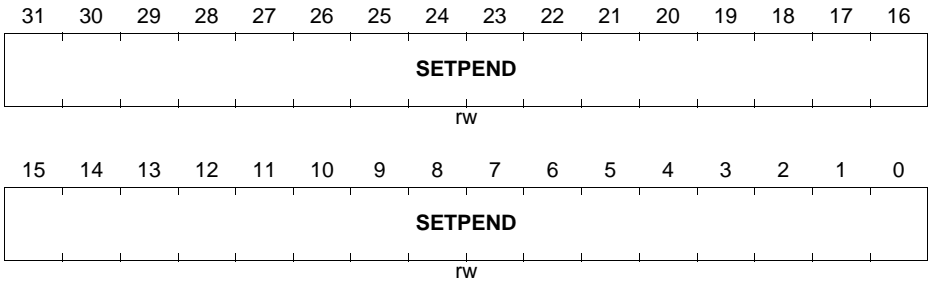
The ISPR register forces interrupt nodes into the pending state, and shows which interrupt nodes are pending.

**NVIC\_ISPR**

**Interrupt Set-pending Register**

(E000E200<sub>H</sub>)

Reset Value: 00000000<sub>H</sub>



Field	Bits	Type	Description
<b>SETPEND</b>	[31:0]	rw	<b>Interrupt Node Set-pending</b> 0 <sub>B</sub> Read: Interrupt node is not pending. Write: No effect 1 <sub>B</sub> Read: Interrupt node is pending. Write: Change interrupt state to pending.

*Note: Writing 1 to the ISPR bit corresponding to:*

- an interrupt node that is pending has no effect
- a disabled interrupt node sets the state of that interrupt node to pending

**NVIC\_ICPR**

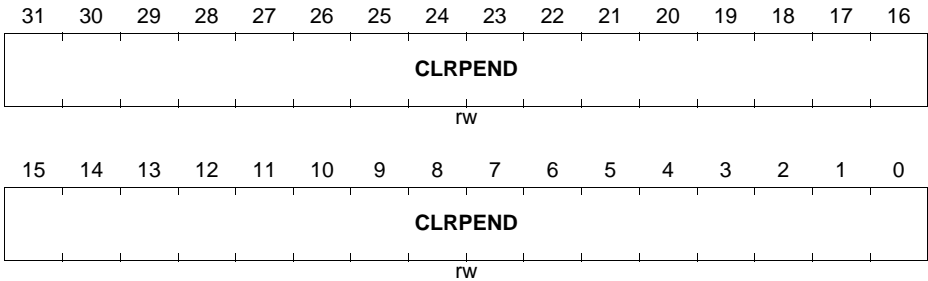
The ICPR register removes the pending state from interrupt nodes, and shows which interrupt nodes are pending.

**NVIC\_ICPR**

**Interrupt Clear-pending Register**

(E000E280<sub>H</sub>)

Reset Value: 00000000<sub>H</sub>



Field	Bits	Type	Description
<b>CLRPEND</b>	[31:0]	rw	<p><b>Interrupt Node Clear-pending</b></p> <p>0<sub>B</sub> Read: Interrupt node is not pending. Write: No effect.</p> <p>1<sub>B</sub> Read: Interrupt node is pending. Write: Remove interrupt state from pending.</p>

*Note: Writing 1 to an ICPR bit does not affect the active state of the corresponding interrupt node.*

**NVIC\_IPRx (x=0-7)**

The IPR0-IPR7 registers provide a 8-bit priority field for each interrupt node. Each register holds four priority fields.

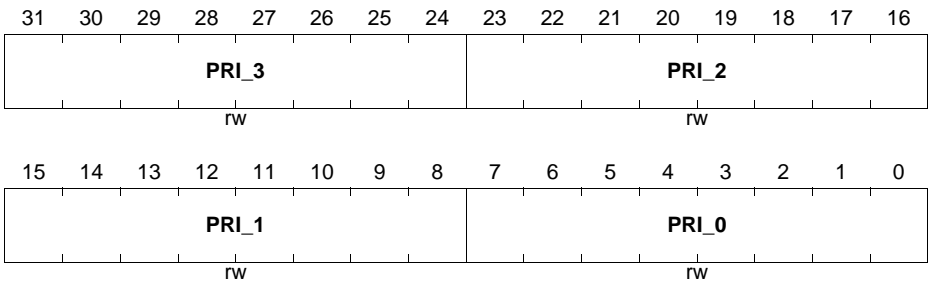
Each priority field holds a priority value, 0-192. The lower the value, the greater the priority of the corresponding interrupt node. The processor implements only bits [7:6] of each field, bits [5:0] reads as 0 and ignores writes. This means writing 255 to a priority register saves value 192 to the register.

**NVIC\_IPRx (x=0-7)**

**Interrupt Priority Register x**

**(E00E400<sub>H</sub> + 4\*x)**

**Reset Value: 00000000<sub>H</sub>**



Field	Bits	Type	Description
<b>PRI_3</b>	[31:24]	rw	<b>Priority, Byte Offset 3</b>
<b>PRI_2</b>	[23:16]	rw	<b>Priority, Byte Offset 2</b>
<b>PRI_1</b>	[15:8]	rw	<b>Priority, Byte Offset 1</b>
<b>PRI_0</b>	[7:0]	rw	<b>Priority, Byte Offset 0</b>

**5.4 Interrupt Request Source Overview**

An overview of all XMC1200 interrupt sources and related register bits are shown in the next few pages.

**Table 5-6 Interrupt Source Overview**

IRQ	Interrupt Node	Interrupt Source	Status Flag		Interrupt Enable		Set Flag		Clear Flag		Node Pointer	
			Register	Bit	Register	Bit	Register	Bit	Register	Bit	Register	Bit
0	SCU.SR0	Flash double bit ECC <sup>1)</sup>	SCU_SRRAW	FLECC2I	SCU_SRMASK	FLECC2I	SCU_SRSET	FLECC2I	SCU_SRCLR	SCU_SRCLR	FLECC2I	-
		NVM_NVM STATUS	NVM_NVM STATUS	ECC2REA D	-	-	-	-	NVM_NVM PROG	NVM_NVM PROG	RSTECC	-
		Flash operation complete	SCU_SRRAW	FLCMPLTI	NVM_NVMCONF	INT_ON	SCU_SRSET	FLCMPLTI	SCU_SRCLR	SCU_SRCLR	FLCMPLTI	-
		SRAM parity error	SCU_SRRAW	PESRAMI	SCU_SRMASK	PESRAMI	SCU_SRSET	PESRAMI	SCU_SRCLR	SCU_SRCLR	PESRAMI	-
		USIC RAM parity error	SCU_SRRAW	PEU0I	SCU_SRMASK	PEU0I	SCU_SRSET	PEU0I	SCU_SRCLR	SCU_SRCLR	PEU0I	-
		Loss of clock	SCU_SRRAW	LOCI	SCU_SRMASK	LOCI	SCU_SRSET	LOCI	SCU_SRCLR	SCU_SRCLR	LOCI	-



**Table 5-6 Interrupt Source Overview**

IRQ	Interrupt Node	Interrupt Source	Status Flag		Interrupt Enable		Set Flag		Clear Flag		Node Pointer	
			Register	Bit	Register	Bit	Register	Bit	Register	Bit	Register	Bit
1	SCU_SR1	Standby clock failure	SCU_SRRAW	SBYCLKFI	SCU_SRMASK	SBYCLKFI	SCU_SRSET	SCU_SRMASK	SBYCLKFI	SCU_SRCLR	SCU_SRMASK	SBYCLKFI
		VDDP pre-warning	SCU_SRRAW	VDDPI	SCU_SRMASK	VDDPI	SCU_SRSET	SCU_SRMASK	VDDPI	SCU_SRCLR	SCU_SRMASK	VDDPI
		VDDC drops below VDROF	SCU_SRRAW	VDROPI	SCU_SRMASK	VDROPI	SCU_SRSET	SCU_SRMASK	VDROPI	SCU_SRCLR	SCU_SRMASK	VDROPI
		VDDC rises above VCLIP	SCU_SRRAW	VCLIP	SCU_SRMASK	VCLIP	SCU_SRSET	SCU_SRMASK	VCLIP	SCU_SRCLR	SCU_SRMASK	VCLIP
		TSE done	SCU_SRRAW	TSE_DONE	SCU_SRMASK	TSE_DONE	SCU_SRSET	SCU_SRMASK	TSE_DONE	SCU_SRCLR	SCU_SRMASK	TSE_DONE
		TSE compare high	SCU_SRRAW	TSE_HIGH	SCU_SRMASK	TSE_HIGH	SCU_SRSET	SCU_SRMASK	TSE_HIGH	SCU_SRCLR	SCU_SRMASK	TSE_HIGH
		TSE compare low	SCU_SRRAW	TSE_LOW	SCU_SRMASK	TSE_LOW	SCU_SRSET	SCU_SRMASK	TSE_LOW	SCU_SRCLR	SCU_SRMASK	TSE_LOW
		WDT pre-warning	SCU_SRRAW	PRWARN	SCU_SRMASK	PRWARN	SCU_SRSET	SCU_SRMASK	PRWARN	SCU_SRCLR	SCU_SRMASK	PRWARN
		RTC periodic event	SCU_SRRAW	PI	-	-	SCU_SRSET	SCU_SRMASK	PI	SCU_SRCLR	SCU_SRMASK	PI
		RTC alarm	SCU_SRRAW	AI	-	-	SCU_SRSET	SCU_SRMASK	AI	SCU_SRCLR	SCU_SRMASK	AI
		RTC CTR Mirror Register updated	SCU_SRRAW	RTC_CTR	SCU_SRMASK	RTC_CTR	SCU_SRSET	SCU_SRMASK	RTC_CTR	SCU_SRCLR	SCU_SRMASK	RTC_CTR
		RTC ATIM0 Mirror Register updated	SCU_SRRAW	RTC_ATIM0	SCU_SRMASK	RTC_ATIM0	SCU_SRSET	SCU_SRMASK	RTC_ATIM0	SCU_SRCLR	SCU_SRMASK	RTC_ATIM0
		RTC ATIM1 Mirror Register updated	SCU_SRRAW	RTC_ATIM1	SCU_SRMASK	RTC_ATIM1	SCU_SRSET	SCU_SRMASK	RTC_ATIM1	SCU_SRCLR	SCU_SRMASK	RTC_ATIM1
		RTC TIM0 Mirror Register updated	SCU_SRRAW	RTC_TIM0	SCU_SRMASK	RTC_TIM0	SCU_SRSET	SCU_SRMASK	RTC_TIM0	SCU_SRCLR	SCU_SRMASK	RTC_TIM0
		RTC TIM1 Mirror Register updated	SCU_SRRAW	RTC_TIM1	SCU_SRMASK	RTC_TIM1	SCU_SRSET	SCU_SRMASK	RTC_TIM1	SCU_SRCLR	SCU_SRMASK	RTC_TIM1

**Table 5-6 Interrupt Source Overview**

IRQ	Interrupt Node	Interrupt Source	Status Flag		Interrupt Enable		Set Flag		Clear Flag		Node Pointer	
			Register	Bit	Register	Bit	Register	Bit	Register	Bit	Register	Bit
2	SCU_S R2	Out of range comparator x event (x=0-7)	SCU_SRRAW	ORCxI	SCU_SRMASK	ORCxI	SCU_SRSET	ORCxI	SCU_SRCLR	ORCxI	-	-
		Analog comparator x event (x=0-2)	SCU_SRRAW	ACMPxI	SCU_SRMASK	ACMPxI	SCU_SRSET	ACMPxI	SCU_SRCLR	ACMPxI	-	-
3, 4, 5, 6	ERU0_S R[3:0]	ERU0_IOUTx (x=0-3)	See section on ERU0 for details.									
7, 8	Reserved											
9, 10, 11, 12, 13, 14	USIC0_S R[5:0]	USIC: Standard receive event	USIC0_PSR	RIF	USIC0_CCR	RIEN	-	-	USIC0_PSCR	CRIF	USIC0_INPR	RINP
		USIC: Receive start event	USIC0_PSR	RSIF	USIC0_CCR	RSIEN	-	-	USIC0_PSCR	CRSIF	USIC0_INPR	TBINP
		USIC: Alternate receive event	USIC0_PSR	AIF	USIC0_CCR	AIEN	-	-	USIC0_PSCR	CAIF	USIC0_INPR	AINP
		USIC: Transmit shift event	USIC0_PSR	TSIF	USIC0_CCR	TSIEN	-	-	USIC0_PSCR	CTSIF	USIC0_INPR	TSINP
		USIC: Transmit buffer event	USIC0_PSR	TBIF	USIC0_CCR	TBIEN	-	-	USIC0_PSCR	CTBIF	USIC0_INPR	TBINP
		USIC: Data lost event	USIC0_PSR	DLIF	USIC0_CCR	DLIEN	-	-	USIC0_PSCR	CDLIF	USIC0_INPR	PINP
		USIC: BRG event	USIC0_PSR	BRGIF	USIC0_CCR	BRGIEN	-	-	USIC0_PSCR	CBRGIF	USIC0_INPR	PINP

**Table 5-6 Interrupt Source Overview**

IRQ	Interrupt Node	Interrupt Source	Status Flag		Interrupt Enable		Set Flag		Clear Flag		Node Pointer	
			Register	Bit	Register	Bit	Register	Bit	Register	Bit	Register	Bit
9, 10, 11, 12, 13, 14	USIC0_S R[5:0]	USIC: Standard transmit buffer event	USIC0_TRBSR	STBI	USIC0_TBCTR	STBIEN	-	USIC0_TRBSR	CSTBI	USIC0_TBCTR	STBINP	
		USIC: Standard transmit buffer event	USIC0_TRBSR	STBT	USIC0_TBCTR	STBIEN	-	-	-	USIC0_TBCTR	STBINP	
	USIC: Transmit Buffer error event	USIC0_TRBSR	TBERI	USIC0_TBCTR	TBERIEN	-	USIC0_TRBSR	CTBERI	USIC0_TBCTR	ATBINP		
	USIC: Standard receive buffer event	USIC0_TRBSR	SRBI	USIC0_RBCTR	SRBIEN	-	USIC0_TRBSR	CSRBI	USIC0_RBCTR	SRBINP		
	USIC: Standard receive buffer event	USIC0_TRBSR	SRBT	USIC0_RBCTR	SRBIEN	-	-	-	USIC0_RBCTR	SRBINP		
	USIC: Alternate receive buffer event	USIC0_TRBSR	ARBI	USIC0_RBCTR	ARBIEN	-	USIC0_TRBSR	CARBI	USIC0_RBCTR	ARBINP		
	USIC: Receive buffer error event	USIC0_TRBSR	RBERI	USIC0_RBCTR	RBERIEN	-	USIC0_TRBSR	CRBERI	USIC0_RBCTR	ARBINP		
	ASC: Synchronisation break detected	USIC0_PSR	SBD	USIC0_PCR	SBDIEN	-	USIC0_PSCR	CSD	USIC0_INPR	PINP		
	ASC: Collision detected	USIC0_PSR	COL	USIC0_PCR	CDIEN	-	USIC0_PSCR	CCOL	USIC0_INPR	PINP		
	ASC: Receiver noise detected	USIC0_PSR	RNS	USIC0_PCR	RNIEN	-	USIC0_PSCR	CRNS	USIC0_INPR	PINP		
	ASC: Format error in stop bit 0	USIC0_PSR	FER0	USIC0_PCR	FEIEN	-	USIC0_PSCR	CFER0	USIC0_INPR	PINP		
	ASC: Format error in stop bit 1	USIC0_PSR	FERT	USIC0_PCR	FEIEN	-	USIC0_PSCR	CFER1	USIC0_INPR	PINP		
	ASC: Receive frame finished	USIC0_PSR	RFF	USIC0_PCR	FFIEN	-	USIC0_PSCR	CRFF	USIC0_INPR	PINP		
	ASC: Transmit frame finished	USIC0_PSR	TFF	USIC0_PCR	FFIEN	-	USIC0_PSCR	CTFF	USIC0_INPR	PINP		

**Table 5-6 Interrupt Source Overview**

IRQ	Interrupt Node	Interrupt Source	Status Flag		Interrupt Enable		Set Flag		Clear Flag		Node Pointer	
			Register	Bit	Register	Bit	Register	Bit	Register	Bit	Register	Bit
9, 10, 11, 12, 13, 14	USIC0_S R[5:0]	SSC: MSLSEV event detected	USIC0_PSR	MSLSEV	USIC0_PCR	MSLSIEN	-	USIC0_PSCR	CMSLSEV	USIC0_INPR	PINP	PINP
		SSC: Parity error detected	USIC0_PSR	PAERR	USIC0_PCR	PARIEN	-	USIC0_PSCR	CPAERR	USIC0_INPR	PINP	PINP
		SSC: DX2T event detected	USIC0_PSR	DX2TEV	USIC0_PCR	DX2TIEN	-	USIC0_PSCR	CDX2TEV	USIC0_INPR	PINP	PINP
		IIC: Wrong TDF code detected	USIC0_PSR	WTDF	USIC0_PCR	ERRIEN	-	USIC0_PSCR	CWTDF	USIC0_INPR	PINP	PINP
		IIC: Start condition received	USIC0_PSR	SCR	USIC0_PCR	SCRIEN	-	USIC0_PSCR	CSCR	USIC0_INPR	PINP	PINP
		IIC: Repeated start condition received	USIC0_PSR	RSCR	USIC0_PCR	RSCRIEN	-	USIC0_PSCR	CRSCR	USIC0_INPR	PINP	PINP
		IIC: Stop condition received	USIC0_PSR	PCR	USIC0_PCR	PCRIEN	-	USIC0_PSCR	CPCR	USIC0_INPR	PINP	PINP
		IIC: NACK received	USIC0_PSR	NACK	USIC0_PCR	NACKIEN	-	USIC0_PSCR	CNACK	USIC0_INPR	PINP	PINP
		IIC: Arbitration lost	USIC0_PSR	ARL	USIC0_PCR	ARLIEN	-	USIC0_PSCR	CARL	USIC0_INPR	PINP	PINP
		IIC: Slave read request	USIC0_PSR	SRR	USIC0_PCR	SRIEN	-	USIC0_PSCR	CSRR	USIC0_INPR	PINP	PINP
		IIC: Error detected	USIC0_PSR	ERR	USIC0_PCR	ERRIEN	-	USIC0_PSCR	CERR	USIC0_INPR	PINP	PINP
		IIC: ACK received	USIC0_PSR	ACK	USIC0_PCR	ACKIEN	-	USIC0_PSCR	CACK	USIC0_INPR	PINP	PINP
		IIS: DX2T event detected	USIC0_PSR	DX2TEV	USIC0_PCR	DX2TIEN	-	USIC0_PSCR	CDX2TEV	USIC0_INPR	PINP	PINP
		IIS: WA falling edge event	USIC0_PSR	WAFE	USIC0_PCR	WAFIEN	-	USIC0_PSCR	CWAFE	USIC0_INPR	PINP	PINP
IIS: WA rising edge event	USIC0_PSR	WARE	USIC0_PCR	WAREIEN	-	USIC0_PSCR	CWARE	USIC0_INPR	PINP	PINP		
IIS: WA generation end	USIC0_PSR	END	USIC0_PCR	ENDIEN	-	USIC0_PSCR	CEND	USIC0_INPR	PINP	PINP		

**Table 5-6 Interrupt Source Overview**

IRQ	Interrupt Node	Interrupt Source	Status Flag		Interrupt Enable		Set Flag		Clear Flag		Node Pointer	
			Register	Bit	Register	Bit	Register	Bit	Register	Bit	Register	Bit
15, 16	VADC0_C0SR[1:0]	Source Event 0	VADC0_G xSEFLAG	SEV0	VADC0_G xQINR0	ENSI	VADC0_G xSEFLAG	SEV0	VADC0_G xSEFCLR	SEV0	VADC0_G xSEVNP	SEV0NP
17	VADC0_GxSR[1:0]	Source Event 1	VADC0_G xSEFLAG	SEV1	VADC0_G xASMR	ENSI	VADC0_G xSEFLAG	SEV1	VADC0_G xSEFCLR	SEV1	VADC0_G xSEVNP	SEV1NP
18, 19, 20	VADC0_GxSR[1:0] (x=0-1)	Channel Event y (y=0-7)	VADC0_G xCEFLAG	CEVy	VADC0_G xCHCTRY	CHEVMODE	VADC0_G xCEFLAG	CEVy	VADC0_G xCEFCLR	CEVy	VADC0_G xCEVNP	CEVyINP
		Result Event y (y=0-7)	VADC0_G xREFLAG	REVy	VADC0_G xRCRY	SRGEN	VADC0_G xREFLAG	REVy	VADC0_G xREFCLR	REVy	VADC0_G xREVNP0	REVyNP
		Result Event y (y=8-15)	VADC0_G xREFLAG	REVy	VADC0_G xRCRY	SRGEN	VADC0_G xREFLAG	REVy	VADC0_G xREFCLR	REVy	VADC0_G xREVNP1	REVyNP
		Global Source Event	VADC0_G LOBEFLA <sub>G</sub>	SEVGLB	VADC0_B RSMR	ENSI	VADC0_G LOBEFLA <sub>G</sub>	SEVGLB	VADC0_G LOBEFLA <sub>G</sub>	SEVGLBC LR	VADC0_G LOBEVNP	REV0NP
		Global Result Event	VADC0_G LOBEFLA <sub>G</sub>	REVGLB	VADC0_G LOBERCR	SRGEN	VADC0_G LOBEFLA <sub>G</sub>	REVGLB	VADC0_G LOBEFLA <sub>G</sub>	REVGLBC LR	VADC0_G LOBEVNP	SEV0NP

**Table 5-6 Interrupt Source Overview**

IRQ	Interrupt Node	Interrupt Source	Status Flag		Interrupt Enable		Set Flag		Clear Flag		Node Pointer	
			Register	Bit	Register	Bit	Register	Bit	Register	Bit	Register	Bit
21, 22, 23, 24	CCU40_SR[3:0]	Event 0 edge(s) information from event selector	CCU40_CC4yINTS	E0AS	CCU40_CC4yINTE	E0AE	CCU40_CC4ySWS	SE0A	CCU40_CC4ySWR	RE0A	CCU40_CC4ySRS	E0SR
		Event 1 edge(s) information from event selector	CCU40_CC4yINTS	E1AS	CCU40_CC4yINTE	E1AE	CCU40_CC4ySWS	SE1A	CCU40_CC4ySWR	RE1A	CCU40_CC4ySRS	E1SR
		Event 2 edge(s) information from event selector	CCU40_CC4yINTS	E2AS	CCU40_CC4yINTE	E2AE	CCU40_CC4ySWS	SE2A	CCU40_CC4ySWR	RE2A	CCU40_CC4ySRS	E2SR
		Period Match while counting up	CCU40_CC4yINTS	PMUS	CCU40_CC4yINTE	PME	CCU40_CC4ySWS	SPM	CCU40_CC4ySWR	RPM	CCU40_CC4ySRS	POSR
		Compare Match while counting up	CCU40_CC4yINTS	CMUS	CCU40_CC4yINTE	CMUE	CCU40_CC4ySWS	SCMU	CCU40_CC4ySWR	RCMU	CCU40_CC4ySRS	CMSR
		Compare Match while counting down	CCU40_CC4yINTS	CMDS	CCU40_CC4yINTE	CMDE	CCU40_CC4ySWS	SCMD	CCU40_CC4ySWR	RCMD	CCU40_CC4ySRS	CMRS
		One Match while counting down	CCU40_CC4yINTS	OMDS	CCU40_CC4yINTE	OME	CCU40_CC4ySWS	SOM	CCU40_CC4ySWR	ROM	CCU40_CC4ySRS	POSR
		Entering Trap State	CCU40_CC4yINTS	TRPF	CCU40_CC4yINTE	E2AE	CCU40_CC4ySWS	STRPF	CCU40_CC4ySWR	RTRPF	CCU40_CC4ySRS	E2SR
25, 26, 27, 28	Reserved											
29	LEDTS0_SRO	Start of time slice	LEDTS0_EVFR	TSF	LEDTS0_GLOBCTL	ITS_EN	-	-	LEDTS0_EVFR	CTSF	-	-
		Start of extended time frame	LEDTS0_EVFR	TFF	LEDTS0_GLOBCTL	ITF_EN	-	-	LEDTS0_EVFR	CTFF	-	-
		Start of autoscan time period	LEDTS0_EVFR	TPF	LEDTS0_GLOBCTL	ITP_EN	-	-	LEDTS0_EVFR	CTPF	-	-

**Table 5-6 Interrupt Source Overview**

IRQ	Interrupt Node	Interrupt Source	Status Flag		Interrupt Enable		Set Flag		Clear Flag		Node Pointer	
			Register	Bit	Register	Bit	Register	Bit	Register	Bit	Register	Bit
30	LEDTS1_S01	Start of time slice	LEDTS1_EVFR	TSF	LEDTS1_GLOBCTL	ITS_EN	-	-	LEDTS1_EVFR	CTSF	-	-
		Start of extended time frame	LEDTS1_EVFR	TFF	LEDTS1_GLOBCTL	ITF_EN	-	-	LEDTS1_EVFR	CTFF	-	-
		Start of autoscan time period	LEDTS1_EVFR	TPF	LEDTS1_GLOBCTL	ITP_EN	-	-	LEDTS1_EVFR	CTPF	-	-
31	BCCU0_S00	Trigger 0	BCCU0_EVFR	T0F	BCCU0_EVIER	T0IEN	BCCU0_EVFSR	T0FS	BCCU0_EVFSR	T0FC	-	-
		Trigger 1	BCCU0_EVFR	T1F	BCCU0_EVIER	T1IEN	BCCU0_EVFSR	T1FS	BCCU0_EVFSR	T1FC	-	-
		FIFO Full	BCCU0_EVFR	FF	BCCU0_EVIER	FIEN	BCCU0_EVFSR	FFS	BCCU0_EVFSR	FFC	-	-
		FIFO Empty	BCCU0_EVFR	EF	BCCU0_EVIER	EIEN	BCCU0_EVFSR	EFS	BCCU0_EVFSR	EFC	-	-
		Trap	BCCU0_EVFR	TPF	BCCU0_EVIER	TPIEN	BCCU0_EVFSR	TPFS	BCCU0_EVFSR	TPFC	-	-

1) Flash ECC double bit error has two status flags, each having its own clear bit. It is sufficient to use only one of the status flag and ignore the other.

## 6 Event Request Unit (ERU)

As described in the Service Request Processing chapter, XMC1200 uses the Event Request Unit (ERU) to support the programmable interconnection for the processing of service requests.

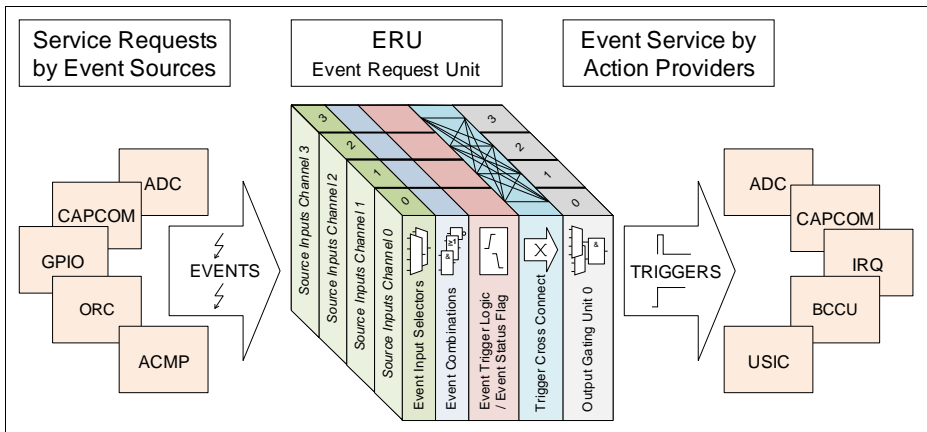
### 6.1 Features

The ERU supports these features:

- Flexible processing of external and internal service requests
- Programmable for edge and/or level triggering
- Multiple inputs per channel
- Triggers combinable from multiple inputs
- Input and output gating

### 6.2 Overview

The Event Request Unit (ERU) is a versatile multiple input event detection and processing unit.



**Figure 6-1 Event Request Unit Overview**

Each ERU unit consists of the following blocks:

- An **Event Request Select (ERS)** unit.
  - Event Input Selectors allow the selection of one out of two inputs. For each of these two inputs, an vector of 4 possible signals is available.
  - Event Combinations allow a logical combination of two input signals to a common trigger.



**Event Request Unit (ERU)**

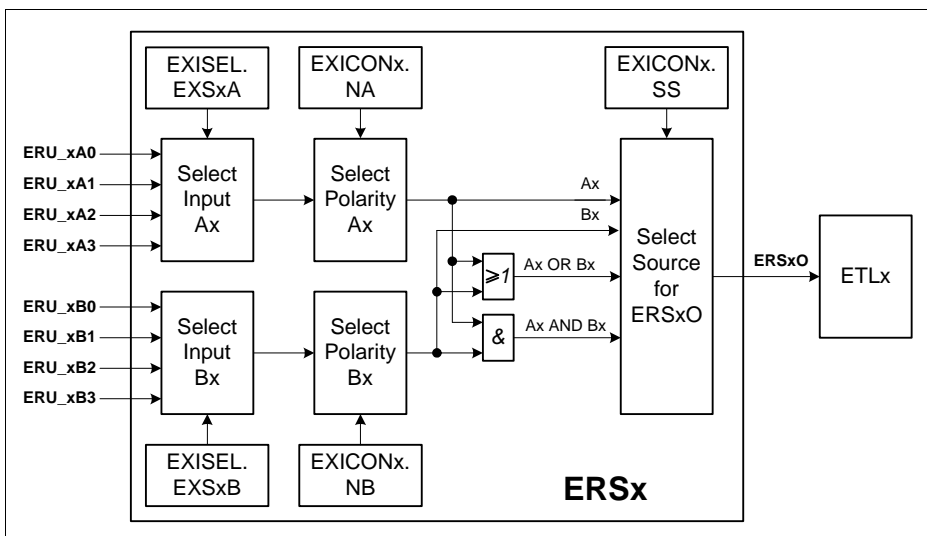
- An **Event Trigger Logic (ETL)** per Input Channel allows the definition of the transition (edge selection, or by software) that lead to a trigger event and can also store this status. Here, the input levels of the selected signals are translated into events.
- The Trigger **Cross Connect Matrix** distributes the events and status flags to the Output Channels. Additionally, trigger signals from other modules are made available and can be combined with the local triggers.
- An **Output Gating Unit (OGU)** combines the trigger events and status information and gates the Output depending on a gating signal.

*Note: An event of one Input can lead to reactions on several Outputs, or also events on several Inputs can be combined to a reaction on one Output.*

**6.3 Event Request Select Unit (ERS)**

For each Input Channel  $x$  ( $x = 0-3$ ), an ERS $x$  unit handles the input selection for the associated ETL $x$  unit. Each ERS $x$  performs a logical combination of two signals ( $A_x$ ,  $B_x$ ) to provide one combined output signal ERS $x$ O to the associated ETL $x$ . Input  $A_x$  can be selected from 4 options of the input vector ERU\_xA[3:0] and can be optionally inverted. A similar structure exists for input  $B_x$  (selection from ERU\_xB[3:0]).

In addition to the direct choice of either input  $A_x$  or  $B_x$  or their inverted values, the possible logical combinations for two selected inputs are a logical AND or a logical OR.



**Figure 6-2 Event Request Select Unit Overview**

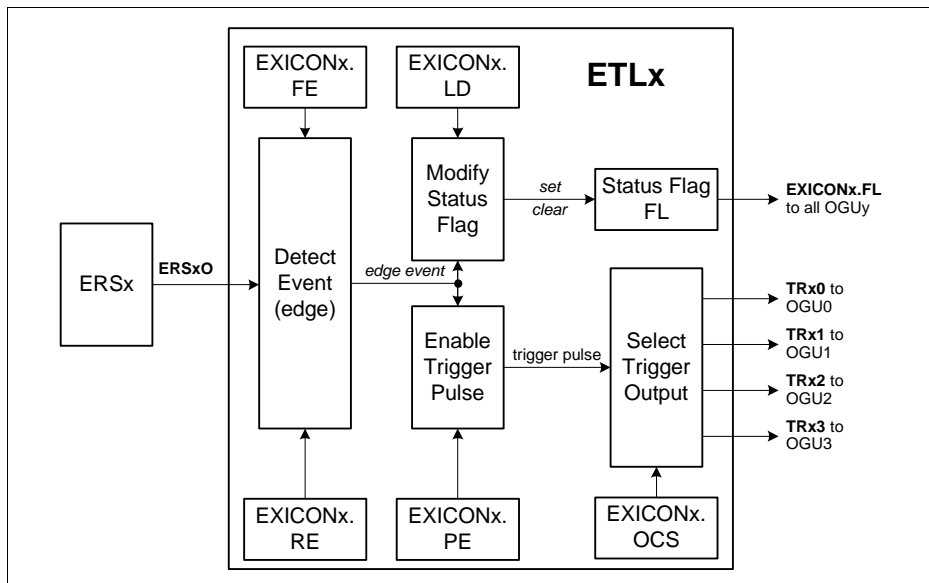
**Event Request Unit (ERU)**

The ERS units are controlled via register **ERU0\_EXISEL** (one register for all four ERSx units) and registers EXICONx (one register for each ERSx and associated ETLx unit, e.g. **ERU0\_EXICONx (x=0-3)** for Input Channel 0).

**6.4 Event Trigger Logic (ETLx)**

For each Input Channel x (x = 0-3), an event trigger logic ETLx derives a trigger event and related status information from the input ERSxO. Each ETLx is based on an edge detection block, where the detection of a rising or a falling edge can be individually enabled. Both edges lead to a trigger event if both enable bits are set (e.g. to handle a toggling input).

Each of the four ETLx units has an associated EXICONx register, that controls all options of an ETLx (the register also holds control bits for the associated ERSx unit, e.g. **ERU0\_EXICONx (x=0-3)** to control ERS0 and ETL0).



**Figure 6-3 Event Trigger Logic Overview**

When the selected event (edge) is detected, the status flag EXICONx.FL becomes set. This flag can also be modified by software. Two different operating modes are supported by this status flag.

It can be used as “sticky” flag, which is set by hardware when the desired event has been detected and has to be cleared by software. In this operating mode, it indicates that the event has taken place, but without indicating the actual status of the input.

## Event Request Unit (ERU)

In the second operating mode, it is cleared automatically if the “opposite” event is detected. For example, if only the falling edge detection is enabled to set the status flag, it is cleared when the rising edge is detected. In this mode, it can be used for pattern detection where the actual status of the input is important (enabling both edge detections is not useful in this mode).

The output of the status flag is connected to all following Output Gating Units (OGUy) in parallel (see [Figure 6-4](#)) to provide **pattern detection capability of all OGUy** units based on different or the same status flags.

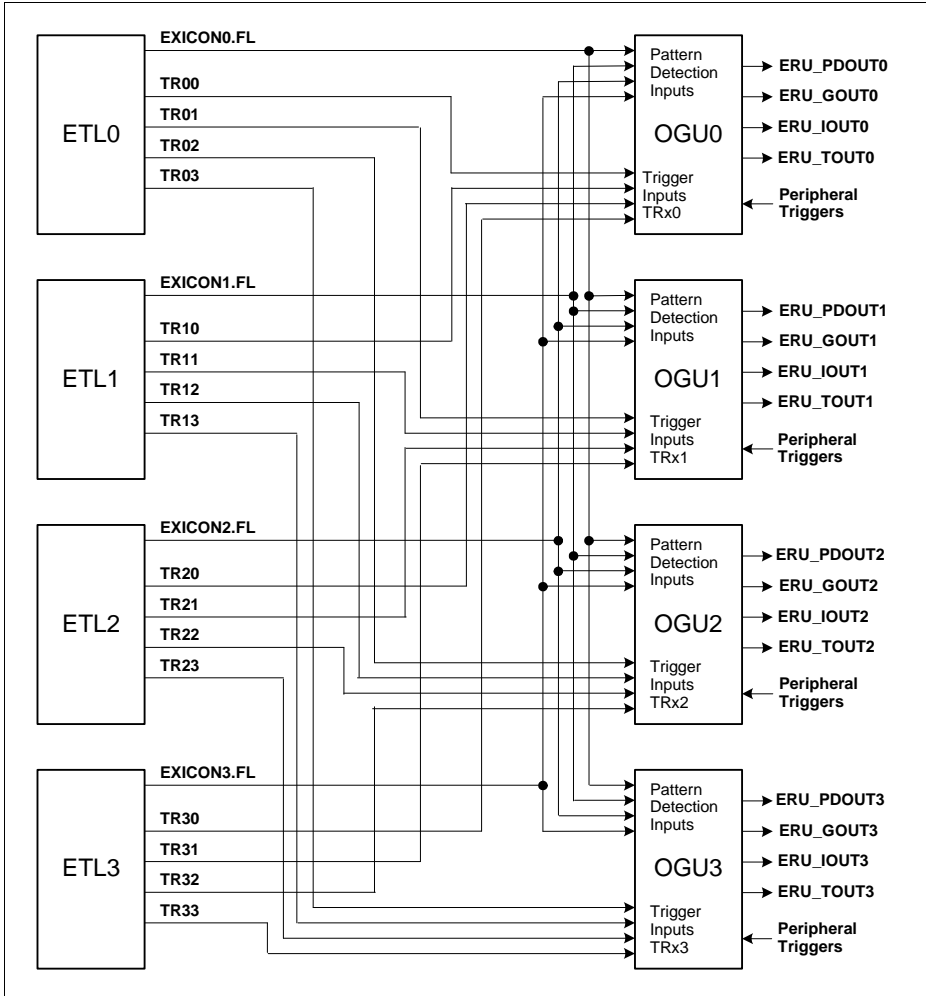
In addition to the modification of the status flag, a trigger pulse output TRxy of ETLx can be enabled (by bit EXICONx.PE) and selected to **trigger actions in one of the OGUy** units. The target OGUy for the trigger is selected by bit field EXICON.OCS.

The trigger becomes active when the selected edge event is detected, independently from the status flag EXICONx.FL.

### 6.5 Cross Connect Matrix

The matrix shown in [Figure 6-4](#) distributes the trigger signals (TRxy) and status signals (EXICONx.FL) from the different ETLx units between the OGUy units. In addition, it receives peripheral trigger signals that can be OR-combined with the ETLx trigger signals in the OGUy units.

**Event Request Unit (ERU)**



**Figure 6-4 ERU Cross Connect Matrix**

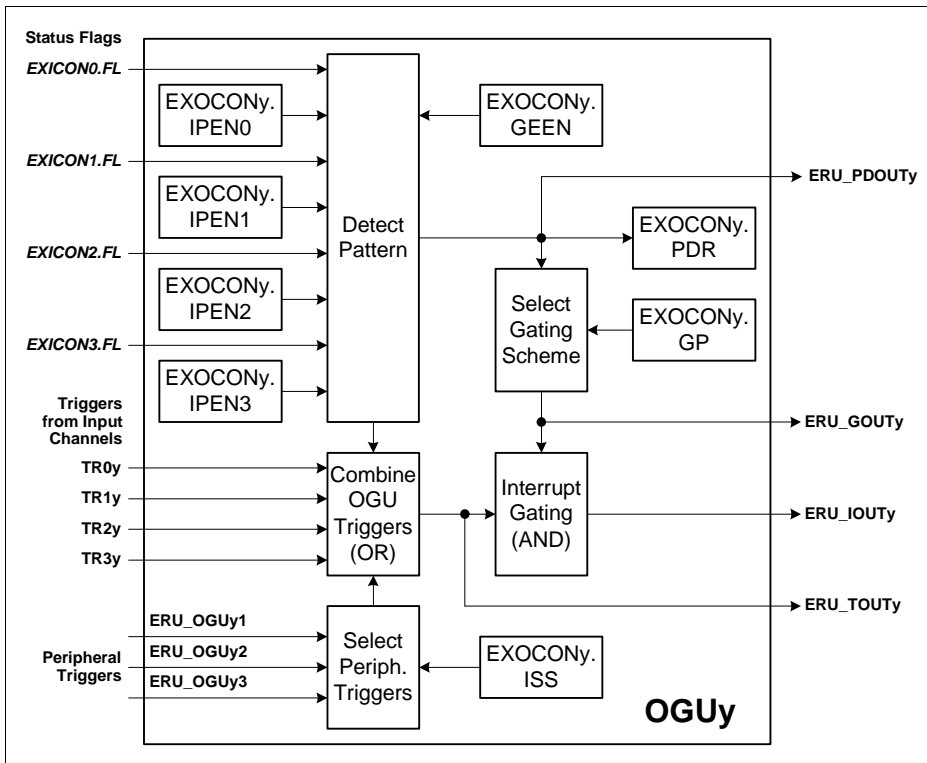
**6.6 Output Gating Unit (OGUy)**

Each OGUy (y = 0-3) unit combines the available trigger events and status flags from the Input Channels and distributes the results to the system. **Figure 6-5** illustrates the logic blocks within an OGUy unit. All functions of an OGUy unit are controlled by its associated

**Event Request Unit (ERU)**

EXOCONy register, e.g. **ERU0\_EXOCONx (x=0-3)** for OGU0. The function of an OGUy unit can be split into two parts:

- **Trigger Combination:**  
All trigger signals TRxy from the Input Channels that are enabled and directed to OGUy, a selected peripheral-related trigger event, and a pattern change event (if enabled) are logically OR-combined.
- **Pattern Detection:**  
The status flags EXICONx.FL of the Input Channels can be enabled to take part in the pattern detection. A pattern match is detected while all enabled status flags are set.



**Figure 6-5 Output Gating Unit for Output Channel y**

Each OGUy unit generates 4 output signals that are distributed to the system (not all of them are necessarily used):

- **ERU\_PDOUTy** to directly output the pattern match information for gating purposes in other modules (pattern match = 1).

## Event Request Unit (ERU)

- **ERU\_GOUTy** to output the pattern match or pattern miss information (inverted pattern match), or a permanent 0 or 1 under software control for gating purposes in other modules.
- **ERU\_TOUTy** as combination of a peripheral trigger, a pattern detection result change event, or the ETLx trigger outputs TRxy to trigger actions in other modules.
- **ERU\_IOUTy** as gated trigger output (ERU\_GOUTy logical AND-combined with ERU\_TOUTy) to trigger service requests (e.g. the service request generation can be gated to allow service request activation during a certain time window).

### Trigger Combination

The trigger combination logically OR-combines different trigger inputs to form a common trigger ERU\_TOUTy. Possible trigger inputs are:

- In each ETLx unit of the **Input Channels**, the trigger output TRxy can be enabled and the trigger event can be directed to one of the OGUy units.
- One out of three **peripheral trigger** signals per OGUy can be selected as additional trigger source. These peripheral triggers are generated by on-chip peripheral modules, such as capture/compare or timer units. The selection is done by bit field EXOCOny.ISS.
- In the case that at least one **pattern detection** input is enabled (EXOCOny.IPENx) and a change of the pattern detection result from pattern match to pattern miss (or vice-versa) is detected, a trigger event is generated to indicate a pattern detection result event (if enabled by ECOCONy.GEEN).

The trigger combination offers the possibility to program different trigger criteria for several input signals (independently for each Input Channel) or peripheral signals, and to combine their effects to a single output, e.g. to generate an service request or to start an ADC conversion. This combination capability allows the generation of a service request per OGU that can be triggered by several inputs (multitude of request sources results in one reaction).

The selection is defined by the bit fields ISS in registers **ERU0\_EXOCOnx (x=0-3)**.

### Pattern Detection

The pattern detection logic allows the combination of the status flags of all ETLx units. Each status flag can be individually included or excluded from the pattern detection for each OGUy, via control bits EXOCOny.IPENx. The pattern detection block outputs the following pattern detection results:

- **Pattern match** (EXOCOny.PDR = 1 and ERU\_PDOUTy = 1):  
A pattern match is indicated while all status flags FL that are included in the pattern detection are 1.
- **Pattern miss** (EXOCOny.PDR = 0 and ERU\_PDOUTy = 0):  
A pattern miss is indicated while at least one of the status flags FL that are included in the pattern detection is 0.

**Event Request Unit (ERU)**

In addition, the pattern detection can deliver a trigger event if the pattern detection result changes from match to miss or vice-versa (if enabled by EXOCONy.GEEN = 1). The pattern result change event is logically OR-combined with the other enabled trigger events to support service request generation or to trigger other module functions (e.g. in the ADC). The event is indicated when the pattern detection result changes and EXOCONy.PDR becomes updated.

The service request generation in the OGUy is based on the trigger ERU\_TOUTy that can be gated (masked) with the pattern detection result ERU\_PDOUTy. This allows an automatic and reproducible generation of service requests during a certain time window, where the request event is elaborated by the trigger combination block and the time window information (gating) is given by the pattern detection. For example, service requests can be issued on a regular time base (peripheral trigger input from capture/compare unit is selected) while a combination of input signals occurs (pattern detection based on ETLx status bits).

A programmable gating scheme introduces flexibility to adapt to application requirements and allows the generation of service requests ERU\_IOUTy under different conditions:

- **Pattern match** (EXOCONy.GP = 10<sub>B</sub>):  
A service request is issued when a trigger event occurs while the pattern detection shows a pattern match.
- **Pattern miss** (EXOCONy.GP = 11<sub>B</sub>):  
A service request is issued when the trigger event occurs while the pattern detection shows a pattern miss.
- **Independent** of pattern detection (EXOCONy.GP = 01<sub>B</sub>):  
In this mode, each occurring trigger event leads to a service request. The pattern detection output can be used independently from the trigger combination for gating purposes of other peripherals (independent use of ERU\_TOUTy and ERU\_PDOUTy with service requests on trigger events).
- **No service requests** (EXOCONy.GP = 00<sub>B</sub>, default setting)  
In this mode, an occurring trigger event does not lead to a service request. The pattern detection output can be used independently from the trigger combination for gating purposes of other peripherals (independent use of ERU\_TOUTy and ERU\_PDOUTy without service requests on trigger events).

## 6.7 Power, Reset and Clock

ERU is running on the main clock, MCLK. It is consuming power in all operating modes as long as the MCLK continues to run.

## **6.8 Initialization and System Dependencies**

Service Requests must always be enabled at the source and at the destination. Additionally it must be checked whether it is necessary to program the ERU0 process and route a request.

### **Enabling Peripheral SRx Outputs**

- Peripherals' SRx outputs must be selectively enabled. This procedure depends on the individual peripheral. Please look up the section "Service Request Generation" within a peripheral chapter for details.
- Optionally ERU0 must be programmed to process and route the request

### **Enabling External Requests**

- Selected PORTS must be programmed for input
- ERU0 must be programmed to process and route the external request

*Note: The number of external service request inputs may be limited by the package used.*



## 6.9 Registers

**Table 6-1 Registers Address Space**

Module	Base Address	End Address	Note
ERU0	4001 0600 <sub>H</sub>	4001 06FF <sub>H</sub>	

### Registers Overview

The absolute register address is calculated by adding:

Module Base Address + Offset Address

**Table 6-2 Register Overview**

Short Name	Description	Offset Address	Access Mode		Description See
			Read	Write	
EXISEL	ERU External Input Control Selection	0000 <sub>H</sub>	U, PV	U, PV	<a href="#">Page 6-11</a>
EXICON0	ERU External Input Control Selection	0010 <sub>H</sub>	U, PV	U, PV	<a href="#">Page 6-13</a>
EXICON1	ERU External Input Control Selection	0014 <sub>H</sub>	U, PV	U, PV	<a href="#">Page 6-13</a>
EXICON2	ERU External Input Control Selection	0018 <sub>H</sub>	U, PV	U, PV	<a href="#">Page 6-13</a>
EXICON3	ERU External Input Control Selection	001C <sub>H</sub>	U, PV	U, PV	<a href="#">Page 6-13</a>
EXOCON0	ERU Output Control Register	0020 <sub>H</sub>	U, PV	U, PV	<a href="#">Page 6-15</a>
EXOCON1	ERU Output Control Register	0024 <sub>H</sub>	U, PV	U, PV	<a href="#">Page 6-15</a>
EXOCON2	ERU Output Control Register	0028 <sub>H</sub>	U, PV	U, PV	<a href="#">Page 6-15</a>
EXOCON3	ERU Output Control Register	002C <sub>H</sub>	U, PV	U, PV	<a href="#">Page 6-15</a>

**Event Request Unit (ERU)**

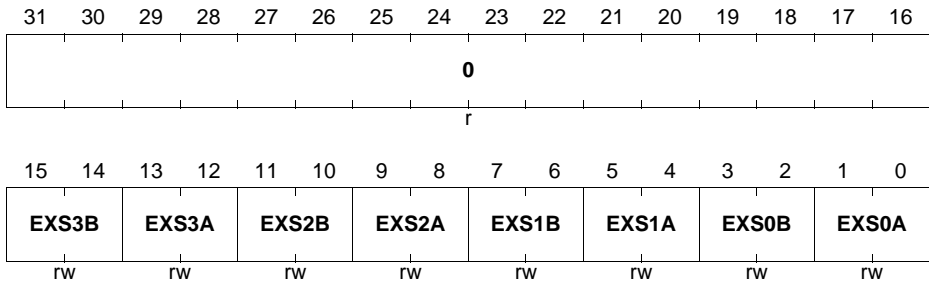
**6.9.1 ERU Registers**

**ERU0\_EXISEL**

**Event Input Select**

**(00<sub>H</sub>)**

**Reset Value: 0000 0000<sub>H</sub>**



Field	Bits	Type	Description
<b>EXS0A</b>	[1:0]	rw	<b>Event Source Select for A0 (ERS0)</b> This bit field defines which input is selected for A0. 00 <sub>B</sub> Input ERU_0A0 is selected 01 <sub>B</sub> Input ERU_0A1 is selected 10 <sub>B</sub> Input ERU_0A2 is selected 11 <sub>B</sub> Input ERU_0A3 is selected
<b>EXS0B</b>	[3:2]	rw	<b>Event Source Select for B0 (ERS0)</b> This bit field defines which input is selected for B0. 00 <sub>B</sub> Input ERU_0B0 is selected 01 <sub>B</sub> Input ERU_0B1 is selected 10 <sub>B</sub> Input ERU_0B2 is selected 11 <sub>B</sub> Input ERU_0B3 is selected
<b>EXS1A</b>	[5:4]	rw	<b>Event Source Select for A1 (ERS1)</b> This bit field defines which input is selected for A1. 00 <sub>B</sub> Input ERU_1A0 is selected 01 <sub>B</sub> Input ERU_1A1 is selected 10 <sub>B</sub> Input ERU_1A2 is selected 11 <sub>B</sub> Input ERU_1A3 is selected
<b>EXS1B</b>	[7:6]	rw	<b>Event Source Select for B1 (ERS1)</b> This bit field defines which input is selected for B1. 00 <sub>B</sub> Input ERU_1B0 is selected 01 <sub>B</sub> Input ERU_1B1 is selected 10 <sub>B</sub> Input ERU_1B2 is selected 11 <sub>B</sub> Input ERU_1B3 is selected

**Event Request Unit (ERU)**

Field	Bits	Type	Description
<b>EXS2A</b>	[9:8]	rw	<b>Event Source Select for A2 (ERS2)</b> This bit field defines which input is selected for A2. 00 <sub>B</sub> Input ERU_2A0 is selected 01 <sub>B</sub> Input ERU_2A1 is selected 10 <sub>B</sub> Input ERU_2A2 is selected 11 <sub>B</sub> Input ERU_2A3 is selected
<b>EXS2B</b>	[11:10]	rw	<b>Event Source Select for B2 (ERS2)</b> This bit field defines which input is selected for B2. 00 <sub>B</sub> Input ERU_2B0 is selected 01 <sub>B</sub> Input ERU_2B1 is selected 10 <sub>B</sub> Input ERU_2B2 is selected 11 <sub>B</sub> Input ERU_2B3 is selected
<b>EXS3A</b>	[13:12]	rw	<b>Event Source Select for A3 (ERS3)</b> This bit field defines which input is selected for A3. 00 <sub>B</sub> Input ERU_3A0 is selected 01 <sub>B</sub> Input ERU_3A1 is selected 10 <sub>B</sub> Input ERU_3A2 is selected 11 <sub>B</sub> Input ERU_3A3 is selected
<b>EXS3B</b>	[15:14]	rw	<b>Event Source Select for B3 (ERS3)</b> This bit field defines which input is selected for B3. 00 <sub>B</sub> Input ERU_3B0 is selected 01 <sub>B</sub> Input ERU_3B1 is selected 10 <sub>B</sub> Input ERU_3B2 is selected 11 <sub>B</sub> Input ERU_3B3 is selected
<b>0</b>	[31:16]	r	<b>Reserved</b> Read as 0; should be written with 0.

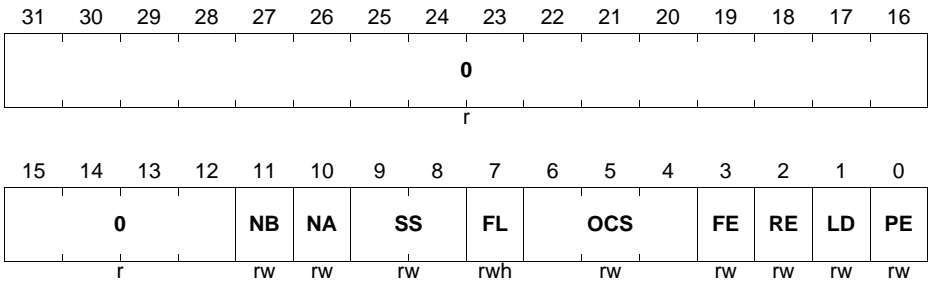
**Event Request Unit (ERU)**

**ERU0\_EXICONx (x=0-3)**

**Event Input Control x**

(10<sub>H</sub> + 4\*x)

Reset Value: 0000 0000<sub>H</sub>



Field	Bits	Type	Description
<b>PE</b>	0	rw	<p><b>Output Trigger Pulse Enable for ETLx</b></p> <p>This bit enables the generation of an output trigger pulse at TRxy when the selected edge is detected (set condition for the status flag FL).</p> <p>0<sub>B</sub> The trigger pulse generation is disabled 1<sub>B</sub> The trigger pulse generation is enabled</p>
<b>LD</b>	1	rw	<p><b>Rebuild Level Detection for Status Flag for ETLx</b></p> <p>This bit selects if the status flag FL is used as “sticky” bit or if it rebuilds the result of a level detection.</p> <p>0<sub>B</sub> The status flag FL is not cleared by hardware and is used as “sticky” bit. Once set, it is not influenced by any edge until it becomes cleared by software. 1<sub>B</sub> The status flag FL rebuilds a level detection of the desired event. It becomes automatically set with a rising edge if RE = 1 or with a falling edge if FE = 1. It becomes automatically cleared with a rising edge if RE = 0 or with a falling edge if FE = 0.</p>
<b>RE</b>	2	rw	<p><b>Rising Edge Detection Enable ETLx</b></p> <p>This bit enables/disables the rising edge event as edge event as set condition for the status flag FL or as possible trigger pulse for TRxy.</p> <p>0<sub>B</sub> A rising edge is not considered as edge event 1<sub>B</sub> A rising edge is considered as edge event</p>

**Event Request Unit (ERU)**

Field	Bits	Type	Description
<b>FE</b>	3	rw	<p><b>Falling Edge Detection Enable ETLx</b> This bit enables/disables the falling edge event as edge event as set condition for the status flag FL or as possible trigger pulse for TRxy.</p> <p>0<sub>B</sub> A falling edge is not considered as edge event 1<sub>B</sub> A falling edge is considered as edge event</p>
<b>OCS</b>	[6:4]	rw	<p><b>Output Channel Select for ETLx Output Trigger Pulse</b> This bit field defines which Output Channel OGUy is targeted by an enabled trigger pulse TRxy.</p> <p>000<sub>B</sub> Trigger pulses are sent to OGU0 001<sub>B</sub> Trigger pulses are sent to OGU1 010<sub>B</sub> Trigger pulses are sent to OGU2 011<sub>B</sub> Trigger pulses are sent to OGU3 Others: Reserved, do not use this combination</p>
<b>FL</b>	7	rwh	<p><b>Status Flag for ETLx</b> This bit represents the status flag that becomes set or cleared by the edge detection.</p> <p>0<sub>B</sub> The enabled edge event has not been detected 1<sub>B</sub> The enabled edge event has been detected</p>
<b>SS</b>	[9:8]	rw	<p><b>Input Source Select for ERSx</b> This bit field defines which logical combination is taken into account as ERSxO.</p> <p>00<sub>B</sub> Input A without additional combination 01<sub>B</sub> Input B without additional combination 10<sub>B</sub> Input A OR input B 11<sub>B</sub> Input A AND input B</p>
<b>NA</b>	10	rw	<p><b>Input A Negation Select for ERSx</b> This bit selects the polarity for the input A.</p> <p>0<sub>B</sub> Input A is used directly 1<sub>B</sub> Input A is inverted</p>
<b>NB</b>	11	rw	<p><b>Input B Negation Select for ERSx</b> This bit selects the polarity for the input B.</p> <p>0<sub>B</sub> Input B is used directly 1<sub>B</sub> Input B is inverted</p>
<b>0</b>	[31:12]	r	<p><b>Reserved</b> Read as 0; should be written with 0.</p>

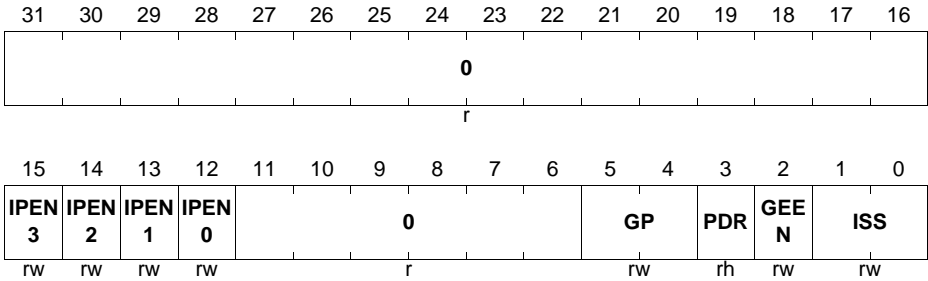
**Event Request Unit (ERU)**

**ERU0\_EXOCONx (x=0-3)**

**Event Output Trigger Control x**

( $20_H + 4*x$ )

**Reset Value: 0000 0008<sub>H</sub>**



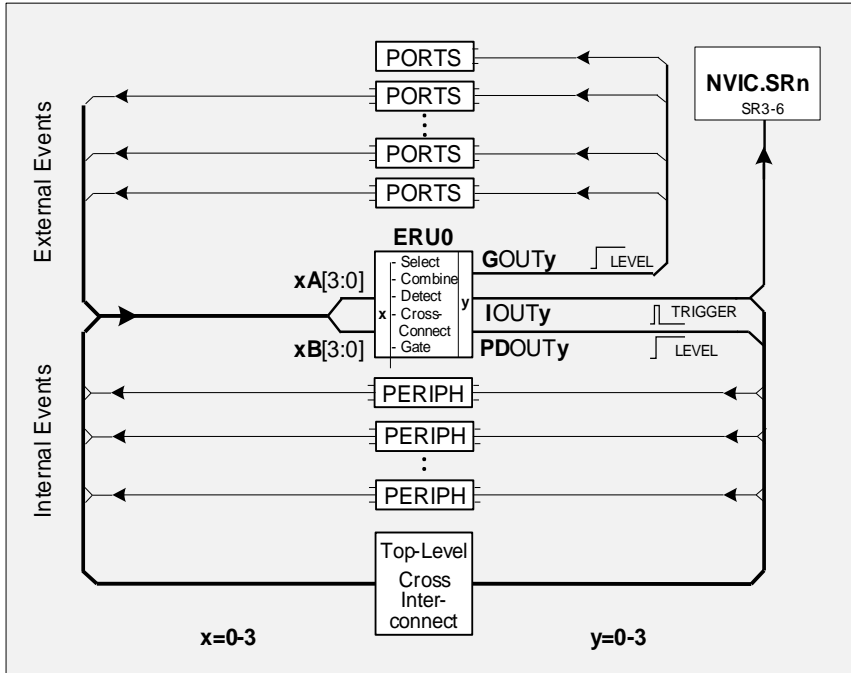
Field	Bits	Type	Description
<b>ISS</b>	[1:0]	rw	<b>Internal Trigger Source Selection</b> This bit field defines which input is selected as peripheral trigger input for OGUy. 00 <sub>B</sub> The peripheral trigger function is disabled 01 <sub>B</sub> Input ERU_OGUy1 is selected 10 <sub>B</sub> Input ERU_OGUy2 is selected 11 <sub>B</sub> Input ERU_OGUy3 is selected
<b>GEEN</b>	2	rw	<b>Gating Event Enable</b> Bit GEEN enables the generation of a trigger event when the result of the pattern detection changes from match to miss or vice-versa. 0 <sub>B</sub> The event detection is disabled 1 <sub>B</sub> The event detection is enabled
<b>PDR</b>	3	rh	<b>Pattern Detection Result Flag</b> This bit represents the pattern detection result. 0 <sub>B</sub> A pattern miss is detected 1 <sub>B</sub> A pattern match is detected

**Event Request Unit (ERU)**

Field	Bits	Type	Description
<b>GP</b>	[5:4]	rw	<p><b>Gating Selection for Pattern Detection Result</b> This bit field defines the gating scheme for the service request generation (relation between the OGU output ERU_PDOUTy and ERU_GOUTy).</p> <p>00<sub>B</sub> ERU_GOUTy is always disabled and ERU_IOUTy can not be activated</p> <p>01<sub>B</sub> ERU_GOUTy is always enabled and ERU_IOUTy becomes activated with each activation of ERU_TOUTy</p> <p>10<sub>B</sub> ERU_GOUTy is equal to ERU_PDOUTy and ERU_IOUTy becomes activated with an activation of ERU_TOUTy while the desired pattern is detected (pattern match PDR = 1)</p> <p>11<sub>B</sub> ERU_GOUTy is inverted to ERU_PDOUTy and ERU_IOUTy becomes activated with an activation of ERU_TOUTy while the desired pattern is not detected (pattern miss PDR = 0)</p>
<b>IPENx (x = 0-3)</b>	12+x	rw	<p><b>Pattern Detection Enable for ETLx</b> Bit IPENx defines whether the trigger event status flag EXICONx.FL of ETLx takes part in the pattern detection of OGUy.</p> <p>0<sub>B</sub> Flag EXICONx.FL is excluded from the pattern detection</p> <p>1<sub>B</sub> Flag EXICONx.FL is included in the pattern detection</p>
<b>0</b>	[31:16] , [11:6]	r	<p><b>Reserved</b> Read as 0; should be written with 0.</p>

## 6.10 Interconnects

This section describes how the ERU0 module is connected within the XMC1200 system.



**Figure 6-6 ERU Interconnects Overview**

### 6.10.1 ERU0 Connections

The following table shows the ERU0 connections.

**Table 6-3 ERU0 Pin Connections**

Global Inputs/Outputs	Connected To	I/O	Description
ERU0.0A0	ACMP0.OUT	I	
ERU0.0A1	P2.4	I	
ERU0.0A2	ORC2.OUT	I	
ERU0.0A3	VADC0.G0BFLOUT0	I	from ADC boundary flag
ERU0.0B0	P2.0	I	
ERU0.0B1	P2.2	I	



**Table 6-3 ERU0 Pin Connections**

<b>Global Inputs/Outputs</b>	<b>Connected To</b>	<b>I/O</b>	<b>Description</b>
ERU0.0B2	ORC0.OUT	I	
ERU0.0B3	VADC0.G1BFLOUT0	I	from ADC boundary flag
ERU0.1A0	ACMP1.OUT	I	
ERU0.1A1	P2.5	I	
ERU0.1A2	ORC3.OUT	I	
ERU0.1A3	VADC0.G0BFLOUT1	I	from ADC boundary flag
ERU0.1B0	P2.1	I	
ERU0.1B1	P2.3	I	
ERU0.1B2	ORC1.OUT	I	
ERU0.1B3	VADC0.G1BFLOUT1	I	from ADC boundary flag
ERU0.2A0	ACMP2.OUT	I	
ERU0.2A1	P2.6	I	
ERU0.2A2	ORC4.OUT	I	
ERU0.2A3	VADC0.G0BFLOUT2	I	from ADC boundary flag
ERU0.2B0	P2.10	I	
ERU0.2B1	P2.11	I	
ERU0.2B2	ORC2.OUT	I	
ERU0.2B3	VADC0.G1BFLOUT2	I	from ADC boundary flag
ERU0.3A0	ORC7.OUT	I	
ERU0.3A1	P2.7	I	
ERU0.3A2	ORC5.OUT	I	
ERU0.3A3	VADC0.G0BFLOUT3	I	from ADC boundary flag
ERU0.3B0	P2.9	I	
ERU0.3B1	P2.8	I	
ERU0.3B2	ORC6.OUT	I	
ERU0.3B3	VADC0.G1BFLOUT3	I	from ADC boundary flag
ERU0.0GU01	CCU40.SR0	I	
ERU0.0GU02	VADC0.C0SR2	I	
ERU0.0GU03	reserved	I	
ERU0.0GU11	CCU40.SR1	I	

**Event Request Unit (ERU)**

**Table 6-3 ERU0 Pin Connections**

<b>Global Inputs/Outputs</b>	<b>Connected To</b>	<b>I/O</b>	<b>Description</b>
ERU0.OGU12	VADC0.C0SR2	I	
ERU0.OGU13	reserved	I	
ERU0.OGU21	CCU40.SR2	I	
ERU0.OGU22	VADC0.C0SR3	I	
ERU0.OGU23	reserved	I	
ERU0.OGU31	CCU40.SR3	I	
ERU0.OGU32	VADC0.C0SR3	I	
ERU0.OGU33	reserved	I	
ERU0.PDOUT0	VADC0.BGREQGTO VADC0.G0REQGTO VADC0.G1REQGTO CCU40.IN1D CCU40.IN0J USIC0_CH1.HWIN0 P0.0 P2.11	O	
ERU0.GOUT0	P0.0 P2.11	O	
ERU0.TOUT0	not connected	O	
ERU0.IOUT0	NVIC.ERU0.SR0 SCU.RTC_extclk VADC0.BGREQTRM VADC0.G0REQTRM VADC0.G1REQTRM CCU40.CLKB CCU40.IN0K BCCU0.TRAPINE	O	
ERU0.PDOUT1	VADC0.BGREQGTP VADC0.G0REQGTP VADC0.G1REQGTP CCU40.IN0D CCU40.IN1J USIC0_CH1.HWIN2 P0.1 P2.10	O	

**Table 6-3 ERU0 Pin Connections**

<b>Global Inputs/Outputs</b>	<b>Connected To</b>	<b>I/O</b>	<b>Description</b>
ERU0.GOUT1	P0.1 P2.10	O	
ERU0.TOUT1	not connected	O	
ERU0.IOUT1	NVIC.ERU0.SR1 VADC0.BGREQTRN VADC0.G0REQTRN VADC0.G1REQTRN CCU40.CLKC CCU40.IN1K BCCU0.TRAPINF	O	
ERU0.PDOUT2	VADC0.BGREQGTK VADC0.G0REQGTK VADC0.G1REQGTK CCU40.IN3D CCU40.IN2J P0.2 P2.1	O	
ERU0.GOUT2	P0.2 P2.1	O	
ERU0.TOUT2	not connected	O	
ERU0.IOUT2	NVIC.ERU0.SR2 VADC0.BGREQTRG VADC0.G0REQTRG VADC0.G1REQTRG CCU40.IN2K BCCU0.TRAPING	O	
ERU0.PDOUT3	VADC0.BGREQGTL VADC0.G0REQGTL VADC0.G1REQGTL CCU40.IN3J CCU40.IN2D P0.3 P2.0	O	
ERU0.GOUT3	P0.3 P2.0	O	

**Table 6-3 ERU0 Pin Connections**

<b>Global Inputs/Outputs</b>	<b>Connected To</b>	<b>I/O</b>	<b>Description</b>
ERU0.TOUT3	not connected	O	
ERU0.IOUT3	NVIC.ERU0.SR3 VADC0.BGREQTRH VADC0.G0REQTRH VADC0.G1REQTRH CCU40.IN3K BCCU0.TRAPINH	O	

# **On-Chip Memories**

## **7 Memory Organization**

This chapter provides description of the system memory organization, memory accesses and memory protection strategy.

### **References**

[5] Cortex®-M0 User Guide, ARM DUI 0497A (ID112109)

### **7.1 Overview**

The Memory Map in XMC1200 is based on standard ARM Cortex-M0 system memory map.

#### **7.1.1 Features**

The Memory Map implements the following features:

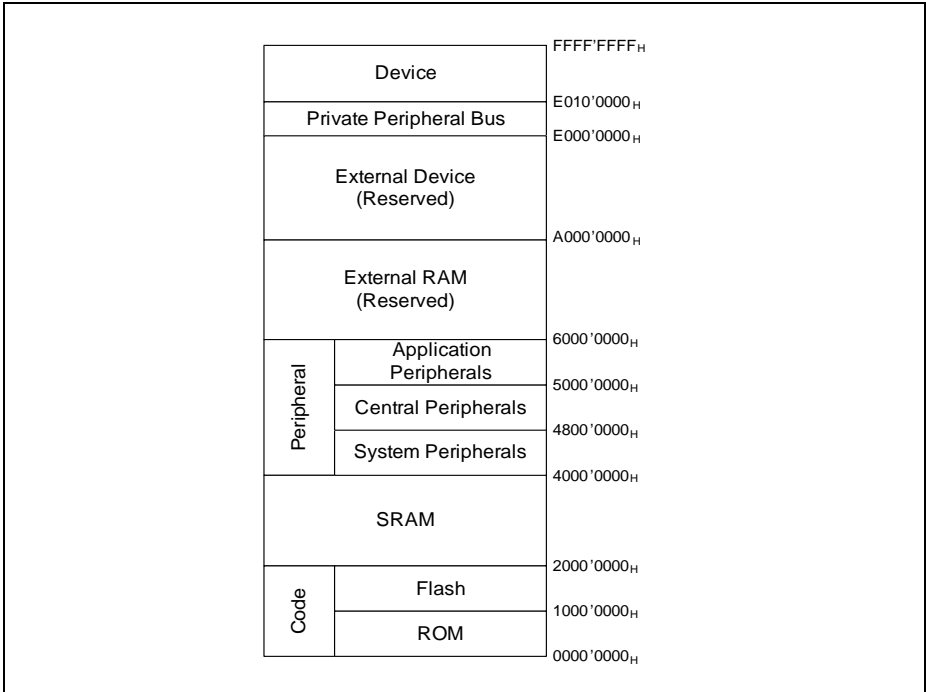
- Compatibility with standard ARM Cortex-M0 CPU [5]
- Full compatibility across entire XMC1000 Family

### **7.2 Memory Map**

**Table 7-1** defines detailed system memory map of XMC1200 where each individual peripheral or memory instance implement its own address spaces. For detailed register description of the system components and peripherals, please refer to respective chapters of this document.

*Note: Depending on the device variant, not all peripherals and memory address ranges may be available.*

**Memory Organization**



**Figure 7-1 XMC1200 Address Space**

**Memory Organization**

**Table 7-1 Memory Map**

Address space	Address Range	Description	Access Type <sup>1)</sup>	
			Read	Write
Code	00000000 <sub>H</sub> - 00000AFF <sub>H</sub>	ROM (user-readable)	U, PV	nBE
	00000B00 <sub>H</sub> - 00001FFF <sub>H</sub>	ROM (non-user-readable)	BE	BE
	00002000 <sub>H</sub> - 0FFFFFFF <sub>H</sub>	reserved	BE	BE
	10000000 <sub>H</sub> - 10000DFF <sub>H</sub>	Flash Sector 0 (non-user-readable)	nBE	nBE
	10000E00 <sub>H</sub> - 10000FFF <sub>H</sub>	Flash Sector 0 (user-readable)	U, PV	nBE
	10001000 <sub>H</sub> - 10032FFF <sub>H</sub>	Flash (200 Kbytes)	U, PV	U, PV
	10033000 <sub>H</sub> - 1FFFFFFF <sub>H</sub>	reserved	BE	BE
SRAM <sup>2)</sup>	20000000 <sub>H</sub> - 20000FFF <sub>H</sub>	SRAM Block 0	U, PV	U, PV
	20001000 <sub>H</sub> - 20001FFF <sub>H</sub>	SRAM Block 1	U, PV	U, PV
	20002000 <sub>H</sub> - 20002FFF <sub>H</sub>	SRAM Block 2	U, PV	U, PV
	20003000 <sub>H</sub> - 20003FFF <sub>H</sub>	SRAM Block 3	U, PV	U, PV
	20004000 <sub>H</sub> - 3FFFFFFF <sub>H</sub>	reserved	BE	BE



**Memory Organization**

**Table 7-1 Memory Map (cont'd)**

Address space	Address Range	Description	Access Type <sup>1)</sup>	
			Read	Write
System Peripherals	40000000 <sub>H</sub> - 400007FF <sub>H</sub>	Memory Control	U, PV	U, PV
	40000800 <sub>H</sub> - 4000FFFF <sub>H</sub>	reserved	BE	BE
	40010000 <sub>H</sub> - 40010FFF <sub>H</sub>	SCU (including RTC)	U, PV	U, PV
	40011000 <sub>H</sub> - 4001107F <sub>H</sub>	ANACTRL	U, PV	U, PV
	40011080 <sub>H</sub> - 4001FFFF <sub>H</sub>	reserved	BE	BE
	40020000 <sub>H</sub> - 4002001F <sub>H</sub>	WDT	U, PV	U, PV
	40020020 <sub>H</sub> - 4003FFFF <sub>H</sub>	reserved	BE	BE

**Memory Organization**

**Table 7-1 Memory Map (cont'd)**

Address space	Address Range	Description	Access Type <sup>1)</sup>	
			Read	Write
System Peripherals (cont'd)	40040000 <sub>H</sub> - 4004007F <sub>H</sub>	Port 0	U, PV	U, PV
	40040080 <sub>H</sub> - 400400FF <sub>H</sub>	reserved	BE	BE
	40040100 <sub>H</sub> - 4004017F <sub>H</sub>	Port 1	U, PV	U, PV
	40040180 <sub>H</sub> - 400401FF <sub>H</sub>	reserved	BE	BE
	40040200 <sub>H</sub> - 4004027F <sub>H</sub>	Port 2	U, PV	U, PV
	40040280 <sub>H</sub> - 4004FFFF <sub>H</sub>	reserved	BE	BE
	40050000 <sub>H</sub> - 400500DF <sub>H</sub>	Flash Registers	U, PV	U, PV
	400500E0 <sub>H</sub> - 47FFFFFF <sub>H</sub>	reserved	BE	BE
Central Peripherals	48000000 <sub>H</sub> - 480001FF <sub>H</sub>	USIC0 Channel 0	U, PV	U, PV
	48000200 <sub>H</sub> - 480003FF <sub>H</sub>	USIC0 Channel 1	U, PV	U, PV
	48000400 <sub>H</sub> - 480007FF <sub>H</sub>	USIC0 RAM	nBE	BE
	48000800 <sub>H</sub> - 4801FFFF <sub>H</sub>	reserved	BE	BE
	48020000 <sub>H</sub> - 480200FF <sub>H</sub>	PRNG	U, PV	U, PV
	48020010 <sub>H</sub> - 4802FFFF <sub>H</sub>	reserved	BE	BE

**Memory Organization**

**Table 7-1 Memory Map (cont'd)**

Address space	Address Range	Description	Access Type <sup>1)</sup>	
			Read	Write
Central Peripherals (cont'd)	48030000 <sub>H</sub> - 480303FF <sub>H</sub>	VADC0 General and Global Registers	U, PV	U, PV
	48030400 <sub>H</sub> - 480307FF <sub>H</sub>	VADC0 Group 0	U, PV	U, PV
	48030800 <sub>H</sub> - 48030BFF <sub>H</sub>	VADC0 Group 1	U, PV	U, PV
	48030C00 <sub>H</sub> - 48033FFF <sub>H</sub>	reserved	BE	BE
	48034000 <sub>H</sub> - 480341FF <sub>H</sub>	SHS0	U, PV	U, PV
	48034200 <sub>H</sub> - 4803FFFF <sub>H</sub>	reserved	BE	BE
	48040000 <sub>H</sub> - 480401FF <sub>H</sub>	CCU40 CC40 and Kernel Registers	U, PV	U, PV
	48040200 <sub>H</sub> - 480402FF <sub>H</sub>	CCU40 CC41	U, PV	U, PV
	48040300 <sub>H</sub> - 480403FF <sub>H</sub>	CCU40 CC42	U, PV	U, PV
	48040400 <sub>H</sub> - 480404FF <sub>H</sub>	CCU40 CC43	U, PV	U, PV
	48040500 <sub>H</sub> - 4FFFFFFF <sub>H</sub>	reserved	BE	BE

**Memory Organization**

**Table 7-1 Memory Map (cont'd)**

Address space	Address Range	Description	Access Type <sup>1)</sup>	
			Read	Write
Application Peripherals	50000000 <sub>H</sub> - 5001FFFF <sub>H</sub>	reserved	BE	BE
	50020000 <sub>H</sub> - 5002003F <sub>H</sub>	LEDTS0	U, PV	U, PV
	50020040 <sub>H</sub> - 500203FF <sub>H</sub>	reserved	BE	BE
	50020400 <sub>H</sub> - 5002043F <sub>H</sub>	LEDTS1	U, PV	U, PV
	50020440 <sub>H</sub> - 5002FFFF <sub>H</sub>	reserved	BE	BE
	50030000 <sub>H</sub> - 500301FF <sub>H</sub>	BCCU0	U, PV	U, PV
	50030200 <sub>H</sub> - 57FFFFFF <sub>H</sub>	reserved	BE	BE
Peripheral	58000000 <sub>H</sub> - 5FFFFFFF <sub>H</sub>	reserved	BE	BE
External SRAM	60000000 <sub>H</sub> - 9FFFFFFF <sub>H</sub>	reserved	BE	BE
External Device	A0000000 <sub>H</sub> - DFFFFFFF <sub>H</sub>	reserved	BE	BE
Private Peripheral Bus	E0000000 <sub>H</sub> - E0FFFFFF <sub>H</sub>	NVIC, System timer, System Control Block	U, PV	U, PV
Vendor specific 1	E0100000 <sub>H</sub> - EFFFFFFF <sub>H</sub>	reserved	BE	BE
Vendor specific 2	F0000000 <sub>H</sub> - F0000FFF <sub>H</sub>	System ROM Table	U, PV	nBE
	F0001000 <sub>H</sub> - FFFFFFF <sub>H</sub>	reserved	BE	BE

1) For address ranges taken up by peripherals, the access type for each address in the range may differ from that shown in the table. Refer to respective chapters for details.

2) The address range 2000'0000<sub>H</sub> to 2000'01FF<sub>H</sub> will be overwritten by start-up software during device start-up.

### 7.3 Memory Access

This section describes the memory accesses to the different type of memories in XMC1200.

#### 7.3.1 Flash Memory Access

The XMC1200 provides up to 200 Kbytes of Flash memory for instruction code or constant data, starting at address 1000'1000<sub>H</sub>. This excludes Flash sector 0, which is used to store system information and is always read only.

For details of Flash memory access, refer to the Flash Architecture chapter.

#### 7.3.2 SRAM Access

The XMC1200 provides 16 Kbytes of SRAM for instruction code or constant data, as well as system variables such as the system stack, starting at address 2000'0000<sub>H</sub>.

The SRAM supports 8-bit, 16-bit and 32-bit writes, and generates one parity bit for each 8 bits of written data. A read operation will check for parity errors on the 32-bit read data. Accesses to the SRAM require no wait states.

The 16 Kbytes of SRAM is logically divided into four blocks of 4 Kbytes each. Accesses to blocks 1, 2 and 3 can be disabled and enabled again during run-time with the peripheral privilege access scheme. See PAU chapter for details.

*Note: The address range 2000'0000<sub>H</sub> to 2000'01FF<sub>H</sub> will be overwritten by the start-up software during device start-up. Therefore, these addresses should not be targeted during the download of code/data by the bootstrap loader into the SRAM nor should they store critical data that are still needed by the application after a system reset or SW master reset.*

#### 7.3.3 ROM Access

The XMC1200 provides 8 Kbytes of ROM, which contains the startup software, vector table and user routines.

Read accesses to the ROM require no wait states.

### 7.4 Memory Protection Strategy

Two aspects of memory protection are considered:

1. Intellectual Property (IP) Protection
2. Memory Access Protection during Run-time

The memory protection measures available in XMC1200 are listed in [Table 7-2](#).

**Table 7-2 Memory Protection Measures**

Protection Aspects	Protection Measures	Protection Target
IP protection	Blocking of unauthorized external access	Flash memory contents
Memory access protection	Bit protection scheme	Specific system-critical registers/bit fields
	Peripheral privilege access control	Specific address ranges; each range can be controlled independently

### 7.4.1 Intellectual Property (IP) Protection

IP protection refers to the prevention against unauthorized read out of critical data and user IP from Flash memory.

#### 7.4.1.1 Blocking of Unauthorized External Access

In XMC1200, the Boot Mode Index (BMI) is used to control the boot options such that once the BMI is programmed to enter user mode (productive), it is not allowed to enter the other boot modes without an erase of the complete user Flash (including sector 0).

Therefore, boot options that load and execute external code, including unauthorized code that might read out the Flash memory contents, will be blocked and only user code originating from the Flash memory can be executed.

### 7.4.2 Memory Access Protection during Run-time

Memory access protection refers to the prevention against unintended write access on a memory address space during run-time.

#### 7.4.2.1 Bit Protection Scheme

The bit protection scheme prevents direct software writing of selected register bits (i.e., protected bits) using the PASSWD register in the SCU module. When the bit field MODE is  $11_B$ , writing  $10011_B$  to the bit field PASS opens access to writing of all protected bits, and writing  $10101_B$  to the bit field PASS closes access to writing of all protected bits. In both cases, the value of the bit field MODE is not changed even if PASSWD register is written with  $98_H$  or  $A8_H$ . It can only be changed when bit field PASS is written with  $11000_B$ , for example, writing  $0000'00C0_H$  to PASSWD register disables the bit protection scheme.

Access is opened for maximum 32 MCLKs if the “close access” password is not written. If “open access” password is written again before the end of 32 MCLK cycles, there will be a recount of 32 MCLK cycles.

Table 7-3 shows the list of protected bit in XMC1200.

**Table 7-3 List of Protected Register Bit Fields**

Register	Bit Field
SCU_CLKCR	FDIV, IDIV, PCLKSEL, RTCLKSEL
SCU_CGATSET0	All bits
SCU_CGATCLR0	All bits
SCU_ANAOFFSET	ADJL_OFFSET
VADC0_ACCPROT0	All bits
VADC0_ACCPROT1	All bits

Write to all protected registers except VADC0\_ACCPROT[1:0], without opening access through bit field PASS, will be ignored. No bus error will be generated. User should read back the register value to ensure the write has taken place.

Write to VADC0\_ACCPROT[1:0], without opening access through bit field PASS, will trigger a hard fault. If an interrupt occurs immediately after the access is opened and the interrupt service routine requires more than 32 MCLK cycles, the write to the register will happen after the access is closed and thereby, triggering a hard fault. To avoid this, interrupts should be disabled before writing to these two registers.

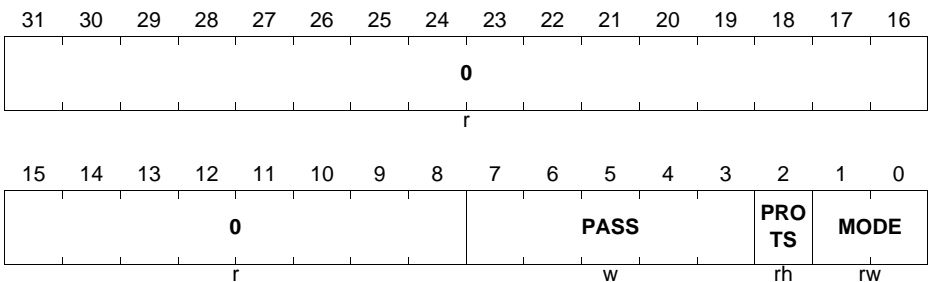
The PASSWD register is also described in the SCU chapter.

**SCU\_PASSWD**

**Password Register**

**(4001 0024<sub>H</sub>)**

**Reset Value: 0000 0007<sub>H</sub>**



Field	Bits	Type	Description
<b>MODE</b>	[1:0]	rw	<p><b>Bit Protection Scheme Control Bits</b></p> <p>00<sub>B</sub> Scheme disabled - direct access to the protected bits is allowed.</p> <p>11<sub>B</sub> Scheme enabled - the bit field PASS has to be written with the passwords to open and close the access to the protected bits. (Default)</p> <p>Others: Scheme enabled, similar to the setting for MODE = 11<sub>B</sub>.</p> <p>These two bits cannot be written directly. To change the value between 11<sub>B</sub> and 00<sub>B</sub>, the bit field PASS must be written with 11000<sub>B</sub>. Only then will the MODE bit field be registered.</p>
<b>PROTS</b>	2	rh	<p><b>Bit Protection Signal Status Bit</b></p> <p>This bit shows the status of the protection.</p> <p>0<sub>B</sub> Software is able to write to all protected bits.</p> <p>1<sub>B</sub> Software is unable to write to any of the protected bits.</p>
<b>PASS</b>	[7:3]	w	<p><b>Password Bits</b></p> <p>This bit protection scheme only recognizes the following three passwords:</p> <p>11000<sub>B</sub> Enables writing of the bit field MODE.</p> <p>10011<sub>B</sub> Opens access to writing of all protected bits.</p> <p>10101<sub>B</sub> Closes access to writing of all protected bits.</p>
<b>0</b>	[31:8]	r	<b>Reserved</b>

### 7.4.2.2 Peripheral Privilege Access Control

All CPU accesses are privileged accesses. In XMC1200, a separate scheme called Peripheral Privilege Access Control, which allows a peripheral's memory address space to be disabled to block any unintended write or read access, is provided. The address space can be re-enabled when necessary.

Refer to the PAU chapter for details.



## 8 Flash Architecture

This chapter describes the non volatile memory (NVM) module. The NVM has the following features:

- Reading by word, writing by block and erasing by page (256 bytes).
- Fast personalization support.
- Automatic verify support.
- Up to 50,000 erase cycles per page.
- Minimum data retention of 10 years at 25°C in cells that were never previously programmed.
- Flash programming voltage generated on-chip.
- Configurable erase and write protection.
- Power saving sleep mode.
- Incremental write without erase for semaphores.
- Redundancy sector for yield improvement.

### 8.1 Definitions

Throughout the document the terms NVM (Non Volatile Memory) and Flash are used as synonyms, disregarding the fact that NVM describes a broader class of memories, where the described Flash is only a special case.

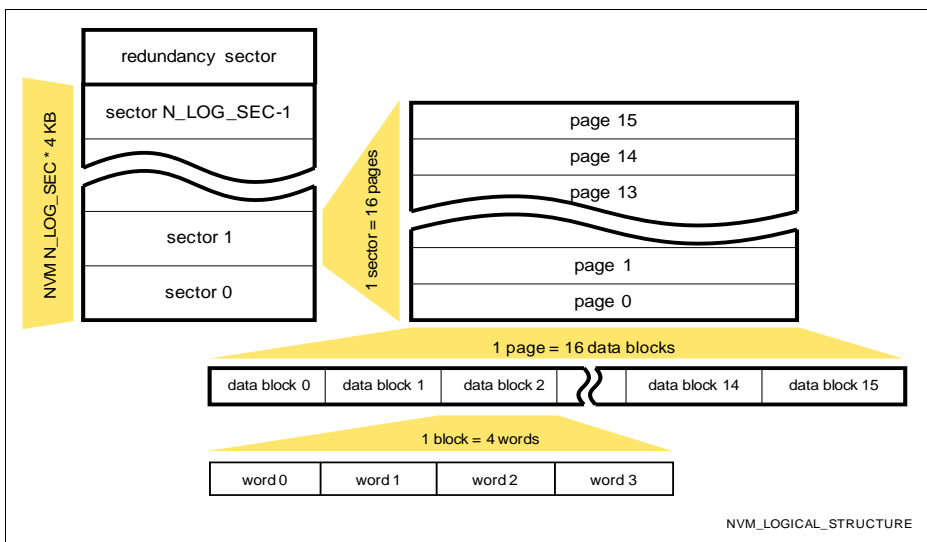


Figure 8-1 Logical structure of the NVM module

### 8.1.1 Logical and Physical States

#### Erasing

The erased state of a cell is '1'. Forcing an NVM cell to this state is called erasing. Erasing is possible with a granularity of a page (see below).

#### Writing

The written state of a cell is '0'. Changing an erased cell to this state is called writing. Writing is possible with a granularity of a block (see below).

#### Programming

The combination of erasing and writing is called programming. Programming often means also writing a previously erased page.

*Note: The termini **write** and **writing** are also used for accessing special function registers. The meaning depends therefore on the context.*

### 8.1.2 Data Portions

#### Word

A word consists of 32 bits. A word represents the data size which is read from or written to the NVM module within one access cycle.

#### Block

A block consists of 4 words (128 bit data, extended by 4 bit parity, and 6 bit ECC). A block represents the smallest data portion that can be written.

#### Page

A page consists of 16 blocks.

#### Sector

A sector consists of 16 pages.

### 8.1.3 Address Types

#### Physical Address

Address of the CPU system.

#### Base Address or Memory Base Address

Physical address of the lower boundary for memory accesses of an NVM module.

#### Logical Address

Memory address offset inside the NVM module: If the memory is addressed, the logical address is the physical address subtracted by the base address of the module.

#### Sector Address

Module specific part of the logical address specifying the sector, for calculation see [Section 8.2.1](#).

## Page Address

Module specific part of the logical address, for calculation see [Section 8.2.1](#).

### 8.1.4 Module Specific Definitions

The following table defines NVM specific constants used throughout this chapter.

**Table 8-1 Module Specific Definitions**

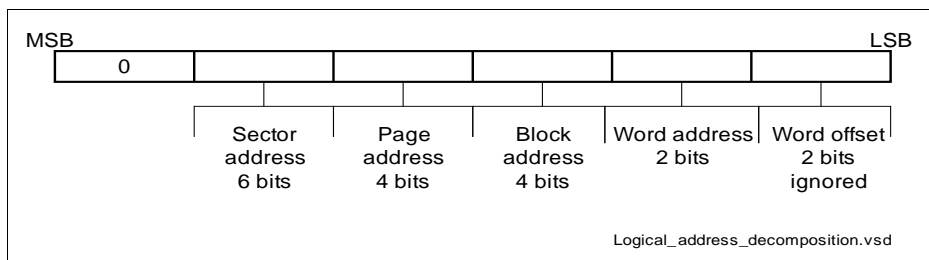
Module size [KB]	204	
Constant name	Value	Comment
N_BLOCKS	16	Number of blocks per page
N_PAGES	16	Number of pages per sector
N_SECTORS	52	Number of sectors including redundancy
N_LOG_SEC	51	Number of sectors excluding redundancy

## 8.2 Module Components

### 8.2.1 Memory Cell Array

The non-volatile memory cells are organized in sectors, which consist of pages, which on their part are structured in blocks.

A logical memory address *addr* has the following structure:



**Figure 8-2 Decomposition of Logical Address**

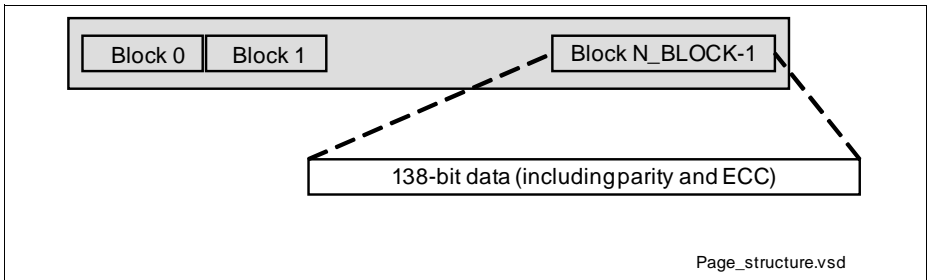
- *addr*[1:0] = word offset, for a memory address undefined and ignored
- *addr*[3:2] = word address
- *addr*[7:4] = block address
- *addr*[11:8] = page address
- *addr*[17:12] = sector address.

The memory subsystem always accesses whole words, therefore the word offset is ignored by the NVM module.

### 8.2.1.1 Page

Each page consists of 16 data blocks of 138 bits each (including parity bits and ECC bits).

A page is the granularity of data that can be erased in the cell array.



**Figure 8-3 Structure of a Page**

### 8.2.1.2 Sector

16 pages form a sector.

The whole cell array is build of 52 sectors.

## 8.3 Functional Description

The NVM module supports read and write accesses to the memory and to the special function registers (SFRs). No read-modify-write mechanism is supported for SFRs.

The main tasks of the NVM module are reading and writing from/to the memory array.

### 8.3.1 SFR Accesses

Reading the special function registers is possible in every mode of the NVM module.

Register write is not possible while the state machine is busy. The write is stalled in this case. For other exceptions see [Section 8.5.2](#).

### 8.3.2 Memory Read

The NVM memory can be read with a minimum granularity of a word provided that the word is in the memory address range of the module.

If the word is not within the memory address range of the NVM module, the module does not react at all and a different memory module may handle the access.

Memory read accesses are only possible while no FSM procedure (erase, write, verify, sleep or wake-up) is in progress. A memory read access while the FSM is busy is stalled until the FSM is idle again. Then the access is carried out. Such a stall will also stop the CPU from executing code.

The NVM will insert waitstates during memory read automatically if needed.

### 8.3.3 Memory Write

From the user's viewpoint data is written directly to the memory array. Module internally one block is buffered and the ECC bits are calculated. Then a finite state machine is started that writes the ECC and data bits to the memory field.

Writing does not support wrap-around, i.e. writing of a block has always to start with word 0 of the selected block and then automatically continues in ascending order up to word 3.

Since a block has to be written in four word writing steps, a special procedure has to be followed to transfer complete block data to the NVM: Writing of a block has always to start with word 0 of the addressed block. The following three writes need to address the other three words of the same block in ascending order. If this rule is not observed, the already provided words are discarded. If in this case the last provided word is addressing a word 0, this word is already accepted as the first word of a new block write procedure. Intermediate read operations do not influence the write data transfer. Intermediate read operations targeting the same address as the interrupted write operation are served from the memory array, i.e. do not read back the already transferred write data.

To write to the memory array, the NVM module has to be set to one-shot or continuous write mode by setting the SFR **NVMPROG** to the corresponding value. Data to be written

can now be written to the desired address. It is not checked, if the addressed block was erased before. Writing to a non erased block leads to corrupted data since writing can only clear bits but not set any bits. Reading such a block will lead most probably to an ECC fault.

A write access to the NVM when not in write mode does not trigger an exception or interrupt. The data is lost. Writes to the NVM are also used to trigger other operations which are described in the following subsections. Similarly, a write access to the NVM module has no effect and the data is lost when a protected sector is addressed (see [Section 8.3.6](#)).

Depending on the settings of **NVMPROG**, an automatic verify is performed (see [Section 8.3.5](#)).

In case of a one-shot write, write mode is automatically left. In case of continuous write mode, further write operations to new addresses can follow, until the write mode is explicitly left. Continuous write operations can target blocks within the complete memory without any restriction regarding sector or page borders.

### **8.3.4 Memory Erase**

Only whole pages can be physically erased, i.e. all bits of the addressed page are physically set to '1'.

To erase a page in the memory field, the NVM module has to be set to one-shot or continuous page erase mode by setting the SFR **NVMPROG** to the corresponding value. A write access to a memory location specifies the address of the page to be erased and triggers the erase.

A write access to the NVM when not in page erase mode does not trigger an exception or interrupt because they are also used to trigger other operations; as described in this section. Similarly, no erase is triggered when a protected sector is addressed (see [Section 8.3.6](#)).

In case of a one-shot page erase, page erase mode is automatically left. In case of continuous page erase mode, further page erase operations can follow, until the page erase mode is explicitly left.

### **8.3.5 Verify**

The data written as described in [Section 8.3.3](#) can be verified automatically. The written data in the cell array can be automatically compared to the data still available in the module internal buffer. This is automatically performed two times with hardread written and hardread erased. These hardread levels provide some margin compared to the normal read level to ensure that the data is really programmed with suitably distinct levels for written and erased bits. The verification result can be read at SFR **NVMSTATUS**.

Stand-alone verify operations can also be started by setting the SFR **NVMPROG** to the corresponding value. In this case, data written to a memory location is compared with the content of the memory field at the specified address. The comparison here is performed just once with a read level chosen before from normal read, hardread written and hardread erased.

A write access to the NVM when not in verification mode does not trigger an exception or interrupt because it is also used to trigger other operations; as described in this section. Similarly, a write access to the NVM module has no effect, when a protected sector is addressed (see **Section 8.3.6**).

In case of a one-shot verify, verify mode is automatically left. In case of continuous verify mode, further verify operations can follow, until the verify mode is explicitly left.

*Note: A continuous write operation without automatic verification, followed by two stand-alone verifications with 'hardread written' and 'hardread erased', is faster than a write operation with continuous automatic verification, since in the second case for every block write the hardread level has to be changed twice, whereas in the first case this change is performed only two times for the complete write data.*

*On the other hand, for the continuous automatic verification the reference data for the verification is directly available within the NVM module, whereas for the stand-alone verification the reference data needs to be provided again by the CPU.*

### **8.3.6 Erase-Protection and Write-Protection**

By setting **NVMCONF.SECPROT**, a configurable number of sectors can be selected to be protected from any modification, i.e. a range of sectors starting with sector 0 can be defined to be erase-protected and write-protected.

## **8.4 Redundancy**

To increase the production yield, the NVM module contains redundancy. Redundancy is transparent to the user.

## **8.5 Power Saving Modes**

The NVM module supports the following power saving modes. The modes differ in power consumption and in the time to restart the memory.

### **8.5.1 Idle Mode**

Idle mode is entered after reset after charging the pumps. In idle mode the power consumption is less than during a memory read access or write access.

Any operation of the NVM module (SFR access or memory access) can be started from idle mode without time delay.

### **8.5.2 Sleep Mode**

Entering and leaving NVM sleep mode requires special state machine sequences, which need some time. Therefore, besides SFR accesses, the NVM module cannot be used immediately after wake-up from sleep mode, as indicated by **NVMSTATUS.BUSY**.

NVM sleep mode is entered via WFE/WFI when Flash Power down is activated, see SCU chapter. Alternatively, sleep mode for the NVM module can be triggered by writing the respective bit in SFR **NVMCONF**.

In NVM sleep mode only the SFR **NVMCONF** can be read and written, all other SFRs can only be read. No memory access is possible in sleep mode.

### **8.6 Properties and Implementation of Error Correcting Code (ECC)**

The error correcting code (ECC) for the data blocks is a one-bit error correction and a (partial) double-bit error detection for every data block of 128 bit, which uses 4 parity bits and 6 ECC bits in addition to the protected 128 data bits. The correct ECC bits for every block are generated automatically when the data is written.



## 8.7 NVM SFRs

**Table 8-3** shows a complete list of the NVM special function registers.

**Table 8-2 Registers Address Space**

Module	Base Address	End Address	Note
NVM	4005 0000 <sub>H</sub>	4005 00FF <sub>H</sub>	

**Table 8-3 Registers Overview**

Register Short Name	Register Long Name	Offset Address	Page Number
<b>NVM SFRs, Register Descriptions</b>			
<b>NVMSTATUS</b>	NVM Status Register	0000 <sub>H</sub>	<a href="#">Page 8-10</a>
<b>NVMPROG</b>	NVM Programming Control Register	0004 <sub>H</sub>	<a href="#">Page 8-12</a>
<b>NVMCONF</b>	NVM Configuration Register	0008 <sub>H</sub>	<a href="#">Page 8-15</a>

The register is addressed wordwise.

Reading an SFR is not blocked, while the NVM module is busy. If the SFR value depends on the completion of an NVM sequence, **NVMSTATUS**.BUSY must be polled for 0<sub>B</sub>, before the SFR is read. Otherwise, reading the SFR might yield a value that is not updated yet.

## 8.7.1 Register Descriptions

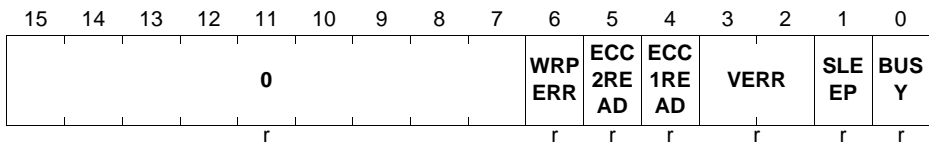
### NVM Status Register

#### NVMSTATUS

NVM Status Register

(0000<sub>H</sub>)

Reset Value: 0002<sub>H</sub>



Field	Bits	Type	Description
<b>0</b>	15:7	r	<b>Reserved</b> Read as 0.
<b>WRPERR</b>	6	r	<b>Write Protocol Error</b> The flag accumulates write protocol violations during the last 4-word write operations (for write or verify). It is also set when a triggered operation was ignored because of write protection. The correct protocol is defined in <a href="#">Section 8.3.3</a> . It is reset by hardware when <a href="#">NVMPROG.RSTECC</a> is written. 0 <sub>B</sub> <b>WRPROTOK</b> , No write protocol failure occurred. 1 <sub>B</sub> <b>WRPROTFAIL</b> , At least one write protocol failure was detected.
<b>ECC2READ</b>	5	r	<b>ECC2 Read<sup>1)</sup></b> The flag accumulates ECC two bit failure during memory read operations. It is reset by hardware when <a href="#">NVMPROG.RSTECC</a> is written. 0 <sub>B</sub> <b>ECC2RDOK</b> , No ECC two bit failure during memory read operations. 1 <sub>B</sub> <b>ECC2RDFAIL</b> , At least one ECC two bit failure was detected.

Field	Bits	Type	Description
<b>ECC1READ</b>	4	r	<p><b>ECC1 Read<sup>1)</sup></b> The flag accumulates ECC single bit failure during the last memory read operations. It is reset by hardware when <b>NVMPROG.RSTECC</b> is written.</p> <p>0<sub>B</sub> <b>ECC1RDOK</b>, No ECC single bit failure occurred. 1<sub>B</sub> <b>ECC1RDFAIL</b>, At least one ECC single bit failure was detected and corrected.</p>
<b>VERR</b>	3:2	r	<p><b>Verify Error</b> The flag is reset by hardware, when <b>NVMPROG.RSTVERR</b> is written. The flag is also reset, when write mode or verify-only mode are entered, i.e. <b>NVMPROG.ACTION.OPTYPE</b> = 0001<sub>B</sub> or <b>NVMPROG.ACTION.VERIFY</b> = 11<sub>B</sub>. The flag accumulates, i.e. <b>VERR</b> is updated every time a value higher than the current value is required, until write mode or verify-only mode are left (automatically in case of a one-shot write operation). Information on number of fail bits during verify procedure(s):</p> <p>00<sub>B</sub> <b>NOFAIL</b>, No fail bit. 01<sub>B</sub> <b>ONEFAIL</b>, One fail bit in one data block. 10<sub>B</sub> <b>TWOFAIL</b>, Two fail bits in two different data blocks. 11<sub>B</sub> <b>MOREFAIL</b>, Two or more fail bits in one data block, or three or more fail bits overall.</p>
<b>SLEEP</b>	1	r	<p><b>Sleep Mode</b> 0<sub>B</sub> <b>READY</b>, NVM not in sleep mode, and no sleep or wake up procedure in progress. 1<sub>B</sub> <b>SLEEP</b>, NVM in sleep mode, or busy due to a sleep or wake up procedure.</p>
<b>BUSY</b>	0	r	<p><b>Busy</b> 0<sub>B</sub> <b>READY</b>, The NVM is not busy. Memory reads from the cell array and register write accesses are possible. 1<sub>B</sub> <b>BUSY</b>, The NVM is busy. Memory reads and register write accesses are not possible.</p>

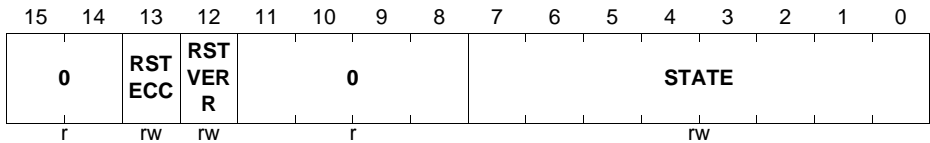
1) If a block is read from the field that contains two or more parity errors ECC1 and ECC2 errors may be flagged simultaneously.

**NVM Programming Control Register**

**NVMPROG**

**NVM Programming Control Register (0004<sub>H</sub>)**

**Reset Value: 0000<sub>H</sub>**



Field	Bits	Type	Description
<b>0</b>	15:1 4	r	<b>Reserved</b> Read as 0; should be written with 0.
<b>RSTECC</b>	13	rw	<b>Reset ECC</b> Can only be set by software, is reset automatically by hardware. 0 <sub>B</sub> <b>NOP</b> , No action. 1 <sub>B</sub> <b>RESET</b> , Reset of <b>NVMSTATUS.ECCxREAD</b> and <b>NVMSTATUS.WRPERR</b> .
<b>RSTVERR</b>	12	rw	<b>Reset Verify Error</b> Can only be set by software, is reset automatically by hardware. 0 <sub>B</sub> <b>NOP</b> , No action. 1 <sub>B</sub> <b>RESET</b> , Reset of <b>NVMSTATUS.VERR</b> .
<b>0</b>	11:8	r	<b>Reserved</b> Read as 0; should be written with 0.

Field	Bits	Type	Description
<b>ACTION</b>	7:0	rw	<p><b>ACTION: [VERIFY, ONE_SHOT, OPTYPE]</b></p> <p>This field selects an erase, write, or verify operation. See also <a href="#">More details on ACTION</a>. ACTION is a concatenation of three bit fields: ACTION[7:6] = VERIFY, ACTION[5:4] = ONE_SHOT and ACTION[3:0] = OPTYPE. <b>OPTYPE</b> defines the following operations:</p> <p>0000<sub>B</sub>: idle or verify-only, that depends on the setting of VERIFY;</p> <p>0001<sub>B</sub>: write;</p> <p>0010<sub>B</sub>: page erase.</p> <p><b>ONE_SHOT</b> is a parameter of OPTYPE with the following values:</p> <p>01<sub>B</sub>: once or</p> <p>10<sub>B</sub>: continuously.</p> <p>In case of 01<sub>B</sub>, ACTION is automatically reset to idle mode after operation has been performed.</p> <p><b>VERIFY</b> defines a second parameter of OPTYPE:</p> <p>01<sub>B</sub>: verification of written data with hardread levels after every write operation,</p> <p>10<sub>B</sub>: no verification, 11<sub>B</sub>: verification of array content.</p> <p>The following operations are defined, other values are interpreted as 00<sub>H</sub></p> <p>00<sub>H</sub> , Idle state, no action triggered. Writing 00<sub>H</sub> exits current mode.</p> <p>51<sub>H</sub> , Start one-shot write operation with automatic verify.</p> <p>91<sub>H</sub> , Start one-shot write operation without verify.</p> <p>61<sub>H</sub> , Start continuous write operation with automatic verify of every write.</p> <p>A1<sub>H</sub> , Start continuous write operation without verify.</p> <p>92<sub>H</sub> , Start one-shot page erase operation.</p> <p>A2<sub>H</sub> , Start continuous page erase operation.</p> <p>D0<sub>H</sub> , Start one-shot verify-only: Written data is compared to array content.</p> <p>E0<sub>H</sub> , Start continuous verify-only: Written data is compared to array content.</p>

### More details on ACTION

The operation selected by ACTION is performed, when a write to the NVM address range is performed, which defines the address (and block data) for the operation. Afterwards, in case of a one-shot operation, ACTION is automatically reset.

Verification results can be read at **NVMSTATUS.VERR**.

ACTION can only be changed when the current value of ACTION is 00<sub>H</sub>, otherwise ACTION is set to 00<sub>H</sub>. Once ACTION is not idle, ACTION can only be written again with its current value; any other value leads to a reset of ACTION.

Only write operations can be automatically verified. Page erase operations cannot use automatic verify, they must be started with ACTION.VERIFY = 10<sub>B</sub>.

If the correct erasing of a block or page is to be verified, a separate sequence using ACTION.VERIFY = 11<sub>B</sub> has to be started.

A verify operation requires the provision of the data for a complete block and always includes the ECC bits. The ECC bits for every block are generated automatically when the data is written.

A verify operation started with ACTION.VERIFY = 01<sub>B</sub> is automatically performed with both hardread written and hardread erased levels.

A verify operation started with ACTION.VERIFY = 11<sub>B</sub> is performed with the single hardread level defined by **NVMCONF.HRLEV** at this starting time.

A sequence started by setting ACTION will set **NVMSTATUS.BUSY** only after the transfer of the address (and block data) is performed. The end of the sequence can be detected either by polling NVMSTATUS.BUSY or by waiting for an NVM interrupt.

Entering sleep mode resets ACTION.

### NVM Configuration Register

NVMCONF is the only SFR that can be written while the module is in sleep mode. This is necessary to enable the use of NVM\_ON = 0<sub>B</sub> to go to sleep mode and of NVM\_ON = 1<sub>B</sub> to wake-up again.

#### NVMCONF

#### NVM Configuration Register

(0008<sub>H</sub>)

Reset Value: 9000<sub>H</sub>

15	14	13	12	11	10	9	8	7	6	5	4	3	2	1	0
<b>NVM_ON</b>	<b>INT_ON</b>	<b>0</b>	<b>1</b>	<b>SECPROT</b>								<b>0</b>	<b>HRELV</b>		<b>0</b>
rw	rw	rw	rw	rw								r	rw		rw

Field	Bits	Type	Description
<b>NVM_ON</b>	15	rw	<b>NVM On</b> When cleared, no software code can be executed anymore from the NVM, until it is set again. I.e., already the software code that initiates the change in NVM_ON itself may not reside in the NVM, otherwise the software is stalled forever. 0 <sub>B</sub> <b>SLEEP</b> , NVM is switched to or stays in sleep mode. 1 <sub>B</sub> <b>NORM</b> , NVM is switched to or stays in normal mode.
<b>INT_ON</b>	14	rw	<b>Interrupt On</b> When enabled the completion of a sequence started by setting <b>NVMPROG.ACTION</b> (write, erase or verify-only sequence) will be indicated by NVM interrupt. The same is true for the wake-up sequence. 0 <sub>B</sub> <b>INTOFF</b> , No NVM ready interrupts are generated. 1 <sub>B</sub> <b>INTON</b> , NVM ready interrupts are generated.
<b>0</b>	13	rw	<b>Reserved for Future Use</b> Must be written with 0 to allow correct operation.
<b>1</b>	12	rw	<b>Reserved for Future Use</b> Must be written with 1 to allow correct operation.
<b>SECPROT</b>	11:4	rw	<b>Sector Protection<sup>1)</sup></b> This field defines the number of write, erase, verify protected sectors, starting with physical sector 0.
<b>0</b>	3	r	<b>Reserved</b> Read as 0; should be written with 0.

Field	Bits	Type	Description
<b>HRLEV</b>	2:1	rw	<b>Hardread Level<sup>2)</sup></b> Defines single hardread level for verification with <b>NVMPROG.ACTION.VERIFY = 11<sub>B</sub></b> : 00 <sub>B</sub> <b>NR</b> , Normal read 01 <sub>B</sub> <b>HRW</b> , Hardread written 10 <sub>B</sub> <b>HRE</b> , Hardread erased 11 <sub>B</sub> <b>RFU</b> , Reserved for Future Use
<b>0</b>	0	rw	<b>Reserved for Future Use</b> Must be written with 0 to allow correct operation.

- 1) For SECPROT > 0, SECPROT defines the number of protected sectors. The sectors 0 to SECPROT-1 cannot be written, erased, or verified. All writes that target the protected sectors are accepted, but are internally ignored.
- 2) HRLEV defines the hardread level for a stand-alone verification sequence started with NVMPROG.ACTION.VERIFY = 11<sub>B</sub>. This hardread level is used until the end of the verification sequence. HRLEV may not be changed in between.



## 8.8 Example Sequences

This section presents some low-level programming examples.

In all following operations the protection defined by **NVMCONF**.SECPROT needs to be taken into account.

### 8.8.1 Writing to Memory

#### 8.8.1.1 Writing a Single Block

This sequence requires that the target block is already erased.

Additional assumption: **NVMPROG**.ACTION = 00<sub>H</sub>.

1. Start a one-shot write operation:  
Write **NVMPROG**.ACTION = 51<sub>H</sub> or 91<sub>H</sub>, respectively, if an automatic verification of the written data is to be performed or not.
2. Write data for one block to the physical address.
3. Poll flag **NVMSTATUS**.BUSY until write sequence has finished, or wait for NVMready interrupt (if enabled).
4. If an automatic verification of the written data was requested in the first step, read **NVMSTATUS**.VERR for the verification result.

If no verification of the written data was requested in step 1, and thus no read access to the NVM SFR is required in step 4, step 3 may be omitted.

The next access to the NVM module or the next write access to an NVM SFR (which ever comes first) will be automatically stalled, until the operation started in step 2 is finished.

#### 8.8.1.2 Writing Blocks

This sequence requires the target blocks are already erased.

Additional assumption: **NVMPROG**.ACTION = 00<sub>H</sub>.

1. Start a continuous write operation:  
Write **NVMPROG**.ACTION = 61<sub>H</sub> or A1<sub>H</sub>, respectively, if an automatic verification of the written data is to be performed or not.
2. Write data for one block to the physical address.
3. Poll flag **NVMSTATUS**.BUSY until write sequence has finished, or wait for NVMready interrupt (if enabled).  
Optionally, step 3 may be omitted: The next access to the NVM module or the next write access to an NVM SFR (which ever comes first) will be automatically stalled, until the operation started in step 2 is finished.
4. Jump to step 2 unless all data is written.

5. Stop continuous write operation:  
Write **NVMPROG**.ACTION = 00<sub>H</sub>.
6. If an automatic verification of the written data was requested in the first step, read **NVMSTATUS**.VERR for the verification result.

## 8.8.2 Erasing Memory

### 8.8.2.1 Erasing a Single Page

Assumption: **NVMPROG**.ACTION = 00<sub>H</sub>.

1. Start a one-shot page erase operation:  
Write **NVMPROG**.ACTION = 92<sub>H</sub>.
2. Write dummy data for one word to one arbitrary physical address of the page to be erased.
3. Poll flag **NVMSTATUS**.BUSY until page erase sequence has finished, or wait for NVMready interrupt (if enabled).

Optionally, step 3 may be omitted: The next access to the NVM module or the next write access to an NVM SFR (which ever comes first) will be automatically stalled, until the operation started in step 2 is finished.

### 8.8.2.2 Erasing Pages

Assumption: **NVMPROG**.ACTION = 00<sub>H</sub>.

1. Start a continuous page erase operation:  
Write **NVMPROG**.ACTION = A2<sub>H</sub>.
2. Write dummy data for one word to one arbitrary physical address of the page to be erased.
3. Poll flag **NVMSTATUS**.BUSY until page erase sequence has finished, or wait for NVMready interrupt (if enabled).

Optionally, step 3 may be omitted: The next access to the NVM module or the next write access to an NVM SFR (which ever comes first) will be automatically stalled, until the operation started in step 2 is finished.

4. Jump to step 2 unless all pages are erased.
5. Stop continuous page erase operation:  
Write **NVMPROG**.ACTION = 00<sub>H</sub>.

## 8.8.3 Verifying Memory

### 8.8.3.1 Verifying a Single Block

Assumption: **NVMPROG**.ACTION = 00<sub>H</sub>.

1. Choose desired hardread level by setting NVMCONF.HRLEV.
2. Start a one-shot verify operation:  
Write **NVMPROG**.ACTION = D0<sub>H</sub>.
3. Write reference data for one block to the physical address.
4. Poll flag **NVMSTATUS**.BUSY until verify sequence has finished, or wait for NVMready interrupt (if enabled).
5. Read **NVMSTATUS**.VERR for the verification result.

### 8.8.3.2 Verifying Blocks

Assumption: **NVMPROG**.ACTION = 00<sub>H</sub>.

1. Choose desired hardread level by setting NVMCONF.HRLEV.
2. Start a continuous verify operation:  
Write **NVMPROG**.ACTION = E0<sub>H</sub>.
3. Write reference data for one block to the physical address.
4. Poll flag **NVMSTATUS**.BUSY until verify sequence has finished, or wait for NVMready interrupt (if enabled).  
Optionally, step 4 may be omitted: The next access to the NVM module or the next write access to an NVM SFR (which ever comes first) will be automatically stalled, until the operation started in step 3 is finished.
5. Jump to step 3 unless all blocks are verified.
6. Stop continuous verify operation:  
Write **NVMPROG**.ACTION = 00<sub>H</sub>.
7. Read **NVMSTATUS**.VERR for the verification result.

### 8.8.4 Writing to an Already Written Block

Normally, writing additional bits in an already written block is not feasible, since the already written ECC bits and the parity bits would need an update, too, which in most cases would require to erase some bits, which is not possible. The result would be an ECC-faulty block.

For special purposes a repeated update of specially constructed data is possible, e.g. to store some marker bits for use in a power loss recovery SW implementation.

Starting with an erased block, and making use of the special structure of the ECC, it is possible to repeatedly add two newly written bits in identical bit positions to two arbitrary words of the block. This principle is shown in the exemplary writing scheme of [Table 8-4](#), where a block is updated 32 times without corruption of the ECC, i.e. the data stays ECC protected throughout the procedure.

**Table 8-4 Incremental Update of a Block with Specially Constructed Data**

<b>Operation</b>	<b>Block Write Data</b>	<b>Resulting Block Content<sup>1)</sup></b>
Erase block		FFFFFFFF FFFFFFFF FFFFFFFF FFFFFFFF
Add 1 <sup>st</sup> value	FFFFFFFF FFFFFFFC FFFFFFFF FFFFFFFFC	FFFFFFFF FFFFFFFC FFFFFFFF FFFFFFFFC
Add 2 <sup>nd</sup> value	FFFFFFFF FFFFFFF3 FFFFFFFF FFFFFFFF3	FFFFFFFF FFFFFFF0 FFFFFFFF FFFFFFFF0
Add 3 <sup>rd</sup> value	FFFFFFFF FFFFFFFCF FFFFFFFF FFFFFFFCF	FFFFFFFF FFFFFFFC0 FFFFFFFF FFFFFFFC0
Add 4 <sup>th</sup> value	FFFFFFFF FFFFFFF3F FFFFFFFF FFFFFFF3F	FFFFFFFF FFFFFF00 FFFFFFFF FFFFFFF00
Add 5 <sup>th</sup> value	FFFFFFFF FFFFFFFCF FFFFFFFF FFFFFFCF	FFFFFFFF FFFFFC00 FFFFFFFF FFFFFFC00
Add 6 <sup>th</sup> value	FFFFFFFF FFFFFFF3FF FFFFFFFF FFFFFFF3FF	FFFFFFFF FFFFF000 FFFFFFFF FFFFFF000
...	...	...
15 <sup>th</sup> value	FFFFFFFF CFFFFFFF FFFFFFFF CFFFFFFF	FFFFFFFF C0000000 FFFFFFFF C0000000
16 <sup>th</sup> value	FFFFFFFF 3FFFFFFF FFFFFFFF 3FFFFFFF	FFFFFFFF 00000000 FFFFFFFF 00000000
17 <sup>th</sup> value	FFFFFFFC FFFFFFFF FFFFFFFC FFFFFFF	FFFFFFFC 00000000 FFFFFFFC 00000000
...	...	...
30 <sup>th</sup> value	F3FFFFFF FFFFFFFF F3FFFFFF FFFFFFFF	F0000000 00000000 F0000000 00000000
31 <sup>st</sup> value	CFFFFFFF FFFFFFFF CFFFFFFF FFFFFFFF	C0000000 00000000 C0000000 00000000
32 <sup>nd</sup> value	3FFFFFFF FFFFFFFF 3FFFFFFF FFFFFFFF	00000000 00000000 00000000 00000000
Add to invalidate written values <sup>2)</sup>	FFFFFFFF FFFFFFFF FFFFFFFF FFFFFFFE	Same as before, but ECC2-faulty

- 1) ECC-clean and parity-clean (ECC bits and parity bits all stay erased), except where indicated otherwise.
- 2) This write data can be written on any of the states above (except the completely erased state), always resulting in an unchanged data content, but now with an ECC2 error (three ECC bits and one parity bit are written).

Other combinations of write values are possible, too, as long as the basic “add two identical bits in each of two words” is adhered to. In [Table 8-4](#) it is also shown that an invalidation of the data by deliberately creating an ECC2 error is possible.

To minimize the write times and also to minimize the cycle load of the block, it is important to only write the new bits of the block as shown in [Table 8-4](#). In principle it is possible to repeatedly write also the already written bits again, but this would unnecessarily increase the writing times and would also increase the cycle load.

### 8.8.5 Sleep Mode

Assumption: Active mode (`NVMSTATUS.SLEEP = 0B`) and `NVMSTATUS.BUSY = 0B`.

#### To Enter Sleep Mode

1. Execute WFE/WFI or `NVMCONF.NVM_ON = 0B`.
2. `NVMSTATUS.BUSY = 1B` and `NVMSTATUS.SLEEP = 1B` until sleep mode is reached.
3. `NVMSTATUS.BUSY = 0B` and `NVMSTATUS.SLEEP = 1B` while in sleep mode.

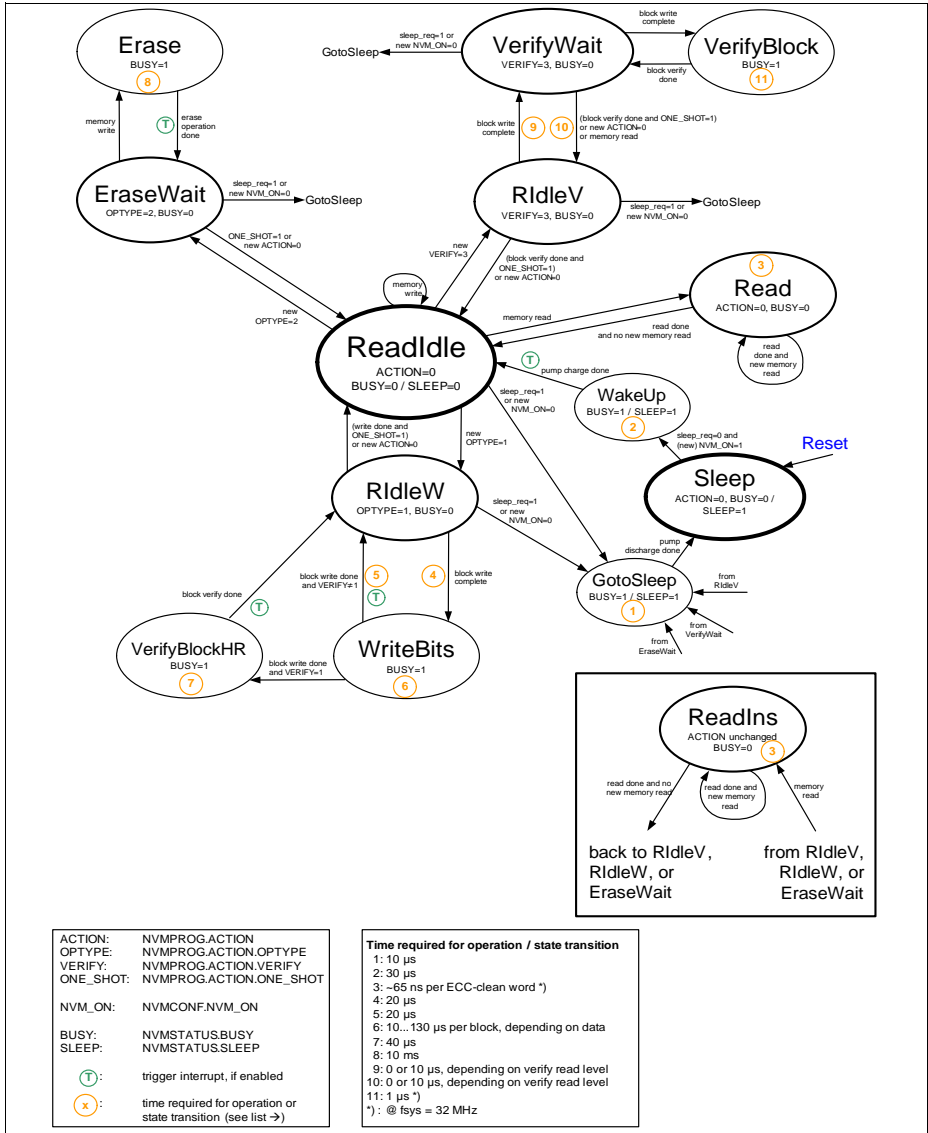
#### To Wake-up from Sleep Mode

1. Any wake-up event and `NVMCONF.NVM_ON = 1B`.
2. `NVMSTATUS.BUSY = 1B` and `NVMSTATUS.SLEEP = 1B` until active mode is reached.
3. `NVMSTATUS.BUSY = 0B` and `NVMSTATUS.SLEEP = 0B` while in active mode.

A wake-up event while the goto sleep sequence has not finished yet, does not shorten this sequence, but only directly starts the wake-up sequence afterwards.

### 8.8.6 Timing

This state diagram shows the transitions and timings of all possible sequences.



**Figure 8-4 State Diagram of the NVM Module Timings are preliminary**

## 9 Peripheral Access Unit (PAU)

The Peripheral Access Unit (PAU) supports access control of memories and peripherals in a central place.

### 9.1 Features

The PAU provides the following features:

- Allows user application to enable/disable the access to the registers of a peripheral
- Generates a HardFault exception when there is an access to a disabled or unassigned address location
- Provides information on availability of peripherals and size of memories

### 9.2 Peripheral Privilege Access Control

The user application can use the Peripheral Privilege Access Registers, PRIVDISn, to disable access to a peripheral. When the PDISx bit corresponding to the peripheral is set, the memory address space mapped to the peripheral is rendered invalid. An access to such an invalid address causes a HardFault exception.

The application can clear the same bit to enable accesses to the peripheral again.

**Table 9-1** shows the peripherals and their assigned PDISx bits. Peripherals without a PDISx bit are accessible at all times.

**Table 9-1 Peripherals Availability and Privilege Access Control**

Peripheral	Address Grouping	AVAILn.AVAILx bit	PRIVDIS.PDISx bit
Flash	Flash SFRs	-	PRIVDIS0.2
SRAM	RAM Block 1	AVAIL0.5	PRIVDIS0.5
	RAM Block 2	AVAIL0.6	PRIVDIS0.6
	RAM Block 3	AVAIL0.7	PRIVDIS0.7
WDT	WDT	-	PRIVDIS0.19
Ports	Port 0	AVAIL0.22	PRIVDIS0.22
	Port 1	AVAIL0.23	PRIVDIS0.23
	Port 2	AVAIL0.24	PRIVDIS0.24
USIC0	USIC0_CH0	AVAIL1.0	PRIVDIS1.0
	USIC0_CH1	AVAIL1.1	PRIVDIS1.1
PRNG	PRNG	AVAIL1.4	-

**Table 9-1 Peripherals Availability and Privilege Access Control**

<b>Peripheral</b>	<b>Address Grouping</b>	<b>AVAILn.AVAILx bit</b>	<b>PRIVDIS.PDISx bit</b>
VADC0	VADC0 Basic SFRs	AVAIL1.5	PRIVDIS1.5
	VADC0 Group 0 SFRs	AVAIL1.6	PRIVDIS1.6
	VADC0 Group 1 SFRs	AVAIL1.7	PRIVDIS1.7
SHS0	SHS0	AVAIL1.8	PRIVDIS1.8
CCU4	CC40 and CCU40 Kernel SFRs	AVAIL1.9	PRIVDIS1.9
	CC41	AVAIL1.10	PRIVDIS1.10
	CC42	AVAIL1.11	PRIVDIS1.11
	CC43	AVAIL1.12	PRIVDIS1.12
LEDTS0	LEDTS0 Sync Master	AVAIL2.13	PRIVDIS2.13
LEDTS1	LEDTS1 Sync Slave	AVAIL2.14	PRIVDIS2.14
BCCU0	BCCU0	AVAIL2.15	PRIVDIS2.15

### **9.3 Peripheral Availability and Memory Size**

The availability of peripherals and memory sizes varies according to product variants. The user application can read the Peripheral Availability Registers, AVAILn, to check for the availability of peripherals in a product variant. Refer to [Table 9-1](#) for the bit assignment. Similarly, the Memory Size Registers (e.g. FLSIZE for Flash memory) can be used to check for the size of the available memories.



## 9.4 PAU Registers

### Registers Overview

The absolute register address is calculated by adding:  
Module Base Address + Offset Address

**Table 9-2 Registers Address Space**

Module	Base Address	End Address	Note
PAU	4000 0000 <sub>H</sub>	4000 FFFF <sub>H</sub>	

**Table 9-3 Register Overview**

Short Name	Description	Offset Addr.	Access Mode		Description See
			Read	Write	
Reserved	Reserved	0000 <sub>H</sub> - 003C <sub>H</sub>	nBE	nBE	
AVAIL0	Peripheral Availability Register 0	0040 <sub>H</sub>	U, PV	BE	<a href="#">Page 9-7</a>
AVAIL1	Peripheral Availability Register 1	0044 <sub>H</sub>	U, PV	BE	<a href="#">Page 9-8</a>
AVAIL2	Peripheral Availability Register 2	0048 <sub>H</sub>	U, PV	BE	<a href="#">Page 9-10</a>
Reserved	Reserved	004C <sub>H</sub> - 007C <sub>H</sub>	nBE	nBE	
PRIVDIS0	Peripheral Privilege Access Register 0	0080 <sub>H</sub>	U, PV	U, PV	<a href="#">Page 9-4</a>
PRIVDIS1	Peripheral Privilege Access Register 1	0084 <sub>H</sub>	U, PV	U, PV	<a href="#">Page 9-5</a>
PRIVDIS2	Peripheral Privilege Access Register 2	0088 <sub>H</sub>	U, PV	U, PV	<a href="#">Page 9-6</a>
Reserved	Reserved	008C <sub>H</sub> - 03FC <sub>H</sub>	nBE	nBE	
ROMSIZE	ROM Size Register	0400 <sub>H</sub>	U, PV	BE	<a href="#">Page 9-11</a>
FLSIZE	Flash Size Register	0404 <sub>H</sub>	U, PV	BE	<a href="#">Page 9-11</a>
RAMOSIZE	RAM0 Size Register	0410 <sub>H</sub>	U, PV	BE	<a href="#">Page 9-12</a>

**Peripheral Access Unit (PAU)**

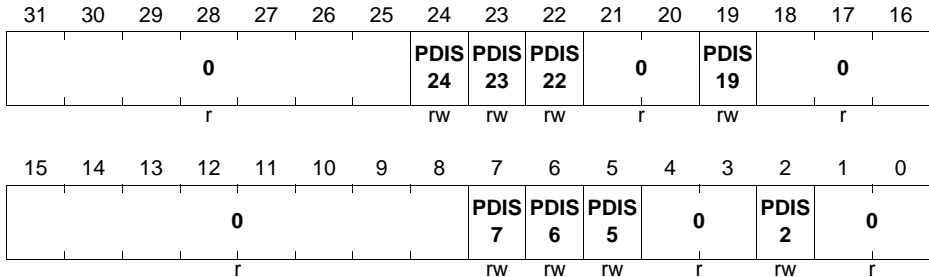
### 9.4.1 Peripheral Privilege Access Registers (PRIVDISn)

The PRIVDISn registers provide the bit to enable and disable access to a peripheral during runtime. When disabled, an access to the peripheral throws a BusFault.

#### PRIVDIS0

##### Peripheral Privilege Access Register 0 (0080<sub>H</sub>)

Reset Value: 0000 0000<sub>H</sub>



Field	Bits	Type	Description
<b>PDIS2</b>	2	rw	<b>Flash SFRs Privilege Disable Flag</b> 0 <sub>B</sub> Flash SFRs are accessible. 1 <sub>B</sub> Flash SFRs are not accessible.
<b>PDIS5</b>	5	rw	<b>RAM Block 1 Privilege Disable Flag</b> 0 <sub>B</sub> RAM Block 1 is accessible. 1 <sub>B</sub> RAM Block 1 is not accessible.
<b>PDIS6</b>	6	rw	<b>RAM Block 2 Privilege Disable Flag</b> 0 <sub>B</sub> RAM Block 2 is accessible. 1 <sub>B</sub> RAM Block 2 is not accessible.
<b>PDIS7</b>	7	rw	<b>RAM Block 3 Privilege Disable Flag</b> 0 <sub>B</sub> RAM Block 3 is accessible. 1 <sub>B</sub> RAM Block 3 is not accessible.
<b>PDIS19</b>	19	rw	<b>WDT Privilege Disable Flag</b> 0 <sub>B</sub> WDT is accessible. 1 <sub>B</sub> WDT is not accessible.
<b>PDIS22</b>	22	rw	<b>Port 0 Privilege Disable Flag</b> 0 <sub>B</sub> Port 0 is accessible. 1 <sub>B</sub> Port 0 is not accessible.
<b>PDIS23</b>	23	rw	<b>Port 1 Privilege Disable Flag</b> 0 <sub>B</sub> Port 1 is accessible. 1 <sub>B</sub> Port 1 is not accessible.

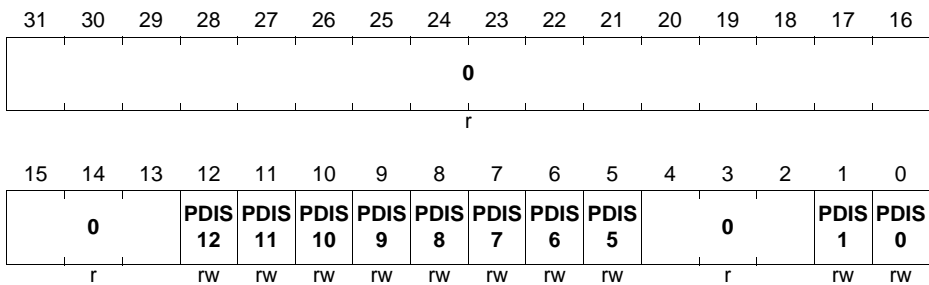
**Peripheral Access Unit (PAU)**

Field	Bits	Type	Description
<b>PDIS24</b>	24	rw	<b>Port 2 Privilege Disable Flag</b> 0 <sub>B</sub> Port 2 is accessible. 1 <sub>B</sub> Port 2 is not accessible.
<b>0</b>	[31:25], [21:20], [18:8], [4:3], [1:0]	r	<b>Reserved</b>

**PRIVDIS1**

**Peripheral Privilege Access Register 1 (0084<sub>H</sub>)**

**Reset Value: 0000 0000<sub>H</sub>**



Field	Bits	Type	Description
<b>PDIS0</b>	0	rw	<b>USIC0 Channel 0 Privilege Disable Flag</b> 0 <sub>B</sub> USIC0 Channel 0 is accessible. 1 <sub>B</sub> USIC0 Channel 0 is not accessible.
<b>PDIS1</b>	1	rw	<b>USIC0 Channel 1 Privilege Disable Flag</b> 0 <sub>B</sub> USIC0 Channel 1 is accessible. 1 <sub>B</sub> USIC0 Channel 1 is not accessible.
<b>PDIS5</b>	5	rw	<b>VADC0 Basic SFRs Privilege Disable Flag</b> 0 <sub>B</sub> VADC0 Basic SFRs are accessible. 1 <sub>B</sub> VADC0 Basic SFRs are not accessible.
<b>PDIS6</b>	6	rw	<b>VADC0 Group 0 SFRs Privilege Disable Flag</b> 0 <sub>B</sub> VADC0 Group 0 SFRs are accessible. 1 <sub>B</sub> VADC0 Group 0 SFRs are not accessible.

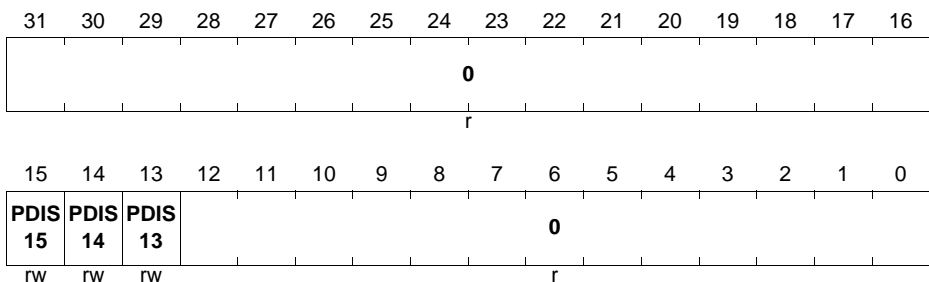
**Peripheral Access Unit (PAU)**

Field	Bits	Type	Description
<b>PDIS7</b>	7	rw	<b>VADC0 Group 1 SFRs Privilege Disable Flag</b> 0 <sub>B</sub> VADC0 Group 1 SFRs are accessible. 1 <sub>B</sub> VADC0 Group 1 SFRs are not accessible.
<b>PDIS8</b>	8	rw	<b>SHS0 Privilege Disable Flag</b> 0 <sub>B</sub> SHS0 is accessible. 1 <sub>B</sub> SHS0 is not accessible.
<b>PDIS9</b>	9	rw	<b>CC40 and CCU40 Kernel SFRs Privilege Disable Flag</b> 0 <sub>B</sub> CC40 and CCU40 Kernel SFRs are accessible. 1 <sub>B</sub> CC40 and CCU40 Kernel SFRs are not accessible.
<b>PDIS10</b>	10	rw	<b>CC41 Privilege Disable Flag</b> 0 <sub>B</sub> CC41 is accessible. 1 <sub>B</sub> CC41 is not accessible.
<b>PDIS11</b>	11	rw	<b>CC42 Privilege Disable Flag</b> 0 <sub>B</sub> CC42 is accessible. 1 <sub>B</sub> CC42 is not accessible.
<b>PDIS12</b>	12	rw	<b>CC43 Privilege Disable Flag</b> 0 <sub>B</sub> CC43 is accessible. 1 <sub>B</sub> CC43 is not accessible.
<b>0</b>	[31:13] , [4:2]	r	<b>Reserved</b>

**PRIVDIS2**

**Peripheral Privilege Access Register 2 (0088<sub>H</sub>)**

**Reset Value: 0000 0000<sub>H</sub>**



Field	Bits	Type	Description
<b>PDIS13</b>	13	rw	<b>LEDTS0 Sync Master Privilege Disable Flag</b> 0 <sub>B</sub> LEDTS0 Sync Master is accessible. 1 <sub>B</sub> LEDTS0 Sync Master is not accessible.
<b>PDIS14</b>	14	rw	<b>LEDTS1 Sync Slave Privilege Disable Flag</b> 0 <sub>B</sub> LEDTS1 Sync Slave is accessible. 1 <sub>B</sub> LEDTS1 Sync Slave is not accessible.
<b>PDIS15</b>	15	rw	<b>BCCU0 Privilege Disable Flag</b> 0 <sub>B</sub> BCCU0 is accessible. 1 <sub>B</sub> BCCU0 is not accessible.
<b>0</b>	[31:16] , [12:0]	r	<b>Reserved</b>

## 9.4.2 Peripheral Availability Registers (AVAILn)

The AVAILn registers indicate the available peripherals for the particular device variant.

*Note: The reset values of AVAILn registers show the configuration with all peripherals available. Actual values might differ depending on the product variant.*

### AVAIL0

**Peripheral Availability Register 0 (0040<sub>H</sub>)**      **Reset Value: 01CF 00FF<sub>H</sub>**

31	30	29	28	27	26	25	24	23	22	21	20	19	18	17	16
0							AVAI L24	AVAI L23	AVAI L22	0	1				
r							r	r	r	r	r				
15	14	13	12	11	10	9	8	7	6	5	4	3	2	1	0
0							AVAI L7	AVAI L6	AVAI L5	1					
r							r	r	r	r					

Field	Bits	Type	Description
<b>AVAIL5</b>	5	r	<b>RAM Block 1 Availability Flag</b> 0 <sub>B</sub> RAM block 1 is not available. 1 <sub>B</sub> RAM block 1 is available.

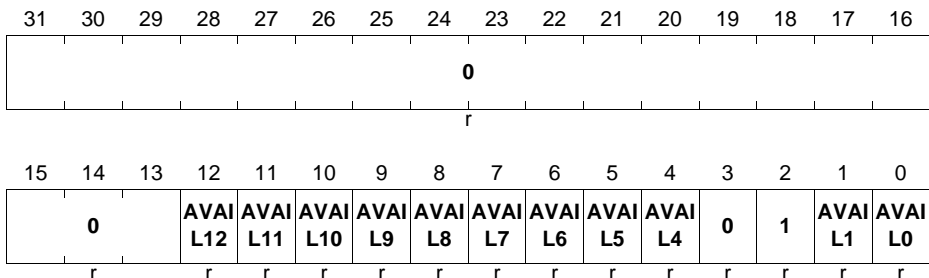
**Peripheral Access Unit (PAU)**

Field	Bits	Type	Description
<b>AVAIL6</b>	6	r	<b>RAM Block 2 Availability Flag</b> 0 <sub>B</sub> RAM block 2 is not available. 1 <sub>B</sub> RAM block 2 is available.
<b>AVAIL7</b>	7	r	<b>RAM Block 3 Availability Flag</b> 0 <sub>B</sub> RAM block 3 is not available. 1 <sub>B</sub> RAM block 3 is available.
<b>AVAIL22</b>	22	r	<b>Port 0 Availability Flag</b> 0 <sub>B</sub> Port 0 is not available. 1 <sub>B</sub> Port 0 is available.
<b>AVAIL23</b>	23	r	<b>Port 1 Availability Flag</b> 0 <sub>B</sub> Port 1 is not available. 1 <sub>B</sub> Port 1 is available.
<b>AVAIL24</b>	24	r	<b>Port 2 Availability Flag</b> 0 <sub>B</sub> Port 2 is not available. 1 <sub>B</sub> Port 2 is available.
<b>1</b>	[19:16] , [4:0]	r	<b>Reserved</b>
<b>0</b>	[31:25] , [21:20] , [15:8]	r	<b>Reserved</b>

**AVAIL1**

**Peripheral Availability Register 1 (0044<sub>H</sub>)**

**Reset Value: 0000 1FF7<sub>H</sub>**



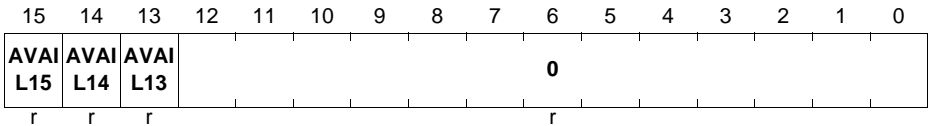
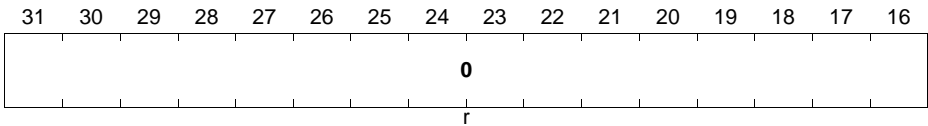
**Peripheral Access Unit (PAU)**

Field	Bits	Type	Description
<b>AVAIL0</b>	0	r	<b>USIC0 Channel 0 Availability Flag</b> 0 <sub>B</sub> USIC0 Channel 0 is not available. 1 <sub>B</sub> USIC0 Channel 0 is available.
<b>AVAIL1</b>	1	r	<b>USIC0 Channel 1 Availability Flag</b> 0 <sub>B</sub> USIC0 Channel 1 is not available. 1 <sub>B</sub> USIC0 Channel 1 is available.
<b>AVAIL4</b>	4	r	<b>PRNG Availability Flag</b> 0 <sub>B</sub> PRNG is not available. 1 <sub>B</sub> PRNG is available.
<b>AVAIL5</b>	5	r	<b>VADC0 Basic SFRs Availability Flag</b> 0 <sub>B</sub> VADC0 Basic SFRs are not available. 1 <sub>B</sub> VADC0 Basic SFRs are available.
<b>AVAIL6</b>	6	r	<b>VADC0 Group 0 SFRs Availability Flag</b> 0 <sub>B</sub> VADC0 Group 0 SFRs are not available. 1 <sub>B</sub> VADC0 Group 0 SFRs are available.
<b>AVAIL7</b>	7	r	<b>VADC0 Group 1 SFRs Availability Flag</b> 0 <sub>B</sub> VADC0 Group 1 SFRs are not available. 1 <sub>B</sub> VADC0 Group 1 SFRs are available.
<b>AVAIL8</b>	8	r	<b>SHS0 Availability Flag</b> 0 <sub>B</sub> SHS0 is not available. 1 <sub>B</sub> SHS0 is available.
<b>AVAIL9</b>	9	r	<b>CC40 Availability Flag</b> 0 <sub>B</sub> CC40 is not available. 1 <sub>B</sub> CC40 is available.
<b>AVAIL10</b>	10	r	<b>CC41 Availability Flag</b> 0 <sub>B</sub> CC41 is not available. 1 <sub>B</sub> CC41 is available.
<b>AVAIL11</b>	11	r	<b>CC42 Availability Flag</b> 0 <sub>B</sub> CC42 is not available. 1 <sub>B</sub> CC42 is available.
<b>AVAIL12</b>	12	r	<b>CC43 Availability Flag</b> 0 <sub>B</sub> CC43 is not available. 1 <sub>B</sub> CC43 is available.
<b>1</b>	2	r	<b>Reserved</b>
<b>0</b>	[31:13] , 3	r	<b>Reserved</b>

**Peripheral Access Unit (PAU)**

**AVAIL2**

**Peripheral Availability Register 2 (0048<sub>H</sub>)**      **Reset Value: 0000 E000<sub>H</sub>**



Field	Bits	Type	Description
<b>AVAIL13</b>	13	r	<b>LEDTS0 Sync Master Availability Flag</b> 0 <sub>B</sub> LEDTS0 Sync Master is not available. 1 <sub>B</sub> LEDTS0 Sync Master is available.
<b>AVAIL14</b>	14	r	<b>LEDTS1 Sync Slave Availability Flag</b> 0 <sub>B</sub> LEDTS0 Sync Slave is not available. 1 <sub>B</sub> LEDTS0 Sync Slave is available.
<b>AVAIL15</b>	15	r	<b>BCCU0 Availability Flag</b> 0 <sub>B</sub> BCCU0 is not available. 1 <sub>B</sub> BCCU0 is available.
<b>0</b>	[31:16] , [12:0]	r	<b>Reserved</b>

**9.4.3 Memory Size Registers**

Memory size registers are available for the ROM, SRAM and Flash memories. They are used to indicate the available size of these memories in the device.

*Note: The reset values of the size registers show the configuration of the superset device. Actual values might differ depending on the product variant.*



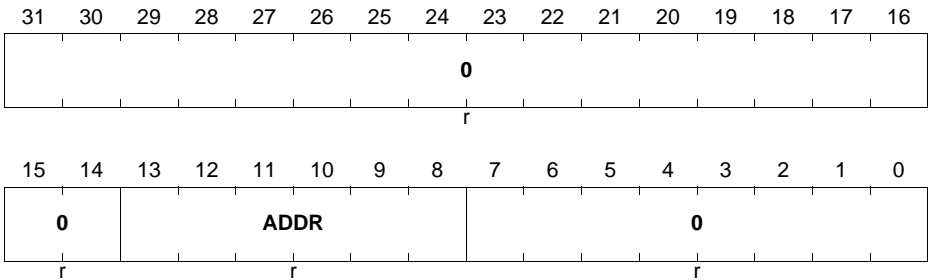
**Peripheral Access Unit (PAU)**

**ROMSIZE**

**ROM Size Register**

**(0400<sub>H</sub>)**

**Reset Value: 0000 0B00<sub>H</sub>**



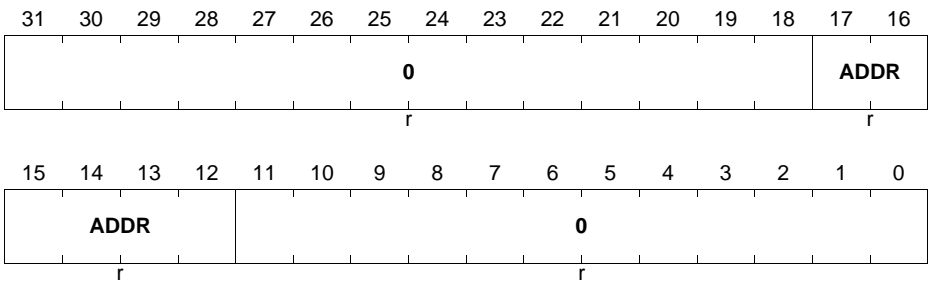
Field	Bits	Type	Description
ADDR	[13:8]	r	<b>ROM Size</b> Size of user-readable ROM in bytes = ADDR * 256
0	[31:14], [7:0]	r	<b>Reserved</b>

**FLSIZE**

**Flash Size Register**

**(0404<sub>H</sub>)**

**Reset Value: 0003 3000<sub>H</sub>**



Field	Bits	Type	Description
ADDR	[17:12]	r	<b>Flash Size</b> Size of the Flash (excluding Flash sector 0) in Kbytes = (ADDR - 1) * 4

**Peripheral Access Unit (PAU)**

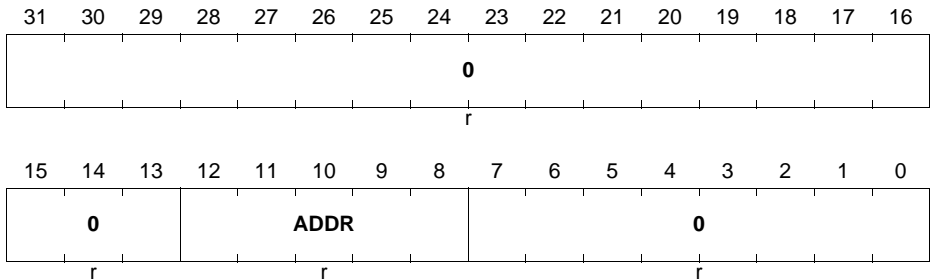
Field	Bits	Type	Description
<b>0</b>	[31:18] , [11:0]	r	<b>Reserved</b>

**RAM0SIZE**

**RAM0 Size Register**

**(0410<sub>H</sub>)**

**Reset Value: 0000 1000<sub>H</sub>**



Field	Bits	Type	Description
<b>ADDR</b>	[12:8]	r	<b>RAM0 Size</b> Size of RAM block 0 in bytes = ADDR * 256 For total RAM size, RAM blocks 1 to 3 have to be also taken into consideration.
<b>0</b>	[31:13] , [7:0]	r	<b>Reserved</b>

# **System Control**

## 10 Window Watchdog Timer (WDT)

Purpose of the Window Watchdog Timer module is improvement of system integrity. WDT triggers the system reset or other corrective action like e.g. an interrupt if the main program, due to some fault condition, neglects to regularly service the watchdog (also referred to as “kicking the dog”, “petting the dog”, “feeding the watchdog” or “waking the watchdog”). The intention is to bring the system back from the unresponsive state into normal operation.

### References

[6] Cortex-M0 User Guide, ARM DUI 0467B (ID081709)

### 10.1 Overview

A successful servicing of the WDT results in a pulse on the signal `wdt_service`. The signal is offered also as an alternate function output can be used to show to an external watchdog that the system is alive.

The WDT timer is a 32-bit counter, which counts up from  $0_H$ . It can be serviced while the counter value is within the window boundary, i.e. between the lower and the upper boundary value. Correct servicing results in a reset of the counter to  $0_H$ . A so called “Bad Service” attempt results in the system reset request.

The timer block is running on the  $f_{WDT}$  clock which is independent from the bus clock. The timer value is updated in the corresponding AHB register **TIM**. This mechanism enables immediate response on a read access from the bus.

#### 10.1.1 Features

The watchdog timer (WDT) is an independent window watchdog timer.

The features are:

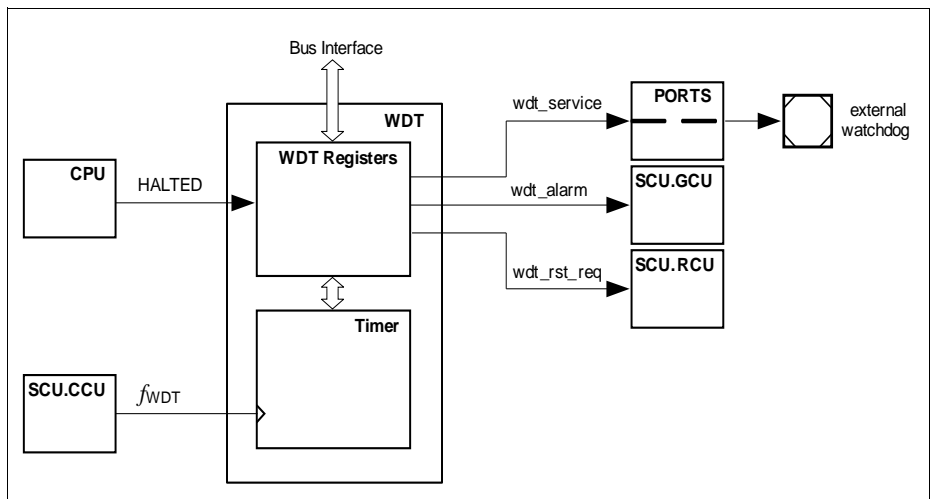
- Triggers system reset when not serviced on time or serviced in a wrong way
- Servicing restricted to be within boundaries of refresh window
- Can run from an independent clock
- Provides service indication to an external pin
- Can be suspended in halting mode
- Provides optional pre-warning alarm before reset

**Table 10-1 Application Features**

Feature	Purpose/Application
System reset upon Bad Servicing	Triggered to restore system stable operation and ensure system integrity
Servicing restricted to be within defined boundaries of refresh window	Allows to consider minimum and maximum software timing
Independent clocks	To ensure that WDT counts even in case of the system clock failure
Service indication on external pin	For dual-channel watchdog solution, additional external control of system integrity
Suspending in HALT mode	Enables safe debugging with productive code
Pre-warning alarm	Software recovery to allow corrective action via software recovery routine bringing system back from the unresponsive state into normal operation

### 10.1.2 Block Diagram

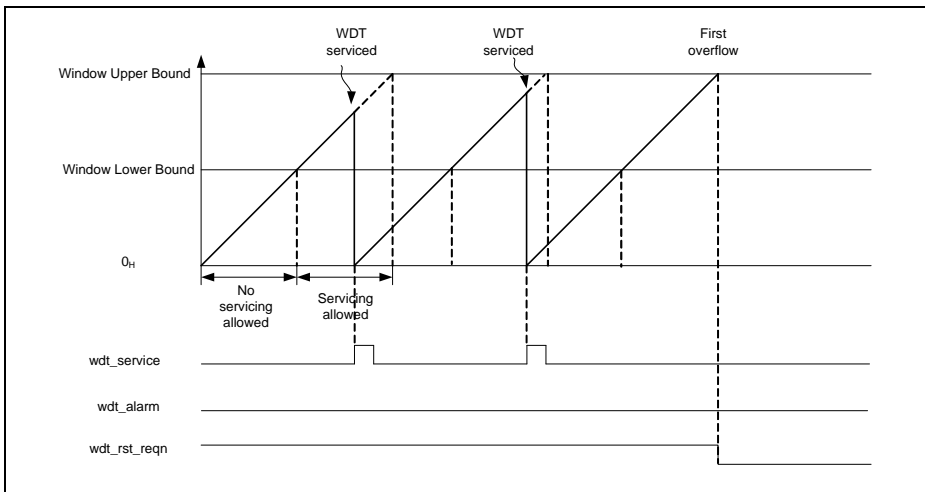
The WDT block diagram is shown in [Figure 10-1](#).



**Figure 10-1 Watchdog Timer Block Diagram**

## 10.2 Time-Out Mode

An overflow results in an immediate reset request going to the RCU of the SCU via the signal `wdt_rst_req` whenever the counter crosses the upper boundary it triggers an overflow event pre-warning is not enabled with **CTR** register. A successful servicing performed with writing a unique value, referred to as “Magic Word” to the **SRV** register of the WDT within the valid servicing window, results in a pulse on the signal `wdt_service` and reset of the timer counter.



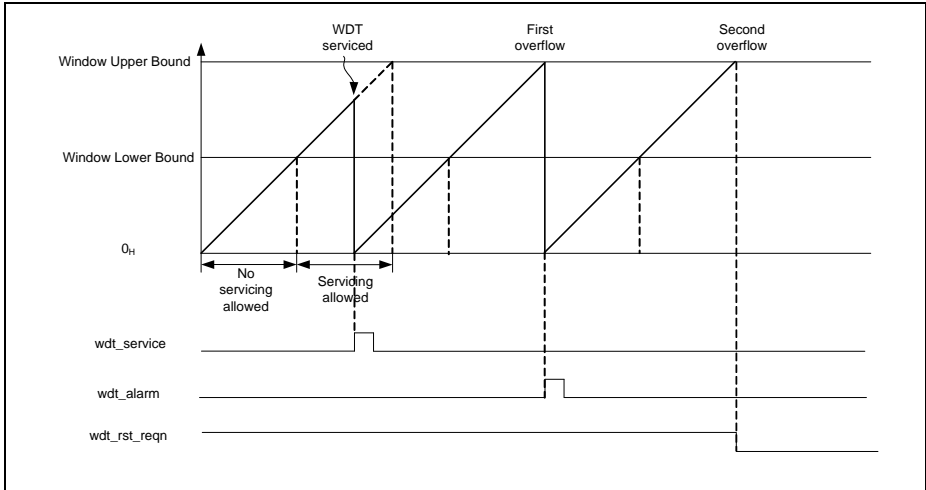
**Figure 10-2 Reset without pre-warning**

The example scenario depicted in **Figure 10-2** shows two consecutive service pulses generated from WDT module as the result of successful servicing within valid time windows. The situation where no service has been performed immediately triggers generation of reset request on the `wdt_rst_req` output after the counter value has exceeded window upper bound value.

## 10.3 Pre-warning Mode

While in pre-warning mode the effect of the overflow event is different with and without pre-warning enabled. The first crossing of the upper bound triggers the outgoing alarm signal `wdt_alarm` when pre-warning is enabled. Only the next overflow results a reset request. The alarm status is shown via register **WDTSTS** and can be cleared via register **WDTCLR**. A clear of the alarm status will bring the WDT back to normal state.

**Window Watchdog Timer (WDT)**



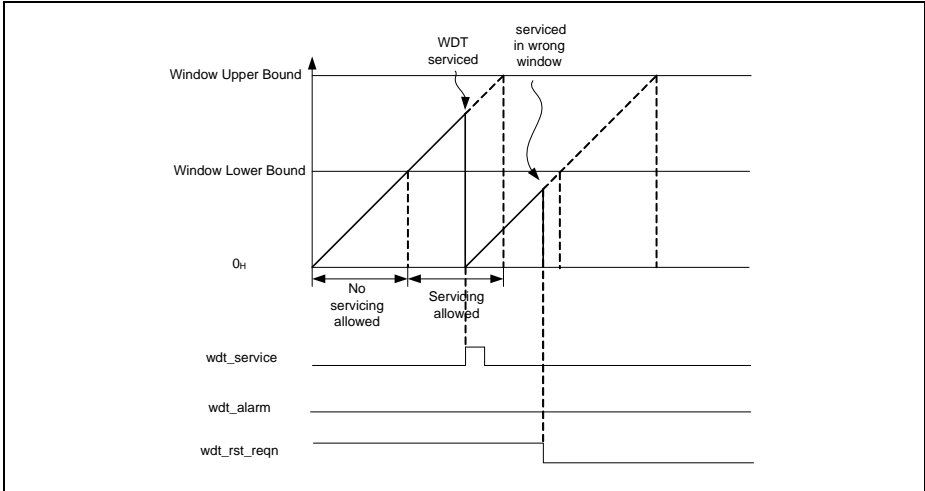
**Figure 10-3 Reset after pre-warning**

The example scenario depicted in [Figure 10-3](#) shows service pulse generated from WDT module as the result of successful servicing within valid time window. WDT generates alarm pulse on `wdt_alarm` upon first missing servicing. The alarm signal is routed as interrupt request to the SCU. Within this alarm service request the user can clear the WDT status bit and give a proper WDT service before it overflows next time. Otherwise WDT generates reset request on `wdt_rstn` upon the second missing service.

### 10.4 Bad Service Operation

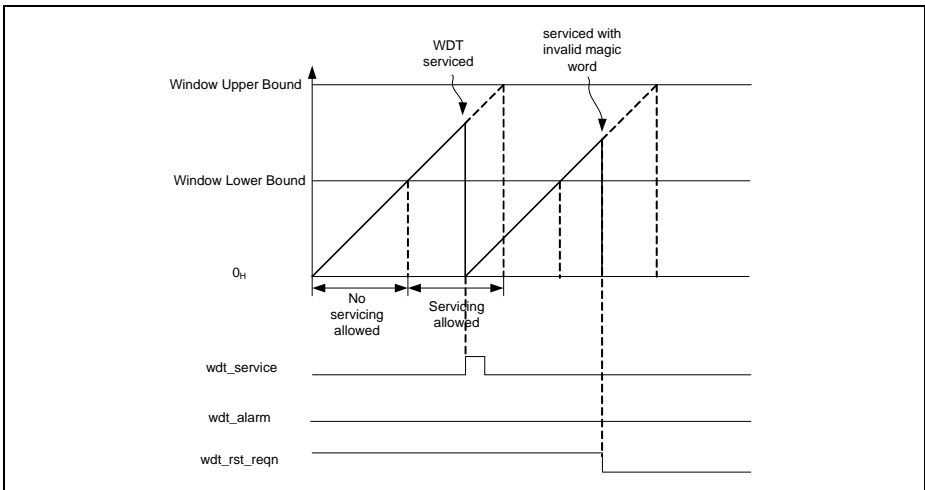
A bad service attempt results in a reset request. A bad service attempt can be due to servicing outside the window boundaries or servicing with an invalid Magic Word.

Window Watchdog Timer (WDT)



**Figure 10-4 Reset upon servicing in a wrong window**

The example in [Figure 10-4](#) shows servicing performed outside of valid servicing window. Attempt to service WDT while counter value remains below the window lower bound results in immediate reset request on wdt\_rst\_req signal.



**Figure 10-5 Reset upon servicing with a wrong magic word**



## Window Watchdog Timer (WDT)

The example in [Figure 10-5](#) shows servicing performed within a valid servicing window but with an invalid Magic Word. Attempt to write a wrong word to the **SRV** register results in immediate reset request on `wdt_rst_req` signal.

### 10.5 Service Request Processing

The WDT generates watchdog alarm service requests via `wdt_alarm` output signal upon first counter overflow over watchdog upper bound when pre-warning mode is enabled. The alarm service request is serviced in SCU.

Service requests can be disabled respectively by service request mask register in SCU.

### 10.6 Debug Behavior

The WDT function can be suspended when the CPU enters HALT mode. WDT debug function is controlled with DSP bit field in **CTR** register and it is set to be suspended by default.

### 10.7 Power, Reset and Clock

The WDT module is a part of the core domain and supplied with  $V_{\text{DDC}}$  voltage.

All WDT registers get reset with the system reset.

A sticky bit in the Reset Status Register, **RSTSTAT**, of SCU/RCU module indicates whether the last system reset has been triggered by the WDT module. This bit does not get reset with system reset.

The input clock of the WDT counter is provided by the internal 32kHz standby clock from SCU/CCU module, independently from the AHB interface clock.

The WDT module clock is default disabled and can be enabled via the **SCU\_CGATCLR0** register. Enabling and disabling the module clock could cause load change and clock blanking could happen as explained in the CCU (Clock Gating Control) section of the SCU chapter. It is strongly recommended to setup the module clock in the user initialisation code to avoid clock blanking during runtime.

### 10.8 Initialization and Control Sequence

Programming model of the WDT module assumes several scenarios where different control sequences apply.

*Note:* Some of the scenarios described in this chapter require operations on system level that are not in the scope of the WDT module description, therefore for detailed information please refer to relevant chapters of this document.

#### 10.8.1 Initialization & Start of Operation

Complete WDT module initialization is required upon system reset.

---

**Window Watchdog Timer (WDT)**

- check reason for last system reset in order to determine power state
  - read out SCU\_RSTSTAT.RSTSTAT register bit field to determine last system reset cause and clear this bit using bit SCU\_RSTCLR.RSCLR
  - perform appropriate operations dependent on the last system reset cause
- WDT software initialization sequence
  - enable WDT clock with SCU\_CGATCLR0.WDT register bit field
  - set lower window bound with WDT\_WLB register
  - set upper window bound with WDT\_WUB register
  - configure external watchdog service indication (optional, please refer to PORT chapter)
  - enable interrupt for pre-warning alarm on system level with SCU\_SRMSK register (optional, used in WDT pre-warning mode only)
- software start sequence
  - select mode (Time-Out or Pre-warning) and enable WDT module with WDT\_CTR register
- service the watchdog
  - write magic word to WDT\_SRV register within valid time window

### **10.8.2 Software Stop & Resume Operation**

The WDT module can be stopped and re-started at any point of time for e.g. debug purpose using software sequence.

- software stop sequence
  - disable WDT module with WDT\_CTR register
- perform any user operations
- software start (resume) sequence
  - enable WDT module with WDT\_CTR register with WDT\_CTR register
- service the watchdog
  - write magic word to WDT\_SRV register within valid time window

### **10.8.3 Enter Sleep/Deep-Sleep & Resume Operation**

The WDT counter clock can be configured to stop while in sleep or deep-sleep mode. No direct software interaction with the WDT is required in those modes and no watchdog time-out will fire if the WDT clock is configured to stop while CPU is sleeping.

- software configuration sequence for sleep/deep-sleep mode
  - configure WDT behavior with SCU\_CGATx register
- enter sleep/deep-sleep mode software sequence

## **Window Watchdog Timer (WDT)**

- select sleep or deep-sleep mode in CPU (for details please refer to Cortex-M0 documentation [6])
- enter selected mode (for details please refer to Cortex-M0 documentation [6])
- wait for a wake-up event (no software interaction, CPU stopped)
- resume operation (CPU clock restarted automatically on an event)
- service the watchdog
  - write magic word to WDT\_SRV register within valid time window

### **10.8.4 Pre-warning Alarm Handling**

The WDT will fire pre-warning alarm before requesting system reset while in pre-warning mode and not serviced within valid time window. The WDT status register indicating alarm must be cleared before the timer counter value crosses the upper bound for the second time after firing the alarm. After clearing of the alarm status regular watchdog servicing must be performed within valid time window.

- alarm event
  - exception routine (service request) clearing WDT\_WDTSTAT register with WDT\_WDTCLR register
- service the watchdog
  - write magic word to WDT\_SRV register within valid time window

## 10.9 WDT Registers

### Registers Overview

The absolute register address is calculated by adding:  
Module Base Address + Offset Address

**Table 10-2 Registers Address Space**

Module	Base Address	End Address	Note
WDT	4002 0000 <sub>H</sub>	4002 FFFF <sub>H</sub>	Watchdog Timer Registers

**Table 10-3 Register Overview**

Short Name	Description	Offset Addr.	Access Mode		Description See
			Read	Write	
WDT Kernel Registers					
ID	Module ID Register	00 <sub>H</sub>	U, PV	PV	<a href="#">Page 10-9</a>
CTR	Control Register	04 <sub>H</sub>	U, PV	PV	<a href="#">Page 10-10</a>
SRV	Service Register	08 <sub>H</sub>	BE	PV	<a href="#">Page 10-11</a>
TIM	Timer Register	0C <sub>H</sub>	U, PV	BE	<a href="#">Page 10-13</a>
WLB	Window Lower Bound	10 <sub>H</sub>	U, PV	PV	<a href="#">Page 10-13</a>
WUB	Window Upper Bound	14 <sub>H</sub>	U, PV	PV	<a href="#">Page 10-14</a>
WDTSTS	Watchdog Status Register	18 <sub>H</sub>	U, PV	PV	<a href="#">Page 10-14</a>
WDTCLR	Watchdog Status Clear Register	1C <sub>H</sub>	U, PV	PV	<a href="#">Page 10-15</a>

### 10.9.1 Registers Description

#### ID

The module unique ID register.

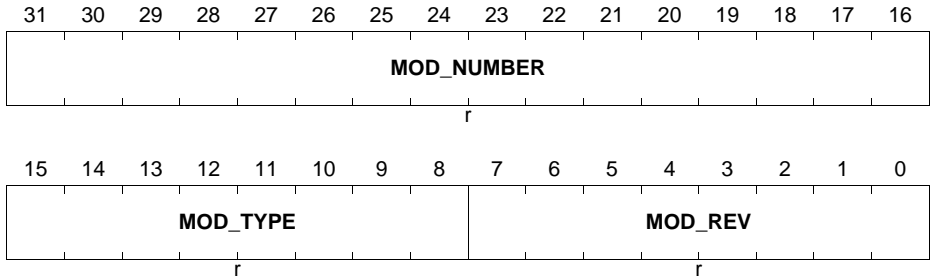
**Window Watchdog Timer (WDT)**

**ID**

**WDT Module ID Register**

(0000<sub>H</sub>)

Reset Value: 00AD C0XX<sub>H</sub>



Field	Bits	Type	Description
MOD_REV	[7:0]	r	<b>Module Revision Number</b> Indicates the revision number of the implementation. The value of a module revision starts with 01 <sub>H</sub> (first revision).
MOD_TYPE	[15:8]	r	<b>Module Type</b> This bit field is fixed to C0 <sub>H</sub> .
MOD_NUMBER	[31:16]	r	<b>Module Number Value</b> This bit field defines the module identification number.

**CTR**

The operation mode control register.

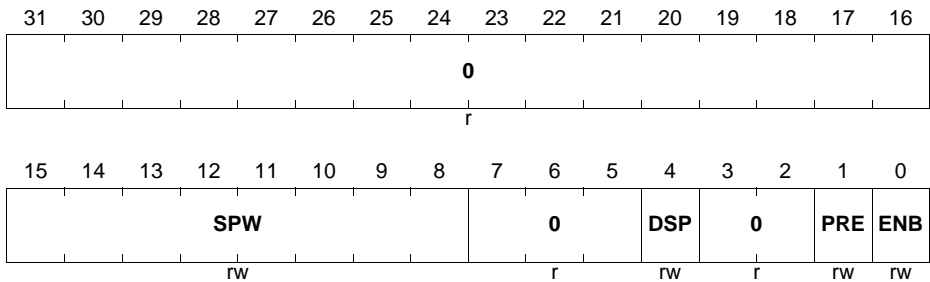
**Window Watchdog Timer (WDT)**

**CTR**

**WDT Control Register**

**(04<sub>H</sub>)**

**Reset Value: 0000 0000<sub>H</sub>**



Field	Bits	Type	Description
<b>ENB</b>	0	rw	<b>Enable</b> 0 <sub>B</sub> disables watchdog timer, 1 <sub>B</sub> enables watchdog timer
<b>PRE</b>	1	rw	<b>Pre-warning</b> 0 <sub>B</sub> disables pre-warning 1 <sub>B</sub> enables pre-warning,
<b>DSP</b>	4	rw	<b>Debug Suspend</b> 0 <sub>B</sub> watchdog timer is stopped during debug halting mode 1 <sub>B</sub> watchdog timer is not stopped during debug halting mode
<b>SPW</b>	[15:8]	rw	<b>Service Indication Pulse Width</b> Pulse width (SPW+1) of service indication in clk_wdt cycles
<b>0</b>	[3:2], [7:5], [31:16]	r	<b>reserved</b>

**SRV**

The WDT service register. Software must write a magic word while the timer value is within the valid window boundary. Writing the magic word while the timer value is within the window boundary will service the watchdog and result a reload of the timer with 0H.

**Window Watchdog Timer (WDT)**

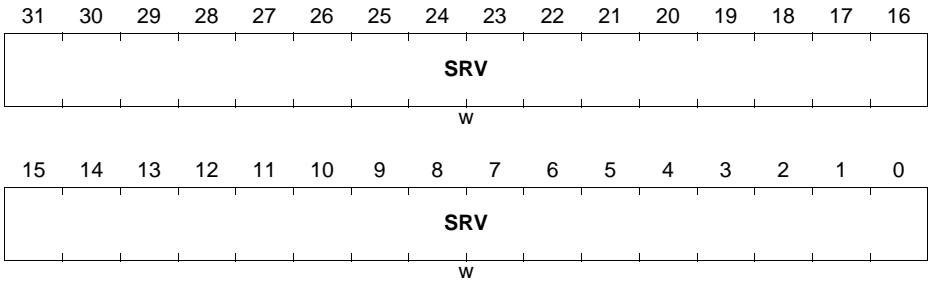
Upon writing data different than the magic word within valid time window or writing even correct Magic Word but outside of the valid time window no servicing will be performed. Instead will request an immediate system reset request.

**SRV**

**WDT Service Register**

**(08<sub>H</sub>)**

**Reset Value: 0000 0000<sub>H</sub>**



Field	Bits	Type	Description
<b>SRV</b>	[31:0]	w	<b>Service</b> Writing the magic word ABADCAFE <sub>H</sub> while the timer value is within the window boundary will service the watchdog.

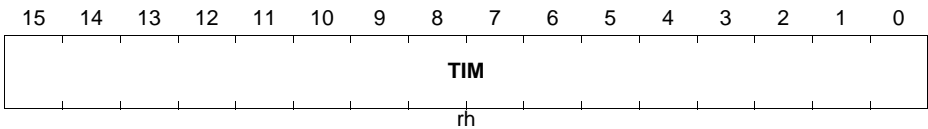
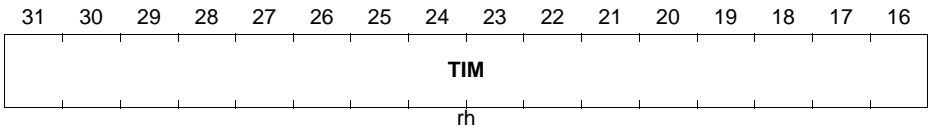
**Window Watchdog Timer (WDT)**

**TIM**

The actual watchdog timer register count value. This register can be read by software in order to determine current position in the WDT time window.

**TIM**

**WDT Timer Register (0C<sub>H</sub>)** **Reset Value: 0000 0000<sub>H</sub>**



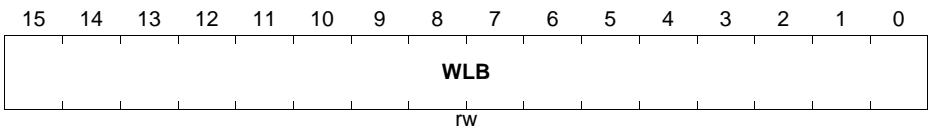
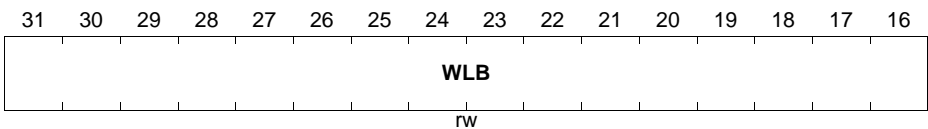
Field	Bits	Type	Description
<b>TIM</b>	[31:0]	rh	<b>Timer Value</b> Actual value of watchdog timer value.

**WLB**

The Window Lower Bound register defines the lower bound for servicing window. Servicing of the watchdog has only effect within the window boundary

**WLB**

**WDT Window Lower Bound Register (10<sub>H</sub>)** **Reset Value: 0000 0000<sub>H</sub>**





**Window Watchdog Timer (WDT)**

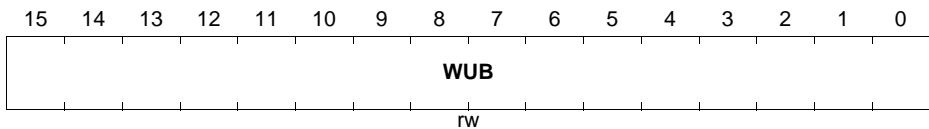
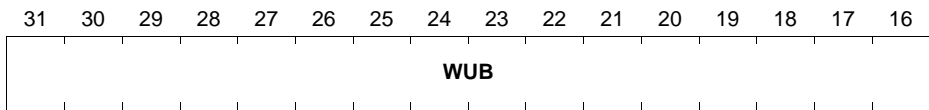
Field	Bits	Type	Description
<b>WLB</b>	[31:0]	rw	<b>Window Lower Bound</b> Lower bound for servicing window. Setting the lower bound to 0 <sub>H</sub> disables the window mechanism.

**WUB**

The Window Upper Bound register defines the upper bound for servicing window. Servicing of the watchdog has only effect within the window boundary.

**WUB**

**WDT Window Upper Bound Register (14<sub>H</sub>)** **Reset Value: FFFF FFFF<sub>H</sub>**



Field	Bits	Type	Description
<b>WUB</b>	[31:0]	rw	<b>Window Upper Bound</b> Upper Bound for servicing window. The WDT triggers a reset request when the timer is crossing the upper bound value without pre-warning enabled. With pre-warning enabled the first crossing triggers a watchdog alarm and the second crossing triggers a system reset.

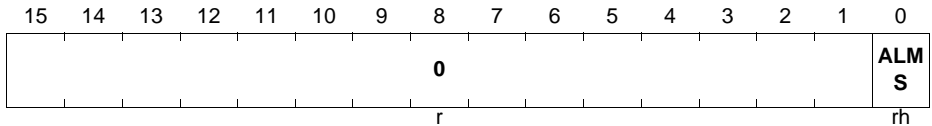
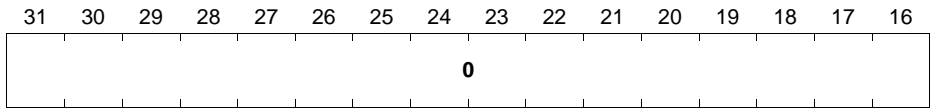
**WDTSTS**

The status register contains sticky bit indicating occurrence of alarm condition.

**Window Watchdog Timer (WDT)**

**WDTSTS**

**WDT Status Register (0018<sub>H</sub>) Reset Value: 00000000<sub>H</sub>**



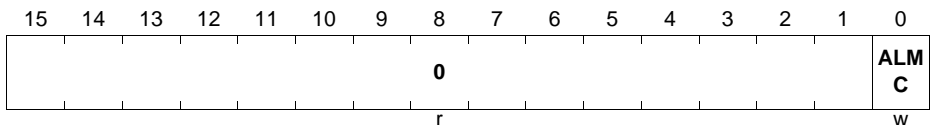
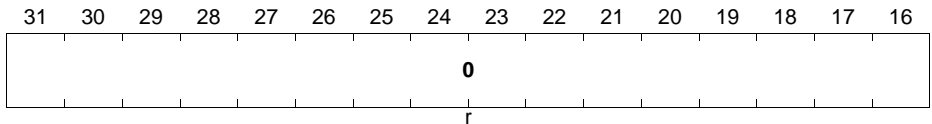
Field	Bits	Type	Description
ALMS	0	rh	<b>Pre-warning Alarm</b> 1 <sub>B</sub> pre-warning alarm occurred, 0 <sub>B</sub> no pre-warning alarm occurred
0	[31:1]	r	<b>reserved</b>

**WDTCLR**

The status register contains sticky bitfield indicating occurrence of alarm condition.

**WDTCLR**

**WDT Clear Register (001C<sub>H</sub>) Reset Value: 00000000<sub>H</sub>**



**Window Watchdog Timer (WDT)**

Field	Bits	Type	Description
<b>ALMC</b>	0	w	<b>Pre-warning Alarm</b> 1 <sub>B</sub> clears pre-warning alarm 0 <sub>B</sub> no-action
<b>0</b>	[31:1]	r	<b>reserved</b>

## 10.10 Interconnects

**Table 10-4 Pin Table**

Input/Output	I/O	Connected To	Description
Clock and Reset Signals			
$f_{WDT}$	I	SCU.CCU	timer clock
Timer Signals			
wdt_service	O	PORTS	service indication to external watchdog
HALTED	I	CPU	In halting mode debug. HALTED remains asserted while the core is in debug.
Service Request Connectivity			
wdt_alarm	O	SCU.GCU	pre-warning alarm
wdt_rst_req	O	SCU.RCU	reset request

## 11 Real Time Clock (RTC)

Real-time clock (RTC) is a clock that keeps track of the current time. RTCs are present in almost any electronic device which needs to keep accurate time in a digital format for clock displays and computer systems.

### 11.1 Overview

The RTC module tracks time with separate registers for hours, minutes, and seconds. The calendar registers track date, day of the week, month and year with automatic leap year correction<sup>1)</sup>. The clock of RTC is selectable via bit SCU\_CLKCR.RTCLKSEL.

The timer may remain operational during sleep or deep sleep mode.

#### 11.1.1 Features

The features of the Real Time Clock (RTC) module are:

- Real time keeping with
  - 32.768 kHz external clock
  - 32.768 kHz internal clock
- Periodic time-based interrupt
- Programmable alarm interrupt on time match
- Supports wake-up mechanism from sleep or deep sleep mode

**Table 11-1 Application Features**

Feature	Purpose/Application
Precise real time keeping	Reduced need for time adjustments
Periodic time-based interrupt	Scheduling of operations performed on precisely defined intervals
Programmable alarm interrupt on time match	Scheduling of operations performed on precisely defined times
Supports wake-up mechanism from sleep or deep sleep mode	Autonomous wakeups from sleep or deep sleep mode for system state control and maintenance routine operations

#### 11.1.2 Block Diagram

The RTC block diagram is shown in [Figure 11-1](#).

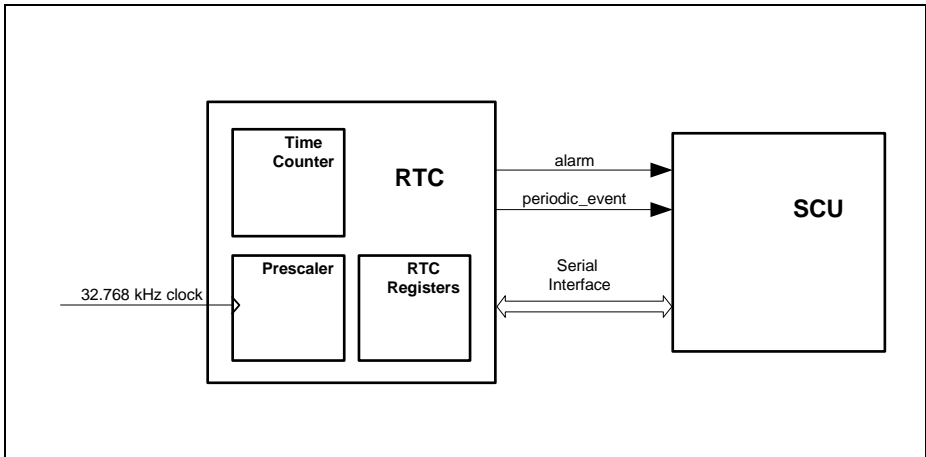
1) The automatic leap year correction is performed when the year is divisible by 4.

**Real Time Clock (RTC)**

The main building blocks of the RTC is Time Counter implementing real time counter and RTC Registers containing multi-field registers for the time counter and alarm programming register where dedicated fields represent a separate values for elapsing second, minutes, hours, days, days of week, months and years.

The RTC module is controlled directly from SCU module and shares system bus interface with other sub-modules of SCU.

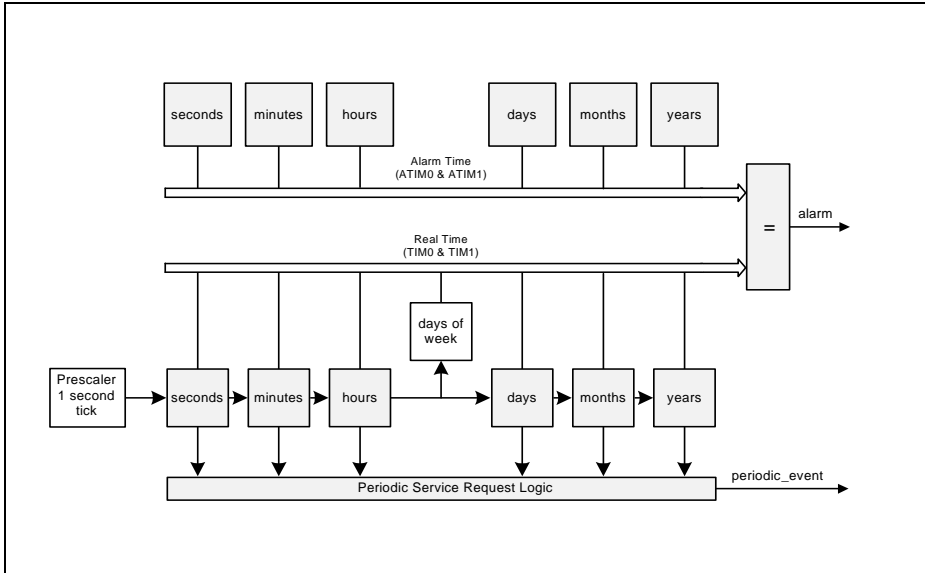
Access to the RTC registers is performed via Register Mirror updated over serial interface.



**Figure 11-1 Real Time Clock Block Diagram Structure**

## 11.2 RTC Operation

The RTC timer counts seconds, minutes, hours, days, days of week, months and years the time in separate fields (see [Figure 11-2](#)). Individual bit fields of the RTC counter can be programmed and read with software over serial interface via mirror registers in SCU module.



**Figure 11-2 Block Diagram of RTC Time Counter**

Occurrence of an internal timer event is stored in the service request raw status register **RAWSTAT**. The values of the status register **RAWSTAT** drive the outgoing service request lines **alarm** and **periodic\_event**.

### 11.3 Register Access Operations

The RTC module is a part of SCU from programming model perspective and shares register address space for configuration with other sub-modules of SCU. RTC registers are instantiated in the RTC module and mirrored in SCU. The registers get updated in both clock domains over serial interface running at 32kHz clock rate.

Any update of the registers is performed with some delay required for data to propagate to and from the mirror registers over serial interface. Accesses to the RTC registers in core domain must not block the bus interface of SCU module. For details of the register mirror and serial communication handling please refer to SCU chapter.

For consistent write to the timer registers **TIMO** and **TIM1**, the register **TIMO** has to be written before the register **TIM1**.

For consistent read-out of the timer registers **TIMO** and **TIM1**, the register **TIMO** has to be read before the register **TIM1**. The value of **TIM1** is stored in a shadow register upon each read of **TIMO** before they get copied to the mirror register in core domain.

## 11.4 Service Request Processing

The RTC generates service requests upon:

- periodic timer events
- configured alarm condition

The service requests can be processed in the core domain as regular service requests or as wake-up triggers from sleep or deep sleep mode.

### 11.4.1 Periodic Service Request

The periodic timer service request is raised whenever a non-masked field of the timer counter gets updated. Masking of the bits is performed using **MSKSR** register. Periodic Service requests can be disabled with **MSKSR**.

### 11.4.2 Timer Alarm Service Request

The alarm interrupt is triggered when **TIMO** and **TIM1** bit fields values match all corresponding bit fields values of **ATIMO**, **ATIM1** registers. The Timer Alarm Service requests can be enabled/disabled with the **MSKSR** register .

## 11.5 Debug Behavior

The RTC function can be suspended when the CPU enters HALT mode. RTC debug function is controlled with SUS bit field in **CTR** register.

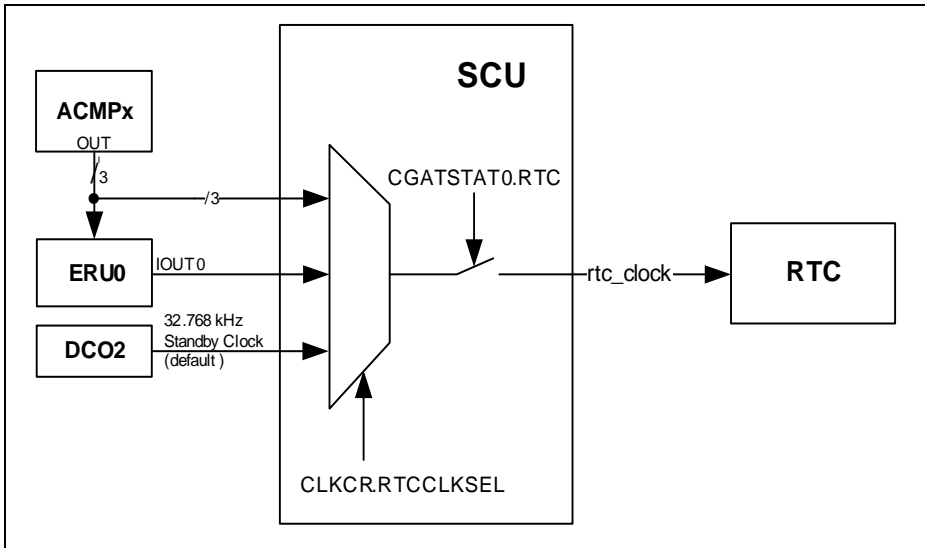
*Note: In XMC1200, bit CTR.SUS is reset to its default value by any reset. Hence, if suspend function is required during debugging, it is recommended to enable the debug suspend function in the user initialisation code. Before programming the register, the module clock has to be enabled and special care need to be handled while enabling the module clock as described in the CCU (Clock Gating Control) section of the SCU chapter.*

## 11.6 Power, Reset and Clock

RTC can be programmed to remains powered up in sleep and deep sleep mode.

The RTC module remains in reset state after initial power up until reset released.

The RTC timer is running from an internal or external 32.768 kHz clock selectable with CLKCR.RTCLKSEL control register of SCU/CCU module as shown in **Figure 11-3**.The prescaler setting of  $7FFF_H$  results in an once per second update of the RTC timer.



**Figure 11-3 RTC Clock selection**

The RTC module clock is default disabled and can be enabled via the SCU\_CGATCLR0 register.

*Note: Before changing RTC clock source via CLKCR.RTCCLKSEL, the RTC clock must be gated using bit CGATSET0.RTC.*

## 11.7 Initialization and Control Sequence

Programming model of the RTC module assumes several scenarios where different control sequences apply.

*Note:* Some of the scenarios described in this chapter require operations on system level that are not in the scope of the RTC module description, therefore for detailed information please refer to relevant chapters of this document.

### 11.7.1 Initialization & Start of Operation

Complete RTC module initialization is required upon reset. Accesses to RTC registers are performed via dedicated mirror registers (for more details please refer to SCU chapter)

- enable the clock to RTC module
  - write one to SCU\_CGATCLR0.RTC
- program RTC\_TIM0 and RTC\_TIM1 registers with current time



**Real Time Clock (RTC)**

- check SCU\_MIRRSTS to ensure that no transfer over serial interface is pending to the RTC\_TIM0 and RTC\_TIM1 registers
- write a new value to the RTC\_TIM0 and RTC\_TIM1 registers
- enable RTC module to start counting time
  - write one to RTC\_CTR.ENB

*Note: To ensure a successful transfer over serial interface, RTC\_TIM0 and RTC\_TIM1 can only be written once for each transfer. In addition, these registers must be written with a 32-bit data width. Individual bit access will not start the serial transfer operation.*

**11.7.2 Configure and Enable Periodic Event**

The RTC periodic event configuration require programming in order to enable interrupt request generation out upon a change of value in the corresponding bit fields.

- enable service request for periodic timer events in RTC module
  - set respective bit field (MPSE, MPMI, MPH0, MPDA, MPMO, MPYE) in RTC\_MSKSR register to enable the individual periodic timer events

**11.7.3 Configure and Enable Timer Event**

The RTC alarm event configuration require programming in order to enable interrupt request generation out upon compare match of values in the corresponding bit fields of TIM0 and TIM1 against ATIM0 and ATIM1 respectively.

- program compare values in individual bit fields of ATIM0 and ATIM1 in RTC module
  - check SCU\_MIRRSTS to ensure that no transfer over serial interface is pending to the RTC\_ATIM0 and RTC\_ATIM1 registers
  - write to RTC\_ATIM0 and RTC\_ATIM1 registers
- enable service request for timer alarm events in RTC module
  - set MAI bit field of RTC\_MSKSR register in order enable individual periodic timer events

*Note: To ensure a successful transfer over serial interface, RTC\_ATIM0 and RTC\_ATIM1 can only be written once for each transfer. In addition, these registers must be written in 32-bit data width. Individual bit access will not start the serial transfer operation.*

**11.8 RTC Registers****Registers Overview**

The absolute register address is calculated by adding:

Module Base Address + Offset Address

**Table 11-2 Registers Address Space**

Module	Base Address	End Address	Note
RTC	4001 0A00 <sub>H</sub>	4001 0AFF <sub>H</sub>	

**Table 11-3 Register Overview**

Short Name	Description	Offset Addr.	Access Mode		Description See
			Read	Write	
RTC Kernel Registers					
ID	ID Register	0000 <sub>H</sub>	U, PV	BE	<a href="#">Page 11-7</a>
CTR	Control Register	0004 <sub>H</sub>	U, PV	PV	<a href="#">Page 11-8</a>
RAWSTAT	Raw Service Request Register	0008 <sub>H</sub>	U, PV	BE	<a href="#">Page 11-9</a>
STSSR	Status Service Request Register	000C <sub>H</sub>	U, PV	BE	<a href="#">Page 11-10</a>
MSKSR	Mask Service Request Register	0010 <sub>H</sub>	U, PV	PV	<a href="#">Page 11-11</a>
CLRSR	Clear Service Request Register	0014 <sub>H</sub>	U, PV	PV	<a href="#">Page 11-13</a>
ATIM0	Alarm Time Register 0	0018 <sub>H</sub>	U, PV	PV	<a href="#">Page 11-14</a>
ATIM1	Alarm Time Register 1	001C <sub>H</sub>	U, PV	PV	<a href="#">Page 11-15</a>
TIM0	Time Register 0	0020 <sub>H</sub>	U, PV	PV	<a href="#">Page 11-16</a>
TIM1	Time Register 1	0024 <sub>H</sub>	U, PV	PV	<a href="#">Page 11-17</a>

### 11.8.1 Registers Description

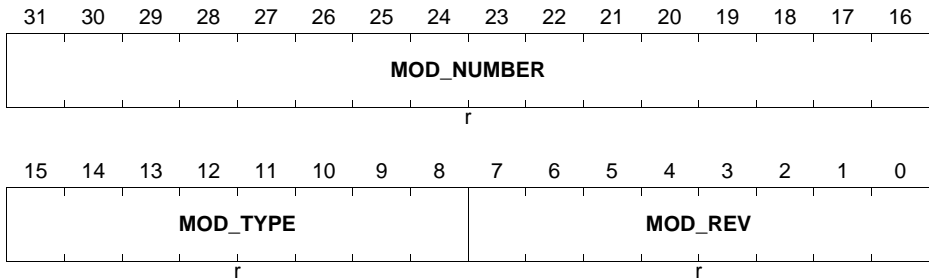
#### ID

Read-only ID register of the RTC module containing unique identification code of the RTC module.

**ID**  
**RTC Module ID Register**

(00<sub>H</sub>)

Reset Value: 00A3 C0XX<sub>H</sub>



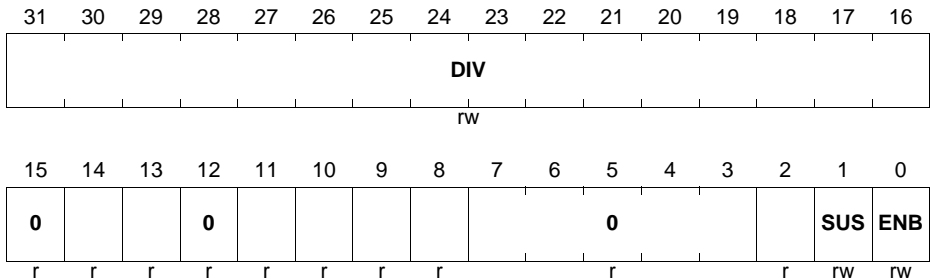
Field	Bits	Type	Description
MOD_REV	[7:0]	r	<b>Module Revision Number</b> Indicates the revision number of the implementation. The value of a module revision starts with 01 <sub>H</sub> (first revision).
MOD_TYPE	[15:8]	r	<b>Module Type</b> This bit field is fixed to C0 <sub>H</sub> .
MOD_NUMBER	[31:16]	r	<b>Module Number Value</b> This bit field defines the module identification number.

**CTR**

RTC Control Register providing control means of the operation mode of the module.

**Real Time Clock (RTC)**

**CTR**  
**RTC Control Register** (04<sub>H</sub>) **Reset Value: 7FFF 0000<sub>H</sub>**



Field	Bits	Type	Description
<b>ENB</b>	0	rw	<b>RTC Module Enable</b> 0 <sub>B</sub> disables RTC module 1 <sub>B</sub> enables RTC module
<b>SUS</b>	1	rw	<b>Debug Suspend Control</b> 0 <sub>B</sub> RTC is not stopped during halting mode debug 1 <sub>B</sub> RTC is stopped during halting mode debug
<b>DIV</b>	[31:16]	rw	<b>Divider Value</b> reload value of RTC prescaler. Clock is divided by DIV+1. 7FFF <sub>H</sub> is default value for RTC mode with 32.768 kHz crystal or external clock
<b>0</b>	[15:2]	r	<b>Reserved</b> Read as 0; should be written with 0

**RAWSTAT**

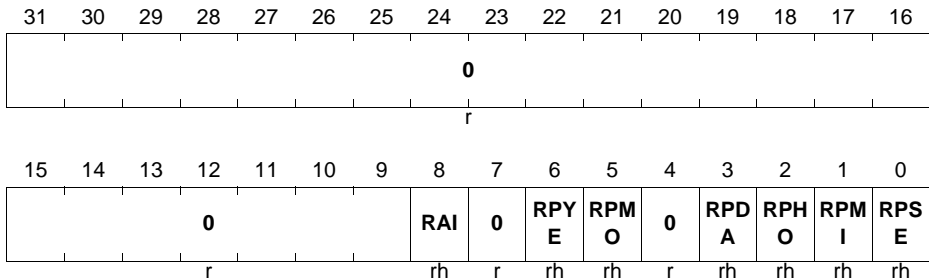
RTC Raw Service Request Register contains raw status info i.e. before status mask takes effect on generation of service requests or interrupts. This register serves debug purpose but can be also used for polling of the status without generating service requests.

**Real Time Clock (RTC)**

**RAWSTAT**

**RTC Raw Service Request Register (08<sub>H</sub>)**

**Reset Value: 0000 0000<sub>H</sub>**



Field	Bits	Type	Description
RPSE	0	rh	<b>Raw Periodic Seconds Service Request</b> Set whenever seconds count increments
RPMI	1	rh	<b>Raw Periodic Minutes Service Request</b> Set whenever minutes count increments
RPHO	2	rh	<b>Raw Periodic Hours Service Request</b> Set whenever hours count increments
RPDA	3	rh	<b>Raw Periodic Days Service Request</b> Set whenever days count increments
RPMO	5	rh	<b>Raw Periodic Months Service Request</b> Set whenever months count increments
RPYE	6	rh	<b>Raw Periodic Years Service Request</b> Set whenever years count increments
RAI	8	rh	<b>Alarm Service Request</b> Set whenever count value matches compare value
0	4, 7, [31:9]	r	<b>Reserved</b>

**STSSR**

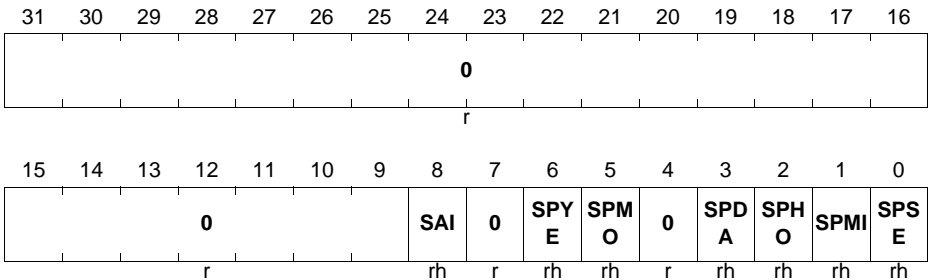
RTC Service Request Status Register contains status info reflecting status mask effect on generation of service requests or interrupts. This register needs to be accessed by software in order to determine the actual cause of an event.

**Real Time Clock (RTC)**

**STSSR**

**RTC Service Request Status Register (0C<sub>H</sub>)**

**Reset Value: 0000 0000<sub>H</sub>**



Field	Bits	Type	Description
<b>SPSE</b>	0	rh	<b>Periodic Seconds Service Request Status after masking</b>
<b>SPMI</b>	1	rh	<b>Periodic Minutes Service Request Status after masking</b>
<b>SPHO</b>	2	rh	<b>Periodic Hours Service Request Status after masking</b>
<b>SPDA</b>	3	rh	<b>Periodic Days Service Request Status after masking</b>
<b>SPMO</b>	5	rh	<b>Periodic Months Service Request Status after masking</b>
<b>SPYE</b>	6	rh	<b>Periodic Years Service Request Status after masking</b>
<b>SAI</b>	8	rh	<b>Alarm Service Request Status after masking</b>
<b>0</b>	4, 7, [31:9]	r	<b>reserved</b>

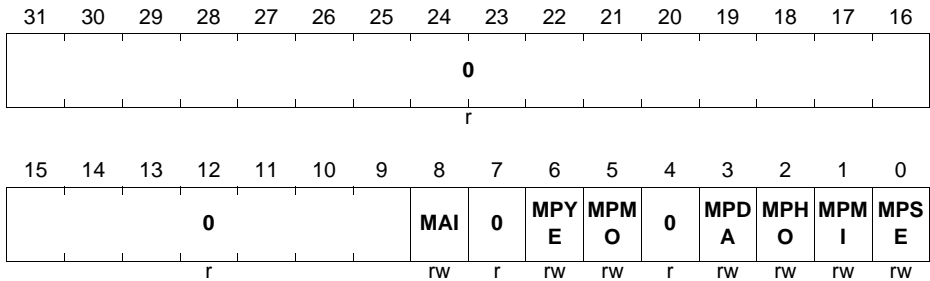
**MSKSR**

RTC Service Request Mask Register contains masking value for generation control of service requests or interrupts.

**MSKSR**

**RTC Service Request Mask Register (10<sub>H</sub>)**

**Reset Value: 0000 0000<sub>H</sub>**



Field	Bits	Type	Description
<b>MPSE</b>	0	rw	<b>Periodic Seconds Interrupt Mask</b> 0 <sub>B</sub> disable interrupt 1 <sub>B</sub> enable interrupt
<b>MPMI</b>	1	rw	<b>Periodic Minutes Interrupt Mask</b> 0 <sub>B</sub> disable interrupt 1 <sub>B</sub> enable interrupt
<b>MPHO</b>	2	rw	<b>Periodic Hours Interrupt Mask</b> 0 <sub>B</sub> disable interrupt 1 <sub>B</sub> enable interrupt
<b>MPDA</b>	3	rw	<b>Periodic Days Interrupt Mask</b> 0 <sub>B</sub> disable interrupt 1 <sub>B</sub> enable interrupt
<b>MPMO</b>	5	rw	<b>Periodic Months Interrupt Mask</b> 0 <sub>B</sub> disable interrupt 1 <sub>B</sub> enable interrupt
<b>MPYE</b>	6	rw	<b>Periodic Years Interrupt Mask</b> 0 <sub>B</sub> disable interrupt 1 <sub>B</sub> enable interrupt
<b>MAI</b>	8	rw	<b>Alarm Interrupt Mask</b> 0 <sub>B</sub> disable interrupt 1 <sub>B</sub> enable interrupt
<b>0</b>	4, 7, [31:9]	r	<b>Reserved</b>

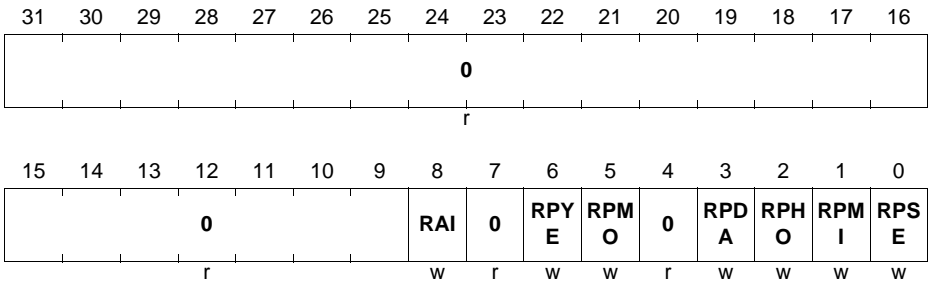
**CLRSR**

RTC Clear Service Request Register serves purpose of clearing sticky bits of **RAWSTAT** and **STSSR** registers. Write one to a bit in order to clear the status bit. Writing zero has no effect on the set nor reset bits.

**CLRSR**

**RTC Clear Service Request Register (14<sub>H</sub>)**

**Reset Value: 0000 0000<sub>H</sub>**



Field	Bits	Type	Description
RPSE	0	w	<b>Raw Periodic Seconds Interrupt Clear</b> 0 <sub>B</sub> no effect 1 <sub>B</sub> clear status bit
RPMI	1	w	<b>Raw Periodic Minutes Interrupt Clear</b> 0 <sub>B</sub> no effect 1 <sub>B</sub> clear status bit
RPHO	2	w	<b>Raw Periodic Hours Interrupt Clear</b> 0 <sub>B</sub> no effect 1 <sub>B</sub> clear status bit
RPDA	3	w	<b>Raw Periodic Days Interrupt Clear</b> 0 <sub>B</sub> no effect 1 <sub>B</sub> clear status bit
RPMO	5	w	<b>Raw Periodic Months Interrupt Clear</b> 0 <sub>B</sub> no effect 1 <sub>B</sub> clear status bit
RPYE	6	w	<b>Raw Periodic Years Interrupt Clear</b> 0 <sub>B</sub> no effect 1 <sub>B</sub> clear status bit



**Real Time Clock (RTC)**

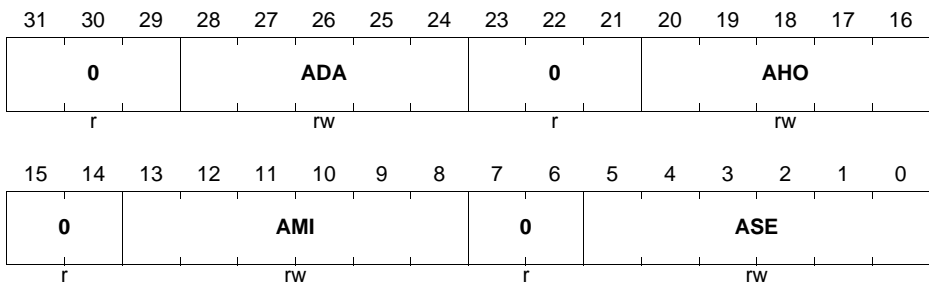
Field	Bits	Type	Description
<b>RAI</b>	8	w	<b>Raw Alarm Interrupt Clear</b> 0 <sub>B</sub> no effect 1 <sub>B</sub> clear status bit
<b>0</b>	4, 7, [31:9]	r	<b>Reserved</b>

**ATIMO**

RTC Alarm Time Register 0 serves purpose of programming single alarm time at a desired point of time reflecting comparison against **TIMO** register. The ATMO register contains portion of bit fields for seconds, minutes, hours and days. Upon attempts to write an invalid value to a bit field e.g. exceeding maximum value a default value gets programmed as described for each individual bit fields.

**ATIMO**

**RTC Alarm Time Register 0 (18<sub>H</sub>)** **Reset Value: 0000 0000<sub>H</sub>**



Field	Bits	Type	Description
<b>ASE</b>	[5:0]	rw	<b>Alarm Seconds Compare Value</b> Match of seconds timer count to this value triggers alarm seconds interrupt. Setting value equal or above 3C <sub>H</sub> results in setting the field value to 0 <sub>H</sub>
<b>AMI</b>	[13:8]	rw	<b>Alarm Minutes Compare Value</b> Match of minutes timer count to this value triggers alarm minutes interrupt. Setting value equal or above 3C <sub>H</sub> results in setting the field value to 0 <sub>H</sub>

**Real Time Clock (RTC)**

Field	Bits	Type	Description
<b>AHO</b>	[20:16]	rw	<b>Alarm Hours Compare Value</b> Match of hours timer count to this value triggers alarm hours interrupt. Setting value equal or above 18 <sub>H</sub> results in setting the field value to 0 <sub>H</sub>
<b>ADA</b>	[28:24]	rw	<b>Alarm Days Compare Value</b> Match of days timer count to this value triggers alarm days interrupt. Setting value equal or above 1F <sub>H</sub> results in setting the field value to 0 <sub>H</sub>
<b>0</b>	[7:6], [15:14], [23:21], [31:29]	r	<b>Reserved</b>

**ATIM1**

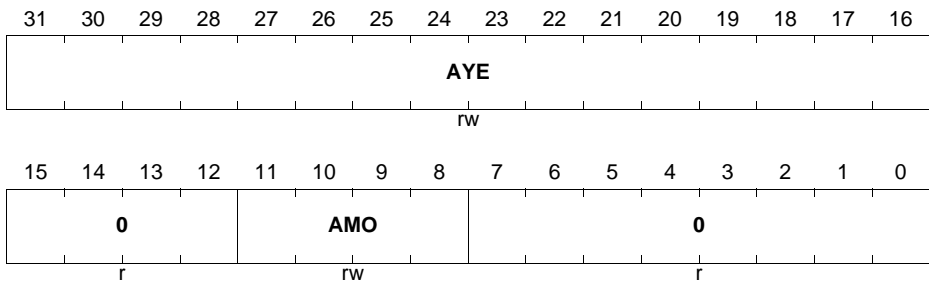
RTC Alarm Time Register 1 serves purpose of programming single alarm time at a desired point of time reflecting comparison against **TIM1** register. The ATM1 register contains portion of bit fields for months and years. Upon attempts to write an invalid value to a bit field e.g. exceeding maximum value a default value gets programmed as described for each individual bit fields.

**ATIM1**

**RTC Alarm Time Register 1**

**(1C<sub>H</sub>)**

**Reset Value: 0000 0000<sub>H</sub>**



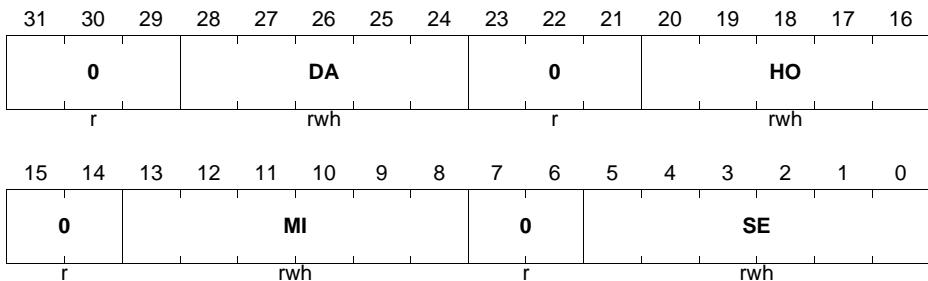
Field	Bits	Type	Description
<b>AMO</b>	[11:8]	rw	<b>Alarm Month Compare Value</b> Match of months timer count to this value triggers alarm month interrupt. Setting value equal or above the number of days of the actual month count results in setting the field value to 0 <sub>H</sub>
<b>AYE</b>	[31:16]	rw	<b>Alarm Year Compare Value</b> Match of years timer count to this value triggers alarm years interrupt.
<b>0</b>	[7:0], [15:12]	r	<b>Reserved</b>

### TIM0

RTC Time Register 0 contains current time value for seconds, minutes, hours and days. The bit fields get updated in intervals corresponding with their meaning accordingly. The register needs to be programmed to reflect actual time after initial power up and will continue counting time also while in sleep or deep sleep mode if enabled. Upon attempts to write an invalid value to a bit field e.g. exceeding maximum value a default value gets programmed as described for each individual bit fields.

### TIM0

**RTC Time Register 0 (20<sub>H</sub>)** **Reset Value: 0000 0000<sub>H</sub>**



Field	Bits	Type	Description
<b>SE</b>	[5:0]	rwh	<b>Seconds Time Value</b> Setting value equal or above $3C_H$ results in setting the field value to $0_H$ . Value can only be written, when RTC is disabled via bit CTR.ENB.
<b>MI</b>	[13:8]	rwh	<b>Minutes Time Value</b> Setting value equal or above $3C_H$ results in setting the field value to $0_H$ . Value can only be written, when RTC is disabled via bit CTR.ENB.
<b>HO</b>	[20:16]	rwh	<b>Hours Time Value</b> Setting value equal or above $18_H$ results in setting the field value to $0_H$ . Value can only be written, when RTC is disabled via bit CTR.ENB.
<b>DA</b>	[28:24]	rwh	<b>Days Time Value</b> Setting value equal or above the number of days of the actual month count results in setting the field value to $0_H$ . Value can only be written, when RTC is disabled via bit CTR.ENB. Days counter starts with value 0 for the first day of month.
<b>0</b>	[7:6], [15:14], [23:21], [31:29]	r	<b>Reserved</b>

## TIM1

RTC Time Register 1 contains current time value for days of week, months and years. The bit fields get updated in intervals corresponding with their meaning accordingly. The register needs to be programmed to reflect actual time after initial power up and will continue counting time also while in sleep or deep sleep if enabled. Upon attempts to write an invalid value to a bit field e.g. exceeding maximum value a default value gets programmed as described for each individual bit fields.

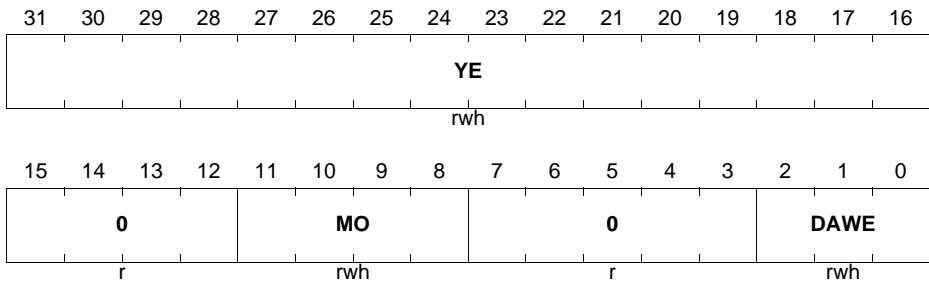
**Real Time Clock (RTC)**

**TIM1**

**RTC Time Register 1**

**(24<sub>H</sub>)**

**Reset Value: 0000 0000<sub>H</sub>**



Field	Bits	Type	Description
<b>DAWE</b>	[2:0]	rwh	<b>Days of Week Time Value</b> Setting value above 6 <sub>H</sub> results in setting the field value to 0 <sub>H</sub> . Value can only be written, when RTC is disabled via bit CTR.ENB. Days counter starts with value 0 for the first day of week.
<b>MO</b>	[11:8]	rwh	<b>Month Time Value</b> Setting value equal or above C <sub>H</sub> results in setting the field value to 0 <sub>H</sub> . Value can only be written, when RTC is disabled via bit CTR.ENB. Months counter starts with value 0 for the first month of year.
<b>YE</b>	[31:16]	rwh	<b>Year Time Value</b> Value can only be written, when RTC is disabled.
<b>0</b>	[7:3], [15:12]	r	<b>Reserved</b>

**11.9 Interconnects**

**Table 11-4 Pin Connections**

Input/Output	I/O	Connected To	Description
Clock Signals			
$f_{RTC}$	I	SCU.CCU	32.768 kHz clock selected
Debug Signals			
HALTED	I	CPU	Indicates the processor is in debug state and halted
Service Request Connectivity			
periodic_event	O	SCU.GCU	Timer periodic service request
alarm	O	SCU.GCU	Alarm service request

## 12 System Control Unit (SCU)

The SCU is the SoC power, reset and a clock manager with additional responsibility of providing system stability protection and other auxiliary functions.

### 12.1 Overview

The functionality of the SCU described in this chapter is organized in the following sub-chapters, representing different aspects of system control:

- Miscellaneous control functions, GCU [Chapter 12.2](#)
- Power control, PCU [Chapter 12.3](#)
- Reset operation, RCU [Chapter 12.4](#)
- Clock Control, CCU [Chapter 12.5](#)

#### 12.1.1 Features

The following features are provided for monitoring and controlling the system:

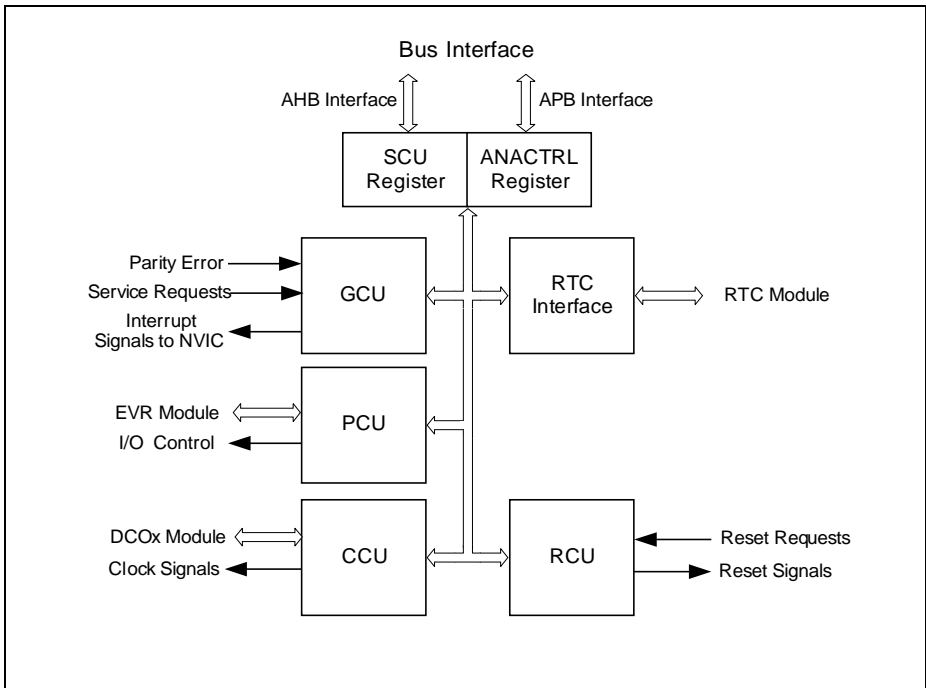
- General Control
  - Start-up Software (SSW) and Boot Mode Support
  - Memory Content Protection
  - Interrupt Handling
- Power control
  - On-chip core supply generation via EVR
  - Power Validation
  - Supply Watchdog
  - Voltage Monitoring
  - Load Change Handling
- Reset Control
  - Reset assertion on various reset request sources
  - System Reset Generation
  - Inspection of reset sources after reset
- Clock Control
  - Clock Generation
  - Clock Supervision
  - Individual Peripheral Clock Gating
  - Clock Blanking Support

### 12.1.2 Block Diagram

Figure 12-1 shows the following sub-units:

- Power Control Unit (PCU)
- Reset Control Unit (RCU)
- Clock Control Unit (CCU)
- General Control Unit (GCU)

All the SFRs in SCU module are accessible via the AHB and the 16-bit APB bus interface as shown in Figure 12-1. The APB bus interface is used to access the group of SFR called ANACTRL register. These registers are used to configure the analog modules in the system, namely, the embedded voltage regulator (EVR) and the digitally controlled oscillators (DCO1 and DCO2). The other group of SFR called SCU register are accessible via the AHB bus interface.



**Figure 12-1 SCU Block Diagram**



### **Interface of General Control Unit**

The General Control Unit GCU has a memory fault interface to the memory validation logic of each on-chip SRAM and the Flash to receive memory fault events, as parity errors.

### **Interface of Power Control Unit**

The Power Control Unit PCU has an interface to the Embedded Voltage Regulator (EVR) and an interface to the CCU module. The PCU related signals are described in more detail in [Chapter 12.3](#).

### **Interface of Reset Control Unit**

The Reset Control Unit RCU has an interface to the Embedded Voltage Regulator (EVR). The RCU receives the power-on reset and the brownout reset information from the EVR. Reset requests are coming to the unit from the watchdog, the CPU, the GCU and the clock control unit (CCU). The RCU is providing the reset signals to all other units of the chip in the core power domain. The RCU related signals are described in more detail in [Chapter 12.4](#).

### **Interface of Clock Control Unit**

The Clock Control Unit (CCU) receives the clock source from the on-chip Digitally Controlled Oscillator (DCO). The CCU provides the clock signals to all other units of the chip.

### **Interface of RTC**

Access to the RTC module is served over a serial interface. The interface provides mirror registers updated via the serial interface to the RTC module registers. Update of the mirror registers over the serial is controlled using **MIRRSTS** registers. End of update can also trigger service requests via **SRRAW** register. Refresh of the registers in the register mirror are performed continuously, as fast as possible in order to instantly reflect any register state change on both sides.

The RTC module functionality is described in separate RTC chapter.

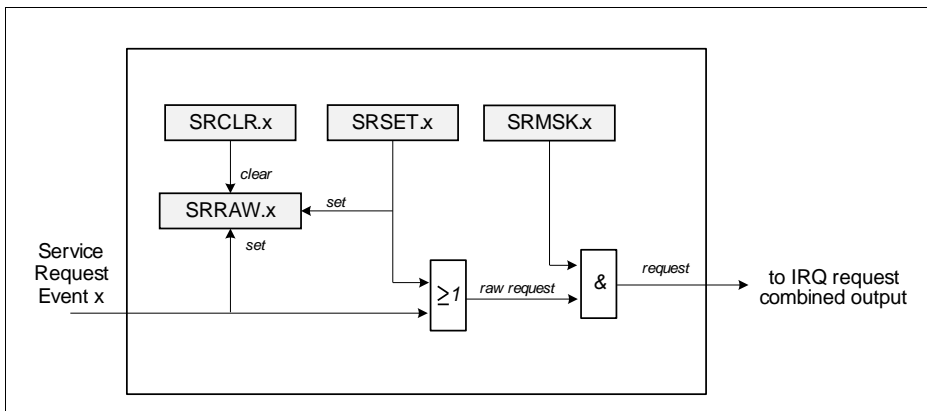
## 12.2 Miscellaneous Control Functions (GCU)

System Control implements system management functions accessible via GCU registers. General system control including various auxiliary function is performed in the General Control Unit (GCU).

### 12.2.1 Service Requests Handling

Service request events listed in [Table 12-1](#) can result in assertion of an interrupt. Please refer to [SRMSK](#) a register description.

The interrupt structure is shown in [Figure 12-2](#). The interrupt request or the corresponding interrupt set bit (in register [SRSET](#)) can trigger the interrupt generation at the selected interrupt node  $x$ . The service request pulse is generated independently from the interrupt flag in register [SRRAW](#). The interrupt flag can be cleared by software by writing to the corresponding bit in register [SRCLR](#).



**Figure 12-2 Service Request Handling**

The flag in register [SRRAW](#) can be cleared by software by writing to the corresponding bit in register [SRCLR](#). All trap requests are combined to one common line and connected to a regular interrupt node of NVIC.

*Note: When servicing an SCU service request, make sure that all related request flags are cleared after the identified request has been handled.*

#### 12.2.1.1 Service Request Sources

The SCU supports service request sources listed in [Table 12-1](#) and reflected in the [SRRAW](#), [SRMSK](#), [SRCLR](#) and [SRSET](#) registers. The events that trigger these service

**System Control Unit (SCU)**

requests are described in the respective module chapters or in the various sections within SCU.

**Table 12-1 Service Requests**

<b>Modules</b>	<b>Service Request Name</b>	<b>Service Request Short Name</b>	<b>SCU.SRx</b>
NVM	Flash Double Bit ECC Event	FLECC2I	SR0
	Flash Operation Complete Event	FLCMLPTI	
	16kbytes SRAM Parity Error Event	PESRAMI	
	USIC0 SRAM Parity Error Event	PEU0I	
SCU:CCU	Loss of Clock Event	LOCI	SR1
	Standby Clock Failure Event	SBYCLKFI	
SCU:PCU	VDDP Pre-warning Event	VDDPI	
	VDROP Event	VDROPI	
	VCLIP Event	VCLIPI	
SCU:GCU	Temperature Sensor Done Event	TSE_DONE	
	Temperature Sensor Compare High Event	TSE_HIGH	
	Temperature Sensor Compare Low Event	TSE_LOW	
WDT	WDT pre-warning	PRWARN	
RTC	RTC Periodic Event	PI	
	RTC Alarm	AI	
	RTC CTR Mirror Register Updated	RTC_CTR	
	RTC ATIM0 Mirror Register Updated	RTC_ATIM0	
	RTC ATIM1 Mirror Register Updated	RTC_ATIM1	
	RTC TIM0 Mirror Register Updated	RTC_TIM0	
	RTC TIM1 Mirror Register Updated	RTC_TIM1	
ORC	Out of Range Comparator Event	ORCxI [x = 0 - 7]	SR2
ACMP	Analog Comparator Event	ACMP0I, ACMP1I, ACMP2I	

### 12.2.2 SRAM Memory Content Protection

For supervising the content of the on-chip SRAM memories, the following mechanism is provided:

All on-chip SRAMs provide protection of content via parity checking. The parity logic generates additional parity bits which are stored along with each data word at a write operation. A read operation implies checking of the previous stored parity information.

An occurrence of a parity error is observable at the **SRRAW** status register. It is configurable via **SRMSK** whether a memory error should trigger an interrupt. It can also trigger a system reset when **RSTCON.SPERSTEN** or **RSTCON.U0PERSTEN** is set to 1.

A parity control software test, such as to support in-system testing to fulfill Class B requirements, can be enabled with bit **PMTSR.MTENS** for the 16 kbytes SRAM memory individually. Once this bit is set, an inverted parity bit is generated during a write operation. When a read operation is performed on this SRAM address, a parity error shall be detected.

*Note: Test software should be located in a different memory space.*

### 12.2.3 Summary of ID

This section describes the various ID in XMC1200.

#### Module Identification

The module identification register indicates the function and the design step of each peripherals. Register **SCU\_ID** is used for SCU module.

#### System ROM Table ID

The PID values in the system ROM table are defined in the **Table 12-2**. The XMC1200 system ROM table is located at F000 0000<sub>H</sub>. Cortex-M0 ROM table is described in the debug chapter.

**Table 12-2 PID Values of XMC1200 System ROM Table**

Name	Offset	Reference	Values
PID0	FE0 <sub>H</sub>	XMC1200 Part Number [7:0]	ED <sub>H</sub>
PID1	FE4 <sub>H</sub>	bits [7:4] JEP106 ID code [3:0] bits [3:0] XMC1200 Part Number [11:8]	11 <sub>H</sub>
PID2	FE8 <sub>H</sub>	bits [7:4] XMC1200 Revision bit [3] == 1: JEDEC assigned ID fields bits [2:0] JEP106 ID code [6:4]	1C <sub>H</sub>

**Table 12-2 PID Values of XMC1200 System ROM Table**

<b>Name</b>	<b>Offset</b>	<b>Reference</b>	<b>Values</b>
PID3	FEC <sub>H</sub>	bits [7:4] RevAnd, minor revision field bits [3:0] if non-zero indicate a customer-modified block	00 <sub>H</sub>
PID4	FD0 <sub>H</sub>	bits [7:4] 4KB count bits [3:0] JEP106 continuation code	00 <sub>H</sub>

### Chip Identification Number

The chip identification number is a 8 word length number. It consists of the values in register DBGROMID, IDCHIP, register PAU\_FLSIZE, register PAU\_RAM0SIZE and register PAU\_AVAILn(n=0-2) respectively. This number is for easy identification of product variants information of the device, example, package type, the temperature profile, flash size, RAM size and the peripheral availability.

## 12.3 Power Management (PCU)

Power management control is performed in the Power Control Unit (PCU).

### 12.3.1 Functional Description

The XMC1200 is running from a single external power supply of 1.8 - 5.5V ( $V_{DDP}$ ). The main supply voltage is supervised by a supply watchdog.

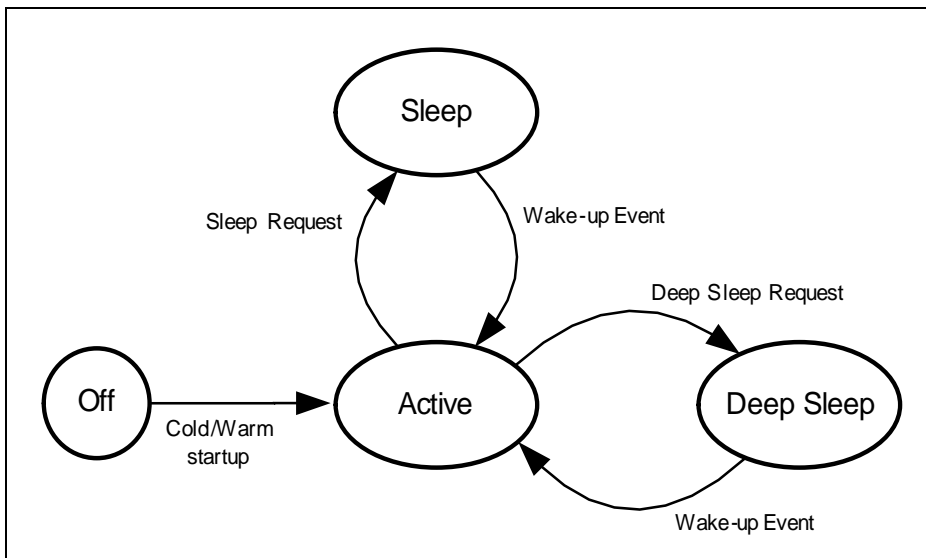
The I/Os is running directly from the external supply voltage. The core voltage ( $V_{DDC}$ ) is generated by an on-chip Embedded Voltage Regulator (EVR). The safe voltage range of the core voltage is supervised by a power validation circuit, which is part of the EVR.

### 12.3.2 System States

The system has the following general system states:

- Off
- Active
- Sleep
- Deep-Sleep

**Figure 12-3** shows the state diagram and the transitions between the states.



**Figure 12-3 System States Diagram**

### Active State

The active state is the normal operation state. The system is fully powered. The CPU is usually running from a high-speed clock. Depending on the application, the system clock might be slowed down. Unused peripherals might be stopped by gating the clock to these peripherals.

### Sleep State

The sleep state of the system corresponds to the sleep state of the CPU. The state is entered via WFI or WFE instruction of the CPU. In this state, the clock to the CPU is stopped. To save power, the clock of the peripherals that are not needed during sleep state can be gated by register **CGATSET0** before entering sleep state.

The Flash can be put into shutdown mode during active state to achieve a further power reduction before entering sleep state via bit NVMCONF.NVM\_ON. However, user code would have to be executed in SRAM before entering sleep state and after waking up from sleep state.

To avoid the switching of code execution to SRAM due to the shutdown of flash, register **PWRSVCR** can be used. When FPD bit is set, flash is shutdown only when the device has entered sleep state. The shut down operation is performed after the core has executed WFI/WFE instruction. After a wake-up event is detected, the system will resumed to the previous state i.e. the flash is operable again before the CPU can continue to fetch and execute the code. In this case, user code can be executed in Flash and no switching to SRAM is needed. In his approach, the wake-up time is longer because of the time needed for flash to reach the active state.

Peripherals can continue to operate unaffected and eventually generate an event to wake-up the CPU. In User with Debug mode (UMD) or User with Debug mode and HAR (UMHAR), a Debug HALT request is also able to wake-up the CPU. Any accordingly configured interrupt will bring the CPU back to operation via the NVIC or the M0 debug system.

### Deep-Sleep State

The deep-sleep state is entered on the same mechanism as the sleep state with the addition that user code has enabled the deep-sleep state in system control register. This state is similar to sleep state, except that in deep-sleep state, the PCLK and MCLK will be switched to a slow standby clock and DCO1 will be put into power-down mode.

The analog comparator could also be kept active during deep-sleep state. It can be switched to low power mode to save power.

The shutting down of flash via NVMCONF.NVM\_ON or PWRSVCR.FPD as explained in above section is applicable for deep-sleep mode.

Peripherals that continue to operate will run using the slow standby clock and can eventually generate an event to wake-up the CPU. In User with Debug mode (UMD) or

**System Control Unit (SCU)**

User with Debug mode and HAR (UMHAR), a Debug HALT request is also able to wake-up the CPU. Any accordingly configured interrupt will bring the CPU back to operation via the NVIC or the M0 debug system. The clock system is restored to the previous configuration for active state upon wake-up. Peripherals that are active will run with restored clock configuration.

The SRAM content is preserved in the deep-sleep state.

*Note: It is recommended to slow down the PCLK and MCLK before entering deep sleep mode to prevent a sudden load change that could cause a brownout reset.*

**12.3.3 Embedded Voltage Regulator (EVR)**

The EVR generates the core voltage  $V_{DDC}$  out of the external supplied voltage  $V_{DDP}$ . The EVR provides 2 supply monitoring detectors for the input voltage  $V_{DDP}$ . The generated core voltage  $V_{DDC}$  is monitored by a power validation circuit (PV).

**12.3.4 Power-on Reset**

The EVR starts operation as soon as  $V_{DDP}$  is above defined minimum level. It releases the reset, when the external voltage  $V_{DDP}$  and the generated voltage  $V_{DDC}$  are above the reset thresholds and reaching the nominal values.

**12.3.5 Power Validation**

A power validation circuit monitors the internal core supply voltage,  $V_{DDC}$ . It monitors that the core voltage is above the voltage threshold  $V_{DDCBO}$  which guarantees safe operation. Whenever the voltage falls below the threshold level, a brownout reset is generated.

**12.3.6 Supply Voltage Monitoring**

There are 2 detectors, namely, External voltage detector (VDEL) and External brownout detector (BDE) in the EVR that are used to monitor the  $V_{DDP}$ .

VDEL detector compares the supply voltage against a pre-warning threshold voltage. The threshold level is programmable via register ANAVDEL.VDEL\_SELECT. An interrupt if enabled, will be triggered if a level below this threshold is detected and the flag, VDDPI, in SRRAW register bit is set. An indication bit, VDESR.VDDPPW, shows the output of the detector.

BDE detector is used to trigger a brownout reset when the  $V_{DDP}$  supply voltage drops below the defined threshold. Similarly, it is also used to ensure a proper startup when the  $V_{DDP}$  is above the defined threshold during the power-up phase.

The Data Sheet defines the nominal value and applied hysteresis



### 12.3.7 $V_{DDC}$ Response During Load Change

In XMC1200, the core voltage level,  $V_{DDC}$ , drops below the typical threshold when there is an increase in the load and rises when there is a decrease in the load. 2 detectors, VDROP and VCLIP detectors are used to monitor the lower limits and the upper limits of the core voltage level respectively (detectors details are described in the next section). A VDROP event happens when VDDC drops below the VDROP threshold voltage. A VCLIP event happens when VDDC rises above the VCLIP threshold voltage. Each of these events can trigger its dedicated interrupt if enabled via SRMSK register and the event status can be monitored via SRRAW register.

In XMC1200, the following scenarios may trigger a VDROP/VCLIP event due to load change:

- Changing the MCLK and PCLK frequency via CLKCR register
- Enabling/Gating the peripheral clock via the CGATSET0/CGATCLR0 registers

When a sudden load change happens ( $< 4 \times \text{baseload}$  or  $> 0.25 \times \text{baseload}$ )(TBC), regardless of an increase or decrease in load, the EVR needs time (15 usec) to regulate the core voltage back to a stable nominal voltage. During this period of time, the system is expected to maintain in the current load and no load change is allowed. Status bit VDDC2LOW and VDDC2HIGH in CRCLK register are used to indicate whether the voltage is stable.

*Note: It is not recommended to increase the load more than 4 times of the baseload or decrease the load to less than 0.25 times of the baseload. If a bigger than the specified load change is required, the recommendation is to change the load in steps that each step is within the limits. For example, a final load of 16mA from the current baseload of 1mA needs at least 2 steps. A step from 1mA to 4mA followed by another step from 4mA to 16mA*

The VDDC2LOW and VDDC2HIGH status bit is generated by a 10-bit counter using DCO1, 64MHz clock as the clock input. It is implemented to count the 16 usec (default) that is needed to have a stable  $V_{DDC}$  after a VDROP or VCLIP event happens. The length of this counter can be changed depending on the amount of load change via bit CLKCR.CNTADJ. The larger is the load change, the more is the time that user need to wait for a stable clock. Refer to datasheet for a guideline of the current consumption of each modules.

Using the example above, after programming some configuration that causes a change in load from 1mA to 4mA, user can poll for VDDC2LOW (CNTADJ=3FF<sub>H</sub>) to ensure the 16 usec(max) needed to regulate EVR. After VDDC2LOW is set to 0, another load change from 4mA to 16mA can be performed and the cycle repeats for each step of load change.

During a VDROP event, clock blanking happens and the detail description is documented in **“Clock Blanking” on Page 12-17**. CPU clock and peripheral clocks continue to run during VCLIP event.

---

**System Control Unit (SCU)**

*Note: When overflow event happens while the VDROP=1 (time to overflow based on the CNTADJ value is shorter than the time the device stays in a vdrop event), the 10-bit counter will automatically be restarted with the CNTADJ value.*

*Note: VDROP and VCLIP detectors are disabled during deep sleep mode.*

### **12.3.8 Flash Power Control**

The Flash module can be switched off to reduce static power. In sleep or deep-sleep state, it is dependent on the setting of register **PWRSVCR** whether the Flash module will be put to sleep or not in this state. The user has to evaluate the reduced leakage current against the longer startup time. In addition, the Flash can also be put to sleep using **NVMCONF.NVM\_ON** before entering these power save modes.

## 12.4 Reset Control (RCU)

Reset Control Unit performs control of all reset related functionality including:

- Reset assertion on various reset request sources
- Inspection of reset sources after reset
- Selective reset of peripheral

### 12.4.1 Functional Description

The XMC1200 has the following reset types for the system:

- Master Reset,  $\overline{\text{MRESET}}$
- System Reset,  $\overline{\text{SYSRESET}}$

#### Master Reset, $\overline{\text{MRESET}}$

Master reset is triggered by:

- Power-on reset (PORST)
- $V_{\text{DDP}}$  or  $V_{\text{DDC}}$  undervoltage reset (also known as brownout reset)
- SW master reset via setting bit RSTCON.MRSTEN to 1

A complete reset to the device is executed by a master reset. Master reset is triggered by a power-on reset upon power-up. Whenever the supply  $V_{\text{DDP}}$  is ramped-up and crossing the  $V_{\text{DDP}}$  and  $V_{\text{DDC}}$  voltage threshold, the power-on reset is released. A power-on reset (also known as brown-out reset) is asserted again whenever the  $V_{\text{DDP}}$  voltage or the  $V_{\text{DDC}}$  voltage falls below reset thresholds. In additional, a master reset can be triggered by setting bit RSTCON.MRSTEN.

The sources that trigger a master reset also triggers a system reset  $\overline{\text{SYSRESET}}$ .

#### System Reset, $\overline{\text{SYSRESET}}$

System reset is triggered by:

- SW reset via Cortex M0 Application Interrupt and Reset Control Register (AIRCR)
- Lockup signal from Cortex M0 when enabled at RCU
- Watchdog reset
- Memory parity error when enabled
- Flash ECC double bit error when enabled
- Loss of clock when enabled
- sources that trigger a master reset

A system reset affects almost all logics. The only exceptions are RCU registers and Debug system when debug probe is present. The reset gets extended to the length defined by implementation requirements.

The debug system is reset by System Reset in normal operation mode when debug probe is not present. When debug probe is present, System Reset must not affect the Debug system.

### 12.4.2 Reset Status

The EVR provides the cause of a power on reset to the RCU. The reset cause can be inspected after resuming operation by reading register **RSTSTAT**. This register also indicates the source of event that causes the triggering of a system reset.

All registers of the RCU undergo reset only by a master reset except for RSTSTAT and RSTCON register. RSTSTAT register is only reset by a power-on reset and RSTCON is reset by any reset type.

*Note: Clearing of the reset status via register bit **RSTCLR.RSCLR** is strongly recommended to ensure a clear indication of the cause of next reset.*

**Table 12-3** shows an overview of the reset signals their source and effects on the various parts of the system.

**Table 12-3 Reset Overview**

Module/Function	Power-on Reset	Master Reset by SW bit	System Reset
CPU Core	yes	yes	yes
SCU	yes	yes	yes, except reset indication bit
Peripherals	yes	yes	yes
Debug System	yes	yes	see footnote <sup>1)2)</sup>
Port Control	yes	yes	yes
SRAM	Affected,unreliable	Not affected	Not affected
Flash	yes	yes	yes
EVR	yes	no <sup>3)</sup>	no
Clock System	yes	yes	yes

1) Debug system will be reset only if debug probe is not present.

2) Access to debug interface is disabled after every reset even when debug probe is present. See Warm Reset section of Debug System chapter for more details.

3) The supply to EVR will not be affected and hence a complete reset to EVR is not possible. However, it will be partially affected by the reset in the ANACTRL module.

## 12.5 Clock Control (CCU)

### 12.5.1 Features

The clock control unit CCU has the following functionality:

- Dedicated RTC and standby clock
- Clock Supervisory
  - Oscillator watchdog
- Wide range of frequency scaling of system frequencies
- Individual peripheral clock gating

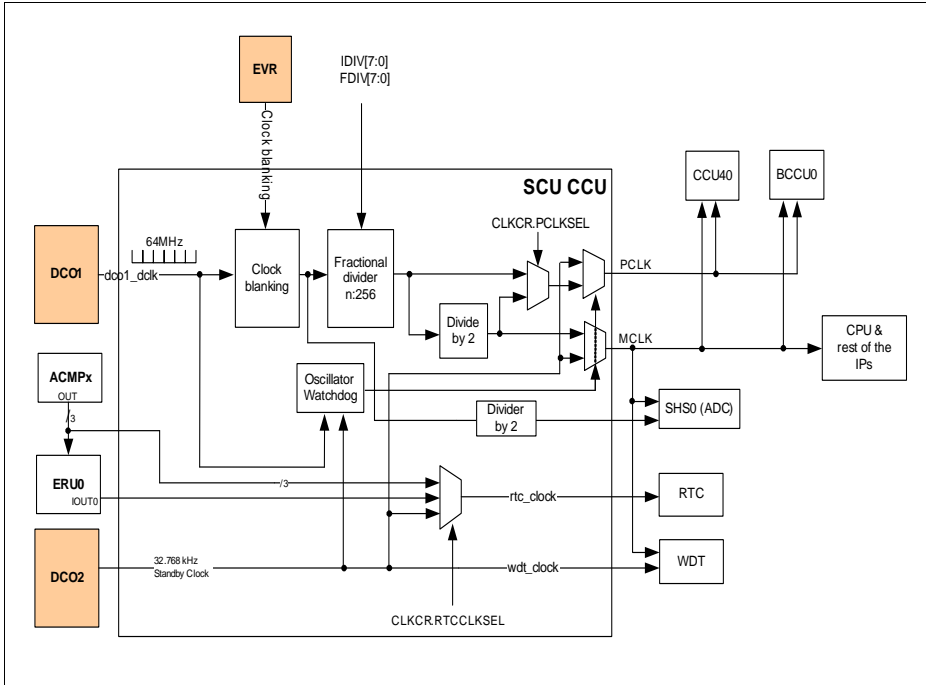
### 12.5.2 Clock System and Control

**Figure 12-4** shows the block diagram of the clock system in XMC1200. It consists of two oscillator (DCO1<sup>1</sup>) and DCO2) and a clock control unit (CCU). DCO1 has a clock output, dco1\_dclk running at 64MHz. DCO2 is used to generate the standby clock running at 32.768kHz. The main clock, MCLK, and fast peripheral clock, PCLK, are generated from dco1\_dclk. PCLK is running in either the same frequency as MCLK or double the frequency of MCLK. It is selectable via CLKCR.PCLKSEL.

**Figure 12-4** shows the list of peripherals that are running in the PCLK domain. The rest of the peripherals except RTC and WDT are clocked by MCLK which is the same as the core and bus system. RTC and WDT is running at a frequency of 32.768kHz from the standby clock which is asynchronous to the MCLK and PCLK clock.

---

1) The accuracy of the DCO1 clock output can be improved by calibrating it based on the die temperature given by the temperature sensor. Refer to [Section 12.5.4](#) for detailed description.



**Figure 12-4 Clock System Block Diagram**

*Note: SHS(ADC) clock will not switched to standby clock source when there is a loss of clock event.*

*Note: RTC\_extclk are further described in RTC chapter .*

### Fractional Divider

The frequency of MCLK and PCLK are programmable through a fractional divider. PCLK has a range of frequency from 125kHz to 64MHz and MCLK has a range from 125kHz to 32MHz.

The following formula calculate the MCLK clock frequency.

(12.1)

$$\left( \text{MCLK} = \frac{\text{dco\_dclk}}{(2) \times \left( \text{IDIV} + \frac{\text{FDIV}}{256} \right)} \right) \text{ for IDIV} > 0$$

The following formula calculate the PCLK clock frequency when CLKCR.PCLKSEL is set to 1 and it is double the frequency of MCLK.

(12.2)

$$\left( \text{PCLK} = \frac{\text{dco\_dclk}}{\left( \text{IDIV} + \frac{\text{FDIV}}{256} \right)} \right) \text{ for IDIV} > 0$$

IDIV represents an unsigned 8-bit integer from the bit field CLKCR.IDIV and FDIV/256 defines the fractional divider selection in CLKCR.FDIV. Changing of the MCLK and PCLK can be done within 2 clock cycles. While changing the frequency of MCLK clock and PCLK clock, it is recommended to disable all interrupts to prevent any access to flash that may results in an unsuccessful flash operation.

*Note: Changing the MCLK and PCLK frequency may result in a load change that causes clock blanking to happen. Refer to [Clock Blanking](#) and [VDDC Response During Load Change](#) for more details.*

### Clock Blanking

To prevent a brown-out reset in case of a sudden positive load change, the clock blanking circuitry is used. It freed the clock input to the fractional divider to regulate the

**System Control Unit (SCU)**

load change. The clock blanking only causes a small jitter if it is considered over a longer time period.

The clock blanking is activated when  $V_{DDC}$  is detected to be below the VDROP threshold. Once the  $V_{DDC}$  is above this threshold, the enabled clocking is resume. This voltage drop detector is part of the EVR and it is activated by default upon any reset.

To monitor clock blanking activities, user can enable interrupt but can only enter ISR after the clock resume.

In addition to the use of clock blanking function to prevent a brown-out reset, the system is also expected to maintain in the current load and no further load change is allowed for 16 usec (max). Detail description of the core voltage behaviors during load change are described in **“VDDC Response During Load Change” on Page 12-11**.

As described in **“VDDC Response During Load Change” on Page 12-11**, the status bit CLKCR.VDDC2LOW is used to indicate to user that the core voltage,  $V_{DDC}$ , is below the nominal voltage and EVR is in the process of regulating it. During this period, the clock could be also not running in the selected speed and it is recommended to poll this bit before continuing with any large change to the current load.

*Note: It is recommended to slow down the PCLK and MCLK before entering deep sleep mode to prevent a sudden load change that could cause a brownout reset when entering .*

**12.5.2.1 Oscillator Watchdog**

The oscillator watchdog (OWD) monitors the DCO1 clock frequency using the standby clock as the reference clock. It can be disabled via OSCCSR.OWDEN. By setting bit OSCCSR.OWDRES<sup>1)</sup>, the detection for DCO1 clock frequency can be restarted. The detection status output is only valid after some cycles of the standby clock frequency. When the OWD is disabled, the detection status will be reset and no detection is possible.

If the OWD is enabled before entering deep sleep mode, it will be disabled automatically by hardware when it enters deep sleep mode and re-enabled again after exiting deep sleep mode. The detection is reset and restarted after device wake-up from deep sleep mode.

**12.5.2.2 Loss of Clock Detection and Recovery**

Loss of clock happens when the oscillator watchdog (OWD) detects a DCO1 frequency that is less than 50 MHz or more than 68.5 MHz during normal operation. In this case,

---

1) It is recommended to clear the status bit SRRAW.LOCI and SRRAW.SBYCLKFI before restarting the detection.



## System Control Unit (SCU)

an interrupt will be generated if it is enabled. Concurrently, the oscillator status flag, OSCCSR.OSC2L or OSCCSR.OSC2H, is set to 1 and the system clock will be provided by the standby clock of 32.768kHz. Emergency routines can be executed to safely shut down the system. Beside triggering an interrupt when the loss of clock happens, a system reset can also be triggered if it is enabled by **RSTCON.LOCRSTEN**.

*Note: Switching to standby clock during loss of clock event happens only if DCO2 is still running (>0MHz). Bit **SRRAW.SBYCLKFI** indicates the fail status of the standby clock.*

The XMC1200 remains in this loss of clock state until the next reset or after a successful clock recovery has been performed. A clock recovery could be carried out by restarting the detection by setting bit OSCCSR.OWDRES. Upon detecting a stable oscillator frequency of more than 50 MHz and lower than 68.5MHz, OSC2L and OSC2H will be set to 0 and the MCLK will switched automatically to the DCO1 clock source.

### 12.5.2.3 Standby Clock Failure

The standby clock failure event happens when the OWD detects a failure in standby clock where the clock stops running (~0kHz). Bit SRRAW.SBYCLKFI is set to 1 and trigger an interrupt via SCU\_SR1 service request if the interrupt is enabled in register SRMSK.

### 12.5.2.4 Startup Control for System Clock

When the XMC1200 starts up after reset, system frequency is provided by the DCO1 oscillator. After reset, CPU runs in 8MHz, default frequency. User can change the clock frequency that is used to execute the SSW by defining it in the flash memory location 1000 1010<sub>H</sub>. Refer to Boot and Startup chapter for more details.

### 12.5.3 Clock Gating Control

The clock to peripherals can be individually gated and parts of the system can be stopped by registers **CGATSET0**. After a master reset, only core, memories, SCU and PORT peripheral are not clock gated. The rest of the peripherals are default clock gated. User can select the clock of individual modules to be enabled by SSW after reset by defining it in the flash memory location 1000 1014<sub>H</sub>. Refer to Boot and Startup chapter for more details.

### Load change during module clock enabling or gating

Enabling or gating the clock to peripherals could result in a load change that could cause clock blanking to happen. In addition, a load change of more than 4 times the current load would required the system to maintain in the current load and no further load change

is allowed for 16 usec (max). See [VDDC Response During Load Change](#) for more details.

### Module clock gating in Sleep and Deep-Sleep modes

It is recommended to gate the clock using registers **CGATSET0** for module that is not needed during sleep mode or deep-sleep mode. These modules must be disabled before entering sleep or deep-sleep mode. In addition, the PCLK and MCLK will be switched to a slow standby clock and DCO1 will be put into power-down mode in deep-sleep mode.

### 12.5.4 Calibrating DCO based on Temperature

In XMC1200, DCO1 clock frequency can be calibrated during runtime to achieve a better accuracy. Based on the measured temperature using the on-chip temperature sensor, an offset value can be obtained using the formulae as shown below :

$$\text{OFFSET} = \text{tbd} [\text{steps}]$$

There are 2 constants: DCO\_ADJL\_RT and DCO\_ADJL\_HT in the formulae and these values are stored in flash configuration page shown in [Table 12-4](#).

**Table 12-4 DCO calibration data in Flash CS0**

Address	Length	Function
DCO calibration data:		
1000'0F40 <sub>H</sub>	2 B	DCO_ADJL_RT Frequency Low Adjustment value measured at room temperature (5 LSbits)
1000'0F42 <sub>H</sub>	2 B	DCO_ADJL_HT Frequency Low Adjustment value measured at high temperature (5 LSbits)

Input the offset value to register bit **ANAOFFSET.ADJL\_OFFSET** to start the DCO1 calibration. This bit field is bit protected. DCO1 will take about 5 usec(max) for clock to be adjusted to the new frequency. It is recommended to adjust the DCO1 at every steps of tbd °C.

### 12.6 Service Request Generation

The SCU module provides 3 service request outputs SR[2:0]. SR0 is for system critical request, such as loss of clock event. SR1 is for the common SCU request such as TSE request. SR2 is for ACMP and ORC requests. The service request outputs SR[2:0] are connected to interrupt nodes in the Nested Vectored Interrupt Controller (NVIC).

Refer to [Section 12.2.1](#) for more details.

## **12.7 Debug Behavior**

The SCU module does not get affected with the HALTED signal from SCU upon debug activities performed using external debug probe.

## **12.8 Power, Reset and Clock**

The SCU module implements functions that involve various types of modules controlled directly or via dedicated interfaces that are instantiated in different power, clock and reset domains. These modules are functionally considered parts of the SCU and therefore SCU is also considered a multi domain circuit in this sense.

### **Power domains:**

Power domains get separated with appropriate power separation cells.

- Core domain supplied with  $V_{DDC}$  voltage
- Pad domain supplied with  $V_{DDP}$  voltage

### **Clock domains:**

All cross-domain interfaces implement signal synchronization.

- internal SCU clock is MCLK, always identical to the CPU clock
- RTC and register mirror interface clock is 32.786 kHz clock generated from DCO2 oscillator

### **Reset domains:**

All resets get internally synchronized to respective clocks.

- System Reset ( $\overline{\text{SYSRESET}}$ ) resets most of the logics in SCU and can be triggered from various sources (please refer to [Reset Control \(RCU\)](#) section for more details)
- Master Reset ( $\overline{\text{MRESET}}$ ) contributes in generation of the System Reset and gets triggered upon power-up sequence of the Core domain

## 12.9 Registers

This section describes the registers of SCU which some of them resides in the ANACTRL module. Most of the registers are reset by SYSRESET reset signal but some of the registers can be reset only with power-on reset. SCU registers are accessible via the AHB-lite bus. ANACTRL registers are accessible via the APB bus. ANACTRL registers have name starting with “ANA”.

**Table 12-5 Base Addresses of sub-sections of SCU registers**

Short Name	Description	Offset Addr. <sup>1)</sup>
GCU Registers	Offset address of General Control Unit	0000 <sub>H</sub>
PCU Registers	Offset address of Power Control Unit	0200 <sub>H</sub>
CCU Registers	Offset address of Clock Control Unit	0300 <sub>H</sub>
RCU Registers	Offset address of Reset Control Unit	0400 <sub>H</sub>
RTC Registers	Offset address of Real Time Clock Module	0A00 <sub>H</sub>
ANACTRL Registers	Offset address of ANACTRL registers	1000 <sub>H</sub>

1) The absolute register address is calculated as follows:

Module Base Address + Sub-Module Offset Address (shown in this column) + Register Offset Address

Following access to SCU/ANACTRL SFRs result in an AHB/APB error response:

- Read or write access to undefined address
- Write access to read-only registers
- Write access to startup protected registers

**Table 12-6 Registers Address Space**

Module	Base Address	End Address	Note
SCU	4001 0000 <sub>H</sub>	4001 FFFF <sub>H</sub>	System Control Unit Registers

**Table 12-7 Registers Overview**

Short Name	Description	Offset Addr. <sup>1)</sup>	Access Mode		Description See
			Read	Write	
<b>PCU Registers (ANACTRL)</b>					
ANAVDEL	Voltage Detector Control register	1050 <sub>H</sub>	U, PV	U, PV	<a href="#">Page 12-24</a>
<b>PCU Registers (SCU)</b>					
VDESR	Voltage Detector Status Register	0000 <sub>H</sub>	U, PV	U, PV	<a href="#">Page 12-25</a>
<b>CCU Registers (SCU)</b>					
CLKCR	Clock Control	0000 <sub>H</sub>	U, PV	U, PV, BP	<a href="#">Page 12-26</a>
PWRSVCR	Power Save Control Register	0004 <sub>H</sub>	U, PV	U, PV	<a href="#">Page 12-28</a>
CGATSTAT0	Clock Gating Status for Peripherals 0	0008 <sub>H</sub>	U, PV	U, PV	<a href="#">Page 12-29</a>
CGATSET0	Clock Gating Set for Peripherals 0	000C <sub>H</sub>	U, PV	U, PV, BP	<a href="#">Page 12-30</a>
CGATCLR0	Clock Gating Clear for Peripherals 0	0010 <sub>H</sub>	U, PV	U, PV, BP	<a href="#">Page 12-32</a>
OSCCSR	Oscillator Control and Status Register	0014 <sub>H</sub>	U, PV	U, PV	<a href="#">Page 12-33</a>
<b>CCU Registers (ANACTRL)</b>					
ANAOFFSET	DCO1 Offset Register	106C <sub>H</sub>	U, PV	U, PV, BP	<a href="#">Page 12-35</a>
<b>RCU Registers (SCU)</b>					
RSTSTAT	Reset Status	0000 <sub>H</sub>	U, PV	BE	<a href="#">Page 12-36</a>
RSTSET	Reset Set Register	0004 <sub>H</sub>	U, PV	U, PV	<a href="#">Page 12-37</a>
RSTCLR	Reset Clear Register	0008 <sub>H</sub>	U, PV	U, PV	<a href="#">Page 12-37</a>
RSTCON	Reset Control Register	000C <sub>H</sub>	U, PV	U, PV	<a href="#">Page 12-38</a>
<b>GCU Registers (SCU)</b>					
ID	Module Identification Register	0008 <sub>H</sub>	U, PV	BE	<a href="#">Page 12-40</a>
IDCHIP	Chip ID	0004 <sub>H</sub>	U, PV	SP	<a href="#">Page 12-41</a>

**System Control Unit (SCU)**

**Table 12-7 Registers Overview (cont'd)**

Short Name	Description	Offset Addr. <sup>1)</sup>	Access Mode		Description See
			Read	Write	
DBGROMID	DBGROMID	0000 <sub>H</sub>	U, PV	SP	<a href="#">Page 12-41</a>
SSW0	SSW Support Register	0014 <sub>H</sub>	U, PV	U, PV	<a href="#">Page 12-42</a>
CCUCON	CCUx Global Start Control Register	0030 <sub>H</sub>	U, PV	U, PV	<a href="#">Page 12-42</a>
SRRAW	RAW Service Request Status	0038 <sub>H</sub>	U, PV	BE	<a href="#">Page 12-43</a>
SRMSK	Service Request Mask	003C <sub>H</sub>	U, PV	U, PV	<a href="#">Page 12-46</a>
SRCLR	Service Request Clear	0040 <sub>H</sub>	U, PV	U, PV	<a href="#">Page 12-48</a>
SRSET	Service Request Set	0044 <sub>H</sub>	U, PV	U, PV	<a href="#">Page 12-51</a>
PASSWD	Bit protection Register	0024 <sub>H</sub>	U, PV	U, PV	<a href="#">Page 12-54</a>
MIRRSTS	Mirror Update Status Register	0048 <sub>H</sub>	U, PV	BE	<a href="#">Page 12-55</a>
PMTSR	Parity Memory Test Select Register	0054 <sub>H</sub>	U, PV	U, PV	<a href="#">Page 12-56</a>

1) The absolute register address is calculated as follows:  
Module Base Address + Sub-Module Offset Address + Offset Address (shown in this column)

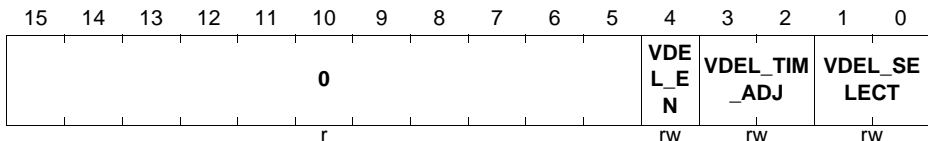
### 12.9.1 PCU Registers (ANACTRL)

#### ANAVDEL

Voltage Detector Control register.

#### ANAVDEL

**Voltage Detector Control Register (1050<sub>H</sub>)** **Reset Value:001C<sub>H</sub>**



Field	Bits	Type	Description
<b>VDEL_SELECT</b>	1:0	rw	<b>VDEL Range Select</b> With these bits the VDDP range is set. 00B 2.25V 01B 3.0V 10B 4.4V
<b>VDEL_TIM_ADJ</b>	3:2	rw	<b>VDEL Timing Setting</b> These bits control the reaction speed of the VDEL. The value is determined by characterisation. 00B typ 1µs - slowest response time 01B typ 500n 10B typ 250n 11B no delay - fastest response time.
<b>VDEL_EN</b>	4	rw	<b>VDEL unit Enable</b> 0B VDEL is disabled 1B VDEL is active
<b>0</b>	15:5	r	<b>Reserved</b> Read as 0; should be written with 0.

## 12.9.2 PCU Registers (SCU)

### VDESR

Voltage Detector status register.

### VDESR

**Voltage Detector Status Register (0200<sub>H</sub>)** **Reset Value: 0000 0000<sub>H</sub>**

31	30	29	28	27	26	25	24	23	22	21	20	19	18	17	16
0															
r															
15	14	13	12	11	10	9	8	7	6	5	4	3	2	1	0
0														VDD	VCLI
r														PPW	P
														rh	rh

**System Control Unit (SCU)**

Field	Bits	Type	Description
<b>VCLIP</b>	0	rh	<b>VCLIP Indication</b> VCLIP monitoring bit. 0 <sub>B</sub> VCLIP is not active 1 <sub>B</sub> VCLIP is active
<b>VDDPPW</b>	1	rh	<b>VDDPPW Indication</b> 0 <sub>B</sub> VDDP is above pre-warning threshold 1 <sub>B</sub> VDDP is below pre-warningthreshold
<b>0</b>	[31:2]	r	<b>Reserved</b> Read as 0; should be written with 0.

### 12.9.3 CCU Registers (SCU)

#### CLKCR

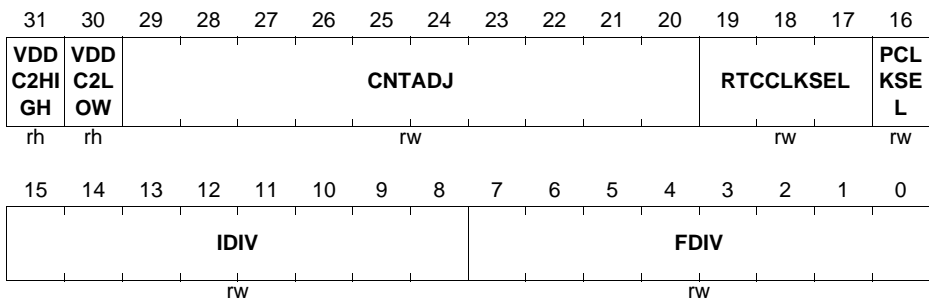
Clock control register.

#### CLKCR

Clock Control Register

(0300<sub>H</sub>)

Reset Value: 3FF0 0400<sub>H</sub>





**System Control Unit (SCU)**

Field	Bits	Type	Function
<b>FDIV</b>	[7:0]	rw	<p><b>Fractional Divider Selection</b></p> <p>Selects the fractional divider to be <math>n/256</math>, where <math>n</math> is the value of FDIV and is in the range of 0 to 255. For example, writing <math>0001_B</math> to FDIV selects the fractional divider to be <math>1/256</math>.</p> <p>This bit is protected by the bit protection scheme as described in Memory Organization chapter</p> <p><i>Note: Fractional divider has no effect if IDIV = <math>00_H</math>.</i></p>
<b>IDIV</b>	[15:8]	rw	<p><b>Divider Selection</b></p> <p><math>00_H</math> Divider is bypassed.  <math>01_H</math> 1; MCLK = 32 MHz  <math>02_H</math> 2; MCLK = 16 MHz  <math>03_H</math> 3; MCLK = 10.67 MHz  <math>04_H</math> 4; MCLK = 8 MHz  <math>FE_H</math> 254; MCLK = 126 kHz  <math>FF_H</math> 255; MCLK = 125.5 kHz</p> <p>This bit is protected by the bit protection scheme as described in Memory Organization chapter</p>
<b>PCLKSEL</b>	16	rw	<p><b>PCLK Clock Select</b></p> <p><math>0_B</math> PCLK = MCLK  <math>1_B</math> PCLK = 2 x MCLK</p> <p>This bit is protected by the bit protection scheme as described in Memory Organization chapter</p>
<b>RTCCLKSEL</b>	[19:17]	rw	<p><b>RTC Clock Select</b></p> <p><math>000_B</math> 32.768kHz standby clock  <math>001_B</math> 32.768kHz external clock from ERU0.IOUT0  <math>010_B</math> 32.768kHz external clock from ACMP0.OUT  <math>011_B</math> 32.768kHz external clock from ACMP1.OUT  <math>100_B</math> 32.768kHz external clock from ACMP2.OUT  <math>101_B</math> Reserved  <math>110_B</math> Reserved  <math>111_B</math> Reserved</p> <p>This bit is protected by the bit protection scheme as described in Memory Organization chapter</p>

**System Control Unit (SCU)**

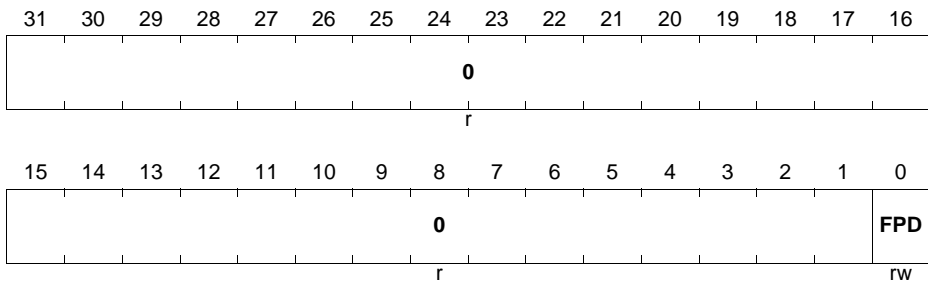
Field	Bits	Type	Function
<b>CNTADJ</b>	[29:20]	rw	<b>Counter Adjustment</b> 000 <sub>H</sub> 1 clock cycles of the DCO1, 64MHz clock 001 <sub>H</sub> 2 clock cycles of the DCO1, 64MHz clock 002 <sub>H</sub> 3 clock cycles of the DCO1, 64MHz clock 003 <sub>H</sub> 4 clock cycles of the DCO1, 64MHz clock 004 <sub>H</sub> 5 clock cycles of the DCO1, 64MHz clock 3FE <sub>H</sub> 1023 clock cycles of the DCO1, 64MHz clock 3FF <sub>H</sub> 1024 clock cycles of the DCO1, 64MHz clock
<b>VDDC2LOW</b>	30	rh	<b>VDDC too low</b> 0 <sub>B</sub> VDDC is not too low and the fractional divider input clock is running at the targeted frequency 1 <sub>B</sub> VDDC is too low and the fractional divider input clock is not running at the targeted frequency
<b>VDDC2HIGH</b>	31	rh	<b>VDDC too high</b> 0 <sub>B</sub> VDDC is not too high 1 <sub>B</sub> VDDC is too high

**PWRSVCR**

Configuration register that defines some system behaviour aspects while in deep-sleep mode or sleep mode. The original system state gets restored upon wakeup from sleep mode or deep-sleep mode.

**PWRSVCR**

**Power Save Control Register (0304<sub>H</sub>)**      **Reset Value: 0000 0000<sub>H</sub>**



Field	Bits	Type	Description
<b>FPD</b>	0	rw	<b>Flash Power Down</b> 0 <sub>B</sub> no effect 1 <sub>B</sub> Flash power down when entering power save mode. Upon wake-up, CPU is able to fetch code from flash.
<b>0</b>	[31:1]	r	<b>Reserved</b> Read as 0.

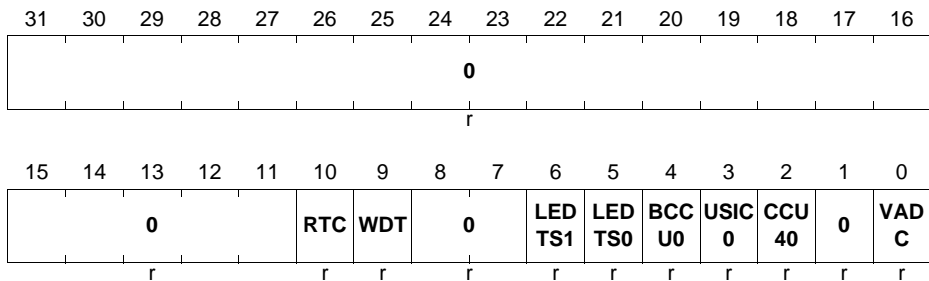
### CGATSTAT0

Clock gating status for XMC1200 peripherals. After reset, all peripherals as listed in the registers are not running. Their module clock are gated.

Every bit in this register is protected by the bit protection scheme as described in Memory Organization chapter.

### CGATSTAT0

**Peripheral 0 Clock Gating Status (0308<sub>H</sub>)**      **Reset Value: 0000 07FF<sub>H</sub>**



Field	Bits	Type	Description
<b>VADC</b>	0	r	<b>VADC and SHS Gating Status</b> 0 <sub>B</sub> gating de-asserted 1 <sub>B</sub> gating asserted
<b>CCU40</b>	2	r	<b>CCU40 Gating Status</b> 0 <sub>B</sub> gating de-asserted 1 <sub>B</sub> gating asserted

**System Control Unit (SCU)**

Field	Bits	Type	Description
<b>USIC0</b>	3	r	<b>USIC0 Gating Status</b> 0 <sub>B</sub> gating de-asserted 1 <sub>B</sub> gating asserted
<b>BCCU0</b>	4	r	<b>BCCU0 Gating Status</b> 0 <sub>B</sub> gating de-asserted 1 <sub>B</sub> gating asserted
<b>LEDTS0</b>	5	r	<b>LEDTS0 Gating Status</b> 0 <sub>B</sub> gating de-asserted 1 <sub>B</sub> gating asserted
<b>LEDTS1</b>	6	r	<b>LEDTS1 Gating Status</b> 0 <sub>B</sub> gating de-asserted 1 <sub>B</sub> gating asserted
<b>WDT</b>	9	r	<b>WDT Gating Status</b> 0 <sub>B</sub> gating de-asserted 1 <sub>B</sub> gating asserted
<b>RTC</b>	10	r	<b>RTC Gating Status</b> 0 <sub>B</sub> gating de-asserted 1 <sub>B</sub> gating asserted
<b>0</b>	1,[8:7], [31:11]	r	<b>Reserved</b>

**CGATSET0**

Clock gating enable for XMC1200 peripherals. Write one to selected bit to enable gating of corresponding clock, writing zeros has no effect.

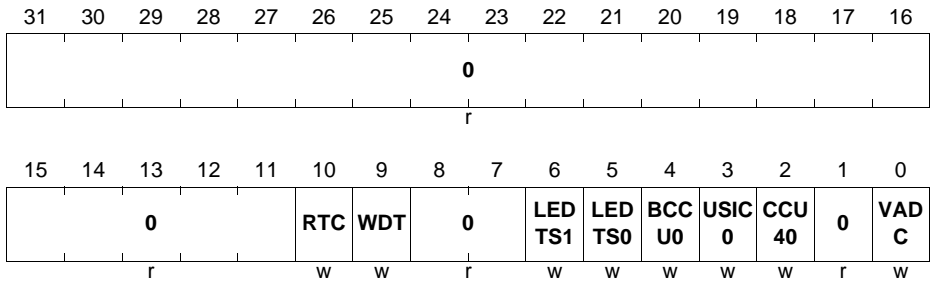
Every bit in this register is protected by the bit protection scheme as described in Memory Organization chapter.

**CGATSET0**

**Peripheral 0 Clock Gating Set**

**(030C<sub>H</sub>)**

**Reset Value: 0000 0000<sub>H</sub>**



Field	Bits	Type	Description
<b>VADC</b>	0	w	<b>VADC and SHS Gating Set</b> 0 <sub>B</sub> no effect 1 <sub>B</sub> enable gating
<b>CCU40</b>	2	w	<b>CCU40 Gating Set</b> 0 <sub>B</sub> no effect 1 <sub>B</sub> enable gating
<b>USIC0</b>	3	w	<b>USIC0 Gating Set</b> 0 <sub>B</sub> no effect 1 <sub>B</sub> enable gating
<b>BCCU0</b>	4	w	<b>BCCU0 Gating Set</b> 0 <sub>B</sub> no effect 1 <sub>B</sub> enable gating
<b>LEDTS0</b>	5	w	<b>LEDTS0 Gating Set</b> 0 <sub>B</sub> no effect 1 <sub>B</sub> enable gating
<b>LEDTS1</b>	6	w	<b>LEDTS1 Gating Set</b> 0 <sub>B</sub> no effect 1 <sub>B</sub> enable gating
<b>WDT</b>	9	w	<b>WDT Gating Set</b> 0 <sub>B</sub> no effect 1 <sub>B</sub> enable gating

**System Control Unit (SCU)**

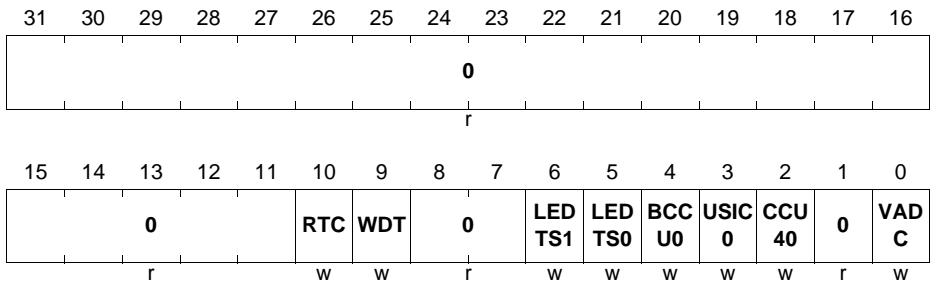
Field	Bits	Type	Description
<b>RTC</b>	10	w	<b>RTC Gating Set</b> 0 <sub>B</sub> no effect 1 <sub>B</sub> enable gating
<b>0</b>	1, [8:7], [31:11]	r	<b>Reserved</b>

**CGATCLR0**

Clock gating disable for XMC1200 peripherals. Write one to selected bit to disable gating of corresponding clock, writing zeros has no effect.

**CGATCLR0**

**Peripheral 0 Clock Gating Clear (0310<sub>H</sub>)**      **Reset Value: 0000 0000<sub>H</sub>**



Field	Bits	Type	Description
<b>VADC</b>	0	w	<b>VADC and SHS Gating Clear</b> 0 <sub>B</sub> no effect 1 <sub>B</sub> disable gating
<b>CCU40</b>	2	w	<b>CCU40 Gating Clear</b> 0 <sub>B</sub> no effect 1 <sub>B</sub> disable gating
<b>USIC0</b>	3	w	<b>USIC0 Gating Clear</b> 0 <sub>B</sub> no effect 1 <sub>B</sub> disable gating
<b>BCCU0</b>	4	w	<b>BCCU0 Gating Clear</b> 0 <sub>B</sub> no effect 1 <sub>B</sub> disable gating

**System Control Unit (SCU)**

Field	Bits	Type	Description
<b>LEDTS0</b>	5	w	<b>LEDTS0 Gating Clear</b> 0 <sub>B</sub> no effect 1 <sub>B</sub> disable gating
<b>LEDTS1</b>	6	w	<b>LEDTS1 Gating Clear</b> 0 <sub>B</sub> no effect 1 <sub>B</sub> disable gating
<b>WDT</b>	9	w	<b>WDT Gating Clear</b> 0 <sub>B</sub> no effect 1 <sub>B</sub> disable gating
<b>RTC</b>	10	w	<b>RTC Gating Clear</b> 0 <sub>B</sub> no effect 1 <sub>B</sub> disable gating
<b>0</b>	1, [8:7], [31:11]	r	<b>Reserved</b>

**OSCCSR**

Oscillator Control and Status Register.

**OSCCSR**

Oscillator Control and Status Register

(0314<sub>H</sub>)

Reset Value: 0000 000X<sub>H</sub>

31	30	29	28	27	26	25	24	23	22	21	20	19	18	17	16	<b>OWD</b>	<b>OWD</b>
0														<b>EN</b>	<b>RES</b>		
														r	rw	rwh	
15	14	13	12	11	10	9	8	7	6	5	4	3	2	1	0	<b>OSC</b>	<b>OSC</b>
0														<b>2H</b>	<b>2L</b>		
														r	rh	rh	

Field	Bits	Type	Description
<b>OSC2L</b>	0	rh	<p><b>Oscillator Valid Low Status Bit</b></p> <p>This bit indicates if the frequency output of OSC is usable. This is checked by the Oscillator Watchdog</p> <p>0<sub>B</sub> The OSC frequency is usable</p> <p>1<sub>B</sub> The OSC frequency is not usable. Frequency is too low.</p>
<b>OSC2H</b>	1	rh	<p><b>Oscillator Valid High Status Bit</b></p> <p>This bit indicates if the frequency output of OSC is usable. This is checked by the Oscillator Watchdog.</p> <p>0<sub>B</sub> The OSC frequency is usable</p> <p>1<sub>B</sub> The OSC frequency is not usable. Frequency is too high.</p>
<b>OWDRES</b>	16	rwh	<p><b>Oscillator Watchdog Reset</b></p> <p>Setting this bit will restart the oscillator detection. This bit will be automatically reset to 0 after OWD is reset which takes 2 standby clock cycles due to synchronisation.</p> <p>0<sub>B</sub> The Oscillator Watchdog is not cleared and remains active</p> <p>1<sub>B</sub> The Oscillator Watchdog is cleared and restarted. The OSC2L and OSC2H flag will be held in the last value until it is updated after 3 standby clock cycles.</p>
<b>OWDEN</b>	17	rw	<p><b>Oscillator Watchdog Enable</b></p> <p>0<sub>B</sub> The Oscillator Watchdog is disabled</p> <p>1<sub>B</sub> The Oscillator Watchdog is enabled</p> <p><i>Note: OSC2H and OSC2L will be cleared to 0 when OWD is disabled.</i></p>
<b>0</b>	[15:2], [31:18]	r	<p><b>Reserved</b></p> <p>Read as 0.</p>

## 12.9.4 CCU Registers (ANACTRL)

### ANAOFFSET

DCO1 Offset register.



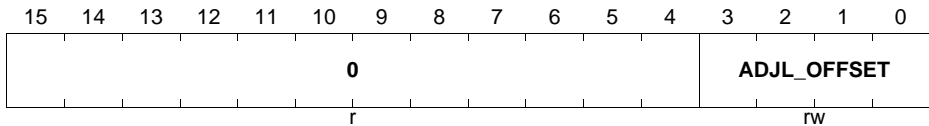
**System Control Unit (SCU)**

**ANAOFFSET**

**DCO1 Offset Register**

(106C<sub>H</sub>)

Reset Value: 0004<sub>H</sub>



Field	Bits	Type	Description
<b>ADJL_OFFSET</b>	3:0	rw	<p><b>ADJL Offset register</b></p> <p>The adjusted oscillator frequency can be varied according following scheme. The frequency step response depends on DCO_ADJR</p> <p>This bit is protected by the bit protection scheme as described in Memory Organization chapter</p> <p>0H - 4, typ. -1.2MHz (DCO_ADJR=0) or -1.8MHz (DCO_ADJR=1)</p> <p>1H - 3, typ. -0.9MHz (DCO_ADJR=0) or -1.35MHz (DCO_ADJR=1)</p> <p>4H 0, default</p> <p>5H + 1, typ. +0.3MHz (DCO_ADJR=0) or +0.45MHz (DCO_ADJR=1)</p> <p>8H + 4, typ. +1.2MHz (DCO_ADJR=0) or +1.8MHz (DCO_ADJR=1)</p>
<b>0</b>	15:4	r	<p><b>Reserved</b></p> <p>Read as 0; should be written with 0.</p>

**12.9.5 RCU Registers (SCU)**

**RSTSTAT**

Reset status register. This register needs to be checked after system startup in order to determine last reset reason. User should clear this register after reading it to ensure a clear status when the next reset happen. This register is reset by a power-on reset.

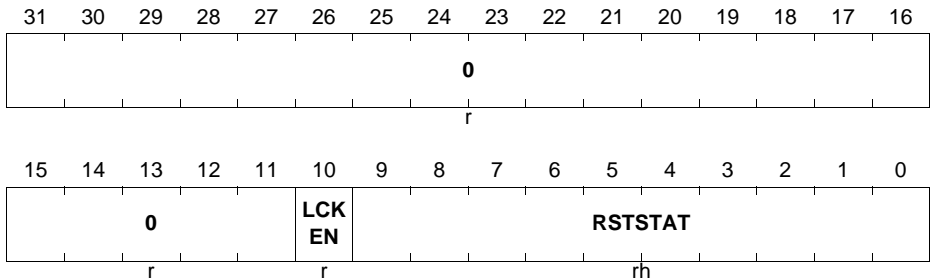
**System Control Unit (SCU)**

**RSTSTAT**

**RCU Reset Status**

**(0400<sub>H</sub>)**

**Reset Value: 0000 0XXX<sub>H</sub>**



Field	Bits	Type	Description
<b>RSTSTAT</b>	[9:0]	rh	<b>Reset Status Information</b> Provides reason of last reset 000000001 <sub>B</sub> Power on reset or Brownout reset XXXXXXXX1X <sub>B</sub> Master reset via bit RSTCON.MRSTEN XXXXXXX1XX <sub>B</sub> CPU system reset request XXXXXX1XXX <sub>B</sub> CPU lockup reset XXXXX1XXXX <sub>B</sub> Flash ECC reset XXXX1XXXXX <sub>B</sub> WDT reset XXX1XXXXXX <sub>B</sub> Loss of clock reset XX1XXXXXXX <sub>B</sub> Parity Error reset
<b>LCKEN</b>	10	r	<b>Enable Lockup Status</b> 0 <sub>B</sub> Reset by Lockup disabled 1 <sub>B</sub> Reset by Lockup enabled
<b>0</b>	[31:11]	r	<b>Reserved</b>

**RSTSET**

Selective configuration of reset behaviour in the system. Write one to set selected bit, writing zeros has no effect.

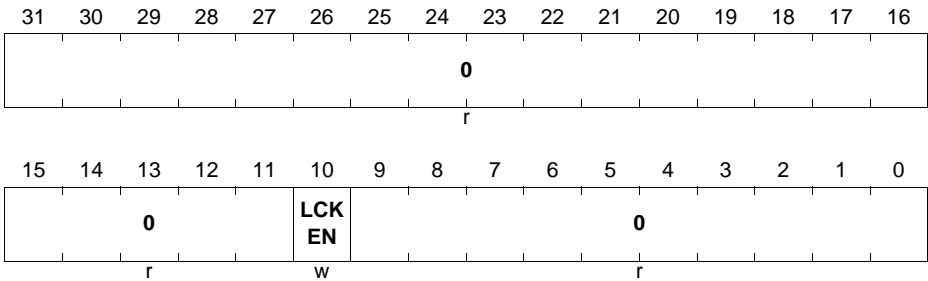
**System Control Unit (SCU)**

**RSTSET**

**RCU Reset Set Register**

**(0404<sub>H</sub>)**

**Reset Value: 0000 0000<sub>H</sub>**



Field	Bits	Type	Description
<b>LCKEN</b>	10	w	<b>Enable Lockup Reset</b> 0 <sub>B</sub> no effect 1 <sub>B</sub> Enable reset when Lockup gets asserted
<b>0</b>	[9:0], [31:11]	r	<b>Reserved</b>

**RSTCLR**

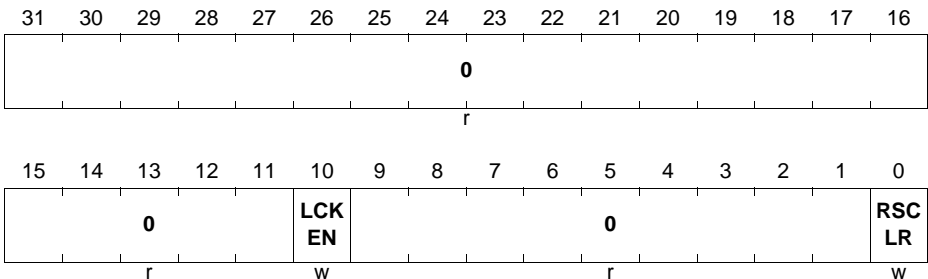
Selective configuration of reset behaviour in the system. Write one to clear selected bit, writing zeros has no effect.

**RSTCLR**

**RCU Reset Clear Register**

**(0408<sub>H</sub>)**

**Reset Value: 0000 0000<sub>H</sub>**



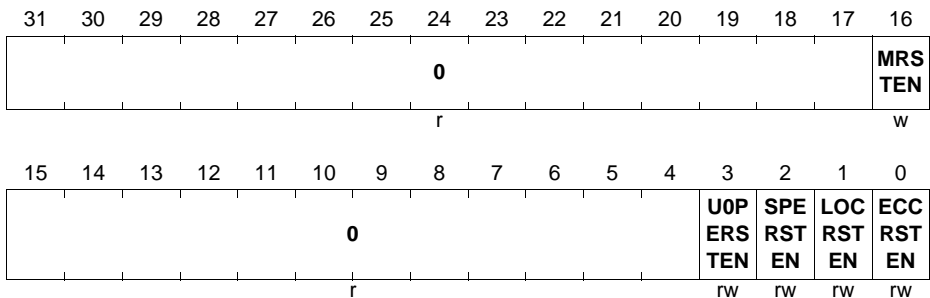
Field	Bits	Type	Description
<b>RSCLR</b>	0	w	<b>Clear Reset Status</b> 0 <sub>B</sub> no effect 1 <sub>B</sub> Clears field <b>RSTSTAT.RSTSTAT</b>
<b>LCKEN</b>	10	w	<b>Enable Lockup Reset</b> 0 <sub>B</sub> no effect 1 <sub>B</sub> Disable reset when Lockup gets asserted
<b>0</b>	[9:1], [31:11]	r	<b>Reserved</b>

### RSTCON

Enabling of reset triggered by critical events. It is reset by any reset type.

### RSTCON

**RCU Reset Control Register (040C<sub>H</sub>)**      **Reset Value: 0000 0000<sub>H</sub>**



Field	Bits	Type	Description
<b>ECCRSTEN</b>	0	rw	<b>Enable ECC Error Reset</b> 0 <sub>B</sub> No reset when ECC double bit error occur 1 <sub>B</sub> Reset when ECC double bit error occur
<b>LOCRSTEN</b>	1	rw	<b>Enable Loss of Clock Reset</b> 0 <sub>B</sub> No reset when loss of clock occur 1 <sub>B</sub> Reset when loss of clock occur
<b>SPERSTEN</b>	2	rw	<b>Enable 16kbytes SRAM Parity Error Reset</b> 0 <sub>B</sub> No reset when SRAM parity error occur 1 <sub>B</sub> Reset when SRAM parity error occur

**System Control Unit (SCU)**

Field	Bits	Type	Description
<b>UOPERSTEN</b>	3	rw	<b>Enable USIC0 SRAM Parity Error Reset</b> 0 <sub>B</sub> No reset when USIC0 memory parity error occur 1 <sub>B</sub> Reset when USIC0 memory parity error occur
<b>MRSTEN</b>	16	w	<b>Enable Master Reset</b> 0 <sub>B</sub> No effect 1 <sub>B</sub> Triggered Master reset
<b>0</b>	[15:4], [31:17]	r	<b>Reserved</b>

## 12.9.6 GCU Registers (SCU)

### ID

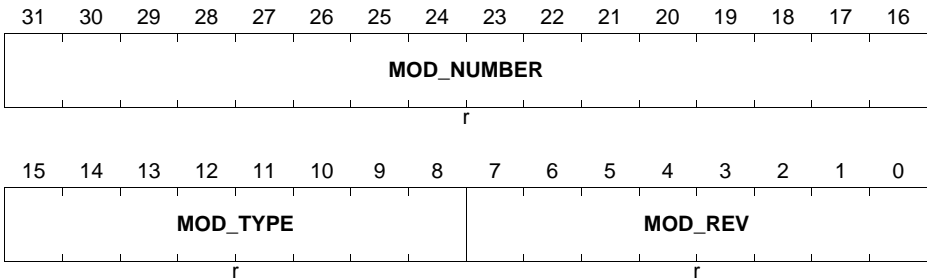
Register containing unique ID of the module.

### ID

#### SCU Module ID Register

(0008<sub>H</sub>)

Reset Value: 00F1 C0XX<sub>H</sub>



Field	Bits	Type	Description
MOD_REV	[7:0]	r	<b>Module Revision Number</b> MOD_REV defines the revision number. The value of a module revision starts with 01 <sub>H</sub> (first revision).
MOD_TYPE	[15:8]	r	<b>Module Type</b> This bit field is C0 <sub>H</sub> . It defines the module as a 32-bit module.
MOD_NUMBER	[31:16]	r	<b>Module Number Value</b> This bit field defines the module identification number.

### IDCHIP

Register containing a unique ID of the chip in the XMC family. The value of this register formed part of the chip identification number as described in [Chip Identification Number](#).

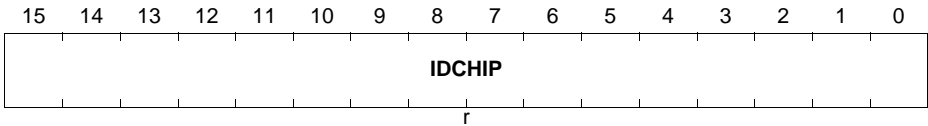
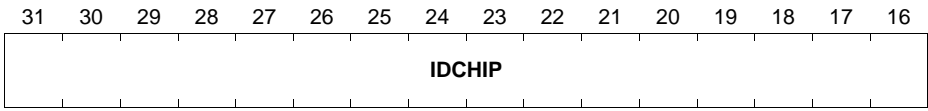
**System Control Unit (SCU)**

**IDCHIP**

**Chip ID Register**

**(0004<sub>H</sub>)**

**Reset Value: 0000 0000<sub>H</sub>**



Field	Bits	Type	Description
<b>IDCHIP</b>	[31:0]	r	<b>CHIP ID</b> 0001 2XXX <sub>H</sub> XCM1200 0001 XXX2 <sub>H</sub> temperature : -40 - 85 °C 0001 XXX3 <sub>H</sub> temperature : -40 - 105 °C 0001 XX1X <sub>H</sub> TSSOP38 pin package 0001 XX2X <sub>H</sub> TSSOP28 pin package 0001 XX3X <sub>H</sub> TSSOP16 pin package Others Reserved

**DBGROMID**

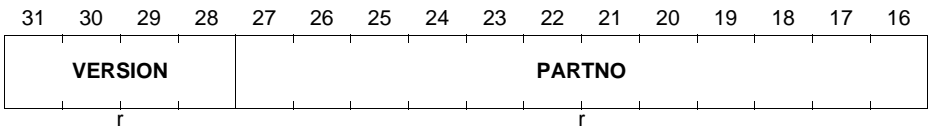
Register containing unique manufactory ID, part number and the design stepping code of the chip.

**DBGROMID**

**Debug System ROM ID Register**

**(0000<sub>H</sub>)**

**Reset Value: 101E D083<sub>H</sub>**



Field	Bits	Type	Description
<b>MANUFID</b>	[11:1]	r	<b>Manufactory Identity</b>
<b>PARTNO</b>	[27:12]	r	<b>Part Number</b>
<b>VERSION</b>	[31:28]	r	<b>Product version</b>
<b>1</b>	0	r	<b>Reserved</b> Read as 0; should be written with 0.

### SSW0

Software support registers.

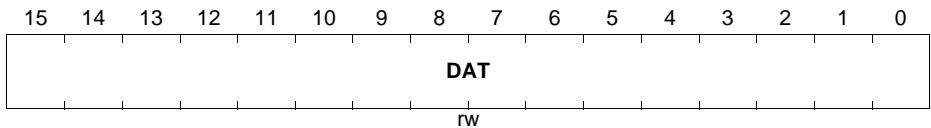
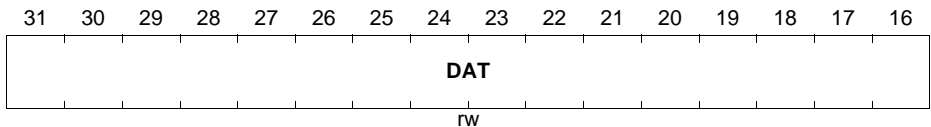
SSW0 is used to change the BMI value.

### SSW0

**SSW Register 0**

**(0014<sub>H</sub>)**

**Reset Value: 0000 0000<sub>H</sub>**



Field	Bits	Type	Description
<b>DAT</b>	[31:0]	rw	<b>SSW Data</b> <i>Note: SSW registers can be reset with master reset only</i>

### CCUCON

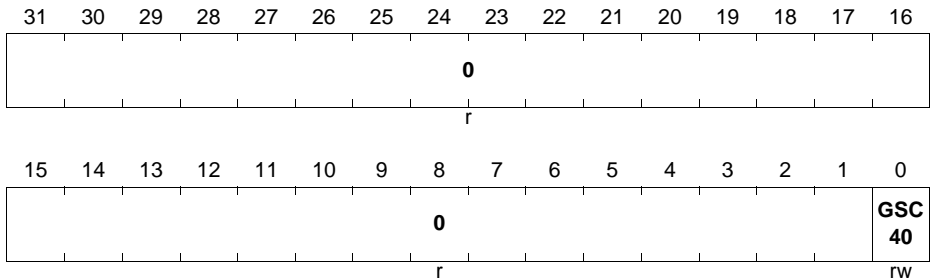
CAPCOM module control register.



**System Control Unit (SCU)**

**CCUCON**

**CCU Control Register (0030<sub>H</sub>) Reset Value: 0000 0000<sub>H</sub>**



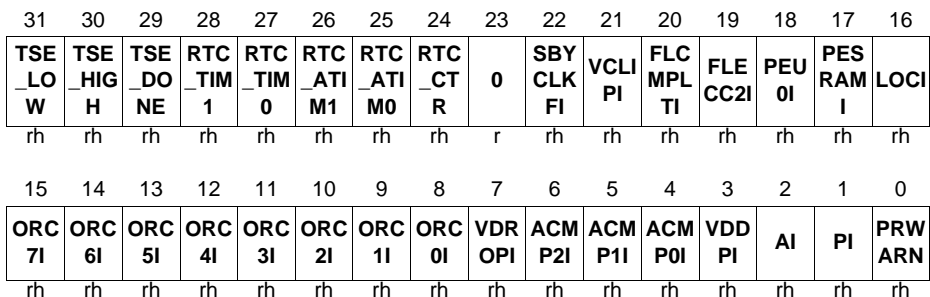
Field	Bits	Type	Description
<b>GSC40</b>	0	rw	<b>Global Start Control CCU40</b> 0 <sub>B</sub> disable 1 <sub>B</sub> enable
<b>0</b>	[31:1]	r	<b>Reserved</b> Read as 0; should be written with 0.

**SRRAW**

Service request status without masking. Write one to a bit in SRCLR register to clear a bit or SRSET to set a bit. Writing zero has no effect.

**SRRAW**

**SCU Raw Service Request Status (0038<sub>H</sub>) Reset Value: 0000 0000<sub>H</sub>**



<b>Field</b>	<b>Bits</b>	<b>Type</b>	<b>Description</b>
<b>PRWARN</b>	0	rh	<b>WDT pre-warning Event Status Before Masking</b> 0 <sub>B</sub> Event has not occurred 1 <sub>B</sub> Event has occurred
<b>PI</b>	1	rh	<b>RTC Raw Periodic Event Status Before Masking</b> 0 <sub>B</sub> Event has not occurred 1 <sub>B</sub> Event has occurred
<b>AI</b>	2	rh	<b>RTC Raw Alarm Event Status Before Masking</b> 0 <sub>B</sub> Event has not occurred 1 <sub>B</sub> Event has occurred
<b>VDDPI</b>	3	rh	<b>VDDP pre-warning Event Status Before Masking</b> 0 <sub>B</sub> Event has not occurred 1 <sub>B</sub> Event has occurred
<b>ACMP0I</b>	4	rh	<b>Analog Comparator 0 Event Status Before Masking</b> 0 <sub>B</sub> Event has not occurred 1 <sub>B</sub> Event has occurred
<b>ACMP1I</b>	5	rh	<b>Analog Comparator 1 Event Status Before Masking</b> 0 <sub>B</sub> Event has not occurred 1 <sub>B</sub> Event has occurred
<b>ACMP2I</b>	6	rh	<b>Analog Comparator 2 Event Status Before Masking</b> 0 <sub>B</sub> Event has not occurred 1 <sub>B</sub> Event has occurred
<b>VDR0PI</b>	7	rh	<b>VDR0P Event Status Before Masking</b> 0 <sub>B</sub> Event has not occurred 1 <sub>B</sub> Event has occurred
<b>ORCxI (x=0-7)</b>	x+8	rh	<b>Out of Range Comparator X Event Status Before Masking</b> 0 <sub>B</sub> Event has not occurred 1 <sub>B</sub> Event has occurred
<b>LOCI</b>	16	rh	<b>Loss of Clock Event Status Before Masking</b> 0 <sub>B</sub> Event has not occurred 1 <sub>B</sub> Event has occurred

**System Control Unit (SCU)**

<b>Field</b>	<b>Bits</b>	<b>Type</b>	<b>Description</b>
<b>PESRAMI</b>	17	rh	<b>16kbytes SRAM Parity Error Event Status Before Masking</b> 0 <sub>B</sub> Event has not occurred 1 <sub>B</sub> Event has occurred
<b>PEU0I</b>	18	rh	<b>USIC0 SRAM Parity Error Event Status Before Masking</b> 0 <sub>B</sub> Event has not occurred 1 <sub>B</sub> Event has occurred
<b>FLECC2I</b>	19	rh	<b>Flash Double Bit ECC Event Status Before Masking</b> 0 <sub>B</sub> Event has not occurred 1 <sub>B</sub> Event has occurred
<b>FLCMPLTI</b>	20	rh	<b>Flash Operation Complete Event Status Before Masking</b> 0 <sub>B</sub> Event has not occurred 1 <sub>B</sub> Event has occurred
<b>VCLIP I</b>	21	rh	<b>VCLIP Event Status Before Masking</b> 0 <sub>B</sub> Event has not occurred 1 <sub>B</sub> Event has occurred
<b>SBYCLKFI</b>	22	rh	<b>Standby Clock Failure Event Status Before Masking</b> 0 <sub>B</sub> No standby clock failure has occurred 1 <sub>B</sub> Standby clock failure has occurred
<b>RTC_CTR</b>	24	rh	<b>RTC CTR Mirror Register Update Status Before Masking</b> 0 <sub>B</sub> not updated 1 <sub>B</sub> update completed
<b>RTC_ATIM0</b>	25	rh	<b>RTC ATIM0 Mirror Register Update Status Before Masking</b> 0 <sub>B</sub> not updated 1 <sub>B</sub> update completed
<b>RTC_ATIM1</b>	26	rh	<b>RTC ATIM1 Mirror Register Update Status Before Masking</b> 0 <sub>B</sub> not updated 1 <sub>B</sub> update completed

**System Control Unit (SCU)**

Field	Bits	Type	Description
RTC_TIM0	27	rh	<b>RTC TIM0 Mirror Register Update Before Masking</b> 0 <sub>B</sub> not updated 1 <sub>B</sub> update completed
RTC_TIM1	28	rh	<b>RTC TIM1 Mirror Register Update Status Before Masking</b> 0 <sub>B</sub> not updated 1 <sub>B</sub> update completed
TSE_DONE	29	rh	<b>TSE Measurement Done Event Status Before Masking</b> 0 <sub>B</sub> Event has not occurred 1 <sub>B</sub> Event has occurred
TSE_HIGH	30	rh	<b>TSE Compare High Temperature Event Status Before Masking</b> 0 <sub>B</sub> Event has not occurred 1 <sub>B</sub> Event has occurred
TSE_LOW	31	rh	<b>TSE Compare Low Temperature Event Status Before Masking</b> 0 <sub>B</sub> Event has not occurred 1 <sub>B</sub> Event has occurred
0	23	r	<b>Reserved</b>

**SRMSK**

Service request mask used to mask outputs of RAW register. When the bit is set to 1, an interrupt or service request will be triggered when the event happens.

**SRMSK**

**SCU Service Request Mask (003C<sub>H</sub>) Reset Value: 0000 0000<sub>H</sub>**

31	30	29	28	27	26	25	24	23	22	21	20	19	18	17	16
TSE _LO W	TSE _HIG H	TSE _DO NE	RTC _TIM 1	RTC _TIM 0	RTC _ATI M1	RTC _ATI M0	RTC _CT R	0	SBY CLK FI	VCLI PI	0	FLE CC2I	PEU OI	PES RAM I	LOCI
rw	rw	rw	rw	rw	rw	rw	rw	r	rw	rw	r	rw	rw	rw	rw
15	14	13	12	11	10	9	8	7	6	5	4	3	2	1	0
ORC 7I	ORC 6I	ORC 5I	ORC 4I	ORC 3I	ORC 2I	ORC 1I	ORC 0I	VDR OPI	ACM P2I	ACM P1I	ACM P0I	VDD PI	0	PRW ARN	
rw	rw	rw	rw	rw	rw	rw	rw	rw	rw	rw	rw	rw	r	rw	

<b>Field</b>	<b>Bits</b>	<b>Type</b>	<b>Description</b>
<b>PRWARN</b>	0	rw	<b>WDT pre-warning Interrupt Mask</b> 0 <sub>B</sub> disable interrupt 1 <sub>B</sub> enable interrupt
<b>VDDPI</b>	3	rw	<b>VDDP pre-warning Interrupt Mask</b> 0 <sub>B</sub> disable interrupt 1 <sub>B</sub> enable interrupt
<b>ACMP0I</b>	4	rw	<b>Analog Comparator 0 Interrupt Mask</b> 0 <sub>B</sub> disable interrupt 1 <sub>B</sub> enable interrupt
<b>ACMP1I</b>	5	rw	<b>Analog Comparator 1 Interrupt Mask</b> 0 <sub>B</sub> disable interrupt 1 <sub>B</sub> enable interrupt
<b>ACMP2I</b>	6	rw	<b>Analog Comparator 2 Interrupt Mask</b> 0 <sub>B</sub> disable interrupt 1 <sub>B</sub> enable interrupt
<b>VDR0PI</b>	7	rw	<b>VDR0P Interrupt Mask</b> 0 <sub>B</sub> disable interrupt 1 <sub>B</sub> enable interrupt
<b>ORCxI (x=0-7)</b>	x+8	rw	<b>Out of Range Comparator X Interrupt Mask</b> 0 <sub>B</sub> disable interrupt 1 <sub>B</sub> enable interrupt
<b>LOCI</b>	16	rw	<b>Loss of Clock Interrupt Mask</b> 0 <sub>B</sub> disable interrupt 1 <sub>B</sub> enable interrupt
<b>PESRAMI</b>	17	rw	<b>16kbytes SRAM Parity Error Interrupt Mask</b> 0 <sub>B</sub> disable interrupt 1 <sub>B</sub> enable interrupt
<b>PEU0I</b>	18	rw	<b>USIC0 SRAM Parity Error Interrupt Mask</b> 0 <sub>B</sub> disable interrupt 1 <sub>B</sub> enable interrupt
<b>FLECC2I</b>	19	rw	<b>Flash Double Bit ECC Interrupt Mask</b> 0 <sub>B</sub> disable interrupt 1 <sub>B</sub> enable interrupt
<b>VCLIP I</b>	21	rw	<b>VCLIP Interrupt Mask</b> 0 <sub>B</sub> disable interrupt 1 <sub>B</sub> enable interrupt

**System Control Unit (SCU)**

Field	Bits	Type	Description
<b>SBYCLKFI</b>	22	rw	<b>Standby Clock Failure Interrupt Mask</b> 0 <sub>B</sub> disable interrupt 1 <sub>B</sub> enable interrupt
<b>RTC_CTR</b>	24	rw	<b>RTC CTR Mirror Register Update Mask</b> 0 <sub>B</sub> disable interrupt 1 <sub>B</sub> enable interrupt
<b>RTC_ATIM0</b>	25	rw	<b>RTC ATIM0 Mirror Register Update Mask</b> 0 <sub>B</sub> disable interrupt 1 <sub>B</sub> enable interrupt
<b>RTC_ATIM1</b>	26	rw	<b>RTC ATIM1 Mirror Register Update Mask</b> 0 <sub>B</sub> disable interrupt 1 <sub>B</sub> enable interrupt
<b>RTC_TIM0</b>	27	rw	<b>RTC TIM0 Mirror Register Update Mask</b> 0 <sub>B</sub> disable interrupt 1 <sub>B</sub> enable interrupt
<b>RTC_TIM1</b>	28	rw	<b>RTC TIM1 Mirror Register Update Mask</b> 0 <sub>B</sub> disable interrupt 1 <sub>B</sub> enable interrupt
<b>TSE_DONE</b>	29	rw	<b>TSE Measurement Done Interrupt Mask</b> 0 <sub>B</sub> disable interrupt 1 <sub>B</sub> enable interrupt
<b>TSE_HIGH</b>	30	rw	<b>TSE Compare High Temperature Interrupt Mask</b> 0 <sub>B</sub> disable interrupt 1 <sub>B</sub> enable interrupt
<b>TSE_LOW</b>	31	rw	<b>TSE Compare Low Temperature Interrupt Mask</b> 0 <sub>B</sub> disable interrupt 1 <sub>B</sub> enable interrupt
<b>0</b>	[2:1], 20, 23	r	<b>Reserved</b>

### SRCLR

Clear service request bits of register SRRAW. Write one to clear corresponding bits. Writing zeros has no effect.

**System Control Unit (SCU)**

**SRCLR**

**SCU Service Request Clear**

**(0040<sub>H</sub>)**

**Reset Value: 0000 0000<sub>H</sub>**

31	30	29	28	27	26	25	24	23	22	21	20	19	18	17	16
<b>TSE _LO W</b>	<b>TSE _HIG H</b>	<b>TSE _DO NE</b>	<b>RTC _TIM _1</b>	<b>RTC _TIM _0</b>	<b>RTC _ATI _M1</b>	<b>RTC _ATI _M0</b>	<b>RTC _CT _R</b>	<b>0</b>	<b>SBY CLK FI</b>	<b>VCLI PI</b>	<b>FLC MPL TI</b>	<b>FLE CC2I</b>	<b>PEU OI</b>	<b>PES RAM I</b>	<b>LOCI</b>
w	w	w	w	w	w	w	w	r	w	w	w	w	w	w	w
15	14	13	12	11	10	9	8	7	6	5	4	3	2	1	0
<b>ORC 7I</b>	<b>ORC 6I</b>	<b>ORC 5I</b>	<b>ORC 4I</b>	<b>ORC 3I</b>	<b>ORC 2I</b>	<b>ORC 1I</b>	<b>ORC 0I</b>	<b>VDR OPI</b>	<b>ACM P2I</b>	<b>ACM P1I</b>	<b>ACM P0I</b>	<b>VDD PI</b>	<b>AI</b>	<b>PI</b>	<b>PRW ARN</b>
w	w	w	w	w	w	w	w	w	w	w	w	w	w	w	w

<b>Field</b>	<b>Bits</b>	<b>Type</b>	<b>Description</b>
<b>PRWARN</b>	0	w	<b>WDT pre-warning Interrupt Clear</b> 0 <sub>B</sub> no effect 1 <sub>B</sub> clear status bit in the raw status register
<b>PI</b>	1	w	<b>RTC Periodic Interrupt Clear</b> 0 <sub>B</sub> no effect 1 <sub>B</sub> clear status bit in the raw status register
<b>AI</b>	2	w	<b>RTC Alarm Interrupt Clear</b> 0 <sub>B</sub> no effect 1 <sub>B</sub> clear status bit in the raw status register
<b>VDDPI</b>	3	w	<b>VDDP pre-warning Interrupt Clear</b> 0 <sub>B</sub> no effect 1 <sub>B</sub> clear status bit in the raw status register
<b>ACMP0I</b>	4	w	<b>Analog Comparator 0 Interrupt Clear</b> 0 <sub>B</sub> no effect 1 <sub>B</sub> clear status bit in the raw status register
<b>ACMP1I</b>	5	w	<b>Analog Comparator 1 Interrupt Clear</b> 0 <sub>B</sub> no effect 1 <sub>B</sub> clear status bit in the raw status register
<b>ACMP2I</b>	6	w	<b>Analog Comparator 2 Interrupt Clear</b> 0 <sub>B</sub> no effect 1 <sub>B</sub> clear status bit in the raw status register
<b>VDR0PI</b>	7	w	<b>VDR0P Interrupt Clear</b> 0 <sub>B</sub> no effect 1 <sub>B</sub> clear status bit in the raw status register

**System Control Unit (SCU)**

Field	Bits	Type	Description
<b>ORCxI (x=0-7)</b>	x+8	w	<b>Out of Range Comparator X Interrupt Clear</b> 0 <sub>B</sub> no effect 1 <sub>B</sub> clear status bit in the raw status register
<b>LOCI</b>	16	w	<b>Loss of Clock Interrupt Clear</b> 0 <sub>B</sub> no effect 1 <sub>B</sub> clear status bit in the raw status register
<b>PESRAMI</b>	17	w	<b>16kbytes SRAM Parity Error Interrupt Clear</b> 0 <sub>B</sub> no effect 1 <sub>B</sub> clear status bit in the raw status register
<b>PEU0I</b>	18	w	<b>USIC0 SRAM Parity Error Interrupt Clear</b> 0 <sub>B</sub> no effect 1 <sub>B</sub> clear status bit in the raw status register
<b>FLECC2I</b>	19	w	<b>Flash Double Bit ECC Interrupt Clear</b> 0 <sub>B</sub> no effect 1 <sub>B</sub> clear status bit in the raw status register
<b>FLCMLPTI</b>	20	w	<b>Flash Operation Complete Interrupt Clear</b> 0 <sub>B</sub> no effect 1 <sub>B</sub> clear status bit in the raw status register
<b>VCLIP I</b>	21	w	<b>VCLIP Interrupt Clear</b> 0 <sub>B</sub> no effect 1 <sub>B</sub> clear status bit in the raw status register
<b>SBYCLKFI</b>	22	w	<b>Standby Clock Failure Interrupt Clear</b> 0 <sub>B</sub> no effect 1 <sub>B</sub> clear status bit in the raw status register
<b>RTC_CTR</b>	24	w	<b>RTC CTR Mirror Register Update Clear</b> 0 <sub>B</sub> no effect 1 <sub>B</sub> clear status bit in the raw status register
<b>RTC_ATIM0</b>	25	w	<b>RTC ATIM0 Mirror Register Update Clear</b> 0 <sub>B</sub> no effect 1 <sub>B</sub> clear status bit in the raw status register
<b>RTC_ATIM1</b>	26	w	<b>RTC ATIM1 Mirror Register Update Clear</b> 0 <sub>B</sub> no effect 1 <sub>B</sub> clear status bit in the raw status register
<b>RTC_TIM0</b>	27	w	<b>RTC TIM0 Mirror Register Update Clear</b> 0 <sub>B</sub> no effect 1 <sub>B</sub> clear status bit in the raw status register



**System Control Unit (SCU)**

Field	Bits	Type	Description
<b>RTC_TIM1</b>	28	w	<b>RTC TIM1 Mirror Register Update Clear</b> 0 <sub>B</sub> no effect 1 <sub>B</sub> clear status bit in the raw status register
<b>TSE_DONE</b>	29	w	<b>TSE Measurement Done Interrupt Clear</b> 0 <sub>B</sub> no effect 1 <sub>B</sub> clear status bit in the raw status register
<b>TSE_HIGH</b>	30	w	<b>TSE Compare High Temperature Interrupt Clear</b> 0 <sub>B</sub> no effect 1 <sub>B</sub> clear status bit in the raw status register
<b>TSE_LOW</b>	31	w	<b>TSE Compare Low Temperature Interrupt Clear</b> 0 <sub>B</sub> no effect 1 <sub>B</sub> clear status bit in the raw status register
<b>0</b>	23	r	<b>Reserved</b>

**SRSET**

Set service request bits of register SRRAW. Write one to set corresponding bits. Writing zeros has no effect.

**SRSET**

**SCU Service Request Set**

**(0044<sub>H</sub>)**

**Reset Value: 0000 0000<sub>H</sub>**

31	30	29	28	27	26	25	24	23	22	21	20	19	18	17	16
<b>TSE_LO</b>	<b>TSE_HI</b>	<b>TSE_DO</b>	<b>RTC_TIM1</b>	<b>RTC_TIM0</b>	<b>RTC_ATI_M1</b>	<b>RTC_ATI_M0</b>	<b>RTC_CT_R</b>	<b>0</b>	<b>SBY_CLK_FI</b>	<b>VCLI_PI</b>	<b>FLC_MPL_TI</b>	<b>FLE_CC2I</b>	<b>PEU_OI</b>	<b>PES_RAM_I</b>	<b>LOCI</b>
w	w	w	w	w	w	w	w	r	w	w	w	w	w	w	w
15	14	13	12	11	10	9	8	7	6	5	4	3	2	1	0
<b>ORC_7I</b>	<b>ORC_6I</b>	<b>ORC_5I</b>	<b>ORC_4I</b>	<b>ORC_3I</b>	<b>ORC_2I</b>	<b>ORC_1I</b>	<b>ORC_0I</b>	<b>VDR_OPI</b>	<b>ACM_P2I</b>	<b>ACM_P1I</b>	<b>ACM_P0I</b>	<b>VDD_PI</b>	<b>AI</b>	<b>PI</b>	<b>PRW_ARN</b>
w	w	w	w	w	w	w	w	w	w	w	w	w	w	w	w

Field	Bits	Type	Description
<b>PRWARN</b>	0	w	<b>WDT pre-warning Interrupt Set</b> 0 <sub>B</sub> no effect 1 <sub>B</sub> set status bit in the raw status register

**System Control Unit (SCU)**

Field	Bits	Type	Description
PI	1	w	<b>RTC Periodic Interrupt Set</b> 0 <sub>B</sub> no effect 1 <sub>B</sub> set status bit in the raw status register
AI	2	w	<b>RTC Alarm Interrupt Set</b> 0 <sub>B</sub> no effect 1 <sub>B</sub> set status bit in the raw status register
VDDPI	3	w	<b>VDDP pre-warning Interrupt Set</b> 0 <sub>B</sub> no effect 1 <sub>B</sub> set status bit in the raw status register
ACMP0I	4	w	<b>Analog Comparator 0 Interrupt Set</b> 0 <sub>B</sub> no effect 1 <sub>B</sub> set status bit in the raw status register
ACMP1I	5	w	<b>Analog Comparator 1 Interrupt Set</b> 0 <sub>B</sub> no effect 1 <sub>B</sub> set status bit in the raw status register
ACMP2I	6	w	<b>Analog Comparator 2 Interrupt Set</b> 0 <sub>B</sub> no effect 1 <sub>B</sub> set status bit in the raw status register
VDR0PI	7	w	<b>VDR0P Interrupt Set</b> 0 <sub>B</sub> no effect 1 <sub>B</sub> set status bit in the raw status register
ORCxI (x=0-7)	x+8	w	<b>Out of Range Comparator X Interrupt Set</b> 0 <sub>B</sub> no effect 1 <sub>B</sub> set status bit in the raw status register
LOCI	16	w	<b>Loss of Clock Interrupt Set</b> 0 <sub>B</sub> no effect 1 <sub>B</sub> set status bit in the raw status register
PESRAMI	17	w	<b>16kbytes SRAM Parity Error Interrupt Set</b> 0 <sub>B</sub> no effect 1 <sub>B</sub> set status bit in the raw status register
PEU0I	18	w	<b>USIC0 SRAM Parity Error Interrupt Set</b> 0 <sub>B</sub> no effect 1 <sub>B</sub> set status bit in the raw status register
FLECC2I	19	w	<b>Flash Double Bit ECC Interrupt Set</b> 0 <sub>B</sub> no effect 1 <sub>B</sub> set status bit in the raw status register

**System Control Unit (SCU)**

Field	Bits	Type	Description
<b>FLCMPLTI</b>	20	w	<b>Flash Operation Complete Interrupt Set</b> 0 <sub>B</sub> no effect 1 <sub>B</sub> set status bit in the raw status register
<b>VCLIP</b>	21	w	<b>VCLIP Interrupt Set</b> 0 <sub>B</sub> no effect 1 <sub>B</sub> set status bit in the raw status register
<b>SBYCLKFI</b>	22	w	<b>Standby Clock Failure Interrupt Set</b> 0 <sub>B</sub> no effect 1 <sub>B</sub> set status bit in the raw status register
<b>RTC_CTR</b>	24	w	<b>RTC CTR Mirror Register Update Set</b> 0 <sub>B</sub> no effect 1 <sub>B</sub> set status bit in the raw status register
<b>RTC_ATIM0</b>	25	w	<b>RTC ATIM0 Mirror Register Update Set</b> 0 <sub>B</sub> no effect 1 <sub>B</sub> set status bit in the raw status register
<b>RTC_ATIM1</b>	26	w	<b>RTC ATIM1 Mirror Register Update Set</b> 0 <sub>B</sub> no effect 1 <sub>B</sub> set status bit in the raw status register
<b>RTC_TIM0</b>	27	w	<b>RTC TIM0 Mirror Register Update Set</b> 0 <sub>B</sub> no effect 1 <sub>B</sub> set status bit in the raw status register
<b>RTC_TIM1</b>	28	w	<b>RTC TIM1 Mirror Register Update Set</b> 0 <sub>B</sub> no effect 1 <sub>B</sub> set status bit in the raw status register
<b>TSE_DONE</b>	29	w	<b>TSE Measurement Done Interrupt Set</b> 0 <sub>B</sub> no effect 1 <sub>B</sub> set status bit in the raw status register
<b>TSE_HIGH</b>	30	w	<b>TSE Compare High Temperature Interrupt Set</b> 0 <sub>B</sub> no effect 1 <sub>B</sub> set status bit in the raw status register
<b>TSE_LOW</b>	31	w	<b>TSE Compare Low Temperature Interrupt Set</b> 0 <sub>B</sub> no effect 1 <sub>B</sub> set status bit in the raw status register
<b>0</b>	23	r	<b>Reserved</b>

### PASSWD

The PASSWD register is used to control the bit protection scheme.

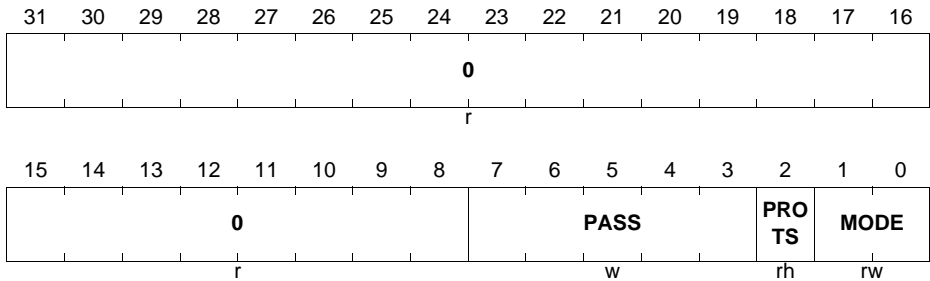
**System Control Unit (SCU)**

**PASSWD**

**Password Register**

**(0024<sub>H</sub>)**

**Reset Value: 0000 0007<sub>H</sub>**



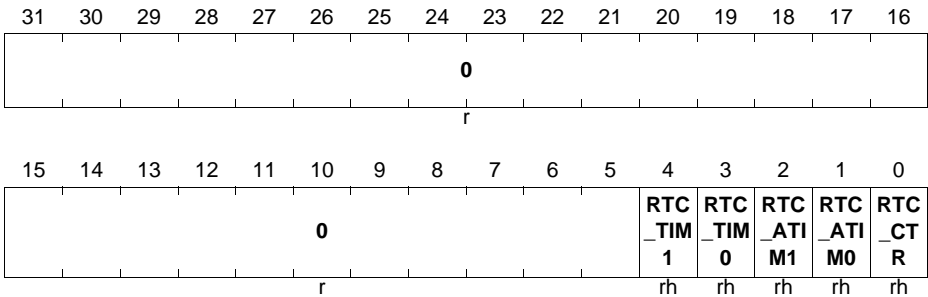
Field	Bits	Type	Description
<b>MODE</b>	[1:0]	rw	<p><b>Bit Protection Scheme Control Bits</b></p> <p>00<sub>B</sub> Scheme disabled - direct access to the protected bits is allowed.</p> <p>11<sub>B</sub> Scheme enabled - the bit field PASS has to be written with the passwords to open and close the access to the protected bits. (Default)</p> <p>Others: Scheme enabled, similar to the setting for MODE = 11<sub>B</sub>.</p> <p>These two bits cannot be written directly. To change the value between 11<sub>B</sub> and 00<sub>B</sub>, the bit field PASS must be written with 11000<sub>B</sub>. Only then will the MODE bit field be registered.</p>
<b>PROTS</b>	2	rh	<p><b>Bit Protection Signal Status Bit</b></p> <p>This bit shows the status of the protection.</p> <p>0<sub>B</sub> Software is able to write to all protected bits.</p> <p>1<sub>B</sub> Software is unable to write to any of the protected bits.</p>
<b>PASS</b>	[7:3]	w	<p><b>Password Bits</b></p> <p>This bit protection scheme only recognizes the following three passwords:</p> <p>11000<sub>B</sub> Enables writing of the bit field MODE.</p> <p>10011<sub>B</sub> Opens access to writing of all protected bits.</p> <p>10101<sub>B</sub> Closes access to writing of all protected bits.</p>
<b>0</b>	[31:8]	r	<b>Reserved</b>

**MIRRSTS**

Mirror status register for control of communication between SCU and RTC.

**MIRRSTS**

**Mirror Update Status Register (0048<sub>H</sub>) Reset Value: 0000 0000<sub>H</sub>**



Field	Bits	Type	Function
RTC_CTR	0	rh	<b>RTC CTR Mirror Register Update Status</b> 0 <sub>B</sub> no update pending 1 <sub>B</sub> update pending
RTC_ATIM0	1	rh	<b>RTC ATIM0 Mirror Register Update Status</b> 0 <sub>B</sub> no update pending 1 <sub>B</sub> update pending
RTC_ATIM1	2	rh	<b>RTC ATIM1 Mirror Register Update Status</b> 0 <sub>B</sub> no update pending 1 <sub>B</sub> update pending
RTC_TIM0	3	rh	<b>RTC TIM0 Mirror Register Update Status</b> 0 <sub>B</sub> no update pending 1 <sub>B</sub> update pending
RTC_TIM1	4	rh	<b>RTC TIM1 Mirror Register Update Status</b> 0 <sub>B</sub> no update pending 1 <sub>B</sub> update pending
0	[31:14]	r	<b>Reserved</b> Read as 0; should be written with 0.

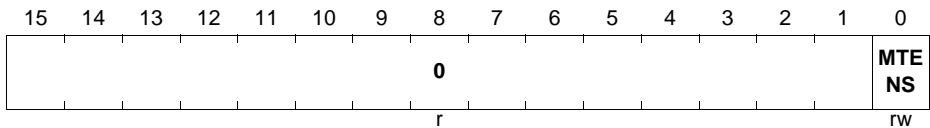
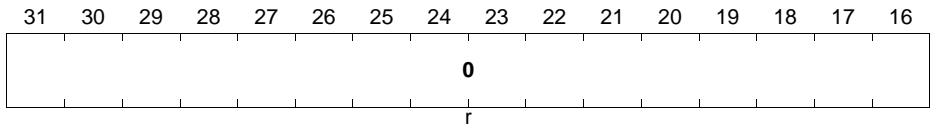
**PMTSR**

This register selects parity test output from a memory instance.

**PMTSR**

**Parity Memory Test Select Register (0054<sub>H</sub>)**

**Reset Value: 0000 0000<sub>H</sub>**



Field	Bits	Type	Description
<b>MTENS</b>	0	rw	<b>Parity Test Enable Control for 16kbytes SRAM</b> Controls the test multiplexer for the 16kbytes SRAM. 0 <sub>B</sub> standard operation 1 <sub>B</sub> generate an inverted parity bit during a write operation
<b>0</b>	31:1]	r	<b>Reserved</b> Should be written with 0.

## **13 Pseudo Random Number Generator**

This chapter describes the Pseudo Random Number Generator (PRNG) module. It contains the following sections:

- **Introduction**
- **Description of Operation Modes**
  - **Key Loading Mode**
  - **Streaming Mode**
  - **Refreshing and Restarting a Random Bit Stream**
- **PRNG Registers**
  - **Data SFRs**
  - **Control SFRs**

### **13.1 Introduction**

The pseudo random bit generator (PRNG) provides random data with fast generation times.

## 13.2 Description of Operation Modes

### 13.2.1 Key Loading Mode

Before the PRNG can be used it has to be initialized by the user software.

The key (seed)  $k$  of the PRNG is a bit string  $k = (k_{n-1}, k_{n-2}, \dots, k_2, k_1, k_0)$  of length  $n$ . A key length of 80 bits is recommended, although smaller or larger key lengths are possible. It is recommended to use chip individual seed values.

The initialization of the PRNG consists of two basic phases:

1. Key loading
2. Warm-up

Key loading is initialized by setting the bit **PRNG\_CTRL.KLD** to "1". In the key loading mode, **PRNG\_WORD** acts always as a 16 bit destination register. The  $p$  partial words  $W_i$  ( $0 \leq i < p$ ) of the key  $k = (W_{p-1}, \dots, W_1, W_0)$ , with  $W_i = (k_{15}, \dots, k_1, k_0)$ , are sequentially written to **PRNG\_WORD** in the order  $W_0, W_1, \dots, W_{p-1}$ . A useful seed size is 80 bits (i.e., 5 data words,  $p=5$ ). Because the bits of the partial key word are sequentially loaded into the internal state of the PRNG, loading of a key word will take 16 clock cycles. The **PRNG\_CHK.RDV** flag is set to "0" while loading is in progress. A flag value of "1" indicates that the next partial key word can be written to **PRNG\_WORD**.

After the complete key has been loaded, the **PRNG\_CTRL.KLD** flag must be set to "0" to prepare the following warm-up phase. This operation takes one clock cycle.

The warm-up phase provides a thorough diffusion of the key bits. For this purpose the user must read and discard 64 random bits from the register **PRNG\_WORD**. The random data output block must be set to either  $b = 8$  or 16 bits. This is achieved by setting the corresponding value of the **PRNG\_CTRL.RDBS** field.

The flag **PRNG\_CHK.RDV** set to "1" indicates that the next random data block of width  $b$  can be read from **PRNG\_WORD**.

If, for any reason, **PRNG\_CTRL.RDBS** is reset to the default value of  $00_B$ , the PRNG must be initialized once more – i.e., a key must be loaded and a warm-up phase carried out.

### 13.2.2 Streaming Mode

The flag **PRNG\_CHK.RDV** set to  $1_B$  indicates that the next random data block can be read from **PRNG\_WORD**. After a word has been read the flag **PRNG\_CHK.RDV** is reset to  $0_B$  by the hardware and generation of new random bits starts. The PRNG requires 17–18 clock cycles to generate a 16 random bits and 9–10 clock cycles to generate eight random bits. From a software point of view it is not necessary to poll the **PRNG\_CHK.RDV** flag. Consecutive read accesses to **PRNG\_WORD** will be delayed automatically by hardware as long as **PRNG\_CHK.RDV** is "0".



## Pseudo Random Number Generator

The width of the output data block is changed by setting the value of **PRNG\_CTRL.RDBS**. This should be done before entering streaming mode, otherwise if the change is made during streaming, the new setting will not come into effect until the next generation cycle is started. The hardware checks that the selected number of bits are available and the flag **PRNG\_CHK.RDV** is set when this condition is true.

In order to avoid reading a duplicate random byte when switching from 8-bit to 16-bit operation mode the last byte generated in the 8-bit mode should first be discarded before switching to 16-bit mode.

*Note: PRNG\_WORD should be accessed as 16 bit register, the upper 16 bits (of a 32 bit access) are ignored on a write and zeroes on a read and therefore contains no random data.*

### 13.2.3 Refreshing and Restarting a Random Bit Stream

The random bit sequence can be refreshed with a new key. In this case the entropy contained in the last internal state is not cleared, but instead the new key is mixed into the current PRNG state. This is referred to as refreshing.

Refreshing is a means of introducing additional entropy into the generation of the random bit sequence. Without refreshing, the entire entropy rests in the initial key (or seed) that was used for initializing the PRNG during first key loading. Thereafter, the generation of the random bit sequence is purely deterministic. The deterministic process is broken whenever refreshing is performed. Refreshing implies that it is not possible to reproduce the same random result using the same key for data generation.

Since the internal state of the PRNG cannot be read and set directly, a sequence cannot be restored from any given state. A random bit sequence based on a certain initial key can, however, be continued. To this means, a segment  $s$  of the output sequence is stored and this segment is used as a initial key later on. The segment  $s = (s_{n-1}, s_{n-2}, \dots, s_2, s_1, s_0)$  of length  $n$  should be fresh – i.e., generated after the last bits used in the application. The length of  $s$  should be at least  $n = 80$  bits. This way a pseudorandom bit sequence can be continued after a system reset without requiring new key material. This process is known as restarting.

*Note: Integration in a multi-application/multitasking environment together with the requirement to obtain a reproducible pseudorandom bit sequence would necessitate a state saving and restoring feature. Hence the OS must be able to save the PRNG state before giving control to application 2 and restore the state before returning control to application 1. This is not possible with the PRNG module.*

### 13.3 Debug Behavior

The PRNG does not support a suspend mode while the system is halted by the debugger. That means that the PRNG continues its operation during debug halt.

**Pseudo Random Number Generator**

### 13.4 PRNG Registers

The interface of the pseudorandom number generator comprises the registers PRNG\_WORD, PRNG\_CHK and PRNG\_CTRL.

**Table 13-1 Registers Address Space**

Module	Base Address	End Address	Note
PRNG	4802 0000 <sub>H</sub>	4802 000F <sub>H</sub>	

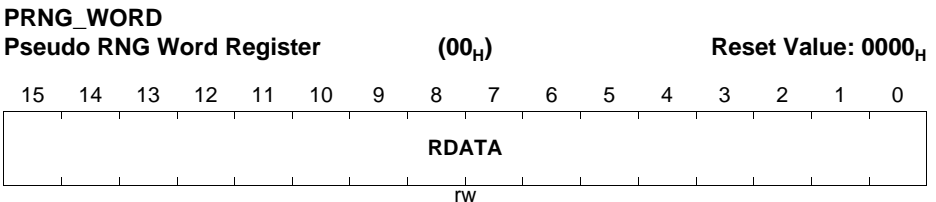
**Table 13-2 Registers Overview**

Register Short Name	Register Long Name	Offset Address	Page Number
<b>PRNG Registers, Data SFRs</b>			
<b>PRNG_WORD</b>	Pseudo RNG word register	00 <sub>H</sub>	<a href="#">Page 13-4</a>
<b>PRNG_CHK</b>	Pseudo RNG status check register	04 <sub>H</sub>	<a href="#">Page 13-5</a>
<b>PRNG Registers, Control SFRs</b>			
<b>PRNG_CTRL</b>	Pseudo RNG control register	0C <sub>H</sub>	<a href="#">Page 13-7</a>

The register is addressed wordwise.

#### 13.4.1 Data SFRs

##### Pseudo RNG Word Register



**Pseudo Random Number Generator**

Field	Bits	Type	Description
<b>RDATA</b>	15:0	rw	<b>Random Data</b> Random bit block or key to load. In the streaming mode the range of valid random bits is defined by the settings given by PRNG_CTRL.RDSB and the value of the flag PRNG_CHK.RDV. In the key loading mode the seed value (key) is written via this register. In this case, the key is written in units of 16 bits.

**Additional Information**

**Notes**

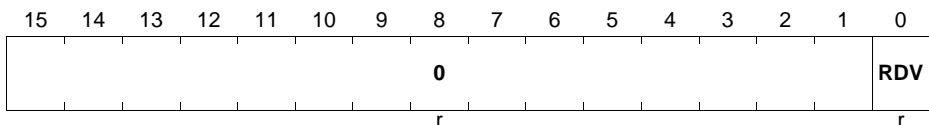
1. Reading PRNG\_WORD while the PRNG is running in key loading mode (configured by setting PRNG\_CTRL.KLD) will return the last value written to the register, whereas write accesses to the register while the PRNG is running in streaming mode (PRNG\_CTRL.KLD = '0') will be ignored.
2. Write access to SFR PRNG\_WORD:  
It is strongly recommended to wait until the SFR bit PRNG\_CHK.RDV indicates that the register PRNG\_WORD is ready to receive (new) data (which will be used to seed the PRNG.)
3. Read access to SFR PRNG\_WORD:  
It is strongly recommended to check the SFR bit PRNG\_CHK.RDV before reading SFR PRNG\_WORD.

**Pseudo RNG Status Check Register**

**PRNG\_CHK**

**Pseudo RNG Status Check Register (04<sub>H</sub>)**

**Reset Value: 0000<sub>H</sub>**



**Pseudo Random Number Generator**

Field	Bits	Type	Description
<b>RDV</b>	0	r	<b>Random Data / Key Valid Flag</b> $0_B$ <b>INV</b> , New random data block is not yet ready to be read. In " <b>Key Loading Mode</b> " on Page 13-2) this flag is set to $0_B$ while loading is in progress. $1_B$ <b>VAL</b> , Random data block is valid. In key loading mode this value indicates that the next partial key word can be written to <b>PRNG_WORD</b> .
<b>0</b>	15:1	r	<b>Reserved</b>

**Additional Information**

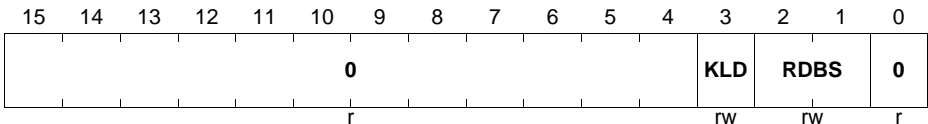
*Note: If a word or byte is read from **PRNG\_WORD** although the data is not ready (**PRNG\_CHK.RDV** =  $0_B$ ), the system stalls until the data becomes ready.*

**Pseudo Random Number Generator**

**13.4.2 Control SFRs**

**Pseudo RNG Control Register**

**PRNG\_CTRL**  
**Pseudo RNG Control Register (0C<sub>H</sub>)** **Reset Value: 0000<sub>H</sub>**



Field	Bits	Type	Description
<b>KLD</b>	3	rw	<b>Key Load Operation Mode</b> 0 <sub>B</sub> <b>STRM</b> , Streaming mode (default) 1 <sub>B</sub> <b>KLD</b> , Key loading mode
<b>RDBS</b>	2:1	rw	<b>Random Data Block Size</b> Set random data block size for read access (16 bits always used for key loading) 00 <sub>B</sub> <b>RES</b> , Reset state (no random data block size defined) <sup>1)</sup> , value of <b>PRNG_WORD</b> is undefined. 01 <sub>B</sub> <b>BYTE</b> , 8 bits in PRNG_WORD.RDATA[7:0] 10 <sub>B</sub> <b>WORD</b> , 16 bits in PRNG_WORD.RDATA[15:0] 11 <sub>B</sub> <b>RFU</b> , Reserved for future use, value of <b>PRNG_WORD</b> is undefined.
<b>0</b>	0	r	<b>Reserved</b>
<b>0</b>	15:4	r	<b>Reserved</b>

1) Once the reset value for RDBS (00<sub>B</sub>) is set, the PRNG must be fully initialized before the functionality can be used. Initialization requires key loading, followed by a warm-up phase.

**Additional Information**

*Note: It is recommended not to change the **PRNG\_CTRL.KLD** flag during key load. Otherwise the distribution of the bits of the PRNG will not be equal.*

# **Communication Peripherals**

## 14 LED and Touch-Sense (LEDTS)

The LED and Touch-Sense (LEDTS) drives LEDs and controls touch pads used as human-machine interface (HMI) in an application.

**Table 14-1 Abbreviations in chapter**

Abbreviation	Meaning
LEDTS	LED and Touch-sense
TSD	time slice duration
TFD	time frame duration
TPD	time period duration

### 14.1 Overview

The LEDTS can measure the capacitance of up to 8 touch pads using the relaxation oscillator (RO) topology. The pad capacitance is measured by generating oscillations on the pad for a fixed time period and counting them. The module can also drive up to 64 LEDs in an LED matrix. Touch pads and LEDs can share pins to minimize the number of pins needed for such applications. This configuration is realized by the module controlling the touch pads and driving the LEDs in a time-division multiplexed manner.

The LEDs in the LED matrix are organized into columns and lines. Every line can be shared between up to 8 LEDs and one touch pad. Certain functions such as column enabling, function selection and control are controlled by hardware. Application software is required to update the LED lines and evaluate the touch pad measurement results.

#### 14.1.1 Features

There are 2 instances of LEDTS kernels. Each kernel has an LED driving function and a touch-sensing function.

For the LED driving function, an LEDTS kernel provides these features:

- Selection of up to 8 LED columns; Up to 7 LED columns if touch-sense function is also enabled
- Configurable active time in LED columns to control LED brightness
- Possibility to drive up to 8 LEDs per column, common-anode or common-cathode
- Shadow activation of line pattern for LED column time slice; LED line patterns are updated synchronously to column activation
- Configurable interrupt enable on selected event
- Line and column pins controlled by port SFR setting

For the touch-sensing function, an LEDTS kernel provides these features:

- Up to 8 touch input lines

**LED and Touch-Sense (LEDTS)**

- Only one pad can be measured at any time; selection of active pad controllable by software or hardware round-robin
- Flexible measurement time on touch pads
- Pin oscillation control circuit with adjustments for oscillation
- 16-bit counter: For counting oscillations on pin.
- Configurable interrupt enable on selected event
- Pin over-rule control for active touch input line (pin)

*Note: This chapter refers to the LED or touch-sense pins, e.g. 'pin COL[x]', 'pin TSIN[x]'. In all instances, it refers to the user-configured pin(s) which selects the LED/touch-sense function. Refer to [Section 14.9.5](#) for more elaboration.*

**Table 14-2 LEDTS Applications**

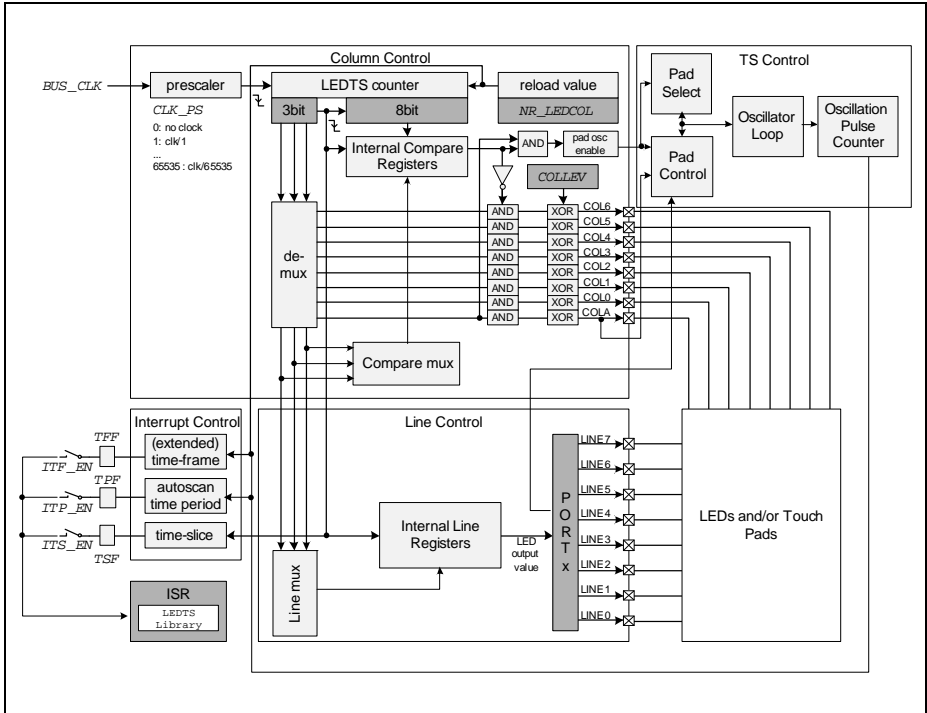
<b>Use Case</b>	<b>Application</b>
Non-mechanical switch	HMI
LED feedback	HMI
Simple PWM	PWM

**14.1.2 Block Diagram**

The LEDTS block diagram is shown in [Figure 14-1](#).



**LED and Touch-Sense (LEDTS)**



**Figure 14-1 LEDTS Block Diagram**

## 14.2 Functional Overview

The same pin can support LED & touch-sense functions in a time-multiplexed manner. LED mode or touch-sense mode can be enabled by hardware for respective function controls.

Time-division multiplexing is done by dividing the time domain into time slots. This basic time slot is called a **time slice**. In one time slice, one LED column is activated or the capacitance of one touch pad is measured.

A **time frame** is composed of 1 or more time slices, up to a maximum of eight. There is one time slice for every LED column enabled. If only LED function is enabled, a time frame can compose up to 8 LED time slices. However, if touch sense function is enabled, the last time slice in every time frame is reserved for touch-sense function. This reduces the maximum number of time slices that can be used for LED function in each time frame to 7. Only one time slice is used for touch sense function in every time frame. This is regardless of the number of touch pads enabled.

In each time slice used for LED function, only one LED column is enabled at a time. In the time slice reserved for touch-sense function, oscillations are enabled and measured on the pin which is activated. No LED column is active during this time slice. A touch pad input line (TSIN[x] pin) is active when its pad turn is enabled. If more than one touch pad input lines are enabled, the enabling and measurement on the touch pads is performed in a round robin manner. Only one touch pad is measured in every time frame.

The resolution of oscillation measurement can be increased by accumulating oscillation counts on each touch input line. When enabled by configuration of "Accumulate Count" (ACCCNT), the pad turn can be extended on consecutive time frames by up to 16 times. This also means that the same touch pad will be measured in consecutive time frames. This control will be handled by hardware. Otherwise it is also possible to enable for software control where the active pad turn is fully under user control.

The number of consecutive time frames, for which a pad turn has been extended, forms an **extended time frame**. When touch-sense function is enabled for automatic hardware pad turn control, several (extended) time frames make up one **autoscan time period** where all pad turns are completed. The time slice duration is configured centrally for the LED and/or touch-sense functions, using the LEDTS-counter. Refer to the description in [Section 14.3](#), [Section 14.9.3](#) and [Figure 14-4](#).

If enabled, a time slice interrupt is triggered on overflow of the 8LSBs of the LEDTS-counter for each new time slice started. The (extended) time frame interrupt may also be enabled. It is triggered on (the configured counts of) overflow of the whole LEDTS-counter. The autoscan time period interrupt may also be enabled. However, this interrupt will require that the hardware pad turn control is enabled. It is triggered when hardware completes the last pad turn on the highest enabled touch input line TSIN[NR\_TSIN].

The column activation and pin oscillation duty cycles can be configured for each time slice. This allows the duration of activation of LED columns and/or touch-sense

---

## **LED and Touch-Sense (LEDTS)**

oscillation counting to be flexible. This is also how the relative brightness of the LEDs can be controlled. In case of touch pads, the activation time is called the oscillation window.

**Figure 14-2** shows an example for a LED matrix configuration with touch pads. The configuration in this example is 8 X 4 LED matrix with 4 touch input lines enabled in sequence by hardware. Here no pad turn is extended by ACCCNT, so four time frames complete an autoscan time period.

In the time slice interrupt, software can:

- set up line pattern for next time slice
- set up compare value for next time slice
- evaluate current function in time slice (especially for analysis/debugging)

Refer to **Section 14.9.1** for **Interpretation of Bit Field FNCOL** to determine the currently active time slice.

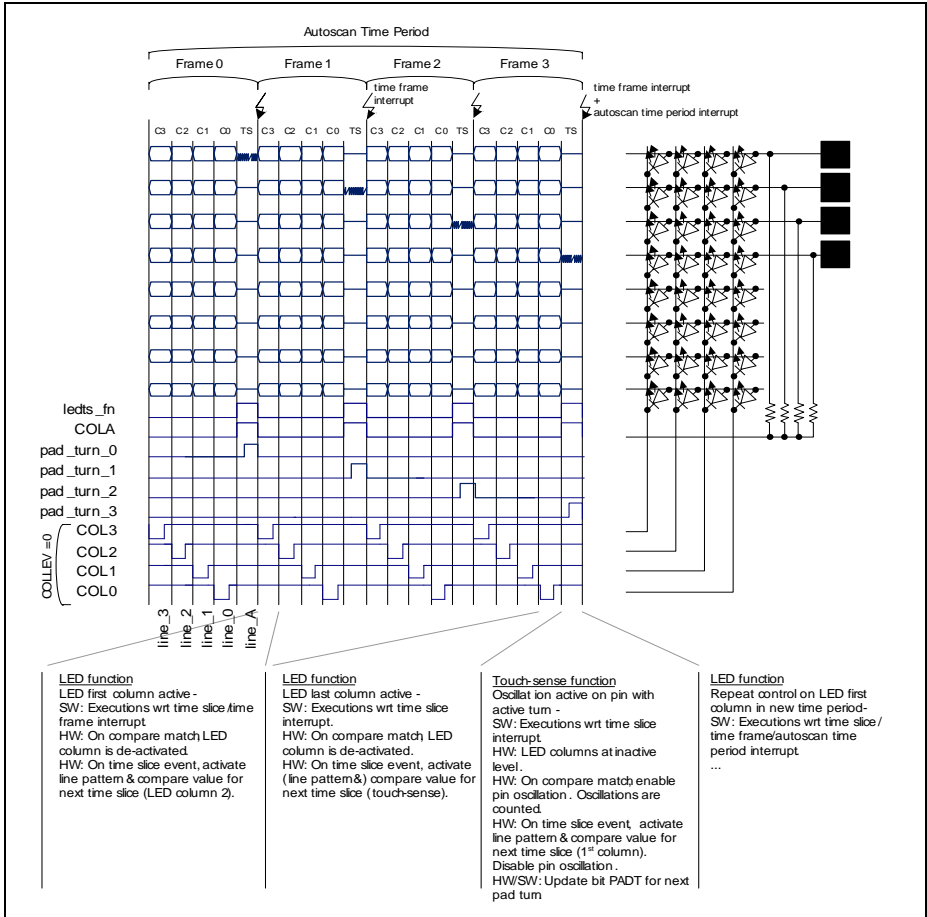
The (extended) time frame interrupt indicates one touch input line TSIN[x] has been sensed (once or number of times in consecutive frames), application-level software can, for example:

- start touch-sense processing (e.g. filtering) routines and update status
- update LED display data to SFR

In the autoscan time period interrupt which indicates all touch-sense input TSIN[x] have been scanned one round, application-level software can:

- evaluate touch detection result & action
- update LED display data to SFR

**LED and Touch-Sense (LEDTS)**



**Figure 14-2 Time-Multiplexed LEDTS Functions on Pin (Example)**

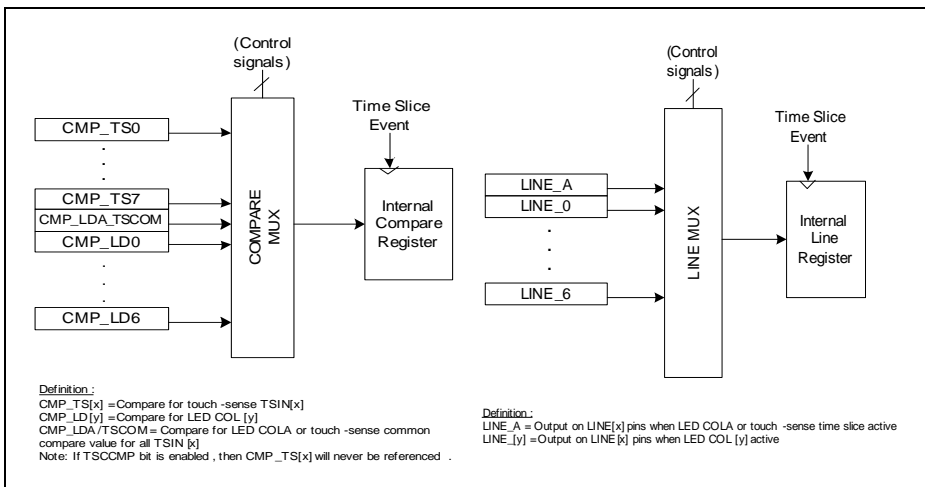
### 14.3 LED Drive Mode

LED driving is supported mainly for LED column selection and line control. At one time, only one column is active. The corresponding line level at high or low determines if the associated LED on column is lit or not. Up to eight columns are supported (if only LED function is enabled), and up to eight LEDs can be controlled per column.

With direct LED drive, adjustment of luminence for different types of LEDs with different forward voltages is supported. A compare register for LEDTS-counter is provided so that the duty cycle for column enabling per time slice can be adjusted. The LED column is enabled from the beginning of the time slice until compare match event. For 100% duty cycle for LED column enable in time slice, the compare value should be set to FFH. If the compare value is set to 00H, the LED column will stay at passive level during the time slice. The internal compare register for each time slice is updated by shadow transfer from their corresponding compare SFR. This takes place automatically at the beginning of each time slice, refer to **Figure 14-3**.

Updating of LED line pattern (LED enabling) per column (time slice) is performed via a similar shadow transfer mechanism, as illustrated in **Figure 14-3**. This shadow transfer of the corresponding line pattern to the internal line SFR takes place automatically at the beginning of each new time slice.

*Note: Any write to any compare or line SFR within the time slice does not affect the internal latched configuration of current time slice.*



**Figure 14-3 Activate Internal Compare/Line Register for New Time Slice**

When the LEDTS-counter is first started (enable input clock by CLK\_PS), a shadow transfer of line pattern and compare value is activated for the first time slice (column).

## LED and Touch-Sense (LEDTS)

A time slice interrupt can be enabled. A new time slice starts on the overflow of the 8LSBs of the LEDTS-counter.

**Figure 14-4** shows the LED function control circuit. This circuit also provides the control for enabling the pad oscillator. A 16-bit divider provides pre-scale possibilities to flexibly configure the internal LEDTS-counter count rate, which overflows in one time frame. During a time frame comprising a configurable number of time slices, the configured number of LED columns are activated in sequence. In the last time slice of the time frame, touch-sense function is activated if enabled.

The LEDTS-counter is started when bit CLK\_PS is set to any value other than 0 and either the LED or touch-sense function is enabled. It does not run when both functions are disabled. To avoid over-write of function enable which disturbs the hardware control during LEDTS-counter running, the TS\_EN and LD\_EN bits can only be modified when bit CLK\_PS = 0. It is nonetheless possible to set the bits TS\_EN and LD\_EN in one single write to SFR **GLOBCTL** when setting CLK\_PS from 0 to 1, or from 1 to 0.

When started, the counter starts running from a reset/reload value based on enabled function(s): 1) the number of columns (bit-field NR\_LEDCOL) when LED function is enabled, 2) add one time slice at end of time frame when touch-sense function is enabled. The counter always counts up and overflows from 7FFH to the reload value which is the same as the reset value. Within each time frame, the sequence of LED column enabling always starts from the most-significant enabled column (column with highest numbering).

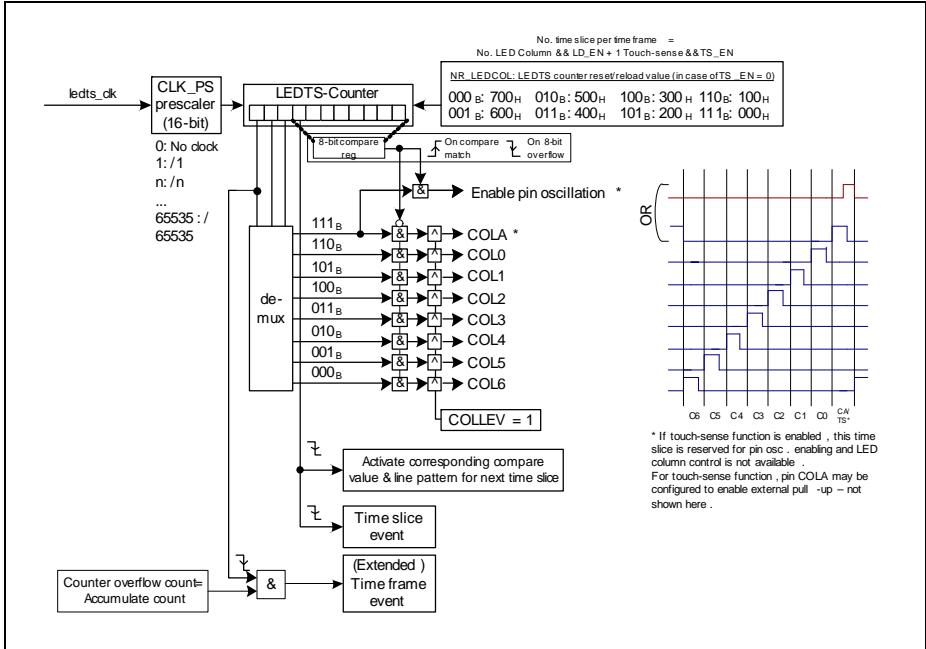
To illustrate this point, in the case of four LED columns and one touch pad input enabled, the column enabling sequence will be in as follows:

- Start with COL3,
- followed by COL2,
- followed by COL1,
- followed by COL0,
- then COLA for touch sense function.

If the touch-sense function is not enabled, COLA will be available for LED function as the last LED column time slice of a time frame. The column enabling sequence will then be as follows:

- Start with COL2,
- followed by COL1,
- followed by COL0,
- then COLA.

**LED and Touch-Sense (LEDTS)**



**Figure 14-4 LED Function Control Circuit (also provides pad oscillator enable)**

In [Section 14.9.3](#), the time slice duration and formulations for LEDTS related timings are provided.

### 14.3.1 LED Pin Assignment and Current Capability

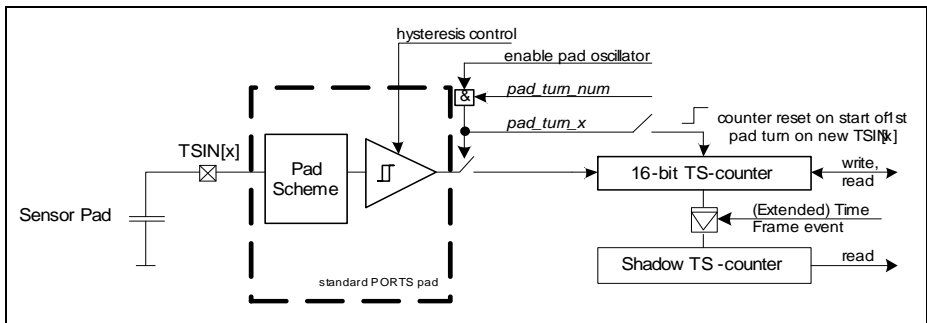
One LED column pin is enabled within each configured time slice duration to control up to eight LEDs at a time. The assignment of COL[x] to pins is configurable to provide options for application pin usage. The current capability of device pins is also a consideration factor for deciding pin assignment to LED function.

The product data-sheet provides data for all I/O parameters relevant to LED drive.

## 14.4 Touch-Sense Mode

**Figure 14-5** shows the pin oscillation control unit, which is integrated with the standard PORTS pad. The active pad turn ( $pad\_turn\_x$ ) for a touch input line is defined as the time duration within the touch-sense time slice (COL A) where the TS-counter is counting oscillations on the TSIN[x] pin. In the case of hardware pad turn control (default), the same TS-counter is connected sequentially on enabled touch input lines to execute a round-robin touch-sensing of TSIN[x] pins.

The pad scheme refers to the pad configuration during the charging and discharging phases of the pad oscillators. There are 2 types of pad schemes available for selection, **Scheme A** (default) and **Scheme B**. These 2 schemes offer a variation for pad oscillation behaviour. In addition to this, there are two types of hysteresis configurations available for the touch input pad which are the standard and large hystereses. These selections can be made via PORTS SFR settings, refer to **Section 14.9.5**.



**Figure 14-5 Touch-Sense Oscillator Control Circuit**

In an example of four touch input lines enabled, the sequence order of touch-sense time slice (COL A) in sequential frames is as follows:

- Always starts with TSIN0,
- followed by TSIN1 in touch-sense time slice of next frame,
- followed by TSIN2 in next touch-sense time slice,
- then TSIN3, and repeat cycle.

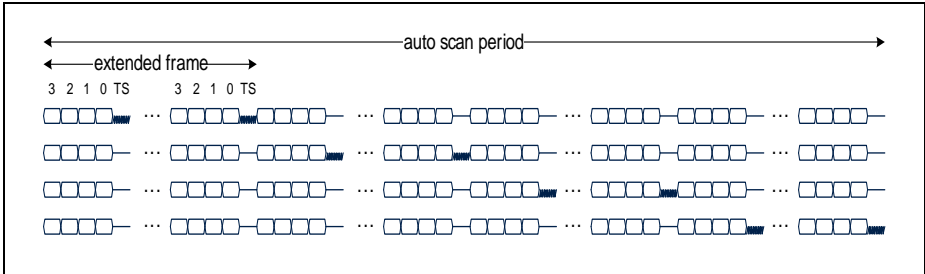
It is possible to enable the touch-sense time slice on the same touch input line for consecutive frames (up to 16 times), to accumulate the oscillation count in TS-counter (see **Figure 14-6**). To illustrate this point, in the same case of four touch input lines enabled, and 2 accumulation counts configured, is as follows:

- Always starts with TSIN0,
- followed by TSIN0 again in touch-sense time slice of next frame,
- followed by TSIN1 in touch-sense time slice of next frame,
- followed by TSIN1 again in touch-sense time slice of next frame,
- followed by TSIN2 in touch-sense time slice of next frame,



**LED and Touch-Sense (LEDTS)**

- followed by TSIN2 again in touch-sense time slice of next frame,
- followed by TSIN3 in touch-sense time slice of next frame,
- then TSIN3 again, and repeat cycle.



**Figure 14-6 Hardware-Controlled Pad Turns for Autoscan of Four TSIN[x] with Extended Frames**

There is a 16-bit TS-counter register and there is a 16-bit shadow TS-counter register. The former is both write- and read-accessible, while the latter is only read-accessible. The actual TS-counter counts the latched number of oscillations and can only be written when there is no active pad turn. The content of the TS-counter is latched to the shadow register on every (extended) time frame event. Reading from the shadow register therefore shows the latest valid oscillation count on one TSIN[x] input, ensuring for the application SW there is at least one time slice duration to get the valid oscillation count and meanwhile the actual TS-counter could continually update due to enabled pin oscillations in current time slice.

The TS-counter and shadow TS-counter have another user-enabled function on (extended) time frame event, which is to validate the counter value differences. When this function is enabled by the user and in case the counter values do not differ by  $2^n$  LSB bits ('n' is configurable), the (extended) time frame interrupt request is gated (no interrupt) and the time frame event flag TFF is not set. This gating is on top of the time frame interrupt enable/disable control.

The TS-counter may be enabled for automatic reset (to  $00_H$ ) on the start of a new pad turn on the next TSIN[x], i.e. resets in the first touch-sense time slice of each (extended) time frame. Bit TSCTROVF indicates that the counter has overflowed. Alternatively, it can be configured such that the TS-counter stops counting in touch-sense time slice(s) of the same extended frame when the count value saturates, i.e. does not overflow & stops at  $FFFF_H$ . In this case, the TS-counter starts running again only in a new (extended) frame on the start of a new pad turn on the next TSIN[x].

The touch-sense function is time-multiplexed with the LED function on enabled LINE[x]/TSIN[x] pins. During the touch-sense time slice for the other TSIN pins which are not on active pad turn, the corresponding LINE[x] output remains active. Software should take care to set the line bits to 1 to avoid current sink from pin COLA.

**LED and Touch-Sense (LEDTS)**

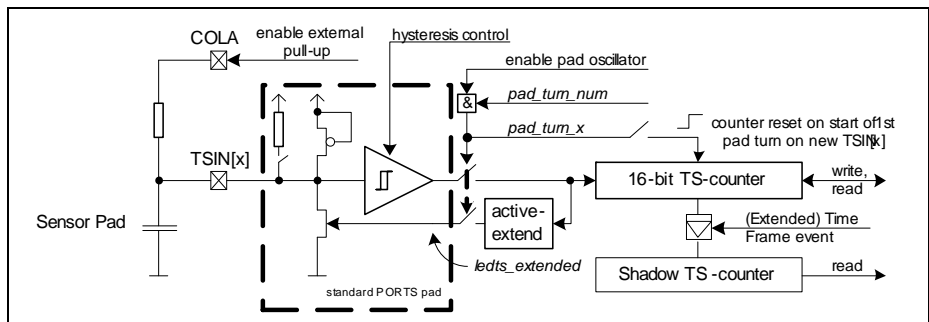
The touch-sense function is active in the last time slice of a time frame. Refer to [Section 14.2](#), and [Section 14.3](#) for more details on time slice allocation and configuration.

The oscillation is enabled on the pin with valid turn for a configurable duration. A compare value provides the means to adjust the duty cycle within the time slice. The pin oscillation is enabled (TS-counter is counting) only on compare match until the end of the time slice. The time interval, in which the TS-counter is counting, is called the oscillation window. For a 100% duty cycle, the compare value has to be set to  $00_H$ . In this case, the oscillation window fills in the entire time slice. Setting the compare value to  $FF_H$  results in no pin oscillation in time slice.

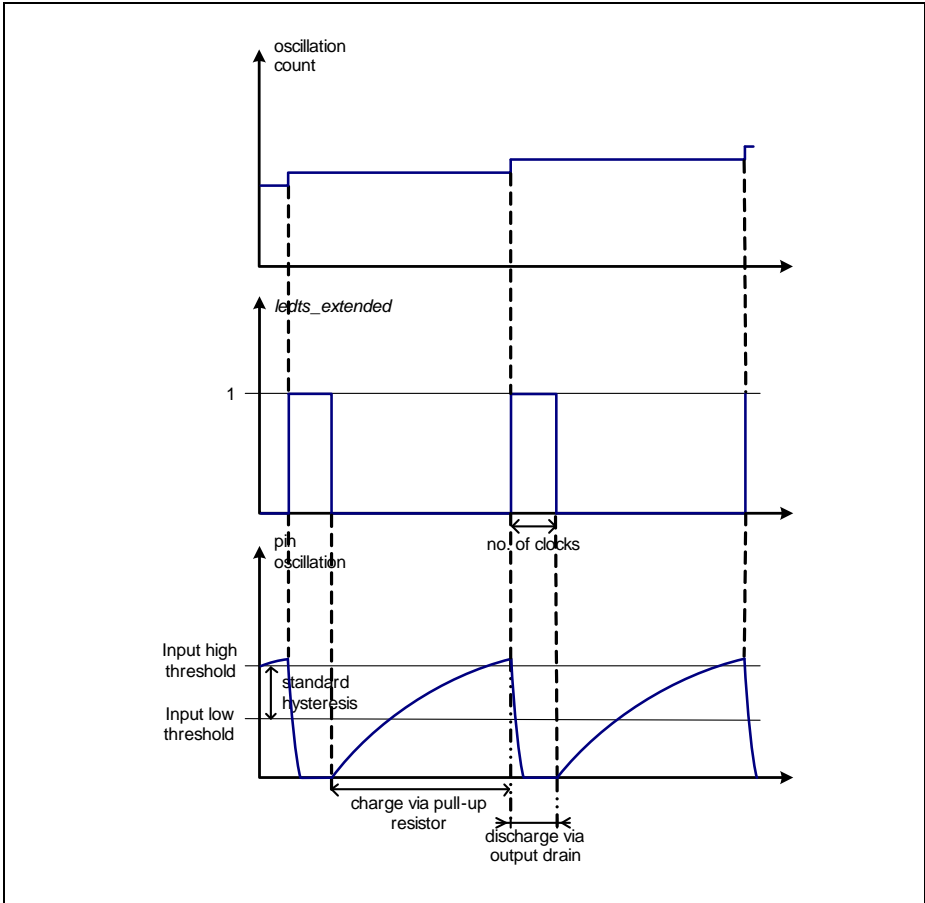
The time slice interrupt, (extended) time frame interrupt and/or autoscan time period interrupt may be enabled as required for touch-sense control.

**Scheme A**

[Figure 14-7](#) provides an illustration of the touch-sense oscillator control circuit in Scheme A. The pad is configured to input mode with weak internal pull-up enabled during the charge phase. The pad is then configured to output mode and the pad is put to output low during the discharge phase. Open drain is always active in this pad scheme. [Figure 14-8](#) shows the pin oscillation profile for this scheme.



**Figure 14-7 Scheme A Touch-Sense Oscillator Control Circuit**



**Figure 14-8 Scheme A Pin Oscillation Profile**

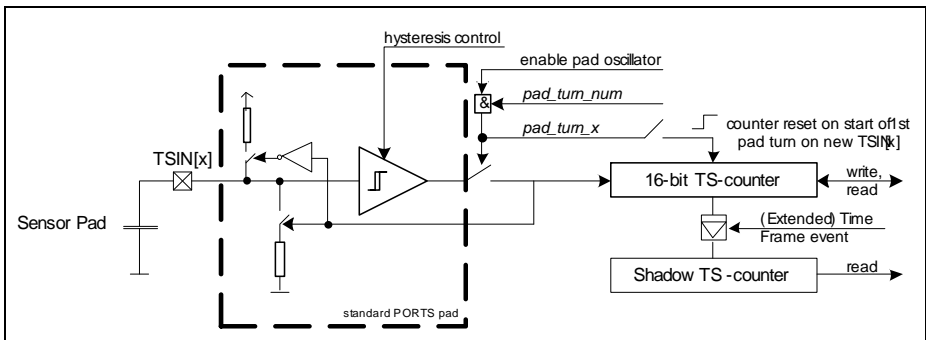
The configuration of the active touch-sense pin TSIN[x] is over-ruled by hardware in the active duration to enable oscillations, reference [Section 14.9.5](#). In particular, the weak internal pull-up enable over-rule can be optionally de-activated (correspondingly internal pull-down disable over-rule is also de-activated; PORTS pin SFR setting for pull applies instead), such as when the user system utilize external resistor for pull-up instead. In the whole duration of the touch-sense time slice, COLA is activated high. This activates a pull-up via an external resistor connected to pin COLA. This configuration provides some flexibility to adjust the pin oscillation rate for adaptation to user system.

**LED and Touch-Sense (LEDTS)**

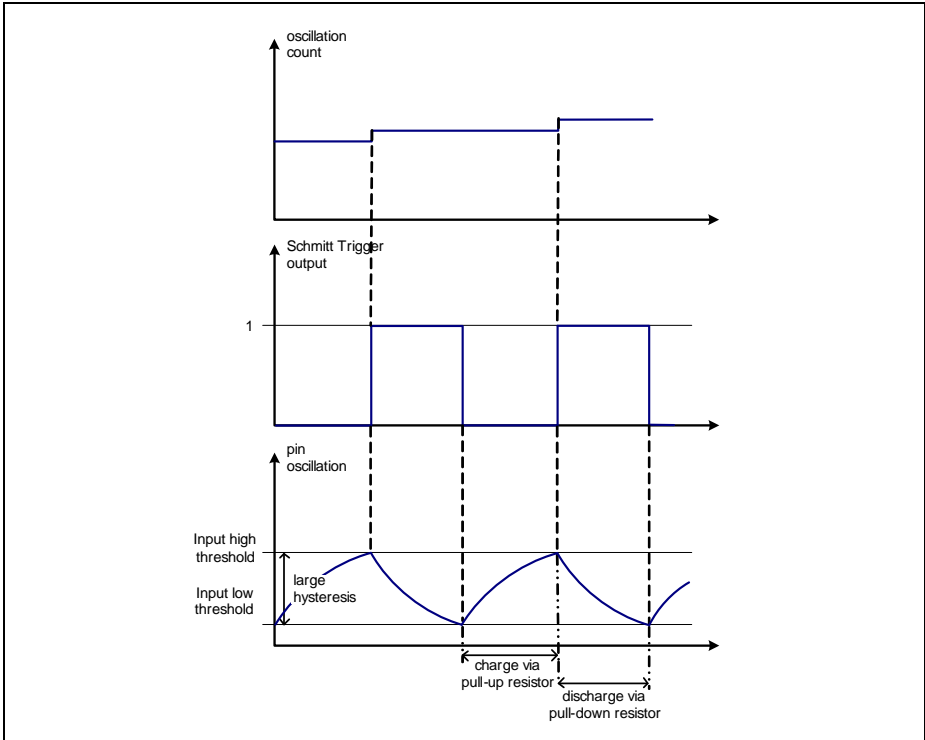
A configurable pin-low-level active extension is provided for adjustment of oscillation per user system. The extension is active during the discharge phase of oscillation (**Figure 14-8**), and can be configured to be extended by a number of peripheral clocks. The register bit field **FNCTL.TSOEXT** determines the duration of the extension. This function is very useful if there is a series resistor between the pin and the touch pad which makes the discharge slower.

**Scheme B**

**Figure 14-9** provides an illustration of the touch-sense oscillator control circuit in Scheme B. The pad is configured to input mode (output disabled) during both charge and discharge phases. The weak internal pull-up is activated during the charge phase. During the discharge phase, pull-down is enabled for the pad. **Figure 14-10** shows the pin oscillation profile for this scheme.



**Figure 14-9 Scheme B Touch-Sense Oscillator Control Circuit**



**Figure 14-10 Scheme B Pin Oscillation Profile**

The configuration of the active touch-sense pin TSIN[x] is over-ruled by hardware in the active duration to enable oscillations, reference [Section 14.9.5](#). However, unlike in [Scheme A](#), the option for an external pull-up over-rule is unavailable. Likewise, the pin-low-level active extension feature is also unavailable.

For this scheme, although 2 types of pad hysteresis configurations are available, it should be noted that only the large hysteresis will be meaningful to use.

### 14.4.1 Finger Sensing

When a finger is placed on the sensor pad, it increases the pin capacitance and frequency of oscillation on pin is reduced. Various factors affect the oscillation frequency including the size of touch pad, ground planes around and below the pad, the material and thickness of the overlay cover, the trace length and the individual pin itself (every pin has a different pull-up resistance).

---

**LED and Touch-Sense (LEDTS)**

In a real-world application, the printed circuit board (PCB) will not be touched directly. Instead, there is usually some sort of a transparent cover material, like a piece of plexiglass sheet, glued onto the PCB. In most of these applications, the oscillation frequency will change by about 2-10% when touched. This change in oscillation frequency can be considered to be very small, and therefore, further signal processing is necessary for reliable detection. Typically, this processing takes the form of a moving average calculation. It is never recommended to try to detect touches based on the raw oscillation count value.

As described in above section, some flexibility is provided to adjust the oscillation frequency in the user system: 1) Configurable pin low-level active extension, 2) Alternative enabling of external pull-up with resistance selectable by user. With a configurable time slice duration, the software can configure the duration of the active pad turn (adjustable within time slice using compare function) and set a count threshold for oscillations to detect if there is a finger touch or not.

To increase touch-sensing oscillation count accuracy, the input clock to LEDTS kernel should be set as high as possible.

## **14.5 Operating both LED Drive and Touch-Sense Modes**

It is possible to enable both LED driving and touch-sense functions in a single time frame. If both functions are enabled, up to 7 time slices are configurable for the LED function, and the last time slice is reserved for touch-sensing function.

The touch-sense function is time-multiplexed with the LED function on enabled LINE[x]/TSIN[x] pins. During the touch-sense time slice (COLA), the corresponding LINE[s] output remains active for the other TSIN pins which are not on active pad turn. In a typical application, COLA is not used and the oscillation is generated by the internal pad structure only. The bits in LINE\_A will determine whether the pads, that are not being measured in the given COLA time slice, have a floating or 0V value. This setting usually has a serious effect on the sensitivity and noise robustness of the touch pads.

Refer to [Section 14.2](#) and [Section 14.3](#) for more details on time slice allocation and configuration.

## 14.6 Service Request Processing

There are three interrupts triggered by LEDTS kernel, all assigned on same node: 1) time slice event, 2) (extended) time frame event, 3) autoscan time period event. The flags are set on event or when CLK\_PS is set from 0 regardless of whether the corresponding interrupt is enabled or not. When enabled, the event (including setting of CLK\_PS from 0) activates the SR0 interrupt request from the kernel.

**Table 14-3** lists the interrupt event sources from the LEDTS, and the corresponding event interrupt enable bit and flag bit.

**Table 14-3 LEDTS Interrupt Events**

Event	Event Interrupt Enable Bit	Event Flag Bit
Start of Time Slice	GLOBCTL.ITS_EN	EVFR.TSF
Start of (Extended) Time Frame <sup>1)</sup>	GLOBCTL.ITF_EN	EVFR.TFF
Start of Autoscan Time Period	GLOBCTL.ITP_EN	EVFR.TPF

1) In case of consecutive pad turns enabled on same TSIN[x] pin by ACCCNT bit-field, interrupt is not triggered on a time frame – but on the extended time frame.

**Table 14-4** shows the interrupt node assignment for each LEDTS interrupt source.

**Table 14-4 LEDTS Events' Interrupt Node Control**

Event	Interrupt Node Enable Bit	Interrupt Node Flag Bit	Node ID
Start of Time Slice: Kernel 0	LEDTS0.SR0	LEDTS0.SR0	29
Start of (Extended) Time Frame: Kernel 0			
Start of Autoscan Time Period: Kernel 0			
Start of Time Slice: Kernel 1	LEDTS1.SR0	LEDTS1.SR0	30
Start of (Extended) Time Frame: Kernel 1			
Start of Autoscan Time Period: Kernel 1			



## 14.7 Debug Behavior

The LEDTS timers/counters LEDTS-counter and TS-counter can be enabled (together) for suspend operation when debug mode becomes active (indicated by HALTED signal from CPU).

At the onset of debug suspend, these counters stop counting (retains the last value) for the duration of the device in debug mode. The function that was active in current time slice on the onset of debug suspend, continues to be active. When debug suspend is revoked, the kernel would resume operation according to latest SFR settings.

*Note: In XMC1200, bit **GLOBCTL.SUSCFG** is reset to its default value by any reset. If suspend function is required during debugging, it is recommended that it is enabled in the user initialization code. Before programming the bit, the module clock has to be enabled and special care needs to be taken while enabling the module clock as described in the CCU (Clock Gating Control) section of the SCU chapter.*

## 14.8 Power, Reset and Clock

The module clock is disabled by default and can be enabled via the SCU\_CGATCLR0 register. Enabling and disabling the module clock could cause a load change and clock blanking could occur as described in the CCU (Clock Gating Control) section of the SCU chapter. It is strongly recommended to setup the module clock in the user initialization code to avoid clock blanking during runtime.

The LEDTS kernel is clocked and accessible on the peripheral bus frequency. User should set up consistent time-slice durations for correct function by ensuring a constant frequency input clock when the kernel is in operation. It is recommended to set the input clock ledts\_clk to highest frequency where possible for optimal touch-sensing accuracy.

Kernel is in operation in active mode except power-down modes where touch-sensing and LED functions are not available.

## 14.9 Initialisation and System Dependencies

This section provides hints for enabling the LEDTS functions and using them.

### 14.9.1 Function Enabling

It is recommended to set up all configuration for the LEDTS in all SFRs before write **GLOBCTL** SFR to enable and start LED and/or touch-sense function(s).

*Note: SFR bits especially affecting the LEDTS-counter configuration for LED/touch-sense function can only be written when the counter is not running i.e. CLK\_PS = 0. Refer to SFR bit description [Section 14.11](#).*

**LED and Touch-Sense (LEDTS)****Enable LED Function Only**

To enable LED function only: set LD\_EN, clear TS\_EN.

Initialization after reset:

```
GLOBCTL = 0bXXXXXXXX XXXXXXXX XXX00000 0000XX10;  
//set LD_EN and start LEDTS-counter on prescaled clock  
//(CLK_PS != 0)
```

Re-configuration during run-time:

```
GLOBCTL &= 0x0000X00X;//stop LEDTS-counter by clearing prescaler  
GLOBCTL = 0bXXXXXXXX XXXXXXXX XXX00000 0000XX10;
```

**Enable Touch-Sense Function Only**

To enable touch-sense function only: clear LD\_EN, set TS\_EN.

Initialization after reset:

```
GLOBCTL = 0bXXXXXXXX XXXXXXXX XXX00000 0000XX01;  
//set TS_EN and start LEDTS-counter on prescaled clock  
//(CLK_PS != 0)
```

Re-configuration during run-time:

```
GLOBCTL &= 0x0000X00X;//stop LEDTS-counter by clearing prescaler  
GLOBCTL = #0bXXXXXXXX XXXXXXXX XXX00000 0000XX01;
```

**Enable Both LED and Touch-Sense Function**

To enable both functions: set LD\_EN, set TS\_EN.

Initialization after reset:

```
GLOBCTL = 0bXXXXXXXX XXXXXXXX XXX00000 0000XX11;  
//set TS_EN and start LEDTS-counter on prescaled clock  
//(CLK_PS != 0)
```

Re-configuration during run-time:

```
GLOBCTL &= 0x0000X00X;//stop LEDTS-counter by clearing prescaler  
GLOBCTL = 0bXXXXXXXX XXXXXXXX XXX00000 0000XX11;
```

**Enable Synchronized Kernel Start (Multiple Kernels)**

Initialization after reset:

```
GLOBCTL = 0bXXXXXXXX XXXXXXXX XXX00000 0000X1XX;  
//set CMTR and start LEDTS-counter on prescaled clock
```

*Note: The slave kernel(s) has to be started first before the master kernel.*

Re-configuration during run-time:

**LED and Touch-Sense (LEDTS)**

```
GLOBCTL &= 0x0000X00X;//stop LEDTS-counter by clearing prescaler
GLOBCTL = 0bXXXXXXXX XXXXXXXX XXX00000 0000X1XX;
```

*Note: The slave kernel(s) has to be started first before the master kernel.*

**Enable Autoscan Time Period Synchronization (Multiple Kernels)**

Initialization after reset:

```
GLOBCTL = 0bXXXXXXXX XXXXXXXX XXX00000 00001XXX;
//set ENSYNC and start LEDTS-counter on prescaled clock
```

*Note: The slave kernel(s) has to be started first before the master kernel.*

Re-configuration during run-time:

```
GLOBCTL &= 0x0000X00X;//stop LEDTS-counter by clearing prescaler
GLOBCTL = 0bXXXXXXXX XXXXXXXX XXX00000 00001XXX;
```

*Note: The slave kernel(s) has to be started first before the master kernel.*

**14.9.2 Interpretation of Bit Field FNCOL**

The interpretation of the FNCOL bit field can be handled by software. The following example where six time slices are enabled (per time frame), with five LED columns and touch-sensing enabled, illustrates this ([Table 14-5](#)).

The FNCOL bit field provides information on the function/column active in the previous time slice. With this information, software can determine the active function/column in current time slice and prepare the necessary values (to be shadow-transferred) valid for the next time slice.

Referring to the example below, when the FNCOL bit field is 111<sub>B</sub>, it can be derived that the touch-sensing function/column was active in the previous time slice and therefore the current active column is LED COL[4]. Hence, the software can update the shadow line and compare registers for LED COL[3] so that these changes will be reflected when LED COL[3] gets activated in the next time slice.

**Table 14-5 Interpretation of FNCOL Bit Field**

<b>FNCOL</b>	<b>Active Function / Column in Current Time Slice</b>	<b>SW Prepare via “Shadow” Registers for Function / Column of Next Time Slice</b>
111 <sub>H</sub>	LED COL[4]	LED COL[3]
010 <sub>H</sub>	LED COL[3]	LED COL[2]
011 <sub>H</sub>	LED COL[2]	LED COL[1]
100 <sub>H</sub>	LED COL[1]	LED COL[0]
101 <sub>H</sub>	LED COL[0]	Touch Input Line TSIN[PADT]
110 <sub>H</sub>	Touch Input Line TSIN[PADT]	LED COL[4]

### 14.9.3 LEDTS Timing Calculations

LEDTS main timing or duration formulation are provided in following.

Count-Rate (CR):

$$CR = (fCLK) \div (PREscaler) \quad (14.1)$$

where fCLK = LEDTS module input clock; PREscaler = **GLOBCTL.CLK\_PS**

Time slice duration (TSD):

$$TSD = 2^8 \div (CR) \quad (14.2)$$

Time frame duration (TFD):

$$TFD = (\text{Number of time slices}) \times TSD \quad (14.3)$$

Extended TFD:

$$\text{ExtendedTFD} = \text{ACCCNT} \times TFD \quad (14.4)$$

where ACCCNT = **FNCTL.ACCCNT**

Autoscan time period duration (TPD):

$$TPD = (\text{Number of touch-sense inputs } TSIN[x]) \times TFD \quad (14.5)$$

LED drive active duration:

$$\text{LED Drive Active Duration} = TSD \times \text{Compare\_VALUE} \div 2^8 \quad (14.6)$$

Touch-sense drive active duration:

$$\text{Touch-sense Drive Active Duration} = TSD \times (2^8 - \text{Compare\_VALUE}) \div 2^8 \quad (14.7)$$

### 14.9.4 Time-Multiplexed LED and Touch-Sense Functions on Pin

Some hints are provided regarding the time-multiplexed usage of a pin for LED and touch-sense function:

- The maximum number of LED columns = 7 when touch-sense function is also enabled.
- If enabled by pin, COLA outputs HIGH to enable external R (resistor) as pull-up for touch-sense function.
- During touch-sense time slice, it is recommended to set LED lines to output LOW.
- During LED time slice, COLA outputs LOW and will sink current if connected lines output HIGH.

**LED and Touch-Sense (LEDTS)**

- The effective capacitance for each TSIN[x] depends largely on what is connected to the pin and the application board layout. All touch-pads for the application should be calibrated for robust touch-detection.

**14.9.5 LEDTS Pin Control**

The user may flexibly assign pins as provided by PORTS SFRs, for the LEDTS functions:

- COL[x] (for LED column control)
- LINE[x] (for LED line control)
- TSIN[x] (for touch-sensing)

Refer also to **Section 14.3** for more considerations with regards to which COL[x] and/or LINE[x]/TSIN[x] will be active based on user configuration.

User code must configure the assigned LED pin PORTS SFR alternate output selection for the LED function, see **Table 14-7** and **Figure 14-11** for **Scheme A**, or **Figure 14-12** for **Scheme B**.

For the touch-sense function, it is also required to configure the PORTS SFRs to enable the hardware function on TSIN[x] pin (similarly alternate output COLA). However, the LEDTS will provide some pin over-rule controls to the assigned touch-sense pin with active pad turn, see **Table 14-7** and **Figure 14-11** for **Scheme A**, or **Figure 14-12** for **Scheme B**. The PORTS SFR Pn\_HWSEL allows selection between 2 types of configurations:

1. Pn\_HWSEL = 01<sub>B</sub>
  - This configures the port pin to output low (strong zero) during the discharging of touch pad.
2. Pn\_HWSEL = 10<sub>B</sub>
  - This configures the port pin to enable pull-down device during the discharging of touch pad.

The PORTS SFR Pn\_PHx allows selection between 2 types of hysteresis configurations:

1. Pn\_PHx = 0XX<sub>B</sub>
  - This sets the pad to standard hysteresis mode.
2. Pn\_PHx = 1XX<sub>B</sub>
  - This sets the pad to large hysteresis mode.

From these pad and hysteresis configurations available, a total of 4 different combinations can be derived (**Table 14-6**).

**Table 14-6 Combinations of pad and hysteresis configurations**

	<b>Pad Configuration</b>	<b>Hysteresis Configuration</b>
Combination 1	Output mode (output low)	Standard
Combination 2	Output mode (output low)	Large

**LED and Touch-Sense (LEDTS)**

**Table 14-6 Combinations of pad and hysteresis configurations**

	<b>Pad Configuration</b>	<b>Hysteresis Configuration</b>
Combination 3 <sup>1)</sup>	Input mode (pull-down enabled)	Standard
Combination 4	Input mode (pull-down enabled)	Large

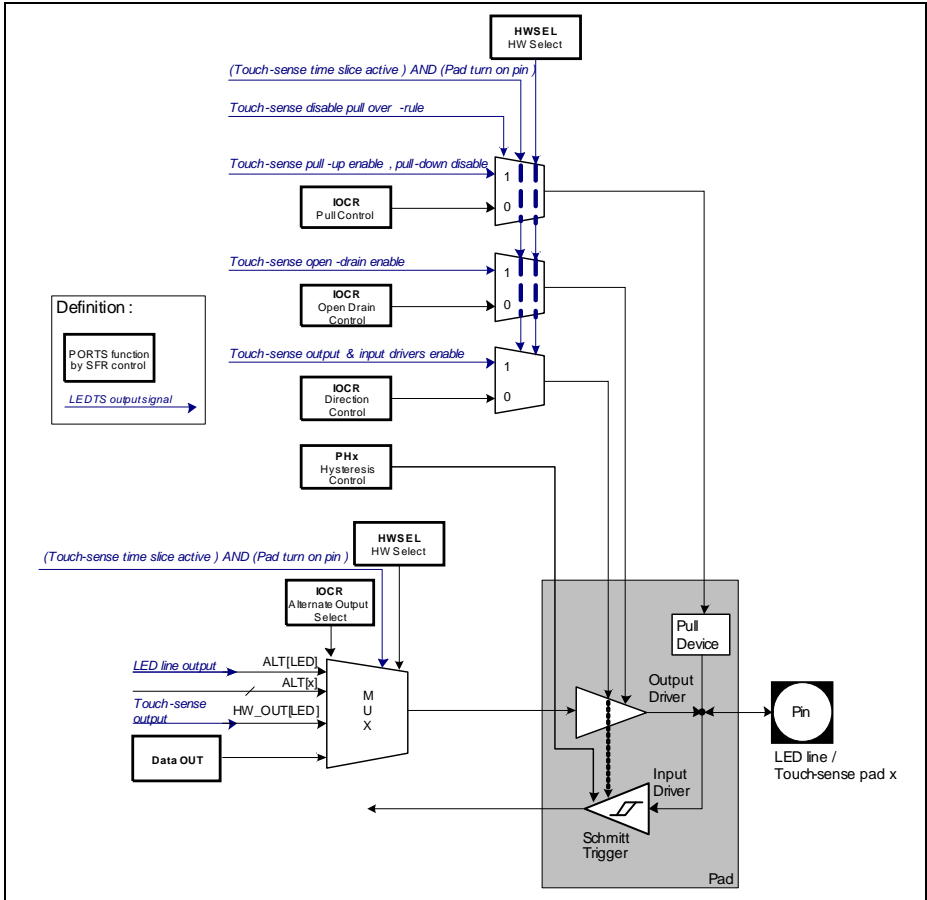
1) It can be noted that it is meaningless to use this combination due to the slower charge and discharge speed.

**Table 14-7 LEDTS Pin Control Signals**

<b>Function</b>	<b>ld/ts_en</b>	<b>ledts_fn</b>	<b>Pin</b>	<b>Control of Assigned Pin</b>
LED column	LD_EN = 1	0 = LED	Enable COL[x]; Passive level on COL[the rest]. If TS_EN = 1, COLA = 0.	PORTS SFR setting
LED line	LD_EN = 1	0 = LED	LINE[x] = internal line register value latched from bit field LINE_[x]	PORTS SFR setting
Touch-sense	TS_EN = 1	1 = Touch-sense	Enable TSIN[x] for oscillation. All other TSIN pins output line value.  Passive level on COL[the rest] except COLA = 1.	Hardware over-rule on pad_turn_x <sup>1)</sup> for active duration: <b><u>Scheme A (default)</u></b> - Enable pull-up, disable pull-down (pull over-rule can be disabled by bit EPULL) - Set to output mode (both input, output stages enabled) - Enable open-drain <b><u>Scheme B</u></b> - Pull-up, pull-down controlled by pad input driver signal (EPULL option disabled for this scheme) - Set to input mode (input stage enabled, output stage disabled) - Disable open-drain

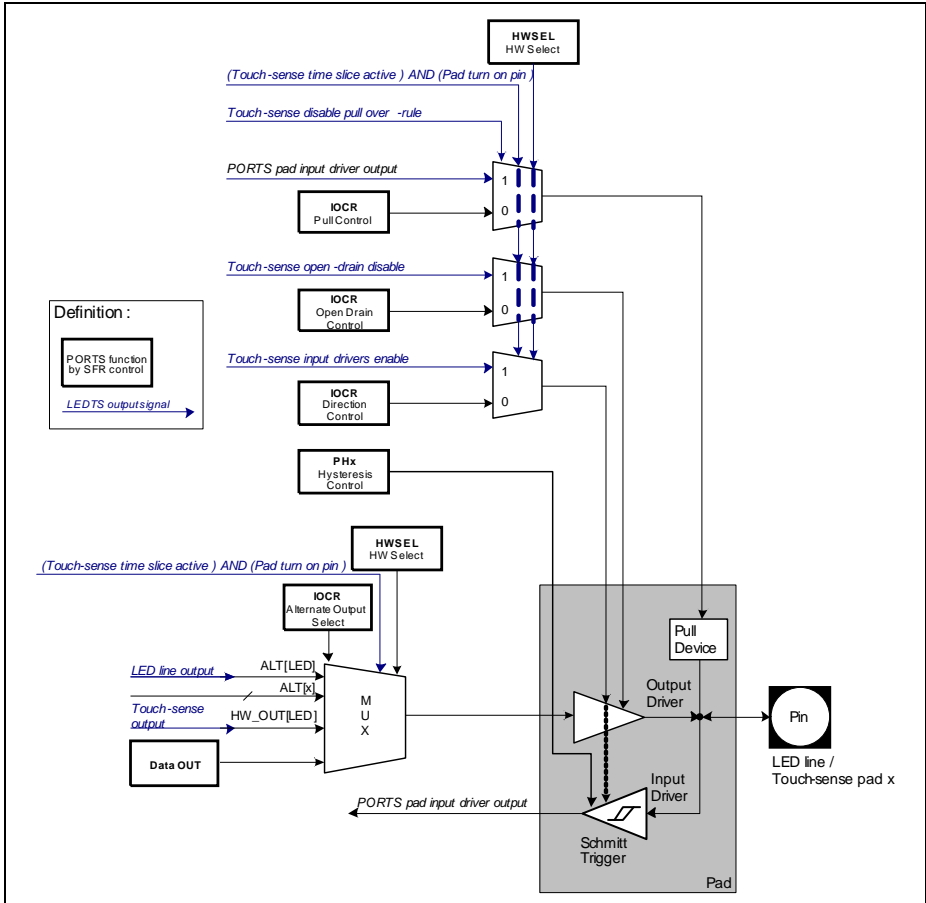
1) For the other pad inputs not on turn, there is no HW over-rule which means the PORTS SFR setting is active.

**LED and Touch-Sense (LEDTS)**



**Figure 14-11 Over-rule Control on Pin for Touch-Sense Function (Scheme A)**

**LED and Touch-Sense (LEDTS)**



**Figure 14-12 Over-rule Control on Pin for Touch-Sense Function (Scheme B)**

**14.9.6 Software Hints**

This section provides some useful software hints:

- Compare value 00<sub>H</sub> enables oscillation for the full duration of the time slice, whereas FF<sub>H</sub> disables oscillation.
- In order to maximize the resolution of the oscillation window, compare value should be selected to maximize the oscillation count without overflowing the TS-counter.
- Valid pad detection period (the time required to detect a valid touch on a pad) can be extended by:



## LED and Touch-Sense (LEDTS)

- enabling dummy LED columns (without assigning/setting the LED column pins)
- selecting bigger pre-scale factor (**GLOBCTL.CLK\_PS**)
- accumulating the number of pad oscillations (**FNCTL.ACCCNT**)
- Valid pad detection period can be reduced by:
  - selecting smaller pre-scale factor (**GLOBCTL.CLK\_PS**)
  - reducing the number of accumulations for pad oscillations (**FNCTL.ACCCNT**)
- When using multiple kernels, and slave kernel is taking its clock from the master, it is recommended to start the slave kernel first (by writing to its **GLOBCTL.CLK\_PS** bit field to a non-zero value) before the master kernel.
- Clock blanking and  $V_{DDP}$  fluctuations may affect the pad oscillation, which will be reflected by the oscillator counter value at **TSVAL**. A software workaround may be required.

### 14.9.7 Hardware Design Hints

This section provides some hardware design hints:

- Touch button oscillation frequency changes when the value of the external pull-up resistor (connected to COLA pin) changes. This results in different sensitivity of the touch button as well as the crosstalk between the adjacent touch buttons.
  - A suitable pull-up resistor should be selected to balance the sensitivity of the touch button and the accuracy of the detection.
- The presence of LEDs modifies the equivalent capacitance for a touch pad. A larger number of LEDs connected to a touch pad will increase the self-capacitance of the pad. This makes the pad less sensitive.
- If possible, LEDs should be located near to the touch pads, to reduce the additional parasitic capacitance introduced by the traces.

### 14.10 Multiple Kernels Usage and Synchronization

A single LEDTS kernel comprises of control and status for:

- Up to 8 time slices per time frame (equivalent to max. 8 LED columns, or 7 if touch-sense is enabled)
- Up to 8 LED lines per column
- Up to 8 touch-sense inputs

A kernel therefore provides on up to 16 pins, to drive maximum 64 LEDs or lesser in combination with touch-sense function on up to 8 touch-sense inputs that can possibly be extended to support more than 8 touchpads such as to implement dual-pad which is effectively a single touchpad connected on two touch-sense inputs (refer to **Figure 14-2**).

Some products implement multiple instances of the LEDTS kernel, and can therefore drive even more LEDs and sense more touchpads. Synchronization amongst the kernels

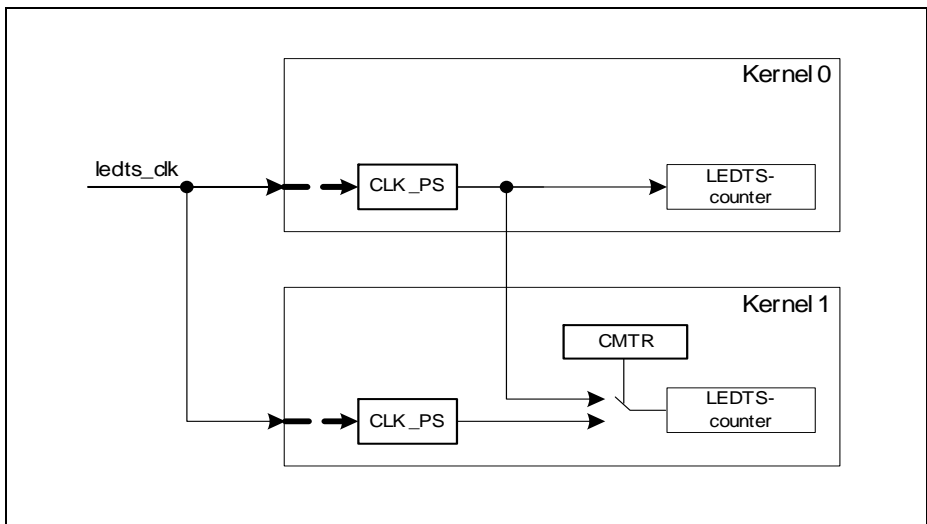
**LED and Touch-Sense (LEDTS)**

is supported on hardware for synchronized start of LEDTS-counters on same clock setting and in the aspect to simplify touch-sensing analysis handling by software.

In case of LED driving across kernels, it is advised to balance the number of LED time slices amongst the kernels to optimize the display synchronization.

**Synchronized Start of Kernels**

Every kernel has a control bit CMTR which defines if the kernel is a master or slave with respect to LEDTS-counter clock control. A kernel defined as clock master generates its own LEDTS-counter clock based on input clock and corresponding SFR bit setting CLK\_PS in its GLOBCTL register. A kernel defined as clock slave ignores the setting of clock configuration in its own SFR and instead, its counter directly takes the clock provided by Kernel0. Regardless of CMTR setting, Kernel0 always takes its own generated clock based on its own SFR setting. The synchronized start of kernels is illustrated in **Figure 14-13**.



**Figure 14-13 Synchronized Kernel Start Options (Example with 2 Kernels)**

**Synchronization On Enabled Autoscan Time Period**

When touch-sensing function is enabled, synchronization among kernels on enabled autoscan time period can be enabled to simplify software handling for touch-sensing analysis for touch detection & action. To “enable autoscan time period”, it is necessary to enable the hardware pad turn control. When software pad turn control is enabled instead, no synchronization is handled by hardware.

**LED and Touch-Sense (LEDTS)**

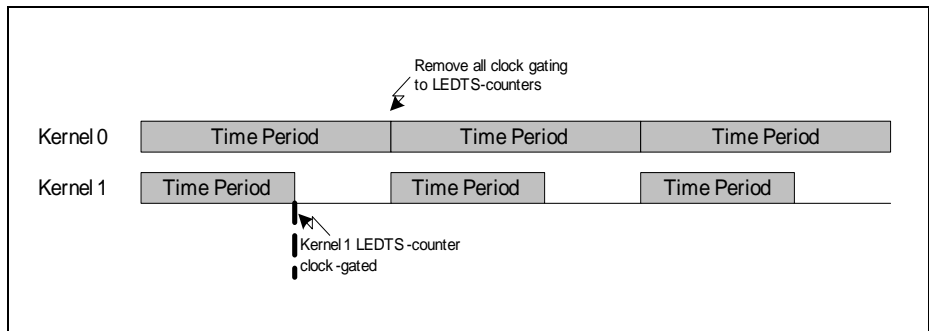
The synchronization is achieved on Kernel0's autoscan time period. This means Kernel0 must be enabled and configured such that it has the longer/longest autoscan time period duration (TPD). All other kernels enabled for the synchronization (bit ENSYNC) will have its respective LEDTS-counter clock gated (no progress to new time slices) upon autoscan time period event of the kernel. Only upon Kernel0 autoscan time period event, all the clock gating are removed and all synchronized kernels continue progressing on time slices. This mechanism is illustrated on **Figure 14-14**.

To summarize, kernels synchronization for touch-sensing on enabled autoscan time period is possible/useful only when the following conditions are met:

- touch-sense function is enabled on all kernels
- hardware pad turn control is enabled on all kernels
- Kernel0 is enabled and has the longer/longest TPD
- all respective kernels have its LEDTS-counter running on clock output from Kernel0

When using this synchronization feature, the **GLOBCTL.CLK\_PS** bit field for the slave kernels have to be set to a non-zero value before setting the **GLOBCTL.CLK\_PS** bit field for the master kernel (Kernel0). If Kernel0 is started first before the slave kernels, the slave kernels will not run in the first autoscan time period. Instead, the slaves will wait for the onset of Kernel0's autoscan time period before running i.e. from second autoscan time period onwards.

Synchronization on enabled autoscan time period allows touch-sense software to evaluate only once, after all touchpads have been sensed across all kernels. Based on the result of touch detection across all these respective touchpads, software can then evaluate the actual touch status and react accordingly.



**Figure 14-14 Illustration of Synchronization on Enabled Autoscan Time Period**

## 14.11 Registers

### Registers Overview

The absolute register address is calculated by adding:  
Module Base Address + Offset Address

**Table 14-8 Registers Address Space**

Module	Base Address	End Address	Note
LEDTS0	5002 0000 <sub>H</sub>	5002 002B <sub>H</sub>	
LEDTS1	5002 0400 <sub>H</sub>	5002 042B <sub>H</sub>	

The prefix “**LEDTSx\_**” is added to the register names in this table to indicate they belong to the LEDTS kernel. In this naming convention, x indicates the kernel number (e.g. LEDTS0\_ for the LEDTS0 kernel and “LEDTS1\_” for the LEDTS1 kernel).

Access rights within the address range of an LEDTS kernel:

- Read or write access to defined register addresses: U, PV
- Accesses to empty addresses: nBE

**Table 14-9 Register Overview of LEDTS**

Short Name	Description	Offset Addr.	Access Mode		Description See
			Read	Write	
ID	Module Identification Register	0000 <sub>H</sub>	U, PV	U, PV	<a href="#">Page 14-31</a>
GLOBCTL	Global Control Register	0004 <sub>H</sub>	U, PV	U, PV	<a href="#">Page 14-32</a>
FNCTL	Function Control Register	0008 <sub>H</sub>	U, PV	U, PV	<a href="#">Page 14-34</a>
EVFR	Event Flag Register	000C <sub>H</sub>	U, PV	U, PV	<a href="#">Page 14-37</a>
TSVAL	Touch-Sense TS-Counter Value	0010 <sub>H</sub>	U, PV	U, PV	<a href="#">Page 14-39</a>
LINE0	Line Pattern Register 0	0014 <sub>H</sub>	U, PV	U, PV	<a href="#">Page 14-40</a>
LINE1	Line Pattern Register 1	0018 <sub>H</sub>	U, PV	U, PV	<a href="#">Page 14-40</a>
LDCMP0	LED Compare Register 0	001C <sub>H</sub>	U, PV	U, PV	<a href="#">Page 14-41</a>
LDCMP1	LED Compare Register 1	0020 <sub>H</sub>	U, PV	U, PV	<a href="#">Page 14-42</a>
TSCMP0	Touch-Sense Compare Register 0	0024 <sub>H</sub>	U, PV	U, PV	<a href="#">Page 14-43</a>

**LED and Touch-Sense (LEDTS)**

**Table 14-9 Register Overview of LEDTS**

Short Name	Description	Offset Addr.	Access Mode		Description See
			Read	Write	
TSCMP1	Touch-Sense Compare Register 1	0028 <sub>H</sub>	U, PV	U, PV	<a href="#">Page 14-43</a>
Reserved	Reserved	002C <sub>H</sub> - 1FFC <sub>H</sub>	nBE	nBE	

**14.11.1 Registers Description**

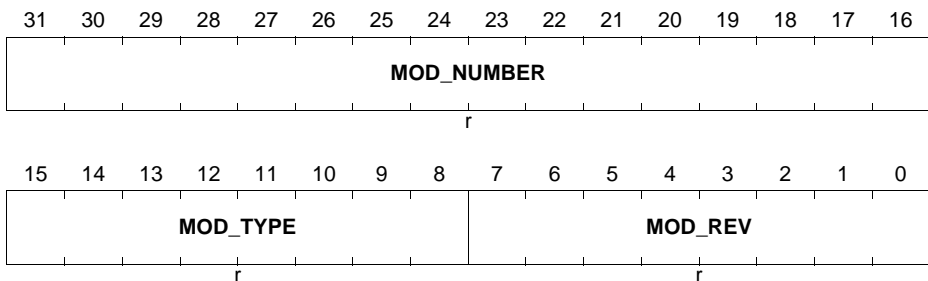
The LEDTS SFRs are organized into registers for global initialization control, functional control comprising TS-counter value, line pattern and compare value registers.

**LEDTSx\_ID**

The module identification register indicate the function and the design step of the peripheral.

**ID**

**Module Identification Register (00<sub>H</sub>)** Reset Value: 00AB C0XX<sub>H</sub>



Field	Bits	Type	Description
MOD_REV	[7:0]	r	<b>Module Revision Number</b> MOD_REV defines the revision number. The value of a module revision starts with a 01 <sub>H</sub> (first revision).
MOD_TYPE	[15:8]	r	<b>Module Type</b> This bit field is C0 <sub>H</sub> . It defines the module as a 32-bit module.

**LED and Touch-Sense (LEDTS)**

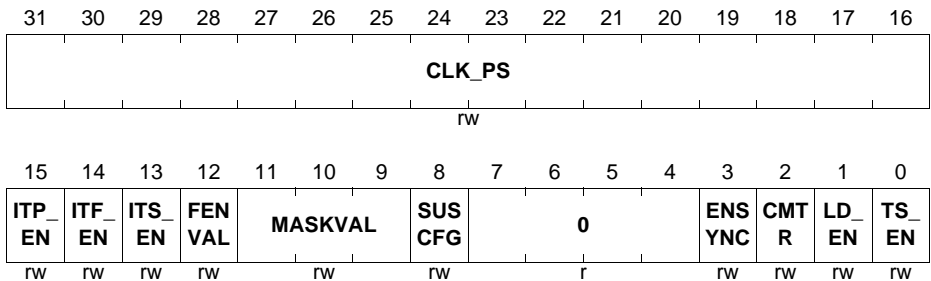
Field	Bits	Type	Description
<b>MOD_NUMBER</b>	[31:16]	r	<b>Module Number Value</b> This bit field defines the module identification number.

**GLOBCTL**

The GLOBCTL register is used to initialize the LEDTS global controls.

**GLOBCTL**

**Global Control Register (04<sub>H</sub>)**      **Reset Value: 0000 0000<sub>H</sub>**



Field	Bits	Type	Description
<b>TS_EN<sup>1)</sup></b>	0	rw	<b>Touch-Sense Function Enable</b> Set to enable the kernel for touch-sense function control when CLK_PS is set from 0.
<b>LD_EN<sup>1)</sup></b>	1	rw	<b>LED Function Enable</b> Set to enable the kernel for LED function control when CLK_PS is set from 0.
<b>CMTR<sup>1)</sup></b>	2	rw	<b>Clock Master Disable</b> 0 <sub>B</sub> Kernel generates its own clock for LEDTS-counter based on SFR setting 1 <sub>B</sub> LEDTS-counter takes its clock from another master kernel If this bit is set, the bit field <b>GLOBCTL.CLK_PS</b> needs to be set to a non-zero value to activate the kernel, even though it is taking its clock from the master kernel.

**LED and Touch-Sense (LEDTS)**

Field	Bits	Type	Description
<b>ENSYNC<sup>1)</sup></b>	3	rw	<b>Enable Autoscan Time Period Synchronization</b> 0 <sub>B</sub> No synchronization 1 <sub>B</sub> Synchronization enabled on Kernel0 autoscan time period
<b>SUSCFG</b>	8	rw	<b>Suspend Request Configuration</b> 0 <sub>B</sub> Ignore suspend request 1 <sub>B</sub> Enable suspend according to request
<b>MASKVAL</b>	[11:9]	rw	<b>Mask Number of LSB Bits for Event Validation</b> This defines the number of LSB bits to mask for TS-counter and shadow TS-counter comparison when Time Frame validation is enabled. 0 <sub>D</sub> Mask LSB bit 1 <sub>D</sub> Mask 2 LSB bits ... 7 <sub>D</sub> Mask 8 LSB bits
<b>FENVAL</b>	12	rw	<b>Enable (Extended) Time Frame Validation</b> When enabled, TS-counter and shadow TS-counter values are compared to validate a Time Frame event for set flag and interrupt request. When validation fail, TFF flag does not get set and interrupt is not requested. 0 <sub>B</sub> Disable 1 <sub>B</sub> Enable
<b>ITS_EN</b>	13	rw	<b>Enable Time Slice Interrupt</b> 0 <sub>B</sub> Disable 1 <sub>B</sub> Enable
<b>ITF_EN</b>	14	rw	<b>Enable (Extended) Time Frame Interrupt</b> 0 <sub>B</sub> Disable 1 <sub>B</sub> Enable
<b>ITP_EN</b>	15	rw	<b>Enable Autoscan Time Period Interrupt</b> 0 <sub>B</sub> Disable 1 <sub>B</sub> Enable (valid only for case of hardware-enabled pad turn control)

**LED and Touch-Sense (LEDTS)**

Field	Bits	Type	Description
<b>CLK_PS</b>	[31:16]	rw	<p><b>LEDTS-Counter Clock Pre-Scale Factor</b> The constant clock input is prescaled according to setting.</p> <p>0<sub>D</sub> No clock 1<sub>D</sub> Divide by 1 ... 65535<sub>D</sub> Divide by 65535</p> <p>This bit can only be set to any other value (from 0) provided at least one of touch-sense or LED function is enabled. The LEDTS-counter starts running on the input clock from reset/reload value based on enabled function(s) (and NR_LEDCOL). Refer <a href="#">Section 14.3</a> for details.</p> <p>When this bit is clear to 0 from other value, the LEDTS-counter stops running and resets.</p>
<b>0</b>	[7:4]	r	<p><b>Reserved</b> Read as 0; should be written with 0.</p>

1) This bit can only be modified when bit CLK\_PS = 0.

**FNCTL**

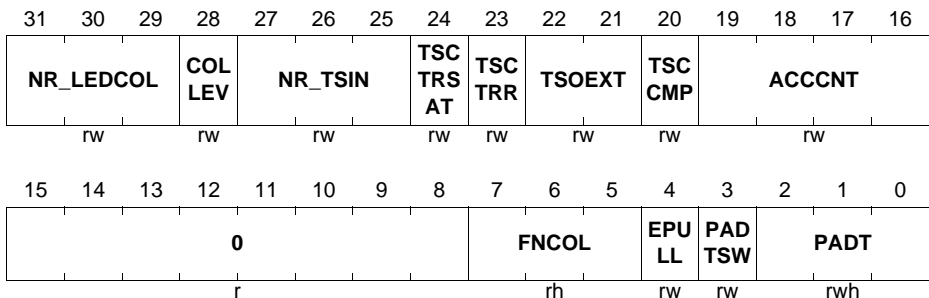
The FNCTL control register provides control bits for the LED and Touch Sense functions.

**FNCTL**

**Function Control Register**

**(08<sub>H</sub>)**

**Reset Value: 0000 0000<sub>H</sub>**





**LED and Touch-Sense (LEDTS)**

Field	Bits	Type	Description
<b>PADT</b>	[2:0]	rw	<p><b>Touch-Sense TSIN Pad Turn</b></p> <p>This is the TSIN[x] pin that is next or currently active in pad turn. When PADTSW = 0, the value is updated by hardware at the end of touch-sense time slice. Software write is always possible.</p> <p>0<sub>D</sub> TSIN0 ... 7<sub>D</sub> TSIN7</p>
<b>PADTSW<sup>1)</sup></b>	3	rw	<p><b>Software Control for Touch-Sense Pad Turn</b></p> <p>0<sub>B</sub> The hardware automatically enables the touch-sense inputs in sequence round-robin, starting from TSIN0.</p> <p>1<sub>B</sub> Disable hardware control for software control only. The touch-sense input is configured in bit PADT.</p>
<b>EPULL</b>	4	rw	<p><b>Enable External Pull-up Configuration on Pin COLA</b></p> <p>When set, the internal pull-up over-rule on active touch-sense input pin is disabled.</p> <p>0<sub>B</sub> HW over-rule to enable internal pull-up is active on TSIN[x] for set duration in touch-sense time slice. With this setting, it is not specified to assign the COLA to any pin.</p> <p>1<sub>B</sub> Enable external pull-up: Output 1 on pin COLA for whole duration of touch-sense time slice.</p> <p><i>Note: Independent of this setting, COLA always outputs 1 for whole duration of touch-sense time slice.</i></p>
<b>FNCOL</b>	[7:5]	rh	<p><b>Previous Active Function/LED Column Status</b></p> <p>Shows the active function / LED column in the previous time slice. Updated on start of new time-slice when LEDTS-counter 8LSB over-flows. Controlled by latched value of the internal DE-MUX, see <a href="#">Figure 14-4</a>.</p>

**LED and Touch-Sense (LEDTS)**

Field	Bits	Type	Description
ACCNT <sup>1)</sup>	[19:16]	rw	<p><b>Accumulate Count on Touch-Sense Input</b> Defines the number of times a touch-sense input/pin is enabled in touch-sense time slice of consecutive frames. This provides to accumulate oscillation count on the TSIN[x].</p> <p>0<sub>D</sub> 1 time 1<sub>D</sub> 2 times ... 15<sub>D</sub> 16 times</p>
TSCCMP	20	rw	<p><b>Common Compare Enable for Touch-Sense</b> 0<sub>B</sub> Disable common compare for touch-sense 1<sub>B</sub> Enable common compare for touch-sense</p>
TSOEXT	[22:21]	rw	<p><b>Extension for Touch-Sense Output for Pin-Low-Level</b> 00<sub>B</sub> Extend by 1 ledts_clk 01<sub>B</sub> Extend by 4 ledts_clk 10<sub>B</sub> Extend by 8 ledts_clk 11<sub>B</sub> Extend by 16 ledts_clk</p>
TSCTRR	23	rw	<p><b>TS-Counter Auto Reset</b> 0<sub>B</sub> Disable TS-counter automatic reset 1<sub>B</sub> Enable TS-counter automatic reset to 00H on the first pad turn of a new TSIN[x]. Triggered on compare match in time slice.</p>
TSCTRSAT	24	rw	<p><b>Saturation of TS-Counter</b> 0<sub>B</sub> Disable 1<sub>B</sub> Enable. TS-counter stops counting in the touch-sense time slice(s) of the same (extended) frame when it reaches FFH. Counter starts to count again on the first pad turn of a new TSIN[x], triggered on compare match.</p>
NR_TSIN <sup>1)</sup>	[27:25]	rw	<p><b>Number of Touch-Sense Input</b> Defines the number of touch-sense inputs TSIN[x]. Used for the hardware control of pad turn enabling.</p> <p>0<sub>D</sub> 1 ... 7<sub>D</sub> 8</p>

**LED and Touch-Sense (LEDTS)**

Field	Bits	Type	Description
<b>COLLEV</b>	28	rw	<b>Active Level of LED Column</b> 0 <sub>B</sub> Active low 1 <sub>B</sub> Active high
<b>NR_LEDCOL</b> <sup>1)</sup>	[31:29]	rw	<b>Number of LED Columns</b> Defines the number of LED columns. 000 <sub>B</sub> 1 LED column 001 <sub>B</sub> 2 LED columns 010 <sub>B</sub> 3 LED columns 011 <sub>B</sub> 4 LED columns 100 <sub>B</sub> 5 LED columns 101 <sub>B</sub> 6 LED columns 110 <sub>B</sub> 7 LED columns 111 <sub>B</sub> 8 LED columns (max. LED columns = 7 if bit TS_EN = 1)  <i>Note: LED column is enabled in sequence starting from highest column number. If touch-sense function is not enabled, COLA is activated in last time slice.</i>
<b>0</b>	[15:8]	r	<b>Reserved</b> Read as 0; should be written with 0.

1) This bit can only be modified when bit CLK\_PS = 0.

**EVFR**

The EVFR register contains the status flags for events and control bits for requesting clearance of event flags.

**EVFR**

**Event Flag Register (0C<sub>H</sub>) Reset Value: 0000 0000<sub>H</sub>**

31	30	29	28	27	26	25	24	23	22	21	20	19	18	17	16
0												CTP	CTF	CTS	
r												F	F	F	
												w	w	w	
15	14	13	12	11	10	9	8	7	6	5	4	3	2	1	0
0												TSC			
r												TRO	TPF	TFF	TSF
												VF	rh	rh	rh
												rh	rh	rh	rh

**LED and Touch-Sense (LEDTS)**

Field	Bits	Type	Description
<b>TSF</b>	0	rh	<b>Time Slice Interrupt Flag</b> Set on activation of each new time slice, including when bit CLK_PS is set from 0. To be cleared by software.
<b>TFF</b>	1	rh	<b>(Extended) Time Frame Interrupt Flag</b> Set on activation of each new (extended) time frame, including when bit CLK_PS is set from 0.
<b>TPF</b>	2	rh	<b>Autoscan Time Period Interrupt Flag</b> Set on activation of each new time period, including when bit CLK_PS is set from 0. This bit will never be set in case of hardware pad turn control is disabled (bit PADTSW = 1).
<b>TSCTROVF</b>	3	rh	<b>TS-Counter Overflow Indication</b> This bit indicates whether a TS-counter overflow has occurred. This bit is cleared on new pad turn, triggered on compare match. 0 <sub>B</sub> No overflow has occurred. 1 <sub>B</sub> The TS-counter has overflowed at least once.
<b>CTSF</b>	16	w	<b>Clear Time Slice Interrupt Flag</b> 0 <sub>B</sub> No action. 1 <sub>B</sub> Bit TSF is cleared. Read always as 0.
<b>CTFF</b>	17	w	<b>Clear (Extended) Time Frame Interrupt Flag</b> 0 <sub>B</sub> No action. 1 <sub>B</sub> Bit TFF is cleared. Read always as 0.
<b>CTPF</b>	18	w	<b>Clear Autoscan Time Period Interrupt Flag</b> 0 <sub>B</sub> No action. 1 <sub>B</sub> Bit TPF is cleared. Read always as 0.
<b>0</b>	[31:19], [15:4]	r	<b>Reserved</b> Read as 0; should be written with 0.

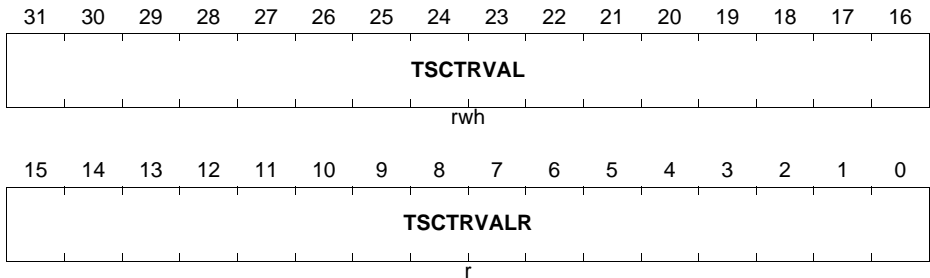
**TSVAL**

The TSVAL register holds the current and shadow touch sense counter values.

**LED and Touch-Sense (LEDTS)**

**TSVAL**

**Touch-sense TS-Counter Value (10<sub>H</sub>)** **Reset Value: 0000 0000<sub>H</sub>**



Field	Bits	Type	Description
<b>TSCTRVALR</b>	[15:0]	r	<b>Shadow TS-Counter Value (Read)</b> This is the latched value of the TS-counter (on every extended time frame event). It shows the latest valid oscillation count from the last completed time slice.
<b>TSCTRVAL</b>	[31:16]	rwh	<b>TS-Counter Value</b> This is the actual TS-counter value. It can only be written when no pad turn is active. The counter may be enabled for automatic reset once per (extended) frame on the start of a new pad turn on the next TSIN[x] pin.

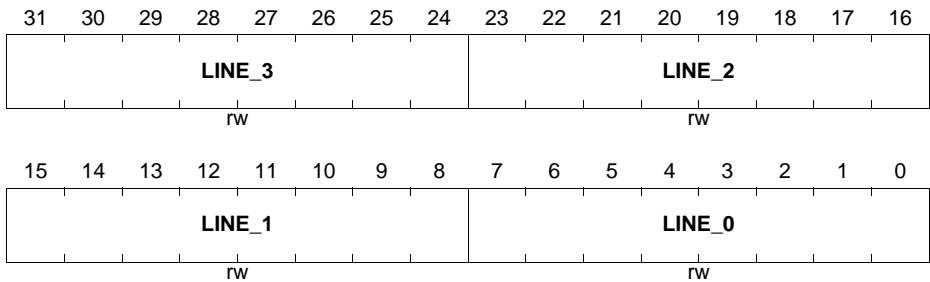
**LINE<sub>x</sub> (x = 0-1)**

The LINE<sub>x</sub> registers hold the values that are output to the respective line pins during their active column period.

**LED and Touch-Sense (LEDTS)**

**LINE0**

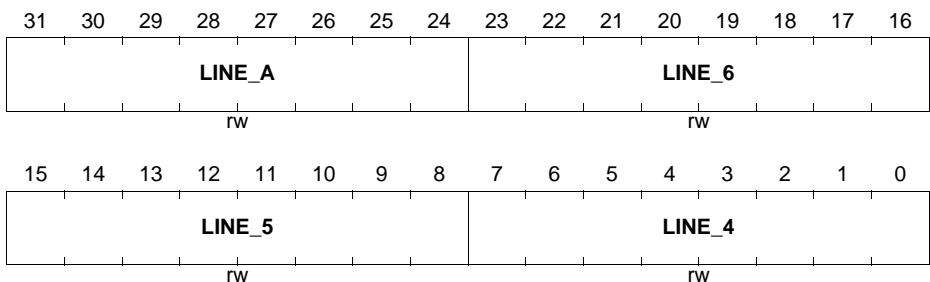
**Line Pattern Register 0** (14<sub>H</sub>) **Reset Value: 0000 0000<sub>H</sub>**



Field	Bits	Type	Description
<b>LINE_0,</b> <b>LINE_1,</b> <b>LINE_2,</b> <b>LINE_3</b>	[7:0], [15:8], [23:16], [31:24]	rw	<b>Output on LINE[x]</b> This value is output on LINE[x] to pin when LED COL[x] is active.

**LINE1**

**Line Pattern Register 1** (18<sub>H</sub>) **Reset Value: 0000 0000<sub>H</sub>**



Field	Bits	Type	Description
<b>LINE_4,</b> <b>LINE_5,</b> <b>LINE_6</b>	[7:0], [15:8], [23:16]	rw	<b>Output on LINE[x]</b> This value is output on LINE[x] to pin when LED COL[x] is active.

**LED and Touch-Sense (LEDTS)**

Field	Bits	Type	Description
<b>LINE_A</b>	[31:24]	rw	<b>Output on LINE[x]</b> This value is output on LINE[x] to pin when LED COLA or touch-sense time slice is active.

**LDCMP<sub>x</sub> (x = 0-1)**

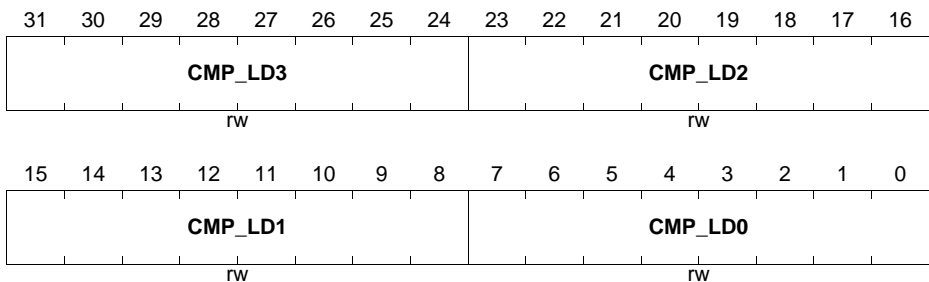
The LDCMP<sub>x</sub> registers hold the COMPARE values for their respective LED columns. These values are used for LED brightness control.

**LDCMP0**

**LED Compare Register 0**

**(1C<sub>H</sub>)**

**Reset Value: 0000 0000<sub>H</sub>**



Field	Bits	Type	Description
<b>CMP_LD0,</b> <b>CMP_LD1,</b> <b>CMP_LD2,</b> <b>CMP_LD3</b>	[7:0], [15:8], [23:16], [31:24]	rw	<b>Compare Value for LED COL[x]</b>

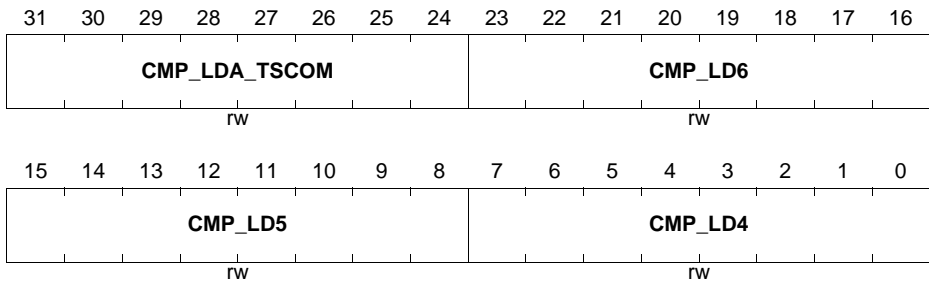
**LED and Touch-Sense (LEDTS)**

**LDCMP1**

**LED Compare Register 1**

(20<sub>H</sub>)

Reset Value: 0000 0000<sub>H</sub>



Field	Bits	Type	Description
<b>CMP_LD4, CMP_LD5, CMP_LD6</b>	[7:0], [15:8], [23:16]	rw	<b>Compare Value for LED COL[x]</b>
<b>CMP_LDA_TS COM</b>	[31:24]	rw	<b>Compare Value for LED COLA / Common Compare Value for Touch-sense Pad Turns LED function</b> The compare value for LED COLA is only valid when touch-sense function is not enabled. Touch-sense function The common compare value for touch-sense pad turns is enabled by set TSCCMP bit. When enabled for common compare, settings in SFRs LEDTS_TSCMP0,1 are not referenced.

**TSCMPx (x = 0-1)**

The TSCMPx registers hold the COMPARE values for their respective touch pad input lines. These values determine the size of the pad oscillation window for each pad input lines during their pad turn.



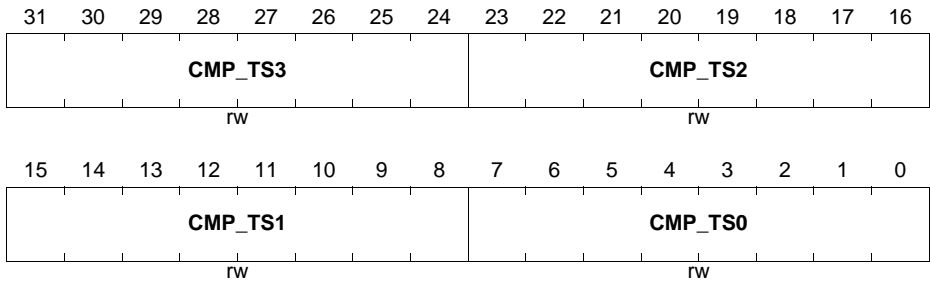
**LED and Touch-Sense (LEDTS)**

**TSCMP0**

**Touch-sense Compare Register 0**

**(24<sub>H</sub>)**

**Reset Value: 0000 0000<sub>H</sub>**



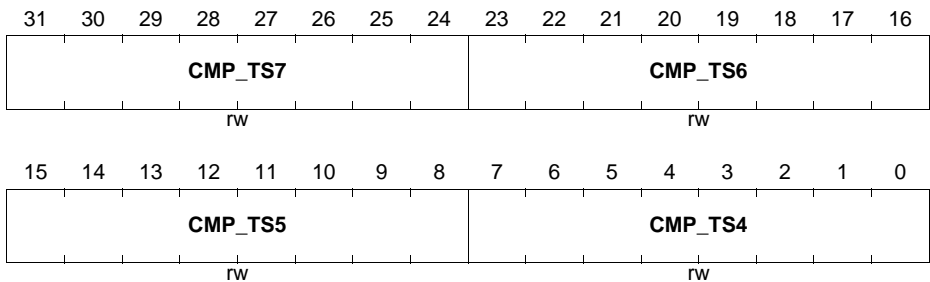
Field	Bits	Type	Description
<b>CMP_TS0,</b> <b>CMP_TS1,</b> <b>CMP_TS2,</b> <b>CMP_TS3</b>	[7:0], [15:8], [23:16], [31:24]	rw	<b>Compare Value for Touch-Sense TSIN[x]</b>

**TSCMP1**

**Touch-sense Compare Register 1**

**(28<sub>H</sub>)**

**Reset Value: 0000 0000<sub>H</sub>**



Field	Bits	Type	Description
<b>CMP_TS4,</b> <b>CMP_TS5,</b> <b>CMP_TS6,</b> <b>CMP_TS7</b>	[7:0], [15:8], [23:16], [31:24]	rw	<b>Compare Value for Touch-Sense TSIN[x]</b>

**LED and Touch-Sense (LEDTS)**

**14.12 Interconnects**

The LEDTS has interconnection to other peripherals enabling higher level of automation without requiring software. [Table 14-10](#) provides a list of the pin connections.

LEDTSx.FN is an output signal denoting LEDTS active function. This signal can be used as a source for VADC request gating and background gating. LEDTSx.SR0 is an output signal denoting LEDTS kernel service request. This signal can be used either as an interrupt trigger or for general purpose to CCU4.

**Table 14-10 Pin Connections**

Input/Output	I/O	Connected To	Description
LEDTS0.TSIN0	I	P0.7	LEDTS Touch-sense 0 input
LEDTS0.TSIN1	I	P0.6	LEDTS Touch-sense 1 input
LEDTS0.TSIN2	I	P0.5	LEDTS Touch-sense 2 input
LEDTS0.TSIN3	I	P0.4	LEDTS Touch-sense 3 input
LEDTS0.TSIN4	I	P0.3	LEDTS Touch-sense 4 input
LEDTS0.TSIN5	I	P0.2	LEDTS Touch-sense 5 input
LEDTS0.TSIN6	I	P0.1	LEDTS Touch-sense 6 input
LEDTS0.TSIN7	I	P0.0	LEDTS Touch-sense 7 input
LEDTS0.LINE0	O	P0.7	LEDTS Line 0 output
LEDTS0.LINE1	O	P0.6	LEDTS Line 1 output
LEDTS0.LINE2	O	P0.5	LEDTS Line 2 output
LEDTS0.LINE3	O	P0.4	LEDTS Line 3 output
LEDTS0.LINE4	O	P0.3	LEDTS Line 4 output
LEDTS0.LINE5	O	P0.2	LEDTS Line 5 output
LEDTS0.LINE6	O	P0.1	LEDTS Line 6 output
LEDTS0.LINE7	O	P0.0	LEDTS Line 7 output
LEDTS0.COLA	O	P0.8 P1.5	LEDTS Column A output
LEDTS0.COL0	O	P0.7 P0.15 P1.0	LEDTS Column 0 output
LEDTS0.COL1	O	P0.6 P0.14 P1.1	LEDTS Column 1 output

**LED and Touch-Sense (LEDTS)**

**Table 14-10 Pin Connections** (cont'd)

<b>Input/Output</b>	<b>I/O</b>	<b>Connected To</b>	<b>Description</b>
LEDTS0.COL2	O	P0.5 P0.13 P1.2	LEDTS Column 2 output
LEDTS0.COL3	O	P0.4 P0.12 P1.3	LEDTS Column 3 output
LEDTS0.COL4	O	P0.11 P1.4	LEDTS Column 4 output
LEDTS0.COL5	O	P0.10	LEDTS Column 5 output
LEDTS0.COL6	O	P0.9	LEDTS Column 6 output
LEDTS0.EXTENDED0	O	P0.7.HW0	
LEDTS0.EXTENDED1	O	P0.6.HW0	
LEDTS0.EXTENDED2	O	P0.5.HW0	
LEDTS0.EXTENDED3	O	P0.4.HW0	
LEDTS0.EXTENDED4	O	P0.3.HW0	
LEDTS0.EXTENDED5	O	P0.2.HW0	
LEDTS0.EXTENDED6	O	P0.1.HW0	
LEDTS0.EXTENDED7	O	P0.0.HW0	
LEDTS0.FN	O	VADC0.BGREQGTI	VADC background gating input I
		VADC0.G0REQGTI	VADC request gating input I
		VADC0.G1REQGTI	VADC request gating input I
LEDTS0.SR0	O	NVIC	Interrupt trigger
		CCU40.IN2L	General purpose function
LEDTS1.TSIN0	I	P0.8	LEDTS Touch-sense 0 input
LEDTS1.TSIN1	I	P0.9	LEDTS Touch-sense 1 input
LEDTS1.TSIN2	I	P0.10	LEDTS Touch-sense 2 input
LEDTS1.TSIN3	I	P0.11	LEDTS Touch-sense 3 input
LEDTS1.TSIN4	I	P0.12	LEDTS Touch-sense 4 input
LEDTS1.TSIN5	I	P0.13	LEDTS Touch-sense 5 input
LEDTS1.TSIN6	I	P0.14	LEDTS Touch-sense 6 input
LEDTS1.TSIN7	I	P0.15	LEDTS Touch-sense 7 input
LEDTS1.LINE0	O	P0.8	LEDTS Line 0 output

**LED and Touch-Sense (LEDTS)**

**Table 14-10 Pin Connections** (cont'd)

<b>Input/Output</b>	<b>I/O</b>	<b>Connected To</b>	<b>Description</b>
LEDTS1.LINE1	O	P0.9	LEDTS Line 1 output
LEDTS1.LINE2	O	P0.10	LEDTS Line 2 output
LEDTS1.LINE3	O	P0.11	LEDTS Line 3 output
LEDTS1.LINE4	O	P0.12	LEDTS Line 4 output
LEDTS1.LINE5	O	P0.13	LEDTS Line 5 output
LEDTS1.LINE6	O	P0.14	LEDTS Line 6 output
LEDTS1.LINE7	O	P0.15	LEDTS Line 7 output
LEDTS1.COLA	O	P1.0	LEDTS Column A output
LEDTS1.COL0	O	P0.15 P1.1	LEDTS Column 0 output
LEDTS1.COL1	O	P0.14 P1.2	LEDTS Column 1 output
LEDTS1.COL2	O	P0.13 P1.3	LEDTS Column 2 output
LEDTS1.COL3	O	P0.12 P1.4 P2.11	LEDTS Column 3 output
LEDTS1.COL4	O	P2.10	LEDTS Column 4 output
LEDTS1.COL5	O	P2.0	LEDTS Column 5 output
LEDTS1.COL6	O	P2.1	LEDTS Column 6 output
LEDTS1.EXTENDED0	O	P0.8.HW0	
LEDTS1.EXTENDED1	O	P0.9.HW0	
LEDTS1.EXTENDED2	O	P0.10.HW0	
LEDTS1.EXTENDED3	O	P0.11.HW0	
LEDTS1.EXTENDED4	O	P0.12.HW0	
LEDTS1.EXTENDED5	O	P0.13.HW0	
LEDTS1.EXTENDED6	O	P0.14.HW0	
LEDTS1.EXTENDED7	O	P0.15.HW0	
LEDTS1.FN	O	VADC0.BGREQGTJ	VADC background gating input J
		VADC0.G0REQGTJ	VADC request gating input J
		VADC0.G1REQGTJ	VADC request gating input J

**LED and Touch-Sense (LEDTS)**

**Table 14-10 Pin Connections** (cont'd)

<b>Input/Output</b>	<b>I/O</b>	<b>Connected To</b>	<b>Description</b>
LEDTS1.SR0	O	NVIC	Interrupt trigger
		CCU40.IN3L	General purpose function

## 15 Universal Serial Interface Channel (USIC)

The **Universal Serial Interface Channel** module (USIC) is a flexible interface module covering several serial communication protocols. A USIC module contains two independent communication channels named USIC<sub>x</sub>\_CH0 and USIC<sub>x</sub>\_CH1, with *x* being the number of the USIC module (e.g. channel 0 of USIC module 0 is referenced as USIC0\_CH0). The user can program during run-time which protocol will be handled by each communication channel and which pins are used.

### References

The following documents are referenced for further information

- [7] IIC Bus Specification (Philips Semiconductors v2.1)
- [8] IIS Bus Specification (Philips Semiconductors June 5 1996 revision)

### 15.1 Overview

This section gives an overview about the feature set of the USIC.

#### 15.1.1 Features

Each USIC channel can be individually configured to match the application needs, e.g. the protocol can be selected or changed during run time without the need for a reset. The following protocols are supported:

- **UART** (ASC, asynchronous serial channel)
  - Module capability: receiver/transmitter with max. baud rate  $f_{PB} / 4$
  - Wide baud rate range down to single-digit baud rates
  - Number of data bits per data frame: 1 to 63
  - MSB or LSB first
- **LIN** Support by hardware (Local Interconnect Network)
  - Data transfers based on ASC protocol
  - Baud rate detection possible by built-in capture event of baud rate generator
  - Checksum generation under software control for higher flexibility
- **SSC/SPI** (synchronous serial channel with or without slave select lines)
  - Standard, Dual and Quad SPI format supported
  - Module capability: maximum baud rate  $f_{PB} / 2$ , limited by loop delay
  - Number of data bits per data frame 1 to 63, more with explicit stop condition
  - Parity bit generation supported
  - MSB or LSB first
- **IIC** (Inter-IC Bus)
  - Application baud rate 100 kbit/s to 400 kbit/s
  - 7-bit and 10-bit addressing supported
  - Full master and slave device capability

**Universal Serial Interface Channel (USIC)**

- **IIS** (infotainment audio bus)
  - Module capability: maximum baud rate  $f_{PB} / 2$

*Note: The real baud rates that can be achieved in a real application depend on the operating frequency of the device, timing parameters as described in the Data Sheet, signal delays on the PCB and timings of the peer device.*

In addition to the flexible choice of the communication protocol, the USIC structure has been designed to reduce the system load (CPU load) allowing efficient data handling. The following aspects have been considered:

- **Data buffer capability**

The standard buffer capability includes a double word buffer for receive data and a single word buffer for transmit data. This allows longer CPU reaction times (e.g. interrupt latency).

- **Additional FIFO buffer capability**

In addition to the standard buffer capability, the received data and the data to be transmitted can be buffered in a FIFO buffer structure. The size of the receive and the transmit FIFO buffer can be programmed independently. Depending on the application needs, a total buffer capability of 64 data words can be assigned to the receive and transmit FIFO buffers of a USIC module (the two channels of the USIC module share the 64 data word buffer).

In addition to the FIFO buffer, a bypass mechanism allows the introduction of high-priority data without flushing the FIFO buffer.

- **Transmit control information**

For each data word to be transmitted, a 5-bit transmit control information has been added to automatically control some transmission parameters, such as word length, frame length, or the slave select control for the SPI protocol. The transmit control information is generated automatically by analyzing the address where the user software has written the data word to be transmitted (32 input locations =  $2^5 = 5$  bit transmit control information).

This feature allows individual handling of each data word, e.g. the transmit control information associated to the data words stored in a transmit FIFO can automatically modify the slave select outputs to select different communication targets (slave devices) without CPU load. Alternatively, it can be used to control the frame length.

- **Flexible frame length control**

The number of bits to be transferred within a data frame is independent of the data word length and can be handled in two different ways. The first option allows automatic generation of frames up to 63 bits with a known length. The second option supports longer frames (even unlimited length) or frames with a dynamically controlled length.

- **Interrupt capability**

The events of each USIC channel can be individually routed to one of 6 service request outputs SR[5:0] available for each USIC module, depending on the

---

## **Universal Serial Interface Channel (USIC)**

application needs. Furthermore, specific start and end of frame indications are supported in addition to protocol-specific events.

- **Flexible interface routing**  
Each USIC channel offers the choice between several possible input and output pins connections for the communications signals. This allows a flexible assignment of USIC signals to pins that can be changed without resetting the device.
- **Input conditioning**  
Each input signal is handled by a programmable input conditioning stage with programmable filtering and synchronization capability.
- **Baud rate generation**  
Each USIC channel contains its own baud rate generator. The baud rate generation can be based either on the internal module clock or on an external frequency input. This structure allows data transfers with a frequency that can not be generated internally, e.g. to synchronize several communication partners.
- **Transfer trigger capability**  
In master mode, data transfers can be triggered by events generated outside the USIC module, e.g. by an input pin or a timer unit (transmit data validation). This feature allows time base related data transmission.
- **Debugger support**  
The USIC offers specific addresses to read out received data without interaction with the FIFO buffer mechanism. This feature allows debugger accesses without the risk of a corrupted receive data sequence.

To reach a desired baud rate, two criteria have to be respected, the module capability and the application environment. The module capability is defined with respect to the module's input clock frequency, being the base for the module operation. Although the module's capability being much higher (depending on the module clock and the number of module clock cycles needed to represent a data bit), the reachable baud rate is generally limited by the application environment. In most cases, the application environment limits the maximum reachable baud rate due to driver delays, signal propagation times, or due to EMI reasons.

*Note: Depending on the selected additional functions (such as digital filters, input synchronization stages, sample point adjustment, data structure, etc.), the maximum reachable baud rate can be limited. Please also take care about additional delays, such as (internal or external) propagation delays and driver delays (e.g. for collision detection in ASC mode, for IIC, etc.).*



Universal Serial Interface Channel (USIC)

A block diagram of the USIC module/channel structure is shown in **Figure 15-1**.

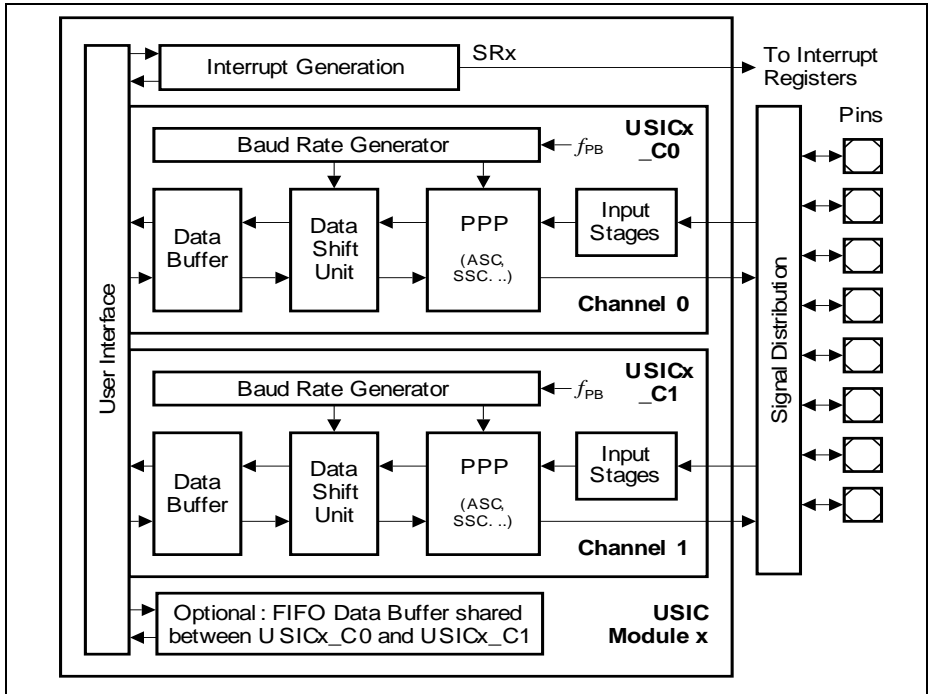


Figure 15-1 USIC Module/Channel Structure

## **15.2 Operating the USIC**

This section describes how to operate the USIC communication channel.

### **15.2.1 USIC Structure Overview**

This section introduces the USIC structure.

#### **15.2.1.1 Channel Structure**

The USIC module contains two independent communication channels, with a structure as shown in [Figure 15-1](#).

The data shift unit and the data buffering of each channel support full-duplex data transfers. The protocol-specific actions are handled by the protocol pre-processors (PPP). In order to simplify data handling, an additional FIFO data buffer is optionally available for each USIC module to store transmit and receive data for each channel.

Due to the independent channel control and baud rate generation, the communication protocol, baud rate and the data format can be independently programmed for each communication channel.

#### **15.2.1.2 Input Stages**

For each protocol, the number of input signals used depends on the selected protocol. Each input signal is handled by an input stage (called DX<sub>n</sub>, where n=0-5) for signal conditioning, such as input selection, polarity control, or a digital input filter. They can be classified according to their meaning for the protocols, see [Table 15-1](#).

The inputs marked as "optional" are not needed for the standard function of a protocol and may be used for enhancements. The descriptions of protocol-specific items are given in the related protocol chapters. For the external frequency input, please refer to the baud rate generator section, and for the transmit data validation, to the data handling section.

**Universal Serial Interface Channel (USIC)**

**Table 15-1 Input Signals for Different Protocols**

<b>Selected Protocol</b>	<b>Shift Data Input(s) (handled by DX0, DX3, DX4 and DX5)<sup>1)</sup></b>	<b>Shift Clock Input (handled by DX1)</b>	<b>Shift Control Input (handled by DX2)</b>
<b>ASC, LIN</b>	RXD	optional: external frequency input or TXD collision detection	optional: transmit data validation
<b>Standard SSC, SPI (Master)</b>	DIN0 (MRST, MISO)	optional: external frequency input or delay compensation	optional: transmit data validation or delay compensation
<b>Standard SSC, SPI (Slave)</b>	DIN0 (MTRSR, MOSI)	SCLKIN	SELIN
<b>Dual- SSC, SPI (Master)</b>	DIN[1:0] (MRST[1:0], MISO[1:0])	optional: external frequency input or delay compensation	optional: transmit data validation or delay compensation
<b>Dual- SSC, SPI (Slave)</b>	DIN[1:0] (MTRSR[1:0], MOSI[1:0])	SCLKIN	SELIN
<b>Quad- SSC, SPI (Master)</b>	DIN[3:0] (MRST[3:0], MISO[3:0])	optional: external frequency input or delay compensation	optional: transmit data validation or delay compensation
<b>Quad- SSC, SPI (Slave)</b>	DIN[3:0] (MTRSR[3:0], MOSI[3:0])	SCLKIN	SELIN
<b>IIC</b>	SDA	SCL	optional: transmit data validation
<b>IIS (Master)</b>	DIN0	optional: external frequency input or delay compensation	optional: transmit data validation or delay compensation
<b>IIS (Slave)</b>	DIN0	SCLKIN	WAIN

1) ASC, IIC, IIS and standard SSC protocols use only DX0 as the shift data input.

**Universal Serial Interface Channel (USIC)**

*Note: To allow a certain flexibility in assigning required USIC input functions to port pins of the device, each input stage can select the desired input location among several possibilities.*

*The available USIC signals and their port locations are listed in the interconnects section, see [Page 15-226](#).*

**15.2.1.3 Output Signals**

For each protocol, up to 14 protocol-related output signals are available. The number of actually used outputs depends on the selected protocol. They can be classified according to their meaning for the protocols, see [Table 15-2](#).

The outputs marked as “optional” are not needed for the standard function of a protocol and may be used for enhancements. The descriptions of protocol-specific items are given in the related protocol chapters. The MCLKOUT output signal has a stable frequency relation to the shift clock output (the frequency of MCLKOUT can be higher than for SCLKOUT) for synchronization purposes of a slave device to a master device. If the baud rate generator is not needed for a specific protocol (e.g. in SSC slave mode), the SCLKOUT and MCLKOUT signals can be used as clock outputs with 50% duty cycle with a frequency that can be independent from the communication baud rate.

**Table 15-2 Output Signals for Different Protocols**

<b>Selected Protocol</b>	<b>Shift Data Output(s) DOUT[3:0]</b>	<b>Shift Clock Output SCLKOUT</b>	<b>Shift Control Outputs SELO[7:0]</b>	<b>Master Clock Output MCLKOUT</b>
<b>ASC, LIN</b>	TXD	not used	not used	optional: master time base
<b>Standard SSC, SPI (Master)</b>	DOUT0 (MSTR, MOSI)	master shift clock	slave select, chip select	optional: master time base
<b>Standard SSC, SPI (Slave)</b>	DOUT0 (MRST, MISO)	optional: independent clock output	not used	optional: independent clock output
<b>Dual-SSC, SPI (Master)</b>	DOUT[1:0] (MSTR[1:0], MOSI[1:0])	master shift clock	slave select, chip select	optional: master time base
<b>Dual-SSC, SPI (Slave)</b>	DOUT[1:0] (MRST[1:0], MISO[1:0])	optional: independent clock output	not used	optional: independent clock output

**Universal Serial Interface Channel (USIC)**

**Table 15-2 Output Signals for Different Protocols (cont'd)**

<b>Selected Protocol</b>	<b>Shift Data Output(s)</b> <b>DOUT[3:0]</b>	<b>Shift Clock Output</b> <b>SCLKOUT</b>	<b>Shift Control Outputs</b> <b>SELO[7:0]</b>	<b>Master Clock Output</b> <b>MCLKOUT</b>
<b>Quad-SSC, SPI (Master)</b>	DOUT[3:0] (MSTR[3:0], MOSI[3:0])	master shift clock	slave select, chip select	optional: master time base
<b>Quad-SSC, SPI (Slave)</b>	DOUT[3:0] (MRST[3:0], MISO[3:0])	optional: independent clock output	not used	optional: independent clock output
<b>IIC</b>	SDA	SCL	not used	optional: master time base
<b>IIS (master)</b>	DOUT0	master shift clock	WA	optional: master time base
<b>IIS (slave)</b>	DOUT0	optional: independent clock output	not used	optional: independent clock output

*Note: To allow a certain flexibility in assigning required USIC output functions to port pins of the device, most output signals are made available on several port pins. The port control itself defines pin-by-pin which signal is used as output signal for a port pin (see port chapter). The available USIC signals and their port locations are listed in the interconnects section, see [Page 15-226](#).*

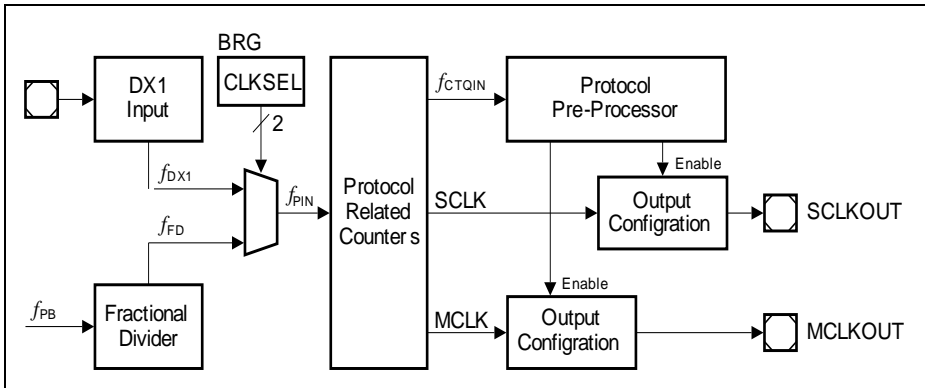
### 15.2.1.4 Baud Rate Generator

Each USIC Channel contains a baud rate generator structured as shown in [Figure 15-2](#). It is based on coupled divider stages, providing the frequencies needed for the different protocols. It contains:

- A fractional divider to generate the input frequency  $f_{PIN} = f_{FD}$  for baud rate generation based on the internal system frequency  $f_{PB}$ .
- The DX1 input to generate the input frequency  $f_{PIN} = f_{DX1}$  for baud rate generation based on an external signal.
- Two protocol-related counters: the divider mode counter to provide the master clock signal MCLK, the shift clock signal SCLK, and other protocol-related signals; and the capture mode timer for time interval measurement, e.g. baud rate detection.
- A time quanta counter associated to the protocol pre-processor defining protocol-specific timings, such shift control signals or bit timings, based on the input frequency  $f_{CTQIN}$ .

**Universal Serial Interface Channel (USIC)**

- The output signals MCLKOUT and SCLKOUT of the protocol-related divider that can be made available on pins. In order to adapt to different applications, some output characteristics of these signals can be configured.  
For device-specific details about availability of USIC signals on pins please refer to the interconnects section.



**Figure 15-2 Baud Rate Generator**

### 15.2.1.5 Channel Events and Interrupts

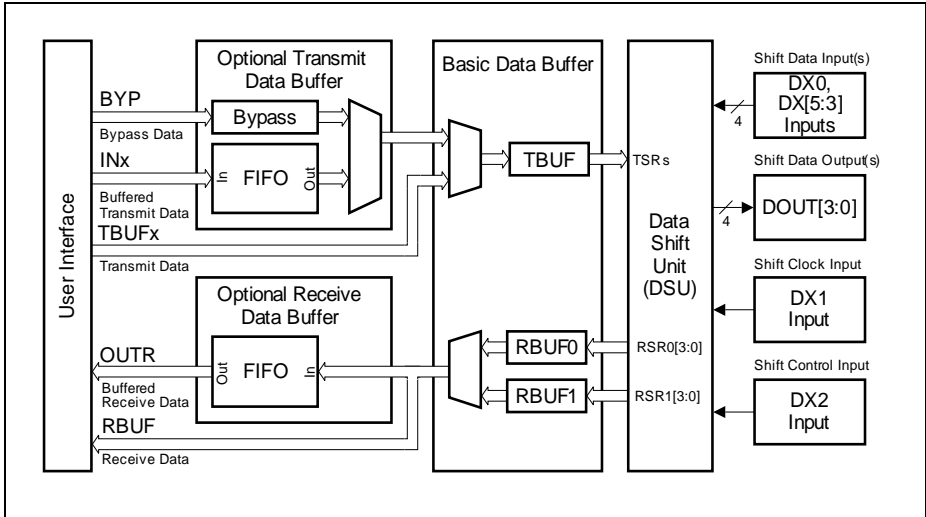
The notification of the user about events occurring during data traffic and data handling is based on:

- Data transfer events related to the transmission or reception of a data word, independent of the selected protocol.
- Protocol-specific events depending on the selected protocol.
- Data buffer events related to data handling by the optional FIFO data buffers.

### 15.2.1.6 Data Shifting and Handling

The data handling of the USIC module is based on an independent data shift unit (DSU) and a buffer structure that is similar for the supported protocols. The data shift and buffer registers are 16-bit wide (maximum data word length), but several data words can be concatenated to achieve longer data frames. The DSU inputs are the shift data (handled by input stage DX0, DX3, DX4 and DX5), the shift clock (handled by the input stage DX1), and the shift control (handled by the input stage DX2). The signal DOUT[3:0] represents the shift data outputs.

**Universal Serial Interface Channel (USIC)**



**Figure 15-3 Principle of Data Buffering**

The principle of data handling comprises:

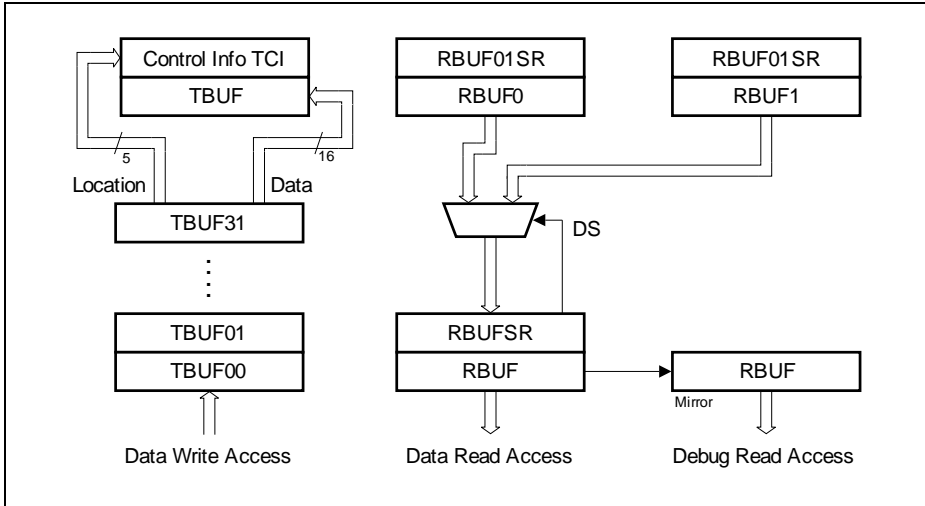
- A transmitter with transmit shift registers (TSR and TSR[3:0]) in the DSU and a transmit data buffer (TBUF). A data validation scheme allows triggering and gating of data transfers by external events under certain conditions.
- A receiver with two alternating sets of receive shift registers (RSR0[3:0] and RSR1[3:0]) in the DSU and a double receive buffer structure (RBUF0, RBUF1). The alternating receive shift registers support the reception of data streams and data frames longer than one data word.
- A user interface to handle data, interrupts, and status and control information.

**Basic Data Buffer Structure**

The read access to received data and the write access of data to be transmitted can be handled by a basic data buffer structure.

The received data stored in the receiver buffers RBUF0/RBUF1 can be read directly from these registers. In this case, the user has to take care about the reception sequence to read these registers in the correct order. To simplify the use of the receive buffer structure, register RBUF has been introduced. A read action from this register delivers the data word received first (oldest data) to respect the reception sequence. With a read access from at least the low byte of RBUF, the data is automatically declared to be no longer new and the next received data word becomes visible in RBUF and can be read out next.

**Universal Serial Interface Channel (USIC)**



**Figure 15-4 Data Access Structure without additional Data Buffer**

It is recommended to read the received data words by accesses to RBUF and to avoid handling of RBUF0 and RBUF1. The USIC module also supports the use of debug accesses to receive data words. Debugger read accesses should not disturb the receive data sequence and, as a consequence, should not target RBUF. Therefore, register RBUFD has been introduced. It contains the same value as RBUF, but a read access from RBUFD does not change the status of the data (same data can be read several times). In addition to the received data, some additional status information about each received data word is available in the receiver buffer status register RBUF01SR (related to data in RBUF0 and RBUF1) and RBUFSR (related to data in RBUF).

Transmit data can be loaded to TBUF by software by writing to the transmit buffer input locations TBUF $x$  ( $x = 00-31$ ), consisting of 32 consecutive addresses. The data written to one of these input locations is stored in the transmit buffer TBUF. Additionally, the address of the written location is evaluated and can be used for additional control purposes. This 5-bit wide information (named **Transmit Control Information TCI**) can be used for different purposes in different protocols.

**FIFO Buffer Structure**

To allow easier data setup and handling, an additional data buffering mechanism can be optionally supported. The data buffer is based on the first-in-first-out principle (FIFO) that ensures that the sequence of transferred data words is respected.

If a FIFO buffer structure is used, the data handling scheme (data with associated control information) is similar to the one without FIFO. The additional FIFO buffer can be



---

**Universal Serial Interface Channel (USIC)**

independently enabled/disabled for transmission and reception (e.g. if data FIFO buffers are available for a specific USIC channel, it is possible to configure the transmit data path without and the receive data path with FIFO buffering).

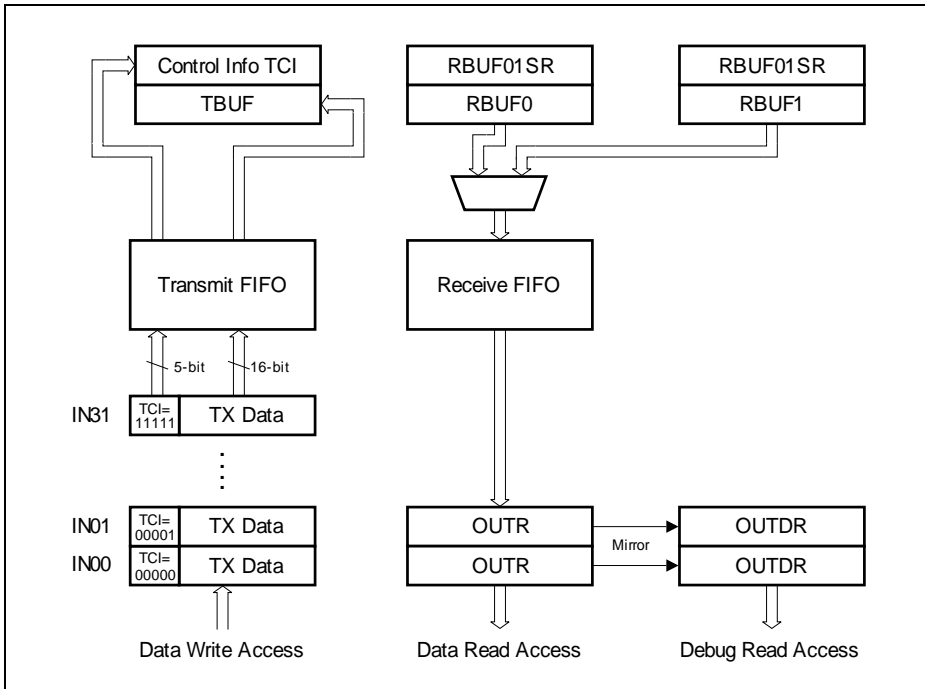
The transmit FIFO buffer is addressed by using 32 consecutive address locations for INx instead of TBUFx (x=00-31) regardless of the FIFO depth. The 32 addresses are used to store the 5-bit TCI (together with the written data) associated with each FIFO entry.

The receive FIFO can be read out at two independent addresses, OUTR and OUTDR instead of RBUF and RBUFD. A read from the OUTR location triggers the next data packet to be available for the next read (general FIFO mechanism). In order to allow non-intrusive debugging (without risk of data loss), a second address location (OUTDR) has been introduced. A read at this location delivers the same value as OUTR, but without modifying the FIFO contents.

The transmit FIFO also has the capability to bypass the data stream and to load bypass data to TBUF. This can be used to generate high-priority messages or to send an emergency message if the transmit FIFO runs empty. The transmission control of the FIFO buffer can also use the transfer trigger and transfer gating scheme of the transmission logic for data validation (e.g. to trigger data transfers by events).

*Note: The available size of a FIFO data buffer for a USIC channel depends on the specific device. Please refer to the implementation chapter for details about available FIFO buffer capability.*

**Universal Serial Interface Channel (USIC)**



**Figure 15-5 Data Access Structure with FIFO**

### 15.2.2 Operating the USIC Communication Channel

This section describes how to operate a USIC communication channel, including protocol control and status, mode control and interrupt handling. The following aspects have to be taken into account:

- Enable the USIC module for operation and configure the behavior for the different device operation modes (see [Page 15-15](#)).
- Configure the pinning (refer to description in the corresponding protocol section).
- Configure the data structure (shift direction, word length, frame length, polarity, etc.).
- Configure the data buffer structure of the optional FIFO buffer area. A FIFO buffer can only be enabled if the related bit in register CCFG is set.
- Select a protocol by CCR.MODE. A protocol can only be selected if the related bit in register CCFG is set.

### **15.2.2.1 Protocol Control and Status**

The protocol-related control and status information are located in the protocol control register PCR and in the protocol status register PSR. These registers are shared between the available protocols. As a consequence, the meaning of the bit positions in these registers is different within the protocols.

#### **Use of PCR Bits**

The signification of the bits in register PCR is indicated by the protocol-related alias names for the different protocols.

- PCR for the ASC protocol (see [Page 15-65](#))
- PCR for the SSC protocol (see [Page 15-97](#))
- PCR for the IIC protocol (see [Page 15-128](#))
- PCR for the IIS protocol (see [Page 15-147](#))

#### **Use of PSR Flags**

The signification of the flags in register PSR is indicated by the protocol-related alias names for the different protocols.

- PSR flags for the ASC protocol (see [Page 15-68](#))
- PSR flags for the SSC protocol (see [Page 15-101](#))
- PSR flags for the IIC protocol (see [Page 15-131](#))
- PSR flags for the IIS protocol (see [Page 15-149](#))

### 15.2.2.2 Mode Control

The mode control concept for system control tasks, such as suspend request for debugging, allows to program the module behavior under different device operating conditions. The behavior of a communication channel can be programmed for each of the device operating modes (normal operation, suspend mode). Therefore, each communication channel has an associated kernel state configuration register KSCFG defining its behavior in the following operating modes:

- **Normal operation:**  
This operating mode is the default operating mode when no suspend request is pending. The module clock is not switched off and the USIC registers can be read or written. The channel behavior is defined by KSCFG.NOMCFG.
- **Suspend mode:**  
This operating mode is requested when a suspend request is pending in the device. The module clock is not switched off and the USIC registers can be read or written. The channel behavior is defined by KSCFG.SUMCFG.

The four kernel modes defined by the register KSCFG are shown in [Table 15-3](#).

**Table 15-3 USIC Communication Channel Behavior**

Kernel Mode	Channel Behavior	KSCFG. NOMCFG
Run mode 0	Channel operation as specified, no impact on data transfer	00 <sub>B</sub>
Run mode 1		01 <sub>B</sub>
Stop mode 0	Explicit stop condition as described in the protocol chapters	10 <sub>B</sub>
Stop mode 1		11 <sub>B</sub>

Generally, bit field KSCFG.NOMCFG should be configured for run mode 0 as default setting for standard operation. If a communication channel should not react to a suspend request (and to continue its operation as in normal mode), bit field KSCFG.SUMCFG has to be configured with the same value as KSCFG.NOMCFG. If the communication channel should show a different behavior and stop operation when a specific stop condition is reached, the code for stop mode 0 or stop mode 1 have to be written to KSCFG.SUMCFG.

The stop conditions are defined for the selected protocol (see mode control description in the protocol section).

*Note: The stop mode selection strongly depends on the application needs and it is very unlikely that different stop modes are required in parallel in the same application. As a result, only one stop mode type (either 0 or 1) should be used in the bit fields in register KSCFG. Do not mix stop mode 0 and stop mode 1 and avoid transitions*

**Universal Serial Interface Channel (USIC)**

from stop mode 0 to stop mode 1 (or vice versa) for the same communication channel.

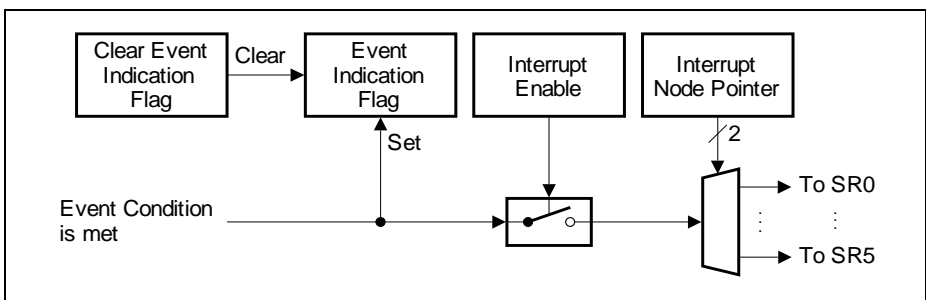
*Note: In XMC1200, bit field KSCFG.SUMCFG is reset to its default value by any reset. If the suspend function is required during debugging, it is recommended that it is enabled in the user initialization code. Before programming the bit field, the module clock has to be enabled and special care needs to be taken while enabling the module clock as described in the CCU (Clock Gating Control) section of the SCU chapter.*

**15.2.2.3 General Channel Events and Interrupts**

The general event and interrupt structure is shown in **Figure 15-6**. If a defined condition is met, an event is detected and an event indication flag becomes automatically set. The flag stays set until it is cleared by software. If enabled, an interrupt can be generated if an event is detected. The actual status of the event indication flag has no influence on the interrupt generation. As a consequence, the event indication flag does not need to be cleared to generate further interrupts.

Additionally, the service request output SRx of the USIC channel that becomes activated in case of an event condition can be selected by an interrupt node pointer. This structure allows to assign events to interrupts, e.g. depending on the application, several events can share the same interrupt routine (several events activate the same SRx output) or can be handled individually (only one event activates one SRx output).

The SRx outputs are connected to interrupt control registers to handle the CPU reaction to the service requests. This assignment is described in the implementation section on **Page 15-153**.



**Figure 15-6 General Event and Interrupt Structure**

### 15.2.2.4 Data Transfer Events and Interrupts

The data transfer events are based on the transmission or reception of a data word. The related indication flags are located in register PSR. All events can be individually enabled for interrupt generation.

- Receive event to indicate that a data word has been received:  
If a new received word becomes available in the receive buffer RBUF0 or RBUF1, either a receive event or an alternative receive event occurs.  
The receive event occurs if bit RBUFSR.PERR = 0. It is indicated by flag PSR.RIF and, if enabled, leads to receive interrupt.
- Receiver start event to indicate that a data word reception has started:  
When the receive clock edge that shifts in the first bit of a new data word is detected and reception is enabled, a receiver start event occurs. It is indicated by flag PSR.RSIF and, if enabled, leads to transmit buffer interrupt.  
In full duplex mode, this event follows half a shift clock cycle after the transmit buffer event and indicates when the shift control settings are internally “frozen” for the current data word reception and a new setting can be programmed.  
In SSC and IIS mode, the transmit data valid flag TCSR.TDV is cleared in single shot mode with the receiver start event.
- Alternative receive event to indicate that a specific data word has been received:  
If a new received word becomes available in the receive buffer RBUF0 or RBUF1, either a receive event or an alternative receive event occurs.  
The alternative receive event occurs if bit RBUFSR.PERR = 1. It is indicated by flag PSR.AIF and, if enabled, leads to alternative receive interrupt.  
Depending on the selected protocol, bit RBUFSR.PERR is set to indicate a parity error in ASC mode, the reception of the first byte of a new frame in IIC mode, and the WA information about right/left channel in IIS mode. In SSC mode, it is used as indication if the received word is the first data word, and is set if first and reset if not.
- Transmit shift event to indicate that a data word has been transmitted:  
A transmit shift event occurs with the last shift clock edge of a data word. It is indicated by flag PSR.TSIF and, if enabled, leads to transmit shift interrupt.
- Transmit buffer event to indicate that a data word transmission has been started:  
When a data word from the transmit buffer TBUF has been loaded to the shift register and a new data word can be written to TBUF, a transmit buffer event occurs. This happens with the transmit clock edge that shifts out the first bit of a new data word and transmission is enabled. It is indicated by flag PSR.TBIF and, if enabled, leads to transmit buffer interrupt.  
This event also indicates when the shift control settings (word length, shift direction, etc.) are internally “frozen” for the current data word transmission.  
In ASC and IIC mode, the transmit data valid flag TCSR.TDV is cleared in single shot mode with the transmit buffer event.
- Data lost event to indicate a loss of the oldest received data word:  
If the data word available in register RBUF (oldest data word from RBUF0 or RBUF1)

**Universal Serial Interface Channel (USIC)**

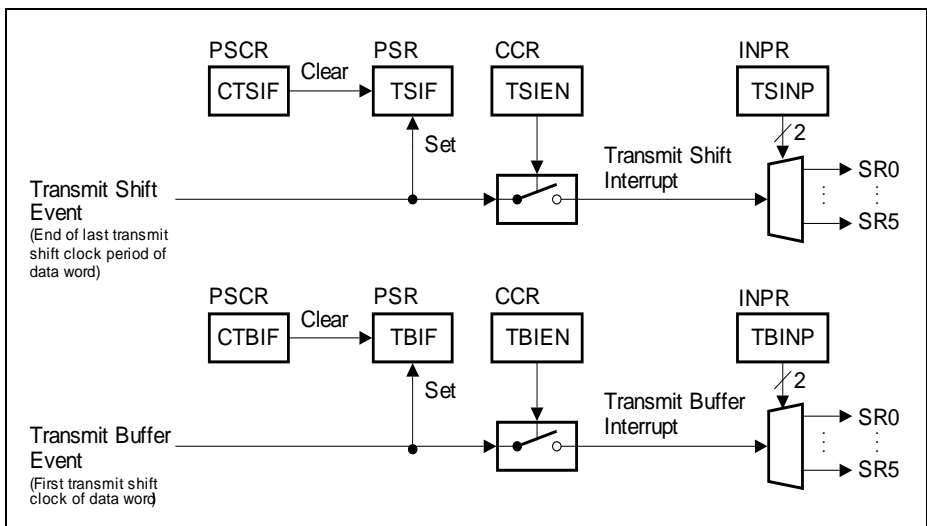
has not been read out before it becomes overwritten with new incoming data, this event occurs. It is indicated by flag PSR.DLIF and, if enabled, leads to a protocol interrupt.

**Table 15-4** shows the registers, bits and bit fields indicating the data transfer events and controlling the interrupts of a USIC channel.

**Table 15-4 Data Transfer Events and Interrupt Handling**

Event	Indication Flag	Indication cleared by	Interrupt enabled by	SRx Output selected by
Standard receive event	PSR.RIF	PSCR.CRIF	CCR.RIEN	INPR.RINP
Receive start event	PSR.RSIF	PSCR.CRSIF	CCR.RSIEN	INPR.TBINP
Alternative receive event	PSR.AIF	PSCR.CAIF	CCR.AIEN	INPR.AINP
Transmit shift event	PSR.TSIF	PSCR.CTSIF	CCR.TSIEN	INPR.TSINP
Transmit buffer event	PSR.TBIF	PSCR.CTBIF	CCR.TBIEN	INPR.TBINP
Data lost event	PSR.DLIF	PSCR.CDLIF	CCR.DLIEN	INPR.PINP

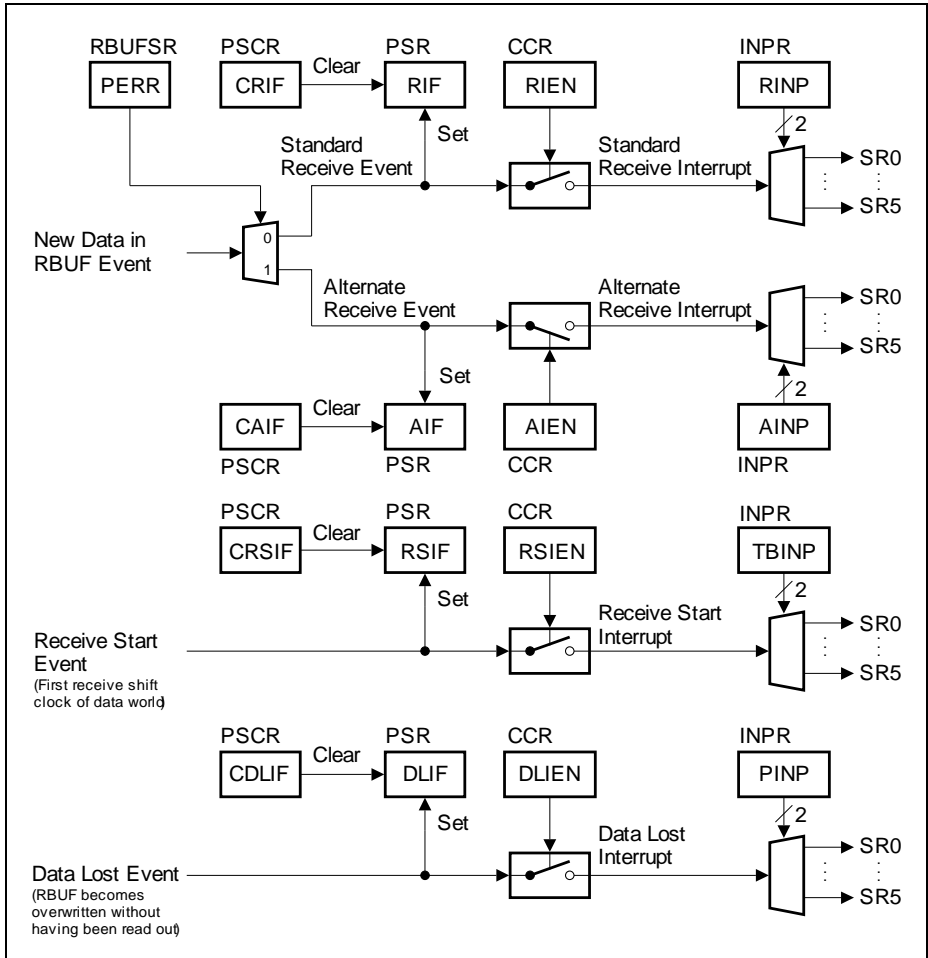
**Figure 15-7** shows the two transmit events and interrupts.



**Figure 15-7 Transmit Events and Interrupts**

**Universal Serial Interface Channel (USIC)**

Figure 15-8 shows the receive events and interrupts.



**Figure 15-8 Receive Events and Interrupts**

**15.2.2.5 Baud Rate Generator Event and Interrupt**

The baud rate generator event is based on the capture mode timer reaching its maximum value. It is indicated by flag PSR.BRGIF and, if enabled, leads to a protocol interrupt.



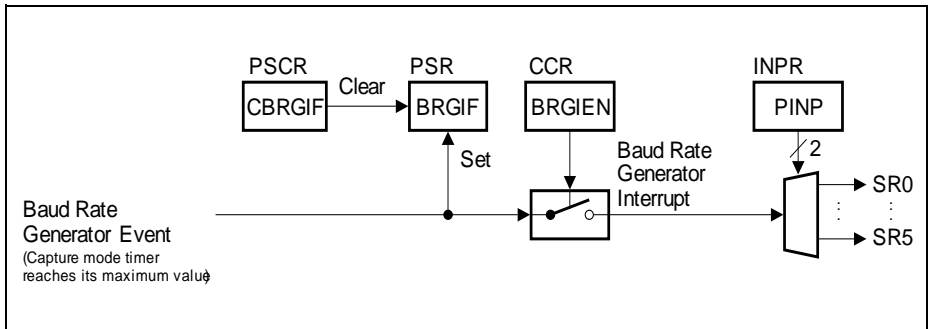
**Universal Serial Interface Channel (USIC)**

**Table 15-5** shows the registers, bits and bit fields indicating the baud rate generator event and controlling the interrupt of a USIC channel.

**Table 15-5 Baud Rate Generator Event and Interrupt Handling**

Event	Indication Flag	Indication cleared by	Interrupt enabled by	SRx Output selected by
Baud rate generator event	PSR. BRGIF	PSCR. CBRGIF	CCR. BRGIEN	INPR.PINP

**Figure 15-9** shows the baud rate generator event and interrupt.



**Figure 15-9 Baud Rate Generator Event and Interrupt**

### 15.2.2.6 Protocol-specific Events and Interrupts

These events are related to protocol-specific actions that are described in the corresponding protocol chapters. The related indication flags are located in register PSR. All events can be individually enabled for the generation of the common protocol interrupt.

- Protocol-specific events in ASC mode:  
Synchronization break, data collision on the transmit line, receiver noise, format error in stop bits, receiver frame finished, transmitter frame finished
- Protocol-specific events in SSC mode:  
MSLS event (start-end of frame in master mode), DX2T event (start/end of frame in slave mode), both based on slave select signals, parity error
- Protocol-specific events in IIC mode:  
Wrong transmit code (error in frame sequence), start condition received, repeated start condition received, stop condition received, non-acknowledge received, arbitration lost, slave read request, other general errors
- Protocol-specific events in IIS mode:  
DX2T event (change on WA line), WA falling edge or rising edge detected, WA generation finished

**Table 15-6 Protocol-specific Events and Interrupt Handling**

<b>Event</b>	<b>Indication Flag</b>	<b>Indication cleared by</b>	<b>Interrupt enabled by</b>	<b>SRx Output selected by</b>
Protocol-specific events in ASC mode	PSR.ST[8:2]	PSCR.CST[8:2]	PCR.CTR[7:3]	INPR.PINP
Protocol-specific events in SSC mode	PSR.ST[3:2]	PSCR.CST[3:2]	PCR.CTR[15:14]	INPR.PINP
Protocol-specific events in IIC mode	PSR.ST[8:1]	PSCR.CST[8:1]	PCR.CTR[24:18]	INPR.PINP
Protocol-specific events in IIS mode	PSR.ST[6:3]	PSCR.CST[6:3]	PCR.CTR[6:4], PCR.CTR[15]	INPR.PINP

### 15.2.3 Operating the Input Stages

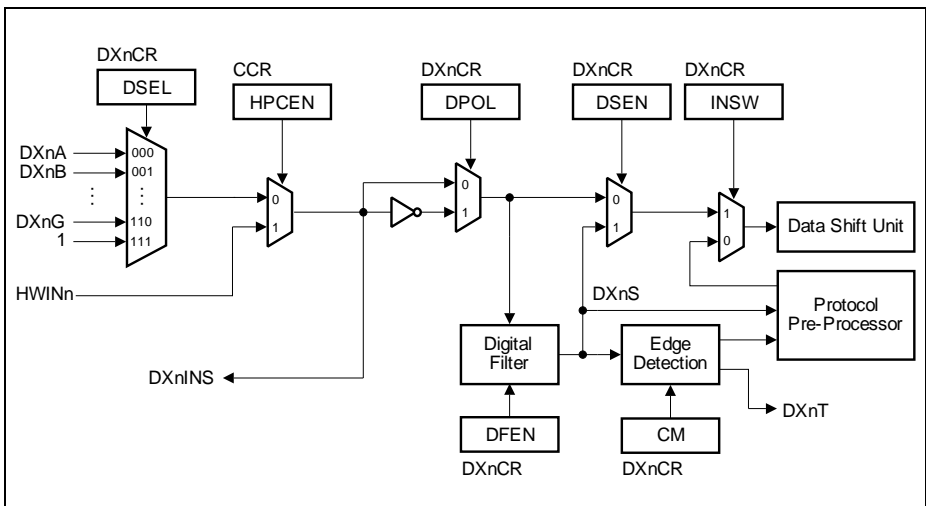
All input stages offer the same feature set. They are used for all protocols, because the signal conditioning can be adapted in a very flexible way and the digital filters can be switched on and off separately.

### 15.2.3.1 General Input Structure

There are generally two types of input stages, one for the data input stages DX0, DX[5:3] and the other for non-data input stages DX[2:1], as shown in [Figure 15-10](#) and [Figure 15-11](#). The difference is that for the data input stages, the input signal can be additionally selected from the port signal HWINn if hardware port control is enabled through CCR.HPCEN bit. All other enable/disable functions and selections are controlled independently for each input stage by bits in the registers DXnCR.

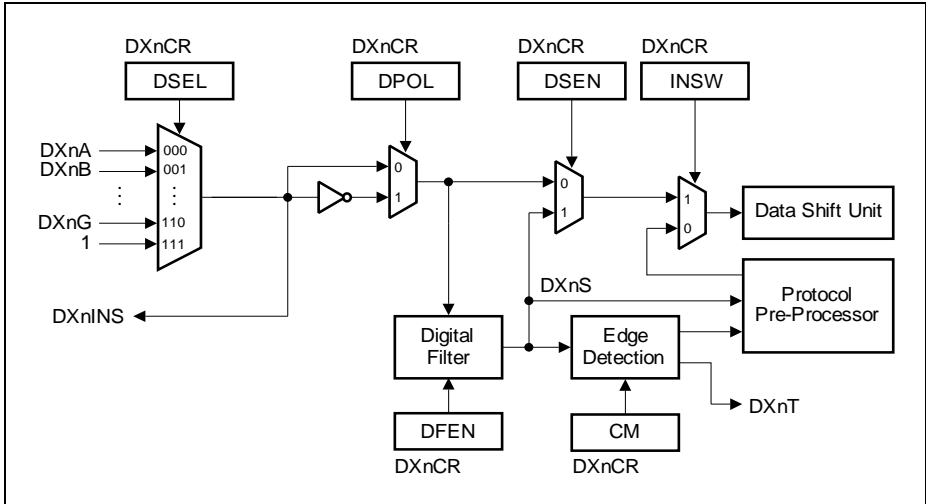
The desired input signal can be selected among the input lines DXnA to DXnG and a permanent 1-level by programming bit field DSEL (for the data input stages, hardware port control must be disabled for DSEL to take effect). Please refer to the interconnects section ([Section 15.12](#)) for the device-specific input signal assignment. Bit DPOL allows a polarity inversion of the selected input signal to adapt the input signal polarity to the internal polarity of the data shift unit and the protocol state machine. For some protocols, the input signals can be directly forwarded to the data shift unit for the data transfers (DSEN = 0, INSW = 1) without any further signal conditioning. In this case, the data path does not contain any delay due to synchronization or filtering.

In the case of noise on the input signals, there is the possibility to synchronize the input signal (signal DXnS is synchronized to  $f_{PB}$ ) and additionally to enable a digital noise filter in the signal path. The synchronized input signal (and optionally filtered if DFEN = 1) is taken into account by DSEN = 1. Please note that the synchronization leads to a delay in the signal path of 2-3 times the period of  $f_{PB}$ .



**Figure 15-10 Input Conditioning for DX0 and DX[5:3]**

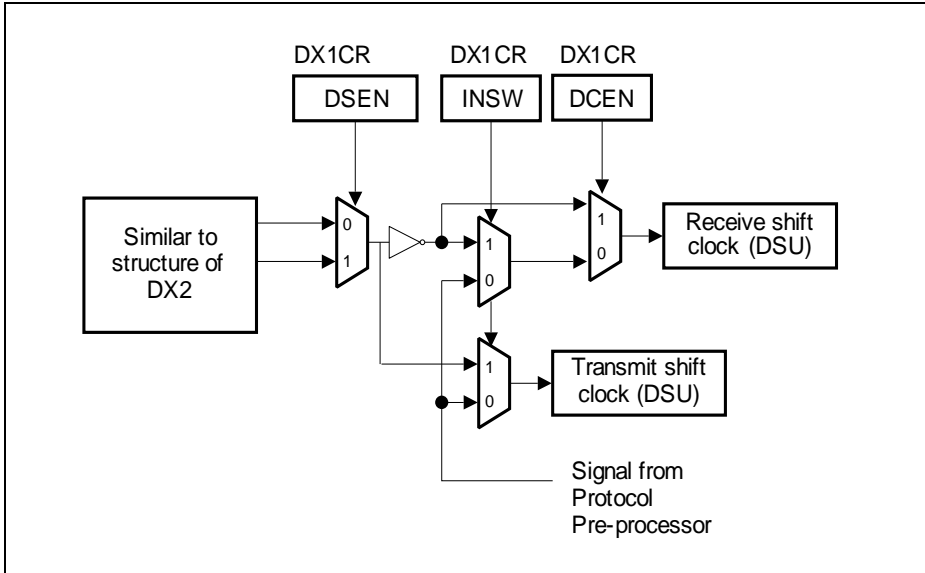
**Universal Serial Interface Channel (USIC)**



**Figure 15-11 Input Conditioning for DX[2:1]**

If the input signals are handled by a protocol pre-processor, the data shift unit is directly connected to the protocol pre-processor by  $INSW = 0$ . The protocol pre-processor is connected to the synchronized input signal  $DXnS$  and, depending on the selected protocol, also evaluates the edges.

To support delay compensation in SSC and IIS protocols, the  $DX1$  input stage additionally allows the receive shift clock to be controlled independently from the transmit shift clock through the bit  $DCEN$ . When  $DCEN = 0$ , the shift clock source is selected by  $INSW$  and is the same for both receive and transmit. When  $DCEN = 1$ , the receive shift clock is derived from the selected input line as shown in [Figure 15-12](#).



**Figure 15-12 Delay Compensation Enable in DX1**

### 15.2.3.2 Digital Filter

The digital filter can be enabled to reduce noise on the input signals. Before being filtered, the input signal becomes synchronized to  $f_{PB}$ . If the filter is disabled, signal DXnS corresponds to the synchronized input signal. If the filter is enabled, pulses shorter than one filter sampling period are suppressed in signal DXnS. After an edge of the synchronized input signal, signal DXnS changes to the new value if two consecutive samples of the new value have been detected.

In order to adapt the filter sampling period to different applications, it can be programmed. The first possibility is the system frequency  $f_{PB}$ . Longer pulses can be suppressed if the fractional divider output frequency  $f_{FD}$  is selected. This frequency is programmable in a wide range and can also be used to determine the baud rate of the data transfers.

In addition to the synchronization delay of 2-3 periods of  $f_{PB}$ , an enabled filter adds a delay of up to two filter sampling periods between the selected input and signal DXnS.

### 15.2.3.3 Edge Detection

The synchronized (and optionally filtered) signal DXnS can be used as input to the data shift unit and is also an input to the selected protocol pre-processor. If the protocol pre-processor does not use the DXnS signal for protocol-specific handling, DXnS can be

## Universal Serial Interface Channel (USIC)

used for other tasks, e.g. to control data transmissions in master mode (a data word can be tagged valid for transmission, see chapter about data buffering).

A programmable edge detection indicates that the desired event has occurred by activating the trigger signal DXnT (introducing a delay of one period of  $f_{PB}$  before a reaction to this event can take place).

### 15.2.3.4 Selected Input Monitoring

The selected input signal of each input stage has been made available with the signals DXnINS. These signals can be used in the system to trigger other actions, e.g. to generate interrupts.

### 15.2.3.5 Loop Back Mode

The USIC transmitter output signals can be connected to the corresponding receiver inputs of the same communication channel in loop back mode. Therefore, the input "G" of the input stages that are needed for the selected protocol have to be selected. In this case, drivers for ASC, SSC, and IIS can be evaluated on-chip without the connections to port pins. Data transferred by the transmitter can be received by the receiver as if it would have been sent by another communication partner.

## 15.2.4 Operating the Baud Rate Generator

The following blocks can be configured to operate the baud rate generator, see also [Figure 15-2](#).

### 15.2.4.1 Fractional Divider

The fractional divider generates its output frequency  $f_{FD}$  by either dividing the input frequency  $f_{PB}$  by an integer factor  $n$  or by multiplication of  $n/1024$ . It has two operating modes:

- Normal divider mode (FDR.DM = 01<sub>B</sub>):  
In this mode, the output frequency  $f_{FD}$  is derived from the input clock  $f_{PB}$  by an integer division by a value between 1 and 1024. The division is based on a counter FDR.RESULT that is incremented by 1 with  $f_{PB}$ . After reaching the value 3FF<sub>H</sub>, the counter is loaded with FDR.STEP and then continues counting. In order to achieve  $f_{FD} = f_{PB}$ , the value of STEP has to be programmed with 3FF<sub>H</sub>.  
The output frequency in normal divider mode is defined by the equation:

$$f_{FD} = f_{PB} \times \frac{1}{n} \quad \text{with } n = 1024 - \text{STEP} \quad (15.1)$$

- Fractional divider mode (FDR.DM = 10<sub>B</sub>):  
In this mode, the output frequency  $f_{FD}$  is derived from the input clock  $f_{PB}$  by a

## Universal Serial Interface Channel (USIC)

fractional multiplication of  $n/1024$  for a value of  $n$  between 0 and 1023. In general, the fractional divider mode allows to program the average output clock frequency with a finer granularity than in normal divider mode. Please note that in fractional divider mode  $f_{FD}$  can have a maximum period jitter of one  $f_{PB}$  period. This jitter is not accumulated over several cycles.

The frequency  $f_{FD}$  is generated by an addition of FDR.STEP to FDR.RESULT with  $f_{PB}$ . The frequency  $f_{FD}$  is based on the overflow of the addition result over  $3FF_H$ .

The output frequency in fractional divider mode is defined by the equation:

$$f_{FD} = f_{PB} \times \frac{n}{1024} \quad \text{with } n = \text{STEP} \quad (15.2)$$

The output frequency  $f_{FD}$  of the fractional divider is selected for baud rate generation by  $\text{BRG.CLKSEL} = 00_B$ .

### 15.2.4.2 External Frequency Input

The baud rate can be generated referring to an external frequency input (instead of to  $f_{PB}$ ) if in the selected protocol the input stage DX1 is not needed ( $\text{DX1CTR.INSW} = 0$ ). In this case, an external frequency input signal at the DX1 input stage can be synchronized and sampled with the system frequency  $f_{PB}$ . It can be optionally filtered by the digital filter in the input stage. This feature allows data transfers with frequencies that can not be generated by the device itself, e.g. for specific audio frequencies.

If  $\text{BRG.CLKSEL} = 10_B$ , the trigger signal DX1T determines  $f_{DX1}$ . In this mode, either the rising edge, the falling edge, or both edges of the input signal can be used for baud rate generation, depending on the configuration of the DX1T trigger event by bit field  $\text{DX1CTR.CM}$ . The signal MCLK toggles with each trigger event of DX1T.

If  $\text{BRG.CLKSEL} = 11_B$ , the rising edges of the input signal can be used for baud rate generation. The signal MCLK represents the synchronized input signal DX1S.

Both, the high time and the low time of external input signal must each have a length of minimum 2 periods of  $f_{PB}$  to be used for baud rate generation.

### 15.2.4.3 Divider Mode Counter

The divider mode counter is used for an integer division delivering the output frequency  $f_{PDI}$ . Additionally, two divider stages with a fixed division by 2 provide the output signals MCLK and SCLK with 50% duty cycle. If the fractional divider mode is used, the maximum fractional jitter of 1 period of  $f_{PB}$  can also appear in these signals. The output frequencies of this divider is controlled by register BRG.

**Universal Serial Interface Channel (USIC)**

In order to define a frequency ratio between the master clock MCLK and the shift clock SCLK, the divider stage for MCLK is located in front of the divider by PDIV+1, whereas the divider stage for SCLK is located at the output of this divider.

$$f_{MCLK} = \frac{f_{PIN}}{2} \quad (15.3)$$

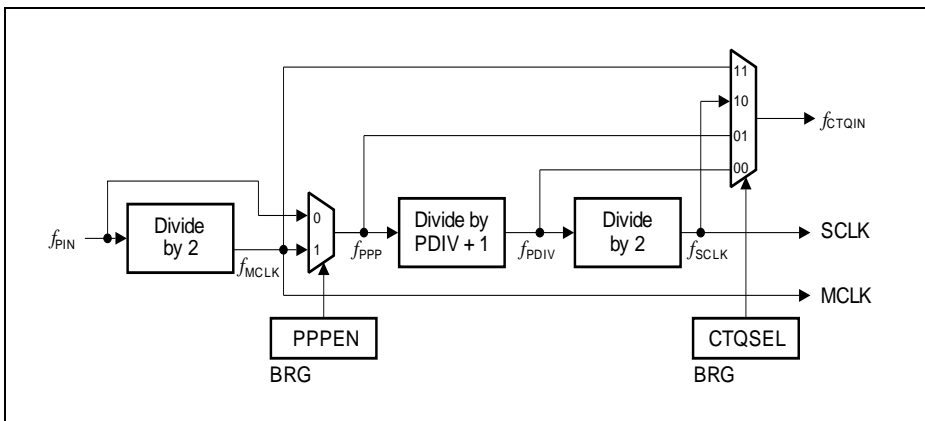
$$f_{SCLK} = \frac{f_{PDIV}}{2} \quad (15.4)$$

In the case that the master clock is used as reference for external devices (e.g. for IIS components) and a fixed phase relation to SCLK and other timing signals is required, it is recommended to use the MCLK signal as input for the PDIV divider. If the MCLK signal is not used or a fixed phase relation is not necessary, the faster frequency  $f_{PIN}$  can be selected as input frequency.

$$f_{PDIV} = f_{PIN} \times \frac{1}{PDIV + 1} \quad \text{if } PPEN = 0$$

$$f_{PDIV} = f_{MCLK} \times \frac{1}{PDIV + 1} \quad \text{if } PPEN = 1$$

(15.5)



**Figure 15-13 Divider Mode Counter**

**15.2.4.4 Capture Mode Timer**

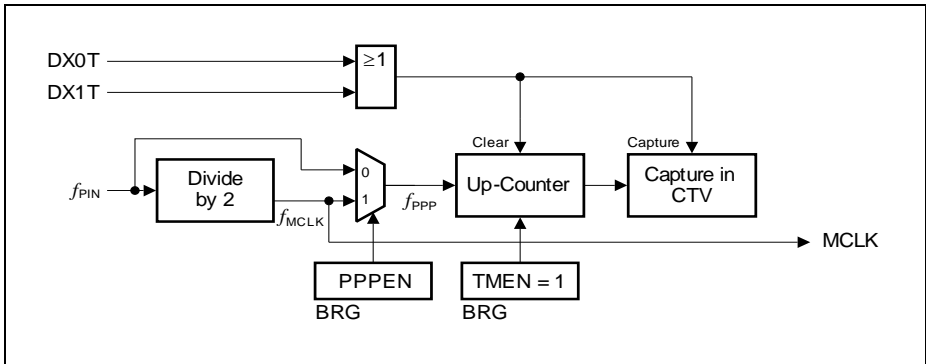
The capture mode timer is used for time interval measurement and is enabled by BRG.TMEN = 1. The timer works independently from the divider mode counter. Therefore, any serial data reception or transmission can continue while the timer is performing timing measurements. The timer counts  $f_{PPP}$  periods and stops counting



**Universal Serial Interface Channel (USIC)**

when it reaches its maximum value. Additionally, a baud rate generator interrupt event is generated (bit PSR.BRGIF becomes set).

If an event is indicated by DX0T or DX1T, the actual timer value is captured into bit field CMTR.CTV and the timer restarts from 0. Additionally, a transmit shift interrupt event is generated (bit PSR.TSIF becomes set).

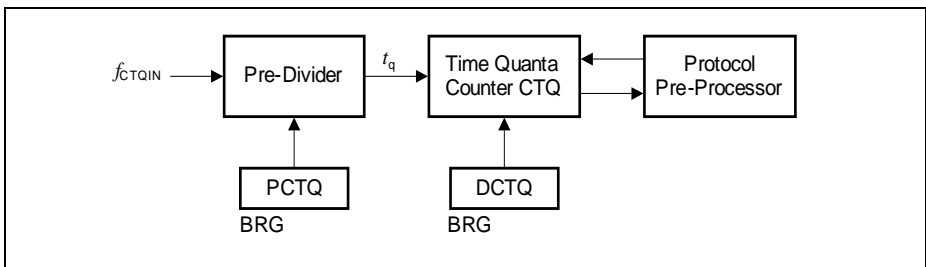


**Figure 15-14 Protocol-Related Counter (Capture Mode)**

The capture mode timer can be used to measure the baud rate in slave mode before starting or during data transfers, e.g. to measure the time between two edges of a data signal (by DX0T) or of a shift clock signal (by DX1T). The conditions to activate the DXnT trigger signals can be configured in each input stage.

**15.2.4.5 Time Quanta Counter**

The time quanta counter CTQ associated to the protocol pre-processor allows to generate time intervals for protocol-specific purposes. The length of a time quantum  $t_q$  is given by the selected input frequency  $f_{CTQIN}$  and the programmed pre-divider value. The meaning of the time quanta depend on the selected protocol, please refer to the corresponding chapters for more protocol-specific information.



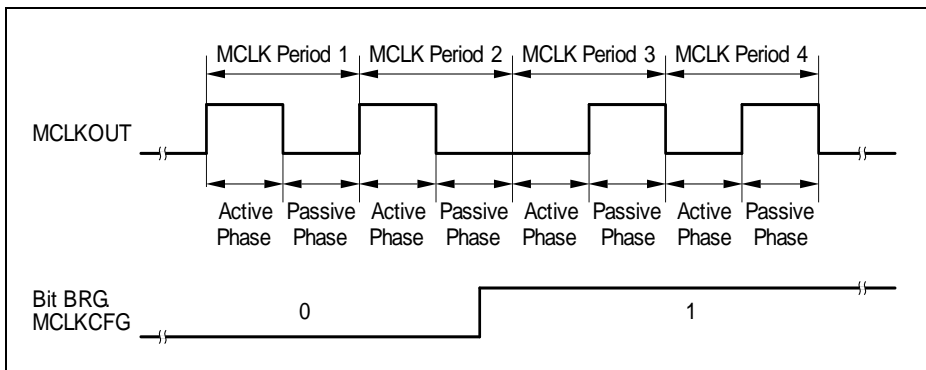
**Figure 15-15 Time Quanta Counter**

### 15.2.4.6 Master and Shift Clock Output Configuration

The master clock output signal MCLKOUT available at the corresponding output pin can be configured in polarity. The MCLK signal can be generated for each protocol in order to provide a kind of higher frequency time base compared to the shift clock.

The configuration mechanism of the master clock output signal MCLKOUT ensures that no shortened pulses can occur. Each MCLK period consists of two phases, an active phase, followed by a passive phase. The polarity of the MCLKOUT signal during the active phase is defined by the inverted level of bit BRG.MCLKCFG, evaluated at the start of the active phase. The polarity of the MCLKOUT signal during the passive phase is defined by bit BRG.MCLKCFG, evaluated at the start of the passive phase. If bit BRG.MCLKOUT is programmed with another value, the change is taken into account with the next change between the phases. This mechanism ensures that no shorter pulses than the length of a phase occur at the MCLKOUT output. In the example shown in [Figure 15-16](#), the value of BRG.MCLKCFG is changed from 0 to 1 during the passive phase of MCLK period 2.

The generation of the MCLKOUT signal is enabled/disabled by the protocol pre-processor, based on bit PCR.MCLK. After this bit has become set, signal MCLKOUT is generated with the next active phase of the MCLK period. If PCR.MCLK = 0 (MCLKOUT generation disabled), the level for the passive phase is also applied for active phase.



**Figure 15-16 Master Clock Output Configuration**

The shift clock output signal SCLKOUT available at the corresponding output pin can be configured in polarity and additionally, a delay of one period of  $f_{PDIV}$  (= half SCLK period) can be introduced. The delay allows to adapt the order of the shift clock edges to the application requirements. If the delay is used, it has to be taken into account for the calculation of the signal propagation times and loop delays.

The mechanism for the polarity control of the SCLKOUT signal is similar to the one for MCLKOUT, but based on bit field BRG.SCLKCFG. The generation of the SCLKOUT

---

**Universal Serial Interface Channel (USIC)**

signal is enabled/disabled by the protocol pre-processor. Depending on the selected protocol, the protocol pre-processor can control the generation of the SCLKOUT signal independently of the divider chain, e.g. for protocols without the need of a shift clock available at a pin, the SCLKOUT generation is disabled.

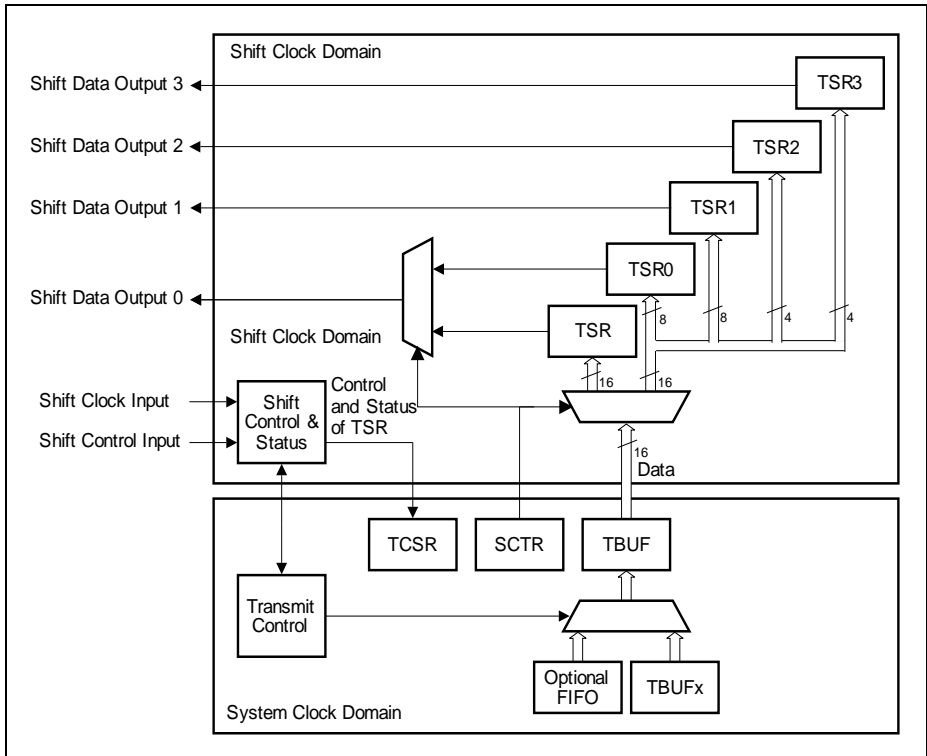
### **15.2.5 Operating the Transmit Data Path**

The transmit data path is based on 16-bit wide transmit shift registers (TSR and TSR[3:0]) and a transmit buffer TBUF. The data transfer parameters like data word length, data frame length, or the shift direction are controlled commonly for transmission and reception by the shift control register SCTR. The transmit control and status register TCSR controls the transmit data handling and monitors the transmit status.

A change of the value of the data shift output signal DOUTx only happens at the corresponding edge of the shift clock input signal. The level of the last data bit of a data word/frame is held constant at DOUTx until the next data word begins with the next corresponding edge of the shift clock.

#### **15.2.5.1 Transmit Buffering**

The transmit shift registers can not be directly accessed by software, because they are automatically updated with the value stored in the transmit buffer TBUF if a currently transmitted data word is finished and new data is valid for transmission. Data words can be loaded directly into TBUF by writing to one of the transmit buffer input locations TBUFx (see [Page 15-32](#)) or, optionally, by a FIFO buffer stage (see [Page 15-38](#)).



**Figure 15-17 Transmit Data Path**

### 15.2.5.2 Transmit Data Shift Mode

The transmit shift data can be selected to be shifted out one, two or four bits at a time through the corresponding number of output lines. This option allows the USIC to support protocols such as the Dual- and Quad-SSC. The selection is done through the bit field DSM in the shift control register SCTR.

*Note: The bit field SCTR.DSM controls the data shift mode for both the transmit and receive paths to allow the transmission and reception of data through one to four data lines.*

For the shift mode with two or four parallel data outputs, the data word and frame length must be in multiples of two or four respectively. The number of data shifts required to output a specific data word or data frame length is thus reduced by the factor of the number of parallel data output lines. For example, to transmit a 16-bit data word through four output lines, only four shifts are required.

**Universal Serial Interface Channel (USIC)**

Depending on the shift mode, different transmit shift registers with different bit composition are used as shown in **Table 15-7**. Note that the 'n' in the table denotes the shift number less one, i.e. for the first data shift  $n = 0$ , the second data shift  $n = 1$  and continues until the total number of shifts less one is reached.

For all transmit shift registers, whether the first bit shifted out is the MSB or LSB depends on the setting of SCTR.SDIR.

**Table 15-7 Transmit Shift Register Composition**

<b>Transmit Shift Registers</b>	<b>Single Data Output (SCTR.DSM = 00<sub>B</sub>)</b>	<b>Two Data Outputs (SCTR.DSM = 10<sub>B</sub>)</b>	<b>Four Data Outputs (SCTR.DSM = 11<sub>B</sub>)</b>
TSR	All data bits	Not used	Not used
TSR0	Not used	Bit $n*2$	Bit $n*4$
TSR1	Not used	Bit $n*2 + 1$	Bit $n*4 + 1$
TSR2	Not used	Not used	Bit $n*4 + 2$
TSR3	Not used	Not used	Bit $n*4 + 3$

**15.2.5.3 Transmit Control Information**

The transmit control information TCI is a 5-bit value derived from the address  $x$  of the written TBUF $x$  or IN $x$  input location. For example, writing to TBUF31 generates a TCI of 11111<sub>B</sub>.

The TCI can be used as an additional control parameter for data transfers to dynamically change the data word length, the data frame length, or other protocol-specific functions (for more details about this topic, please refer to the corresponding protocol chapters). The way how the TCI is used in different applications can be programmed by the bits WLEMD, FLEMD, SELMD, WAMD and HPCMD in register TCSR. Please note that not all possible settings lead to useful system behavior.

- **Word length control:**  
If TCSR.WLEMD = 1, bit field SCTR.WLE is updated with TCI[3:0] if a transmit buffer input location TBUF $x$  is written. This function can be used in all protocols to dynamically change the data word length between 1 and 16 data bits per data word. Additionally, bit TCSR.EOF is updated with TCI[4]. This function can be used in SSC master mode to control the slave select generation to finish data frames. It is recommended to program TCSR.FLEMD = TCSR.SELMD = TCSR.WAMD = TCSR.HPCMD = 0.
- **Frame length control:**  
If TCSR.FLEMD = 1, bit field SCTR.FLE[4:0] is updated with TCI[4:0] and SCTR.FLE[5] becomes 0 if a transmit buffer input location TBUF $x$  is written. This function can be used in all protocols to dynamically change the data frame length

## Universal Serial Interface Channel (USIC)

between 1 and 32 data bits per data frame. It is recommended to program  $TCSR.SELMD = TCSR.WLEMD = TCSR.WAMD = TCSR.HPCMD = 0$ .

- **Select output control:**  
If  $TCSR.SELMD = 1$ , bit field  $PCR.CTR[20:16]$  is updated with  $TCI[4:0]$  and  $PCR.CTR[23:21]$  becomes 0 if a transmit buffer input location  $TBUFx$  is written. This function can be used in SSC master mode to define the targeted slave device(s). It is recommended to program  $TCSR.WLEMD = TCSR.FLEMD = TCSR.WAMD = TCSR.HPCMD = 0$ .
- **Word address control:**  
If  $TCSR.WAMD = 1$ , bit  $TCSR.WA$  is updated with  $TCI[4]$  if a transmit buffer input location  $TBUFx$  is written. This function can be used in IIS mode to define if the data word is transmitted on the right or the left channel. It is recommended to program  $TCSR.WLEMD = TCSR.FLEMD = TCSR.SELMD = TCSR.HPCMD = 0$ .
- **Hardware Port control:**  
If  $TCSR.HPCMD = 1$ , bit field  $SCTR.DSM$  is updated with  $TCI[1:0]$  if a transmit buffer input location  $TBUFx$  is written. This function can be used in SSC protocols to dynamically change the number of data input and output lines to set up for standard, dual and quad SSC formats.  
Additionally, bit  $TCSR.HPCDIR$  is updated with  $TCI[2]$ . This function can be used in SSC protocols to control the pin(s) direction when the hardware port control function is enabled through  $CCR.HPCEN = 1$ . It is recommended to program  $TCSR.FLEMD = TCSR.WLEMD = TCSR.SELMD = TCSR.WAMD = 0$ .

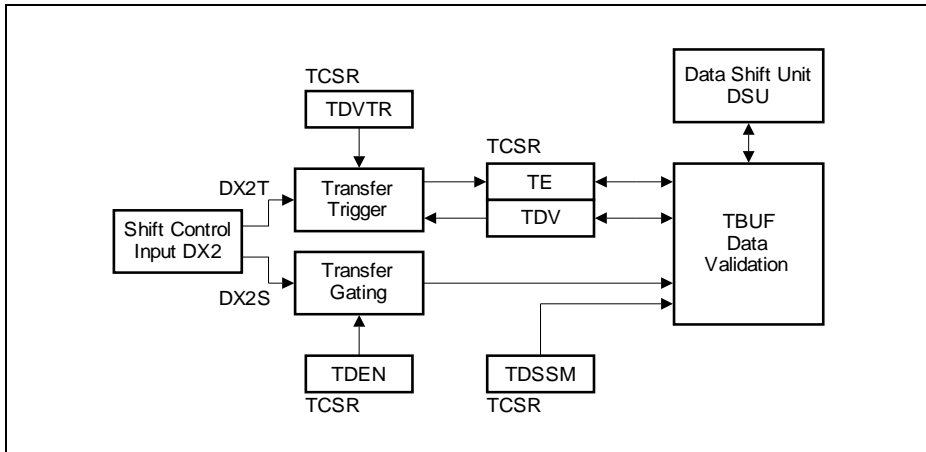
### 15.2.5.4 Transmit Data Validation

The data word in the transmit buffer  $TBUF$  can be tagged valid or invalid for transmission by bit  $TCSR.TDV$  (transmit data valid). A combination of data flow related and event related criteria define whether the data word is considered valid for transmission. A data validation logic checks the start conditions for each data word. Depending on the result of the check, the transmit shift register is loaded with different values, according to the following rules:

- If a USIC channel is the communication master (it defines the start of each data word transfer), a data word transfer can only be started with valid data in the transmit buffer  $TBUF$ . In this case, the transmit shift register is loaded with the content of  $TBUF$ , that is not changed due to this action.
- If a USIC channel is a communication slave (it can not define the start itself, but has to react), a data word transfer requested by the communication master has to be started independently of the status of the data word in  $TBUF$ . If a data word transfer is requested and started by the master, the transmit shift register is loaded at the first corresponding shift clock edge either with the data word in  $TBUF$  (if it is valid for transmission) or with the level defined by bit  $SCTR.PDL$  (if the content of  $TBUF$  has not been valid at the transmission start). In both cases, the content of  $TBUF$  is not changed.

**Universal Serial Interface Channel (USIC)**

The control and status bits for the data validation are located in register TCSR. The data validation is based on the logic blocks shown in **Figure 15-18**.



**Figure 15-18 Transmit Data Validation**

- A transfer gating logic enables or disables the data word transfer from TBUF under software or under hardware control. If the input stage DX2 is not needed for data shifting, signal DX2S can be used for gating purposes. The transfer gating logic is controlled by bit field TCSR.TDEN.
- A transfer trigger logic supports data word transfers related to events, e.g. timer based or related to an input pin. If the input stage DX2 is not needed for data shifting, signal DX2T can be used for trigger purposes. The transfer trigger logic is controlled by bit TCSR.TDVTR and the occurrence of a trigger event is indicated by bit TCSR.TE. For example, this can be used for triggering the data transfer upon receiving the Clear to Send (CTS) signal at DX2 in the RS-232 protocol.
- A data validation logic combining the inputs from the gating logic, the triggering logic and DSU signals. A transmission of the data word located in TBUF can only be started if the gating enables the start, bit TCSR.TDV = 1, and bit TCSR.TE = 1. The content of the transmit buffer TBUF should not be overwritten with new data while it is valid for transmission and a new transmission can start. If the content of TBUF has to be changed, it is recommended to clear bit TCSR.TDV by writing  $FMR.MTDV = 10_B$  before updating the data. Bit TCSR.TDV becomes automatically set when TBUF is updated with new data. Another possibility are the interrupts TBI (for ASC and IIC) or RSI (for SSC and IIS) indicating that a transmission has started. While a transmission is in progress, TBUF can be loaded with new data. In this case the user has to take care that an update of the TBUF content takes place before a new transmission starts.

With this structure, the following data transfer functionality can be achieved:

**Universal Serial Interface Channel (USIC)**

- If bit TCSR.TDSSM = 0, the content of the transmit buffer TBUF is always considered as valid for transmission. The transfer trigger mechanism can be used to start the transfer of the same data word based on the selected event (e.g. on a timer base or an edge at a pin) to realize a kind of life-sign mechanism. Furthermore, in slave mode, it is ensured that always a correct data word is transmitted instead of the passive data level.
- Bit TCSR.TDSSM = 1 has to be programmed to allow word-by-word data transmission with a kind of single-shot mechanism. After each transmission start, a new data word has to be loaded into the transmit buffer TBUF, either by software write actions to one of the transmit buffer input locations TBUFx or by an optional data buffer (e.g. FIFO buffer). To avoid that data words are sent out several times or to allow data handling with an additional data buffer (e.g. FIFO), bit TCSR.TDSSM has to be 1.
- Bit TCSR.TDV becoming automatically set when a new data word is loaded into the transmit buffer TBUF, a transmission start can be requested by a write action of the data to be transmitted to at least the low byte of one of the transmit buffer input locations TBUFx. The additional information TCI can be used to control the data word length or other parameters independently for each data word by a single write access.
- Bit field FMR.MTDV allows software driven modification (set or clear) of bit TCSR.TDV. Together with the gating control bit field TCSR.TDEN, the user can set up the transmit data word without starting the transmission. A possible program sequence could be: clear TCSR.TDEN = 00<sub>B</sub>, write data to TBUFx, clear TCSR.TDV by writing FMR.MTDV = 10<sub>B</sub>, re-enable the gating with TCSR.TDEN = 01<sub>B</sub> and then set TCSR.TDV under software control by writing FMR.MTDV = 01<sub>B</sub>.

## 15.2.6 Operating the Receive Data Path

The receive data path is based on two sets of 16-bit wide receive shift registers RSR0[3:0] and RSR1[3:0] and a receive buffer for each of the set (RBUF0 and RBUF1). The data transfer parameters like data word length, data frame length, or the shift direction are controlled commonly for transmission and reception by the shift control registers.

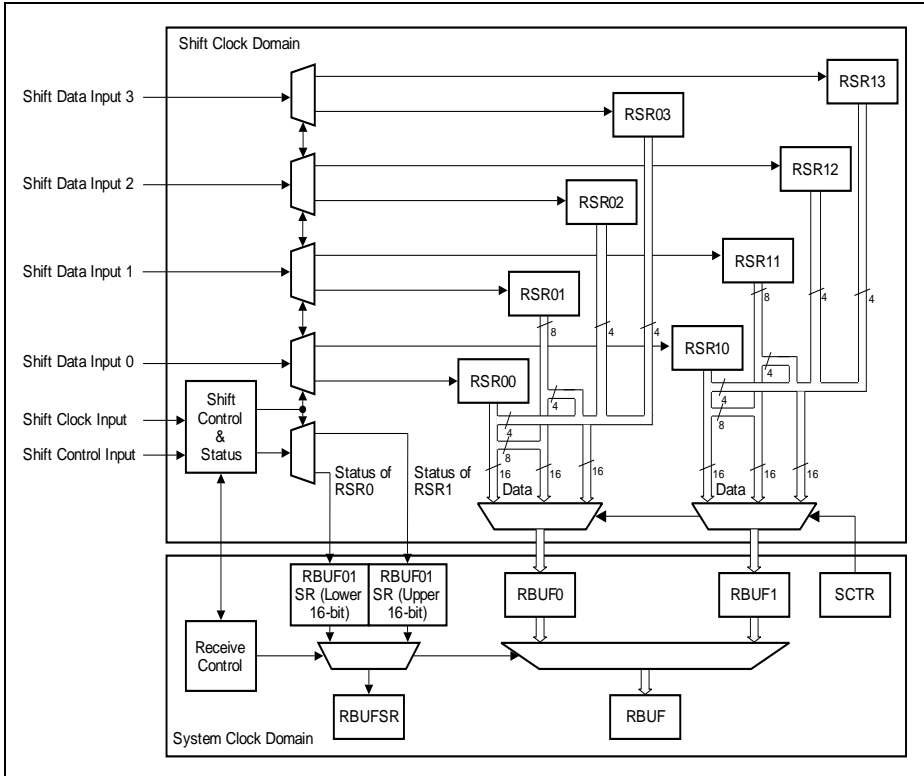
Register RBUF01SR monitors the status of RBUF0 and RBUF1.

### 15.2.6.1 Receive Buffering

The receive shift registers cannot be directly accessed by software, but their contents are automatically loaded into the receive buffer registers RBUF0 (or RBUF1 respectively) if a complete data word has been received or the frame is finished. The received data words in RBUF0 or RBUF1 can be read out in the correct order directly from register RBUF or, optionally, from a FIFO buffer stage (see [Page 15-38](#)).



**Universal Serial Interface Channel (USIC)**



**Figure 15-19 Receive Data Path**

**15.2.6.2 Receive Data Shift Mode**

Receive data can be selected to be shifted in one, two or four bits at a time through the corresponding number of input stages and data input lines. This option allows the USIC to support protocols such as the Dual- and Quad-SSC. The selection is done through the bit field DSM in the shift control register SCTR.

*Note: The bit field SCTR.DSM controls the data shift mode for both the transmit and receive paths to allow the transmission and reception of data through one to four data lines.*

For the shift mode with two or four parallel data inputs, the data word and frame length must be in multiples of two or four respectively. The number of data shifts required to input a specific data word or data frame length is thus reduced by the factor of the

## Universal Serial Interface Channel (USIC)

number of parallel data input lines. For example, to receive a 16-bit data word through four input lines, only four shifts are required.

Depending on the shift mode, different receive shift registers with different bit composition are used as shown in [Table 15-7](#). Note that the 'n' in the table denotes the shift number less one, i.e. for the first data shift  $n = 0$ , the second data shift  $n = 1$  and continues until the total number of shifts less one is reached.

For all receive shift registers, whether the first bit shifted in is the MSB or LSB depends on the setting of SCTR.SDIR.

**Table 15-8 Receive Shift Register Composition**

Receive Shift Registers	Input stage used	Single Data Input (SCTR.DSM = 00 <sub>B</sub> )	Two Data Inputs (SCTR.DSM = 10 <sub>B</sub> )	Four Data Inputs (SCTR.DSM = 11 <sub>B</sub> )
RSR <sub>x</sub> 0	DX0	All data bits	Bit $n*2$	Bit $n*4$
RSR <sub>x</sub> 1	DX3	Not used	Bit $n*2 + 1$	Bit $n*4 + 1$
RSR <sub>x</sub> 2	DX4	Not used	Not used	Bit $n*4 + 2$
RSR <sub>x</sub> 3	DX5	Not used	Not used	Bit $n*4 + 3$

### 15.2.6.3 Baud Rate Constraints

The following baud rate constraints have to be respected to ensure correct data reception and buffering. The user has to take care about these restrictions when selecting the baud rate and the data word length with respect to the module clock frequency  $f_{PB}$ .

- A received data word in a receiver shift registers RSR<sub>x</sub>[3:0] must be held constant for at least 4 periods of  $f_{PB}$  in order to ensure correct loading of the related receiver buffer register RBUF<sub>x</sub>.
- The shift control signal has to be constant inactive for at least 5 periods of  $f_{PB}$  between two consecutive frames in order to correctly detect the end of a frame.
- The shift control signal has to be constant active for at least 1 period of  $f_{PB}$  in order to correctly detect a frame (shortest frame).
- A minimum setup and hold time of the shift control signal with respect to the shift clock signal has to be ensured.

### 15.2.7 Hardware Port Control

Hardware port control is intended for SSC protocols with half-duplex configurations, where a single port pin is used for both input and output data functions, to control the pin direction through a dedicated hardware interface. All settings in Pn\_IOCry.PC<sub>x</sub>, except for the input pull device selection and output driver type (open drain or push-pull), are overruled by the hardware port control.

**Universal Serial Interface Channel (USIC)**

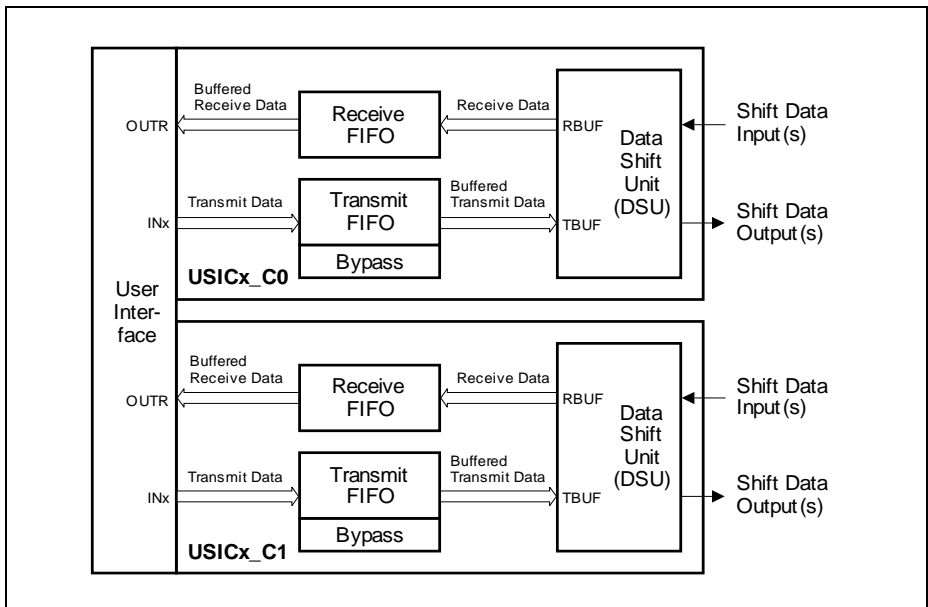
Input pull device selection is done through the Pn\_IOCRy.PC<sub>x</sub> as before, while the output driver is fixed to push-pull-only in this mode.

One, two or four port pins can be selected with the hardware port control to support SSC protocols with multiple bi-directional data lines, such as dual- and quad-SSC. This selection and the enable/disable of the hardware port control is done through CCR.HPCEN. The direction of all selected pins is controlled through a single bit SCTR.HPCDIR.

SCTR.HPCDIR is automatically shadowed with the start of each data word to prevent changing of the pin direction in the middle of a data word transfer.

**15.2.8 Operating the FIFO Data Buffer**

The FIFO data buffers of a USIC module are built in a similar way, with transmit buffer and receive buffer capability for each channel. Depending on the device, the amount of available FIFO buffer area can vary. In the XMC1200, totally 64 buffer entries can be distributed among the transmit or receive FIFO buffers of both channels of the USIC module.



**Figure 15-20 FIFO Buffer Overview**

In order to operate the FIFO data buffers, the following issues have to be considered:

---

**Universal Serial Interface Channel (USIC)**

- FIFO buffer available and selected:  
The transmit FIFO buffer and the bypass structure are only available if CCFG.TB = 1, whereas the receive FIFO buffer is only available if CCFG.RB = 1.  
It is recommended to configure all buffer parameters while there is no data traffic for this USIC channel and the FIFO mechanism is disabled by TBCTR.SIZE = 0 (for transmit buffer) or RBCTR.SIZE = 0 (for receive buffer). The allocation of a buffer area by writing TBCTR or RBCTR has to be done while the corresponding FIFO buffer is disabled. The FIFO buffer interrupt control bits can be modified independently of data traffic.
- FIFO buffer setup:  
The total amount of available FIFO buffer entries limits the length of the transmit and receive buffers for each USIC channel.
- Bypass setup:  
In addition to the transmit FIFO buffer, a bypass can be configured as described on [Page 15-49](#).

### 15.2.8.1 FIFO Buffer Partitioning

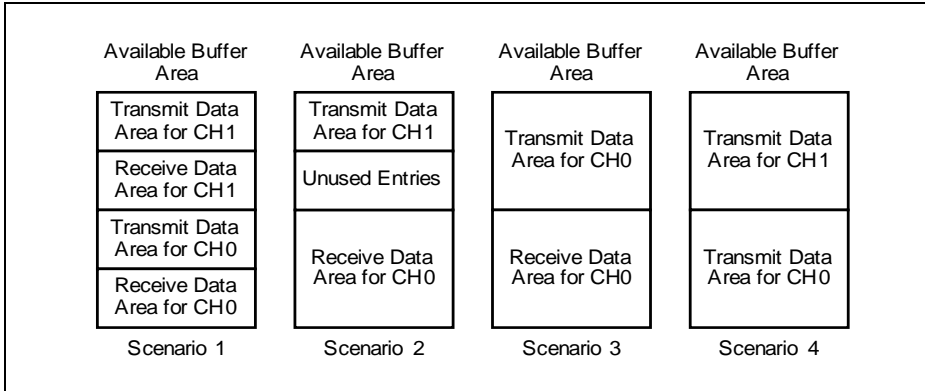
If available, the FIFO buffer area consists of a defined number of FIFO buffer entries, each containing a data part and the associated control information (RCI for receive data, TCI for transmit data). One FIFO buffer entry represents the finest granularity that can be allocated to a receive FIFO buffer or a transmit FIFO buffer. All available FIFO buffer entries of a USIC module are located one after the other in the FIFO buffer area. The overall counting starts with FIFO entry 0, followed by 1, 2, etc.

For each USIC module, a certain number of FIFO entries is available, that can be allocated to the channels of the same USIC module. It is not possible to assign FIFO buffer area to USIC channels that are not located within the same USIC module.

For each USIC channel, the size of the transmit and the receive FIFO buffer can be chosen independently. For example, it is possible to allocate the full amount of available FIFO entries as transmit buffer for one USIC channel. Some possible scenarios of FIFO buffer partitioning are shown in [Figure 15-21](#).

Each FIFO buffer consists of a set of consecutive FIFO entries. The size of a FIFO data buffer can only be programmed as a power of 2, starting with 2 entries, then 4 entries, then 8 entries, etc. A FIFO data buffer can only start at a FIFO entry aligned to its size. For example, a FIFO buffer containing  $n$  entries can only start with FIFO entry 0,  $n$ ,  $2*n$ ,  $3*n$ , etc. and consists of the FIFO entries  $[x*n, (x+1)*n-1]$ , with  $x$  being an integer number (incl. 0). It is not possible to have “holes” with unused FIFO entries within a FIFO buffer, whereas there can be unused FIFO entries between two FIFO buffers.

**Universal Serial Interface Channel (USIC)**



**Figure 15-21 FIFO Buffer Partitioning**

The data storage inside the FIFO buffers is based on pointers, that are internally updated whenever the data contents of the FIFO buffers have been modified. This happens automatically when new data is put into a FIFO buffer or the oldest data is taken from a FIFO buffer. As a consequence, the user program does not need to modify the pointers for data handling. Only during the initialization phase, the start entry of a FIFO buffer has to be defined by writing the number of the first FIFO buffer entry in the FIFO buffer to the corresponding bit field DPTR in register RBCTR (for a receive FIFO buffer) or TBCTR (for a transmit FIFO buffer) while the related bit field RBCTR.SIZE=0 (or TBCTR.SIZE = 0, respectively). The assignment of buffer entries to a FIFO buffer (regarding to size and pointers) must not be changed by software while the related USIC channel is taking part in data traffic.

### 15.2.8.2 Transmit Buffer Events and Interrupts

The transmit FIFO buffer mechanism detects the following events, that can lead to interrupts (if enabled):

- Standard transmit buffer event
- Transmit buffer error event

#### Standard Transmit Buffer Event

The standard transmit buffer event is triggered by the filling level of the transmit buffer (given by TRBSR.TBFLVL) exceeding (TBCTR.LOF = 1) or falling below (TBCTR.LOF = 0)<sup>1)</sup> a programmed limit (TBCTR.LIMIT).

<sup>1)</sup> If the standard transmit buffer event is used to indicate that new data has to be written to one of the INx locations, TBCTR.LOF = 0 should be programmed.

---

### Universal Serial Interface Channel (USIC)

If the event trigger with TRBSR.STBT feature is disabled (TBCTR.STBTEN = 0), the trigger of the standard transmit buffer event is based on the transition of the fill level from equal to below or above the limit, not the fact of being below or above.

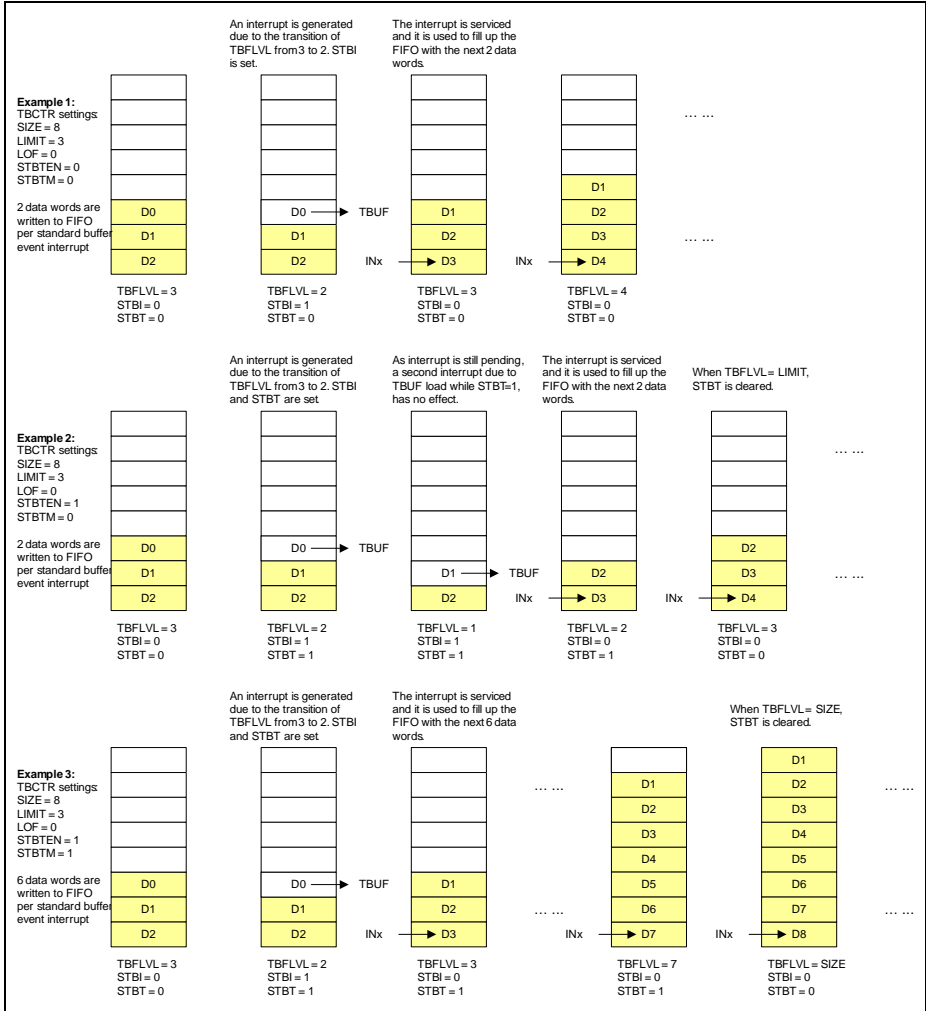
If TBCTR.STBTEN = 1, the transition of the fill level below or above the programmed limit additionally sets TRBSR.STBT. This bit triggers also the standard transmit buffer event whenever there is a transfer data to TBUF event or write data to INx event, depending on TBCTR.LOF setting.

The way TRBSR.STBT is cleared depends on the trigger mode (selected by TBCTR.STBTM). If TBCTR.STBTM = 0, TRBSR.STBT is cleared by hardware when the buffer fill level equals the programmed limit again (TRBSR.TBFLVL = TBCTR.LIMIT). If TBCTR.STBTM = 1, TRBSR.STBT is cleared by hardware when the buffer fill level equals the buffer size (TRBSR.TBFLVL = TBCTR.SIZE).

*Note: The flag TRBSR.STBI is set only when the transmit buffer fill level exceeds or falls below the programmed limit (depending on TBCTR.LOF setting). Standard transmit buffer events triggered by TRBSR.STBT does not set the flag.*

**Figure 15-22** shows examples of the standard transmit buffer event with the different TBCTR.STBTEN and TBCTR.STBTM settings. These examples are meant to illustrate the hardware behaviour and might not always represent real application use cases.

**Universal Serial Interface Channel (USIC)**



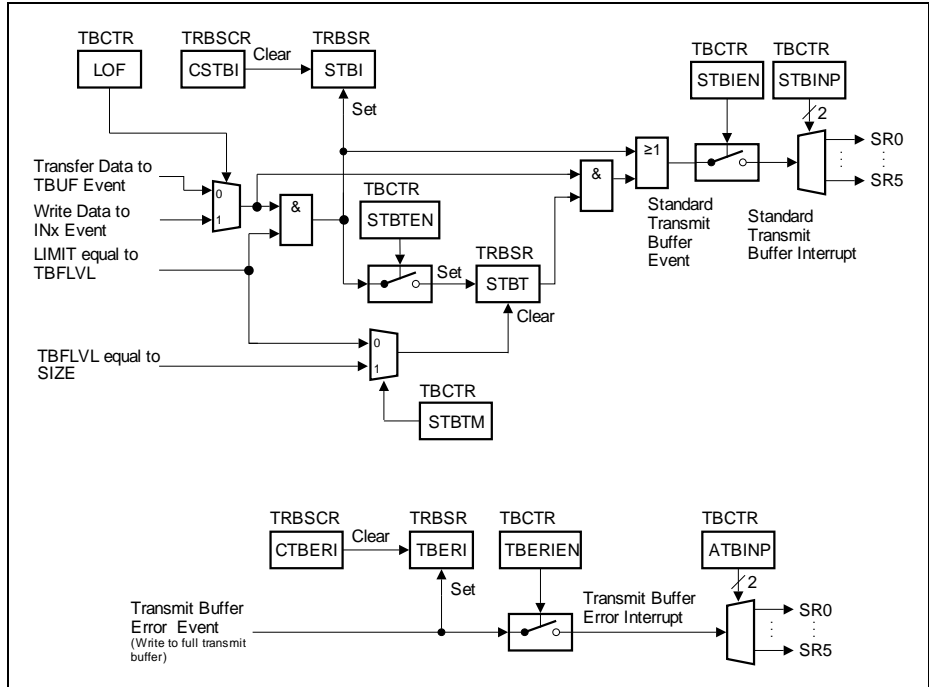
**Figure 15-22 Standard Transmit Buffer Event Examples**

**Transmit Buffer Error Event**

The transmit buffer error event is triggered when software has written to a full buffer. The written value is ignored.

**Transmit Buffer Events and Interrupt Handling**

Figure 15-23 shows the transmit buffer events and interrupts.



**Figure 15-23 Transmit Buffer Events**

Table 15-9 shows the registers, bits and bit fields to indicate the transmit buffer events and to control the interrupts related to the transmit FIFO buffers of a USIC channel.

**Table 15-9 Transmit Buffer Events and Interrupt Handling**

Event	Indication Flag	Indication cleared by	Interrupt enabled by	SRx Output selected by
Standard transmit buffer event	TRBSR. STBI	TRBSCR. CSTBI	TBCTR. STBIEN	TBCTR. STBINP
	TRBSR. STBT	Cleared by hardware		
Transmit buffer error event (Write to full transmit buffer)	TRBSR. TBERI	TRBSCR. CTBERI	TBCTR. TBERIEN	TBCTR. ATBINP



### 15.2.8.3 Receive Buffer Events and Interrupts

The receive FIFO buffer mechanism detects the following events, that can lead to an interrupt (if enabled):

- Standard receive buffer event
- Alternative receive buffer event
- Receive buffer error event

The standard receive buffer event and the alternative receive buffer event can be programmed to two different modes, one referring to the filling level of the receive buffer, the other one related to a bit position in the receive control information RCI of the data word that becomes available in OUTR.

If the interrupt generation refers to the filling level of the receive FIFO buffer, only the standard receive buffer event is used, whereas the alternative receive buffer event is not used. This mode can be selected to indicate that a certain amount of data has been received, without regarding the content of the associated RCI.

If the interrupt generation refers to RCI, the filling level is not taken into account. Each time a new data word becomes available in OUTR, an event is detected. If bit RCI[4] = 0, a standard receive buffer event is signaled, otherwise an alternative receive buffer device (RCI[4] = 1). Depending on the selected protocol and the setting of RBCTR.RCIM, the value of RCI[4] can hold different information that can be used for protocol-specific interrupt handling (see protocol sections for more details).

#### Standard Receive Buffer Event in Filling Level Mode

In filling level mode (RBCTR.RNM = 0), the standard receive buffer event is triggered by the filling level of the receive buffer (given by TRBSR.RBFLVL) exceeding (RBCTR.LOF = 1) or falling below (RBCTR.LOF = 0) a programmed limit (RBCTR.LIMIT).<sup>1)</sup>

If the event trigger with bit TRBSR.SRBT feature is disabled (RBCTR.SRBTEN = 0), the trigger of the standard receive buffer event is based on the transition of the fill level from equal to below or above the limit, not the fact of being below or above.

If RBCTR.SRBTEN = 1, the transition of the fill level below or above the programmed limit additionally sets the bit TRBSR.SRBT. This bit also triggers the standard receive buffer event each time there is a data read out event or new data received event, depending on RBCTR.LOF setting.

The way TRBSR.SRBT is cleared depends on the trigger mode (selected by RBCTR.SRBTM). If RBCTR.SRBTM = 0, TRBSR.SRBT is cleared by hardware when the buffer fill level equals the programmed limit again (TRBSR.RBFLVL =

---

<sup>1)</sup> If the standard receive buffer event is used to indicate that new data has to be read from OUTR, RBCTR.LOF = 1 should be programmed.

---

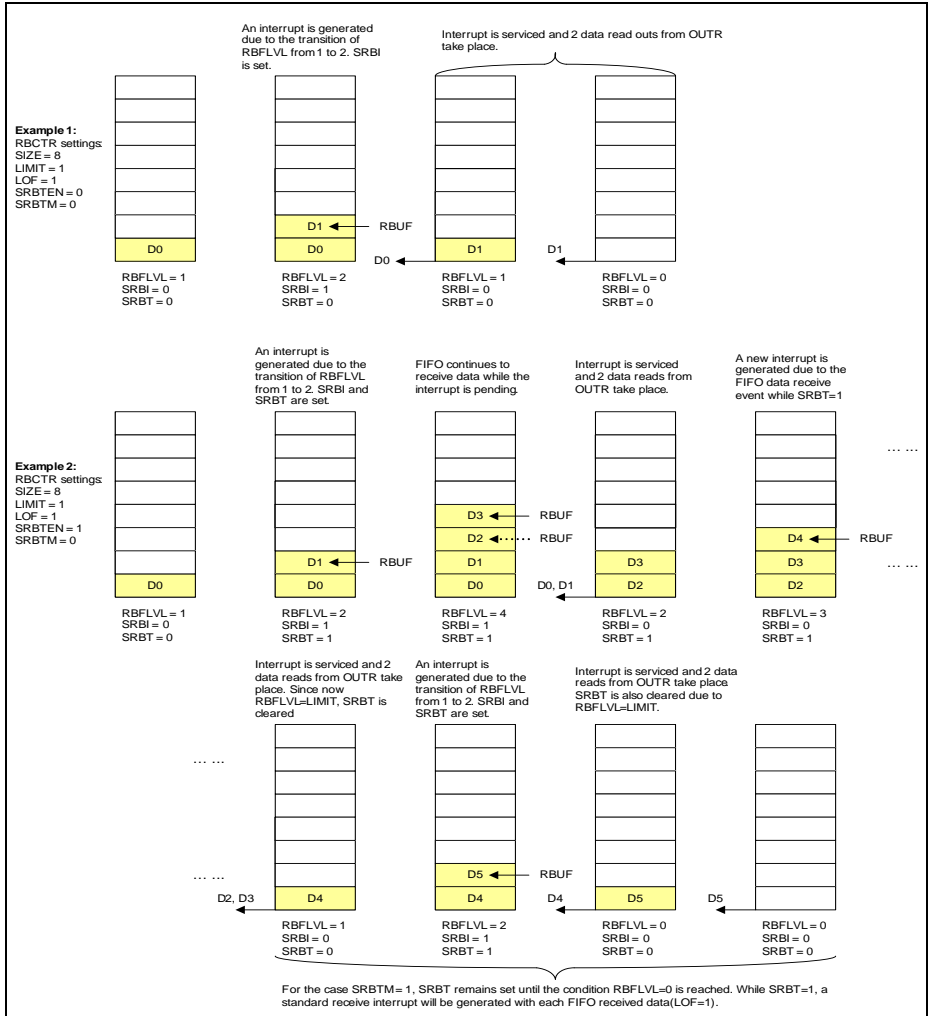
**Universal Serial Interface Channel (USIC)**

RBCTR.LIMIT). If RBCTR.SRBTM = 1, TRBSR.SRBT is cleared by hardware when the buffer fill level equals 0 (TRBSR.RBFLVL = 0).

*Note: The flag TRBSR.SRBI is set only when the receive buffer fill level exceeds or falls below the programmed limit (depending on RBCTR.LOF setting). Standard receive buffer events triggered by TRBSR.SRBT does not set the flag.*

**Universal Serial Interface Channel (USIC)**

**Figure 15-24** shows examples of the standard receive buffer event with the different RBCTR.SRBTEN and RBCTR.SRBTM settings. These examples are meant to illustrate the hardware behaviour and might not always represent real application use cases.



**Figure 15-24 Standard Receive Buffer Event Examples**

**Universal Serial Interface Channel (USIC)**

**Standard and Alternate Receive Buffer Events in RCI Mode**

In RCI mode (RBCTR.RNM = 1), the standard receive buffer event is triggered when the OUTR stage is updated with a new data value with RCI[4] = 0.

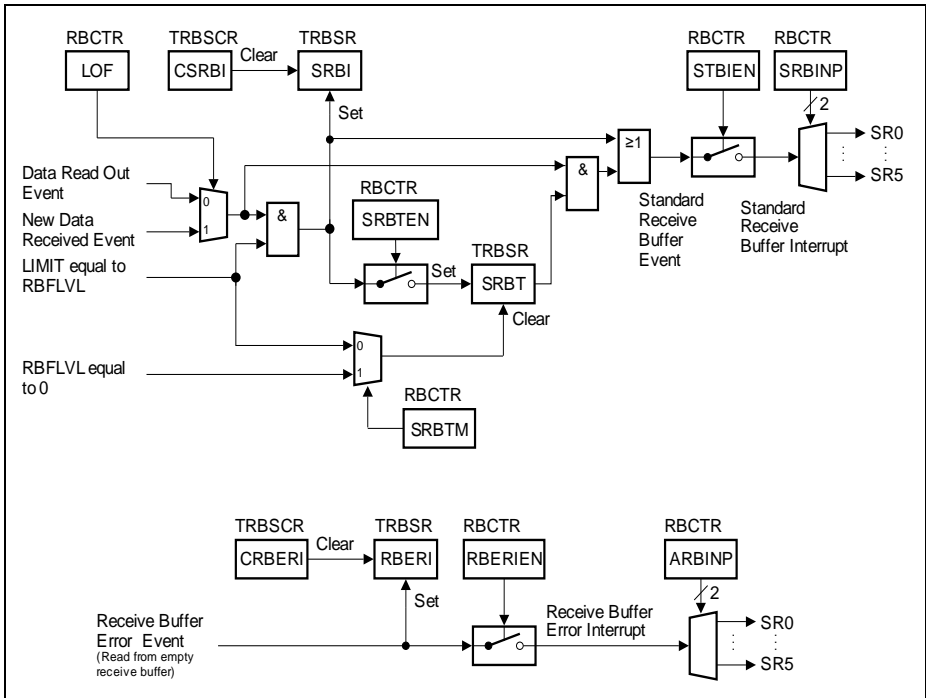
If the OUTR stage is updated with a new data value with RCI[4] = 1, an alternate receive buffer event is triggered instead.

**Receive Buffer Error Event**

The receive buffer error event is triggered if the software reads from an empty buffer, regardless of RBCTR.RNM value. The read data is invalid.

**Receive Buffer Events and Interrupt Handling**

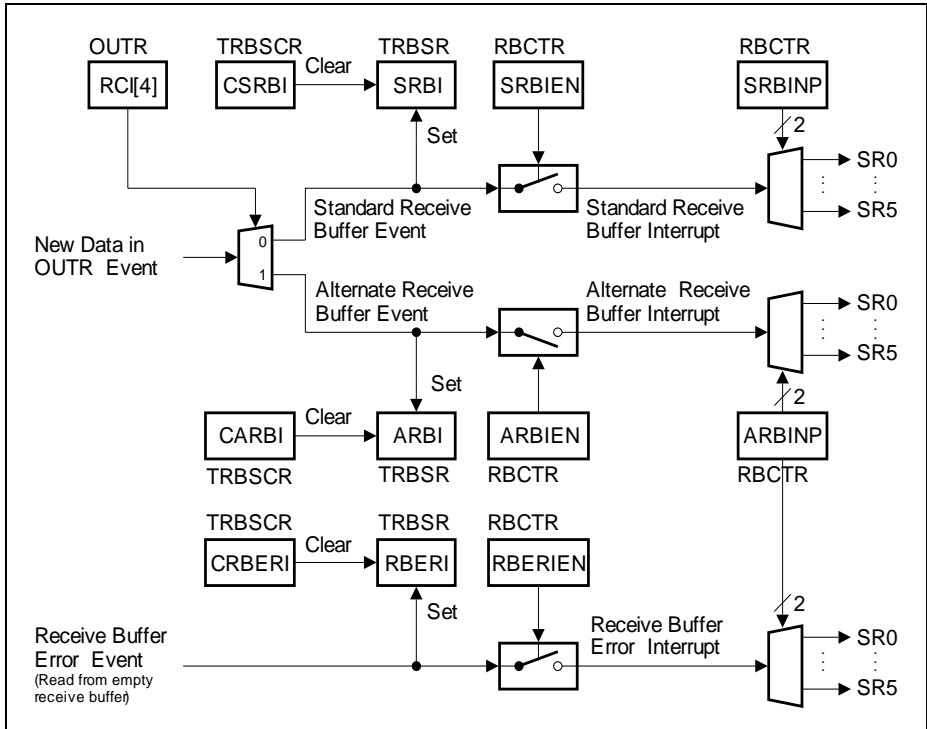
**Figure 15-25** shows the receiver buffer events and interrupts in filling level mode.



**Figure 15-25 Receiver Buffer Events in Filling Level Mode**

**Universal Serial Interface Channel (USIC)**

Figure 15-26 shows the receiver buffer events and interrupts in RCI mode.



**Figure 15-26 Receiver Buffer Events in RCI Mode**

Table 15-10 shows the registers, bits and bit fields to indicate the receive buffer events and to control the interrupts related to the receive FIFO buffers of a USIC channel.

**Table 15-10 Receive Buffer Events and Interrupt Handling**

Event	Indication Flag	Indication cleared by	Interrupt enabled by	SRx Output selected by
Standard receive buffer event	TRBSR. SRBI	TRBSCR. CSRBI	RBCTR. SRBIEN	RBCTR. SRBINP
	TRBSR. SRBT	Cleared by hardware		

**Universal Serial Interface Channel (USIC)**

**Table 15-10 Receive Buffer Events and Interrupt Handling (cont'd)**

<b>Event</b>	<b>Indication Flag</b>	<b>Indication cleared by</b>	<b>Interrupt enabled by</b>	<b>SRx Output selected by</b>
Alternative receive buffer event	TRBSR. ARBI	TRBSCR. CARBI	RBCTR. ARBIEN	RBCTR. ARBINP
Receive buffer error event	TRBSR. RBERI	TRBSCR. CRBERI	RBCTR. RBERIEN	RBCTR. ARBINTXDP

### 15.2.8.4 FIFO Buffer Bypass

The data bypass mechanism is part of the transmit FIFO control block. It allows to introduce a data word in the data stream without modifying the transmit FIFO buffer contents, e.g. to send a high-priority message. The bypass structure consists of a bypass data word of maximum 16 bits in register BYP and some associated control information in register BYPCR. For example, these bits define the word length of the bypass data word and configure a transfer trigger and gating mechanism similar to the one for the transmit buffer TBUF.

The bypass data word can be tagged valid or invalid for transmission by bit BYRCR.BDV (bypass data valid). A combination of data flow related and event related criteria define whether the bypass data word is considered valid for transmission. A data validation logic checks the start conditions for this data word. Depending on the result of the check, the transmit buffer register TBUF is loaded with different values, according to the following rules:

- Data from the transmit FIFO buffer or the bypass data can only be transferred to TBUF if TCSR.TDV = 0 (TBUF is empty).
- Bypass data can only be transferred to TBUF if the bypass is enabled by BYPCR.BDEN or the selecting gating condition is met.
- If the bypass data is valid for transmission and has either a higher transmit priority than the FIFO data or if the transmit FIFO is empty, the bypass data is transferred to TBUF.
- If the bypass data is valid for transmission and has a lower transmit priority than the FIFO buffer that contains valid data, the oldest transmit FIFO data is transferred to TBUF.
- If the bypass data is not valid for transmission and the FIFO buffer contains valid data, the oldest FIFO data is transferred to TBUF.
- If neither the bypass data is valid for transmission nor the transmit FIFO buffer contains valid data, TBUF is unchanged.

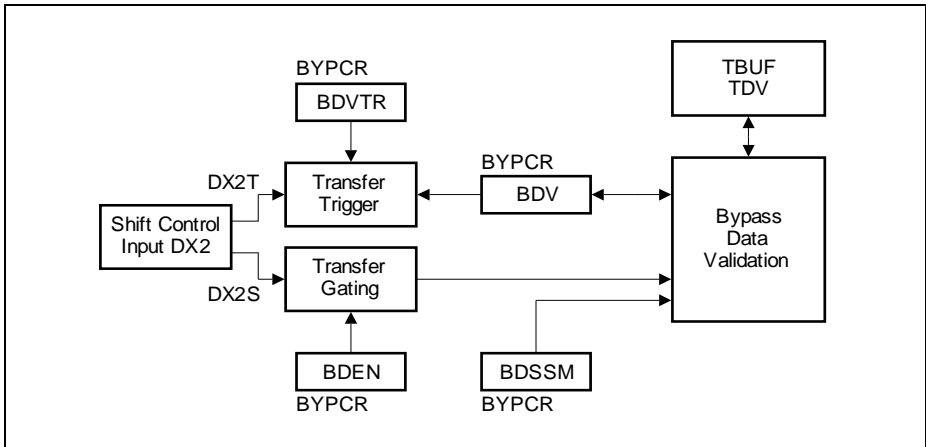
The bypass data validation is based on the logic blocks shown in [Figure 15-27](#).

- A transfer gating logic enables or disables the bypass data word transfer to TBUF under software or under hardware control. If the input stage DX2 is not needed for

**Universal Serial Interface Channel (USIC)**

data shifting, signal DX2S can be used for gating purposes. The transfer gating logic is controlled by bit field BYPCR.BDEN.

- A transfer trigger logic supports data word transfers related to events, e.g. timer based or related to an input pin. If the input stage DX2 is not needed for data shifting, signal DX2T can be used for trigger purposes. The transfer trigger logic is controlled by bit BYPCR.BDVTR.
- A bypass data validation logic combining the inputs from the gating logic, the triggering logic and TCSR.TDV.



**Figure 15-27 Bypass Data Validation**

With this structure, the following bypass data transfer functionality can be achieved:

- Bit BYPCR.BDSSM = 1 has to be programmed for a single-shot mechanism. After each transfer of the bypass data word to TBUF, the bypass data word has to be tagged valid again. This can be achieved either by writing a new bypass data word to BYP or by DX2T if BDVTR = 1 (e.g. trigger on a timer base or an edge at a pin).
- Bit BYPCR.BDSSM = 0 has to be programmed if the bypass data is permanently valid for transmission (e.g. as alternative data if the data FIFO runs empty).

**15.2.8.5 FIFO Access Constraints**

The data in the shared FIFO buffer area is accessed by the hardware mechanisms for data transfer of each communication channel (for transmission and reception) and by software to read out received data or to write data to be transmitted. As a consequence, the data delivery rate can be limited by the FIFO mechanism. Each access by hardware to the FIFO buffer area has priority over a software access, that is delayed in case of an access collision.

In order to avoid data loss and stalling of the CPU due to delayed software accesses, the

---

**Universal Serial Interface Channel (USIC)**

baud rate, the word length and the software access mechanism have to be taken into account. Each access to the FIFO data buffer area by software or by hardware takes one period of  $f_{PB}$ . Especially a continuous flow of very short, consecutive data words can lead to an access limitation.

**15.2.8.6 Handling of FIFO Transmit Control Information**

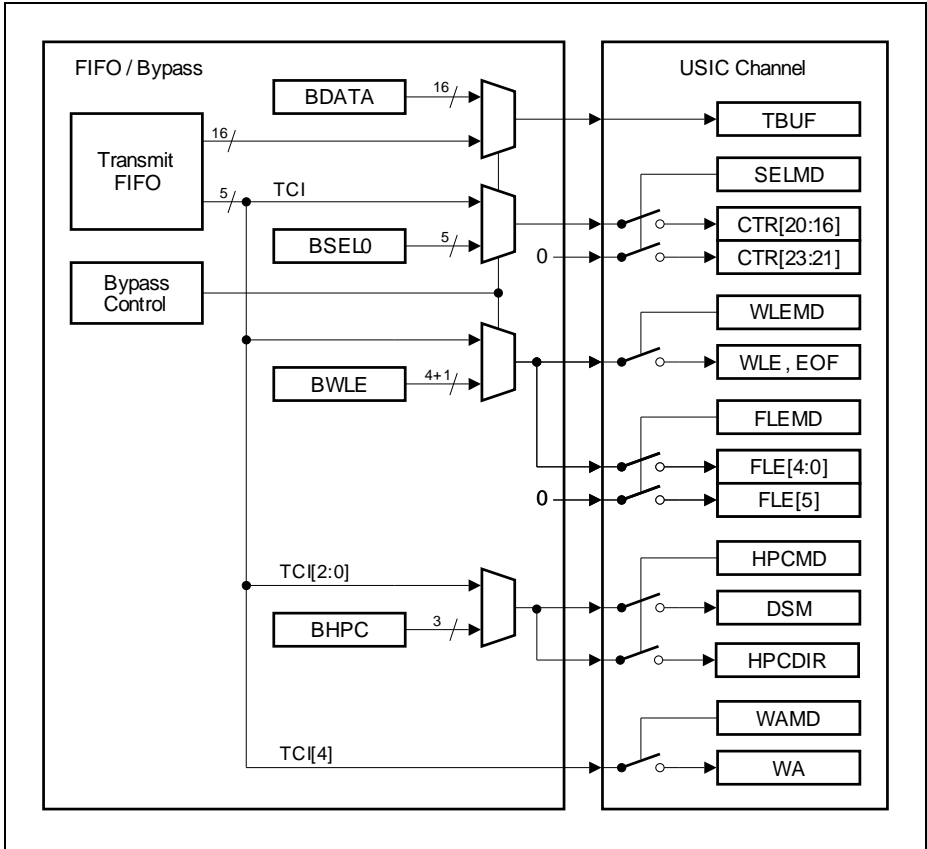
In addition to the transmit data, the transmit control information TCI can be transferred from the transmit FIFO or bypass structure to the USIC channel. Depending on the selected protocol and the enabled update mechanism, some settings of the USIC channel parameters can be modified. The modifications are based on the TCI of the FIFO data word loaded to TBUF or by the bypass control information if the bypass data is loaded into TBUF.

- TCSR.SELMD = 1: update of PCR.CTR[20:16] by FIFO TCI or BYPCR.BSELO with additional clear of PCR.CTR[23:21]
- TCSR.WLEMD = 1: update of SCTR.WLE and TCSR.EOF by FIFO TCI or BYPCR.BWLE (if the WLE information is overwritten by TCI or BWLE, the user has to take care that FLE is set accordingly)
- TCSR.FLEMD = 1: update of SCTR.FLE[4:0] by FIFO TCI or BYPCR.BWLE with additional clear of SCTR.FLE[5]
- TCSR.HPCMD = 1: update of SCTR.DSM and SCTR.HPCDIR by FIFO TCI or BYPCR.BHPC
- TCSR.WAMD = 1: update of TCSR.WA by FIFO TCI[4]

See [Section 15.2.5.3](#) for more details on TCI.



**Universal Serial Interface Channel (USIC)**



**Figure 15-28 TCI Handling with FIFO / Bypass**

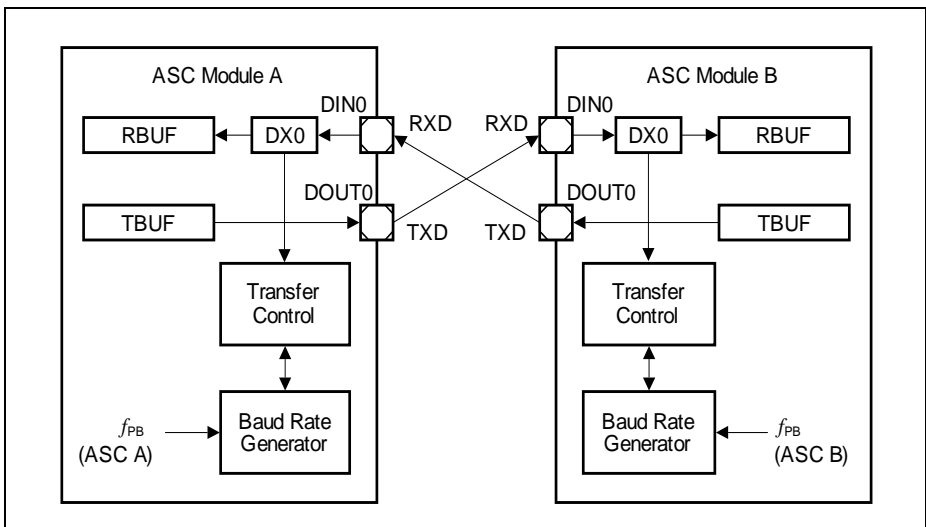
**Universal Serial Interface Channel (USIC)**

**15.3 Asynchronous Serial Channel (ASC = UART)**

The asynchronous serial channel ASC covers the reception and the transmission of asynchronous data frames and provides a hardware LIN support. The receiver and transmitter being independent, frames can start at different points in time for transmission and reception. The ASC mode is selected by  $CCR.MODE = 0010_B$  with  $CCFG.ASC = 1$  (ASC mode available).

**15.3.1 Signal Description**

An ASC connection is characterized by the use of a single connection line between a transmitter and a receiver. The receiver input RXD signal is handled by the input stage DX0.



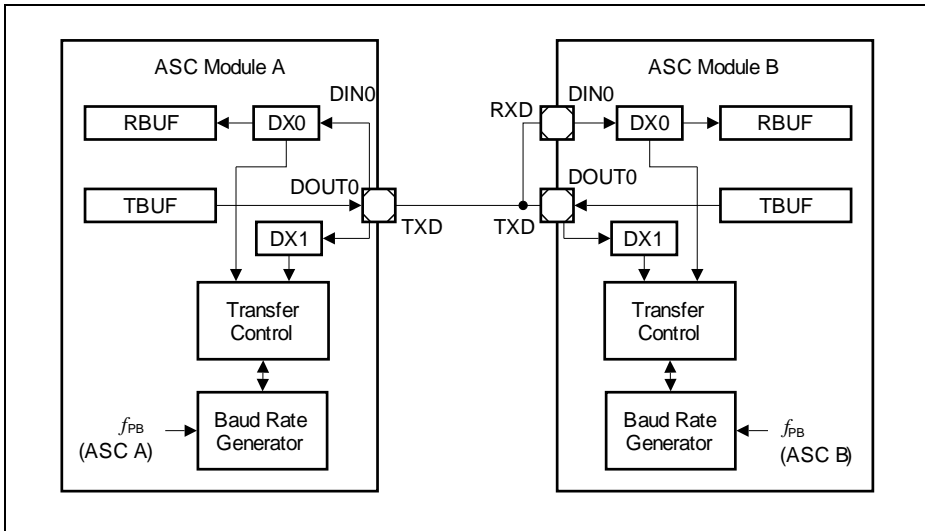
**Figure 15-29 ASC Signal Connections for Full-Duplex Communication**

For full-duplex communication, an independent communication line is needed for each transfer direction. **Figure 15-29** shows an example with a point-to-point full-duplex connection between two communication partners ASC A and ASC B.

For half-duplex or multi-transmitter communication, a single communication line is shared between the communication partners. **Figure 15-30** shows an example with a point-to-point half-duplex connection between ASC A and ASC B. In this case, the user has to take care that only one transmitter is active at a time. In order to support transmitter collision detection, the input stage DX1 can be used to monitor the level of the transmit line and to check if the line is in the idle state or if a collision occurred. There are two possibilities to connect the receiver input DINO to the transmitter output

**Universal Serial Interface Channel (USIC)**

DOUT0. Communication partner ASC A uses an internal connection with only the transmit pin TXD, that is delivering its input value as RXD to the DX0 input stage for reception and to DX1 to check for transmitter collisions. Communication partner ASC B uses an external connection between the two pins TXD and RXD.

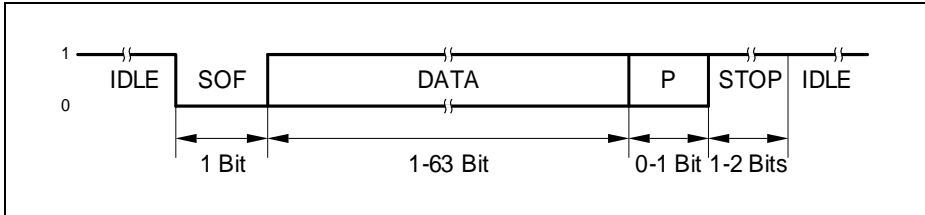


**Figure 15-30 ASC Signal Connections for Half-Duplex Communication**

**15.3.2 Frame Format**

A standard ASC frame is shown in [Figure 15-31](#). It consists of:

- An idle time with the signal level 1.
- One start of frame bit (SOF) with the signal level 0.
- A data field containing a programmable number of data bits (1-63).
- A parity bit (P), programmable for either even or odd parity. It is optionally possible to handle frames without parity bit.
- One or two stop bits with the signal level 1.



**Figure 15-31 Standard ASC Frame Format**

The protocol specific bits (SOF, P, STOP) are automatically handled by the ASC protocol state machine and do not appear in the data flow via the receive and transmit buffers.

### 15.3.2.1 Idle Time

The receiver and the transmitter independently check the respective data input lines (DX0, DX1) for being idle. The idle detection ensures that an SOF bit of a recently enabled ASC module does not collide with an already running frame of another ASC module.

In order to start the idle detection, the user software has to clear bits PSR.RXIDLE and/or PSR.TXIDLE, e.g. before selecting the ASC mode or during operation. If a bit is cleared by software while a data transfer is in progress, the currently running frame transfer is finished normally before starting the idle detection again. Frame reception is only possible if PSR.RXIDLE = 1 and frame transmission is only possible if PSR.TXIDLE = 1. The duration of the idle detection depends on the setting of bit PCR.IDM. In the case that a collision is not possible, the duration can be shortened and the bus can be declared as being idle by setting PCR.IDM = 0.

In the case that the complete idle detection is enabled by PCR.IDM = 1, the data input of DX0 is considered as idle (PSR.RXIDLE becomes set) if a certain number of consecutive passive bit times has been detected. The same scheme applies for the transmitter's data input of DX1. Here, bit PSR.TXIDLE becomes set if the idle condition of this input signal has been detected.

The duration of the complete idle detection is given by the number of programmed data bits per frame plus 2 (in the case without parity) or plus 3 (in the case with parity). The counting of consecutive bit times with 1 level restarts from the beginning each time an edge is found, after leaving a stop mode or if ASC mode becomes enabled.

If the idle detection bits PSR.RXIDLE and/or TXIDLE are cleared by software, the counting scheme is not stopped (no re-start from the beginning). As a result, the cleared bit(s) can become set immediately again if the respective input line still meets the idle criterion.

Please note that the idle time check is based on bit times, so the maximum time can be up to 1 bit time more than programmed value (but not less).

### 15.3.2.2 Start Bit Detection

The receiver input signal DIN0 (selected signal of input stage DX0) is checked for a falling edge. An SOF bit is detected when a falling edge occurs while the receiver is idle or after the sampling point of the last stop bit. To increase noise immunity, the SOF bit timing starts with the first falling edge that is detected. If the sampled bit value of the SOF is 1, the previous falling edge is considered to be due to noise and the receiver is considered to be idle again.

### 15.3.2.3 Data Field

The length of the data field (number of data bits) can be programmed by bit field SCTR.FLE. It can vary between 1 and 63 data bits, corresponding to values of SCTR.FLE = 0 to 62 (the value of 63 is reserved and must not be programmed in ASC mode).

The data field can consist of several data words, e.g. a transfer of 12 data bits can be composed of two 8-bit words, with the 12 bits being split into 8-bits of the first word and 4 bits of the second word. The user software has to take care that the transmit data is available in-time, once a frame has been started. If the transmit buffer runs empty during a running data frame, the passive data level (SCTR.PDL) is sent out.

The shift direction can be programmed by SCTR.SDIR. The standard setting for ASC frames with LSB first is achieved with the default setting SDIR = 0.

### 15.3.2.4 Parity Bit

The ASC allows parity generation for transmission and parity check for reception on frame base. The type of parity can be selected by bit field CCR.PM, common for transmission and reception (no parity, even or odd parity). If the parity handling is disabled, the ASC frame does not contain any parity bit. For consistency reasons, all communication partners have to be programmed to the same parity mode.

After the last data bit of the data field, the transmitter automatically sends out its calculated parity bit if parity generation has been enabled. The receiver interprets this bit as received parity and compares it to its internally calculated one. The received parity bit value and the result of the parity check are monitored in the receiver buffer status registers, RBUFSR and RBUF01SR, as receiver buffer status information. These registers contain bits to monitor a protocol-related argument (PAR) and protocol-related error indication (PERR).

### 15.3.2.5 Stop Bit(s)

Each ASC frame is completed by 1 or 2 of stop bits with the signal level 1 (same level as the idle level). The number of stop bits is programmable by bit PSR.STPB. A new start bit can be transferred directly after the last stop bit.

### 15.3.3 Operating the ASC

In order to operate the ASC protocol, the following issues have to be considered:

- **Select ASC mode:**  
It is recommended to configure all parameters of the ASC that do not change during run time while  $CCR.MODE = 0000_B$ . Bit field  $SCTR.TRM = 01_B$  has to be programmed. The configuration of the input stages has to be done while  $CCR.MODE = 0000_B$  to avoid unintended edges of the input signals and the ASC mode can be enabled by  $CCR.MODE = 0010_B$  afterwards.
- **Pin connections:**  
Establish a connection of input stage DX0 with the selected receive data input pin (signal DINO) with  $DX0CR.INSW = 0$  and configure a transmit data output pin (signal DOUT0). For collision or idle detection of the transmitter, the input stage DX1 has to be connected to the selected transmit output pin, also with  $DX1CR.INSW = 0$ . Additionally, program  $DX2CR.INSW = 0$ .  
Due to the handling of the input data stream by the synchronous protocol handler, the propagation delay of the synchronization in the input stage has to be considered.  
Note that the step to enable the alternate output port functions should only be done after the ASC mode is enabled, to avoid unintended spikes on the output.
- **Bit timing configuration:**  
The desired baud rate setting has to be selected, comprising the fractional divider, the baud rate generator and the bit timing. Please note that not all feature combinations can be supported by the application at the same time, e.g. due to propagation delays. For example, the length of a frame is limited by the frequency difference of the transmitter and the receiver device. Furthermore, in order to use the average of samples ( $SMD = 1$ ), the sampling point has to be chosen to respect the signal settling and data propagation times.
- **Data format configuration:**  
The word length, the frame length, and the shift direction have to be set up according to the application requirements by programming the register SCTR. If required by the application, the data input and output signals can be inverted.  
Additionally, the parity mode has to be configured ( $CCR.PM$ ).

#### 15.3.3.1 Bit Timing

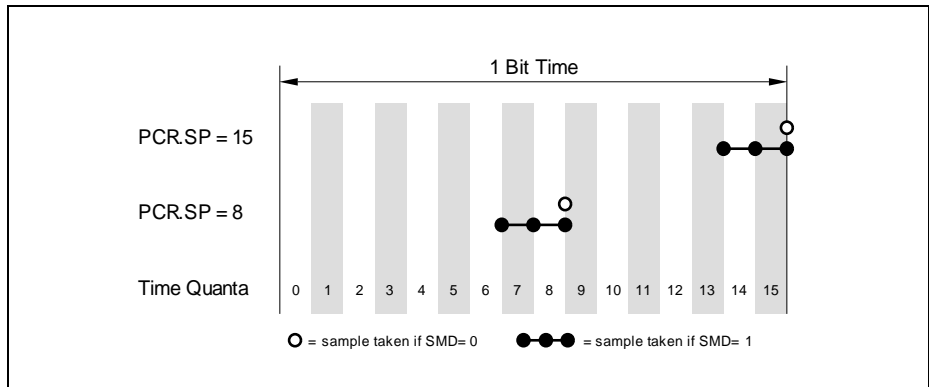
In ASC mode, each bit (incl. protocol bits) is divided into time quanta in order to provide granularity in the sub-bit range to adjust the sample point to the application requirements. The number of time quanta per bit is defined by bit fields  $BRG.DCTQ$  and the length of a time quantum is given by  $BRG.PCTQ$ .

In the example given in [Figure 15-32](#), one bit time is composed of 16 time quanta ( $BRG.DCTQ = 15$ ). It is not recommended to program less than 4 time quanta per bit time.

**Universal Serial Interface Channel (USIC)**

Bit field PCR.SP determines the position of the sampling point for the bit value. The value of PCR.SP must not be set to a value greater than BRG.DCTQ. It is possible to sample the bit value only once per bit time or to take the average of samples. Depending on bit PCR.SMD, either the current input value is directly sampled as bit value, or a majority decision over the input values sampled at the latest three time quanta is taken into account. The standard ASC bit timing consists of 16 time quanta with sampling after 8 or 9 time quanta with majority decision.

The bit timing setup (number of time quanta and the sampling point definition) is common for the transmitter and the receiver. Due to independent bit timing blocks, the receiver and the transmitter can be in different time quanta or bit positions inside their frames. The transmission of a frame is aligned to the time quanta generation.



**Figure 15-32 ASC Bit Timing**

The sample point setting has to be adjusted carefully if collision or idle detection is enabled (via DX1 input signal), because the driver delay and some external delays have to be taken into account. The sample point for the transmit line has to be set to a value where the bit level is stable enough to be evaluated.

If the sample point is located late in the bit time, the signal itself has more time to become stable, but the robustness against differences in the clock frequency of transmitter and receiver decreases.

**15.3.3.2 Baud Rate Generation**

The baud rate  $f_{ASC}$  in ASC mode depends on the number of time quanta per bit time and their timing. The baud rate setting should only be changed while the transmitter and the receiver are idle. The bits in register BRG define the baud rate setting:

- BRG.CTQSEL  
to define the input frequency  $f_{CTQIN}$  for the time quanta generation

**Universal Serial Interface Channel (USIC)**

- BRG.PCTQ  
to define the length of a time quantum (division of  $f_{CTQIN}$  by 1, 2, 3, or 4)
- BRG.DCTQ  
to define the number of time quanta per bit time

The standard setting is given by CTQSEL = 00<sub>B</sub> ( $f_{CTQIN} = f_{PDIV}$ ) and PPPEN = 0 ( $f_{PPP} = f_{PIN}$ ). Under these conditions, the baud rate is given by:

$$f_{ASC} = f_{PIN} \times \frac{1}{PDIV + 1} \times \frac{1}{PCTQ + 1} \times \frac{1}{DCTQ + 1} \quad (15.6)$$

In order to generate slower frequencies, two additional divide-by-2 stages can be selected by CTQSEL = 10<sub>B</sub> ( $f_{CTQIN} = f_{SCLK}$ ) and PPPEN = 1 ( $f_{PPP} = f_{MCLK}$ ), leading to:

$$f_{ASC} = \frac{f_{PIN}}{2 \times 2} \times \frac{1}{PDIV + 1} \times \frac{1}{PCTQ + 1} \times \frac{1}{DCTQ + 1} \quad (15.7)$$

### 15.3.3.3 Noise Detection

The ASC receiver permanently checks the data input line of the DX0 stage for noise (the check is independent from the setting of bit PCR.SMD). Bit PSR.RNS (receiver noise) becomes set if the three input samples of the majority decision are not identical at the sample point for the bit value. The information about receiver noise gets accumulated over several bits in bit PSR.RNS (it has to be cleared by software) and can trigger a protocol interrupt each time noise is detected if enabled by PCR.RNIEN.

### 15.3.3.4 Collision Detection

In some applications, such as data transfer over a single data line shared by several sending devices (see [Figure 15-30](#)), several transmitters have the possibility to send on the same data output line TXD. In order to avoid collisions of transmitters being active at the same time or to allow a kind of arbitration, a collision detection has been implemented.

The data value read at the TXD input at the DX1 stage and the transmitted data bit value are compared after the sampling of each bit value. If enabled by PCR.CDEN = 1 and a bit sent is not equal to the bit read back, a collision is detected and bit PSR.COL is set. If enabled, bit PSR.COL = 1 disables the transmitter (the data output lines become 1) and generates a protocol interrupt. The content of the transmit shift register is considered as invalid, so the transmit buffer has to be programmed again.

### 15.3.3.5 Pulse Shaping

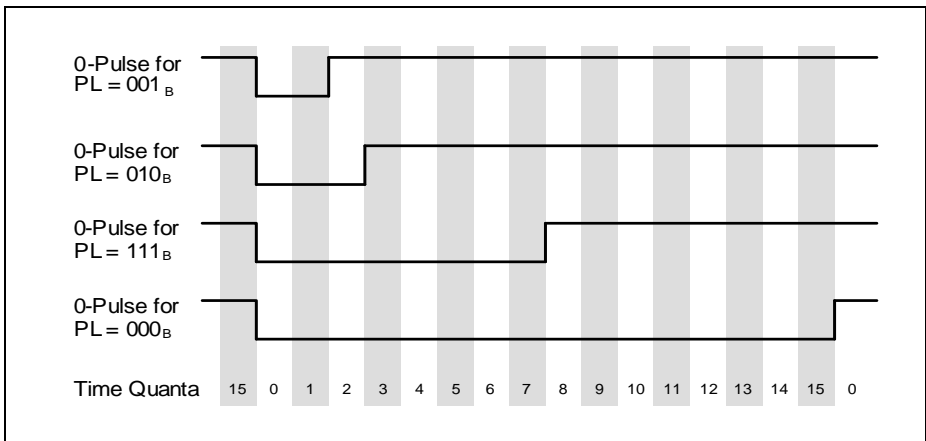
For some applications, the 0 level of transmitted bits with the bit value 0 is not applied at the transmit output during the complete bit time. Instead of driving the original 0 level,



**Universal Serial Interface Channel (USIC)**

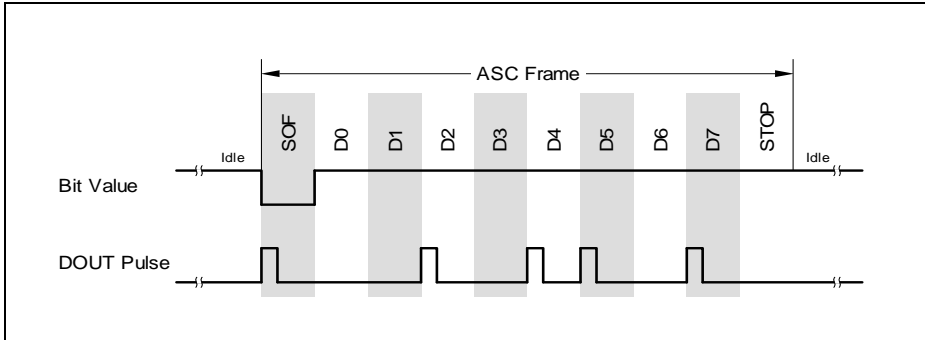
only a 0 pulse is generated and the remaining time quanta of the bit time are driven with 1 level. The length of a bit time is not changed by the pulse shaping, only the signalling is changed.

In the standard ASC signalling scheme, the 0 level is signalled during the complete bit time with bit value 0 (ensured by programming PCR.PL = 000<sub>B</sub>). In the case PCR.PL > 000<sub>B</sub>, the transmit output signal becomes 0 for the number of time quanta defined by PCR.PL. In order to support correct reception with pulse shaping by the transmitter, the sample point has to be adjusted in the receiver according to the applied pulse length.



**Figure 15-33 Transmitter Pulse Length Control**

**Figure 15-34** shows an example for the transmission of an 8-bit data word with LSB first and one stop bit (e.g. like for IrDA). The polarity of the transmit output signal has been inverted by SCTR.DOCFG = 01<sub>B</sub>.



**Figure 15-34 Pulse Output Example**

### 15.3.3.6 Automatic Shadow Mechanism

The contents of the protocol control register PCR, as well as bit field SCTR.FLE are internally kept constant while a data frame is transferred by an automatic shadow mechanism (shadowing takes place with each frame start). The registers can be programmed all the time with new settings that are taken into account for the next data frame. During a data frame, the applied (shadowed) setting is not changed, although new values have been written after the start of the data frame.

Bit fields SCTR.WLE and SCTR.SDIR are shadowed automatically with the start of each data word. As a result, a data frame can consist of data words with a different length. It is recommended to change SCTR.SDIR only when no data frame is running to avoid interference between hardware and software.

Please note that the starting point of a data word can be different for a transmitter and a receiver. In order to ensure correct handling, it is recommended to modify SCTR.WLE only while transmitter and receiver are both idle. If the transmitter and the receiver are referring to the same data signal (e.g. in a LIN bus system), SCTR.WLE can be modified while a data transfer is in progress after the RSI event has been detected.

### 15.3.3.7 End of Frame Control

The number of bits per ASC frame is defined by bit field SCTR.FLE. In order to support different frame length settings for consecutively transmitted frames, this bit field can be modified by hardware. The automatic update mechanism is enabled by TCSR.FLEMD = 1 (in this case, bits TCSR.WLEMD, SELMD, WAMD and HPCMD have to be written with 0).

If enabled, the transmit control information TCI automatically overwrites the bit field TCSR.FLEMD when the ASC frame is started (leading to frames with 1 to 32 data bits). The TCI value represents the written address location of TBUFxx (without additional data

---

**Universal Serial Interface Channel (USIC)**

buffer) or INxx (with additional data buffer). With this mechanism, an ASC with 8 data bits is generated by writing a data word to TBUF07 (IN07, respectively).

**15.3.3.8 Mode Control Behavior**

In ASC mode, the following kernel modes are supported:

- Run Mode 0/1:  
Behavior as programmed, no impact on data transfers.
- Stop Mode 0:  
Bit PSR.TXIDLE is cleared. A new transmission is not started. A current transmission is finished normally. Bit PSR.RXIDLE is not modified. Reception is still possible. When leaving stop mode 0, bit TXIDLE is set according to PCR.IDM.
- Stop Mode 1:  
Bit PSR.TXIDLE is cleared. A new transmission is not started. A current transmission is finished normally. Bit PSR.RXIDLE is cleared. A new reception is not possible. A current reception is finished normally. When leaving stop mode 1, bits TXIDLE and RXIDLE are set according to PCR.IDM.

**15.3.3.9 Disabling ASC Mode**

In order to switch off ASC mode without any data corruption, the receiver and the transmitter have to be both idle. This is ensured by requesting Stop Mode 1 in register KSCFG. After waiting for the end of the frame, the ASC mode can be disabled.

**15.3.3.10 Protocol Interrupt Events**

The following protocol-related events are generated in ASC mode and can lead to a protocol interrupt. The collision detection and the transmitter frame finished events are related to the transmitter, whereas the receiver events are given by the synchronization break detection, the receiver noise detection, the format error checks and the end of the received frame.

Please note that the bits in register PSR are not automatically cleared by hardware and have to be cleared by software in order to monitor new incoming events.

- Collision detection:  
This interrupt indicates that the transmitted value (DOUT0) does not match with the input value of the DX1 input stage at the sample point of a bit. For more details refer to [Page 15-59](#).
- Transmitter frame finished:  
This interrupt indicates that the transmitter has completely finished a frame. Bit PSR.TFF becomes set at the end of the last stop bit. The DOUT0 signal assignment to port pins can be changed while no transmission is in progress.
- Receiver frame finished:  
This interrupt indicates that the receiver has completely finished a frame. Bit

---

**Universal Serial Interface Channel (USIC)**

PSR.RFF becomes set at the end of the last stop bit. The DIN0 signal assignment to port pins can be changed while no reception is in progress.

- Synchronization break detection:  
This interrupt can be used in LIN networks to indicate the reception of the synchronization break symbol (at the beginning of a LIN frame).
- Receiver noise detection:  
This interrupt indicates that the input value at the sample point of a bit and at the two time quanta before are not identical.
- Format error:  
The bit value of the stop bit(s) is defined as 1 level for the ASC protocol. A format error is signalled if the sampled bit value of a stop bit is 0.

### 15.3.3.11 Data Transfer Interrupt Handling

The data transfer interrupts indicate events related to ASC frame handling.

- Transmit buffer interrupt TBI:  
Bit PSR.TBIF is set after the start of first data bit of a data word. This is the earliest point in time when a new data word can be written to TBUF.  
With this event, bit TCSR.TDV is cleared and new data can be loaded to the transmit buffer.
- Transmit shift interrupt TSI:  
Bit PSR.TSIF is set after the start of the last data bit of a data word.
- Receiver start interrupt RSI:  
Bit PSR.RSIF is set after the sample point of the first data bit of a data word.
- Receiver interrupt RI and alternative interrupt AI:  
Bit PSR.RIF is set after the sampling point of the last data bit of a data word if this data word is not directly followed by a parity bit (parity generation disabled or not the last word of a data frame).  
If the data word is directly followed by a parity bit (last data word of a data frame and parity generation enabled), bit PSR.RIF is set after the sampling point of the parity bit if no parity error has been detected. If a parity error has been detected, bit PSR.AIF is set instead of bit PSR.RIF.  
The first data word of a data frame is indicated by RBUF.SR.SOF = 1 for the received word.  
Bit PSR.RIF is set for a receiver interrupt RI with WA = 0. Bit PSR.AIF is set for a alternative interrupt AI with WA = 1.

### 15.3.3.12 Baud Rate Generator Interrupt Handling

The baud rate generator interrupt indicate that the capture mode timer has reached its maximum value. With this event, the bit PSR.BRGIF is set.

### 15.3.3.13 Protocol-Related Argument and Error

The protocol-related argument (RBUFSR.PAR) and the protocol-related error (RBUFSR.PERR) are two flags that are assigned to each received data word in the corresponding receiver buffer status registers.

In ASC mode, the received parity bit is monitored by the protocol-related argument and the result of the parity check by the protocol-related error indication (0 = received parity bit equal to calculated parity value). This information being elaborated only for the last received data word of each data frame, both bit positions are 0 for data words that are not the last data word of a data frame or if the parity generation is disabled.

### 15.3.3.14 Receive Buffer Handling

If a receive FIFO buffer is available (CCFG.RB = 1) and enabled for data handling (RBCTR.SIZE > 0), it is recommended to set RBCTR.RCIM = 11<sub>B</sub> in ASC mode. This leads to an indication that the data word has been the first data word of a new data frame if bit OUTR.RCI[0] = 1, a parity error is indicated by OUTR.RCI[4] = 1, and the received parity bit value is given by OUTR.RCI[3].

The standard receive buffer event and the alternative receive buffer event can be used for the following operations in RCI mode (RBCTR.RNM = 1):

- A standard receive buffer event indicates that a data word can be read from OUTR that has been received without parity error.
- An alternative receive buffer event indicates that a data word can be read from OUTR that has been received with parity error.

### 15.3.3.15 Sync-Break Detection

The receiver permanently checks the DIN0 signal for a certain number of consecutive bit times with 0 level. The number is given by the number of programmed bits per frame (SCTR.FLE) plus 2 (in the case without parity) or plus 3 (in the case with parity). If a 0 level is detected at a sample point of a bit after this event has been found, bit PSR.SBD is set and additionally, a protocol interrupt can be generated (if enabled by PCR.SBD = 1). The counting restarts from 0 each time a falling edge is found at input DIN0. This feature can be used for the detection of a synchronization break for slave devices in a LIN bus system (the master does not check for sync break).

For example, in a configuration for 8 data bits without parity generation, bit PCR.SBD is set after at the next sample point at 0 level after 10 complete bit times have elapsed (representing the sample point of the 11th bit time since the first falling edge).

### 15.3.3.16 Transfer Status Indication

The receiver status can be monitored by flag PSR[9] = BUSY if bit PCR.CTR[16] (receiver status enable RSTEN) is set. In this case, bit BUSY is set during a complete frame reception from the beginning of the start of frame bit to the end of the last stop bit.

**Universal Serial Interface Channel (USIC)**

The transmitter status can be monitored by flag PSR[9] = BUSY if bit PCR.CTR[17] (transmitter status enable TSTEN) is set. In this case, bit BUSY is set during a complete frame reception from the beginning of the start of frame bit to the end of the last stop bit. If both bits RSTEN and TSTEN are set, flag BUSY indicates the logical OR-combination of the receiver and the transmitter status. If both bits are cleared, flag BUSY is not modified depending on the transfer status (status changes are ignored).

**15.3.4 ASC Protocol Registers**

In ASC mode, the registers PCR and PSR handle ASC related information.

**15.3.4.1 ASC Protocol Control Register**

In ASC mode, the PCR register bits or bit fields are defined as described in this section.

**PCR**

**Protocol Control Register [ASC Mode]**

(3C<sub>H</sub>)

Reset Value: 0000 0000<sub>H</sub>

31	30	29	28	27	26	25	24	23	22	21	20	19	18	17	16			
MCLK															TSTEN	RSTEN		
rw	r														rw	rw		
15	14	13	12	11	10	9	8	7	6	5	4	3	2	1	0			
PL		SP				FFIEN	FEIEN	RNIEN	CDEEN	SBIEEN	IDM	STPB	SMD					
rw		rw				rw	rw	rw	rw	rw	rw	rw	rw	rw	rw			

Field	Bits	Type	Description
SMD	0	rw	<p><b>Sample Mode</b></p> <p>This bit field defines the sample mode of the ASC receiver. The selected data input signal can be sampled only once per bit time or three times (in consecutive time quanta). When sampling three times, the bit value shifted in the receiver shift register is given by a majority decision among the three sampled values.</p> <p>0<sub>B</sub> Only one sample is taken per bit time. The current input value is sampled.</p> <p>1<sub>B</sub> Three samples are taken per bit time and a majority decision is made.</p>

**Universal Serial Interface Channel (USIC)**

Field	Bits	Type	Description
<b>STPB</b>	1	rw	<p><b>Stop Bits</b></p> <p>This bit defines the number of stop bits in an ASC frame.</p> <p>0<sub>B</sub> The number of stop bits is 1.</p> <p>1<sub>B</sub> The number of stop bits is 2.</p>
<b>IDM</b>	2	rw	<p><b>Idle Detection Mode</b></p> <p>This bit defines if the idle detection is switched off or based on the frame length.</p> <p>0<sub>B</sub> The bus idle detection is switched off and bits PSR.TXIDLE and PSR.RXIDLE are set automatically to enable data transfers without checking the inputs before.</p> <p>1<sub>B</sub> The bus is considered as idle after a number of consecutive passive bit times defined by SCTR.FLE plus 2 (in the case without parity bit) or plus 3 (in the case with parity bit).</p>
<b>SBIEN</b>	3	rw	<p><b>Synchronization Break Interrupt Enable</b></p> <p>This bit enables the generation of a protocol interrupt if a synchronization break is detected. The automatic detection is always active, so bit SBD can be set independently of SBIEN.</p> <p>0<sub>B</sub> The interrupt generation is disabled.</p> <p>1<sub>B</sub> The interrupt generation is enabled.</p>
<b>CDEN</b>	4	rw	<p><b>Collision Detection Enable</b></p> <p>This bit enables the reaction of a transmitter to the collision detection.</p> <p>0<sub>B</sub> The collision detection is disabled.</p> <p>1<sub>B</sub> If a collision is detected, the transmitter stops its data transmission, outputs a 1, sets bit PSR.COL and generates a protocol interrupt. In order to allow data transmission again, PSR.COL has to be cleared by software.</p>
<b>RNIEN</b>	5	rw	<p><b>Receiver Noise Detection Interrupt Enable</b></p> <p>This bit enables the generation of a protocol interrupt if receiver noise is detected. The automatic detection is always active, so bit PSR.RNS can be set independently of PCR.RNIEN.</p> <p>0<sub>B</sub> The interrupt generation is disabled.</p> <p>1<sub>B</sub> The interrupt generation is enabled.</p>

**Universal Serial Interface Channel (USIC)**

Field	Bits	Type	Description
<b>FEIEN</b>	6	rw	<p><b>Format Error Interrupt Enable</b></p> <p>This bit enables the generation of a protocol interrupt if a format error is detected. The automatic detection is always active, so bits PSR.FER0/FER1 can be set independently of PCR.FEIEN.</p> <p>0<sub>B</sub> The interrupt generation is disabled. 1<sub>B</sub> The interrupt generation is enabled.</p>
<b>FFIEN</b>	7	rw	<p><b>Frame Finished Interrupt Enable</b></p> <p>This bit enables the generation of a protocol interrupt if the receiver or the transmitter reach the end of a frame. The automatic detection is always active, so bits PSR.RFF or PSR.TFF can be set independently of PCR.FFIEN.</p> <p>0<sub>B</sub> The interrupt generation is disabled. 1<sub>B</sub> The interrupt generation is enabled.</p>
<b>SP</b>	[12:8]	rw	<p><b>Sample Point</b></p> <p>This bit field defines the sample point of the bit value. The sample point must not be located outside the programmed bit timing (<math>PCR.SP \leq BRG.DCTQ</math>).</p>
<b>PL</b>	[15:13]	rw	<p><b>Pulse Length</b></p> <p>This bit field defines the length of a 0 data bit, counted in time quanta, starting with the time quantum 0 of each bit time. Each bit value that is a 0 can lead to a 0 pulse that is shorter than a bit time, e.g. for IrDA applications. The length of a bit time is not changed by PL, only the length of the 0 at the output signal.</p> <p>The pulse length must not be longer than the programmed bit timing (<math>PCR.PL \leq BRG.DCTQ</math>).</p> <p>This bit field is only taken into account by the transmitter and is ignored by the receiver.</p> <p>000<sub>B</sub> The pulse length is equal to the bit length (no shortened 0). 001<sub>B</sub> The pulse length of a 0 bit is 2 time quanta. 010<sub>B</sub> The pulse length of a 0 bit is 3 time quanta. ... 111<sub>B</sub> The pulse length of a 0 bit is 8 time quanta.</p>



**Universal Serial Interface Channel (USIC)**

Field	Bits	Type	Description
<b>RSTEN</b>	16	rw	<p><b>Receiver Status Enable</b></p> <p>This bit enables the modification of flag PSR[9] = BUSY according to the receiver status.</p> <p>0<sub>B</sub> Flag PSR[9] is not modified depending on the receiver status.</p> <p>1<sub>B</sub> Flag PSR[9] is set during the complete reception of a frame.</p>
<b>TSTEN</b>	17	rw	<p><b>Transmitter Status Enable</b></p> <p>This bit enables the modification of flag PSR[9] = BUSY according to the transmitter status.</p> <p>0<sub>B</sub> Flag PSR[9] is not modified depending on the transmitter status.</p> <p>1<sub>B</sub> Flag PSR[9] is set during the complete transmission of a frame.</p>
<b>MCLK</b>	31	rw	<p><b>Master Clock Enable</b></p> <p>This bit enables the generation of the master clock MCLK.</p> <p>0<sub>B</sub> The MCLK generation is disabled and the MCLK signal is 0.</p> <p>1<sub>B</sub> The MCLK generation is enabled.</p>
<b>0</b>	[30:18]	r	<p><b>Reserved</b></p> <p>Returns 0 if read; should be written with 0.</p>

### 15.3.4.2 ASC Protocol Status Register

In ASC mode, the PSR register bits or bit fields are defined as described in this section. The bits and bit fields in register PSR are not cleared by hardware.

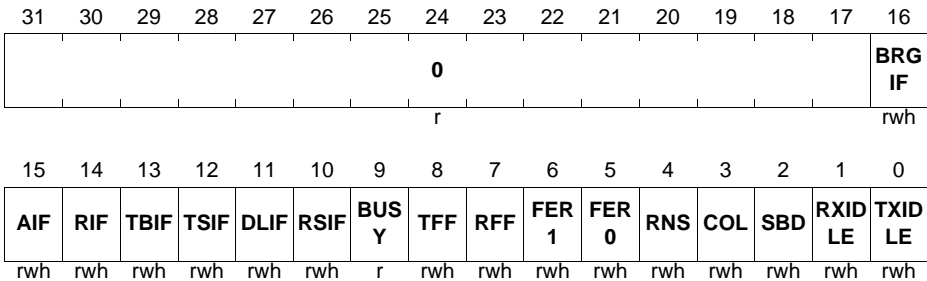
The flags in the PSR register can be cleared by writing a 1 to the corresponding bit position in register PSCR. Writing a 1 to a bit position in PSR sets the corresponding flag, but does not lead to further actions (no interrupt generation). Writing a 0 has no effect. The PSR flags should be cleared by software before enabling a new protocol.

**Universal Serial Interface Channel (USIC)**

**PSR**

**Protocol Status Register [ASC Mode] (48<sub>H</sub>)**

**Reset Value: 0000 0000<sub>H</sub>**



Field	Bits	Type	Description
<b>TXIDLE</b>	0	rwh	<p><b>Transmission Idle</b></p> <p>This bit shows if the transmit line (DX1) has been idle. A frame transmission can only be started if TXIDLE is set.</p> <p>0<sub>B</sub> The transmitter line has not yet been idle. 1<sub>B</sub> The transmitter line has been idle and frame transmission is possible.</p>
<b>RXIDLE</b>	1	rwh	<p><b>Reception Idle</b></p> <p>This bit shows if the receive line (DX0) has been idle. A frame reception can only be started if RXIDLE is set.</p> <p>0<sub>B</sub> The receiver line has not yet been idle. 1<sub>B</sub> The receiver line has been idle and frame reception is possible.</p>
<b>SBD</b>	2	rwh	<p><b>Synchronization Break Detected<sup>1)</sup></b></p> <p>This bit is set if a programmed number of consecutive bit values with level 0 has been detected (called synchronization break, e.g. in a LIN bus system).</p> <p>0<sub>B</sub> A synchronization break has not yet been detected. 1<sub>B</sub> A synchronization break has been detected.</p>
<b>COL</b>	3	rwh	<p><b>Collision Detected<sup>1)</sup></b></p> <p>This bit is set if a collision has been detected (with PCR.CDEN = 1).</p> <p>0<sub>B</sub> A collision has not yet been detected and frame transmission is possible. 1<sub>B</sub> A collision has been detected and frame transmission is not possible.</p>

**Universal Serial Interface Channel (USIC)**

<b>Field</b>	<b>Bits</b>	<b>Type</b>	<b>Description</b>
<b>RNS</b>	4	rwh	<b>Receiver Noise Detected<sup>1)</sup></b> This bit is set if receiver noise has been detected. 0 <sub>B</sub> Receiver noise has not been detected. 1 <sub>B</sub> Receiver noise has been detected.
<b>FER0</b>	5	rwh	<b>Format Error in Stop Bit 0<sup>1)</sup></b> This bit is set if a 0 has been sampled in the stop bit 0 (called format error 0). 0 <sub>B</sub> A format error 0 has not been detected. 1 <sub>B</sub> A format error 0 has been detected.
<b>FER1</b>	6	rwh	<b>Format Error in Stop Bit 1<sup>1)</sup></b> This bit is set if a 0 has been sampled in the stop bit 1 (called format error 1). 0 <sub>B</sub> A format error 1 has not been detected. 1 <sub>B</sub> A format error 1 has been detected.
<b>RFF</b>	7	rwh	<b>Receive Frame Finished<sup>1)</sup></b> This bit is set if the receiver has finished the last stop bit. 0 <sub>B</sub> The received frame is not yet finished. 1 <sub>B</sub> The received frame is finished.
<b>TFF</b>	8	rwh	<b>Transmitter Frame Finished<sup>1)</sup></b> This bit is set if the transmitter has finished the last stop bit. 0 <sub>B</sub> The transmitter frame is not yet finished. 1 <sub>B</sub> The transmitter frame is finished.
<b>BUSY</b>	9	r	<b>Transfer Status BUSY</b> This bit indicates the receiver status (if PCR.RSTEN = 1) or the transmitter status (if PCR.TSTEN = 1) or the logical OR combination of both (if PCR.RSTEN = PCR.TSTEN = 1). 0 <sub>B</sub> A data transfer does not take place. 1 <sub>B</sub> A data transfer currently takes place.
<b>RSIF</b>	10	rwh	<b>Receiver Start Indication Flag</b> 0 <sub>B</sub> A receiver start event has not occurred. 1 <sub>B</sub> A receiver start event has occurred.
<b>DLIF</b>	11	rwh	<b>Data Lost Indication Flag</b> 0 <sub>B</sub> A data lost event has not occurred. 1 <sub>B</sub> A data lost event has occurred.
<b>TSIF</b>	12	rwh	<b>Transmit Shift Indication Flag</b> 0 <sub>B</sub> A transmit shift event has not occurred. 1 <sub>B</sub> A transmit shift event has occurred.

**Universal Serial Interface Channel (USIC)**

Field	Bits	Type	Description
<b>TBIF</b>	13	rwh	<b>Transmit Buffer Indication Flag</b> 0 <sub>B</sub> A transmit buffer event has not occurred. 1 <sub>B</sub> A transmit buffer event has occurred.
<b>RIF</b>	14	rwh	<b>Receive Indication Flag</b> 0 <sub>B</sub> A receive event has not occurred. 1 <sub>B</sub> A receive event has occurred.
<b>AIF</b>	15	rwh	<b>Alternative Receive Indication Flag</b> 0 <sub>B</sub> An alternative receive event has not occurred. 1 <sub>B</sub> An alternative receive event has occurred.
<b>BRGIF</b>	16	rwh	<b>Baud Rate Generator Indication Flag</b> 0 <sub>B</sub> A baud rate generator event has not occurred. 1 <sub>B</sub> A baud rate generator event has occurred.
<b>0</b>	[31:17 ]	r	<b>Reserved</b> Returns 0 if read; should be written with 0.

1) This status bit can generate a protocol interrupt (see [Page 15-21](#)). The general interrupt status flags are described in the general interrupt chapter.

### 15.3.5 Hardware LIN Support

In order to support the LIN protocol, bit TCSR.FLEMD = 1 should be set for the master. For slave devices, it can be cleared and the fixed number of 8 data bits has to be set (SCTR.FLE = 7<sub>H</sub>). For both, master and slave devices, the parity generation has to be switched off (CCR.PM = 00<sub>B</sub>) and transfers take place with LSB first (SCTR.SDIR = 0) and 1 stop bit (PCR.STPB = 0).

The Local Interconnect Network (LIN) data exchange protocol contains several symbols that can all be handled in ASC mode. Each single LIN symbol represents a complete ASC frame. The LIN bus is a master-slave bus system with a single master and multiple slaves (for the exact definition please refer to the official LIN specification).

A complete LIN frame contains the following symbols:

- Synchronization break:

The master sends a synchronization break to signal the beginning of a new frame. It contains at least 13 consecutive bit times at 0 level, followed by at least one bit time at 1 level (corresponding to 1 stop bit). Therefore, TBUF11 if the transmit buffer is used, (or IN11 if the FIFO buffer is used) has to be written with 0 (leading to a frame with SOF followed by 12 data bits at 0 level).

A slave device shall detect 11 consecutive bit times at 0 level, which done by the synchronization break detection. Bit PSR.SBD is set if such an event is detected and a protocol interrupt can be generated. Additionally, the received data value of 0 appears in the receive buffer and a format error is signaled.

---

### Universal Serial Interface Channel (USIC)

If the baud rate of the slave has to be adapted to the master, the baud rate measurement has to be enabled for falling edges by setting  $BRG.TMEN = 1$ ,  $DX0CR.CM = 10_H$  and  $DX1CR.CM = 00_H$  before the next symbol starts.

- Synchronization byte:  
The master sends this symbol after writing the data value  $55_H$  to TBUF07 (or IN07). A slave device can either receive this symbol without any further action (and can discard it) or it can use the falling edges for baud rate measurement. Bit  $PSR.TSIF = 1$  (with optionally the corresponding interrupt) indicates the detection of a falling edge and the capturing of the elapsed time since the last falling edge in  $CMTR.CTV$ . Valid captured values can be read out after the second, third, fourth and fifth activation of  $TSIF$ . After the fifth activation of  $TSIF$  within this symbol, the baud rate detection can be disabled ( $BRG.TMEN = 0$ ) and  $BRG.PDIV$  can be programmed with the captured  $CMTR.CTV$  value divided by twice the number of time quanta per bit (assuming  $BRG.PCTQ = 00_B$ ).
- Other symbols:  
The other symbols of a LIN frame can be handled with ASC data frames without specific actions.

If LIN frames should be sent out on a frame base by the LIN master, the input  $DX2$  can be connected to external timers to trigger the transmit actions (e.g. the synchronization break symbol has been prepared but is started if a trigger occurs). Please note that during the baud rate measurement of the ASC receiver, the ASC transmitter of the same USIC channel can still perform a transmission.

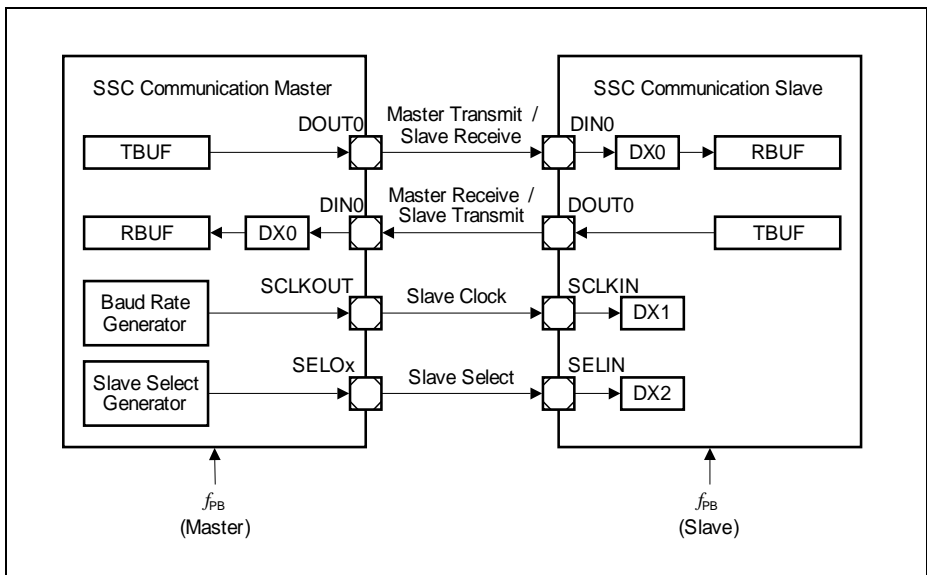
**Universal Serial Interface Channel (USIC)**

**15.4 Synchronous Serial Channel (SSC)**

The synchronous serial channel SSC covers the data transfer function of an SPI-like module. It can handle reception and transmission of synchronous data frames between a device operating in master mode and at least one device in slave mode. Besides the standard SSC protocol consisting of one input and one output data line, SSC protocols with two (Dual-SSC) or four (Quad-SSC) input/output data lines are also supported. The SSC mode is selected by  $CCR.MODE = 0001_B$  with  $CCFG.SSC = 1$  (SSC mode is available).

**15.4.1 Signal Description**

A synchronous SSC data transfer is characterized by a simultaneous transfer of a shift clock signal together with the transmit and/or receive data signal(s) to determine when the data is valid (definition of transmit and sample point).



**Figure 15-35 SSC Signals for Standard Full-Duplex Communication**

In order to explicitly indicate the start and the end of a data transfer and to address more than one slave devices individually, the SSC module supports the handling of slave select signals. They are optional and are not necessarily needed for SSC data transfers. The SSC module supports up to 8 different slave select output signals for master mode operation (named  $SELOx$ , with  $x = 0-7$ ) and 1 slave select input  $SELIN$  for slave mode. In most applications, the slave select signals are active low.

**Universal Serial Interface Channel (USIC)**

A device operating in master mode controls the start and end of a data frame, as well as the generation of the shift clock and slave select signals. This comprises the baud rate setting for the shift clock and the delays between the shift clock and the slave select output signals. If several SSC modules are connected together, there can be only one SSC master at a time, but several slaves. Slave devices receive the shift clock and optionally a slave select signal(s). For the programming of the input stages DXn please refer to [Page 15-21](#).

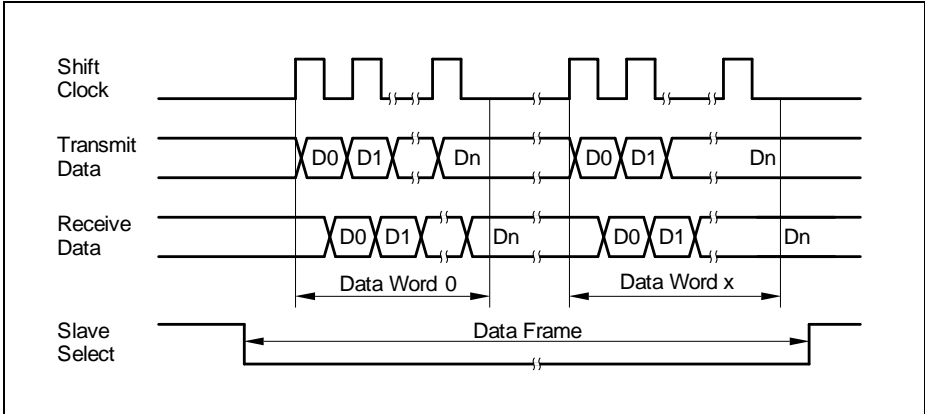
**Table 15-11 SSC Communication Signals**

SSC Mode	Receive Data	Transmit Data	Shift Clock	Slave Select(s)
Standard SSC Master	MRST <sup>1)</sup> , input DIN0, handled by DX0	MTSR <sup>2)</sup> , Output DOUT0	Output SCLKOUT	Output(s) SELOx
Standard SSC Slave	MTSR, input DIN0, handled by DX0	MRST, Output DOUT0	Input SCLKIN, handled by DX1	input SELIN, handled by DX2
Dual-SSC Master	MRST[1:0], input DIN[1:0], handled by DX0 and DX3	MTSR[1:0], Output DOUT[1:0]	Output SCLKOUT	Output(s) SELOx
Dual-SSC Slave	MTSR[1:0], input DIN[1:0], handled by DX0 and DX3	MRST[1:0], Output DOUT[1:0]	Input SCLKIN, handled by DX1	input SELIN, handled by DX2
Quad-SSC Master	MRST[3:0], input DIN[3:0], handled by DX0, DX3, DX4 and DX5	MTSR[3:0], Output DOUT[3:0]	Output SCLKOUT	Output(s) SELOx
Quad-SSC Slave	MTSR[3:0], input DIN[3:0], handled by DX0, DX3, DX4 and DX5	MRST[3:0], Output DOUT[3:0]	Input SCLKIN, handled by DX1	input SELIN, handled by DX2

1) MRST = master receive slave transmit, also known as MISO = master in slave out

2) MTSR = master transmit slave receive, also known as MOSI = master out slave in

**Universal Serial Interface Channel (USIC)**

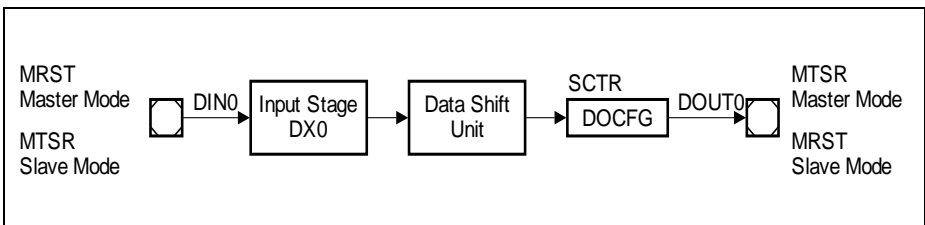


**Figure 15-36 4-Wire SSC Standard Communication Signals**

**15.4.1.1 Transmit and Receive Data Signals**

In standard SSC half-duplex mode, a single data line is used, either for data transfer from the master to a slave or from a slave to the master. In this case, MRST and MTSR are connected together, one signal as input, the other one as output, depending on the data direction. The user software has to take care about the data direction to avoid data collision (e.g. by preparing dummy data of all 1s for transmission in case of a wired AND connection with open-drain drivers, by enabling/disabling push/pull output drivers or by switching pin direction with hardware port control enabled). In full-duplex mode, data transfers take place in parallel between the master device and a slave device via two independent data signals MTSR and MRST, as shown in [Figure 15-35](#).

The receive data input signal DIN0 is handled by the input stage DX0. In master mode (referring to MRST) as well as in slave mode (referring to MTSR), the data input signal DIN0 is taken from an input pin. The signal polarity of DOUT0 (data output) with respect to the data bit value can be configured in block DOCFG (data output configuration) by bit field SCTR.DOCFG.



**Figure 15-37 SSC Data Signals**



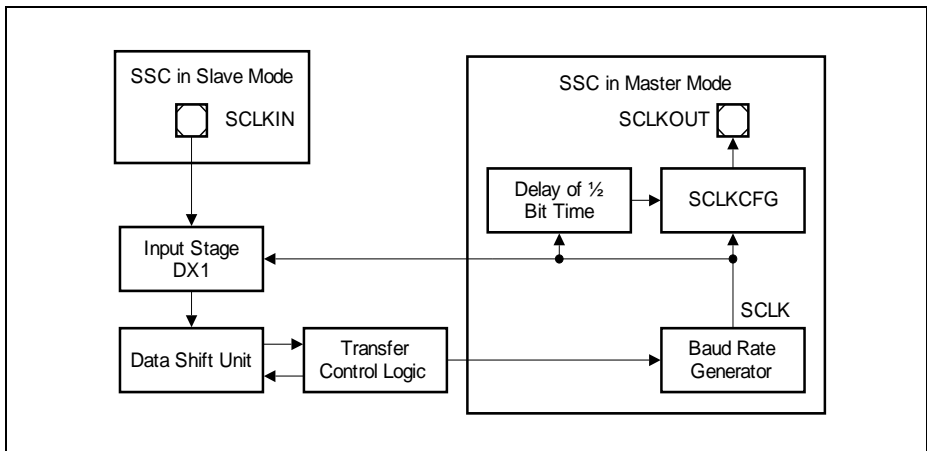
**Universal Serial Interface Channel (USIC)**

For dual- and quad-SSC modes that require multiple input and output data lines to be used, additional input stages, DINx and DOUTx signals need to be set up.

**15.4.1.2 Shift Clock Signals**

The shift clock signal is handled by the input stage DX1. In slave mode, the signal SCLKIN is received from an external master, so the DX1 stage has to be connected to an input pin. The input stage can invert the received input signal to adapt to the polarity of SCLKIN to the function of the data shift unit (data transmission on rising edges, data reception on falling edges).

In master mode, the shift clock is generated by the internal baud rate generator. The output signal SCLK of the baud rate generator is taken as shift clock input for the data shift unit. The internal signal SCLK is made available for external slave devices by signal SCLKOUT. For complete closed loop delay compensation in a slave mode, SCLKOUT can also take the transmit shift clock from the input stage DX1. The selection is done through the bit BRG.SCLKOSEL. See [Section 15.4.6.3](#).



**Figure 15-38 SSC Shift Clock Signals**

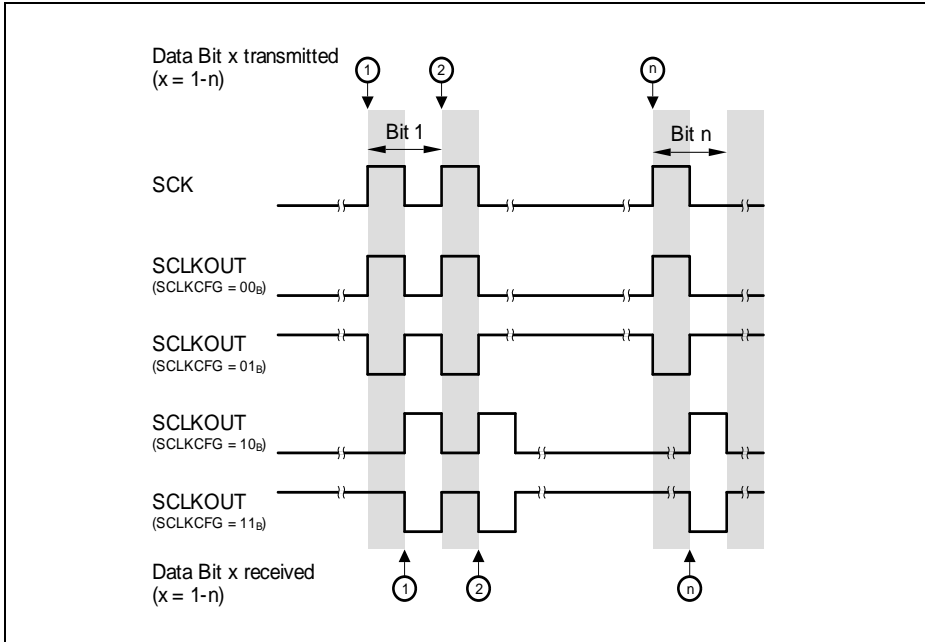
Due to the multitude of different SSC applications, in master mode, there are different ways to configure the shift clock output signal SCLKOUT with respect to SCLK. This is done in the block SCLKCFG (shift clock configuration) by bit field BRG.SCLKCFG, allowing 4 possible settings, as shown in [Figure 15-39](#).

- No delay, no polarity inversion (SCLKCFG = 00<sub>B</sub>, SCLKOUT equals SCLK):  
The inactive level of SCLKOUT is 0, while no data frame is transferred. The first data bit of a new data frame is transmitted with the first rising edge of SCLKOUT and the first data bit is received in with the first falling edge of SCLKOUT. The last data bit of a data frame is transmitted with the last rising clock edge of SCLKOUT and the last

**Universal Serial Interface Channel (USIC)**

data bit is received in with the last falling edge of SCLKOUT. This setting can be used in master and in slave mode. It corresponds to the behavior of the internal data shift unit.

- No delay, polarity inversion (SCLKCFG = 01<sub>B</sub>):  
The inactive level of SCLKOUT is 1, while no data frame is transferred. The first data bit of a new data frame is transmitted with the first falling clock edge of SCLKOUT and the first data bit is received with the first rising edge of SCLKOUT. The last data bit of a data frame is transmitted with the last falling edge of SCLKOUT and the last data bit is received with the last rising edge of SCLKOUT. This setting can be used in master and in slave mode.
- SCLKOUT is delayed by 1/2 shift clock period, no polarity inversion (SCLKCFG = 10<sub>B</sub>):  
The inactive level of SCLKOUT is 0, while no data frame is transferred.  
The first data bit of a new data frame is transmitted 1/2 shift clock period before the first rising clock edge of SCLKOUT. Due to the delay, the next data bits seem to be transmitted with the falling edges of SCLKOUT. The last data bit of a data frame is transmitted 1/2 period of SCLKOUT before the last rising clock edge of SCLKOUT. The first data bit is received 1/2 shift clock period before the first falling edge of SCLKOUT. Due to the delay, the next data bits seem to be received with the rising edges of SCLKOUT. The last data bit is received 1/2 period of SCLKOUT before the last falling clock edge of SCLKOUT.  
This setting can be used only in master mode and not in slave mode (the connected slave has to provide the first data bit before the first SCLKOUT edge, e.g. as soon as it is addressed by its slave select).
- SCLKOUT is delayed by 1/2 shift clock period, polarity inversion (SCLKCFG = 11<sub>B</sub>):  
The inactive level of SCLKOUT is 1, while no data frame is transferred.  
The first data bit of a new data frame is transmitted 1/2 shift clock period before the first falling clock edge of SCLKOUT. Due to the delay, the next data bits seem to be transmitted with the rising edges of SCLKOUT. The last data bit of a data frame is transmitted 1/2 period of SCLKOUT before the last falling clock edge of SCLKOUT. The first data bit is received 1/2 shift clock period before the first rising edge of SCLKOUT. Due to the delay, the next data bits seem to be received with the falling edges of SCLKOUT. The last data bit is received 1/2 period of SCLKOUT before the last rising clock edge of SCLKOUT.  
This setting can be used only in master mode and not in slave mode (the connected slave has to provide the first data bit before the first SCLKOUT edge, e.g. as soon as it is addressed by its slave select).



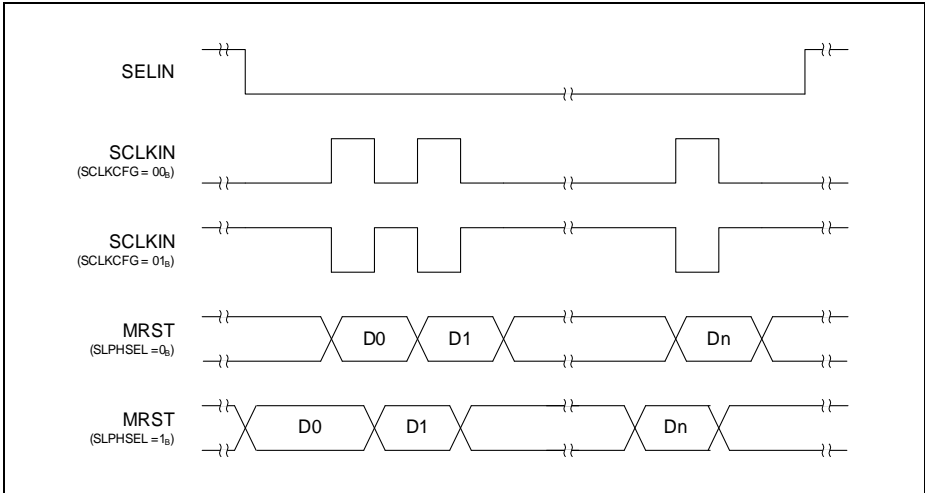
**Figure 15-39 SCLKOUT Configuration in SSC Master Mode**

*Note: If a configuration with delay is selected and a slave select line is used, the slave select delays have to be set up accordingly.*

In SSC slave mode, the bit PCR.SLPHSEL can be used to configure the clock phase of the data shift.

- When SLPHSEL = 0<sub>B</sub>, the slave SSC transmits data bits with each leading edge of the selected shift clock input (SCLKIN) and receives data bits with each trailing edge of SCLKIN
- When SLPHSEL = 1<sub>B</sub>, the slave SSC transmits the first data bit once the selected slave select input (SELIN) becomes active. If SELIN is not used, the DX2 stage has to deliver a 1-level to the data shift unit to shift out the first bit. Subsequent data bits are then transmitted with each trailing edge of SCLKIN. The SSC slave receives all data bits with each leading edge of SCLKIN.

For both settings, the clock polarity is determined by bit 0 of SCLKCFG.



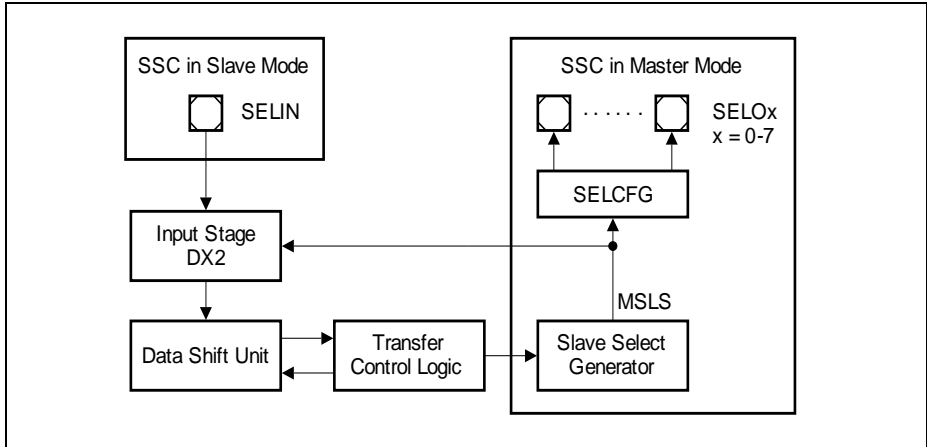
**Figure 15-40 SLPHSEL Configuration in SSC Slave Mode**

### 15.4.1.3 Slave Select Signals

The slave select signal is handled by the input stage DX2. In slave mode, the input signal SELIN is received from an external master via an input pin. The input stage can invert the received input signal to adapt the polarity of signal SELIN to the function of the data shift unit (the module internal signals are considered as high active, so a data transfer is only possible while the slave select input of the data shift unit is at 1-level, otherwise, shift clock pulses are ignored and do not lead to data transfers). If an input signal SELIN is low active, it should be inverted in the DX2 input stage.

In master mode, a master slave select signal MSLS is generated by the internal slave select generator. In order to address different external slave devices independently, the internal MSLS signal is made available externally via up to 8 SEL0x output signals that can be configured by the block SELCFG (select configuration).

**Universal Serial Interface Channel (USIC)**



**Figure 15-41 SSC Slave Select Signals**

The control of the SELCFG block is based on protocol specific bits and bit fields in the protocol control register PCR. For the generation of the MSLS signal please refer to [Section 15.4.3.2](#).

- PCR.SELCTR to chose between direct and coded select mode
- PCR.SELINV to invert the SELOx outputs
- PCR.SELO[7:0] as individual value for each SELOx line

The SELCFG block supports the following configurations of the SELOx output signals:

- Direct Select Mode (SELCTR = 1):  
Each SELOx line (with x = 0-7) can be directly connected to an external slave device. If bit x in bit field SELO is 0, the SELOx output is permanently inactive. A SELOx output becomes active while the internal signal MSLS is active (see [Section 15.4.3.2](#)) and bit x in bit field SELO is 1. Several external slave devices can be addressed in parallel if more than one bit in bit field SELO are set during a data frame. The number of external slave devices that can be addressed individually is limited to the number of available SELOx outputs.
- Coded Select Mode (SELCTR = 0):  
The SELOx lines (with x = 1-7) can be used as addresses for an external address decoder to increase the number of external slave devices. These lines only change with the start of a new data frame and have no other relation to MSLS. Signal SELO0 can be used as enable signal for the external address decoder. It is active while MSLS is active (during a data frame) and bit 0 in bit field SELO is 1. Furthermore, in coded select mode, this output line is delayed by one cycle of  $f_{PB}$  compared to MSLS to allow the other SELOx lines to stabilize before enabling the address decoder.

## 15.4.2 Operating the SSC

This chapter contains SSC issues, that are of general interest and not directly linked to either master mode or slave mode.

### 15.4.2.1 Automatic Shadow Mechanism

The contents of the baud rate control register BRG, bit fields SCTR.FLE as well as the protocol control register PCR are internally kept constant while a data frame is transferred (= while MSLS is active) by an automatic shadow mechanism. The registers can be programmed all the time with new settings that are taken into account for the next data frame. During a data frame, the applied (shadowed) setting is not changed, although new values have been written after the start of the data frame.

Bit fields SCTR.WLE, SCTR.DSM, SCTR.HPCDIR and SCTR.SDIR are shadowed automatically with the start of each data word. As a result, a data frame can consist of data words with a different length, or data words that are transmitted or received through different number of data lines. It is recommended to change SCTR.SDIR only when no data frame is running to avoid interference between hardware and software.

Please note that the starting point of a data word are different for a transmitter (first bit transmitted) and a receiver (first bit received). In order to ensure correct handling, it is recommended to refer to the receive start interrupt RSI before modifying SCTR.WLE. If TCSR.WLEMD = 1, it is recommended to update TCSR and TBUFxx after the receiver start interrupt has been generated.

### 15.4.2.2 Mode Control Behavior

In SSC mode, the following kernel modes are supported:

- Run Mode 0/1:  
Behavior as programmed, no impact on data transfers.
- Stop Mode 0/1:  
The content of the transmit buffer is considered as not valid for transmission. Although being considered as 0, bit TCSR.TDV it is not modified by the stop mode condition.  
In master mode, a currently running word transfer is finished normally, but no new data word is started (the stop condition is not considered as end-of-frame condition). In slave mode, a currently running word transfer is finished normally. Passive data will be sent out instead of a valid data word if a data word transfer is started by the external master while the slave device is in stop mode. In order to avoid passive slave transmit data, it is recommended not to program stop mode for an SSC slave device if the master device does not respect the slave device's stop mode.

### 15.4.2.3 Disabling SSC Mode

In order to disable SSC mode without any data corruption, the receiver and the transmitter have to be both idle. This is ensured by requesting Stop Mode 1 in register KSCFG. After Stop Mode 1 has been acknowledged by KSCFG.2 = 1, the SSC mode can be disabled.

### 15.4.2.4 Data Frame Control

An SSC data frame can consist of several consecutive data words that may be separated by an inter-word delay. Without inter-word delay, the data words seem to form a longer data word, being equivalent to a data frame. The length of the data words are most commonly identical within a data frame, but may also differ from one word to another. The data word length information (defined by SCTR.WLE) is evaluated for each new data word, whereas the frame length information (defined by SCTR.FLE) is evaluated at the beginning at each start of a new frame.

The length of an SSC data frame can be defined in two different ways:

- By the number of bits per frame:  
If the number of bits per data frame is defined (frame length FLE), a slave select signal is not necessarily required to indicate the start and the end of a data frame. If the programmed number of bits per frame is reached within a data word, the frame is considered as finished and remaining data bits in the last data word are ignored and are not transferred.  
This method can be applied for data frames with up to 63 data bits.
- By the slave select signal:  
If the number of bits per data frame is not known, the start/end information of a data frame is given by a slave select signal. If a deactivation of the slave select signal is detected within a data word, the frame is considered as finished and remaining data bits in the last data word are ignored and are not transferred.  
This method has to be applied for frames with more than 63 data bits (programming limit of FLE). The advantage of slave select signals is the clearly defined start and end condition of data frames in a data stream. Furthermore, slave select signals allow to address slave devices individually.

### 15.4.2.5 Parity Mode

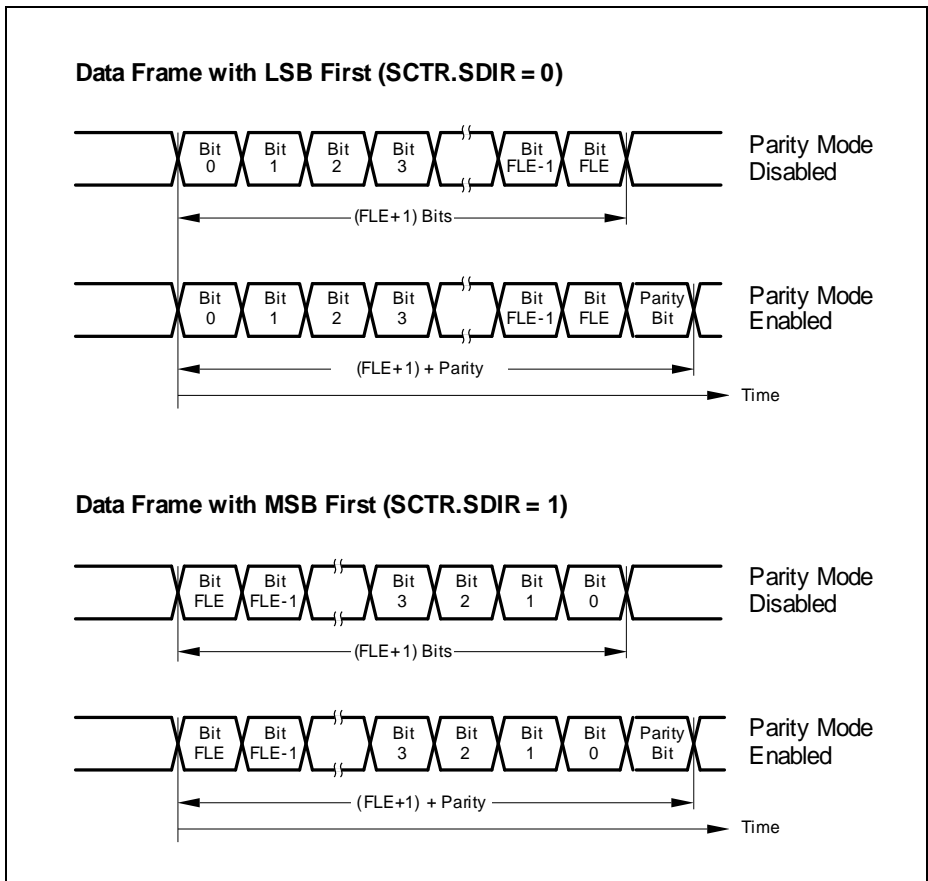
The SSC allows parity generation for transmission and parity check for reception on frame base. The type of parity can be selected by bit field CCR.PM, common for transmission and reception (no parity, even or odd parity). If the parity handling is disabled, the SSC frame does not contain any parity bit. For consistency reasons, all communication partners have to be programmed to the same parity mode.

**Universal Serial Interface Channel (USIC)**

If parity generation has been enabled, the transmitter automatically extends the clock by one cycle after the last data word of the data frame, and sends out its calculated parity bit in this cycle.

**Figure 15-42** shows how a parity bit is added to the transmitted data bits of a frame. The number of the transmitted bits of a complete frame with parity is always one more than that without parity. The parity bit is transmitted as the last bit of a frame, following the data bits, independent of the shift direction (SCTR.SDIR).

*Note: For dual and quad SSC protocols, the parity bit will be transmitted and received only on DOUT0 and DX0 respectively in the extended clock cycle.*



**Figure 15-42 Data Frames without/with Parity**



## Universal Serial Interface Channel (USIC)

Similarly, after the receiver receives the last word of a data frame as defined by FLE, it expects an additional one clock cycle, which will contain the parity bit. The receiver interprets this bit as received parity and separates it from the received data. The received parity bit value is instead monitored in the protocol-related argument (PAR) of the receiver buffer status registers as receiver buffer status information. The receiver compares the bit to its internally calculated parity and the result of the parity check is indicated by the flag PSR.PARERR. The parity error event generates a protocol interrupt if PCR.PARIEN = 1.

Parity bit generation and detection is not supported for the following cases:

- When frame length is 64 data bits or greater, i.e.  $FLE = 63_H$ ;
- When in slave mode, the end of frame occurs before the number of data bits defined by FLE is reached.

### 15.4.2.6 Transfer Mode

In SSC mode, bit field SCTR.TRM =  $01_B$  has to be programmed to allow data transfers. Setting SCTR.TRM =  $00_B$  disables and stops the data transfer immediately.

### 15.4.2.7 Data Transfer Interrupt Handling

The data transfer interrupts indicate events related to SSC frame handling.

- Transmit buffer interrupt TBI:  
Bit PSR.TBIF is set after the start of first data bit of a data word.
- Transmit shift interrupt TSI:  
Bit PSR.TSIF is set after the start of the last data bit of a data word.
- Receiver start interrupt RSI:  
Bit PSR.RSIF is set after the reception of the first data bit of a data word.  
With this event, bit TCSR.TDV is cleared and new data can be loaded to the transmit buffer.
- Receiver interrupt RI:  
The reception of the second, third, and all subsequent words in a multi-word frame is always indicated by RBUFSSR.SOF = 0. Bit PSR.RIF is set after the reception of the last data bit of a data word if RBUFSSR.SOF = 0.  
Bit RBUFSSR.SOF indicates whether the received data word has been the first data word of a multi-word frame or some subsequent word. In SSC mode, it decides if alternative interrupt or receive interrupt is generated.
- Alternative interrupt AI:  
The reception of the first word in a frame is always indicated by RBUFSSR.SOF = 1. This is true both in case of reception of multi-word frames and single-word frames. In SSC mode, this results in setting PSR.AIF.

### 15.4.2.8 Baud Rate Generator Interrupt Handling

The baud rate generator interrupt indicate that the capture mode timer has reached its maximum value. With this event, the bit PSR.BRGIF is set.

### 15.4.2.9 Protocol-Related Argument and Error

The protocol-related argument (RBUFSR.PAR) and the protocol-related error (RBUFSR.PERR) are two flags that are assigned to each received data word in the corresponding receiver buffer status registers.

In SSC mode, the received parity bit is monitored by the protocol-related argument. The received start of frame indication is monitored by the protocol-related error indication (0 = received word is not the first word of a frame, 1 = received word is the first word of a new frame).

*Note: For SSC, the parity error event indication bit is located in the PSR register.*

### 15.4.2.10 Receive Buffer Handling

If a receive FIFO buffer is available (CCFG.RB = 1) and enabled for data handling (RBCTR.SIZE > 0), it is recommended to set RBCTR.RCIM = 01<sub>B</sub> in SSC mode. This leads to an indication that the data word has been the first data word of a new data frame if bit OUTR.RCI[4] = 1, and the word length of the received data is given by OUTR.RCI[3:0].

The standard receive buffer event and the alternative receive buffer event can be used for the following operation in RCI mode (RBCTR.RNM = 1):

- A standard receive buffer event indicates that a data word can be read from OUTR that has not been the first word of a data frame.
- An alternative receive buffer event indicates that the first data word of a new data frame can be read from OUTR.

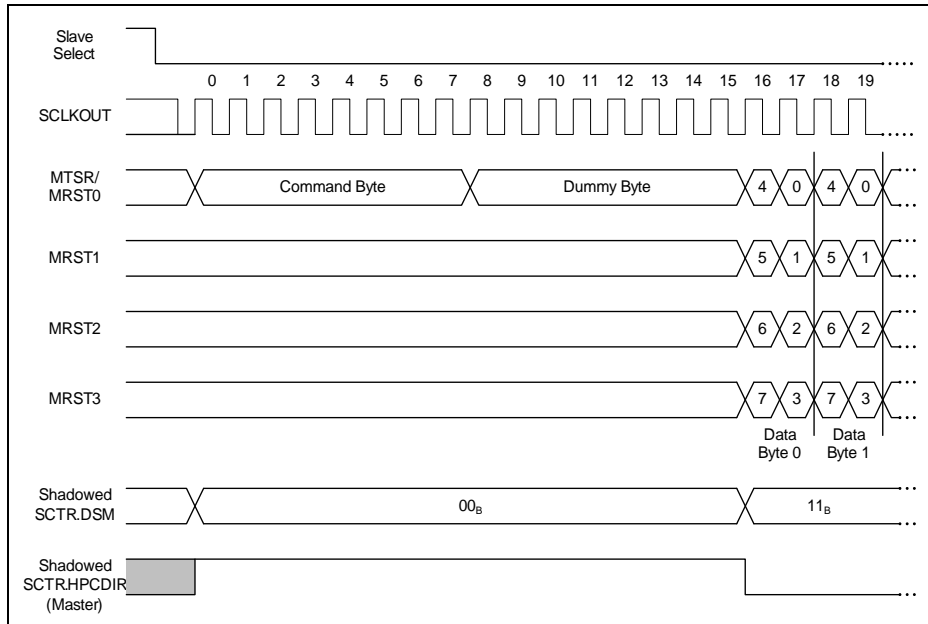
### 15.4.2.11 Multi-IO SSC Protocols

The SSC implements the following three features to support multiple data input/output SSC protocols, such as the dual- and quad-SSC:

1. Data Shift Mode ([Section 15.2.5.2](#))  
Configures the data for transmission and reception using one, two or four data lines in parallel, through the bit field SCTR.DSM.
2. Hardware Port Control ([Section 15.2.7](#))  
Sets up a dedicated hardware interface to control the direction of the pins overlaid with both DIN<sub>x</sub> and DOUT<sub>x</sub> functions, through the bit SCTR.HPCDIR.
3. Transmit Control Information ([Section 15.2.5.3](#))  
Allows the dynamic control of both the shift mode and pin direction during data transfers by writing to SCTR.DSM and SCTR.HPCDIR with TCI.

**Universal Serial Interface Channel (USIC)**

**Figure 15-43** shows an example of a Quad-SSC protocol, which requires the master SSC to first transmit a command byte (to request a quad output read from the slave) and a dummy byte through a single data line. At the end of the dummy byte, both master and slave SSC switches to quad data lines, and with the roles of transmitter and receiver reversed. The master SSC then receives the data four bits per shift clock from the slave through the MRST[3:0] lines.



**Figure 15-43 Quad-SSC Example**

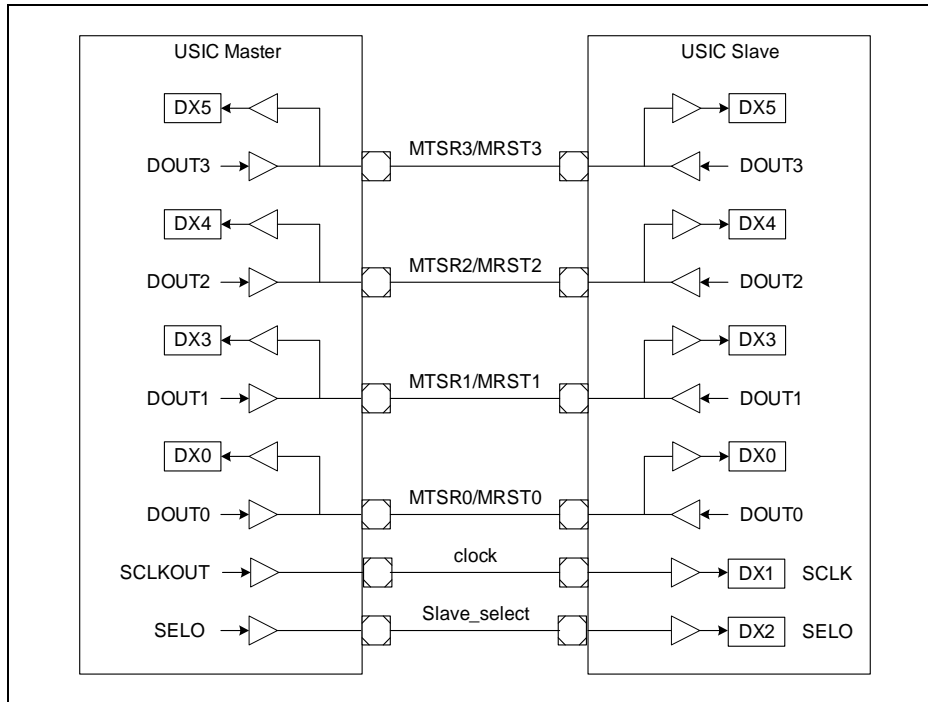
To work with the quad-SSC protocol in the given example, the following issues have to be additionally considered on top of those defined in [Section 15.4.3](#) and [Section 15.4.4](#):

- During the initialization phase:
  - Set CCR.HPCEN to  $11_B$  to enable the dedicated hardware interface to the DX0/DOUT0, DX3/DOUT1, DX4/DOUT2 and DX5/DOUT3 pins.
  - Set TCSR.[4:0] to  $10_H$  to enable hardware port control in TCI
- To start the data transfer:
  - For the master SSC, write the command and dummy bytes into TBUF04 to select a single data line in output mode and initiate the data transfer.
  - For the slave SSC, dummy data can be preloaded into TBUF00 to select a single data line in input mode.
- To switch to quad data lines and pin direction:

**Universal Serial Interface Channel (USIC)**

- For the master SSC, write subsequent dummy data to TBUF03 to select quad data lines in input mode to read in valid slave data.
- For the slave SSC, write valid data to TBUF07 for transmission through quad data lines in output mode.

Figure 15-44 shows the connections for the Quad-SSC example.



**Figure 15-44 Connections for Quad-SSC Example**

### 15.4.3 Operating the SSC in Master Mode

In order to operate the SSC in master mode, the following issues have to be considered:

- **Select SSC mode:**  
It is recommended to configure all parameters of the SSC that do not change during run time while  $CCR.MODE = 0000_B$ . Bit field  $SCTR.TRM = 01_B$  has to be programmed. The configuration of the input stages has to be done while  $CCR.MODE = 0000_B$  to avoid unintended edges of the input signals and the SSC mode can be enabled by  $CCR.MODE = 0001_B$  afterwards.
- **Pin connections:**  
Establish a connection of the input stage (DX0, DX3, DX4, DX5) with the selected

**Universal Serial Interface Channel (USIC)**

receive data input pin (DIN[3:0]) with DXnCR.INSW = 1 and configure the transmit data output pin (DOUT[3:0]). One, two or four such connections may be needed depending on the protocol. For half-duplex configurations, hardware port control can be also used to establish the required connections.

- **Baud rate generation:**  
The desired baud rate setting has to be selected, comprising the fractional divider and the baud rate generator. Bit DX1CR.INSW = 0 has to be programmed to use the baud rate generator output SCLK directly as input for the data shift unit. Configure a shift clock output pin (signal SCLKOUT).
- **Slave select generation:**  
The slave select delay generation has to be enabled by setting PCR.MSLSEN = 1 and the programming of the time quanta counter setting. Bit DX2CR.INSW = 0 has to be programmed to use the slave select generator output MSLS as input for the data shift unit. Configure slave select output pins (signals SELOx) if needed.
- **Data format configuration:**  
The word length, the frame length, the shift direction and shift mode have to be set up according to the application requirements by programming the register SCTR.

*Note: The USIC can only receive in master mode if it is transmitting, because the master frame handling refers to bit TDV of the transmitter part.*

*Note: The step to enable the alternate output port functions should only be done after the SSC mode is enabled, to avoid unintended spikes on the output.*

**15.4.3.1 Baud Rate Generation**

The baud rate (determining the length of one data bit) of the SSC is defined by the frequency of the SCLK signal (one period of  $f_{SCLK}$  represents one data bit). The SSC baud rate generation does not imply any time quanta counter.

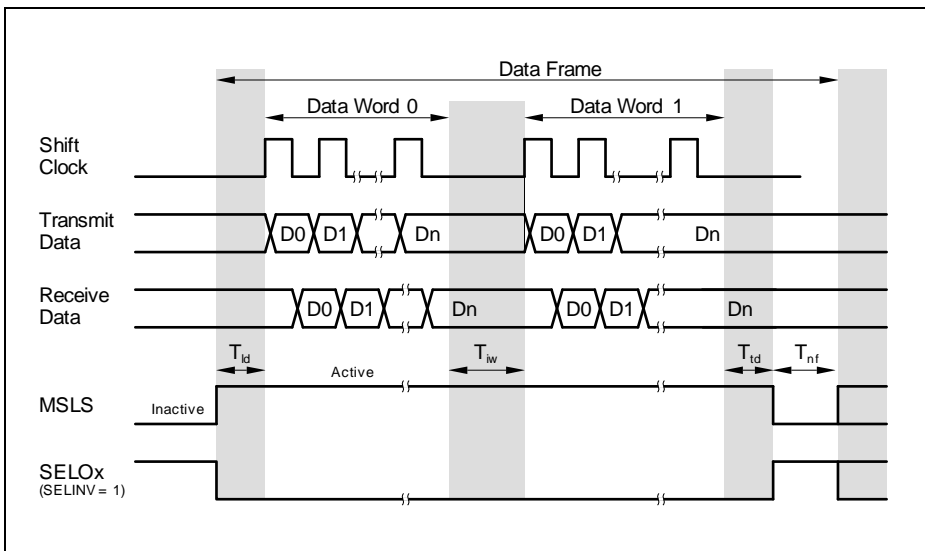
In a standard SSC application, the phase relation between the optional MCLK output signal and SCLK is not relevant and can be disabled (BRG.PPPEN = 0). In this case, the SCLK signal directly derives from the protocol input frequency  $f_{PIN}$ . In the exceptional case that a fixed phase relation between the MCLK signal and SCLK is required (e.g. when using MCLK as clock reference for external devices), the additional divider by 2 stage has to be taken into account (BRG.PPPEN = 1).

The adjustable divider factor is defined by bit field BRG.PDIV.

$$\begin{aligned}
 f_{SCLK} &= \frac{f_{PIN}}{2} \times \frac{1}{PDIV + 1} && \text{if } PPPEN = 0 \\
 f_{SCLK} &= \frac{f_{PIN}}{2 \times 2} \times \frac{1}{PDIV + 1} && \text{if } PPPEN = 1
 \end{aligned}
 \tag{15.8}$$

### 15.4.3.2 MSLS Generation

The slave select signals indicate the start and the end of a data frame and are also used by the communication master to individually select the desired slave device. A slave select output of the communication master becomes active a programmable time before a data part of the frame is started (leading delay  $T_{ld}$ ), necessary to prepare the slave device for the following communication. After the transfer of a data part of the frame, it becomes inactive again a programmable time after the end of the last bit (trailing delay  $T_{td}$ ) to respect the slave hold time requirements. If data frames are transferred back-to-back one after the other, the minimum time between the deactivation of the slave select and the next activation of a slave select is programmable (next-frame delay  $T_{nf}$ ). If a data frame consists of more than one data word, an optional delay between the data words can also be programmed (inter-word delay  $T_{iw}$ ).



**Figure 15-45 MSLS Generation in SSC Master Mode**

In SSC master mode, the slave select delays are defined as follows:

- **Leading delay  $T_{ld}$ :**  
The leading delay starts if valid data is available for transmission. The internal signal MSLS becomes active with the start of the leading delay. The first shift clock edge (rising edge) of SCLK is generated by the baud rate generator after the leading delay has elapsed.
- **Trailing delay  $T_{td}$**   
The trailing delay starts at the end of the last SCLK cycle of a data frame. The internal signal MSLS becomes inactive with the end of the trailing delay.

---

**Universal Serial Interface Channel (USIC)**

- Inter-word delay  $T_{iw}$ :  
This delay is optional and can be enabled/disabled by PCR.TIWEN. If the inter-word delay is disabled (TIWEN = 0), the last data bit of a data word is directly followed by the first data bit of the next data word of the same data frame. If enabled (TIWEN = 1), the inter-word delay starts at the end of the last SCLK cycle of a data word. The first SCLK cycle of the following data word of the same data frame is started when the inter-word delay has elapsed. During this time, no shift clock pulses are generated and signal MSLS stays active. The communication partner has time to “digest” the previous data word or to prepare for the next one.
- Next-frame delay  $T_{nf}$ :  
The next-frame delay starts at the end of the trailing delay. During this time, no shift clock pulses are generated and signal MSLS stays inactive. A frame is considered as finished after the next-frame delay has elapsed.

### 15.4.3.3 Automatic Slave Select Update

If the number of bits per SSC frame and the word length are defined by bit fields SCTR.FLE and SCTR.WLE, the transmit control information TCI can be used to update the slave select setting PCR.CTR[23:16] to control the SELO<sub>x</sub> select outputs. The automatic update mechanism is enabled by TCSR.SELMD = 1 (bits TCSR.WLEMD, FLEMD, and WAMD have to be cleared). In this case, the TCI of the first data word of a frame defines the slave select setting of the complete frame due to the automatic shadow mechanism (see [Page 15-61](#)).

### 15.4.3.4 Slave Select Delay Generation

The slave select delay generation is based on time quanta. The length of a time quantum (defined by the period of the  $f_{CTQIN}$ ) and the number of time quanta per delay can be programmed.

In standard SSC applications, the leading delay  $T_{ld}$  and the trailing delay  $T_{td}$  are mainly used to ensure stability on the input and output lines as well as to respect setup and hold times of the input stages. These two delays have the same length (in most cases shorter than a bit time) and can be programmed with the same set of bit fields.

- BRG.CTQSEL  
to define the input frequency  $f_{CTQIN}$  for the time quanta generation for  $T_{ld}$  and  $T_{td}$
- BRG.PCTQ  
to define the length of a time quantum (division of  $f_{CTQIN}$  by 1, 2, 3, or 4) for  $T_{ld}$  and  $T_{td}$
- BRG.DCTQ  
to define the number of time quanta for the delay generation for  $T_{ld}$  and  $T_{td}$

The inter-word delay  $T_{iw}$  and the next-frame delay  $T_{nf}$  are used to handle received data or to prepare data for the next word or frame. These two delays have the same length (in most cases in the bit time range) and can be programmed with a second, independent set of bit fields.

- PCR.CTQSEL1  
to define the input frequency  $f_{CTQIN}$  for the time quanta generation for  $T_{nf}$  and  $T_{iw}$
- PCR.PCTQ1  
to define the length of a time quantum (division of  $f_{CTQIN}$  by 1, 2, 3, or 4) for  $T_{nf}$  and  $T_{iw}$
- PCR.DCTQ1  
to define the number of time quanta for the delay generation for  $T_{nf}$  and  $T_{iw}$
- PCR.TIWEN  
to enable/disable the inter-word delay  $T_{iw}$

Each delay depends on the length of a time quantum and the programmed number of time quanta given by the bit fields CTQSEL/CTQSEL1, PCTQ/DCTQ and PCTQ1/DCTQ1 (the coding of CTQSEL1 is similar to CTQSEL, etc.). To provide a high flexibility in programming the delay length, the input frequencies can be selected between several possibilities (e.g. based on bit times or on the faster inputs of the protocol-related divider). The delay times are defined as follows:

$$T_{ld} = T_{td} = \frac{(PCTQ + 1) \times (DCTQ + 1)}{f_{CTQIN}} \quad (15.9)$$

$$T_{iw} = T_{nf} = \frac{(PCTQ1 + 1) \times (DCTQ1 + 1)}{f_{CTQIN}}$$



### 15.4.3.5 Protocol Interrupt Events

The following protocol-related events generated in SSC mode and can lead to a protocol interrupt. They are related to the start and the end of a data frame. After the start of a data frame a new setting could be programmed for the next data frame and after the end of a data frame the SSC connections to pins can be changed.

Please note that the bits in register PSR are not all automatically cleared by hardware and have to be cleared by software in order to monitor new incoming events.

- **MSLS Interrupt:**  
This interrupt indicates in master mode (MSLS generation enabled) that a data frame has started (activation of MSLS) and has been finished (deactivation of MSLS). Any change of the internal MSLS signal sets bit PSR.MSLSEV and additionally, a protocol interrupt can be generated if PCR.MSLSIEN = 1. The actual state of the internal MSLS signal can be read out at PSR.MSLS to take appropriate actions when this interrupt has been detected.
- **DX2T Interrupt:**  
This interrupt monitors edges of the input signal of the DX2 stage (although this signal is not used as slave select input for data transfers).  
A programmable edge detection for the DX2 input signal sets bit PSR.DX2TEV and additionally, a protocol interrupt can be generated if PCR.DX2TIEN = 1. The actual state of the selected input signal can be read out at PSR.DX2S to take appropriate actions when this interrupt has been detected.
- **Parity Error Interrupt:**  
This interrupt indicates that there is a mismatch in the received parity bit (in RBUFSR.PAR) with the calculated parity bit of the last received word of a data frame.

### 15.4.3.6 End-of-Frame Control

The information about the frame length is required for the MSLS generator of the master device. In addition to the mechanism based on the number of bits per frame (selected with  $SCTR.FLE < 63$ ), the following alternative mechanisms for end of frame handling are supported. It is recommended to set  $SCTR.FLE = 63$  (if several end of frame mechanisms are activated in parallel, the first end condition being found finishes the frame).

- **Software-based start of frame indication TCSR.SOF:**  
This mechanism can be used if software handles the TBUF data without data FIFO. If bit SOF is set, a valid content of TBUF is considered as first word of a new frame. Bit SOF has to be set before the content of TBUF is transferred to the transmit shift register, so it is recommended to write it before writing data to TBUF. A current data word transfer is finished completely and the slave select delays  $T_{td}$  and  $T_{nr}$  are applied before starting a new data frame with  $T_{td}$  and the content of TBUF. For software-handling of bit SOF, bit  $TCSR.WLEMD = 0$  has to be programmed. In this case, all  $TBUF[31:0]$  address locations show an identical behavior (TCI not taken into account for data handling).
- **Software-based end of frame indication TCSR.EOF:**  
This mechanism can be used if software handles the TBUF data without data FIFO. If bit EOF is set, a valid content of TBUF is considered as last word of a new frame. Bit EOF has to be set before the content of TBUF is transferred to the transmit shift register, so it is recommended to write it before writing data to TBUF. The data word in TBUF is sent out completely and the slave select delays  $T_{td}$  and  $T_{nr}$  are applied. A new data frame can start with  $T_{td}$  with the next valid TBUF value. For software-handling of bit EOF, bit  $TCSR.WLEMD = 0$  has to be programmed. In this case, all  $TBUF[31:0]$  address locations show an identical behavior (TCI not taken into account for data handling).
- **Software-based address related end of frame handling:**  
This mechanism can be used if software handles the TBUF data without data FIFO. If bit  $TCSR.WLEMD = 1$ , the address of the written  $TBUF[31:0]$  is used as transmit control information  $TCI[4:0]$  to update  $SCTR.WLE (= TCI[3:0])$  and  $TCSR.EOF (= TCI[4])$  for each data word. The written  $TBUF[31:0]$  address location defines the word length and the end of a frame (locations  $TBUF[31:16]$  lead to a frame end). For example, writing transmit data to  $TBUF[07]$  results in a data word of 8-bit length without finishing the frame, whereas writing transmit data to  $TBUF[31]$  leads to a data word length of 16 bits, followed by  $T_{td}$ , the deactivation of MSLS and  $T_{nr}$ . If  $TCSR.WLEMD = 1$ , bits  $TCSR.EOF$  and  $SOF$ , as well as  $SCTR.WLE$  must not be written by software after writing data to a TBUF location. Furthermore, it is recommended to clear bits  $TCSR.SELMD$ ,  $FLEMD$  and  $WAMD$ .
- **FIFO-based address related end of frame handling:**  
This mechanism can be used if a data FIFO is used to store the transmit data. The general behavior is similar to the software-based address related end of frame

---

**Universal Serial Interface Channel (USIC)**

handling, except that transmit data is not written to the locations TBUF[31:0], but to the FIFO input locations IN[31:0] instead. In this case, software must not write to any of the TBUF locations.

- **TBUF related end of frame handling:**  
If bit PCR.FEM = 0, an end of frame is assumed if the transmit buffer TBUF does not contain valid transmit data at the end of a data word transmission (TCSR.TDV = 0 or in Stop Mode). In this case, the software has to take care that TBUF does not run empty during a data frame in Run Mode. If bit PCR.FEM = 1, signal MSLS stays active while the transmit buffer is waiting for new data (TCSR.TDV = 1 again) or until Stop Mode is left.
- **Explicit end of frame by software:**  
The software can explicitly stop a frame by clearing bit PSR.MSLS by writing a 1 to the related bit position in register PSCR. This write action immediately clears bit PSR.MSLS, whereas the internal MSLS signal becomes inactive after finishing a currently running word transfer and respecting the slave select delays  $T_{id}$  and  $T_{nr}$ .

### 15.4.4 Operating the SSC in Slave Mode

In order to operate the SSC in slave mode, the following issues have to be considered:

- **Select SSC mode:**  
It is recommended to configure all parameters of the SSC that do not change during run time while  $CCR.MODE = 0000_B$ . Bit field  $SCTR.TRM = 01_B$  has to be programmed. The configuration of the input stages has to be done while  $CCR.MODE = 0000_B$  to avoid unintended edges of the input signals and the SSC mode can be enabled afterwards by  $CCR.MODE = 0001_B$ .
- **Pin connections:**  
Establish the connection of the input stage (DX0, DX3, DX4, DX5) with the selected receive data input pin (DIN[3:0]) with  $DXnCR.INSW = 1$  and configure the transmit data output pin (DOUT[3:0]). One, two or four such connections may be needed depending on the protocol. For half-duplex configurations, hardware port control can be also used to establish the required connections.  
Establish a connection of input stage DX1 with the selected shift clock input pin (signal SCLKIN) with  $DX1CR.INSW = 1$ .  
Establish a connection of input stage DX2 with the selected slave select input pin (signal SELIN) with  $DX2CR.INSW = 1$ . If no slave select input signal is used, the DX2 stage has to deliver a 1-level to the data shift unit to allow data reception and transmission. If a slave device is not selected (DX2 stage delivers a 0 to the data shift unit) and a shift clock pulse are received, the incoming data is not received and the DOUTx signal outputs the passive data level defined by  $SCTR.PDL$ .  
Note that the step to enable the alternate output port functions should only be done after the SSC mode is enabled, to avoid unintended spikes on the output.
- **Baud rate generation:**  
The baud rate generator is not needed and can be switched off by the fractional divider.
- **Data format configuration:**  
If required, the shift mode can be set up for reception and/or transmission of two or four data bits at one time by programming the register SCTR.
- **Slave select generation:**  
The slave select delay generation is not needed and can be switched off. The bits and bit fields MSLSEN, SELCTR, SELINV, CTQSEL1, PCTQ1, DCTQ1, MSLSIEN, SELO[7:0], and TIWEN in register PCR are not necessary and can be programmed to 0.

#### 15.4.4.1 Protocol Interrupts

The following protocol-related events generated in SSC mode and can lead to a protocol interrupt. They are related to the start and the end of a data frame. After the start of a data frame a new setting could be programmed for the next data frame and after the end of a data frame the SSC connections to pins can be changed.

---

**Universal Serial Interface Channel (USIC)**

Please note that the bits in register PSR are not all automatically cleared by hardware and have to be cleared by software in order to monitor new incoming events.

- **MCLS event:**  
The MCLS generation being switched off, this event is not available.
- **DX2T event:**  
The slave select input signal SELIN is handled by the DX2 stage and the edges of the selected signal can generate a protocol interrupt. This interrupt allows to indicate that a data frame has started and/or that a data frame has been completely finished. A programmable edge detection for the DX2 input signal activates DX2T, sets bit PSR.DX2TEV and additionally, a protocol interrupt can be generated if PCR.DX2TIEN = 1. The actual state of the selected input signal can be read out at PSR.DX2S to take appropriate actions when this interrupt has been detected.
- **Parity Error Interrupt:**  
This interrupt indicates that there is a mismatch in the received parity bit (in RBUFSR.PAR) with the calculated parity bit of the last received word of a data frame.

#### **15.4.4.2 End-of-Frame Control**

In slave mode, the following possibilities exist to determine the frame length. The slave device either has to refer to an external slave select signal, or to the number of received data bits.

- **Frame length known in advance by the slave device, no slave select:**  
In this case bit field SCTR.FLE can be programmed to the known value (if it does not exceed 63 bits). A currently running data word transfer is considered as finished if the programmed frame length is reached.
- **Frame length not known by the slave, no slave select:**  
In this case, the slave device's software has to decide on data word base if a frame is finished. Bit field SCTR.FLE can be either programmed to the word length SCTR.WLE, or to its maximum value to disable the slave internal frame length evaluation by counting received bits.
- **Slave device addressed via slave select signal SELIN:**  
If the slave device is addressed by a slave select signal delivered by the communication master, the frame start and end information are given by this signal. In this case, bit field SCTR.FLE should be programmed to its maximum value to disable the slave internal frame length evaluation.

**Universal Serial Interface Channel (USIC)**

**15.4.5 SSC Protocol Registers**

In SSC mode, the registers PCR and PSR handle SSC related information.

**15.4.5.1 SSC Protocol Control Registers**

In SSC mode, the PCR register bits or bit fields are defined as described in this section.

**PCR**

**Protocol Control Register [SSC Mode]**

(3C<sub>H</sub>)

Reset Value: 0000 0000<sub>H</sub>

31	30	29	28	27	26	25	24	23	22	21	20	19	18	17	16
<b>MCLK</b>		0				<b>SLPHSEL</b>	<b>TIWEN</b>	<b>SELO</b>							
rw		rw				rw	rw	rw							
15	14	13	12	11	10	9	8	7	6	5	4	3	2	1	0
<b>DX2TIEN</b>	<b>MSLSIEN</b>	<b>PARIEN</b>	<b>DCTQ1</b>				<b>PCTQ1</b>		<b>CTQSEL1</b>		<b>FEM</b>	<b>SELINV</b>	<b>SELCTR</b>	<b>MSLSEN</b>	
rw	rw	rw	rw				rw		rw		rw	rw	rw	rw	rw

Field	Bits	Type	Description
<b>MSLSEN</b>	0	rw	<p><b>MSLS Enable</b></p> <p>This bit enables/disables the generation of the master slave select signal MSLS. If the SSC is a transfer slave, the SLS information is read from a pin and the internal generation is not needed. If the SSC is a transfer master, it has to provide the MSLS signal.</p> <p>0<sub>B</sub> The MSLS generation is disabled (MSLS = 0). This is the setting for SSC slave mode.</p> <p>1<sub>B</sub> The MSLS generation is enabled. This is the setting for SSC master mode.</p>
<b>SELCTR</b>	1	rw	<p><b>Select Control</b></p> <p>This bit selects the operating mode for the SELO[7:0] outputs.</p> <p>0<sub>B</sub> The coded select mode is enabled.</p> <p>1<sub>B</sub> The direct select mode is enabled.</p>

**Universal Serial Interface Channel (USIC)**

Field	Bits	Type	Description
<b>SELINV</b>	2	rw	<p><b>Select Inversion</b></p> <p>This bit defines if the polarity of the SELO[7:0] outputs in relation to the master slave select signal MSLS.</p> <p>0<sub>B</sub> The SELO outputs have the same polarity as the MSLS signal (active high).</p> <p>1<sub>B</sub> The SELO outputs have the inverted polarity to the MSLS signal (active low).</p>
<b>FEM</b>	3	rw	<p><b>Frame End Mode</b></p> <p>This bit defines if a transmit buffer content that is not valid for transmission is considered as an end of frame condition for the slave select generation.</p> <p>0<sub>B</sub> The current data frame is considered as finished when the last bit of a data word has been sent out and the transmit buffer TBUF does not contain new data (TDV = 0).</p> <p>1<sub>B</sub> The MSLS signal is kept active also while no new data is available and no other end of frame condition is reached. In this case, the software can accept delays in delivering the data without automatic deactivation of MSLS in multi-word data frames.</p>
<b>CTQSEL1</b>	[5:4]	rw	<p><b>Input Frequency Selection</b></p> <p>This bit field defines the input frequency <math>f_{CTQIN}</math> for the generation of the slave select delays <math>T_{iw}</math> and <math>T_{nf}</math>.</p> <p>00<sub>B</sub> <math>f_{CTQIN} = f_{PDIV}</math></p> <p>01<sub>B</sub> <math>f_{CTQIN} = f_{PPP}</math></p> <p>10<sub>B</sub> <math>f_{CTQIN} = f_{SCLK}</math></p> <p>11<sub>B</sub> <math>f_{CTQIN} = f_{MCLK}</math></p>
<b>PCTQ1</b>	[7:6]	rw	<p><b>Divider Factor PCTQ1 for <math>T_{iw}</math> and <math>T_{nf}</math></b></p> <p>This bit field represents the divider factor PCTQ1 (range = 0 - 3) for the generation of the inter-word delay and the next-frame delay.</p> $T_{iw} = T_{nf} = 1/f_{CTQIN} \times (PCTQ1 + 1) \times (DCTQ1 + 1)$
<b>DCTQ1</b>	[12:8]	rw	<p><b>Divider Factor DCTQ1 for <math>T_{iw}</math> and <math>T_{nf}</math></b></p> <p>This bit field represents the divider factor DCTQ1 (range = 0 - 31) for the generation of the inter-word delay and the next-frame delay.</p> $T_{iw} = T_{nf} = 1/f_{CTQIN} \times (PCTQ1 + 1) \times (DCTQ1 + 1)$

**Universal Serial Interface Channel (USIC)**

Field	Bits	Type	Description
<b>PARIEN</b>	13	rw	<p><b>Parity Error Interrupt Enable</b></p> <p>This bit enables/disables the generation of a protocol interrupt with the detection of a parity error.</p> <p>0<sub>B</sub> A protocol interrupt is not generated with the detection of a parity error.</p> <p>1<sub>B</sub> A protocol interrupt is generated with the detection of a parity error.</p>
<b>MSLSIEN</b>	14	rw	<p><b>MSLS Interrupt Enable</b></p> <p>This bit enables/disables the generation of a protocol interrupt if the state of the MSLS signal changes (indicated by PSR.MSLSEV = 1).</p> <p>0<sub>B</sub> A protocol interrupt is not generated if a change of signal MSLS is detected.</p> <p>1<sub>B</sub> A protocol interrupt is generated if a change of signal MSLS is detected.</p>
<b>DX2TIEN</b>	15	rw	<p><b>DX2T Interrupt Enable</b></p> <p>This bit enables/disables the generation of a protocol interrupt if the DX2T signal becomes activated (indicated by PSR.DX2TEV = 1).</p> <p>0<sub>B</sub> A protocol interrupt is not generated if DX2T is activated.</p> <p>1<sub>B</sub> A protocol interrupt is generated if DX2T is activated.</p>
<b>SELO</b>	[23:16]	rw	<p><b>Select Output</b></p> <p>This bit field defines the setting of the SELO[7:0] output lines.</p> <p>0<sub>B</sub> The corresponding SELO<sub>x</sub> line cannot be activated.</p> <p>1<sub>B</sub> The corresponding SELO<sub>x</sub> line can be activated (according to the mode selected by SELCTR).</p>
<b>TIWEN</b>	24	rw	<p><b>Enable Inter-Word Delay T<sub>iw</sub></b></p> <p>This bit enables/disables the inter-word delay T<sub>iw</sub> after the transmission of a data word.</p> <p>0<sub>B</sub> No delay between data words of the same frame.</p> <p>1<sub>B</sub> The inter-word delay T<sub>iw</sub> is enabled and introduced between data words of the same frame.</p>



**Universal Serial Interface Channel (USIC)**

Field	Bits	Type	Description
<b>SLPHSEL</b>	25	rw	<p><b>Slave Mode Clock Phase Select</b></p> <p>This bit selects the clock phase for the data shifting in slave mode.</p> <p>0<sub>B</sub> Data bits are shifted out with the leading edge of the shift clock signal and latched in with the trailing edge.</p> <p>1<sub>B</sub> The first data bit is shifted out when the data shift unit receives a low to high transition from the DX2 stage. Subsequent bits are shifted out with the trailing edge of the shift clock signal. Data bits are always latched in with the leading edge.</p>
<b>MCLK</b>	31	rw	<p><b>Master Clock Enable</b></p> <p>This bit enables/disables the generation of the master clock output signal MCLK, independent from master or slave mode.</p> <p>0<sub>B</sub> The MCLK generation is disabled and output MCLK = 0.</p> <p>1<sub>B</sub> The MCLK generation is enabled.</p>
<b>0</b>	[30:26]	rw	<p><b>Reserved</b></p> <p>Returns 0 if read; should be written with 0.</p>

**Universal Serial Interface Channel (USIC)**

**15.4.5.2 SSC Protocol Status Register**

In SSC mode, the PSR register bits or bit fields are defined as described in this section. The bits and bit fields in register PSR are not cleared by hardware.

The flags in the PSR register can be cleared by writing a 1 to the corresponding bit position in register PSCR. Writing a 1 to a bit position in PSR sets the corresponding flag, but does not lead to further actions (no interrupt generation). Writing a 0 has no effect. The PSR flags should be cleared by software before enabling a new protocol.

**PSR**

**Protocol Status Register [SSC Mode] (48<sub>H</sub>)**

**Reset Value: 0000 0000<sub>H</sub>**

31	30	29	28	27	26	25	24	23	22	21	20	19	18	17	16
0															<b>BRG IF</b>
r															rwh
15	14	13	12	11	10	9	8	7	6	5	4	3	2	1	0
<b>AIF</b>	<b>RIF</b>	<b>TBIF</b>	<b>TSIF</b>	<b>DLIF</b>	<b>RSIF</b>	0					<b>PAR ERR</b>	<b>DX2 TEV</b>	<b>MSL SEV</b>	<b>DX2 S</b>	<b>MSL S</b>
rwh	rwh	rwh	rwh	rwh	rwh	r					rwh	rwh	rwh	rwh	rwh

Field	Bits	Type	Description
<b>MSLS</b>	0	rwh	<p><b>MSLS Status</b></p> <p>This bit indicates the current status of the MSLS signal. It must be cleared by software to stop a running frame.</p> <p>0<sub>B</sub> The internal signal MSLS is inactive (0). 1<sub>B</sub> The internal signal MSLS is active (1).</p>
<b>DX2S</b>	1	rwh	<p><b>DX2S Status</b></p> <p>This bit indicates the current status of the DX2S signal that can be used as slave select input SELIN.</p> <p>0<sub>B</sub> DX2S is 0. 1<sub>B</sub> DX2S is 1.</p>
<b>MSLSEV</b>	2	rwh	<p><b>MSLS Event Detected<sup>1)</sup></b></p> <p>This bit indicates that the MSLS signal has changed its state since MSLSEV has been cleared. Together with the MSLS status bit, the activation/deactivation of the MSLS signal can be monitored.</p> <p>0<sub>B</sub> The MSLS signal has not changed its state. 1<sub>B</sub> The MSLS signal has changed its state.</p>

**Universal Serial Interface Channel (USIC)**

Field	Bits	Type	Description
<b>DX2TEV</b>	3	rwh	<b>DX2T Event Detected<sup>1)</sup></b> This bit indicates that the DX2T trigger signal has been activated since DX2TEV has been cleared. 0 <sub>B</sub> The DX2T signal has not been activated. 1 <sub>B</sub> The DX2T signal has been activated.
<b>PARERR</b>	4	rwh	<b>Parity Error Event Detected<sup>1)</sup></b> This bit indicates that there is a mismatch in the received parity bit (in RBUF <sub>SR</sub> .PAR) with the calculated parity bit of the last received word of the data frame. 0 <sub>B</sub> A parity error event has not been activated. 1 <sub>B</sub> A parity error event has been activated.
<b>RSIF</b>	10	rwh	<b>Receiver Start Indication Flag</b> 0 <sub>B</sub> A receiver start event has not occurred. 1 <sub>B</sub> A receiver start event has occurred.
<b>DLIF</b>	11	rwh	<b>Data Lost Indication Flag</b> 0 <sub>B</sub> A data lost event has not occurred. 1 <sub>B</sub> A data lost event has occurred.
<b>TSIF</b>	12	rwh	<b>Transmit Shift Indication Flag</b> 0 <sub>B</sub> A transmit shift event has not occurred. 1 <sub>B</sub> A transmit shift event has occurred.
<b>TBIF</b>	13	rwh	<b>Transmit Buffer Indication Flag</b> 0 <sub>B</sub> A transmit buffer event has not occurred. 1 <sub>B</sub> A transmit buffer event has occurred.
<b>RIF</b>	14	rwh	<b>Receive Indication Flag</b> 0 <sub>B</sub> A receive event has not occurred. 1 <sub>B</sub> A receive event has occurred.
<b>AIF</b>	15	rwh	<b>Alternative Receive Indication Flag</b> 0 <sub>B</sub> An alternative receive event has not occurred. 1 <sub>B</sub> An alternative receive event has occurred.
<b>BRGIF</b>	16	rwh	<b>Baud Rate Generator Indication Flag</b> 0 <sub>B</sub> A baud rate generator event has not occurred. 1 <sub>B</sub> A baud rate generator event has occurred.
<b>0</b>	[9:5], [31:17]	r	<b>Reserved</b> Returns 0 if read; not modified in SSC mode.

1) This status bit can generate a protocol interrupt in SSC mode (see [Page 15-21](#)). The general interrupt status flags are described in the general interrupt chapter.

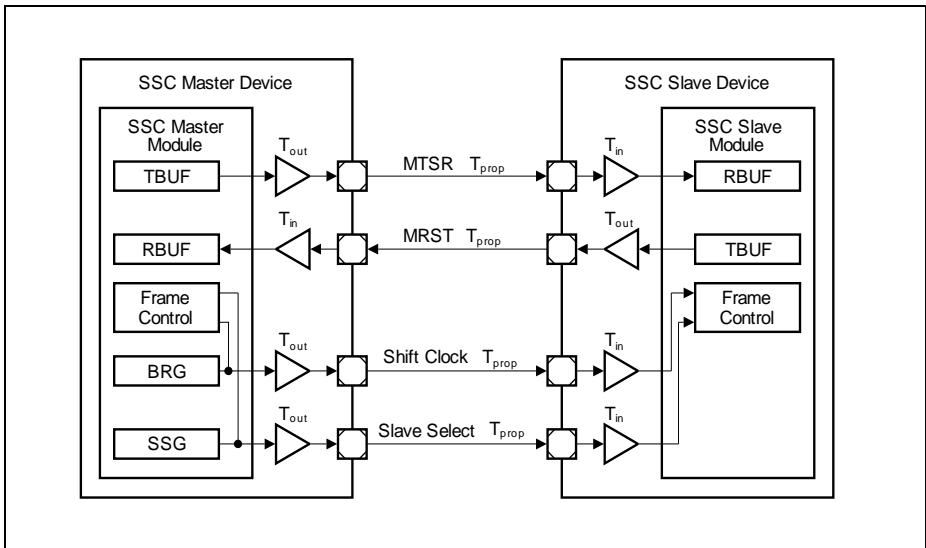
### 15.4.6 SSC Timing Considerations

The input and output signals have to respect certain timings in order to ensure correct data reception and transmission. In addition to module internal timings (due to input filters, reaction times on events, etc.), also the timings from the input pin via the input stage ( $T_{in}$ ) to the module and from the module via the output driver stage to the pin ( $T_{out}$ ), as well as the signal propagation on the wires ( $T_{prop}$ ) have to be taken into account.

Please note that there might be additional delays in the DXn input stages, because the digital filter and the synchronization stages lead to systematic delays, that have to be considered if these functions are used.

#### 15.4.6.1 Closed-loop Delay

A system-inherent limiting factor for the baud rate of an SSC connection is the closed-loop delay. In a typical application setup, a communication master device is connected to a slave device in full-duplex mode with independent lines for transmit and receive data. In a general case, all transmitters refer to one shift clock edge for transmission and all receivers refer to the other shift clock edge for reception. The master device's SSC module sends out the transmit data, the shift clock and optionally the slave select signal. Therefore, the baud rate generation (BRG) and slave select generation (SSG) are part of the master device. The frame control is similar for SSC modules in master and slave mode, the main difference is the fact which module generates the shift clock and optionally, the slave select signals.



**Figure 15-46 SSC Closed-loop Delay**

---

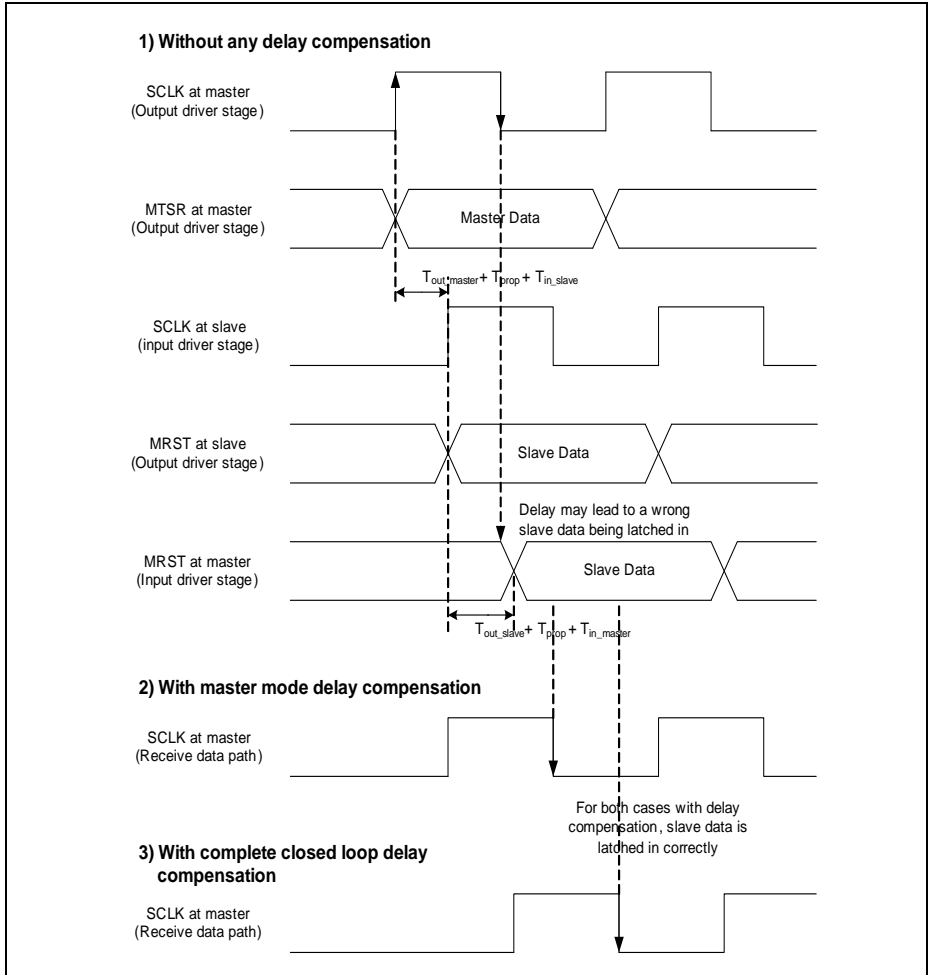
**Universal Serial Interface Channel (USIC)**

The signal path between the SSC modules of the master and the slave device includes the master's output driver, the wiring to the slave device and the slave device's input stage. With the received shift clock edges, the slave device receives the master's transmit data and transmits its own data back to the master device, passing by a similar signal path in the other direction. The master module receives the slave's transmit data related to its internal shift clock edges. In order to ensure correct data reception in the master device, the slave's transmit data has to be stable (respecting setup and hold times) as master receive data with the next shift clock edge of the master (generally 1/2 shift clock period). To avoid data corruption, the accumulated delays of the input and output stages, the signal propagation on the wiring and the reaction times of the transmitter/receiver have to be carefully considered, especially at high baud rates.

In the given example, the time between the generation of the shift clock signal and the evaluation of the receive data by the master SSC module is given by the sum of  $T_{\text{out\_master}} + 2 \times T_{\text{prop}} + T_{\text{in\_slave}} + T_{\text{out\_slave}} + T_{\text{in\_master}}$  + module reaction times + input setup times. The input path is characterized by an input delay depending mainly on the input stage characteristics of the pads. The output path delay is determined by the output driver delay and its slew rate, the external load and current capability of the driver. The device specific values for the input/output driver are given in the Data Sheet.

**Universal Serial Interface Channel (USIC)**

**Figure 15-47** describes graphically the closed-loop delay and the effect of two delay compensation options discussed in [Section 15.4.6.2](#) and [Section 15.4.6.3](#).

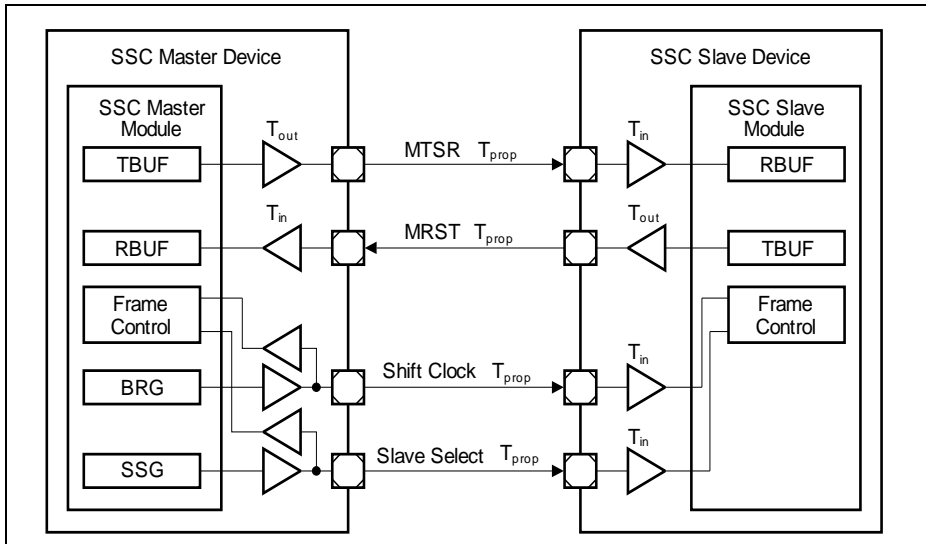


**Figure 15-47 SSC Closed-loop Delay Timing Waveform**

**Universal Serial Interface Channel (USIC)**

**15.4.6.2 Delay Compensation in Master Mode**

A higher baud rate can be reached by delay compensation in master mode. This compensation is possible if (at least) the shift clock pin is bidirectional.



**Figure 15-48 SSC Master Mode with Delay Compensation**

If the receive shift clock signal in master mode is directly taken from the input function in parallel to the output signal, the output delay of the master device's shift clock output is compensated and only the difference between the input delays of the master and the slave devices have to be taken into account instead of the complete master's output delay and the slave's input delay of the shift clock path. The delay compensation is enabled with  $DX1CR.DCEN = 1$  while  $DX1CR.INSW = 0$  (transmit shift clock is taken from the baud-rate generator).

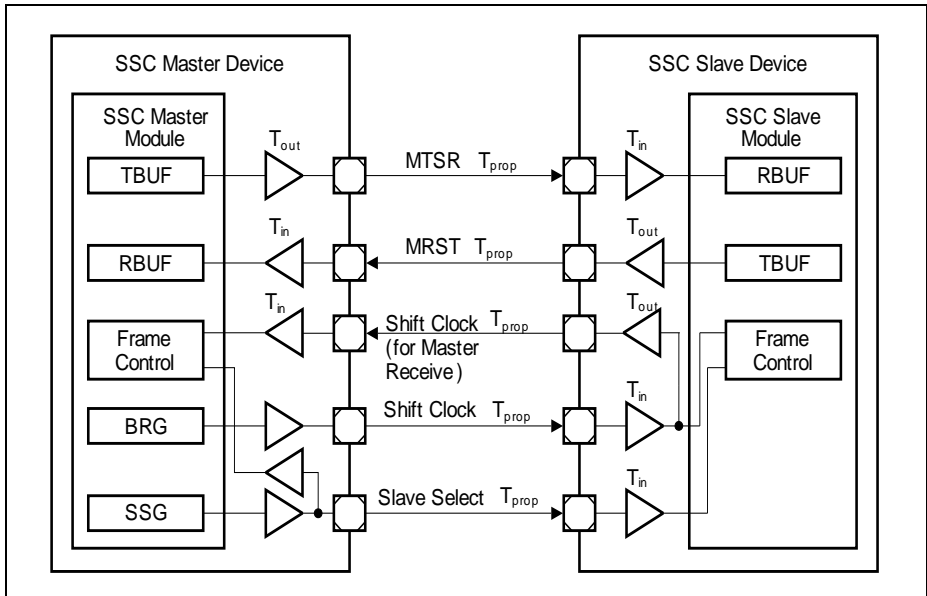
In the given example, the time between the evaluation of the shift clock signal and the receive data by the master SSC module is reduced by  $T_{in\_master} + T_{out\_master}$ .

Although being a master mode, the shift clock input and optionally the slave select signal are not directly connected internally to the data shift unit, but are taken as external signals from input pins. The delay compensation does not lead to additional pins for the SSC communication if the shift clock output pin (slave select output pin, respectively) is/are bidirectional. In this case, the input signal is decoupled from other internal signals, because it is related to the signal level at the pin itself.

**Universal Serial Interface Channel (USIC)**

**15.4.6.3 Complete Closed-loop Delay Compensation**

Alternatively, the complete closed-loop delay can be compensated by using one additional pin on both the SSC master and slave devices for the SSC communication.



**Figure 15-49 SSC Complete Closed-loop Delay Compensation**

The principle behind this delay compensation method is to have the slave feedback the shift clock back to the master, which uses it as the receive shift clock. By going through a complete closed-loop signal path, the receive shift clock is thus fully compensated.

The slave has to setup the SCLKOUT pin function to output the shift clock by setting the bit BRG.SCLKOSEL to 1, while the master has to setup the DX1 pin function to receive the shift clock from the slave and enable the delay compensation with DX1CR.DCEN = 1 and DX1CR.INSW = 0.



## 15.5 Inter-IC Bus Protocol (IIC)

The IIC protocol of the USIC refers to the IIC bus specification [7]. Contrary to that specification, the USIC device assumes rise/fall times of the bus signals of max. 300 ns in all modes. Please refer to the pad characteristics in the AC/DC chapter for the driver capability. CBUS mode and HS mode are not supported.

The IIC mode is selected by  $CCR.MODE = 0100_B$  with  $CCFG.IIC = 1$  (IIC mode available).

### 15.5.1 Introduction

USIC IIC Features:

- Two-wire interface, with one line for shift clock transfer and synchronization (shift clock SCL), the other one for the data transfer (shift data SDA)
- Communication in standard mode (100 kBit/s) or in fast mode (up to 400 kBit/s)
- Support of 7-bit addressing, as well as 10-bit addressing
- Master mode operation, where the IIC controls the bus transactions and provides the clock signal.
- Slave mode operation, where an external master controls the bus transactions and provides the clock signal.
- Multi-master mode operation, where several masters can be connected to the bus and bus arbitration can take place, i.e. the IIC module can be master or slave. The master/slave operation of an IIC bus participant can change from frame to frame.
- Efficient frame handling (low software effort)
- Powerful interrupt handling due to multitude of indication flags
- Compensation support for input delays

#### 15.5.1.1 Signal Description

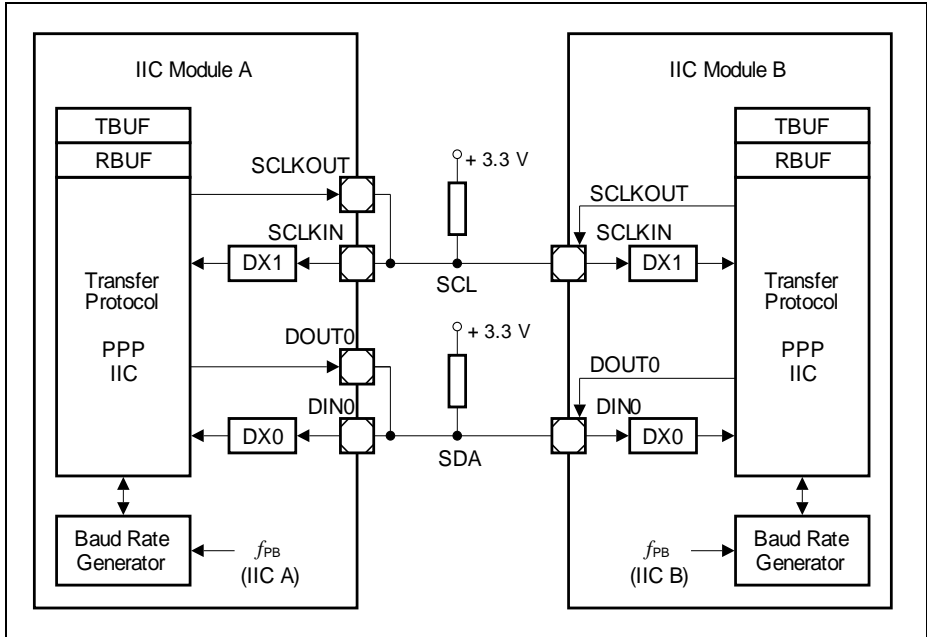
An IIC connection is characterized by two wires (SDA and SCL). The output drivers for these signals must have open-drain characteristics to allow the wired-AND connection of all SDA lines together and all SCL lines together to form the IIC bus system. Due to this structure, a high level driven by an output stage does not necessarily lead immediately to a high level at the corresponding input. Therefore, each SDA or SCL connection has to be input and output at the same time, because the input function always monitors the level of the signal, also while sending.

- Shift data SDA: input handled by DX0 stage, output signal DOUT0
- Shift clock SCL: input handled by DX1 stage, output signal SCLKOUT

**Figure 15-29** shows a connection of two IIC bus participants (modules IIC A and IIC B) using the USIC. In this example, the pin assignment of module IIC A shows separate pins for the input and output signals for SDA and SCL. This assignment can be used if the application does not provide pins having DOUT0 and a DX0 stage input for the same pin

**Universal Serial Interface Channel (USIC)**

(similar for SCLKOUT and DX1). The pin assignment of module IIC B shows the connection of DOUT0 and a DX0 input at the same pin, also for SCLKOUT and a DX1 input.



**Figure 15-50 IIC Signal Connections**

**15.5.1.2 Symbols**

A symbol is a sequence of edges on the lines SDA and SCL. Symbols contain 10 or 25 time quanta  $t_q$ , depending on the selected baud rate. The baud rate generator determines the length of the time quanta  $t_q$ , the sequence of edges in a symbol is handled by the IIC protocol pre-processor, and the sequence of symbols can be programmed by the user according to the application needs.

The following symbols are defined:

- Bus idle:  
SDA and SCL are high. No data transfer takes place currently.
- Data bit symbol:  
SDA stable during the high phase of SCL. SDA then represents the transferred bit value. There is one clock pulse on SCL for each transferred bit of data. During data transfers SDA may only change while SCL is low.

**Universal Serial Interface Channel (USIC)**

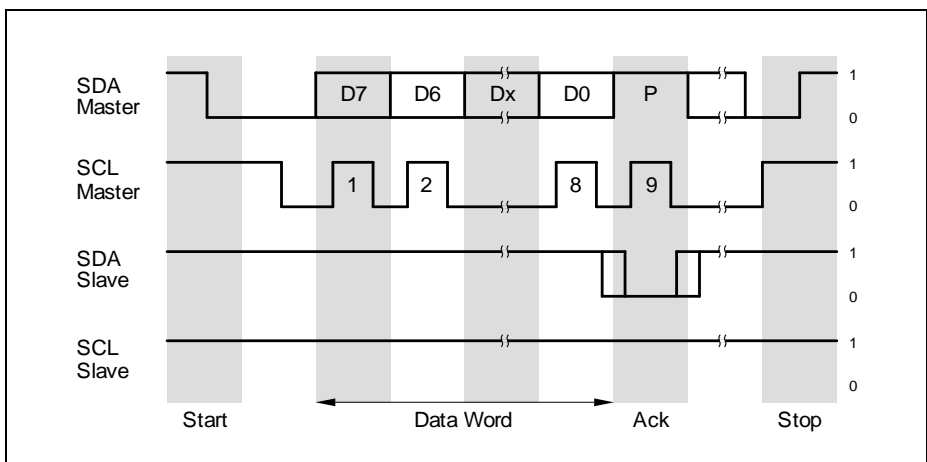
- **Start symbol:**  
Signal SDA being high followed by a falling edge of SDA while SCL is high indicates a start condition. This start condition initiates a data transfer over the IIC bus after the bus has been idle.
- **Repeated start symbol:**  
This start condition initiates a data transfer over the bus after a data symbol when the bus has not been idle. Therefore, SDA is set high and SCL low, followed by a start symbol.
- **Stop symbol:**  
A rising edge on SDA while SCL is high indicates a stop condition. This stop condition terminates a data transfer to release the bus to idle state. Between a start condition and a stop condition an arbitrary number of bytes may be transferred.

**15.5.1.3 Frame Format**

Data is transferred by the 2-line IIC bus (SDA, SCL) using a protocol that ensures reliable and efficient transfers. The sender of a (data) byte receives and checks the value of the following acknowledge field. The IIC being a wired-AND bus system, a 0 of at least one device leads to a 0 on the bus, which is received by all devices.

A data word consists of 8 data bit symbols for the data value, followed by another data bit symbol for the acknowledge bit. The data word can be interpreted as address information (after a start symbol) or as transferred data (after the address).

In order to be able to receive an acknowledge signal, the sender of the data bits has to release the SDA line by sending a 1 as acknowledge value. Depending on the internal state of the receiver, the acknowledge bit is either sent active or passive.



**Figure 15-51 IIC Frame Example (simplified)**

## 15.5.2 Operating the IIC

In order to operate the IIC protocol, the following issues have to be considered:

- **Select IIC mode:**  
It is recommended to configure all parameters of the IIC that do not change during run time while  $CCR.MODE = 0000_B$ . Bit field  $SCTR.TRM = 11_B$  should be programmed. The configuration of the input stages has to be done while  $CCR.MODE = 0000_B$  to avoid unintended edges of the input signals and the IIC mode can be enabled by  $CCR.MODE = 0100_B$  afterwards.
- **Pin connections:**  
Establish a connection of input stage DX0 (with  $DX0CR.DPOL = 0$ ) to the selected shift data pin SDA (signal DIN0) with  $DX0CR.INSW = 0$  and configure the transmit data output signal DOUT0 (with  $SCTR.DOCFG = 00_B$ ) to the same pin. If available, this can be the same pin for input and output, or connect the selected input pin and the output pin to form the SDA line.  
The same mechanism applies for the shift clock line SCL. Here, signal SCLKOUT (with  $BRG.SCLKCFG = 00_B$ ) and an input of the DX1 stage have to be connected (with  $DX1CR.DPOL = 0$ ).  
The input stage DX2 is not used for the IIC protocol.  
If the digital input filters are enabled in the DX0/1 stages, their delays have to be taken into account for correct calculation of the signal timings.  
The pins used for SDA and SCL have to be set to open-drain mode to support the wired-AND structure of the IIC bus lines.  
Note that the step to enable the alternate output port functions should only be done after the IIC mode is enabled, to avoid unintended spikes on the output.
- **Bit timing configuration:**  
In standard mode (100 kBit/s) a minimum module frequency of 2 MHz is necessary, whereas in fast mode (400 kBit/s) a minimum of 10 MHz is required. Additionally, if the digital filter stage should be used to eliminate spikes up to 50 ns, a filter frequency of 20 MHz is necessary.  
There could be an uncertainty in the SCL high phase timing of maximum  $1/f_{PPP}$  if another IIC participant lengthens the SCL low phase on the bus.  
More details are given in [Section 15.5.3](#).
- **Data format configuration:**  
The data format has to be configured for 8 data bits ( $SCTR.WLE = 7$ ), unlimited data flow ( $SCTR.FLE = 3F_H$ ), and MSB shifted first ( $SCTR.SDIR = 1$ ). The parity generation has to be disabled ( $CCR.PM = 00_B$ ).
- **General hints:**  
The IIC slave module becomes active (for reception or transmission) if it is selected by the address sent by the master. In the case that the slave sends data to the master, it uses the transmit path. So a master must not request to read data from the slave address defined for its own channel in order to avoid collisions.  
The built-in error detection mechanisms are only activated while the IIC module is

---

**Universal Serial Interface Channel (USIC)**

taking part in IIC bus traffic.

If the slave can not deal with too high frequencies, it can lengthen the low phase of the SCL signal.

For data transfers according to the IIC specification, the shift data line SDA shall only change while SCL = 0 (defined by IIC bus specification).

### 15.5.2.1 Transmission Chain

The IIC bus protocol requiring a kind of in-bit-response during the arbitration phase and while a slave is transmitting, the resulting loop delay of the transmission chain can limit the reachable maximal baud rate, strongly depending on the bus characteristics (bus load, module frequency, etc.).

**Figure 15-50** shows the general signal path and the delays in the case of a slave transmission. The shift clock SCL is generated by the master device, output on the wire, then it passes through the input stage and the input filter. Now, the edges can be detected and the SDA data signal can be generated accordingly. The SDA signal passes through the output stage and the wire to the master receiver part. There, it passes through the input stage and the input filter before it is sampled.

This complete loop has to be finished (including all settling times to obtain stable signal levels) before the SCL signal changes again. The delays in this path have to be taken into account for the calculation of the baud rate as a function of  $f_{PB}$  and  $f_{PPP}$ .

### 15.5.2.2 Byte Stretching

If a device is selected as transceiver and should transmit a data byte but the transmit buffer TBUF does not contain valid data to be transmitted, the device ties down SCL = 0 at the end of the previous acknowledge bit. The waiting period is finished if new valid data has been detected in TBUF.

### 15.5.2.3 Master Arbitration

During the address and data transmission, the master transmitter checks at the rising edge of SCL for each data bit if the value it is sending is equal to the value read on the SDA line. If yes, the next data bit values can be 0. If this is not the case (transmitted value = 1, value read = 0), the master has lost the transmit arbitration. This is indicated by status flag PSR.ARL and can generate a protocol interrupt if enabled by PCR.ARLIEN.

When the transmit arbitration has been lost, the software has to initialize the complete frame again, starting with the first address byte together with the start condition for a new master transmit attempt. Arbitration also takes place for the ACK bit.

### 15.5.2.4 Non-Acknowledge and Error Conditions

In case of a non-acknowledge or an error, the TCSR.TDV flag remains set, but no further transmission will take place. User software must invalidate the transmit buffer and disable transmissions (by writing  $FMRL.MTDV = 10_B$ ), before configuring the transmission (by writing TBUF) again with appropriate values to react on the previous event. In the case the FIFO data buffer is used, additionally the FIFO buffer needs to be flushed and filled again.

### 15.5.2.5 Mode Control Behavior

In multi-master mode, only run mode 0 and stop mode 0 are supported, the other modes must not be programmed.

- Run Mode 0:  
Behavior as programmed. If  $TCSR.TDV = 0$  (no new valid TBUF entry found) when a new TBUF entry needs to be processed, the IIC module waits for TDV becoming set to continue operation.
- Run Mode 1:  
Behavior as programmed. If in master mode,  $TCSR.TDV = 0$  (no new valid TBUF entry found) when a new TBUF entry needs to be processed, the IIC module sends a stop condition to finish the frame. In slave mode, no difference to run mode 0.
- Stop Mode 0:  
Bit TCSR.TDV is internally considered as 0 (the bit itself is not modified by the stop mode). A currently running word is finished normally, but no new word is started in case of master mode (wait for TDV active).  
Bit TDV being considered as 0 for master and slave, the slave will force a wait state on the bus if read by an external master, too.  
Additionally, it is not possible to force the generation of a STOP condition out of the wait state. The reason is, that a master read transfer must be finished with a not-acknowledged followed by a STOP condition to allow the slave to release his SDA line. Otherwise the slave may force the SDA line to 0 (first data bit of next byte) making it impossible to generate the STOP condition (rising edge on SDA).  
To continue operation, the mode must be switched to run mode 0
- Stop Mode 1:  
Same as stop mode 0, but additionally, a master sends a STOP condition to finish the frame.  
If stop mode 1 is requested for a master device after the first byte of a 10 bit address, a stop condition will be sent out. In this case, a slave device will issue an error interrupt.

### 15.5.2.6 Data Transfer Interrupt Handling

The data transfer interrupts indicate events related to IIC frame handling. As the data input and output pins are the same in IIC protocol, a IIC transmitter also receives the

---

**Universal Serial Interface Channel (USIC)**

output data at its input pin. However, no receive related interrupts will be generated in this case.

- **Transmit buffer event:**  
The transmit buffer event indication flag PSR.TBIF is set when the content of the transmit buffer TBUF has been loaded to the transmit shift register, indicating that the action requested by the TBUF entry has started.  
With this event, bit TCSR.TDV is cleared. This interrupt can be used to write the next TBUF entry while the last one is in progress (handled by the transmitter part).
- **Receive event:**  
This receive event indication flag PSR.RIF indicates that a new data byte has been written to the receive buffer RBUF0/1 (except for the first data byte of a new frame, that is indicated by an alternative receive interrupt). The flag becomes set when the data byte is received (after the falling edge of SCL). This interrupt can be used to read out the received data while a new data byte can be in progress (handled by the receiver part).
- **Alternate receive event:**  
The alternative receive event indication flag AIF is based on bit RBUFSR[9] (same as RBUF[9]), indicating that the received data word has been the first data word of a new data frame.
- **Transmit shift event:**  
The transmit shift event indication flag TSIF is set after the start of the last data bit of a data byte.
- **Receive start event:**  
The receive start event indication flag RSIF is set after the sample point of the first data bit of a data byte.

*Note: The transmit shift and receive start events can be ignored if the application does not require them during the IIC data transfer.*

### 15.5.2.7 IIC Protocol Interrupt Events

The following protocol-related events are generated in IIC mode and can lead to a protocol interrupt.

Please note that the bits in register PSR are not all automatically cleared by hardware and have to be cleared by software in order to monitor new incoming events.

- start condition received at a correct position in a frame (PSR.SCR)
- repeated start condition received at a correct position in a frame (PSR.RSCR)
- stop condition transferred at a correct position in a frame (PSR.PCR)
- master arbitration lost (PSR.ARL)
- slave read requested (PSR.SRR)
- acknowledge received (PSR.ACK)
- non-acknowledge received (PSR.NACK)
- start condition not at the expected position in a frame (PSR.ERR)

## Universal Serial Interface Channel (USIC)

- stop condition not at the expected position in a frame (PSR.ERR)
- as slave, 10-bit address interrupted by a stop condition after the first address byte (PSR.ERR)
- TDF slave code in master mode (PSR.WTDF)
- TDF master code in slave mode (PSR.WTDF)
- Reserved TDF code found (PSR.WDTF)
- Start condition code during a running frame in master mode (PSR.WTDF)
- Data byte transmission code after transfer direction has been changed to reception (master read) in master mode (PSR.WTDF)

If a wrong TDF code is found in TBUF, the error event is active until the TDF value is either corrected or invalidated. If the related interrupt is enabled, the interrupt handler should check PSR.WDTF first and correct or invalidate TBUF, before dealing with the other possible interrupt events.

### 15.5.2.8 Baud Rate Generator Interrupt Handling

The baud rate generator interrupt indicate that the capture mode timer has reached its maximum value. With this event, the bit PSR.BRGIF is set.

### 15.5.2.9 Receiver Address Acknowledge

After a (repeated) start condition, the master sends a slave address to identify the target device of the communication. The start address can comprise one or two address bytes (for 7 bit or for 10 bit addressing schemes). After an address byte, a slave sensitive to the transmitted address has to acknowledge the reception.

Therefore, the slave's address can be programmed in the device, where it is compared to the received address. In case of a match, the slave answers with an acknowledge (SDA = 0). Slaves that are not targeted answer with a non-acknowledge (SDA = 1).

In addition to the match of the programmed address, another address byte value has to be answered with an acknowledge if the slave is capable to handle the corresponding requests. The address byte 00<sub>H</sub> indicates a general call address, that can be acknowledged. The value 01<sub>H</sub> stands for a start byte generation, that is not acknowledged

In order to allow selective acknowledges for the different values of the address byte(s), the following control mechanism is implemented:

- The address byte 00<sub>H</sub> is acknowledged if bit PCR.ACK00 is set.
- The address byte 01<sub>H</sub> is not acknowledged.
- The first 7 bits of a received first address byte are compared to the programmed slave address (PCR.SLAD[15:9]). If these bits match, the slave sends an acknowledge. In addition to this, if the slave address is programmed to 1111 0XX<sub>B</sub>, the slave device waits for a second address byte and compares it also to PCR.SLAD[7:0] and sends an acknowledge accordingly to cover the 10 bit addressing mode. The user has to



---

**Universal Serial Interface Channel (USIC)**

take care about reserved addresses (refer to IIC specification for more detailed description). Only the address 1111 0XX<sub>B</sub> is supported.

Under each of these conditions, bit PSR.SLSEL will be set when the addressing delivered a match. This bit is cleared automatically by a (repeated) start condition.

### 15.5.2.10 Receiver Handling

A selected slave receiver always acknowledges a received data byte. If the receive buffers RBUF0/1 are already full and can not accept more data, the respective register is overwritten (PSR.DLI becomes set in this case and a protocol interrupt can be generated).

An address reception also uses the registers RBUF0/1 to store the address before checking if the device is selected. The received addresses do not set RDV0/1, so the addresses are not handled like received data.

### 15.5.2.11 Receiver Status Information

In addition to the received data byte, some IIC protocol related information is stored in the 16-bit data word of the receive buffer. The received data byte is available at the bit positions RBUF[7:0], whereas the additional information is monitored at the bit positions RBUF[12:8]. This structure allows to identify the meaning of each received data byte without reading additional registers, also when using a FIFO data buffer.

- RBUF[8]:  
Value of the received acknowledge bit. This information is also available in RBUFSR[8] as protocol argument.
- RBUF[9]:  
A 1 at this bit position indicates that after a (repeated) start condition followed by the address reception the first data byte of a new frame has been received. A 0 at this bit position indicates further data bytes. This information is also available in RBUFSR[9], allowing different interrupt routines for the address and data handling.
- RBUF[10]:  
A 0 at this bit position indicates that the data byte has been received when the device has been in slave mode, whereas a 1 indicates a reception in master mode.
- RBUF[11]:  
A 1 at this bit position indicates an incomplete/erroneous data byte in the receive buffer caused by a wrong position of a START or STOP condition in the frame. The bit is not identical to the frame error status bit in PSR, because the bit in the PSR has to be cleared by software ("sticky" bit), whereas RBUF[11] is evaluated data byte by data byte. If RBUF[11] = 0, the received data byte has been correct, independent of former errors.
- RBUF[12]:  
A 0 at this bit position indicates that the programmed address has been received. A 1 indicates a general call address.

### 15.5.3 Symbol Timing

The symbol timing of the IIC is determined by the master stimulating the shift clock line SCL. It is different for standard and fast IIC mode.

- 100 kBaud standard mode (PCR.STIM = 0):  
The symbol timing is based on 10 time quanta  $t_q$  per symbol. A minimum module clock frequency  $f_{PB} = 2$  MHz is required.
- 400 kBaud standard mode (PCR.STIM = 1):  
The symbol timing is based on 25 time quanta  $t_q$  per symbol. A minimum module clock frequency  $f_{PB} = 10$  MHz is required.

The baud rate setting should only be changed while the transmitter and the receiver are idle or CCR.MODE = 0. The bits in register BRG define the length of a time quantum  $t_q$  that is given by one period of  $f_{PCTQ}$ .

- BRG.CTQSEL  
to define the input frequency  $f_{CTQIN}$  for the time quanta generation
- BRG.PCTQ  
to define the length of a time quantum (division of  $f_{CTQIN}$  by 1, 2, 3, or 4)
- BRG.DCTQ  
to define the number of time quanta per symbol (number of  $t_q = DCTQ + 1$ )

The standard setting is given by CTQSEL = 00<sub>B</sub> ( $f_{CTQIN} = f_{PDIV}$ ) and PPPEN = 0 ( $f_{PPP} = f_{IN}$ ). Under these conditions, the frequency  $f_{PCTQ}$  is given by:

$$f_{PCTQ} = f_{PIN} \times \frac{1}{PDIV + 1} \times \frac{1}{PCTQ + 1} \quad (15.10)$$

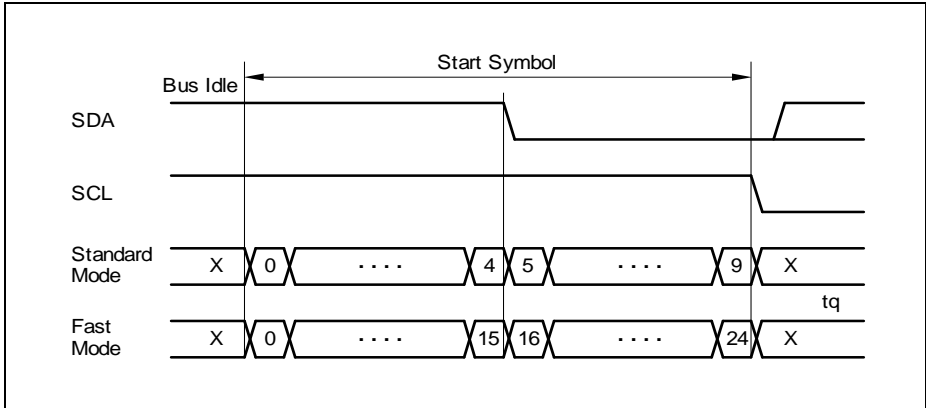
To respect the specified SDA hold time of 300 ns after a falling edge of signal SCL, a hold delay  $t_{HDEL}$  has been introduced. It also prevents an erroneous detection of a start or a stop condition. The length of this delay can be programmed by bit field PCR.HDEL. Taking into account the input sampling and output update, bit field HDEL can be programmed according to:

$$\begin{aligned} HDEL &\geq 300 \text{ ns} \times f_{PPP} - \left( 3 \times \frac{f_{PPP}}{f_{PB}} \right) + 1 && \text{with digital filter and } HDEL_{\min} = 2 \\ & && (15.11) \\ HDEL &\geq 300 \text{ ns} \times f_{PPP} - \left( 3 \times \frac{f_{PPP}}{f_{PB}} \right) + 2 && \text{without digital filter and } HDEL_{\min} = 1 \end{aligned}$$

If the digital input filter is used, HDEL compensates the filter delay of 2 filter periods ( $f_{PPP}$  should be used) in case of a spike on the input signal. This ensures that a data bit on the SDA line changing just before the rising edge or behind the falling edge of SCL will not be treated as a start or stop condition.

### 15.5.3.1 Start Symbol

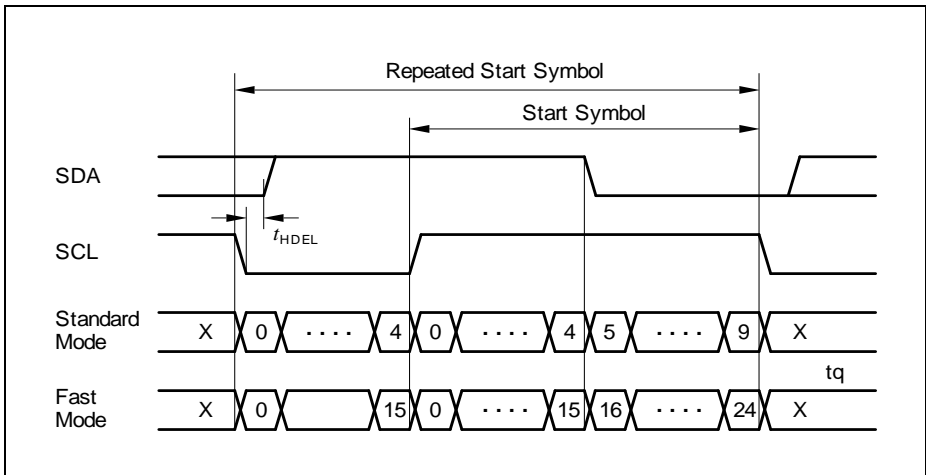
Figure 15-52 shows the general start symbol timing.



**Figure 15-52 Start Symbol Timing**

### 15.5.3.2 Repeated Start Symbol

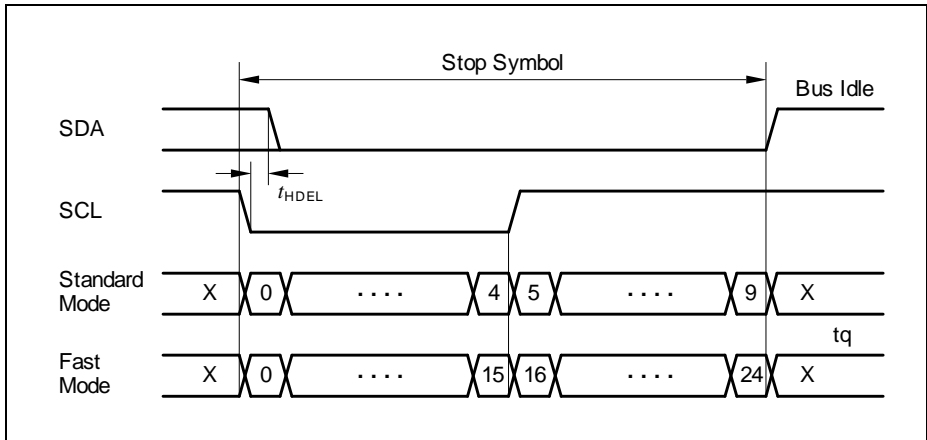
During the first part of a repeated start symbol, an SCL low value is driven for the specified number of time quanta. Then a high value is output. After the detection of a rising edge at the SCL input, a normal start symbol is generated, as shown in Figure 15-53.



**Figure 15-53 Repeated Start Symbol Timing**

### 15.5.3.3 Stop Symbol

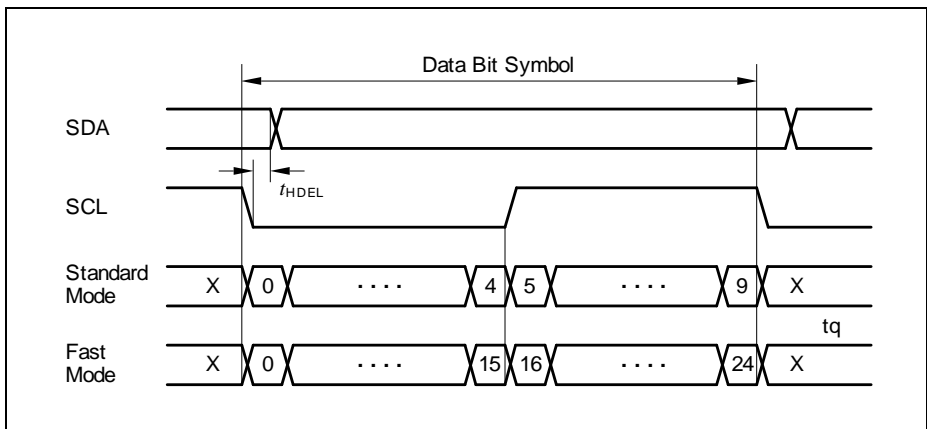
Figure 15-54 shows the stop symbol timing.



**Figure 15-54 Stop Symbol Timing**

### 15.5.3.4 Data Bit Symbol

Figure 15-55 shows the general data bit symbol timing.



**Figure 15-55 Data Bit Symbol**

Output SDA changes after the time  $t_{HDEL}$  defined by PCR.HDEL has elapsed if a falling edge is detected at the SCL input to respect the SDA hold time. The value of PCR.HDEL allows compensation of the delay of the SCL input path (sampling, filtering).

**Universal Serial Interface Channel (USIC)**

In the case of an acknowledge transmission, the USIC IIC waits for the receiver indicating that a complete byte has been received. This adds an additional delay of 3 periods of  $f_{PB}$  to the path. The minimum module input frequency has to be selected properly to ensure the SDA setup time to SCL rising edge.

**15.5.4 Data Flow Handling**

The handling of the data flow and the sequence of the symbols in an IIC frame is controlled by the IIC transmitter part of the USIC communication channel. The IIC bus protocol is byte-oriented, whereas a USIC data buffer word can contain up to 16 data bits. In addition to the data byte to be transmitted (located at TBUF[7:0]), bit field TDF (transmit data format) to control the IIC sequence is located at the bit positions TBUF[10:8]. The TDF code defines for each data byte how it should be transmitted (IIC master or IIC slave), and controls the transmission of (repeated) start and stop symbols. This structure allows the definition of a complete IIC frame for an IIC master device only by writing to TBUFx or by using a FIFO data buffer mechanism, because no other control registers have to be accessed. Alternatively, polling of the ACK and NACK bits in PSR register can be performed, and the next data byte is transmitted only after an ACK is received.

If a wrong or unexpected TDF code is encountered (e.g. due to a software error during setup of the transmit buffer), a stop condition will be sent out by the master. This leads to an abort of the currently running frame. A slave module waits for a valid TDF code and sets SCL = 0. The software then has to invalidate the unexpected TDF code and write a valid one.

Please note that during an arbitration phase in multi-master bus systems an unpredictable bus behavior may occur due to an unexpected stop condition.

**15.5.4.1 Transmit Data Formats**

The following transmit data formats are available in master mode:

**Table 15-12 Master Transmit Data Formats**

<b>TDF Code</b>	<b>Description</b>
000 <sub>B</sub>	<b>Send data byte as master</b> This format is used to transmit a data byte from the master to a slave. The transmitter sends its data byte (TBUF[7:0]), receives and checks the acknowledge bit sent by the slave.
010 <sub>B</sub>	<b>Receive data byte and send acknowledge</b> This format is used by the master to read a data byte from a slave. The master acknowledges the transfer with a 0-level to continue the transfer. The content of TBUF[7:0] is ignored.

**Universal Serial Interface Channel (USIC)**

**Table 15-12 Master Transmit Data Formats (cont'd)**

<b>TDF Code</b>	<b>Description</b>
011 <sub>B</sub>	<b>Receive data byte and send not-acknowledge</b> This format is used by the master to read a data byte from a slave. The master does not acknowledge the transfer with a 1-level to finish the transfer. The content of TBUF[7:0] is ignored.
100 <sub>B</sub>	<b>Send start condition</b> If TBUF contains this entry while the bus is idle, a start condition will be generated. The content of TBUF[7:0] is taken as first address byte for the transmission (bits TBUF[7:1] are the address, the LSB is the read/write control).
101 <sub>B</sub>	<b>Send repeated start condition</b> If TBUF contains this entry and SCL = 0 and a byte transfer is not in progress, a repeated start condition will be sent out if the device is the current master. The current master is defined as the device that has set the start condition (and also won the master arbitration) for the current message. The content of TBUF[7:0] is taken as first address byte for the transmission (bits TBUF[7:1] are the address, the LSB is the read/write control).
110 <sub>B</sub>	<b>Send stop condition</b> If the current master has finished its last byte transfer (including acknowledge), it sends a stop condition if this format is in TBUF. The content of TBUF[7:0] is ignored.
111 <sub>B</sub>	<b>Reserved</b> This code must not be programmed. No additional action except releasing the TBUF entry and setting the error bit in PSR (that can lead to a protocol interrupt).

The following transmit data format is available in slave mode (the symbols in a frame are controlled by the master and the slave only has to send data if it has been “asked” by the master):

**Table 15-13 Slave Transmit Data Format**

<b>TDF Code</b>	<b>Description</b>
001 <sub>B</sub>	<b>Send data byte as slave</b> This format is used to transmit a data byte from a slave to the master. The transmitter sends its data byte (TBUF[7:0]) plus the acknowledge bit as a 1.

**Universal Serial Interface Channel (USIC)**

**15.5.4.2 Valid Master Transmit Data Formats**

Due to the IIC frame format definitions, only some specific sequences of TDF codes are possible and valid. If the USIC IIC module detects a wrong TDF code in a running frame, the transfer is aborted and flag PCR.WTDF is set. Additionally, an interrupt can be generated if enabled by the user. In case of a wrong TDF code, the frame will be aborted immediately with a STOP condition if the USIC IIC master still owns the SDA line. But if the accessed slave owns the SDA line (read transfer), the master must perform a dummy read with a non-acknowledge so that the slave releases the SDA line before a STOP condition can be sent. The received data byte of the dummy read will be stored in RBUF0/1, but RDV0/1 will not be set. Therefore the dummy read will not generate a receive interrupt and the data byte will not be stored into the receive FIFO.

If the transfer direction has changed in the current frame (master read access), the transmit data request (TDF = 000<sub>B</sub>) is not possible and won't be accepted (leading to a wrong TDF Code indication).

**Table 15-14 Valid TDF Codes Overview**

<b>Frame Position</b>	<b>Valid TDF Codes</b>
First TDF code (master idle)	Start (100 <sub>B</sub> )
Read transfer: second TDF code (after start or repeated start)	Receive with acknowledge (010 <sub>B</sub> ) or receive with not-acknowledge (011 <sub>B</sub> )
Write transfer: second TDF code (after start or repeated start)	Transmit (000 <sub>B</sub> ), repeated start (101 <sub>B</sub> ), or stop (110 <sub>B</sub> )
Read transfer: third and subsequent TDF code after acknowledge	Receive with acknowledge (010 <sub>B</sub> ) or receive with not-acknowledge (011 <sub>B</sub> )
Read transfer: third and subsequent TDF code after not-acknowledge	Repeated start (101 <sub>B</sub> ) or stop (110 <sub>B</sub> )
Write transfer: third and subsequent TDF code	Transmit (000 <sub>B</sub> ), repeated start (101 <sub>B</sub> ), or stop (110 <sub>B</sub> )

- First TDF code:  
A master transfer starts with the TDF start code (100<sub>B</sub>). All other codes are ignored, but no WTDF error will be indicated.
- TDF code after a start (100<sub>B</sub>) or repeated start code (101<sub>B</sub>) in case of a read access:  
If a master-read transfer is started (determined by the LSB of the address byte = 1), the transfer direction of SDA changes and the slave will actively drive the data line. In this case, only the codes 010<sub>B</sub> and 011<sub>B</sub> are valid. To abort the transfer in case of a wrong code, a dummy read must be performed by the master before the STOP condition can be generated.

**Universal Serial Interface Channel (USIC)**

- TDF code after a start ( $100_B$ ) or repeated start code ( $101_B$ ) in case of a write access:  
If a master-write transfer is started (determined by the LSB of the address byte = 0), the master still owns the SDA line. In this case, the transmit ( $000_B$ ), repeated start ( $101_B$ ) and stop ( $110_B$ ) codes are valid. The other codes are considered as wrong. To abort the transfer in case of a wrong code, the STOP condition is generated immediately.
- TDF code of the third and subsequent command in case of a read access with acknowledged previous data byte:  
If a master-read transfer is started (determined by the LSB of the address byte), the transfer direction of SDA changes and the slave will actively drive the data line. To force the slave to release the SDA line, the master has to not-acknowledge a byte transfer. In this case, only the receive codes  $010_B$  and  $011_B$  are valid. To abort the transfer in case of a wrong code, a dummy read must be performed by the master before the STOP condition can be generated.
- TDF code of the third and subsequent command in case of a read access with a not-acknowledged previous data byte:  
If a master-read transfer is started (determined by the LSB of the address byte), the transfer direction of SDA changes and the slave will actively drive the data line. To force the slave to release the SDA line, the master has to not-acknowledge a byte transfer. In this case, only the restart ( $101_B$ ) and stop code ( $110_B$ ) are valid. To abort the transfer in case of a wrong code, the STOP condition is generated immediately.
- TDF code of the third and subsequent command in case of a write access:  
If a master-write transfer is started (determined by the LSB of the address byte), the master still owns the SDA line. In this case, the transmit ( $000_B$ ), repeated start ( $101_B$ ) and stop ( $110_B$ ) codes are valid. The other codes are considered as wrong. To abort the transfer in case of a wrong code, the STOP condition is generated immediately.
- After a master device has received a non-acknowledge from a slave device, a stop condition will be sent out automatically, except if the following TDF code requests a repeated start condition. In this case, the TDF code is taken into account, whereas all other TDF codes are ignored.



Universal Serial Interface Channel (USIC)

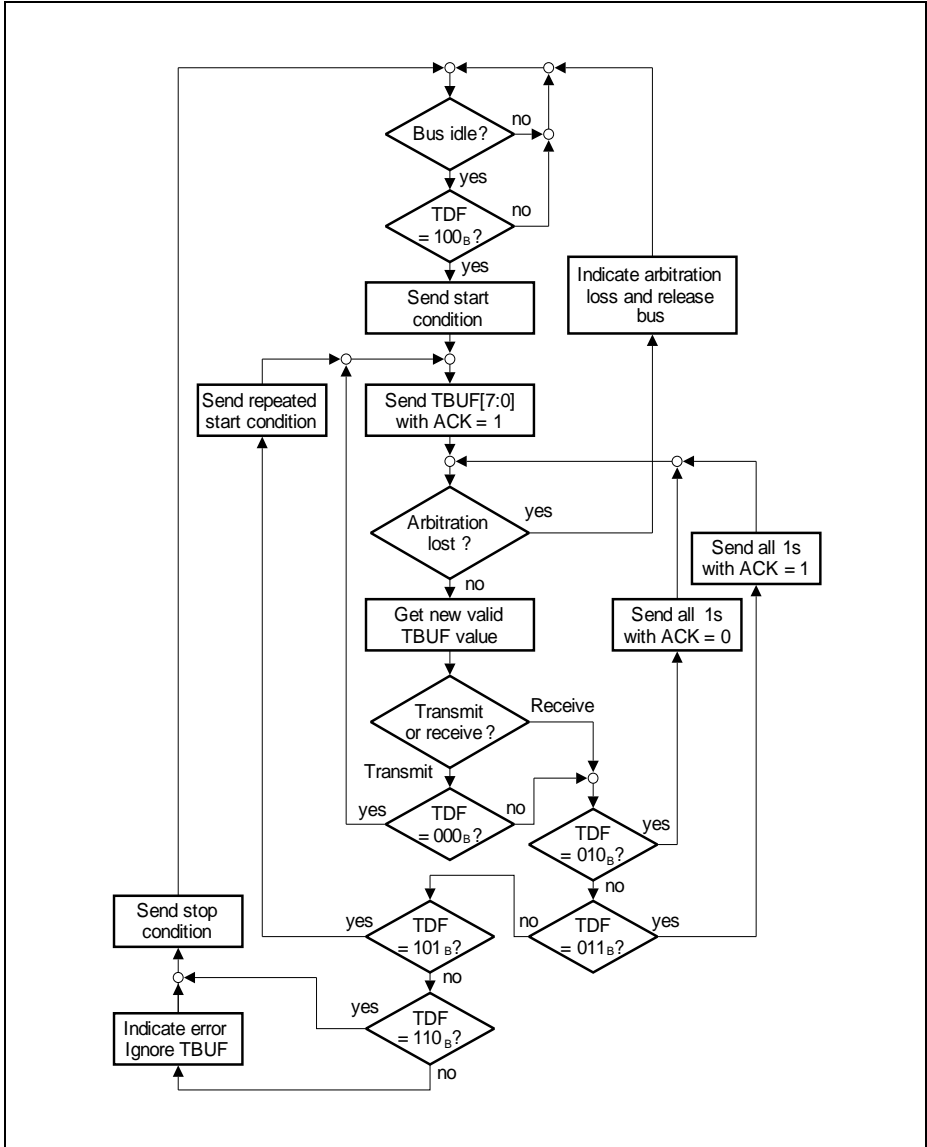


Figure 15-56 IIC Master Transmission

**Universal Serial Interface Channel (USIC)**

**15.5.4.3 Master Transmit/Receive Modes**

In master transmit mode, the IIC sends a number of data bytes to a slave receiver. The TDF code sequence for the master transmit mode is shown in [Table 15-15](#).

**Table 15-15 TDF Code Sequence for Master Transmit**

<b>TDF Code Sequence</b>	<b>TBUF[10:8] (TDF Code)</b>	<b>TBUF[7:0]</b>	<b>IIC Response</b>	<b>Interrupt Events</b>
1st code	100 <sub>B</sub>	Slave address + write bit	Send START condition, slave address and write bit	SCR: Indicates a START condition is detected TBIF: Next word can be written to TBUF
2nd code	000 <sub>B</sub>	Data or 2nd slave address byte	Send data or 2nd slave address byte	TBIF: Next word can be written to TBUF
Subsequent codes for data transmit	000 <sub>B</sub>	Data	Send data	TBIF: Next word can be written to TBUF
Last code	110 <sub>B</sub>	Don't care	Send STOP condition	PCR: Indicates a STOP condition is detected

In master receive mode, the IIC receives a number of data bytes from a slave transmitter. The TDF code sequence for the master receive 7-bit and 10-bit addressing modes are shown in [Table 15-16](#) and [Table 15-17](#).

**Table 15-16 TDF Code Sequence for Master Receive (7-bit Addressing Mode)**

<b>TDF Code Sequence</b>	<b>TBUF[10:8] (TDF Code)</b>	<b>TBUF[7:0]</b>	<b>IIC Response</b>	<b>Interrupt Events</b>
1st code	100 <sub>B</sub>	Slave address + read bit	Send START condition, slave address and read bit	SCR: Indicates a START condition is detected TBIF: Next word can be written to TBUF
2nd code	010 <sub>B</sub>	Don't care	Receive data and send ACK bit	TBIF: Next word can be written to TBUF AIF: First data received can be read

**Universal Serial Interface Channel (USIC)**

**Table 15-16 TDF Code Sequence for Master Receive (7-bit Addressing Mode)**

<b>TDF Code Sequence</b>	<b>TBUF[10:8] (TDF Code)</b>	<b>TBUF[7:0]</b>	<b>IIC Response</b>	<b>Interrupt Events</b>
Subsequent codes for data receive	010 <sub>B</sub>	Don't care	Receive data and send ACK bit	TBIF: Next word can be written to TBUF RIF: Subsequent data received can be read
Code for last data to be received	011 <sub>B</sub>	Don't care	Receive data and send NACK bit	TBIF: Next word can be written to TBUF RIF: Last data received can be read
Last code	110 <sub>B</sub>	Don't care	Send STOP condition	PCR: Indicates a STOP condition is detected

**Table 15-17 TDF Code Sequence for Master Receive (10-bit Addressing Mode)**

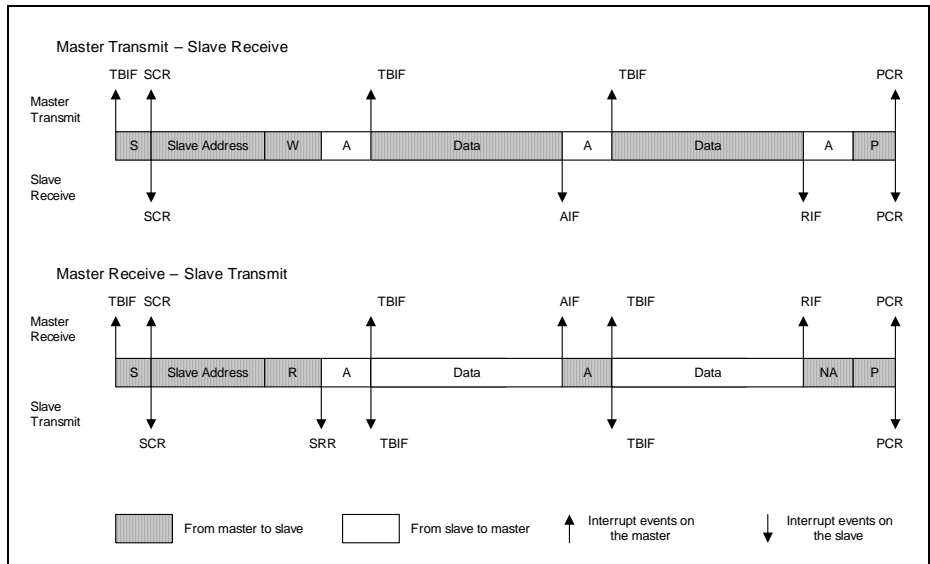
<b>TDF Code Sequence</b>	<b>TBUF[10:8] (TDF Code)</b>	<b>TBUF[7:0]</b>	<b>IIC Response</b>	<b>Interrupt Events</b>
1st code	100 <sub>B</sub>	Slave address (1st byte) + write bit	Send START condition, slave address (1st byte) and write bit	SCR: Indicates a START condition is detected TBIF: Next word can be written to TBUF
2nd code	000 <sub>B</sub>	Slave address (2nd byte)	Send address (2nd byte)	TBIF: Next word can be written to TBUF
3rd code	101 <sub>B</sub>	1st slave address + read bit	Send repeated START condition, slave address (1st byte) and read bit	RSCR: Indicates a repeated START condition is detected TBIF: Next word can be written to TBUF
4th code	010 <sub>B</sub>	Don't care	Receive data and send ACK bit	TBIF: Next word can be written to TBUF AIF: First data received can be read
Subsequent codes for data receive	010 <sub>B</sub>	Don't care	Receive data and send ACK bit	TBIF: Next word can be written to TBUF RIF: Subsequent data received can be read

**Universal Serial Interface Channel (USIC)**

**Table 15-17 TDF Code Sequence for Master Receive (10-bit Addressing Mode)**

TDF Code Sequence	TBUF[10:8] (TDF Code)	TBUF[7:0]	IIC Response	Interrupt Events
Code for last data to be received	011 <sub>B</sub>	Don't care	Receive data and send NACK bit	TBIF: Next word can be written to TBUF RIF: Last data received from slave can be read
Last code	110 <sub>B</sub>	Don't care	Send STOP condition	PCR: Indicates a STOP condition is detected

**Figure 15-57** shows the interrupt events during the master transmit-slave receive and master receive/slave transmit sequences.



**Figure 15-57 Interrupt Events on Data Transfers**

**15.5.4.4 Slave Transmit/Receive Modes**

In slave receive mode, no TDF code needs to be written and data reception is indicated by the alternate receive (AIF) or receive (RIF) events.

In slave transmit mode, upon receiving its own slave address or general call address if this option is enabled, a slave read request event (SRR) will be triggered. The slave IIC then writes the TDF code 001<sub>B</sub> and the requested data to TBUF to transmit the data to

## Universal Serial Interface Channel (USIC)

the master. The slave does not check if the master reply with an ACK or NACK to the transmitted data.

In both cases, the data transfer is terminated by the master sending a STOP condition, which is indicated by a PCR event. See also [Figure 15-57](#).

### 15.5.5 IIC Protocol Registers

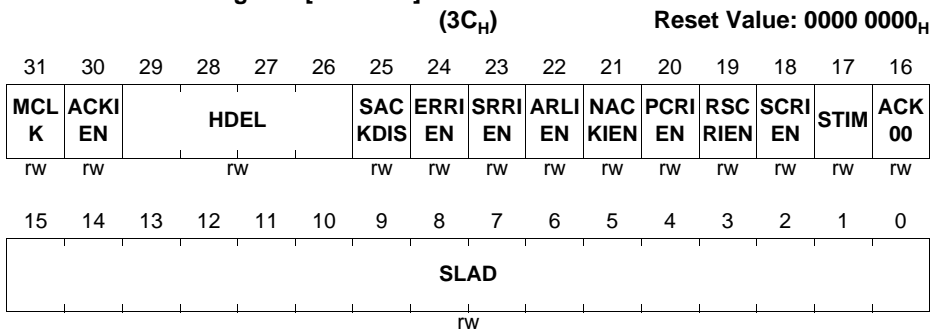
In IIC mode, the registers PCR and PSR handle IIC related information.

#### 15.5.5.1 IIC Protocol Control Registers

In IIC mode, the PCR register bits or bit fields are defined as described in this section.

#### PCR

##### Protocol Control Register [IIC Mode]



Field	Bits	Type	Description
<b>SLAD</b>	[15:0]	rw	<b>Slave Address</b> This bit field contains the programmed slave address. The corresponding bits in the first received address byte are compared to the bits SLAD[15:9] to check for address match. If SLAD[15:11] = 11110 <sub>B</sub> , then the second address byte is also compared to SLAD[7:0].
<b>ACK00</b>	16	rw	<b>Acknowledge 00<sub>H</sub></b> This bit defines if a slave device should be sensitive to the slave address 00 <sub>H</sub> . 0 <sub>B</sub> The slave device is not sensitive to this address. 1 <sub>B</sub> The slave device is sensitive to this address.

**Universal Serial Interface Channel (USIC)**

<b>Field</b>	<b>Bits</b>	<b>Type</b>	<b>Description</b>
<b>STIM</b>	17	rw	<p><b>Symbol Timing</b> This bit defines how many time quanta are used in a symbol.</p> <p>0<sub>B</sub> A symbol contains 10 time quanta. The timing is adapted for standard mode (100 kBaud).</p> <p>1<sub>B</sub> A symbol contains 25 time quanta. The timing is adapted for fast mode (400 kBaud).</p>
<b>SCRIEN</b>	18	rw	<p><b>Start Condition Received Interrupt Enable</b> This bit enables the generation of a protocol interrupt if a start condition is detected.</p> <p>0<sub>B</sub> The start condition interrupt is disabled.</p> <p>1<sub>B</sub> The start condition interrupt is enabled.</p>
<b>RSCRIEN</b>	19	rw	<p><b>Repeated Start Condition Received Interrupt Enable</b> This bit enables the generation of a protocol interrupt if a repeated start condition is detected.</p> <p>0<sub>B</sub> The repeated start condition interrupt is disabled.</p> <p>1<sub>B</sub> The repeated start condition interrupt is enabled.</p>
<b>PCRIEN</b>	20	rw	<p><b>Stop Condition Received Interrupt Enable</b> This bit enables the generation of a protocol interrupt if a stop condition is detected.</p> <p>0<sub>B</sub> The stop condition interrupt is disabled.</p> <p>1<sub>B</sub> The stop condition interrupt is enabled.</p>
<b>NACKIEN</b>	21	rw	<p><b>Non-Acknowledge Interrupt Enable</b> This bit enables the generation of a protocol interrupt if a non-acknowledge is detected by a master.</p> <p>0<sub>B</sub> The non-acknowledge interrupt is disabled.</p> <p>1<sub>B</sub> The non-acknowledge interrupt is enabled.</p>
<b>ARLIEN</b>	22	rw	<p><b>Arbitration Lost Interrupt Enable</b> This bit enables the generation of a protocol interrupt if an arbitration lost event is detected.</p> <p>0<sub>B</sub> The arbitration lost interrupt is disabled.</p> <p>1<sub>B</sub> The arbitration lost interrupt is enabled.</p>
<b>SRRIEN</b>	23	rw	<p><b>Slave Read Request Interrupt Enable</b> This bit enables the generation of a protocol interrupt if a slave read request is detected.</p> <p>0<sub>B</sub> The slave read request interrupt is disabled.</p> <p>1<sub>B</sub> The slave read request interrupt is enabled.</p>

**Universal Serial Interface Channel (USIC)**

<b>Field</b>	<b>Bits</b>	<b>Type</b>	<b>Description</b>
<b>ERRIEN</b>	24	rw	<p><b>Error Interrupt Enable</b></p> <p>This bit enables the generation of a protocol interrupt if an IIC error condition is detected (indicated by PSR.ERR or PSR.WTDF).</p> <p>0<sub>B</sub> The error interrupt is disabled. 1<sub>B</sub> The error interrupt is enabled.</p>
<b>SACKDIS</b>	25	rw	<p><b>Slave Acknowledge Disable</b></p> <p>This bit disables the generation of an active acknowledge signal for a slave device (active acknowledge = 0 level). Once set by software, it is automatically cleared with each (repeated) start condition. If this bit is set after a byte has been received (indicated by an interrupt) but before the next acknowledge bit has started, the next acknowledge bit will be sent with passive level. This would indicate that the receiver does not accept more bytes. As a result, a minimum of 2 bytes will be received if the first receive interrupt is used to set this bit.</p> <p>0<sub>B</sub> The generation of an active slave acknowledge is enabled (slave acknowledge with 0 level = more bytes can be received). 1<sub>B</sub> The generation of an active slave acknowledge is disabled (slave acknowledge with 1 level = reception stopped).</p>
<b>HDEL</b>	[29:26]	rw	<p><b>Hardware Delay</b></p> <p>This bit field defines the delay used to compensate the internal treatment of the SCL signal (see <a href="#">Page 15-117</a>) in order to respect the SDA hold time specified for the IIC protocol.</p>
<b>ACKIEN</b>	30	rw	<p><b>Acknowledge Interrupt Enable</b></p> <p>This bit enables the generation of a protocol interrupt if an acknowledge is detected by a master.</p> <p>0<sub>B</sub> The acknowledge interrupt is disabled. 1<sub>B</sub> The acknowledge interrupt is enabled.</p>
<b>MCLK</b>	31	rw	<p><b>Master Clock Enable</b></p> <p>This bit enables generation of the master clock MCLK (not directly used for IIC protocol, can be used as general frequency output).</p> <p>0<sub>B</sub> The MCLK generation is disabled and MCLK is 0. 1<sub>B</sub> The MCLK generation is enabled.</p>

**Universal Serial Interface Channel (USIC)**

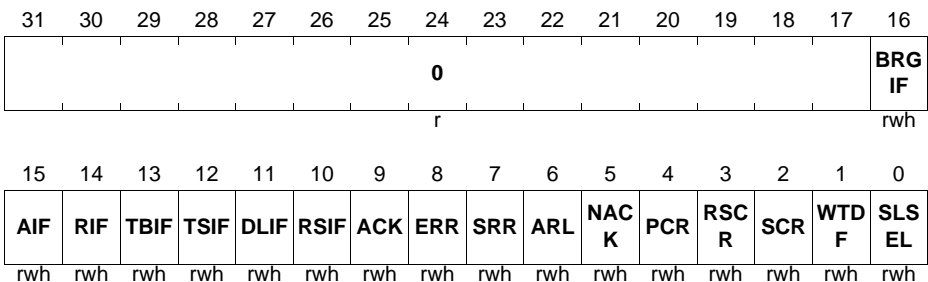
**15.5.5.2 IIC Protocol Status Register**

The following PSR status bits or bit fields are available in IIC mode. Please note that the bits in register PSR are not cleared by hardware.

The flags in the PSR register can be cleared by writing a 1 to the corresponding bit position in register PSCR. Writing a 1 to a bit position in PSR sets the corresponding flag, but does not lead to further actions (no interrupt generation). Writing a 0 has no effect. These flags should be cleared by software before enabling a new protocol.

**PSR**

**Protocol Status Register [IIC Mode] (48<sub>H</sub>)** **Reset Value: 0000 0000<sub>H</sub>**



Field	Bits	Type	Description
<b>SLSEL</b>	0	rwh	<p><b>Slave Select</b></p> <p>This bit indicates that this device has been selected as slave.</p> <p>0<sub>B</sub> The device is not selected as slave. 1<sub>B</sub> The device is selected as slave.</p>
<b>WTDF</b>	1	rwh	<p><b>Wrong TDF Code Found<sup>1)</sup></b></p> <p>This bit indicates that an unexpected/wrong TDF code has been found. A protocol interrupt can be generated if PCR.ERRIEN = 1.</p> <p>0<sub>B</sub> A wrong TDF code has not been found. 1<sub>B</sub> A wrong TDF code has been found.</p>
<b>SCR</b>	2	rwh	<p><b>Start Condition Received<sup>1)</sup></b></p> <p>This bit indicates that a start condition has been detected on the IIC bus lines. A protocol interrupt can be generated if PCR.SCRIEN = 1.</p> <p>0<sub>B</sub> A start condition has not yet been detected. 1<sub>B</sub> A start condition has been detected.</p>



**Universal Serial Interface Channel (USIC)**

<b>Field</b>	<b>Bits</b>	<b>Type</b>	<b>Description</b>
<b>RSCR</b>	3	rwh	<p><b>Repeated Start Condition Received<sup>1)</sup></b>            This bit indicates that a repeated start condition has been detected on the IIC bus lines. A protocol interrupt can be generated if PCR.RSCRIEN = 1.</p> <p>0<sub>B</sub> A repeated start condition has not yet been detected.            1<sub>B</sub> A repeated start condition has been detected.</p>
<b>PCR</b>	4	rwh	<p><b>Stop Condition Received<sup>1)</sup></b>            This bit indicates that a stop condition has been detected on the IIC bus lines. A protocol interrupt can be generated if PCR.PCRIEN = 1.</p> <p>0<sub>B</sub> A stop condition has not yet been detected.            1<sub>B</sub> A stop condition has been detected.</p>
<b>NACK</b>	5	rwh	<p><b>Non-Acknowledge Received<sup>1)</sup></b>            This bit indicates that a non-acknowledge has been received in master mode. This bit is not set in slave mode. A protocol interrupt can be generated if PCR.NACKIEN = 1.</p> <p>0<sub>B</sub> A non-acknowledge has not been received.            1<sub>B</sub> A non-acknowledge has been received.</p>
<b>ARL</b>	6	rwh	<p><b>Arbitration Lost<sup>1)</sup></b>            This bit indicates that an arbitration has been lost. A protocol interrupt can be generated if PCR.ARLIEN = 1.</p> <p>0<sub>B</sub> An arbitration has not been lost.            1<sub>B</sub> An arbitration has been lost.</p>
<b>SRR</b>	7	rwh	<p><b>Slave Read Request<sup>1)</sup></b>            This bit indicates that a slave read request has been detected. It becomes active to request the first data byte to be made available in the transmit buffer. For further consecutive data bytes, the transmit buffer issues more interrupts. For the end of the transfer, the master transmitter sends a stop condition. A protocol interrupt can be generated if PCR.SRRIEN = 1.</p> <p>0<sub>B</sub> A slave read request has not been detected.            1<sub>B</sub> A slave read request has been detected.</p>

**Universal Serial Interface Channel (USIC)**

Field	Bits	Type	Description
<b>ERR</b>	8	rwh	<b>Error<sup>1)</sup></b> This bit indicates that an IIC error (frame format or TDF code) has been detected. A protocol interrupt can be generated if PCR.ERRIEN = 1. 0 <sub>B</sub> An IIC error has not been detected. 1 <sub>B</sub> An IIC error has been detected.
<b>ACK</b>	9	rwh	<b>Acknowledge Received<sup>1)</sup></b> This bit indicates that an acknowledge has been received in master mode. This bit is not set in slave mode. A protocol interrupt can be generated if PCR.ACKIEN = 1. 0 <sub>B</sub> An acknowledge has not been received. 1 <sub>B</sub> An acknowledge has been received.
<b>RSIF</b>	10	rwh	<b>Receiver Start Indication Flag</b> 0 <sub>B</sub> A receiver start event has not occurred. 1 <sub>B</sub> A receiver start event has occurred.
<b>DLIF</b>	11	rwh	<b>Data Lost Indication Flag</b> 0 <sub>B</sub> A data lost event has not occurred. 1 <sub>B</sub> A data lost event has occurred.
<b>TSIF</b>	12	rwh	<b>Transmit Shift Indication Flag</b> 0 <sub>B</sub> A transmit shift event has not occurred. 1 <sub>B</sub> A transmit shift event has occurred.
<b>TBIF</b>	13	rwh	<b>Transmit Buffer Indication Flag</b> 0 <sub>B</sub> A transmit buffer event has not occurred. 1 <sub>B</sub> A transmit buffer event has occurred.
<b>RIF</b>	14	rwh	<b>Receive Indication Flag</b> 0 <sub>B</sub> A receive event has not occurred. 1 <sub>B</sub> A receive event has occurred.
<b>AIF</b>	15	rwh	<b>Alternative Receive Indication Flag</b> 0 <sub>B</sub> An alternative receive event has not occurred. 1 <sub>B</sub> An alternative receive event has occurred.
<b>BRGIF</b>	16	rwh	<b>Baud Rate Generator Indication Flag</b> 0 <sub>B</sub> A baud rate generator event has not occurred. 1 <sub>B</sub> A baud rate generator event has occurred.
<b>0</b>	[31:17]	r	<b>Reserved</b> Returns 0 if read; not modified in IIC mode.

1) This status bit can generate a protocol interrupt (see [Page 15-21](#)). The general interrupt status flags are described in the general interrupt chapter.

**Universal Serial Interface Channel (USIC)**

**15.6 Inter-IC Sound Bus Protocol (IIS)**

This chapter describes how the USIC module handles the IIS protocol. This serial protocol can handle reception and transmission of synchronous data frames between a device operating in master mode and a device in slave mode. An IIS connection based on a USIC communication channel supports half-duplex and full-duplex data transfers. The IIS mode is selected by  $CCR.MODE = 0011_B$  with  $CCFG.IIS = 1$  (IIS mode is available).

**15.6.1 Introduction**

The IIS protocol is a synchronous serial communication protocol mainly for audio and infotainment applications [8].

**15.6.1.1 Signal Description**

A connection between an IIS master and an IIS slave is based on the following signals:

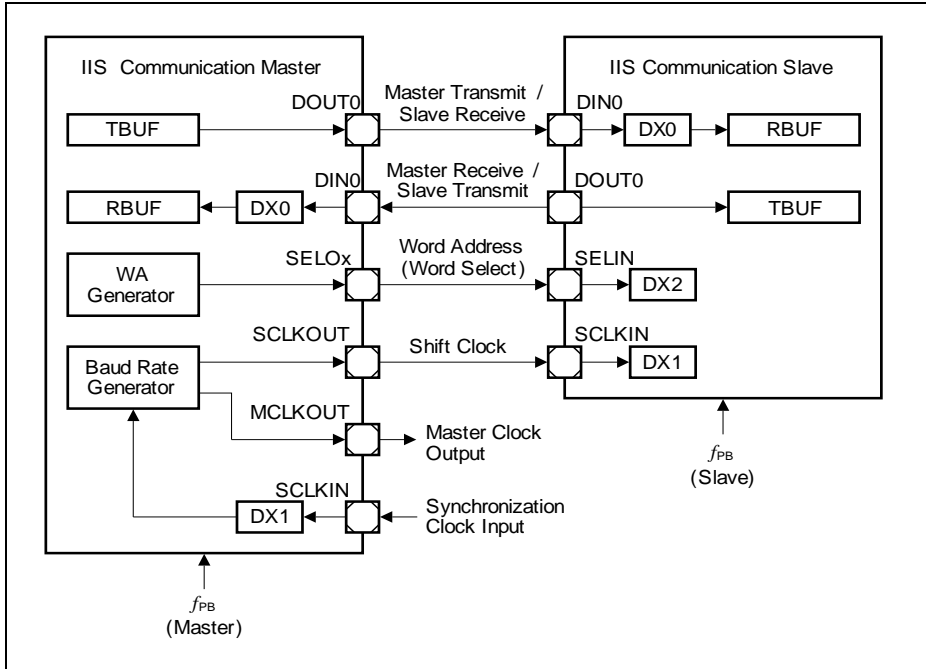
- A shift clock signal SCK, generated by the transfer master. It is permanently generated while an IIS connection is established, also while no valid data bits are transferred.
- A word address signal WA (also named WS), generated by the transfer master. It indicates the beginning of a new data word and the targeted audio channel (e.g. left/right). The word address output signal WA is available on all SELOx outputs if the WA generation is enabled (by  $PCR.WAGEN = 1$  for the transfer master). The WA signal changes synchronously to the falling edges of the shift clock.
- If the transmitter is the IIS master device, it generates a master transmit slave receive data signal. The data changes synchronously to the falling edges of the shift clock.
- If the transmitter is the IIS slave device, it generates a master receive slave transmit data signal. The data changes synchronously to the falling edges of the shift clock.

The transmitter part and the receiver part of the USIC communication channel can be used together to establish a full-duplex data connection between an IIS master and a slave device.

**Table 15-18 IIS IO Signals**

<b>IIS Mode</b>	<b>Receive Data</b>	<b>Transmit Data</b>	<b>Shift Clock</b>	<b>Word Address</b>
Master	Input DIN0, handled by DX0	Output DOUT0	Output SCLKOUT	Output(s) SELOx
Slave	Input DIN0, handled by DX0	Output DOUT0	Input SCLKIN, handled by DX1	Input SELIN, handled by DX2

**Universal Serial Interface Channel (USIC)**



**Figure 15-58 IIS Signals**

Two additional signals are available for the USIC IIS communication master:

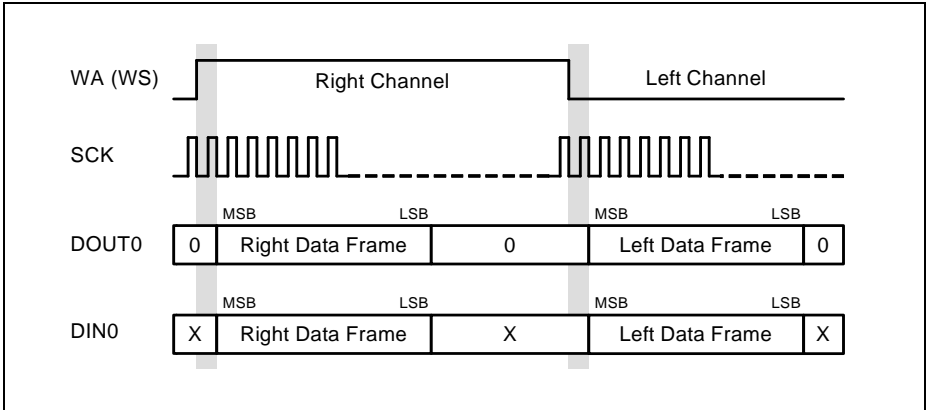
- A master clock output signal MCLKOUT with a fixed phase relation to the shift clock to support oversampling for audio components. It can also be used as master clock output of a communication network with synchronized IIS connections.
- A synchronization clock input SCLKIN for synchronization of the shift clock generation to an external frequency to support audio frequencies that can not be directly derived from the system clock  $f_{PB}$  of the communication master. It can be used as master clock input of a communication network with synchronized IIS connections.

**15.6.1.2 Protocol Overview**

An IIS connection supports transfers for two different data frames via the same data line, e.g. a data frames for the left audio channel and a data frame for the right audio channel. The word address signal WA is used to distinguish between the different data frames. Each data frame can consist of several data words.

**Universal Serial Interface Channel (USIC)**

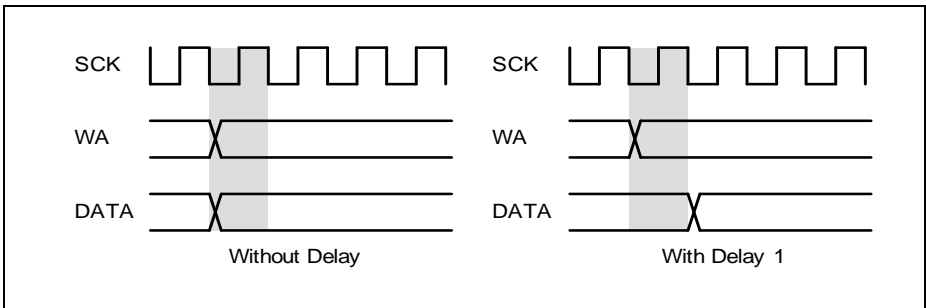
In a USIC communication channel, data words are tagged for being transmitted for the left or for the right channel. Also the received data words contain a tag identifying the WA state when the data has been received.



**Figure 15-59 Protocol Overview**

**15.6.1.3 Transfer Delay**

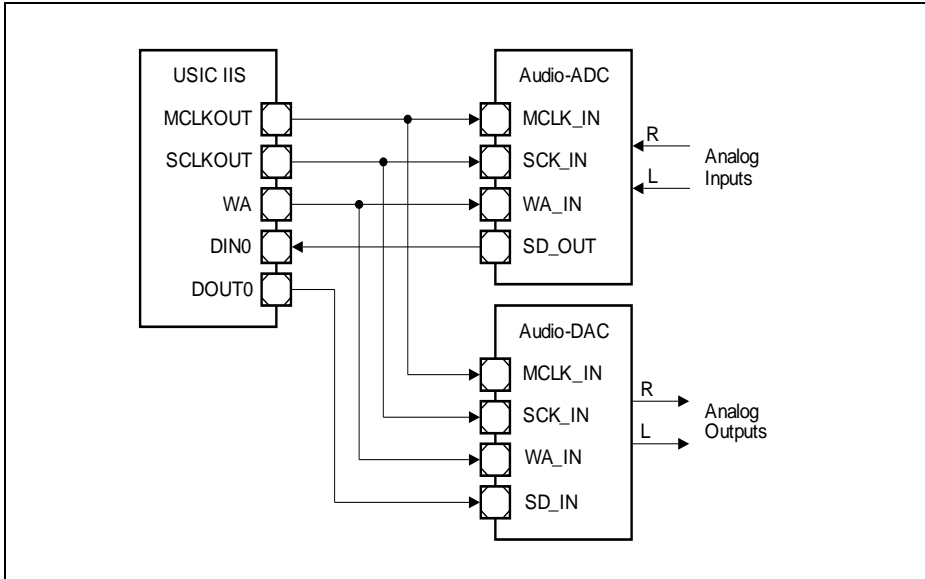
The transfer delay feature allows the transfer of data (transmission and reception) with a programmable delay (counted in shift clock periods).



**Figure 15-60 Transfer Delay for IIS**

**15.6.1.4 Connection of External Audio Components**

The IIS signals can be used to communicate with external audio devices (such as Codecs) or other audio data sources/destinations.



**Figure 15-61 Connection of External Audio Devices**

In some applications, especially for Audio-ADCs or Audio-DACs, a master clock signal is required with a fixed phase relation to the shift clock signal. The frequency of MCLKOUT is a multiple of the shift frequency SCLKOUT. This factor defines the oversampling factor of the external device (commonly used values: 256 or 384).

## 15.6.2 Operating the IIS

This chapter contains IIS issues, that are of general interest and not directly linked to master mode or slave mode.

### 15.6.2.1 Frame Length and Word Length Configuration

After each change of the WA signal, a complete data frame is intended to be transferred (frame length  $\leq$  system word length). The number of data bits transferred after a change of signal WA is defined by SCTR.FLE. A data frame can consist of several data words with a data word length defined by SCTR.WLE. The changes of signal WA define the system word length as the number of SCLK cycles between two changes of WA (number of bits available for the right channel and same number available for the left channel).

If the system word length is longer than the frame length defined by SCTR.FLE, the additional bits are transmitted with passive data level (SCTR.PDL). If the system word

---

**Universal Serial Interface Channel (USIC)**

length is smaller than the device frame length, not all LSBs of the transmit data can be transferred.

It is recommended to program bits WLEMD, FLEMD and SELMD in register TCSR to 0.

### 15.6.2.2 Automatic Shadow Mechanism

The baud rate and shift control setting are internally kept constant while a data frame is transferred by an automatic shadow mechanism. The registers can be programmed all the time with new settings that are taken into account for the next data frame. During a data frame, the applied (shadowed) setting is not changed, although new values have been written after the start of the data frame. The setting is internally “frozen” with the start of each data frame.

Although this shadow mechanism being implemented, it is recommended to change the baud rate and shift control setting only while the IIS protocol is switched off.

### 15.6.2.3 Mode Control Behavior

In IIS mode, the following kernel modes are supported:

- Run Mode 0/1:  
Behavior as programmed, no impact on data transfers.
- Stop Mode 0/1:  
Bit PCR.WAGEN is internally considered as 0 (the bit itself is not changed). If WAGEN = 1, then the current system word cycle is finished and then the WA generation is stopped, but PSR.END is not set. The complete data frame is finished before entering stop mode, including a possible delay due to PCR.TDEL.  
When leaving a stop mode with WAGEN = 1, the WA generation starts from the beginning.

### 15.6.2.4 Transfer Delay

The transfer delay can be used to synchronize a data transfer to an event (e.g. a change of the WA signal). This event has to be synchronously generated to the falling edge of the shift clock SCK (like the change of the transmit data), because the input signal for the event is directly sampled in the receiver (as a result, the transmitter can use the detection information with its next edge).

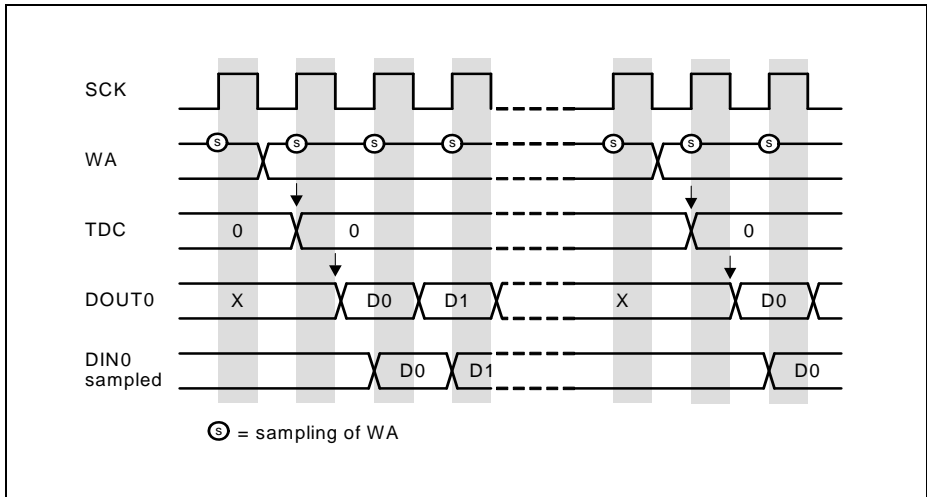
Event signals that are asynchronous to the shift clock while the shift clock is running must not be used. In the example in [Figure 15-60](#), the event (change of signal WA) is generated by the transfer master and as a result, is synchronous to the shift clock SCK. With the rising edge of SCK, signal WA is sampled and checked for a change. If a change is detected, a transfer delay counter TDC is automatically loaded with its programmable reload value (PCR.TDEL), otherwise it is decremented with each rising edge of SCK until it reaches 0, where it stops. The transfer itself is started if the value of TDC has become 0. This can happen under two conditions:

**Universal Serial Interface Channel (USIC)**

- TDC is reloaded with a PCR.TDEL = 0 when the event is detected
- TDC has reached 0 while counting down

The transfer delay counter is internal to the IIS protocol pre-processor and can not be observed by software. The transfer delay in SCK cycles is given by PCR.TDEL+1.

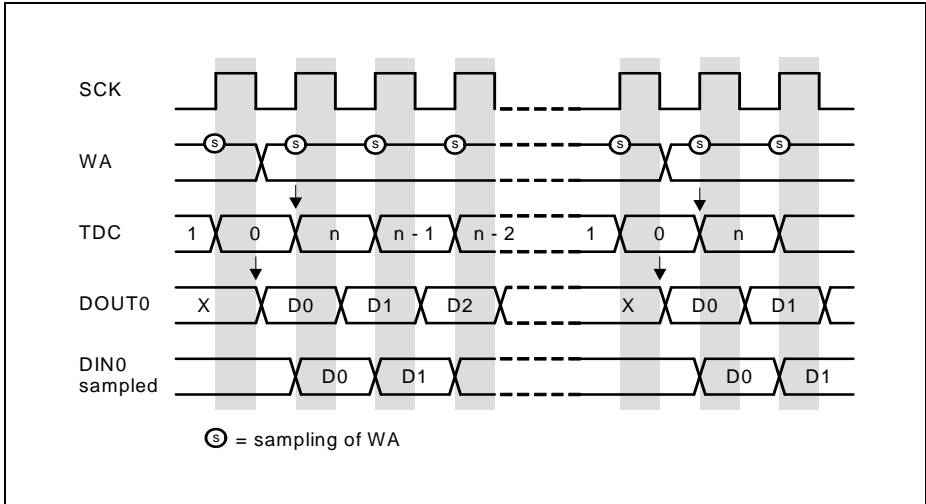
In the example in [Figure 15-62](#), the reload value PCR.TDEL for TDC is 0. When the samples taken on receiver side show the change of the WA signal, the counter TDC is reloaded. If the reload value is 0, the data transfer starts with 1 shift clock cycle delay compared to the change of WA.



**Figure 15-62 Transfer Delay with Delay 1**

The ideal case without any transfer delay is shown in [Figure 15-63](#). The WA signal changes and the data output value become valid at the same time. This implies that the transmitter “knows” in advance that the event signal will change with the next rising edge of TCLK. This is achieved by delaying the data transmission after the previously detected WA change the system word length minus 1.





**Figure 15-63 No Transfer Delay**

If the end of the transfer delay is detected simultaneously to change of WA, the transfer is started and the delay counter is reloaded with PCR.TDEL. This allows to run the USIC as IIS device without any delay. In this case, internally the delay from the previous event elapses just at the moment when a new event occurs. If PCR.TDEL is set to a value bigger than the system word length, no transfer takes place.

### 15.6.2.5 Parity Mode

Parity generation is not supported in IIS mode and bit field CCR.PM = 00<sub>B</sub> has to be programmed.

### 15.6.2.6 Transfer Mode

In IIS mode, bit field SCTR.TRM = 11<sub>B</sub> has to be programmed to allow data transfers. Setting SCTR.TRM = 00<sub>B</sub> disables and stops the data transfer immediately.

### 15.6.2.7 Data Transfer Interrupt Handling

The data transfer interrupts indicate events related to IIS frame handling.

- Transmit buffer interrupt TBI:  
Bit PSR.TBIF is set after the start of first data bit of a data word.
- Transmit shift interrupt TSI:  
Bit PSR.TSIF is set after the start of the last data bit of a data word.

---

**Universal Serial Interface Channel (USIC)**

- Receiver start interrupt RSI:  
Bit PSR.RSIF is set after the reception of the first data bit of a data word.  
With this event, bit TCSR.TDV is cleared and new data can be loaded to the transmit buffer.
- Receiver interrupt RI and alternative interrupt AI:  
Bit PSR.RIF is set at after the reception of the last data bit of a data word with WA = 0.  
Bit RBUFSSR.SOF indicates whether the received data word has been the first data word of a new data frame.  
Bit PSR.AIF is set at after the reception of the last data bit of a data word with WA = 1.  
Bit RBUFSSR.SOF indicates whether the received data word has been the first data word of a new data frame.

### 15.6.2.8 Baud Rate Generator Interrupt Handling

The baud rate generator interrupt indicate that the capture mode timer has reached its maximum value. With this event, the bit PSR.BRGIF is set.

### 15.6.2.9 Protocol-Related Argument and Error

In order to distinguish between data words received for the left or the right channel, the IIS protocol pre-processor samples the level of the WA input (just after the WA transition) and propagates it as protocol-related error (although it is not an error, but an indication) to the receive buffer status register at the bit position RBUFSSR[9]. This bit position defines if either a standard receive interrupt (if RBUFSSR[9] = 0) or an alternative receive interrupt (if RBUFSSR[9] = 1) becomes activated when a new data word has been received. Incoming data can be handled by different interrupts for the left and the right channel if the corresponding events are directed to different interrupt nodes. Flag PAR is always 0.

### 15.6.2.10 Transmit Data Handling

The IIS protocol pre-processor allows to distinguish between the left and the right channel for data transmission. Therefore, bit TCSR.WA indicates on which channel the data in the buffer will be transmitted. If TCSR.WA = 0, the data will be transmitted after a falling edge of WA. If TCSR.WA = 1, the data will be transmitted after a rising edge of WA. The WA value sampled after the WA transition is considered to distinguish between both channels (referring to PSR.WA).

Bit TCSR.WA can be automatically updated by the transmit control information TC[4] for each data word if TCSR.WAMD = 1. In this case, data written to TBUF[15:0] (or IN[15:0] if a FIFO data buffer is used) is considered as left channel data, whereas data written to TBUF[31:16] (or IN[31:16] if a FIFO data buffer is used) is considered as right channel data.

### 15.6.2.11 Receive Buffer Handling

If a receive FIFO buffer is available ( $CCFG.RB = 1$ ) and enabled for data handling ( $RBCTR.SIZE > 0$ ), it is recommended to set  $RBCTR.RCIM = 11_B$  in IIS mode. This leads to an indication that the data word has been the first data word of a new data frame if bit  $OUTR.RCI[0] = 1$ , and the channel indication by the sampled WA value is given by  $OUTR.RCI[4]$ .

The standard receive buffer event and the alternative receive buffer event can be used for the following operation in RCI mode ( $RBCTR.RNM = 1$ ):

- A standard receive buffer event indicates that a data word can be read from OUTR that belongs to a data frame started when  $WA = 0$ .
- An alternative receive buffer event indicates that a data word can be read from OUTR that belongs to a data frame started when  $WA = 1$ .

### 15.6.2.12 Loop-Delay Compensation

The synchronous signaling mechanism of the IIS protocol being similar to the one of the SSC protocol, the closed-loop delay has to be taken into account for the application setup. In IIS mode, loop-delay compensation in master mode is also possible to achieve higher baud rates.

Please refer to the more detailed description in the SSC chapter.

## 15.6.3 Operating the IIS in Master Mode

In order to operate the IIS in master mode, the following issues have to be considered:

- Select IIS mode:  
It is recommended to configure all parameters of the IIS that do not change during run time while  $CCR.MODE = 0000_B$ . Bit field  $SCTR.TRM = 11_B$  has to be programmed. The configuration of the input stages has to be done while  $CCR.MODE = 0000_B$  to avoid unintended edges of the input signals and the IIS mode can be enabled by  $CCR.MODE = 0011_B$  afterwards.
- Pin connection for data transfer:  
Establish a connection of input stage DX0 with the selected receive data input pin ( $DIN0$ ) with  $DX0CR.INSW = 1$ . Configure a transmit data output pin ( $DOUT0$ ) for a transmitter.  
The data shift unit allowing full-duplex data transfers based on the same WA signal, the values delivered by the DX0 stage are considered as data bits (receive function can not be disabled independently from the transmitter). To receive IIS data, the transmitter does not necessarily need to be configured (no assignment of  $DOUT0$  signal to a pin).
- Baud rate generation:  
The desired baud rate setting has to be selected, comprising the fractional divider and the baud rate generator. Bit  $DX1CR.INSW = 0$  has to be programmed to use the

**Universal Serial Interface Channel (USIC)**

baud rate generator output SCLK directly as input for the data shift unit. Configure a shift clock output pin with the inverted signal SCLKOUT without additional delay (BRG.SCLKCFG = 01<sub>b</sub>).

- Word address WA generation:  
The WA generation has to be enabled by setting PCR.WAGEN = 1 and the programming of the number of shift clock cycles between the changes of WA. Bit DX2CR.INSW = 0 has to be programmed to use the WA generator as input for the data shift unit. Configure WA output pin for signal SELOx if needed.
- Data format configuration:  
The word length, the frame length, and the shift direction have to be set up according to the application requirements by programming the register SCTR. Generally, the MSB is shifted first (SCTR.SDIR = 1).  
Bit TCSR.WAMD can be set to use the transmit control information TC[4] to distinguish the data words for transmission while WA = 0 or while WA = 1.

*Note: The step to enable the alternate output port functions should only be done after the IIS mode is enabled, to avoid unintended spikes on the output.*

**15.6.3.1 Baud Rate Generation**

The baud rate is defined by the frequency of the SCLK signal (one period of  $f_{SCLK}$  represents one data bit).

If the fractional divider mode is used to generate  $f_{PIN}$ , there can be an uncertainty of one period of  $f_{PB}$  for  $f_{PIN}$ . This uncertainty does not accumulate over several SCLK cycles. As a consequence, the average frequency is reached, whereas the duty cycle of 50% of the SCLK and MCLK signals can vary by one period of  $f_{PB}$ .

In IIS applications, where the phase relation between the optional MCLK output signal and SCLK is not relevant, SCLK can be based on the frequency  $f_{PIN}$  (BRG.PPPEN = 0). In the case that a fixed phase relation between the MCLK signal and SCLK is required (e.g. when using MCLK as clock reference for external devices), the additional divider by 2 stage has to be taken into account (BRG.PPPEN = 1). This division is due to the fact that signal MCLK toggles with each cycle of  $f_{PIN}$ . Signal SCLK is then based on signal MCLK, see [Figure 15-64](#).

The adjustable integer divider factor is defined by bit field BRG.PDIV.

$$\begin{aligned}
 f_{SCLK} &= \frac{f_{PIN}}{2} \times \frac{1}{PDIV + 1} && \text{if } PPPEN = 0 \\
 f_{SCLK} &= \frac{f_{PIN}}{2 \times 2} \times \frac{1}{PDIV + 1} && \text{if } PPPEN = 1
 \end{aligned}
 \tag{15.12}$$

*Note: In the IIS protocol, the master (unit generating the shift clock and the WA signal) changes the status of its data and WA output line with the falling edge of SCK. The slave transmitter also has to transmit on falling edges. The sampling of the*

**Universal Serial Interface Channel (USIC)**

*received data is done with the rising edges of SCLK. The input stage DX1 and the SCLKOUT have to be programmed to invert the shift clock signal to fit to the internal signals.*

**15.6.3.2 WA Generation**

The word address (or word select) line WA regularly toggles after N cycles of signal SCLK. The time between the changes of WA is called system word length and can be programmed by using the following bit fields.

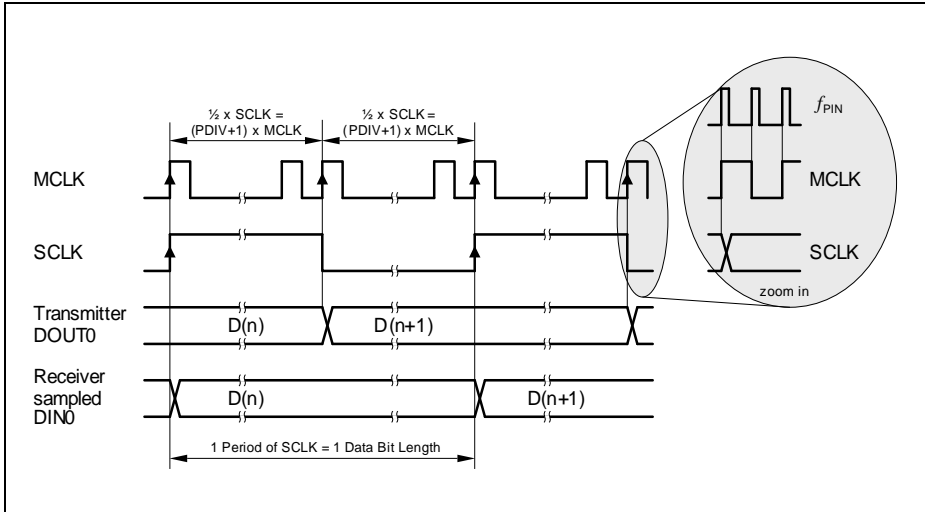
In IIS master mode, the system word length is defined by:

- BRG.CTQSEL =  $10_B$   
to base the WA toggling on SCLK
- BRG.PCTQ  
to define the number N of SCLK cycles per system word length
- BRG.DCTQ  
to define the number N of SCLK cycles per system word length

$$N = (PCTQ + 1) \times (DCTQ + 1) \tag{15.13}$$

**15.6.3.3 Master Clock Output**

The master clock signal MCLK can be generated by the master of the IIS transfer (BRG.PPPEN = 1). It is used especially to connect external Codec devices. It can be configured by bit BRG.MCLKCFG in its polarity to become the output signal MCLKOUT.



**Figure 15-64 MCLK and SCLK for IIS**

### 15.6.3.4 Protocol Interrupt Events

The following protocol-related events are generated in IIS mode and can lead to a protocol interrupt.

Please note that the bits in register PSR are not all automatically cleared by hardware and have to be cleared by software in order to monitor new incoming events.

- **WA rising/falling edge events:**  
The WA generation block indicates two events that are monitored in register PSR. Flag PSR.WAFE is set with the falling edge, flag PSR.WARE with the rising edge of the WA signal. A protocol interrupt can be generated if PCR.WAFEIEN = 1 for the falling edge, similar for PCR.WAREIEN = 1 for a rising edge.
- **WA end event:**  
The WA generation block also indicates when it has stopped the WA generation after it has been disabled by writing PCR.WAGEN = 0. A protocol interrupt can be generated if PCR.ENDIEN = 1.
- **DX2T event:**  
An activation of the trigger signal DX2T is indicated by PSR.DX2TEV = 1 and can generate a protocol interrupt if PCR.DX2TIEN = 1. This event can be evaluated instead of the WA rising/falling events if a delay compensation like in SSC mode (for details, refer to corresponding SSC section) is used.

### 15.6.4 Operating the IIS in Slave Mode

In order to operate the IIS in slave mode, the following issues have to be considered:

- **Select IIS mode:**  
It is recommended to configure all parameters of the IIS that do not change during run time while  $CCR.MODE = 0000_B$ . Bit field  $SCTR.TRM = 11_B$  has to be programmed. The configuration of the input stages has to be done while  $CCR.MODE = 0000_B$  to avoid unintended edges of the input signals and the IIS mode can be enabled by  $CCR.MODE = 0011_B$  afterwards.
- **Pin connection for data transfer:**  
Establish a connection of input stage DX0 with the selected receive data input pin (DIN0) with  $DX0CR.INSW = 1$ . Configure a transmit data output pin (DOUT0) for a transmitter.  
The data shift unit allowing full-duplex data transfers based on the same WA signal, the values delivered by the DX0 stage are considered as data bits (receive function can not be disabled independently from the transmitter). To receive IIS data, the transmitter does not necessarily need to be configured (no assignment of DOUT0 signal to a pin).  
Note that the step to enable the alternate output port functions should only be done after the IIS mode is enabled, to avoid unintended spikes on the output.
- **Pin connection for shift clock:**  
Establish a connection of input stage DX1 with the selected shift clock input pin (SCLKIN) with  $DX1CR.INSW = 1$  and with inverted polarity ( $DX1CR.DPOL = 1$ ).
- **Pin connection for WA input:**  
Establish a connection of input stage DX2 with the WA input pin (SELIN) with  $DX2CR.INSW = 1$ .
- **Baud rate generation:**  
The baud rate generator is not needed and can be switched off by the fractional divider.
- **WA generation:**  
The WA generation is not needed and can be switched off ( $PCR.WAGEN = 0$ ).

#### 15.6.4.1 Protocol Events and Interrupts

The following protocol-related event is generated in IIS mode and can lead to a protocol interrupt.

Please note that the bits in register PSR are not all automatically cleared by hardware and have to be cleared by software in order to monitor new incoming events.

- **WA rising/falling/end events:**  
The WA generation being switched off, these events are not available.
- **DX2T event:**  
An activation of the trigger signal DX2T is indicated by  $PSR.DX2TEV = 1$  and can generate a protocol interrupt if  $PCR.DX2TIEN = 1$ .

**Universal Serial Interface Channel (USIC)**

**15.6.5 IIS Protocol Registers**

In IIS mode, the registers PCR and PSR handle IIS related information.

**15.6.5.1 IIS Protocol Control Registers**

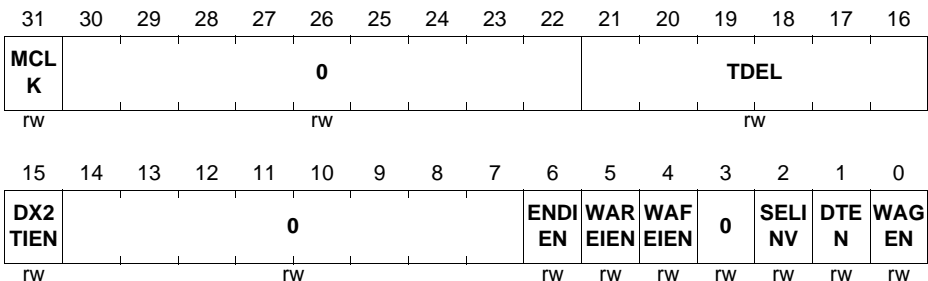
In IIS mode, the PCR register bits or bit fields are defined as described in this section.

**PCR**

**Protocol Control Register [IIS Mode]**

**(3C<sub>H</sub>)**

**Reset Value: 0000 0000<sub>H</sub>**



Field	Bits	Type	Description
<b>WAGEN</b>	0	rw	<p><b>WA Generation Enable</b></p> <p>This bit enables/disables the generation of word address control output signal WA.</p> <p>0<sub>B</sub> The IIS can be used as slave. The generation of the word address signal is disabled. The output signal WA is 0. The MCLKO signal generation depends on PCR.MCLK.</p> <p>1<sub>B</sub> The IIS can be used as master. The generation of the word address signal is enabled. The signal starts with a 0 after being enabled. The generation of MCLK is enabled, independent of PCR.MCLK. After clearing WAGEN, the USIC module stops the generation of the WA signal within the next 4 WA periods.</p>



**Universal Serial Interface Channel (USIC)**

<b>Field</b>	<b>Bits</b>	<b>Type</b>	<b>Description</b>
<b>DTEN</b>	1	rw	<p><b>Data Transfers Enable</b></p> <p>This bit enables/disables the transfer of IIS frames as a reaction to changes of the input word address control line WA.</p> <p>0<sub>B</sub> The changes of the WA input signal are ignored and no transfers take place.</p> <p>1<sub>B</sub> Transfers are enabled.</p>
<b>SELINV</b>	2	rw	<p><b>Select Inversion</b></p> <p>This bit defines if the polarity of the SELOx outputs in relation to the internally generated word address signal WA.</p> <p>0<sub>B</sub> The SELOx outputs have the same polarity as the WA signal.</p> <p>1<sub>B</sub> The SELOx outputs have the inverted polarity to the WA signal.</p>
<b>WAFEIEN</b>	4	rw	<p><b>WA Falling Edge Interrupt Enable</b></p> <p>This bit enables/disables the activation of a protocol interrupt when a falling edge of WA has been generated.</p> <p>0<sub>B</sub> A protocol interrupt is not activated if a falling edge of WA is generated.</p> <p>1<sub>B</sub> A protocol interrupt is activated if a falling edge of WA is generated.</p>
<b>WAREIEN</b>	5	rw	<p><b>WA Rising Edge Interrupt Enable</b></p> <p>This bit enables/disables the activation of a protocol interrupt when a rising edge of WA has been generated.</p> <p>0<sub>B</sub> A protocol interrupt is not activated if a rising edge of WA is generated.</p> <p>1<sub>B</sub> A protocol interrupt is activated if a rising edge of WA is generated.</p>
<b>ENDIEN</b>	6	rw	<p><b>END Interrupt Enable</b></p> <p>This bit enables/disables the activation of a protocol interrupt when the WA generation stops after clearing PCR.WAGEN (complete system word length is processed before stopping).</p> <p>0<sub>B</sub> A protocol interrupt is not activated.</p> <p>1<sub>B</sub> A protocol interrupt is activated.</p>

**Universal Serial Interface Channel (USIC)**

Field	Bits	Type	Description
<b>DX2TIEN</b>	15	rw	<b>DX2T Interrupt Enable</b> This bit enables/disables the generation of a protocol interrupt if the DX2T signal becomes activated (indicated by PSR.DX2TEV = 1). $0_B$ A protocol interrupt is not generated if DX2T is active. $1_B$ A protocol interrupt is generated if DX2T is active.
<b>TDEL</b>	[21:16]	rw	<b>Transfer Delay</b> This bit field defines the transfer delay when an event is detected. If bit field TDEL = 0, the additional delay functionality is switched off and a delay of one shift clock cycle is introduced.
<b>MCLK</b>	31	rw	<b>Master Clock Enable</b> This bit enables generation of the master clock MCLK (not directly used for IIC protocol, can be used as general frequency output). $0_B$ The MCLK generation is disabled and MCLK is 0. $1_B$ The MCLK generation is enabled.
<b>0</b>	3, [14:7], [30:22]	rw	<b>Reserved</b> Returns 0 if read; should be written with 0;

### 15.6.5.2 IIS Protocol Status Register

The following PSR status bits or bit fields are available in IIS mode. Please note that the bits in register PSR are not cleared by hardware.

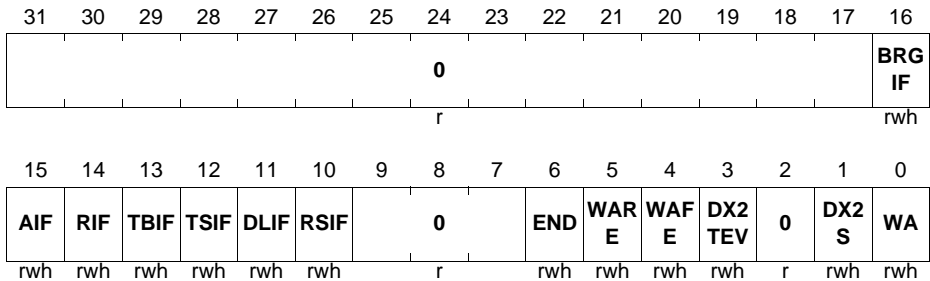
The flags in the PSR register can be cleared by writing a 1 to the corresponding bit position in register PSCR. Writing a 1 to a bit position in PSR sets the corresponding flag, but does not lead to further actions (no interrupt generation). Writing a 0 has no effect. These flags should be cleared by software before enabling a new protocol.

**Universal Serial Interface Channel (USIC)**

**PSR**

**Protocol Status Register [IIS Mode] (48<sub>H</sub>)**

**Reset Value: 0000 0000<sub>H</sub>**



Field	Bits	Type	Description
<b>WA</b>	0	rwh	<p><b>Word Address</b></p> <p>This bit indicates the status of the WA input signal, sampled after a transition of WA has been detected. This information is forwarded to the corresponding bit position RBUFSR[9] to distinguish between data received for the right and the left channel.</p> <p>0<sub>B</sub> WA has been sampled 0. 1<sub>B</sub> WA has been sampled 1.</p>
<b>DX2S</b>	1	rwh	<p><b>DX2S Status</b></p> <p>This bit indicates the current status of the DX2S signal, which is used as word address signal WA.</p> <p>0<sub>B</sub> DX2S is 0. 1<sub>B</sub> DX2S is 1.</p>
<b>DX2TEV</b>	3	rwh	<p><b>DX2T Event Detected<sup>1)</sup></b></p> <p>This bit indicates that the DX2T signal has been activated. In IIS slave mode, an activation of DX2T generates a protocol interrupt if PCR.DX2TIEN = 1.</p> <p>0<sub>B</sub> The DX2T signal has not been activated. 1<sub>B</sub> The DX2T signal has been activated.</p>
<b>WAFE</b>	4	rwh	<p><b>WA Falling Edge Event<sup>1)</sup></b></p> <p>This bit indicates that a falling edge of the WA output signal has been generated. This event generates a protocol interrupt if PCR.WAFEIEN = 1.</p> <p>0<sub>B</sub> A WA falling edge has not been generated. 1<sub>B</sub> A WA falling edge has been generated.</p>

**Universal Serial Interface Channel (USIC)**

<b>Field</b>	<b>Bits</b>	<b>Type</b>	<b>Description</b>
<b>WARE</b>	5	rwh	<b>WA Rising Edge Event<sup>1)</sup></b> This bit indicates that a rising edge of the WA output signal has been generated. This event generates a protocol interrupt if PCR.WAREIEN = 1. 0 <sub>B</sub> A WA rising edge has not been generated. 1 <sub>B</sub> A WA rising edge has been generated.
<b>END</b>	6	rwh	<b>WA Generation End<sup>1)</sup></b> This bit indicates that the WA generation has ended after clearing PCR.WAGEN. This bit should be cleared by software before clearing WAGEN. 0 <sub>B</sub> The WA generation has not yet ended (if it is running and WAGEN has been cleared). 1 <sub>B</sub> The WA generation has ended (if it has been running).
<b>RSIF</b>	10	rwh	<b>Receiver Start Indication Flag</b> 0 <sub>B</sub> A receiver start event has not occurred. 1 <sub>B</sub> A receiver start event has occurred.
<b>DLIF</b>	11	rwh	<b>Data Lost Indication Flag</b> 0 <sub>B</sub> A data lost event has not occurred. 1 <sub>B</sub> A data lost event has occurred.
<b>TSIF</b>	12	rwh	<b>Transmit Shift Indication Flag</b> 0 <sub>B</sub> A transmit shift event has not occurred. 1 <sub>B</sub> A transmit shift event has occurred.
<b>TBIF</b>	13	rwh	<b>Transmit Buffer Indication Flag</b> 0 <sub>B</sub> A transmit buffer event has not occurred. 1 <sub>B</sub> A transmit buffer event has occurred.
<b>RIF</b>	14	rwh	<b>Receive Indication Flag</b> 0 <sub>B</sub> A receive event has not occurred. 1 <sub>B</sub> A receive event has occurred.
<b>AIF</b>	15	rwh	<b>Alternative Receive Indication Flag</b> 0 <sub>B</sub> An alternative receive event has not occurred. 1 <sub>B</sub> An alternative receive event has occurred.
<b>BRGIF</b>	16	rwh	<b>Baud Rate Generator Indication Flag</b> 0 <sub>B</sub> A baud rate generator event has not occurred. 1 <sub>B</sub> A baud rate generator event has occurred.
<b>0</b>	2, [9:7], [31:17]	r	<b>Reserved</b> Returns 0 if read; not modified in IIS mode.

---

**Universal Serial Interface Channel (USIC)**

- 1) This status bit can generate a protocol interrupt (see [Page 15-21](#)). The general interrupt status flags are described in the general interrupt chapter.

## 15.7 Service Request Generation

The USIC module provides 6 service request outputs SR[5:0] to be shared between two channels. The service request outputs SR[5:0] are connected to interrupt nodes in the Nested Vectored Interrupt Controller (NVIC).

Each USIC communication channel can be connected to up to 6 service request handlers (connected to USICx.SR[5:0], though 3 or 4 are normally used, e.g. one for transmission, one for reception, one or two for protocol or error handling, or for the alternative receive events).

## 15.8 Debug Behaviour

Each USIC communication channel can be pre-configured to enter one of four kernel modes, when the program execution of the CPU is halted by the debugger.

Refer to [Section 15.2.2.2](#) for details.

## 15.9 Power, Reset and Clock

The USIC module is located in the core power domain. The module can be reset to its default state by a system reset.

The USIC module is clocked by the main clock, MCLK, from SCU. MCLK is disabled by default and can be enabled via the SCU\_CGATCLR0 register. Enabling and disabling the module clock could cause a load change and clock blanking could occur as described in the CCU (Clock Gating Control) section of the SCU chapter. It is strongly recommended to set up the module clock in the user initialization code to avoid clock blanking during runtime.

*Note: To differentiate from the USIC baud rate generator output, master clock (MCLK), the SCU MCLK is referenced throughout the USIC chapter as  $f_{PB}$ .*

## 15.10 Initialization and System Dependencies

The application has to apply the following initialization sequence before operating the USIC module:

- Enable the module by writing 1s to the MODEN and BPMODEN bits in KSCFG register.

## 15.11 Registers

**Table 15-19** shows all registers which are required for programming a USIC channel, as well as the FIFO buffer. It summarizes the USIC communication channel registers and defines the relative addresses and the reset values.

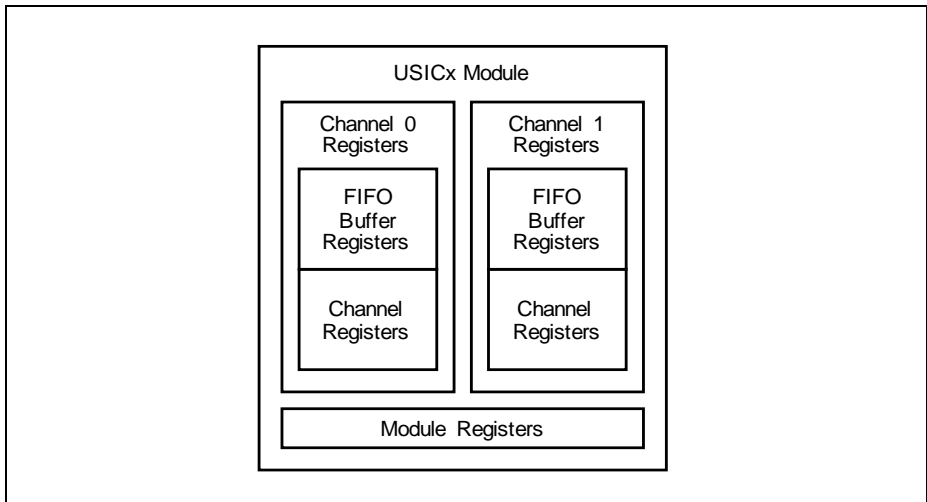
Please note that all registers can be accessed with any access width (8-bit, 16-bit, 32-bit), independent of the described width.

**Universal Serial Interface Channel (USIC)**

All USIC registers (except bit field KSCFG.SUMCFG) are always reset by a system reset. Bit field KSCFG.SUMCFG is reset by a debug reset.

*Note: The register bits marked “w” always deliver 0 when read. They are used to modify flip-flops in other registers or to trigger internal actions.*

**Figure 15-65** shows the register types of the USIC module registers and channel registers. In a specific microcontroller, module registers of USIC module “x” are marked by the module prefix “USICx\_”. Channel registers of USIC module “x” are marked by the channel prefix “USICx\_CH0\_” and “USICx\_CH1\_”.



**Figure 15-65 USIC Module and Channel Registers**

**Table 15-19 USIC Kernel-Related and Kernel Registers**

Register Short Name	Register Long Name	Offset Addr.	Access Mode		Description see
			Read	Write	
<b>Module Registers<sup>1)</sup></b>					
ID	Module Identification Register	008 <sub>H</sub>	U, PV	U, PV	<a href="#">Page 15-158</a>
<b>Channel Registers</b>					
–	reserved	000 <sub>H</sub>	BE	BE	–
CCFG	Channel Configuration Register	004 <sub>H</sub>	U, PV	U, PV	<a href="#">Page 15-163</a>
KSCFG	Kernel State Configuration Register	00C <sub>H</sub>	U, PV	U, PV	<a href="#">Page 15-164</a>
FDR	Fractional Divider Register	010 <sub>H</sub>	U, PV	PV	<a href="#">Page 15-177</a>

**Universal Serial Interface Channel (USIC)**

**Table 15-19 USIC Kernel-Related and Kernel Registers (cont'd)**

Register Short Name	Register Long Name	Offset Addr.	Access Mode		Description see
			Read	Write	
BRG	Baud Rate Generator Register	014 <sub>H</sub>	U, PV	PV	<a href="#">Page 15-178</a>
INPR	Interrupt Node Pointer Register	018 <sub>H</sub>	U, PV	U, PV	<a href="#">Page 15-167</a>
DX0CR	Input Control Register 0	01C <sub>H</sub>	U, PV	U, PV	<a href="#">Page 15-172</a>
DX1CR	Input Control Register 1	020 <sub>H</sub>	U, PV	U, PV	<a href="#">Page 15-174</a>
DX2CR	Input Control Register 2	024 <sub>H</sub>	U, PV	U, PV	<a href="#">Page 15-172</a>
DX3CR	Input Control Register 3	028 <sub>H</sub>	U, PV	U, PV	
DX4CR	Input Control Register 4	02C <sub>H</sub>	U, PV	U, PV	
DX5CR	Input Control Register 5	030 <sub>H</sub>	U, PV	U, PV	
SCTR	Shift Control Register	034 <sub>H</sub>	U, PV	U, PV	<a href="#">Page 15-182</a>
TCSR	Transmit Control/Status Register	038 <sub>H</sub>	U, PV	U, PV	<a href="#">Page 15-185</a>
PCR	Protocol Control Register	03C <sub>H</sub>	U, PV	U, PV	<a href="#">Page 15-168</a> <sup>2)</sup>
			U, PV	U, PV	<a href="#">Page 15-65</a> <sup>3)</sup>
			U, PV	U, PV	<a href="#">Page 15-97</a> <sup>4)</sup>
			U, PV	U, PV	<a href="#">Page 15-128</a> <sup>5)</sup>
			U, PV	U, PV	<a href="#">Page 15-147</a> <sup>6)</sup>
CCR	Channel Control Register	040 <sub>H</sub>	U, PV	PV	<a href="#">Page 15-159</a>
CMTR	Capture Mode Timer Register	044 <sub>H</sub>	U, PV	U, PV	<a href="#">Page 15-181</a>
PSR	Protocol Status Register	048 <sub>H</sub>	U, PV	U, PV	<a href="#">Page 15-169</a> <sup>2)</sup>
			U, PV	U, PV	<a href="#">Page 15-69</a> <sup>3)</sup>
			U, PV	U, PV	<a href="#">Page 15-101</a> <sup>4)</sup>
			U, PV	U, PV	<a href="#">Page 15-131</a> <sup>5)</sup>
			U, PV	U, PV	<a href="#">Page 15-150</a> <sup>6)</sup>
PSCR	Protocol Status Clear Register	04C <sub>H</sub>	U, PV	U, PV	<a href="#">Page 15-170</a>



**Universal Serial Interface Channel (USIC)**

**Table 15-19 USIC Kernel-Related and Kernel Registers (cont'd)**

Register Short Name	Register Long Name	Offset Addr.	Access Mode		Description see
			Read	Write	
RBUFSR	Receiver Buffer Status Register	050 <sub>H</sub>	U, PV	U, PV	<a href="#">Page 15-203</a>
RBUF	Receiver Buffer Register	054 <sub>H</sub>	U, PV	U, PV	<a href="#">Page 15-201</a>
RBUFD	Receiver Buffer Register for Debugger	058 <sub>H</sub>	U, PV	U, PV	<a href="#">Page 15-202</a>
RBUF0	Receiver Buffer Register 0	05C <sub>H</sub>	U, PV	U, PV	<a href="#">Page 15-194</a>
RBUF1	Receiver Buffer Register 1	060 <sub>H</sub>	U, PV	U, PV	<a href="#">Page 15-195</a>
RBUF01SR	Receiver Buffer 01 Status Register	064 <sub>H</sub>	U, PV	U, PV	<a href="#">Page 15-196</a>
FMR	Flag Modification Register	068 <sub>H</sub>	U, PV	U, PV	<a href="#">Page 15-192</a>
–	reserved; do not access this location	06C <sub>H</sub>	U, PV	BE	–
–	reserved	070 <sub>H</sub> - 07C <sub>H</sub>	BE	BE	–
TBUFx	Transmit Buffer Input Location x (x = 00-31)	080 <sub>H</sub> + x*4	U, PV	U, PV	<a href="#">Page 15-194</a>
<b>FIFO Buffer Registers</b>					
BYP	Bypass Data Register	100 <sub>H</sub>	U, PV	U, PV	<a href="#">Page 15-204</a>
BYPCTR	Bypass Control Register	104 <sub>H</sub>	U, PV	U, PV	<a href="#">Page 15-205</a>
TBCTR	Transmit Buffer Control Register	108 <sub>H</sub>	U, PV	U, PV	<a href="#">Page 15-213</a>
RBCTR	Receive Buffer Control Register	10C <sub>H</sub>	U, PV	U, PV	<a href="#">Page 15-217</a>
TRBPTR	Transmit/Receive Buffer Pointer Register	110 <sub>H</sub>	U, PV	U, PV	<a href="#">Page 15-225</a>
TRBSR	Transmit/Receive Buffer Status Register	114 <sub>H</sub>	U, PV	U, PV	<a href="#">Page 15-208</a>
TRBSCR	Transmit/Receive Buffer Status Clear Register	118 <sub>H</sub>	U, PV	U, PV	<a href="#">Page 15-212</a>
OUTR	Receive Buffer Output Register	11C <sub>H</sub>	U, PV	U, PV	<a href="#">Page 15-223</a>
OUTDR	Receive Buffer Output Register for Debugger	120 <sub>H</sub>	U, PV	U, PV	<a href="#">Page 15-224</a>

**Universal Serial Interface Channel (USIC)**

**Table 15-19 USIC Kernel-Related and Kernel Registers (cont'd)**

Register Short Name	Register Long Name	Offset Addr.	Access Mode		Description see
			Read	Write	
–	reserved	124 <sub>H</sub> - 17C <sub>H</sub>	BE	BE	–
INx	Transmit FIFO Buffer Input Location x (x = 00-31)	180 <sub>H</sub> + x*4	U, PV	U, PV	<a href="#">Page 15-222</a>

- 1) Details of the module identification registers are described in the implementation section (see [Page 15-158](#)).
- 2) This page shows the general register layout.
- 3) This page shows the register layout in ASC mode.
- 4) This page shows the register layout in SSC mode.
- 5) This page shows the register layout in IIC mode.
- 6) This page shows the register layout in IIS mode.

### 15.11.1 Address Map

The registers of the USIC communication channel are available at the following base addresses. The exact register address is given by the relative address of the register (given in [Table 15-19](#)) plus the channel base address (given in [Table 15-20](#)).

**Table 15-20 Registers Address Space**

Module	Base Address	End Address	Note
USIC0_CH0	48000000 <sub>H</sub>	480001FF <sub>H</sub>	–
USIC0_CH1	48000200 <sub>H</sub>	480003FF <sub>H</sub>	–

**Table 15-21 FIFO and Reserved Address Space**

Module	Base Address	End Address	Access Mode		Note
			Read	Write	
USIC0	48000400 <sub>H</sub>	480007FF <sub>H</sub>	nBE	nBE if in direct RAM test mode; otherwise BE	USIC0 RAM area, shared between USIC0_CH0 and USIC0_CH1
reserved	48000800 <sub>H</sub>	4800FFFF <sub>H</sub>	BE	BE	–

### 15.11.2 Module Identification Registers

The module identification registers indicate the function and the design step of the USIC modules.

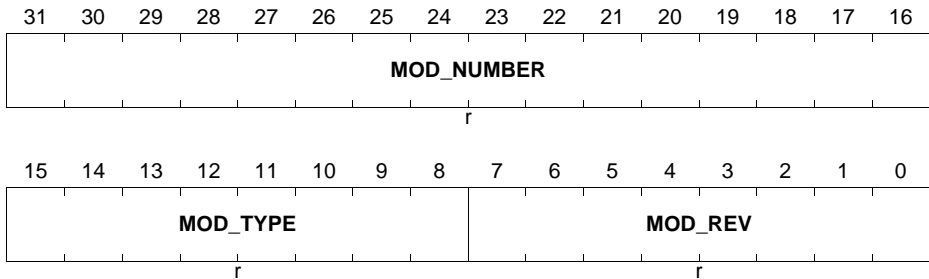
**Universal Serial Interface Channel (USIC)**

**USIC0\_ID**

**Module Identification Register**

(4800 0008<sub>H</sub>)

Reset Value: 00AA C0XX<sub>H</sub>



Field	Bits	Type	Description
<b>MOD_REV</b>	[7:0]	r	<b>Module Revision Number</b> MOD_REV defines the revision number. The value of a module revision starts with 01 <sub>H</sub> (first revision).
<b>MOD_TYPE</b>	[15:8]	r	<b>Module Type</b> This bit field is C0 <sub>H</sub> . It defines the module as a 32-bit module.
<b>MOD_NUMBER</b>	[31:16]	r	<b>Module Number Value</b> This bit field defines the USIC module identification number (00AA <sub>H</sub> = USIC).

### 15.11.3 Channel Control and Configuration Registers

#### 15.11.3.1 Channel Control Register

The channel control register contains the enable/disable bits for hardware port control and interrupt generation on channel events, the control of the parity generation and the protocol selection of a USIC channel.

FDR can be written only with a privilege mode access.

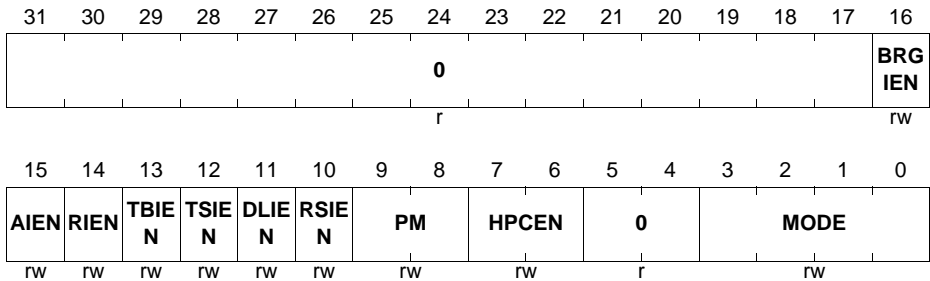
**Universal Serial Interface Channel (USIC)**

**CCR**

**Channel Control Register**

**(40<sub>H</sub>)**

**Reset Value: 0000 0000<sub>H</sub>**



Field	Bits	Type	Description
<b>MODE</b>	[3:0]	rw	<p><b>Operating Mode</b></p> <p>This bit field selects the protocol for this USIC channel. Selecting a protocol that is not available (see register CCFG) or a reserved combination disables the USIC channel. When switching between two protocols, the USIC channel has to be disabled before selecting a new protocol. In this case, registers PCR and PSR have to be cleared or updated by software.</p> <p>0<sub>H</sub> The USIC channel is disabled. All protocol-related state machines are set to an idle state.</p> <p>1<sub>H</sub> The SSC (SPI) protocol is selected.</p> <p>2<sub>H</sub> The ASC (SCI, UART) protocol is selected.</p> <p>3<sub>H</sub> The IIS protocol is selected.</p> <p>4<sub>H</sub> The IIC protocol is selected.</p> <p>Other bit combinations are reserved.</p>

**Universal Serial Interface Channel (USIC)**

Field	Bits	Type	Description
<b>HPCEN</b>	[7:6]	rw	<p><b>Hardware Port Control Enable</b></p> <p>This bit enables the hardware port control for the specified set of DX[3:0] and DOUT[3:0] pins.</p> <p>00<sub>B</sub> The hardware port control is disabled.</p> <p>01<sub>B</sub> The hardware port control is enabled for DX0 and DOUT0.</p> <p>10<sub>B</sub> The hardware port control is enabled for DX3, DX0 and DOUT[1:0].</p> <p>11<sub>B</sub> The hardware port control is enabled for DX0, DX[5:3] and DOUT[3:0].</p> <p><i>Note: The hardware port control feature is useful only for SSC protocols in half-duplex configurations, such as dual- and quad-SSC. For all other protocols HPCEN must always be written with 00<sub>B</sub>.</i></p>
<b>PM</b>	[9:8]	rw	<p><b>Parity Mode</b></p> <p>This bit field defines the parity generation of the sampled input values.</p> <p>00<sub>B</sub> The parity generation is disabled.</p> <p>01<sub>B</sub> Reserved</p> <p>10<sub>B</sub> Even parity is selected (parity bit = 1 on odd number of 1s in data, parity bit = 0 on even number of 1s in data).</p> <p>11<sub>B</sub> Odd parity is selected (parity bit = 0 on odd number of 1s in data, parity bit = 1 on even number of 1s in data).</p>
<b>RSIEN</b>	10	rw	<p><b>Receiver Start Interrupt Enable</b></p> <p>This bit enables the interrupt generation in case of a receiver start event.</p> <p>0<sub>B</sub> The receiver start interrupt is disabled.</p> <p>1<sub>B</sub> The receiver start interrupt is enabled.</p> <p>In case of a receiver start event, the service request output SRx indicated by INPR.TBINP is activated.</p>

**Universal Serial Interface Channel (USIC)**

<b>Field</b>	<b>Bits</b>	<b>Type</b>	<b>Description</b>
<b>DLIEN</b>	11	rw	<p><b>Data Lost Interrupt Enable</b> This bit enables the interrupt generation in case of a data lost event (data received in RBUFx while RDVx = 1).</p> <p>0<sub>B</sub> The data lost interrupt is disabled. 1<sub>B</sub> The data lost interrupt is enabled. In case of a data lost event, the service request output SRx indicated by INPR.PINP is activated.</p>
<b>TSIEN</b>	12	rw	<p><b>Transmit Shift Interrupt Enable</b> This bit enables the interrupt generation in case of a transmit shift event.</p> <p>0<sub>B</sub> The transmit shift interrupt is disabled. 1<sub>B</sub> The transmit shift interrupt is enabled. In case of a transmit shift interrupt event, the service request output SRx indicated by INPR.TSINP is activated.</p>
<b>TBIEN</b>	13	rw	<p><b>Transmit Buffer Interrupt Enable</b> This bit enables the interrupt generation in case of a transmit buffer event.</p> <p>0<sub>B</sub> The transmit buffer interrupt is disabled. 1<sub>B</sub> The transmit buffer interrupt is enabled. In case of a transmit buffer event, the service request output SRx indicated by INPR.TBINP is activated.</p>
<b>RIEN</b>	14	rw	<p><b>Receive Interrupt Enable</b> This bit enables the interrupt generation in case of a receive event.</p> <p>0<sub>B</sub> The receive interrupt is disabled. 1<sub>B</sub> The receive interrupt is enabled. In case of a receive event, the service request output SRx indicated by INPR.RINP is activated.</p>
<b>AIEN</b>	15	rw	<p><b>Alternative Receive Interrupt Enable</b> This bit enables the interrupt generation in case of an alternative receive event.</p> <p>0<sub>B</sub> The alternative receive interrupt is disabled. 1<sub>B</sub> The alternative receive interrupt is enabled. In case of an alternative receive event, the service request output SRx indicated by INPR.AINP is activated.</p>

**Universal Serial Interface Channel (USIC)**

<b>Field</b>	<b>Bits</b>	<b>Type</b>	<b>Description</b>
<b>BRGIEN</b>	16	rw	<p><b>Baud Rate Generator Interrupt Enable</b></p> <p>This bit enables the interrupt generation in case of a baud rate generator event.</p> <p>0<sub>B</sub> The baud rate generator interrupt is disabled.</p> <p>1<sub>B</sub> The baud rate generator interrupt is enabled. In case of a baud rate generator event, the service request output SRx indicated by INPR.PINP is activated.</p>
<b>0</b>	[5:4], [31:17]	r	<p><b>Reserved</b></p> <p>Read as 0; should be written with 0.</p>

**Universal Serial Interface Channel (USIC)**

**15.11.3.2 Channel Configuration Register**

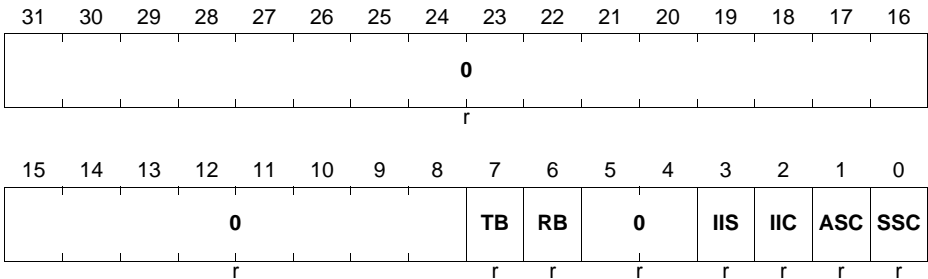
The channel configuration register contains indicates the functionality that is available in the USIC channel.

**CCFG**

**Channel Configuration Register**

**(04<sub>H</sub>)**

**Reset Value: 0000 00CF<sub>H</sub>**



Field	Bits	Type	Description
<b>SSC</b>	0	r	<b>SSC Protocol Available</b> This bit indicates if the SSC protocol is available. 0 <sub>B</sub> The SSC protocol is not available. 1 <sub>B</sub> The SSC protocol is available.
<b>ASC</b>	1	r	<b>ASC Protocol Available</b> This bit indicates if the ASC protocol is available. 0 <sub>B</sub> The ASC protocol is not available. 1 <sub>B</sub> The ASC protocol is available.
<b>IIC</b>	2	r	<b>IIC Protocol Available</b> This bit indicates if the IIC functionality is available. 0 <sub>B</sub> The IIC protocol is not available. 1 <sub>B</sub> The IIC protocol is available.
<b>IIS</b>	3	r	<b>IIS Protocol Available</b> This bit indicates if the IIS protocol is available. 0 <sub>B</sub> The IIS protocol is not available. 1 <sub>B</sub> The IIS protocol is available.
<b>RB</b>	6	r	<b>Receive FIFO Buffer Available</b> This bit indicates if an additional receive FIFO buffer is available. 0 <sub>B</sub> A receive FIFO buffer is not available. 1 <sub>B</sub> A receive FIFO buffer is available.



**Universal Serial Interface Channel (USIC)**

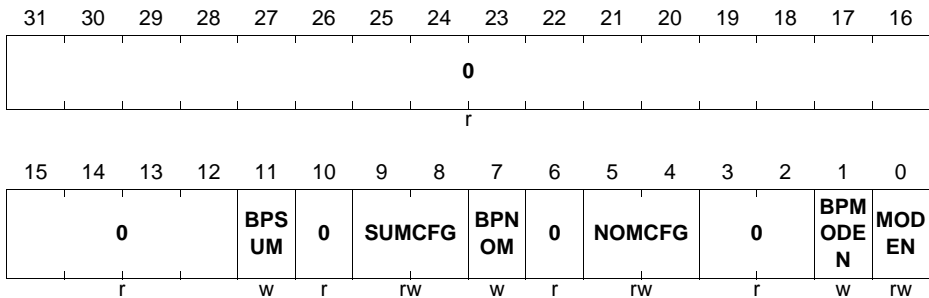
Field	Bits	Type	Description
<b>TB</b>	7	r	<b>Transmit FIFO Buffer Available</b> This bit indicates if an additional transmit FIFO buffer is available. 0 <sub>B</sub> A transmit FIFO buffer is not available. 1 <sub>B</sub> A transmit FIFO buffer is available.
<b>0</b>	[5:4], [15:8], [31:16]	r	<b>Reserved</b> Read as 0; should be written with 0.

### 15.11.3.3 Kernel State Configuration Register

The kernel state configuration register KSCFG allows the selection of the desired kernel modes for the different device operating modes.

#### KSCFG

**Kernel State Configuration Register (0C<sub>H</sub>)** **Reset Value: 0000 0000<sub>H</sub>**



**Universal Serial Interface Channel (USIC)**

Field	Bits	Type	Description
<b>MODEN</b>	0	rw	<p><b>Module Enable</b></p> <p>This bit enables the module kernel clock and the module functionality.</p> <p>0<sub>B</sub> The module is switched off immediately (without respecting a stop condition). It does not react on mode control actions and the module clock is switched off. The module does not react on read accesses and ignores write accesses (except to KSCFG).</p> <p>1<sub>B</sub> The module is switched on and can operate. After writing 1 to MODEN, it is recommended to read register KSCFG to avoid pipeline effects in the control block before accessing other USIC registers.</p>
<b>BPMODEN</b>	1	w	<p><b>Bit Protection for MODEN</b></p> <p>This bit enables the write access to the bit MODEN. It always reads 0.</p> <p>0<sub>B</sub> MODEN is not changed.</p> <p>1<sub>B</sub> MODEN is updated with the written value.</p>
<b>NOMCFG</b>	[5:4]	rw	<p><b>Normal Operation Mode Configuration</b></p> <p>This bit field defines the kernel mode applied in normal operation mode.</p> <p>00<sub>B</sub> Run mode 0 is selected.</p> <p>01<sub>B</sub> Run mode 1 is selected.</p> <p>10<sub>B</sub> Stop mode 0 is selected.</p> <p>11<sub>B</sub> Stop mode 1 is selected.</p>
<b>BPNOM</b>	7	w	<p><b>Bit Protection for NOMCFG</b></p> <p>This bit enables the write access to the bit field NOMCFG. It always reads 0.</p> <p>0<sub>B</sub> NOMCFG is not changed.</p> <p>1<sub>B</sub> NOMCFG is updated with the written value.</p>
<b>SUMCFG</b>	[9:8]	rw	<p><b>Suspend Mode Configuration</b></p> <p>This bit field defines the kernel mode applied in suspend mode. Coding like NOMCFG.</p>

**Universal Serial Interface Channel (USIC)**

Field	Bits	Type	Description
<b>BPSUM</b>	11	w	<b>Bit Protection for SUMCFG</b> This bit enables the write access to the bit field SUMCFG. It always reads 0. 0 <sub>B</sub> SUMCFG is not changed. 1 <sub>B</sub> SUMCFG is updated with the written value.
<b>0</b>	[3:2], 6, 10, [31:12]	r	<b>Reserved</b> Read as 0; should be written with 0. Bit 2 can read as 1 after BootROM exit (but can be ignored).

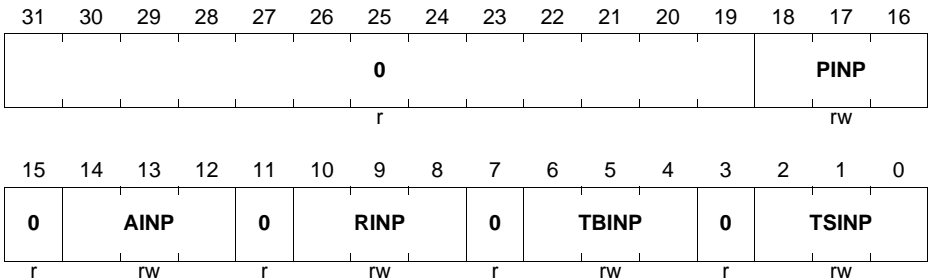
**Universal Serial Interface Channel (USIC)**

**15.11.3.4 Interrupt Node Pointer Register**

The interrupt node pointer register defines the service request output SRx that is activated if the corresponding event occurs and interrupt generation is enabled.

**INPR**

**Interrupt Node Pointer Register (18<sub>H</sub>)** **Reset Value: 0000 0000<sub>H</sub>**



Field	Bits	Type	Description
<b>TSINP</b>	[2:0]	rw	<p><b>Transmit Shift Interrupt Node Pointer</b></p> <p>This bit field defines which service request output SRx becomes activated in case of a transmit shift interrupt.</p> <p>000<sub>B</sub> Output SR0 becomes activated.            001<sub>B</sub> Output SR1 becomes activated.            010<sub>B</sub> Output SR2 becomes activated.            011<sub>B</sub> Output SR3 becomes activated.            100<sub>B</sub> Output SR4 becomes activated.            101<sub>B</sub> Output SR5 becomes activated.</p> <p><i>Note: All other settings of the bit field are reserved.</i></p>
<b>TBINP</b>	[6:4]	rw	<p><b>Transmit Buffer Interrupt Node Pointer</b></p> <p>This bit field defines which service request output SRx will be activated in case of a transmit buffer interrupt or a receive start interrupt. Coding like TSINP.</p>
<b>RINP</b>	[10:8]	rw	<p><b>Receive Interrupt Node Pointer</b></p> <p>This bit field defines which service request output SRx will be activated in case of a receive interrupt. Coding like TSINP.</p>

**Universal Serial Interface Channel (USIC)**

Field	Bits	Type	Description
<b>AINP</b>	[14:12]	rw	<b>Alternative Receive Interrupt Node Pointer</b> This bit field defines which service request output SRx will be activated in case of a alternative receive interrupt. Coding like TSINP.
<b>PINP</b>	[18:16]	rw	<b>Protocol Interrupt Node Pointer</b> This bit field defines which service request output SRx becomes activated in case of a protocol interrupt. Coding like TSINP.
<b>0</b>	3, 7, 11, 15, [31:19]	r	<b>Reserved</b> Read as 0; should be written with 0.

## 15.11.4 Protocol Related Registers

### 15.11.4.1 Protocol Control Registers

The bits in the protocol control register define protocol-specific functions. They have to be configured by software before enabling a new protocol. Only the bits used for the selected protocol are taken into account, whereas the other bit positions always read as 0. The protocol-specific meaning is described in the related protocol section.

#### PCR

**Protocol Control Register (3C<sub>H</sub>)**      **Reset Value: 0000 0000<sub>H</sub>**

31	30	29	28	27	26	25	24	23	22	21	20	19	18	17	16
<b>CTR 31</b>	<b>CTR 30</b>	<b>CTR 29</b>	<b>CTR 28</b>	<b>CTR 27</b>	<b>CTR 26</b>	<b>CTR 25</b>	<b>CTR 24</b>	<b>CTR 23</b>	<b>CTR 22</b>	<b>CTR 21</b>	<b>CTR 20</b>	<b>CTR 19</b>	<b>CTR 18</b>	<b>CTR 17</b>	<b>CTR 16</b>
rw	rw	rw	rw	rw	rw	rw	rw	rw	rw	rw	rw	rw	rw	rw	rw
15	14	13	12	11	10	9	8	7	6	5	4	3	2	1	0
<b>CTR 15</b>	<b>CTR 14</b>	<b>CTR 13</b>	<b>CTR 12</b>	<b>CTR 11</b>	<b>CTR 10</b>	<b>CTR 9</b>	<b>CTR 8</b>	<b>CTR 7</b>	<b>CTR 6</b>	<b>CTR 5</b>	<b>CTR 4</b>	<b>CTR 3</b>	<b>CTR 2</b>	<b>CTR 1</b>	<b>CTR 0</b>
rw	rw	rw	rw	rw	rw	rw	rw	rw	rw	rw	rw	rw	rw	rw	rw

Field	Bits	Type	Description
<b>CTR<sub>x</sub></b> <b>(x = 0-31)</b>	x	rw	<b>Protocol Control Bit x</b> This bit is a protocol control bit.

**Universal Serial Interface Channel (USIC)**

**15.11.4.2 Protocol Status Register**

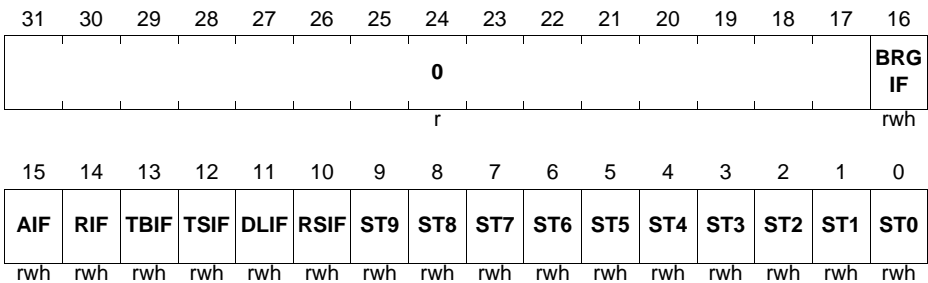
The flags in the protocol status register can be cleared by writing a 1 to the corresponding bit position in register PSCR. Writing a 1 to a bit position in PSR sets the corresponding flag, but does not lead to further actions (no interrupt generation). Writing a 0 has no effect. These flags should be cleared by software before enabling a new protocol. The protocol-specific meaning is described in the related protocol section.

**PSR**

**Protocol Status Register**

**(48<sub>H</sub>)**

**Reset Value: 0000 0000<sub>H</sub>**



Field	Bits	Type	Description
<b>STx</b> <b>(x = 0-9)</b>	x	rwh	<b>Protocol Status Flag x</b> See protocol specific description.
<b>RSIF</b>	10	rwh	<b>Receiver Start Indication Flag</b> 0 <sub>B</sub> A receiver start event has not occurred. 1 <sub>B</sub> A receiver start event has occurred.
<b>DLIF</b>	11	rwh	<b>Data Lost Indication Flag</b> 0 <sub>B</sub> A data lost event has not occurred. 1 <sub>B</sub> A data lost event has occurred.
<b>TSIF</b>	12	rwh	<b>Transmit Shift Indication Flag</b> 0 <sub>B</sub> A transmit shift event has not occurred. 1 <sub>B</sub> A transmit shift event has occurred.
<b>TBIF</b>	13	rwh	<b>Transmit Buffer Indication Flag</b> 0 <sub>B</sub> A transmit buffer event has not occurred. 1 <sub>B</sub> A transmit buffer event has occurred.
<b>RIF</b>	14	rwh	<b>Receive Indication Flag</b> 0 <sub>B</sub> A receive event has not occurred. 1 <sub>B</sub> A receive event has occurred.

**Universal Serial Interface Channel (USIC)**

Field	Bits	Type	Description
<b>AIF</b>	15	rwh	<b>Alternative Receive Indication Flag</b> $0_B$ An alternative receive event has not occurred. $1_B$ An alternative receive event has occurred.
<b>BRGIF</b>	16	rwh	<b>Baud Rate Generator Indication Flag</b> $0_B$ A baud rate generator event has not occurred. $1_B$ A baud rate generator event has occurred.
<b>0</b>	[31:17]	r	<b>Reserved;</b> read as 0; should be written with 0;

### 15.11.4.3 Protocol Status Clear Register

Read accesses to this register always deliver 0 at all bit positions.

#### PSCR

**Protocol Status Clear Register (4C<sub>H</sub>)** **Reset Value: 0000 0000<sub>H</sub>**

31	30	29	28	27	26	25	24	23	22	21	20	19	18	17	16
0															<b>CBR GIF</b>
															w

15	14	13	12	11	10	9	8	7	6	5	4	3	2	1	0
<b>CAIF</b>	<b>CRIF</b>	<b>CTBI</b>	<b>CTSI</b>	<b>CDLI</b>	<b>CRSI</b>	<b>CST</b>	<b>CST</b>	<b>CST</b>	<b>CST</b>	<b>CST</b>	<b>CST</b>	<b>CST</b>	<b>CST</b>	<b>CST</b>	<b>CST</b>
F	F	F	F	F	F	9	8	7	6	5	4	3	2	1	0
w	w	w	w	w	w	w	w	w	w	w	w	w	w	w	w

Field	Bits	Type	Description
<b>CSTx</b> <b>(x = 0-9)</b>	x	w	<b>Clear Status Flag x in PSR</b> $0_B$ No action $1_B$ Flag PSR.STx is cleared.
<b>CRSIF</b>	10	w	<b>Clear Receiver Start Indication Flag</b> $0_B$ No action $1_B$ Flag PSR.RSIF is cleared.
<b>CDLIF</b>	11	w	<b>Clear Data Lost Indication Flag</b> $0_B$ No action $1_B$ Flag PSR.DLIF is cleared.

**Universal Serial Interface Channel (USIC)**

Field	Bits	Type	Description
<b>CTSIF</b>	12	w	<b>Clear Transmit Shift Indication Flag</b> 0 <sub>B</sub> No action 1 <sub>B</sub> Flag PSR.TSIF is cleared.
<b>CTBIF</b>	13	w	<b>Clear Transmit Buffer Indication Flag</b> 0 <sub>B</sub> No action 1 <sub>B</sub> Flag PSR.TBIF is cleared.
<b>CRIF</b>	14	w	<b>Clear Receive Indication Flag</b> 0 <sub>B</sub> No action 1 <sub>B</sub> Flag PSR.RIF is cleared.
<b>CAIF</b>	15	w	<b>Clear Alternative Receive Indication Flag</b> 0 <sub>B</sub> No action 1 <sub>B</sub> Flag PSR.AIF is cleared.
<b>CBRGIF</b>	16	w	<b>Clear Baud Rate Generator Indication Flag</b> 0 <sub>B</sub> No action 1 <sub>B</sub> Flag PSR.BRGIF is cleared.
<b>0</b>	[31:17]	r	<b>Reserved;</b> read as 0; should be written with 0;

## 15.11.5 Input Stage Register

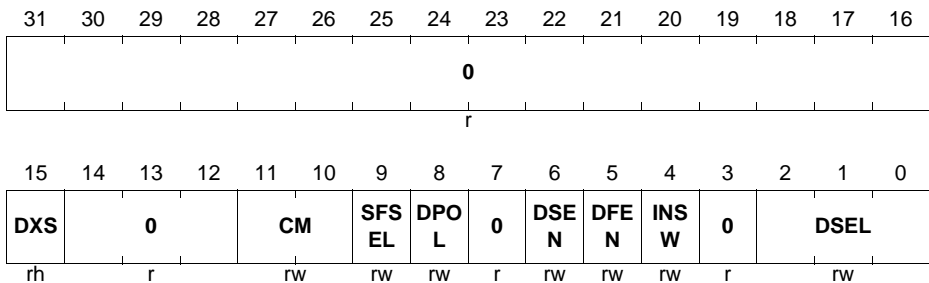
### 15.11.5.1 Input Control Registers

The input control registers contain the bits to define the characteristics of the input stages (input stage DX0 is controlled by register DX0CR, etc.).



**Universal Serial Interface Channel (USIC)**

<b>DX0CR</b>		
<b>Input Control Register 0</b>	<b>(1C<sub>H</sub>)</b>	<b>Reset Value: 0000 0000<sub>H</sub></b>
<b>DX2CR</b>		
<b>Input Control Register 2</b>	<b>(24<sub>H</sub>)</b>	<b>Reset Value: 0000 0000<sub>H</sub></b>
<b>DX3CR</b>		
<b>Input Control Register 3</b>	<b>(28<sub>H</sub>)</b>	<b>Reset Value: 0000 0000<sub>H</sub></b>
<b>DX4CR</b>		
<b>Input Control Register 4</b>	<b>(2C<sub>H</sub>)</b>	<b>Reset Value: 0000 0000<sub>H</sub></b>
<b>DX5CR</b>		
<b>Input Control Register 5</b>	<b>(30<sub>H</sub>)</b>	<b>Reset Value: 0000 0000<sub>H</sub></b>



Field	Bits	Type	Description
<b>DSEL</b>	[2:0]	rw	<p><b>Data Selection for Input Signal</b></p> <p>This bit field defines the input data signal for the corresponding input line for protocol pre-processor. The selection can be made from the input vector DXn[G:A].</p> <p>000<sub>B</sub> The data input DXnA is selected.            001<sub>B</sub> The data input DXnB is selected.            010<sub>B</sub> The data input DXnC is selected.            011<sub>B</sub> The data input DXnD is selected.            100<sub>B</sub> The data input DXnE is selected.            101<sub>B</sub> The data input DXnF is selected.            110<sub>B</sub> The data input DXnG is selected.            111<sub>B</sub> The data input is always 1.</p>

**Universal Serial Interface Channel (USIC)**

Field	Bits	Type	Description
<b>INSW</b>	4	rw	<p><b>Input Switch</b></p> <p>This bit defines if the data shift unit input is derived from the input data path DXn or from the selected protocol pre-processors.</p> <p>0<sub>B</sub> The input of the data shift unit is controlled by the protocol pre-processor.</p> <p>1<sub>B</sub> The input of the data shift unit is connected to the selected data input line. This setting is used if the signals are directly derived from an input pin without treatment by the protocol pre-processor.</p>
<b>DFEN</b>	5	rw	<p><b>Digital Filter Enable</b></p> <p>This bit enables/disables the digital filter for signal DXnS.</p> <p>0<sub>B</sub> The input signal is not digitally filtered.</p> <p>1<sub>B</sub> The input signal is digitally filtered.</p>
<b>DSEN</b>	6	rw	<p><b>Data Synchronization Enable</b></p> <p>This bit selects if the asynchronous input signal or the synchronized (and optionally filtered) signal DXnS can be used as input for the data shift unit.</p> <p>0<sub>B</sub> The un-synchronized signal can be taken as input for the data shift unit.</p> <p>1<sub>B</sub> The synchronized signal can be taken as input for the data shift unit.</p>
<b>DPOL</b>	8	rw	<p><b>Data Polarity for DXn</b></p> <p>This bit defines the signal polarity of the input signal.</p> <p>0<sub>B</sub> The input signal is not inverted.</p> <p>1<sub>B</sub> The input signal is inverted.</p>
<b>SFSEL</b>	9	rw	<p><b>Sampling Frequency Selection</b></p> <p>This bit defines the sampling frequency of the digital filter for the synchronized signal DXnS.</p> <p>0<sub>B</sub> The sampling frequency is <math>f_{PB}</math>.</p> <p>1<sub>B</sub> The sampling frequency is <math>f_{FD}</math>.</p>

**Universal Serial Interface Channel (USIC)**

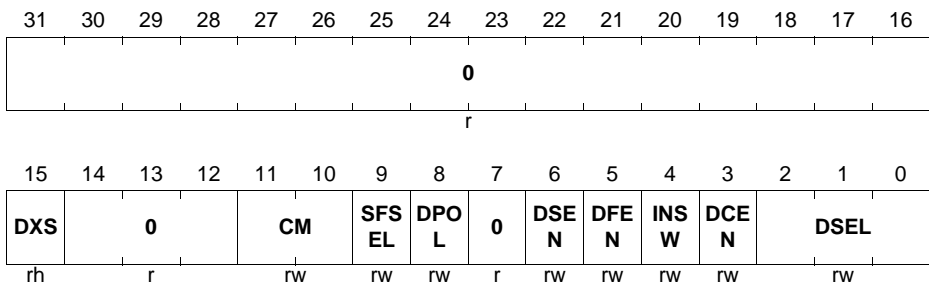
Field	Bits	Type	Description
<b>CM</b>	[11:10]	rw	<b>Combination Mode</b> This bit field selects which edge of the synchronized (and optionally filtered) signal DXnS activates the trigger output DXnT of the input stage. 00 <sub>B</sub> The trigger activation is disabled. 01 <sub>B</sub> A rising edge activates DXnT. 10 <sub>B</sub> A falling edge activates DXnT. 11 <sub>B</sub> Both edges activate DXnT.
<b>DXS</b>	15	rh	<b>Synchronized Data Value</b> This bit indicates the value of the synchronized (and optionally filtered) input signal. 0 <sub>B</sub> The current value of DXnS is 0. 1 <sub>B</sub> The current value of DXnS is 1.
<b>0</b>	3, 7, [14:12] , [31:16]	r	<b>Reserved</b> Read as 0; should be written with 0.

**DX1CR**

**Input Control Register 1**

(20<sub>H</sub>)

Reset Value: 0000 0000<sub>H</sub>



**Universal Serial Interface Channel (USIC)**

<b>Field</b>	<b>Bits</b>	<b>Type</b>	<b>Description</b>
<b>DSEL</b>	[2:0]	rw	<p><b>Data Selection for Input Signal</b></p> <p>This bit field defines the input data signal for the corresponding input line for protocol pre-processor. The selection can be made from the input vector DX1[G:A].</p> <p>000<sub>B</sub> The data input DX1A is selected.            001<sub>B</sub> The data input DX1B is selected.            010<sub>B</sub> The data input DX1C is selected.            011<sub>B</sub> The data input DX1D is selected.            100<sub>B</sub> The data input DX1E is selected.            101<sub>B</sub> The data input DX1F is selected.            110<sub>B</sub> The data input DX1G is selected.            111<sub>B</sub> The data input is always 1.</p>
<b>DCEN</b>	3	rw	<p><b>Delay Compensation Enable</b></p> <p>This bit selects if the receive shift clock is controlled by INSW or derived from the input data path DX1.</p> <p>0<sub>B</sub> The receive shift clock is dependent on INSW selection.            1<sub>B</sub> The receive shift clock is connected to the selected data input line. This setting is used if delay compensation is required in SSC and IIS protocols, else DCEN should always be 0.</p>
<b>INSW</b>	4	rw	<p><b>Input Switch</b></p> <p>This bit defines if the data shift unit input is derived from the input data path DX1 or from the selected protocol pre-processors.</p> <p>0<sub>B</sub> The input of the data shift unit is controlled by the protocol pre-processor.            1<sub>B</sub> The input of the data shift unit is connected to the selected data input line. This setting is used if the signals are directly derived from an input pin without treatment by the protocol pre-processor.</p>
<b>DFEN</b>	5	rw	<p><b>Digital Filter Enable</b></p> <p>This bit enables/disables the digital filter for signal DX1S.</p> <p>0<sub>B</sub> The input signal is not digitally filtered.            1<sub>B</sub> The input signal is digitally filtered.</p>

**Universal Serial Interface Channel (USIC)**

Field	Bits	Type	Description
<b>DSEN</b>	6	rw	<p><b>Data Synchronization Enable</b></p> <p>This bit selects if the asynchronous input signal or the synchronized (and optionally filtered) signal DX1S can be used as input for the data shift unit.</p> <p>0<sub>B</sub> The un-synchronized signal can be taken as input for the data shift unit.</p> <p>1<sub>B</sub> The synchronized signal can be taken as input for the data shift unit.</p>
<b>DPOL</b>	8	rw	<p><b>Data Polarity for DXn</b></p> <p>This bit defines the signal polarity of the input signal.</p> <p>0<sub>B</sub> The input signal is not inverted.</p> <p>1<sub>B</sub> The input signal is inverted.</p>
<b>SFSEL</b>	9	rw	<p><b>Sampling Frequency Selection</b></p> <p>This bit defines the sampling frequency of the digital filter for the synchronized signal DX1S.</p> <p>0<sub>B</sub> The sampling frequency is <math>f_{PB}</math>.</p> <p>1<sub>B</sub> The sampling frequency is <math>f_{FD}</math>.</p>
<b>CM</b>	[11:10]	rw	<p><b>Combination Mode</b></p> <p>This bit field selects which edge of the synchronized (and optionally filtered) signal DX1S activates the trigger output DX1T of the input stage.</p> <p>00<sub>B</sub> The trigger activation is disabled.</p> <p>01<sub>B</sub> A rising edge activates DX1T.</p> <p>10<sub>B</sub> A falling edge activates DX1T.</p> <p>11<sub>B</sub> Both edges activate DX1T.</p>
<b>DXS</b>	15	rh	<p><b>Synchronized Data Value</b></p> <p>This bit indicates the value of the synchronized (and optionally filtered) input signal.</p> <p>0<sub>B</sub> The current value of DX1S is 0.</p> <p>1<sub>B</sub> The current value of DX1S is 1.</p>
<b>0</b>	7, [14:12], , [31:16]	r	<p><b>Reserved</b></p> <p>Read as 0; should be written with 0.</p>

## 15.11.6 Baud Rate Generator Registers

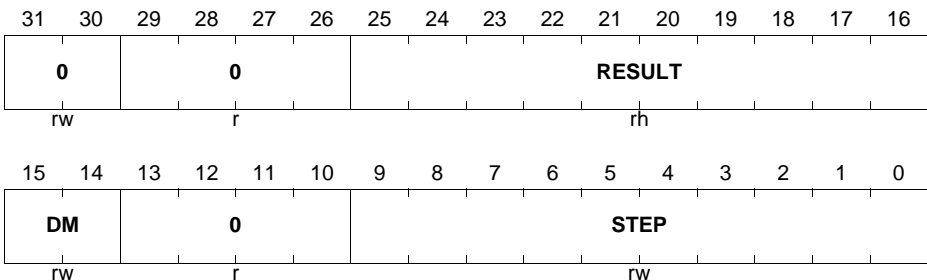
### 15.11.6.1 Fractional Divider Register

The fractional divider register FDR allows the generation of the internal frequency  $f_{FD}$ , that is derived from the system clock  $f_{PB}$ .

FDR can be written only with a privilege mode access.

#### FDR

**Fractional Divider Register (10<sub>H</sub>)**      **Reset Value: 0000 0000<sub>H</sub>**



Field	Bits	Type	Description
<b>STEP</b>	[9:0]	rw	<p><b>Step Value</b></p> <p>In normal divider mode STEP contains the reload value for RESULT after RESULT has reached 3FF<sub>H</sub>. In fractional divider mode STEP defines the value added to RESULT with each input clock cycle.</p>
<b>DM</b>	[15:14]	rw	<p><b>Divider Mode</b></p> <p>This bit fields defines the functionality of the fractional divider block.</p> <p>00<sub>B</sub> The divider is switched off, <math>f_{FD} = 0</math>.</p> <p>01<sub>B</sub> Normal divider mode selected.</p> <p>10<sub>B</sub> Fractional divider mode selected.</p> <p>11<sub>B</sub> The divider is switched off, <math>f_{FD} = 0</math>.</p>

**Universal Serial Interface Channel (USIC)**

Field	Bits	Type	Description
<b>RESULT</b>	[25:16]	rh	<b>Result Value</b> In normal divider mode this bit field is updated with $f_{PB}$ according to: $RESULT = RESULT + 1$ In fractional divider mode this bit field is updated with $f_{PB}$ according to: $RESULT = RESULT + STEP$ If bit field DM is written with $01_B$ or $10_B$ , RESULT is loaded with a start value of $3FF_H$ .
<b>0</b>	[31:30]	rw	<b>Reserved for Future Use</b> Must be written with 0 to allow correct fractional divider operation.
<b>0</b>	[13:10], [29:26]	r	<b>Reserved</b> Read as 0; should be written with 0.

### 15.11.6.2 Baud Rate Generator Register

The protocol-related counters for baud rate generation and timing measurement are controlled by the register BRG.

FDR can be written only with a privilege mode access.

#### BRG

**Baud Rate Generator Register (14<sub>H</sub>)**      **Reset Value: 0000 0000<sub>H</sub>**

31	30	29	28	27	26	25	24	23	22	21	20	19	18	17	16
<b>SCLKCFG</b>		<b>MCL KCF G</b>	<b>SCL KOS EL</b>	<b>0</b>		<b>PDIV</b>									
rw		rw	rw	r		rw									
15	14	13	12	11	10	9	8	7	6	5	4	3	2	1	0
<b>0</b>		<b>DCTQ</b>				<b>PCTQ</b>		<b>CTQSEL</b>		<b>0</b>	<b>PPP EN</b>	<b>TME N</b>	<b>0</b>	<b>CLKSEL</b>	
r		rw				rw		rw		r	rw	rw	r	rw	

**Universal Serial Interface Channel (USIC)**

Field	Bits	Type	Description
<b>CLKSEL</b>	[1:0]	rw	<p><b>Clock Selection</b></p> <p>This bit field defines the input frequency <math>f_{PIN}</math></p> <p>00<sub>B</sub> The fractional divider frequency <math>f_{FD}</math> is selected.</p> <p>01<sub>B</sub> Reserved, no action</p> <p>10<sub>B</sub> The trigger signal DX1T defines <math>f_{PIN}</math>. Signal MCLK toggles with <math>f_{PIN}</math>.</p> <p>11<sub>B</sub> Signal MCLK corresponds to the DX1S signal and the frequency <math>f_{PIN}</math> is derived from the rising edges of DX1S.</p>
<b>TMEN</b>	3	rw	<p><b>Timing Measurement Enable</b></p> <p>This bit enables the timing measurement of the capture mode timer.</p> <p>0<sub>B</sub> Timing measurement is disabled: The trigger signals DX0T and DX1T are ignored.</p> <p>1<sub>B</sub> Timing measurement is enabled: The 10-bit counter is incremented by 1 with <math>f_{PPP}</math> and stops counting when reaching its maximum value. If one of the trigger signals DX0T or DX1T become active, the counter value is captured into bit field CTV, the counter is cleared and a transmit shift event is generated.</p>
<b>PPPEN</b>	4	rw	<p><b>Enable 2:1 Divider for <math>f_{PPP}</math></b></p> <p>This bit defines the input frequency <math>f_{PPP}</math>.</p> <p>0<sub>B</sub> The 2:1 divider for <math>f_{PPP}</math> is disabled. <math>f_{PPP} = f_{PIN}</math></p> <p>1<sub>B</sub> The 2:1 divider for <math>f_{PPP}</math> is enabled. <math>f_{PPP} = f_{MCLK} = f_{PIN} / 2</math>.</p>
<b>CTQSEL</b>	[7:6]	rw	<p><b>Input Selection for CTQ</b></p> <p>This bit defines the length of a time quantum for the protocol pre-processor.</p> <p>00<sub>B</sub> <math>f_{CTQIN} = f_{PDIV}</math></p> <p>01<sub>B</sub> <math>f_{CTQIN} = f_{PPP}</math></p> <p>10<sub>B</sub> <math>f_{CTQIN} = f_{SCLK}</math></p> <p>11<sub>B</sub> <math>f_{CTQIN} = f_{MCLK}</math></p>



**Universal Serial Interface Channel (USIC)**

Field	Bits	Type	Description
<b>PCTQ</b>	[9:8]	rw	<b>Pre-Divider for Time Quanta Counter</b> This bit field defines length of a time quantum $t_q$ for the time quanta counter in the protocol pre-processor. $t_Q = (PCTQ + 1) / f_{CTQIN}$
<b>DCTQ</b>	[14:10]	rw	<b>Denominator for Time Quanta Counter</b> This bit field defines the number of time quanta $t_q$ taken into account by the time quanta counter in the protocol pre-processor.
<b>PDIV</b>	[25:16]	rw	<b>Divider Mode: Divider Factor to Generate <math>f_{PDIV}</math></b> This bit field defines the ratio between the input frequency $f_{PPP}$ and the divider frequency $f_{PDIV}$ .
<b>SCLKOSEL</b>	28	rw	<b>Shift Clock Output Select</b> This bit field selects the input source for the SCLKOUT signal. $0_B$ SCLK from the baud rate generator is selected as the SCLKOUT input source. $1_B$ The transmit shift clock from DX1 input stage is selected as the SCLKOUT input source.  <i>Note: The setting SCLKOSEL = 1 is used only when complete closed loop delay compensation is required for a slave SSC/IIS. The default setting of SCLKOSEL = 0 should be always used for all other cases.</i>
<b>MCLKCFG</b>	29	rw	<b>Master Clock Configuration</b> This bit field defines the level of the passive phase of the MCLKOUT signal. $0_B$ The passive level is 0. $1_B$ The passive level is 1.
<b>SCLKCFG</b>	[31:30]	rw	<b>Shift Clock Output Configuration</b> This bit field defines the level of the passive phase of the SCLKOUT signal and enables/disables a delay of half of a SCLK period. $00_B$ The passive level is 0 and the delay is disabled. $01_B$ The passive level is 1 and the delay is disabled. $10_B$ The passive level is 0 and the delay is enabled. $11_B$ The passive level is 1 and the delay is enabled.
<b>0</b>	2, 5, 15, [27:26]	r	<b>Reserved</b> Read as 0; should be written with 0.

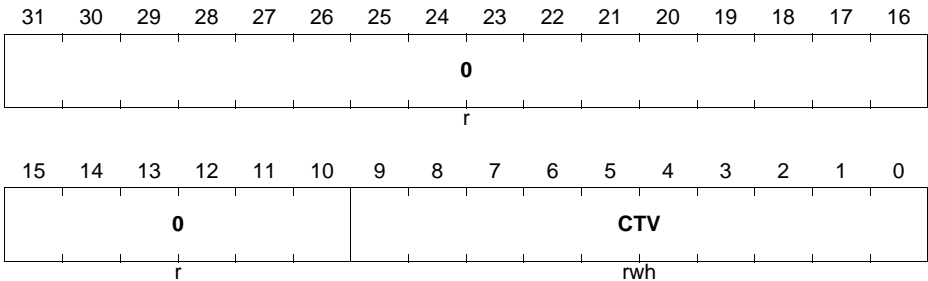
**Universal Serial Interface Channel (USIC)**

**15.11.6.3 Capture Mode Timer Register**

The captured timer value is provided by the register CMTR.

**CMTR**

**Capture Mode Timer Register (44<sub>H</sub>) Reset Value: 0000 0000<sub>H</sub>**



Field	Bits	Type	Description
CTV	[9:0]	rwh	<b>Captured Timer Value</b> The value of the counter is captured into this bit field if one of the trigger signals DX0T or DX1T are activated by the corresponding input stage.
0	[31:10]	r	<b>Reserved</b> Read as 0; should be written with 0.

**15.11.7 Transfer Control and Status Registers**

**15.11.7.1 Shift Control Register**

The data shift unit is controlled by the register SCTR. The values in this register are applied for data transmission and reception.

Please note that the shift control settings SDIR, WLE, FLE, DSM and HPCDIR are shared between transmitter and receiver. They are internally “frozen” for a each data word transfer in the transmitter with the first transmit shift clock edge and with the first receive shift clock edge in the receiver. The software has to take care that updates of these bit fields by software are done coherently (e.g. refer to the receiver start event indication PSR.RSIF).

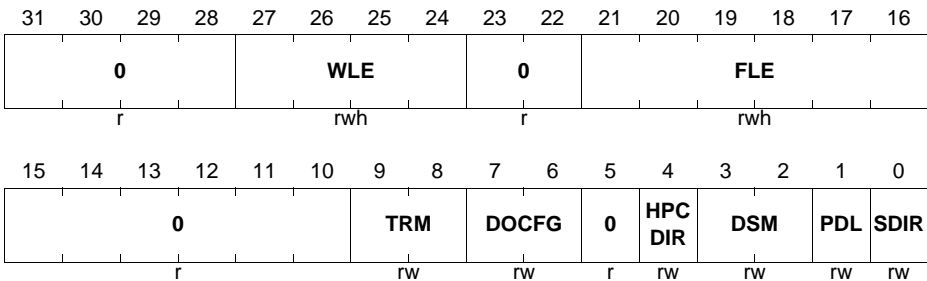
**Universal Serial Interface Channel (USIC)**

**SCTR**

**Shift Control Register**

**(34<sub>H</sub>)**

**Reset Value: 0000 0000<sub>H</sub>**



Field	Bits	Type	Description
<b>SDIR</b>	0	rw	<p><b>Shift Direction</b></p> <p>This bit defines the shift direction of the data words for transmission and reception.</p> <p>0<sub>B</sub> Shift LSB first. The first data bit of a data word is located at bit position 0.</p> <p>1<sub>B</sub> Shift MSB first. The first data bit of a data word is located at the bit position given by bit field SCTR.WLE.</p>
<b>PDL</b>	1	rw	<p><b>Passive Data Level</b></p> <p>This bit defines the output level at the shift data output signal when no data is available for transmission. The PDL level is output with the first relevant transmit shift clock edge of a data word.</p> <p>0<sub>B</sub> The passive data level is 0.</p> <p>1<sub>B</sub> The passive data level is 1.</p>

**Universal Serial Interface Channel (USIC)**

Field	Bits	Type	Description
<b>DSM</b>	[3:2]	rw	<p><b>Data Shift Mode</b></p> <p>This bit field describes how the receive and transmit data is shifted in and out.</p> <p>00<sub>B</sub> Receive and transmit data is shifted in and out one bit at a time through DX0 and DOUT0.</p> <p>01<sub>B</sub> Reserved.</p> <p>10<sub>B</sub> Receive and transmit data is shifted in and out two bits at a time through two input stages (DX0 and DX3) and DOUT[1:0] respectively.</p> <p>11<sub>B</sub> Receive and transmit data is shifted in and out four bits at a time through four input stages (DX0, DX[5:3]) and DOUT[3:0] respectively.</p> <p><i>Note: Dual- and Quad-output modes are used only by the SSC protocol. For all other protocols DSM must always be written with 00<sub>B</sub>.</i></p>
<b>HPCDIR</b>	4	rw	<p><b>Port Control Direction</b></p> <p>This bit defines the direction of the port pin(s) which allows hardware pin control (CCR.PCEN = 1).</p> <p>0<sub>B</sub> The pin(s) with hardware pin control enabled are selected to be in input mode.</p> <p>1<sub>B</sub> The pin(s) with hardware pin control enabled are selected to be in output mode.</p>
<b>DOCFG</b>	[7:6]	rw	<p><b>Data Output Configuration</b></p> <p>This bit defines the relation between the internal shift data value and the data output signal DOUTx.</p> <p>X0<sub>B</sub> DOUTx = shift data value</p> <p>X1<sub>B</sub> DOUTx = inverted shift data value</p>

**Universal Serial Interface Channel (USIC)**

<b>Field</b>	<b>Bits</b>	<b>Type</b>	<b>Description</b>
<b>TRM</b>	[9:8]	rw	<p><b>Transmission Mode</b></p> <p>This bit field describes how the shift control signal is interpreted by the DSU. Data transfers are only possible while the shift control signal is active.</p> <p>00<sub>B</sub> The shift control signal is considered as inactive and data frame transfers are not possible.</p> <p>01<sub>B</sub> The shift control signal is considered active if it is at 1-level. This is the setting to be programmed to allow data transfers.</p> <p>10<sub>B</sub> The shift control signal is considered active if it is at 0-level. It is recommended to avoid this setting and to use the inversion in the DX2 stage in case of a low-active signal.</p> <p>11<sub>B</sub> The shift control signal is considered active without referring to the actual signal level. Data frame transfer is possible after each edge of the signal.</p>
<b>FLE</b>	[21:16]	rwh	<p><b>Frame Length</b></p> <p>This bit field defines how many bits are transferred within a data frame. A data frame can consist of several concatenated data words.</p> <p>If TCSR.FLEMD = 1, the value can be updated automatically by the data handler.</p>
<b>WLE</b>	[27:24]	rwh	<p><b>Word Length</b></p> <p>This bit field defines the data word length (amount of bits that are transferred in each data word) for reception and transmission. The data word is always right-aligned in the data buffer at the bit positions [WLE down to 0].</p> <p>If TCSR.WLEMD = 1, the value can be updated automatically by the data handler.</p> <p>0<sub>H</sub> The data word contains 1 data bit located at bit position 0.</p> <p>1<sub>H</sub> The data word contains 2 data bits located at bit positions [1:0].</p> <p>...</p> <p>E<sub>H</sub> The data word contains 15 data bits located at bit positions [14:0].</p> <p>F<sub>H</sub> The data word contains 16 data bits located at bit positions [15:0].</p>

**Universal Serial Interface Channel (USIC)**

Field	Bits	Type	Description
<b>0</b>	5, [15:10], [23:22], [31:28]	r	<b>Reserved</b> Read as 0; should be written with 0.

### 15.11.7.2 Transmission Control and Status Register

The data transmission is controlled and monitored by register TCSR.

#### TCSR

**Transmit Control/Status Register (38<sub>H</sub>)**      **Reset Value: 0000 0000<sub>H</sub>**

31	30	29	28	27	26	25	24	23	22	21	20	19	18	17	16
<b>0</b>			<b>TE</b>	<b>TVC</b>	<b>TV</b>	<b>0</b>	<b>TSO F</b>				<b>0</b>				
r			rh	rh	rh	r	rh				r				
15	14	13	12	11	10	9	8	7	6	5	4	3	2	1	0
<b>0</b>	<b>WA</b>	<b>TDV TR</b>	<b>TDEN</b>		<b>0</b>	<b>TDS SM</b>	<b>TDV</b>	<b>EOF</b>	<b>SOF</b>	<b>HPC MD</b>	<b>WA MD</b>	<b>FLE MD</b>	<b>SEL MD</b>	<b>WLE MD</b>	
r	rwh	rw	rw		r	rw	rh	rwh	rw	rw	rw	rw	rw	rw	rw

Field	Bits	Type	Description
<b>WLEMD</b>	0	rw	<b>WLE Mode</b> This bit enables the data handler to automatically update the bit field SCTR.WLE by the transmit control information TCI[3:0] and bit TCSR.EOF by TCI[4] (see <a href="#">Page 15-32</a> ). If enabled, an automatic update takes place when new data is loaded to register TBUF, either by writing to one of the transmit buffer input locations TBUF <sub>x</sub> or by an optional data buffer. 0 <sub>B</sub> The automatic update of SCTR.WLE and TCSR.EOF is disabled. 1 <sub>B</sub> The automatic update of SCTR.WLE and TCSR.EOF is enabled.

**Universal Serial Interface Channel (USIC)**

<b>Field</b>	<b>Bits</b>	<b>Type</b>	<b>Description</b>
<b>SELMD</b>	1	rw	<p><b>Select Mode</b></p> <p>This bit can be used mainly for the SSC protocol. It enables the data handler to automatically update bit field PCR.CTR[20:16] by the transmit control information TCI[4:0] and clear bit field PCR.CTR[23:21] (see <a href="#">Page 15-32</a>). If enabled, an automatic update takes place when new data is loaded to register TBUF, either by writing to one of the transmit buffer input locations TBUFx or by an optional data buffer.</p> <p>0<sub>B</sub> The automatic update of PCR.CTR[23:16] is disabled.</p> <p>1<sub>B</sub> The automatic update of PCR.CTR[23:16] is disabled.</p>
<b>FLEMD</b>	2	rw	<p><b>FLE Mode</b></p> <p>This bit enables the data handler to automatically update bits SCTR.FLE[4:0] by the transmit control information TCI[4:0] and to clear bit SCTR.FLE[5] (see <a href="#">Page 15-32</a>). If enabled, an automatic update takes place when new data is loaded to register TBUF, either by writing to one of the transmit buffer input locations TBUFx or by an optional data buffer.</p> <p>0<sub>B</sub> The automatic update of FLE is disabled.</p> <p>1<sub>B</sub> The automatic update of FLE is enabled.</p>
<b>WAMD</b>	3	rw	<p><b>WA Mode</b></p> <p>This bit can be used mainly for the IIS protocol. It enables the data handler to automatically update bit TCSR.WA by the transmit control information TCI[4] (see <a href="#">Page 15-32</a>). If enabled, an automatic update takes place when new data is loaded to register TBUF, either by writing to one of the transmit buffer input locations TBUFx or by an optional data buffer.</p> <p>0<sub>B</sub> The automatic update of bit WA is disabled.</p> <p>1<sub>B</sub> The automatic update of bit WA is enabled.</p>

**Universal Serial Interface Channel (USIC)**

<b>Field</b>	<b>Bits</b>	<b>Type</b>	<b>Description</b>
<b>HPCMD</b>	4	rw	<p><b>Hardware Port Control Mode</b></p> <p>This bit can be used mainly for the dual and quad SSC protocol. It enables the data handler to automatically update bit SCTR.DSM by the transmit control information TCI[1:0] and bit SCTR.HPCDIR by TCI[2] (see <a href="#">Page 15-32</a>). If enabled, an automatic update takes place when new data is loaded to register TBUF, either by writing to one of the transmit buffer input locations TBUFx or by an optional data buffer.</p> <p>0<sub>B</sub> The automatic update of bits SCTR.DSM and SCTR.HPCDIR is disabled.</p> <p>1<sub>B</sub> The automatic update of bits SCTR.DSM and SCTR.HPCDIR is enabled.</p>
<b>SOF</b>	5	rw	<p><b>Start Of Frame</b></p> <p>This bit is only taken into account for the SSC protocol, otherwise it is ignored.</p> <p>It indicates that the data word in TBUF is considered as the first word of a new SSC frame if it is valid for transmission (TCSR.TDV = 1). This bit becomes cleared when the TBUF data word is transferred to the transmit shift register.</p> <p>0<sub>B</sub> The data word in TBUF is not considered as first word of a frame.</p> <p>1<sub>B</sub> The data word in TBUF is considered as first word of a frame. A currently running frame is finished and MSLs becomes deactivated (respecting the programmed delays).</p>



**Universal Serial Interface Channel (USIC)**

<b>Field</b>	<b>Bits</b>	<b>Type</b>	<b>Description</b>
<b>EOF</b>	6	rwh	<p><b>End Of Frame</b></p> <p>This bit is only taken into account for the SSC protocol, otherwise it is ignored. It can be modified automatically by the data handler if bit WLEMD = 1. It indicates that the data word in TBUF is considered as the last word of an SSC frame. If it is the last word, the MSLS signal becomes inactive after the transfer, respecting the programmed delays. This bit becomes cleared when the TBUF data word is transferred to the transmit shift register.</p> <p>0<sub>B</sub> The data word in TBUF is not considered as last word of an SSC frame.</p> <p>1<sub>B</sub> The data word in TBUF is considered as last word of an SSC frame.</p>
<b>TDV</b>	7	rh	<p><b>Transmit Data Valid</b></p> <p>This bit indicates that the data word in the transmit buffer TBUF can be considered as valid for transmission. The TBUF data word can only be sent out if TDV = 1. It is automatically set when data is moved to TBUF (by writing to one of the transmit buffer input locations TBUFx, or optionally, by the bypass or FIFO mechanism).</p> <p>0<sub>B</sub> The data word in TBUF is not valid for transmission.</p> <p>1<sub>B</sub> The data word in TBUF is valid for transmission and a transmission start is possible. New data should not be written to a TBUFx input location while TDV = 1.</p>

**Universal Serial Interface Channel (USIC)**

Field	Bits	Type	Description
<b>TDSSM</b>	8	rw	<p><b>TBUF Data Single Shot Mode</b></p> <p>This bit defines if the data word TBUF data is considered as permanently valid or if the data should only be transferred once.</p> <p>0<sub>B</sub> The data word in TBUF is not considered as invalid after it has been loaded into the transmit shift register. The loading of the TBUF data into the shift register does not clear TDV.</p> <p>1<sub>B</sub> The data word in TBUF is considered as invalid after it has been loaded into the shift register. In ASC and IIC mode, TDV is cleared with the TBI event, whereas in SSC and IIS mode, it is cleared with the RSI event.</p> <p>TDSSM = 1 has to be programmed if an optional data buffer is used.</p>
<b>TDEN</b>	[11:10]	rw	<p><b>TBUF Data Enable</b></p> <p>This bit field controls the gating of the transmission start of the data word in the transmit buffer TBUF.</p> <p>00<sub>B</sub> A transmission start of the data word in TBUF is disabled. If a transmission is started, the passive data level is sent out.</p> <p>01<sub>B</sub> A transmission of the data word in TBUF can be started if TDV = 1.</p> <p>10<sub>B</sub> A transmission of the data word in TBUF can be started if TDV = 1 while DX2S = 0.</p> <p>11<sub>B</sub> A transmission of the data word in TBUF can be started if TDV = 1 while DX2S = 1.</p>
<b>TDVTR</b>	12	rw	<p><b>TBUF Data Valid Trigger</b></p> <p>This bit enables the transfer trigger unit to set bit TCSR.TE if the trigger signal DX2T becomes active for event driven transfer starts, e.g. timer-based or depending on an event at an input pin. Bit TDVTR has to be 0 for protocols where the input stage DX2 is used for data shifting.</p> <p>0<sub>B</sub> Bit TCSR.TE is permanently set.</p> <p>1<sub>B</sub> Bit TCSR.TE is set if DX2T becomes active while TDV = 1.</p>

**Universal Serial Interface Channel (USIC)**

<b>Field</b>	<b>Bits</b>	<b>Type</b>	<b>Description</b>
<b>WA</b>	13	rwh	<p><b>Word Address</b></p> <p>This bit is only taken into account for the IIS protocol, otherwise it is ignored. It can be modified automatically by the data handler if bit WAMD = 1. Bit WA defines for which channel the data stored in TBUF will be transmitted.</p> <p>0<sub>B</sub> The data word in TBUF will be transmitted after a falling edge of WA has been detected (referring to PSR.WA).</p> <p>1<sub>B</sub> The data word in TBUF will be transmitted after a rising edge of WA has been detected (referring to PSR.WA).</p>
<b>TSOF</b>	24	rh	<p><b>Transmitted Start Of Frame</b></p> <p>This bit indicates if the latest start of a data word transmission has taken place for the first data word of a new data frame. This bit is updated with the transmission start of each data word.</p> <p>0<sub>B</sub> The latest data word transmission has not been started for the first word of a data frame.</p> <p>1<sub>B</sub> The latest data word transmission has been started for the first word of a data frame.</p>
<b>TV</b>	26	rh	<p><b>Transmission Valid</b></p> <p>This bit represents the transmit buffer underflow and indicates if the latest start of a data word transmission has taken place with a valid data word from the transmit buffer TBUF. This bit is updated with the transmission start of each data word.</p> <p>0<sub>B</sub> The latest start of a data word transmission has taken place while no valid data was available. As a result, the transmission of a data words with passive level (SCTR.PDL) has been started.</p> <p>1<sub>B</sub> The latest start of a data word transmission has taken place with valid data from TBUF.</p>

**Universal Serial Interface Channel (USIC)**

<b>Field</b>	<b>Bits</b>	<b>Type</b>	<b>Description</b>
<b>TVC</b>	27	rh	<p><b>Transmission Valid Cumulated</b></p> <p>This bit cumulates the transmit buffer underflow indication TV. It is cleared automatically together with bit TV and has to be set by writing FMR.ATVC = 1.</p> <p>0<sub>B</sub> Since TVC has been set, at least one data buffer underflow condition has occurred.</p> <p>1<sub>B</sub> Since TVC has been set, no data buffer underflow condition has occurred.</p>
<b>TE</b>	28	rh	<p><b>Trigger Event</b></p> <p>If the transfer trigger mechanism is enabled, this bit indicates that a trigger event has been detected (DX2T = 1) while TCSR.TDV = 1. If the event trigger mechanism is disabled, the bit TE is permanently set. It is cleared by writing FMR.MTDV = 10<sub>B</sub> or when the data word located in TBUF is loaded into the shift register.</p> <p>0<sub>B</sub> The trigger event has not yet been detected. A transmission of the data word in TBUF can not be started.</p> <p>1<sub>B</sub> The trigger event has been detected (or the trigger mechanism is switched off) and a transmission of the data word in TBUF can be started.</p>
<b>0</b>	9, [23:14], 25, [31:29]	r	<p><b>Reserved</b></p> <p>Read as 0; should be written with 0.</p>

### 15.11.7.3 Flag Modification Registers

The flag modification register FMR allows the modification of control and status flags related to data handling by using only write accesses. Read accesses to FMR always deliver 0 at all bit positions.

Additionally, the service request outputs of this USIC channel can be activated by software (the activation is triggered by the write access and is deactivated automatically).

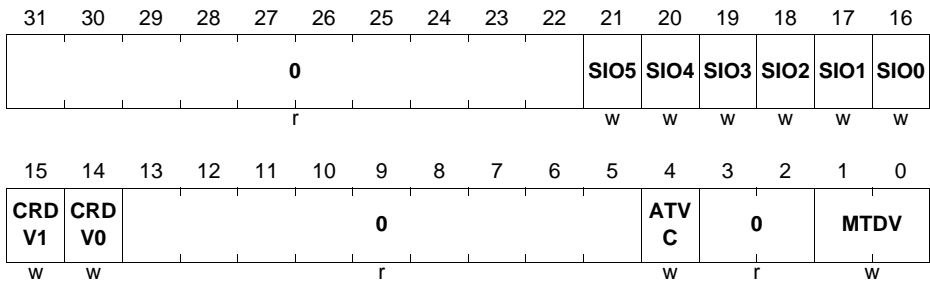
**Universal Serial Interface Channel (USIC)**

**FMR**

**Flag Modification Register**

**(68<sub>H</sub>)**

**Reset Value: 0000 0000<sub>H</sub>**



Field	Bits	Type	Description
<b>MTDV</b>	[1:0]	w	<p><b>Modify Transmit Data Valid</b></p> <p>Writing to this bit field can modify bits TCSR.TDV and TCSR.TE to control the start of a data word transmission by software.</p> <p>00<sub>B</sub> No action.</p> <p>01<sub>B</sub> Bit TDV is set, TE is unchanged.</p> <p>10<sub>B</sub> Bits TDV and TE are cleared.</p> <p>11<sub>B</sub> Reserved</p>
<b>ATVC</b>	4	w	<p><b>Activate Bit TVC</b></p> <p>Writing to this bit can set bit TCSR.TVC to start a new cumulation of the transmit buffer underflow condition.</p> <p>0<sub>B</sub> No action.</p> <p>1<sub>B</sub> Bit TCSR.TVC is set.</p>
<b>CRDV0</b>	14	w	<p><b>Clear Bits RDV for RBUF0</b></p> <p>Writing 1 to this bit clears bits RBUF01SR.RDV00 and RBUF01SR.RDV10 to declare the received data in RBUF0 as no longer valid (to emulate a read action).</p> <p>0<sub>B</sub> No action.</p> <p>1<sub>B</sub> Bits RBUF01SR.RDV00 and RBUF01SR.RDV10 are cleared.</p>

**Universal Serial Interface Channel (USIC)**

Field	Bits	Type	Description
<b>CRDV1</b>	15	w	<p><b>Clear Bit RDV for RBUF1</b></p> <p>Writing 1 to this bit clears bits RBUF01SR.RDV01 and RBUF01SR.RDV11 to declare the received data in RBUF1 as no longer valid (to emulate a read action).</p> <p>0<sub>B</sub> No action. 1<sub>B</sub> Bits RBUF01SR.RDV01 and RBUF01SR.RDV11 are cleared.</p>
<b>SIO0, SIO1, SIO2, SIO3, SIO4, SIO5</b>	16, 17, 18, 19, 20, 21	w	<p><b>Set Interrupt Output SRx</b></p> <p>Writing a 1 to this bit field activates the service request output SRx of this USIC channel. It has no impact on service request outputs of other USIC channels.</p> <p>0<sub>B</sub> No action. 1<sub>B</sub> The service request output SRx is activated.</p>
<b>0</b>	[3:2], [13:5], [31:22]	r	<p><b>Reserved</b></p> <p>Read as 0; should be written with 0.</p>

## 15.11.8 Data Buffer Registers

### 15.11.8.1 Transmit Buffer Locations

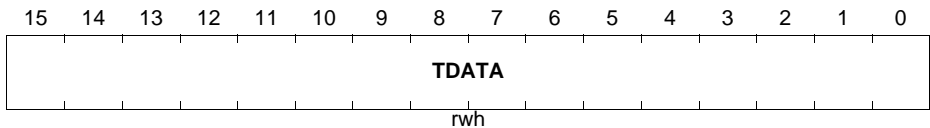
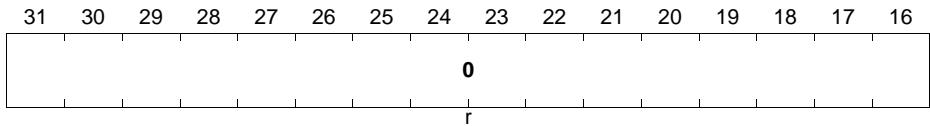
The 32 independent data input locations TBUF00 to TBUF31 are address locations that can be used as data entry locations for the transmit buffer. Data written to one of these locations will appear in a common register TBUF. Additionally, the 5 bit coding of the number [31:0] of the addressed data input location represents the transmit control information TCI (please refer to the protocol sections for more details).

The internal transmit buffer register TBUF contains the data that will be loaded to the transmit shift register for the next transmission of a data word. It can be read out at all TBUF00 to TBUF31 addresses.

**Universal Serial Interface Channel (USIC)**

**TBUF<sub>x</sub> (x = 00-31)**

**Transmit Buffer Input Location x (80<sub>H</sub> + x\*4)                      Reset Value: 0000 0000<sub>H</sub>**



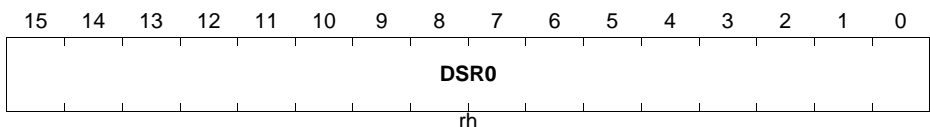
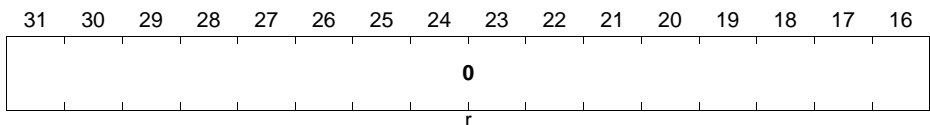
Field	Bits	Type	Description
TDATA	[15:0]	rwh	<b>Transmit Data</b> This bit field contains the data to be transmitted (read view). A data write action to at least the low byte of TDATA sets TCSR.TDV.
0	[31:16]	r	<b>Reserved</b> Read as 0; should be written with 0.

**15.11.8.2 Receive Buffer Registers RBUF0, RBUF1**

The receive buffer register RBUF0 contains the data received from RSR0[3:0]. A read action does not change the status of the receive data from “not yet read = valid” to “already read = not valid”.

**RBUF0**

**Receiver Buffer Register 0    (5C<sub>H</sub>)                      Reset Value: 0000 0000<sub>H</sub>**



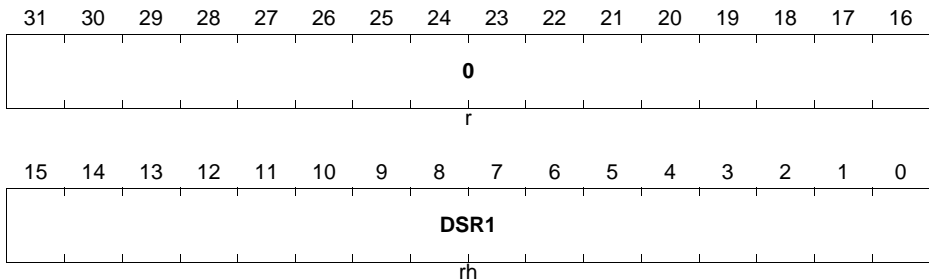
**Universal Serial Interface Channel (USIC)**

Field	Bits	Type	Description
<b>DSR0</b>	[15:0]	rh	<b>Data of Shift Registers 0[3:0]</b>
<b>0</b>	[31:16]	r	<b>Reserved</b> Read as 0; should be written with 0.

The receive buffer register RBUF1 contains the data received from RSR1[3:0]. A read action does not change the status of the receive data from “not yet read = valid” to “already read = not valid”.

**RBUF1**

**Receiver Buffer Register 1** (60<sub>H</sub>) **Reset Value: 0000 0000<sub>H</sub>**



Field	Bits	Type	Description
<b>DSR1</b>	[15:0]	rh	<b>Data of Shift Registers 1[3:0]</b>
<b>0</b>	[31:16]	r	<b>Reserved</b> Read as 0; should be written with 0.

The receive buffer status register RBUF01SR provides the status of the data in receive buffers RBUF0 and RBUF1.



**Universal Serial Interface Channel (USIC)**

**RBUF01SR**

**Receiver Buffer 01 Status Register (64<sub>H</sub>)**

**Reset Value: 0000 0000<sub>H</sub>**

31	30	29	28	27	26	25	24	23	22	21	20	19	18	17	16
<b>DS1</b>	<b>RDV 11</b>	<b>RDV 10</b>	<b>0</b>			<b>PER R1</b>	<b>PAR 1</b>	<b>0</b>	<b>SOF 1</b>	<b>0</b>	<b>WLEN1</b>				
rh	rh	rh	r			rh	rh	r	rh	r	rh				
15	14	13	12	11	10	9	8	7	6	5	4	3	2	1	0
<b>DS0</b>	<b>RDV 01</b>	<b>RDV 00</b>	<b>0</b>			<b>PER R0</b>	<b>PAR 0</b>	<b>0</b>	<b>SOF 0</b>	<b>0</b>	<b>WLEN0</b>				
rh	rh	rh	r			rh	rh	r	rh	r	rh				

Field	Bits	Type	Description
<b>WLEN0</b>	[3:0]	rh	<p><b>Received Data Word Length in RBUF0</b></p> <p>This bit field indicates how many bits have been received within the last data word stored in RBUF0. This number indicates how many data bits have to be considered as receive data, whereas the other bits in RBUF0 have been cleared automatically. The received bits are always right-aligned.</p> <p>For all protocol modes besides dual and quad SSC, Received data word length = WLEN0 + 1</p> <p>For dual SSC mode, Received data word length = WLEN0 + 2</p> <p>For quad SSC mode, Received data word length = WLEN0 + 4</p>
<b>SOF0</b>	6	rh	<p><b>Start of Frame in RBUF0</b></p> <p>This bit indicates whether the data word in RBUF0 has been the first data word of a data frame.</p> <p>0<sub>B</sub> The data in RBUF0 has not been the first data word of a data frame.</p> <p>1<sub>B</sub> The data in RBUF0 has been the first data word of a data frame.</p>

**Universal Serial Interface Channel (USIC)**

<b>Field</b>	<b>Bits</b>	<b>Type</b>	<b>Description</b>
<b>PAR0</b>	8	rh	<p><b>Protocol-Related Argument in RBUF0</b></p> <p>This bit indicates the value of the protocol-related argument. This value is elaborated depending on the selected protocol and adds additional information to the data word in RBUF0.</p> <p>The meaning of this bit is described in the corresponding protocol chapter.</p>
<b>PERR0</b>	9	rh	<p><b>Protocol-related Error in RBUF0</b></p> <p>This bit indicates if the value of the protocol-related argument meets an expected value. This value is elaborated depending on the selected protocol and adds additional information to the data word in RBUF0.</p> <p>The meaning of this bit is described in the corresponding protocol chapter.</p> <p>0<sub>B</sub> The received protocol-related argument PAR matches the expected value. The reception of the data word sets bit PSR.RIF and can generate a receive interrupt.</p> <p>1<sub>B</sub> The received protocol-related argument PAR does not match the expected value. The reception of the data word sets bit PSR.AIF and can generate an alternative receive interrupt.</p>
<b>RDV00</b>	13	rh	<p><b>Receive Data Valid in RBUF0</b></p> <p>This bit indicates the status of the data content of register RBUF0. This bit is identical to bit RBUF01SR.RDV10 and allows consisting reading of information for the receive buffer registers. It is set when a new data word is stored in RBUF0 and automatically cleared if it is read out via RBUF.</p> <p>0<sub>B</sub> Register RBUF0 does not contain data that has not yet been read out.</p> <p>1<sub>B</sub> Register RBUF0 contains data that has not yet been read out.</p>

**Universal Serial Interface Channel (USIC)**

<b>Field</b>	<b>Bits</b>	<b>Type</b>	<b>Description</b>
<b>RDV01</b>	14	rh	<p><b>Receive Data Valid in RBUF1</b></p> <p>This bit indicates the status of the data content of register RBUF1. This bit is identical to bit RBUF01SR.RDV11 and allows consisting reading of information for the receive buffer registers. It is set when a new data word is stored in RBUF1 and automatically cleared if it is read out via RBUF.</p> <p>0<sub>B</sub> Register RBUF1 does not contain data that has not yet been read out.</p> <p>1<sub>B</sub> Register RBUF1 contains data that has not yet been read out.</p>
<b>DS0</b>	15	rh	<p><b>Data Source</b></p> <p>This bit indicates which receive buffer register (RBUF0 or RBUF1) is currently visible in registers RBUF(D) and in RBUF0SR for the associated status information. It indicates which buffer contains the oldest data (the data that has been received first). This bit is identical to bit RBUF01SR.DS1 and allows consisting reading of information for the receive buffer registers.</p> <p>0<sub>B</sub> The register RBUF contains the data of RBUF0 (same for associated status information).</p> <p>1<sub>B</sub> The register RBUF contains the data of RBUF1 (same for associated status information).</p>
<b>WLEN1</b>	[19:16]	rh	<p><b>Received Data Word Length in RBUF1</b></p> <p>This bit field indicates how many bits have been received within the last data word stored in RBUF1. This number indicates how many data bits have to be considered as receive data, whereas the other bits in RBUF1 have been cleared automatically. The received bits are always right-aligned.</p> <p>For all protocol modes besides dual and quad SSC, Received data word length = WLEN1 + 1</p> <p>For dual SSC mode, Received data word length = WLEN1 + 2</p> <p>For quad SSC mode, Received data word length = WLEN1 + 4</p>

**Universal Serial Interface Channel (USIC)**

<b>Field</b>	<b>Bits</b>	<b>Type</b>	<b>Description</b>
<b>SOF1</b>	22	rh	<p><b>Start of Frame in RBUF1</b></p> <p>This bit indicates whether the data word in RBUF1 has been the first data word of a data frame.</p> <p>0<sub>B</sub> The data in RBUF1 has not been the first data word of a data frame.</p> <p>1<sub>B</sub> The data in RBUF1 has been the first data word of a data frame.</p>
<b>PAR1</b>	24	rh	<p><b>Protocol-Related Argument in RBUF1</b></p> <p>This bit indicates the value of the protocol-related argument. This value is elaborated depending on the selected protocol and adds additional information to the data word in RBUF1.</p> <p>The meaning of this bit is described in the corresponding protocol chapter.</p>
<b>PERR1</b>	25	rh	<p><b>Protocol-related Error in RBUF1</b></p> <p>This bit indicates if the value of the protocol-related argument meets an expected value. This value is elaborated depending on the selected protocol and adds additional information to the data word in RBUF1.</p> <p>The meaning of this bit is described in the corresponding protocol chapter.</p> <p>0<sub>B</sub> The received protocol-related argument PAR matches the expected value. The reception of the data word sets bit PSR.RIF and can generate a receive interrupt.</p> <p>1<sub>B</sub> The received protocol-related argument PAR does not match the expected value. The reception of the data word sets bit PSR.AIF and can generate an alternative receive interrupt.</p>
<b>RDV10</b>	29	rh	<p><b>Receive Data Valid in RBUF0</b></p> <p>This bit indicates the status of the data content of register RBUF0. This bit is identical to bit RBUF01SR.RDV00 and allows consistent reading of information for the receive buffer registers.</p> <p>0<sub>B</sub> Register RBUF0 does not contain data that has not yet been read out.</p> <p>1<sub>B</sub> Register RBUF0 contains data that has not yet been read out.</p>

**Universal Serial Interface Channel (USIC)**

Field	Bits	Type	Description
<b>RDV11</b>	30	rh	<p><b>Receive Data Valid in RBUF1</b></p> <p>This bit indicates the status of the data content of register RBUF1. This bit is identical to bit RBUF01SR.RDV01 and allows consisting reading of information for the receive buffer registers.</p> <p>0<sub>B</sub> Register RBUF1 does not contain data that has not yet been read out.</p> <p>1<sub>B</sub> Register RBUF1 contains data that has not yet been read out.</p>
<b>DS1</b>	31	rh	<p><b>Data Source</b></p> <p>This bit indicates which receive buffer register (RBUF0 or RBUF1) is currently visible in registers RBUF(D) and in RBUF0SR for the associated status information. It indicates which buffer contains the oldest data (the data that has been received first). This bit is identical to bit RBUF01SR.DS0 and allows consisting reading of information for the receive buffer registers.</p> <p>0<sub>B</sub> The register RBUF contains the data of RBUF0 (same for associated status information).</p> <p>1<sub>B</sub> The register RBUF contains the data of RBUF1 (same for associated status information).</p>
<b>0</b>	[5:4], 7, [12:10], [21:20], 23, [28:26]	r	<p><b>Reserved</b></p> <p>Read as 0; should be written with 0.</p>

### 15.11.8.3 Receive Buffer Registers RBUF, RBUFD, RBUF0SR

The receiver buffer register RBUF shows the content of the either RBUF0 or RBUF1, depending on the order of reception. Always the oldest data (the data word that has been received first) from both receive buffers can be read from RBUF. It is recommended to read out the received data from RBUF instead of RBUF0/1. With a read access of at least the low byte of RBUF, the status of the receive data is automatically changed from “not yet read = valid” to “already read = not valid”, the content of RBUF becomes updated, and the next received data word becomes visible in RBUF.

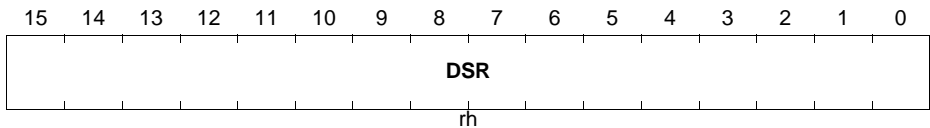
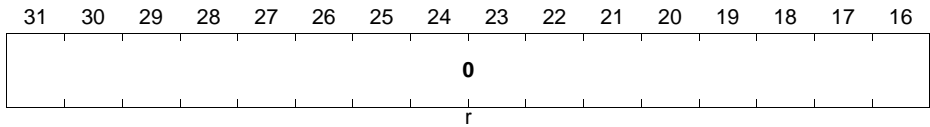
**Universal Serial Interface Channel (USIC)**

**RBUF**

**Receiver Buffer Register**

**(54<sub>H</sub>)**

**Reset Value: 0000 0000<sub>H</sub>**



Field	Bits	Type	Description
DSR	[15:0]	rh	<b>Received Data</b> This bit field monitors the content of either RBUF0 or RBUF1, depending on the reception sequence.
0	[31:16]	r	<b>Reserved</b> Read as 0; should be written with 0.

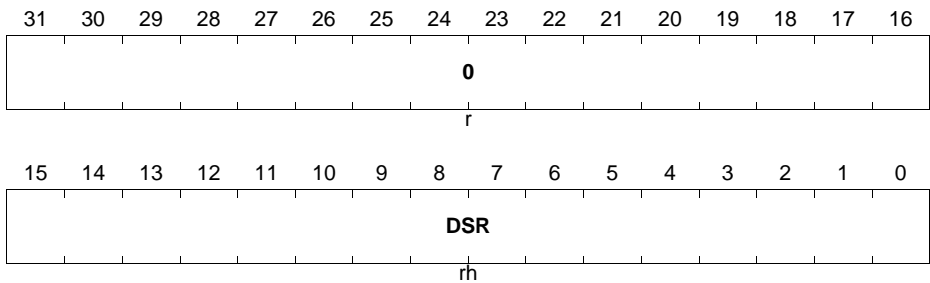
**Universal Serial Interface Channel (USIC)**

If a debugger should be used to monitor the received data, the automatic update mechanism has to be de-activated to guaranty data consistency. Therefore, the receiver buffer register for debugging RBUFD is available. It is similar to RBUF, but without the automatic update mechanism by a read action. So a debugger (or other monitoring function) can read RBUFD without disturbing the receive sequence.

**RBUFD**

**Receiver Buffer Register for Debugger(58<sub>H</sub>)**

**Reset Value: 0000 0000<sub>H</sub>**



Field	Bits	Type	Description
<b>DSR</b>	[15:0]	rh	<b>Data from Shift Register</b> Same as RBUF.DSR, but without releasing the buffer after a read action.
<b>0</b>	[31:16]	r	<b>Reserved</b> Read as 0; should be written with 0.

**Universal Serial Interface Channel (USIC)**

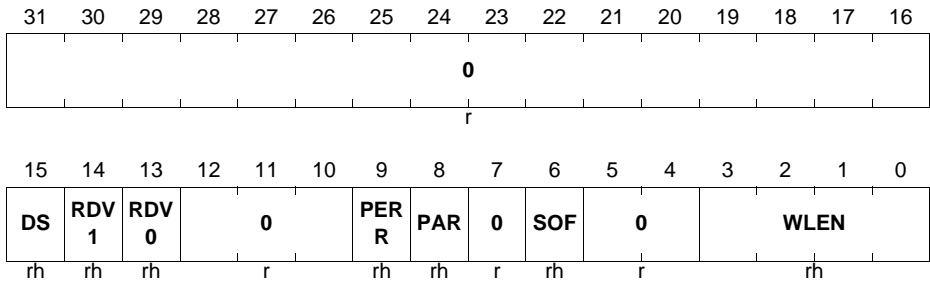
The receive buffer status register RBUF<sub>SR</sub> provides the status of the data in receive buffers RBUF and RBUFD. If bits RBUF<sub>01SR</sub>.DS<sub>0</sub> (or RBUF<sub>01SR</sub>.DS<sub>1</sub>) are 0, the lower 16-bit content of RBUF<sub>01SR</sub> is monitored in RBUF<sub>SR</sub>, otherwise the upper 16-bit content of RBUF<sub>01SR</sub> is shown.

**RBUF<sub>SR</sub>**

**Receiver Buffer Status Register**

**(50<sub>H</sub>)**

**Reset Value: 0000 0000<sub>H</sub>**



Field	Bits	Type	Description
<b>WLEN</b>	[3:0]	rh	<b>Received Data Word Length in RBUF or RBUFD</b> Description see RBUF <sub>01SR</sub> .WLEN <sub>0</sub> or RBUF <sub>01SR</sub> .WLEN <sub>1</sub> .
<b>SOF</b>	6	rh	<b>Start of Frame in RBUF or RBUFD</b> Description see RBUF <sub>01SR</sub> .SOF <sub>0</sub> or RBUF <sub>01SR</sub> .SOF <sub>1</sub> .
<b>PAR</b>	8	rh	<b>Protocol-Related Argument in RBUF or RBUFD</b> Description see RBUF <sub>01SR</sub> .PAR <sub>0</sub> or RBUF <sub>01SR</sub> .PAR <sub>1</sub> .
<b>PERR</b>	9	rh	<b>Protocol-related Error in RBUF or RBUFD</b> Description see RBUF <sub>01SR</sub> .PERR <sub>0</sub> or RBUF <sub>01SR</sub> .PERR <sub>1</sub> .
<b>RDV<sub>0</sub></b>	13	rh	<b>Receive Data Valid in RBUF or RBUFD</b> Description see RBUF <sub>01SR</sub> .RDV <sub>00</sub> or RBUF <sub>01SR</sub> .RDV <sub>10</sub> .
<b>RDV<sub>1</sub></b>	14	rh	<b>Receive Data Valid in RBUF or RBUFD</b> Description see RBUF <sub>01SR</sub> .RDV <sub>01</sub> or RBUF <sub>01SR</sub> .RDV <sub>11</sub> .



**Universal Serial Interface Channel (USIC)**

Field	Bits	Type	Description
<b>DS</b>	15	rh	<b>Data Source of RBUF or RBUFD</b> Description see RBUF01SR.DS0 or RBUF01SR.DS1.
<b>0</b>	[5:4], 7, [12:10], [31:16]	r	<b>Reserved</b> Read as 0; should be written with 0.

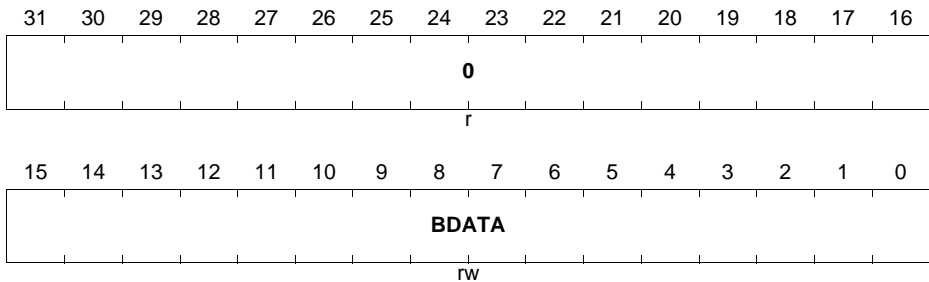
### 15.11.9 FIFO Buffer and Bypass Registers

#### 15.11.9.1 Bypass Registers

A write action to at least the low byte of the bypass data register sets BYPCR.BDV = 1 (bypass data tagged valid).

#### **BYP**

**Bypass Data Register (100<sub>H</sub>)**      **Reset Value: 0000 0000<sub>H</sub>**



Bit (Field)	Width	Type	Description
<b>BDATA</b>	[15:0]	rw	<b>Bypass Data</b> This bit field contains the bypass data.
<b>0</b>	[31:16]	r	<b>Reserved</b> Read as 0; should be written with 0.

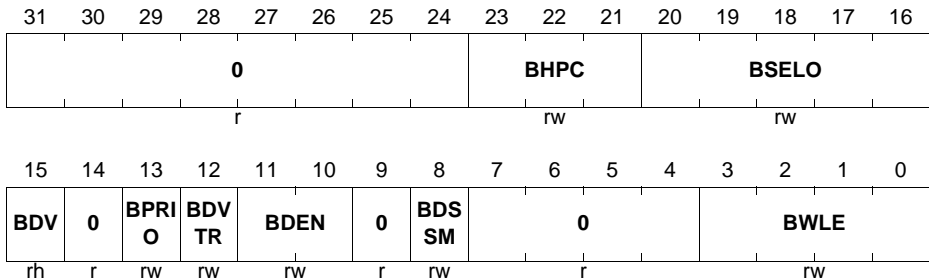
**Universal Serial Interface Channel (USIC)**

**BYPCCR**

**Bypass Control Register**

**(104<sub>H</sub>)**

**Reset Value: 0000 0000<sub>H</sub>**



Field	Bits	Type	Description
<b>BWLE</b>	[3:0]	rw	<p><b>Bypass Word Length</b></p> <p>This bit field defines the word length of the bypass data. The word length is given by BWLE + 1 with the data word being right-aligned in the data buffer at the bit positions [BWLE down to 0].</p> <p>The bypass data word is always considered as an own frame with the length of BWLE.</p> <p>Same coding as SCTR.WLE.</p>
<b>BDSSM</b>	8	rw	<p><b>Bypass Data Single Shot Mode</b></p> <p>This bit defines if the bypass data is considered as permanently valid or if the bypass data is only transferred once (single shot mode).</p> <p>0<sub>B</sub> The bypass data is still considered as valid after it has been loaded into TBUF. The loading of the data into TBUF does not clear BDV.</p> <p>1<sub>B</sub> The bypass data is considered as invalid after it has been loaded into TBUF. The loading of the data into TBUF clears BDV.</p>

**Universal Serial Interface Channel (USIC)**

<b>Field</b>	<b>Bits</b>	<b>Type</b>	<b>Description</b>
<b>BDEN</b>	[11:10]	rw	<p><b>Bypass Data Enable</b> This bit field defines if and how the transfer of bypass data to TBUF is enabled.</p> <p>00<sub>B</sub> The transfer of bypass data is disabled. 01<sub>B</sub> The transfer of bypass data to TBUF is possible. Bypass data will be transferred to TBUF according to its priority if BDV = 1. 10<sub>B</sub> Gated bypass data transfer is enabled. Bypass data will be transferred to TBUF according to its priority if BDV = 1 and while DX2S = 0. 11<sub>B</sub> Gated bypass data transfer is enabled. Bypass data will be transferred to TBUF according to its priority if BDV = 1 and while DX2S = 1.</p>
<b>BDVTR</b>	12	rw	<p><b>Bypass Data Valid Trigger</b> This bit enables the bypass data for being tagged valid when DX2T is active (for time framing or time-out purposes).</p> <p>0<sub>B</sub> Bit BDV is not influenced by DX2T. 1<sub>B</sub> Bit BDV is set if DX2T is active.</p>
<b>BPRIO</b>	13	rw	<p><b>Bypass Priority</b> This bit defines the priority between the bypass data and the transmit FIFO data.</p> <p>0<sub>B</sub> The transmit FIFO data has a higher priority than the bypass data. 1<sub>B</sub> The bypass data has a higher priority than the transmit FIFO data.</p>
<b>BDV</b>	15	rh	<p><b>Bypass Data Valid</b> This bit defines if the bypass data is valid for a transfer to TBUF. This bit is set automatically by a write access to at least the low-byte of register BYP. It can be cleared by software by writing TRBSCR.CBDV.</p> <p>0<sub>B</sub> The bypass data is not valid. 1<sub>B</sub> The bypass data is valid.</p>
<b>BSELO</b>	[20:16]	rw	<p><b>Bypass Select Outputs</b> This bit field contains the value that is written to PCR.CTR[20:16] if bypass data is transferred to TBUF while TCSR.SELMD = 1. In the SSC protocol, this bit field can be used to define which SELOx output line will be activated when bypass data is transmitted.</p>

**Universal Serial Interface Channel (USIC)**

Field	Bits	Type	Description
<b>BHPC</b>	[23:21]	rw	<p><b>Bypass Hardware Port Control</b></p> <p>This bit field contains the value that is written to SCTR[4:2] if bypass data is transferred to TBUF while TCSR.HPCMD = 1.</p> <p>In the SSC protocol, this bit field can be used to define the data shift mode and if hardware port control is enabled through CCR.HPCEN = 1, the pin direction when bypass data is transmitted.</p>
<b>0</b>	[7:4], 9, 14, [31:24]	r	<p><b>Reserved</b></p> <p>Read as 0; should be written with 0.</p>

### 15.11.9.2 General FIFO Buffer Control Registers

The transmit and receive FIFO status information of USICx\_CHy is given in registers USICx\_CHy.TRBSR.

The bits related to the transmitter buffer in this register can only be written if the transmit buffer functionality is enabled by CCFG.TB = 1, otherwise write accesses are ignored. A similar behavior applies for the bits related to the receive buffer referring to CCFG.RB = 1.

The interrupt flags (event flags) in the transmit and receive FIFO status register TRBSR can be cleared by writing a 1 to the corresponding bit position in register TRBSCR, whereas writing a 0 has no effect on these bits. Writing a 1 by software to SRBI, RBERI, ARBI, STBI, or TBERI sets the corresponding bit to simulate the detection of a transmit/receive buffer event, but without activating any service request output (therefore, see FMR.SIOx).

Bits TBUS and RBUS have been implemented for testing purposes. They can be ignored by data handling software. Please note that a read action can deliver either a 0 or a 1 for these bits. It is recommended to treat them as "don't care".

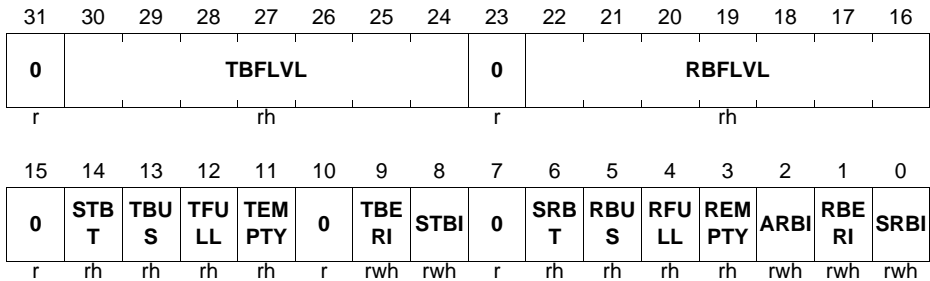
**Universal Serial Interface Channel (USIC)**

**TRBSR**

**Transmit/Receive Buffer Status Register**

(114<sub>H</sub>)

Reset Value: 0000 0808<sub>H</sub>



Field	Bits	Type	Description
<b>SRBI</b>	0	rwh	<p><b>Standard Receive Buffer Event</b></p> <p>This bit indicates that a standard receive buffer event has been detected. It is cleared by writing TRBSCR.CSRBI = 1.</p> <p>If enabled by RBCTR.SRBIEN, the service request output SRx selected by RBCTR.SRBINP becomes activated if a standard receive buffer event is detected.</p> <p>0<sub>B</sub> A standard receive buffer event has not been detected.</p> <p>1<sub>B</sub> A standard receive buffer event has been detected.</p>
<b>RBERI</b>	1	rwh	<p><b>Receive Buffer Error Event</b></p> <p>This bit indicates that a receive buffer error event has been detected. It is cleared by writing TRBSCR.CRBERI = 1.</p> <p>If enabled by RBCTR.RBERIEN, the service request output SRx selected by RBCTR.ARBINP becomes activated if a receive buffer error event is detected.</p> <p>0<sub>B</sub> A receive buffer error event has not been detected.</p> <p>1<sub>B</sub> A receive buffer error event has been detected.</p>

**Universal Serial Interface Channel (USIC)**

<b>Field</b>	<b>Bits</b>	<b>Type</b>	<b>Description</b>
<b>ARBI</b>	2	rwh	<p><b>Alternative Receive Buffer Event</b></p> <p>This bit indicates that an alternative receive buffer event has been detected. It is cleared by writing <code>TRBSCR.CARBI = 1</code>.</p> <p>If enabled by <code>RBCTR.ARBIEIN</code>, the service request output <code>SRx</code> selected by <code>RBCTR.ARBINP</code> becomes activated if an alternative receive buffer event is detected.</p> <p>0<sub>B</sub> An alternative receive buffer event has not been detected.</p> <p>1<sub>B</sub> An alternative receive buffer event has been detected.</p>
<b>REMPY</b>	3	rh	<p><b>Receive Buffer Empty</b></p> <p>This bit indicates whether the receive buffer is empty.</p> <p>0<sub>B</sub> The receive buffer is not empty.</p> <p>1<sub>B</sub> The receive buffer is empty.</p>
<b>RFULL</b>	4	rh	<p><b>Receive Buffer Full</b></p> <p>This bit indicates whether the receive buffer is full.</p> <p>0<sub>B</sub> The receive buffer is not full.</p> <p>1<sub>B</sub> The receive buffer is full.</p>
<b>RBUS</b>	5	rh	<p><b>Receive Buffer Busy</b></p> <p>This bit indicates whether the receive buffer is currently updated by the FIFO handler.</p> <p>0<sub>B</sub> The receive buffer information has been completely updated.</p> <p>1<sub>B</sub> The <code>OUTR</code> update from the FIFO memory is ongoing. A read from <code>OUTR</code> will be delayed. FIFO pointers from the previous read are not yet updated.</p>
<b>SRBT</b>	6	rh	<p><b>Standard Receive Buffer Event Trigger</b></p> <p>This bit triggers a standard receive buffer event when set.</p> <p>If enabled by <code>RBCTR.SRBIEN</code>, the service request output <code>SRx</code> selected by <code>RBCTR.SRBINP</code> becomes activated until the bit is cleared.</p> <p>0<sub>B</sub> A standard receive buffer event is not triggered using this bit.</p> <p>1<sub>B</sub> A standard receive buffer event is triggered using this bit.</p>

**Universal Serial Interface Channel (USIC)**

<b>Field</b>	<b>Bits</b>	<b>Type</b>	<b>Description</b>
<b>STBI</b>	8	rwh	<p><b>Standard Transmit Buffer Event</b></p> <p>This bit indicates that a standard transmit buffer event has been detected. It is cleared by writing <math>TRBSCR.CSTBI = 1</math>.</p> <p>If enabled by <math>TBCTR.STBIEN</math>, the service request output <math>SRx</math> selected by <math>TBCTR.STBINP</math> becomes activated if a standard transmit buffer event is detected.</p> <p><math>0_B</math> A standard transmit buffer event has not been detected.</p> <p><math>1_B</math> A standard transmit buffer event has been detected.</p>
<b>TBERI</b>	9	rwh	<p><b>Transmit Buffer Error Event</b></p> <p>This bit indicates that a transmit buffer error event has been detected. It is cleared by writing <math>TRBSCR.CTBERI = 1</math>.</p> <p>If enabled by <math>TBCTR.TBERIEN</math>, the service request output <math>SRx</math> selected by <math>TBCTR.ATBINP</math> becomes activated if a transmit buffer error event is detected.</p> <p><math>0_B</math> A transmit buffer error event has not been detected.</p> <p><math>1_B</math> A transmit buffer error event has been detected.</p>
<b>EMPTY</b>	11	rh	<p><b>Transmit Buffer Empty</b></p> <p>This bit indicates whether the transmit buffer is empty.</p> <p><math>0_B</math> The transmit buffer is not empty.</p> <p><math>1_B</math> The transmit buffer is empty.</p>
<b>TFULL</b>	12	rh	<p><b>Transmit Buffer Full</b></p> <p>This bit indicates whether the transmit buffer is full.</p> <p><math>0_B</math> The transmit buffer is not full.</p> <p><math>1_B</math> The transmit buffer is full.</p>

**Universal Serial Interface Channel (USIC)**

<b>Field</b>	<b>Bits</b>	<b>Type</b>	<b>Description</b>
<b>TBUS</b>	13	rh	<p><b>Transmit Buffer Busy</b> This bit indicates whether the transmit buffer is currently updated by the FIFO handler.</p> <p>0<sub>B</sub> The transmit buffer information has been completely updated.</p> <p>1<sub>B</sub> The FIFO memory update after write to INx is ongoing. A write to INx will be delayed. FIFO pointers from the previous INx write are not yet updated.</p>
<b>STBT</b>	14	rh	<p><b>Standard Transmit Buffer Event Trigger</b> This bit triggers a standard transmit buffer event when set.</p> <p>If enabled by TBCTR.STBIEN, the service request output SRx selected by TBCTR.STBINP becomes activated until the bit is cleared.</p> <p>0<sub>B</sub> A standard transmit buffer event is not triggered using this bit.</p> <p>1<sub>B</sub> A standard transmit buffer event is triggered using this bit.</p>
<b>RBFLVL</b>	[22:16]	rh	<p><b>Receive Buffer Filling Level</b> This bit field indicates the filling level of the receive buffer, starting with 0 for an empty buffer.</p>
<b>TBFLVL</b>	[30:24]	rh	<p><b>Transmit Buffer Filling Level</b> This bit field indicates the filling level of the transmit buffer, starting with 0 for an empty buffer.</p>
<b>0</b>	7, 10, 15, 23, 31	r	<p><b>Reserved</b> Read as 0; should be written with 0.</p>



**Universal Serial Interface Channel (USIC)**

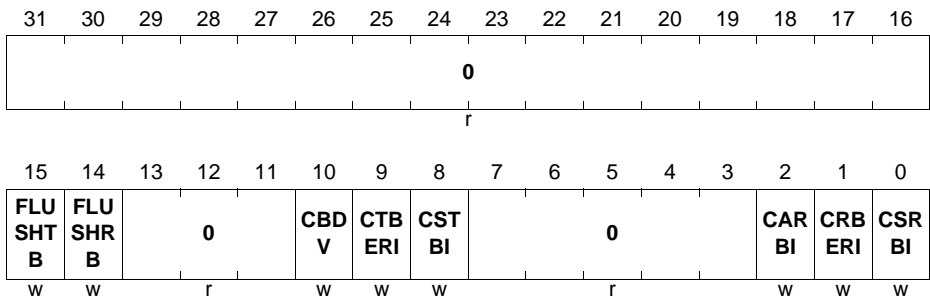
The bits in register TRBSCR are used to clear the notification bits in register TRBSR or to clear the FIFO mechanism for the transmit or receive buffer. A read action always delivers 0.

**TRBSCR**

**Transmit/Receive Buffer Status Clear Register**

(118<sub>H</sub>)

Reset Value: 0000 0000<sub>H</sub>



Field	Bits	Type	Description
<b>CSRBI</b>	0	w	<b>Clear Standard Receive Buffer Event</b> 0 <sub>B</sub> No effect. 1 <sub>B</sub> Clear TRBSR.SRBI.
<b>CRBERI</b>	1	w	<b>Clear Receive Buffer Error Event</b> 0 <sub>B</sub> No effect. 1 <sub>B</sub> Clear TRBSR.RBERI.
<b>CARBI</b>	2	w	<b>Clear Alternative Receive Buffer Event</b> 0 <sub>B</sub> No effect. 1 <sub>B</sub> Clear TRBSR.ARBI.
<b>CSTBI</b>	8	w	<b>Clear Standard Transmit Buffer Event</b> 0 <sub>B</sub> No effect. 1 <sub>B</sub> Clear TRBSR.STBI.
<b>CTBERI</b>	9	w	<b>Clear Transmit Buffer Error Event</b> 0 <sub>B</sub> No effect. 1 <sub>B</sub> Clear TRBSR.TBERI.
<b>CBDV</b>	10	w	<b>Clear Bypass Data Valid</b> 0 <sub>B</sub> No effect. 1 <sub>B</sub> Clear BYPCR.BDV.

**Universal Serial Interface Channel (USIC)**

Field	Bits	Type	Description
<b>FLUSHRB</b>	14	w	<b>Flush Receive Buffer</b> $0_B$ No effect. $1_B$ The receive FIFO buffer is cleared (filling level is cleared and output pointer is set to input pointer value). Should only be used while the FIFO buffer is not taking part in data traffic.
<b>FLUSHTB</b>	15	w	<b>Flush Transmit Buffer</b> $0_B$ No effect. $1_B$ The transmit FIFO buffer is cleared (filling level is cleared and output pointer is set to input pointer value). Should only be used while the FIFO buffer is not taking part in data traffic.
<b>0</b>	[7:3], [13:11], [31:16]	r	<b>Reserved</b> Read as 0; should be written with 0.

### 15.11.9.3 Transmit FIFO Buffer Control Registers

The transmit FIFO buffer is controlled by register TBCTR. TBCTR can only be written if the transmit buffer functionality is enabled by CCFG.TB = 1, otherwise write accesses are ignored.

#### TBCTR

**Transmitter Buffer Control Register (108<sub>H</sub>)**

**Reset Value: 0000 0000<sub>H</sub>**

31	30	29	28	27	26	25	24	23	22	21	20	19	18	17	16
<b>TBE RIEN</b>	<b>STBI EN</b>	<b>0</b>	<b>LOF</b>	<b>0</b>	<b>SIZE</b>			<b>0</b>	<b>ATBINP</b>			<b>STBINP</b>			
r/w	r/w	r	r/w	r	r/w			r	r/w			r/w			
15	14	13	12	11	10	9	8	7	6	5	4	3	2	1	0
<b>STB TEN</b>	<b>STB TM</b>	<b>LIMIT</b>					<b>0</b>	<b>DPTR</b>							
r/w	r/w	r/w					r	w							

**Universal Serial Interface Channel (USIC)**

<b>Field</b>	<b>Bits</b>	<b>Type</b>	<b>Description</b>
<b>DPTR</b>	[5:0]	w	<p><b>Data Pointer</b></p> <p>This bit field defines the start value for the transmit buffer pointers when assigning the FIFO entries to the transmit FIFO buffer. A read always delivers 0. When writing DPTR while SIZE = 0, both transmitter pointers TDIPTR and RTDOPTR in register TRBPTR are updated with the written value and the buffer is considered as empty. A write access to DPTR while SIZE &gt; 0 is ignored and does not modify the pointers.</p>
<b>LIMIT</b>	[13:8]	rw	<p><b>Limit For Interrupt Generation</b></p> <p>This bit field defines the target filling level of the transmit FIFO buffer that is used for the standard transmit buffer event detection.</p>
<b>STBTM</b>	14	rw	<p><b>Standard Transmit Buffer Trigger Mode</b></p> <p>This bit selects the standard transmit buffer event trigger mode.</p> <p>0<sub>B</sub> Trigger mode 0: While TRBSR.STBT=1, a standard buffer event will be generated whenever there is a data transfer to TBUF or data write to INx (depending on TBCTR.LOF setting). STBT is cleared when TRBSR.TBFLVL=TBCTR.LIMIT.</p> <p>1<sub>B</sub> Trigger mode 1: While TRBSR.STBT=1, a standard buffer event will be generated whenever there is a data transfer to TBUF or data write to INx (depending on TBCTR.LOF setting). STBT is cleared when TRBSR.TBFLVL=TBCTR.SIZE.</p>
<b>STBTEN</b>	15	rw	<p><b>Standard Transmit Buffer Trigger Enable</b></p> <p>This bit enables/disables triggering of the standard transmit buffer event through bit TRBSR.STBT.</p> <p>0<sub>B</sub> The standard transmit buffer event trigger through bit TRBSR.STBT is disabled.</p> <p>1<sub>B</sub> The standard transmit buffer event trigger through bit TRBSR.STBT is enabled.</p>

**Universal Serial Interface Channel (USIC)**

<b>Field</b>	<b>Bits</b>	<b>Type</b>	<b>Description</b>
<b>STBINP</b>	[18:16]	rw	<p><b>Standard Transmit Buffer Interrupt Node Pointer</b></p> <p>This bit field defines which service request output SRx becomes activated in case of a standard transmit buffer event.</p> <p>000<sub>B</sub> Output SR0 becomes activated.            001<sub>B</sub> Output SR1 becomes activated.            010<sub>B</sub> Output SR2 becomes activated.            011<sub>B</sub> Output SR3 becomes activated.            100<sub>B</sub> Output SR4 becomes activated.            101<sub>B</sub> Output SR5 becomes activated.</p> <p><i>Note: All other settings of the bit field are reserved.</i></p>
<b>ATBINP</b>	[21:19]	rw	<p><b>Alternative Transmit Buffer Interrupt Node Pointer</b></p> <p>This bit field define which service request output SRx will be activated in case of a transmit buffer error event.</p> <p>000<sub>B</sub> Output SR0 becomes activated.            001<sub>B</sub> Output SR1 becomes activated.            010<sub>B</sub> Output SR2 becomes activated.            011<sub>B</sub> Output SR3 becomes activated.            100<sub>B</sub> Output SR4 becomes activated.            101<sub>B</sub> Output SR5 becomes activated.</p> <p><i>Note: All other settings of the bit field are reserved.</i></p>
<b>SIZE</b>	[26:24]	rw	<p><b>Buffer Size</b></p> <p>This bit field defines the number of FIFO entries assigned to the transmit FIFO buffer.</p> <p>000<sub>B</sub> The FIFO mechanism is disabled. The buffer does not accept any request for data.            001<sub>B</sub> The FIFO buffer contains 2 entries.            010<sub>B</sub> The FIFO buffer contains 4 entries.            011<sub>B</sub> The FIFO buffer contains 8 entries.            100<sub>B</sub> The FIFO buffer contains 16 entries.            101<sub>B</sub> The FIFO buffer contains 32 entries.            110<sub>B</sub> The FIFO buffer contains 64 entries.            111<sub>B</sub> Reserved</p>

**Universal Serial Interface Channel (USIC)**

<b>Field</b>	<b>Bits</b>	<b>Type</b>	<b>Description</b>
<b>LOF</b>	28	rw	<p><b>Buffer Event on Limit Overflow</b> This bit defines which relation between filling level and programmed limit leads to a standard transmit buffer event.</p> <p>0<sub>B</sub> A standard transmit buffer event occurs when the filling level equals the limit value and gets lower due to transmission of a data word.</p> <p>1<sub>B</sub> A standard transmit buffer interrupt event occurs when the filling level equals the limit value and gets bigger due to a write access to a data input location INx.</p>
<b>STBIEN</b>	30	rw	<p><b>Standard Transmit Buffer Interrupt Enable</b> This bit enables/disables the generation of a standard transmit buffer interrupt in case of a standard transmit buffer event.</p> <p>0<sub>B</sub> The standard transmit buffer interrupt generation is disabled.</p> <p>1<sub>B</sub> The standard transmit buffer interrupt generation is enabled.</p>
<b>TBERIEN</b>	31	rw	<p><b>Transmit Buffer Error Interrupt Enable</b> This bit enables/disables the generation of a transmit buffer error interrupt in case of a transmit buffer error event (software writes to a full transmit buffer).</p> <p>0<sub>B</sub> The transmit buffer error interrupt generation is disabled.</p> <p>1<sub>B</sub> The transmit buffer error interrupt generation is enabled.</p>
<b>0</b>	[7:6], [23:22], 27, 29	r	<p><b>Reserved</b> Read as 0; should be written with 0.</p>

**Universal Serial Interface Channel (USIC)**

**15.11.9.4 Receive FIFO Buffer Control Registers**

The receive FIFO buffer is controlled by register RBCTR. This register can only be written if the receive buffer functionality is enabled by CCFG.RB = 1, otherwise write accesses are ignored.

**RBCTR**

**Receiver Buffer Control Register (10C<sub>H</sub>)** **Reset Value: 0000 0000<sub>H</sub>**

31	30	29	28	27	26	25	24	23	22	21	20	19	18	17	16	
<b>RBE RIEN</b>	<b>SRBI EN</b>	<b>ARBI EN</b>	<b>LOF</b>	<b>RNM</b>	<b>SIZE</b>			<b>RCIM</b>			<b>ARBINP</b>			<b>SRBINP</b>		
rw	rw	rw	rw	rw	rw			rw			rw			rw		
15	14	13	12	11	10	9	8	7	6	5	4	3	2	1	0	
<b>SRB TEN</b>	<b>SRB TM</b>	<b>LIMIT</b>				<b>0</b>			<b>DPTR</b>							
rw	rw	rw				r			w							

Field	Bits	Type	Description
<b>DPTR</b>	[5:0]	w	<p><b>Data Pointer</b></p> <p>This bit field defines the start value for the receive buffer pointers when assigning the FIFO entries to the receive FIFO buffer. A read always delivers 0. When writing DPTR while SIZE = 0, both receiver pointers RDIPTR and RDOPTR in register TRBPTR are updated with the written value and the buffer is considered as empty. A write access to DPTR while SIZE &gt; 0 is ignored and does not modify the pointers.</p>
<b>LIMIT</b>	[13:8]	rw	<p><b>Limit For Interrupt Generation</b></p> <p>This bit field defines the target filling level of the receive FIFO buffer that is used for the standard receive buffer event detection.</p>

**Universal Serial Interface Channel (USIC)**

Field	Bits	Type	Description
<b>SRBTM</b>	14	rw	<p><b>Standard Receive Buffer Trigger Mode</b> This bit selects the standard receive buffer event trigger mode.</p> <p>0<sub>B</sub> Trigger mode 0: While TRBSR.SRBT=1, a standard receive buffer event will be generated whenever there is a new data received or data read out (depending on RBCTR.LOF setting). SRBT is cleared when TRBSR.RBFLVL=RBCTR.LIMIT.</p> <p>1<sub>B</sub> Trigger mode 1: While TRBSR.SRBT=1, a standard receive buffer event will be generated whenever there is a new data received or data read out (depending on RBCTR.LOF setting). SRBT is cleared when TRBSR.RBFLVL=0.</p>
<b>SRBTEN</b>	15	rw	<p><b>Standard Receive Buffer Trigger Enable</b> This bit enables/disables triggering of the standard receive buffer event through bit TRBSR.SRBT.</p> <p>0<sub>B</sub> The standard receive buffer event trigger through bit TRBSR.SRBT is disabled.</p> <p>1<sub>B</sub> The standard receive buffer event trigger through bit TRBSR.SRBT is enabled.</p>
<b>SRBINP</b>	[18:16]	rw	<p><b>Standard Receive Buffer Interrupt Node Pointer</b> This bit field defines which service request output SRx becomes activated in case of a standard receive buffer event.</p> <p>000<sub>B</sub> Output SR0 becomes activated. 001<sub>B</sub> Output SR1 becomes activated. 010<sub>B</sub> Output SR2 becomes activated. 011<sub>B</sub> Output SR3 becomes activated. 100<sub>B</sub> Output SR4 becomes activated. 101<sub>B</sub> Output SR5 becomes activated.</p> <p><i>Note: All other settings of the bit field are reserved.</i></p>

**Universal Serial Interface Channel (USIC)**

<b>Field</b>	<b>Bits</b>	<b>Type</b>	<b>Description</b>
<b>ARBINP</b>	[21:19]	rw	<p><b>Alternative Receive Buffer Interrupt Node Pointer</b></p> <p>This bit field defines which service request output SR<sub>x</sub> becomes activated in case of an alternative receive buffer event or a receive buffer error event.</p> <p>000<sub>B</sub> Output SR0 becomes activated.            001<sub>B</sub> Output SR1 becomes activated.            010<sub>B</sub> Output SR2 becomes activated.            011<sub>B</sub> Output SR3 becomes activated.            100<sub>B</sub> Output SR4 becomes activated.            101<sub>B</sub> Output SR5 becomes activated.</p> <p><i>Note: All other settings of the bit field are reserved.</i></p>
<b>RCIM</b>	[23:22]	rw	<p><b>Receiver Control Information Mode</b></p> <p>This bit field defines which information from the receiver status register RBUFSR is propagated as 5 bit receiver control information RCI[4:0] to the receive FIFO buffer and can be read out in registers OUT(D)R.</p> <p>00<sub>B</sub> RCI[4] = PERR, RCI[3:0] = WLEN            01<sub>B</sub> RCI[4] = SOF, RCI[3:0] = WLEN            10<sub>B</sub> RCI[4] = 0, RCI[3:0] = WLEN            11<sub>B</sub> RCI[4] = PERR, RCI[3] = PAR,            RCI[2:1] = 00<sub>B</sub>, RCI[0] = SOF</p>
<b>SIZE</b>	[26:24]	rw	<p><b>Buffer Size</b></p> <p>This bit field defines the number of FIFO entries assigned to the receive FIFO buffer.</p> <p>000<sub>B</sub> The FIFO mechanism is disabled. The buffer does not accept any request for data.            001<sub>B</sub> The FIFO buffer contains 2 entries.            010<sub>B</sub> The FIFO buffer contains 4 entries.            011<sub>B</sub> The FIFO buffer contains 8 entries.            100<sub>B</sub> The FIFO buffer contains 16 entries.            101<sub>B</sub> The FIFO buffer contains 32 entries.            110<sub>B</sub> The FIFO buffer contains 64 entries.            111<sub>B</sub> Reserved</p>



**Universal Serial Interface Channel (USIC)**

Field	Bits	Type	Description
<b>RNM</b>	27	rw	<p><b>Receiver Notification Mode</b></p> <p>This bit defines the receive buffer event mode. The receive buffer error event is not affected by RNM.</p> <p>0<sub>B</sub> Filling level mode: A standard receive buffer event occurs when the filling level equals the limit value and changes, either due to a read access from OTR (LOF = 0) or due to a new received data word (LOF = 1).</p> <p>1<sub>B</sub> RCI mode: A standard receive buffer event occurs when register OTR is updated with a new value if the corresponding value in OTR.RCI[4] = 0. If OTR.RCI[4] = 1, an alternative receive buffer event occurs instead of the standard receive buffer event.</p>
<b>LOF</b>	28	rw	<p><b>Buffer Event on Limit Overflow</b></p> <p>This bit defines which relation between filling level and programmed limit leads to a standard receive buffer event in filling level mode (RNM = 0). In RCI mode (RNM = 1), bit fields LIMIT and LOF are ignored.</p> <p>0<sub>B</sub> A standard receive buffer event occurs when the filling level equals the limit value and gets lower due to a read access from OTR.</p> <p>1<sub>B</sub> A standard receive buffer event occurs when the filling level equals the limit value and gets bigger due to the reception of a new data word.</p>
<b>ARBIEN</b>	29	rw	<p><b>Alternative Receive Buffer Interrupt Enable</b></p> <p>This bit enables/disables the generation of an alternative receive buffer interrupt in case of an alternative receive buffer event.</p> <p>0<sub>B</sub> The alternative receive buffer interrupt generation is disabled.</p> <p>1<sub>B</sub> The alternative receive buffer interrupt generation is enabled.</p>

**Universal Serial Interface Channel (USIC)**

Field	Bits	Type	Description
<b>SRBIEN</b>	30	rw	<p><b>Standard Receive Buffer Interrupt Enable</b> This bit enables/disables the generation of a standard receive buffer interrupt in case of a standard receive buffer event.</p> <p>0<sub>B</sub> The standard receive buffer interrupt generation is disabled.</p> <p>1<sub>B</sub> The standard receive buffer interrupt generation is enabled.</p>
<b>RBERIEN</b>	31	rw	<p><b>Receive Buffer Error Interrupt Enable</b> This bit enables/disables the generation of a receive buffer error interrupt in case of a receive buffer error event (the software reads from an empty receive buffer).</p> <p>0<sub>B</sub> The receive buffer error interrupt generation is disabled.</p> <p>1<sub>B</sub> The receive buffer error interrupt generation is enabled.</p>
<b>0</b>	[7:6]	r	<p><b>Reserved</b> Read as 0; should be written with 0.</p>

**Universal Serial Interface Channel (USIC)**

**15.11.9.5 FIFO Buffer Data Registers**

The 32 independent data input locations IN00 to IN31 are addresses that can be used as data entry locations for the transmit FIFO buffer. Data written to one of these locations will be stored in the transmit buffer FIFO. Additionally, the 5-bit coding of the number [31:0] of the addressed data input location represents the transmit control information TCI.

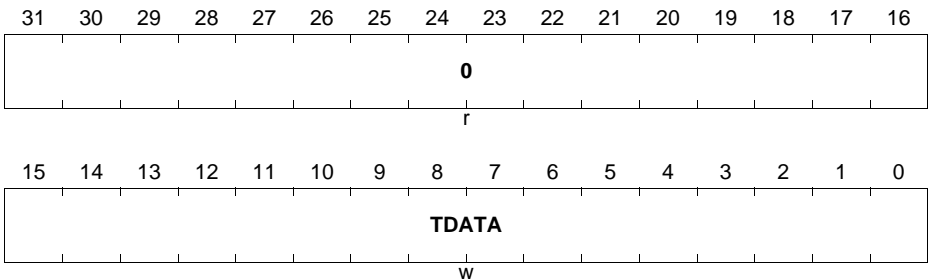
If the FIFO is already full and new data is written to it, the write access is ignored and a transmit buffer error event is signaled.

**IN<sub>x</sub> (x = 00-31)**

**Transmit FIFO Buffer Input Location x**

$$(180_H + x * 4)$$

**Reset Value: 0000 0000<sub>H</sub>**



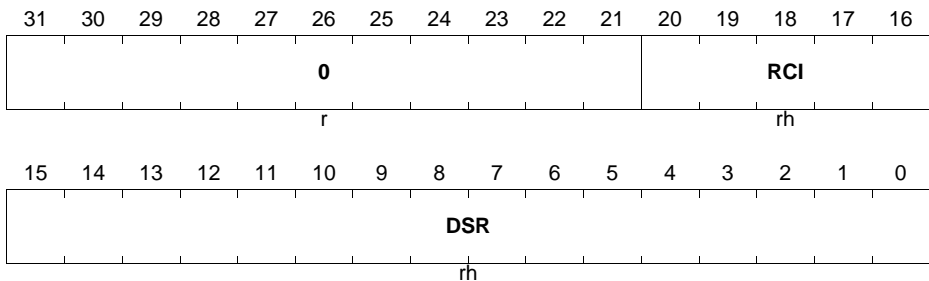
Field	Bits	Type	Description
TDATA	[15:0]	w	<b>Transmit Data</b> This bit field contains the data to be transmitted (write view), read actions deliver 0. A write action to at least the low byte of TDATA triggers the data storage in the FIFO.
0	[31:16]	r	<b>Reserved</b> Read as 0; should be written with 0.

**Universal Serial Interface Channel (USIC)**

The receiver FIFO buffer output register OUTR shows the oldest received data word in the FIFO buffer and contains the receiver control information RCI containing the information selected by RBCTR.RCIM. A read action from this address location delivers the received data. With a read access of at least the low byte, the data is declared to be read and the next entry becomes visible. Write accesses to OUTR are ignored.

**OUTR**

**Receiver Buffer Output Register (11C<sub>H</sub>)**      **Reset Value: 0000 0000<sub>H</sub>**



Field	Bits	Type	Description
<b>DSR</b>	[15:0]	rh	<b>Received Data</b> This bit field monitors the content of the oldest data word in the receive FIFO. Reading at least the low byte releases the buffer entry currently shown in DSR.
<b>RCI</b>	[20:16]	rh	<b>Receiver Control Information</b> This bit field monitors the receiver control information associated to DSR. The bit structure of RCI depends on bit field RBCTR.RCIM.
<b>0</b>	[31:21]	r	<b>Reserved</b> Read as 0; should be written with 0.

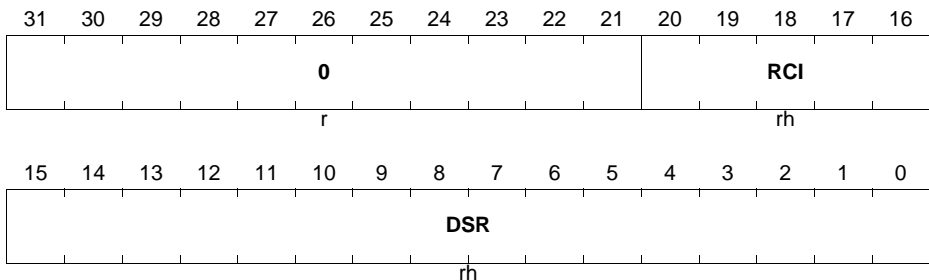
**Universal Serial Interface Channel (USIC)**

If a debugger should be used to monitor the received data in the FIFO buffer, the FIFO mechanism must not be activated in order to guaranty data consistency. Therefore, a second address set is available, named OUTDR (D like debugger), having the same bit fields like the original buffer output register OUTR, but without the FIFO mechanism. A debugger can read here (in order to monitor the receive data flow) without the risk of data corruption. Write accesses to OUTDR are ignored.

**OUTDR**

**Receiver Buffer Output Register L for Debugger**  
**(120<sub>H</sub>)**

**Reset Value: 0000 0000<sub>H</sub>**



Field	Bits	Type	Description
DSR	[15:0]	rh	<b>Data from Shift Register</b> Same as OUTR.DSR, but without releasing the buffer after a read action.
RCI	[20:16]	rh	<b>Receive Control Information from Shift Register</b> Same as OUTR.RCI.
0	[31:21]	r	<b>Reserved</b> Read as 0; should be written with 0.

**Universal Serial Interface Channel (USIC)**

**15.11.9.6 FIFO Buffer Pointer Registers**

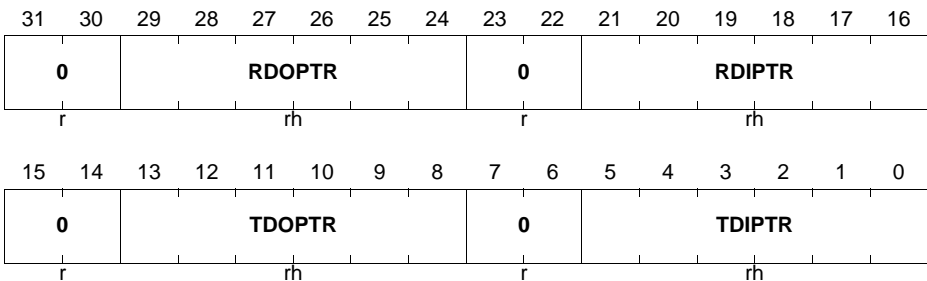
The pointers for FIFO handling of the transmit and receive FIFO buffers are located in register TRBPTR. The pointers are automatically handled by the FIFO buffer mechanism and do not need to be modified by software. As a consequence, these registers can only be read by software (e.g. for verification purposes), whereas write accesses are ignored.

**TRBPTR**

**Transmit/Receive Buffer Pointer Register**

(110<sub>H</sub>)

Reset Value: 0000 0000<sub>H</sub>

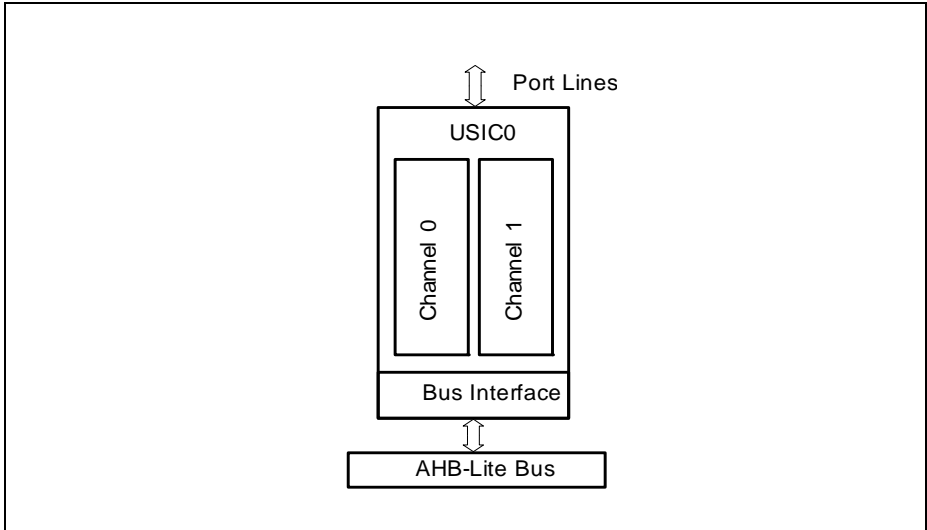


Field	Bits	Type	Description
<b>TDIPTTR</b>	[5:0]	rh	<b>Transmitter Data Input Pointer</b> This bit field indicates the buffer entry that will be used for the next transmit data coming from the INx addresses.
<b>TDOPTR</b>	[13:8]	rh	<b>Transmitter Data Output Pointer</b> This bit field indicates the buffer entry that will be used for the next transmit data to be output to TBUF.
<b>RDIPTTR</b>	[21:16]	rh	<b>Receiver Data Input Pointer</b> This bit field indicates the buffer entry that will be used for the next receive data coming from RBUF.
<b>RDOPTR</b>	[29:24]	rh	<b>Receiver Data Output Pointer</b> This bit field indicates the buffer entry that will be used for the next receive data to be output at the OUT(D)R addresses.
<b>0</b>	[7:6], [15:14], [23:22], [31:30]	r	<b>Reserved</b> Read as 0; should be written with 0.

**Universal Serial Interface Channel (USIC)**

**15.12 Interconnects**

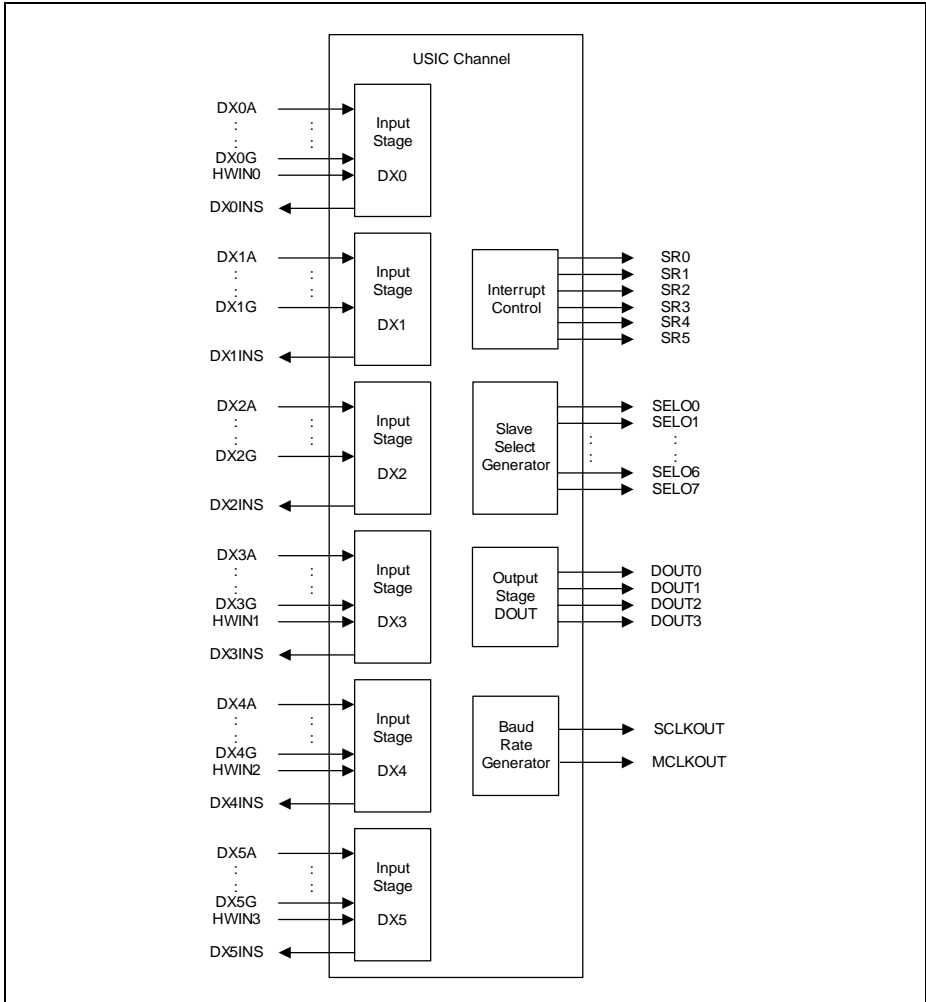
The XMC1200 device contains one USIC module (USIC0) with 2 communication channels.



**Figure 15-66 USIC Module Structure in XMC1200**

**Figure 15-67** shows the I/O lines of one USIC channel. The tables in this section define the pin assignments and internal connections of the USIC channels I/O lines in the XMC1200 device. Naming convention: USICx\_CHy refers to USIC module x channel y.

**Universal Serial Interface Channel (USIC)**



**Figure 15-67 USIC Channel I/O Lines**

The service request outputs SR[5:0] of one USIC channel is combined with those of the other channel within the module. Therefore, only 6 service request outputs are available per module.

### 15.12.1 USIC Module 0 Interconnects

The interconnects of USIC module 0 is grouped into the following categories:



**Universal Serial Interface Channel (USIC)**

- **USIC Module 0 Channel 0 Interconnects (Table 15-22)**
- **USIC Module 0 Channel 1 Interconnects (Table 15-23)**
- **USIC Module 0 Module Interconnects (Table 15-24)**

**Table 15-22 USIC Module 0 Channel 0 Interconnects**

<b>Input/Output</b>	<b>I/O</b>	<b>Connected To</b>	<b>Description</b>
<b>Data Inputs (DX0)</b>			
USIC0_CH0.DX0A	I	P0.14	Shift data input
USIC0_CH0.DX0B	I	P0.15	Shift data input
USIC0_CH0.DX0C	I	P1.0	Shift data input
USIC0_CH0.DX0D	I	P1.1	Shift data input
USIC0_CH0.DX0E	I	P2.0	Shift data input
USIC0_CH0.DX0F	I	P2.1	Shift data input
USIC0_CH0.DX0G	I	USIC0_CH0.DX3INS	Shift data input
USIC0_CH0.HWIN0	I	P1.0	HW controlled shift data input
<b>Clock Inputs</b>			
USIC0_CH0.DX1A	I	P0.14	Shift clock input
USIC0_CH0.DX1B	I	P0.8	Shift clock input
USIC0_CH0.DX1C	I	P0.7	Shift clock input
USIC0_CH0.DX1D	I	P1.1	Shift clock input
USIC0_CH0.DX1E	I	P2.0	Shift clock input
USIC0_CH0.DX1F	I	USIC0_CH0.DX0INS	Shift clock input
USIC0_CH0.DX1G	I	USIC0_CH0.DX4INS	Loop back shift clock input
<b>Control Inputs</b>			
USIC0_CH0.DX2A	I	P0.0	Shift control input
USIC0_CH0.DX2B	I	P0.9	Shift control input
USIC0_CH0.DX2C	I	P0.10	Shift control input
USIC0_CH0.DX2D	I	P0.11	Shift control input
USIC0_CH0.DX2E	I	P0.12	Shift control input
USIC0_CH0.DX2F	I	P0.13	Shift control input
USIC0_CH0.DX2G	I	USIC0_CH0.DX5INS	Loop back shift control input
<b>Data Inputs (DX3)</b>			
USIC0_CH0.DX3A	I	P2.2	Shift data input

**Universal Serial Interface Channel (USIC)**

**Table 15-22 USIC Module 0 Channel 0 Interconnects (cont'd)**

<b>Input/Output</b>	<b>I/O</b>	<b>Connected To</b>	<b>Description</b>
USIC0_CH0.DX3B	I	P2.4	Shift data input
USIC0_CH0.DX3C	I	P2.10	Shift data input
USIC0_CH0.DX3D	I	P2.8	Shift data input
USIC0_CH0.DX3E	I	P2.6	Shift data input
USIC0_CH0.DX3F	I	USIC0_CH0.DX5INS	Shift data input
USIC0_CH0.DX3G	I	USIC0_CH0.DOUT0	Shift data input
USIC0_CH0.HWIN1	I	P1.1	HW controlled shift data input
<b>Data Inputs (DX4)</b>			
USIC0_CH0.DX4A	I	P2.2	Shift data input
USIC0_CH0.DX4B	I	P2.4	Shift data input
USIC0_CH0.DX4C	I	P2.10	Shift data input
USIC0_CH0.DX4D	I	P2.8	Shift data input
USIC0_CH0.DX4E	I	P2.6	Shift data input
USIC0_CH0.DX4F	I	USIC0_CH0.DX5INS	Shift data input
USIC0_CH0.DX4G	I	USIC0_CH0.SCLKOUT	Shift data input
USIC0_CH0.HWIN2	I	P1.2	HW controlled shift data input
<b>Data Inputs (DX5)</b>			
USIC0_CH0.DX5A	I	P2.9	Shift data input
USIC0_CH0.DX5B	I	P2.3	Shift data input
USIC0_CH0.DX5C	I	P2.7	Shift data input
USIC0_CH0.DX5D	I	P2.5	Shift data input
USIC0_CH0.DX5E	I	P1.4	Shift data input
USIC0_CH0.DX5F	I	0	Shift data input
USIC0_CH0.DX5G	I	USIC0_CH0.SELO0	Shift data input
USIC0_CH0.HWIN3	I	P1.3	HW controlled shift data input
<b>Data Outputs</b>			

**Universal Serial Interface Channel (USIC)**

**Table 15-22 USIC Module 0 Channel 0 Interconnects (cont'd)**

<b>Input/Output</b>	<b>I/O</b>	<b>Connected To</b>	<b>Description</b>
USIC0_CH0.DOUT0	O	P0.14 P0.15 P1.0 P1.0 (HW1_OUT) P1.1 P1.5 P2.0 P2.1 USIC0_CH0.DX3G	Shift data output
USIC0_CH0.DOUT1	O	P1.1 (HW1_OUT)	Shift data output
USIC0_CH0.DOUT2	O	P1.2 (HW1_OUT)	Shift data output
USIC0_CH0.DOUT3	O	P1.3 (HW1_OUT)	Shift data output
<b>Clock Outputs</b>			
USIC0_CH0.MCLKOUT	O	P0.11	Master clock output
USIC0_CH0.SCLKOUT	O	P0.7 P0.8 P0.14 P2.0 USIC0_CH0.DX4G	Shift clock output
<b>Control Outputs</b>			
USIC0_CH0.SELO0	O	P0.0 P0.9 P1.4 USIC0_CH0.DX5G	Shift control output
USIC0_CH0.SELO1	O	P0.10 P1.5	Shift control output
USIC0_CH0.SELO2	O	P0.11	Shift control output
USIC0_CH0.SELO3	O	P0.12	Shift control output
USIC0_CH0.SELO4	O	P0.13	Shift control output
USIC0_CH0.SELO5	O	not connected	Shift control output
USIC0_CH0.SELO6	O	not connected	Shift control output
USIC0_CH0.SELO7	O	not connected	Shift control output
<b>System Related Outputs</b>			
USIC0_CH0.DX0INS	O	USIC0_CH0.DX1F	Selected DX0 input signal

**Universal Serial Interface Channel (USIC)**

**Table 15-22 USIC Module 0 Channel 0 Interconnects (cont'd)**

Input/Output	I/O	Connected To	Description
USIC0_CH0.DX1INS	O	not connected	Selected DX1 input signal
USIC0_CH0.DX2INS	O	CCU40.IN0L	Selected DX2 input signal
USIC0_CH0.DX3INS	O	USIC0_CH0.DX0G	Selected DX3 input signal
USIC0_CH0.DX4INS	O	USIC0_CH0.DX1G	Selected DX4 input signal
USIC0_CH0.DX5INS	O	USIC0_CH0.DX2G USIC0_CH0.DX3F USIC0_CH0.DX4F	Selected DX5 input signal

**Table 15-23 USIC Module 0 Channel 1 Interconnects**

Input/Output	I/O	Connected To	Description
<b>Data Inputs (DX0)</b>			
USIC0_CH1.DX0A	I	P1.3	Shift data input
USIC0_CH1.DX0B	I	P1.2	Shift data input
USIC0_CH1.DX0C	I	P0.6	Shift data input
USIC0_CH1.DX0D	I	P0.7	Shift data input
USIC0_CH1.DX0E	I	P2.11	Shift data input
USIC0_CH1.DX0F	I	P2.10	Shift data input
USIC0_CH1.DX0G	I	USIC0_CH1.DX3INS	Shift data input
USIC0_CH1.HWIN0	I	ERU0.PDOUT0	HW controlled shift data input
<b>Clock Inputs</b>			
USIC0_CH1.DX1A	I	P1.3	Shift clock input
USIC0_CH1.DX1B	I	P0.8	Shift clock input
USIC0_CH1.DX1C	I	P0.7	Shift clock input
USIC0_CH1.DX1D	I	0	Shift clock input
USIC0_CH1.DX1E	I	P2.11	Shift clock input
USIC0_CH1.DX1F	I	USIC0_CH1.DX0INS	Shift clock input
USIC0_CH1.DX1G	I	USIC0_CH1.DX4INS	Loop back shift clock input
<b>Control Inputs</b>			
USIC0_CH1.DX2A	I	P0.0	Shift control input
USIC0_CH1.DX2B	I	P0.9	Shift control input
USIC0_CH1.DX2C	I	P0.10	Shift control input

**Universal Serial Interface Channel (USIC)**

**Table 15-23 USIC Module 0 Channel 1 Interconnects (cont'd)**

<b>Input/Output</b>	<b>I/O</b>	<b>Connected To</b>	<b>Description</b>
USIC0_CH1.DX2D	I	P0.11	Shift control input
USIC0_CH1.DX2E	I	P1.1	Shift control input
USIC0_CH1.DX2F	I	P2.0	Shift control input
USIC0_CH1.DX2G	I	USIC0_CH1.DX5INS	Loop back shift control input
<b>Data Inputs (DX3)</b>			
USIC0_CH1.DX3A	I	P2.1	Shift data input
USIC0_CH1.DX3B	I	P2.9	Shift data input
USIC0_CH1.DX3C	I	P2.3	Shift data input
USIC0_CH1.DX3D	I	P2.7	Shift data input
USIC0_CH1.DX3E	I	P2.5	Shift data input
USIC0_CH1.DX3F	I	USIC0_CH1.DX5INS	Shift data input
USIC0_CH1.DX3G	I	USIC0_CH1.DOUT0	Shift data input
USIC0_CH1.HWIN1	I	0	HW controlled shift data input
<b>Data Inputs (DX4)</b>			
USIC0_CH1.DX4A	I	P2.1	Shift data input
USIC0_CH1.DX4B	I	P2.9	Shift data input
USIC0_CH1.DX4C	I	P2.3	Shift data input
USIC0_CH1.DX4D	I	P2.7	Shift data input
USIC0_CH1.DX4E	I	P2.5	Shift data input
USIC0_CH1.DX4F	I	USIC0_CH1.DX5INS	Shift data input
USIC0_CH1.DX4G	I	USIC0_CH1.SCLKOUT	Shift data input
USIC0_CH1.HWIN2	I	ERU0.PDOUT1	HW controlled shift data input
<b>Data Inputs (DX5)</b>			
USIC0_CH1.DX5A	I	P2.2	Shift data input
USIC0_CH1.DX5B	I	P2.4	Shift data input
USIC0_CH1.DX5C	I	P2.8	Shift data input
USIC0_CH1.DX5D	I	P2.6	Shift data input
USIC0_CH1.DX5E	I	P1.4	Shift data input
USIC0_CH1.DX5F	I	P1.5	Shift data input
USIC0_CH1.DX5G	I	USIC0.SR0	Shift data input

**Universal Serial Interface Channel (USIC)**

**Table 15-23 USIC Module 0 Channel 1 Interconnects (cont'd)**

<b>Input/Output</b>	<b>I/O</b>	<b>Connected To</b>	<b>Description</b>
USIC0_CH1.HWIN3	I	USIC0_CH1.DOUT0	HW controlled shift data input
<b>Data Outputs</b>			
USIC0_CH1.DOUT0	O	P0.6 P0.7 P1.2 P1.3 P2.10 P2.11 USIC0_CH1.DX3G USIC0_CH1.HWIN3	Shift data output
USIC0_CH1.DOUT1	O	not connected	Shift data output
USIC0_CH1.DOUT2	O	not connected	Shift data output
USIC0_CH1.DOUT3	O	not connected	Shift data output
<b>Clock Outputs</b>			
USIC0_CH1.MCLKOUT	O	P0.6 P0.15	Master clock output
USIC0_CH1.SCLKOUT	O	P0.8 P1.3 P1.4 P2.1 P2.11 USIC0_CH1.DX4G	Shift clock output
<b>Control Outputs</b>			
USIC0_CH1.SELO0	O	P0.0 P0.9 P1.1	Shift control output
USIC0_CH1.SELO1	O	P0.10 P1.4	Shift control output
USIC0_CH1.SELO2	O	P0.11 P1.5	Shift control output
USIC0_CH1.SELO3	O	not connected	Shift control output
USIC0_CH1.SELO4	O	not connected	Shift control output
USIC0_CH1.SELO5	O	not connected	Shift control output
USIC0_CH1.SELO6	O	not connected	Shift control output

**Universal Serial Interface Channel (USIC)**

**Table 15-23 USIC Module 0 Channel 1 Interconnects (cont'd)**

<b>Input/Output</b>	<b>I/O</b>	<b>Connected To</b>	<b>Description</b>
USIC0_CH1.SELO7	O	not connected	Shift control output
<b>System Related Outputs</b>			
USIC0_CH1.DX0INS	O	USIC0_CH1.DX1F	Selected DX0 input signal
USIC0_CH1.DX1INS	O	not connected	Selected DX1 input signal
USIC0_CH1.DX2INS	O	CCU40.IN1L	Selected DX2 input signal
USIC0_CH1.DX3INS	O	USIC0_CH1.DX0G	Selected DX3 input signal
USIC0_CH1.DX4INS	O	USIC0_CH1.DX1G	Selected DX4 input signal
USIC0_CH1.DX5INS	O	USIC0_CH1.DX2G USIC0_CH1.DX3F USIC0_CH1.DX4F	Selected DX5 input signal

**Table 15-24 USIC Module 0 Module Interconnects**

<b>Input/Output</b>	<b>I/O</b>	<b>Connected To</b>	<b>Description</b>
USIC0_SR0	O	NVIC USIC0_CH1.DX5G	interrupt output lines (service requests SRx)
USIC0_SR[5:1]	O	NVIC	interrupt output lines (service requests SRx)

# **Analog Peripherals**



## 16 Versatile Analog-to-Digital Converter (VADC)

The XMC1200 provides a series of analog input channels connected to a cluster of Analog/Digital Converters using the Successive Approximation Register (SAR) principle to convert analog input values (voltages) to discrete digital values.

The XMC1200 is based on Sample&Hold converters, where a cluster contains 2 Sample&Hold units which share a common converter.

The number of analog input channels and ADCs depends on the chosen product type (please refer to **“Product-Specific Configuration” on Page 16-151**).

**Table 16-1 Abbreviations used in ADC chapter**

<b>Abbreviation</b>	<b>Meaning</b>
ADC	Analog to Digital Converter
ADC Kernel	also known as ADC Group
DNL	Differential Non-Linearity (error)
INL	Integral Non-Linearity (error)
LSB <sub>n</sub>	Least Significant Bit: finest granularity of the analog value in digital format, represented by one least significant bit of the conversion result with n bits resolution (measurement range divided in 2 <sup>n</sup> equally distributed steps)
S&H	Sample and Hold
SCU	System Control Unit of the device
SHS	Sample and Hold Sequencer
TUE	Total Unadjusted Error

### 16.1 Overview

Each converter of the ADC cluster can operate independent of the others, controlled by a dedicated set of registers and triggered by a dedicated group request source. The results of each channel can be stored in a dedicated channel-specific result register or in a group-specific result register.

A background request source can access all analog input channels that are not assigned to any group request source. These conversions are executed with low priority. The background request source can, therefore, be regarded as an additional background converter.

The Versatile Analog to Digital Converter module (VADC) of the XMC1200 comprises a set of converter blocks that can be operated either independently or via a common

---

**Versatile Analog-to-Digital Converter (VADC)**

request source that emulates a background converter. Each converter block is equipped with a dedicated input multiplexer and dedicated request sources, which together build separate groups.

This basic structure supports application-oriented programming and operating while still providing general access to all resources. The almost identical converter groups allow a flexible assignment of functions to channels.

**Feature List**

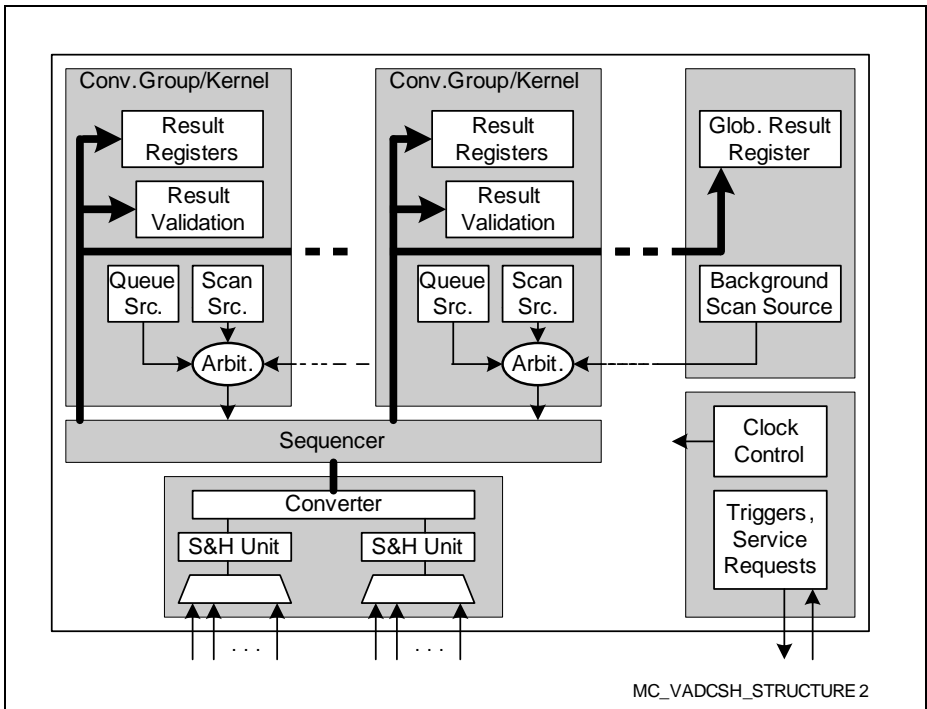
The following features describe the functionality of the ADC cluster:

- Input voltage range from 0 V up to analog supply voltage
- Standard ( $V_{AREF}$ ) reference voltage source and alternate Ground (CH0) selectable for each channel to support ratiometric measurements and different signal scales
- Two independent sample and hold stages with 8 analog input channels each
- Two active sigma delta hold blocks provided supporting oversampling
- External analog multiplexer control, including adjusted sample time and scan support
- Conversion speed and sample time adjustable to adapt to sensors and reference
- Conversion time below 1  $\mu$ s (depending on result width and sample time)
- Flexible source selection and arbitration
  - Programmable arbitrary conversion sequence (single or repeated)
  - Configurable auto scan conversion (single or repeated) in each group
  - Configurable auto scan conversion (single or repeated) in the background (all channels)
  - Conversions triggered by software, timer events, or external events
  - Cancel-inject-restart mode for reduced conversion delay on priority channels
- Powerful result handling
  - Selectable result width of 8/10/12 bits
  - Fast Compare Mode
  - Independent result registers
  - Configurable limit checking against programmable border values
  - Data rate reduction through adding a selectable number of conversion results
  - FIR/IIR filter with selectable coefficients
- Flexible service request generation based on selectable events (2 group-specific, 2 shared interrupts)
- Built-in safety feature: Broken wire detection with programmable default levels
- Support of debug suspend and power saving modes

*Note: Additional functions are available from the out of range comparator (see description in the SCU).*

**Table 16-2 VADC Applications**

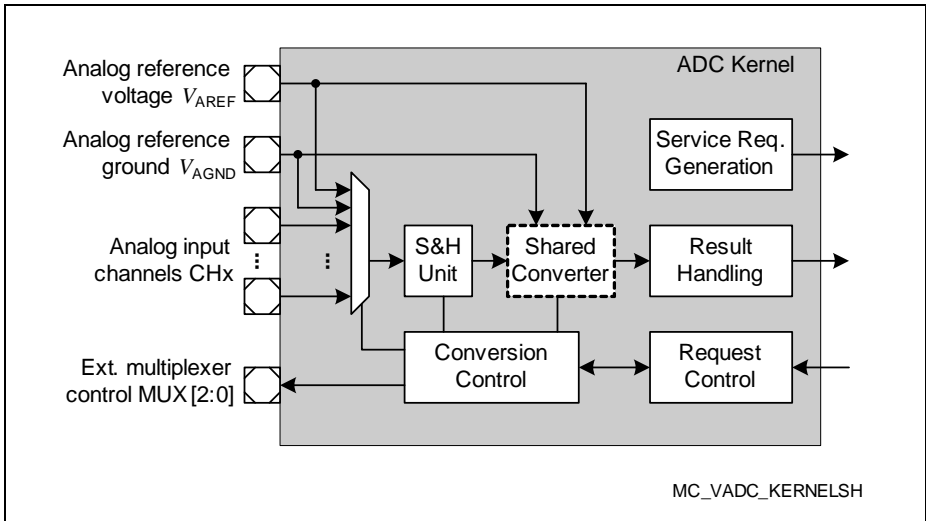
Use Case VADC	Application
Automatic scheduling of complex conversion sequences, including prioritization of time-critical conversions	Motor control, Power conversion
Effective result handling for bursts of high-speed conversions	Highly dynamic input signals
Synchronous sampling of up to 4 input signals	Multi-phase current measurement



**Figure 16-1 ADC Structure Overview**

## 16.2 Introduction and Basic Structure

The Versatile Analog to Digital Converter module (VADC) of the XMC1200 comprises a set of converter blocks that can be operated either independently or via a common request source that emulates a background converter. Each converter block is equipped with a dedicated input multiplexer and dedicated request sources, which together build separate groups.



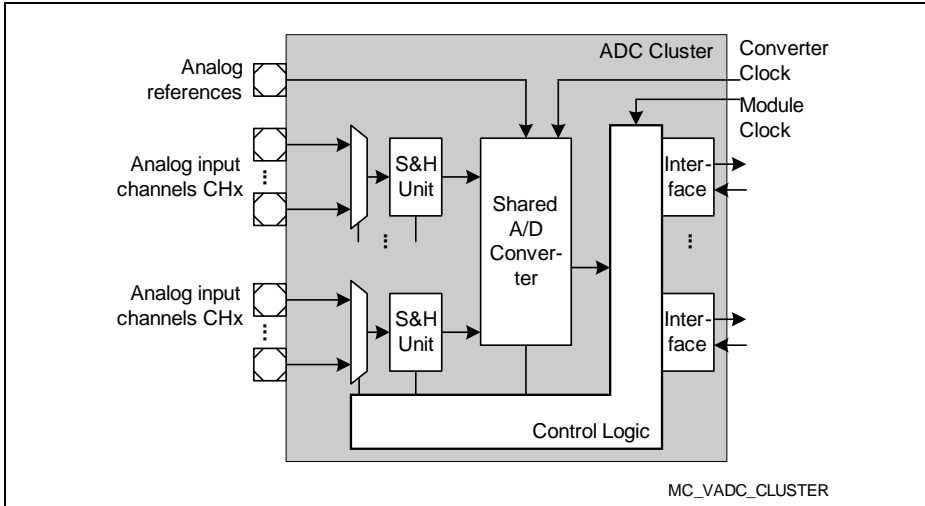
**Figure 16-2 ADC Kernel Block Diagram**

This basic structure supports application-oriented programming and operating while still providing general access to all resources. The almost identical converter groups allow a flexible assignment of functions to channels.

A set of functional units can be configured according to the requirements of a given application. These units build a path from the input signals to the digital results.

Each kernel provides a dedicated Sample&Hold unit connected to the input multiplexer. Several kernels build a cluster and share a common high-speed converter, whose performance can be assigned to the connected kernels.

**Versatile Analog-to-Digital Converter (VADC)**



**Figure 16-3 ADC Cluster Structure**

The basic module clock  $f_{ADC}$  is connected to the system clock signal  $f_{MCLK}$ .  
The converter clock  $f_{CONV}$  is connected to a 32-MHz clock signal.

**Conversion Modes and Request Sources**

Analog/Digital conversions can be requested by several request sources (2 group request sources and the background request source) and can be executed in several conversion modes. The request sources can be enabled concurrently with configurable priorities.

- **Fixed Channel Conversion (single or continuous)**  
A specific channel source requests conversions of one selectable channel (once or repeatedly)
- **Auto Scan Conversion (single or continuous)**  
A channel scan source (request source 1 or 2) requests auto scan conversions of a configurable linear sequence of all available channels (once or repeatedly)
- **Channel Sequence Conversion (single or continuous)**  
A queued source (request source 0) requests a sequence of conversions of up to 8 arbitrarily selectable channels (once or repeatedly)

The conversion modes can be used concurrently by the available request sources, i.e. conversions in different modes can be enabled at the same time. Each source can be enabled separately and can be triggered by external events, such as edges of PWM or timer signals, or pin transitions.

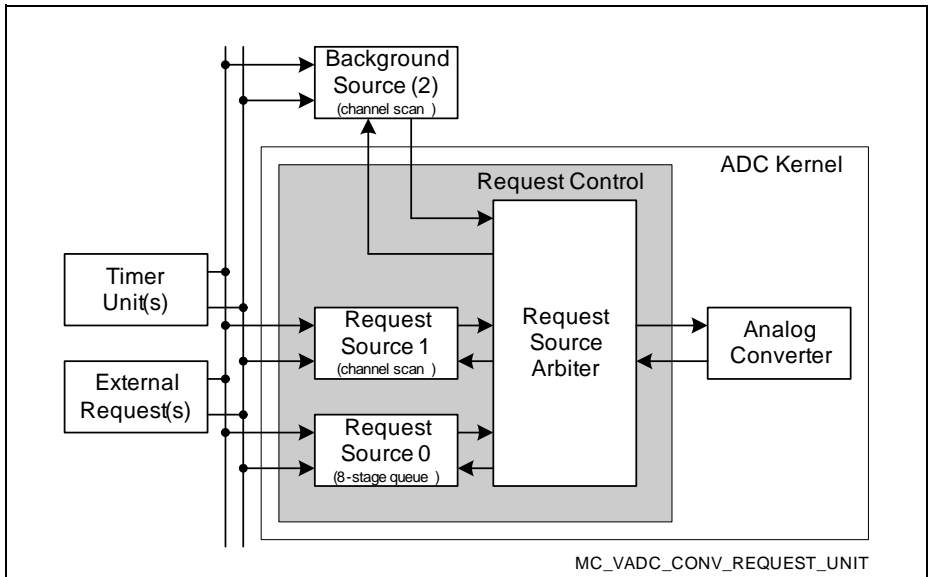
**Versatile Analog-to-Digital Converter (VADC)**

**Request Source Control**

Because all request sources can be enabled at the same time, an arbiter resolves concurrent conversion requests from different sources. Each source can be triggered by external signals, by on-chip signals, or by software.

Requests with higher priority can either cancel a running lower-priority conversion (cancel-inject-repeat mode) or be converted immediately after the currently running conversion (wait-for-start mode). If the target result register has not been read, a conversion can be deferred (wait-for-read mode).

Certain channels can also be synchronized with other ADC kernels, so 2 signals can be converted in parallel.



**Figure 16-4 Conversion Request Unit**

**Input Channel Selection**

The analog input multiplexer selects one of the available analog inputs (CH0 - CHx<sup>1)</sup> to be converted. Three sources can select a linear sequence, an arbitrary sequence, or a specific channel. The priorities of these sources can be configured.

1) The availability of dedicated input channels depends on the package of the used product type. A summary can be found in [Section 16.17.2](#).

---

**Versatile Analog-to-Digital Converter (VADC)**

Additional external analog multiplexers can be controlled automatically, if more separate input channels are required than are built in.

*Note: Not all analog input channels are necessarily available in all packages, due to pin limitations. Please refer to the implementation description in [Section 16.17](#).*

**Conversion Control**

Conversion parameters, such as sample phase duration, reference voltage, or result resolution can be configured for 4 input classes (2 group-specific classes, 2 global classes). Each channel can be individually assigned to one of these input classes.

The input channels can, thus, be adjusted to the type of sensor (or other analog sources) connected to the ADC.

This unit also controls the built-in multiplexer and external analog multiplexers, if selected.

**Analog/Digital Converter**

The selected input channel is converted to a digital value by first sampling the voltage on the selected input and then generating the selected number of result bits.

The sample&hold units of a cluster share a common high-speed converter. This converter sequentially generates result values for all sample&hold units. Calibration cycles are executed automatically.

For broken wire detection (see [Section 16.13.1](#)), the converter network can be precharged to a selected voltage before sampling the selected input channel.

**Result Handling**

The conversion results of each analog input channel can be directed to one of 16 group-specific result registers and one global result register to be stored there. A result register can be used by a group of channels or by a single channel.

The wait-for-read mode avoids data loss due to result overwrite by blocking a conversion until the previous result has been read.

Data reduction (e.g. for digital anti-aliasing filtering) can automatically add up to 4 conversion results before issuing a service request.

Alternatively, an FIR or IIR filter can be enabled that preprocesses the conversion results before sending them to the result register.

Also, result registers can be concatenated to build FIFO structures that store a number of conversion results without overwriting previous data. This increases the allowed CPU latency for retrieving conversion data from the ADC.

---

## Versatile Analog-to-Digital Converter (VADC)

### Interrupt Service Request Generation

Several ADC events can issue service requests to the CPU:

- **Source events** indicate the completion of a conversion sequence in the corresponding request source. This event can be used to trigger the setup of a new sequence.
- **Channel events** indicate the completion of a conversion for a certain channel. This can be combined with limit checking, as a result the interrupts are generated only if the result is within a defined range of values.
- **Result events** indicate the availability of new result data in the corresponding result register. If data reduction mode is active, events are generated only after a complete accumulation sequence.

Each event can be assigned to one of eight service request nodes. This allows grouping the requests according to the requirements of the application.

### Safety Features

Safety-aware applications are supported with mechanisms that help to ensure the integrity of a signal path.

**Broken-wire-detection (BWD)** preloads the converter network with a selectable level before sampling the input channel. The result will then reflect the preload value if the input signal is no more connected. If buffer capacitors are used, a certain number of conversions may be required to reach the failure indication level.

**Multiplexer Diagnostics (MD)** connects a weak pull-up or pull-down device to an input channel. A subsequent conversion can then confirm the expected modified signal level. This allows to check the proper operation of the multiplexer.

The pull devices are controlled via the standard port control registers.



### 16.3 Electrical Models

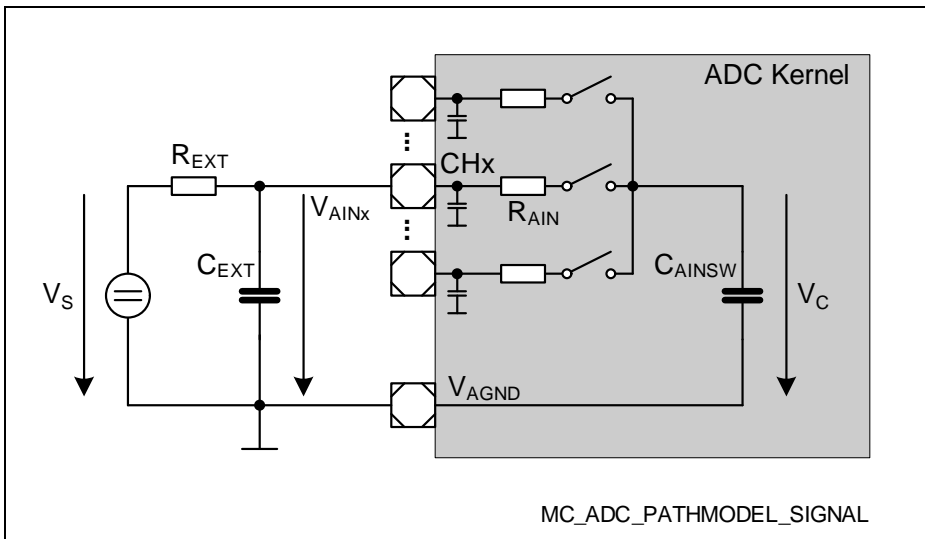
Each conversion of an analog input voltage to a digital value consists of two consecutive phases:

- During the sample phase, the input voltage is sampled and stored.  
The input signal path is a simplified model for this.
- During the conversion phase the stored voltage is converted to a digital result.

#### Input Signal Path

The ADC of the XMC1200 uses a switched capacitor field represented by  $C_{AINSW}$  (small parasitic capacitances are present at each input pin). During the sample phase, the capacitor field  $C_{AINSW}$  is connected to the selected analog input CHx via the input multiplexer (modeled by ideal switches and series resistors  $R_{AIN}$ ).

The switch to CHx is closed during the sample phase and connects the capacitor field to the input voltage  $V_{AINx}$ .



**Figure 16-5 Signal Path Model**

A simplified model for the analog input signal path is given in **Figure 16-5**. An analog voltage source (value  $V_S$ ) with an internal impedance of  $R_{EXT}$  delivers the analog input that should be converted.

During the sample phase the corresponding switch is closed and the capacitor field  $C_{AINSW}$  is charged. Due to the low-pass behavior of the resulting RC combination, the voltage  $V_C$  to be actually converted does not immediately follow  $V_S$ . The value  $R_{EXT}$  of

**Versatile Analog-to-Digital Converter (VADC)**

the analog voltage source and the desired precision of the conversion strongly define the required length of the sample phase.

To reduce the influence of  $R_{EXT}$  and to filter input noise, it is recommended to introduce a fast external blocking capacitor  $C_{EXT}$  at the analog input pin of the ADC. Like this, mainly  $C_{EXT}$  delivers the charge during the sample phase. This structure allows a significantly shorter sample phase than without a blocking capacitor, because the low-pass time constant defining the sample time is mainly given by the values of  $R_{AIN}$  and  $C_{AINSW}$ .

The resulting low-pass filter of  $R_{EXT}$  (usually a parameter of the signal source) and  $C_{EXT}$  should be dimensioned according to the application's requirements:

- For quickly changing dynamic signals, a smaller capacitor allows  $V_{AINx}$  to follow  $V_S$  between two sample phases of the same analog input channel.
- For high-precision conversions, an external blocking capacitor  $C_{EXT}$  in the range of at least  $2^n \times C_{AINSW}$  keeps the voltage change of  $V_{AINx}$  during the sample phase below  $1 \text{ LSB}_n$ . This voltage change is due to the charge redistribution between  $C_{EXT}$  and  $C_{AINSW}$ .

Leakage current through the analog input structure of the ADC can generate a voltage drop over  $R_{EXT}$ , introducing an error. The ADC input leakage current increases at high temperature and if the input voltage level is close to the analog supply ground  $V_{SS}$  or to the analog power supply  $V_{DDPA}$ . The input leakage current of an ADC channel can be reduced by avoiding input voltages close to the supplies.

An overload condition (input voltage exceeds the supply range) at adjacent analog inputs injects an additional leakage current (defined by a coupling factor).

The capacitor  $C_{AINSW}$  is automatically discharged at the beginning of a sample phase.

---

**Versatile Analog-to-Digital Converter (VADC)****Transfer Characteristics and Error Definitions**

The transfer characteristic of the ADC describes the association of analog input voltages to the  $2^n$  discrete digital result values ( $n$  bits resolution). Each digital result value (in the range of 0 to  $2^n-1$ ) represents an input voltage range defined by the reference voltage range divided by  $2^n$ . This range (called quantization step or code width) represents the granularity (called  $LSB_n$ ) of the ADC. The discrete character of the digital result generates a system-inherent quantization uncertainty of  $\pm 0.5 LSB_n$  for each conversion result.

The ideal transfer curve has the first digital transition (between 0 and 1) when the analog input reaches  $0.5 LSB_n$ . The quantization steps are equally distributed over the input voltage range.

Analog input voltages below or above the reference voltage limits lead to a saturation of the digital result at 0 or  $2^n-1$ .

The real transfer curve can exhibit certain deviations from the ideal transfer curve:

- The **offset error** is the deviation of the real transfer line from the ideal transfer line at the lowest code. This refers to best-fit lines through all possible codes, for both cases.
- The **gain error** is the deviation of the slope of the real transfer line from the slope of the ideal transfer line. This refers to best-fit lines through all possible codes, for both cases.
- The **differential non-linearity error (DNL)** is the deviation of the real code width (variation of the analog input voltage between two adjacent digital conversion results) from the ideal code width.
- The **integral non-linearity error (INL)** is the deviation of the real transfer curve from an adjusted ideal transfer curve (same offset and gain error as the real curve, but equal code widths).
- The **total unadjusted error (TUE)** describes the maximum deviation between a real conversion result and the ideal transfer characteristics over a given measurement range. Since some of these errors noted above can compensate each other, the TUE value generally is much less than the sum of the individual errors.

The TUE also covers production process variations and internal noise effects (if switching noise is generated by the system, this generally leads to an increased TUE value).

**Versatile Analog-to-Digital Converter (VADC)**

**16.4 Configuration of General Functions**

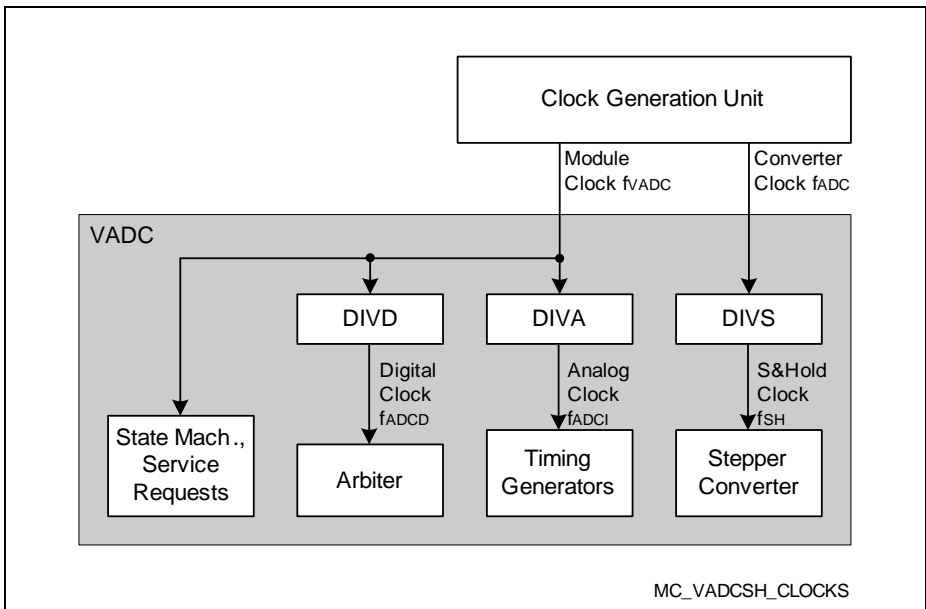
While many parameters can be selected individually for each channel, source, or group, some adjustments are valid for the whole ADC cluster:

- Clock control
- Kernel synchronization
- External multiplexer control

**16.4.1 General Clocking Scheme and Control**

The A/D Converters of the XMC1200 are supplied with a global clock signal from the system  $f_{ADC}$ . This clock signal controls all functions of all logic blocks and determines the overall timing. The global configuration register defines common clock bases for all converters of the cluster. This ensures deterministic behavior of converters that shall operate in parallel.

The converter clock  $f_{CONV}$  determines the performance of the converters themselves.



**Figure 16-6 Clock Signal Summary**

**16.4.2 Register Access Control**

Several protection schemes are provided to prevent unintended write access to control bitfields of the VADC.

---

### **Versatile Analog-to-Digital Converter (VADC)**

- A specific register access control scheme provides a versatile protection scheme against unintended corruption of register contents. Registers **ACCPROTO** and **ACCPROT1** allow the restriction of write accesses for several groups of registers. The registers to be protected can be selected by the user. **Table 16-10** lists the registers that belong to each register group. Registers ACCPROT0/1 themselves are protected by the bit protection scheme described SCU chapter.
- Groups of bitfields within a register may also be protected by an associated write control bit. This write control bit (xxWC) must be written with 1 along with the write access to the intended bitfield(s).

#### **16.4.3 Priority Channel and Result Register Assignment**

Each channel and result register of a group can be assigned to this group's request sources and is then regarded as a priority channel or result register.

##### **Priority Channel Assignment**

An assigned priority channel can only be converted by its own group's request sources. An unassigned channel can also be converted by the background request source.

##### **Priority Result Register Assignment**

An assigned result register can only be written by its own group's request sources. A not assigned result register can also be written by the background request source.

**Versatile Analog-to-Digital Converter (VADC)**

**16.5 Analog Module Activation and Control**

The analog converter of the ADC is the functional block that generates the digital result values from the selected input voltage. It draws a permanent current during its operation and can be deactivated between conversions to reduce the consumed overall energy.

*Note: After reset the analog converters are off. They must be enabled before triggering any action involving a converter.*

The accuracy of the conversions is improved by calibrating the analog converter to compensate process, temperature, and voltage variations.

**16.5.1 Analog Converter Control**

The operating mode is determined by bitfield **GxARBCFG (x = 0 - 1).ANONS**:

- **ANONS = 11<sub>B</sub>: Normal Operation**  
The converter is active, conversions are started immediately.  
Requires no wakeup time.
- **ANONS = 10<sub>B</sub>: Reserved**
- **ANONS = 01<sub>B</sub>: Slow Standby mode**  
The converter enters a power save mode while no activity is required. It automatically returns to normal operation if a conversion is requested. Slow standby mode enables the lowest overall power consumption for the ADC supply.  
Requires the wakeup time (see below).
- **ANONS = 00<sub>B</sub>: Converter switched Off** (default after reset)  
The converter is switched off if all groups of the corresponding cluster are off. Furthermore, digital logic blocks are set to their initial state. If the arbiter is currently running, it completes the actual arbitration round and then stops.  
Before starting a conversion, select the active mode for ANONS.  
Requires the extended wakeup time (see below).

Bit ANOFF in register SHSCFG forces the analog part into power-down mode, without changing the configuration of the associated groups. While ANOFF = 0, the analog part is controlled automatically as selected by bitfields ANONS in the digital part. Since several groups (with separate ANONS bitfields) are serviced by the same cluster, the analog part is controlled by the following scheme:

**Table 16-3 Analog Part Power-Down Control Options**

<b>ANON Settings<sup>1)</sup></b>	<b>Power-Down Mode</b>
All ANON signals are 00 <sub>B</sub>	Analog part off

**Versatile Analog-to-Digital Converter (VADC)**

**Table 16-3 Analog Part Power-Down Control Options (cont'd)**

<b>ANON Settings<sup>1)</sup></b>	<b>Power-Down Mode</b>
ANON signals are 00 <sub>B</sub> or 01 <sub>B</sub>	Analog part automatically switched off while no sample-phase and no conversion is active
One or more ANON signals are 11 <sub>B</sub>	Analog part always active

1) Taken into account while bit ANOFF = 0.

*Note: Since switching off the analog part requires a wake-up phase, the optimum configuration depends on the actual application.*

**Wakeup Time from Analog Powerdown**

When the converter is activated, it needs a certain wakeup time to settle before a conversion can be properly executed. This wakeup time can be established by waiting the required period before starting a conversion, or by adding it to the intended sample time.

The wakeup time is approximately 15 μs. Exact numbers can be found in the respective Data Sheets.

*Note: The wakeup time is also required after initially enabling the converter.*

**16.5.2 Calibration**

Calibration automatically compensates deviations caused by process, temperature, and voltage variations. This ensures precise results throughout the operation time.

Several different calibration cycles are executed for offset and gain calibration. To minimize the extra time consumed by calibration, offset and gain calibration cycles are executed alternating.

An initial start-up calibration is required once after a reset for all converters. All converters must be enabled (ANONS = 11<sub>B</sub>). The start-up calibration is initiated globally by setting bit SUCAL in register GLOBCFG. By setting bit SUCAL in register CALCTR the start-up calibration can be initiated for the corresponding cluster converter. Conversions may be started after the initial calibration sequence. This is indicated by bit CALS = 1<sub>B</sub> AND bit CAL = 0<sub>B</sub>.

The start-up calibration phase takes 1 920 cycles (1 920 × 31.25 ns = 60 μs).

After that, calibration cycles will compensate the effects of drifting parameters. The calibration cycles can be executed before or after (user configuration) a conversion sequence or can be disabled.

A calibration timer automatically triggers calibration cycles during idle phases of the ADC. This ensures the specified performance even after an idle phase.

---

## **Versatile Analog-to-Digital Converter (VADC)**

*Note: The ADC error depends on the temperature. Therefore, the calibration must be repeated periodically.*

### **Maximum Calibration Interval**

While no conversions are requested, the stepper remains in its idle state. In order not to lose accuracy, a counter counts the time since the last executed calibration. This timer is loaded after each calibration with the start value from bitfield CALCTR.CALMAX and counts  $512 \times (\text{CALMAX} + 1)$  clocks. If it expires it generates a calibration request which starts the stepper to execute a calibration cycle.

### **16.5.3 Sigma-Delta-Loop Function**

Each standard analog-digital conversion incurs a quantization error due to the limited number of steps i.e. discrete result values. By activating the sigma-delta-loop function this residual quantization error can be forwarded to the next conversion. The residual charge is stored and added to the next sampled charge. Averaging a series of conversion results (with the loop enabled) can, therefore, reduce the induced quantization error.

*Note: The data accumulation function of the VADCDIG already supports this averaging.*

The loop control bitfields are available in pairs in register **SHS0\_LOOP**.



## 16.6 Conversion Request Generation

The conversion request unit of a group autonomously handles the generation of conversion requests. Three request sources (2 group-specific sources and the background source) can generate requests for the conversion of an analog channel. The arbiter resolves concurrent requests and selects the channel to be converted next.

Upon a trigger event, the request source requests the conversion of a certain analog input channel or a sequence of channels.

- **Software triggers**  
directly activate the respective request source.
- **External triggers**  
synchronize the request source activation with external events, such as a trigger pulse from a timer generating a PWM signal or from a port pin.

Application software selects the trigger type and source, the channel(s) to be converted, and the request source priority. A request source can also be activated directly by software without requiring an external trigger.

The arbiter regularly scans the request sources for pending conversion requests and selects the conversion request with the highest priority. This conversion request is then forwarded to the converter to start the sampling and conversion of the requested channel.

Each request source can operate in single-shot or in continuous mode:

- **In single-shot mode,**  
the programmed conversion (sequence) is requested once after being triggered. A subsequent conversion (sequence) must be triggered again.
- **In continuous mode,**  
the programmed conversion (sequence) is automatically requested repeatedly after being triggered once.

For each request source, external triggers are generated from one of 16 selectable trigger inputs (REQTRx[P:A]) and from one of 16 selectable gating inputs (REQGTx[P:A]). The available trigger signals for the XMC1200 are listed in [Section 16.17.3](#).

*Note: [Figure 16-4 “Conversion Request Unit” on Page 16-6](#) summarizes the request sources.*

---

**Versatile Analog-to-Digital Converter (VADC)**

Two types of request sources are available:

- **A queued source** can issue conversion requests for an arbitrary sequence of input channels. The channel numbers for this sequence can be freely programmed<sup>1)</sup>. This supports application-specific conversion sequences that cannot be covered by a channel scan source. Also, multiple conversions of the same channel within a sequence are supported.

A queued source converts a series of input channels continuously or on a regular time base. For example, if programmed with medium priority, some input channels can be converted upon a specified event (e.g. synchronized to a PWM). Conversions of lower priority sources are suspended in the meantime.

Request source 0 is a group-specific 8-stage queued source.

- **A channel scan source** can issue conversion requests for a coherent sequence of input channels. This sequence begins with the highest enabled channel number and continues towards lower channel numbers. All available channels<sup>1)</sup> can be enabled for the scan sequence. Each channel is converted once per sequence.

A scan source converts a series of input channels continuously or on a regular time base. For example, if programmed with low priority, some input channels can be scanned in a background task to update information that is not time-critical.

- Request source 1 is a group-specific channel scan source.
- Request source 2 is a global channel scan source (background source).

The background source can request conversions of all channels of all groups.

---

1) The availability of dedicated input channels depends on the package of the used product type. A summary can be found in [Section 16.17.2](#).

The background source can only request non-priority channels, i.e. channels that are not selected in registers GxCHASS. Priority channels are reserved for the group-specific request sources 0 and 1.

### 16.6.1 Queued Request Source Handling

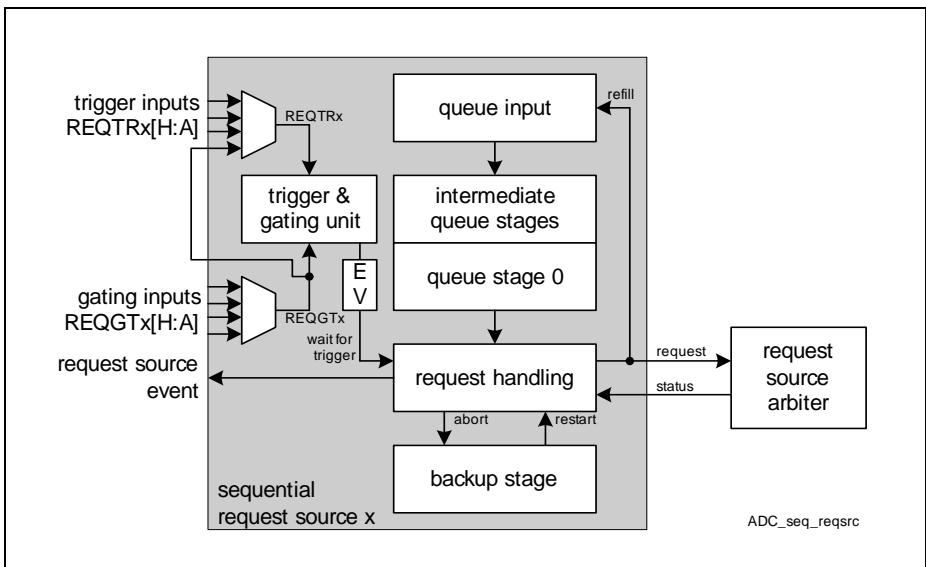
A queued request source supports short conversion sequences (up to 8) of arbitrary channels of the same group (contrary to a scan request source with a fixed conversion order for the enabled channels). The programmed sequence is stored in a queue buffer (based on a FIFO mechanism). The requested channel numbers are entered via the queue input register **GxQINR0 (x = 0 - 1)**, while queue stage 0 defines the channel to be converted next.

A conversion request is only issued to the request source arbiter if a valid entry is stored in queue stage 0.

If the arbiter aborts a conversion triggered by a queued request source due to higher priority requests, the corresponding conversion parameters are automatically saved in the backup stage. This ensures that an aborted conversion is not lost but takes part in the next arbitration round (before stage 0).

The trigger and gating unit generates trigger events from the selected external (outside the ADC) trigger and gating signals. For example, a timer unit can issue a request signal to synchronize conversions to PWM events.

Trigger events start a queued sequence and can be generated either via software or via the selected hardware triggers. The occurrence of a trigger event is indicated by bit **QSRx.EV**. This flag is cleared when the corresponding conversion is started or by writing to bit **QMRx.CEV**.



**Figure 16-7 Queued Request Source**

## Versatile Analog-to-Digital Converter (VADC)

A sequence is defined by entering conversion requests into the queue input register (**GxQINR0 (x = 0 - 1)**). Each entry selects the channel to be converted and can enable an external trigger, generation of an interrupt, and an automatic refill (i.e. copy this entry to the top of the queue after conversion). The entries are stored in the queue buffer stages.

The content of stage 0 (**GxQ0R0 (x = 0 - 1)**) selects the channel to be converted next. When the requested conversion is started, the contents of this queue stage is invalidated and copied to the backup stage. Then the next queue entry can be handled (if available).

*Note: The contents of the queue stages cannot be modified directly, but only by writing to the queue input or by flushing the queue.*

*The current status of the queue is shown in register **GxQSR0 (x = 0 - 1)**.*

*If all queue entries have automatic refill selected, the defined conversion sequence can be repeated without re-programming.*

### Properties of the Queued Request Source

Queued request source 0 provides 8 buffer stages and can handle sequences of up to 8 input channel entries. It supports short application-specific conversion sequences, especially for timing-critical sequences containing also multiple conversions of the same channel.

### Queued Source Operation

**Configure the queued request source** by executing the following actions:

- Define the sequence by writing the entries to the queue input **GxQINR0 (x = 0 - 1)**. Initialize the complete sequence before enabling the request source, because with enabled refill feature, software writes to QINRx are not allowed.
- If hardware trigger or gating is desired, select the appropriate trigger and gating inputs and the proper transitions by programming **GxQCTRL0 (x = 0 - 1)**. Enable the trigger and select the gating mode by programming bitfield ENGT in register **GxQMR0 (x = 0 - 1)**.<sup>1)</sup>
- Enable the corresponding arbitration slot (0) to accept conversion requests from the queued source (see register **GxARBPR (x = 0 - 1)**).

**Start a queued sequence** by generating a trigger event:

- If a hardware trigger is selected and enabled, generate the configured transition at the selected input signal, e.g. from a timer or an input pin.
- Generate a software trigger event by setting **GxQMR0.TREV = 1**.

1) If PDOUT signals from the ERU are used, initialize the ERU accordingly before enabling the gate inputs to avoid un expected signal transitions.

## Versatile Analog-to-Digital Converter (VADC)

- Write a new entry to the queue input of an empty queue. This leads to a (new) valid queue entry that is forwarded to queue stage 0 and starts a conversion request (if enabled by GxQMR0.ENG1 and without waiting for an external trigger).

*Note: If the refill mechanism is activated, a processed entry is automatically reloaded into the queue. This permanently repeats the respective sequence (autoscan).*

*In this case, do not write to the queue input while the queued source is running.*

*Write operations to a completely filled queue are ignored.*

**Stop or abort an ongoing queued sequence** by executing one of the following actions:

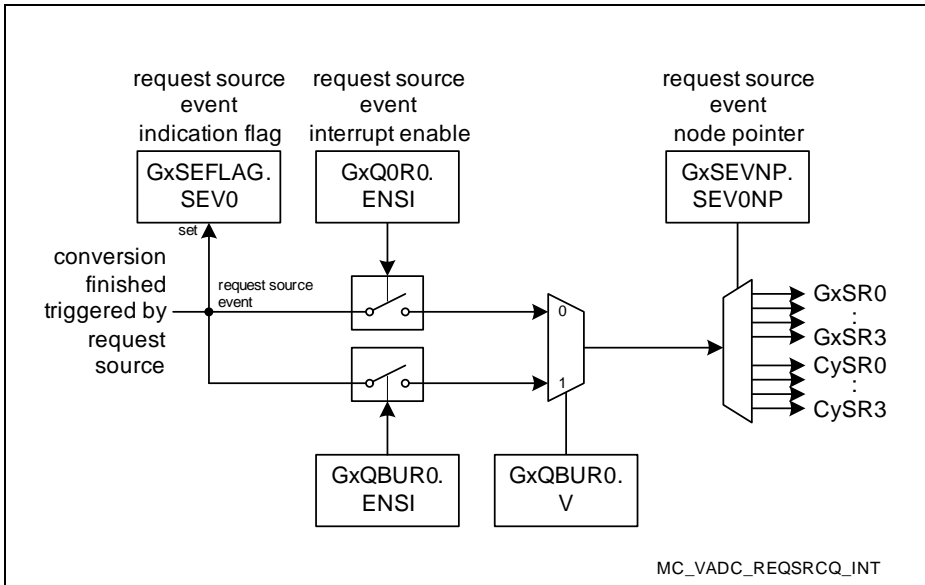
- If external gating is enabled, switch the gating signal to the defined inactive level. This does not modify the queue entries, but only prevents issuing conversion requests to the arbiter.
- Disable the corresponding arbitration slot (0) in the arbiter. This does not modify the queue entries, but only prevents the arbiter from accepting requests from the request handling block.
- Disable the queued source by clearing bitfield ENG1 = 00<sub>B</sub>.
  - Invalidate the next pending queue entry by setting bit GxQMR0.CLRV = 1. If the backup stage contains a valid entry, this one is invalidated, otherwise stage 0 is invalidated.
  - Remove all entries from the queue by setting bit GxQMR0.FLUSH = 1.

### Queue Request Source Events and Service Requests

A request source event of a queued source occurs when a conversion is finished. A source event service request can be generated based on a request source event according to the structure shown in [Figure 16-8](#). If a request source event is detected, it sets the corresponding indication flag in register **GxSEFLAG (x = 0 - 1)**. These flags can also be set by writing a 1 to the corresponding bit position, whereas writing 0 has no effect. The indication flags can be cleared by SW by writing a 1 to the corresponding bit position in register **GxSEFCLR (x = 0 - 1)**.

The interrupt enable bit is taken from stage 0 for a normal sequential conversion, or from the backup stage for a repeated conversion after an abort.

The service request output line SR<sub>x</sub> that is selected by the request source event interrupt node pointer bitfields in register **GxSEVNP (x = 0 - 1)** becomes activated each time the related request source event is detected (and enabled by GxQ0R0.ENS1, or GxQBUR0.ENS1 respectively) or the related bit position in register **GxSEFLAG (x = 0 - 1)** is written with a 1 (this write action simulates a request source event).



**Figure 16-8 Interrupt Generation of a Queued Request Source**

### 16.6.2 Channel Scan Request Source Handling

The VADC provides two types of channel scan sources:

- **Source 1: Group scan source**  
This scan source can request all channels of the corresponding group.
- **Source 2: Background scan source**  
This scan source can request all channels of all groups.  
Priority channels selected in registers **GxCHASS (x = 0 - 1)** cannot take part in background conversion sequences.

Both sources operate in the same way and provide the same register interface. The background source provides more request/pending bits because it can request all channels of all groups.

Each analog input channel can be included in or excluded from the scan sequence by setting or clearing the corresponding channel select bit in register **GxASSEL (x = 0 - 1)** or **BRSELx (x = 0 - 1)**. The programmed register value remains unchanged by an ongoing scan sequence. The scan sequence starts with the highest enabled channel number and continues towards lower channel numbers.

Upon a load event, the request pattern is transferred to the pending bits in register **GxASPND (x = 0 - 1)** or **BRSPNDx (x = 0 - 1)**. The pending conversion requests indicate

**Versatile Analog-to-Digital Converter (VADC)**

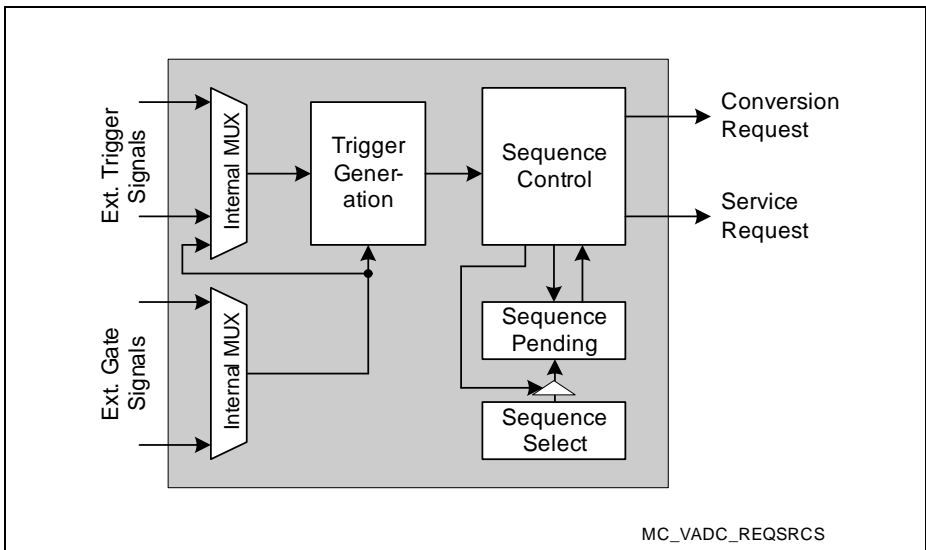
which input channels are to be converted in an ongoing scan sequence. Each conversion start that was triggered by the scan request source, automatically clears the corresponding pending bit. If the last conversion triggered by the scan source is finished and all pending bits are cleared, the current scan sequence is considered finished and a request source event is generated.

A conversion request is only issued to the request source arbiter if at least one pending bit is set.

If the arbiter aborts a conversion triggered by the scan request source due to higher priority requests, the corresponding pending bit is automatically set. This ensures that an aborted conversion is not lost but takes part in the next arbitration round.

The trigger and gating unit generates load events from the selected external (outside the ADC) trigger and gating signals. For example, a timer unit can issue a request signal to synchronize conversions to PWM events.

Load events start a scan sequence and can be generated either via software or via the selected hardware triggers. The request source event can also generate an automatic load event, so the programmed sequence is automatically repeated.



**Figure 16-9 Scan Request Source**

## Scan Source Operation

**Configure the scan request source** by executing the following actions:

- Select the input channels for the sequence by programming **GxASSEL (x = 0 - 1)** or **BRSELx (x = 0 - 1)**
- If hardware trigger or gating is desired, select the appropriate trigger and gating inputs and the proper signal transitions by programming **GxASCTRL (x = 0 - 1)** or **BRCTRL**. Enable the trigger and select the gating mode by programming **GxASMR (x = 0 - 1)** or **BRSMR**.<sup>1)</sup>
- Define the load event operation (handling of pending bits, autoscan mode) by programming **GxASMR (x = 0 - 1)** or **BRSMR**.  
A load event with bit LDM = 0 copies the content of **GxASSEL (x = 0 - 1)** or **BRSELx (x = 0 - 1)** to **GxASPND (x = 0 - 1)** or **BRSPNDx (x = 0 - 1)** (overwrite mode). This starts a new scan sequence and aborts any pending conversions from a previous scan sequence.  
A load event with bit LDM = 1 OR-combines the content of **GxASSEL (x = 0 - 1)** or **BRSELx (x = 0 - 1)** to **GxASPND (x = 0 - 1)** or **BRSPNDx (x = 0 - 1)** (combine mode). This starts a scan sequence that includes pending conversions from a previous scan sequence.
- Enable the corresponding arbitration slot (1) to accept conversion requests from the channel scan source (see register **GxARBPR (x = 0 - 1)**).

**Start a channel scan sequence** by generating a load event:

- If a hardware trigger is selected and enabled, generate the configured transition at the selected input signal, e.g. from a timer or an input pin.
- Generate a software load event by setting LDEV = 1 (**GxASMR (x = 0 - 1)** or **BRSMR**).
- Generate a load event by writing the scan pattern directly to the pending bits in **GxASPND (x = 0 - 1)** or **BRSPNDx (x = 0 - 1)**. The pattern is copied to **GxASSEL (x = 0 - 1)** or **BRSELx (x = 0 - 1)** and a load event is generated automatically.  
In this case, a scan sequence can be defined and started with a single data write action, e.g. under PEC control (provided that the pattern fits into one register).

*Note: If autoscan is enabled, a load event is generated automatically each time a request source event occurs when the scan sequence has finished. This permanently repeats the defined scan sequence (autoscan).*

**Stop or abort an ongoing scan sequence** by executing one of the following actions:

- If external gating is enabled, switch the gating signal to the defined inactive level. This does not modify the conversion pending bits, but only prevents issuing conversion requests to the arbiter.

<sup>1)</sup> If PDOUT signals from the ERU are used, initialize the ERU accordingly before enabling the gate inputs to avoid un expected signal transitions.



---

### **Versatile Analog-to-Digital Converter (VADC)**

- Disable the corresponding arbitration slot (1 or 2) in the arbiter. This does not modify the contents of the conversion pending bits, but only prevents the arbiter from accepting requests from the request handling block.
- Disable the channel scan source by clearing bitfield  $ENGT = 00_{\text{B}}$ . Clear the pending request bits by setting bit  $CLRPND = 1$  (**GxASMR (x = 0 - 1)** or **BRSMR**).

#### **Scan Request Source Events and Interrupt Service Requests**

A request source event of a scan source occurs if the last conversion of a scan sequence is finished (all pending bits = 0). A request source event interrupt can be generated based on a request source event. If a request source event is detected, it sets the corresponding indication flag in register **GxSEFLAG (x = 0 - 1)**. These flags can also be set by writing a 1 to the corresponding bit position, whereas writing 0 has no effect.

The service request output  $SR_x$  that is selected by the request source event interrupt node pointer bitfields in register **GxSEVNP (x = 0 - 1)** becomes activated each time the related request source event is detected (and enabled by ENSI) or the related bit position in register **GxSEFLAG (x = 0 - 1)** is written with a 1 (this write action simulates a request source event).

The indication flags can be cleared by SW by writing a 1 to the corresponding bit position in register **GxSEFCLR (x = 0 - 1)**.<sup>1)</sup>

---

1) Please refer to "[Service Request Generation](#)" on [Page 16-62](#).

## 16.7 Request Source Arbitration

The request source arbiter regularly polls the request sources of the respective group, one after the other, for pending conversion requests. Each request source is assigned to a certain time slot within an arbitration round, called arbitration slot. The duration of an arbitration slot is user-configurable via register **GLOBCFG**.

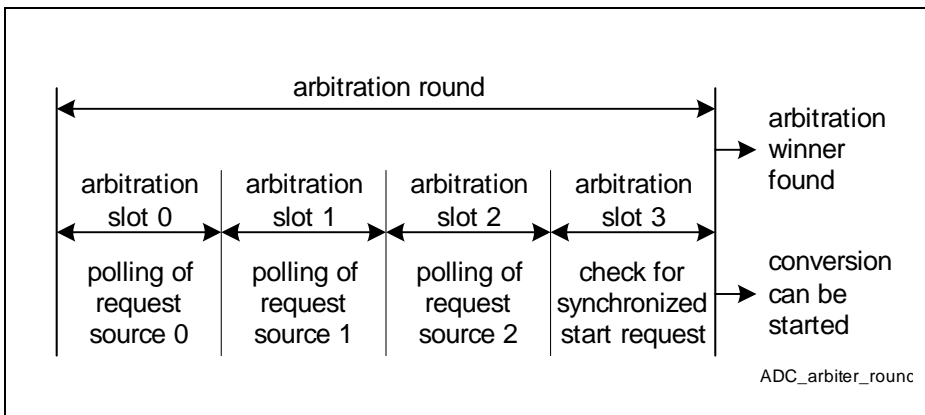
The priority of each request source is user-configurable via register **GxARBPR (x = 0 - 1)**, so the arbiter can select the next channel to be converted, in the case of concurrent requests from multiple sources, according to the application requirements.

An unused arbitration slot is considered empty and does not take part in the arbitration. After reset, all slots are disabled and must be enabled (register **GxARBPR (x = 0 - 1)**) to take part in the arbitration process.

**Figure 16-10** summarizes the arbitration sequence. An arbitration round consists of one arbitration slot for each available request source. The synchronization source is always evaluated in the last slot and has a higher priority than all other sources. At the end of each arbitration round, the arbiter has determined the highest priority conversion request.

If a conversion is started in an arbitration round, this arbitration round does not deliver an arbitration winner. In the XMC1200, the following request sources are available:

- Arbitration slot 0: **Group Queued source**, 8-stage sequences in arbitrary order
- Arbitration slot 1: **Group Scan source**, sequences in defined order within group
- Arbitration slot 2: **Background Scan source**, sequences in defined order, all groups
- Last arbitration slot: **Synchronization source**, synchronized conversion requests from another group (always handled with the highest priority in a synchronization slave group).



**Figure 16-10 Arbitration Round with 4 Arbitration Slots**

## 16.7.1 Arbiter Operation and Configuration

The timing of the arbiter (i.e. of an arbitration round) is determined by the number of arbitration slots within an arbitration round and by the duration of an arbitration slot.

An arbitration round consist of 4...20 arbitration slots (defined by bitfield **GxARBCFG (x = 0 - 1).ARBRND**). 4 slots are sufficient for the XMC1200, more can be programmed to obtain the same arbiter timing for different products.

The duration of an arbitration slot is configurable  $t_{\text{Slot}} = (\text{DIVD}+1) / f_{\text{ADC}}$ .

The duration of an arbitration round, therefore, is  $t_{\text{ARB}} = 4 \times t_{\text{Slot}}$ .

The period of the arbitration round introduces a timing granularity to detect an incoming conversion request signal and the earliest point to start the related conversion. This granularity can introduce a jitter of maximum one arbitration round. The jitter can be reduced by minimizing the period of an arbitration round.

To achieve a reproducible reaction time (constant delay without jitter) between the trigger event of a conversion request (e.g. by a timer unit or due to an external event) and the start of the related conversion, mainly the following two options exist. For both options, the converter has to be idle and other conversion requests must not be pending for at least one arbiter round before the trigger event occurs:

- If bit **GxARBCFG (x = 0 - 1).ARBM = 0**, the **arbiter runs permanently**. In this mode, synchronized conversions of more than one ADC kernel are possible.<sup>1)</sup>  
The trigger for a conversion request has to be generated synchronously to the arbiter timing. Incoming triggers should have exactly n-times the granularity of the arbiter (n = 1, 2, 3,...). In order to allow some flexibility, the duration of an arbitration slot can be programmed in cycles of  $f_{\text{ADC}}$ .
- If bit **GxARBCFG (x = 0 - 1).ARBM = 1**, the **arbiter stops after an arbitration round** when no conversion request have been found pending any more. The arbiter is started again if at least one enabled request source indicates a pending conversion request. The trigger for a conversion request does not need to be synchronous to the arbiter timing.

In this mode, parallel conversions are not possible for synchronization slave groups.

Each request source has a configurable priority, so the arbiter can resolve concurrent conversion requests from different sources. The request with the highest priority is selected for conversion. These priorities can be adapted to the requirements of a given application (see register **GxARBPR (x = 0 - 1)**).

The **Conversion Start Mode** determines the handling of the conversion request that has won the arbitration.

1) For more information, please refer to **"Synchronization of Conversions"** on [Page 16-54](#).

## 16.7.2 Conversion Start Mode

When the arbiter has selected the request to be converted next, the handling of this channel depends on the current activity of the converter:

- Converter is currently idle: the conversion of the arbitration winner is started immediately.
- Current conversion has same or higher priority: the current conversion is completed, the conversion of the arbitration winner is started after that.
- Current conversion has lower priority: the action is user-configurable:
  - **Wait-for-start mode:** the current conversion is completed, the conversion of the arbitration winner is started after that. This mode provides maximum throughput, but can produce a jitter for the higher priority conversion.

Example in [Figure 16-11](#):

Conversion A is requested (t1) and started (t2). Conversion B is then requested (t3), but started only after completion of conversion A (t4).

- **Cancel-inject-repeat mode:** the current conversion is aborted, the conversion of the arbitration winner is started after the abortion ( $3 f_{ADC}$  cycles).

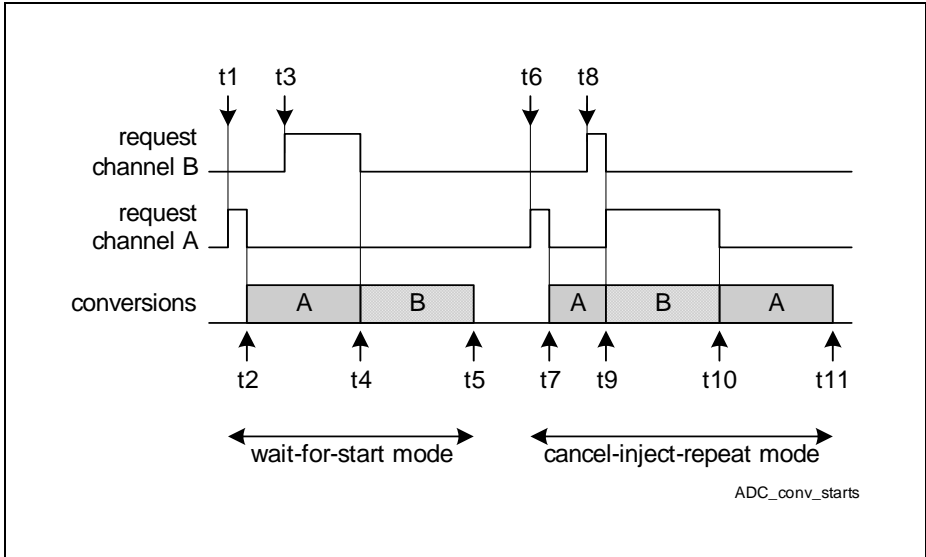
The aborted conversion request is restored in the corresponding request source and takes part again in the next arbitration round. This mode provides minimum jitter for the higher priority conversions, but reduces the overall throughput.

Example in [Figure 16-11](#):

Conversion A is requested (t6) and started (t7). Conversion B is then requested (t8) and started (t9), while conversion A is aborted but requested again. When conversion B is complete (t10), conversion A is restarted.

Exception: If both requests target the same result register with wait-for-read mode active (see [Section 16.11.3](#)), the current conversion cannot be aborted.

*Note: A cancelled conversion can be repeated automatically in each case, or it can be discarded if it was cancelled. This is selected for each source by bit RPTDIS in the corresponding source's mode register.*



**Figure 16-11 Conversion Start Modes**

The conversion start mode can be individually programmed for each request source by bits in register **GxARBPR (x = 0 - 1)** and is applied to all channels requested by the source. In this example, channel A is issued by a request source with a lower priority than the request source requesting the conversion of channel B.

## 16.8 Analog Input Channel Configuration

For each analog input channel a number of parameters can be configured that control the conversion of this channel. The channel control registers define the following parameters:

- **Channel Parameters:** The sample time for this channel and the data width of the result are defined via input classes. Each channel can select one of two classes of its own group or one of two global classes.
- **Reference selection:** an alternate reference ground can be selected
- **Result target:** The conversion result values are stored either in a group-specific result register or in the global result register. The group-specific result registers are selected channel-specific, selected by bitfield RESREG in register **G0CHCTry (y = 0 - 7)** etc.
- **Result position:** The result values can be stored left-aligned or right-aligned. The exact position depends also on the configured result width and on the data accumulation mode.

See also **Figure 16-18 “Result Storage Options” on Page 16-44.**

- **Compare with Standard Conversions (Limit Checking):** Channel events can be generated whenever a new result value becomes available. Channel event generation can be restricted to values that lie inside or outside a user-configurable band.

In Fast Compare Mode, channel events can be generated depending on the transitions of the (1-bit) result.

- **Broken Wire Detection:** This safety feature can detect a missing connection to an analog signal source (sensor).
- **Synchronization of Conversions:** Synchronized conversions are executed at the same time on several converters.

The **Alias Feature** redirects conversion requests defined at channels CH0 and/or CH1 to other analog input channels.

### 16.8.1 Channel Parameters

Each analog input channel is configured by its associated channel control register.

*Note: For the safety feature “Broken Wire Detection”, refer to **Section 16.13.1.***

The following features can be defined for each channel:

- The conversion class defines the result width and the sample time
- Generation of channel events and the result value band, if used
- Target of the result defining the target register and the position within the register

The group-specific input class registers define the sample time and data conversion mode for each channel of the respective group that selects them via bitfield ICLSEL in its channel control register GxCHCTry.

---

**Versatile Analog-to-Digital Converter (VADC)**

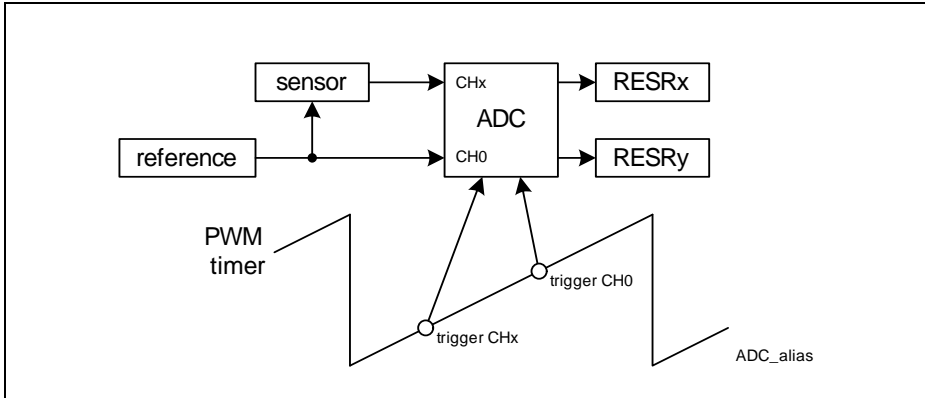
The global input class registers define the sample time and data conversion mode for each channel of any group that selects them via bitfield ICLSEL in its channel control register GxCHCTRY.

**16.8.2 Alias Feature**

The Alias Feature redirects conversion requests defined at channels CH0 and/or CH1 to other analog input channels (pins). This feature can be used to trigger conversions of the same input pin by independent events and to store the conversion results in different result registers.

- The same signal can be measured twice without the need to read out the conversion result to avoid data loss. This allows triggering both conversions quickly one after the other and being independent from CPU service request latency.
- The sensor signal is connected to only one analog input (instead of two analog inputs). This saves input pins in low-cost applications and only the leakage of one input has to be considered in the error calculation.
- Even if the analog input CH0 is used as alternative reference (see [Figure 16-12](#)), the internal trigger and data handling features for channel CH0 can be used.
- The channel settings for both conversions can be different (boundary values, service requests, etc.).

In typical low-cost AC-drive applications, only one common current sensor is used to determine the phase currents. Depending on the applied PWM pattern, the measured value has different meanings and the sample points have to be precisely located in the PWM period. [Figure 16-12](#) shows an example where the sensor signal is connected to one input channel (CHx) but two conversions are triggered for two different channels (CHx and CH0). With the alias feature, a conversion request for CH0 leads to a conversion of the analog input CHx instead of CH0, but taking into account the settings for CH0. Although the same analog input (CHx) has been measured, the conversion results can be stored and read out from the result registers RESx (conversion triggered for CHx) and RESy (conversion triggered for CH0). Additionally, different interrupts or limit boundaries can be selected, enabled or disabled.



**Figure 16-12 Alias Feature**

### 16.8.3 Conversion Modes

A conversion can be executed in several ways. The conversion mode is selected according to the requested resolution of the digital result and according to the acceptable conversion time ([Section 16.10](#)).

Use bitfield CMS/CME in register **GxICLASS0 (x = 0 - 1)** etc. to select a mode.

#### Standard Conversions

A standard conversion returns a result value with a predefined resolution. 8-bit, 10-bit, and 12-bit resolution can be selected.

These result values can be accumulated, filtered, or used for digital limit checking and determination of extrema.

*Note: The converters can operate with and without calibration steps.*

#### Fast Compare Mode

In Fast Compare Mode, the selected input voltage is directly compared with a digital value that is stored in the corresponding result register. This compare operation returns a binary result indicating if the compared input voltage is above or below the given reference value. This result is generated quickly and thus supports monitoring of boundary values.

Fast Compare Mode uses a 10-bit compare value stored left-aligned at bit position 11. Separate positive and negative delta values define an arbitrary hysteresis band.



## Selecting Compare Values

Values for digital or analog compare operations can be selected from several sources. The separate GxBOUND registers provide software-defined compare values.

In Fast Compare Mode, the result registers provide the compare value while the bitfields of local GxBOUND registers define positive and negative delta values.

### 16.8.4 Compare with Standard Conversions (Limit Checking)

The limit checking mechanism can automatically compare each digital conversion result to an upper and a lower boundary value. A channel event can then be generated when the result of a conversion/comparison is inside or outside a user-defined band (see bitfield CHEVMODE and [Figure 16-13](#)).

This feature supports automatic range monitoring and minimizes the CPU load by issuing service requests only under certain predefined conditions.

*Note: Channel events can also be generated for each result value (ignoring the band) or they can be suppressed completely.*

The boundary values to which results are compared can be selected from several sources (see register GxCHCTRY).

Bitfields BNDSELU and BNDSELL select the valid upper/lower boundary value either from the group-specific boundary register **GxBOUND (x = 0 - 1)** or from the global boundary register **GLOBBOUND**. The group boundary register can be selected for each channel of the respective group, the global boundary register can be selected by each available channel.

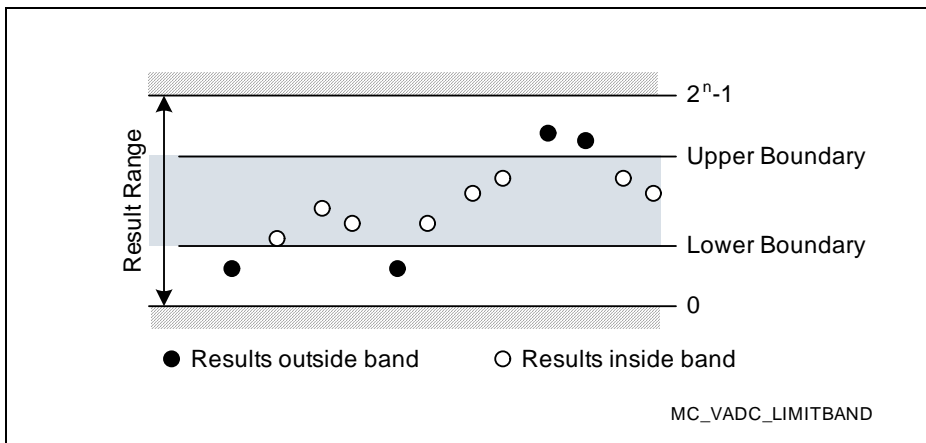


Figure 16-13 Result Monitoring through Limit Checking

## Versatile Analog-to-Digital Converter (VADC)

A result value is considered inside the defined band when both of the following conditions are true:

- the value is less than or equal to the selected upper boundary
- the value is greater than or equal to the selected lower boundary

The result range can also be divided into two areas:

To select the lower part as valid band, set the lower boundary to the minimum value ( $000_H$ ) and set the upper boundary to the highest intended value.

To select the upper part as valid band, set the upper boundary to the maximum value ( $FFF_H$ ) and set the lower boundary to the lowest intended value.

### Finding Extrema (Peak Detection)

The limit checking mechanism uses standard conversions and, therefore, always can provide the actual conversion result that was used for comparison. Combining this with a special FIFO mode, that only updates the corresponding FIFO stage if the result was above (or below) the current value of the stage, provides the usual conversion results and at the same time stores the highest (or lowest) result of a conversion sequence. For this operation the FIFO stage below the standard result must be selected as the compare value. Mode selection is done via bitfield FEN in register  $GxRCRy$ .

Before starting a peak detection sequence, write a reasonable start value to the result bitfield in the peak result register (e.g.  $0000_H$  to find the maximum and  $FFFF_H$  to find the minimum).

### 16.8.5 Utilizing Fast Compare Mode

In Fast Compare Mode, the input signal is directly compared to a value in the associated result register. This comparison just provides a binary result (above/below). If the exact result value is not required, this saves conversion time. A channel event can then be generated when the input signal becomes higher (or lower) than the compare value (see bitfield CHEVMODE and [Figure 16-14](#)).

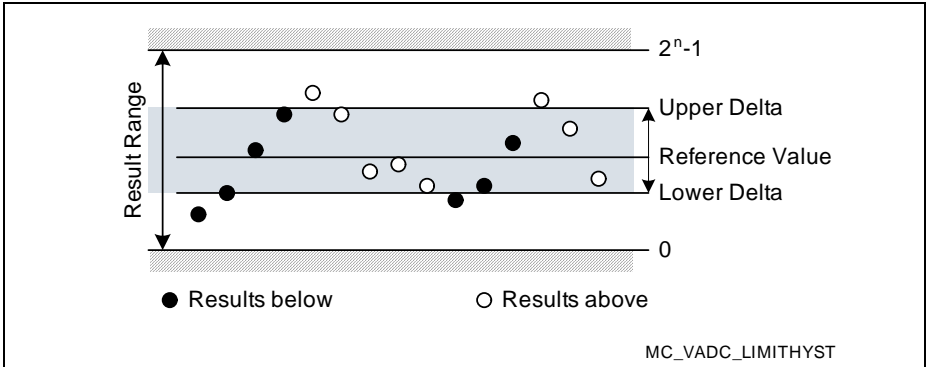
The compare value in Fast Compare Mode is taken from the result register. Bitfields BOUNDARY1 and BOUNDARY0 in register  $GxBOUND(x = 0 - 1)$  define delta limits in this case. These deltas are added to (or subtracted from) the original compare value and allow defining an arbitrary hysteresis band.

The actual used compare value depends on the Fast Compare Result FCR (see registers  $GORESy(y = 0 - 15)$ , etc.):

$GxRESy.FCR = 0$ : reference value + upper delta  
( $GxRESy.RESULT + GxBOUND.BOUNDARY0$ )

$GxRESy.FCR = 1$ : reference value - lower delta  
( $GxRESy.RESULT - GxBOUND.BOUNDARY1$ )

**Versatile Analog-to-Digital Converter (VADC)**



**Figure 16-14 Result Monitoring through Compare with Hysteresis**

### 16.8.6 Boundary Flag Control

Both limit checking mechanisms can be configured to automatically control the boundary flags. These boundary flags are also available as control signals for other modules. The flags can be set or cleared when the defined level is exceeded and the polarity of the output signal can be selected. A gate signal can be selected to enable the boundary flag operation while the gate is active.

Each boundary flag is available at group-specific output lines. Node pointers additionally route them to one of four boundary signals or one of the associated common service request lines, see register **GxBFLNP (x = 0 - 1)**.

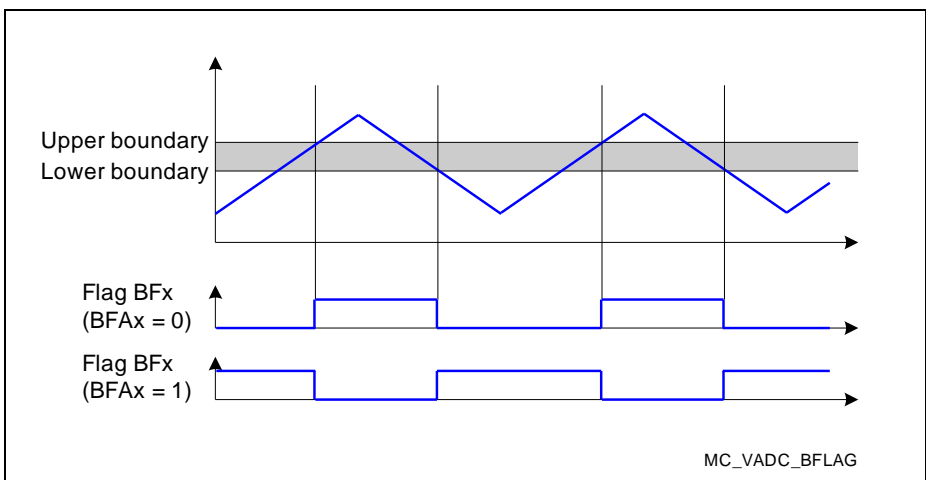
**For standard conversions**, a boundary flag will be set when the conversion result is above the defined band, and will be cleared when the conversion result is below the defined band.

The band between the two boundary values defines a hysteresis for setting/clearing the boundary flags.

Using this feature on three channels that monitor linear hall elements can produce signals to feed the three hall inputs of a position interface.

**In Fast Compare Mode**, a boundary flag reflects the result of the comparisons, i.e. it will be set/cleared when the compared signal level is above the compare value, and will be cleared/set when the signal level is below the compare value. The delta values define a hysteresis band around the compare value.

*Note: Clear register GxBOUND (i.e. the deltas) if a hysteresis is not wanted.*

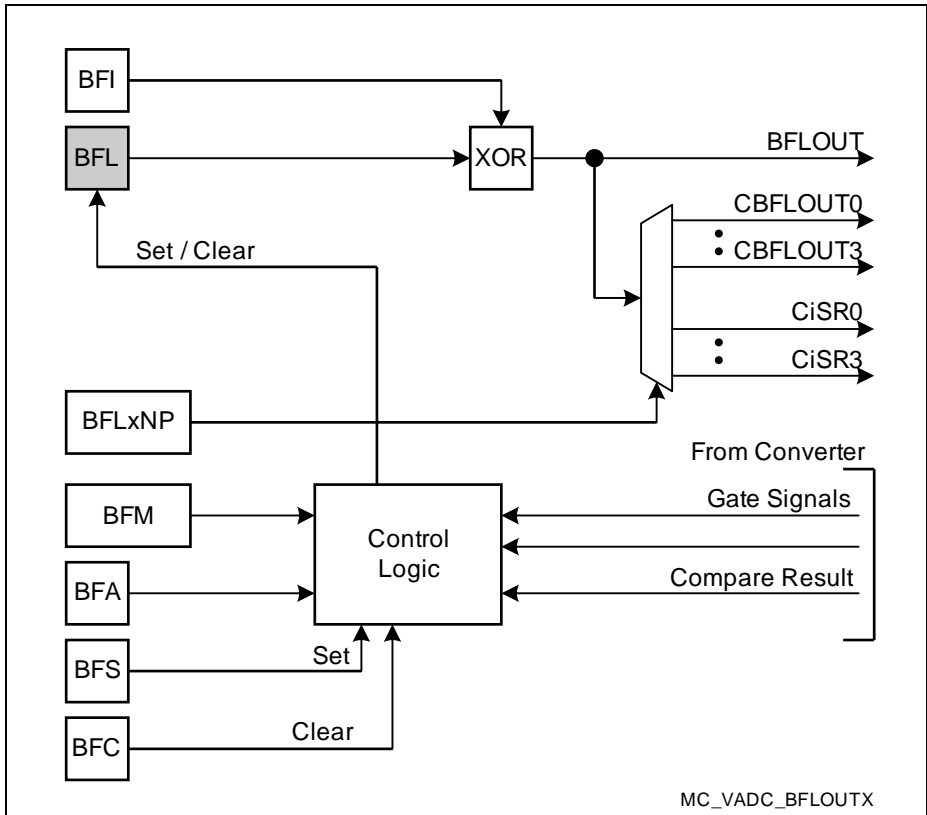


**Figure 16-15 Boundary Flag Switching**

**Versatile Analog-to-Digital Converter (VADC)**

Boundary flags can be switched by each compare operation, or the influence of compare operations can be restricted to the active phases of the corresponding request source gate signal (see **GxBFLC (x = 0 - 1)**).

*Note: If a boundary flag is used together with Fast Compare Mode, it is recommended not to direct results from other channels to the corresponding result register.*



**Figure 16-16 Boundary Flag Control**

A boundary flag BFLy is assigned to result register GxRESy and thus to an arbitrary channel.

### 16.9 Conversion Scheduling

The converter clusters of the VADC combine one high-speed converter with several sample&hold units which can operate in parallel.

---

**Versatile Analog-to-Digital Converter (VADC)**

The XMC1200 comprises 1 cluster with 2 S&H units each.

Since all S&H units use one converter, the actual conversion must be associated with certain S&H units. An 8-stage stepper continuously scans the conversion requests of the S&H units of a cluster and starts a conversion if one of them is found active.

Each of the 8 steps can be assigned to one of the available groups (via bitfield KSELx in register **SHSO\_STEPCFG**) and can be enabled to take part in the round-robin scheme. The default programming after reset establishes a linear round-robin scheme that enables and scans all interfaces one after the other. In this case, all interfaces are handled in the same way. The other steps are disabled.

By selecting certain groups multiple times within the stepper sequence the associated S&H units can be scanned more often. In particular in accelerated timing mode this leads to a higher conversion rate on these kernels. This additional functionality makes the enhanced performance of the SHADC available to the application.

Example:

Default: 0 - 1 (2) (3) (4) (5) (6) (7) [2 S&H units: steps 2-7 disabled]

Boost1: 0 - 1 - 1 (3) (4) (5) (6) (7) [steps 3-7 disabled]

*Note: The default configuration of the stepper provides an upward-compatible operation.*

Empty steps, i.e. steps where the associated S&H unit has no conversion request, are disregarded and the stepper proceeds with the next enabled step.

If all steps are empty the stepper enters its idle state until a conversion request or a calibration request (see **Section** ) is activated.

### General Timing Behavior

Conversion results are returned to the digital logic after the time interval defined by the parameters  $f_{\text{ADC}}$ , sample time, conversion width, etc. This compatible timing mode provides the same behavior as predecessor modules. This supports existing applications that are ported to the XMC1200.

To exploit the performance of the high-speed converter, an accelerated timing mode is enabled by setting bit AT in register TIMCFG. In this case, each result value is returned as soon as it is converted. Combined with boosting certain groups (see above) this can deliver a high conversion rate.

Also the sample time can be reduced (bitfield SST) to achieve higher conversion rates.

## 16.10 Conversion Timing

The total time required for a conversion comprises the time from the start of the sample phase<sup>1)</sup> until the availability of the result. Two modes can be selected:

- **Compatible timing mode:**  
The conversion timing is defined in the same way as known from predecessor modules. Existing applications find a smooth upgrade path.
- **Accelerated timing mode:**  
The conversion timing exploits the performance of the high-speed converter and the programmable stepper. Higher conversion rates can be achieved.

The frequency at which conversions are triggered also depends on several configurable factors:

- The selected conversion time, according to the input class definitions. For conversions using an external multiplexer, also the extended sample times count.
- Delays induced by cancelled conversions that must be repeated.
- Delays due to equidistant sampling of other channels.
- The configured arbitration cycle time.
- The frequency of external trigger signals, if enabled.

### 16.10.1 Compatible Timing Mode

The conversion timing depends on the following user-definable factors:

- The ADC conversion clock frequency, where  $f_{\text{ADCI}} = f_{\text{ADC}} / (\text{DIVA}+1)^2$
- The selected sample time, where  $t_{\text{S}} = (2 + \text{STC}) \times t_{\text{ADCI}}$   
(STC = additional sample time, see also [Table 16-11](#))
- The result width N (8/10/12 bits)
- The post-calibration time PC, if selected (PC = 2, otherwise 0)
- Synchronization steps done at module clock speed

The conversion time is the sum of sample time, conversion steps, and synchronization. It can be computed with the following formula:

$$t_{\text{CN}} = (2 + \text{STC} + \text{N} + \text{PC}) \times t_{\text{ADCI}} + 2 \times t_{\text{ADC}}$$

1) The time from the trigger event that requests the corresponding conversion until the start of the sample phase depends on the arbitration and can, therefore, only be determined when the system setup is known.

2)  $f_{\text{ADCI}}$  is a virtual frequency which is used to control the conversion timing in compatible timing mode.

### Timing Examples Compatible Mode

System assumptions:

$$f_{ADC} = 32 \text{ MHz i.e. } t_{ADC} = 31.25 \text{ ns, DIVA} = 1, f_{ADCI} = 16 \text{ MHz i.e. } t_{ADCI} = 62.5 \text{ ns}$$

According to the given formula the following minimum conversion times can be achieved:

12-bit calibrated conversion:

$$t_{CN12C} = (2 + 12 + 2) \times t_{ADCI} + 2 \times t_{ADC} = 16 \times 62.5 \text{ ns} + 2 \times 31.25 \text{ ns} = 1\ 062.5 \text{ ns}$$

10-bit uncalibrated conversion:

$$t_{CN10} = (2 + 10) \times t_{ADCI} + 2 \times t_{ADC} = 12 \times 62.5 \text{ ns} + 2 \times 31.25 \text{ ns} = 812.5 \text{ ns}$$

### 16.10.2 Accelerated Timing Mode

In accelerated timing mode, the standard timing configuration (described above) is not used, but each result becomes available as soon as it has been generated. The actual response time, therefore, depends on the position of the conversion within the cluster's conversion round

The conversion timing depends on the following user-definable factors:

- The converter clock frequency, where  $f_{SH} = f_{CONV} / (DIVS+1)$
- The selected sample time, where  $t_S = SST \times t_{ADC}$  (short sample time)
- The result width N (8/10/12 bits)
- The post-calibration time PC, if selected (PC = 2, otherwise 0)
- The position of the conversion within the stepper sequence
- Synchronization steps done at module clock speed

The conversion time is the sum of sample time, conversion steps, and synchronization. It can be computed with the following formula:

$$t_{CN} = (SST + 5^1) \times t_{ADC} + (N + 10) \times t_{SH} + (4 \times t_{SH})^2$$

### Timing Examples Accelerated Mode

System assumptions:

$$f_{CONV} = 32 \text{ MHz, DIVS} = 0, \text{ i.e. } t_{SH} = t_{CONV} = 31.25 \text{ ns,}$$

$$f_{ADC} = 32 \text{ MHz, i.e. } t_{ADC} = 31.25 \text{ ns,}$$

$$SST = 5, \text{ i.e. } t_S = 312.5 \text{ ns}$$

According to the given formula the following minimum conversion times can be achieved: (The numbers in parentheses apply for the 2nd conversion of a round)

12-bit conversion:

$$t_{CN12} = 10 \times t_{ADC} + 26 \times t_{SH} = 312.5 \text{ ns} + 26 \times 31.25 \text{ ns} = 1\ 125 \text{ ns} (1\ 812.5 \text{ ns})$$

1) These clock cycles are required to transport the converted result value to the digital result register. They only need to be counted when computing the total conversion performance of a cluster.

2) These clock cycles are required between the end of the sample phase and the beginning of the conversion. They can be excluded if this phase occurs during another conversion.



---

**Versatile Analog-to-Digital Converter (VADC)**

10-bit conversion:

$$t_{\text{CN10}} = 10 \times t_{\text{ADC}} + 24 \times t_{\text{SH}} = 312.5 \text{ ns} + 24 \times 31.25 \text{ ns} = 1\,062.5 \text{ ns} \text{ (1\,687.5 ns)}$$

The maximum calibration step<sup>1)</sup> takes another  $13 \times t_{\text{SH}}$ , so a complete conversion round including all 2 S&H units will take:

$$t_{\text{CR}} = 1\,812.5 \text{ ns} + 13 \times 31.25 \text{ ns} = 2\,219 \text{ ns} \text{ (12-bit conversion)}$$

---

1) Calibration steps are executed alternating, where gain calibration takes more time than offset calibration.

## 16.11 Conversion Result Handling

The A/D converters can preprocess the conversions result data to a certain extent before storing them for retrieval by the CPU. This supports the subsequent handling of result data by the application software.

Conversion result handling comprises the following functions:

- **Storage of Conversion Results** to user-configurable registers
- **Data Alignment** according to result width and endianness
- **Wait-for-Read Mode** to avoid loss of data
- **Result Event Generation**
- Data reduction or anti-aliasing filtering (see [Section 16.11.6](#))

### 16.11.1 Storage of Conversion Results

The conversion result values of a certain group can be stored in one of the 16 associated group result registers or in the common global result register (can be used, for example, for the channels of the background source (see [Selecting a Result Register](#))).

This structure provides different locations for the conversion results of different sets of channels. Depending on the application needs (data reduction, auto-scan, alias feature, etc.), the user can distribute the conversion results to minimize CPU load.

Each result register has an individual data valid flag (VF) associated with it. This flag indicates when “new” valid data has been stored in the corresponding result register and can be read out.

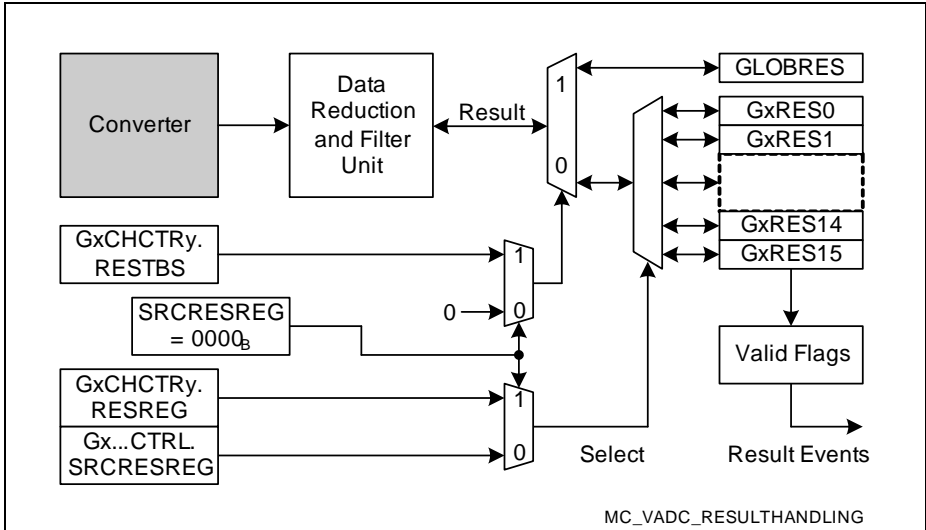
For standard conversions, result values are available in bitfield RESULT. Conversions in Fast Compare Mode use bitfield RESULT for the reference value, so the result of the operation is stored in bit FCR.

Result registers can be read via two different views. These views use different addresses but access the same register data:

- When a result register is read via the **application view**, the corresponding valid flag is automatically cleared when the result is read. This provides an easy handshake between result generation and retrieval. This also supports wait-for-read mode.
- When a result register is read via the **debug view**, the corresponding valid flag remains unchanged when the result is read. This supports debugging by delivering the result value without disturbing the handshake with the application.

The application can retrieve conversion results through several result registers:

- Group result register:  
Returns the result value and the channel number
- Global result register:  
Returns the result value and the channel number and the group number



**Figure 16-17 Conversion Result Storage**

### Selecting a Result Register

Conversion results are stored in result registers that can be assigned by the user according to the requirements of the application. The following bitfields direct the results to a register:

- SRCRESREG in register **GxQCTRL0 (x = 0 - 1)**, **GxASCTRL (x = 0 - 1)** or **BRCTRL**  
Selects the group-specific result register GxRES1 ... GxRES15 when source-specific result registers are used
- RESTBS in register **G0CHCTry (y = 0 - 7)** etc.  
Selects the global result register for results requested by the background source
- RESREG in register **G0CHCTry (y = 0 - 7)** etc.  
Selects the group-specific result register GxRES0 ... GxRES15 when channel-specific result registers are used

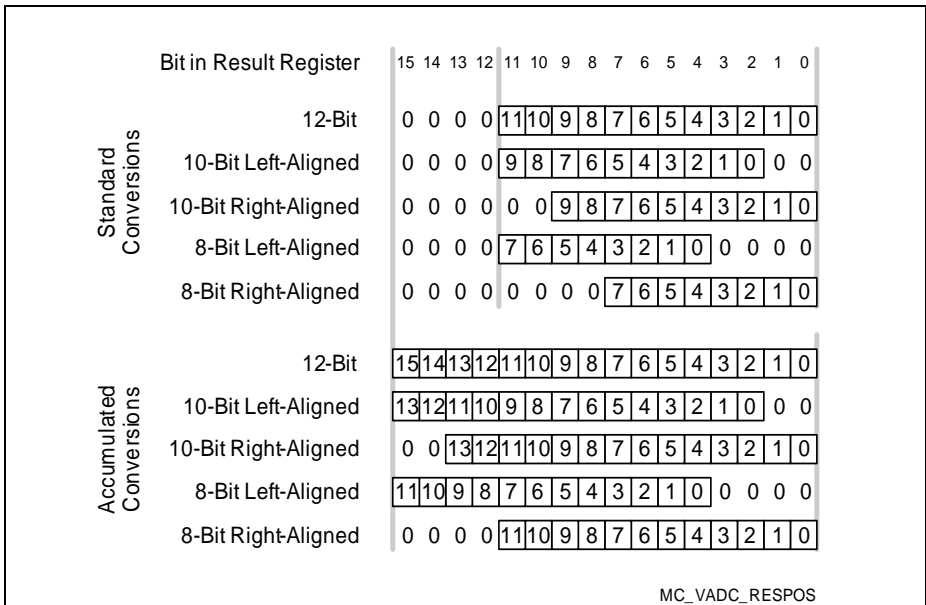
Using source-specific result registers allows separating results from the same channel that are requested by different request sources. Usually these request sources are used by different tasks and are triggered at different times.

### 16.11.2 Data Alignment

The position of a conversion result value within the selected result register depends on 3 configurations (summary in **Figure 16-18**):

- The selected result width (12/10/8 bits, selected by the conversion mode)
- The selected result position (Left/Right-aligned)
- The selected data accumulation mode (data reduction)

These options provide the conversion results in a way that minimizes data handling for the application software.



**Figure 16-18 Result Storage Options**

Bitfield RESULT can be written by software to provide the reference value for Fast Compare Mode. In this mode, bits 11-2 are evaluated, the other bits are ignored.

### 16.11.3 Wait-for-Read Mode

The wait-for-read mode prevents data loss due to overwriting a result register with a new conversion result before the CPU has read the previous data. For example, auto-scan conversion sequences or other sequences with “relaxed” timing requirements may use a common result register. However, the results come from different input channels, so an overwrite would destroy the result from the previous conversion<sup>1)</sup>.

Wait-for-read mode automatically suspends the start of a conversion for this channel from this source until the current result has been read. So a conversion or a conversion sequence can be requested by a hardware or software trigger, while each conversion is only started after the result of the previous one has been read. This automatically aligns the conversion sequence with the CPU capability to read the formerly converted result (latency).

If wait-for-read mode is enabled for a result register (bit GxRCRy.WFR = 1), a request source does not generate a conversion request while the targeted result register contains valid data (indicated by the valid flag VF = 1) or if a currently running conversion targets the same result register.

If two request sources target the same result register with wait-for-read mode selected, a higher priority source cannot interrupt a lower priority conversion request started before the higher priority source has requested its conversion. Cancel-inject-repeat mode does not work in this case. In particular, this must be regarded if one of the involved sources is the background source (which usually has lowest priority). If the higher priority request targets a different result register, the lower priority conversion can be cancelled and repeated afterwards.

*Note: Wait-for-read mode is ignored for synchronized conversions of synchronization slaves (see [Section 16.12](#)).*

---

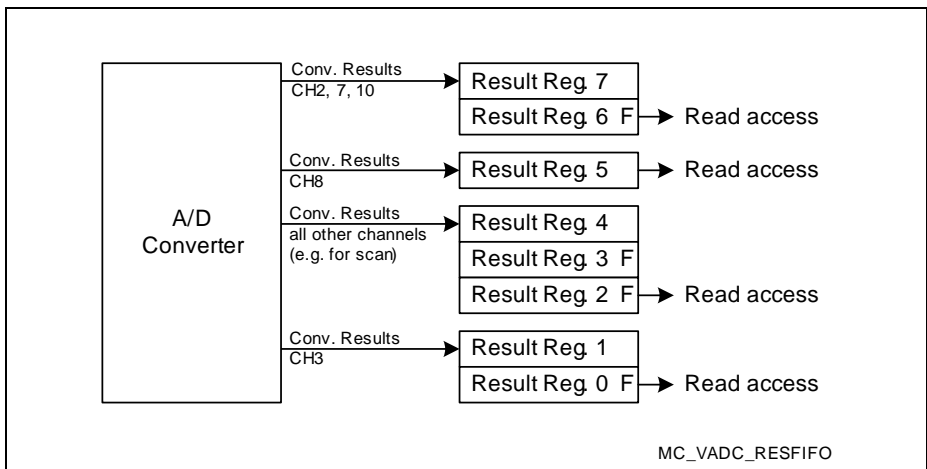
1) Repeated conversions of a single channel that use a separate result register will not destroy other results, but rather update their own previous result value. This way, always the actual signal data is available in the result register.

### 16.11.4 Result FIFO Buffer

Result registers can either be used as direct target for conversion results or they can be concatenated with other result registers of the same ADC group to form a result FIFO buffer (first-in-first-out buffer mechanism). A result FIFO stores several measurement results that can be read out later with a “relaxed” CPU response timing. It is possible to set up more than one FIFO buffer structure with the available result registers.

Result FIFO structures of two or more registers are built by concatenating result registers to their following “neighbor” result register (with next higher index, see [Figure 16-19](#)). This is enabled by setting bitfield GxRCRy.FEN = 01<sub>B</sub>.

Conversion results are stored to the register with the highest index of a FIFO structure. Software reads the values from the FIFO register with the lowest index.



**Figure 16-19 Result FIFO Buffers**

In the example shown the result registers have been configured in the following way:

- 2-stage buffer consisting of result registers 7-6
- dedicated result register 5
- 3-stage buffer consisting of result registers 4-3-2
- 2-stage buffer consisting of result registers 1-0

[Table 16-4](#) summarizes the required configuration of result registers if they are combined to build result FIFO buffers.

**Table 16-4 Properties of Result FIFO Registers**

Function	Input Stage	Intermed. Stage	Output Stage
Result target	YES	no	no
Application read	no	no	YES
Data reduction mode	YES	no	no
Wait-for-read mode	YES	no	no
Result event interrupt	no	no	YES
FIFO enable (FEN)	00 <sub>B</sub>	01 <sub>B</sub>	01 <sub>B</sub>
Registers in example	7, 4, 1	3	6, 2, 0

*Note: If enabled, a result interrupt is generated for each data word in the FIFO.*

### 16.11.5 Result Event Generation

A result event can be generated when a new value is stored to a result register. Result events can be restricted due to data accumulation and be generated only if the accumulation is complete.

Result events can also be suppressed completely.

### 16.11.6 Data Modification

The data resulting from conversions can be automatically modified before being used by an application. Several options can be selected (bitfield DMM in register **G0RCRy** (**y = 0 - 15**) etc.) which reduce the CPU load required to unload and/or process the conversion data.

- **Standard Data Reduction Mode (for GxRES0 ... GxRES15):**  
Accumulates 2, 3, or 4 result values within each result register before generating a result interrupt. This can remove some noise from the input signal.
- **Result Filtering Mode (FIR, for GxRES7, GxRES15):**  
Applies a 3rd order Finite Impulse Response Filter (FIR) with selectable coefficients to the conversion results for the selected result register.
- **Result Filtering Mode (IIR, for GxRES7, GxRES15):**  
Applies a 1st order Infinite Impulse Response Filter (IIR) with selectable coefficients to the conversion results for the selected result register.
- **Difference Mode (for GxRES1 ... GxRES15):**  
Subtracts the contents of result register GxRES0 from the conversion results for the selected result register. Bitfield DRCTR is not used in this mode.

**Versatile Analog-to-Digital Converter (VADC)**

**Table 16-5 Function of Bitfield DRCTR**

<b>DRCTR</b>	<b>Standard Data Reduction Mode (DMM = 00<sub>B</sub>)</b>	<b>DRCTR</b>	<b>Result Filtering Mode (DMM = 01<sub>B</sub>)<sup>1)</sup></b>
0000 <sub>B</sub>	Data Reduction disabled	0000 <sub>B</sub>	FIR filter: a=2, b=1, c=0
0001 <sub>B</sub>	Accumulate 2 result values	0001 <sub>B</sub>	FIR filter: a=1, b=2, c=0
0010 <sub>B</sub>	Accumulate 3 result values	0010 <sub>B</sub>	FIR filter: a=2, b=0, c=1
0011 <sub>B</sub>	Accumulate 4 result values	0011 <sub>B</sub>	FIR filter: a=1, b=1, c=1
0100 <sub>B</sub>	Reserved	0100 <sub>B</sub>	FIR filter: a=1, b=0, c=2
0101 <sub>B</sub>	Reserved	0101 <sub>B</sub>	FIR filter: a=3, b=1, c=0
0110 <sub>B</sub>	Reserved	0110 <sub>B</sub>	FIR filter: a=2, b=2, c=0
0111 <sub>B</sub>	Reserved	0111 <sub>B</sub>	FIR filter: a=1, b=3, c=0
1000 <sub>B</sub>	Reserved	1000 <sub>B</sub>	FIR filter: a=3, b=0, c=1
1001 <sub>B</sub>	Reserved	1001 <sub>B</sub>	FIR filter: a=2, b=1, c=1
1010 <sub>B</sub>	Reserved	1010 <sub>B</sub>	FIR filter: a=1, b=2, c=1
1011 <sub>B</sub>	Reserved	1011 <sub>B</sub>	FIR filter: a=2, b=0, c=2
1100 <sub>B</sub>	Reserved	1100 <sub>B</sub>	FIR filter: a=1, b=1, c=2
1101 <sub>B</sub>	Reserved	1101 <sub>B</sub>	FIR filter: a=1, b=0, c=3
1110 <sub>B</sub>	Reserved	1110 <sub>B</sub>	IIR filter: a=2, b=2
1111 <sub>B</sub>	Reserved	1111 <sub>B</sub>	IIR filter: a=3, b=4

1) The filter registers are cleared while bitfield DMM ≠ 01<sub>B</sub>.



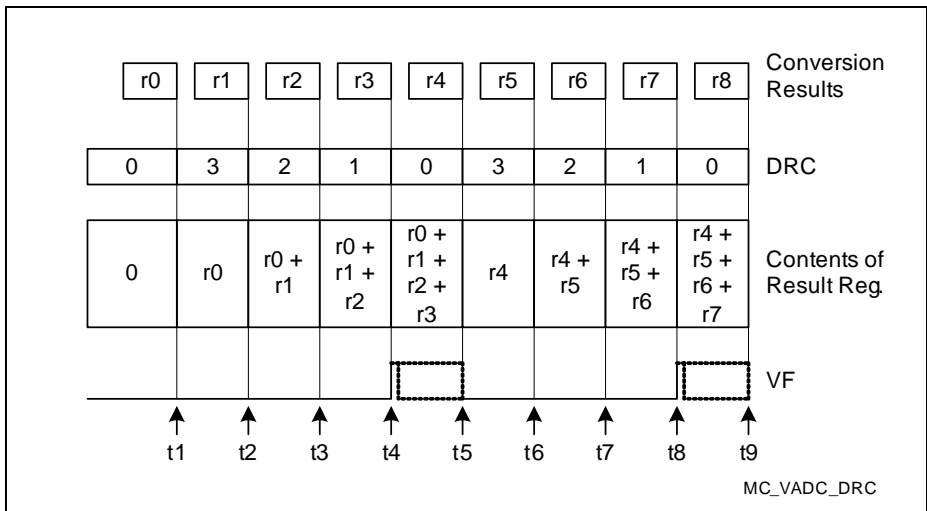
**Versatile Analog-to-Digital Converter (VADC)**

**Standard Data Reduction Mode**

The data reduction mode can be used as digital filter for anti-aliasing or decimation purposes. It accumulates a maximum of 4 conversion values to generate a final result.

Each result register can be individually enabled for data reduction, controlled by bitfield DRCTR in registers **GOCHCTry (y = 0 - 7)**. The data reduction counter DRC indicates the actual status of the accumulation.

*Note: Conversions for other result registers can be inserted between conversions to be accumulated.*



**Figure 16-20 Standard Data Reduction Filter**

This example shows a data reduction sequence of 4 accumulated conversion results. Eight conversion results (r0 ... r7) are accumulated and produce 2 final results.

When a conversion is complete and stores data to a result register that has data reduction mode enabled, the data handling is controlled by the data reduction counter DRC:

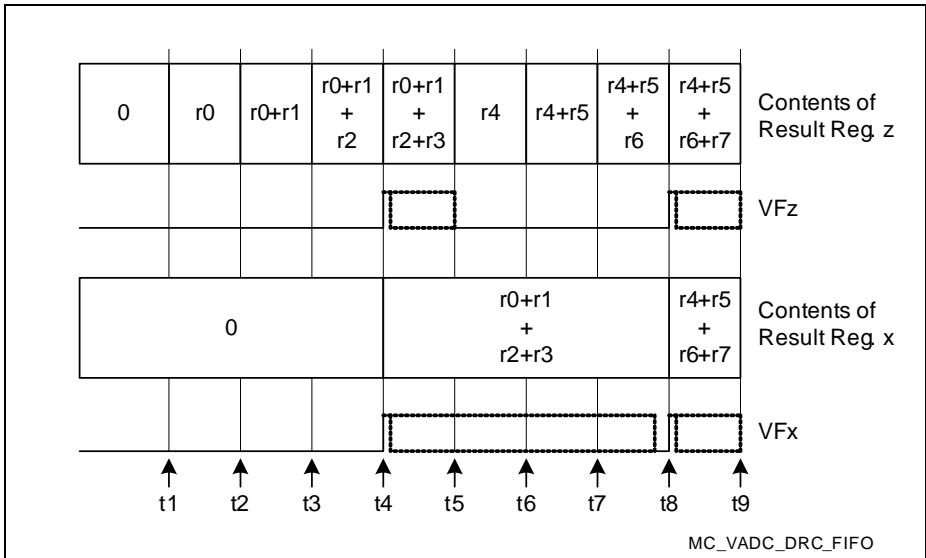
- If DRC = 0 (t1, t5, t9 in the example), the conversion result is stored to the register. DRC is loaded with the contents of bitfield DRCTR (i.e. the accumulation begins).
- If DRC > 0 (t2, t3, t4 and t6, t7, t8 in the example), the conversion result is added to the value in the result register. DRC is decremented by 1.
- If DRC becomes 0, either decremented from 1 (t4 and t8 in the example) or loaded from DRCTR, the valid bit for the respective result register is set and a result register event occurs.

**Versatile Analog-to-Digital Converter (VADC)**

The final result must be read before the next data reduction sequence starts (before t5 or t9 in the example). This automatically clears the valid flag.

*Note: Software can clear the data reduction counter DRC by clearing the corresponding valid Flag (via **GxVFR (x = 0 - 1)**).*

The response time to read the final data reduction results can be increased by associating the adjacent result register to build a result FIFO (see **Figure 16-21**). In this case, the final result of a data reduction sequence is loaded to the adjacent register. The value can be read from this register until the next data reduction sequence is finished (t8 in the 2nd example).



**Figure 16-21 Standard Data Reduction Filter with FIFO Enabled**

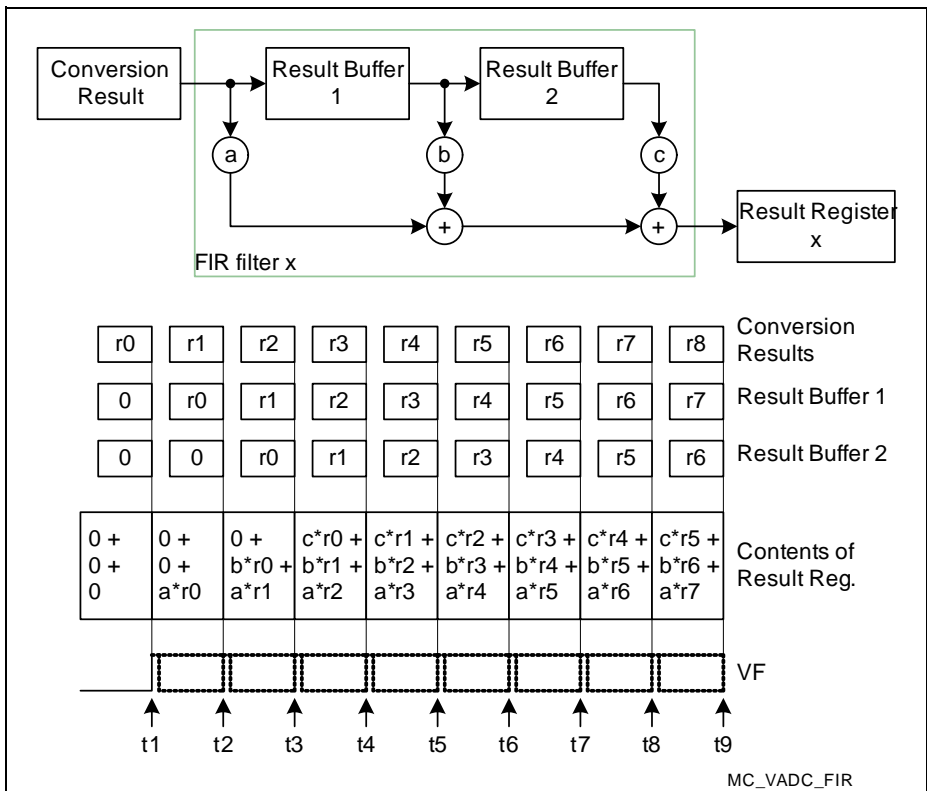
**Versatile Analog-to-Digital Converter (VADC)**

**Finite Impulse Response Filter Mode (FIR)**

The FIR filter (see [Figure 16-22](#)) provides 2 result buffers for intermediate results (RB1, RB2) and 3 configurable tap coefficients (a, b, c).

The conversion result and the intermediate result buffer values are added weighted with their respective coefficients to form the final value for the result register. Several predefined sets of coefficients can be selected via bitfield DRCTR (coding listed in [Table 16-5](#)) in registers **G0RESy (y = 0 - 15)** and **GLOBRES**. These coefficients lead to a gain of 3 or 4 to the ADC result producing a 14-bit value. The valid flag (VF) is activated for each sample after activation, i.e. for each sample it generates a valid result.

*Note: Conversions for other result registers can be inserted between conversions to be filtered.*



**Figure 16-22 FIR Filter Structure**

*Note: The filter registers are cleared while bitfield DMM ≠ 01<sub>B</sub>.*

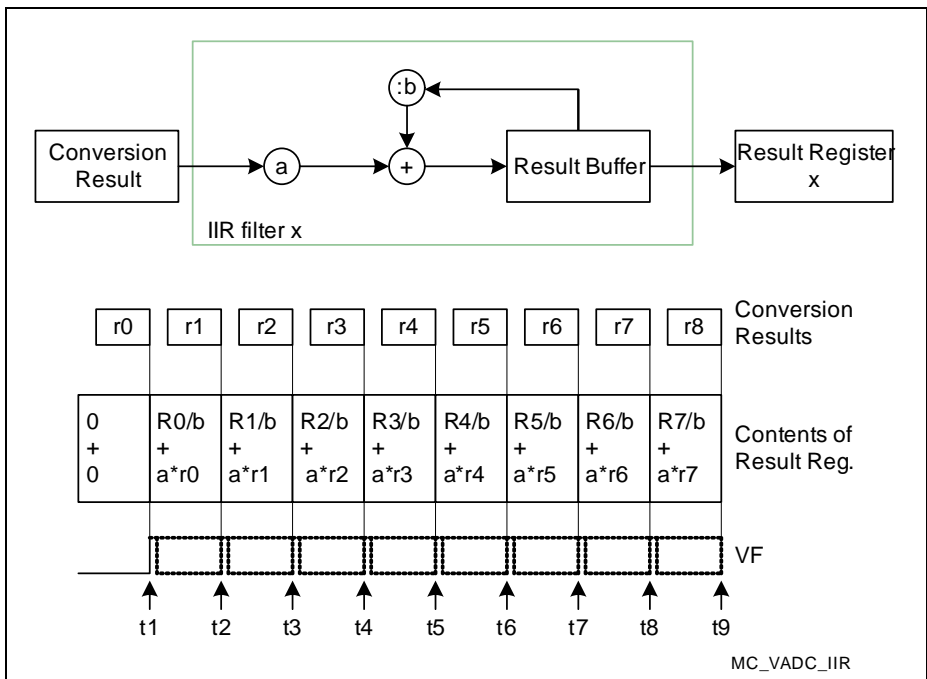
**Versatile Analog-to-Digital Converter (VADC)**

**Infinite Impulse Response Filter Mode (IIR)**

The IIR filter (see [Figure 16-23](#)) provides a result buffer (RB) and 2 configurable coefficients (a, b). It represents a first order low-pass filter.

The conversion result, weighted with the respective coefficient, and a fraction of the previous result are added to form the final value for the result register. Several predefined sets of coefficients can be selected via bitfield DRCTR (coding listed in [Table 16-5](#)) in registers **G0RESy (y = 0 - 15)** and **GLOBRES**. These coefficients lead to a gain of 4 to the ADC result producing a 14-bit value. The valid flag (VF) is activated for each sample after activation, i.e. for each sample generates a valid result.

*Note: Conversions for other result registers can be inserted between conversions to be filtered.*



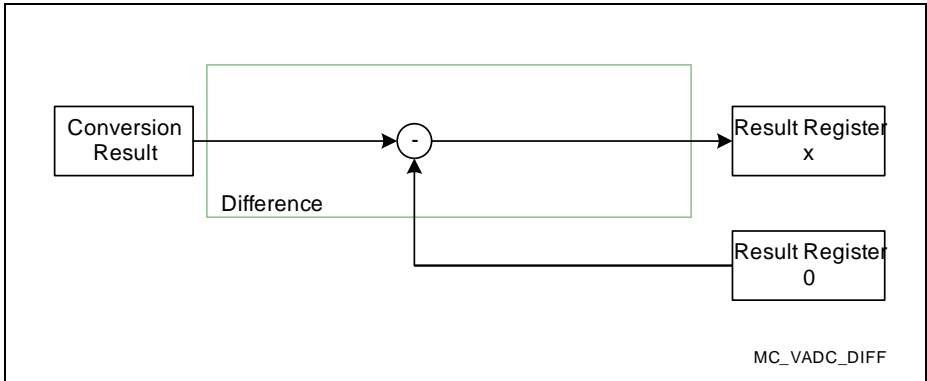
**Figure 16-23 IIR Filter Structure**

*Note: The filter registers are cleared while bitfield DMM ≠ 01<sub>B</sub>.*

**Difference Mode**

Subtracting the contents of result register 0 from the actual result puts the results of the respective channel in relation to another signal. No software action is required.

The reference channel must store its result(s) into result register 0. The reference value can be determined once and then be used for a series of conversions, or it can be converted before each related conversion.



**Figure 16-24 Result Difference**

## 16.12 Synchronization of Conversions

The conversions of an ADC kernel can be scheduled either self-timed according to the kernel's configuration or triggered by external (outside the ADC) signals:

**Synchronized conversions** support parallel conversion of channels within a synchronization group<sup>1)</sup>. This optimizes e.g. the control of electrical drives.

**Equidistant sampling** supports conversions in a fixed raster with minimum jitter. This optimizes e.g. filter algorithms or audio applications.

### 16.12.1 Synchronized Conversions for Parallel Sampling

Several independent ADC kernels<sup>1)</sup> implemented in the XMC1200 can be synchronized for simultaneous measurements of analog input channels. While no parallel conversion is requested, the kernels can work independently.

The synchronization mechanism for parallel conversions ensures that the sample phases of the related channels start simultaneously. Synchronized kernels convert the same channel that is requested by the master. Different values for the resolution and the sample phase length of each kernel for a parallel conversion are supported.

A parallel conversion can be requested individually for each input channel (one or more). In the example shown in [Figure 16-25](#), input channels CH3 of the ADC kernels 0 and 1 are converted synchronously, whereas other input channels do not lead to parallel conversions.

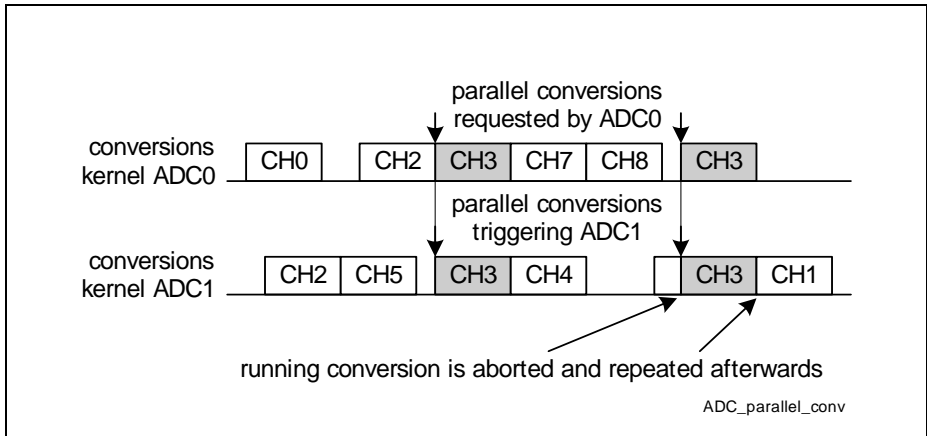
One kernel operates as synchronization master, the other kernel(s) operate(s) as synchronization slave. Each kernel can play either role. Master and slave kernels form a "conversion group" to control parallel sampling:

- **The synchronization master** ADC kernel can request a synchronized conversion of a certain channel (SYNC = 1 in the corresponding channel control register **GOCHCTRY** ( $y = 0 - 7$ ) etc.), which is also requested in the connected slave ADC kernel.  
Wait-for-read mode is supported for the master.
- **The synchronization slave** ADC kernel reacts to incoming synchronized conversion requests from the master. While no synchronized conversions are requested, the slave kernel can execute "local" conversions.
  - The slave timing must be configured according to the master timing (ARBRND in register **GxARBPR** ( $x = 0 - 1$ )) to enable parallel conversions.
  - A parallel conversion request is always handled with highest priority and cancel-inject-repeat mode.
  - Wait-for-read mode is ignored in the slave. Previous results may be overwritten, in particular, if the same result register is used by other conversions.

1) For a summary, please refer to ["Synchronization Groups in the XMC1200" on Page 16-152](#).

**Versatile Analog-to-Digital Converter (VADC)**

- The arbiter must run permanently (bit **GxARBPR (x = 0 - 1).ARBM = 0**) for the synchronization slave.  
Initialize the slave before the master to have the arbiters run synchronously.
- Once started, a parallel conversion cannot be aborted.



**Figure 16-25 Parallel Conversions**

The shown example uses synchronized conversions for channel CH3. The other channel conversions are controlled by their own kernels. ADC0 is the master, ADC1 is the slave.

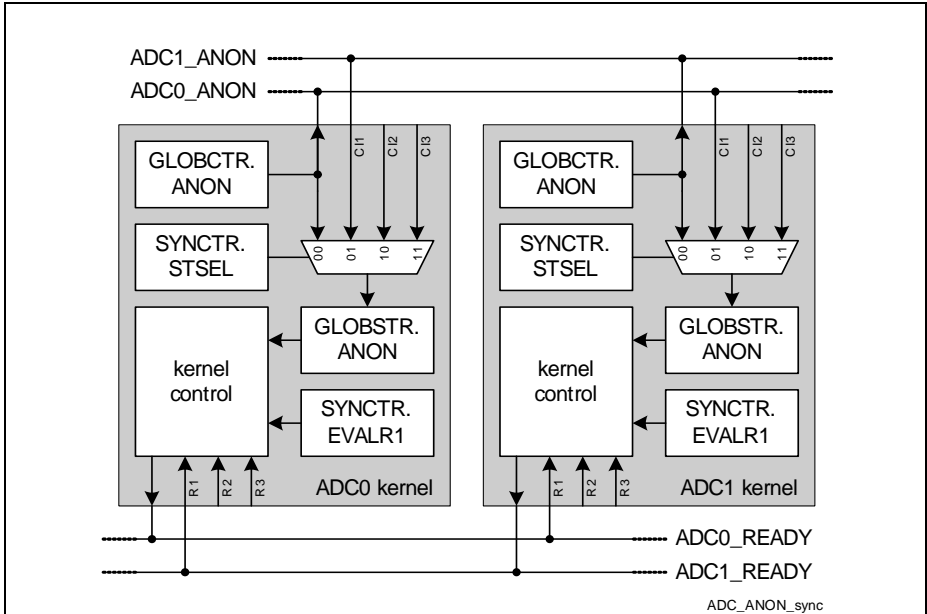
The synchronization master controls the slave by providing the control information **GxARBCFG (x = 0 - 1).ANONS** (see [Figure 16-26](#)) and the requested channel number. Bitfields **GxSYNCTR (x = 0 - 1).STSEL** select the source of the ANON information for the master ( $00_B$ ) and the slave(s) ( $01_B/10_B/11_B$ ).

**STSEL =  $00_B$**  always selects the own ANON information, and is, therefore, meant for the synchronization master or for stand-alone operation. The other control inputs (**STSEL =  $01_B/10_B/11_B$** ) are connected to the other kernels of a synchronization group in ascending order (see also [Table 16-13 “Synchronization Groups in the XMC1200” on Page 16-152](#)).

The ready signals indicate when a slave kernel is ready to start the sample phase of a parallel conversion. Bit **GxSYNCTR (x = 0 - 1).EVALR1 = 1** enables the control by the ready signal.

*Note: Synchronized conversions request the same channel number, defined by the master. Using the alias feature (see [Section 16.8.2](#)), analog signals from different input channels can be converted. This is advantageous if e.g. CH0 is used as alternate reference.*

**Versatile Analog-to-Digital Converter (VADC)**



**Figure 16-26 Synchronization via ANON and Ready Signals**



### 16.12.2 Equidistant Sampling

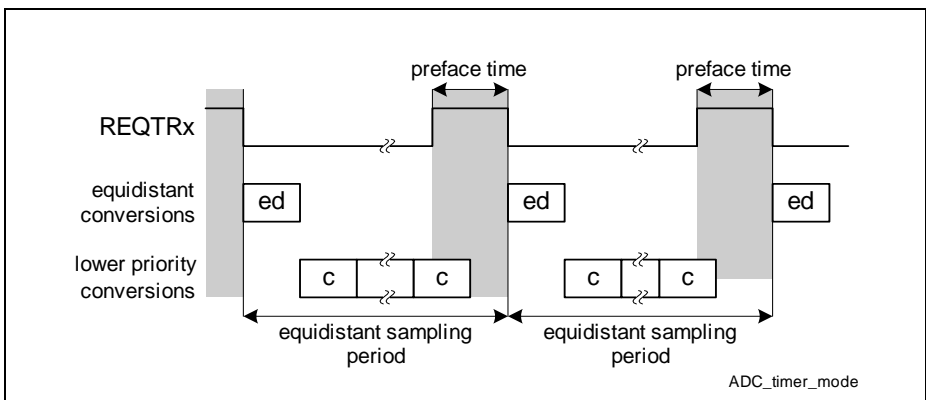
To optimize the input data e.g. for filter or audio applications, conversions can be executed in a fixed timing raster. Conversions for equidistant sampling are triggered by an external signal (e.g. a timer). To generate the trigger signal synchronous to the arbiter, the ADC provides an output signal (ARBCNT) that is activated once per arbitration round and serves as timing base for the trigger timer. In this case, the arbiter must run permanently (**GxARBPR (x = 0 - 1).ARBM = 0**). If the timer has an independent time base, the arbiter can be stopped while no requests are pending. The preface time (see **Figure 16-27**) must be longer than one arbitration round and the highest possible conversion time.

Select timer mode (TMEN = 1 in register **GxQCTRL0 (x = 0 - 1)** or **GxASCTRL (x = 0 - 1)**) for the intended source of equidistant conversions. In timer mode, a request of this source is triggered and arbitrated, but only started when the trigger signal is removed (see **Figure 16-27**) and the converter is idle.

To ensure that the converter is idle and the start of conversion can be controlled by the trigger signal, the equidistant conversion requests must receive highest priority. The preface time between request trigger and conversion start must be long enough for a currently active conversion to finish.

The frequency of signal REQTRx defines the sampling rate and its high time defines the preface time interval where the corresponding request source takes part in the arbitration.

Depending on the used request source, equidistant sampling is also supported for a sequence of channels. It is also possible to do equidistant sampling for more than one request source in parallel if the preface times and the equidistant conversions do not overlap.



**Figure 16-27 Timer Mode for Equidistant Sampling**

## 16.13 Safety Features

Several test features can be enabled to verify the validity of the analog input signals of an application.

- **Broken Wire Detection** validates the connection from the sensor to the input pin,
- **Multiplexer Diagnostics** validates the operation of the internal analog input multiplexer,

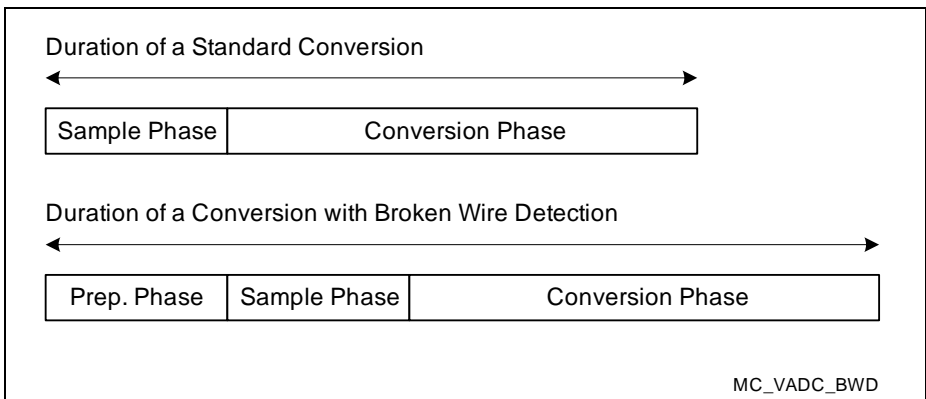
### 16.13.1 Broken Wire Detection

To test the proper connection of an external analog sensor to its input pin, the converter's capacitor can be precharged to a selectable value before the regular sample phase. If the connection to the sensor is interrupted the subsequent conversion value will rather represent the precharged value than the expected sensor result. By using a precharge voltage outside the expected result range (broken wire detection preferably uses  $V_{AGND}$  and/or  $V_{AREF}$ ) a valid measurement (sensor connected) can be distinguished from a failure (sensor detached).

While broken wire detection is disabled, the converter's capacitor is discharged.

*Note: The duration of the complete conversion is increased by the preparation phase (same as the sample phase) if the broken wire detection is enabled. This influences the timing of conversion sequences.*

Broken wire detection can be enabled for each channel separately by bitfield BW DEN in the corresponding channel control register (**G0CHCTry (y = 0 - 7)**). This bitfield also selects the level for the preparation phase.



**Figure 16-28 Broken Wire Detection**

### **16.13.2 Multiplexer Diagnostics**

Additional test structures (pull-ups, pull-downs) can be activated to test the signal path from the sensor to the input pin and the internal signal path from the input pin through the multiplexer to the converter. These pull devices apply additional loads to the signal path.

In combination with a known external input signal this test function shows if the multiplexer connects any pin to the converter input and if this is the correct pin.

The pull devices are activated via the standard port control registers.

**Versatile Analog-to-Digital Converter (VADC)**

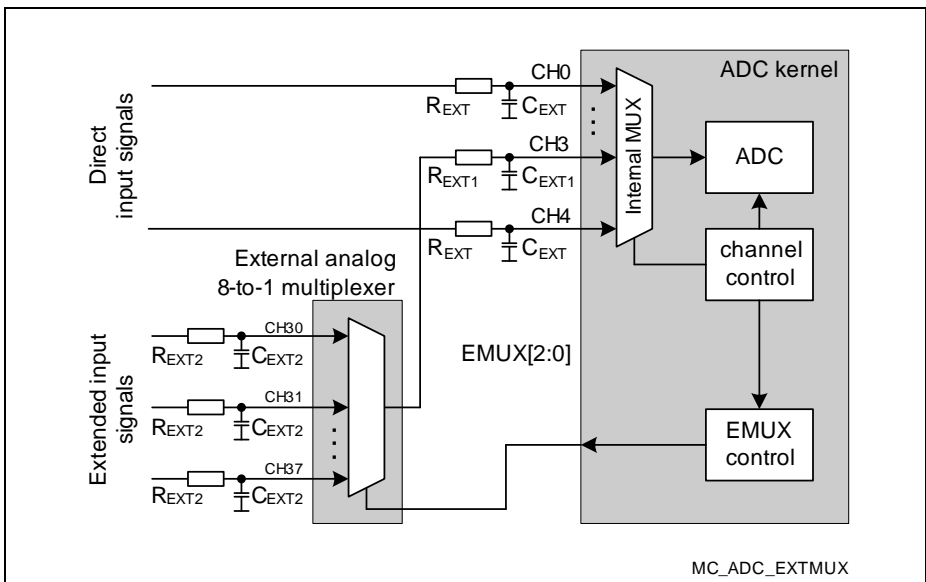
**16.14 External Multiplexer Control**

The number of analog input channels can be increased by connecting external analog multiplexers to an input channel. The ADC can be configured to control these external multiplexers automatically.

For each available EMUX interface (see register **EMUXSEL**) one channel can be selected for this operating mode. The ADC supports 1-out-of-8 multiplexers with several control options:

- **Sequence mode** automatically converts all configured external channels when the selected channel is encountered. In the example in **Figure 16-29** the following conversions are done: --4-32-31-30-2-1-0--4-32-31-30-2-1-0--...
- **Single-step mode** converts one external channel of the configured sequence when the selected channel is encountered. In the example in **Figure 16-29** the following conversions are done: --4-32-2-1-0--4-31-2-1-0--4-30-2-1-0--4-32-... (Single-step mode works best with one channel)
- **Steady mode** converts the configured external channel when the selected channel is encountered. In the example in **Figure 16-29** the following conversions are done: --4-32-2-1-0--4-32-2-1-0--4-32-2-1-0--...

*Note: The example in **Figure 16-29** has an external multiplexer connected to channel CH3. The start selection value **EMUXSET** is assumed as 2.*



**Figure 16-29 External Analog Multiplexer Example**

## Versatile Analog-to-Digital Converter (VADC)

Bitfield EMUXACT determines the control information sent to the external multiplexer. In single-step mode, EMUXACT is updated after each conversion of an enabled channel. If EMUXACT = 000<sub>B</sub> it is reloaded from bitfield EMUXSET, otherwise it is decremented by 1.

Additional external channels may have different properties due to the modified signal path. Local filters may be used at the additional inputs ( $R_{EXT2}$ - $C_{EXT2}$  on CH3x in [Figure 16-29](#)). For applications where the external multiplexer is located far from the ADC analog input, it is recommended to add an RC filter directly at the analog input of the ADC ( $R_{EXT1}$ - $C_{EXT1}$  on CH3 in [Figure 16-29](#)).

*Note: Each RC filter limits the bandwidth of the analog input signal.*

Conversions for external channels, therefore, use the alternate conversion mode setting CME. This automatically selects a different conversion mode if required.

Switching the external multiplexer usually requires an additional settling time for the input signal. Therefore, the alternate sample time setting STCE is applied each time the external channel is changed. This automatically fulfills the different sampling time requirements in this case.

In each group an arbitrary channel can be assigned to external multiplexer control (register **GxEMUXCTR (x = 0 - 1)**). Each available port interface selects the group whose control lines are output (register **EMUXSEL**).

### Control Signals

The external channel number that controls the external multiplexer can be output in standard binary format or Gray-coded. Gray code avoids intermediate multiplexer switching when selecting a sequence of channels, because only one bit changes at a time. [Table 16-6](#) indicates the resulting codes.

**Table 16-6 EMUX Control Signal Coding**

Channel	0	1	2	3	4	5	6	7
Binary	000 <sub>B</sub>	001 <sub>B</sub>	010 <sub>B</sub>	011 <sub>B</sub>	100 <sub>B</sub>	101 <sub>B</sub>	110 <sub>B</sub>	111 <sub>B</sub>
Gray	000	001	011	010	110	111	101	100

### Operation Without External Multiplexer

If no external multiplexers are used in an application, the reset values of the control registers provide the appropriate setup.

EMUXMODE = 00<sub>B</sub> disables the automatic EMUX control.

Since the control output signals are alternate port output signals, they are only visible at the respective pins if explicitly selected.

## 16.15 Service Request Generation

Each A/D Converter group can activate up to 4 group-specific service request output signals and up to 4 shared service request output signals. 2 group-specific and 2 shared request signals can issue an interrupt (see [Table 16-15 “Digital Connections in the XMC1200” on Page 16-154](#)).

Several events can be assigned to each service request output. Service requests can be generated by three types of events:

- **Request source events:** indicate that a request source completed the requested conversion sequence and the application software can initiate further actions. For a scan source (group or background), the event is generated when the complete defined set of channels (pending bits) has been converted. For a group queue source, the event is generated according to the programming, i.e. when a channel with enabled source interrupt has been converted or when an invalid entry is encountered.
- **Channel events:** indicate that a conversion is finished. Optionally, channel events can be restricted to result values within a programmable value range. This offloads the CPU from background tasks, i.e. a service request is only activated if the specified conversion result range is met or exceeded.
- **Result events:** indicate a new valid result in a result register. Usually, this triggers a read action by the CPU. Optionally, result events can be generated only at a reduced rate if data reduction is active.

Each ADC event is indicated by a dedicated flag that can be cleared by software. If a service request is enabled for a certain event, the service request is generated for each event, independent of the status of the corresponding event indication flag. This ensures that the ADC event can generate a service request without the need to clear the indication flag.

Event flag registers indicate all types of events that occur during the ADC's operation. Software can set each flag by writing a 1 to the respective position in register GxCEFLAG/GxRFLAG to trigger an event. Software can clear each flag by writing a 1 to the respective position in register GxCEFCLR/GxREFCLR. If enabled, service requests are generated for each occurrence of an event, even if the associated flag remains set.

### Node Pointer Registers

Requests from each event source can be directed to a set of service request nodes via associated node pointers. Requests from several sources can be directed to the same node; in this case, they are ORed to the service request output signal.

### **Software Service Request Activation**

Each service request can be activated via software by setting the corresponding bit in register **GxSRACT (x = 0 - 1)**. This can be used for evaluation and testing purposes.

*Note: For shared service request lines see common groups in **Table 16-12**.*

**Versatile Analog-to-Digital Converter (VADC)**

**16.16 Registers**

The Versatile ADC is built from a series of converter blocks that are controlled in an identical way. This makes programming versatile and scalable. The corresponding registers, therefore, have an individual offset assigned (see [Table 16-8](#)). The exact register location is obtained by adding the respective register offset to the base address (see [Table 16-7](#)) of the corresponding group.

Due to the regular group structure, several registers appear within each group. Other registers are provided for each channel. This is indicated in the register overview table by placeholders:

- $X###_H$  means:  $x \times 0400_H + 0###_H$ , for  $x = 0 - 1$
- $###Y_H$  means:  $###0_H + y \times 0004_H$ , for  $y = 0 - N$  (depends on register type)
- $Z###_H$  means:  $4803\ 4000_H + 0###_H$ , (SHS0)

**Table 16-7 Registers Address Space**

Module	Base Address	End Address	Note
VADC0	4803 0000 <sub>H</sub>	4803 0BFF <sub>H</sub>	

**Table 16-8 Registers Overview**

Register Short Name	Register Long Name	Offset Addr.	Access Mode		Page Num.
			Read	Write	
ID	Module Identification Register	0008 <sub>H</sub>	U, PV	BE	<a href="#">16-69</a>
CLC	Clock Control Register	0000 <sub>H</sub>	U, PV	PV	<a href="#">16-70</a>
OCS	OCDS Control and Status Register	0028 <sub>H</sub>	U, PV	PV	<a href="#">16-71</a>
GLOBCFG	Global Configuration Register	0080 <sub>H</sub>	U, PV	U, PV	<a href="#">16-73</a>
ACCPROT0	Access Protection Register 0	0088 <sub>H</sub>	U, PV	U, PV 1)	<a href="#">16-77</a>
ACCPROT1	Access Protection Register 1	008C <sub>H</sub>	U, PV	U, PV 1)	<a href="#">16-78</a>
GxARBCFG	Arbitration Configuration Register	X480 <sub>H</sub>	U, PV	U, PV	<a href="#">16-84</a>
GxARBPR	Arbitration Priority Register	X484 <sub>H</sub>	U, PV	U, PV	<a href="#">16-87</a>
GxCHASS	Channel Assignment Register, Group x	X488 <sub>H</sub>	U, PV	U, PV	<a href="#">16-80</a>
GxRRASS	Result Assignment Register, Group x	X48C <sub>H</sub>	U, SV	U, PV	<a href="#">16-81</a>
GxQCTRL0	Queue 0 Source Control Register, Group x	X500 <sub>H</sub>	U, PV	U, PV	<a href="#">16-88</a>



**Versatile Analog-to-Digital Converter (VADC)**
**Table 16-8 Registers Overview (cont'd)**

Register Short Name	Register Long Name	Offset Addr.	Access Mode		Page Num.
			Read	Write	
GxQMR0	Queue 0 Mode Register, Group x	X504 <sub>H</sub>	U, PV	U, PV	<a href="#">16-90</a>
GxQSR0	Queue 0 Status Register, Group x	X508 <sub>H</sub>	U, PV	U, PV	<a href="#">16-92</a>
GxQINR0	Queue 0 Input Register, Group x	X510 <sub>H</sub>	U, PV	U, PV	<a href="#">16-94</a>
GxQ0R0	Queue 0 Register 0, Group x	X50C <sub>H</sub>	U, PV	U, PV	<a href="#">16-96</a>
GxQBUR0	Queue 0 Backup Register, Group x	X510 <sub>H</sub>	U, PV	U, PV	<a href="#">16-98</a>
GxASCTRL	Autoscan Source Control Register, Group x	X520 <sub>H</sub>	U, PV	U, PV	<a href="#">16-100</a>
GxASMR	Autoscan Source Mode Register, Group x	X524 <sub>H</sub>	U, PV	U, PV	<a href="#">16-102</a>
GxASSEL	Autoscan Source Channel Select Register, Group x	X528 <sub>H</sub>	U, PV	U, PV	<a href="#">16-104</a>
GxASPND	Autoscan Source Pending Register, Group x	X52C <sub>H</sub>	U, PV	U, PV	<a href="#">16-105</a>
BRCTRL	Background Request Source Control Register	0200 <sub>H</sub>	U, PV	U, PV	<a href="#">16-106</a>
BRSMR	Background Request Source Mode Register	0204 <sub>H</sub>	U, PV	U, PV	<a href="#">16-108</a>
BRSELx	Background Request Source Channel Select Register, Group x	018Y <sub>H</sub>	U, PV	U, PV	<a href="#">16-110</a>
BRSPNDx	Background Request Source Channel Pending Register, Group x	01CY <sub>H</sub>	U, PV	U, PV	<a href="#">16-111</a>
GxCHCTry	Channel x Control Register	X60Y <sub>H</sub>	U, PV	U, PV	<a href="#">16-112</a>
GxICLASS0	Input Class Register 0, Group x	X4A0 <sub>H</sub>	U, PV	U, PV	<a href="#">16-114</a>
GxICLASS1	Input Class Register 1, Group x	X4A4 <sub>H</sub>	U, PV	U, PV	<a href="#">16-114</a>
GLOBICLASS0	Input Class Register 0, Global	00A0 <sub>H</sub>	U, PV	U, PV	<a href="#">16-114</a>
GLOBICLASS1	Input Class Register 1, Global	00A4 <sub>H</sub>	U, PV	U, PV	<a href="#">16-114</a>
GxALIAS	Alias Register	X4B0 <sub>H</sub>	U, PV	U, PV	<a href="#">16-128</a>

**Versatile Analog-to-Digital Converter (VADC)**

**Table 16-8 Registers Overview (cont'd)**

Register Short Name	Register Long Name	Offset Addr.	Access Mode		Page Num.
			Read	Write	
GxBOUND	Boundary Select Register, Group x	X4B8 <sub>H</sub>	U, PV	U, PV	<a href="#">16-130</a>
GLOBBOUND	Global Boundary Select Register	00B8 <sub>H</sub>	U, PV	U, PV	<a href="#">16-130</a>
GxBFL	Boundary Flag Register, Group x	X4C8 <sub>H</sub>	U, PV	U, PV	<a href="#">16-131</a>
GxBFLS	Boundary Flag Software Register, Group x	X4CC <sub>H</sub>	U, PV	U, PV	<a href="#">16-132</a>
GxBFLC	Boundary Flag Control Register, Group x	X4D0 <sub>H</sub>	U, PV	U, PV	<a href="#">16-133</a>
GxBFLNP	Boundary Flag Node Pointer Register, Group x	X4D4 <sub>H</sub>	U, PV	U, PV	<a href="#">16-134</a>
GxRCRy	Group x Result Control Register y	X68Y <sub>H</sub>	U, PV	U, PV	<a href="#">16-117</a>
GxRESy	Group x Result Register y	X70Y <sub>H</sub>	U, PV	U, PV	<a href="#">16-119</a>
GxRESyDy	Group x Result Register y (debug view)	X78Y <sub>H</sub>	U, PV	U, PV	<a href="#">16-120</a>
GLOBRCR	Global Result Control Register	0280 <sub>H</sub>	U, PV	U, PV	<a href="#">16-122</a>
GLOBRES	Global Result Register	0300 <sub>H</sub>	U, PV	U, PV	<a href="#">16-123</a>
GLOBRESD	Global Result Register (debug view)	0380 <sub>H</sub>	U, PV	U, PV	<a href="#">16-123</a>
GxVFR	Valid Flag Register, Group x	X5F8 <sub>H</sub>	U, PV	U, PV	<a href="#">16-124</a>
GxSYNCTR	Synchronization Control Register	X4C0 <sub>H</sub>	U, PV	U, PV	<a href="#">16-135</a>
GxEMUXCTR	External Multiplexer Control Register, Group x	X5F0 <sub>H</sub>	U, PV	U, PV	<a href="#">16-136</a>
EMUXSEL	External Multiplexer Select Register	03F0 <sub>H</sub>	U, PV	U, PV	<a href="#">16-138</a>

**Versatile Analog-to-Digital Converter (VADC)**
**Table 16-8 Registers Overview (cont'd)**

Register Short Name	Register Long Name	Offset Addr.	Access Mode		Page Num.
			Read	Write	
GxSEFLAG	Source Event Flag Register, Group x	X588 <sub>H</sub>	U, PV	U, PV	<a href="#">16-140</a>
GxCEFLAG	Channel Event Flag Register, Group x	X580 <sub>H</sub>	U, PV	U, PV	<a href="#">16-140</a>
GxREFLAG	Result Event Flag Register, Group x	X584 <sub>H</sub>	U, PV	U, PV	<a href="#">16-141</a>
GxSEFCLR	Source Event Flag Clear Register, Group x	X598 <sub>H</sub>	U, PV	U, PV	<a href="#">16-142</a>
GxCEFCLR	Channel Event Flag Clear Register, Group x	X590 <sub>H</sub>	U, PV	U, PV	<a href="#">16-142</a>
GxREFCLR	Result Event Flag Clear Register, Group x	X594 <sub>H</sub>	U, PV	U, PV	<a href="#">16-143</a>
GLOBEFLAG	Global Event Flag Register	00E0 <sub>H</sub>	U, PV	U, PV	<a href="#">16-143</a>
GxSEVNP	Source Event Node Pointer Register, Group x	X5C0 <sub>H</sub>	U, PV	U, PV	<a href="#">16-144</a>
GxCEVNP0	Channel Event Node Pointer Register 0, Group x	X5A0 <sub>H</sub>	U, PV	U, PV	<a href="#">16-145</a>
GxREVNP0	Result Event Node Pointer Register 0, Group x	X5B0 <sub>H</sub>	U, PV	U, PV	<a href="#">16-146</a>
GxREVNP1	Result Event Node Pointer Register 1, Group x	X5B4 <sub>H</sub>	U, PV	U, PV	<a href="#">16-147</a>
GLOBEVNP	Global Event Node Pointer Register	0140 <sub>H</sub>	U, PV	U, PV	<a href="#">16-148</a>
GxSRACT	Service Request Software Activation Trigger, Group x	X5C8 <sub>H</sub>	U, PV	U, PV	<a href="#">16-150</a>
ID	SHS Module Identification Register	Z008 <sub>H</sub>	U, SV	U, SV	<a href="#">16-69</a>
SHSCFG	SHS Configuration Register	Z040 <sub>H</sub>	U, SV	U, SV	<a href="#">16-74</a>
CALCTR	SHS Calibration Control Register	Z0BC <sub>H</sub>	U, SV	U, SV	<a href="#">16-125</a>
CALGC0	SHS Gain Calibration Control Reg.	Z0C0 <sub>H</sub>	U, SV	U, SV	<a href="#">16-127</a>

**Versatile Analog-to-Digital Converter (VADC)**

**Table 16-8 Registers Overview (cont'd)**

Register Short Name	Register Long Name	Offset Addr.	Access Mode		Page Num.
			Read	Write	
CALGC1	SHS Gain Calibration Control Reg.	Z0C4 <sub>H</sub>	U, SV	U, SV	<a href="#">16-127</a>
GNCTR00	Gain Control Register 0, S&H unit 0	Z180 <sub>H</sub>	U, SV	U, SV	<a href="#">16-128</a>
GNCTR10	Gain Control Register 0, S&H unit 1	Z190 <sub>H</sub>	U, SV	U, SV	<a href="#">16-128</a>
STEPCFG	SHS Stepper Configuration Register	Z044 <sub>H</sub>	U, SV	U, SV	<a href="#">16-82</a>
TIMCFG0	SHS Timing Configuration Register	Z080 <sub>H</sub>	U, SV	U, SV	<a href="#">16-83</a>
TIMCFG1	SHS Timing Configuration Register	Z084 <sub>H</sub>	U, SV	U, SV	<a href="#">16-83</a>
LOOP	SHS SD Loop Control Register	Z050 <sub>H</sub>	U, SV	U, SV	<a href="#">16-139</a>

1) Access to these registers is protected by bit protection scheme described in SCU chapter.

**Versatile Analog-to-Digital Converter (VADC)**

**16.16.1 Module Identification**

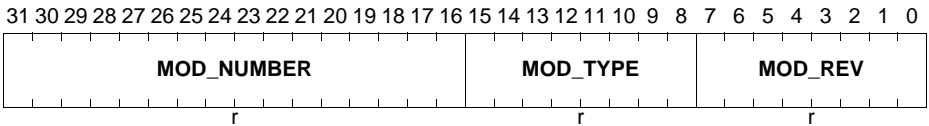
The module identification register indicates the version of the ADC module that is used in the XMC1200.

**ID**

**Module Identification Register (0008<sub>H</sub>)                      Reset Value: 00C5 C0XX<sub>H</sub>**

**SHS0\_ID**

**Module Identification Register (4803 4008<sub>H</sub>)                      Reset Value: 0099 C0XX<sub>H</sub>**



Field	Bits	Type	Description
<b>MOD_REV</b>	[7:0]	r	<b>Module Revision</b> Indicates the revision number of the implementation. This information depends on the design step.
<b>MOD_TYPE</b>	[15:8]	r	<b>Module Type</b> This internal marker is fixed to C0 <sub>H</sub> .
<b>MOD_NUMBER</b>	[31:16]	r	<b>Module Number</b> Indicates the module identification number (00C5 <sub>H</sub> = SARADC, 0099 <sub>H</sub> = SHS).

**Versatile Analog-to-Digital Converter (VADC)**

**16.16.2 System Registers**

A set of standardized registers provides general access to the module and controls basic system functions.

The Clock Control Register **CLC** allows the programmer to adapt the functionality and power consumption of the module to the requirements of the application. Register **CLC** controls the module clock signal and the reactivity to the sleep mode signal.

**CLC**

**Clock Control Register**

**(0000<sub>H</sub>)**

**Reset Value: 0000 0003<sub>H</sub>**

31	30	29	28	27	26	25	24	23	22	21	20	19	18	17	16
0	0	0	0	0	0	0	0	0	0	0	0	0	0	0	0
r	r	r	r	r	r	r	r	r	r	r	r	r	r	r	r
15	14	13	12	11	10	9	8	7	6	5	4	3	2	1	0
0	0	0	0	0	0	0	0	0	0	0	0	E DIS	0	DIS S	DIS R
r	r	r	r	r	r	r	r	r	r	r	r	rw	r	r	rw

Field	Bits	Type	Description
<b>DISR</b>	0	rw	<b>Module Disable Request Bit</b> Used for enable/disable control of the module. Also the analog section is disabled by clearing ANONS. 0 <sub>B</sub> On request: enable the module clock 1 <sub>B</sub> Off request: stop the module clock
<b>DISS</b>	1	r	<b>Module Disable Status Bit</b> 0 <sub>B</sub> Module clock is enabled 1 <sub>B</sub> Off: module is not clocked
<b>0</b>	2	r	<b>Reserved, write 0, read as 0</b>
<b>EDIS</b>	3	rw	<b>Sleep Mode Enable Control</b> Used to control module's reaction to sleep mode. 0 <sub>B</sub> Sleep mode request is enabled and functional 1 <sub>B</sub> Module disregards the sleep mode control signal
<b>0</b>	[31:4]	r	<b>Reserved, write 0, read as 0</b>

**Versatile Analog-to-Digital Converter (VADC)**

The OCDS control and status register OCS controls the module's behavior in suspend mode (used for debugging) and includes the module-related control bits for the OCDS Trigger Bus (OTGB).

The OCDS Control and Status (OCS) register is cleared by Debug Reset.

The OCS register can only be written when the OCDS is enabled.

If OCDS is being disabled, the OCS register value will not change.

When OCDS is disabled the OCS suspend control is ineffective.

Write access is 32 bit wide only and requires Supervisor Mode.

**OCS**

**OCDS Control and Status Register (0028<sub>H</sub>)**

**Reset Value: 0000 0000<sub>H</sub>**

31	30	29	28	27	26	25	24	23	22	21	20	19	18	17	16
0	0	SUS STA	SUS _P	SUS				0	0	0	0	0	0	0	0
r	r	rh	w	rw				r	r	r	r	r	r	r	r
15	14	13	12	11	10	9	8	7	6	5	4	3	2	1	0
0	0	0	0	0	0	0	0	0	0	0	0	TG _P	TGB	TGS	
r	r	r	r	r	r	r	r	r	r	r	r	w	rw	rw	

Field	Bits	Type	Description
<b>TGS</b>	[1:0]	rw	<b>Trigger Set for OTGB0/1</b> 00 <sub>B</sub> No Trigger Set output 01 <sub>B</sub> Trigger Set 1: TS16_SSIG, input sample signals 10 <sub>B</sub> Reserved 11 <sub>B</sub> Reserved
<b>TGB</b>	2	rw	<b>OTGB0/1 Bus Select</b> 0 <sub>B</sub> Trigger Set is output on OTGB0 1 <sub>B</sub> Trigger Set is output on OTGB1
<b>TG_P</b>	3	w	<b>TGS, TGB Write Protection</b> TGS and TGB are only written when TG_P is 1, otherwise unchanged. Read as 0.
<b>0</b>	[23:4]	r	<b>Reserved, write 0, read as 0</b>

**Versatile Analog-to-Digital Converter (VADC)**

Field	Bits	Type	Description
<b>SUS</b>	[27:24]	rw	<p><b>OCDS Suspend Control</b></p> <p>Controls the sensitivity to the suspend signal coming from the OCDS Trigger Switch (OTGS)</p> <p>0000<sub>B</sub> Will not suspend</p> <p>0001<sub>B</sub> Hard suspend: Clock is switched off immediately.</p> <p>0010<sub>B</sub> Soft suspend mode 0: Stop conversions after the currently running one is completed and its result has been stored. No change for the arbiter.</p> <p>0011<sub>B</sub> Soft suspend mode 1: Stop conversions after the currently running one is completed and its result has been stored. Stop arbiter after the current arbitration round.</p> <p>others: Reserved</p>
<b>SUS_P</b>	28	w	<p><b>SUS Write Protection</b></p> <p>SUS is only written when SUS_P is 1, otherwise unchanged. Read as 0.</p>
<b>SUSSTA</b>	29	rh	<p><b>Suspend State</b></p> <p>0<sub>B</sub> Module is not (yet) suspended</p> <p>1<sub>B</sub> Module is suspended</p>
<b>0</b>	[31:30]	r	<b>Reserved, write 0, read as 0</b>

**Table 16-9 TS16\_SSIG Trigger Set VADC**

Bits	Name	Description
[1:0]	GxSAMPLE	Input signal sample phase of converter group x (x = 1-0)
[15:2]	0	Reserved



**Versatile Analog-to-Digital Converter (VADC)**

**16.16.3 General Registers**

The global configuration register provides global control and configuration options that are valid for all converters of the cluster.

**GLOBCFG**

**Global Configuration Register (0080<sub>H</sub>)**      **Reset Value: 0000 000F<sub>H</sub>**

31	30	29	28	27	26	25	24	23	22	21	20	19	18	17	16	
SU CAL	0	0	0	0	0	0	0	0	0	0	0	0	0	DP CAL	DP CAL	
w	r	r	r	r	r	r	r	r	r	r	r	r	r	rw	rw	
15	14	13	12	11	10	9	8	7	6	5	4	3	2	1	0	
DIV WC	0	0	0	0	0	DIVD		DC MSB	0	0	DIVA					
w	r	r	r	r	r	rw		rw	r	r	rw					

Field	Bits	Type	Description
<b>DIVA</b>	[4:0]	rw	<b>Divider Factor for the Analog Internal Clock</b> Defines the frequency of the basic converter clock $f_{ADCI}$ (base clock for conversion and sample phase). 00 <sub>H</sub> $f_{ADCI} = f_{ADC}$ 01 <sub>H</sub> $f_{ADCI} = f_{ADC} / 2$ 02 <sub>H</sub> $f_{ADCI} = f_{ADC} / 3$ ... 1F <sub>H</sub> $f_{ADCI} = f_{ADC} / 32$
<b>0</b>	[6:5]	r	<b>Reserved, write 0, read as 0</b>
<b>DCMSB</b>	7	rw	<b>Double Clock for the MSB Conversion</b> Selects an additional clock cycle for the conversion step of the MSB. <sup>1)</sup> 0 <sub>B</sub> 1 clock cycles for the MSB (standard) 1 <sub>B</sub> 2 clock cycles for the MSB ( $f_{ADCI} > 20$ MHz)
<b>DIVD</b>	[9:8]	rw	<b>Divider Factor for the Arbiter Clock</b> Defines the frequency of the arbiter clock $f_{ADCD}$ . 00 <sub>B</sub> $f_{ADCD} = f_{ADC}$ 01 <sub>B</sub> $f_{ADCD} = f_{ADC} / 2$ 10 <sub>B</sub> $f_{ADCD} = f_{ADC} / 3$ 11 <sub>B</sub> $f_{ADCD} = f_{ADC} / 4$
<b>0</b>	[14:10]	r	<b>Reserved, write 0, read as 0</b>

**Versatile Analog-to-Digital Converter (VADC)**

Field	Bits	Type	Description
<b>DIVWC</b>	15	w	<b>Write Control for Divider Parameters</b> 0 <sub>B</sub> No write access to divider parameters 1 <sub>B</sub> Bitfields DIVA, DCMSB, DIVD can be written
<b>DPCALx</b> (x = 0 - 1)	x+16	rw	<b>Disable Post-Calibration</b> 0 <sub>B</sub> Automatic post-calibration after each conversion of group x 1 <sub>B</sub> No post-calibration <i>Note: This bit is only valid for the calibrated converters within the given product type.</i>
<b>0</b>	[30:18]	r	<b>Reserved, write 0, read as 0</b>
<b>SUCAL</b>	31	w	<b>Start-Up Calibration</b> The 0-1 transition of bit SUCAL initiates the start-up calibration phase of all calibrated analog converters. 0 <sub>B</sub> No action 1 <sub>B</sub> Initiate the start-up calibration phase (indication in bit GxARBCFG.CAL)

1) Please also refer to section **“Conversion Timing”** on Page 16-39.

**SHS0\_SHSCFG**

**SHS Configuration Register**

**(4803 4040<sub>H</sub>)**

**Reset Value: 0000 0000<sub>H</sub>**

31	30	29	28	27	26	25	24	23	22	21	20	19	18	17	16
STATE				TC				0	0	0	0	0	0	SP1	SP0
rh				rw				r	r	r	r	r	r	rh	rh
15	14	13	12	11	10	9	8	7	6	5	4	3	2	1	0
SC WC	AN RDY	0	AN OFF	AREF	0	0	0	0	0	0	DIVS				
w	rh	r	rw	rw	r	r	r	r	r	r	rw				

**Versatile Analog-to-Digital Converter (VADC)**

Field	Bits	Type	Description
<b>DIVS</b>	[3:0]	rw	<b>Divider Factor for the SHS Clock</b> Defines the frequency of the clock for the SHS logic and the SAR converter. $0000_{\text{B}} f_{\text{SH}} = f_{\text{CONV}} / 1$ $0001_{\text{B}} f_{\text{SH}} = f_{\text{CONV}} / 2$ ... $1111_{\text{B}} f_{\text{SH}} = f_{\text{CONV}} / 16$
<b>0</b>	[9:4]	r	<b>Reserved, write 0, read as 0</b>
<b>AREF</b>	[11:10]	rw	<b>Analog Reference Voltage Selection</b> $00_{\text{B}}$ External reference, upper supply range $01_{\text{B}}$ Reserved $10_{\text{B}}$ Reserved $11_{\text{B}}$ Reserved
<b>ANOFF</b>	12	rw	<b>Analog Converter Power Down Force<sup>1)</sup></b> $0_{\text{B}}$ Converter controlled by bitfields ANONS (digital control block) $1_{\text{B}}$ Converter is permanently off
<b>0</b>	13	r	<b>Reserved, write 0, read as 0</b>
<b>ANRDY</b>	14	rh	<b>Analog Converter Ready</b> $0_{\text{B}}$ Converter is in power-down mode $1_{\text{B}}$ Converter is operable
<b>SCWC</b>	15	w	<b>Write Control for SHS Configuration</b> $0_{\text{B}}$ No write access to SHS configuration $1_{\text{B}}$ Bitfields ANOFF, AREF, DIVS can be written
<b>SP0, SP1</b>	16, 17	rh	<b>Sample Pending on S&amp;H Unit x</b> $0_{\text{B}}$ No sample pending $1_{\text{B}}$ S&H unit x has finished the sample phase
<b>0</b>	[23:18]	r	<b>Reserved, write 0, read as 0</b>
<b>TC</b>	[27:24]	rw	<b>Test Control</b> $1011_{\text{B}}$ Internal test functions enabled Others: Normal operation <i>Note: Make sure to write <math>0000_{\text{B}}</math> to this bitfield for normal operation.</i>

**Versatile Analog-to-Digital Converter (VADC)**

Field	Bits	Type	Description
<b>STATE</b>	[31:28]	rh	<b>Current State of Sequencer</b> 0000 <sub>B</sub> Idle 0001 <sub>B</sub> Offset calibration active 0010 <sub>B</sub> Gain calibration active 0011 <sub>B</sub> Startup calibration active 1000 <sub>B</sub> Stepper process active for S&H unit 0 1001 <sub>B</sub> Stepper process active for S&H unit 1 Others: Normal operation

1) See also "[Analog Converter Control](#)" on [Page 16-14](#).

**Versatile Analog-to-Digital Converter (VADC)**

**Register Access Control**

Several protection schemes are provided to prevent unintended write access to control bitfields of the VADC.

**ACCPROT0**

**Access Protection Register (0088<sub>H</sub>)** **Reset Value: 0000 0000<sub>H</sub>**

31	30	29	28	27	26	25	24	23	22	21	20	19	18	17	16
<b>AP GC</b>	<b>0</b>	<b>0</b>	<b>0</b>	<b>0</b>	<b>0</b>	<b>0</b>	<b>0</b>	<b>0</b>	<b>0</b>	<b>0</b>	<b>0</b>	<b>0</b>	<b>0</b>	<b>AP I1</b>	<b>AP I0</b>
rw	r	r	r	r	r	r	r	r	r	r	r	r	r	rw	rw
15	14	13	12	11	10	9	8	7	6	5	4	3	2	1	0
<b>AP EM</b>	<b>0</b>	<b>0</b>	<b>0</b>	<b>0</b>	<b>0</b>	<b>0</b>	<b>0</b>	<b>0</b>	<b>0</b>	<b>0</b>	<b>0</b>	<b>0</b>	<b>0</b>	<b>AP C1</b>	<b>AP C0</b>
rw	r	r	r	r	r	r	r	r	r	r	r	r	r	rw	rw

Field	Bits	Type	Description
<b>APC0, APC1</b>	0, 1	rw	<b>Access Protection Channel Control, Group 0 - 1</b> 0 <sub>B</sub> Full access to registers 1 <sub>B</sub> Write access to channel control registers is blocked
<b>0</b>	[14:2]	r	<b>Reserved, write 0, read as 0</b>
<b>APEM</b>	15	rw	<b>Access Protection External Multiplexer</b> 0 <sub>B</sub> Full access to registers 1 <sub>B</sub> Write access to external multiplexer registers is blocked
<b>API0, API1</b>	16, 17	rw	<b>Access Protection Initialization, Group 0 - 1</b> 0 <sub>B</sub> Full access to registers 1 <sub>B</sub> Write access to initialization registers is blocked
<b>0</b>	[30:18]	r	<b>Reserved, write 0, read as 0</b>
<b>APGC</b>	31	rw	<b>Access Protection Global Configuration</b> 0 <sub>B</sub> Full access to register 1 <sub>B</sub> Write access to global configuration register is blocked

**Versatile Analog-to-Digital Converter (VADC)**

**ACCPROT1**

**Access Protection Register**

**(008C<sub>H</sub>)**

**Reset Value: 0000 0000<sub>H</sub>**

31	30	29	28	27	26	25	24	23	22	21	20	19	18	17	16
0	0	0	0	0	0	0	0	0	0	0	0	0	0	AP R1	AP R0
r	r	r	r	r	r	r	r	r	r	r	r	r	r	rw	rw
15	14	13	12	11	10	9	8	7	6	5	4	3	2	1	0
AP TF	0	0	0	0	0	0	0	0	0	0	0	0	0	AP S1	AP S0
rw	r	r	r	r	r	r	r	r	r	r	r	r	r	rw	rw

Field	Bits	Type	Description
<b>APS0, APS1</b>	0, 1	rw	<b>Access Protection Service Request, Group 0 - 1</b> 0 <sub>B</sub> Full access to registers 1 <sub>B</sub> Write access to service request registers is blocked
<b>0</b>	[14:2]	r	<b>Reserved, write 0, read as 0</b>
<b>APTF</b>	15	rw	<b>Access Protection Test Function</b> 0 <sub>B</sub> Full access to register 1 <sub>B</sub> Write access to test function register is blocked
<b>APR0, APR1</b>	16, 17	rw	<b>Access Protection Result Registers, Group 0 - 1</b> 0 <sub>B</sub> Full access to registers 1 <sub>B</sub> Write access to result registers is blocked
<b>0</b>	[31:18]	r	<b>Reserved, write 0, read as 0</b>

**Table 16-10 Register Protection Groups**

Control Bits	Registers	Notes
APCx	GxCHCTR0 ... GxCHCTRy	Channel control
APEM	EMUXSEL, GxEMUXCTR	External multiplexer control
APIx	GxARBCFG, GxARBPR, GxCHASS, GxRRASS, GxICLASS0/1, GxSYNCTR	Initialization
APGC	GLOBCFG	Global configuration

**Versatile Analog-to-Digital Converter (VADC)**

**Table 16-10 Register Protection Groups (cont'd)**

<b>Control Bits</b>	<b>Registers</b>	<b>Notes</b>
APSt	GxSEFLAG, GxSEVNP, GxCEFLAG, GxCEVNP0/1, GxREFLAG, GxREVNP0/1, GxSRACT	Service request control
APTF	-	Test functions
APRx	GxRCR0 ... GxRCR15, GxBOUND, GxRES0 ... GxRES15	Result control

**Versatile Analog-to-Digital Converter (VADC)**

**Priority Channel Assignment**

Each channel of a group can be assigned to this group's request sources and is then regarded as a priority channel. An assigned priority channel can only be converted by its own group's request sources. A not assigned channel can also be converted by the background request source.

**GxCHASS (x = 0 - 1)**

**Channel Assignment Register, Group x**

$$(x * 0400_H + 0488_H)$$

**Reset Value: 0000 0000\_H**

31	30	29	28	27	26	25	24	23	22	21	20	19	18	17	16
0	0	0	0	0	0	0	0	0	0	0	0	0	0	0	0
r	r	r	r	r	r	r	r	r	r	r	r	r	r	r	r
15	14	13	12	11	10	9	8	7	6	5	4	3	2	1	0
0	0	0	0	0	0	0	0	ASS CH 7	ASS CH 6	ASS CH 5	ASS CH 4	ASS CH 3	ASS CH 2	ASS CH 1	ASS CH 0
r	r	r	r	r	r	r	r	rW	rW	rW	rW	rW	rW	rW	rW

Field	Bits	Type	Description
<b>ASSCH<sub>y</sub></b> <b>(y = 0 - 7)</b>	y	rw	<b>Assignment for Channel y</b> 0 <sub>B</sub> Channel y can be a background channel converted with lowest priority 1 <sub>B</sub> Channel y is a priority channel within group x
<b>0</b>	[31:8]	r	<b>Reserved, write 0, read as 0</b>



**Versatile Analog-to-Digital Converter (VADC)**

**Priority Result Register Assignment**

Each result register of a group can be assigned to this group's request sources and is then regarded as a reserved resource. An assigned result register can only be written by its own group's request sources. A not assigned result register can also be written by the background request source.

**GxRRASS (x = 0 - 1)**

**Result Assignment Register, Group x**

(x \* 0400<sub>H</sub> + 048C<sub>H</sub>)

Reset Value: 0000 0000<sub>H</sub>

31	30	29	28	27	26	25	24	23	22	21	20	19	18	17	16
0	0	0	0	0	0	0	0	0	0	0	0	0	0	0	0
r	r	r	r	r	r	r	r	r	r	r	r	r	r	r	r
15	14	13	12	11	10	9	8	7	6	5	4	3	2	1	0
ASS RR 15	ASS RR 14	ASS RR 13	ASS RR 12	ASS RR 11	ASS RR 10	ASS RR 9	ASS RR 8	ASS RR 7	ASS RR 6	ASS RR 5	ASS RR 4	ASS RR 3	ASS RR 2	ASS RR 1	ASS RR 0
rW	rW	rW	rW	rW	rW	rW	rW	rW	rW	rW	rW	rW	rW	rW	rW

Field	Bits	Type	Description
<b>ASSRRy</b> <b>(y = 0 - 15)</b>	y	rw	<b>Assignment for Result Register y</b> 0 <sub>B</sub> Result register y can also be written by the background source 1 <sub>B</sub> Result register y can only be written by sources within group x
<b>0</b>	[31:16]	r	<b>Reserved, write 0, read as 0</b>

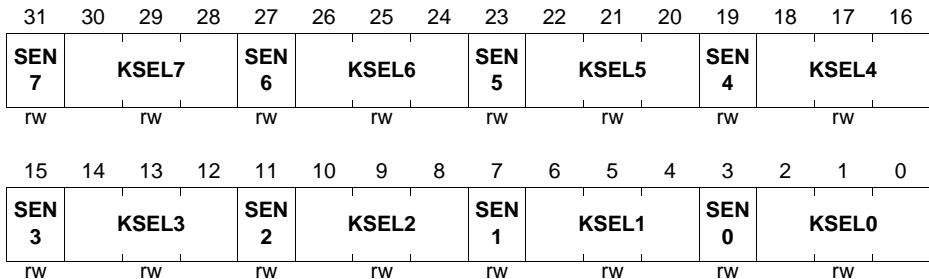
**Versatile Analog-to-Digital Converter (VADC)**

The stepper configuration register selects the S&H unit that is serviced during each step of the stepper state machine.

**SHS0\_STEPCFG**

**Stepper Configuration Register (4803 4044<sub>H</sub>)**

**Reset Value: 0000 0098<sub>H</sub>**



Field	Bits	Type	Description
<b>KSEL0,</b> <b>KSEL1,</b> <b>KSEL2,</b> <b>KSEL3,</b> <b>KSEL4,</b> <b>KSEL5,</b> <b>KSEL6,</b> <b>KSEL7</b>	[2:0], [6:4], [10:8], [14:12], [18:16], [22:20], [26:24], [30:28]	rw	<b>Kernel Select</b> Defines the group (i.e. the S&H unit) that is served during this step. The valid values depend on the number of supported kernels/interfaces: 0 ... 1
<b>SEN0,</b> <b>SEN1,</b> <b>SEN2,</b> <b>SEN3,</b> <b>SEN4,</b> <b>SEN5,</b> <b>SEN6,</b> <b>SEN7</b>	3, 7, 11, 15, 19, 23, 27, 31	rw	<b>Step x Enable</b> Defines if or not this step is executed. 0 <sub>B</sub> Off: This step is not part of the stepper sequence 1 <sub>B</sub> Active: This step is executed during the sequence

**Versatile Analog-to-Digital Converter (VADC)**

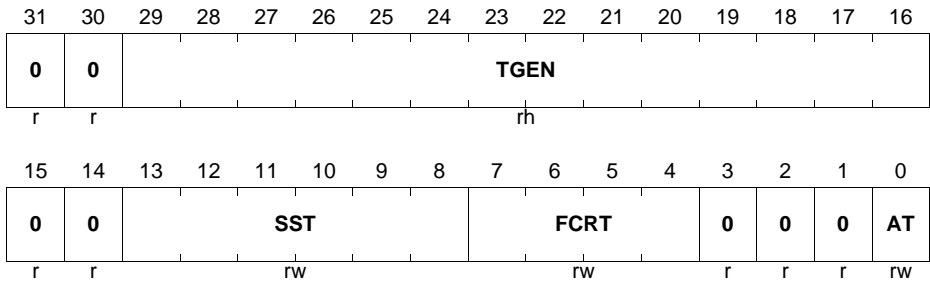
The timing configuration register TIMCFGx configures the interface timing of the SHS.

**SHS0\_TIMCFGx (x = 0 - 1)**

**Timing Configuration Register x**

$$(4803\ 4080_H + x * 4_H)$$

**Reset Value: 0000 0001<sub>H</sub>**



Field	Bits	Type	Description
<b>AT</b>	0	rw	<b>Accelerated Timing</b> Enables the enhanced conversion timing scheme. 0 <sub>B</sub> Compatible timing: Result available after standard conversion time 1 <sub>B</sub> Accelerated timing: Result available as soon as converted
<b>0</b>	[3:1]	r	<b>Reserved, write 0, read as 0</b>
<b>FCRT</b>	[7:4]	rw	<b>Fast Compare Mode Response Time</b> Defines the duration of a fast compare operation. A result is generated after (FCRT+1) × 2 × t <sub>ADCl</sub> . 0 <sub>H</sub> Result after t <sub>ADCl</sub> × 2 ... F <sub>H</sub> Result after t <sub>ADCl</sub> × 32
<b>SST</b>	[13:8]	rw	<b>Short Sample Time</b> Defines the duration of the sample phase. 00 <sub>H</sub> Compatible timing: Sample time is defined by DIVA and STC. 01 <sub>H</sub> Sample time is t <sub>ADC</sub> × 1 3F <sub>H</sub> Sample time is t <sub>ADC</sub> × 63
<b>0</b>	[15:14]	r	<b>Reserved, write 0, read as 0</b>

**Versatile Analog-to-Digital Converter (VADC)**

Field	Bits	Type	Description
<b>TGEN</b>	[29:16]	rh	<b>Timing Generator</b> Counts the duration of the sample phase, and the conversion in compatible timing mode.
<b>0</b>	[31:30]	r	<b>Reserved, write 0, read as 0</b>

### 16.16.4 Arbitration and Source Registers

The Arbitration Configuration Register selects the timing and the behavior of the arbiter.

**GxARBCFG (x = 0 - 1)**

**Arbitration Configuration Register, Group x**

(x \* 0400<sub>H</sub> + 0480<sub>H</sub>)

**Reset Value: 0000 0000<sub>H</sub>**

31	30	29	28	27	26	25	24	23	22	21	20	19	18	17	16
<b>SAMPLE</b>	<b>BU SY</b>	<b>CAL S</b>	<b>CAL</b>	<b>0</b>	<b>0</b>	<b>SYN RUN</b>	<b>CHNR</b>				<b>CSRC</b>			<b>ANONS</b>	
rh	rh	rh	rh	r	r	rh	rh				rh			rh	
15	14	13	12	11	10	9	8	7	6	5	4	3	2	1	0
<b>0</b>	<b>0</b>	<b>0</b>	<b>0</b>	<b>0</b>	<b>0</b>	<b>0</b>	<b>0</b>	<b>ARB M</b>	<b>0</b>	<b>ARBRND</b>		<b>0</b>	<b>0</b>	<b>ANONC</b>	
r	r	r	r	r	r	r	r	rw	r	rw		r	r	rw	

Field	Bits	Type	Description
<b>ANONC</b>	[1:0]	rw	<b>Analog Converter Control</b> Defines the value of bitfield ANONS in a stand-alone converter or a converter in master mode. Coding see ANONS or <a href="#">Section 16.5</a> .
<b>0</b>	[3:2]	r	<b>Reserved, write 0, read as 0</b>
<b>ARBRND</b>	[5:4]	rw	<b>Arbitration Round Length</b> Defines the number of arbitration slots per arb. round (arbitration round length = $t_{ARB}$ ). <sup>1)</sup> 00 <sub>B</sub> 4 arbitration slots per round ( $t_{ARB} = 4 / f_{ADCD}$ ) 01 <sub>B</sub> 8 arbitration slots per round ( $t_{ARB} = 8 / f_{ADCD}$ ) 10 <sub>B</sub> 16 arbitration slots per round ( $t_{ARB} = 16 / f_{ADCD}$ ) 11 <sub>B</sub> 20 arbitration slots per round ( $t_{ARB} = 20 / f_{ADCD}$ )
<b>0</b>	6	r	<b>Reserved, write 0, read as 0</b>

**Versatile Analog-to-Digital Converter (VADC)**

Field	Bits	Type	Description
<b>ARBM</b>	7	rw	<p><b>Arbitration Mode</b></p> <p>0<sub>B</sub> The arbiter runs permanently. This setting is required for a synchronization slave (see <a href="#">Section 16.12.1</a>) and for equidistant sampling using the signal ARBCNT (see <a href="#">Section 16.12.2</a>).</p> <p>1<sub>B</sub> The arbiter only runs if at least one conversion request of an enabled request source is pending. This setting ensures a reproducible latency from an incoming request to the conversion start, if the converter is idle. Synchronized conversions are not supported.</p>
<b>0</b>	[15:8]	r	<b>Reserved, write 0, read as 0</b>
<b>ANONS</b>	[17:16]	rh	<p><b>Analog Converter Control Status</b></p> <p>Defined by bitfield ANONC in a stand-alone kernel or a kernel in master mode. In slave mode, this bitfield is defined by bitfield ANONC of the respective master kernel. See also <a href="#">Section 16.5</a>.</p> <p>00<sub>B</sub> Analog converter off  01<sub>B</sub> Reserved  10<sub>B</sub> Slow standby mode  11<sub>B</sub> Normal operation (permanently on)</p>
<b>CSRC</b>	[19:18]	rh	<p><b>Currently Converted Request Source</b></p> <p>Indicates the arbitration slot number of the current (BUSY = 1) or of the last (BUSY = 0) conversion. This bitfield is updated when a conversion is started.</p> <p>00<sub>B</sub> Current/last conversion for request source 0  01<sub>B</sub> Current/last conversion for request source 1  10<sub>B</sub> Current/last conversion for background source  11<sub>B</sub> Current/last conversion for synchronization request (slave converter)  Other combinations are reserved.</p>
<b>CHNR</b>	[24:20]	rh	<p><b>Channel Number</b></p> <p>Indicates the current or last converted analog input channel. This bitfield is updated when a conversion is started.</p>

**Versatile Analog-to-Digital Converter (VADC)**

Field	Bits	Type	Description
<b>SYNRUN</b>	25	rh	<b>Synchronous Conversion Running</b> Indicates that a synchronized (= parallel) conversion is currently running. $0_B$ Normal conversion or no conversion running $1_B$ A synchronized conversion is running (cannot be cancelled by higher priority requests!)
<b>0</b>	[27:26]	r	<b>Reserved, write 0, read as 0</b>
<b>CAL</b>	28	rh	<b>Start-Up Calibration Active Indication</b> Indicates the start-up calibration phase of the corresponding analog converter. $0_B$ Completed or not yet started $1_B$ Start-up calibration phase is active (set one clock cycle after setting bit SUCAL) <i>Note: Start conversions only after the start-up calibration phase is complete.<sup>2)</sup></i>
<b>CALS</b>	29	rh	<b>Start-Up Calibration Started</b> Indicates that the start-up calibration has begun. $0_B$ Requested but not yet started $1_B$ Start-up calibration has begun <i>Note: Bit CALS is cleared when setting bit SUCAL and is set together with bit CAL.</i>
<b>BUSY</b>	30	rh	<b>Converter Busy Flag</b> $0_B$ Not busy $1_B$ Converter is busy with a conversion
<b>SAMPLE</b>	31	rh	<b>Sample Phase Flag</b> $0_B$ Converting or idle $1_B$ Input signal is currently sampled

- 1) The default setting of 4 arbitration slots is sufficient for correct arbitration. The duration of an arbitration round can be increased if required to synchronize requests.
- 2) The completion of the start-up calibration is indicated by CAL = 0 AND CALS = 1.  
CAL = CALS = 0 indicates that the start-up calibration was requested but has not yet begun.  
CAL = CALS = 1 indicates an ongoing calibration phase.

The Arbitration Priority Register defines the request source priority and the conversion start mode for each request source.

*Note: Only change priority and conversion start mode settings of a request source while this request source is disabled, and a currently running conversion requested by this source is finished.*

**Versatile Analog-to-Digital Converter (VADC)**

**GxARBPR (x = 0 - 1)**

**Arbitration Priority Register, Group x**

$$(x * 0400_H + 0484_H)$$

**Reset Value: 0000 0000<sub>H</sub>**

31	30	29	28	27	26	25	24	23	22	21	20	19	18	17	16
0	0	0	0	0	AS EN2	AS EN1	AS EN0	0	0	0	0	0	0	0	0
r	r	r	r	r	rw	rw	rw	r	r	r	r	r	r	r	r
15	14	13	12	11	10	9	8	7	6	5	4	3	2	1	0
0	0	0	0	CSM 2	0	PRIO 2	CSM 1	0	PRIO 1	CSM 0	0	PRIO 0	0	PRIO 0	0
r	r	r	r	rw	r	rw	rw	r	rw	rw	r	rw	r	rw	r

Field	Bits	Type	Description
<b>PRIO0, PRIO1, PRIO2</b>	[1:0], [5:4], [9:8]	rw	<b>Priority of Request Source x</b> Arbitration priority of request source x (in slot x) 00 <sub>B</sub> Lowest priority is selected. ... 11 <sub>B</sub> Highest priority is selected.
<b>CSM0, CSM1, CSM2</b>	3, 7, 11	rw	<b>Conversion Start Mode of Request Source x</b> 0 <sub>B</sub> Wait-for-start mode 1 <sub>B</sub> Cancel-inject-repeat mode, i.e. this source can cancel conversion of other sources.
<b>0</b>	2, 6, 10, [23:12]	r	<b>Reserved, write 0, read as 0</b>
<b>ASENy (y = 0 - 2)</b>	24 + y	rw	<b>Arbitration Slot y Enable</b> Enables the associated arbitration slot of an arbiter round. The request source bits are not modified by write actions to ASENr. 0 <sub>B</sub> The corresponding arbitration slot is disabled and considered as empty. Pending conversion requests from the associated request source are disregarded. 1 <sub>B</sub> The corresponding arbitration slot is enabled. Pending conversion requests from the associated request source are arbitrated.
<b>0</b>	[31:27]	r	<b>Reserved, write 0, read as 0</b>

**Versatile Analog-to-Digital Converter (VADC)**

The control register of the queue source selects the external gate and/or trigger signals. Write control bits allow separate control of each function with a simple write access.

**GxQCTRL0 (x = 0 - 1)**

**Queue 0 Source Control Register, Group x**

$(x * 0400_H + 0500_H)$

**Reset Value: 0000 0000<sub>H</sub>**

31	30	29	28	27	26	25	24	23	22	21	20	19	18	17	16	
<b>TM</b>	<b>0</b>	<b>0</b>	<b>TM</b>	<b>0</b>	<b>0</b>	<b>0</b>	<b>0</b>	<b>GT</b>	<b>0</b>	<b>0</b>	<b>GT</b>	<b>GT</b>				
<b>WC</b>			<b>EN</b>					<b>WC</b>			<b>LVL</b>	<b>SEL</b>				
w	r	r	rw	r	r	r	r	w	r	r	rh	rw				
15	14	13	12	11	10	9	8	7	6	5	4	3	2	1	0	
<b>XT</b>	<b>XT</b>		<b>XT</b>	<b>XT</b>			<b>0</b>		<b>0</b>	<b>0</b>	<b>0</b>	<b>SRCRESREG</b>				
<b>WC</b>	<b>MODE</b>		<b>LVL</b>	<b>SEL</b>					r	r	r	r	rwr			
w	rw		rh	rw					r	r	r	r	rwr			

Field	Bits	Type	Description
<b>SRCRESREG</b>	[3:0]	rw	<b>Source-specific Result Register</b> 0000 <sub>B</sub> Use GxCHCTry.RESREG to select a group result register 0001 <sub>B</sub> Store result in group result register GxRES1 ... 1111 <sub>B</sub> Store result in group result register GxRES15
<b>0</b>	[7:4]	r	<b>Reserved, write 0, read as 0</b>
<b>XTSEL</b>	[11:8]	rw	<b>External Trigger Input Selection</b> The connected trigger input signals are listed in <a href="#">Table 16-15 “Digital Connections in the XMC1200” on Page 16-154</a> <i>Note: XTSEL = 1111<sub>B</sub> uses the selected gate input as trigger source (ENG must be 0x<sub>B</sub>).</i>
<b>XTLVL</b>	12	rh	<b>External Trigger Level</b> Current level of the selected trigger input
<b>XTMODE</b>	[14:13]	rw	<b>Trigger Operating Mode</b> 00 <sub>B</sub> No external trigger 01 <sub>B</sub> Trigger event upon a falling edge 10 <sub>B</sub> Trigger event upon a rising edge 11 <sub>B</sub> Trigger event upon any edge



**Versatile Analog-to-Digital Converter (VADC)**

Field	Bits	Type	Description
<b>XTWC</b>	15	w	<b>Write Control for Trigger Configuration</b> 0 <sub>B</sub> No write access to trigger configuration 1 <sub>B</sub> Bitfields XTMODE and XTSEL can be written
<b>GTSEL</b>	[19:16]	rw	<b>Gate Input Selection</b> The connected gate input signals are listed in <a href="#">Table 16-15 “Digital Connections in the XMC1200” on Page 16-154</a>
<b>GTLVL</b>	20	rh	<b>Gate Input Level</b> Current level of the selected gate input
<b>0</b>	[22:21]	r	<b>Reserved, write 0, read as 0</b>
<b>GTWC</b>	23	w	<b>Write Control for Gate Configuration</b> 0 <sub>B</sub> No write access to gate configuration 1 <sub>B</sub> Bitfield GTSEL can be written
<b>0</b>	[27:24]	r	<b>Reserved, write 0, read as 0</b>
<b>TMEN</b>	28	rw	<b>Timer Mode Enable</b> 0 <sub>B</sub> No timer mode: standard gating mechanism can be used 1 <sub>B</sub> Timer mode for equidistant sampling enabled: standard gating mechanism must be disabled
<b>0</b>	[30:29]	r	<b>Reserved, write 0, read as 0</b>
<b>TMWC</b>	31	w	<b>Write Control for Timer Mode</b> 0 <sub>B</sub> No write access to timer mode 1 <sub>B</sub> Bitfield TMEN can be written

**Versatile Analog-to-Digital Converter (VADC)**

The Queue Mode Register configures the operating mode of a queued request source.

**GxQMR0 (x = 0 - 1)**

**Queue 0 Mode Register, Group x**

(x \* 0400<sub>H</sub> + 0504<sub>H</sub>)

Reset Value: 0000 0000<sub>H</sub>

31	30	29	28	27	26	25	24	23	22	21	20	19	18	17	16
0	0	0	0	0	0	0	0	0	0	0	0	0	0	0	RPT DIS
r	r	r	r	r	r	r	r	r	r	r	r	r	r	r	rw
15	14	13	12	11	10	9	8	7	6	5	4	3	2	1	0
0	0	0	0	CEV	FLU SH	TR EV	CLR V	0	0	0	0	0	0	EN TR	ENGT
r	r	r	r	w	w	w	w	r	r	r	r	r	r	rw	rw

Field	Bits	Type	Description
<b>ENGT</b>	[1:0]	rw	<p><b>Enable Gate</b></p> <p>Selects the gating functionality for source 0/2.</p> <p>00<sub>B</sub> No conversion requests are issued</p> <p>01<sub>B</sub> Conversion requests are issued if a valid conversion request is pending in the queue 0 register or in the backup register</p> <p>10<sub>B</sub> Conversion requests are issued if a valid conversion request is pending in the queue 0 register or in the backup register and REQGTx = 1</p> <p>11<sub>B</sub> Conversion requests are issued if a valid conversion request is pending in the queue 0 register or in the backup register and REQGTx = 0</p> <p><i>Note: REQGTx is the selected gating signal.</i></p>
<b>ENTR</b>	2	rw	<p><b>Enable External Trigger</b></p> <p>0<sub>B</sub> External trigger disabled</p> <p>1<sub>B</sub> The selected edge at the selected trigger input signal REQTR generates the trigger event</p>
<b>0</b>	[7:3]	r	<b>Reserved, write 0, read as 0</b>

**Versatile Analog-to-Digital Converter (VADC)**

Field	Bits	Type	Description
<b>CLRV</b>	8	w	<b>Clear Valid Bit</b> $0_B$ No action $1_B$ The next pending valid queue entry in the sequence and the event flag EV are cleared. If there is a valid entry in the queue backup register (QBUR.V = 1), this entry is cleared, otherwise the entry in queue register 0 is cleared.
<b>TREV</b>	9	w	<b>Trigger Event</b> $0_B$ No action $1_B$ Generate a trigger event by software
<b>FLUSH</b>	10	w	<b>Flush Queue</b> $0_B$ No action $1_B$ Clear all queue entries (including backup stage) and the event flag EV. The queue contains no more valid entry.
<b>CEV</b>	11	w	<b>Clear Event Flag</b> $0_B$ No action $1_B$ Clear bit EV
<b>0</b>	[15:12]	r	<b>Reserved, write 0, read as 0</b>
<b>RPTDIS</b>	16	rw	<b>Repeat Disable</b> $0_B$ A cancelled conversion is repeated $1_B$ A cancelled conversion is discarded
<b>0</b>	[31:17]	r	<b>Reserved, write 0, read as 0</b>

**Versatile Analog-to-Digital Converter (VADC)**

The Queue Status Register indicates the current status of the queued source. The filling level and the empty information refer to the queue intermediate stages (if available) and to the queue register 0. An aborted conversion stored in the backup stage is not indicated by these bits (therefore, see QBURx.V).

**GxQSR0 (x = 0 - 1)**

**Queue 0 Status Register, Group x**

$$(x * 0400_H + 0508_H)$$

**Reset Value: 0000 0020<sub>H</sub>**

31	30	29	28	27	26	25	24	23	22	21	20	19	18	17	16
0	0	0	0	0	0	0	0	0	0	0	0	0	0	0	0
r	r	r	r	r	r	r	r	r	r	r	r	r	r	r	r
15	14	13	12	11	10	9	8	7	6	5	4	3	2	1	0
0	0	0	0	0	0	0	EV	REQ GT	0	EMP TY	0	FILL			
r	r	r	r	r	r	r	rh	rh	r	rh	r	rh			

Field	Bits	Type	Description
<b>FILL</b>	[3:0]	rh	<p><b>Filling Level for Queue 2</b></p> <p>Indicates the number of valid queue entries. It is incremented each time a new entry is written to QINRx or by an enabled refill mechanism. It is decremented each time a requested conversion has been started. A new entry is ignored if the filling level has reached its maximum value.</p> <p>0000<sub>B</sub> There is 1 ( if EMPTY = 0) or no (if EMPTY = 1) valid entry in the queue            0001<sub>B</sub> There are 2 valid entries in the queue            0010<sub>B</sub> There are 3 valid entries in the queue            ...            0111<sub>B</sub> There are 8 valid entries in the queue            others: Reserved</p>
<b>0</b>	4	r	<b>Reserved, write 0, read as 0</b>
<b>EMPTY</b>	5	rh	<p><b>Queue Empty</b></p> <p>0<sub>B</sub> There are valid entries in the queue (see FILL)            1<sub>B</sub> No valid entries (queue is empty)</p>
<b>0</b>	6	r	<b>Reserved, write 0, read as 0</b>

**Versatile Analog-to-Digital Converter (VADC)**

<b>Field</b>	<b>Bits</b>	<b>Type</b>	<b>Description</b>
<b>REQGT</b>	7	rh	<b>Request Gate Level</b> Monitors the level at the selected REQGT input. 0 <sub>B</sub> The gate input is low 1 <sub>B</sub> The gate input is high
<b>EV</b>	8	rh	<b>Event Detected</b> Indicates that an event has been detected while at least one valid entry has been in the queue (queue register 0 or backup stage). Once set, this bit is cleared automatically when the requested conversion is started. 0 <sub>B</sub> No trigger event 1 <sub>B</sub> A trigger event has been detected
<b>0</b>	[31:9]	r	<b>Reserved, write 0, read as 0</b>

**Versatile Analog-to-Digital Converter (VADC)**

The Queue Input Register is the entry point for conversion requests of a queued request source.

**GxQINR0 (x = 0 - 1)**

**Queue 0 Input Register, Group x**

$$(x * 0400_H + 0510_H)$$

**Reset Value: 0000 0000<sub>H</sub>**

31	30	29	28	27	26	25	24	23	22	21	20	19	18	17	16
0	0	0	0	0	0	0	0	0	0	0	0	0	0	0	0
r	r	r	r	r	r	r	r	r	r	r	r	r	r	r	r
15	14	13	12	11	10	9	8	7	6	5	4	3	2	1	0
0	0	0	0	0	0	0	0	EX TR	EN SI	RF	REQCHNR				
r	r	r	r	r	r	r	r	w	w	w	w				

Field	Bits	Type	Description
<b>REQCHNR</b>	[4:0]	w	<b>Request Channel Number</b> Defines the channel number to be converted
<b>RF</b>	5	w	<b>Refill</b> 0 <sub>B</sub> No refill: this queue entry is converted once and then invalidated 1 <sub>B</sub> Automatic refill: this queue entry is automatically reloaded into QINRx when the related conversion is started
<b>ENSI</b>	6	w	<b>Enable Source Interrupt</b> 0 <sub>B</sub> No request source interrupt 1 <sub>B</sub> A request source event interrupt is generated upon a request source event (related conversion is finished)
<b>EXTR</b>	7	w	<b>External Trigger</b> Enables the external trigger functionality. 0 <sub>B</sub> A valid queue entry immediately leads to a conversion request. 1 <sub>B</sub> A valid queue entry waits for a trigger event to occur before issuing a conversion request.
<b>0</b>	[31:8]	r	<b>Reserved, write 0, read as 0</b>

---

**Versatile Analog-to-Digital Converter (VADC)**

*Note: Registers QINRx share addresses with registers QBURx.  
Write operations target the control bits in register QINRx. Read operations return  
the status bits from register QBURx.*

**Versatile Analog-to-Digital Converter (VADC)**

The queue registers 0 monitor the status of the pending request (queue stage 0).

**GxQ0R0 (x = 0 - 1)**

**Queue 0 Register 0, Group x (x \* 0400<sub>H</sub> + 050C<sub>H</sub>)**      **Reset Value: 0000 0000<sub>H</sub>**

31	30	29	28	27	26	25	24	23	22	21	20	19	18	17	16
0	0	0	0	0	0	0	0	0	0	0	0	0	0	0	0
r	r	r	r	r	r	r	r	r	r	r	r	r	r	r	r
15	14	13	12	11	10	9	8	7	6	5	4	3	2	1	0
0	0	0	0	0	0	0	V	EX TR	EN SI	RF	REQCHNR				
r	r	r	r	r	r	r	rh	rh	rh	rh	rh				

Field	Bits	Type	Description
<b>REQCHNR</b>	[4:0]	rh	<b>Request Channel Number</b> Stores the channel number to be converted.
<b>RF</b>	5	rh	<b>Refill</b> Selects the handling of handled requests. 0 <sub>B</sub> The request is discarded after the conversion start. 1 <sub>B</sub> The request is automatically refilled into the queue after the conversion start.
<b>ENSI</b>	6	rh	<b>Enable Source Interrupt</b> 0 <sub>B</sub> No request source interrupt 1 <sub>B</sub> A request source event interrupt is generated upon a request source event (related conversion is finished)
<b>EXTR</b>	7	rh	<b>External Trigger</b> Enables external trigger events. 0 <sub>B</sub> A valid queue entry immediately leads to a conversion request 1 <sub>B</sub> The request handler waits for a trigger event
<b>V</b>	8	rh	<b>Request Channel Number Valid</b> Indicates a valid queue entry in queue register 0. 0 <sub>B</sub> No valid queue entry 1 <sub>B</sub> The queue entry is valid and leads to a conversion request



---

**Versatile Analog-to-Digital Converter (VADC)**

<b>Field</b>	<b>Bits</b>	<b>Type</b>	<b>Description</b>
<b>0</b>	[31:9]	r	<b>Reserved, write 0, read as 0</b>

**Versatile Analog-to-Digital Converter (VADC)**

The Queue Backup Registers monitor the status of an aborted queued request.

**GxQBUR0 (x = 0 - 1)**

**Queue 0 Backup Register, Group x**

$$(x * 0400_H + 0510_H)$$

**Reset Value: 0000 0000<sub>H</sub>**

31	30	29	28	27	26	25	24	23	22	21	20	19	18	17	16
0	0	0	0	0	0	0	0	0	0	0	0	0	0	0	0
r	r	r	r	r	r	r	r	r	r	r	r	r	r	r	r
15	14	13	12	11	10	9	8	7	6	5	4	3	2	1	0
0	0	0	0	0	0	0	V	EXT R	EN SI	RF	REQCHNR				
r	r	r	r	r	r	r	rh	rh	rh	rh	rh				

Field	Bits	Type	Description
<b>REQCHNR</b>	[4:0]	rh	<b>Request Channel Number</b> The channel number of the aborted conversion that has been requested by this request source
<b>RF</b>	5	rh	<b>Refill</b> The refill control bit of the aborted conversion
<b>ENSI</b>	6	rh	<b>Enable Source Interrupt</b> The enable source interrupt control bit of the aborted conversion
<b>EXTR</b>	7	rh	<b>External Trigger</b> The external trigger control bit of the aborted conversion
<b>V</b>	8	rh	<b>Request Channel Number Valid</b> Indicates if the entry (REQCHNR, RF, TR, ENSI) in the queue backup register is valid. Bit V is set when a running conversion (that has been requested by this request source) is aborted, it is cleared when the aborted conversion is restarted. 0 <sub>B</sub> Backup register not valid 1 <sub>B</sub> Backup register contains a valid entry. This will be requested before a valid entry in queue register 0 (stage 0) will be requested.
<b>0</b>	[31:9]	r	<b>Reserved, write 0, read as 0</b>

---

**Versatile Analog-to-Digital Converter (VADC)**

*Note: Registers QBURx share addresses with registers QINRx.  
Read operations return the status bits from register QBURx. Write operations target the control bits in register QINRx.*

**Versatile Analog-to-Digital Converter (VADC)**

**Registers of Group Scan Source**

There is a separate register set for each group scan source. These sources can be operated independently.

The control register of the autoscan source selects the external gate and/or trigger signals.

Write control bits allow separate control of each function with a simple write access.

**GxASCTRL (x = 0 - 1)**

**Autoscan Source Control Register, Group x**

(x \* 0400<sub>H</sub> + 0520<sub>H</sub>)      **Reset Value: 0000 0000<sub>H</sub>**

31	30	29	28	27	26	25	24	23	22	21	20	19	18	17	16
<b>TM WC</b>	<b>0</b>	<b>0</b>	<b>TM EN</b>	<b>0</b>	<b>0</b>	<b>0</b>	<b>0</b>	<b>GT WC</b>	<b>0</b>	<b>0</b>	<b>GT LVL</b>			<b>GT SEL</b>	
w	r	r	rw	r	r	r	r	w	r	r	rh			rw	
15	14	13	12	11	10	9	8	7	6	5	4	3	2	1	0
<b>XT WC</b>	<b>XT MODE</b>	<b>XT LVL</b>			<b>XT SEL</b>			<b>0</b>	<b>0</b>	<b>0</b>	<b>0</b>			<b>SRCRESREG</b>	
w	rw	rh			rw			r	r	r	r			rwr	

Field	Bits	Type	Description
<b>SRCRESREG</b>	[3:0]	rw	<b>Source-specific Result Register</b> 0000 <sub>B</sub> Use GxCHCTry.RESREG to select a group result register 0001 <sub>B</sub> Store result in group result register GxRES1 ... 1111 <sub>B</sub> Store result in group result register GxRES15
<b>0</b>	[7:4]	r	<b>Reserved, write 0, read as 0</b>
<b>XTSEL</b>	[11:8]	rw	<b>External Trigger Input Selection</b> The connected trigger input signals are listed in <a href="#">Table 16-15 “Digital Connections in the XMC1200” on Page 16-154</a> <i>Note: XTSEL = 1111<sub>B</sub> uses the selected gate input as trigger source (ENG T must be 0x<sub>B</sub>).</i>
<b>XTLVL</b>	12	rh	<b>External Trigger Level</b> Current level of the selected trigger input

**Versatile Analog-to-Digital Converter (VADC)**

Field	Bits	Type	Description
<b>XTMODE</b>	[14:13]	rw	<b>Trigger Operating Mode</b> 00 <sub>B</sub> No external trigger 01 <sub>B</sub> Trigger event upon a falling edge 10 <sub>B</sub> Trigger event upon a rising edge 11 <sub>B</sub> Trigger event upon any edge
<b>XTWC</b>	15	w	<b>Write Control for Trigger Configuration</b> 0 <sub>B</sub> No write access to trigger configuration 1 <sub>B</sub> Bitfields XTMODE and XTSEL can be written
<b>GTSEL</b>	[19:16]	rw	<b>Gate Input Selection</b> The connected gate input signals are listed in <a href="#">Table 16-15 “Digital Connections in the XMC1200” on Page 16-154</a>
<b>GTLVL</b>	20	rh	<b>Gate Input Level</b> Current level of the selected gate input
<b>0</b>	[22:21]	r	<b>Reserved, write 0, read as 0</b>
<b>GTWC</b>	23	w	<b>Write Control for Gate Configuration</b> 0 <sub>B</sub> No write access to gate configuration 1 <sub>B</sub> Bitfield GTSEL can be written
<b>0</b>	[27:24]	r	<b>Reserved, write 0, read as 0</b>
<b>TMEN</b>	28	rw	<b>Timer Mode Enable</b> 0 <sub>B</sub> No timer mode: standard gating mechanism can be used 1 <sub>B</sub> Timer mode for equidistant sampling enabled: standard gating mechanism must be disabled
<b>0</b>	[30:29]	r	<b>Reserved, write 0, read as 0</b>
<b>TMWC</b>	31	w	<b>Write Control for Timer Mode</b> 0 <sub>B</sub> No write access to timer mode 1 <sub>B</sub> Bitfield TMEN can be written

**Versatile Analog-to-Digital Converter (VADC)**

The Conversion Request Mode Register configures the operating mode of the channel scan request source.

**GxASMR (x = 0 - 1)**

**Autoscan Source Mode Register, Group x**

(x \* 0400<sub>H</sub> + 0524<sub>H</sub>)

Reset Value: 0000 0000<sub>H</sub>

31	30	29	28	27	26	25	24	23	22	21	20	19	18	17	16
0	0	0	0	0	0	0	0	0	0	0	0	0	0	0	RPT DIS
r	r	r	r	r	r	r	r	r	r	r	r	r	r	r	rw
15	14	13	12	11	10	9	8	7	6	5	4	3	2	1	0
0	0	0	0	0	0	LD EV	CLR PND	REQ GT	0	LDM	SCAN	EN SI	EN TR		
r	r	r	r	r	r	w	w	rh	r	rw	rw	rw	rw		rw

Field	Bits	Type	Description
<b>ENGT</b>	[1:0]	rw	<p><b>Enable Gate</b></p> <p>Selects the gating functionality for source 1.</p> <p>00<sub>B</sub> No conversion requests are issued</p> <p>01<sub>B</sub> Conversion requests are issued if at least one pending bit is set</p> <p>10<sub>B</sub> Conversion requests are issued if at least one pending bit is set and REQGTx = 1.</p> <p>11<sub>B</sub> Conversion requests are issued if at least one pending bit is set and REQGTx = 0.</p> <p><i>Note: REQGTx is the selected gating signal.</i></p>
<b>ENTR</b>	2	rw	<p><b>Enable External Trigger</b></p> <p>0<sub>B</sub> External trigger disabled</p> <p>1<sub>B</sub> The selected edge at the selected trigger input signal REQTR generates the load event</p>
<b>ENSI</b>	3	rw	<p><b>Enable Source Interrupt</b></p> <p>0<sub>B</sub> No request source interrupt</p> <p>1<sub>B</sub> A request source interrupt is generated upon a request source event (last pending conversion is finished)</p>

**Versatile Analog-to-Digital Converter (VADC)**

Field	Bits	Type	Description
<b>SCAN</b>	4	rw	<b>Autoscan Enable</b> 0 <sub>B</sub> No autoscan 1 <sub>B</sub> Autoscan functionality enabled: a request source event automatically generates a load event
<b>LDM</b>	5	rw	<b>Autoscan Source Load Event Mode</b> 0 <sub>B</sub> Overwrite mode: Copy all bits from the select registers to the pending registers upon a load event 1 <sub>B</sub> Combine mode: Set all pending bits that are set in the select registers upon a load event (logic OR)
<b>0</b>	6	r	<b>Reserved, write 0, read as 0</b>
<b>REQGT</b>	7	rh	<b>Request Gate Level</b> Monitors the level at the selected REQGT input. 0 <sub>B</sub> The gate input is low 1 <sub>B</sub> The gate input is high
<b>CLRPND</b>	8	w	<b>Clear Pending Bits</b> 0 <sub>B</sub> No action 1 <sub>B</sub> The bits in register GxASPNDx are cleared
<b>LDEV</b>	9	w	<b>Generate Load Event</b> 0 <sub>B</sub> No action 1 <sub>B</sub> A load event is generated
<b>0</b>	[15:10]	r	<b>Reserved, write 0, read as 0</b>
<b>RPTDIS</b>	16	rw	<b>Repeat Disable</b> 0 <sub>B</sub> A cancelled conversion is repeated 1 <sub>B</sub> A cancelled conversion is discarded
<b>0</b>	[31:17]	r	<b>Reserved, write 0, read as 0</b>

**Versatile Analog-to-Digital Converter (VADC)**

The Channel Select Register selects the channels to be converted by the group scan request source. Its bits are used to update the pending register, when a load event occurs.

The number of valid channel bits depends on the channels available in the respective product type (please refer to **“Product-Specific Configuration” on Page 16-151**).

**GxASSEL (x = 0 - 1)**

**Autoscan Source Channel Select Register, Group x**

$(x * 0400_H + 0528_H)$

**Reset Value: 0000 0000<sub>H</sub>**

31	30	29	28	27	26	25	24	23	22	21	20	19	18	17	16
0	0	0	0	0	0	0	0	0	0	0	0	0	0	0	0
r	r	r	r	r	r	r	r	r	r	r	r	r	r	r	r
15	14	13	12	11	10	9	8	7	6	5	4	3	2	1	0
0	0	0	0	0	0	0	0	CH SEL 7	CH SEL 6	CH SEL 5	CH SEL 4	CH SEL 3	CH SEL 2	CH SEL 1	CH SEL 0
r	r	r	r	r	r	r	r	rwh	rwh	rwh	rwh	rwh	rwh	rwh	rwh

Field	Bits	Type	Description
<b>CHSELY</b> (y = 0 - 7)	y	rwh	<b>Channel Selection</b> Each bit (when set) enables the corresponding input channel of the respective group to take part in the scan sequence. 0 <sub>B</sub> Ignore this channel 1 <sub>B</sub> This channel is part of the scan sequence
<b>0</b>	[31:8]	r	<b>Reserved, write 0, read as 0</b>

*Note: Register GxASSEL is also updated when writing a pattern to register GxASPND.*

The Channel Pending Register indicates the channels to be converted in the current conversion sequence. They are updated from the select register, when a load event occurs.



**Versatile Analog-to-Digital Converter (VADC)**

**GxASPND (x = 0 - 1)**

**Autoscan Source Pending Register, Group x**

$$(x * 0400_H + 052C_H)$$

**Reset Value: 0000 0000<sub>H</sub>**

31	30	29	28	27	26	25	24	23	22	21	20	19	18	17	16
0	0	0	0	0	0	0	0	0	0	0	0	0	0	0	0
r	r	r	r	r	r	r	r	r	r	r	r	r	r	r	r
15	14	13	12	11	10	9	8	7	6	5	4	3	2	1	0
0	0	0	0	0	0	0	0	CH PND 7	CH PND 6	CH PND 5	CH PND 4	CH PND 3	CH PND 2	CH PND 1	CH PND 0
r	r	r	r	r	r	r	r	rwh	rwh	rwh	rwh	rwh	rwh	rwh	rwh

Field	Bits	Type	Description
<b>CHPNDy</b> <b>(y = 0 - 7)</b>	y	rwh	<b>Channels Pending</b> Each bit (when set) request the conversion of the corresponding input channel of the respective group. 0 <sub>B</sub> Ignore this channel 1 <sub>B</sub> Request conversion of this channel
<b>0</b>	[31:8]	r	<b>Reserved, write 0, read as 0</b>

*Note: Writing to register GxASPND automatically updates register GxASSEL.*

**Versatile Analog-to-Digital Converter (VADC)**

**Registers of Background Scan Source**

There is a single register set for the background scan source. This source is common for the complete VADC.

The control register of the background request source selects the external gate and/or trigger signals.

Write control bits allow separate control of each function with a simple write access.

**BRSCTRL**

**Background Request Source Control Register**

(0200<sub>H</sub>)

Reset Value: 0000 0000<sub>H</sub>

31	30	29	28	27	26	25	24	23	22	21	20	19	18	17	16
0	0	0	0	0	0	0	0	GT WC	0	0	GT LVL			GT SEL	
r	r	r	r	r	r	r	r	w	r	r	rh			rw	
15	14	13	12	11	10	9	8	7	6	5	4	3	2	1	0
XT WC	XT MODE	XT LVL			XT SEL			0	0	0	0			SRCRESREG	
w	rw	rh			rw			r	r	r	r				rw

Field	Bits	Type	Description
<b>SRCRESREG</b>	[3:0]	rw	<b>Source-specific Result Register</b> 0000 <sub>B</sub> Use GxCHCTry.RESREG to select a group result register 0001 <sub>B</sub> Store result in group result register GxRES1 ... 1111 <sub>B</sub> Store result in group result register GxRES15
<b>0</b>	[7:4]	r	<b>Reserved, write 0, read as 0</b>
<b>XTSEL</b>	[11:8]	rw	<b>External Trigger Input Selection</b> The connected trigger input signals are listed in <a href="#">Table 16-15 “Digital Connections in the XMC1200” on Page 16-154</a> <i>Note: XTSEL = 1111<sub>B</sub> uses the selected gate input as trigger source (ENGT must be 0X<sub>B</sub>).</i>
<b>XTLVL</b>	12	rh	<b>External Trigger Level</b> Current level of the selected trigger input

**Versatile Analog-to-Digital Converter (VADC)**

<b>Field</b>	<b>Bits</b>	<b>Type</b>	<b>Description</b>
<b>XTMODE</b>	[14:13]	rw	<b>Trigger Operating Mode</b> 00 <sub>B</sub> No external trigger 01 <sub>B</sub> Trigger event upon a falling edge 10 <sub>B</sub> Trigger event upon a rising edge 11 <sub>B</sub> Trigger event upon any edge
<b>XTWC</b>	15	w	<b>Write Control for Trigger Configuration</b> 0 <sub>B</sub> No write access to trigger configuration 1 <sub>B</sub> Bitfields XTMODE and XTSEL can be written
<b>GTSEL</b>	[19:16]	rw	<b>Gate Input Selection</b> The connected gate input signals are listed in <a href="#">Table 16-15 “Digital Connections in the XMC1200” on Page 16-154</a>
<b>GTLVL</b>	20	rh	<b>Gate Input Level</b> Current level of the selected gate input
<b>0</b>	[22:21]	r	<b>Reserved, write 0, read as 0</b>
<b>GTWC</b>	23	w	<b>Write Control for Gate Configuration</b> 0 <sub>B</sub> No write access to gate configuration 1 <sub>B</sub> Bitfield GTSEL can be written
<b>0</b>	[31:24]	r	<b>Reserved, write 0, read as 0</b>

**Versatile Analog-to-Digital Converter (VADC)**

The Conversion Request Mode Register configures the operating mode of the background request source.

**BRSMR**

**Background Request Source Mode Register**  
**(0204<sub>H</sub>)**

**Reset Value: 0000 0000<sub>H</sub>**

31	30	29	28	27	26	25	24	23	22	21	20	19	18	17	16
0	0	0	0	0	0	0	0	0	0	0	0	0	0	0	RPT DIS
r	r	r	r	r	r	r	r	r	r	r	r	r	r	r	rw
15	14	13	12	11	10	9	8	7	6	5	4	3	2	1	0
0	0	0	0	0	0	LD EV	CLR PND	REQ GT	0	LDM	SCAN	EN SI	EN TR	ENGT	
r	r	r	r	r	r	w	w	rh	r	rw	rw	rw	rw	rw	rw

Field	Bits	Type	Description
<b>ENGT</b>	[1:0]	rw	<p><b>Enable Gate</b></p> <p>Selects the gating functionality for source 1.</p> <p>00<sub>B</sub> No conversion requests are issued</p> <p>01<sub>B</sub> Conversion requests are issued if at least one pending bit is set</p> <p>10<sub>B</sub> Conversion requests are issued if at least one pending bit is set and REQGTx = 1.</p> <p>11<sub>B</sub> Conversion requests are issued if at least one pending bit is set and REQGTx = 0.</p> <p><i>Note: REQGTx is the selected gating signal.</i></p>
<b>ENTR</b>	2	rw	<p><b>Enable External Trigger</b></p> <p>0<sub>B</sub> External trigger disabled</p> <p>1<sub>B</sub> The selected edge at the selected trigger input signal REQTR generates the load event</p>
<b>ENSI</b>	3	rw	<p><b>Enable Source Interrupt</b></p> <p>0<sub>B</sub> No request source interrupt</p> <p>1<sub>B</sub> A request source interrupt is generated upon a request source event (last pending conversion is finished)</p>

**Versatile Analog-to-Digital Converter (VADC)**

Field	Bits	Type	Description
<b>SCAN</b>	4	rw	<b>Autoscan Enable</b> $0_B$ No autoscan $1_B$ Autoscan functionality enabled: a request source event automatically generates a load event
<b>LDM</b>	5	rw	<b>Autoscan Source Load Event Mode</b> $0_B$ Overwrite mode: Copy all bits from the select registers to the pending registers upon a load event $1_B$ Combine mode: Set all pending bits that are set in the select registers upon a load event (logic OR)
<b>0</b>	6	r	<b>Reserved, write 0, read as 0</b>
<b>REQGT</b>	7	rh	<b>Request Gate Level</b> Monitors the level at the selected REQGT input. $0_B$ The gate input is low $1_B$ The gate input is high
<b>CLRPND</b>	8	w	<b>Clear Pending Bits</b> $0_B$ No action $1_B$ The bits in registers BRSPNDx are cleared
<b>LDEV</b>	9	w	<b>Generate Load Event</b> $0_B$ No action $1_B$ A load event is generated
<b>0</b>	[15:10]	r	<b>Reserved, write 0, read as 0</b>
<b>RPTDIS</b>	16	rw	<b>Repeat Disable</b> $0_B$ A cancelled conversion is repeated $1_B$ A cancelled conversion is discarded
<b>0</b>	[31:17]	r	<b>Reserved, write 0, read as 0</b>

**Versatile Analog-to-Digital Converter (VADC)**

The Channel Select Registers select the channels to be converted by the background request source (channel scan source). Its bits are used to update the pending registers, when a load event occurs.

The number of valid channel bits depends on the channels available in the respective product type (please refer to **“Product-Specific Configuration” on Page 16-151**).

*Note: Priority channels selected in registers **GxCHASS (x = 0 - 1)** will not be converted.*

**BRSELx (x = 0 - 1)**

**Background Request Source Channel Select Register, Group x**  
**(0180<sub>H</sub> + x \* 0004<sub>H</sub>)**      **Reset Value: 0000 0000<sub>H</sub>**

31	30	29	28	27	26	25	24	23	22	21	20	19	18	17	16
0	0	0	0	0	0	0	0	0	0	0	0	0	0	0	0
r	r	r	r	r	r	r	r	r	r	r	r	r	r	r	r
15	14	13	12	11	10	9	8	7	6	5	4	3	2	1	0
0	0	0	0	0	0	0	0	CH SEL G7	CH SEL G6	CH SEL G5	CH SEL G4	CH SEL G3	CH SEL G2	CH SEL G1	CH SEL G0
r	r	r	r	r	r	r	r	rwh	rwh	rwh	rwh	rwh	rwh	rwh	rwh

Field	Bits	Type	Description
<b>CHSELGy</b> <b>(y = 0 - 7)</b>	y	rwh	<b>Channel Selection Group x</b> Each bit (when set) enables the corresponding input channel of the respective group to take part in the background scan sequence. 0 <sub>B</sub> Ignore this channel 1 <sub>B</sub> This channel is part of the scan sequence
<b>0</b>	[31:8]	r	<b>Reserved, write 0, read as 0</b>

**Versatile Analog-to-Digital Converter (VADC)**

The Channel Pending Registers indicate the channels to be converted in the current conversion sequence. They are updated from the select registers, when a load event occurs.

**BRSPNDx (x = 0 - 1)**

**Background Request Source Pending Register, Group x**

**(01C0<sub>H</sub> + x \* 0004<sub>H</sub>)**

**Reset Value: 0000 0000<sub>H</sub>**

31	30	29	28	27	26	25	24	23	22	21	20	19	18	17	16
0	0	0	0	0	0	0	0	0	0	0	0	0	0	0	0
r	r	r	r	r	r	r	r	r	r	r	r	r	r	r	r
15	14	13	12	11	10	9	8	7	6	5	4	3	2	1	0
0	0	0	0	0	0	0	0	CH PND G7	CH PND G6	CH PND G5	CH PND G4	CH PND G3	CH PND G2	CH PND G1	CH PND G0
r	r	r	r	r	r	r	r	rwh	rwh	rwh	rwh	rwh	rwh	rwh	rwh

Field	Bits	Type	Description
<b>CHPNDGy</b> <b>(y = 0 - 7)</b>	y	rwh	<b>Channels Pending Group x</b> Each bit (when set) request the conversion of the corresponding input channel of the respective group. 0 <sub>B</sub> Ignore this channel 1 <sub>B</sub> Request conversion of this channel
<b>0</b>	[31:8]	r	<b>Reserved, write 0, read as 0</b>

*Note: Writing to any of registers BRSPNDx automatically updates the corresponding register BRSELx and generates a load event that copies all bits from all registers BRSELx to BRSPNDx.*

*Use this shortcut only when writing the last word of the request pattern.*

**Versatile Analog-to-Digital Converter (VADC)**

### 16.16.5 Channel Control Registers

**G0CHCTry (y = 0 - 7)**

**Group 0, Channel y Ctrl. Reg. (0600<sub>H</sub> + y \* 0004<sub>H</sub>)      Reset Value: 0000 0000<sub>H</sub>**

**G1CHCTry (y = 0 - 7)**

**Group 1, Channel y Ctrl. Reg. (0A00<sub>H</sub> + y \* 0004<sub>H</sub>)      Reset Value: 0000 0000<sub>H</sub>**

31	30	29	28	27	26	25	24	23	22	21	20	19	18	17	16
<b>0</b>	<b>BWD EN</b>	<b>BWD CH</b>	<b>0</b>	<b>0</b>	<b>0</b>	<b>0</b>	<b>0</b>	<b>0</b>	<b>0</b>	<b>RES POS</b>	<b>RES TBS</b>	<b>RESREG</b>			
r	rw	rw	r	r	r	r	r	r	r	rw	rw	rw			
15	14	13	12	11	10	9	8	7	6	5	4	3	2	1	0
<b>BNDSELX</b>			<b>REF SEL</b>	<b>SY NC</b>	<b>CHEV MODE</b>	<b>BNDSELU</b>		<b>BNDSELL</b>		<b>0</b>	<b>0</b>	<b>ICLSEL</b>			
rw			rw	rw	rw	rw		rw		r	r	rw			

Field	Bits	Type	Description
<b>ICLSEL</b>	[1:0]	rw	<b>Input Class Select</b> 00 <sub>B</sub> Use group-specific class 0 01 <sub>B</sub> Use group-specific class 1 10 <sub>B</sub> Use global class 0 11 <sub>B</sub> Use global class 1
<b>0</b>	[3:2]	r	<b>Reserved, write 0, read as 0</b>
<b>BNDSELL</b>	[5:4]	rw	<b>Lower Boundary Select<sup>1)</sup></b> 00 <sub>B</sub> Use group-specific boundary 0 01 <sub>B</sub> Use group-specific boundary 1 10 <sub>B</sub> Use global boundary 0 11 <sub>B</sub> Use global boundary 1
<b>BNDSELU</b>	[7:6]	rw	<b>Upper Boundary Select<sup>1)</sup></b> 00 <sub>B</sub> Use group-specific boundary 0 01 <sub>B</sub> Use group-specific boundary 1 10 <sub>B</sub> Use global boundary 0 11 <sub>B</sub> Use global boundary 1



**Versatile Analog-to-Digital Converter (VADC)**

Field	Bits	Type	Description
<b>CHEVMODE</b>	[9:8]	rw	<b>Channel Event Mode</b> Generate a channel event either in normal compare mode (NCM) with limit checking <sup>2)</sup> or in Fast Compare Mode (FCM) <sup>3)</sup> 00 <sub>B</sub> Never 01 <sub>B</sub> NCM: If result is inside the boundary band FCM: If result becomes high (above cmp. val.) 10 <sub>B</sub> NCM: If result is outside the boundary band FCM: If result becomes low (below cmp. val.) 11 <sub>B</sub> NCM: Always (ignore band) FCM: If result switches to either level
<b>SYNC</b>	10	rw	<b>Synchronization Request</b> 0 <sub>B</sub> No synchroniz. request, standalone operation 1 <sub>B</sub> Request a synchronized conversion of this channel (only taken into account for a master)
<b>REFSEL</b>	11	rw	<b>Reference Input Selection</b> Defines the reference voltage input to be used for conversions on this channel. 0 <sub>B</sub> Standard reference Ground $V_{SSC}$ 1 <sub>B</sub> Alternate reference Ground from CH0 <sup>4)</sup>
<b>BNDSELX</b>	[15:12]	rw	<b>Boundary Extension<sup>1)</sup></b> 0000 <sub>B</sub> Standard mode: select boundaries via BNDSELU/BNDSSELL 0001 <sub>B</sub> Use result reg. GxRES1 as upper boundary ... 1111 <sub>B</sub> Use result reg. GxRES15 as upper boundary
<b>RESREG</b>	[19:16]	rw	<b>Result Register</b> 0000 <sub>B</sub> Store result in group result register GxRES0 ... 1111 <sub>B</sub> Store result in group result register GxRES15
<b>RESTBS</b>	20	rw	<b>Result Target for Background Source</b> 0 <sub>B</sub> Store results in the selected group result register register 1 <sub>B</sub> Store results in the global result register
<b>RESPOS</b>	21	rw	<b>Result Position</b> 0 <sub>B</sub> Store results left-aligned 1 <sub>B</sub> Store results right-aligned
<b>0</b>	[27:22]	r	<b>Reserved, write 0, read as 0</b>

**Versatile Analog-to-Digital Converter (VADC)**

Field	Bits	Type	Description
<b>BWDCH</b>	[29:28]	rw	<b>Broken Wire Detection Channel</b> 00 <sub>B</sub> Select $V_{AREF}$ 01 <sub>B</sub> Select $V_{AGND}$ 10 <sub>B</sub> Reserved 11 <sub>B</sub> Reserved
<b>BWDEN</b>	30	rw	<b>Broken Wire Detection Enable</b> 0 <sub>B</sub> Normal operation 1 <sub>B</sub> Additional preparation phase is enabled
<b>0</b>	31	r	<b>Reserved, write 0, read as 0</b>

- 1) While BNDSELX  $\neq$  0000<sub>B</sub>, bitfields BNDSELU and BNDSELL are concatenated and select the corresponding result register as lower boundary.
- 2) The boundary band is defined as the area where the result is less than or equal to the selected upper boundary and greater than or equal to the selected lower boundary, see [Section 16.8.4](#).
- 3) The result is bit FCR in the selected result register.
- 4) Some channels cannot select an alternate reference.

**GxICLASS0 (x = 0 - 1)**

**Input Class Register 0, Group x**

( $x * 0400_H + 04A0_H$ )      **Reset Value: 0000 0000<sub>H</sub>**

**GxICLASS1 (x = 0 - 1)**

**Input Class Register 1, Group x**

( $x * 0400_H + 04A4_H$ )      **Reset Value: 0000 0000<sub>H</sub>**

**GLOBICLASSy (y = 0 - 1)**

**Input Class Register y, Global**

( $00A0_H + y * 0004_H$ )      **Reset Value: 0000 0000<sub>H</sub>**

31	30	29	28	27	26	25	24	23	22	21	20	19	18	17	16
0	0	0	0	0	CME		0	0	0	STCE					
r	r	r	r	r	rw		r	r	r	rw					
15	14	13	12	11	10	9	8	7	6	5	4	3	2	1	0
0	0	0	0	0	CMS		0	0	0	STCS					
r	r	r	r	r	rw		r	r	r	rw					

**Versatile Analog-to-Digital Converter (VADC)**

Field	Bits	Type	Description
<b>STCS</b>	[4:0]	rw	<b>Sample Time Control for Standard Conversions</b> Number of additional clock cycles to be added to the minimum sample phase of 2 analog clock cycles: Coding and resulting sample time see <a href="#">Table 16-11</a> . For conversions of external channels, the value from bitfield STCE can be used.
<b>0</b>	[7:5]	r	<b>Reserved, write 0, read as 0</b>
<b>CMS</b>	[10:8]	rw	<b>Conversion Mode for Standard Conversions</b> 000 <sub>B</sub> 12-bit conversion 001 <sub>B</sub> 10-bit conversion 010 <sub>B</sub> 8-bit conversion 011 <sub>B</sub> Reserved 100 <sub>B</sub> Reserved 101 <sub>B</sub> 10-bit fast compare mode 110 <sub>B</sub> Reserved 111 <sub>B</sub> Reserved
<b>0</b>	[15:11]	r	<b>Reserved, write 0, read as 0</b>
<b>STCE</b>	[20:16]	rw	<b>Sample Time Control for EMUX Conversions</b> Number of additional clock cycles to be added to the minimum sample phase of 2 analog clock cycles: Coding and resulting sample time see <a href="#">Table 16-11</a> . For conversions of standard channels, the value from bitfield STCS is used.
<b>0</b>	[23:21]	r	<b>Reserved, write 0, read as 0</b>
<b>CME</b>	[26:24]	rw	<b>Conversion Mode for EMUX Conversions</b> 000 <sub>B</sub> 12-bit conversion 001 <sub>B</sub> 10-bit conversion 010 <sub>B</sub> 8-bit conversion 011 <sub>B</sub> Reserved 100 <sub>B</sub> Reserved 101 <sub>B</sub> 10-bit fast compare mode 110 <sub>B</sub> Reserved 111 <sub>B</sub> Reserved
<b>0</b>	[31:27]	r	<b>Reserved, write 0, read as 0</b>

**Table 16-11 Sample Time Coding**

<b>STCS / STCE</b>	<b>Additional Clock Cycles</b>	<b>Sample Time</b>
0 0000 <sub>B</sub>	0	$2 / f_{\text{ADCI}}$
0 0001 <sub>B</sub>	1	$3 / f_{\text{ADCI}}$
...	...	...
0 1111 <sub>B</sub>	15	$17 / f_{\text{ADCI}}$
1 0000 <sub>B</sub>	16	$18 / f_{\text{ADCI}}$
1 0001 <sub>B</sub>	32	$34 / f_{\text{ADCI}}$
...	...	...
1 1110 <sub>B</sub>	240	$242 / f_{\text{ADCI}}$
1 1111 <sub>B</sub>	256	$258 / f_{\text{ADCI}}$

**Versatile Analog-to-Digital Converter (VADC)**

**16.16.6 Result Registers**

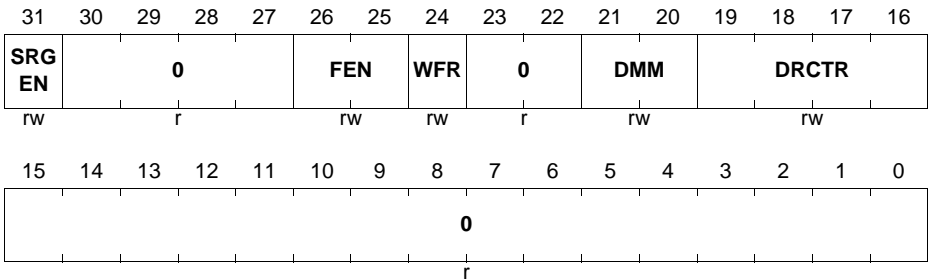
The group result control registers select the behavior of the result registers of a given group.

**G0RCR<sub>y</sub> (y = 0 - 15)**

**Group 0 Result Control Reg. y (0680<sub>H</sub> + y \* 0004<sub>H</sub>)**      **Reset Value: 0000 0000<sub>H</sub>**

**G1RCR<sub>y</sub> (y = 0 - 15)**

**Group 1 Result Control Reg. y (0A80<sub>H</sub> + y \* 0004<sub>H</sub>)**      **Reset Value: 0000 0000<sub>H</sub>**



Field	Bits	Type	Description
<b>0</b>	[15:0]	r	<b>Reserved, write 0, read as 0</b>
<b>DRCTR</b>	[19:16]	rw	<b>Data Reduction Control</b> Defines how result values are stored/accumulated in this register for the final result. The data reduction counter DRC can be loaded from this bitfield. The function of bitfield DRCTR is determined by bitfield DMM.
<b>DMM</b>	[21:20]	rw	<b>Data Modification Mode</b> 00 <sub>B</sub> Standard data reduction (accumulation) 01 <sub>B</sub> Result filtering mode <sup>1)</sup> 10 <sub>B</sub> Difference mode 11 <sub>B</sub> Reserved See <a href="#">“Data Modification” on Page 16-47</a>
<b>0</b>	[23:22]	r	<b>Reserved, write 0, read as 0</b>
<b>WFR</b>	24	rw	<b>Wait-for-Read Mode Enable</b> 0 <sub>B</sub> Overwrite mode 1 <sub>B</sub> Wait-for-read mode enabled for this register

**Versatile Analog-to-Digital Converter (VADC)**

<b>Field</b>	<b>Bits</b>	<b>Type</b>	<b>Description</b>
<b>FEN</b>	[26:25]	rw	<b>FIFO Mode Enable</b> 00 <sub>B</sub> Separate result register 01 <sub>B</sub> Part of a FIFO structure: copy each new valid result 10 <sub>B</sub> Maximum mode: copy new result if bigger 11 <sub>B</sub> Minimum mode: copy new result if smaller
<b>0</b>	[30:27]	r	<b>Reserved, write 0, read as 0</b>
<b>SRGEN</b>	31	rw	<b>Service Request Generation Enable</b> 0 <sub>B</sub> No service request 1 <sub>B</sub> Service request after a result event

1) The filter registers are cleared while bitfield DMM ≠ 01<sub>B</sub>.

**Versatile Analog-to-Digital Converter (VADC)**

The group result registers provide a selectable storage location for all channels of a given group.

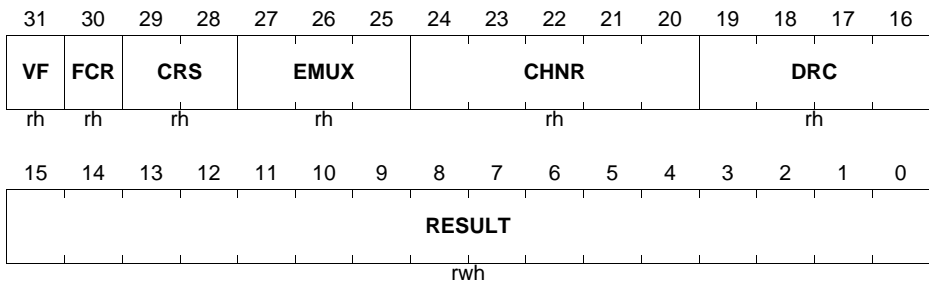
*Note: The preset value used in fast compare mode is written to the respective result register. The debug result registers are not writable.*

**G0RESy (y = 0 - 15)**

**Group 0 Result Register y**      **(0700<sub>H</sub> + y \* 0004<sub>H</sub>)**      **Reset Value: 0000 0000<sub>H</sub>**

**G1RESy (y = 0 - 15)**

**Group 1 Result Register y**      **(0B00<sub>H</sub> + y \* 0004<sub>H</sub>)**      **Reset Value: 0000 0000<sub>H</sub>**



Field	Bits	Type	Description
<b>RESULT</b>	[15:0]	rwh	<b>Result of Most Recent Conversion</b> The position of the result bits within this bitfield depends on the configured operating mode. Please, refer to <a href="#">Section 16.11.2</a> .
<b>DRC</b>	[19:16]	rh	<b>Data Reduction Counter</b> Indicates the number of values still to be accumulated for the final result. The final result is available and valid flag VF is set when bitfield DRC becomes zero (by decrementing or by reload). See <a href="#">“Data Modification” on Page 16-47</a>
<b>CHNR</b>	[24:20]	rh	<b>Channel Number</b> Indicates the channel number corresponding to the value in bitfield RESULT.
<b>EMUX</b>	[27:25]	rh	<b>External Multiplexer Setting</b> Indicates the setting of the external multiplexer, corresponding to the value in bitfield RESULT. <i>Note: Available in GxRES0 only. Use GxRES0 if EMUX information is required.</i>

**Versatile Analog-to-Digital Converter (VADC)**

Field	Bits	Type	Description
<b>CRS</b>	[29:28]	rh	<b>Converted Request Source</b> Indicates the request source that as requested the conversion to which the result value in bitfield RESULT belongs. 00 <sub>B</sub> Request source 0 01 <sub>B</sub> Request source 1 10 <sub>B</sub> Request source 2 11 <sub>B</sub> Reserved
<b>FCR</b>	30	rh	<b>Fast Compare Result</b> Indicates the result of an operation in Fast Compare Mode. 0 <sub>B</sub> Signal level was below compare value 1 <sub>B</sub> Signal level was above compare value
<b>VF</b>	31	rh	<b>Valid Flag</b> Indicates a new result in bitfield RESULT or bit FCR. 0 <sub>B</sub> No new result available 1 <sub>B</sub> Bitfield RESULT has been updated with new result value and has not yet been read, or bit FCR has been updated

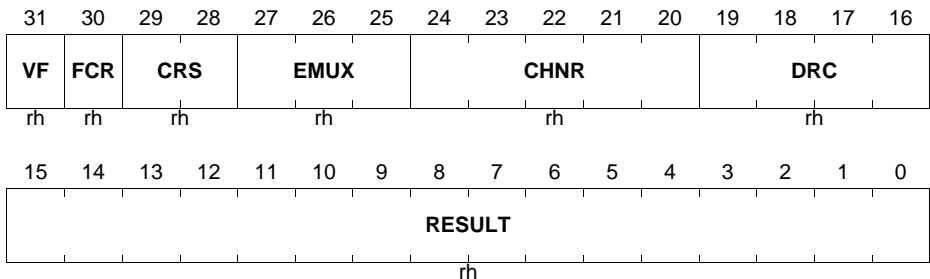
The debug view of the group result registers provides access to all result registers of a given group, however, without clearing the valid flag.

**G0RESDy (y = 0 - 15)**

**Group 0 Result Reg. y, Debug (0780<sub>H</sub> + y \* 0004<sub>H</sub>)**      **Reset Value: 0000 0000<sub>H</sub>**

**G1RESDy (y = 0 - 15)**

**Group 1 Result Reg. y, Debug (0B80<sub>H</sub> + y \* 0004<sub>H</sub>)**      **Reset Value: 0000 0000<sub>H</sub>**





**Versatile Analog-to-Digital Converter (VADC)**

<b>Field</b>	<b>Bits</b>	<b>Type</b>	<b>Description</b>
<b>RESULT</b>	[15:0]	rh	<b>Result of Most Recent Conversion</b> The position of the result bits within this bitfield depends on the configured operating mode. Please, refer to <a href="#">Section 16.11.2</a> .
<b>DRC</b>	[19:16]	rh	<b>Data Reduction Counter</b> Indicates the number of values still to be accumulated for the final result. The final result is available and valid flag VF is set when bitfield DRC becomes zero (by decrementing or by reload). See <a href="#">“Data Modification” on Page 16-47</a>
<b>CHNR</b>	[24:20]	rh	<b>Channel Number</b> Indicates the channel number corresponding to the value in bitfield RESULT.
<b>EMUX</b>	[27:25]	rh	<b>External Multiplexer Setting</b> Indicates the setting of the external multiplexer, corresponding to the value in bitfield RESULT. <i>Note: Available in GxRES0 only. Use GxRES0 if EMUX information is required.</i>
<b>CRS</b>	[29:28]	rh	<b>Converted Request Source</b> Indicates the request source that as requested the conversion to which the result value in bitfield RESULT belongs. 00 <sub>B</sub> Request source 0 01 <sub>B</sub> Request source 1 10 <sub>B</sub> Request source 2 11 <sub>B</sub> Reserved
<b>FCR</b>	30	rh	<b>Fast Compare Result</b> Indicates the result of an operation in Fast Compare Mode. 0 <sub>B</sub> Signal level was below compare value 1 <sub>B</sub> Signal level was above compare value

**Versatile Analog-to-Digital Converter (VADC)**

Field	Bits	Type	Description
VF	31	rh	<b>Valid Flag</b> Indicates a new result in bitfield RESULT or bit FCR. 0 <sub>B</sub> No new result available 1 <sub>B</sub> Bitfield RESULT has been updated with new result value and has not yet been read, or bit FCR has been updated

The global result control register selects the behavior of the global result register.

**GLOBRCR**

**Global Result Control Register (0280<sub>H</sub>)**      **Reset Value: 0000 0000<sub>H</sub>**

31	30	29	28	27	26	25	24	23	22	21	20	19	18	17	16
SRG EN	0	0	0	0	0	0	WFR	0	0	0	0	DRCTR			
rw	r	r	r	r	r	r	rw	r	r	r	r	rw			
15	14	13	12	11	10	9	8	7	6	5	4	3	2	1	0
0	0	0	0	0	0	0	0	0	0	0	0	0	0	0	0
r	r	r	r	r	r	r	r	r	r	r	r	r	r	r	r

Field	Bits	Type	Description
0	[15:0]	r	<b>Reserved, write 0, read as 0</b>
DRCTR	[19:16]	rw	<b>Data Reduction Control</b> Defines how result values are stored/accumulated in this register for the final result. The data reduction counter DRC can be loaded from this bitfield. 0000 <sub>B</sub> Data reduction disabled others: see <a href="#">“Function of Bitfield DRCTR” on Page 16-48<sup>1)</sup></a>
0	[23:20]	r	<b>Reserved, write 0, read as 0</b>
WFR	24	rw	<b>Wait-for-Read Mode Enable</b> 0 <sub>B</sub> Overwrite mode 1 <sub>B</sub> Wait-for-read mode enabled for this register
0	[30:25]	r	<b>Reserved, write 0, read as 0</b>

**Versatile Analog-to-Digital Converter (VADC)**

Field	Bits	Type	Description
<b>SRGEN</b>	31	rw	<b>Service Request Generation Enable</b> 0 <sub>B</sub> No service request 1 <sub>B</sub> Service request after a result event

1) Only standard data reduction is available for the global result register, i.e. DMM is assumed as 00<sub>B</sub>.

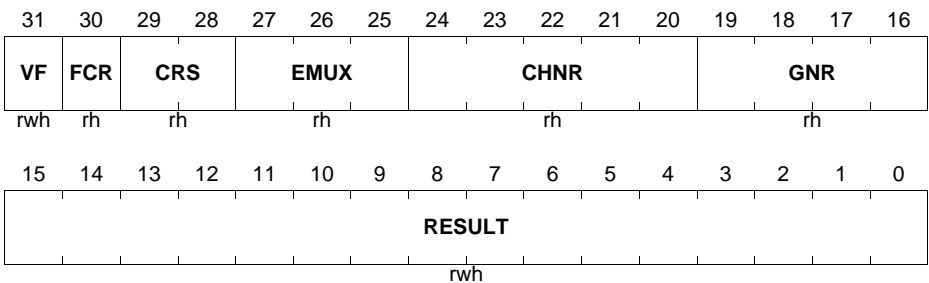
The global result register provides a common storage location for all channels of all groups.

**GLOBRES**

**Global Result Register (0300<sub>H</sub>)**      **Reset Value: 0000 0000<sub>H</sub>**

**GLOBRESD**

**Global Result Register, Debug (0380<sub>H</sub>)**      **Reset Value: 0000 0000<sub>H</sub>**



Field	Bits	Type	Description
<b>RESULT</b>	[15:0]	rwh	<b>Result of most recent conversion</b> The position of the result bits within this bitfield depends on the configured operating mode. <sup>1)</sup> Please, refer to <a href="#">Section 16.11.2</a> .
<b>GNR</b>	[19:16]	rh	<b>Group Number</b> Indicates the group to which the channel number in bitfield CHNR refers.
<b>CHNR</b>	[24:20]	rh	<b>Channel Number</b> Indicates the channel number corresponding to the value in bitfield RESULT.
<b>EMUX</b>	[27:25]	rh	<b>External Multiplexer Setting</b> Indicates the setting of the external multiplexer, corresponding to the value in bitfield RESULT.

**Versatile Analog-to-Digital Converter (VADC)**

Field	Bits	Type	Description
<b>CRS</b>	[29:28]	rh	<b>Converted Request Source</b> Indicates the request source that as requested the conversion to which the result value in bitfield RESULT belongs.
<b>FCR</b>	30	rh	<b>Fast Compare Result</b> Indicates the result of an operation in Fast Compare Mode. 0 <sub>B</sub> Signal level was below compare value 1 <sub>B</sub> Signal level was above compare value
<b>VF</b>	31	rwh	<b>Valid Flag</b> Indicates a new result in bitfield RESULT or bit FCR. 0 <sub>B</sub> Read access: No new valid data available Write access: No effect 1 <sub>B</sub> Read access: Bitfield RESULT contains valid data and has not yet been read, or bit FCR has been updated Write access: Clear this valid flag and the data reduction counter (overrides a hardware set action) <sup>1)</sup>

1) Only writable in register GLOBRES, not in register GLOBRESD.

The valid flag register summarizes the valid flags of all result registers.

**GxVFR (x = 0 - 1)**

**Valid Flag Register, Group x (x \* 0400<sub>H</sub> + 05F8<sub>H</sub>)**      **Reset Value: 0000 0000<sub>H</sub>**

31	30	29	28	27	26	25	24	23	22	21	20	19	18	17	16
0	0	0	0	0	0	0	0	0	0	0	0	0	0	0	0
r	r	r	r	r	r	r	r	r	r	r	r	r	r	r	r
15	14	13	12	11	10	9	8	7	6	5	4	3	2	1	0
VF15	VF14	VF13	VF12	VF11	VF10	VF9	VF8	VF7	VF6	VF5	VF4	VF3	VF2	VF1	VF0
rwh	rwh	rwh	rwh	rwh	rwh	rwh	rwh	rwh	rwh	rwh	rwh	rwh	rwh	rwh	rwh

**Versatile Analog-to-Digital Converter (VADC)**

Field	Bits	Type	Description
<b>VFy</b> <b>(y = 0 - 15)</b>	y	rwh	<b>Valid Flag of Result Register x</b> Indicates a new result in bitfield RESULT or in bit FCR. 0 <sub>B</sub> Read access: No new valid data available Write access: No effect 1 <sub>B</sub> Read access: Result register x contains valid data and has not yet been read, or bit FCR has been updated Write access: Clear this valid flag and bitfield DRC in register GxRESy (overrides a hardware set action)
<b>0</b>	[31:16]	r	<b>Reserved, write 0, read as 0</b>

### 16.16.7 Calibration Registers

The calibration control register CALCTR selects basic calibration features.

#### SHS0\_CALCTR

**Calibration Control Register (4803 40BC<sub>H</sub>)**      **Reset Value: 0010 0400<sub>H</sub>**

31	30	29	28	27	26	25	24	23	22	21	20	19	18	17	16
SU CAL	0	CALMAX				0	SUCALVAL								
w	r	rw				r	rw								
15	14	13	12	11	10	9	8	7	6	5	4	3	2	1	0
0	0	CALGNSTC				0	0	0	0	0	0	0	0	CAL ORD	
r	r	rw				r	r	r	r	r	r	r	r	r	rw

Field	Bits	Type	Description
<b>CALORD</b>	0	rw	<b>Calibration Order</b> 0 <sub>B</sub> Do conversions then calibration 1 <sub>B</sub> Do calibration then conversions
<b>0</b>	[7:1]	r	<b>Reserved, write 0, read as 0</b>

**Versatile Analog-to-Digital Converter (VADC)**

Field	Bits	Type	Description
<b>CALGNSTC</b>	[13:8]	rw	<b>Gain Calibration Sample Time Control</b> Defines the duration of the sample phase for gain calibration cycles. 00 <sub>H</sub> Reserved Others: $t_{SGN} = \text{CALGNSTC} / f_{SH}$ <i>Note: No user control required.</i>
<b>0</b>	[15:14]	r	<b>Reserved, write 0, read as 0</b>
<b>SUCALVAL</b>	[22:16]	rw	<b>Startup Calibration Cycles</b> Defines the number of calibration sequences for the startup calibration. <i>Note: No user control required.</i>
<b>CALMAX</b>	[29:24]	rw	<b>Calibration Maximum Timing</b> Defines the maximum time until the next calibration: $t_{MAX} = 512 / f_{SH} \times (\text{CALMAX} + 1)$
<b>0</b>	30	r	<b>Reserved, write 0, read as 0</b>
<b>SUCAL</b>	31	w	<b>Start-Up Calibration</b> The 0-1 transition of bit SUCAL triggers the start-up calibration phase of the converter. <sup>1)</sup> SUCAL is cleared automatically when the calibration phase begins. 0 <sub>B</sub> No action 1 <sub>B</sub> Initiate the start-up calibration phase (indication in bitfield SHSCFG.STATE)

1) Startup calibration can also be triggered by the known bit SUCAL in register GLOB\_CFG in module VADC\_DIG.

The gain calibration control register CALGC<sub>x</sub> configures the gain calibration features of the associated S&H unit. The calibration values are determined automatically by the calibration mechanism. The can be read to compensate the error introduced by using the alternate reference of another group.

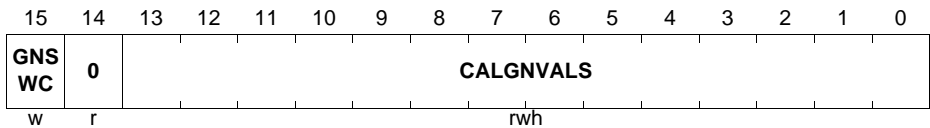
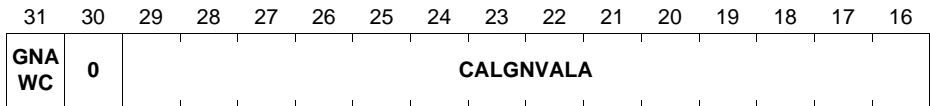
**Versatile Analog-to-Digital Converter (VADC)**

**SHS0\_CALGCx (x = 0 - 1)**

**Gain Calibration Control Register x**

$$(4803\ 40C0_H + x * 4_H)$$

**Reset Value: 2000 2000<sub>H</sub>**



Field	Bits	Type	Description
<b>CALGNVALS</b>	[13:0]	rwh	<b>Gain Calibration Value, Standard Reference</b> Modified by the calibration steps, controls the gain DAC.
<b>0</b>	14	r	<b>Reserved, write 0, read as 0</b>
<b>GNSWC</b>	15	w	<b>Gain Calibration Write Control, Standard</b> 0 <sub>B</sub> No write access to gain calibration parameter 1 <sub>B</sub> CALGNVALS can be written
<b>CALGNVALA</b>	[29:16]	rwh	<b>Gain Calibration Value, Alternate Reference</b> Modified by the calibration steps, controls the gain DAC.
<b>0</b>	30	r	<b>Reserved, write 0, read as 0</b>
<b>GNAWC</b>	31	w	<b>Gain Calibration Write Control, Alternate</b> 0 <sub>B</sub> No write access to gain calibration parameter 1 <sub>B</sub> CALGNVALA can be written

**Versatile Analog-to-Digital Converter (VADC)**

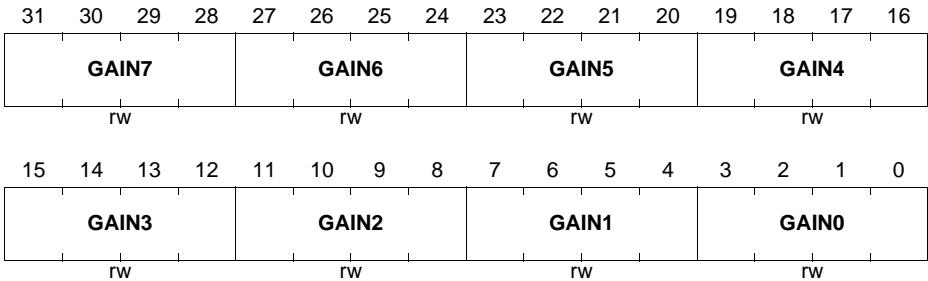
The gain control registers GNCTR<sub>x0</sub> selects the gain level for each input.

**SHS0\_GNCTR00**

**Gain Control Register 00** (4803 4180<sub>H</sub>) **Reset Value: 0000 0000<sub>H</sub>**

**SHS0\_GNCTR10**

**Gain Control Register 10** (4803 4190<sub>H</sub>) **Reset Value: 0000 0000<sub>H</sub>**



Field	Bits	Type	Description
<b>GAIN<sub>z</sub></b> <b>(z = 0 - 7)</b>	[z*4+3: z*4]	rw	<b>Gain Control z</b> 0000 <sub>B</sub> Gain factor = 1 0001 <sub>B</sub> Gain factor = 3 0010 <sub>B</sub> Gain factor = 6 0011 <sub>B</sub> Gain factor = 12 Others: Reserved

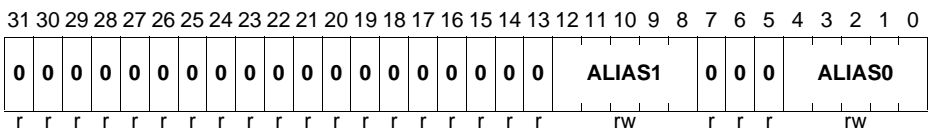
*Note: The first index (x0) indicates the associated S&H unit.  
The channel number is z.*

**16.16.8 Miscellaneous Registers**

The alias register can replace the channel numbers of channels CH0 and CH1 with another channel number. The reset value disables this redirection.

**GxALIAS (x = 0 - 1)**

**Alias Register, Group x** (x \* 0400<sub>H</sub> + 04B0<sub>H</sub>) **Reset Value: 0000 0100<sub>H</sub>**





**Versatile Analog-to-Digital Converter (VADC)**

<b>Field</b>	<b>Bits</b>	<b>Type</b>	<b>Description</b>
<b>ALIAS0</b>	[4:0]	rw	<b>Alias Value for CH0 Conversion Requests</b> Indicates the channel that is converted instead of channel CH0. The conversion is done with the settings defined for channel CH0.
<b>0</b>	[7:5]	r	<b>Reserved, write 0, read as 0</b>
<b>ALIAS1</b>	[12:8]	rw	<b>Alias Value for CH1 Conversion Requests</b> Indicates the channel that is converted instead of channel CH1. The conversion is done with the settings defined for channel CH1.
<b>0</b>	[31:13]	r	<b>Reserved, write 0, read as 0</b>

**Versatile Analog-to-Digital Converter (VADC)**

The local boundary register GxBOUND defines group-specific boundary values or delta limits for Fast Compare Mode.

The global boundary register GLOBBOUND defines general compare values for all channels.

Depending on the conversion width, the respective left 12/10/8 bits of a bitfield are used. For 10/8-bit results, the lower 2/4 bits must be zero!

**GxBOUND (x = 0 - 1)**

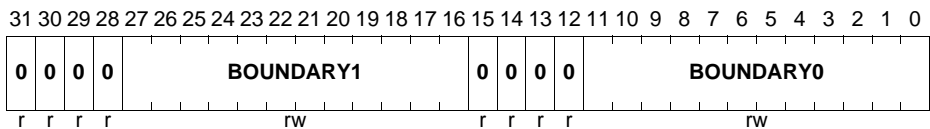
**Boundary Select Register, Group x**

(x \* 0400<sub>H</sub> + 04B8<sub>H</sub>)      **Reset Value: 0000 0000<sub>H</sub>**

**GLOBBOUND**

**Global Boundary Select Register      (00B8<sub>H</sub>)**

**Reset Value: 0000 0000<sub>H</sub>**



Field	Bits	Type	Description
<b>BOUNDARY0</b>	[11:0]	rw	<b>Boundary Value 0 for Limit Checking</b> Standard Mode: This value is compared against the left-aligned conversion result. Fast Compare Mode: This value is added to the reference value (upper delta).
<b>0</b>	[15:12]	r	<b>Reserved, write 0, read as 0</b>
<b>BOUNDARY1</b>	[27:16]	rw	<b>Boundary Value 1 for Limit Checking</b> Standard Mode: This value is compared against the left-aligned conversion result. Fast Compare Mode: This value is subtracted from the reference value (lower delta).
<b>0</b>	[31:28]	r	<b>Reserved, write 0, read as 0</b>

**Versatile Analog-to-Digital Converter (VADC)**

The Boundary Flag Register holds the boundary flags themselves together with bits to select the activation condition and the output signal polarity for each flag.

**GxBFL (x = 0 - 1)**

**Boundary Flag Register, Group x**

(x \* 0400<sub>H</sub> + 04C8<sub>H</sub>)

Reset Value: 0000 0000<sub>H</sub>

31	30	29	28	27	26	25	24	23	22	21	20	19	18	17	16
0	0	0	0	0	0	0	0	0	0	0	0	BFI 3	BFI 2	BFI 1	BFI 0
r	r	r	r	r	r	r	r	r	r	r	r	rw	rw	rw	rw
15	14	13	12	11	10	9	8	7	6	5	4	3	2	1	0
0	0	0	0	BFA 3	BFA 2	BFA 1	BFA 0	0	0	0	0	BFL 3	BFL 2	BFL 1	BFL 0
r	r	r	r	rw	rw	rw	rw	r	r	r	r	rh	rh	rh	rh

Field	Bits	Type	Description
<b>BFLy</b> (y = 0 - 3)	y	rh	<b>Boundary Flag y</b> 0 <sub>B</sub> Passive state: result has not yet crossed the activation boundary (see bitfield BFAy), or selected gate signal is inactive, or this boundary flag is disabled 1 <sub>B</sub> Active state: result has crossed the activation boundary
<b>0</b>	[7:4]	r	<b>Reserved, write 0, read as 0</b>
<b>BFAy</b> (y = 0 - 3)	8 + y	rw	<b>Boundary Flag y Activation Select</b> 0 <sub>B</sub> Set boundary flag BFLy if result is above the defined band or compare value, clear if below 1 <sub>B</sub> Set boundary flag BFLy if result is below the defined band or compare value, clear if above
<b>0</b>	[15:12]	r	<b>Reserved, write 0, read as 0</b>
<b>BFLy</b> (y = 0 - 3)	16 + y	rw	<b>Boundary Flag y Inversion Control</b> 0 <sub>B</sub> Use BFLy directly 1 <sub>B</sub> Invert value and use BFLy
<b>0</b>	[31:20]	r	<b>Reserved, write 0, read as 0</b>

**Versatile Analog-to-Digital Converter (VADC)**

The Boundary Flag Software Register provides means to set or clear each flag by software.

**GxBFLS (x = 0 - 1)**

**Boundary Flag Software Register, Group x**

**(x \* 0400<sub>H</sub> + 04CC<sub>H</sub>)**

**Reset Value: 0000 0000<sub>H</sub>**

31	30	29	28	27	26	25	24	23	22	21	20	19	18	17	16
0	0	0	0	0	0	0	0	0	0	0	0	BFS 3	BFS 2	BFS 1	BFS 0
r	r	r	r	r	r	r	r	r	r	r	r	w	w	w	w
15	14	13	12	11	10	9	8	7	6	5	4	3	2	1	0
0	0	0	0	0	0	0	0	0	0	0	0	BFC 3	BFC 2	BFC 1	BFC 0
r	r	r	r	r	r	r	r	r	r	r	r	w	w	w	w

Field	Bits	Type	Description
<b>BFCy</b> <b>(y = 0 - 3)</b>	y	w	<b>Boundary Flag y Clear</b> 0 <sub>B</sub> No action 1 <sub>B</sub> Clear bit BFLy
<b>0</b>	[15:4]	r	<b>Reserved, write 0, read as 0</b>
<b>BFSy</b> <b>(y = 0 - 3)</b>	16 + y	w	<b>Boundary Flag y Set</b> 0 <sub>B</sub> No action 1 <sub>B</sub> Set bit BFLy
<b>0</b>	[31:20]	r	<b>Reserved, write 0, read as 0</b>

*Note: If a boundary flag is used together with Fast Compare Mode, it is recommended not to direct results from other channels to the corresponding result register.*

**Versatile Analog-to-Digital Converter (VADC)**

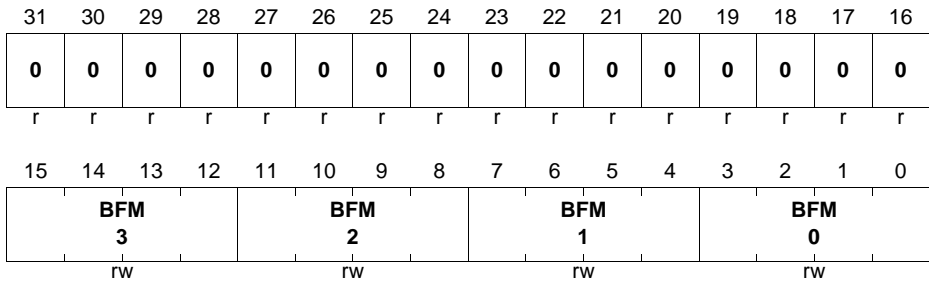
The Boundary Flag Control Register selects the basic operation of the boundary flags.

**GxBFLC (x = 0 - 1)**

**Boundary Flag Control Register, Group x**

$$(x * 0400_H + 04D0_H)$$

**Reset Value: 0000 0000<sub>H</sub>**



Field	Bits	Type	Description
<b>BFM0,</b> <b>BFM1,</b> <b>BFM2,</b> <b>BFM3</b>	[3:0], [7:4], [11:8], [15:12]	rw	<b>Boundary Flag y Mode Control</b> 0000 <sub>B</sub> Disable boundary flag, BFLy is not changed 0001 <sub>B</sub> Always enable boundary flag (follow compare results) 0010 <sub>B</sub> Enable boundary flag while gate of source 0 is active, clear BFLy while gate is inactive 0011 <sub>B</sub> Enable boundary flag while gate of source 1 is active, clear BFLy while gate is inactive others: Reserved
<b>0</b>	[31:16]	r	<b>Reserved, write 0, read as 0</b>

**Versatile Analog-to-Digital Converter (VADC)**

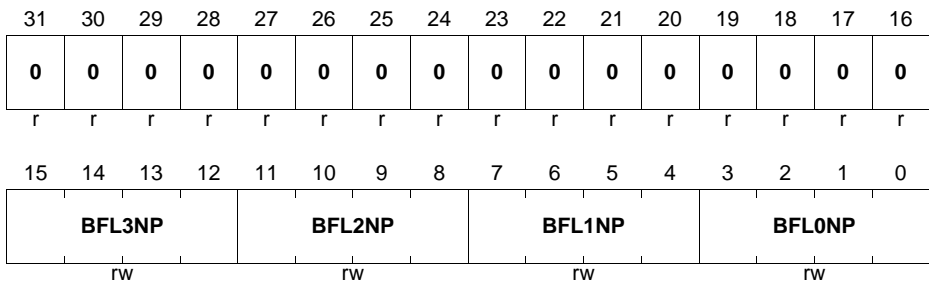
The Boundary Flag Node Pointer Register directs signal GxBFLOUT<sub>y</sub> to alternate on-chip connections with other modules (in addition to the group-specific outputs). Possible targets are the corresponding common service request lines or the common boundary flag outputs (CBFL0 ... CBFL3).

**GxBFLNP (x = 0 - 1)**

**Boundary Flag Node Pointer Register, Group x**

$$(x * 0400_H + 04D4_H)$$

**Reset Value: 0000 FFFF<sub>H</sub>**



Field	Bits	Type	Description
<b>BFL0NP,</b> <b>BFL1NP,</b> <b>BFL2NP,</b> <b>BFL3NP</b>	[3:0], [7:4], [11:8], [15:12]	rw	<b>Boundary Flag y Node Pointer</b> 0000 <sub>B</sub> Select common boundary flag output 0 ... 0011 <sub>B</sub> Select common boundary flag output 3 0100 <sub>B</sub> Select common service request line C0SR0 ... 0111 <sub>B</sub> Select common service request line C0SR3 1111 <sub>B</sub> Disabled, no common output signal others: Reserved
<b>0</b>	[31:16]	r	<b>Reserved, write 0, read as 0</b>

**Versatile Analog-to-Digital Converter (VADC)**

The Synchronization Control Register controls the synchronization of kernels for parallel conversions.

*Note: Program register GxSYNCTR only while bitfield GxARBCFG.ANONS = 00<sub>B</sub> in all ADC kernels of the conversion group. Set the master's bitfield ANONC to 11<sub>B</sub> afterwards.*

**GxSYNCTR (x = 0 - 1)**

**Synchronization Control Register, Group x**

(x \* 0400<sub>H</sub> + 04C0<sub>H</sub>)

Reset Value: 0000 0000<sub>H</sub>

31	30	29	28	27	26	25	24	23	22	21	20	19	18	17	16
0	0	0	0	0	0	0	0	0	0	0	0	0	0	0	0
r	r	r	r	r	r	r	r	r	r	r	r	r	r	r	r
15	14	13	12	11	10	9	8	7	6	5	4	3	2	1	0
0	0	0	0	0	0	0	0	0	0	0	EVALR1	0	0	STSEL	
r	r	r	r	r	r	r	r	r	r	r	rw	r	r	rw	

Field	Bits	Type	Description
<b>STSEL</b>	[1:0]	rw	<b>Start Selection</b> Controls the synchronization mechanism of the ADC kernel. 00 <sub>B</sub> Kernel is synchronization master: Use own bitfield GxARBCFG.ANONC 01 <sub>B</sub> Kernel is synchronization slave: Control information from input CI1 10 <sub>B</sub> Reserved 11 <sub>B</sub> Reserved <i>Note: Control inputs Clx see <a href="#">Figure 16-26</a>, connected kernels see <a href="#">Table 16-13</a>.</i>
<b>0</b>	[3:2]	r	<b>Reserved, write 0, read as 0</b>
<b>EVALR1</b>	4	rw	<b>Evaluate Ready Input R1</b> Enables the ready input signal for a kernel of a conversion group. 0 <sub>B</sub> No ready input control 1 <sub>B</sub> Ready input R1 is considered for the start of a parallel conversion of this conversion group

**Versatile Analog-to-Digital Converter (VADC)**

Field	Bits	Type	Description
<b>0</b>	[31:5]	r	<b>Reserved, write 0, read as 0</b>

**GxEMUXCTR (x = 0 - 1)**

**External Multiplexer Control Register, Group x**

$$(x * 0400_H + 05F0_H)$$

**Reset Value: 0000 0000<sub>H</sub>**

31	30	29	28	27	26	25	24	23	22	21	20	19	18	17	16
<b>EMX WC</b>	<b>EMX CSS</b>	<b>EMX ST</b>	<b>EMX COD</b>	<b>EMUX MODE</b>		<b>EMUX CH</b>									
w	rw	rw	rw	rw		rw									
15	14	13	12	11	10	9	8	7	6	5	4	3	2	1	0
<b>0</b>	<b>0</b>	<b>0</b>	<b>0</b>	<b>0</b>	<b>EMUX ACT</b>		<b>0</b>	<b>0</b>	<b>0</b>	<b>0</b>	<b>0</b>	<b>EMUX SET</b>			
r	r	r	r	r	rh		r	r	r	r	r	r	rw		

Field	Bits	Type	Description
<b>EMUXSET</b>	[2:0]	rw	<b>External Multiplexer Start Selection<sup>1)</sup></b> Defines the initial setting for the external multiplexer.
<b>0</b>	[7:3]	r	<b>Reserved, write 0, read as 0</b>
<b>EMUXACT</b>	[10:8]	rh	<b>External Multiplexer Actual Selection</b> Defines the current value for the external multiplexer selection. This bitfield is loaded from bitfield EMUXSET and modified according to the operating mode selected by bitfield EMUXMODE.
<b>0</b>	[15:11]	r	<b>Reserved, write 0, read as 0</b>
<b>EMUXCH</b>	[25:16]	rw	<b>External Multiplexer Channel Select</b> Defines the channel(s) to which the external multiplexer control is applied. <b>EMXCSS = 0: Channel number</b> , the lower 5 bits select an arbitrary channel (valid numbers are limited by the number of available channels, unused bits shall be 0) <b>EMXCSS = 1: Channel enable</b> , each bit enables the associated channel (multiple channels can be selected/enabled)
<b>0</b>	[25:21]	r	<b>Reserved, write 0, read as 0</b>



**Versatile Analog-to-Digital Converter (VADC)**

Field	Bits	Type	Description
<b>EMUXMODE</b>	[27:26]	rw	<b>External Multiplexer Mode</b> 00 <sub>B</sub> Software control (no hardware action) 01 <sub>B</sub> Steady mode (use EMUXSET value) 10 <sub>B</sub> Single-step mode <sup>1)2)</sup> 11 <sub>B</sub> Sequence mode <sup>1)</sup>
<b>EMXCOD</b>	28	rw	<b>External Multiplexer Coding Scheme</b> 0 <sub>B</sub> Output the channel number in binary code 1 <sub>B</sub> Output the channel number in Gray code
<b>EMXST</b>	29	rw	<b>External Multiplexer Sample Time Control</b> 0 <sub>B</sub> Use STCE whenever the setting changes 1 <sub>B</sub> Use STCE for each conversion of an external channel
<b>EMXCSS</b>	30	rw	<b>External Multiplexer Channel Selection Style</b> 0 <sub>B</sub> Channel number: Bitfield EMUXCH selects an arbitrary channel 1 <sub>B</sub> Channel enable: Each bit of bitfield EMUXCH selects the associated channel for EMUX control
<b>EMXWC</b>	31	w	<b>Write Control for EMUX Configuration</b> 0 <sub>B</sub> No write access to EMUX cfg. 1 <sub>B</sub> Bitfields EMXMODE, EMCOD, EMXST, EMCSS can be written

1) For single-step mode and sequence mode: Select the start value before selecting the respective mode.

2) Single-step mode modifies the EMUX channel number each time an EMUX-enabled channel is converted. Therefore, single-step mode works best with a single channel, because otherwise some external channels may be skipped.

**Versatile Analog-to-Digital Converter (VADC)**

Register EMUXSEL is a global register which assigns an arbitrary group to each of the EMUX interfaces.

**EMUXSEL**

**External Multiplexer Select Register**

(03F0<sub>H</sub>)

Reset Value: 0000 0000<sub>H</sub>

31	30	29	28	27	26	25	24	23	22	21	20	19	18	17	16
0	0	0	0	0	0	0	0	0	0	0	0	0	0	0	0
r	r	r	r	r	r	r	r	r	r	r	r	r	r	r	r
15	14	13	12	11	10	9	8	7	6	5	4	3	2	1	0
0	0	0	0	0	0	0	0	EMUX GRP1			EMUX GRP0				
r	r	r	r	r	r	r	r	rw			rw				

Field	Bits	Type	Description
<b>EMUXGRP0, EMUXGRP1</b>	[3:0], [7:4]	rw	<b>External Multiplexer Group for Interface x</b> Defines the group whose external multiplexer control signals are routed to EMUX interface x. <sup>1)</sup>
<b>0</b>	[31:8]	r	<b>Reserved, write 0, read as 0</b>

1) The pins that are associated with each EMUX interface are listed in [Table 16-15 “Digital Connections in the XMC1200” on Page 16-154](#).

**Versatile Analog-to-Digital Converter (VADC)**

The sigma-delta-loop control register LOOP configures the functionality of the sigma-delta-loop(s).

**SHS0\_LOOP**

**Loop Control Register**

**(4803 4050<sub>H</sub>)**

**Reset Value: 0000 0000<sub>H</sub>**

31	30	29	28	27	26	25	24	23	22	21	20	19	18	17	16
LP EN1	0	0	0	0	0	0	LP SH1	0	0	0	LPCH1				
rw	r	r	r	r	r	r	rw	r	r	r	rw				
15	14	13	12	11	10	9	8	7	6	5	4	3	2	1	0
LP EN0	0	0	0	0	0	0	LP SH0	0	0	0	LPCH0				
rw	r	r	r	r	r	r	rw	r	r	r	rw				

Field	Bits	Type	Description
LPCH0, LPCH1	[4:0], [20:16]	rw	<b>Loop y Channel</b> Selects the input channel, for which the sigma-delta-loop function shall be enabled.
0	[7:5]	r	<b>Reserved, write 0, read as 0</b>
LPSH0, LPSH1	8, 24	rw	<b>Loop y Sample&amp;Hold Unit</b> Selects the S&H unit, to which the indicated channel is assigned.
0	[14:9]	r	<b>Reserved, write 0, read as 0</b>
LPEN0, LPEN1	15, 31	rw	<b>Loop y Enable</b> 0 <sub>H</sub> Off: standard operation 1 <sub>H</sub> ON: sigma-delta-loop is active
0	[23:21]	r	<b>Reserved, write 0, read as 0</b>
0	[30:25]	r	<b>Reserved, write 0, read as 0</b>

*Note: Bitfields LPSHy and LPCHy together select one individual input channel that is associated with the corresponding sigma-delta loop.*

**Versatile Analog-to-Digital Converter (VADC)**

**16.16.9 Service Request Registers**

**GxSEFLAG (x = 0 - 1)**

**Source Event Flag Register, Group x**

$(x * 0400_H + 0588_H)$

**Reset Value: 0000 0000<sub>H</sub>**

31	30	29	28	27	26	25	24	23	22	21	20	19	18	17	16
0	0	0	0	0	0	0	0	0	0	0	0	0	0	0	0
r	r	r	r	r	r	r	r	r	r	r	r	r	r	r	r
15	14	13	12	11	10	9	8	7	6	5	4	3	2	1	0
0	0	0	0	0	0	0	0	0	0	0	0	0	0	SEV 1	SEV 0
r	r	r	r	r	r	r	r	r	r	r	r	r	r	rwh	rwh

Field	Bits	Type	Description
<b>SEV0, SEV1</b>	0, 1	rwh	<b>Source Event 0/1</b> 0 <sub>B</sub> No source event 1 <sub>B</sub> A source event has occurred
<b>0</b>	[31:2]	r	<b>Reserved, write 0, read as 0</b>

*Note: Software can set all flags in register GxSEFLAG and trigger the corresponding event by writing 1 to the respective bit. Writing 0 has no effect.  
Software can clear all flags in register GxSEFLAG by writing 1 to the respective bit in register GxSEFCLR.*

**GxCEFLAG (x = 0 - 1)**

**Channel Event Flag Register, Group x**

$(x * 0400_H + 0580_H)$

**Reset Value: 0000 0000<sub>H</sub>**

31	30	29	28	27	26	25	24	23	22	21	20	19	18	17	16
0	0	0	0	0	0	0	0	0	0	0	0	0	0	0	0
r	r	r	r	r	r	r	r	r	r	r	r	r	r	r	r
15	14	13	12	11	10	9	8	7	6	5	4	3	2	1	0
0	0	0	0	0	0	0	0	CEV 7	CEV 6	CEV 5	CEV 4	CEV 3	CEV 2	CEV 1	CEV 0
r	r	r	r	r	r	r	r	rwh	rwh	rwh	rwh	rwh	rwh	rwh	rwh

**Versatile Analog-to-Digital Converter (VADC)**

Field	Bits	Type	Description
<b>CEVy</b> <b>(y = 0 - 7)</b>	y	rwh	<b>Channel Event for Channel y</b> 0 <sub>B</sub> No channel event 1 <sub>B</sub> A channel event has occurred
<b>0</b>	[31:8]	r	<b>Reserved, write 0, read as 0</b>

*Note: Software can set all flags in register GxCEFLAG and trigger the corresponding event by writing 1 to the respective bit. Writing 0 has no effect.  
Software can clear all flags in register GxCEFLAG by writing 1 to the respective bit in register GxCEFCLR.*

**GxREFLAG (x = 0 - 1)**

**Result Event Flag Register, Group x**

$$(x * 0400_H + 0584_H)$$

**Reset Value: 0000 0000<sub>H</sub>**

31	30	29	28	27	26	25	24	23	22	21	20	19	18	17	16
0	0	0	0	0	0	0	0	0	0	0	0	0	0	0	0
r	r	r	r	r	r	r	r	r	r	r	r	r	r	r	r
15	14	13	12	11	10	9	8	7	6	5	4	3	2	1	0
REV	REV	REV	REV	REV	REV	REV	REV	REV	REV	REV	REV	REV	REV	REV	REV
15	14	13	12	11	10	9	8	7	6	5	4	3	2	1	0
rwh	rwh	rwh	rwh	rwh	rwh	rwh	rwh	rwh	rwh	rwh	rwh	rwh	rwh	rwh	rwh

Field	Bits	Type	Description
<b>REVy</b> <b>(y = 0 - 15)</b>	y	rwh	<b>Result Event for Result Register y</b> 0 <sub>B</sub> No result event 1 <sub>B</sub> New result was stored in register GxRESy
<b>0</b>	[31:16]	r	<b>Reserved, write 0, read as 0</b>

*Note: Software can set all flags in register GxREFLAG and trigger the corresponding event by writing 1 to the respective bit. Writing 0 has no effect.  
Software can clear all flags in register GxREFLAG by writing 1 to the respective bit in register GxREFCLR.*

**Versatile Analog-to-Digital Converter (VADC)**

**GxSEFCLR (x = 0 - 1)**

**Source Event Flag Clear Register, Group x**

$$(x * 0400_H + 0598_H)$$

**Reset Value: 0000 0000<sub>H</sub>**

31	30	29	28	27	26	25	24	23	22	21	20	19	18	17	16
0	0	0	0	0	0	0	0	0	0	0	0	0	0	0	0

15	14	13	12	11	10	9	8	7	6	5	4	3	2	1	0
0	0	0	0	0	0	0	0	0	0	0	0	0	0	SEV 1	SEV 0
r	r	r	r	r	r	r	r	r	r	r	r	r	r	w	w

Field	Bits	Type	Description
SEV0, SEV1	0, 1	w	<b>Clear Source Event 0/1</b> 0 <sub>B</sub> No action 1 <sub>B</sub> Clear the source event flag in GxSEFLAG
0	[31:2]	r	<b>Reserved, write 0, read as 0</b>

**GxCEFCLR (x = 0 - 1)**

**Channel Event Flag Clear Register, Group x**

$$(x * 0400_H + 0590_H)$$

**Reset Value: 0000 0000<sub>H</sub>**

31	30	29	28	27	26	25	24	23	22	21	20	19	18	17	16
0	0	0	0	0	0	0	0	0	0	0	0	0	0	0	0
r	r	r	r	r	r	r	r	r	r	r	r	r	r	r	r

15	14	13	12	11	10	9	8	7	6	5	4	3	2	1	0
0	0	0	0	0	0	0	0	CEV 7	CEV 6	CEV 5	CEV 4	CEV 3	CEV 2	CEV 1	CEV 0
r	r	r	r	r	r	r	r	w	w	w	w	w	w	w	w

Field	Bits	Type	Description
CEVy (y = 0 - 7)	y	w	<b>Clear Channel Event for Channel y</b> 0 <sub>B</sub> No action 1 <sub>B</sub> Clear the channel event flag in GxCEFLAG

**Versatile Analog-to-Digital Converter (VADC)**

Field	Bits	Type	Description
<b>0</b>	[31:8]	r	<b>Reserved, write 0, read as 0</b>

**GxREFCLR (x = 0 - 1)**

**Result Event Flag Clear Register, Group x**

$$(x * 0400_H + 0594_H)$$

**Reset Value: 0000 0000<sub>H</sub>**

31	30	29	28	27	26	25	24	23	22	21	20	19	18	17	16
0	0	0	0	0	0	0	0	0	0	0	0	0	0	0	0
r	r	r	r	r	r	r	r	r	r	r	r	r	r	r	r
15	14	13	12	11	10	9	8	7	6	5	4	3	2	1	0
REV 15	REV 14	REV 13	REV 12	REV 11	REV 10	REV 9	REV 8	REV 7	REV 6	REV 5	REV 4	REV 3	REV 2	REV 1	REV 0
w	w	w	w	w	w	w	w	w	w	w	w	w	w	w	w

Field	Bits	Type	Description
<b>REVy</b> <b>(y = 0 - 15)</b>	y	w	<b>Clear Result Event for Result Register y</b> 0 <sub>B</sub> No action 1 <sub>B</sub> Clear the result event flag in GxREFLAG
<b>0</b>	[31:16]	r	<b>Reserved, write 0, read as 0</b>

**GLOBEFLAG**

**Global Event Flag Register**

$$(00E0_H)$$

**Reset Value: 0000 0000<sub>H</sub>**

31	30	29	28	27	26	25	24	23	22	21	20	19	18	17	16
0	0	0	0	0	0	0	REV GLB CLR	0	0	0	0	0	0	0	SEV GLB CLR
r	r	r	r	r	r	r	w	r	r	r	r	r	r	r	w
15	14	13	12	11	10	9	8	7	6	5	4	3	2	1	0
0	0	0	0	0	0	0	REV GLB	0	0	0	0	0	0	0	SEV GLB
r	r	r	r	r	r	r	rwh	r	r	r	r	r	r	r	rwh

**Versatile Analog-to-Digital Converter (VADC)**

Field	Bits	Type	Description
<b>SEVGLB</b>	0	rwh	<b>Source Event (Background)</b> 0 <sub>B</sub> No source event 1 <sub>B</sub> A source event has occurred
<b>0</b>	[7:1]	r	<b>Reserved, write 0, read as 0</b>
<b>REVGLB</b>	8	rwh	<b>Global Result Event</b> 0 <sub>B</sub> No result event 1 <sub>B</sub> New result was stored in register GLOBRES
<b>0</b>	[15:9]	r	<b>Reserved, write 0, read as 0</b>
<b>SEVGLBCLR</b>	16	w	<b>Clear Source Event (Background)</b> 0 <sub>B</sub> No action 1 <sub>B</sub> Clear the source event flag SEVGLB
<b>0</b>	[23:17]	r	<b>Reserved, write 0, read as 0</b>
<b>REVGLBCLR</b>	24	w	<b>Clear Global Result Event</b> 0 <sub>B</sub> No action 1 <sub>B</sub> Clear the result event flag REVGLB
<b>0</b>	[31:25]	r	<b>Reserved, write 0, read as 0</b>

*Note: Software can set flags REVGLB and SEVGLB and trigger the corresponding event by writing 1 to the respective bit. Writing 0 has no effect.*

*Software can clear these flags by writing 1 to bit REVGLBCLR and SEVGLBCLR, respectively.*

*Setting both bits (e.g. SEVGLB and SEVGLBCLR) simultaneously clears the corresponding flag (e.g. SEVGLB).*

**GxSEVNP (x = 0 - 1)**

**Source Event Node Pointer Register, Group x**

(x \* 0400<sub>H</sub> + 05C0<sub>H</sub>)      **Reset Value: 0000 0000<sub>H</sub>**

31	30	29	28	27	26	25	24	23	22	21	20	19	18	17	16
0	0	0	0	0	0	0	0	0	0	0	0	0	0	0	0
r	r	r	r	r	r	r	r	r	r	r	r	r	r	r	r
15	14	13	12	11	10	9	8	7	6	5	4	3	2	1	0
0	0	0	0	0	0	0	0	SEV1NP			SEV0NP				
r	r	r	r	r	r	r	r	rw			rw				



**Versatile Analog-to-Digital Converter (VADC)**

Field	Bits	Type	Description
<b>SEV0NP, SEV1NP</b>	[3:0], [7:4]	rw	<b>Service Request Node Pointer Source Event i<sup>1)</sup></b> Routes the corresponding event trigger to one of the service request lines (nodes). 0000 <sub>B</sub> Select service request line 0 of group x ... 0011 <sub>B</sub> Select service request line 3 of group x 0100 <sub>B</sub> Select shared service request line 0 ... 0111 <sub>B</sub> Select shared service request line 3 1xxx <sub>B</sub> Reserved <i>Note: For shared service request lines see common groups in <a href="#">Table 16-12</a>.</i>
<b>0</b>	[31:8]	r	<b>Reserved, write 0, read as 0</b>

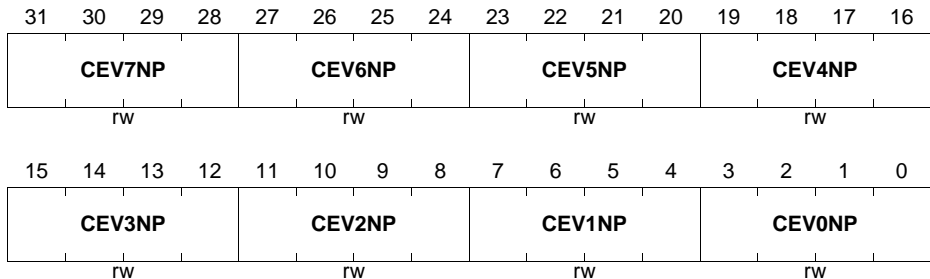
1) Source 0 is an 8-stage queued source, source 1 is a channel scan source.

**GxCEVNP0 (x = 0 - 1)**

**Channel Event Node Pointer Register 0, Group x**

$$(x * 0400_H + 05A0_H)$$

**Reset Value: 0000 0000<sub>H</sub>**



**Versatile Analog-to-Digital Converter (VADC)**

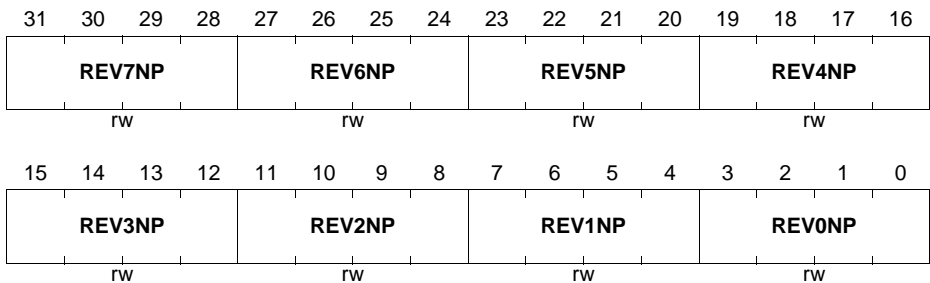
Field	Bits	Type	Description
<b>CEV0NP,</b> <b>CEV1NP,</b> <b>CEV2NP,</b> <b>CEV3NP,</b> <b>CEV4NP,</b> <b>CEV5NP,</b> <b>CEV6NP,</b> <b>CEV7NP</b>	[3:0], [7:4], [11:8], [15:12], [19:16], [23:20], [27:24], [31:28]	rw	<b>Service Request Node Pointer Channel Event i</b> Routes the corresponding event trigger to one of the service request lines (nodes). 0000 <sub>B</sub> Select service request line 0 of group x ... 0011 <sub>B</sub> Select service request line 3 of group x 0100 <sub>B</sub> Select shared service request line 0 ... 0111 <sub>B</sub> Select shared service request line 3 1xxx <sub>B</sub> Reserved <i>Note: For shared service request lines see common groups in <a href="#">Table 16-12</a>.</i>

**GxREVNP0 (x = 0 - 1)**

**Result Event Node Pointer Register 0, Group x**

$$(x * 0400_H + 05B0_H)$$

**Reset Value: 0000 0000<sub>H</sub>**



**Versatile Analog-to-Digital Converter (VADC)**

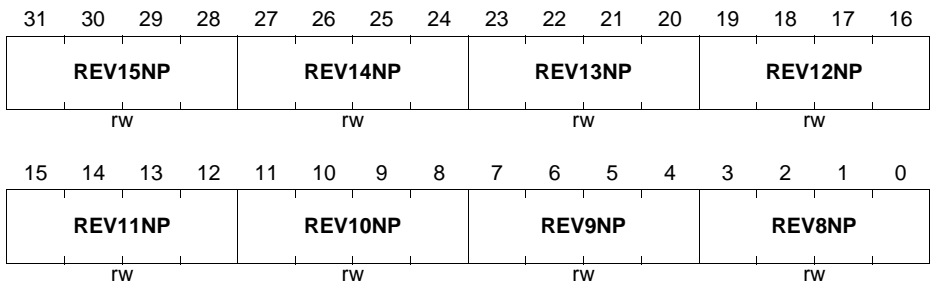
Field	Bits	Type	Description
REV0NP, REV1NP, REV2NP, REV3NP, REV4NP, REV5NP, REV6NP, REV7NP	[3:0], [7:4], [11:8], [15:12], [19:16], [23:20], [27:24], [31:28]	rw	<p><b>Service Request Node Pointer Result Event i</b></p> <p>Routes the corresponding event trigger to one of the service request lines (nodes).</p> <p>0000<sub>B</sub>Select service request line 0 of group x ... 0011<sub>B</sub>Select service request line 3 of group x 0100<sub>B</sub>Select shared service request line 0 ... 0111<sub>B</sub>Select shared service request line 3 1xxx<sub>B</sub> Reserved</p> <p><i>Note: For shared service request lines see common groups in <a href="#">Table 16-12</a>.</i></p>

**GxREVNP1 (x = 0 - 1)**

**Result Event Node Pointer Register 1, Group x**

$$(x * 0400_H + 05B4_H)$$

**Reset Value: 0000 0000<sub>H</sub>**



**Versatile Analog-to-Digital Converter (VADC)**

Field	Bits	Type	Description
REV8NP, REV9NP, REV10NP, REV11NP, REV12NP, REV13NP, REV14NP, REV15NP	[3:0], [7:4], [11:8], [15:12], [19:16], [23:20], [27:24], [31:28]	rw	<p><b>Service Request Node Pointer Result Event i</b></p> <p>Routes the corresponding event trigger to one of the service request lines (nodes).</p> <p>0000<sub>B</sub>Select service request line 0 of group x ... 0011<sub>B</sub>Select service request line 3 of group x 0100<sub>B</sub>Select shared service request line 0 ... 0111<sub>B</sub>Select shared service request line 3 1xxx<sub>B</sub> Reserved</p> <p><i>Note: For shared service request lines see common groups in <a href="#">Table 16-12</a>.</i></p>

**GLOBEVNP**

**Global Event Node Pointer Register**

(0140<sub>H</sub>)

Reset Value: 0000 0000<sub>H</sub>

31	30	29	28	27	26	25	24	23	22	21	20	19	18	17	16
0	0	0	0	0	0	0	0	0	0	0	0	REV0NP			
r	r	r	r	r	r	r	r	r	r	r	r	rw			
15	14	13	12	11	10	9	8	7	6	5	4	3	2	1	0
0	0	0	0	0	0	0	0	0	0	0	0	SEV0NP			
r	r	r	r	r	r	r	r	r	r	r	r	rw			

**Versatile Analog-to-Digital Converter (VADC)**

Field	Bits	Type	Description
<b>SEV0NP</b>	[3:0]	rw	<p><b>Service Request Node Pointer Backgr. Source</b> Routes the corresponding event trigger to one of the service request lines (nodes). 0000<sub>B</sub>Select shared service request line 0 of common service request group 0 ... 0011<sub>B</sub>Select shared service request line 3 of common service request group 0 others: Reserved <i>Note: For shared service request lines see common groups in <a href="#">Table 16-12</a>.</i></p>
<b>0</b>	[15:4]	r	<b>Reserved, write 0, read as 0</b>
<b>REV0NP</b>	[19:16]	rw	<p><b>Service Request Node Pointer Global Result</b> Routes the corresponding event trigger to one of the service request lines (nodes). 0000<sub>B</sub>Select shared service request line 0 of common service request group 0 ... 0011<sub>B</sub>Select shared service request line 3 of common service request group 0 others: Reserved <i>Note: For shared service request lines see common groups in <a href="#">Table 16-12</a>.</i></p>
<b>0</b>	[31:20]	r	<b>Reserved, write 0, read as 0</b>

**Versatile Analog-to-Digital Converter (VADC)**

**GxSRACT (x = 0 - 1)**

**Service Request Software Activation Trigger, Group x**

$$(x * 0400_H + 05C8_H)$$

**Reset Value: 0000 0000<sub>H</sub>**

31	30	29	28	27	26	25	24	23	22	21	20	19	18	17	16
0	0	0	0	0	0	0	0	0	0	0	0	0	0	0	0
r	r	r	r	r	r	r	r	r	r	r	r	r	r	r	r
15	14	13	12	11	10	9	8	7	6	5	4	3	2	1	0
0	0	0	0	AS SR3	AS SR2	AS SR1	AS SR0	0	0	0	0	0	0	AG SR1	AG SR0
r	r	r	r	w	w	w	w	r	r	r	r	r	r	w	w

Field	Bits	Type	Description
<b>AGSRy</b> (y = 0 - 1)	y	w	<b>Activate Group Service Request Node y</b> 0 <sub>B</sub> No action 1 <sub>B</sub> Activate the associated service request line
<b>0</b>	[7:2]	r	<b>Reserved, write 0, read as 0</b>
<b>ASSRy</b> (y = 0 - 3)	8 + y	w	<b>Activate Shared Service Request Node y</b> 0 <sub>B</sub> No action 1 <sub>B</sub> Activate the associated service request line
<b>0</b>	[31:12]	r	<b>Reserved, write 0, read as 0</b>

## 16.17 Interconnects

This section describes the actual implementation of the VADC module into the XMC1200, i.e. the incorporation into the microcontroller system.

### 16.17.1 Product-Specific Configuration

The functional description describes the features and operating modes of the A/D Converters in a general way. This section summarizes the configuration that is available in this product (XMC1200).

Each converter group is equipped with a separate sample and hold stage and a dedicated analog input multiplexer.

**Table 16-12 General Converter Configuration in the XMC1200**

<b>Converter Group</b>	<b>Input Channels</b>	<b>Channels with Alternate GND</b>	<b>12-bit Performance</b>	<b>Common Service Request Group</b>
G0	0 ... 7	8	Calibrated S&H-ADC	C0
G1	0 ... 7	8		C0

### Synchronization Groups in the XMC1200

The converter kernels in the XMC1200 can be connected to synchronization groups to achieve parallel conversion of several input channels.

**Table 16-13** summarizes which kernels can be synchronized for parallel conversions.

**Table 16-13 Synchronization Groups in the XMC1200**

ADC Kernel	Synchr. Group	Master selected by control input C1x <sup>1)</sup>	
		C10 <sup>2)</sup>	C11
ADC00	A	ADC00	ADC01
ADC01	A	ADC01	ADC00

- 1) The control input is selected by bitfield STSEL in register **GxSYNCTR (x = 0 - 1)**. Select the corresponding ready inputs accordingly by bits EVALRx.
- 2) Control input C10 always selects the own control signals of the corresponding ADC kernel. This selection is meant for the synchronization master or for stand-alone operation.



**Versatile Analog-to-Digital Converter (VADC)**

**16.17.2 Analog Module Connections in the XMC1200**

The VADC module accepts a number of analog input signals. The analog input multiplexers select the input channels to be converted from the signals available in this product.

The exact number of analog input channels and the available connection to port pins depend on the employed product type (see also [Table 16-12](#)). A summary of channels enclosing all versions of the XMC1200 can be found in [Table 16-14](#).

**Table 16-14 Analog Connections in the XMC1200**

Signal	Dir.	Source/Destin.	Description
<b>Supply Voltage and Reference Voltage</b>			
$V_{DDM}$	I	VDD	positive supply voltage
$V_{SSM}$	I	VSS	negative supply voltage
$V_{AREF}$	I	VDD	positive analog reference
$V_{AGND}$	I	VSS	negative analog reference
<b>Group 0 Analog Inputs</b>			
G0CH0	I	P2.6	analog input channel 0 of group 0
G0CH1	I	P2.8	analog input channel 1 of group 0
G0CH2	I	P2.9	analog input channel 2 of group 0
G0CH3	I	P2.10	analog input channel 3 of group 0
G0CH4	I	P2.11	analog input channel 4 of group 0
G0CH5	I	P2.0	analog input channel 5 of group 0
G0CH6	I	P2.1	analog input channel 6 of group 0
G0CH7	I	P2.2	analog input channel 7 of group 0
<b>Group 1 Analog Inputs</b>			
G1CH0	I	P2.8	analog input channel 0 of group 1
G1CH1	I	P2.7	analog input channel 1 of group 1
G1CH2	I	P2.10	analog input channel 2 of group 1
G1CH3	I	P2.11	analog input channel 3 of group 1
G1CH4	I	P2.9	analog input channel 4 of group 1
G1CH5	I	P2.3	analog input channel 5 of group 1
G1CH6	I	P2.4	analog input channel 6 of group 1
G1CH7	I	P2.5	analog input channel 7 of group 1

**Versatile Analog-to-Digital Converter (VADC)**

**16.17.3 Digital Module Connections in the XMC1200**

The VADC module accepts a number of digital input signals and generates a number of output signals. This section summarizes the connection of these signals to other on-chip modules or to external resources via port pins.

*Note: The control bitfields for triggers and gates select the corresponding multiplexer input. Values 0000<sub>B</sub> ... 1111<sub>B</sub> select inputs with suffix -A ... -P.*

**Table 16-15 Digital Connections in the XMC1200**

Signal	Dir.	Source/Destin.	Description
<b>Gate Inputs for Each Group</b>			
GxREQGTA	I	CCU40.ST3	Gating input A
GxREQGTB	I	CCU40.ST2	Gating input B
GxREQGTC	I	CCU40.ST1	Gating input C
GxREQGTD	I	CCU40.ST0	Gating input D
GxREQGTE	I	Reserved	Gating input E
GxREQGTF	I	Reserved	Gating input F
GxREQGTG	I	0	Gating input G
GxREQGTH	I	0	Gating input H
GxREQGTI	I (s)	LEDTS0.FN	Gating input I
GxREQGTJ	I (s)	LEDTS1.FN	Gating input J
GxREQGTK	I (s)	ERU0.PDOOUT2	Gating input K
GxREQGTL	I (s)	ERU0.PDOOUT3	Gating input L
GxREQGTM	I	Reserved	Gating input M
GxREQGTN	I	Reserved	Gating input N
GxREQGTO	I	ERU0.PDOOUT0	Gating input O
GxREQGTP	I	ERU0.PDOOUT1	Gating input E
GxREQGTSEL	O	GxREQTRP <sup>1)</sup>	Selected gating signal of the respective source
<b>Gate Inputs for Global Background Source</b>			
BGREQGTA	I	CCU40.ST3	Gating input A, background source
BGREQGTB	I	CCU40.ST2	Gating input B, background source
BGREQGTC	I	CCU40.ST1	Gating input C, background source
BGREQGTD	I	CCU40.ST0	Gating input D, background source
BGREQGTE	I	Reserved	Gating input E, background source

**Versatile Analog-to-Digital Converter (VADC)**

**Table 16-15 Digital Connections in the XMC1200 (cont'd)**

<b>Signal</b>	<b>Dir.</b>	<b>Source/Destin.</b>	<b>Description</b>
BGREQGT F	I	Reserved	Gating input F, background source
BGREQGT G	I	0	Gating input G, background source
BGREQGT H	I	0	Gating input H, background source
BGREQGT I	I (s)	LEDTS0.FN	Gating input I, background source
BGREQGT J	I (s)	LEDTS1.FN	Gating input J, background source
BGREQGT K	I (s)	ERU0.PDOU T2	Gating input K, background source
BGREQGT L	I (s)	ERU0.PDOU T3	Gating input L, background source
BGREQGT M	I	Reserved	Gating input M, background source
BGREQGT N	I	Reserved	Gating input N, background source
BGREQGT O	I	ERU0.PDOU T0	Gating input O, background source
BGREQGT P	I	ERU0.PDOU T1	Gating input E, background source
BGREQGTSEL	O	BGREQTRP <sup>1)</sup>	Selected gating signal

**Trigger Inputs for Each Group**

GxREQTR A	I	CCU40.SR2	Trigger input A
GxREQTR B	I	CCU40.SR3	Trigger input B
GxREQTR C	I	0	Trigger input C
GxREQTR D	I	0	Trigger input D
GxREQTR E	I	0	Trigger input E
G0REQTR F	I	BCCU0.TRIGOU T0	Trigger input F
G1REQTR F	I	BCCU0.TRIGOU T1	Trigger input F
GxREQTR G	I	ERU0.IOU T2	Trigger input G
GxREQTR H	I	ERU0.IOU T3	Trigger input H
GxREQTR I	I (s)	Reserved	Trigger input I
GxREQTR J	I (s)	Reserved	Trigger input J
GxREQTR K	I (s)	0	Trigger input K
GxREQTR L	I (s)	0	Trigger input L
GxREQTR M	I	ERU0.IOU T0	Trigger input M
GxREQTR N	I	ERU0.IOU T1	Trigger input N
GxREQTR O	I	Reserved	Trigger input O

**Versatile Analog-to-Digital Converter (VADC)**

**Table 16-15 Digital Connections in the XMC1200 (cont'd)**

Signal	Dir.	Source/Destin.	Description
GxREQTRP	I	GxREQGTSEL <sup>1)</sup>	Extend triggers to selected gating input of the respective source
GxREQTRSEL	O	-	Selected trigger signal of the respective source

**Trigger Inputs for Global Background Source**

BGREQTRA	I	CCU40.SR2	Trigger input A, background source
BGREQTRB	I	CCU40.SR3	Trigger input B, background source
BGREQTRC	I	0	Trigger input C, background source
BGREQTRD	I	0	Trigger input D, background source
BGREQTRE	I	0	Trigger input E, background source
BGREQTRF	I	BCCU0.TRIGOUT0	Trigger input F, background source
BGREQTRG	I	ERU0.IOUT2	Trigger input G, background source
BGREQTRH	I	ERU0.IOUT3	Trigger input H, background source
BGREQTRI	I (s)	Reserved	Trigger input I, background source
BGREQTRJ	I (s)	Reserved	Trigger input J, background source
BGREQTRK	I (s)	0	Trigger input K, background source
BGREQTRL	I (s)	0	Trigger input L, background source
BGREQTRM	I	ERU0.IOUT0	Trigger input M, background source
BGREQTRN	I	ERU0.IOUT1	Trigger input N, background source
BGREQTRO	I	Reserved	Trigger input O, background source
BGREQTRP	I	BGREQGTSEL <sup>1)</sup>	Extend triggers to selected gating input of the background source
BGREQTRSEL	O	-	Selected trigger signal of the background source

**System-Internal Connections**

G0SAMPLE	O	-	Indicates the input signal sample phase
G1SAMPLE	O	-	Indicates the input signal sample phase
G0ARBCNT	O	CCU40.IN3G	Outputs a (count) pulse for each arbiter round
G1ARBCNT	O	-	Outputs a (count) pulse for each arbiter round

**Versatile Analog-to-Digital Converter (VADC)**

**Table 16-15 Digital Connections in the XMC1200 (cont'd)**

<b>Signal</b>	<b>Dir.</b>	<b>Source/Destin.</b>	<b>Description</b>
G0SR0	O	NVIC (17)	Service request 0 of group 0
G0SR1	O	NVIC (18)	Service request 1 of group 0
G0SR2	O	-	Service request 2 of group 0
G0SR3	O	-	Service request 3 of group 0
G1SR0	O	NVIC (19)	Service request 0 of group 1
G1SR1	O	NVIC (20)	Service request 1 of group 1
G1SR2	O	-	Service request 2 of group 1
G1SR3	O	-	Service request 3 of group 1
C0SR0	O	NVIC (15)	Service request 0 of common block 0
C0SR1	O	NVIC (16)	Service request 1 of common block 0
C0SR2	O	ERU0.0GU02 ERU0.0GU12	Service request 2 of common block 0
C0SR3	O	ERU0.0GU22 ERU0.0GU32	Service request 3 of common block 0
EMUX00	O	P0.4 P1.1	Control of external analog multiplexer interface 0
EMUX01	O	P0.3 P1.2	
EMUX02	O	P0.2 P1.3	
EMUX10	O	P1.4	Control of external analog multiplexer interface 1
EMUX11	O	P1.5	
EMUX12	O	Reserved	
CBFLOUT0	O	Reserved	Common boundary flag output 0
CBFLOUT1	O	Reserved	Common boundary flag output 1
CBFLOUT2	O	Reserved	Common boundary flag output 2
CBFLOUT3	O	Reserved	Common boundary flag output 3
G0BFLOUT0	O	ERU0.0A3	Boundary flag 0 output of group 0
G1BFLOUT0	O	ERU0.0B3	Boundary flag 0 output of group 1
G0BFLOUT1	O	ERU0.1A3	Boundary flag 1 output of group 0
G1BFLOUT1	O	ERU0.1B3	Boundary flag 1 output of group 1
G0BFLOUT2	O	ERU0.2A3	Boundary flag 2 output of group 0

**Versatile Analog-to-Digital Converter (VADC)**

**Table 16-15 Digital Connections in the XMC1200 (cont'd)**

<b>Signal</b>	<b>Dir.</b>	<b>Source/Destin.</b>	<b>Description</b>
G1BFLOUT2	O	ERU0.2B3	Boundary flag 2 output of group 1
G0BFLOUT3	O	ERU0.3A3	Boundary flag 3 output of group 0
G1BFLOUT3	O	ERU0.3B3	Boundary flag 3 output of group 1

1) Internal signal connection.

## 17 Analog Comparator (ACMP) and Out of Range Comparator (ORC)

This chapter describes the controls for analog comparator (ACMP) and out of range comparator (ORC).

### 17.1 Overview

This section gives an overview about the feature set of the Analog comparator and the Out of Range Comparator. In XMC1200, there are up to 3 Analog Comparators (ACMPx [x=0-2]) and 8 Out of Range Comparator (ORCx [x=0-7]).

#### 17.1.1 Features

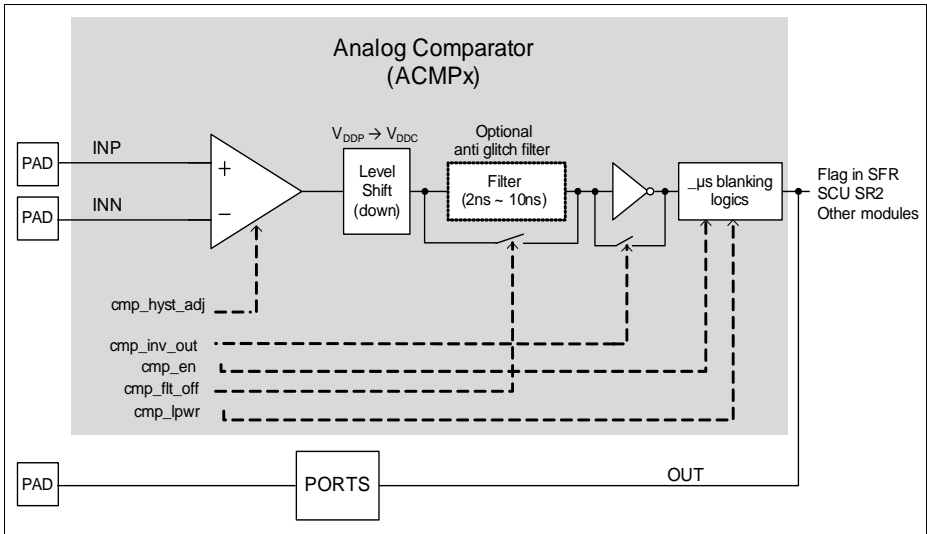
The following features are provided:

- Out of Range Comparator (ORC)
  - Over-voltage monitoring for the analog inputs pins of the ADC module
- Analog Comparator (ACMP)
  - Monitor external voltage level
  - Selectable low power mode
  - Inverted output option

### 17.2 Analog Comparator (ACMP)

**Figure 17-2** shows the block diagram of a Analog Comparator unit.

**Analog Comparator (ACMP) and Out of Range Comparator**



**Figure 17-1 Block diagram of Analog Comparator**

Input INP is compared with input INN in the pad voltage domain. The digital comparator output signal is shifted down from  $V_{DDP}$  power supply voltage level to  $V_{DDC}$  core voltage level. A filter (if enabled) absorbs generated spikes and can be controlled via bit ANACMPx.CMP\_FLT\_OFF. To prevent undefined states immediately after comparator enabling, a blanking module is added to ensure a stable output during transition state. The blanking time is in a range of few usec. With the help of bit ANACMPx.CMP\_INV\_OUT, the comparator output is inverted. The output of the comparator could be used to wake-up the system from power save mode. It can also be observed from a pin.

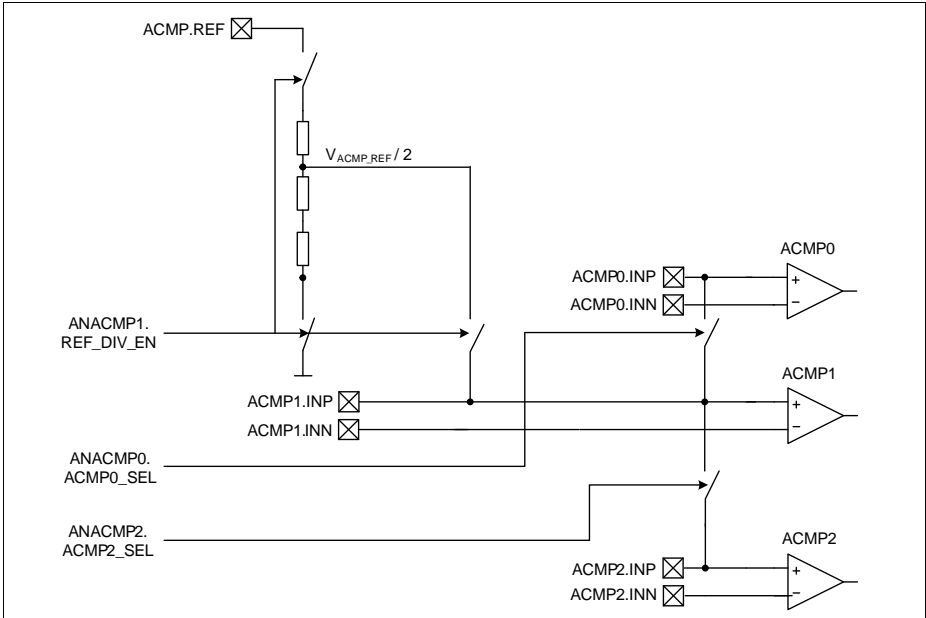
The analog comparator can be switched off via bit CMP\_EN bit in the ANACMPx register to save power.

**Divided Reference Voltage**

A resistor chain (in the order of 500kOhm) divides the reference voltage value from ACMP.REF input if bit ANACMP1.REF\_DIV\_EN is set. According to [Figure 17-2](#), the divided voltage is delivered to pin ACMP1.INP. With bit ANACMP0.ACMP0\_SEL and ANACMP2.ACMP2\_SEL, all other comparators can be supplied by this divided reference voltage.



**Analog Comparator (ACMP) and Out of Range Comparator**



**Figure 17-2 Analog Comparator Reference Divider Function**

**Low Power Mode**

A low power state helps to reduce the total power consumption e.g. during sleep mode. It can be enabled by setting ANACMPx.LPWR to HIGH. In this mode, the analog comparators may show a reduced performance. When switching back to normal mode, the blanking time applies to ensure a stable output.

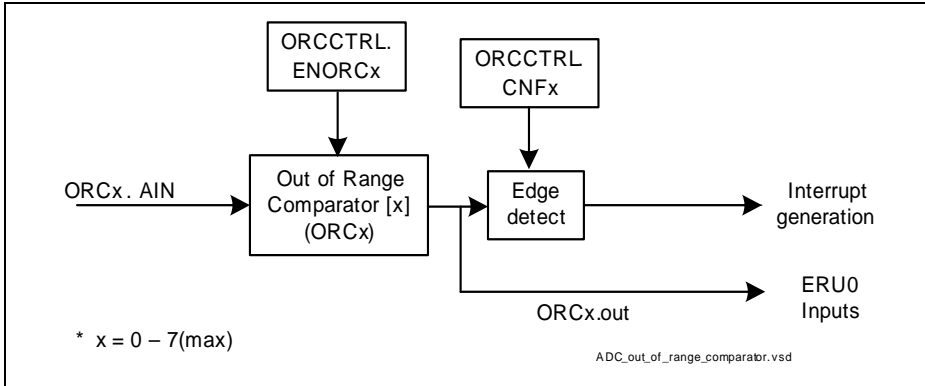
**17.3 Out of Range Comparator (ORC)**

Out of range comparator (ORC) is built into every ADC channel which will trigger other modules or an interrupt when voltage out of range condition occurs. This happens when voltage at the input channel rises to above  $V_{DDP}$  level or when the input channel falls to a voltage below  $V_{DDP}$  level.

The out of range comparator is connected to ERU0 modules. All out of range comparator events is assigned to one interrupt node.

Before using the out of range comparator, it has to be enabled by setting the bits at **ORCTRL.ENORCx** and configuring it to detect voltage higher or lower than  $V_{DDP}$  by setting bits **ORCTRL.CNFx** (See **Figure 17-3**).

**Analog Comparator (ACMP) and Out of Range Comparator**



**Figure 17-3 Out of range comparator**

When a voltage out of range event occurs, the event sets an interrupt request through SCU.SR2 and triggers ERU0 through output of ORC (ORCx.out).

In XMC1200, ORCx.AIN[x=0-7] are connected to P2.2 - P2.9 respectively.

### 17.4 Service Request Generation

Both the ACMP and ORC has a service request output each. They are combined into a single output and connected to one of the interrupt node in the Nested Vectored Interrupt Controller (NVIC) via SCU.SR2.

The service request handling is part of the GCU block in SCU module. Refer to the “Service Request” description in the GCU section which is part of the SCU chapter for more details.

### 17.5 Debug Behavior

ACMPx and ORCx are not affected by the debug activities performed using external debug probe.

### 17.6 Registers

ACMP registers are accessible via the APB bus. ORC registers are accessible via the AHB bus. The absolute register address is calculated by adding:

Module Base Address + Offset Address

Following access to ACMP/ORC SFRs result in an AHB/APB error response:

- Read or write access to undefined address
- Write access to read-only registers

**Analog Comparator (ACMP) and Out of Range Comparator**

**Table 17-1 Registers Address Space**

Module	Base Address	End Address	Note
COMPARATOR	4001 0000 <sub>H</sub>	4001 FFFF <sub>H</sub>	System Control Unit Registers

**Table 17-2 Registers Overview**

Short Name	Description	Offset Addr. <sup>1)</sup>	Access Mode		Description See
			Read	Write	
<b>ORCx Registers</b>					
ORCTRL	Out of Range Comparator Control Register	0500 <sub>H</sub>	U, PV 32	U, PV 32	<a href="#">Page 17-6</a>
<b>ACMPx Registers</b>					
ANACMP0	Analog Comparator 0 Control Register	105C <sub>H</sub>	U, PV	U, PV	<a href="#">Page 17-7</a>
ANACMP1	Analog Comparator 1 Control Register	1060 <sub>H</sub>	U, PV	U, PV	<a href="#">Page 17-7</a>
ANACMP2	Analog Comparator 2 Control Register	1064 <sub>H</sub>	U, PV	U, PV	<a href="#">Page 17-7</a>

1) The absolute register address is calculated as follows:  
Module Base Address + Offset Address (shown in this column)

## 17.6.1 ORC Register

### ORCTRL

Out of Range Comparator Control Register

This register enables the out of range comparator and selects the rising edge trigger or falling edge trigger for the flag register.

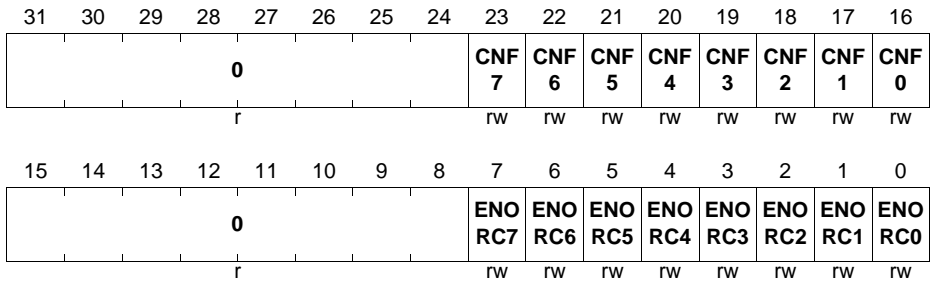
**Analog Comparator (ACMP) and Out of Range Comparator**

**ORCTRL**

**Out Of Range Comparator Control Register**

(0500<sub>H</sub>)

Reset Value: 0000 0000<sub>H</sub>



Field	Bits	Type	Description
<b>ENORCx</b> (x = 0 - 7)	x	rw	<p><b>Enable Out of Range Comparator x</b></p> <p>This bit defines if the out of range comparator is enabled in the corresponding analog input channel.</p> <p>0<sub>B</sub> Out of range comparator disabled. 1<sub>B</sub> Out of range comparator enabled.</p>
<b>CNFx</b> (x = 0 - 7)	x+16	rw	<p><b>Out of Range Comparator Flag x</b></p> <p>This bit selects CHx rising edge trigger or falling edge trigger for out of range comparator flag register.</p> <p>0<sub>B</sub> Falling edge trigger out of range event register. 1<sub>B</sub> Rising edge trigger out of range event register.</p>
<b>0</b>	[15:8], [31:24]	r	<p><b>Reserved</b></p> <p>Read as 0; should be written with 0.</p>

**17.6.2 ACMP Registers**

**ANACMP0**

Analog Comparator 0 Control Register

**Analog Comparator (ACMP) and Out of Range Comparator**

**ANACMP0**

**Analog Comparator 0 Control Register(105C<sub>H</sub>)**

**Reset Value: 0020<sub>H</sub>**

15	14	13	12	11	10	9	8	7	6	5	4	3	2	1	0
CMP_OUT			0				CMP_LPWR	0	ACMP0_SEL	CMP_HYST_ADJ	CMP_INV_OUT	0	CMP_FLT_OFF	CMP_EN	
rh			r				rw	r	rw	rw	rw	r	rw	rw	

Field	Bits	Type	Description
<b>CMP_EN</b>	0	rw	<b>Comparator enable</b> 0B <b>CMP_EN</b> , Comparator is disabled 1B <b>CMP_DIS</b> , Comparator is enabled
<b>CMP_FLT_OFF</b>	1	rw	<b>Disables comparator filter</b> If set, the comparator glitch-filter is switched off 0B <b>FIL_ON</b> , filter is active 1B <b>FIL_OFF</b> , filter is switched off (to prevent a filter delay)
<b>CMP_INV_OUT</b>	3	rw	<b>Inverted Comparator output</b> The comparator output is simply inverted 0B <b>INV_OFF</b> , no inversion of comparator signal 1B <b>INV_ON</b> , comparator signal is inverted
<b>CMP_HYST_ADJ</b>	5:4	rw	<b>Comparator hysteresis adjust</b> To reduce noise sensitivity a hysteresis voltage can be chosen. It can be switched off with writing 00B <b>HYS_OFF</b> , Comparator hysteresis is switched off 01B <b>HYS1</b> , Hysteresis_typ = 10mV 10B <b>HYS2</b> , Hysteresis_typ = 15mV 11B <b>HYS3</b> , Hysteresis_typ = 20mV

**Analog Comparator (ACMP) and Out of Range Comparator**

Field	Bits	Type	Description
<b>ACMP0_SEL</b>	6	rw	<b>Connect ACMP0.INP to ACMP1.INP</b> An internal switch connects comparator pad ACMP0.INP with pad ACMP1.INP together. Only one of both input pad shall be driven by a voltage source. The time delay between both pads is caused by the impedance of the switch. When bit ANACMP1.REF_DIV_EN is set, the divided reference voltage is applied not only to ACMP1.INP, but also to ACMP0.INP 0B <b>OFF</b> , ACMP0.INP is not connected 1B <b>ON</b> , ACMP0.INP is connected to ACMP1.INP
<b>CMP_LPWR</b>	8	rw	<b>Low Power Mode</b> If enabled, all three analog comparator units are set into low power mode. If the logic level of this bit is changed, the core has to blank the comparator output information a certain time. 0B <b>HPM</b> , High Power Mode 1B <b>LPM</b> , Low Power Mode
<b>CMP_OUT</b>	15	rh	<b>Comparator output monitor bit</b> This bit corresponds to the comparator output status 0B <b>OUT0</b> , state "Vminus > Vplus" 1B <b>OUT1</b> , state "Vminus < Vplus"
<b>0</b>	2, 7, 14:9	r	<b>Reserved</b> Read as 0; should be written with 0.

**ANACMP1**

Analog Comparator 1 Control Register

**ANACMP1**

Analog Comparator 1 Control Register(1060<sub>H</sub>)

Reset Value: 0020<sub>H</sub>

15	14	13	12	11	10	9	8	7	6	5	4	3	2	1	0
<b>CMP_OUT</b>				<b>0</b>					<b>REF_DIV_EN</b>	<b>CMP_HYS_T_ADJ</b>	<b>CMP_INV_OUT</b>	<b>0</b>	<b>CMP_FLT_OF</b>	<b>CMP_EN</b>	
rh				r					rw	rw	rw	r	rw	rw	

**Analog Comparator (ACMP) and Out of Range Comparator**

Field	Bits	Type	Description
<b>CMP_EN</b>	0	rw	<b>Comparator enable</b> 0B <b>CMP_EN</b> , Comparator is disabled 1B <b>CMP_DIS</b> , Comparator is enabled
<b>CMP_FLT_OFF</b>	1	rw	<b>Disables comparator filter</b> If set, the comparator glitch-filter is switched off 0B <b>FIL_ON</b> , filter is active 1B <b>FIL_OFF</b> , filter is switched off (to prevent a filter delay)
<b>CMP_INV_OUT</b>	3	rw	<b>Inverted Comparator output</b> The comparator output is simply inverted 0B <b>INV_OFF</b> , no inversion of comparator signal 1B <b>INV_ON</b> , comparator signal is inverted
<b>CMP_HYST_ADJ</b>	5:4	rw	<b>Comparator hysteresis adjust</b> To reduce noise sensitivity a hysteresis voltage can be chosen. It can be switched off with writing 00B <b>HYS_OFF</b> , Comparator hysteresis is switched off 01B <b>HYS1</b> , Hysteresis_typ = 10mV 10B <b>HYS2</b> , Hysteresis_typ = 15mV 11B <b>HYS3</b> , Hysteresis_typ = 20mV
<b>REF_DIV_EN</b>	6	rw	<b>Resistor Divider is enabled and Reference Voltage is applied to ACMP1</b> The divider reference voltage is applied to the positive ACMP1 input 0B <b>OFF</b> , no resistor is connected 1B <b>ON</b> , the divider resistor is enabled and the voltage is applied to ACMP1.INP
<b>CMP_OUT</b>	15	rh	<b>Comparator output monitor bit</b> This bit corresponds to the comparator output status 0B <b>OUT0</b> , state "Vminus > Vplus" 1B <b>OUT1</b> , state "Vminus < Vplus"
<b>0</b>	2, 14:7	r	<b>Reserved</b> Read as 0; should be written with 0.

**Analog Comparator (ACMP) and Out of Range Comparator**

**ANACMP2**

Analog Comparator 2 Control Register

**ANACMP2**

**Analog Comparator 2 Control Register(1064<sub>H</sub>)**

**Reset Value: 0020<sub>H</sub>**

15	14	13	12	11	10	9	8	7	6	5	4	3	2	1	0
<b>CMP_OUT</b>					0				<b>ACMP2_SEL</b>	<b>CMP_HYST_ADJ</b>	<b>CMP_INV_OUT</b>	0	<b>CMP_FLT_OFF</b>	<b>CMP_EN</b>	
rw				r					rw	rw	rw	r	rw	rw	

Field	Bits	Type	Description
<b>CMP_EN</b>	0	rw	<b>Comparator enable</b> 0B <b>CMP_EN</b> , Comparator is disabled 1B <b>CMP_DIS</b> , Comparator is enabled
<b>CMP_FLT_OFF</b>	1	rw	<b>Disables comparator filter</b> If set, the comparator glitch-filter is switched off 0B <b>FIL_ON</b> , filter is active 1B <b>FIL_OFF</b> , filter is switched off (to prevent a filter delay)
<b>CMP_INV_OUT</b>	3	rw	<b>Inverted Comparator output</b> The comparator output is simply inverted 0B <b>INV_OFF</b> , no inversion of comparator signal 1B <b>INV_ON</b> , comparator signal is inverted
<b>CMP_HYST_ADJ</b>	5:4	rw	<b>Comparator hysteresis adjust</b> To reduce noise sensitivity a hysteresis voltage can be chosen. It can be switched off with writing 00B <b>HYS_OFF</b> , Comparator hysteresis is switched off 01B <b>HYS1</b> , Hysteresis_typ = 10mV 10B <b>HYS2</b> , Hysteresis_typ = 15mV 11B <b>HYS3</b> , Hysteresis_typ = 20mV



**Analog Comparator (ACMP) and Out of Range Comparator**

Field	Bits	Type	Description
<b>ACMP2_SEL</b>	6	rw	<p><b>Connect ACMP2.INP to ACMP1.INP</b></p> <p>An internal switch connects comparator pad ACMP2.INP with pad ACMP1.INP together. Only one of both input pad shall be driven by a voltage source. The time delay between both pads is caused by the impedance of the switch. When bit ANACMP1.REF_DIV_EN is set, the divided reference voltage is applied not only to ACMP1.INP, but also to ACMP2.INP</p> <p>0B <b>OFF</b>, ACMP2.INP is not connected 1B <b>ON</b>, ACMP2.INP is connected to ACMP1.INP</p>
<b>CMP_OUT</b>	15	rh	<p><b>Comparator output monitor bit</b></p> <p>This bit corresponds to the comparator output status</p> <p>0B <b>OUT0</b>, state "Vminus &gt; Vplus" 1B <b>OUT1</b>, state "Vminus &lt; Vplus"</p>
<b>0</b>	2, 14:7	r	<p><b>Reserved</b></p> <p>Read as 0; should be written with 0.</p>

**Analog Comparator (ACMP) and Out of Range Comparator**

**17.7 Interconnects**

ACMP and ORC are connected to the ports, the ERU0 and BCCU0.

**Table 17-3 Analog Comparator Pin Connections**

<b>Input/Output</b>	<b>I/O</b>	<b>Connected To</b>	<b>Description</b>
ACMP0.INN	I	P2.8	"-" input of ACMP0
ACMP0.INP	I	P2.9	"+" input of ACMP0
ACMP1.INN	I	P2.6	"-" input of ACMP1
ACMP1.INP	I	P2.7	"+" input of ACMP1
ACMP2.INN	I	P2.2	"-" input of ACMP2
ACMP2.INP	I	P2.1	"+" input of ACMP2
ACMP.REF	I	P2.11	Reference input of ACMP
ACMP0.OUT	O	P0.10 P2.10 ERU0.0A0 BCCU0.IN5	output of ACMP0
ACMP1.OUT	O	P1.0 ERU0.1A0 BCCU0.IN0 P2.5.HW0 pull control	output of ACMP1
ACMP2.OUT	O	P0.5 P1.2 ERU0.2A0 BCCU0.IN3 P2.3.HW0 pull control	output of ACMP2

**Table 17-4 Out of Range Comparator Pin Connections**

<b>Input/Output</b>	<b>I/O</b>	<b>Connected To</b>	<b>Description</b>
ORC0.AIN	I	P2.2	analog input of ORC0
ORC1.AIN	I	P2.3	analog input of ORC1
ORC2.AIN	I	P2.4	analog input of ORC2
ORC3.AIN	I	P2.5	analog input of ORC3
ORC4.AIN	I	P2.6	analog input of ORC4
ORC5.AIN	I	P2.7	analog input of ORC5
ORC6.AIN	I	P2.8	analog input of ORC6

**Analog Comparator (ACMP) and Out of Range Comparator**

**Table 17-4 Out of Range Comparator Pin Connections (cont'd)**

<b>Input/Output</b>	<b>I/O</b>	<b>Connected To</b>	<b>Description</b>
ORC7.AIN	I	P2.9	analog input of ORC7
ORC0.OUT	O	ERU0.0B2	output of ORC0
ORC1.OUT	O	ERU0.1B2	output of ORC1
ORC2.OUT	O	ERU0.0A2 ERU0.2B2	output of ORC2
ORC3.OUT	O	ERU0.1A2	output of ORC3
ORC4.OUT	O	ERU0.2A2	output of ORC4
ORC5.OUT	O	ERU0.3A2	output of ORC5
ORC6.OUT	O	ERU0.3B2	output of ORC6
ORC7.OUT	O	ERU0.3A0	output of ORC7

## 18 Temperature Sensor (TSE)

This chapter describes the controls for Temperature Sensor (TSE).

### 18.1 General Description

The Temperature Sensor (TSE) generates a measurement result that indicates directly the current temperature. The result of the measurement is displayed via bit field ANATSEMON.TSE\_MON. User can take this value to calculate the actual silicon temperature using a formulae (defined in the target electrical parameter chapter). The DTS has to be enabled before it can be used via bit ANATSECTRL.TSE\_EN.

The measurement result is ready when the SRRAW.TSE\_DONE flag is set. An interrupt can be triggered when it is enabled via SRMSK.TSE\_DONE bit. After the measurement is completed and result is stored in TSE\_MON, TSE continue with next measurement. Measurement are disabled when TSE\_EN is cleared to 0. Hence, reading the TSE\_MON value will provide you the latest temperature.

The TSE is capable of generating interrupt requests when TSE temperature measurement in result crosses upper and/or lower threshold value configured in bit ANATSEIH.TSE\_IH and ANATSEIL.TSE\_IL respectively. Digital comparators are implemented to compare the actual measurement result against configured limits and triggers interrupt if the value fall outside of valid range. Result of comparison is shown as the SRRAW.TSE\_HIGH and TSE\_LOW flag. Formulae to calculate the upper and lower temperature limits are defined in the Data Sheet.

There are 3 constants: k1 (16 bits), k2 (32 bits), k3 (16bits), in the formulae and these values are stored in flash configuration page.

### 18.2 Service Request Generation

The TSE has a service request output for TSE Done, TSE HIGH and TSE Low event. They are combined with events from other modules into a single output and connected to one of the interrupt node in the Nested Vectored Interrupt Controller (NVIC) via SCU.SR1.

The service request handling is part of the GCU block in SCU module. Refer to the “Service Request” description in the GCU section which is part of the SCU chapter for more details.

### 18.3 Registers

TSE registers are accessible via the APB bus. The absolute register address is calculated by adding:

Module Base Address + Offset Address

Following access to TSE SFRs result in an AHB/APB error response:

**Temperature Sensor (TSE)**

- Read or write access to undefined address
- Write access to read-only registers

**Table 18-1 Registers Address Space**

Module	Base Address	End Address	Note
TSE	4001 0000 <sub>H</sub>	4001 FFFF <sub>H</sub>	System Control Unit Registers

**Table 18-2 Registers Overview**

Short Name	Description	Offset Addr. <sup>1)</sup>	Access Mode		Description See
			Read	Write	
ANATSECTRL	Temperature Sensor Control Register	0024 <sub>H</sub>	U, PV	U, PV	<a href="#">Page 18-2</a>
ANATSEIH	Temperature Sensor High Interrupt Register	0030 <sub>H</sub>	U, PV	U, PV	<a href="#">Page 18-3</a>
ANATSEIL	Temperature Sensor Low Interrupt Register	0034 <sub>H</sub>	U, PV	U, PV	<a href="#">Page 18-4</a>
ANATSEMON	Temperature Sensor Counter2 Monitor Register	0040 <sub>H</sub>	U, PV	U, PV	<a href="#">Page 18-4</a>

1) The absolute register address is calculated as follows:  
Module Base Address + Offset Address (shown in this column)

### 18.3.1 Registers

#### ANATSECTRL

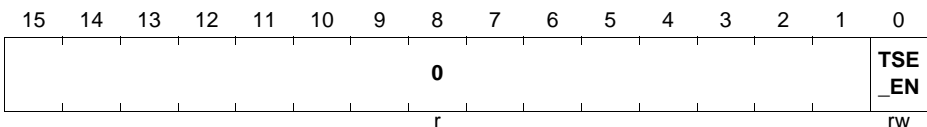
Temperature Sensor Control Register

#### ANATSECTRL

Temperature Sensor Control Register

(1024<sub>H</sub>)

Reset Value: 0000<sub>H</sub>



**Temperature Sensor (TSE)**

Field	Bits	Type	Description
<b>TSE_EN</b>	0	rw	<b>Temperature sensor enable</b> 0B Temperature sensor is disabled 1B Temperature sensor is switched on
<b>0</b>	15:1	r	<b>Reserved</b> Read as 0; should be written with 0.

**ANATSEIH**

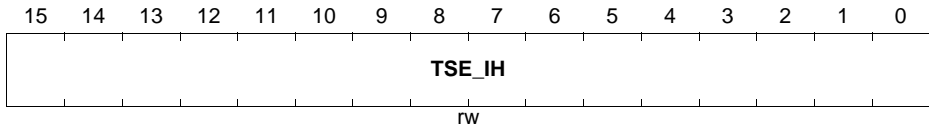
Temperature Sensor High Temperature Interrupt Register

**ANATSEIH**

Temperature Sensor High Temperature Interrupt Register

(1030<sub>H</sub>)

Reset Value: 0000<sub>H</sub>



Field	Bits	Type	Description
<b>TSE_IH</b>	15:0	rw	<b>Counter value for high temperature interrupt</b> ANATSEIH value is compared with ANATSEMON (with the counter value) An high temperature interrupt is triggered if: ANATSE_MON < ANATSEIH  The comparison result can be observed from SCU_SRRAW.TSE_HIGH

**ANATSEIL**

Temperature Sensor Low Temperature Interrupt Register

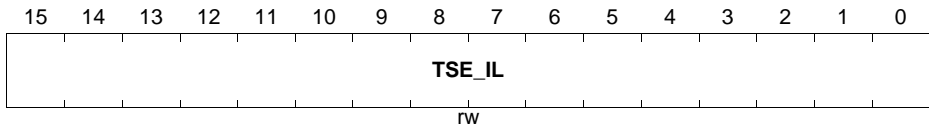
**Temperature Sensor (TSE)**

**ANATSEIL**

Temperature Sensor Low Temperature Interrupt Register

(1034<sub>H</sub>)

Reset Value: FFFF<sub>H</sub>



Field	Bits	Type	Description
TSE_IL	15:0	rw	<p><b>Counter value for low temperature interrupt</b> ANATSEIL value is compared with ANATSEMON An low interrupt is triggered if: ANATSEMON &gt; ANATSEIL</p> <p>The comparison result can be observed from SCU_SRRAW.TSE_LOW</p>

**ANATSEMON**

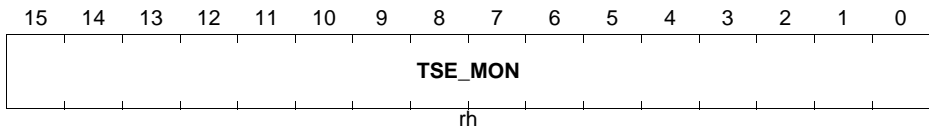
Temperature Sensor Counter2 Monitor Register

**ANATSEMON**

Temperature Sensor Counter2 Monitor Register

(1040<sub>H</sub>)

Reset Value: 0000<sub>H</sub>



Field	Bits	Type	Description
TSE_MON	15:0	rh	<p><b>Monitor Counter2 value; loaded by TSE_DONE</b> After each measurement done event (indicated by a set in SCU_SRRAW.TSE_DONE bit), the result is stored in this register.</p>

# **Industrial Control Peripherals**



## 19 Capture/Compare Unit 4 (CCU4)

The CCU4 peripheral is a major component for systems that need general purpose timers for signal monitoring/conditioning and Pulse Width Modulation (PWM) signal generation. Power electronic control systems like switched mode power supplies or uninterruptible power supplies, can easily be implemented with the functions inside the CCU4 peripheral.

The internal modularity of CCU4, translates into a software friendly system for fast code development and portability between applications.

**Table 19-1 Abbreviations table**

PWM	Pulse Width Modulation
CCU4x	Capture/Compare Unit 4 module instance x
CC4y	Capture/Compare Unit 4 Timer Slice instance y
ADC	Analog to Digital Converter
POSIF	Position Interface peripheral
SCU	System Control Unit
$f_{ccu4}$	CCU4 module clock frequency
$f_{tclk}$	CC4y timer clock frequency

*Note: A small “y” or “x” letter in a register indicates an index*

### 19.1 Overview

Each CCU4 module is comprised of four identical 16 bit Capture/Compare Timer slices, CC4y. Each timer slice can work in compare mode or in capture mode. In compare mode one compare channel is available while in capture mode, up to four capture registers can be used in parallel.

Each CCU4 module has four service request lines and each timer slice contains a dedicated output signal, enabling the generation of up to four independent PWM signals. Straightforward timer slice concatenation is also possible, enabling up to 64 bit timing operations. This offers a flexible frequency measurement, frequency multiplication and pulse width modulation scheme.

A programmable function input selector for each timer slice, that offers up to nine functions, discards the need of complete resource mapping due to input ports availability.

A built-in link between the CCU4 and several other modules enable flexible digital motor control loops implementation, e.g. with Hall Sensor monitoring or direct coupling with Encoders.

## 19.1.1 Features

### CCU4 module features

Each CCU4 represents a combination of four timer slices, that can work independently in compare or capture mode. Each timer slice has a dedicated output for PWM signal generation.

All four CCU4 timer slices, CC4y, are identical in terms of available functions and operating modes. Avoiding this way the need of implementing different software routines, depending on which resource of CCU4 is used.

A built-in link between the four timer slices is also available, enabling this way a simplified timer concatenation and sequential operations.

#### General Features

- 16 bit timer cells
- capture and compare mode for each timer slice
  - four capture registers in capture mode
  - one compare channel in compare mode
- programmable low pass filter for the inputs
- built-in timer concatenation
  - 32, 48 or 64 bit width
- shadow transfer for the period and compare values
- programmable clock prescaler
- normal timer mode
- gated timer mode
- three counting schemes
  - center aligned
  - edge aligned
  - single shot
- PWM generation
- TRAP function
- start/stop can be controlled by external events
- counting external events
- four dedicated service request lines per CCU4

#### Additional features

- external modulation function
- load controlled by external events
- dithering PWM
- floating point pre scaler
- output state override by an external event
- suitable and flexible connectivity to several modules:
  - motor and power conversion applications
  - high number of signal conditioning possibilities

**CCU4 features vs. applications**

On [Table 19-2](#) a summary of the major features of the CCU4 unit mapped with the most common applications.

**Table 19-2 Applications summary**

<b>Feature</b>	<b>Applications</b>
Four independent timer cells	Independent PWM generation: <ul style="list-style-type: none"> <li>• Multiple buck/boost converter control (with independent frequencies)</li> <li>• Different modes of operation for each timer, increasing the resource optimization</li> <li>• Up to 2 Half-Bridges control</li> <li>• multiple Zero Voltage Switch (ZVS) converter control with easy link to the ADC channels.</li> </ul>
Concatenated timer cells	Easy to configure timer extension up to 64 bit: <ul style="list-style-type: none"> <li>• High dynamic trigger capturing</li> <li>• High dynamic signal measurement</li> </ul>
Dithering PWM	Generating a fractional PWM frequency or duty cycle: <ul style="list-style-type: none"> <li>• To avoid big steps on frequency or duty cycle adjustment in slow control loop applications</li> <li>• Increase the PWM signal resolution over time</li> </ul>
Floating prescaler	Automated control signal measurement: <ul style="list-style-type: none"> <li>• decrease SW activity for monitoring signals with high or unknown dynamics</li> <li>• emulating more than a 16 bit timer for system control</li> </ul>
Up to 9 functions via external signals for each timer	Flexible resource optimization: <ul style="list-style-type: none"> <li>• The complete set of external functions is always available</li> <li>• Several arrangements can be done inside a CCU4, e.g., one timer working in capture mode and one working in compare</li> </ul>

**Table 19-2 Applications summary (cont'd)**

Feature	Applications
4 dedicated service request lines	Specially developed for: <ul style="list-style-type: none"> <li>• generating interrupts for the microprocessor</li> <li>• flexible connectivity between peripherals, e.g. ADC triggering.</li> </ul>
Linking with other modules	Flexible profiles for: <ul style="list-style-type: none"> <li>• Hall Sensor feedback/monitoring</li> <li>• Motor Encoders feedback/monitoring</li> <li>• PWM parallel modulation</li> <li>• Flexible signal conditioning</li> </ul>

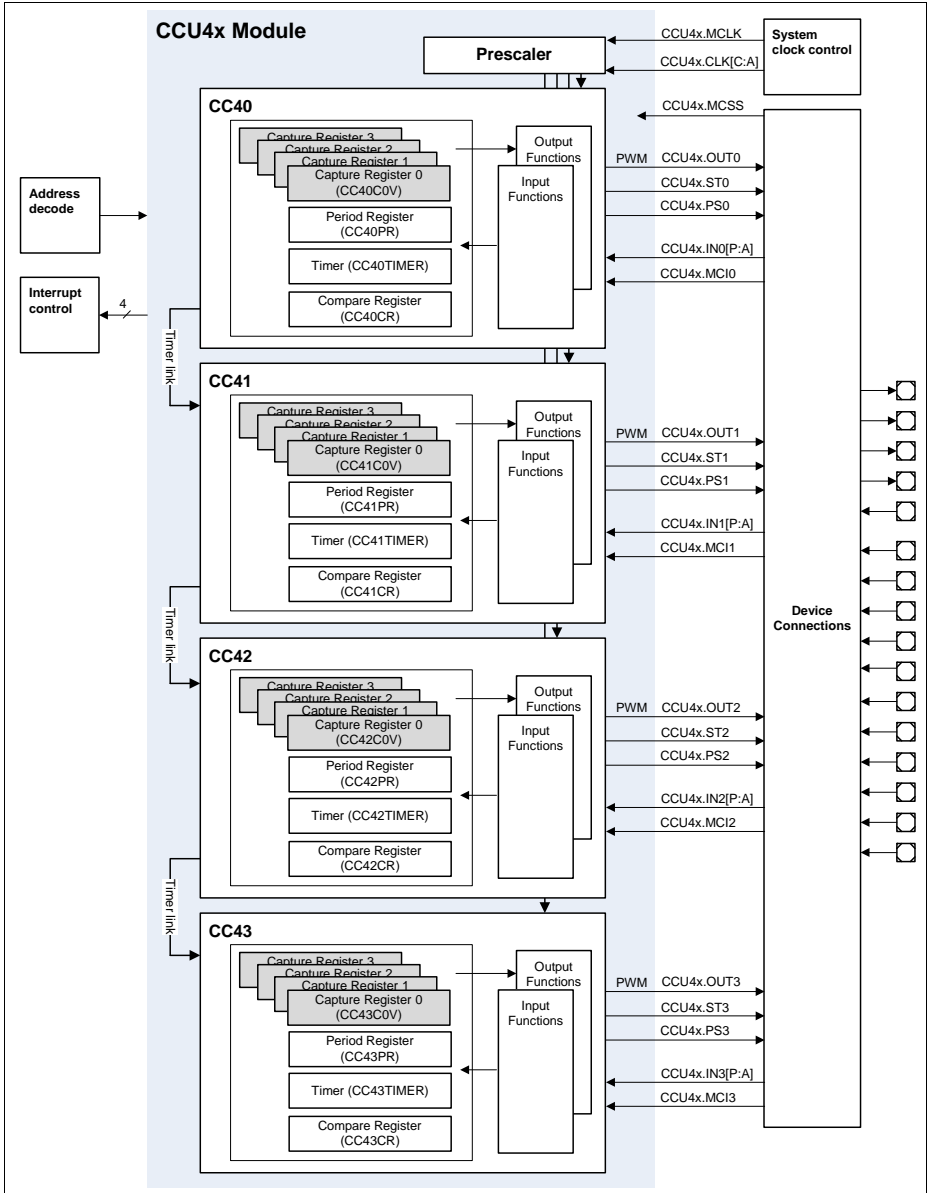
### 19.1.2 Block Diagram

Each CCU4 timer slice can operate independently from the other slices for all the available modes. Each timer slice contains a dedicated input selector for functions linked with external events and has a dedicated compare output signal, for PWM signal generation.

The built-in timer concatenation is only possible with adjacent slices, e.g. CC40/CC41. Combinations for slice concatenations like, CC40/CC42 or CC40/CC43 are not possible.

The individual service requests for each timer slice (four per slice) are multiplexed into four module service requests lines, [Figure 19-1](#).

**Capture/Compare Unit 4 (CCU4)**



**Figure 19-1 CCU4 block diagram**

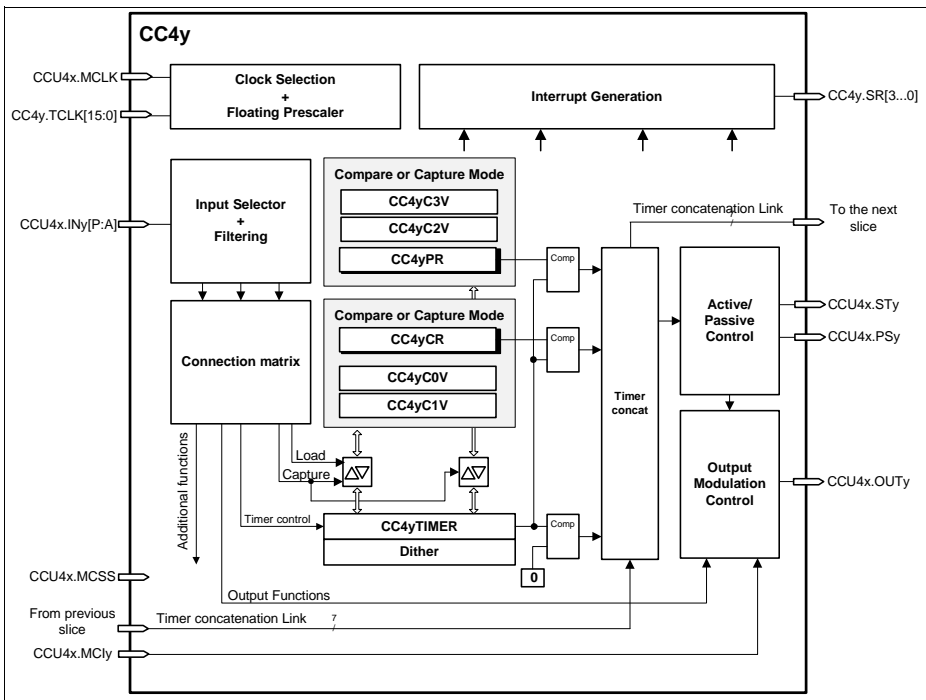
## 19.2 Functional Description

### 19.2.1 CC4y Overview

The input path of a CCU4 slice is comprised of a selector ([Section 19.2.2](#)) and a connection matrix unit ([Section 19.2.3](#)). The output path contains a service request control unit, a timer concatenation unit and two units that control directly the state of the output signal for each specific slice (for TRAP and modulation handling), see [Figure 19-2](#).

The timer core is built of a 16 bit counter one period and one compare register in capture mode, or up to four capture registers in capture mode.

In compare mode the period register sets the maximum counting value while the compare channel is controlling the ACTIVE/PASSIVE state of the dedicated comparison slice output.



**Figure 19-2 CCU4 slice block diagram**

**Capture/Compare Unit 4 (CCU4)**

Each CCU4 slice, with the exception of the first, contains six dedicated inputs outputs that are used for the built-in timer concatenation functionality.

Inputs and outputs that are not seen at the CCU4 boundaries have a nomenclature of CC4y.<name>, whilst CCU4 module inputs and outputs are described as CCU4x.<signal\_name>y (indicating the variable y the object slice).

**Table 19-3 CCU4 slice pin description**

Pin	I/O	Description
CCU4x.MCLK	I	Module clock
CC4y.TCLK[15:0]	I	Clocks from the pre scaler
CCU4x.INy[P:A]	I	Slice functional inputs (used to control the functionality throughout slice external events)
CCU4x.MCIy	I	Multi Channel mode input
CCU4x.MCSS	I	Multi Channel shadow transfer trigger
CC4y.SR[3...0]	O	Slice service request lines
CC4x.STy	O	Slice comparison status value
CCU4x.PSy	O	Multi channel pattern update trigger
CCU4x.OUTy	O	Slice dedicated output pin

*Note:*

4. *The status bit outputs of the Kernel, CCU4x.STy, are extended for one more kernel clock cycle.*
5. *The Service Request signals at the output of the kernel are extended for one more kernel clock cycle.*
6. *The maximum output signal frequency of the CCU4x.STy outputs is module clock divided by 4.*

The slice timer, can count up or down depending on the selected operating mode. A direction flag holds the actual counting direction.

The timer is connected to two stand alone comparators, one for the period match and one for a compare match. The registers used for period match and comparison match can be programmed to serve as capture registers enabling sequential capture capabilities on external events.

In normal edge aligned counting scheme, the counter is cleared to 0000<sub>H</sub> each time that matches the period value defined in the period register. In center aligned mode, the counter direction changes from 'up counting' to 'down counting' after reaching the period

---

## **Capture/Compare Unit 4 (CCU4)**

value. Both period and compare registers have an aggregated shadow register, which enables the update of the PWM period and duty cycle on the fly.

A single shot mode is also available, where the counter stops after it reaches the value set in the period register.

The start and stop of the counter can be controlled via software access or by a programmable input pin.

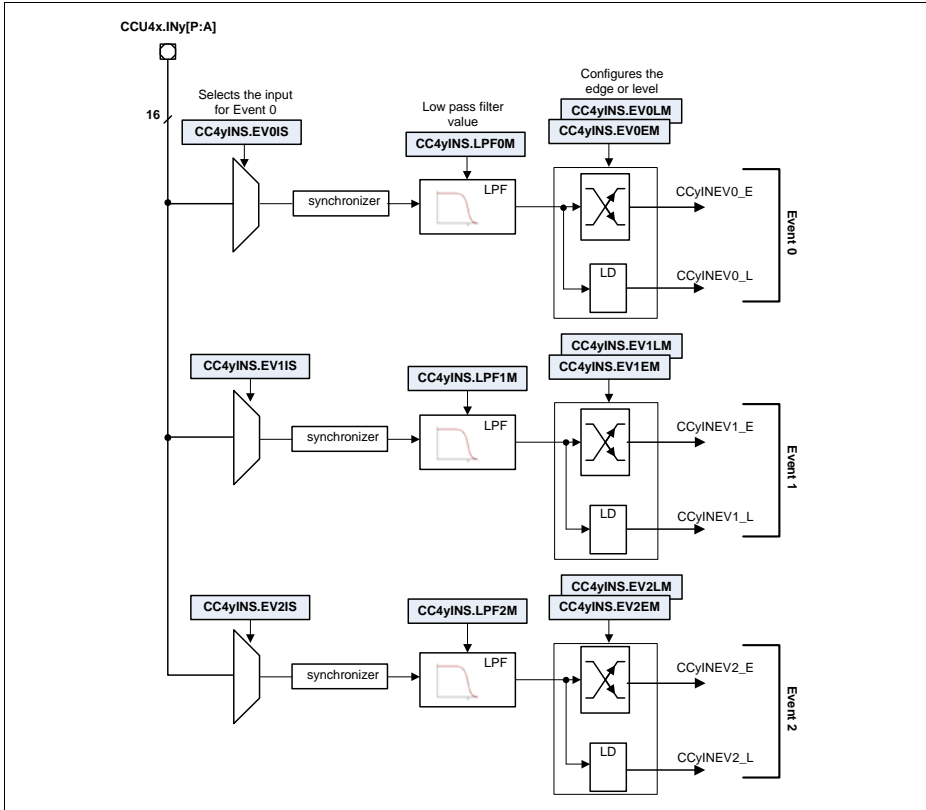
Functions like, load, counting direction (up/down), TRAP and output modulation can also be controlled with external events, see [Section 19.2.3](#).

### **19.2.2 Input Selector**

The first unit of the slice input path, is used to select which inputs are used to control the available external functions.

Inside this block the user also has the possibility to perform a low pass filtering of the signals and selecting the active edge(s) or level of the external event, see [Figure 19-3](#).





**Figure 19-3 Slice input selector diagram**

The user has the possibility of selecting any of the CCU4x.INy[P:A] inputs as the source of an event.

At the output of this unit we have a user selection of three events, that were configured to be active at rising, falling or both edges, or level active. These selected events can then be mapped to several functions.

Notice that each decoded event contains two outputs, one edge active and one level active, due to the fact that some functions like counting, capture or load are edge sensitive events while, timer gating or up down counting selection are level active.

### 19.2.3 Connection Matrix

The connection matrix maps the events coming from the input selector to several user configured functions, [Figure 19-4](#). The following functions can be enabled on the connection matrix:

**Table 19-4 Connection matrix available functions**

Function	Brief description	Map to figure <a href="#">Figure 19-4</a>
Start	Edge signal to start the timer	CCystrt
Stop	Edge signal to stop the timer	CCystp
Count	Edge signal used for counting events	CCycnt
Up/down	Level signal used to select up or down counting direction	CCyupd
Capture 0	Edge signal that triggers a capture into the capture registers 0 and 1	CCycapt0
Capture 1	Edge signal that triggers a capture into the capture register 2 and 3	CCycapt1
Gate	Level signal used to gate the timer clock	CCygate
Load	Edge signal that loads the timer with the value present at the compare register	CCyload
TRAP	Level signal used for fail-safe operation	CCytrap
Modulation	Level signal used to modulate/clear the output	CCymod
Status bit override	Status bit is going to be overridden with an input value	CCyoval for the value CCyoset for the trigger

Inside the connection matrix we also have a unit that performs the built-in timer concatenation. This concatenation enables a completely synchronized operation between the concatenated slices for timing operations and also for capture and load actions. The timer slice concatenation is done via the **CC4yCMC.TCE** bitfield. For a complete description of the concatenation function, please address [Section 19.2.9](#).

Capture/Compare Unit 4 (CCU4)

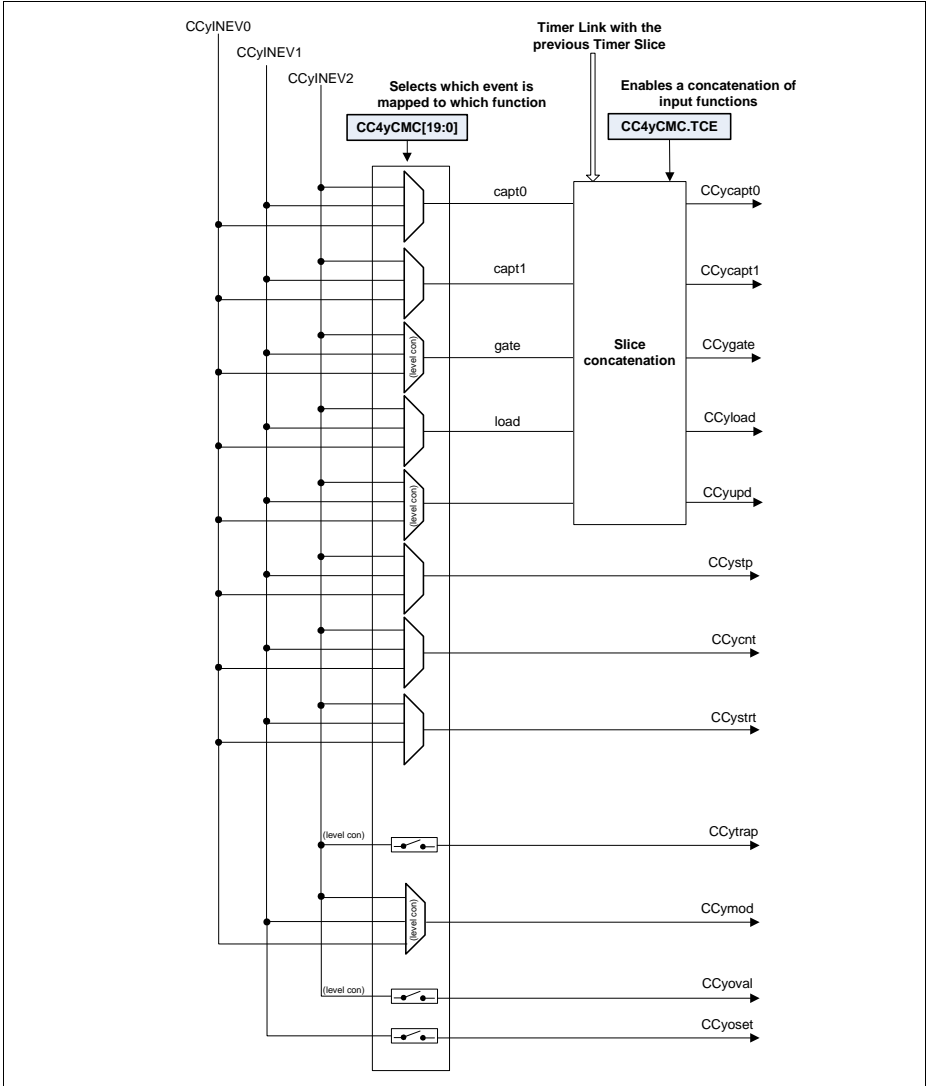


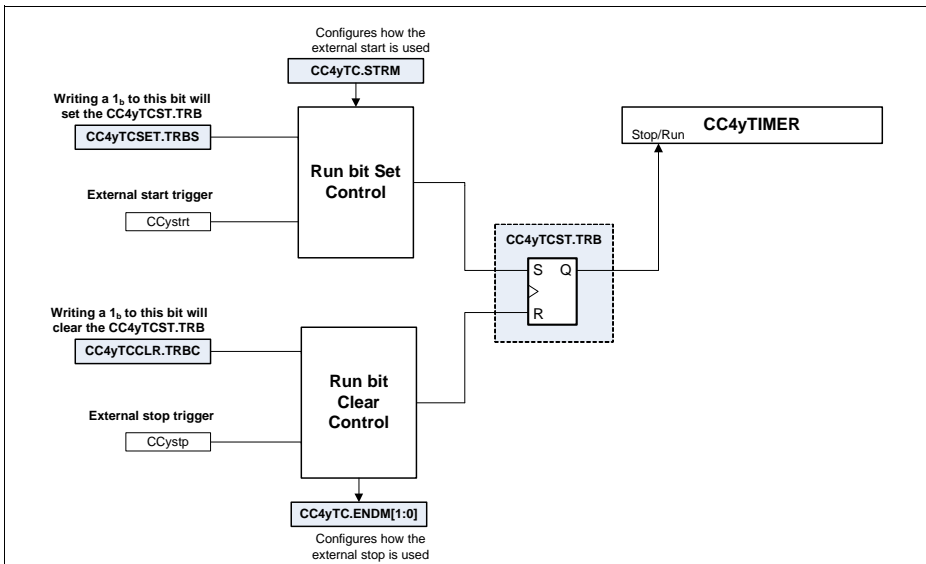
Figure 19-4 Slice connection matrix diagram

### 19.2.4 Starting/Stopping the Timer

Each timer slice contains a run bit register that indicates the actual status of the timer, **CC4yTCST.TRB**. The start and stop of the timer can be done via software access or can be controlled directly by external events, see **Figure 19-5**.

Selecting an external signal that acts as a start trigger does not force the user to use an external stop trigger and vice versa.

Selecting the single shot mode, imposes that after the counter reaches the period value the run bit, **CC4yTCST.TRB**, is going to be cleared and therefore the timer is stopped.



**Figure 19-5** Timer start/stop control diagram

One can use the external stop signal to perform the following functions (configuration via **CC4yTC.ENDM**):

- Clear the run bit (stops the timer) - default
- Clear the timer (to 0000<sub>H</sub>) but it does not clear the run bit (timer still running)
- Clear the timer and the run bit

One can use the external start to perform the following functions (configuration via **CC4yTC.STRM**):

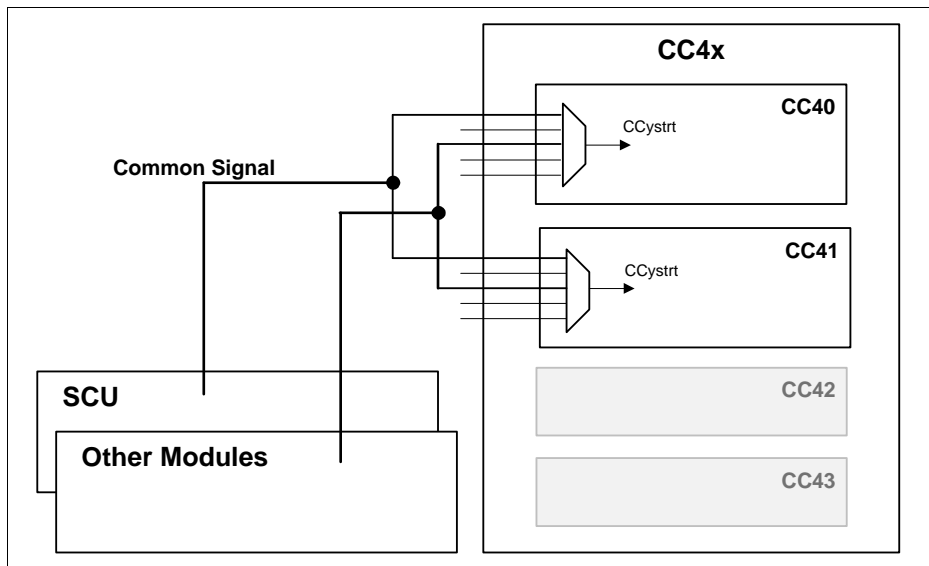
- Start the timer (resume operation)
- Clear and start the timer

The set (start the timer) of the timer run bit, always has priority over a clear (stop the timer).

**Capture/Compare Unit 4 (CCU4)**

To start multiple CCU4 timers at the same time/synchronously one should use a dedicated input as external start (see [Section 19.2.7.1](#) for a description how to configure an input as start function). This input should be connected to all the Timers that need to be started synchronously (see [Section 19.8](#) for a complete list of module connections), [Figure 19-6](#).

For starting the timers synchronously via software there is a dedicated input signal, controlled by the SCU (System Control Unit), that is connected to all the CCU4 timers. This signal should then be configured as an external start signal (see [Section 19.2.7.1](#)) and then the software must write a 1<sub>B</sub> to the specific bitfield of the CCUCON register (this register is described on the SCU chapter).



**Figure 19-6 Starting multiple timers synchronously**

### 19.2.5 Counting Modes

Each CC4y timer slice can be programmed into three different counting schemes:

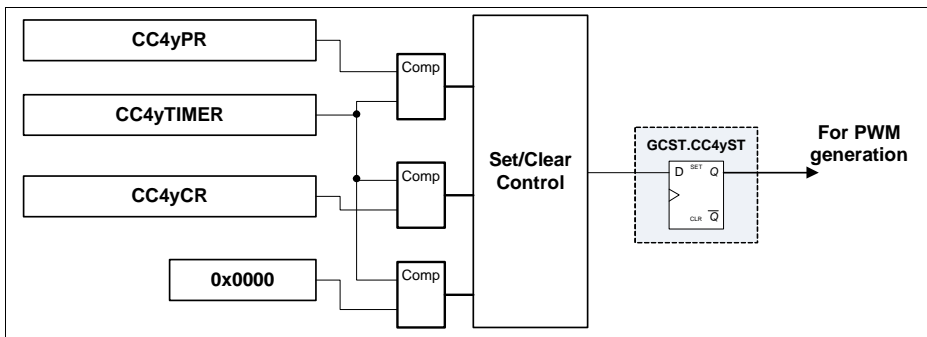
- Edge aligned (default)
- Center aligned
- Single shot (can be edge or center aligned)

These three counting schemes can be used as stand alone without the need of selecting any inputs as external event sources. Nevertheless it is also possible to control the counting operation via external events like, timer gating, counting trigger, external stop, external start, etc.

**Capture/Compare Unit 4 (CCU4)**

For all the counting modes, it is possible to update on the fly the values for the timer period and compare channel. This enables a cycle by cycle update of the PWM frequency and duty cycle.

The compare channel of each CC4y Timer Slice, has an associated Status Bit (**GCST.CC4yST**), that indicates the active or passive state of the channel, **Figure 19-7**. The set and clear of the status bit and the respective PWM signal generation is dictated by the timer period, compare value and the current counting mode. See the different counting mode descriptions, **Section 19.2.5.3** to **Section 19.2.5.5** to understand how this bit is set and cleared.



**Figure 19-7 CC4y Status Bit**

**19.2.5.1 Calculating the PWM Period and Duty Cycle**

The period of the timer is determined by the value in the period register, **CC4yPR** and by the timer mode.

The base for the PWM signal frequency and duty cycle, is always related to the clock frequency of the timer itself and not to the frequency of the module clock (due to the fact that the timer clock can be a scaled version of the module clock).

In Edge Aligned Mode, the timer period is:

$$T_{per} = \langle \text{Period-Value} \rangle + 1; \text{ in } f_{tclk} \tag{19.1}$$

In Center Aligned Mode, the timer period is:

$$T_{per} = (\langle \text{Period-Value} \rangle + 1) \times 2; \text{ in } f_{tclk} \tag{19.2}$$

For each of these counting schemes, the duty cycle of generated PWM signal is dictated by the value programmed into the **CC4yCR** register.

In Edge Aligned and Center Aligned Mode, the PWM duty cycle is:

$$DC = 1 - \langle \text{Compare-Value} \rangle / (\langle \text{Period-Value} \rangle + 1) \tag{19.3}$$

---

## Capture/Compare Unit 4 (CCU4)

Both **CC4yPR** and **CC4yCR** can be updated on the fly via software, enabling a glitch free transition between different period and duty cycle values for the generated PWM signal, [Section 19.2.5.2](#)

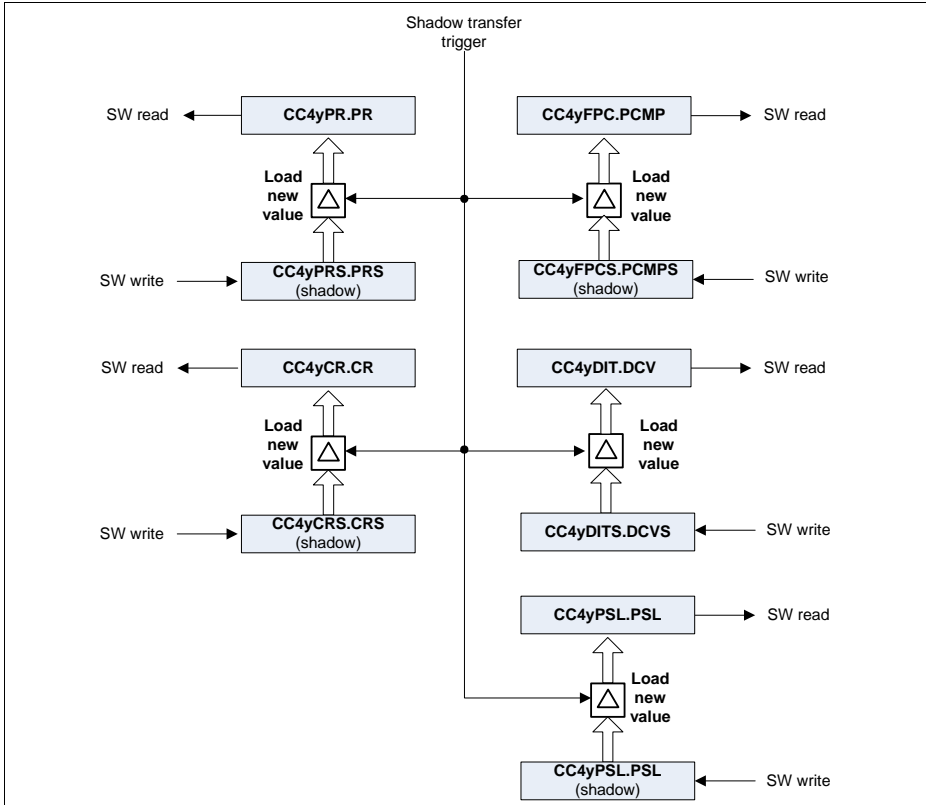
### 19.2.5.2 Updating the Period and Duty Cycle

Each CCU4 timer slice provides an associated shadow register for the period and compare values. This facilitates a concurrent update by software for these two parameters, with the objective of modifying during run time the PWM signal period and duty cycle.

In addition to the shadow registers for the period and compare values, one also has available shadow registers for the floating prescaler and dither functions, **CC4yFPCS** and **CC4yDITS** respectively (please address [Section 19.2.11](#) and [Section 19.2.10](#) for a complete description of these functions).

The structure of the shadow registers can be seen in [Figure 19-8](#).

Capture/Compare Unit 4 (CCU4)



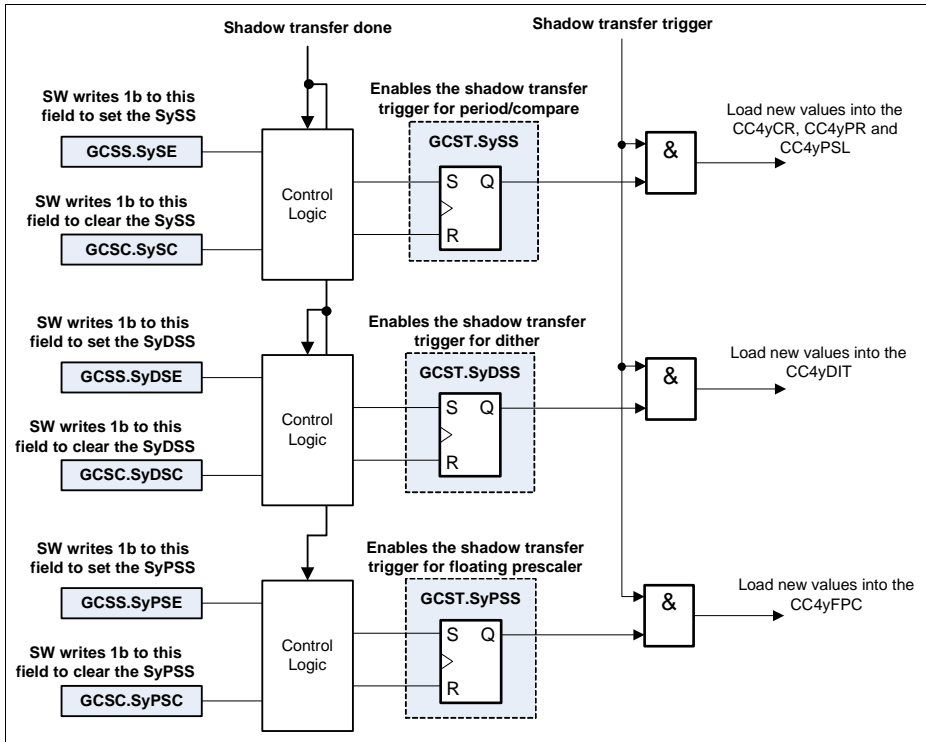
**Figure 19-8 Shadow registers overview**

The update of these registers can only be done by writing a new value into the associated shadow register and wait for a shadow transfer to occur.

Each group of shadow registers have an individual shadow transfer enable bit, [Figure 19-9](#). The software must set this enable bit to 1<sub>B</sub>, whenever an update of the values is needed. These bits are automatically cleared by the hardware, whenever an update of the values is finished. Therefore every time that an update of the registers is needed the software must set again the specific bit(s).

Nevertheless it is also possible to clear the enable bit via software. This can be used in the case that an update of the values needs to be cancelled (after the enable bit has already been set).





**Figure 19-9 Shadow transfer enable logic**

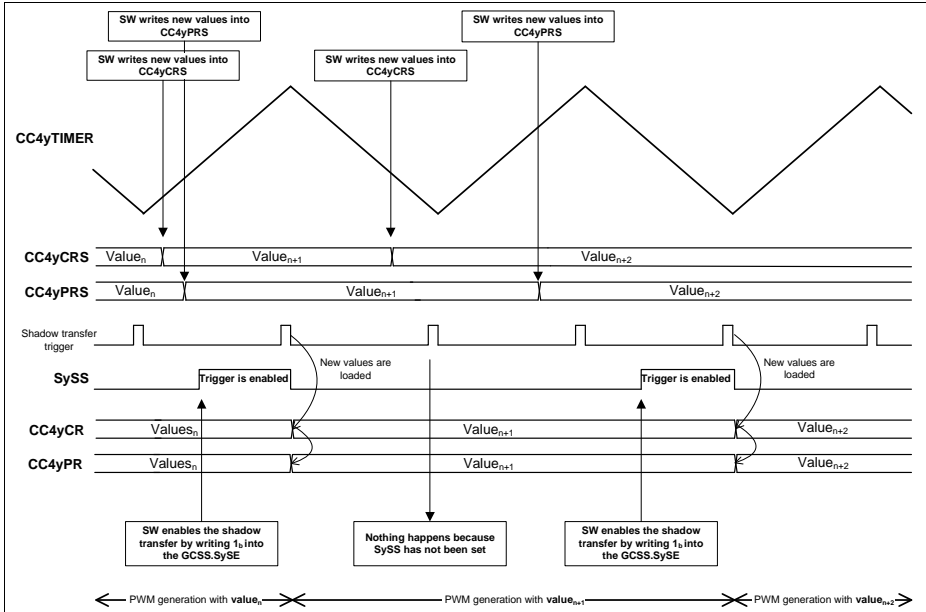
The shadow transfer operation is going to be done in the immediately next occurrence of a shadow transfer trigger, after the shadow transfer enable is set (**GCST.SySS**, **GCST.SyDSS**, **GCST.SyPSS** set to 1<sub>B</sub>).

The occurrence of the shadow transfer trigger is imposed by the timer counting scheme (edge aligned or center aligned). Therefore the slots when the values are updated can be:

- in the next clock cycle after a Period Match while counting up
- in the next clock cycle after an One Match while counting down
- immediately, if the timer is stopped and the shadow transfer enable bit(s) is set

**Figure 19-10** shows an example of the shadow transfer control when the timer slice has been configured into center aligned mode. For a complete description of all the timer slice counting modes, please address [Section 19.2.5.3](#), [Section 19.2.5.4](#) and [Section 19.2.5.5](#).

**Capture/Compare Unit 4 (CCU4)**



**Figure 19-10 Shadow transfer timing example - center aligned mode**

In some application cases it may be necessary to request shadow transfers not by software but by hardware. To perform this action each CCU4 contains a dedicated input that can be used to request a shadow transfer by hardware, the CCU4x.MCSS.

This input, when enabled, is used to set the shadow transfer enable bitfields (**GCST.SySS**, **GCST.SyDSS** and **GCST.SyPSS**) of the specific slice. It is possible to select which slice is using this input to perform the synchronization via the **GCTRL.MSEy** bit field. It is also possible to enable the usage of this signal for the three different shadow transfer signals: compare and period values, dither compare value and prescaler compare value. This can be configured on the **GCTRL.MSDE** field.

The structure for using the CCU4x.MCSS input signal can be seen in **Figure 19-9**. The usage of this signal is just an add on to the shadow transfer control and therefore all the previous described functions are still available.

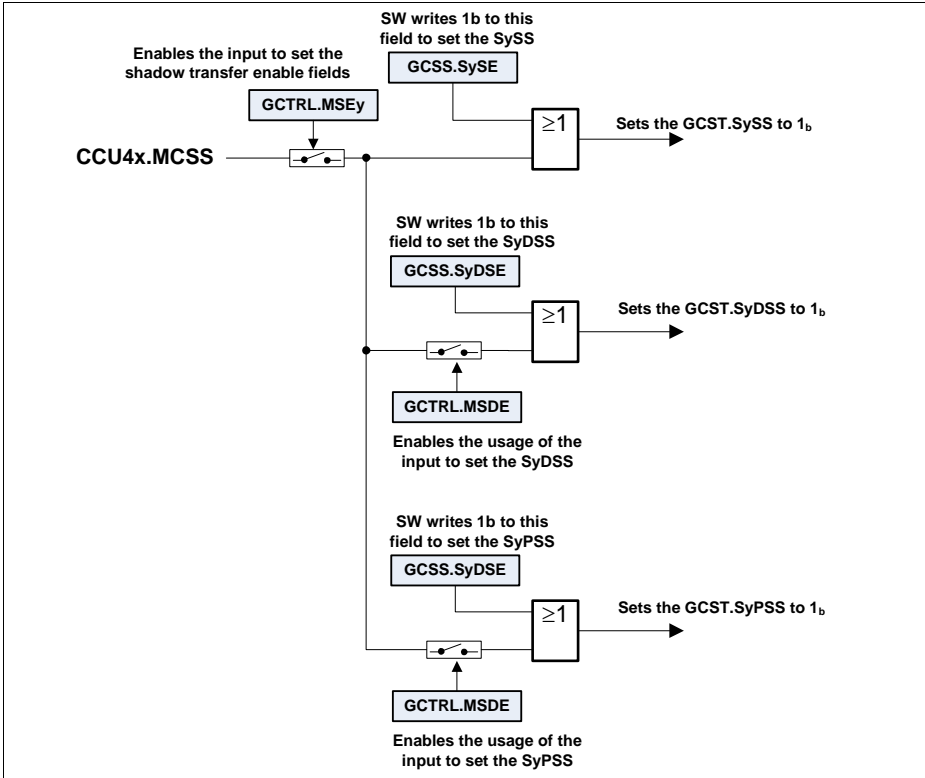


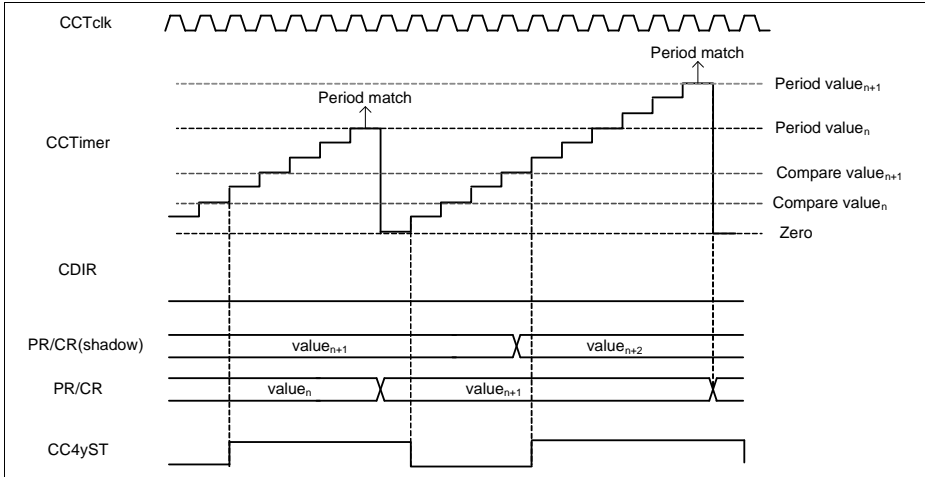
Figure 19-11 Usage of the CCU4x.MCSS input

### 19.2.5.3 Edge Aligned Mode

Edge aligned mode is the default counting scheme. In this mode, the timer is incremented until it matches the value programmed in the period register, **CC4yPR**. When period match is detected the timer is cleared to 0000<sub>H</sub> and continues to be incremented.

In this mode, the value of the period register and compare register are updated with the value written by software into the correspondent shadow register, every time that an overflow occurs (period match), see **Figure 19-12**.

In edge aligned mode, the status bit of the comparison (CC4yST) is set one clock cycle after the timer hits the value programmed into the compare register. The clear of the status bit is done one clock cycle after the timer reaches 0000<sub>H</sub>.



**Figure 19-12 Edge aligned mode,  $CC4yTCM = 0_B$**

### 19.2.5.4 Center Aligned Mode

In center aligned mode, the timer is counting up or down with respect to the following rules:

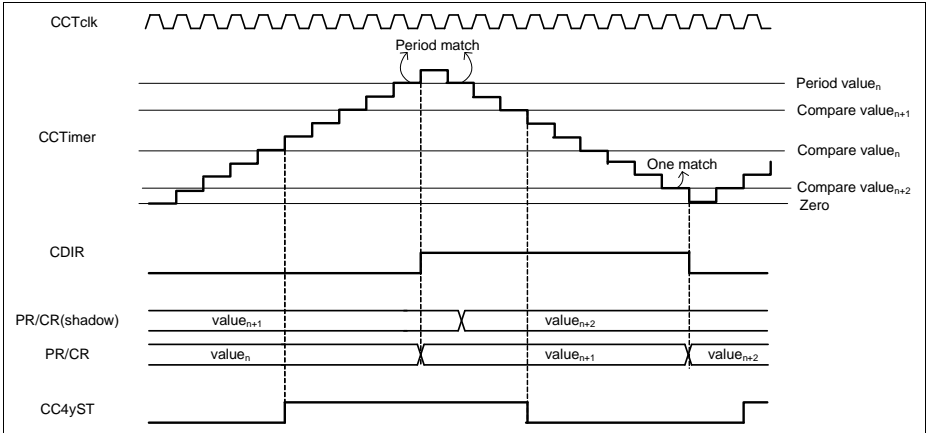
- The counter counts up while  $CC4yTCST.CDIR = 0_B$  and it counts down while  $CC4yTCST.CDIR = 1_B$ .
- Within the next clock cycle, the count direction is set to counting up ( $CC4yTCST.CDIR = 0_B$ ) when the counter reaches  $0001_H$  while counting down.
- Within the next clock cycle, the count direction is set to counting down ( $CC4yTCST.CDIR = 1_B$ ), when the period match is detected while counting up.

The status bit ( $CC4yST$ ) is always  $1_B$  when the counter value is equal or greater than the compare value and  $0_B$  otherwise.

While in edge aligned mode, the shadow transfer for compare and period registers is executed once per period. It is executed twice in center aligned mode as follows

- Within the next clock cycle after the counter reaches the period value, while counting up ( $CC4yTCST.CDIR = 0_B$ ).
- Within the next clock cycle after the counter reaches  $0001_H$ , while counting down ( $CC4yTCST.CDIR = 1_B$ ).

*Note: Bit  $CC4yTCST.CDIR$  changes within the next timer clock after the one-match or the period-match, which means that the timer continues counting in the previous direction for one more cycle before changing the direction.*

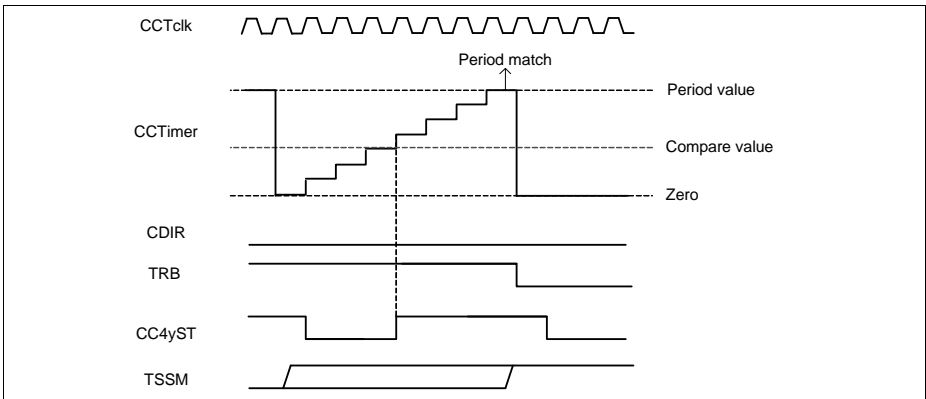


**Figure 19-13 Center aligned mode,  $CC4yTC.TCM = 1_B$**

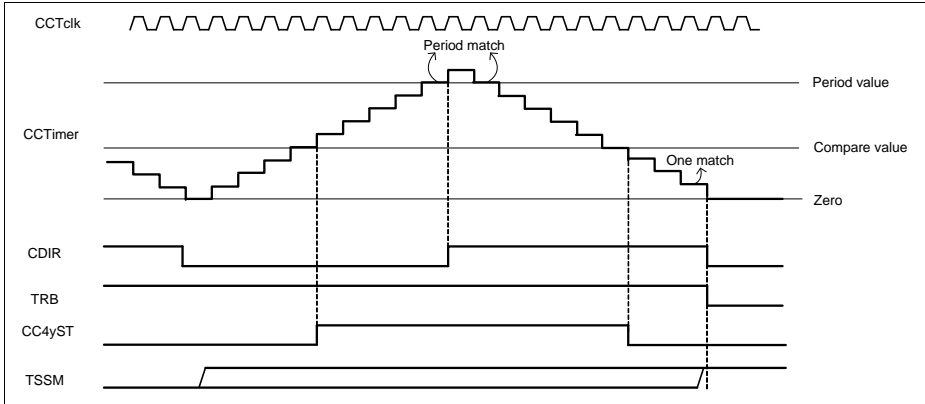
### 19.2.5.5 Single Shot Mode

In single shot mode, the timer is stopped after the current timer period is finished. This mode can be used with center or edge aligned scheme.

In edge aligned mode, **Figure 19-14**, the timer is stopped when it is cleared to 0000<sub>H</sub> after having reached the period value. In center aligned mode, **Figure 19-15**, the period is finished when the timer has counted down to 0000<sub>H</sub>.



**Figure 19-14 Single shot edge aligned -  $CC4yTC.TSSM = 1_B$ ,  $CC4yTC.TCM = 0_B$**



**Figure 19-15 Single shot center aligned -  $CC4yTC.TSSM = 1_B$ ,  $CC4yTC.TCM = 1_B$**

## 19.2.6 Active/Passive Rules

The general rules that set or clear the associated timer slice status bit (CC4yST), can be generalized independently of the timer counting mode.

The following events set the Status bit (CC4yST) to Active:

- in the next  $f_{tclk}$  cycle after a compare match while counting up
- in the next  $f_{tclk}$  cycle after a zero match while counting down

The following events set the Status bit (CC4yST) to Inactive:

- in the next  $f_{tclk}$  cycle after a zero match (and not compare match) while counting up
- in the next  $f_{tclk}$  cycle after a compare match while counting down

If external events are being used to control the timer operation, these rules are still applicable.

The status bit state can only be 'override' via software or by the external status bit override function, [Section 19.2.7.10](#).

The software can at any time write a  $1_B$  into the [GCSS.SySTS](#) bitfield, which will set the status bit [GCST.CC4yST](#) of the specific timer slice. Writing a  $1_B$  into the [GCSC.SySTC](#) bitfield will clear the specific status bit.

## 19.2.7 External Events Control

Each CCU4 timer slice has the possibility of using up to three different input events, see [Section 19.2.2](#). These three events can then be mapped to Timer Slice functions (the full set of available functions is described at [Section 19.2.3](#))

These events can be mapped to any of the CCU4x.INy[P...A] inputs and there isn't any imposition that an event cannot be used to perform several functions, or that an input

cannot be mapped to several events (e.g. input X triggers event 0 with rising edge and triggers event 1 with the falling edge).

### 19.2.7.1 External Start/Stop

To select an external start function, one should map one of the events (output of the input selector) to a specific input signal, by setting the required value in the **CC4yINS.EVxIS** field and indicating the active edge of the signal on the **CC4yINS.EVxEM** field.

This event should be then mapped to the start or stop functionality by setting the **CC4yCMC.STRTS** (for the start) or the **CC4yTC.ENDM** (for the stop) with the proper value.

Notice that both start and stop functions are edge and not level active and therefore the active/passive configuration is set only by the **CC4yINS.EVxEM**.

The external stop by default just clears the run bit (**CC4yTCST.TRB**), while the start functions does the opposite. Nevertheless one can select an extended subset of functions for the external start and stop. This subset is controlled by the registers **CC4yTC.ENDM** (for the stop) and **CC4yTC.STRM** (for the start).

For the start subset (**CC4yTC.STRM**):

- sets the run bit/starts the timer (resume operation)
- clears the timer, sets the run bit/starts the timer (flush and start)

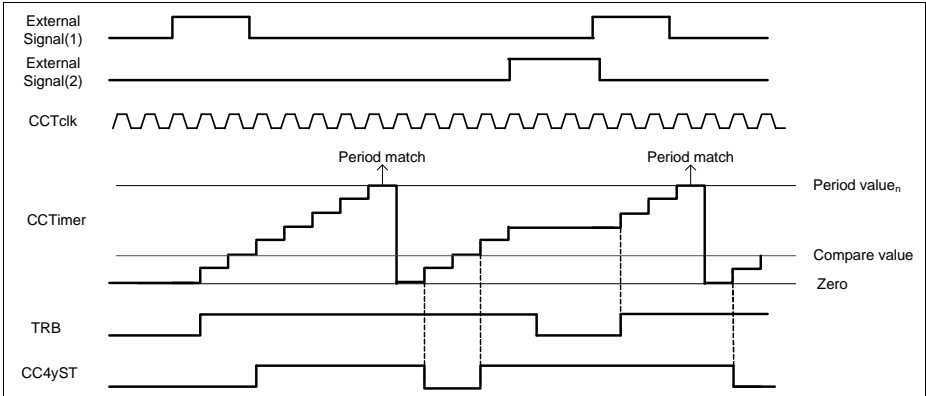
For the stop subset (**CC4yTC.ENDM**):

- clears the run/stops the timer (stop)
- clears the timer (flush)
- clears the timer, clears the run bit/stops the timer (flush and stop)

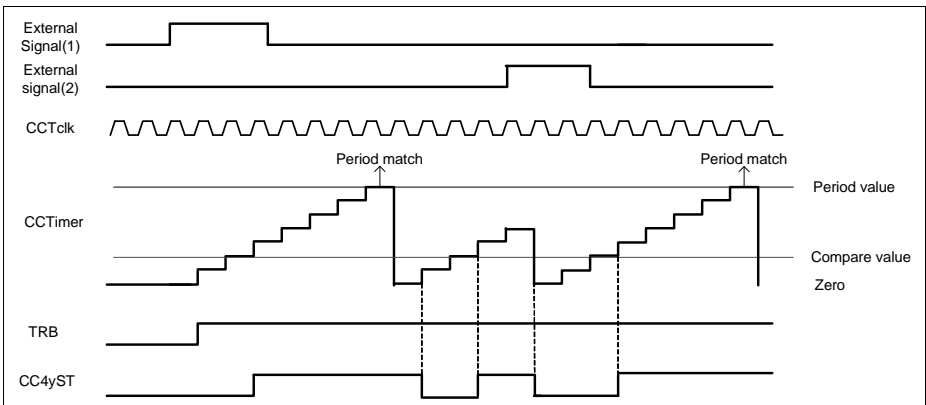
If in conjunction with an external start/stop (configured also/only as flush) and external up/down signal is used, during the flush operation the timer is going to be set to 0000<sub>H</sub> if the actual counting direction is up or set with the value of the period register if the counting direction is down.

**Figure 19-16** to **Figure 19-19** shows the usage of two signals to perform the start/stop functions in all the previously mentioned subsets. External Signal(1) acts as an active HIGH start signal, while External Signal(2) is used as an active HIGH stop function.

**Capture/Compare Unit 4 (CCU4)**



**Figure 19-16 Start (as start)/ stop (as stop) -  $CC4yTC.STRM = 0_B$ ,  $CC4yTC.ENDM = 00_B$**



**Figure 19-17 Start (as start)/ stop (as flush) -  $CC4yTC.STRM = 0_B$ ,  $CC4yTC.ENDM = 01_B$**



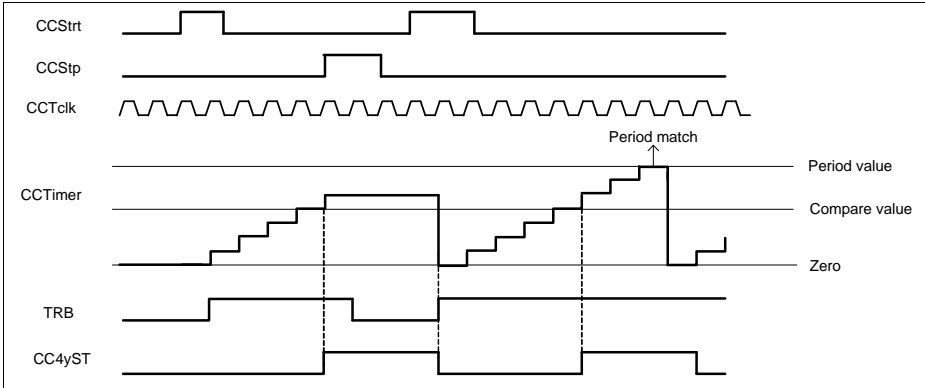


Figure 19-18 Start (as flush and start)/ stop (as stop) -  $CC4yTC.STRM = 1_B$ ,  
 $CC4yTC.ENDM = 00_B$

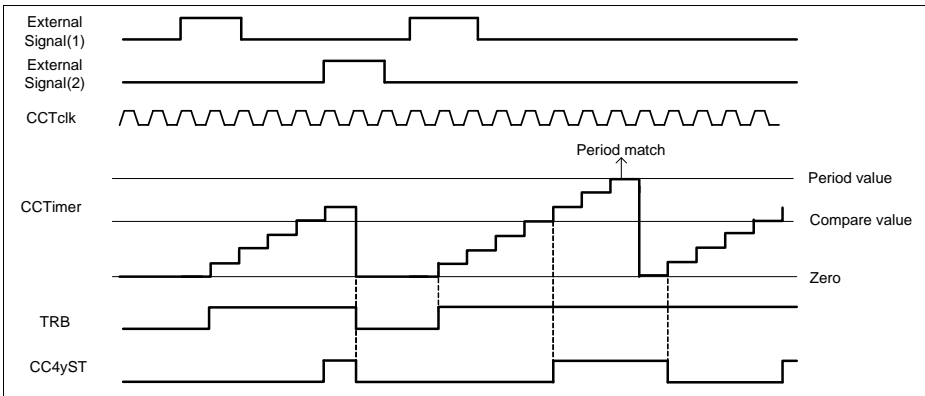


Figure 19-19 Start (as start)/ stop (as flush and stop) -  $CC4yTC.STRM = 0_B$ ,  
 $CC4yTC.ENDM = 10_B$

### 19.2.7.2 External Counting Direction

There is the possibility of selecting an input signal to act as increment/decrement control. To select an external up/down control, one should map one of the events (output of the input selector) to a specific input signal, by setting the required value in the  $CC4yINS.EVxIS$  field and indicating the active level of the signal on the  $CC4yINS.EVxLM$ . This event should be then mapped to the up/down functionality by setting  $CC4yCMC.UDS$  with the proper value.

**Capture/Compare Unit 4 (CCU4)**

Notice that the up/down function is level active and therefore the active/passive configuration is set only by the **CC4yINS.EVxLM**.

The status bit of the slice (**CC4yST**) is always set when the timer value is equal or greater than the value stored in the compare register, see **Section 19.2.6**.

The update of the period and compare register values is done when:

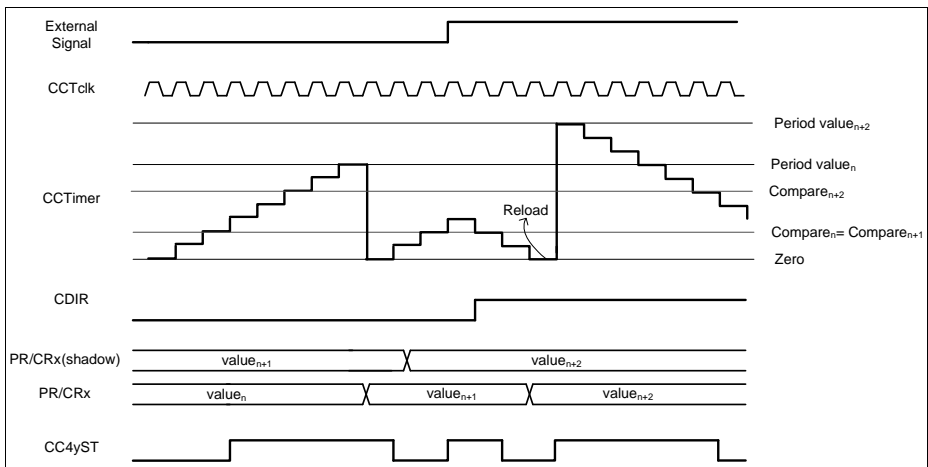
- with the next clock after a period match, while counting up (**CC4yTCST.CDIR** = 0<sub>B</sub>)
- with the next clock after a one match, while counting down (**CC4yTCST.CDIR** = 1<sub>B</sub>)

The value of the **CC4yTCST.CDIR** register is updated accordingly with the changes on the decoded event. The Up/Down direction is always understood as **CC4yTCST.CDIR** = 1<sub>B</sub> when counting down and **CC4yTCST.CDIR** = 0<sub>B</sub> when counting up. Using an external signal to perform the up/down counting function and configuring the event as active HIGH means that the timer is counting up when the signal is HIGH and counting down when LOW.

**Figure 19-20** shows an external signal being used to control the counting direction of the time. This signal was selected as active HIGH, which means that the timer is counting down while the signal is HIGH and counting up when the signal is LOW.

*Note: For a signal that should impose an increment when LOW and a decrement when HIGH, the user needs to set the **CC4yINS.EVxLM** = 0<sub>B</sub>. When the operation is switched, then the user should set **CC4yINS.EVxLM** = 1<sub>B</sub>.*

*Note: Using an external counting direction control, sets the slice in edge aligned mode.*



**Figure 19-20 External counting direction**

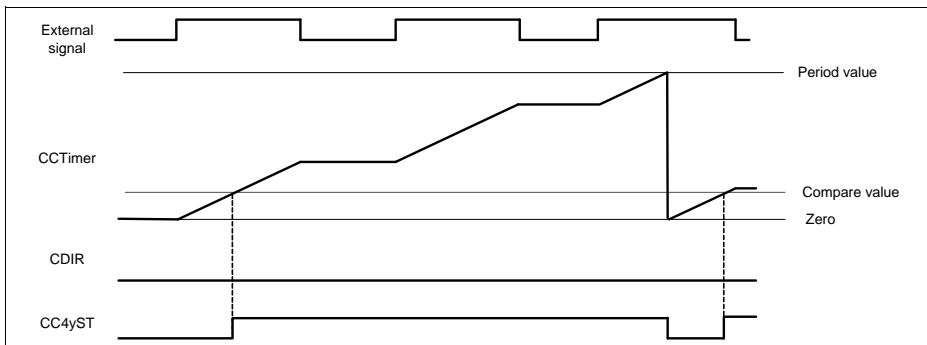
### 19.2.7.3 External Gating Signal

For pulse measurement, the user has the possibility of selecting an input signal that operates as counting gating.

To select an external gating control, one should map one of the events (output of the input selector) to a specific input signal, by setting the required value in the **CC4yINS.EVxIS** register and indicating the active level of the signal on the **CC4yINS.EVxLM** register. This event should be then mapped to the gating functionality by setting the **CC4yCMC.GATES** with the proper value.

Notice that the gating function is level active and therefore the active/passive configuration is set only by the **CC4yINS.EVxLM**.

The status bit during an external gating signal continues to be asserted when the compare value is reached and deasserted when the counter reaches 0000<sub>H</sub>. One should note that the counter continues to use the period register to identify the wrap around condition. **Figure 19-21** shows the usage of an external signal for gating the slice counter. The signal was set as active LOW, which means the counter gating functionality is active when the external value is zero.



**Figure 19-21 External gating**

For any type of usage of the external gating function, the specific rung bit of the Timer Slice, **CC4yTCST.TRB**, needs to be set. This can be done via an additional external signal or directly via software.

### 19.2.7.4 External Count Signal

There is also the possibility of selecting an external signal to act as the counting event.

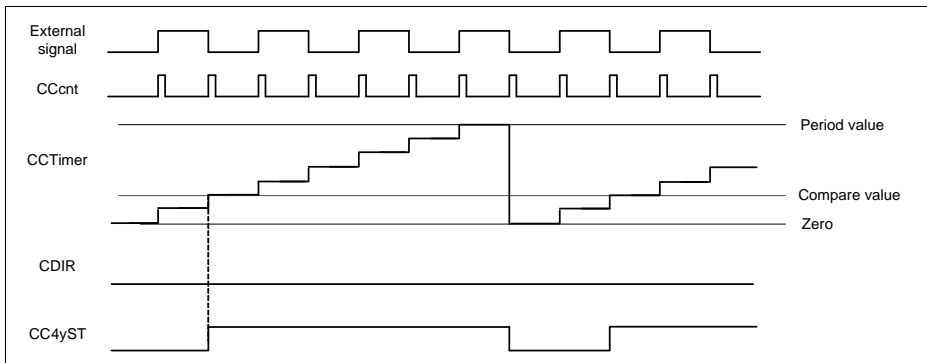
To select an external counting, one should map one of the events (output of the input selector) to a specific input signal, by setting the required value in the **CC4yINS.EVxIS** register and indicating the active edge of the signal on the **CC4yINS.EVxEM** register.

**Capture/Compare Unit 4 (CCU4)**

This event should be then mapped to the counting functionality by setting the **CC4yCMC.CNTS** with the proper value.

Notice that the counting function is edge active and therefore the active/passive configuration is set only by the **CC4yINS.EVxEM**.

One can select just a the rising, falling or both edges to perform a count. On **Figure 19-22**, the external signal was selected as a counter event for both falling and rising edges. Wrap around condition is still applied with a comparison with the period register.



**Figure 19-22 External count**

For any type of usage of the external gating function, the specific rung bit of the Timer Slice, **CC4yTCST.TRB**, needs to be set. This can be done via an additional external signal or directly via software.

**19.2.7.5 External Load**

Each slice of the CCU4 also has a functionality that enables the user to select an external signal as trigger for reloading the value of the timer with the current value of the compare register (if **CC4yTCST.CDIR = 0<sub>B</sub>**) or with the value of the period register (if **CC4yTCST.CDIR = 1<sub>B</sub>**).

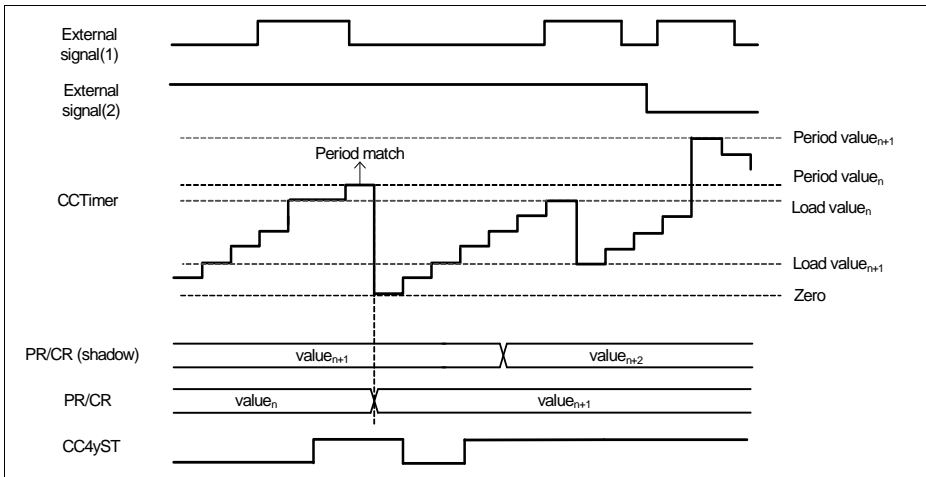
To select an external load signal, one should map one of the events (output of the input selector) to a specific input signal, by setting the required value in the **CC4yINS.EVxIS** register and indicating the active edge of the signal on the **CC4yINS.EVxEM** register. This event should be then mapped to the load functionality by setting the **CC4yCMC.LDS** with the proper value.

Notice that the load function is edge active and therefore the active/passive configuration is set only by the **CC4yINS.EVxEM**.

On figure **Figure 19-23**, the external signal (1) was used to act as a load trigger, active on the rising edge. Every time that a rising edge on external signal (1) is detected, the

**Capture/Compare Unit 4 (CCU4)**

timer value is loaded with the value present on the compare register. If an external signal is being used to control the counting direction, up or down, the timer value can be loaded also with the value set in the period register. The External signal (2) represents the counting direction control (active HIGH). If at the moment that a load trigger is detected, the signal controlling the counting direction is imposing a decrement, then the value set in the timer is the period value.



**Figure 19-23 External load**

### 19.2.7.6 External Capture

When selecting an external signal to be used as a capture trigger (if **CC4yCMC.CAP0S** or **CC4yCMC.CAP1S** are different from 0<sub>H</sub>), the user is automatically setting the specific slice into capture mode.

In capture mode the user can have up to four capture registers, see **Figure 19-26**: capture register 0 (**CC4yC0V**), capture register 1 (**CC4yC1V**), capture register 2 (**CC4yC2V**) and capture register 3 (**CC4yC3V**).

These registers are shared between compare and capture modes which imposes:

- if **CC4yC0V** and **CC4yC1V** are used for capturing, the compare registers **CC4yCR** and **CC4yCRS** are not available (no compare channel)
- if **CC4yC2V** and **CC4yC3V** are used for capturing, the period registers **CC4yPR** and **CC4yPRS** are not available (no period control)

To select an external capture signal, one should map one of the events (output of the input selector) to a specific input signal, by setting the required value in the **CC4yINS.EVxIS** register and indicating the active edge of the signal on the

## Capture/Compare Unit 4 (CCU4)

**CC4yINS.EVxEM** register. This event should be then mapped to the capture functionality by setting the **CC4yCMC.CAP0S/CC4yCMC.CAP1S** with the proper value. Notice that the capture function is edge active and therefore the active/passive configuration is set only by the **CC4yINS.EVxEM**.

The user has the possibility of selecting the following capture schemes:

- Different capture events for **CC4yC0V/CC4yC1V** and **CC4yC2V/CC4yC3V**
- The same capture event for **CC4yC0V/CC4yC1V** and **CC4yC2V/CC4yC3V** with the same capture edge. For this capture scheme, only the CCcapt1 functionality needs to be programmed. To enable this scheme, the field **CC4yTC.SCE** needs to be set to 1.

### Different Capture Events (SCE = 0<sub>B</sub>)

Every time that a capture trigger 1 occurs, CCcapt1, the actual value of the timer is captured into the capture register 3 and the previous value stored in this register is transferred into capture register 2.

Every time that a capture trigger 0 occurs, CCcapt0, the actual value of the timer is captured into the capture register 1 and the previous value stored in this register is transferred into capture register 0.

Every time that a capture procedure into one of the registers occurs, the respective full flag is set. This flag is cleared automatically by HW when the SW reads back the value of the capture register (by reading the specific capture register or by reading the extended capture read value, see [Section 19.2.7.7](#)).

The capture of a new value into a specific capture registers is dictated by the status of the full flag as follows:

$$CC4yCIV_{capt} = \text{NOT}(CC4yCIV_{full\_flag} \text{ AND } CC4yC0V_{full\_flag}) \quad (19.4)$$

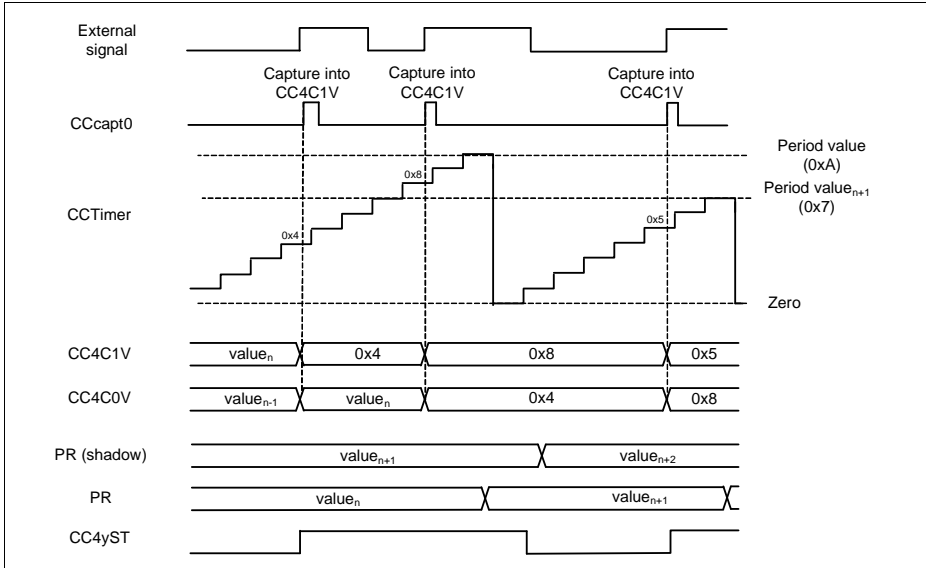
$$CC4yC0V_{capt} = CC4yCIV_{full\_flag} \text{ AND } \text{NOT}(CC4yC0V_{full\_flag}) \quad (19.5)$$

It is also possible to disable the effect of the full flags reset by setting the **CC4yTC.CCS = 1<sub>B</sub>**. This enables a continuous capturing independent if the values captured have been read or not.

*Note: When using the period registers for capturing, **CC4yCMC.CAP1S** different from 00<sub>B</sub>, the counter always uses its full 16 bit width as period value.*

On [Figure 19-24](#), an external signal was selected as an event for capturing the timer value into the **CC4yC0V/CC4yC1V** registers. The status bit, CC4yST, during capture mode is asserted whenever a capture trigger is detected and deasserted when the counter matches 0000<sub>H</sub>.

**Capture/Compare Unit 4 (CCU4)**



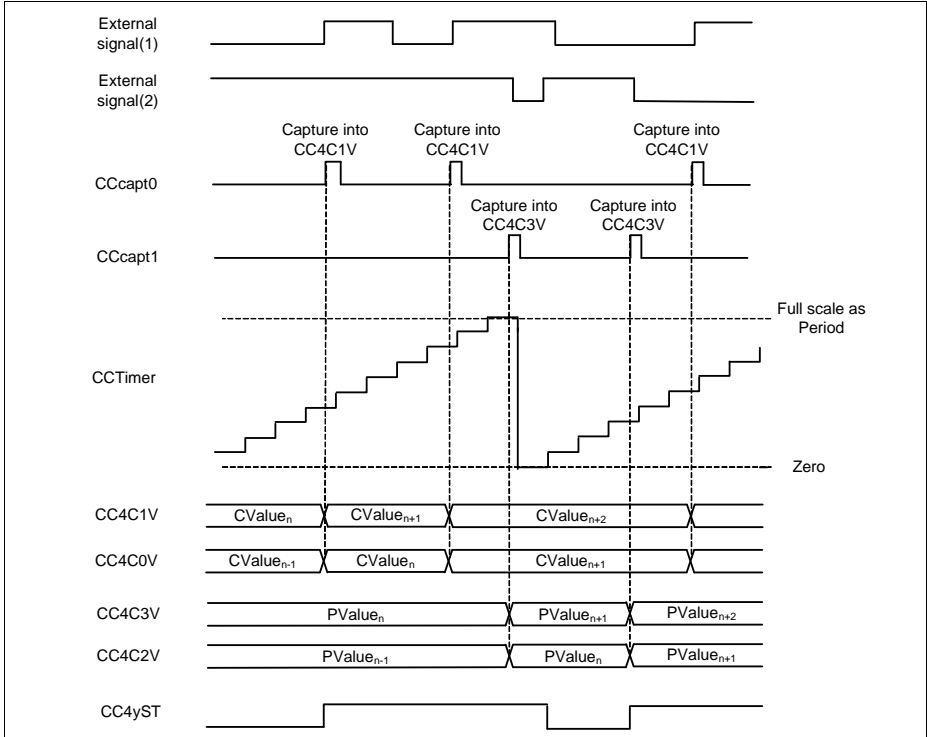
**Figure 19-24 External capture -  $CC4yCMC.CAP0S \neq 00_B$ ,  $CC4yCMC.CAP1S = 00_B$**

On [Figure 19-25](#), two different signals were used as source for capturing the timer value into the [CC4yC0V/CC4yC1V](#) and [CC4yC2V/CC4yC3V](#) registers.

External signal(1) was selected as rising edge active capture source for [CC4yC0V/CC4yC1V](#). External signal(2) was selected as the capture source for [CC4yC2V/CC4yC3V](#), but as opposite to the external signal(1), the active edge was selected has falling.

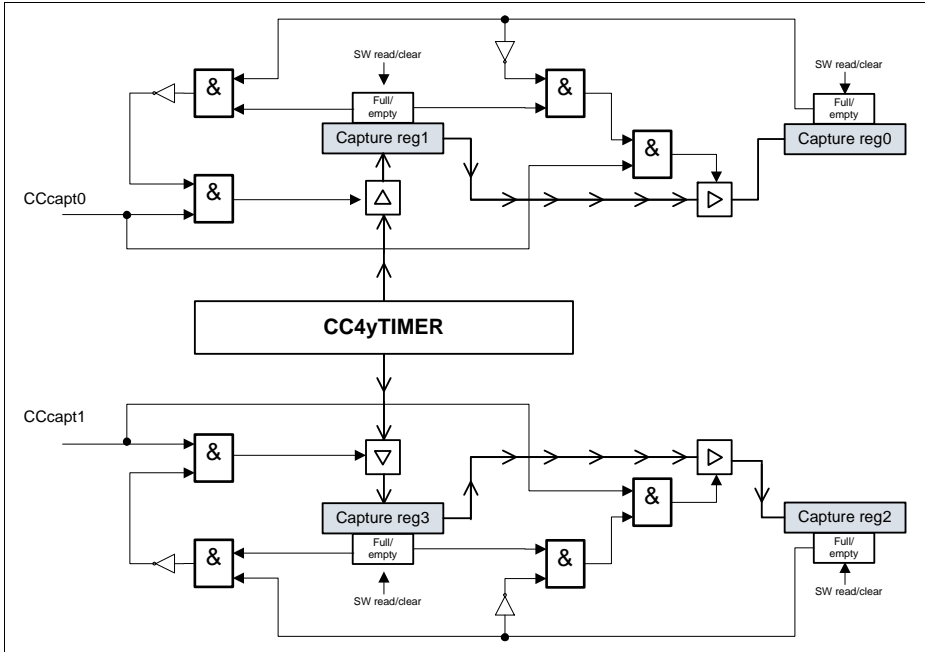
See [Section 19.2.12.4](#), for the complete capture mode usage description.

**Capture/Compare Unit 4 (CCU4)**



**Figure 19-25 External capture -  $CC4yCMC.CAP0S \neq 00_B$ ,  $CC4yCMC.CAP1S \neq 00_B$**





**Figure 19-26 Slice capture logic**

**Same Capture Event (SCE = 1<sub>B</sub>)**

Setting the field **CC4yTC.SCE = 1<sub>B</sub>**, enables the possibility of having 4 capture registers linked with the same capture event, **Figure 19-28**. The function that controls the capture is the CCcapt1.

The capture logic follows the same structure shown in **Figure 19-26** but extended to a four register chain, see **Figure 19-27**. The same full flag lock rules are applied to the four register chain (it also can be disabled by setting the **CC4yTC.CCS = 1<sub>B</sub>**):

$$CC4yC3V_{capt} = \text{NOT}(CC4yC3V_{full\_flag} \text{ AND } CC4yC2V_{full\_flag} \text{ AND } CC4yC2V_{full\_flag} \text{ AND } CC4yC1V_{full\_flag}) \quad (19.6)$$

$$CC4yC2V_{capt} = CC4yC3V_{full\_flag} \text{ AND NOT}(CC4yC2V_{full\_flag} \text{ AND } CC4yC1V_{full\_flag} \text{ AND } CC4yC0V_{full\_flag}) \quad (19.7)$$

$$CC4yC1V_{capt} = CC4yC2V_{full\_flag} \text{ AND NOT}(CC4yC1V_{full\_flag} \text{ AND } CC4yC0V_{full\_flag}) \quad (19.8)$$

$$CC4yC0V_{capt} = CC4yC1V_{full\_flag} \text{ AND NOT}(CC4yC0V_{full\_flag}) \quad (19.9)$$

Capture/Compare Unit 4 (CCU4)

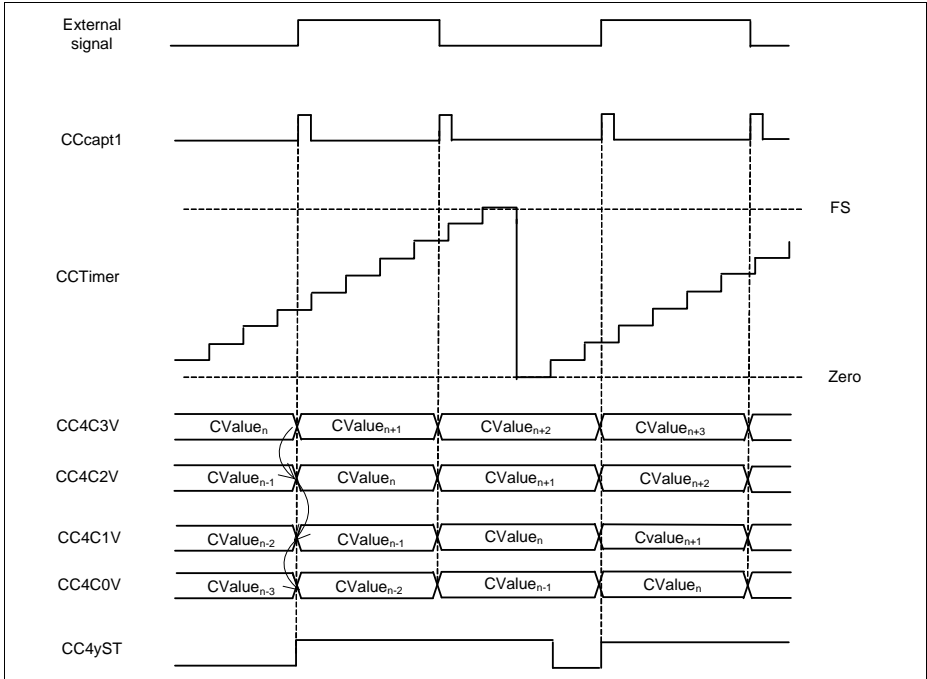


Figure 19-27 External Capture - **CC4yTC.SCE = 1<sub>B</sub>**

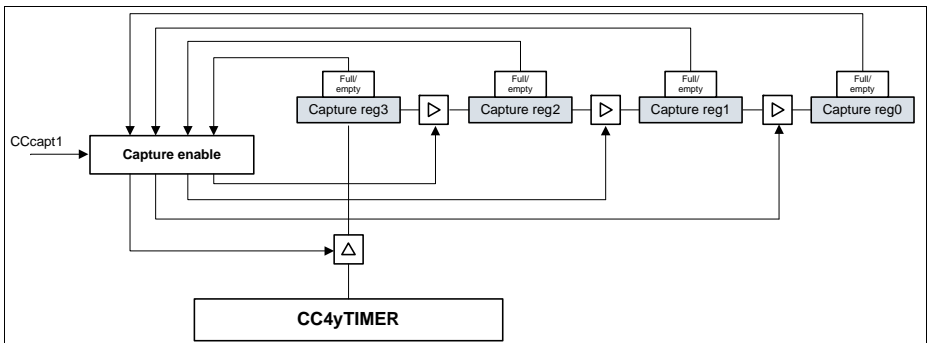


Figure 19-28 Slice Capture Logic - **CC4yTC.SCE = 1<sub>B</sub>**

### 19.2.7.7 Capture Extended Read Back Mode

Each Timer Slice capture logic can operate in a FIFO read back mode. This mode can be enabled by setting the **CC4yTC.ECM** = 1<sub>B</sub>. This Extended Read back mode allows the software to read back the capture data always from the same address (**CC4yECRD0** for the structure linked with the capture trigger 0 or **CC4yECRD1** for the one linked with capture trigger 1). This read back will always return the oldest captured value, enabling an easy software routine implementation for reconstructing the capture data.

This function allows the usage of a FIFO structure for each capturing trigger. This relaxes the software read back routine when multiple capture triggers are present, and the software is not fast enough to perform a read operation in each capture event.

This FIFO read back function is present for a depth-4 and depth-2 FIFO structure.

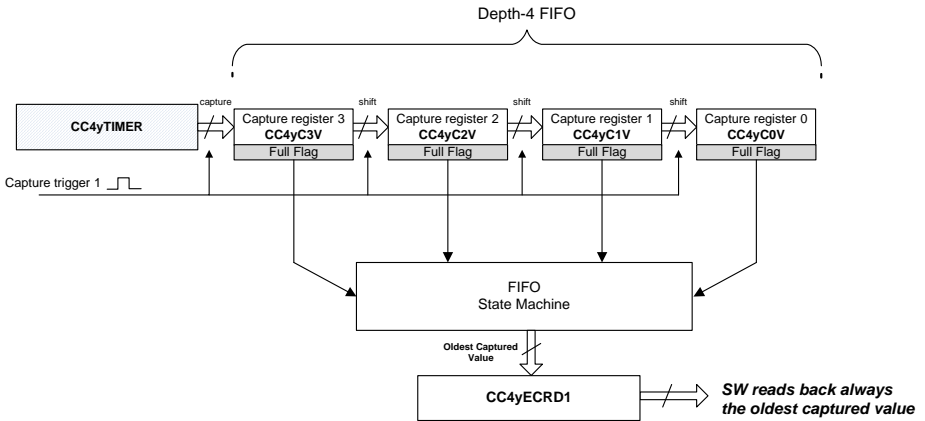
The read back data contains also a lost value bitfield, that indicates if a capture trigger was lost due to the fact that the FIFO structure was full. This bitfield is set whenever a capture event was sensed and the FIFO was full (regardless if the continuous capture mode was enabled or not). This bitfield is cleared automatically by HW whenever the next read of the **CC4yECRD0/CC4yECRD1** register occurs. This bitfield does not indicate how many capture events were lost, it just indicates that between two ECRD reads at least a capture event was lost (this can help the SW evaluate which part of the data read, can be used for calculation).

*Note: When the ECM bitfield is set, reading the individual capture registers is still possible. Nevertheless the full flags can only be cleared by the HW when a read back is done via the **CC4yECRD0/CC4yECRD1** address.*

#### Depth 4 Structure

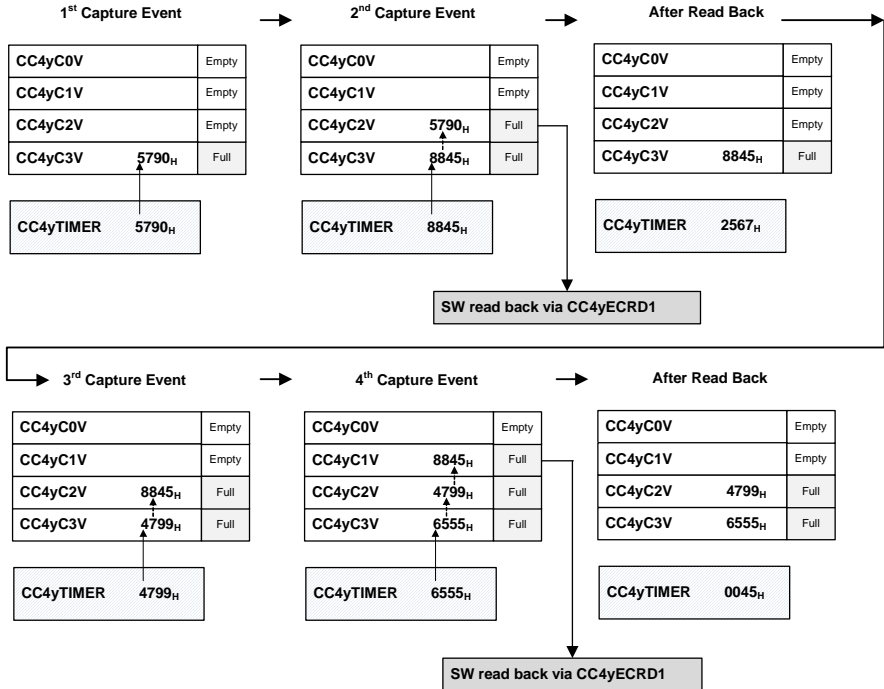
The FIFO depth-4 structure is present in the hardware when the capture trigger 1 is enabled and the **CC4yTC.SCE** = 1<sub>B</sub> (same capture event), **Figure 19-29**.

**Capture/Compare Unit 4 (CCU4)**



**Figure 19-29 Capture Extended Read Back - Depth 4**

**Capture/Compare Unit 4 (CCU4)**



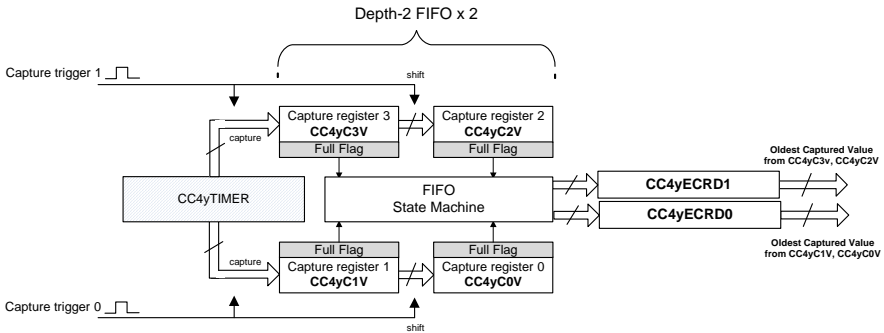
**Figure 19-30 Depth 4 software access example**

**Depth 2 Structure**

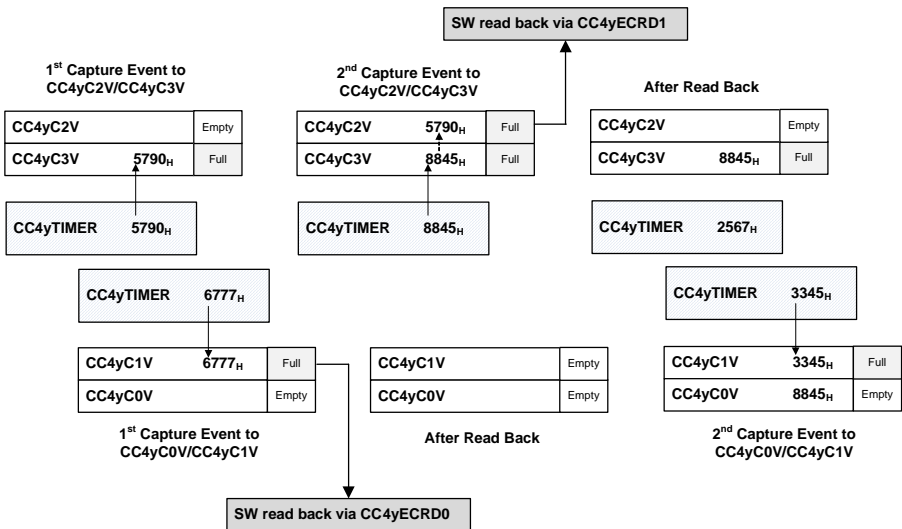
Each Timer Slice can have two capture structures of depth-2: one used with capture trigger 0 and another with capture trigger 1.

The one linked with capture trigger 0, is accessed via the **CC4yECDR0** while the one linked with the capture trigger 1 is accessed via the **CC4yECDR1**, **Figure 19-31**.

**Capture/Compare Unit 4 (CCU4)**



**Figure 19-31 Capture Extended Read Back - Depth 2**



**Figure 19-32 Depth 2 software access example**

**19.2.7.8 External Modulation**

An external signal can be used to perform a modulation at the output of each timer slice. To select an external modulation signal, one should map one of the input signals to one of the events, by setting the required value in the **CC4yINS.EVxIS** register and indicating the active level of the signal on the **CC4yINS.EVxLM** register. This event should be then

**Capture/Compare Unit 4 (CCU4)**

mapped to the modulation functionality by setting the **CC4yCMC.MOS** = 01<sub>B</sub> if event 0 is being used, **CC4yCMC.MOS** = 10<sub>B</sub> if event 1 or **CC4yCMC.MOS** = 11<sub>B</sub> if event 2.

Notice that the modulation function is level active and therefore the active/passive configuration is set only by the **CC4yINS.EVxLM**.

The modulation has two modes of operation:

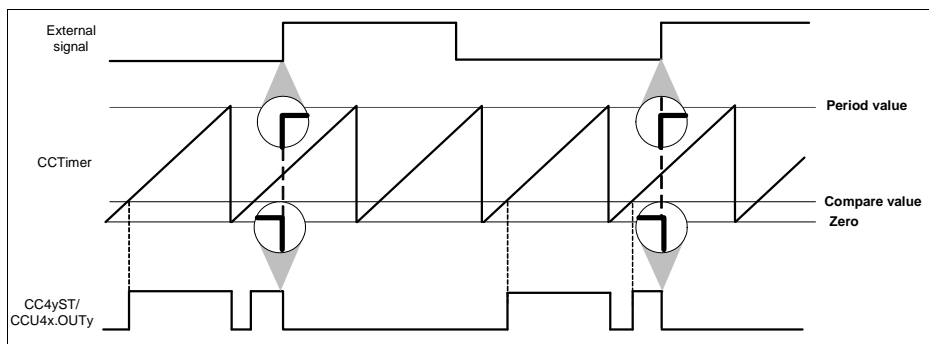
- modulation event is used to clear the CC4yST bit - **CC4yTC.EMT** = 0<sub>B</sub>
- modulation event is used to gate the outputs - **CC4yTC.EMT** = 1<sub>B</sub>

On **Figure 19-33**, we have an external signal configured to act as modulation source that clears the CC4yST bit, **CC4yTC.EMT** = 0<sub>B</sub>. It was programmed to be an active LOW event and therefore, when this signal is LOW the output value follows the normal ACTIVE/PASSIVE rules.

When the signal is HIGH (inactive state), then the CC4yST bit is cleared and the output is forced into the PASSIVE state. Notice that the values of the status bit, CC4yST and the specific output CCU4x.OUTy are not linked together. One can choose for the output to be active LOW or HIGH through the PSL bit.

The exit of the external modulation inactive state is synchronized with the PWM signal due to the fact that the CC4yST bit is cleared and cannot be set while the modulation signal is inactive.

The entering into inactive state also can be synchronized with the PWM signal, by setting **CC4yTC.EMS** = 1<sub>B</sub>. With this all possible glitches at the output are avoided, see **Figure 19-34**.



**Figure 19-33 External modulation clearing the ST bit - **CC4yTC.EMT** = 0<sub>B</sub>**

Capture/Compare Unit 4 (CCU4)

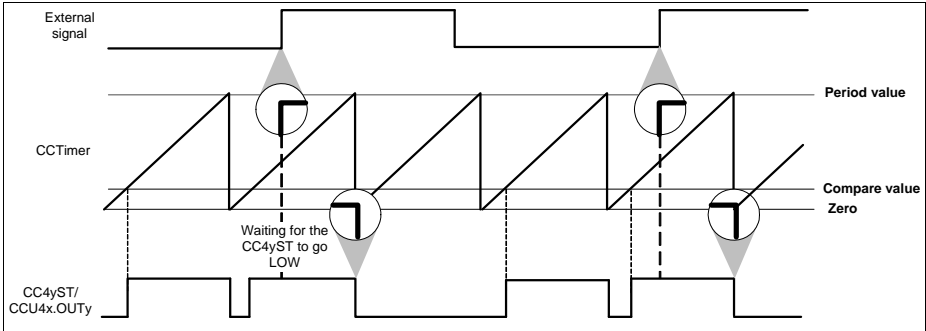


Figure 19-34 External modulation clearing the ST bit -  $CC4yTC.EMT = 0_B$ ,  
 $CC4yTC.EMS = 1_B$

On [Figure 19-35](#), the external modulation event was used as gating signal of the outputs,  $CC4yTC.EMT = 1_B$ . The external signal was configured to be active HIGH,  $CC4yINS.EVxLM = 0_B$ , which means that when the external signal is HIGH the outputs are set to the PASSIVE state. In this mode, the gating event can also be synchronized with the PWM signal by setting the  $CC4yTC.EMS = 1_B$ .

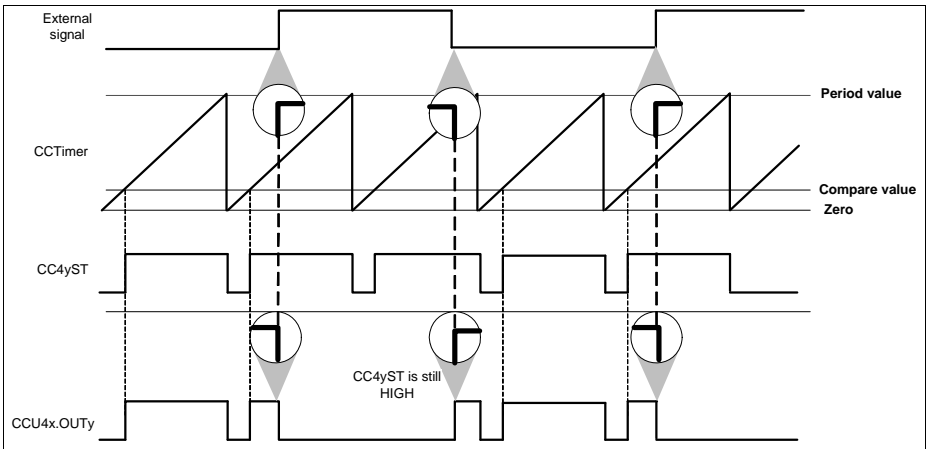


Figure 19-35 External modulation gating the output -  $CC4yTC.EMT = 1_B$



### 19.2.7.9 TRAP Function

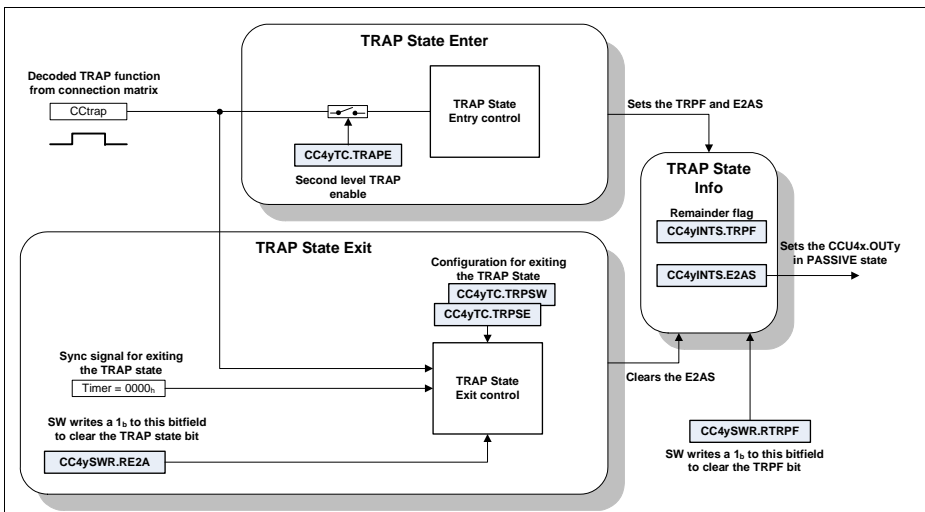
The TRAP functionality allows the PWM outputs to react on the state of an input pin. This functionality can be used to switch off the power devices if the TRAP input becomes active.

To select the TRAP functionality, one should map one of the input signals to event number 2, by setting the required value in the **CC4yINS.EV2IS** register and indicating the active level of the signal on the **CC4yINS.EV2LM** register. This event should be then mapped to the trap functionality by setting the **CC4yCMC.TS = 1<sub>B</sub>**.

Notice that the trap function is level active and therefore the active/passive configuration is set only by the **CC4yINTS.EV2LM**.

There are two bitfields that can be monitored via software to crosscheck the TRAP function, **Figure 19-36**:

- The TRAP state bit, **CC4yINTS.E2AS**. This bitfield is the TRAP is currently active or not. This bitfield is therefore setting the specific Timer Slice output, into ACTIVE or PASSIVE state.
- The TRAP Flag, **CC4yINTS.TRPF**. This bitfield is used as a remainder in the case that the TRAP condition is cleared automatically via hardware. This field needs to be cleared by the software.



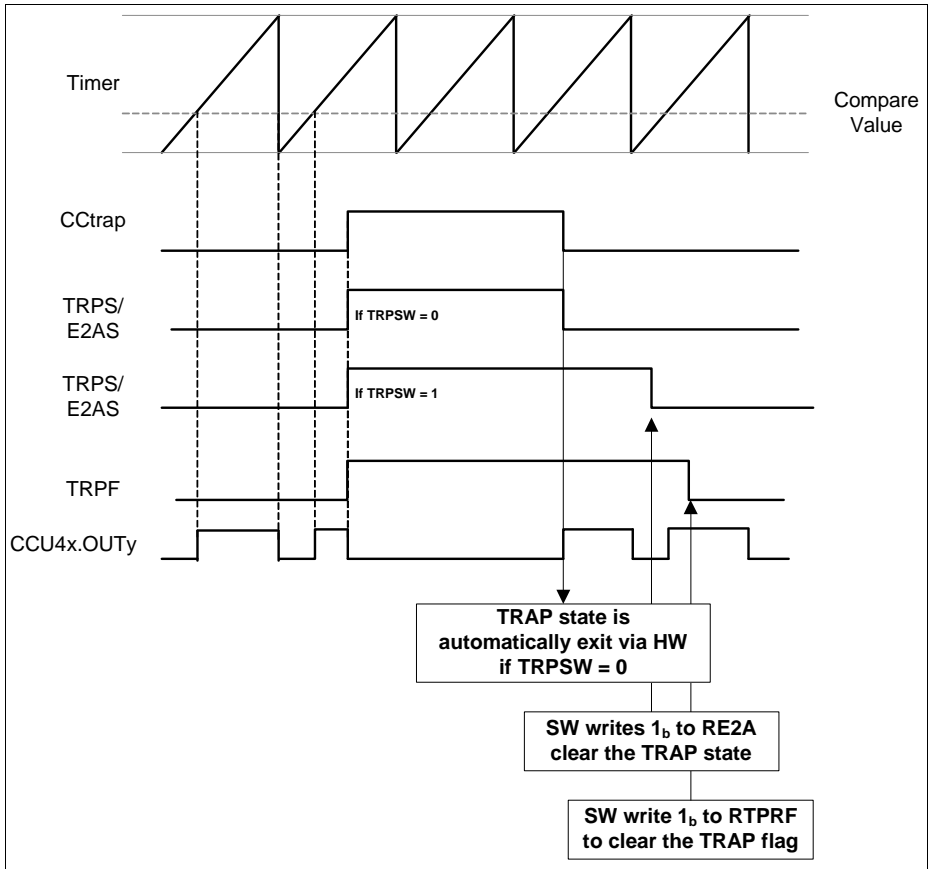
**Figure 19-36 Trap control diagram**

When a TRAP condition is detected at the selected input pin, both the Trap Flag and the Trap State bit are set to 1<sub>B</sub>. The Trap State is entered immediately, by setting the CCU4xOUTy into the programmed PASSIVE state, **Figure 19-37**.

**Capture/Compare Unit 4 (CCU4)**

Exiting the Trap State can be done in two ways (**CC4yTC**.TRPSW register):

- automatically via HW, when the TRAP signal becomes inactive - **CC4yTC**.TRPSW =  $0_B$
- by SW only, by clearing the **CC4yINTS**.E2AS. The clearing is only possible if the input TRAP signal is in inactive state - **CC4yTC**.TRPSW =  $1_B$



**Figure 19-37** Trap timing diagram, **CC4yPSL**.PSL =  $0_B$  (output passive level is  $0_B$ )

It is also possible to synchronize the exiting of the TRAP state with the PWM signal, **Figure 19-38**. This function is enabled when the bitfield **CC4yTC**.TRPSE =  $1_B$ .

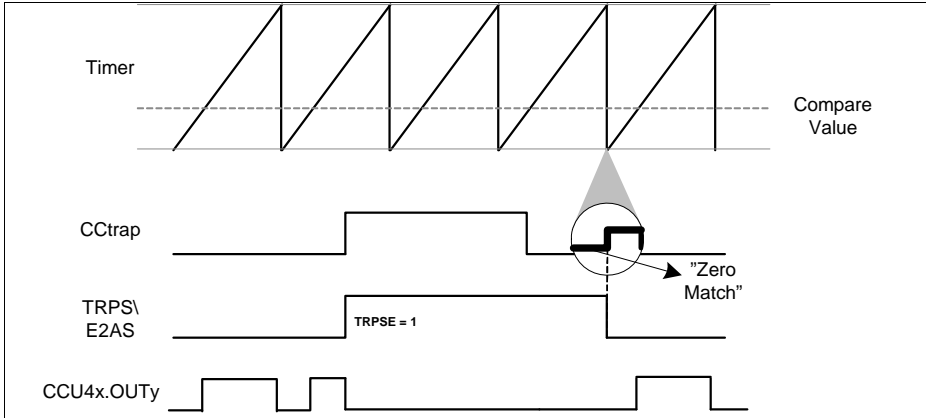


Figure 19-38 Trap synchronization with the PWM signal, **CC4yTC.TRPSE = 1<sub>B</sub>**

### 19.2.7.10 Status Bit Override

For complex timed output control, each Timer Slice has a functionality that enables the override of the status bit (CC4yST) with a value passed through an external signal.

The override of the status bit, can then lead to a change on the output pin, CCU4xOUTy (from inactive to active or vice versa).

To enable this functionality, two signals are needed:

- One signal that acts as a trigger to override the status bit (edge active)
- One signal that contains the value to be set in the status bit (level active)

To use the status bit override functionality, one should map the signal that acts as trigger to the event number 1, by setting the required value in the **CC4yINS.EV1IS** register and indicating the active edge of the signal on the **CC4yINS.EV1EM** register.

The signal that carries the value to be set on the status bit, needs to be mapped to the event number 2, by setting the required value in the **CC4yINS.EV2IS** register. The **CC4yINS.EV2LM** register should be set to 0<sub>B</sub> if no inversion on the signal is needed and to 1<sub>B</sub> otherwise.

The events should be then mapped to the status bit functionality by setting the **CC4yCMC.OFS = 1<sub>B</sub>**.

**Figure 19-39** shows the functionality of the status bit override, when the external signal(1) was selected as trigger source (rising edge active) and the external signal(2) was selected as override value.

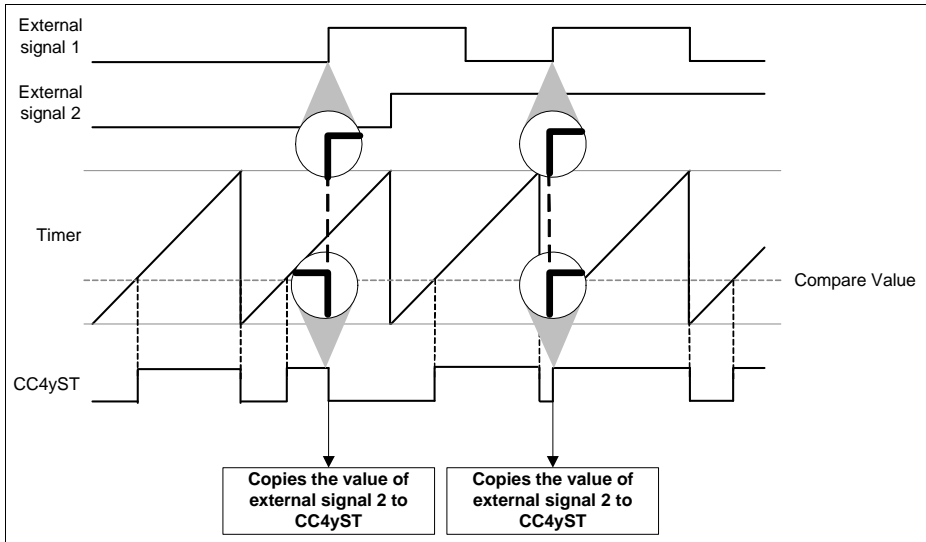


Figure 19-39 Status bit override

## 19.2.8 Multi-Channel Control

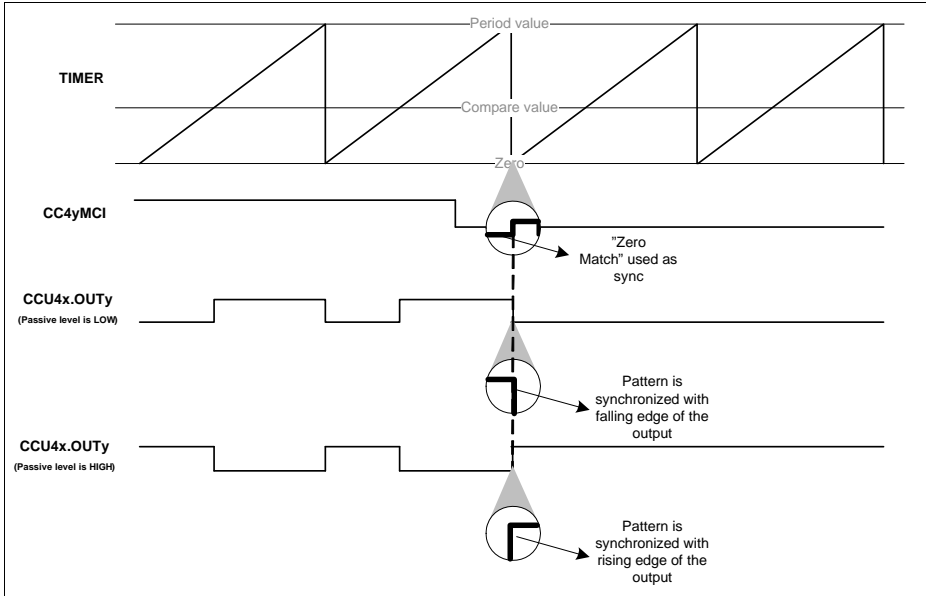
The multi channel control mode is selected individually in each slice by setting the **CC4yTC.MCME** = 1<sub>B</sub>.

Within this mode, the output state of the Timer Slices (the ones set in multi channel mode) can be controlled in parallel by a single pattern.

The pattern is controlled via the CCU4 inputs, CCU4x.MCI0, CCU4x.MCI1, CCU4x.MCI2 and CCU4x.MCI3. Each of these inputs is connected directly to the associated slice input, e.g. CCU4x.MCI0 to CC40MCI, CCU4x.MCI1 to CC41MCI.

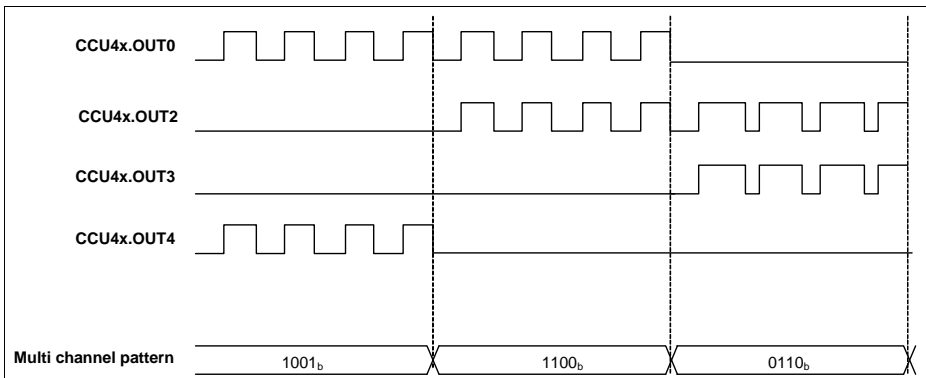
This pattern can be controlled directly by other module. The connectivity of each device may allow different control possibilities therefore one should address [Section 19.8](#) to check what modules are connected to these inputs.

When using the Multi Channel support of the CCU4, one can achieve a complete synchronicity between the output state update, CCU4x.OUTy, and the update of a new pattern, [Figure 19-40](#). This synchronicity feature can be enabled by using some specific modules and therefore one should address [Section 19.8](#) to check which module is controlling the CCU4x.MCIy inputs.



**Figure 19-40 Multi channel pattern synchronization**

**Figure 19-41** shows the usage of the multi channel mode in conjunction with all four Timer Slices inside the CCU4.



**Figure 19-41 Multi Channel mode for multiple Timer Slices**

The synchronization between the CCU4 and the module controlling the multi-channel pattern is achieved, by adding a 3 cycle delay on the output path of each Timer Slice

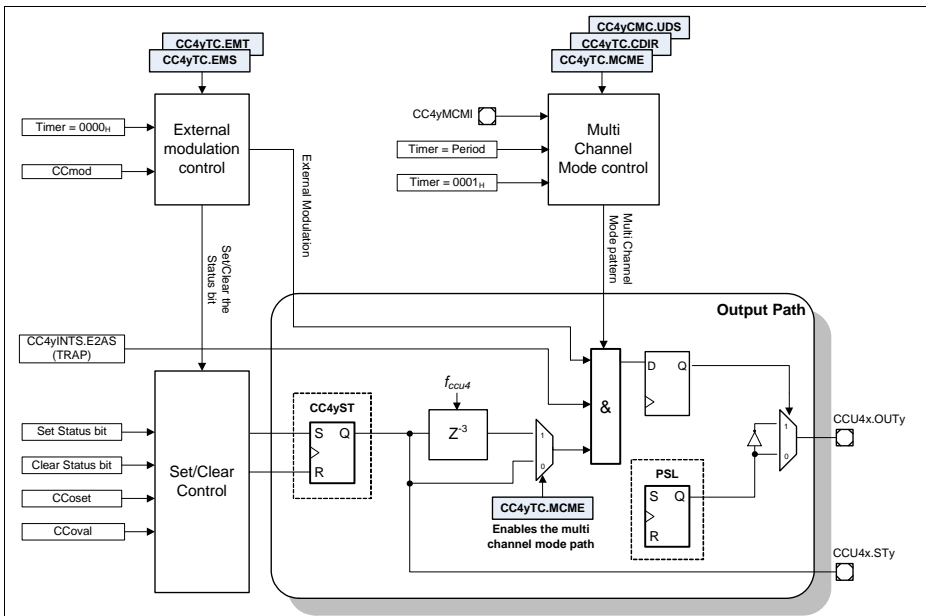
**Capture/Compare Unit 4 (CCU4)**

(between the status bit, CC4yST and the direct control of the output pin). This path is only selected when **CC4yINS.MCME** = 1<sub>B</sub>, see **Figure 19-42**.

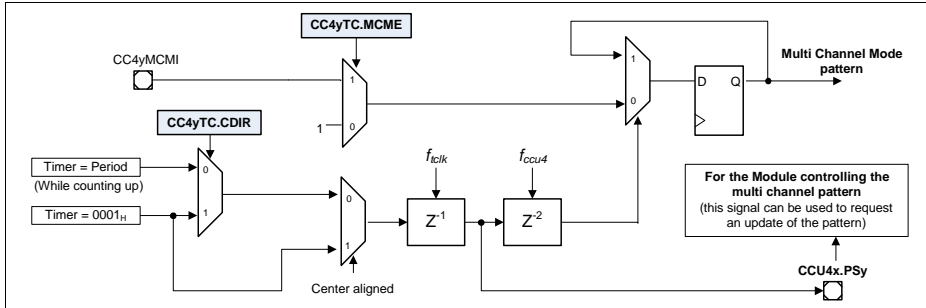
The multi pattern input synchronization can be seen on **Figure 19-43**. To achieve a synchronization between the update of the status bit, the sampling of a new multi channel pattern input is controlled by the period match or one match signal.

In a straightforward utilization of this synchronization feature, the module controlling the multi channel pattern signals, receives a sync signal from the CCU4, the CCU4x.PSy. This signal is then used by this module to update the multi-channel pattern. Due to the structure of the synchronization scheme inside the CCU4, the module controlling the multi-channel pattern needs to update this pattern, within 4 clock cycles after the CCU4x.PSy signal is asserted, **Figure 19-43**.

In a normal operation, where no external signal is used to control the counting direction, the signal used to enable the sampling of the pattern is always the period match when in edge aligned and the one match when in center aligned mode. When an external signal is used to control the counting direction, depending if the counter is counting up or counting down, the period match or the one match signal is used, respectively.



**Figure 19-42 CC4y Status bit and Output Path**



**Figure 19-43 Multi Channel Mode Control Logic**

### 19.2.9 Timer Concatenation

The CCU4 offers a very easy mechanism to perform a synchronous timer concatenation. This functionality can be used by setting the **CC4yTC.TCE** =  $1_B$ . By doing this the user is doing a concatenation of the actual CCU4 slice with the previous one, see [Figure 19-44](#).

Notice that it is not possible to perform concatenation with non adjacent slices and that timer concatenation automatically sets the slice mode into Edge Aligned. It is not possible to perform timer concatenation in Center Aligned mode.

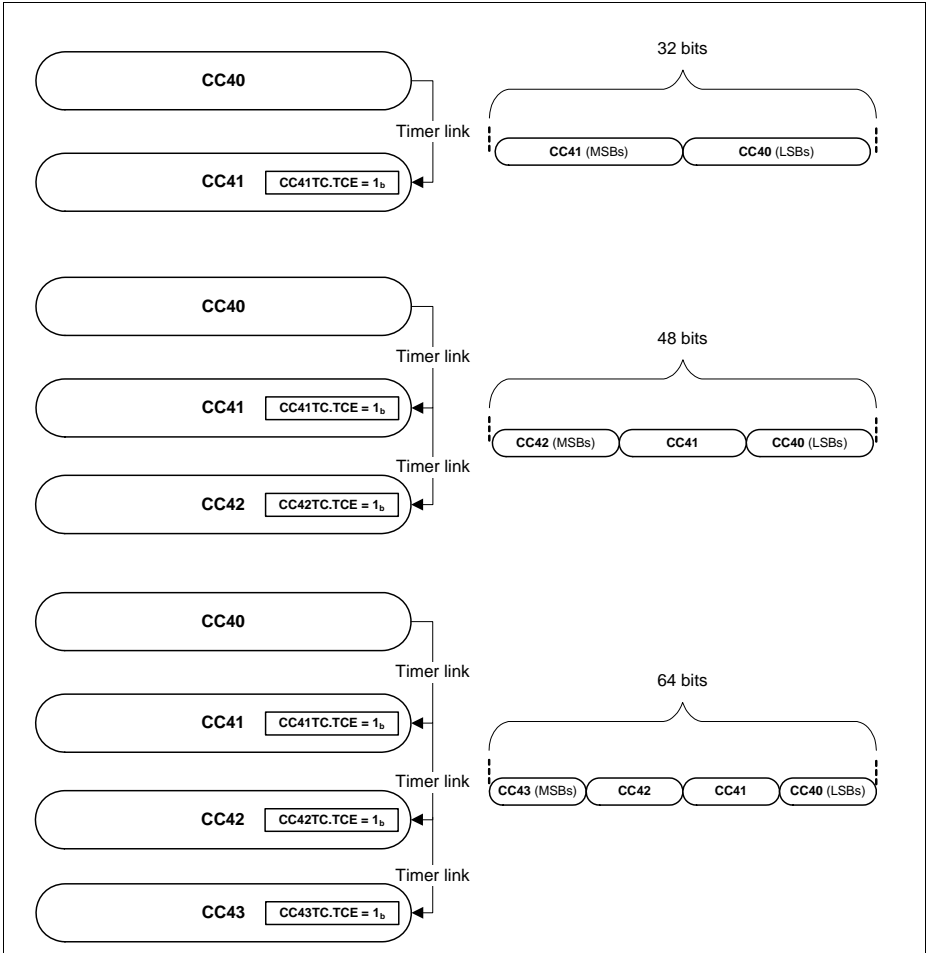
To enable a 64 bit timer, one should set the **CC4yTC.TCE** =  $1_B$  in all the slices (with the exception of the CC40 due to the fact that it doesn't contain this control register).

To enable a 48 bit timer, one should set the **CC4yTC.TCE** =  $1_B$  in two adjacent slices and to enable a 32 bit timer, the **CC4yTC.TCE** is set to  $1_B$  in the slice containing the MSBs. Notice that the timer slice containing the LSBs should always have the TCE bitfield set to  $0_B$ .

Several combinations for timer concatenation can be made inside a CCU4 module:

- one 64 bit timer
- one 48 bit timer plus a 16 timer
- two 32 bit timers
- one 32 bit timer plus two 16 bit timers

**Capture/Compare Unit 4 (CCU4)**



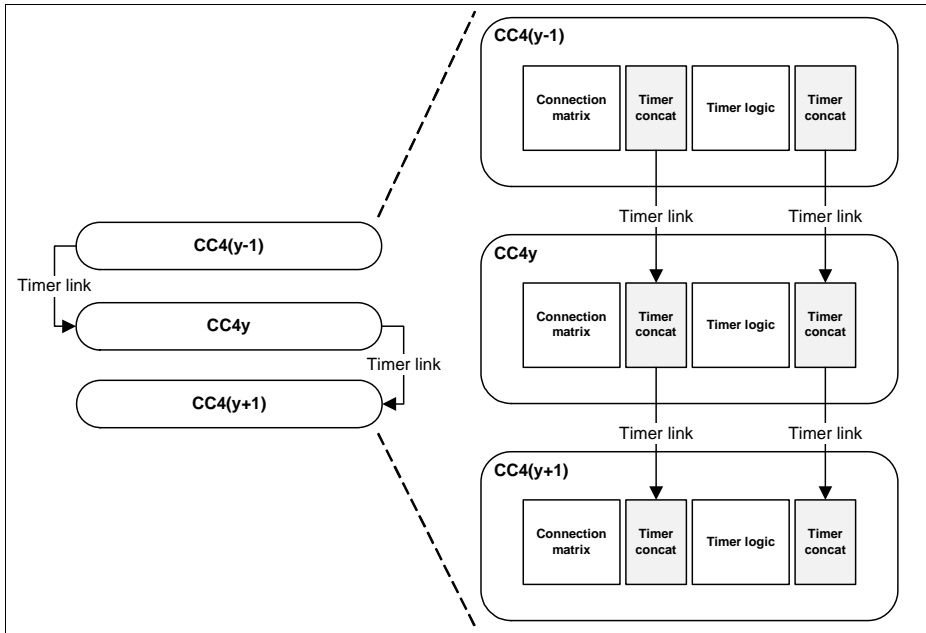
**Figure 19-44 Timer Concatenation Example**

Each Timer Slice is connected to the adjacent Timer Slices via a dedicated concatenation interface. This interface allows the concatenation of not only the Timer counting operation, but also a synchronous input trigger handling for capturing and loading operations, [Figure 19-45](#).

*Note: For all cases CC40 and CC43 are not considered adjacent slices*



**Capture/Compare Unit 4 (CCU4)**



**Figure 19-45 Timer Concatenation Link**

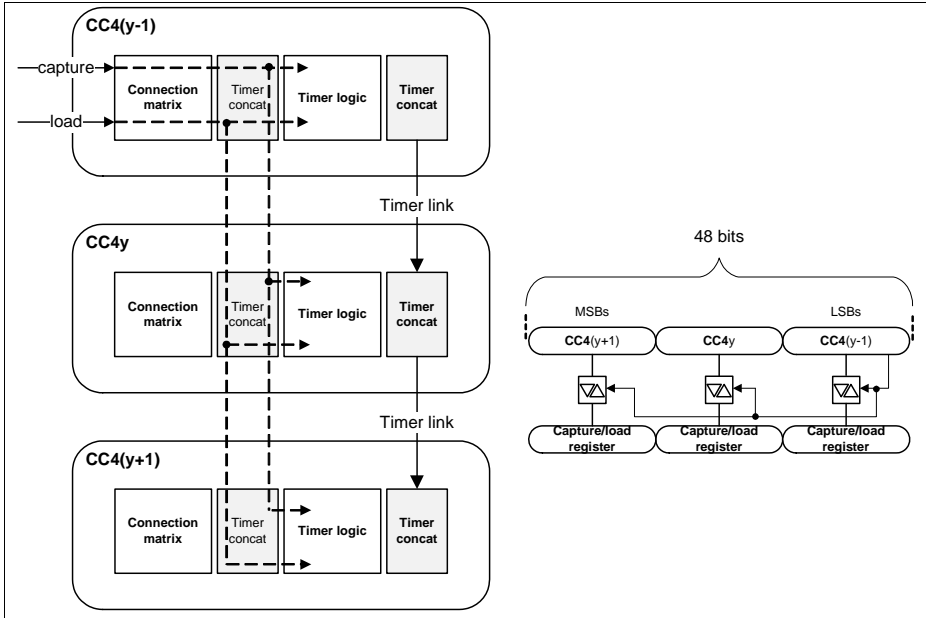
Seven signals are present in the timer concatenation interface:

- Timer Period match (CC4yPM)
- Timer Zero match (CC4yZM)
- Timer Compare match (CC4yCM)
- Timer counting direction function (CCupd)
- Timer load function (CCload)
- Timer capture function for CC4yC0V and CC4yC1V registers (CCcap0)
- Timer capture function for CC4yC2V and CC4yC3V registers (CCcap1)

The first four signals are used to perform the synchronous timing concatenation at the output of the Timer Logic, like it is seen in [Figure 19-45](#). With this link, the timer length can be easily adjusted to 32, 48 or 64 bits (counting up or counting down).

The last three signals are used to perform a synchronous link between the capture and load functions, for the concatenated timer system. This means that the user can have a capture or load function programmed in the first Timer Slice, and propagate this capture or load trigger synchronously from the LSBs until the MSBs, [Figure 19-46](#).

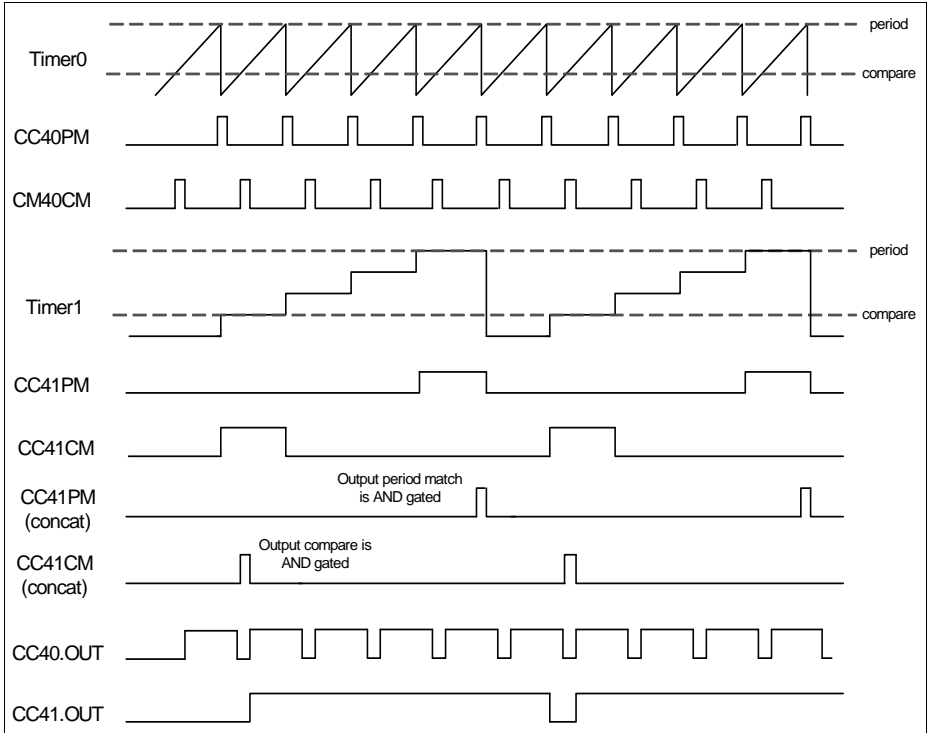
The capture or load function only needs to be configured in the first Timer Slice (the one holding the LSBs). From the moment that **CC4yTC.TCE** is set to 1<sub>B</sub>, in the following Timer Slices, the link between these functions is done automatically by the hardware.



**Figure 19-46 Capture/Load Timer Concatenation**

The period match ( $CC4yPM$ ) or zero match ( $CC4yZM$ ) from the previous Timer Slice (with the immediately next lower index) are used in concatenated mode, as gating signal for the counter. This means that the counting operation of the MSBs only happens when a wrap around condition is detected, avoiding additional DSP operations to extract the counting value.

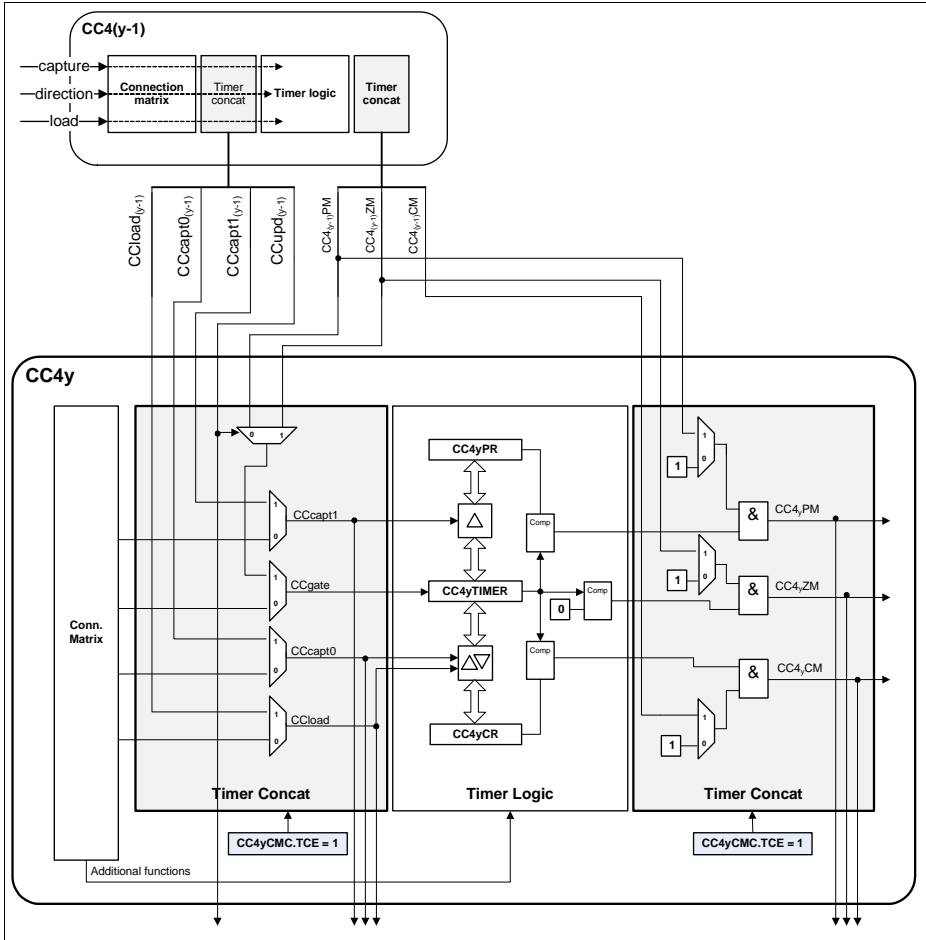
With the same methodology, the compare match ( $CC4yCM$ ), zero match and period match are gated with the specific signals from the previous slice. This means that the timing information is propagated throughout all the slices, enabling a completely synchronous match between the LSB and MSB count, see [Figure 19-47](#).



**Figure 19-47 32 bit concatenation timing diagram**

*Note: The counting direction of the concatenated timer needs to be fixed. The timer can count up or count down, but the direction cannot be updated on the fly.*

**Figure 19-48** gives an overview of the timer concatenation logic. Notice that all the mechanism is controlled solely by the **CC4yTC**.TCE bitfield.



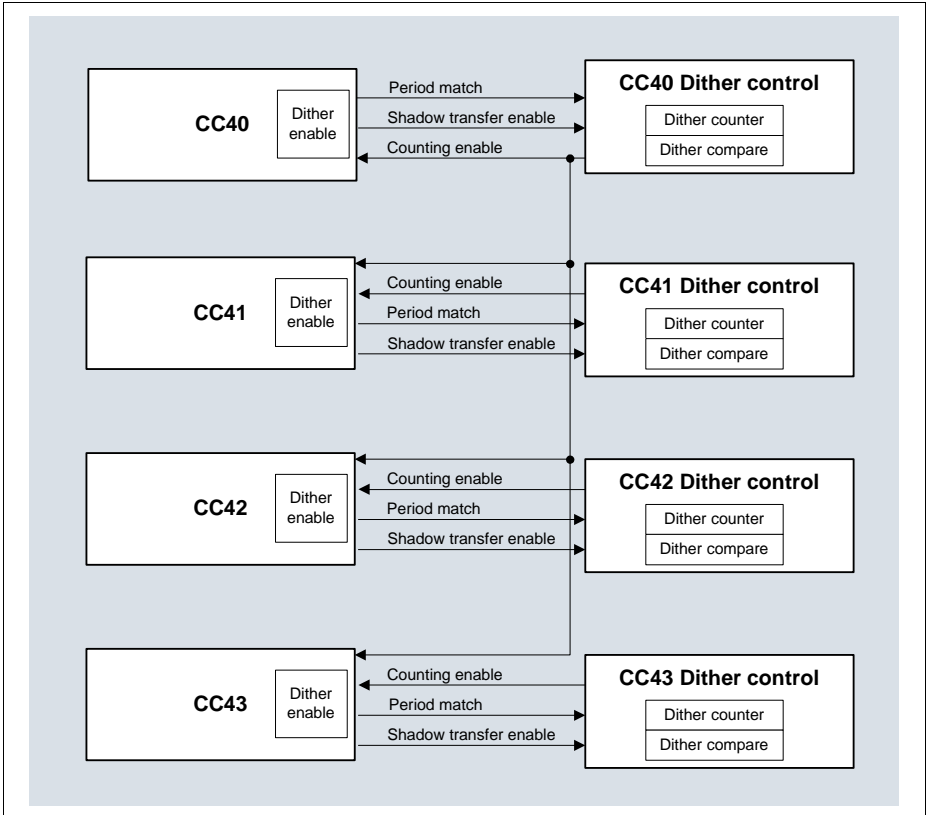
**Figure 19-48** Timer concatenation control logic

### 19.2.10 PWM Dithering

The CCU4 has an automatic PWM dithering insertion function. This functionality can be used with very slow control loops that cannot update the period/compare values in a fast manner, and by that fact the loop can lose precision on long runs. By introducing dither on the PWM signal, the average frequency/duty cycle is then compensated against that error.

Each slice contains a dither control unit, see [Figure 19-49](#).

Capture/Compare Unit 4 (CCU4)



**Figure 19-49 Dither structure overview**

The dither control unit contains a 4 bit counter and a compare value. The four bit counter is incremented every time that a period match occurs. The counter works in a bit reverse mode so the distribution of increments stays uniform over 16 counter periods, see [Table 19-5](#).

**Table 19-5 Dither bit reverse counter**

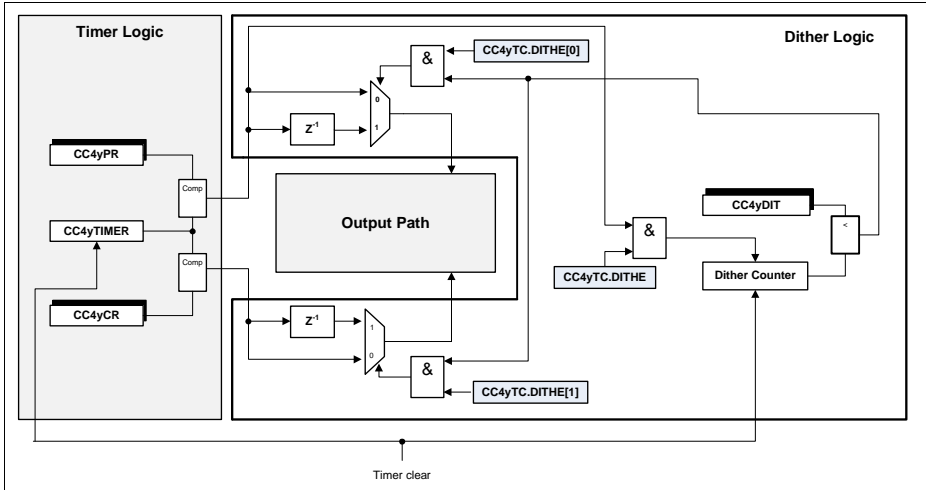
counter[3]	counter[2]	counter[1]	counter[0]
0	0	0	0
1	0	0	0
0	1	0	0
1	1	0	0
0	0	1	0
1	0	1	0
0	1	1	0
1	1	1	0
0	0	0	1
1	0	0	1
0	1	0	1
1	1	0	1
0	0	1	1
1	0	1	1
0	1	1	1
1	1	1	1

The counter is then compared against a programmed value, **CC4yDIT.DCV**. If the counter value is smaller than the programmed value, a gating signal is generated that can be used to extend the period, to delay the compare or both (controlled by the **CC4yTC.DITHE** field, see [Table 19-6](#)) for one clock cycle.

**Table 19-6 Dither modes**

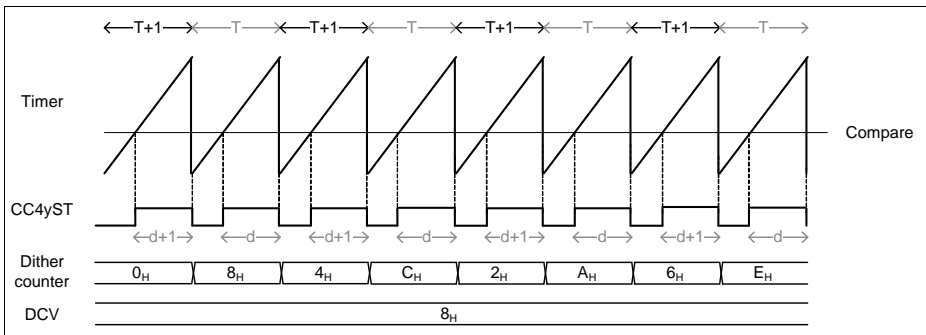
DITHE[1]	DITH[0]	Mode
0	0	Dither is disabled
0	1	Period is increased by 1 cycle
1	0	Compare match is delayed by 1 cycle
1	1	Period is increased by 1 cycle and compare is delayed by 1 cycle

The dither compare value also has an associated shadow register that enables concurrent update with the period/compare register of CC4y. The control logic for the dithering unit is represented on [Figure 19-50](#).



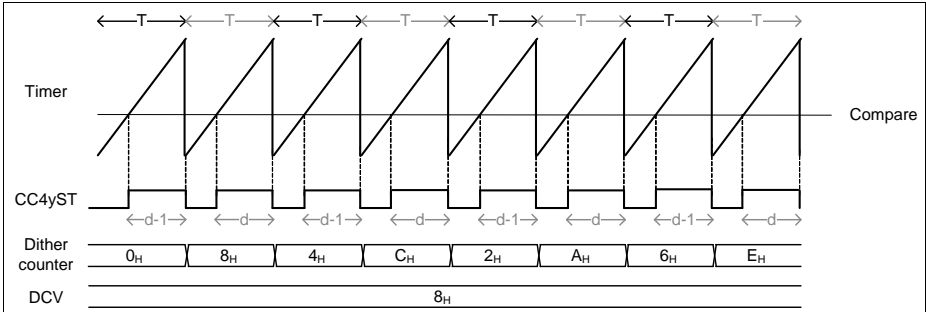
**Figure 19-50 Dither control logic**

**Figure 19-51** to **Figure 19-56** show the effect of the different configurations for the dithering function, **CC4yTC.DITHE**, for both counting schemes, Edge and Center Aligned mode. In each figure, the bit reverse scheme is represented for the dither counter and the compare value was programmed with the value  $8_H$ . In each figure, the variable  $T$ , represents the period of the counter, while the variable  $d$  indicates the duty cycle (status bit is set HIGH).

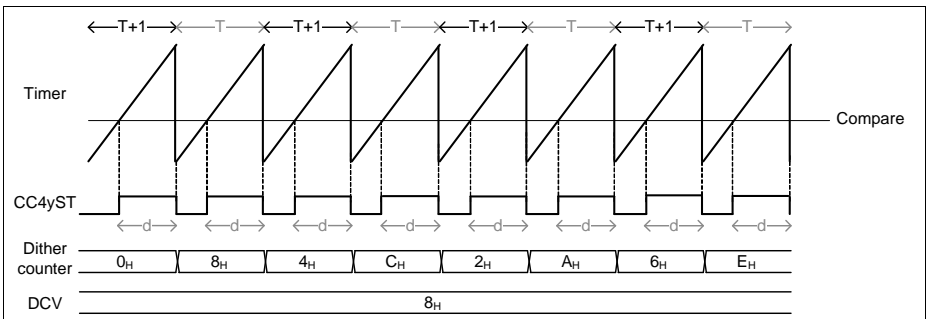


**Figure 19-51 Dither timing diagram in edge aligned - **CC4yTC.DITHE** = 01<sub>B</sub>**

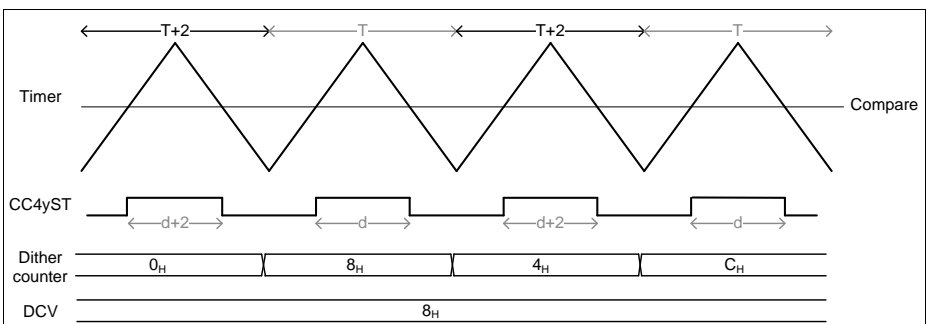
**Capture/Compare Unit 4 (CCU4)**



**Figure 19-52 Dither timing diagram in edge aligned -  $CC4yTC.DITHE = 10_B$**



**Figure 19-53 Dither timing diagram in edge aligned -  $CC4yTC.DITHE = 11_B$**



**Figure 19-54 Dither timing diagram in center aligned -  $CC4yTC.DITHE = 01_B$**



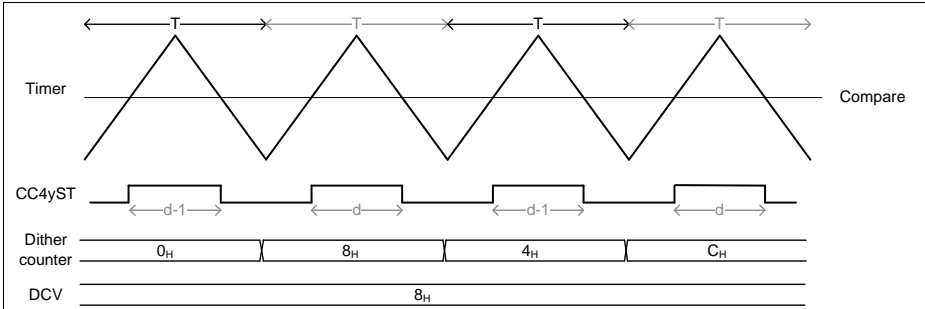


Figure 19-55 Dither timing diagram in center aligned - **CC4yTC.DITHE = 10<sub>B</sub>**

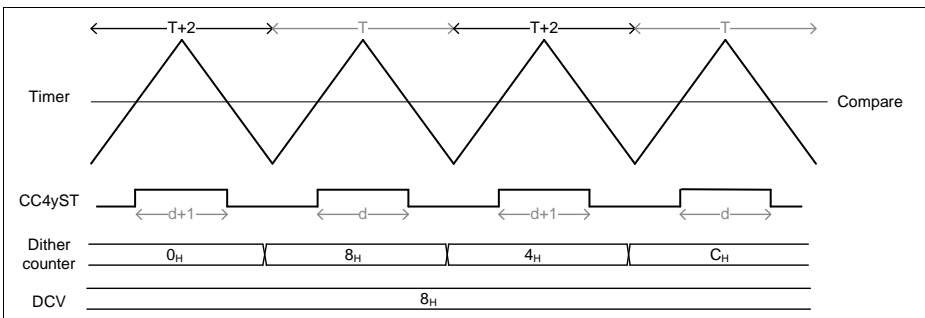


Figure 19-56 Dither timing diagram in center aligned - **CC4yTC.DITHE = 11<sub>B</sub>**

*Note: When using the dither, is not possible to select a period value of FS when in edge aligned mode. In center aligned mode, the period value must be at least FS - 2.*

### 19.2.11 Prescaler

The CCU4 contains a 4 bit prescaler that can be used in two operating modes for each individual slice:

- normal prescaler mode
- floating prescaler mode

The run bit of the prescaler can be set/cleared by SW by writing into the registers, **GIDLC.SPRB** and **GIDLS.CPRB** respectively, and it can also be cleared by the run bit of a specific slice. With the last mechanism, the run bit of the prescaler is cleared one clock cycle after the clear of the run bit of the selected slice. To select which slice can perform this action, one should program the **GCTRL.PRBC** register.

### 19.2.11.1 Normal Prescaler Mode

In Normal prescaler mode the clock fed to the CC4y counter is a normal fixed division by N, accordingly to the value set in the **CC4yPSC**.PSIV register. The values for the possible division values are listed in **Table 19-7**. The **CC4yPSC**.PSIV value is only modified by a SW access. Notice that each slice has a dedicated prescaler value selector (**CC4yPSC**.PSIV), which means that the user can select different counter clocks for each Timer Slice (CC4y).

**Table 19-7 Timer clock division options**

<b>CC4yPSC</b> .PSIV	Resulting clock
0000 <sub>B</sub>	$f_{CCU4}$
0001 <sub>B</sub>	$f_{CCU4}/2$
0010 <sub>B</sub>	$f_{CCU4}/4$
0011 <sub>B</sub>	$f_{CCU4}/8$
0100 <sub>B</sub>	$f_{CCU4}/16$
0101 <sub>B</sub>	$f_{CCU4}/32$
0110 <sub>B</sub>	$f_{CCU4}/64$
0111 <sub>B</sub>	$f_{CCU4}/128$
1000 <sub>B</sub>	$f_{CCU4}/256$
1001 <sub>B</sub>	$f_{CCU4}/512$
1010 <sub>B</sub>	$f_{CCU4}/1024$
1011 <sub>B</sub>	$f_{CCU4}/2048$
1100 <sub>B</sub>	$f_{CCU4}/4096$
1101 <sub>B</sub>	$f_{CCU4}/8192$
1110 <sub>B</sub>	$f_{CCU4}/16384$
1111 <sub>B</sub>	$f_{CCU4}/32768$

### 19.2.11.2 Floating Prescaler Mode

The floating prescaler mode can be used individually in each slice by setting the register **CC4yTC**.FPE = 1<sub>B</sub>. With this mode, the user can not only achieve a better precision on the counter clock for compare operations but also reduce the SW read access for the capture mode.

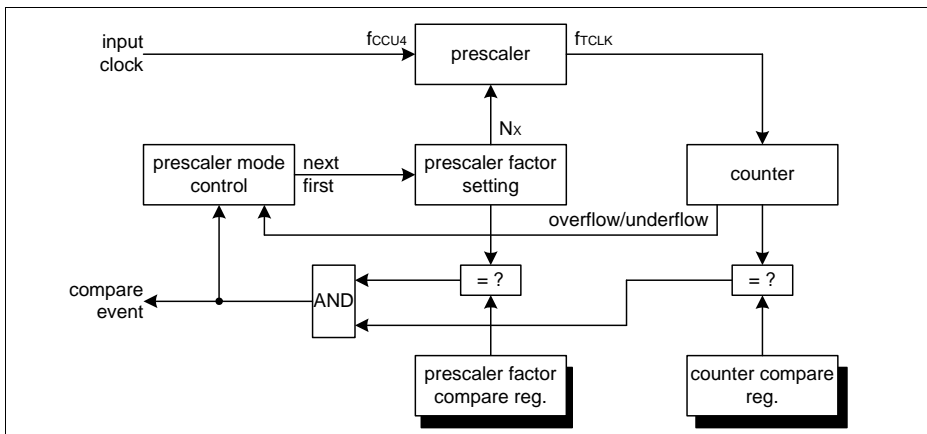
The floating prescaler mode contains additionally to the initial configuration value register, **CC4yPSC**.PSIV, a compare register, **CC4yFPC**.PCMP with an associated shadow register mechanism.

**Capture/Compare Unit 4 (CCU4)**

**Figure 19-57** shows the structure of the prescaler in floating mode when the specific slice is in compare mode (no external signal is used for capture). In this mode, the value of the clock division is incremented by  $1_D$  every time that a timer overflow/underflow (overflow if in Edge Aligned Mode, underflow if in Center Aligned Mode) occurs.

In this mode, the Compare Match from the timer is AND with the Compare Match of the prescaler and every time that this event occurs, the value of the clock division is updated with the **CC4yPSC.PSIV** value in the immediately next timer overflow/underflow event.

The shadow transfer of the floating prescaler compare value, **CC4yFPC.PCMP**, is done following the same rules described on **Section 19.2.5.2**.

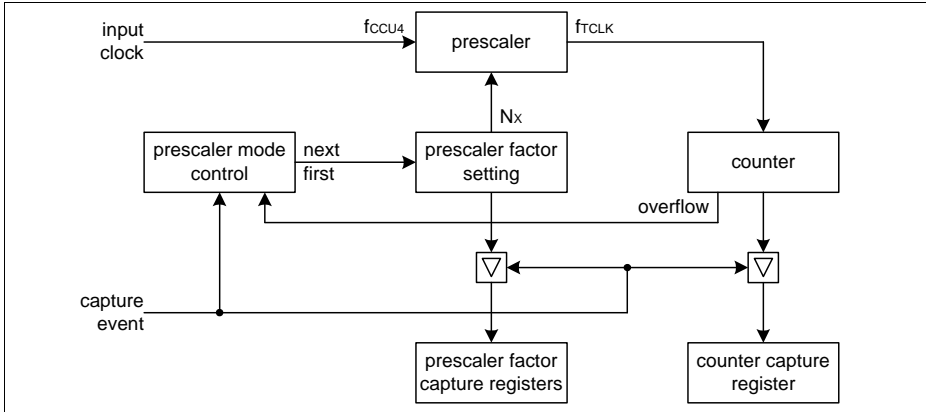


**Figure 19-57 Floating prescaler in compare mode overview**

When the specific CC4y is operating in capture mode (when at least one external signal is decoded as capture functionality), the actual value of the clock division also needs to be stored every time that a capture event occurs. The floating prescaler can have up to 4 capture registers (the maximum number of capture registers is dictated by the number of capture registers used in the specific slice).

The clock division value continues to be incremented by  $1_D$  every time that a timer overflow (in capture mode, the slice is always operating in Edge Aligned Mode) occurs and it is loaded with the PSIV value every time that a capture triggers is detected.

See the **Section 19.2.12.2** for a full description of the usage of the floating prescaler mode in conjunction with compare and capture modes.



**Figure 19-58 Floating Prescaler in capture mode overview**

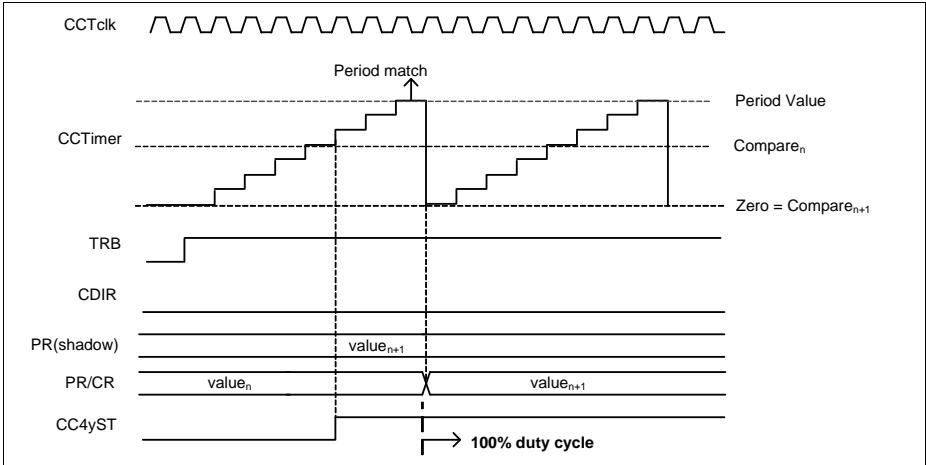
## 19.2.12 CCU4 Usage

### 19.2.12.1 PWM Signal Generation

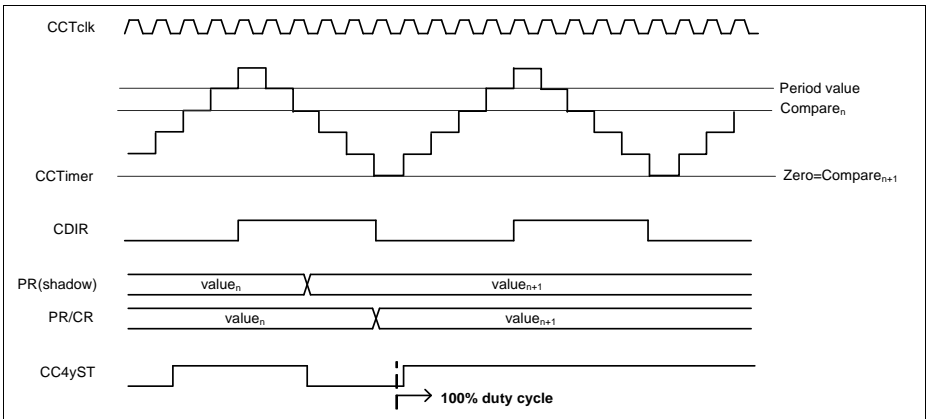
The CCU4 offers a very flexible range in duty cycle configurations. This range is comprised between 0 to 100%.

To generate a PWM signal with a 100% duty cycle in Edge Aligned Mode, one should program the compare value, **CC4yCR.CR**, to 0000<sub>H</sub>, see [Figure 19-59](#).

In the same manner a 100% duty cycle signal can be generated in Center Aligned Mode, see [Figure 19-60](#).



**Figure 19-59 PWM with 100% duty cycle - Edge Aligned Mode**



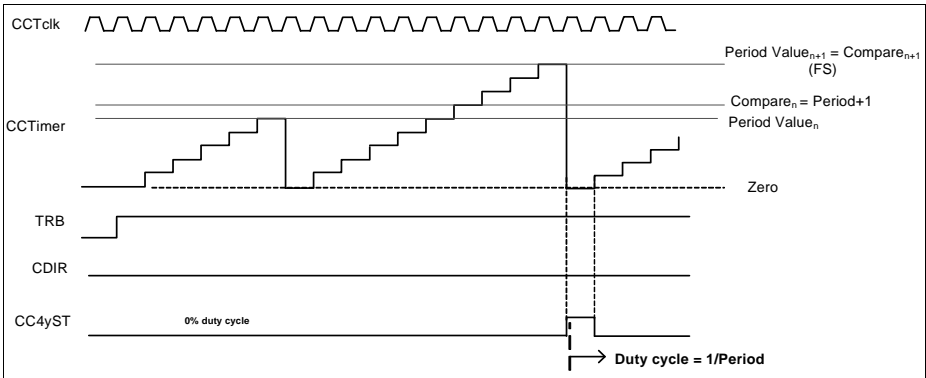
**Figure 19-60 PWM with 100% duty cycle - Center Aligned Mode**

To generate a PWM signal with 0% duty cycle in Edge Aligned Mode, the compare register should be set with the value programmed into the period value plus 1. In the case that the timer is being used with the full 16 bit capability (counting from 0 to 65535), setting a value bigger than the period value into the compare register is not possible and therefore the smallest duty cycle that can be achieved is 1/FS, see [Figure 19-61](#).

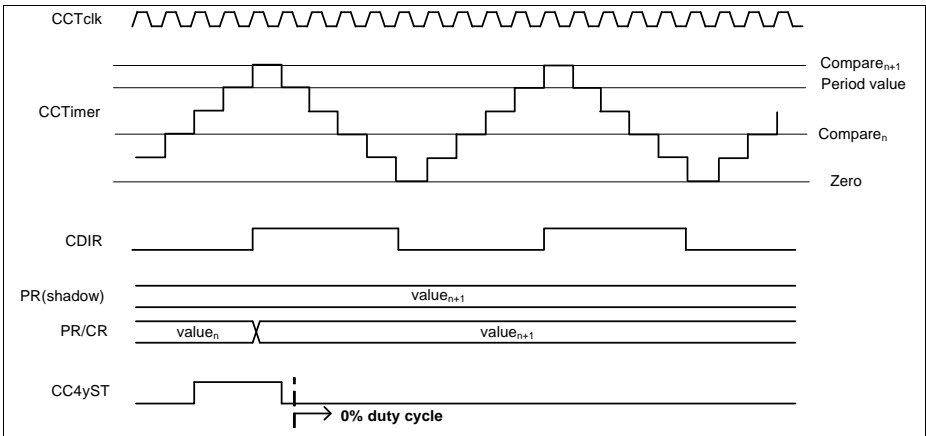
In Center Aligned Mode, the counter is never running from 0 to 65535<sub>D</sub>, due to the fact that it has to overshoot for one clock cycle the value set in the period register. Therefore the user never has a FS counter, which means that generating a 0% duty cycle signal is

**Capture/Compare Unit 4 (CCU4)**

always possible by setting a value in the compare register bigger than the one programmed into the period register, see [Figure 19-62](#).



**Figure 19-61 PWM with 0% duty cycle - Edge Aligned Mode**



**Figure 19-62 PWM with 0% duty cycle - Center Aligned Mode**

**19.2.12.2 Prescaler Usage**

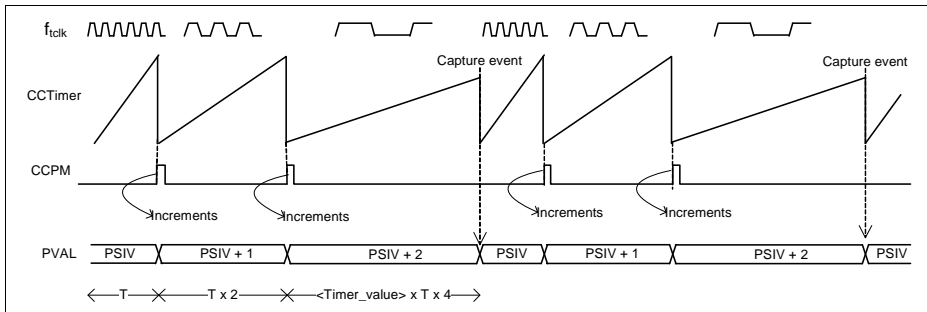
In Normal Prescaler Mode, the frequency of the  $f_{clk}$  fed to the specific CC4y is chosen from the [Table 19-7](#), by setting the [CC4yPSC.PSIV](#) with the required value.

In Floating Prescaler Mode, the frequency of the  $f_{clk}$  can be modified over a selected timeframe, within the values specified in [Table 19-7](#). This mechanism is specially useful if, when in capture mode, the dynamic of the capture triggers is very slow or unknown.

**Capture/Compare Unit 4 (CCU4)**

In Capture Mode, the Floating Prescaler value is incremented by 1 every time that a timer overflow happens and it is set with the initial programmed value when a capture event happens, see **Figure 19-63**.

When using the Floating Prescaler Mode in Capture Mode, the timer should be cleared each time that a capture event happens, **CC4yTC.CAPC** = 11<sub>B</sub>. By operating the Capture mode in conjunction with the Floating Prescaler, even for capture signals that have a periodicity bigger than 16 bits, it is possible to use just a single CCU4 Timer Slice without monitoring the interrupt event of the timer overflow, cycle by cycle. For this the user just needs to know what is the timer captured value and the actual prescaler configuration at the time that the capture event occurred. These values are contained in each CC4yCxV register.



**Figure 19-63 Floating Prescaler capture mode usage**

When in Compare Mode, the Floating Prescaler function may be used to achieve a fractional PWM frequency or to perform some frequency modulation.

The same incrementing by 1<sub>D</sub> mechanism is done every time that an overflow/underflow of the Timer occurs and the actual Prescaler value, doesn't match the one programmed into the **CC4yFPC.PCMP** register.

When a Compare Match from the Timer occurs and the actual Prescaler value is equal to the one programmed on the **CC4yFPC.PCMP** register, then the Prescaler value is set with the initial value, **CC4yPSC.PSIV**, when the next occurrence of a timer overflow/underflow.

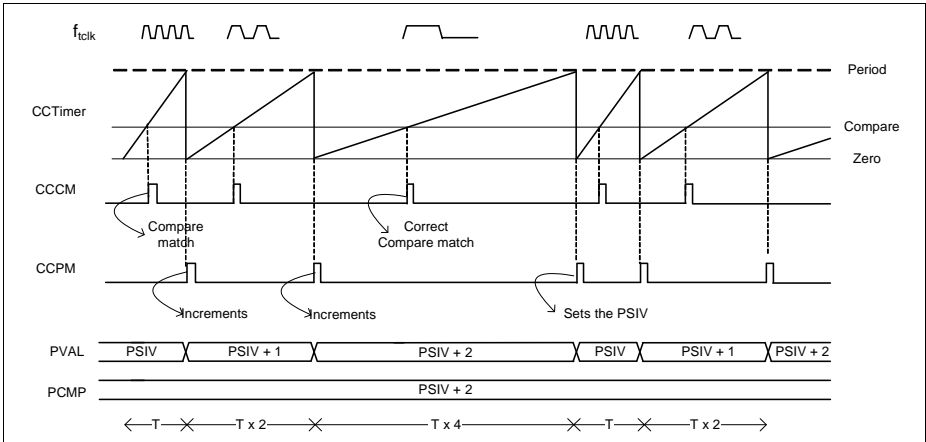
In **Figure 19-64**, the Compare value of the Floating Prescaler was set to PSIV + 2. Every time that a timer overflow occurs, the value of the Prescaler is incremented by 1, which means that if we give  $f_{tclk}$  as the reference frequency for the **CC4yPSC.PSIV** value, we have  $f_{tclk}/2$  for **CC4yPSC.PSIV + 1** and  $f_{tclk}/4$  for **CC4yPSC.PSIV + 2**.

The period over time of the counter becomes:

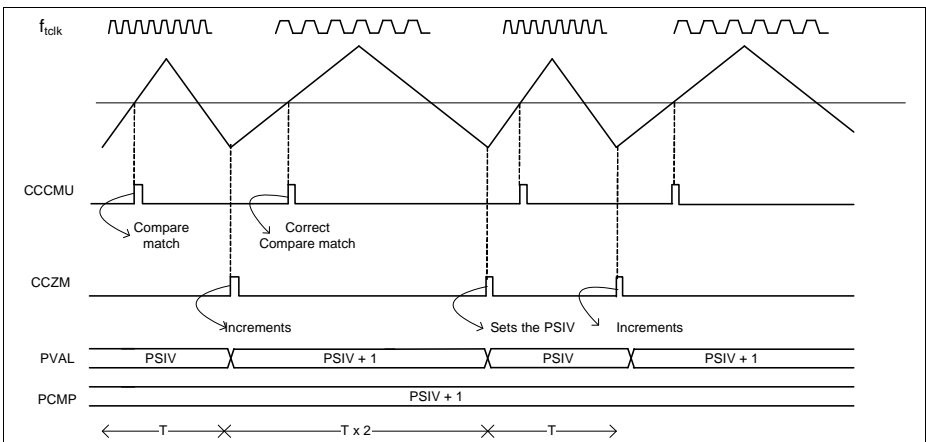
$$Period = (1/f_{tclk} + 2/f_{tclk} + 4/f_{tclk}) / 3 \quad (19.10)$$

**Capture/Compare Unit 4 (CCU4)**

The same mechanism is used in Center Aligned Mode, but to keep the rising arcade and falling arcade always symmetrical, instead of the overflow of the timer, the underflow is used, see [Figure 19-65](#).



**Figure 19-64 Floating Prescaler compare mode usage - Edge Aligned**



**Figure 19-65 Floating Prescaler compare mode usage - Center Aligned**

**19.2.12.3 PWM Dither**

The Dither functionality can be used to achieve a very fine precision on the periodicity of the output state in compare mode. The value set in the dither compare register, **CC4yDIT.DCV** is crosschecked against the actual value of the dither counter and every



**Capture/Compare Unit 4 (CCU4)**

time that the dither counter is smaller than the comparison value one of the follows actions is taken:

- The period is extended for 1 clock cycle - **CC4yTC.DITHE** = 01<sub>B</sub>; in edge aligned mode
- The period is extended for 2 clock cycles - **CC4yTC.DITHE** = 01<sub>B</sub>; in center aligned mode
- The comparison match while counting up (**CC4yTCST.CDIR** = 0<sub>B</sub>) is delayed (this means that the status bit is going to stay in the SET state 1 cycle less) for 1 clock cycle - **CC4yTC.DITHE** = 10<sub>B</sub>;
- The period is extended for 1 clock cycle and the comparison match while counting up is delayed for 1 clock cycle - **CC4yTC.DITHE** = 11<sub>B</sub>; in edge aligned mode
- The period is extended for 2 clock cycles and the comparison match while counting up is delayed for 1 clock cycle; center aligned mode

The bit reverse counter distributes the number programmed in the **CC4yDIT.DCV** throughout a window of 16 timer periods.

**Table 19-8** describes the bit reverse distribution versus the programmed value on the **CC4yDIT.DCV** field. The fields marked as '0' indicate that in that counter period, one of the above described actions, is going to be performed.

**Table 19-8 Bit reverse distribution**

Dither counter	DCV															
	0	1	2	3	4	5	6	7	8	9	10	11	12	13	14	15
0	1	0	0	0	0	0	0	0	0	0	0	0	0	0	0	0
8	1	1	1	1	1	1	1	1	1	0	0	0	0	0	0	0
4	1	1	1	1	1	0	0	0	0	0	0	0	0	0	0	0
C	1	1	1	1	1	1	1	1	1	1	1	1	1	0	0	0
2	1	1	1	0	0	0	0	0	0	0	0	0	0	0	0	0
A	1	1	1	1	1	1	1	1	1	1	1	0	0	0	0	0
6	1	1	1	1	1	1	1	0	0	0	0	0	0	0	0	0
E	1	1	1	1	1	1	1	1	1	1	1	1	1	1	1	0
1	1	1	0	0	0	0	0	0	0	0	0	0	0	0	0	0
9	1	1	1	1	1	1	1	1	1	1	0	0	0	0	0	0
5	1	1	1	1	1	1	0	0	0	0	0	0	0	0	0	0
D	1	1	1	1	1	1	1	1	1	1	1	1	1	1	0	0
3	1	1	1	1	0	0	0	0	0	0	0	0	0	0	0	0
B	1	1	1	1	1	1	1	1	1	1	1	1	0	0	0	0

**Table 19-8 Bit reverse distribution (cont'd)**

Dither counter	DCV															
	0	1	2	3	4	5	6	7	8	9	10	11	12	13	14	15
7	1	1	1	1	1	1	1	1	0	0	0	0	0	0	0	0
F	1	1	1	1	1	1	1	1	1	1	1	1	1	1	1	1

The bit reverse distribution versus the programmed **CC4yDIT.DCV** value results in the following values for the Period and duty cycle:

**DITHE = 01<sub>B</sub>**

$$Period = [(16 - DCV) \times T + DCV \times (T + 1)]/16; \text{ in Edge Aligned Mode} \quad (19.11)$$

$$Duty\ cycle = [(16 - DCV) \times d/T + DCV \times (d+1)/(T + 1)]/16; \text{ in Edge Aligned Mode} \quad (19.12)$$

$$Period = [(16 - DCV) \times T + DCV \times (T + 2)]/16; \text{ in Center Aligned Mode} \quad (19.13)$$

$$Duty\ cycle = [(16 - DCV) \times d/T + DCV \times (d+2)/(T + 2)]/16; \text{ in Center Aligned Mode} \quad (19.14)$$

**DITHE = 10<sub>B</sub>**

$$Period = T; \text{ in Edge Aligned Mode} \quad (19.15)$$

$$Duty\ cycle = [(16 - DCV) \times d/T + DCV \times (d-1)/T]/16; \text{ in Edge Aligned Mode} \quad (19.16)$$

$$Period = T; \text{ in Center Aligned Mode} \quad (19.17)$$

$$Duty\ cycle = [(16 - DCV) \times d/T + DCV \times (d-1)/T]/16; \text{ in Center Aligned Mode} \quad (19.18)$$

**DITHE = 11<sub>B</sub>**

$$Period = [(16 - DCV) \times T + DCV \times (T + 1)]/16; \text{ in Edge Aligned Mode} \quad (19.19)$$

$$Duty\ cycle = [(16 - DCV) \times d/T + DCV \times d/(T + 1)]/16; \text{ in Edge Aligned Mode} \quad (19.20)$$

$$Period = [(16 - DCV) \times T + DCV \times (T + 2)]/16; \text{ in Center Aligned Mode} \quad (19.21)$$

$$Duty\ cycle = [(16 - DCV) \times d/T + DCV \times (d+1)/(T + 2)]/16; \text{ in Center Aligned Mode} \quad (19.22)$$

where:

$T$  - Original period of the signal, see [Section 19.2.5.1](#)

$d$  - Original duty cycle of the signal, see [Section 19.2.5.1](#)

#### 19.2.12.4 Capture Mode Usage

Each Timer Slice can make use of 2 or 4 capture registers. Using only 2 capture registers means that only 1 Event was linked to a captured trigger. To use the four capture registers, both capture triggers need to be mapped into an Event (it can be the same signal with different edges selected or two different signals) or the **CC4yTC.SCE** field needs to be set to 1, which enables the linking of the 4 capture registers.

The internal slice mechanism for capturing is the same for the capture trigger 1 or capture trigger 0.

##### Different Capture Events - SCE = 0<sub>B</sub>

Capture trigger 1 (CCcapt1) is appointed to the capture register 2, **CC4yC2V** and capture register 3, **CC4yC3V**, while trigger 0 (CCcapt0) is appointed to capture register 1, **CC4yC1V** and 0, **CC4yC0V**.

In each CCcapt0 event, the timer value is stored into **CC4yC1V** and the value of the **CC4yC1V** is transferred into the **CC4yC0V**.

In each CCcapt1 event, the timer value is stored into capture register **CC4yC3V** and the value of the capture register **CC4yC3V** is transferred into **CC4yC2V**.

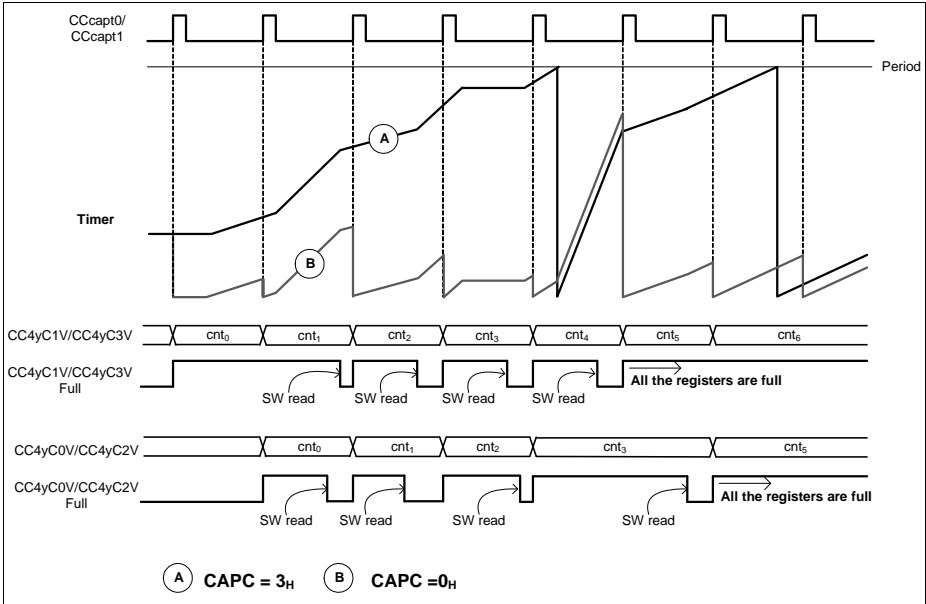
The capture/transfer mechanism only happens if the specific register is not full. A capture register becomes full when receives a new value and becomes empty after the SW has read back the value.

The full flag is cleared every time that the SW reads back the **CC4yC0V**, **CC4yC1V**, **CC4yC2V** or **CC4yC3V** register. The SW can be informed of a new capture trigger by enabling the interrupt source linked to the specific Event. This means that every time that a capture is made an interrupt pulse is generated.

In the case that the Floating Prescaler Mode is being used, the actual value of the clock division is also stored in the capture register (CC4yCxV).

**Figure 19-66** shows an example of how the capture/transfer may be used in a Timer Slice that is using an external signal as count function (to measure the velocity of a rotating device), and an equidistant capture trigger that is used to dictate the timestamp for the velocity calculation (two Timer waveforms are plotted, one that exemplifies the clearing of the timer in each capture event and another without the clearing function active).

**Capture/Compare Unit 4 (CCU4)**



**Figure 19-66 Capture mode usage - single channel**

**Same Capture Event - SCE = 1<sub>B</sub>**

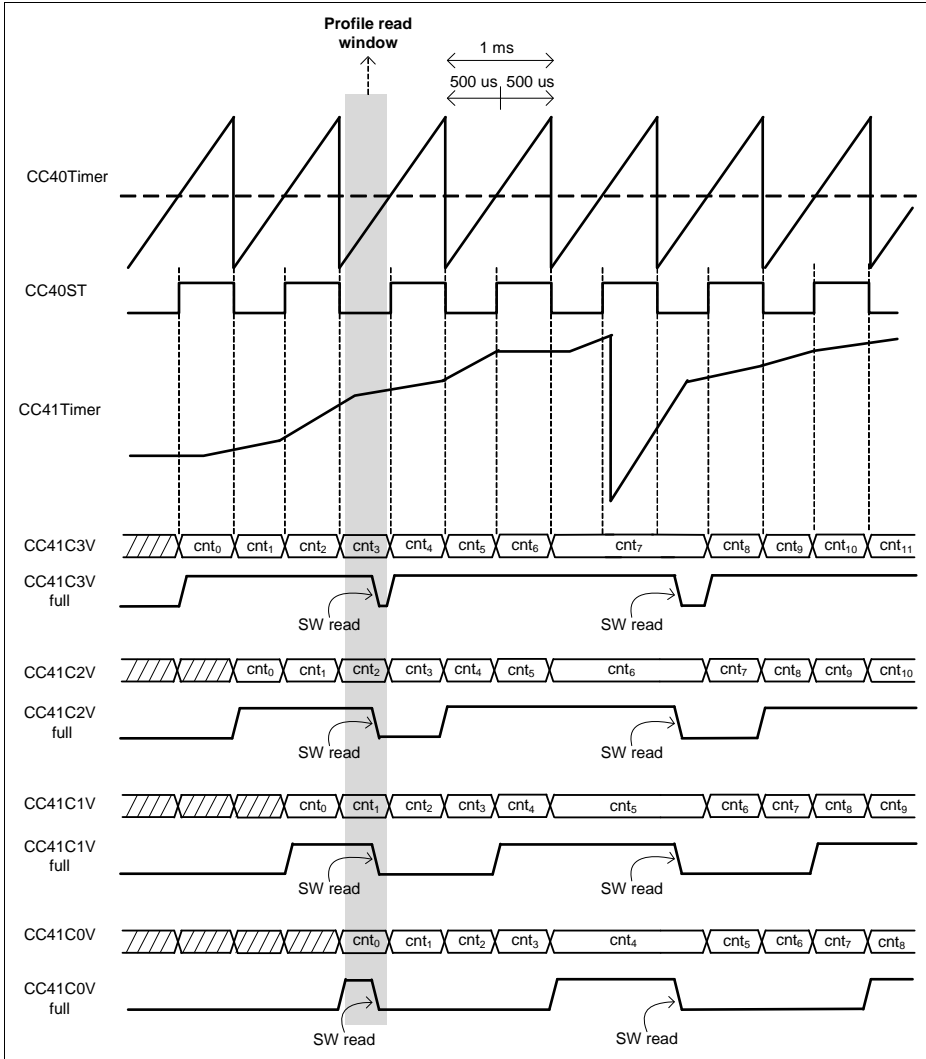
If the **CC4yTC.SCE** is set to 1<sub>B</sub>, all the four capture registers are chained together, emulating a fifo with a depth of 4. In this case, only the capture trigger 1, **CCcapt1**, is used to perform a capture event.

As an example for this mode, one can consider the case where one Timer Slice is being used in capture mode with SCE = 1<sub>B</sub>, with another external signal that controls the counting. This timer slice can be incremented at different speeds, depending on the frequency of the counting signal.

An additional Timer Slice is used to control the capture trigger, dictating the time stamp for the capturing.

A simple scheme for this can be seen in **Figure 19-67**. The **CC40ST** output of slice 0 was used as capture trigger in the **CC41** slice (active on rising and falling edge). The **CC40ST** output is used as known timebase marker, while the slice timer used for capture is being controlled by external events, e.g. external count.

Due to the fact that we have available 4 capture registers, every time that the SW reads back the complete set of values, 3 speed profiles can be measured.



**Figure 19-67 Three Capture profiles - CC4yTC.SCE = 1<sub>b</sub>**

To calculate the three different profiles in [Figure 19-67](#), the 4 capture registers need to be read during the pointed read window. After that, the profile calculation is done:

$$\text{Profile 1} = \text{CC41C1V}_{\text{info}} - \text{CC41C0V}_{\text{info}}$$

$$\text{Profile 2} = \text{CC41C2V}_{\text{info}} - \text{CC41C1V}_{\text{info}}$$

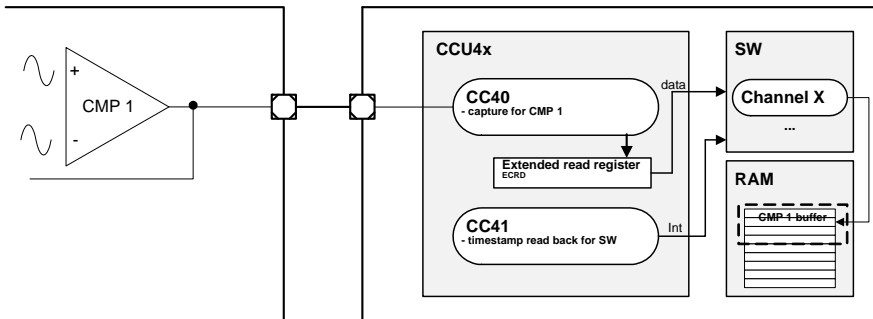
**Capture/Compare Unit 4 (CCU4)**

Profile 3= CC41C3V<sub>info</sub> - CC41C2V<sub>info</sub>

*Note: This is an example and therefore several Timer Slice configurations and software loops can be implemented.*

**High Dynamics Capturing**

In some cases the dynamics of the capture trigger(s) may vary greatly over time. This will impose that the software needs to be prepared for the worst case scenario, where the frequency of the capture triggers may be very high. In applications where cycle-by-cycle calculation is needed (calculation in each capture trigger), then this constraints needs to be met by the software. Nevertheless for applications where a cycle-by-cycle calculation is not needed, the software can read back the FIFO data register in a periodic base and fetch all the data that has been captured so far, **Figure 19-68**.



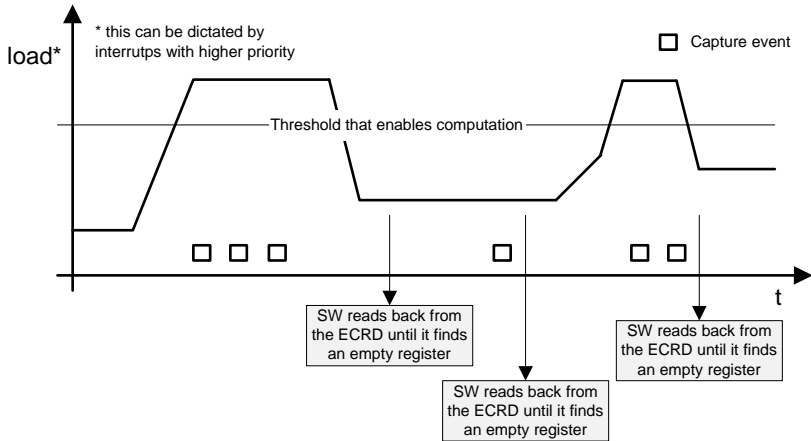
**Figure 19-68 High dynamics capturing with software controlled timestamp**

In this scenario, the software/CPU will read back the complete set of capture registers (2 or 4 depending on the chosen configuration), every time that an interrupt is triggered from the timestamp timer (the periodicity of this timer can also be adjusted on-the-fly).

Due to the fact that every capture register offers a full flag status bit, the software/CPU can always read back the complete set of registers. At the time of the data processing, this full flag is then checked, indicating if this value needs to be processed or not.

This FIFO read back functionality can also be used for applications that impose a heavy load on the system, which may not guarantee fixed access times to read back the captured data.

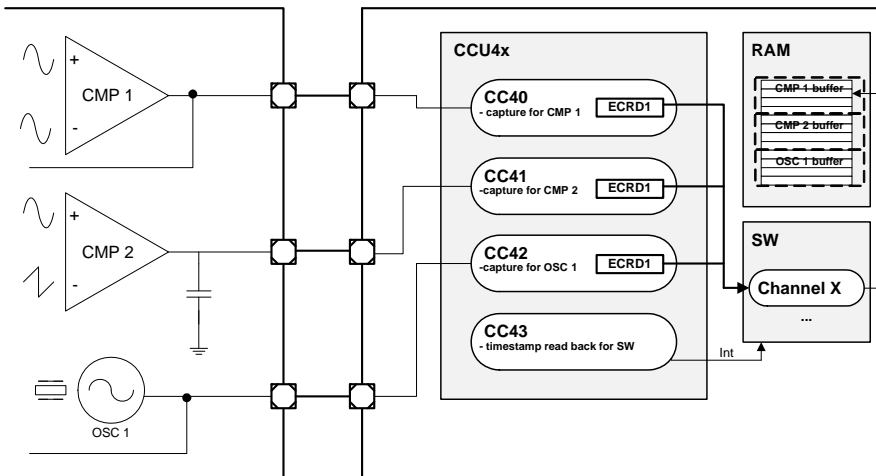
**Capture/Compare Unit 4 (CCU4)**



**Figure 19-69 Extended read back during high load**

**Capture Grouping**

In applications where multiple capture Timers are needed and the priority of the capture routines, does not imply that a cycle-by-cycle calculation needs to be done for every event, it may be suitable to group all the timers in the same CCU4x unit, [Figure 19-70](#).



**Figure 19-70 Capture grouping with extended read back**

---

### **Capture/Compare Unit 4 (CCU4)**

By setting the ECM bitfield for the Timer Slices used for capturing, the extended read back mode enables the reading back of data always in the proper capture order (from oldest to newest data). A timestamp timer is then used to trigger the Software/CPU to read back all the capture data present in the Timer Slices.

Every time that the interrupt is sensed, the Software/CPU (in this example) reads back the complete set of capture registers (via the ECRD address) for all Timer Slices. Due to the fact that each data read has a full flag indicator, the Software/CPU can read back the complete set of capture registers from all timers. This allows a fixed memory allocation that is as big as the number of captured registers, **Figure 19-71** (in this example 4 capture registers for each Timer Slice are being used).

The additional lost value bitfield (LCV) on the header of each ECRD data, will indicate if any capture trigger was lost between read operations (this can happen if the capture triggers are faster than the routine that is reading back the values).



**Capture/Compare Unit 4 (CCU4)**

<b>MEMORY</b>	<b>1<sup>st</sup> Read Back</b>			<b>2<sup>nd</sup> Read Back</b>			<b>2<sup>nd</sup> Read Back</b>		
	Timer 2 previous data	Previous		Timer 2 previous data	Previous		Timer 2 previous data	Previous	
	Timer 2 previous data	Previous		Timer 2 previous data	Previous		Timer 2 previous data	Previous	
	Timer 2 previous data	Previous		Timer 2 previous data	Previous		Timer 2 previous data	Previous	
	Timer 2 previous data	Previous		Timer 2 previous data	Previous		Timer 2 previous data	Previous	
	Timer 1 previous data	Previous		Timer 1 previous data	Previous		Timer 1 previous data	Previous	
	Timer 1 previous data	Previous		Timer 1 previous data	Previous		Timer 1 previous data	Previous	
	Timer 1 previous data	Previous		Timer 1 previous data	Previous		Timer 1 previous data	Previous	
	Timer 1 previous data	Previous		Timer 1 previous data	Previous		Timer 1 previous data	Previous	
	Timer 0 previous data	Previous		Timer 0 previous data	Previous		Timer 0 previous data	Previous	
	Timer 0 previous data	Previous		Timer 0 previous data	Empty		<b>Timer 0</b>	<b>xxxx<sub>H</sub></b>	Empty
	Timer 0 previous data	Previous		<b>Timer 0</b>	<b>5888<sub>H</sub></b>	Full	<b>Timer 0</b>	<b>5888<sub>H</sub></b>	Full
	<b>Timer 0</b>	<b>5790<sub>H</sub></b>	Full	<b>Timer 0</b>	<b>5790<sub>H</sub></b>	Full	<b>Timer 0</b>	<b>5790<sub>H</sub></b>	Full
...									
<b>10<sup>th</sup> Read Back</b>			<b>11<sup>th</sup> Read Back</b>			<b>12<sup>th</sup> Read Back</b>			
Timer 2 previous data	Previous		Timer 2 previous data	Previous		<b>Timer 2</b>	<b>xxxx<sub>H</sub></b>	Empty	
Timer 2 previous data	Previous		<b>Timer 2</b>	<b>xxxx<sub>H</sub></b>	Empty	<b>Timer 2</b>	<b>xxxx<sub>H</sub></b>	Empty	
<b>Timer 2</b>	<b>xxxx<sub>H</sub></b>	Empty	<b>Timer 2</b>	<b>xxxx<sub>H</sub></b>	Empty	<b>Timer 2</b>	<b>xxxx<sub>H</sub></b>	Empty	
<b>Timer 2</b>	<b>0009<sub>H</sub></b>	Full	<b>Timer 2</b>	<b>0009<sub>H</sub></b>	Full	<b>Timer 2</b>	<b>0009<sub>H</sub></b>	Full	
<b>Timer 1</b>	<b>0FCC<sub>H</sub></b>	Full	<b>Timer 1</b>	<b>0FCC<sub>H</sub></b>	Full	<b>Timer 1</b>	<b>0FCC<sub>H</sub></b>	Full	
<b>Timer 1</b>	<b>0FC0<sub>H</sub></b>	Full	<b>Timer 1</b>	<b>0FC0<sub>H</sub></b>	Full	<b>Timer 1</b>	<b>0FC0<sub>H</sub></b>	Full	
<b>Timer 1</b>	<b>0F09<sub>H</sub></b>	Full	<b>Timer 1</b>	<b>0F09<sub>H</sub></b>	Full	<b>Timer 1</b>	<b>0F09<sub>H</sub></b>	Full	
<b>Timer 1</b>	<b>0EFF<sub>H</sub></b>	Full	<b>Timer 1</b>	<b>0EFF<sub>H</sub></b>	Full	<b>Timer 1</b>	<b>0EFF<sub>H</sub></b>	Full	
<b>Timer 0</b>	<b>xxxx<sub>H</sub></b>	Empty	<b>Timer 0</b>	<b>xxxx<sub>H</sub></b>	Empty	<b>Timer 0</b>	<b>xxxx<sub>H</sub></b>	Empty	
<b>Timer 0</b>	<b>xxxx<sub>H</sub></b>	Empty	<b>Timer 0</b>	<b>xxxx<sub>H</sub></b>	Empty	<b>Timer 0</b>	<b>xxxx<sub>H</sub></b>	Empty	
<b>Timer 0</b>	<b>5888<sub>H</sub></b>	Full	<b>Timer 0</b>	<b>5888<sub>H</sub></b>	Full	<b>Timer 0</b>	<b>5888<sub>H</sub></b>	Full	
<b>Timer 0</b>	<b>5790<sub>H</sub></b>	Full	<b>Timer 0</b>	<b>5790<sub>H</sub></b>	Full	<b>Timer 0</b>	<b>5790<sub>H</sub></b>	Full	

**Figure 19-71 Memory structure for extended read back**

### 19.3 Service Request Generation

Each CCU4 slice has an interrupt structure as the one in [Figure 19-72](#). The register **CC4yINTS** is the status register for the interrupt sources. Each dedicated interrupt

**Capture/Compare Unit 4 (CCU4)**

source can be set or cleared by SW, by writing into the specific bit in the **CC4ySWS** and **CC4ySWR** registers respectively.

Each interrupt source can be enabled/disabled via the **CC4yINTE** register. An enabled interrupt source will always generate a pulse on the service request line even if the specific status bit was not cleared. **Table 19-9** describes the interrupt sources of each CCU4 slice.

The interrupt sources, Period Match while counting up and one Match while counting down are ORed together. The same mechanism is applied to the Compare Match while counting up and Compare Match while counting down.

The interrupt sources for the external events are directly linked with the configuration set on the **CC4yINS.EVxEM**. If an event is programmed to be active on both edges, that means that service request pulse is going to be generated when any transition on the external signal is detected. If the event is linked with a level function, the **CC4yINS.EVxEM** still can be programmed to enable a service request pulse. The TRAP event doesn't need any of extra configuration for generating the service request pulse when the slice enters the TRAP state.

**Table 19-9 Interrupt sources**

<b>Signal</b>	<b>Description</b>
CCINEV0_E	Event 0 edge(s) information from event selector. Used when an external signal should trigger an interrupt.
CCINEV1_E	Event 1 edge(s) information from event selector. Used when an external signal should trigger an interrupt.
CCINEV2_E	Event 2 edge(s) information from event selector. Used when an external signal should trigger an interrupt.
CCPM_U	Period Match while counting up
CCCM_U	Compare Match while counting up
CCCM_D	Compare Match while counting down
CCOM_D	One Match while counting down
Trap state set	Entering Trap State. Will set the E2AS

Capture/Compare Unit 4 (CCU4)

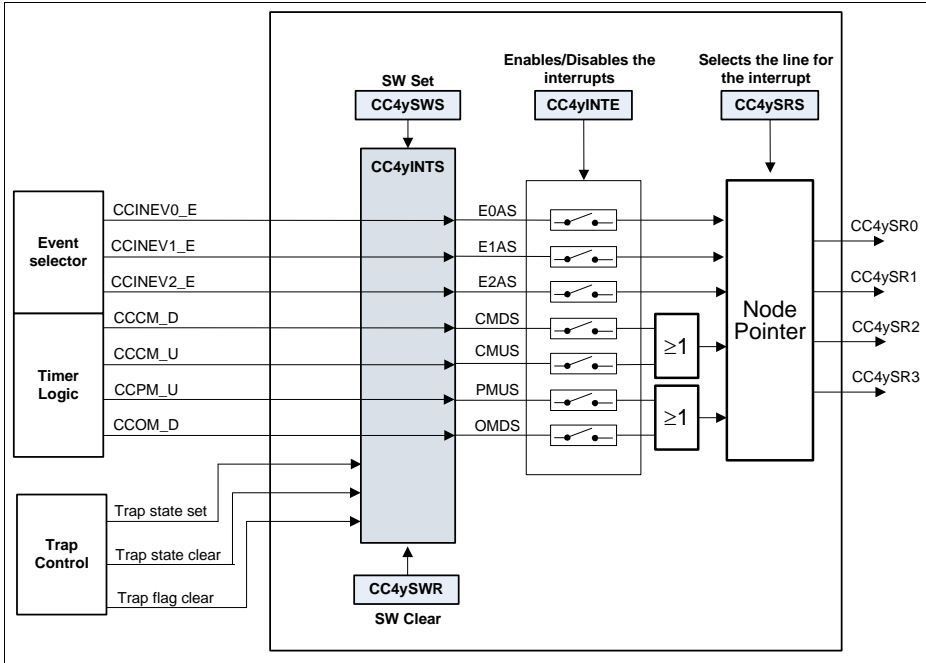
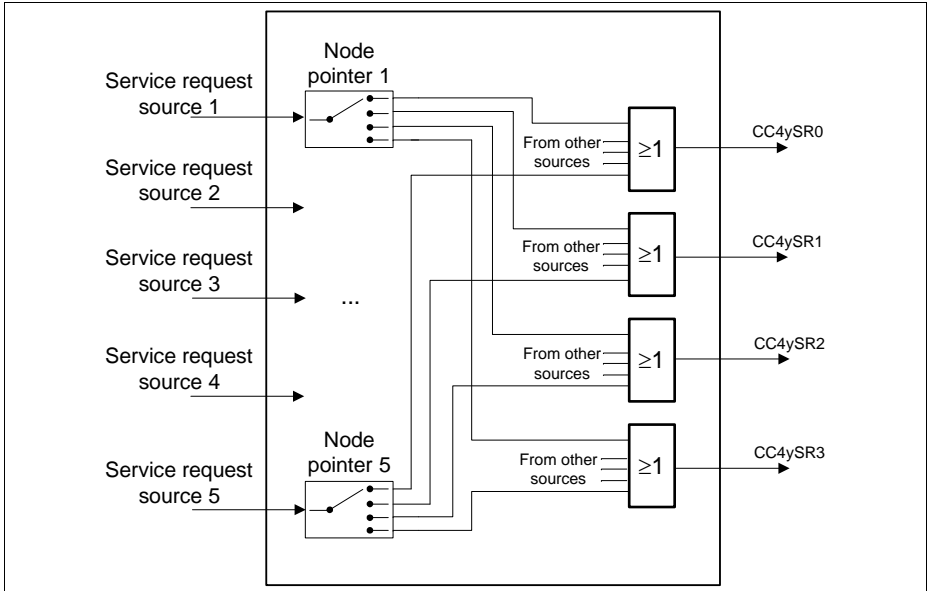


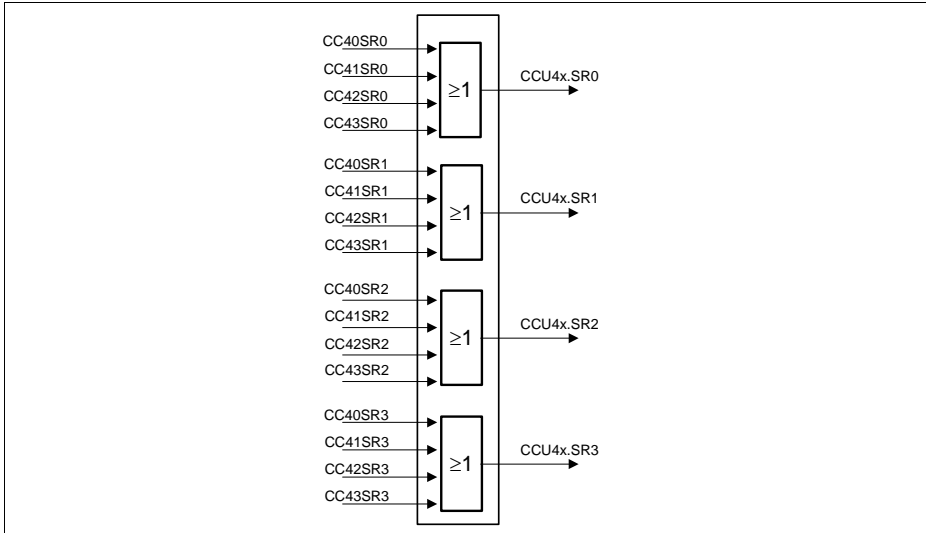
Figure 19-72 Slice interrupt structure overview

Each of the interrupt events can then be forwarded to one of the slice's four service request lines, [Figure 19-73](#). The value set on the **CC4ySRS** controls which interrupt event is mapped into which service request line.



**Figure 19-73 Slice Interrupt Node Pointer overview**

The four service request lines of each slice are OR together inside the kernel of the CCU4, see [Figure 19-74](#). This means that there are only four service request lines per CCU4, that can have in each line interrupt requests coming from different slices.



**Figure 19-74 CCU4 service request overview**

## 19.4 Debug Behavior

In suspend mode, the functional clocks for all slices as well the prescaler are stopped. The registers can still be accessed by the CPU (read only). This mode is useful for debugging purposes, e.g. where the current device status should be frozen in order to get a snapshot of the internal values. In suspend mode, all the slice timers are stopped. The suspend mode is non-intrusive concerning the register bits. This means register bits are not modified by hardware when entering or leaving the suspend mode.

Entry into suspend mode can be configured at the kernel level by means of the field **GCTRL.SUSCFG**.

The module is only functional after the suspend signal becomes inactive.

## 19.5 Power, Reset and Clock

The following sections describe the operating conditions, characteristics and timing requirements for the CCU4. All the timing information is related to the module clock,  $f_{CCU4}$ .

### 19.5.1 Clocks

#### Module Clock

The module clock of the CCU4 module is described in the SCU chapter as  $f_{PCLK}$ .

The bus interface clock of the CCU4 module is described in the SCU chapter as  $f_{MCLK}$ .

## Capture/Compare Unit 4 (CCU4)

It is possible to disable the module clock for the CCU4 via the **GSTAT** register, nevertheless, there may be a dependency of the  $f_{ccu4}$  through the different CCU4 instances. One should address the SCU Chapter for a complete description of the product clock scheme.

If module clock dependencies exist through different IP instances, then one can disable the module clock internally inside the specific CCU4, by disabling the prescaler (**GSTAT.PRB** = 0<sub>B</sub>).

### External Clock

It is possible to use an external clock as source for the prescaler, and consequently for all the timer Slices, CC4y. This external source can be connected to one of the CCU4x.CLK[C...A] inputs.

This external source is nevertheless synchronized against  $f_{ccu4}$ .

**Table 19-10 External clock operating conditions**

Parameter	Symbol	Values			Unit	Note / Test Condition
		Min.	Typ.	Max.		
Frequency	$f_{eclk}$	–	–	$f_{ccu4}/4$	MHz	
ON time	$t_{on_{eclk}}$	$2T_{ccu4}^{1)2)}$	–	–	ns	
OFF time	$t_{off_{eclk}}$	$2T_{ccu4}^{1)2)}$	–	–	ns	Only the rising edge is used

1) Only valid if the signal was not previously synchronized/generated with the fccu4 clock (or a synchronous clock)

2) 50% duty cycle is not obligatory

### 19.5.2 Power

The CCU4 is inside the power core domain, therefore no special considerations about power up or power down sequences need to be taken. For an explanation about the different power domains, please address the SCU (System Control Unit) chapter.

An internal power down mode for the CCU4, can be achieved by disabling the clock inside the CCU4 itself. For this one should set the **GSTAT** register with the default reset value (via the idle mode set register, **GIDLS**).

## 19.6 Initialization and System Dependencies

### 19.6.1 Initialization Sequence

The initialization sequence for an application that is using the CCU4, should be the following:

- 1<sup>st</sup> Step:** Enable the CCU4 clock via the specific SCU register, CGATCLR0.
- 2<sup>nd</sup> Step:** Enable the prescaler block, by writing 1<sub>B</sub> to the **GIDLC**.SPRB field.
- 3<sup>rd</sup> Step:** Configure the global CCU4 register **GCTRL**
- 4<sup>th</sup> Step:** Configure all the registers related to the required Timer Slice(s) functions, including the interrupt/service request configuration.
- 5<sup>th</sup> Step:** If needed, configure the startup value for a specific Compare Channel Status, of a Timer Slice, by writing 1<sub>B</sub> to the specific **GCSS**.SyTS.
- 6<sup>th</sup> Step:** Enable the specific timer slice(s), CC4y, by writing 1<sub>B</sub> to the specific **GIDLC**.CSyL.
- 7<sup>th</sup> Step:** For all the Timer Slices that should be started synchronously via SW, the specific system register localized in the SCU, CCUCON, that enables a synchronous timer start should be addressed. The SCU.GLCSTxx input signal needs to be configured previously as a start function, see [Section 19.2.7.1](#).

### 19.6.2 System Dependencies

Each CCU4 may have different dependencies regarding module and bus clock frequencies. This dependencies should be addressed in the SCU and System Architecture Chapters.

Dependencies between several peripherals, regarding different clock operating frequencies may also exist. This should be addressed before configuring the connectivity between the CCU4 and some other peripheral.

The following topics must be taken into consideration for good CCU4 and system operation:

- CCU4 module clock must be at maximum two times faster than the module bus interface clock
- Module input triggers for the CCU4 must not exceed the module clock frequency (if the triggers are generated internally in the device)
- Module input triggers for the CCU4 must not exceed the frequency dictated in [Section 19.5.1](#)
- Frequency of the CCU4 outputs used as triggers/functions on other modules, must be crosschecked on the end point
- Applying and removing CCU4 from reset, can cause unwanted operations in other modules. This can occur if the modules are using CCU4 outputs as triggers/functions.

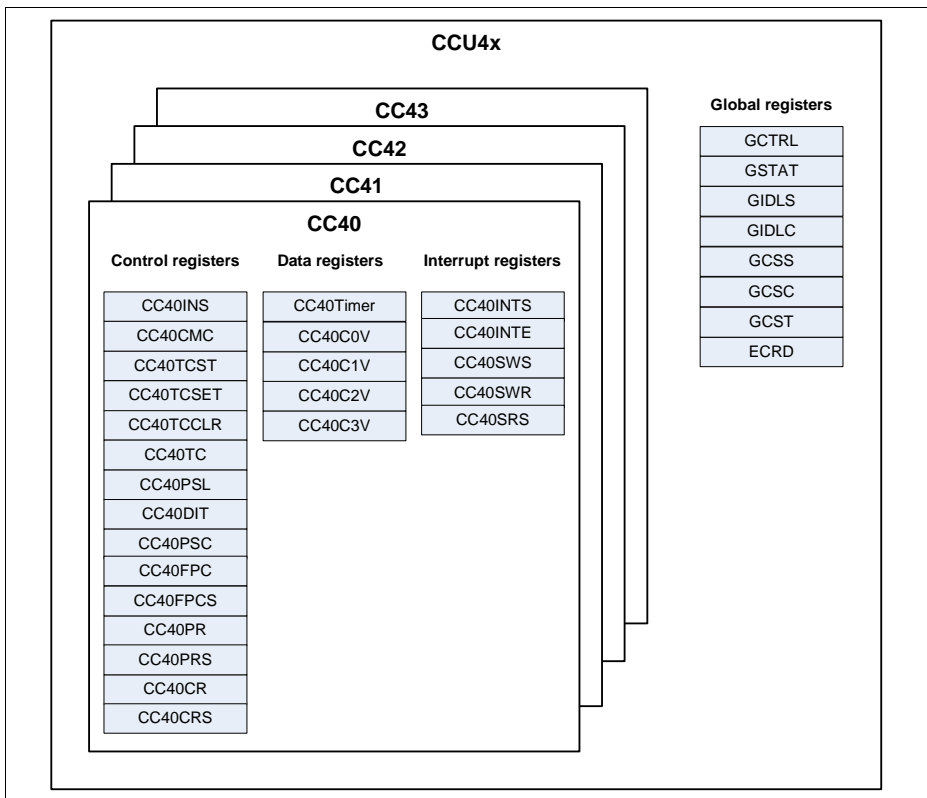
## 19.7 Registers

### Registers Overview

The absolute register address is calculated by adding:  
Module Base Address + Offset Address

**Table 19-11 Registers Address Space**

Module	Base Address	End Address	Note
CCU40	48040000 <sub>H</sub>	4804FFFF <sub>H</sub>	



**Figure 19-75 CCU4 registers overview**



**Table 19-12 Register Overview of CCU4**

Short Name	Description	Offset Addr. <sup>1)</sup>	Access Mode		Description See
			Read	Write	

**CCU4 Global Registers**

GCTRL	Module General Control Register	0000 <sub>H</sub>	U, PV	U, PV	<a href="#">Page 19-86</a>
GSTAT	General Slice Status Register	0004 <sub>H</sub>	U, PV	BE	<a href="#">Page 19-89</a>
GIDLS	General Idle Enable Register	0008 <sub>H</sub>	U, PV	U, PV	<a href="#">Page 19-90</a>
GIDLC	General Idle Disable Register	000C <sub>H</sub>	U, PV	U, PV	<a href="#">Page 19-92</a>
GCSS	General Channel Set Register	0010 <sub>H</sub>	U, PV	U, PV	<a href="#">Page 19-93</a>
GCSC	General Channel Clear Register	0014 <sub>H</sub>	U, PV	U, PV	<a href="#">Page 19-95</a>
GCST	General Channel Status Register	0018 <sub>H</sub>	U, PV	BE	<a href="#">Page 19-98</a>
MIDR	Module Identification Register	0080 <sub>H</sub>	U, PV	BE	<a href="#">Page 19-101</a>

**CC40 Registers**

CC40INS	Input Selector Unit Configuration	0100 <sub>H</sub>	U, PV	U, PV	<a href="#">Page 19-101</a>
CC40CMC	Connection Matrix Configuration	0104 <sub>H</sub>	U, PV	U, PV	<a href="#">Page 19-103</a>
CC40TST	Timer Run Status	0108 <sub>H</sub>	U, PV	BE	<a href="#">Page 19-106</a>
CC40TCSET	Timer Run Set	010C <sub>H</sub>	U, PV	U,PV	<a href="#">Page 19-107</a>
CC40TCCLR	Timer Run Clear	0110 <sub>H</sub>	U, PV	U, PV	<a href="#">Page 19-108</a>
CC40TC	General Timer Configuration	0114 <sub>H</sub>	U, PV	U, PV	<a href="#">Page 19-109</a>
CC40PSL	Output Passive Level Configuration	0118 <sub>H</sub>	U, PV	U, PV	<a href="#">Page 19-114</a>
CC40DIT	Dither Configuration	011C <sub>H</sub>	U, PV	BE	<a href="#">Page 19-114</a>
CC40DITS	Dither Shadow Register	0120 <sub>H</sub>	U, PV	U, PV	<a href="#">Page 19-115</a>
CC40PSC	Prescaler Configuration	0124 <sub>H</sub>	U, PV	U, PV	<a href="#">Page 19-116</a>
CC40FPC	Prescaler Compare Value	0128 <sub>H</sub>	U, PV	U, PV	<a href="#">Page 19-117</a>

**Capture/Compare Unit 4 (CCU4)**

**Table 19-12 Register Overview of CCU4 (cont'd)**

Short Name	Description	Offset Addr. <sup>1)</sup>	Access Mode		Description See
			Read	Write	
CC40FPCS	Prescaler Shadow Compare Value	012C <sub>H</sub>	U, PV	U, PV	<a href="#">Page 19-118</a>
CC40PR	Timer Period Value	0130 <sub>H</sub>	U, PV	BE	<a href="#">Page 19-118</a>
CC40PRS	Timer Period Shadow Value	0134 <sub>H</sub>	U, PV	U, PV	<a href="#">Page 19-119</a>
CC40CR	Timer Compare Value	0138 <sub>H</sub>	U, PV	BE	<a href="#">Page 19-120</a>
CC40CRS	Timer Compare Shadow Value	013C <sub>H</sub>	U, PV	U, PV	<a href="#">Page 19-121</a>
CC40TIMER	Timer Current Value	0170 <sub>H</sub>	U, PV	U, PV	<a href="#">Page 19-122</a>
CC40C0V	Capture Register 0 Value	0174 <sub>H</sub>	U, PV	BE	<a href="#">Page 19-122</a>
CC40C1V	Capture Register 1 Value	0178 <sub>H</sub>	U, PV	BE	<a href="#">Page 19-123</a>
CC40C2V	Capture Register 2 Value	017C <sub>H</sub>	U, PV	BE	<a href="#">Page 19-124</a>
CC40C3V	Capture Register 3 Value	0180 <sub>H</sub>	U, PV	BE	<a href="#">Page 19-125</a>
CC40INTS	Interrupt Status	01A0 <sub>H</sub>	U, PV	BE	<a href="#">Page 19-126</a>
CC40INTE	Interrupt Enable	01A4 <sub>H</sub>	U, PV	U, PV	<a href="#">Page 19-128</a>
CC40SRS	Interrupt Configuration	01A8 <sub>H</sub>	U, PV	U, PV	<a href="#">Page 19-130</a>
CC40SWS	Interrupt Status Set	01AC <sub>H</sub>	U, PV	U, PV	<a href="#">Page 19-131</a>
CC40SWR	Interrupt Status Clear	01B0 <sub>H</sub>	U, PV	U, PV	<a href="#">Page 19-133</a>
CC40ECD0	Extended Read Back 0	01B8 <sub>H</sub>	U, PV	BE	<a href="#">Page 19-134</a>
CC40ECD1	Extended Read Back 1	01BC <sub>H</sub>	U, PV	BE	<a href="#">Page 19-136</a>

**CC41 Registers**

CC41INS	Input Selector Unit Configuration	0200 <sub>H</sub>	U, PV	U, PV	<a href="#">Page 19-101</a>
CC41CMC	Connection Matrix Configuration	0204 <sub>H</sub>	U, PV	U, PV	<a href="#">Page 19-103</a>
CC41TST	Timer Run Status	0208 <sub>H</sub>	U, PV	BE	<a href="#">Page 19-106</a>
CC41TCSET	Timer Run Set	020C <sub>H</sub>	U, PV	U, PV	<a href="#">Page 19-107</a>
CC41TCCLR	Timer Run Clear	0210 <sub>H</sub>	U, PV	U, PV	<a href="#">Page 19-108</a>
CC41TC	General Timer Configuration	0214 <sub>H</sub>	U, PV	U, PV	<a href="#">Page 19-109</a>
CC41PSL	Output Passive Level Configuration	0218 <sub>H</sub>	U, PV	U, PV	<a href="#">Page 19-114</a>

**Capture/Compare Unit 4 (CCU4)**

**Table 19-12 Register Overview of CCU4 (cont'd)**

Short Name	Description	Offset Addr. <sup>1)</sup>	Access Mode		Description See
			Read	Write	
CC41DIT	Dither Configuration	021C <sub>H</sub>	U, PV	BE	<a href="#">Page 19-114</a>
CC41DITS	Dither Shadow Register	0220 <sub>H</sub>	U, PV	U, PV	<a href="#">Page 19-115</a>
CC41PSC	Prescaler Configuration	0224 <sub>H</sub>	U, PV	U, PV	<a href="#">Page 19-116</a>
CC41FPC	Prescaler Compare Value	0228 <sub>H</sub>	U, PV	U, PV	<a href="#">Page 19-117</a>
CC41FPCS	Prescaler Shadow Compare Value	022C <sub>H</sub>	U, PV	U, PV	<a href="#">Page 19-118</a>
CC41PR	Timer Period Value	0230 <sub>H</sub>	U, PV	BE	<a href="#">Page 19-118</a>
CC41PRS	Timer Period Shadow Value	0234 <sub>H</sub>	U, PV	U, PV	<a href="#">Page 19-119</a>
CC41CR	Timer Compare Value	0238 <sub>H</sub>	U, PV	BE	<a href="#">Page 19-120</a>
CC41CRS	Timer Compare Shadow Value	023C <sub>H</sub>	U, PV	U, PV	<a href="#">Page 19-121</a>
CC41TIMER	Timer Current Value	0270 <sub>H</sub>	U, PV	U, PV	<a href="#">Page 19-122</a>
CC41C0V	Capture Register 0 Value	0274 <sub>H</sub>	U, PV	BE	<a href="#">Page 19-122</a>
CC41C1V	Capture Register 1 Value	0278 <sub>H</sub>	U, PV	BE	<a href="#">Page 19-123</a>
CC41C2V	Capture Register 2 Value	027C <sub>H</sub>	U, PV	BE	<a href="#">Page 19-124</a>
CC41C3V	Capture Register 3 Value	0280 <sub>H</sub>	U, PV	BE	<a href="#">Page 19-125</a>
CC41INTS	Interrupt Status	02A0 <sub>H</sub>	U, PV	BE	<a href="#">Page 19-126</a>
CC41INTE	Interrupt Enable	02A4 <sub>H</sub>	U, PV	U, PV	<a href="#">Page 19-128</a>
CC41SRS	Interrupt Configuration	02A8 <sub>H</sub>	U, PV	U, PV	<a href="#">Page 19-130</a>
CC41SWS	Interrupt Status Set	02AC <sub>H</sub>	U, PV	U, PV	<a href="#">Page 19-131</a>
CC41SWR	Interrupt Status Clear	02B0 <sub>H</sub>	U, PV	U, PV	<a href="#">Page 19-133</a>
CC41ECD0	Extended Read Back 0	02B8 <sub>H</sub>	U, PV	BE	<a href="#">Page 19-134</a>
CC41ECD1	Extended Read Back 1	02BC <sub>H</sub>	U, PV	BE	<a href="#">Page 19-136</a>

**CC42 Registers**

CC42INS	Input Selector Unit Configuration	0300 <sub>H</sub>	U, PV	U, PV	<a href="#">Page 19-101</a>
CC42CMC	Connection Matrix Configuration	0304 <sub>H</sub>	U, PV	U, PV	<a href="#">Page 19-103</a>
CC42TST	Timer Run Status	0308 <sub>H</sub>	U, PV	BE	<a href="#">Page 19-106</a>
CC42TCSET	Timer Run Set	030C <sub>H</sub>	U, PV	U, PV	<a href="#">Page 19-107</a>

**Capture/Compare Unit 4 (CCU4)**

**Table 19-12 Register Overview of CCU4 (cont'd)**

Short Name	Description	Offset Addr. <sup>1)</sup>	Access Mode		Description See
			Read	Write	
CC42TCCLR	Timer Run Clear	0310 <sub>H</sub>	U, PV	U, PV	<a href="#">Page 19-108</a>
CC42TC	General Timer Configuration	0314 <sub>H</sub>	U, PV	U, PV	<a href="#">Page 19-109</a>
CC42PSL	Output Passive Level Configuration	0318 <sub>H</sub>	U, PV	U, PV	<a href="#">Page 19-114</a>
CC42DIT	Dither Configuration	031C <sub>H</sub>	U, PV	BE	<a href="#">Page 19-114</a>
CC42DITS	Dither Shadow Register	0320 <sub>H</sub>	U, PV	U, PV	<a href="#">Page 19-115</a>
CC42PSC	Prescaler Configuration	0324 <sub>H</sub>	U, PV	U, PV	<a href="#">Page 19-116</a>
CC42FPC	Prescaler Compare Value	0328 <sub>H</sub>	U, PV	U, PV	<a href="#">Page 19-117</a>
CC42FPCS	Prescaler Shadow Compare Value	032C <sub>H</sub>	U, PV	U, PV	<a href="#">Page 19-118</a>
CC42PR	Timer Period Value	0330 <sub>H</sub>	U, PV	BE	<a href="#">Page 19-118</a>
CC42PRS	Timer Period Shadow Value	0334 <sub>H</sub>	U, PV	U, PV	<a href="#">Page 19-119</a>
CC42CR	Timer Compare Value	0338 <sub>H</sub>	U, PV	BE	<a href="#">Page 19-120</a>
CC42CRS	Timer Compare Shadow Value	033C <sub>H</sub>	U, PV	U, PV	<a href="#">Page 19-121</a>
CC42TIMER	Timer Current Value	0370 <sub>H</sub>	U, PV	U, PV	<a href="#">Page 19-122</a>
CC42C0V	Capture Register 0 Value	0374 <sub>H</sub>	U, PV	BE	<a href="#">Page 19-122</a>
CC42C1V	Capture Register 1 Value	0378 <sub>H</sub>	U, PV	BE	<a href="#">Page 19-123</a>
CC42C2V	Capture Register 2 Value	037C <sub>H</sub>	U, PV	BE	<a href="#">Page 19-124</a>
CC42C3V	Capture Register 3 Value	0380 <sub>H</sub>	U, PV	BE	<a href="#">Page 19-125</a>
CC42INTS	Interrupt Status	03A0 <sub>H</sub>	U, PV	BE	<a href="#">Page 19-126</a>
CC42INTE	Interrupt Enable	03A4 <sub>H</sub>	U, PV	U, PV	<a href="#">Page 19-128</a>
CC42SRS	Interrupt Configuration	03A8 <sub>H</sub>	U, PV	U, PV	<a href="#">Page 19-130</a>
CC42SWS	Interrupt Status Set	03AC <sub>H</sub>	U, PV	U, PV	<a href="#">Page 19-131</a>
CC42SWR	Interrupt Status Clear	03B0 <sub>H</sub>	U, PV	U, PV	<a href="#">Page 19-133</a>
CC42ECD0	Extended Read Back 0	03B8 <sub>H</sub>	U, PV	BE	<a href="#">Page 19-134</a>
CC42ECD1	Extended Read Back 1	03BC <sub>H</sub>	U, PV	BE	<a href="#">Page 19-136</a>

**CC43 Registers**

CC43INS	Input Selector Unit Configuration	0400 <sub>H</sub>	U, PV	U, PV	<a href="#">Page 19-101</a>
---------	-----------------------------------	-------------------	-------	-------	-----------------------------

**Capture/Compare Unit 4 (CCU4)**

**Table 19-12 Register Overview of CCU4 (cont'd)**

Short Name	Description	Offset Addr. <sup>1)</sup>	Access Mode		Description See
			Read	Write	
CC43CMC	Connection Matrix Configuration	0404 <sub>H</sub>	U, PV	U, PV	<a href="#">Page 19-103</a>
CC43TST	Timer Run Status	0408 <sub>H</sub>	U, PV	BE	<a href="#">Page 19-106</a>
CC43TCSET	Timer Run Set	040C <sub>H</sub>	U, PV	U,PV	<a href="#">Page 19-107</a>
CC43TCCLR	Timer Run Clear	0410 <sub>H</sub>	U, PV	U, PV	<a href="#">Page 19-108</a>
CC43TC	General Timer Configuration	0414 <sub>H</sub>	U, PV	U, PV	<a href="#">Page 19-109</a>
CC43PSL	Output Passive Level Configuration	0418 <sub>H</sub>	U, PV	U, PV	<a href="#">Page 19-114</a>
CC43DIT	Dither Configuration	041C <sub>H</sub>	U, PV	BE	<a href="#">Page 19-114</a>
CC43DITS	Dither Shadow Register	0420 <sub>H</sub>	U, PV	U, PV	<a href="#">Page 19-115</a>
CC43PSC	Prescaler Configuration	0424 <sub>H</sub>	U, PV	U, PV	<a href="#">Page 19-116</a>
CC43FPC	Prescaler Compare Value	0428 <sub>H</sub>	U, PV	U, PV	<a href="#">Page 19-117</a>
CC43FPCS	Prescaler Shadow Compare Value	042C <sub>H</sub>	U, PV	U, PV	<a href="#">Page 19-118</a>
CC43PR	Timer Period Value	0430 <sub>H</sub>	U, PV	BE	<a href="#">Page 19-118</a>
CC43PRS	Timer Period Shadow Value	0434 <sub>H</sub>	U, PV	U, PV	<a href="#">Page 19-119</a>
CC43CR	Timer Compare Value	0438 <sub>H</sub>	U, PV	BE	<a href="#">Page 19-120</a>
CC43CRS	Timer Compare Shadow Value	043C <sub>H</sub>	U, PV	U, PV	<a href="#">Page 19-121</a>
CC43TIMER	Timer Current Value	0470 <sub>H</sub>	U, PV	U, PV	<a href="#">Page 19-122</a>
CC43C0V	Capture Register 0 Value	0474 <sub>H</sub>	U, PV	BE	<a href="#">Page 19-122</a>
CC43C1V	Capture Register 1 Value	0478 <sub>H</sub>	U, PV	BE	<a href="#">Page 19-123</a>
CC43C2V	Capture Register 2 Value	047C <sub>H</sub>	U, PV	BE	<a href="#">Page 19-124</a>
CC43C3V	Capture Register 3 Value	0480 <sub>H</sub>	U, PV	BE	<a href="#">Page 19-125</a>
CC43INTS	Interrupt Status	04A0 <sub>H</sub>	U, PV	BE	<a href="#">Page 19-126</a>
CC43INTE	Interrupt Enable	04A4 <sub>H</sub>	U, PV	U, PV	<a href="#">Page 19-128</a>
CC43SRS	Interrupt Configuration	04A8 <sub>H</sub>	U, PV	U, PV	<a href="#">Page 19-130</a>
CC43SWS	Interrupt Status Set	04AC <sub>H</sub>	U, PV	U, PV	<a href="#">Page 19-131</a>
CC43SWR	Interrupt Status Clear	04B0 <sub>H</sub>	U, PV	U, PV	<a href="#">Page 19-133</a>

**Capture/Compare Unit 4 (CCU4)**

**Table 19-12 Register Overview of CCU4 (cont'd)**

Short Name	Description	Offset Addr. <sup>1)</sup>	Access Mode		Description See
			Read	Write	
CC43ECD0	Extended Read Back 0	04B8 <sub>H</sub>	U, PV	BE	<a href="#">Page 19-134</a>
CC43ECD1	Extended Read Back 1	04BC <sub>H</sub>	U, PV	BE	<a href="#">Page 19-136</a>

1) The absolute register address is calculated as follows:  
Module Base Address + Offset Address (shown in this column)

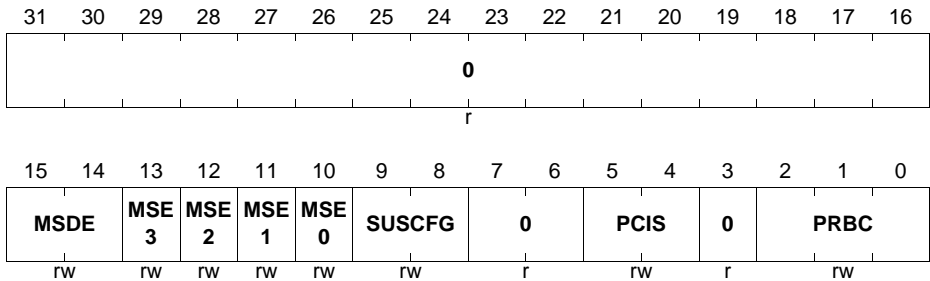
### 19.7.1 Global Registers

#### GCTRL

The register contains the global configuration fields that affect all the timer slices inside CCU4.

#### GCTRL

**Global Control Register (0000<sub>H</sub>) Reset Value: 00000000<sub>H</sub>**



**Capture/Compare Unit 4 (CCU4)**

<b>Field</b>	<b>Bits</b>	<b>Type</b>	<b>Description</b>
<b>PRBC</b>	[2:0]	rw	<p><b>Prescaler Clear Configuration</b></p> <p>This register controls how the prescaler Run Bit and internal registers are cleared.</p> <p>000<sub>B</sub> SW only</p> <p>001<sub>B</sub> <b>GSTAT</b>.PRB and prescaler registers are cleared when the Run Bit of CC40 is cleared.</p> <p>010<sub>B</sub> <b>GSTAT</b>.PRB and prescaler registers are cleared when the Run Bit of CC41 is cleared.</p> <p>011<sub>B</sub> <b>GSTAT</b>.PRB and prescaler registers are cleared when the Run Bit of CC42 is cleared.</p> <p>100<sub>B</sub> <b>GSTAT</b>.PRB and prescaler registers are cleared when the Run Bit of CC43 is cleared.</p>
<b>PCIS</b>	[5:4]	rw	<p><b>Prescaler Input Clock Selection</b></p> <p>00<sub>B</sub> Module clock</p> <p>01<sub>B</sub> CCU4x.ECLKA</p> <p>10<sub>B</sub> CCU4x.ECLKB</p> <p>11<sub>B</sub> CCU4x.ECLKC</p>
<b>SUSCFG</b>	[9:8]	rw	<p><b>Suspend Mode Configuration</b></p> <p>This field controls the entering in suspend mode for all the CAPCOM4 slices.</p> <p>00<sub>B</sub> Suspend request ignored. The module never enters in suspend</p> <p>01<sub>B</sub> Stops all the running slices immediately. Safe stop is not applied.</p> <p>10<sub>B</sub> Stops the block immediately and clamps all the outputs to PASSIVE state. Safe stop is applied.</p> <p>11<sub>B</sub> Waits for the roll over of each slice to stop and clamp the slices outputs. Safe stop is applied.</p>
<b>MSE0</b>	10	rw	<p><b>Slice 0 Multi Channel shadow transfer enable</b></p> <p>When this field is set, a shadow transfer of slice 0 can be requested not only by SW but also via the CCU4x.MCSS input.</p> <p>0<sub>B</sub> Shadow transfer can only be requested by SW</p> <p>1<sub>B</sub> Shadow transfer can be requested via SW and via the CCU4x.MCSS input.</p>

**Capture/Compare Unit 4 (CCU4)**

Field	Bits	Type	Description
<b>MSE1</b>	11	rw	<p><b>Slice 1 Multi Channel shadow transfer enable</b> When this field is set, a shadow transfer of slice 1 can be requested not only by SW but also via the CCU4x.MCSS input.</p> <p>0<sub>B</sub> Shadow transfer can only be requested by SW 1<sub>B</sub> Shadow transfer can be requested via SW and via the CCU4x.MCSS input.</p>
<b>MSE2</b>	12	rw	<p><b>Slice 2 Multi Channel shadow transfer enable</b> When this field is set, a shadow transfer of slice 2 can be requested not only by SW but also via the CCU4x.MCSS input.</p> <p>0<sub>B</sub> Shadow transfer can only be requested by SW 1<sub>B</sub> Shadow transfer can be requested via SW and via the CCU4x.MCSS input.</p>
<b>MSE3</b>	13	rw	<p><b>Slice 3 Multi Channel shadow transfer enable</b> When this field is set, a shadow transfer of slice 3 can be requested not only by SW but also via the CCU4x.MCSS input.</p> <p>0<sub>B</sub> Shadow transfer can only be requested by SW 1<sub>B</sub> Shadow transfer can be requested via SW and via the CCU4x.MCSS input.</p>
<b>MSDE</b>	[15:14]	rw	<p><b>Multi Channel shadow transfer request configuration</b> This field configures the type of shadow transfer requested via the CCU4x.MCSS input. The field <b>CC4yTC.MSEy</b> needs to be set in order for this configuration to have any effect.</p> <p>00<sub>B</sub> Only the shadow transfer for period and compare values is requested 01<sub>B</sub> Shadow transfer for the compare, period and prescaler compare values is requested 10<sub>B</sub> Reserved 11<sub>B</sub> Shadow transfer for the compare, period, prescaler and dither compare values is requested</p>



**Capture/Compare Unit 4 (CCU4)**

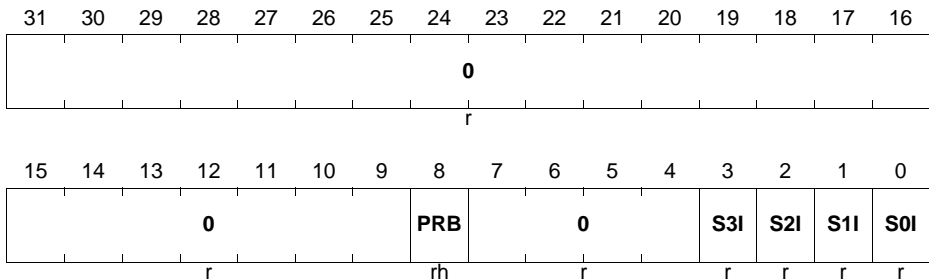
Field	Bits	Type	Description
0	3, [7:6], [31:16]	r	<b>Reserved</b> A read always returns 0.

**GSTAT**

The register contains the status of the prescaler and each timer slice (idle mode or running).

**GSTAT**

**Global Status Register (0004<sub>H</sub>)**      **Reset Value: 000000F<sub>H</sub>**



Field	Bits	Type	Description
<b>S0I</b>	0	r	<b>CC40 IDLE status</b> This bit indicates if the CC40 slice is in IDLE mode or not. In IDLE mode the clocks for the CC40 slice are stopped. 0 <sub>B</sub> Running 1 <sub>B</sub> Idle
<b>S1I</b>	1	r	<b>CC41 IDLE status</b> This bit indicates if the CC41 slice is in IDLE mode or not. In IDLE mode the clocks for the CC41 slice are stopped. 0 <sub>B</sub> Running 1 <sub>B</sub> Idle

**Capture/Compare Unit 4 (CCU4)**

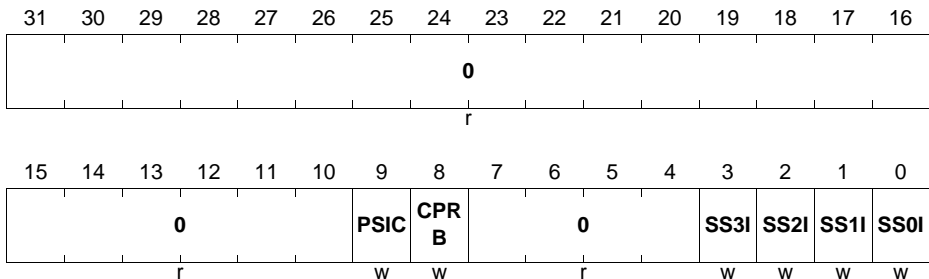
Field	Bits	Type	Description
<b>S2I</b>	2	r	<b>CC42 IDLE status</b> This bit indicates if the CC42 slice is in IDLE mode or not. In IDLE mode the clocks for the CC42 slice are stopped. 0 <sub>B</sub> Running 1 <sub>B</sub> Idle
<b>S3I</b>	3	r	<b>CC43 IDLE status</b> This bit indicates if the CC43 slice is in IDLE mode or not. In IDLE mode the clocks for the CC43 slice are stopped. 0 <sub>B</sub> Running 1 <sub>B</sub> Idle
<b>PRB</b>	8	rh	<b>Prescaler Run Bit</b> 0 <sub>B</sub> Prescaler is stopped 1 <sub>B</sub> Prescaler is running
<b>0</b>	[7:4], [31:9]	r	<b>Reserved</b> Read always returns 0.

**GIDLS**

Through this register one can set the prescaler and the specific timer slices into idle mode.

**GIDLS**

**Global Idle Set (0008<sub>H</sub>) Reset Value: 00000000<sub>H</sub>**



**Capture/Compare Unit 4 (CCU4)**

<b>Field</b>	<b>Bits</b>	<b>Type</b>	<b>Description</b>
<b>SS0I</b>	0	w	<b>CC40 IDLE mode set</b> Writing a 1 <sub>B</sub> to this bit sets the CC40 slice in IDLE mode. The clocks for the slice are stopped when in IDLE mode. When entering IDLE, the internal slice registers are not cleared. A read access always returns 0.
<b>SS1I</b>	1	w	<b>CC41 IDLE mode set</b> Writing a 1 <sub>B</sub> to this bit sets the CC41 slice in IDLE mode. The clocks for the slice are stopped when in IDLE mode. When entering IDLE, the internal slice registers are not cleared. A read access always returns 0.
<b>SS2I</b>	2	w	<b>CC42 IDLE mode set</b> Writing a 1 <sub>B</sub> to this bit sets the CC42 slice in IDLE mode. The clocks for the slice are stopped when in IDLE mode. When entering IDLE, the internal slice registers are not cleared. A read access always returns 0.
<b>SS3I</b>	3	w	<b>CC43 IDLE mode set</b> Writing a 1 <sub>B</sub> to this bit sets the CC43 slice in IDLE mode. The clocks for the slice are stopped when in IDLE mode. When entering IDLE, the internal slice registers are not cleared. A read access always returns 0.
<b>CPRB</b>	8	w	<b>Prescaler Run Bit Clear</b> Writing a 1 <sub>B</sub> into this register clears the Run Bit of the prescaler. Prescaler internal registers are not cleared. A read always returns 0.
<b>PSIC</b>	9	w	<b>Prescaler clear</b> Writing a 1 <sub>B</sub> to this register clears the prescaler counter. It also loads the PSIV into the PVAL field for all Timer Slices. This performs a re alignment of the timer clock for all Slices. The Run Bit of the prescaler is not cleared. A read always returns 0.
<b>0</b>	[7:4], [31:10]	r	<b>Reserved</b> Read always returns 0.

**Capture/Compare Unit 4 (CCU4)**

**GIDLC**

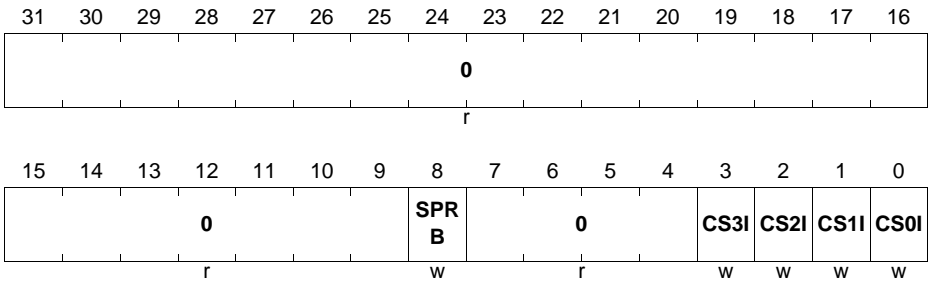
Through this register one can remove the prescaler and the specific timer slices from idle mode.

**GIDLC**

**Global Idle Clear**

**(000C<sub>H</sub>)**

**Reset Value: 00000000<sub>H</sub>**



Field	Bits	Type	Description
<b>CS0I</b>	0	w	<b>CC40 IDLE mode clear</b> Writing a 1 <sub>B</sub> to this bit removes the CC40 from IDLE mode. A read access always returns 0.
<b>CS1I</b>	1	w	<b>CC41 IDLE mode clear</b> Writing a 1 <sub>B</sub> to this bit removes the CC41 from IDLE mode. A read access always returns 0.
<b>CS2I</b>	2	w	<b>CC42 IDLE mode clear</b> Writing a 1 <sub>B</sub> to this bit removes the CC42 from IDLE mode. A read access always returns 0.
<b>CS3I</b>	3	w	<b>CC43 IDLE mode clear</b> Writing a 1 <sub>B</sub> to this bit removes the CC43 from IDLE mode. A read access always returns 0.
<b>SPRB</b>	8	w	<b>Prescaler Run Bit Set</b> Writing a 1 <sub>B</sub> into this register sets the Run Bit of the prescaler. A read always returns 0.
<b>0</b>	[7:4], [31:9]	r	<b>Reserved</b> Read always returns 0.

**GCSS**

Through this register one can request a shadow transfer for the specific timer slice(s) and set the status bit for each of the compare channels.

**Capture/Compare Unit 4 (CCU4)**

**GCSS**

**Global Channel Set**

**(0010<sub>H</sub>)**

**Reset Value: 00000000<sub>H</sub>**

31	30	29	28	27	26	25	24	23	22	21	20	19	18	17	16	
0												S3S TS	S2S TS	S1S TS	S0S TS	
												r	w	w	w	w
15	14	13	12	11	10	9	8	7	6	5	4	3	2	1	0	
0	S3P SE	S3D SE	S3S E	0	S2P SE	S2D SE	S2S E	0	S1P SE	S1D SE	S1S E	0	S0P SE	S0D SE	S0S E	
r	w	w	w	r	w	w	w	r	w	w	w	r	w	w	w	

Field	Bits	Type	Description
<b>S0SE</b>	0	w	<b>Slice 0 shadow transfer set enable</b> Writing a 1 <sub>B</sub> to this bit will set the <b>GCST.S0SS</b> field, enabling then a shadow transfer for the Period, Compare and Passive level values. A read always returns 0.
<b>S0DSE</b>	1	w	<b>Slice 0 Dither shadow transfer set enable</b> Writing a 1 <sub>B</sub> to this bit will set the <b>GCST.S0DSS</b> field, enabling then a shadow transfer for the Dither compare value. A read always returns 0.
<b>S0PSE</b>	2	w	<b>Slice 0 Prescaler shadow transfer set enable</b> Writing a 1 <sub>B</sub> to this bit will set the <b>GCST.S0PSS</b> field, enabling then a shadow transfer for the prescaler compare value. A read always returns 0.
<b>S1SE</b>	4	w	<b>Slice 1 shadow transfer set enable</b> Writing a 1 <sub>B</sub> to this bit will set the <b>GCST.S1SS</b> field, enabling then a shadow transfer for the Period, Compare and Passive level values. A read always returns 0.
<b>S1DSE</b>	5	w	<b>Slice 1 Dither shadow transfer set enable</b> Writing a 1 <sub>B</sub> to this bit will set the <b>GCST.S1DSS</b> field, enabling then a shadow transfer for the Dither compare value. A read always returns 0.

**Capture/Compare Unit 4 (CCU4)**

Field	Bits	Type	Description
<b>S1PSE</b>	6	w	<b>Slice 1 Prescaler shadow transfer set enable</b> Writing a 1 <sub>B</sub> to this bit will set the <b>GCST.S1PSS</b> field, enabling then a shadow transfer for the prescaler compare value. A read always returns 0.
<b>S2SE</b>	8	w	<b>Slice 2 shadow transfer set enable</b> Writing a 1 <sub>B</sub> to this bit will set the <b>GCST.S2SS</b> field, enabling then a shadow transfer for the Period, Compare and Passive level values. A read always returns 0.
<b>S2DSE</b>	9	w	<b>Slice 2 Dither shadow transfer set enable</b> Writing a 1 <sub>B</sub> to this bit will set the <b>GCST.S2DSS</b> field, enabling then a shadow transfer for the Dither compare value. A read always returns 0.
<b>S2PSE</b>	10	w	<b>Slice 2 Prescaler shadow transfer set enable</b> Writing a 1 <sub>B</sub> to this bit will set the <b>GCST.S2PSS</b> field, enabling then a shadow transfer for the prescaler compare value. A read always returns 0.
<b>S3SE</b>	12	w	<b>Slice 3 shadow transfer set enable</b> Writing a 1 <sub>B</sub> to this bit will set the <b>GCST.S3SS</b> field, enabling then a shadow transfer for the Period, Compare and Passive level values. A read always returns 0.
<b>S3DSE</b>	13	w	<b>Slice 3 Dither shadow transfer set enable</b> Writing a 1 <sub>B</sub> to this bit will set the <b>GCST.S3DSS</b> field, enabling then a shadow transfer for the Dither compare value. A read always returns 0.
<b>S3PSE</b>	14	w	<b>Slice 3 Prescaler shadow transfer set enable</b> Writing a 1 <sub>B</sub> to this bit will set the <b>GCST.S3PSS</b> field, enabling then a shadow transfer for the prescaler compare value. A read always returns 0.
<b>S0STS</b>	16	w	<b>Slice 0 status bit set</b> Writing a 1 <sub>B</sub> into this field sets the status bit of slice 0 ( <b>GCST.CC40ST</b> ) to 1 <sub>B</sub> . A read always returns 0.

**Capture/Compare Unit 4 (CCU4)**

Field	Bits	Type	Description
<b>S1STS</b>	17	w	<b>Slice 1 status bit set</b> Writing a 1 <sub>B</sub> into this field sets the status bit of slice 1 ( <b>GCST.CC41ST</b> ) to 1 <sub>B</sub> . A read always returns 0.
<b>S2STS</b>	18	w	<b>Slice 2 status bit set</b> Writing a 1 <sub>B</sub> into this field sets the status bit of slice 2 ( <b>GCST.CC42ST</b> ) to 1 <sub>B</sub> . A read always returns 0.
<b>S3STS</b>	19	w	<b>Slice 3 status bit set</b> Writing a 1 <sub>B</sub> into this field sets the status bit of slice 3 ( <b>GCST.CC43ST</b> ) to 1 <sub>B</sub> . A read always returns 0.
<b>0</b>	3, 7, 11, 15, [31:20]	r	<b>Reserved</b> Read always returns 0.

**GCSC**

Through this register one can reset a shadow transfer request for the specific timer slice and clear the status bit for each the compare channels.

**GCSC**

**Global Channel Clear**

**(0014<sub>H</sub>)**

**Reset Value: 00000000<sub>H</sub>**

31	30	29	28	27	26	25	24	23	22	21	20	19	18	17	16	
0												<b>S3S</b>	<b>S2S</b>	<b>S1S</b>	<b>S0S</b>	
												<b>TC</b>	<b>TC</b>	<b>TC</b>	<b>TC</b>	
												r	w	w	w	w
15	14	13	12	11	10	9	8	7	6	5	4	3	2	1	0	
<b>0</b>	<b>S3P</b>	<b>S3D</b>	<b>S3S</b>	<b>0</b>	<b>S2P</b>	<b>S2D</b>	<b>S2S</b>	<b>0</b>	<b>S1P</b>	<b>S1D</b>	<b>S1S</b>	<b>0</b>	<b>S0P</b>	<b>S0D</b>	<b>S0S</b>	
	<b>SC</b>	<b>SC</b>	<b>C</b>		<b>SC</b>	<b>SC</b>	<b>C</b>		<b>SC</b>	<b>SC</b>	<b>C</b>		<b>SC</b>	<b>SC</b>	<b>C</b>	
r	w	w	w	r	w	w	w	r	w	w	w	r	w	w	w	

**Capture/Compare Unit 4 (CCU4)**

<b>Field</b>	<b>Bits</b>	<b>Type</b>	<b>Description</b>
<b>S0SC</b>	0	w	<b>Slice 0 shadow transfer clear</b> Writing a 1 <sub>B</sub> to this bit will clear the <b>GCST.S0SS</b> field, canceling any pending shadow transfer for the Period, Compare and Passive level values. A read always returns 0.
<b>S0DSC</b>	1	w	<b>Slice 0 Dither shadow transfer clear</b> Writing a 1 <sub>B</sub> to this bit will clear the <b>GCST.S0DSS</b> field, canceling any pending shadow transfer for the Dither compare value. A read always returns 0.
<b>S0PSC</b>	2	w	<b>Slice 0 Prescaler shadow transfer clear</b> Writing a 1 <sub>B</sub> to this bit will clear the <b>GCST.S0PSS</b> field, canceling any pending shadow transfer for the prescaler compare value. A read always returns 0.
<b>S1SC</b>	4	w	<b>Slice 1 shadow transfer clear</b> Writing a 1 <sub>B</sub> to this bit will clear the <b>GCST.S1SS</b> field, canceling any pending shadow transfer for the Period, Compare and Passive level values. A read always returns 0.
<b>S1DSC</b>	5	w	<b>Slice 1 Dither shadow transfer clear</b> Writing a 1 <sub>B</sub> to this bit will clear the <b>GCST.S1DSS</b> field, canceling any pending shadow transfer for the Dither compare value. A read always returns 0.
<b>S1PSC</b>	6	w	<b>Slice 1 Prescaler shadow transfer clear</b> Writing a 1 <sub>B</sub> to this bit will clear the <b>GCST.S1PSS</b> field, canceling any pending shadow transfer for the prescaler compare value. A read always returns 0.
<b>S2SC</b>	8	w	<b>Slice 2 shadow transfer clear</b> Writing a 1 <sub>B</sub> to this bit will clear the <b>GCST.S2SS</b> field, canceling any pending shadow transfer for the Period, Compare and Passive level values. A read always returns 0.



**Capture/Compare Unit 4 (CCU4)**

Field	Bits	Type	Description
<b>S2DSC</b>	9	w	<b>Slice 2 Dither shadow transfer clear</b> Writing a 1 <sub>B</sub> to this bit will clear the <b>GCST.S2DSS</b> field, canceling any pending shadow transfer for the Dither compare value. A read always returns 0.
<b>S2PSC</b>	10	w	<b>Slice 2 Prescaler shadow transfer clear</b> Writing a 1 <sub>B</sub> to this bit will clear the <b>GCST.S2PSS</b> field, canceling any pending shadow transfer for the prescaler compare value. A read always returns 0.
<b>S3SC</b>	12	w	<b>Slice 3 shadow transfer clear</b> Writing a 1 <sub>B</sub> to this bit will clear the <b>GCST.S3SS</b> field, canceling any pending shadow transfer for the Period, Compare and Passive level values. A read always returns 0.
<b>S3DSC</b>	13	w	<b>Slice 3 Dither shadow transfer clear</b> Writing a 1 <sub>B</sub> to this bit will clear the <b>GCST.S3DSS</b> field, canceling any pending shadow transfer for the Dither compare value. A read always returns 0.
<b>S3PSC</b>	14	w	<b>Slice 3 Prescaler shadow transfer clear</b> Writing a 1 <sub>B</sub> to this bit will clear the <b>GCST.S3PSS</b> field, canceling any pending shadow transfer for the prescaler compare value. A read always returns 0.
<b>S0STC</b>	16	w	<b>Slice 0 status bit clear</b> Writing a 1 <sub>B</sub> into this field clears the status bit of slice 0 ( <b>GCST.CC40ST</b> ) to 0 <sub>B</sub> . A read always returns 0.
<b>S1STC</b>	17	w	<b>Slice 1 status bit clear</b> Writing a 1 <sub>B</sub> into this field clears the status bit of slice 1 ( <b>GCST.CC41ST</b> ) to 0 <sub>B</sub> . A read always returns 0.
<b>S2STC</b>	18	w	<b>Slice 2 status bit clear</b> Writing a 1 <sub>B</sub> into this field clears the status bit of slice 2 ( <b>GCST.CC42ST</b> ) to 0 <sub>B</sub> . A read always returns 0.

**Capture/Compare Unit 4 (CCU4)**

Field	Bits	Type	Description
<b>S3STC</b>	19	w	<b>Slice 3 status bit clear</b> Writing a 1 <sub>B</sub> into this field clears the status bit of slice 3 ( <b>GCST.CC43ST</b> ) to 0 <sub>B</sub> . A read always returns 0.
<b>0</b>	3, 7, 11, 15, [31:20]	r	<b>Reserved</b> Read always returns 0.

**GCST**

This register holds the information of the shadow transfer requests and of each timer slice status bit.

**GCST**

**Global Channel Status (0018<sub>H</sub>)** **Reset Value: 00000000<sub>H</sub>**

31	30	29	28	27	26	25	24	23	22	21	20	19	18	17	16	
0												<b>CC4 3ST</b>	<b>CC4 2ST</b>	<b>CC4 1ST</b>	<b>CC4 0ST</b>	
												r	rh	rh	rh	rh
15	14	13	12	11	10	9	8	7	6	5	4	3	2	1	0	
0	<b>S3P SS</b>	<b>S3D SS</b>	<b>S3S S</b>	0	<b>S2P SS</b>	<b>S2D SS</b>	<b>S2S S</b>	0	<b>S1P SS</b>	<b>S1D SS</b>	<b>S1S S</b>	0	<b>S0P SS</b>	<b>S0D SS</b>	<b>S0S S</b>	
r	rh	rh	rh	r	rh	rh	rh	r	rh	rh	rh	r	rh	rh	rh	

Field	Bits	Type	Description
<b>S0SS</b>	0	rh	<b>Slice 0 shadow transfer status</b> 0 <sub>B</sub> Shadow transfer has not been requested 1 <sub>B</sub> Shadow transfer has been requested This field is cleared by HW after the requested shadow transfer has been executed.
<b>S0DSS</b>	1	rh	<b>Slice 0 Dither shadow transfer status</b> 0 <sub>B</sub> Dither shadow transfer has not been requested 1 <sub>B</sub> Dither shadow transfer has been requested This field is cleared by HW after the requested shadow transfer has been executed.

**Capture/Compare Unit 4 (CCU4)**

Field	Bits	Type	Description
<b>S0PSS</b>	2	rh	<p><b>Slice 0 Prescaler shadow transfer status</b></p> <p>0<sub>B</sub> Prescaler shadow transfer has not been requested</p> <p>1<sub>B</sub> Prescaler shadow transfer has been requested</p> <p>This field is cleared by HW after the requested shadow transfer has been executed.</p>
<b>S1SS</b>	4	rh	<p><b>Slice 1 shadow transfer status</b></p> <p>0<sub>B</sub> Shadow transfer has not been requested</p> <p>1<sub>B</sub> Shadow transfer has been requested</p> <p>This field is cleared by HW after the requested shadow transfer has been executed.</p>
<b>S1DSS</b>	5	rh	<p><b>Slice 1 Dither shadow transfer status</b></p> <p>0<sub>B</sub> Dither shadow transfer has not been requested</p> <p>1<sub>B</sub> Dither shadow transfer has been requested</p> <p>This field is cleared by HW after the requested shadow transfer has been executed.</p>
<b>S1PSS</b>	6	rh	<p><b>Slice 1 Prescaler shadow transfer status</b></p> <p>0<sub>B</sub> Prescaler shadow transfer has not been requested</p> <p>1<sub>B</sub> Prescaler shadow transfer has been requested</p> <p>This field is cleared by HW after the requested shadow transfer has been executed.</p>
<b>S2SS</b>	8	rh	<p><b>Slice 2 shadow transfer status</b></p> <p>0<sub>B</sub> Shadow transfer has not been requested</p> <p>1<sub>B</sub> Shadow transfer has been requested</p> <p>This field is cleared by HW after the requested shadow transfer has been executed.</p>
<b>S2DSS</b>	9	rh	<p><b>Slice 2 Dither shadow transfer status</b></p> <p>0<sub>B</sub> Dither shadow transfer has not been requested</p> <p>1<sub>B</sub> Dither shadow transfer has been requested</p> <p>This field is cleared by HW after the requested shadow transfer has been executed.</p>

**Capture/Compare Unit 4 (CCU4)**

Field	Bits	Type	Description
<b>S2PSS</b>	10	rh	<b>Slice 2 Prescaler shadow transfer status</b> $0_B$ Prescaler shadow transfer has not been requested $1_B$ Prescaler shadow transfer has been requested This field is cleared by HW after the requested shadow transfer has been executed.
<b>S3SS</b>	12	rh	<b>Slice 3 shadow transfer status</b> $0_B$ Shadow transfer has not been requested $1_B$ Shadow transfer has been requested This field is cleared by HW after the requested shadow transfer has been executed.
<b>S3DSS</b>	13	rh	<b>Slice 3 Dither shadow transfer status</b> $0_B$ Dither shadow transfer has not been requested $1_B$ Dither shadow transfer has been requested This field is cleared by HW after the requested shadow transfer has been executed.
<b>S3PSS</b>	14	rh	<b>Slice 3 Prescaler shadow transfer status</b> $0_B$ Prescaler shadow transfer has not been requested $1_B$ Prescaler shadow transfer has been requested This field is cleared by HW after the requested shadow transfer has been executed.
<b>CC40ST</b>	16	rh	<b>Slice 0 status bit</b>
<b>CC41ST</b>	17	rh	<b>Slice 1 status bit</b>
<b>CC42ST</b>	18	rh	<b>Slice 2 status bit</b>
<b>CC43ST</b>	19	rh	<b>Slice 3 status bit</b>
<b>0</b>	3, 7, 11, 15, [31:20]	r	<b>Reserved</b> Read always returns 0.

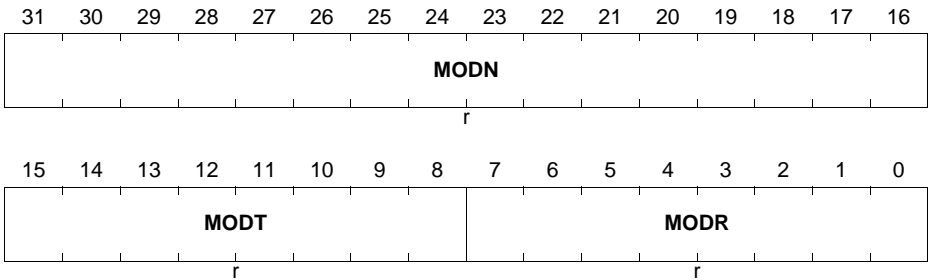
**MIDR**

This register contains the module identification number.

**Capture/Compare Unit 4 (CCU4)**

**MIDR**

**Module Identification (0080<sub>H</sub>) Reset Value: 00A6C0XX<sub>H</sub>**



Field	Bits	Type	Description
MODR	[7:0]	r	<b>Module Revision</b> This bit field indicates the revision number of the module implementation (depending on the design step). The given value of 00 <sub>H</sub> is a placeholder for the actual number.
MODT	[15:8]	r	<b>Module Type</b>
MODN	[31:16]	r	<b>Module Number</b>

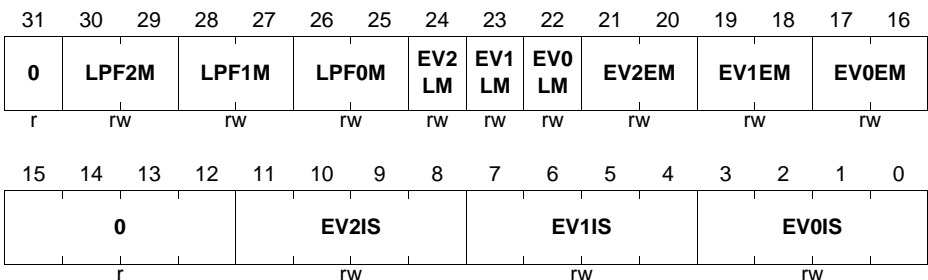
**19.7.2 Slice (CC4y) Registers**

**CC4yINS**

The register contains the configuration for the input selector.

**CC4yINS (y = 0 - 3)**

**Input Selector Configuration (0100<sub>H</sub> + 0100<sub>H</sub> \* y) Reset Value: 00000000<sub>H</sub>**



**Capture/Compare Unit 4 (CCU4)**

<b>Field</b>	<b>Bits</b>	<b>Type</b>	<b>Description</b>
<b>EV0IS</b>	[3:0]	rw	<b>Event 0 signal selection</b> This field selects which pins is used for the event 0. 0000 <sub>B</sub> CCU4x.INyA 0001 <sub>B</sub> CCU4x.INyB 0010 <sub>B</sub> CCU4x.INyC 0011 <sub>B</sub> CCU4x.INyD 0100 <sub>B</sub> CCU4x.INyE 0101 <sub>B</sub> CCU4x.INyF 0110 <sub>B</sub> CCU4x.INyG 0111 <sub>B</sub> CCU4x.INyH 1000 <sub>B</sub> CCU4x.INyI 1001 <sub>B</sub> CCU4x.INyJ 1010 <sub>B</sub> CCU4x.INyK 1011 <sub>B</sub> CCU4x.INyL 1100 <sub>B</sub> CCU4x.INyM 1101 <sub>B</sub> CCU4x.INyN 1110 <sub>B</sub> CCU4x.INyO 1111 <sub>B</sub> CCU4x.INyP
<b>EV1IS</b>	[7:4]	rw	<b>Event 1 signal selection</b> Same as EV0IS description
<b>EV2IS</b>	[11:8]	rw	<b>Event 2 signal selection</b> Same as EV0IS description
<b>EV0EM</b>	[17:16]	rw	<b>Event 0 Edge Selection</b> 00 <sub>B</sub> No action 01 <sub>B</sub> Signal active on rising edge 10 <sub>B</sub> Signal active on falling edge 11 <sub>B</sub> Signal active on both edges
<b>EV1EM</b>	[19:18]	rw	<b>Event 1 Edge Selection</b> Same as EV0EM description
<b>EV2EM</b>	[21:20]	rw	<b>Event 2 Edge Selection</b> Same as EV0EM description
<b>EV0LM</b>	22	rw	<b>Event 0 Level Selection</b> 0 <sub>B</sub> Active on HIGH level 1 <sub>B</sub> Active on LOW level
<b>EV1LM</b>	23	rw	<b>Event 1 Level Selection</b> Same as EV0LM description

**Capture/Compare Unit 4 (CCU4)**

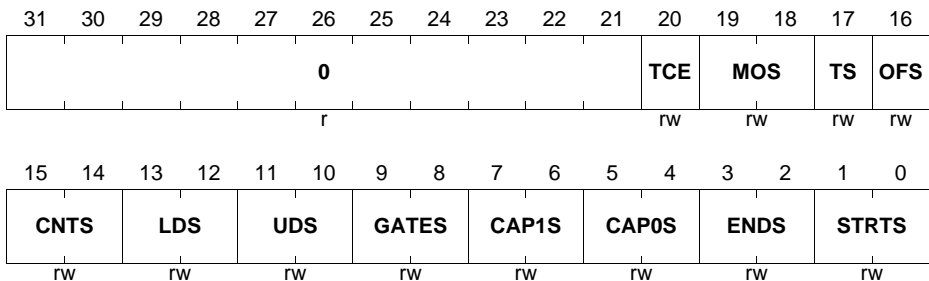
Field	Bits	Type	Description
<b>EV2LM</b>	24	rw	<b>Event 2 Level Selection</b> Same as EV0LM description
<b>LPF0M</b>	[26:25]	rw	<b>Event 0 Low Pass Filter Configuration</b> This field sets the number of consecutive counts for the Low Pass Filter of Event 0. The input signal value needs to remain stable for this number of counts ( $f_{CCU4}$ ), so that a level/transition is accepted. 00 <sub>B</sub> LPF is disabled 01 <sub>B</sub> 3 clock cycles of $f_{CCU4}$ 10 <sub>B</sub> 5 clock cycles of $f_{CCU4}$ 11 <sub>B</sub> 7 clock cycles of $f_{CCU4}$
<b>LPF1M</b>	[28:27]	rw	<b>Event 1 Low Pass Filter Configuration</b> Same description as LPF0M
<b>LPF2M</b>	[30:29]	rw	<b>Event 2 Low Pass Filter Configuration</b> Same description as LPF0M
<b>0</b>	[15:12], 31	r	<b>Reserved</b> Read always returns 0.

**CC4yCMC**

The register contains the configuration for the connection matrix.

**CC4yCMC (y = 0 - 3)**

**Connection Matrix Control**      ( $0104_H + 0100_H * y$ )      **Reset Value: 00000000<sub>H</sub>**



**Capture/Compare Unit 4 (CCU4)**

<b>Field</b>	<b>Bits</b>	<b>Type</b>	<b>Description</b>
<b>STRTS</b>	[1:0]	rw	<p><b>External Start Functionality Selector</b> Selects the Event that is going to be linked with the external start functionality.</p> <p>00<sub>B</sub> External Start Function deactivated 01<sub>B</sub> External Start Function triggered by Event 0 10<sub>B</sub> External Start Function triggered by Event 1 11<sub>B</sub> External Start Function triggered by Event 2</p>
<b>ENDS</b>	[3:2]	rw	<p><b>External Stop Functionality Selector</b> Selects the Event that is going to be linked with the external stop functionality.</p> <p>00<sub>B</sub> External Stop Function deactivated 01<sub>B</sub> External Stop Function triggered by Event 0 10<sub>B</sub> External Stop Function triggered by Event 1 11<sub>B</sub> External Stop Function triggered by Event 2</p>
<b>CAP0S</b>	[5:4]	rw	<p><b>External Capture 0 Functionality Selector</b> Selects the Event that is going to be linked with the external capture for capture registers number 1 and 0.</p> <p>00<sub>B</sub> External Capture 0 Function deactivated 01<sub>B</sub> External Capture 0 Function triggered by Event 0 10<sub>B</sub> External Capture 0 Function triggered by Event 1 11<sub>B</sub> External Capture 0 Function triggered by Event 2</p>
<b>CAP1S</b>	[7:6]	rw	<p><b>External Capture 1 Functionality Selector</b> Selects the Event that is going to be linked with the external capture for capture registers number 3 and 2.</p> <p>00<sub>B</sub> External Capture 1 Function deactivated 01<sub>B</sub> External Capture 1 Function triggered by Event 0 10<sub>B</sub> External Capture 1 Function triggered by Event 1 11<sub>B</sub> External Capture 1 Function triggered by Event 2</p>



**Capture/Compare Unit 4 (CCU4)**

<b>Field</b>	<b>Bits</b>	<b>Type</b>	<b>Description</b>
<b>GATES</b>	[9:8]	rw	<p><b>External Gate Functionality Selector</b> Selects the Event that is going to be linked with the counter gating function. This function is used to gate the timer increment/decrement procedure.</p> <p>00<sub>B</sub> External Gating Function deactivated 01<sub>B</sub> External Gating Function triggered by Event 0 10<sub>B</sub> External Gating Function triggered by Event 1 11<sub>B</sub> External Gating Function triggered by Event 2</p>
<b>UDS</b>	[11:10]	rw	<p><b>External Up/Down Functionality Selector</b> Selects the Event that is going to be linked with the Up/Down counting direction control.</p> <p>00<sub>B</sub> External Up/Down Function deactivated 01<sub>B</sub> External Up/Down Function triggered by Event 0 10<sub>B</sub> External Up/Down Function triggered by Event 1 11<sub>B</sub> External Up/Down Function triggered by Event 2</p>
<b>LDS</b>	[13:12]	rw	<p><b>External Timer Load Functionality Selector</b> Selects the Event that is going to be linked with the timer load function.</p> <p>00<sub>B</sub> - External Load Function deactivated 01<sub>B</sub> - External Load Function triggered by Event 0 10<sub>B</sub> - External Load Function triggered by Event 1 11<sub>B</sub> - External Load Function triggered by Event 2</p>
<b>CNTS</b>	[15:14]	rw	<p><b>External Count Selector</b> Selects the Event that is going to be linked with the count function. The counter is going to be increment/decremented each time that a specific transition on the event is detected.</p> <p>00<sub>B</sub> External Count Function deactivated 01<sub>B</sub> External Count Function triggered by Event 0 10<sub>B</sub> External Count Function triggered by Event 1 11<sub>B</sub> External Count Function triggered by Event 2</p>
<b>OFS</b>	16	rw	<p><b>Override Function Selector</b> This field enables the ST bit override functionality.</p> <p>0<sub>B</sub> Override functionality disabled 1<sub>B</sub> Status bit trigger override connected to Event 1; Status bit value override connected to Event 2</p>

**Capture/Compare Unit 4 (CCU4)**

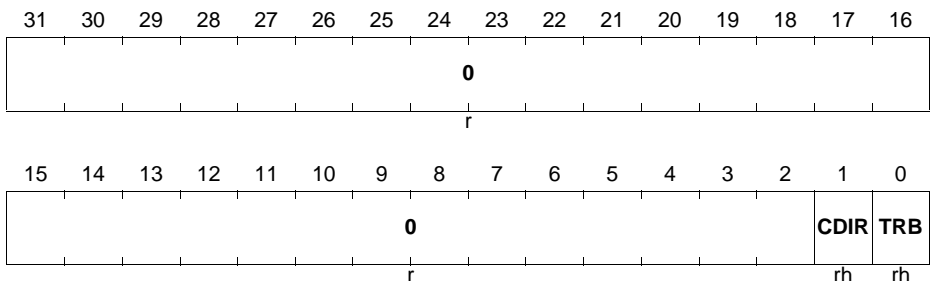
Field	Bits	Type	Description
<b>TS</b>	17	rw	<b>Trap Function Selector</b> This field enables the trap functionality. 0 <sub>B</sub> Trap function disabled 1 <sub>B</sub> TRAP function connected to Event 2
<b>MOS</b>	[19:18]	rw	<b>External Modulation Functionality Selector</b> Selects the Event that is going to be linked with the external modulation function. 00 <sub>B</sub> - Modulation Function deactivated 01 <sub>B</sub> - Modulation Function triggered by Event 0 10 <sub>B</sub> - Modulation Function triggered by Event 1 11 <sub>B</sub> - Modulation Function triggered by Event 2
<b>TCE</b>	20	rw	<b>Timer Concatenation Enable</b> This bit enables the timer concatenation with the previous slice. 0 <sub>B</sub> Timer concatenation is disabled 1 <sub>B</sub> Timer concatenation is enabled <i>Note: In CC40 this field doesn't exist. This is a read only reserved field. Read access always returns 0.</i>
<b>0</b>	[31:21]	r	<b>Reserved</b> A read always returns 0

**CC4yTCST**

The register holds the status of the timer (running/stopped) and the information about the counting direction (up/down).

**CC4yTCST (y = 0 - 3)**

**Slice Timer Status (0108<sub>H</sub> + 0100<sub>H</sub> \* y) Reset Value: 00000000<sub>H</sub>**



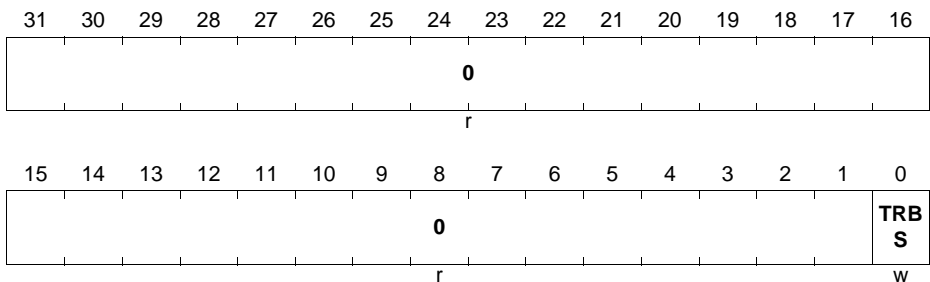
Field	Bits	Type	Description
<b>TRB</b>	0	rh	<b>Timer Run Bit</b> This field indicates if the timer is running. 0 <sub>B</sub> Timer is stopped 1 <sub>B</sub> Timer is running
<b>CDIR</b>	1	rh	<b>Timer Counting Direction</b> This field indicates if the timer is being increment or decremented 0 <sub>B</sub> Timer is counting up 1 <sub>B</sub> Timer is counting down
<b>0</b>	[31:2]	r	<b>Reserved</b> Read always returns 0

### CC4yTCSET

Through this register it is possible to start the timer.

### CC4yTCSET (y = 0 - 3)

**Slice Timer Run Set** (010C<sub>H</sub> + 0100<sub>H</sub> \* y) **Reset Value: 00000000<sub>H</sub>**



Field	Bits	Type	Description
<b>TRBS</b>	0	w	<b>Timer Run Bit set</b> Writing a 1 <sub>B</sub> into this field sets the run bit of the timer. Read always returns 0.
<b>0</b>	[31:1]	r	<b>Reserved</b> Read always returns 0

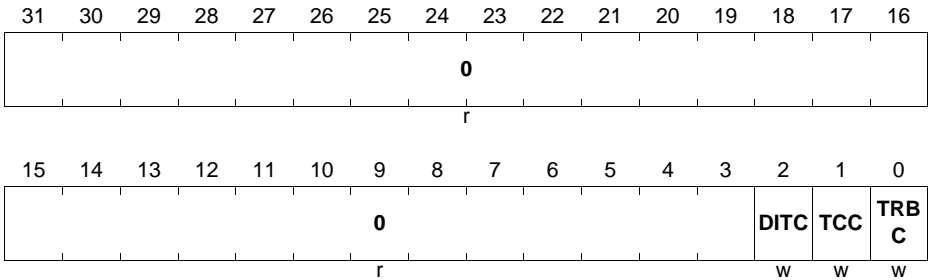
**Capture/Compare Unit 4 (CCU4)**

**CC4yTCCLR**

Through this register it is possible to stop and clear the timer, and clearing also the dither counter

**CC4yTCCLR (y = 0 - 3)**

**Slice Timer Clear** (0110<sub>H</sub> + 0100<sub>H</sub> \* y) **Reset Value: 00000000<sub>H</sub>**



Field	Bits	Type	Description
<b>TRBC</b>	0	w	<b>Timer Run Bit Clear</b> Writing a 1 <sub>B</sub> into this field clears the run bit of the timer. The timer is not cleared. Read always returns 0.
<b>TCC</b>	1	w	<b>Timer Clear</b> Writing a 1 <sub>B</sub> into this field clears the timer to 0000 <sub>H</sub> . Read always returns 0.
<b>DITC</b>	2	w	<b>Dither Counter Clear</b> Writing a 1 <sub>B</sub> into this field clears the dither counter to 0 <sub>H</sub> . Read always returns 0.
<b>0</b>	[31:3]	r	<b>Reserved</b> Read always returns 0

**CC4yTC**

This register holds the several possible configurations for the timer operation.

**Capture/Compare Unit 4 (CCU4)**

**CC4yTC (y = 0 - 3)**

**Slice Timer Control**

(0114<sub>H</sub> + 0100<sub>H</sub> \* y)

Reset Value: 00000000<sub>H</sub>

31	30	29	28	27	26	25	24	23	22	21	20	19	18	17	16
0						MCM E	EMT	EMS	TRP SW	TRP SE	0			TRA PE	FPE
r						rw	rw	rw	rw	rw	r			rw	rw
15	14	13	12	11	10	9	8	7	6	5	4	3	2	1	0
DIM	DITHE	CCS	SCE	STR M	ENDM	0	CAPC		ECM	CMO D	CLS T	TSS M	TCM		
rw	rw	rw	rw	rw	rw	r	rw		rw	rh	rw	rw	rw		

Field	Bits	Type	Description
<b>TCM</b>	0	rw	<p><b>Timer Counting Mode</b></p> <p>This field controls the actual counting scheme of the timer.</p> <p>0<sub>B</sub> Edge aligned mode 1<sub>B</sub> Center aligned mode</p> <p><i>Note: When using an external signal to control the counting direction, the counting scheme is always edge aligned.</i></p>
<b>TSSM</b>	1	rw	<p><b>Timer Single Shot Mode</b></p> <p>This field controls the single shot mode. This is applicable in edge and center aligned modes.</p> <p>0<sub>B</sub> Single shot mode is disabled 1<sub>B</sub> Single shot mode is enabled</p>
<b>CLST</b>	2	rw	<p><b>Shadow Transfer on Clear</b></p> <p>Setting this bit to 1<sub>B</sub> enables a shadow transfer when a timer clearing action is performed.</p> <p>Notice that the shadow transfer enable bitfields on the <b>GCST</b> register still need to be set to 1<sub>B</sub> via software.</p>

**Capture/Compare Unit 4 (CCU4)**

Field	Bits	Type	Description
<b>CMOD</b>	3	rh	<p><b>Capture Compare Mode</b></p> <p>This field indicates in which mode the slice is operating. The default value is compare mode. The capture mode is automatically set by the HW when an external signal is mapped to a capture trigger.</p> <p>0<sub>B</sub> Compare Mode 1<sub>B</sub> Capture Mode</p>
<b>ECM</b>	4	rw	<p><b>Extended Capture Mode</b></p> <p>This field control the Capture mode of the specific slice. It only has effect if the CMOD bit is 1<sub>B</sub>.</p> <p>0<sub>B</sub> Normal Capture Mode. Clear of the Full Flag of each capture register is done by accessing the registers individually only.</p> <p>1<sub>B</sub> Extended Capture Mode. Clear of the Full Flag of each capture register is done not only by accessing the individual registers but also by accessing the ECRD register. When reading the ECRD register, only the capture register full flag pointed by the ECRD.VPTR is cleared.</p>
<b>CAPC</b>	[6:5]	rw	<p><b>Clear on Capture Control</b></p> <p>00<sub>B</sub> Timer is never cleared on a capture event</p> <p>01<sub>B</sub> Timer is cleared on a capture event into capture registers 2 and 3. (When SCE = 1<sub>B</sub>, Timer is always cleared in a capture event)</p> <p>10<sub>B</sub> Timer is cleared on a capture event into capture registers 0 and 1. (When SCE = 1<sub>B</sub>, Timer is always cleared in a capture event)</p> <p>11<sub>B</sub> Timer is always cleared in a capture event.</p>

**Capture/Compare Unit 4 (CCU4)**

Field	Bits	Type	Description
<b>ENDM</b>	[9:8]	rw	<p><b>Extended Stop Function Control</b></p> <p>This field controls the extended functions of the external Stop signal.</p> <p>00<sub>B</sub> Clears the timer run bit only (default stop)</p> <p>01<sub>B</sub> Clears the timer only (flush)</p> <p>10<sub>B</sub> Clears the timer and run bit (flush/stop)</p> <p>11<sub>B</sub> Reserved</p> <p><i>Note: When using an external up/down signal the flush operation sets the timer with zero if the counter is counting up and with the Period value if the counter is being decremented.</i></p>
<b>STRM</b>	10	rw	<p><b>Extended Start Function Control</b></p> <p>This field controls the extended functions of the external Start signal.</p> <p>0<sub>B</sub> Sets run bit only (default start)</p> <p>1<sub>B</sub> Clears the timer and sets run bit (flush/start)</p> <p><i>Note: When using an external up/down signal the flush operation sets the timer with zero if the counter is being incremented and with the Period value if the counter is being decremented.</i></p>
<b>SCE</b>	11	rw	<p><b>Equal Capture Event enable</b></p> <p>0<sub>B</sub> Capture into <b>CC4yC0V/CC4yC1V</b> registers control by CCycapt0 and capture into <b>CC4yC3V/CC4yC2V</b> control by CCycapt1</p> <p>1<sub>B</sub> Capture into <b>CC4yC0V/CC4yC1V</b> and <b>CC4yC3V/CC4yC2V</b> control by CCycapt1</p>
<b>CCS</b>	12	rw	<p><b>Continuous Capture Enable</b></p> <p>0<sub>B</sub> The capture into a specific capture register is done with the rules linked with the full flags, described at <b>Section 19.2.7.6</b>.</p> <p>1<sub>B</sub> The capture into the capture registers is always done regardless of the full flag status (even if the register has not been read back).</p>

**Capture/Compare Unit 4 (CCU4)**

Field	Bits	Type	Description
<b>DITHE</b>	[14:13]	rw	<p><b>Dither Enable</b> This field controls the dither mode for the slice. See <a href="#">Section 19.2.10</a>.</p> <p>00<sub>B</sub> Dither is disabled 01<sub>B</sub> Dither is applied to the Period 10<sub>B</sub> Dither is applied to the Compare 11<sub>B</sub> Dither is applied to the Period and Compare</p>
<b>DIM</b>	15	rw	<p><b>Dither input selector</b> This fields selects if the dither control signal is connected to the dither logic of the specific slice of is connected to the dither logic of slice 0. Notice that even if this field is set to 1<sub>B</sub>, the field DITHE still needs to be programmed.</p> <p>0<sub>B</sub> Slice is using its own dither unit 1<sub>B</sub> Slice is connected to the dither unit of slice 0.</p>
<b>FPE</b>	16	rw	<p><b>Floating Prescaler enable</b> Setting this bit to 1<sub>B</sub> enables the floating prescaler mode.</p> <p>0<sub>B</sub> Floating prescaler mode is disabled 1<sub>B</sub> Floating prescaler mode is enabled</p>
<b>TRAPE</b>	17	rw	<p><b>TRAP enable</b> Setting this bit to 1<sub>B</sub> enables the TRAP action at the output pin. After mapping an external signal to the TRAP functionality, the user must set this field to 1<sub>B</sub> to activate the effect of the TRAP on the output pin. Writing a 0<sub>B</sub> into this field disables the effect of the TRAP function regardless of the state of the input signal.</p> <p>0<sub>B</sub> TRAP functionality has no effect on the output 1<sub>B</sub> TRAP functionality affects the output</p>
<b>TRPSE</b>	21	rw	<p><b>TRAP Synchronization Enable</b> Writing a 1<sub>B</sub> into this bit enables a synchronous exiting with the PWM signal of the trap state.</p> <p>0<sub>B</sub> Exiting from TRAP state isn't synchronized with the PWM signal 1<sub>B</sub> Exiting from TRAP state is synchronized with the PWM signal</p>



**Capture/Compare Unit 4 (CCU4)**

Field	Bits	Type	Description
<b>TRPSW</b>	22	rw	<p><b>TRAP State Clear Control</b></p> <p>0<sub>B</sub> The slice exits the TRAP state automatically when the TRAP condition is not present</p> <p>1<sub>B</sub> The TRAP state can only be exited by a SW request.</p>
<b>EMS</b>	23	rw	<p><b>External Modulation Synchronization</b></p> <p>Setting this bit to 1<sub>B</sub> enables the synchronization of the external modulation functionality with the PWM period.</p> <p>0<sub>B</sub> External Modulation functionality is not synchronized with the PWM signal</p> <p>1<sub>B</sub> External Modulation functionality is synchronized with the PWM signal</p>
<b>EMT</b>	24	rw	<p><b>External Modulation Type</b></p> <p>This field selects if the external modulation event is clearing the CC4yST bit or if is gating the outputs.</p> <p>0<sub>B</sub> External Modulation functionality is clearing the CC4yST bit.</p> <p>1<sub>B</sub> External Modulation functionality is gating the outputs.</p>
<b>MCME</b>	25	rw	<p><b>Multi Channel Mode Enable</b></p> <p>0<sub>B</sub> Multi Channel Mode is disabled</p> <p>1<sub>B</sub> Multi Channel Mode is enabled</p>
<b>0</b>	7, [20:18] , [31:26]	r	<p><b>Reserved</b></p> <p>Read always returns 0</p>

### CC4yPSL

This register holds the configuration for the output passive level control.

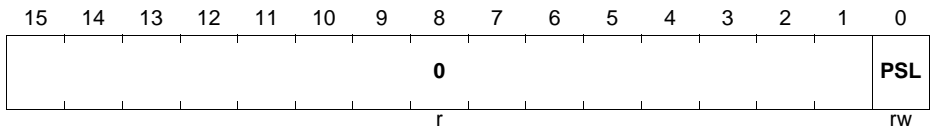
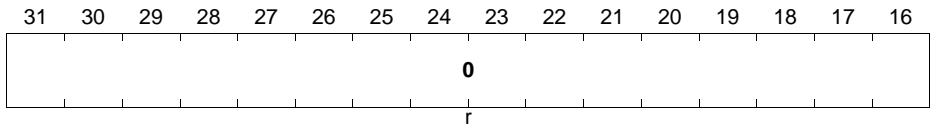
**Capture/Compare Unit 4 (CCU4)**

**CC4yPSL (y = 0 - 3)**

**Passive Level Config**

**(0118<sub>H</sub> + 0100<sub>H</sub> \* y)**

**Reset Value: 00000000<sub>H</sub>**



Field	Bits	Type	Description
PSL	0	rw	<b>Output Passive Level</b> This field controls the passive level of the output pin. 0 <sub>B</sub> Passive Level is LOW 1 <sub>B</sub> Passive Level is HIGH A write always addresses the shadow register, while a read always returns the current used value.
0	[31:1]	r	<b>Reserved</b> A read access always returns 0

**CC4yDIT**

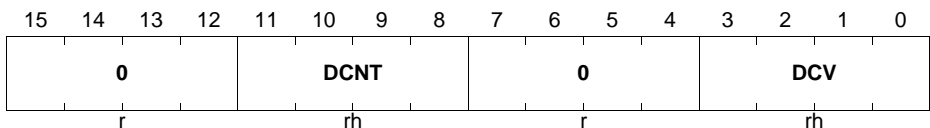
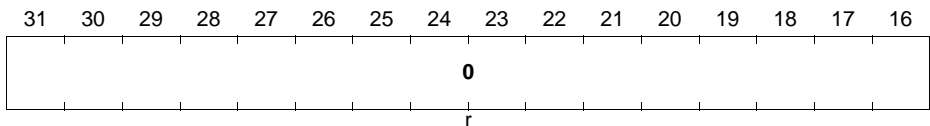
This register holds the current dither compare and dither counter values.

**CC4yDIT (y = 0 - 3)**

**Dither Config**

**(011C<sub>H</sub> + 0100<sub>H</sub> \* y)**

**Reset Value: 00000000<sub>H</sub>**



**Capture/Compare Unit 4 (CCU4)**

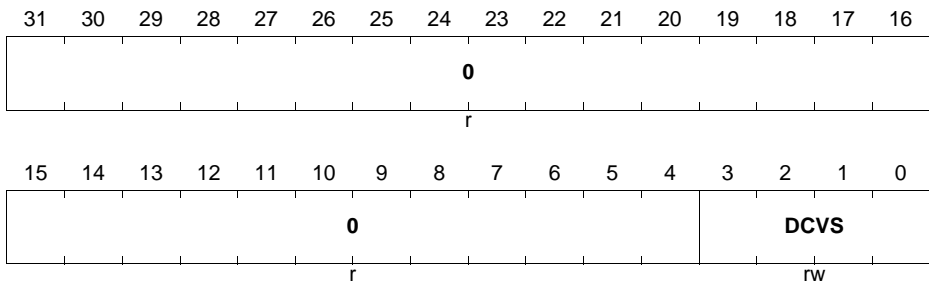
Field	Bits	Type	Description
<b>DCV</b>	[3:0]	rh	<b>Dither compare Value</b> This field contains the value used for the dither comparison. This value is updated when a shadow transfer occurs with the <b>CC4yDITS.DCVS</b> .
<b>DCNT</b>	[11:8]	rh	<b>Dither counter actual value</b>
<b>0</b>	[7:4], [31:12]	r	<b>Reserved</b> Read always returns 0.

**CC4yDITS**

This register contains the value that is going to be loaded into the **CC4yDIT.DCV** when the next shadow transfer occurs.

**CC4yDITS (y = 0 - 3)**

**Dither Shadow Register**                      **(0120<sub>H</sub> + 0100<sub>H</sub> \* y)**                      **Reset Value: 00000000<sub>H</sub>**



Field	Bits	Type	Description
<b>DCVS</b>	[3:0]	rw	<b>Dither Shadow Compare Value</b> This field contains the value that is going to be set on the dither compare value, <b>CC4yDIT.DCV</b> , within the next shadow transfer.
<b>0</b>	[31:4]	r	<b>Reserved</b> Read always returns 0.

**CC4yPSC**

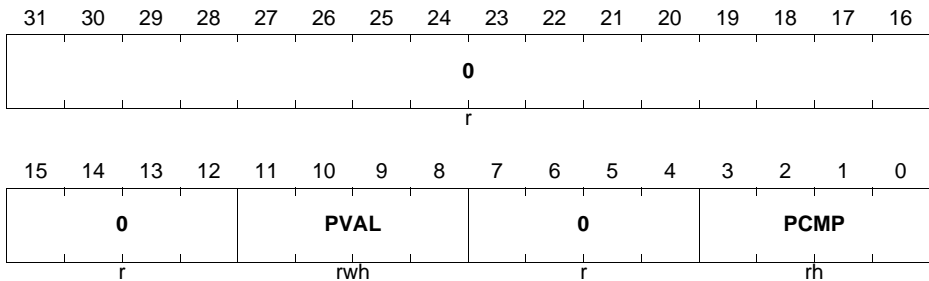
This register contains the value that is loaded into the prescaler during restart.



**Capture/Compare Unit 4 (CCU4)**

**CC4yFPC (y = 0 - 3)**

**Floating Prescaler Control**       $(0128_H + 0100_H * y)$       **Reset Value: 00000000<sub>H</sub>**



Field	Bits	Type	Description
<b>PCMP</b>	[3:0]	rh	<b>Floating Prescaler Compare Value</b> This field contains comparison value used in floating prescaler mode. The comparison is triggered by the Timer Compare match event. See <a href="#">Section 19.2.11.2</a> .
<b>PVAL</b>	[11:8]	rwh	<b>Actual Prescaler Value</b> See <a href="#">Table 19-7</a> . Writing into this register is only possible when the prescaler is stopped. When the floating prescaler mode is not used, this value is equal to the <a href="#">CC4yPSC.PSIV</a> .
<b>0</b>	[7:4], [15:12], [31:16]	r	<b>Reserved</b> Read always returns 0.

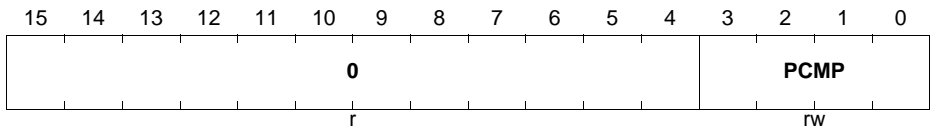
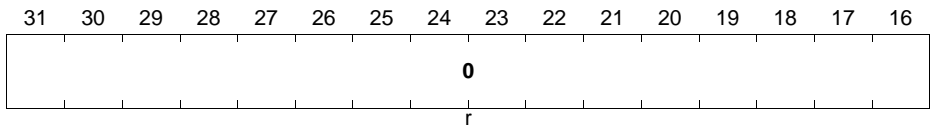
**CC4yFPCS**

This register contains the value that is going to be transferred to the [CC4yFPC.PCMP](#) field within the next shadow transfer update.

**Capture/Compare Unit 4 (CCU4)**

**CC4yFPCS (y = 0 - 3)**

**Floating Prescaler Shadow**       $(012C_H + 0100_H * y)$       **Reset Value: 00000000<sub>H</sub>**



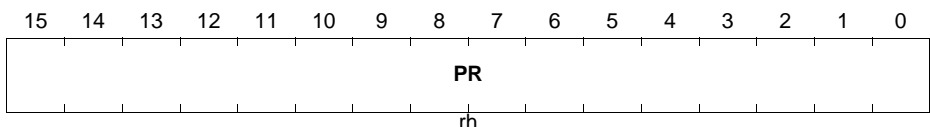
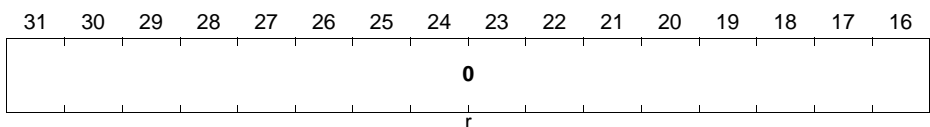
Field	Bits	Type	Description
<b>PCMP</b>	[3:0]	rw	<b>Floating Prescaler Shadow Compare Value</b> This field contains the value that is going to be set on the <b>CC4yFPC.PCMP</b> within the next shadow transfer. See <a href="#">Table 19-7</a> .
<b>0</b>	[31:4]	r	<b>Reserved</b> Read always returns 0.

**CC4yPR**

This register contains the actual value for the timer period.

**CC4yPR (y = 0 - 3)**

**Timer Period Value**       $(0130_H + 0100_H * y)$       **Reset Value: 00000000<sub>H</sub>**



**Capture/Compare Unit 4 (CCU4)**

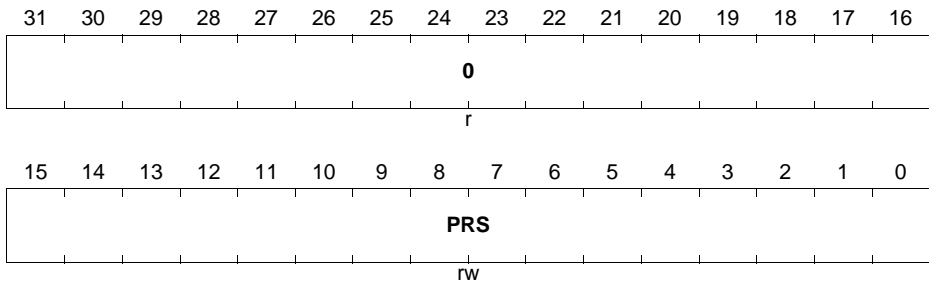
Field	Bits	Type	Description
<b>PR</b>	[15:0]	rh	<b>Period Register</b> Contains the value of the timer period. <i>Note: In Capture Mode when a external signal is selected for capturing the timer value into the capture registers 2 and 3, PR is not accessible for writing. A read always returns 0.</i>
<b>0</b>	[31:16]	r	<b>Reserved</b> A read always returns 0.

**CC4yPRS**

This register contains the value for the timer period that is going to be transferred into the **CC4yPR.PR** field when the next shadow transfer occurs.

**CC4yPRS (y = 0 - 3)**

**Timer Shadow Period Value**     **(0134<sub>H</sub> + 0100<sub>H</sub> \* y)**     **Reset Value: 00000000<sub>H</sub>**



Field	Bits	Type	Description
<b>PRS</b>	[15:0]	rw	<b>Period Register</b> Contains the value of the timer period, that is going to be passed into the <b>CC4yPR.PR</b> field when the next shadow transfer occurs. <i>Note: In Capture Mode when a external signal is selected for capturing the timer value into the capture registers 2 and 3, the PRS is not accessible for writing. A read always returns 0.</i>

**Capture/Compare Unit 4 (CCU4)**

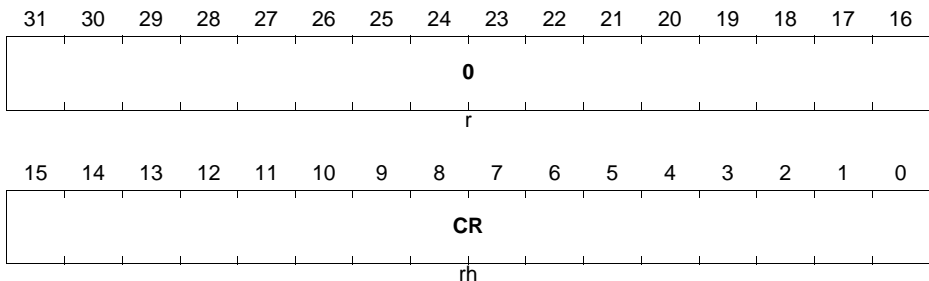
Field	Bits	Type	Description
<b>0</b>	[31:16]	r	<b>Reserved</b> A read always returns 0.

**CC4yCR**

This register contains the value for the timer comparison.

**CC4yCR (y = 0 - 3)**

**Timer Compare Value**                      **(0138<sub>H</sub> + 0100<sub>H</sub> \* y)**                      **Reset Value: 00000000<sub>H</sub>**



Field	Bits	Type	Description
<b>CR</b>	[15:0]	rh	<b>Compare Register</b> Contains the value for the timer comparison. <i>Note: In Capture Mode when a external signal is selected for capturing the timer value into the capture registers 0 and 1, a read always returns 0.</i>
<b>0</b>	[31:16]	r	<b>Reserved</b> A read always returns 0.

**CC4yCRS**

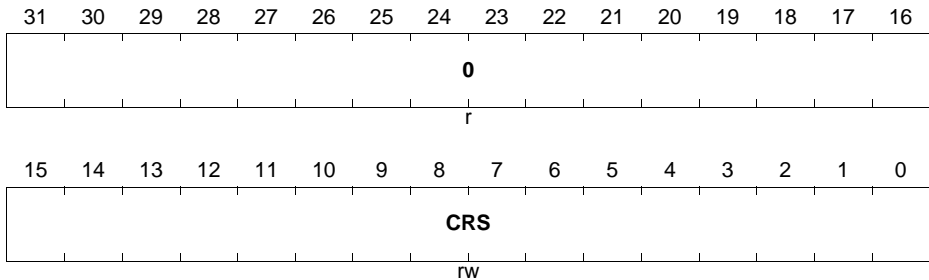
This register contains the value that is going to be loaded into the **CC4yCR.CR** field when the next shadow transfer occurs.



**Capture/Compare Unit 4 (CCU4)**

**CC4yCRS (y = 0 - 3)**

**Timer Shadow Compare Value (013C<sub>H</sub> + 0100<sub>H</sub> \* y)      Reset Value: 00000000<sub>H</sub>**



Field	Bits	Type	Description
<b>CRS</b>	[15:0]	rw	<p><b>Compare Register</b></p> <p>Contains the value for the timer comparison, that is going to be passed into the <b>CC4yCR.CR</b> field when the next shadow transfer occurs.</p> <p><i>Note: In Capture Mode when a external signal is selected for capturing the timer value into the capture registers 0 and 1, a read always returns 0.</i></p>
<b>0</b>	[31:16]	r	<p><b>Reserved</b></p> <p>A read always returns 0.</p>

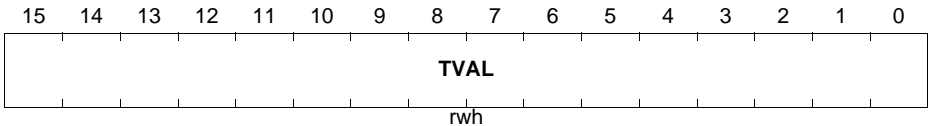
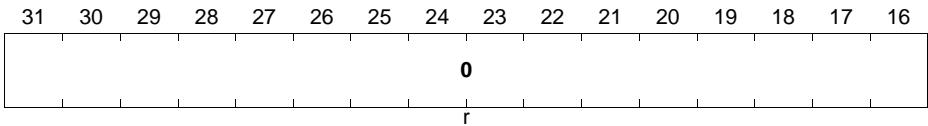
**CC4yTIMER**

This register contains the current value of the timer.

**Capture/Compare Unit 4 (CCU4)**

**CC4yTIMER (y = 0 - 3)**

**Timer Value**  $(0170_H + 0100_H * y)$  **Reset Value: 00000000<sub>H</sub>**



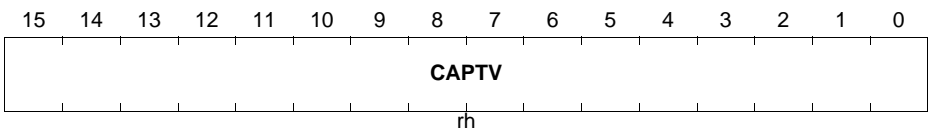
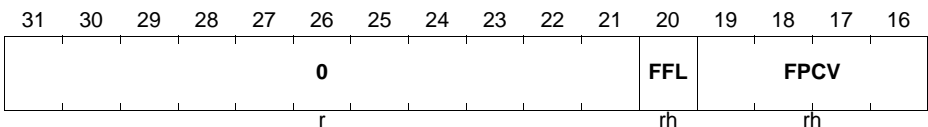
Field	Bits	Type	Description
TVAL	[15:0]	rwh	<b>Timer Value</b> This field contains the actual value of the timer. A write access is only possible when the timer is stopped.
0	[31:16]	r	<b>Reserved</b> A read access always returns 0

**CC4yC0V**

This register contains the values associated with the Capture 0 field.

**CC4yC0V (y = 0 - 3)**

**Capture Register 0**  $(0174_H + 0100_H * y)$  **Reset Value: 00000000<sub>H</sub>**



**Capture/Compare Unit 4 (CCU4)**

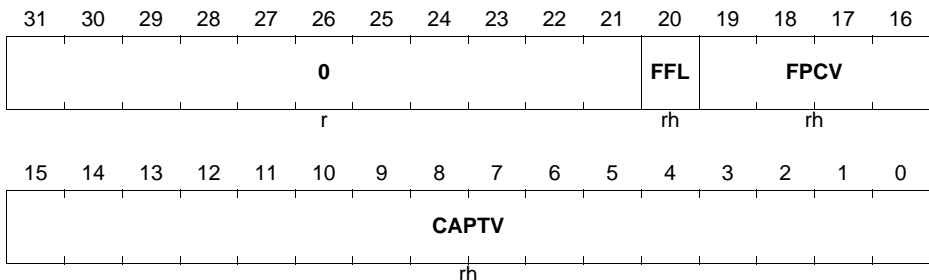
Field	Bits	Type	Description
<b>CAPT</b>	[15:0]	rh	<b>Capture Value</b> This field contains the capture register 0 value. See <a href="#">Figure 19-26</a> . In compare mode a read access always returns 0.
<b>FPCV</b>	[19:16]	rh	<b>Prescaler Value</b> This field contains the prescaler value at the time of the capture event into the capture register 0. In compare mode a read access always returns 0.
<b>FFL</b>	20	rh	<b>Full Flag</b> This bit indicates if a new value was capture into the capture register 0 after the last read access. See <a href="#">Figure 19-26</a> . In compare mode a read access always returns 0. $0_B$ No new value was captured into the specific capture register $1_B$ A new value was captured into the specific register
<b>0</b>	[31:21]	r	<b>Reserved</b> A read always returns 0

**CC4yC1V**

This register contains the values associated with the Capture 1 field.

**CC4yC1V (y = 0 - 3)**

**Capture Register 1**                      **(0178<sub>H</sub> + 0100<sub>H</sub> \* y)**                      **Reset Value: 00000000<sub>H</sub>**



**Capture/Compare Unit 4 (CCU4)**

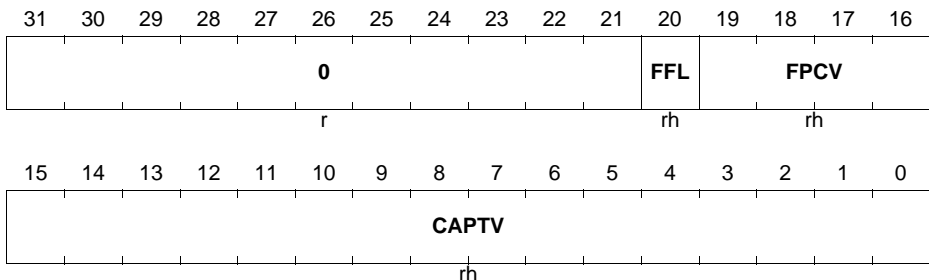
Field	Bits	Type	Description
<b>CAPTV</b>	[15:0]	rh	<b>Capture Value</b> This field contains the capture register 1 value. See <a href="#">Figure 19-26</a> . In compare mode a read access always returns 0.
<b>FPCV</b>	[19:16]	rh	<b>Prescaler Value</b> This field contains the prescaler value at the time of the capture event into the capture register 1. In compare mode a read access always returns 0.
<b>FFL</b>	20	rh	<b>Full Flag</b> This bit indicates if a new value was capture into the capture register 1 after the last read access. See <a href="#">Figure 19-26</a> . In compare mode a read access always returns 0. $0_B$ No new value was captured into the specific capture register $1_B$ A new value was captured into the specific register
<b>0</b>	[31:21]	r	<b>Reserved</b> A read always returns 0

**CC4yC2V**

This register contains the values associated with the Capture 2 field.

**CC4yC2V (y = 0 - 3)**

**Capture Register 2**                      **( $017C_H + 0100_H * y$ )**                      **Reset Value: 00000000<sub>H</sub>**



**Capture/Compare Unit 4 (CCU4)**

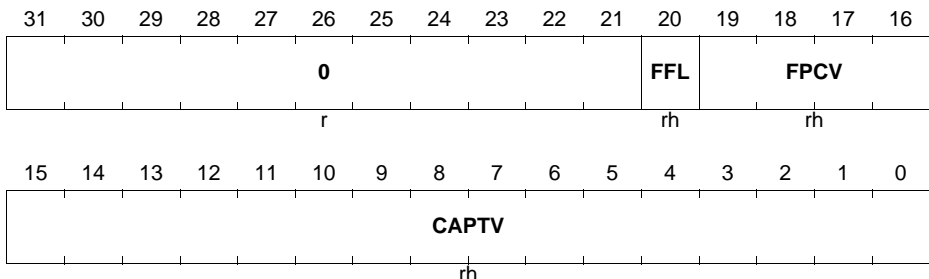
Field	Bits	Type	Description
<b>CAPTV</b>	[15:0]	rh	<b>Capture Value</b> This field contains the capture register 2 value. See <a href="#">Figure 19-26</a> . In compare mode a read access always returns 0.
<b>FPCV</b>	[19:16]	rh	<b>Prescaler Value</b> This field contains the prescaler value at the time of the capture event into the capture register 2. In compare mode a read access always returns 0.
<b>FFL</b>	20	rh	<b>Full Flag</b> This bit indicates if a new value was capture into the capture register 2 after the last read access. See <a href="#">Figure 19-26</a> . In compare mode a read access always returns 0. $0_B$ No new value was captured into the specific capture register $1_B$ A new value was captured into the specific register
<b>0</b>	[31:21]	r	<b>Reserved</b> A read always returns 0

**CC4yC3V**

This register contains the values associated with the Capture 3 field.

**CC4yC3V (y = 0 - 3)**

**Capture Register 3**                      **(0180<sub>H</sub> + 0100<sub>H</sub> \* y)**                      **Reset Value: 00000000<sub>H</sub>**



**Capture/Compare Unit 4 (CCU4)**

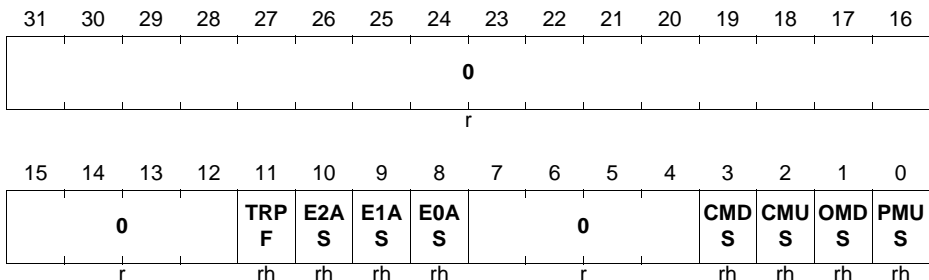
Field	Bits	Type	Description
<b>CAPTV</b>	[15:0]	rh	<b>Capture Value</b> This field contains the capture register 3 value. See <a href="#">Figure 19-26</a> . In compare mode a read access always returns 0.
<b>FPCV</b>	[19:16]	rh	<b>Prescaler Value</b> This field contains the prescaler value at the time of the capture event into the capture register 3. In compare mode a read access always returns 0.
<b>FFL</b>	20	rh	<b>Full Flag</b> This bit indicates if a new value was capture into the capture register 3 after the last read access. See <a href="#">Figure 19-26</a> . In compare mode a read access always returns 0. 0 <sub>B</sub> No new value was captured into the specific capture register 1 <sub>B</sub> A new value was captured into the specific register
<b>0</b>	[31:21]	r	<b>Reserved</b> A read always returns 0

**CC4yINTS**

This register contains the status of all interrupt sources.

**CC4yINTS (y = 0 - 3)**

**Interrupt Status** (01A0<sub>H</sub> + 0100<sub>H</sub> \* y) **Reset Value: 00000000<sub>H</sub>**



**Capture/Compare Unit 4 (CCU4)**

Field	Bits	Type	Description
<b>PMUS</b>	0	rh	<b>Period Match while Counting Up</b> $0_B$ Period match while counting up not detected $1_B$ Period match while counting up detected
<b>OMDS</b>	1	rh	<b>One Match while Counting Down</b> $0_B$ One match while counting down not detected $1_B$ One match while counting down detected
<b>CMUS</b>	2	rh	<b>Compare Match while Counting Up</b> $0_B$ Compare match while counting up not detected $1_B$ Compare match while counting up detected
<b>CMDS</b>	3	rh	<b>Compare Match while Counting Down</b> $0_B$ Compare match while counting down not detected $1_B$ Compare match while counting down detected
<b>E0AS</b>	8	rh	<b>Event 0 Detection Status</b> Depending on the user selection on the <b>CC4yINS.EV0EM</b> , this bit can be set when a rising, falling or both transitions are detected. $0_B$ Event 0 not detected $1_B$ Event 0 detected
<b>E1AS</b>	9	rh	<b>Event 1 Detection Status</b> Depending on the user selection on the <b>CC4yINS.EV1EM</b> , this bit can be set when a rising, falling or both transitions are detected. $0_B$ Event 1 not detected $1_B$ Event 1 detected
<b>E2AS</b>	10	rh	<b>Event 2 Detection Status</b> Depending on the user selection on the <b>CC4yINS.EV1EM</b> , this bit can be set when a rising, falling or both transitions are detected. $0_B$ Event 2 not detected $1_B$ Event 2 detected  <i>Note: If this event is linked with the TRAP function, this field is automatically cleared when the slice exits the Trap State.</i>
<b>TRPF</b>	11	rh	<b>Trap Flag Status</b> This field contains the status of the Trap Flag.

**Capture/Compare Unit 4 (CCU4)**

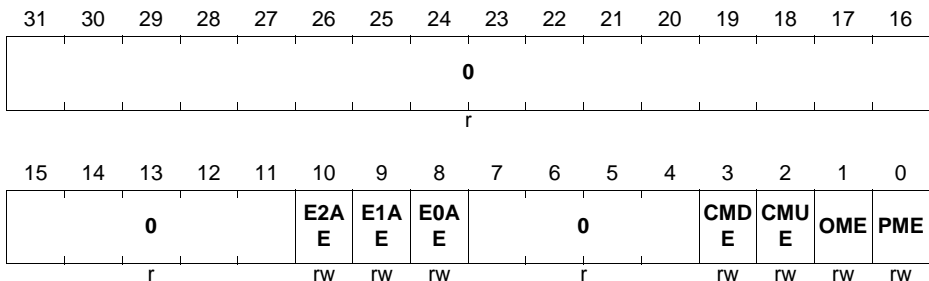
Field	Bits	Type	Description
0	[7:4], [31:12]	r	<b>Reserved</b> A read always returns 0.

**CC4yINTE**

Through this register it is possible to enable or disable the specific interrupt source(s).

**CC4yINTE (y = 0 - 3)**

**Interrupt Enable Control** (01A4<sub>H</sub> + 0100<sub>H</sub> \* y) **Reset Value: 00000000<sub>H</sub>**



Field	Bits	Type	Description
<b>PME</b>	0	rw	<b>Period match while counting up enable</b> Setting this bit to 1 <sub>B</sub> enables the generation of an interrupt pulse every time a period match while counting up occurs. 0 <sub>B</sub> Period Match interrupt is disabled 1 <sub>B</sub> Period Match interrupt is enabled
<b>OME</b>	1	rw	<b>One match while counting down enable</b> Setting this bit to 1 <sub>B</sub> enables the generation of an interrupt pulse every time an one match while counting down occurs. 0 <sub>B</sub> One Match interrupt is disabled 1 <sub>B</sub> One Match interrupt is enabled



**Capture/Compare Unit 4 (CCU4)**

Field	Bits	Type	Description
<b>CMUE</b>	2	rw	<p><b>Compare match while counting up enable</b> Setting this bit to 1<sub>B</sub> enables the generation of an interrupt pulse every time a compare match while counting up occurs.</p> <p>0<sub>B</sub> Compare Match while counting up interrupt is disabled</p> <p>1<sub>B</sub> Compare Match while counting up interrupt is enabled</p>
<b>CMDE</b>	3	rw	<p><b>Compare match while counting down enable</b> Setting this bit to 1<sub>B</sub> enables the generation of an interrupt pulse every time a compare match while counting down occurs.</p> <p>0<sub>B</sub> Compare Match while counting down interrupt is disabled</p> <p>1<sub>B</sub> Compare Match while counting down interrupt is enabled</p>
<b>E0AE</b>	8	rw	<p><b>Event 0 interrupt enable</b> Setting this bit to 1<sub>B</sub> enables the generation of an interrupt pulse every time that Event 0 is detected.</p> <p>0<sub>B</sub> Event 0 detection interrupt is disabled</p> <p>1<sub>B</sub> Event 0 detection interrupt is enabled</p>
<b>E1AE</b>	9	rw	<p><b>Event 1 interrupt enable</b> Setting this bit to 1<sub>B</sub> enables the generation of an interrupt pulse every time that Event 1 is detected.</p> <p>0<sub>B</sub> Event 1 detection interrupt is disabled</p> <p>1<sub>B</sub> Event 1 detection interrupt is enabled</p>
<b>E2AE</b>	10	rw	<p><b>Event 2 interrupt enable</b> Setting this bit to 1<sub>B</sub> enables the generation of an interrupt pulse every time that Event 2 is detected.</p> <p>0<sub>B</sub> Event 2 detection interrupt is disabled</p> <p>1<sub>B</sub> Event 2 detection interrupt is enabled</p>
<b>0</b>	[7:4], [31:11]	r	<p><b>Reserved</b> A read always returns 0</p>

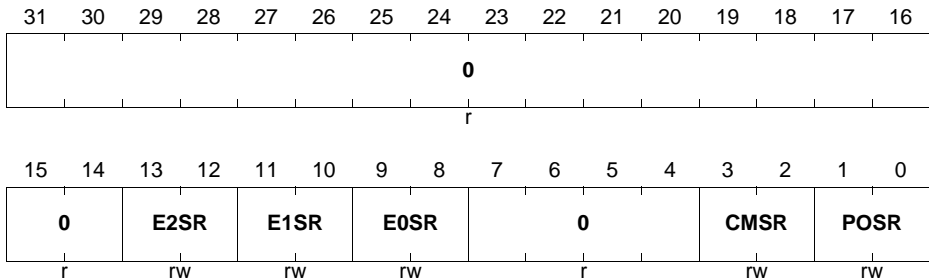
### CC4ySRS

Through this register it is possible to select to which service request line each interrupt source is forwarded.

**Capture/Compare Unit 4 (CCU4)**

**CC4ySRS (y = 0 - 3)**

**Service Request Selector**      **(01A8<sub>H</sub> + 0100<sub>H</sub> \* y)**      **Reset Value: 00000000<sub>H</sub>**



Field	Bits	Type	Description
<b>POSR</b>	[1:0]	rw	<p><b>Period/One match Service request selector</b></p> <p>This field selects to which slice Service request line, the interrupt(s) generated by the Period match while counting up and One match while counting down are going to be forward.</p> <p>00<sub>B</sub> Forward to CC4ySR0            01<sub>B</sub> Forward to CC4ySR1            10<sub>B</sub> Forward to CC4ySR2            11<sub>B</sub> Forward to CC4ySR3</p>
<b>CMSR</b>	[3:2]	rw	<p><b>Compare match Service request selector</b></p> <p>This field selects to which slice Service request line, the interrupt(s) generated by the Compare match while counting up and Compare match while counting down are going to be forward.</p> <p>00<sub>B</sub> Forward to CC4ySR0            01<sub>B</sub> Forward to CC4ySR1            10<sub>B</sub> Forward to CC4ySR2            11<sub>B</sub> Forward to CC4ySR3</p>
<b>E0SR</b>	[9:8]	rw	<p><b>Event 0 Service request selector</b></p> <p>This field selects to which slice Service request line, the interrupt generated by the Event 0 detection is going to be forward.</p> <p>00<sub>B</sub> Forward to CC4ySR0            01<sub>B</sub> Forward to CC4ySR1            10<sub>B</sub> Forward to CC4ySR2            11<sub>B</sub> Forward to CC4ySR3</p>

**Capture/Compare Unit 4 (CCU4)**

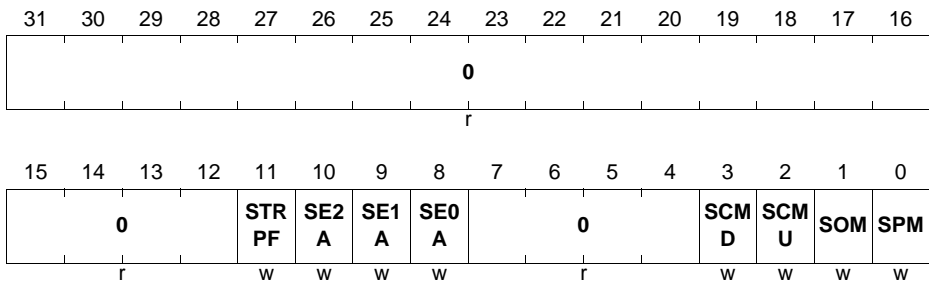
Field	Bits	Type	Description
<b>E1SR</b>	[11:10]	rw	<b>Event 1 Service request selector</b> This field selects to which slice Service request line, the interrupt generated by the Event 1 detection is going to be forward. 00 <sub>B</sub> Forward to CC4ySR0 01 <sub>B</sub> Forward to CC4ySR1 10 <sub>B</sub> Forward to CC4ySR2 11 <sub>B</sub> Forward to CC4ySR3
<b>E2SR</b>	[13:12]	rw	<b>Event 2 Service request selector</b> This field selects to which slice Service request line, the interrupt generated by the Event 2 detection is going to be forward. 00 <sub>B</sub> Forward to CC4ySR0 01 <sub>B</sub> Forward to CC4ySR1 10 <sub>B</sub> Forward to CC4ySR2 11 <sub>B</sub> Forward to CC4ySR3
<b>0</b>	[7:4], [31:14]	r	<b>Reserved</b> Read always returns 0.

**CC4ySWS**

Through this register it is possible for the SW to set a specific interrupt status flag.

**CC4ySWS (y = 0 - 3)**

**Interrupt Status Set** (01AC<sub>H</sub> + 0100<sub>H</sub> \* y) **Reset Value: 00000000<sub>H</sub>**



**Capture/Compare Unit 4 (CCU4)**

Field	Bits	Type	Description
<b>SPM</b>	0	w	<b>Period match while counting up set</b> Writing a 1 <sub>B</sub> into this field sets the <b>CC4yINTS.PMUS</b> bit. An interrupt pulse is generated if the source is enabled. A read always returns 0.
<b>SOM</b>	1	w	<b>One match while counting down set</b> Writing a 1 <sub>B</sub> into this bit sets the <b>CC4yINTS.OMDS</b> bit. An interrupt pulse is generated if the source is enabled. A read always returns 0.
<b>SCMU</b>	2	w	<b>Compare match while counting up set</b> Writing a 1 <sub>B</sub> into this field sets the <b>CC4yINTS.CMUS</b> bit. An interrupt pulse is generated if the source is enabled. A read always returns 0.
<b>SCMD</b>	3	w	<b>Compare match while counting down set</b> Writing a 1 <sub>B</sub> into this bit sets the <b>CC4yINTS.CMDS</b> bit. An interrupt pulse is generated if the source is enabled. A read always returns 0.
<b>SE0A</b>	8	w	<b>Event 0 detection set</b> Writing a 1 <sub>B</sub> into this bit sets the <b>CC4yINTS.E0AS</b> bit. An interrupt pulse is generated if the source is enabled. A read always returns 0.
<b>SE1A</b>	9	w	<b>Event 1 detection set</b> Writing a 1 <sub>B</sub> into this bit sets the <b>CC4yINTS.E1AS</b> bit. An interrupt pulse is generated if the source is enabled. A read always returns 0.
<b>SE2A</b>	10	w	<b>Event 2 detection set</b> Writing a 1 <sub>B</sub> into this bit sets the <b>CC4yINTS.E2AS</b> bit. An interrupt pulse is generated if the source is enabled. A read always returns 0.
<b>STRPF</b>	11	w	<b>Trap Flag status set</b> Writing a 1 <sub>B</sub> into this bit sets the <b>CC4yINTS.TRPF</b> bit. A read always returns 0.
<b>0</b>	[7:4], [31:12]	r	<b>Reserved</b> Read always returns 0

**CC4ySWR**

Through this register it is possible for the SW to clear a specific interrupt status flag.

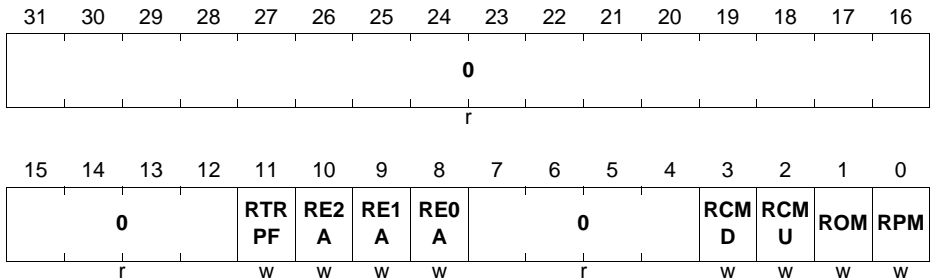
**Capture/Compare Unit 4 (CCU4)**

**CC4ySWR (y = 0 - 3)**

**Interrupt Status Clear**

**(01B0<sub>H</sub> + 0100<sub>H</sub> \* y)**

**Reset Value: 00000000<sub>H</sub>**



Field	Bits	Type	Description
RPM	0	w	<b>Period match while counting up clear</b> Writing a 1 <sub>B</sub> into this field clears the <b>CC4yINTS</b> .PMUS bit. A read always returns 0.
ROM	1	w	<b>One match while counting down clear</b> Writing a 1 <sub>B</sub> into this bit clears the <b>CC4yINTS</b> .OMDS bit. A read always returns 0.
RCMU	2	w	<b>Compare match while counting up clear</b> Writing a 1 <sub>B</sub> into this field clears the <b>CC4yINTS</b> .CMUS bit. A read always returns 0.
RCMD	3	w	<b>Compare match while counting down clear</b> Writing a 1 <sub>B</sub> into this bit clears the <b>CC4yINTS</b> .CMDS bit. A read always returns 0.
RE0A	8	w	<b>Event 0 detection clear</b> Writing a 1 <sub>B</sub> into this bit clears the <b>CC4yINTS</b> .E0AS bit. A read always returns 0.
RE1A	9	w	<b>Event 1 detection clear</b> Writing a 1 <sub>B</sub> into this bit clears the <b>CC4yINTS</b> .E1AS bit. A read always returns 0.
RE2A	10	w	<b>Event 2 detection clear</b> Writing a 1 <sub>B</sub> into this bit clears the <b>CC4yINTS</b> .E2AS bit. A read always returns 0.

**Capture/Compare Unit 4 (CCU4)**

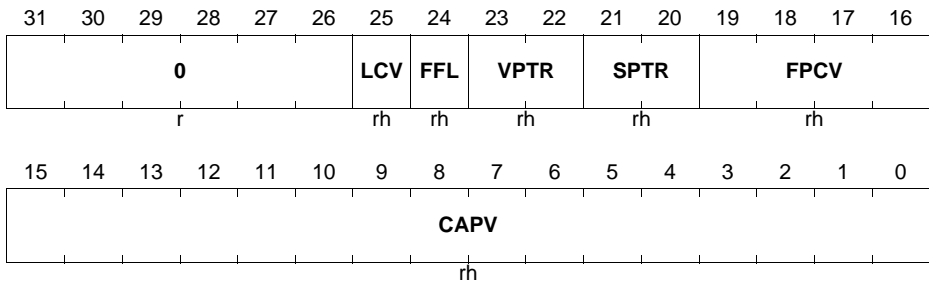
Field	Bits	Type	Description
<b>RTRPF</b>	11	w	<b>Trap Flag status clear</b> Writing a 1 <sub>B</sub> into this bit clears the <b>CC4yINTS</b> .TRPF bit. Not valid if <b>CC4yTC</b> .TRPEN = 1 <sub>B</sub> and the Trap State is still active. A read always returns 0.
<b>0</b>	[7:4], [31:12]	r	<b>Reserved</b> Read always returns 0

**CC4yECRD0**

Through this register it is possible to read back the FIFO structure of the capture function that is linked with the capture trigger 0. The read back is only valid if the **CC4yTC**.ECM = 1<sub>B</sub>.

**CC4yECRD0 (y = 0 - 3)**

**Extended Read Back 0** (01B8<sub>H</sub> + 0100<sub>H</sub> \* y) **Reset Value: 00000000<sub>H</sub>**



Field	Bits	Type	Description
<b>CAPV</b>	[15:0]	rh	<b>Timer Capture Value</b> This field contains the timer captured value
<b>FPCV</b>	[19:16]	rh	<b>Prescaler Capture value</b> This field contains the value of the prescaler clock division associated with the specific CAPV field

**Capture/Compare Unit 4 (CCU4)**

Field	Bits	Type	Description
<b>SPTR</b>	[21:20]	rh	<b>Slice pointer</b> This field indicates the slice index in which the value was captured. 00 <sub>B</sub> CC40 01 <sub>B</sub> CC41 10 <sub>B</sub> CC42 11 <sub>B</sub> CC43
<b>VPTR</b>	[23:22]	rh	<b>Capture register pointer</b> This field indicates the capture register index in which the value was captured. 00 <sub>B</sub> Capture register 0 01 <sub>B</sub> Capture register 1 10 <sub>B</sub> Capture register 2 11 <sub>B</sub> Capture register 3
<b>FFL</b>	24	rh	<b>Full Flag</b> This bit indicates if the associated capture register contains a new value. 0 <sub>B</sub> No new value was captured into this register 1 <sub>B</sub> A new value has been captured into this register
<b>LCV</b>	25	rh	<b>Lost Capture Value</b> This field indicates if between two reads of the ECRD0 a capture trigger occurred while the FIFO structure was full. If a capture trigger occurred between two reads than a capture value was lost. This field is automatically cleared by the HW whenever a read to the ECRD occurs. 0 <sub>B</sub> No capture was lost 1 <sub>B</sub> A capture was lost
<b>0</b>	[31:26]	r	<b>Reserved</b> Read always returns 0

### CC4yECRD1

Through this register it is possible to read back the FIFO structure of the capture function that is linked with the capture trigger 1. The read back is only valid if the **CC4yTC**.ECM = 1<sub>B</sub>.

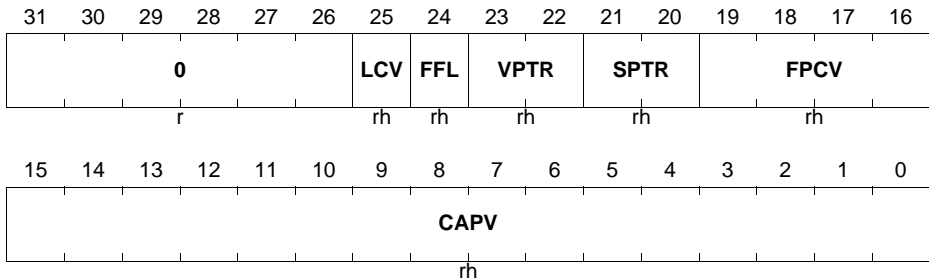
**Capture/Compare Unit 4 (CCU4)**

**CC4yECRD1 (y = 0 - 3)**

**Extended Read Back 1**

**(01BC<sub>H</sub> + 0100<sub>H</sub> \* y)**

**Reset Value: 00000000<sub>H</sub>**



Field	Bits	Type	Description
<b>CAPV</b>	[15:0]	rh	<b>Timer Capture Value</b> This field contains the timer captured value
<b>FPCV</b>	[19:16]	rh	<b>Prescaler Capture value</b> This field contains the value of the prescaler clock division associated with the specific CAPV field
<b>SPTR</b>	[21:20]	rh	<b>Slice pointer</b> This field indicates the slice index in which the value was captured. 00 <sub>B</sub> CC40 01 <sub>B</sub> CC41 10 <sub>B</sub> CC42 11 <sub>B</sub> CC43
<b>VPTR</b>	[23:22]	rh	<b>Capture register pointer</b> This field indicates the capture register index in which the value was captured. 00 <sub>B</sub> Capture register 0 01 <sub>B</sub> Capture register 1 10 <sub>B</sub> Capture register 2 11 <sub>B</sub> Capture register 3
<b>FFL</b>	24	rh	<b>Full Flag</b> This bit indicates if the associated capture register contains a new value. 0 <sub>B</sub> No new value was captured into this register 1 <sub>B</sub> A new value has been captured into this register



**Capture/Compare Unit 4 (CCU4)**

Field	Bits	Type	Description
<b>LCV</b>	25	rh	<b>Lost Capture Value</b> This field indicates if between two reads of the ECRD0 a capture trigger occurred while the FIFO structure was full. If a capture trigger occurred between two reads than a capture value was lost. This field is automatically cleared by the HW whenever a read to the ECRD occurs. 0 <sub>B</sub> No capture was lost 1 <sub>B</sub> A capture was lost
<b>0</b>	[31:26]	r	<b>Reserved</b> Read always returns 0

## 19.8 Interconnects

The tables that refer to the “global pins” are the ones that contain the inputs/outputs of each module that are common to all slices.

The GPIO connections are available at the Ports chapter.

### 19.8.1 CCU40 pins

**Table 19-13 CCU40 Pin Connections**

Global Inputs/Outputs	I/O	Connected To	Description
CCU40.MCLK	I	PCLK	Kernel clock
CCU40.CLKA	I	not connected	another count source for the prescaler
CCU40.CLKB	I	ERU0.IOUT0	another count source for the prescaler
CCU40.CLKC	I	ERU0.IOUT1	another count source for the prescaler
CCU40.MCSS	I	reserved	Multi pattern sync with shadow transfer trigger
CCU40.SR0	O	NVIC; ERU0.OGU01;	Service request line
CCU40.SR1	O	NVIC; ERU0.OGU11;	Service request line

**Capture/Compare Unit 4 (CCU4)**
**Table 19-13 CCU40 Pin Connections (cont'd)**

<b>Global Inputs/Outputs</b>	<b>I/O</b>	<b>Connected To</b>	<b>Description</b>
CCU40.SR2	O	NVIC; VADC0.BGREQTRA; VADC0.G0REQTRA; VADC0.G1REQTRA; ERU0.OGU21;	Service request line
CCU40.SR3	O	NVIC; VADC0.BGREQTRB; VADC0.G0REQTRB; VADC0.G1REQTRB; ERU0.OGU31;	Service request line

**Table 19-14 CCU40 - CC40 Pin Connections**

<b>Input/Output</b>	<b>I/O</b>	<b>Connected To</b>	<b>Description</b>
CCU40.IN0A	I	P0.12	General purpose function
CCU40.IN0B	I	P0.6	General purpose function
CCU40.IN0C	I	P0.0	General purpose function
CCU40.IN0D	I	ERU0.PDOUT1	General purpose function
CCU40.IN0E	I	reserved	General purpose function
CCU40.IN0F	I	reserved	General purpose function
CCU40.IN0G	I	reserved	General purpose function
CCU40.IN0H	I	reserved	General purpose function
CCU40.IN0I	I	SCU.GSC40	General purpose function
CCU40.IN0J	I	ERU0.PDOUT0	General purpose function
CCU40.IN0K	I	ERU0.IOOUT0	General purpose function
CCU40.IN0L	I	USIC0_CH0.DX2INS	General purpose function
CCU40.IN0M	I	CCU40.GP10	General purpose function
CCU40.IN0N	I	CCU40.ST1	General purpose function
CCU40.IN0O	I	CCU40.ST2	General purpose function
CCU40.IN0P	I	CCU40.ST3	General purpose function
CCU40.MCI0	I	BCCU0.OUT2	Multi Channel pattern input

**Capture/Compare Unit 4 (CCU4)**

**Table 19-14 CCU40 - CC40 Pin Connections (cont'd)**

<b>Input/Output</b>	<b>I/O</b>	<b>Connected To</b>	<b>Description</b>
CCU40.OUT0	O	P0.0; P0.5; P0.6; P1.0; P2.0; P2.0.HW1 direction control	Slice compare output
CCU40.GP00	O	CCU40.IN3M	Selected signal for event 0
CCU40.GP01	O	not connected	Selected signal for event 1
CCU40.GP02	O	reserved	Selected signal for event 2
CCU40.ST0	O	CCU40.IN1N; CCU40.IN2N; CCU40.IN3N; VADC0.BGREQGTD; VADC0.G0REQGTD; VADC0.G1REQGTD;	Slice status bit
CCU40.PS0	O	not connected	Multi channel pattern sync trigger: PM when counting UP (edge aligned) or OM when counting DOWN (center aligned)

**Table 19-15 CCU40 - CC41 Pin Connections**

<b>Input/Output</b>	<b>I/O</b>	<b>Connected To</b>	<b>Description</b>
CCU40.IN1A	I	P0.12	General purpose function
CCU40.IN1B	I	P0.7	General purpose function
CCU40.IN1C	I	P0.1	General purpose function
CCU40.IN1D	I	ERU0.PDOUT0	General purpose function
CCU40.IN1E	I	reserved	General purpose function
CCU40.IN1F	I	reserved	General purpose function
CCU40.IN1G	I	reserved	General purpose function
CCU40.IN1H	I	reserved	General purpose function
CCU40.IN1I	I	SCU.GSC40	General purpose function
CCU40.IN1J	I	ERU0.PDOUT1	General purpose function
CCU40.IN1K	I	ERU0.IOOUT1	General purpose function

**Capture/Compare Unit 4 (CCU4)**

**Table 19-15 CCU40 - CC41 Pin Connections (cont'd)**

<b>Input/Output</b>	<b>I/O</b>	<b>Connected To</b>	<b>Description</b>
CCU40.IN1L	I	USIC0_CH1.DX2INS	General purpose function
CCU40.IN1M	I	CCU40.GP20	General purpose function
CCU40.IN1N	I	CCU40.ST0	General purpose function
CCU40.IN1O	I	CCU40.ST2	General purpose function
CCU40.IN1P	I	CCU40.ST3	General purpose function
CCU40.MC11	I	BCCU0.OUT3	Multi Channel pattern input
CCU40.OUT1	O	P0.1; P0.4; P0.7; P1.1; P2.1; P2.1.HW1 direction control	Slice compare output
CCU40.GP10	O	CCU40.IN0M	Selected signal for event 0
CCU40.GP11	O	not connected	Selected signal for event 1
CCU40.GP12	O	reserved	Selected signal for event 2
CCU40.ST1	O	CCU40.IN0N; CCU40.IN2O; CCU40.IN3O; VADC0.BGREQGTC; VADC0.G0REQGTC; VADC0.G1REQGTC;	Slice status bit
CCU40.PS1	O	reserved	Multi channel pattern sync trigger: PM when counting UP (edge aligned) or OM when counting DOWN (center aligned)

**Table 19-16 CCU40 - CC42 Pin Connections**

<b>Input/Output</b>	<b>I/O</b>	<b>Connected To</b>	<b>Description</b>
CCU40.IN2A	I	P0.12	General purpose function
CCU40.IN2B	I	P0.8	General purpose function
CCU40.IN2C	I	P0.2	General purpose function
CCU40.IN2D	I	ERU0.PDOOUT3	General purpose function
CCU40.IN2E	I	reserved	General purpose function

**Capture/Compare Unit 4 (CCU4)**

**Table 19-16 CCU40 - CC42 Pin Connections (cont'd)**

<b>Input/Output</b>	<b>I/O</b>	<b>Connected To</b>	<b>Description</b>
CCU40.IN2F	I	reserved	General purpose function
CCU40.IN2G	I	reserved	General purpose function
CCU40.IN2H	I	reserved	General purpose function
CCU40.IN2I	I	SCU.GSC40	General purpose function
CCU40.IN2J	I	ERU0.PDOU2	General purpose function
CCU40.IN2K	I	ERU0.IOU2	General purpose function
CCU40.IN2L	I	LEDS0.SR0	General purpose function
CCU40.IN2M	I	CCU40.GP30	General purpose function
CCU40.IN2N	I	CCU40.ST0	General purpose function
CCU40.IN2O	I	CCU40.ST1	General purpose function
CCU40.IN2P	I	CCU40.ST3	General purpose function
CCU40.MCI2	I	BCCU0.OUT4	Multi Channel pattern input
CCU40.OUT2	O	P0.2; P0.8; P1.2; P2.10; P2.8.HW1 pull control P2.9.HW1 pull control P2.10.HW1 direction control	Slice compare output
CCU40.GP20	O	CCU40.IN1M	Selected signal for event 0
CCU40.GP21	O	not connected	Selected signal for event 1
CCU40.GP22	O	reserved	Selected signal for event 2
CCU40.ST2	O	CCU40.IN0O; CCU40.IN1O; CCU40.IN3P; VADC0.BGREQG7B; VADC0.G0REQG7B; VADC0.G1REQG7B;	Slice status bit
CCU40.PS0	O	not connected	Multi channel pattern sync trigger: PM when counting UP (edge aligned) or OM when counting DOWN (center aligned)

**Table 19-17 CCU40 - CC43 Pin Connections**

<b>Input/Output</b>	<b>I/O</b>	<b>Connected To</b>	<b>Description</b>
CCU40.IN3A	I	P0.12	General purpose function
CCU40.IN3B	I	P0.9	General purpose function
CCU40.IN3C	I	P0.3	General purpose function
CCU40.IN3D	I	ERU0.PDOUT2	General purpose function
CCU40.IN3E	I	reserved	General purpose function
CCU40.IN3F	I	reserved	General purpose function
CCU40.IN3G	I	VADC0.G0ARBCNT	General purpose function
CCU40.IN3H	I	reserved	General purpose function
CCU40.IN3I	I	SCU.GSC40	General purpose function
CCU40.IN3J	I	ERU0.PDOUT3	General purpose function
CCU40.IN3K	I	ERU0.IOOUT3	General purpose function
CCU40.IN3L	I	LEDTS1.SR0	General purpose function
CCU40.IN3M	I	CCU40.GP00	General purpose function
CCU40.IN3N	I	CCU40.ST0	General purpose function
CCU40.IN3O	I	CCU40.ST1	General purpose function
CCU40.IN3P	I	CCU40.ST2	General purpose function
CCU40.MCI3	I	BCCU0.OUT5	Multi Channel pattern input
CCU40.OUT3	O	P0.3; P0.9; P1.3; P2.11; P2.2.HW1 pull control P2.6.HW1 pull control P2.7.HW1 pull control P2.11.HW1 direction control	Slice compare output
CCU40.GP30	O	CCU40.IN2M	Selected signal for event 0
CCU40.GP31	O	not connected	Selected signal for event 1
CCU40.GP32	O	reserved	Selected signal for event 2

**Capture/Compare Unit 4 (CCU4)**

**Table 19-17 CCU40 - CC43 Pin Connections (cont'd)**

<b>Input/Output</b>	<b>I/O</b>	<b>Connected To</b>	<b>Description</b>
CCU40.ST3	O	CCU40.IN0P; CCU40.IN1P; CCU40.IN2P; VADC0.BGREQGTA; VADC0.G0REQGTA; VADC0.G1REQGTA;	Slice status bit
CCU40.PS3	O	not connected	Multi channel pattern sync trigger: PM when counting UP (edge aligned) or OM when counting DOWN (center aligned)

## **20 Brightness and Color Control Unit (BCCU)**

The BCCU is a dimming control peripheral for LED lighting applications that is capable of controlling multiple LED channels. A one-bit sigma-delta bit stream is provided for every channel that determines the brightness. The brightness can be changed gradually along an exponential curve to appear natural to the human eye by using dedicated dimming engines. The module supports color control by adjusting the relative intensity of selected channels using a linear walk scheme for smooth color changes, and it also supports high-power multi-channel LED lamps by optionally “packing” the bitstream to provide a defined ON-time at the output.

### **20.1 Overview**

The BCCU in XMC1200 contains 3 identical dimming engines and 9 identical channels. Each channel can generate a one-bit flexible sigma-delta bit stream with a user-adjustable 12-bit average value. This average value can be provided manually or by any of the exponential dimming engines. The bit stream is generated by a 12-bit sigma-delta modulator, and an optional packer which decreases the average rate of output switching by enforcing a defined on-time. Although the primary target application is multi-channel LED dimming with special support for color control, the module can also be used as a multi-channel digital-analog converter with low-pass filters on the outputs.

#### **20.1.1 Features**

The BCCU provides the following functionality:

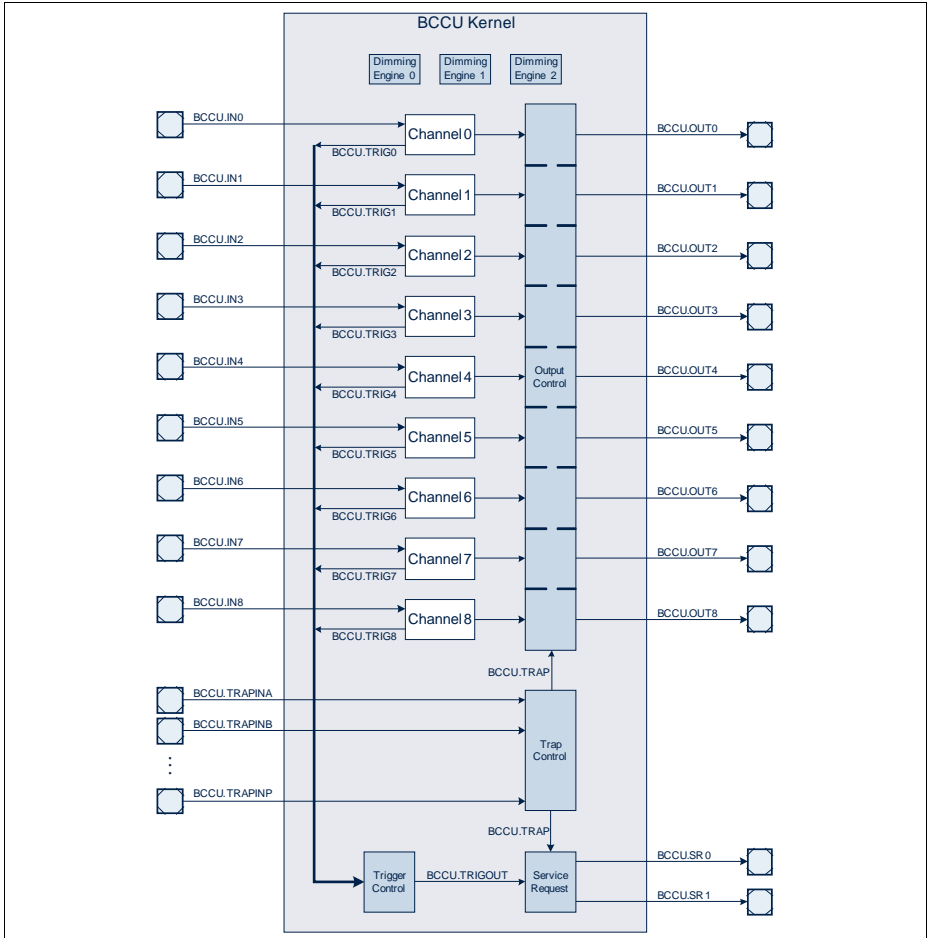
- 3 independent dimming engines
- 12-bit dimming levels
- Dimming along an exponential curve with adjustable dimming time
- 9 independent channels generating a 1-bit on-off signal each
- 12-bit channel intensities to define color
- Channels and dimming engines can be freely interconnected
- One input multiplier and one 12-bit sigma-delta modulator in every channel
- One bit-packer in every channel to decrease the average rate of output switching
- TRAP function
- Two ADC triggering modes

### **20.2 Functional Description**

Each channel can operate independently from the others and can be freely interconnected with any one of the dimming engines. Triggering and TRAP control are globally handled for all channels.



**Brightness and Color Control Unit (BCCU)**



**Figure 20-1 BCCU Kernel Block Diagram**

Every dimming engine generates a 12-bit dimming level which can be routed to the input of any channel. Optionally a manually controllable 12-bit "Global Dimming Level" (BCCU\_GLOBDIM.GLOBDIM) is also routable to the channels instead.

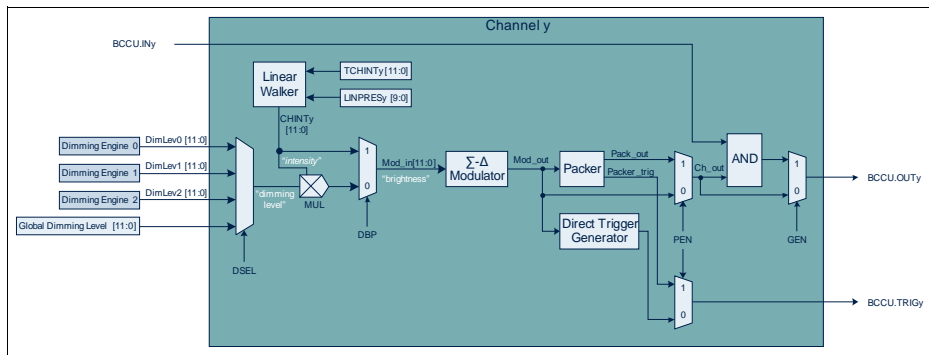
**20.2.1 Channel Structure**

Every active channel has a 12-bit intensity level (BCCU\_INTY ( $y=0-8$ ).CHINT). The brightness level (same as the average level of the output bit stream) is the product of the dimming level and the intensity level.

## Brightness and Color Control Unit (BCCU)

Generally in multi-channel solutions, the intensity level is expected to determine the color and the dimming level is expected to be used for changes in overall brightness. E.g. in case of an RGB LED, 3 channels can be used; the individual intensity levels determine the color and a common dimming level (e.g. coming from one of the dimming engines) determines the overall brightness.

The 12-bit brightness level is the input to the sigma-delta modulator where it is converted into a fast changing 1-bit signal with the same average value. The average rate of switching of this signal is optionally decreased by a packer which generates a signal with fixed on-time or fixed off-time. This signal still has the same average value.



**Figure 20-2 Channel Block Diagram**

BCCU.INy is an asynchronous gating signal which can be used if BCCU\_CHCONFIGy (y=0-8).GEN is set. The gating connection is made of combinatorial logic only to enable fast control schemes, such as peak-current control.

If the packer is disabled, the trigger signal for the ADC is directly generated from the output of the sigma-delta modulator in the Trigger Generator block. The trigger pulse is generated on rising edge (transition from passive to active state) if BCCU\_CHCONFIGy (y=0-8).TRED is 0 and on falling edge if BCCU\_CHCONFIGy (y=0-8).TRED is 1. If BCCU\_CHCONFIGy (y=0-8).ENFT is 1, forced trigger generation is enabled. A forced trigger is generated if the output signal (Mod\_out) hasn't changed state for a long time (256 bit times).

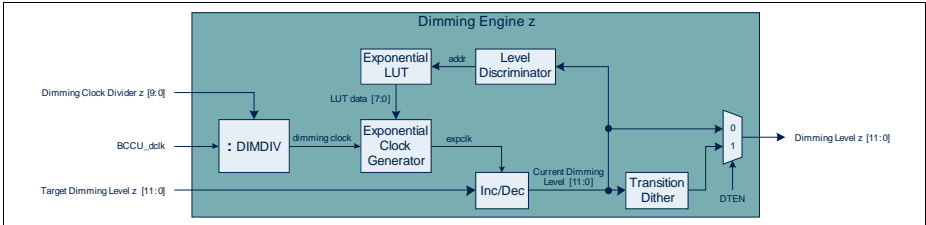
### 20.2.2 Exponential Dimming

The BCCU contains 3 dimming engines that are routable to all 9 channels. The dimming engine is capable of gradually changing the brightness level in order for the human eye to comfortably adapt to changes in light intensity. Since the human eye perceives light with logarithmic sensitivity, the gradual change of brightness is performed along a pseudo-exponential curve. The user has to set the target dimming level (BCCU\_DLSz (z=0-2).TDLEV) and initiate the shadow transfer (by setting BCCU\_DESTRCON.DEzS).

**Brightness and Color Control Unit (BCCU)**

The dimming level (BCCU\_ **DLz (z=0-2)**.DIMLEV) is a time-varying signal. After shadow transfer, it will gradually reach the target dimming level along the pseudo-exponential curve. When the target is reached, BCCU\_ **DESTRCON**.DEzS is cleared by hardware.

The dimming process can be aborted anytime by setting BCCU\_ **DESTRCON**.DEzA, which is recommended before starting a new dimming process if the actual one hasn't finished yet. This will also clear BCCU\_ **DESTRCON**.DEzS.



**Figure 20-3 Dimming Engine Block Diagram**

Above the level of 16, the ideal exponential dimming curve is described as:

$$\text{DimmingLevel} = 2^{\frac{\text{DimmingClocks} + 4096}{2048}} \quad (20.1)$$

The actual dimming curve approximates the ideal by combining straight lines forming a piecewise pseudo-exponential curve.

The module provides two curves to choose from, a coarse curve and a fine curve. The desired curve can be selected by BCCU\_ **DTTz (z=0-2)**.CSEL. The difference is in the number of straight lines used to approximate the ideal exponential curve.

As the dimming level increases along the coarse curve, the slope of the linear pieces doubles every time it passes one of the thresholds of 16, 32, 64, 128, 256, 512, 1024 or 2048.

**Table 20-1 Coarse Piece-Wise Pseudo-Exponential Curve**

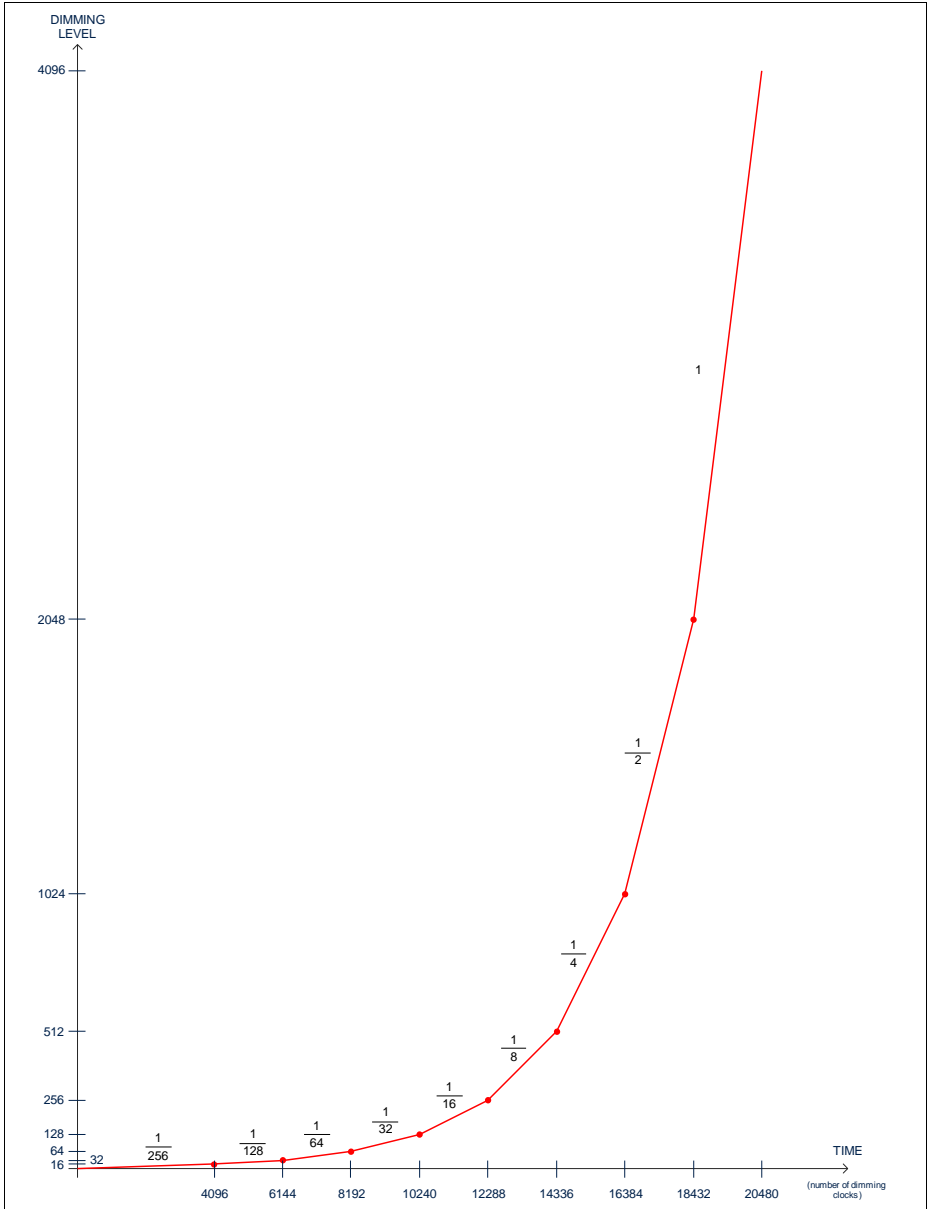
Upper dimming threshold	Slope of the linear piece	Number of dimming clocks along the line
16	1/256	4096
32	1/128	2048
64	1/64	2048
128	1/32	2048
256	1/16	2048
512	1/8	2048

**Brightness and Color Control Unit (BCCU)**

**Table 20-1 Coarse Piece-Wise Pseudo-Exponential Curve**

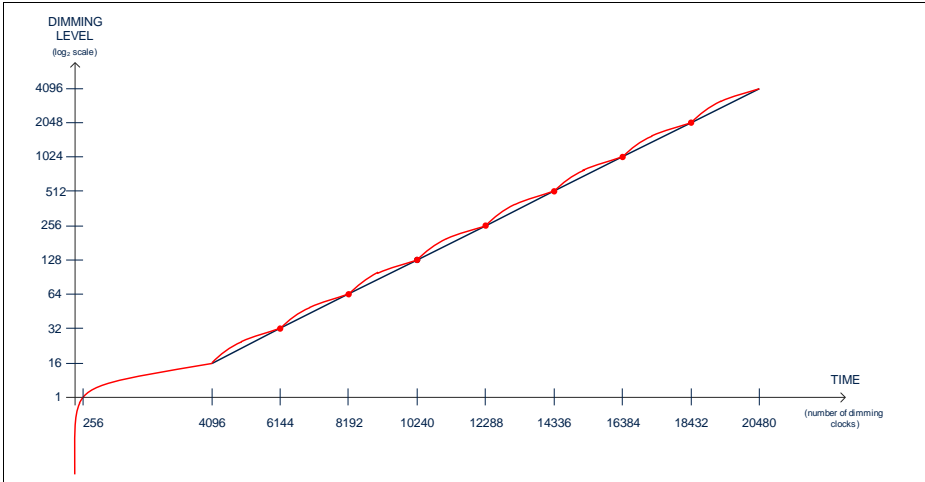
<b>Upper dimming threshold</b>	<b>Slope of the linear piece</b>	<b>Number of dimming clocks along the line</b>
1024	1/4	2048
2048	1/2	2048
4095	1	2047

**Brightness and Color Control Unit (BCCU)**



**Figure 20-4 Coarse Piecewise pseudo-exponential curve**

**Brightness and Color Control Unit (BCCU)**



**Figure 20-5 Coarse Piecewise pseudo-exponential curve with the dimming level on a logarithmic scale as the human eye sees it (real and ideal)**

This piecewise pseudo-exponential curve is quantized into 4095 steps. When BCCU\_DESTRCON.DEzS is set, the first step is immediately taken towards the target and at every dimming level, the dimming engine waits for a certain amount of dimming clocks (“waiting time”) before taking the next step. This waiting time determines the slope of the linear piece. Once the target level has been reached and the appropriate amount of clocks have elapsed, BCCU\_DESTRCON.DEzS is cleared by hardware signalling the end of the dimming process. Dimming up from 0 to 4095 takes 20479 dimming clocks (not counting synchronization and bus communication delays).

**Table 20-2 Quantized CoarsePiece-Wise Pseudo-Exponential Curve**

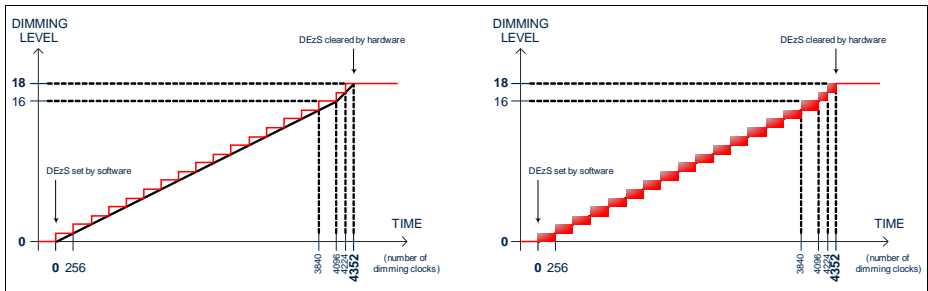
Dimming Levels	Clocks before the next step (“waiting time”)	Slope of the linear piece
0..16	256	1/256
17..32	128	1/128
33..64	64	1/64
65..128	32	1/32
129..256	16	1/16
257..512	8	1/8
513..1024	4	1/4

**Brightness and Color Control Unit (BCCU)**

**Table 20-2 Quantized CoarsePiece-Wise Pseudo-Exponential Curve**

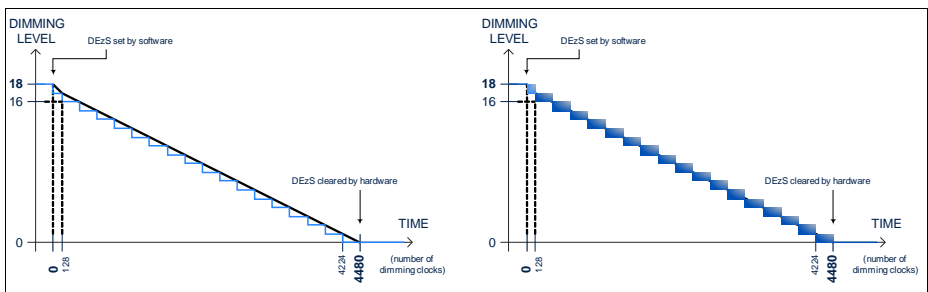
Dimming Levels	Clocks before the next step ("waiting time")	Slope of the linear piece
1025..2048	2	1/2
2049..	1	1

For example dimming from 0 to 18 along the coarse curve takes 4352 clocks ( $16 \times 256$  clocks +  $2 \times 128$  clocks) when measured as the time between setting and clearing BCCU\_DESTRCON.DEzS (ignoring delays).



**Figure 20-6 Dimming from 0 to 18 along the coarse curve without and with dither enabled**

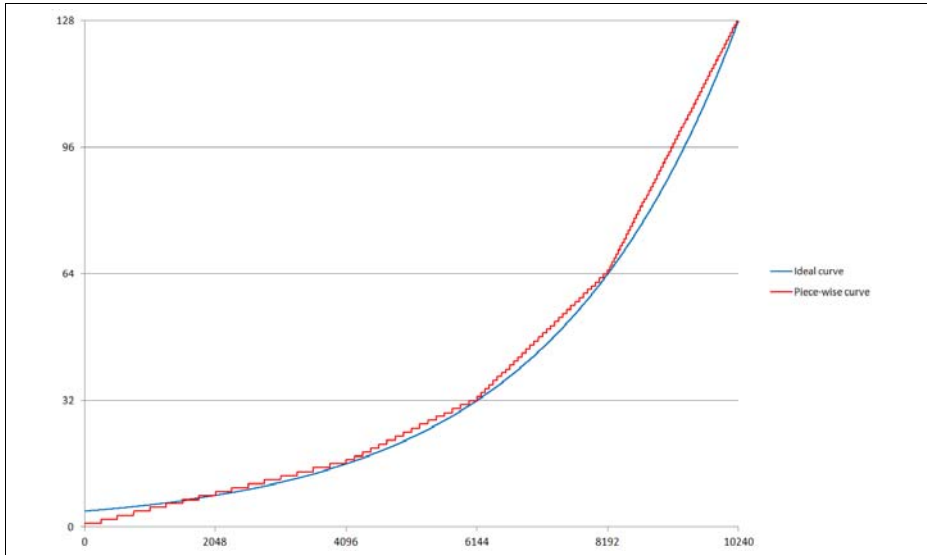
Exponential clock generation is the same regardless of the direction of the dimming so the waiting time before the next step is the same at a given dimming level whether the next step is an increment or a decrement. Because of this, dimming down takes longer than dimming up with the same settings. The extra time is equivalent to the waiting time of the target level minus the waiting time of the starting level. Dimming down from 4095 to 0 takes 20734 clocks ( $20479 + 256 - 1$ ). Dimming down from 18 to 0 along the coarse curve takes 4480 clocks ( $4352 + 256 - 128$ ).



**Figure 20-7 Dimming from 18 to 0 along the coarse curve without and with dither**

**Brightness and Color Control Unit (BCCU)**

**enabled**



**Figure 20-8 Lower section of the coarse curve (real and ideal)**

The fine curve is similar to the coarse one but it has more pieces and different line slopes.

**Table 20-3 Fine Piece-Wise Pseudo-Exponential Curve**

Upper dimming threshold	Slope of the linear piece	Number of dimming clocks along the line
16	1/256	4096
18	1/196	392
25	1/132	924
34	1/102	918
41	1/81	567
48	1/64	448
69	1/51	1071
79	1/40	400
107	1/32	896
130	1/25	575



**Brightness and Color Control Unit (BCCU)**

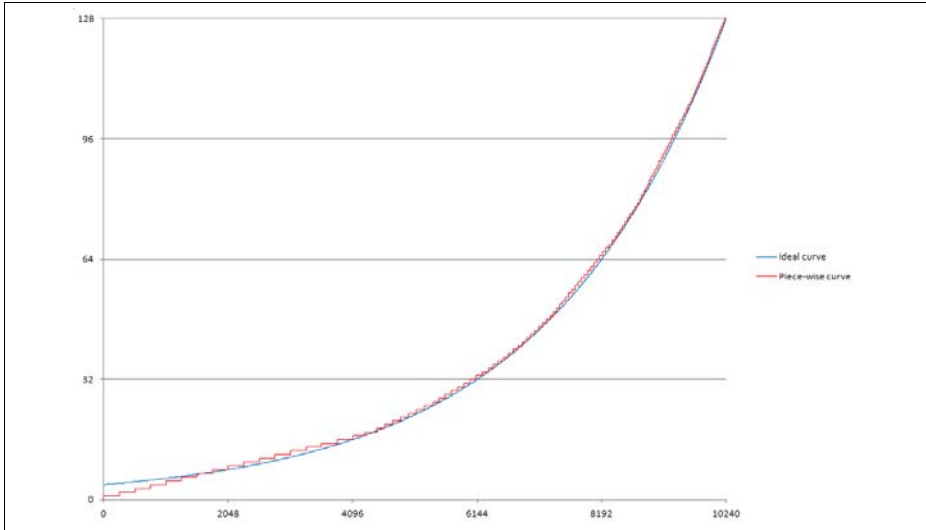
**Table 20-3 Fine Piece-Wise Pseudo-Exponential Curve**

Upper dimming threshold	Slope of the linear piece	Number of dimming clocks along the line
167	1/20	740
203	1/16	576
253	1/13	650
343	1/10	900
512	1/7	1183
1024	1/4	2048
2048	1/2	2048
4095	1	2047

**Table 20-4 Fine Piece-Wise Pseudo-Exponential Curve**

Dimming Levels	Clocks before the next step ("waiting time")	Slope of the linear piece
0..16	256	1/256
17..18	196	1/196
19..25	132	1/132
26..34	102	1/102
35..41	81	1/81
42..48	64	1/64
49..69	51	1/51
70..79	40	1/40
80..107	32	1/32
108..130	25	1/25
131..167	20	1/20
168..203	16	1/16
204..253	13	1/13
254..343	10	1/10
334..512	7	1/7
513..1024	4	1/4
1025..2048	2	1/2
2049..4095	1	1

**Brightness and Color Control Unit (BCCU)**



**Figure 20-9 Lower section of the fine curve (real and ideal)**

Dimming along the entire dimming curve takes 20479 dimming clocks when dimming up and 20734 clocks when dimming down. The fade time from 0 to 4095 (0% to 100%) is adjustable through the "dimming clock divider" bitfield (BCCU\_DTTz (z=0-2).DIMDIV):

$$\text{FadeTime}_{0-100} = \frac{20479}{\left(\frac{f_{\text{BCCUclk}}}{\text{DCLKPS} \times \text{DIMDIV}}\right)} = \frac{20479}{\left(\frac{f_{\text{BCCUclk}}}{\text{DIMDIV}}\right)} \quad (20.2)$$

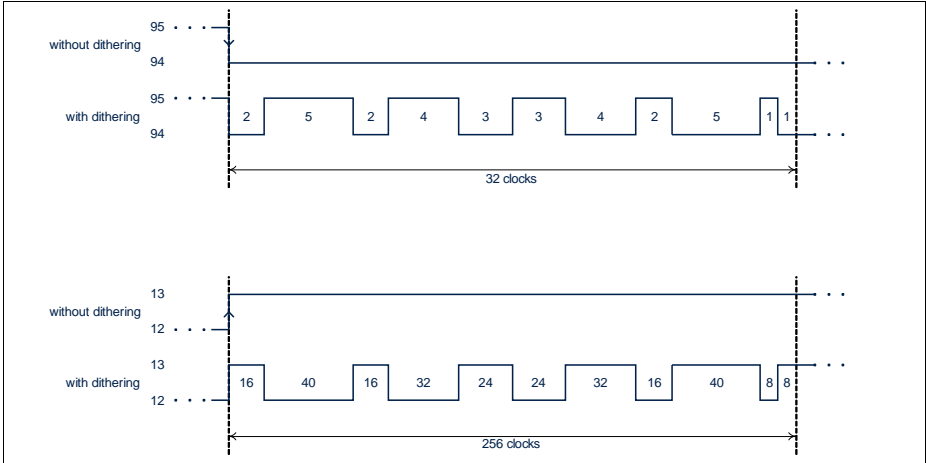
$$\text{FadeTime}_{100-0} = \frac{20734}{\left(\frac{f_{\text{BCCUclk}}}{\text{DCLKPS} \times \text{DIMDIV}}\right)} = \frac{20734}{\left(\frac{f_{\text{BCCUclk}}}{\text{DIMDIV}}\right)} \quad (20.3)$$

If BCCU\_DTTz (z=0-2).DIMDIV is 0, the dimming level will instantly be the same as the target dimming level on shadow transfer, which means that the dimming engine is effectively bypassed.

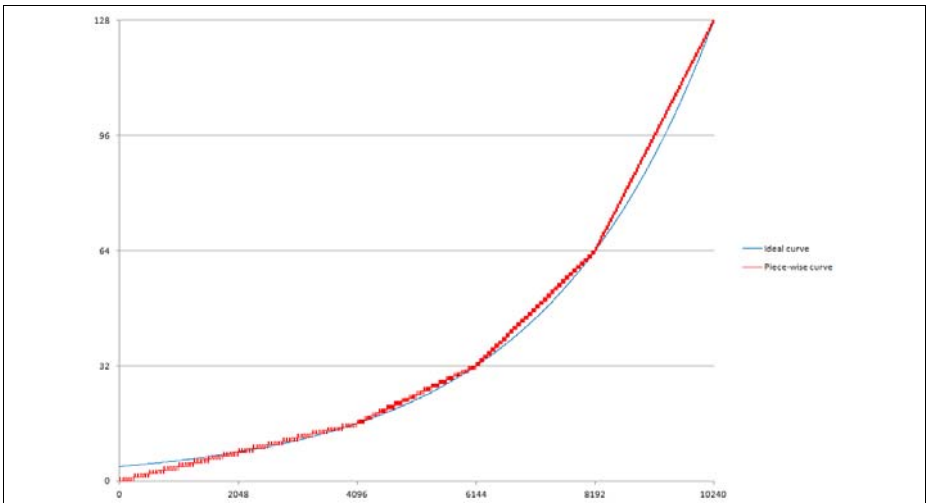
At dimming levels below 128, where the human eye is potentially very sensitive to changes in brightness, the dimming steps can be dithered to avoid visible discrete steps in brightness. This function can be enabled by setting BCCU\_DTTz (z=0-2).DTEN. Only the coarse curve can be used with dithering. Every time the dimming level (BCCU\_DLz (z=0-2).DLEV) is supposed to increase or decrease by 1 ("dimming step"), a dither pattern is superimposed on it to make the transition appear smoother to the human eye. The pattern lasts 256 dimming clocks between dimming levels of 0 and 15, 128 dimming

**Brightness and Color Control Unit (BCCU)**

clocks between 16 and 31, 64 dimming clocks between 32 and 63 and 32 dimming clocks between 64 and 127.



**Figure 20-10 Dithering examples**



**Figure 20-11 Lower section of the coarse curve with dithering enabled (real and ideal)**

**Brightness and Color Control Unit (BCCU)**

Dithering the transition from dimming level of 0 to 1 may cause visible blinking. This can be avoided by enabling the flicker watchdog in the affected channels. The flicker watchdog can be enabled by setting bit **CHCONFIGy (y=0-8).WEN**.

**20.2.3 Linear Color Walk**

The intensity level (**BCCU\_INTy (y=0-8).CHINT**) can be changed using a linear walk. The transition time, aka linear walk time, is user adjustable by programming the (**BCCU\_CHCONFIGy (y=0-8).LINPRES**) bitfield. Reaching the target intensity level (**BCCU\_INTSy (y=0-8).TCHINT**) after shadow transfer (setting **BCCU\_CHSTRCON.CHyS**) will take the selected transition time which can be calculated by the following formula:

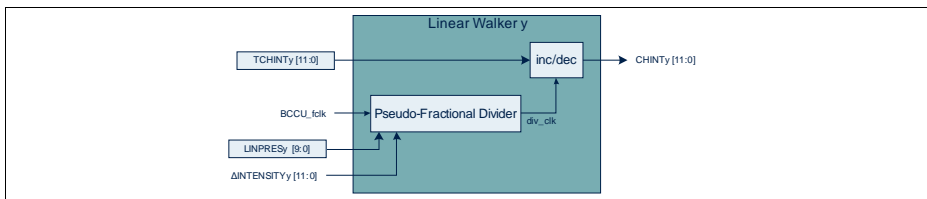
$$\text{LINEARWALKTIME} = \frac{\text{LINPRES} \times 2^{13}}{f_{\text{BCCUclk}}} \quad (20.4)$$

Once the linear walk is done, **BCCU\_CHSTRCON.CHyS** is cleared by hardware. Setting **BCCU\_CHSTRCON.CHyA** will abort the linear walk and will clear **BCCU\_CHSTRCON.CHyS**.

**BCCU\_INTSy (y=0-8).TCHINT** cannot be written while the linear walk is ongoing (**BCCU\_CHSTRCON.CHyS** is set). During this time, write accesses are ignored. The user either has to first wait until the walk is finished or has to manually abort the walk by setting **BCCU\_CHSTRCON.CHyA**.

If **BCCU\_CHCONFIGy (y=0-8).LINPRES** is 0, the intensity level will be the same as the target intensity level on shadow transfer, which means that the linear walker is effectively bypassed.

Smooth color transition can be achieved by setting the same transition time for the respective channels and initiating shadow transfer at the same time. The delta intensity value is calculated as the difference between the channel intensity and the target channel intensity at the time of the channel shadow transfer.



**Figure 20-12 Linear Walker Block Diagram**

**Brightness and Color Control Unit (BCCU)**

**20.2.4 Sigma-Delta Modulator**

The sigma-delta modulator oversamples the slowly changing 12-bit brightness signal and changes it into a high bitrate single-bit signal. The average analog value of the single-bit signal is directly proportional to the 12-bit brightness value. Low-pass filtering is performed by the human eye.

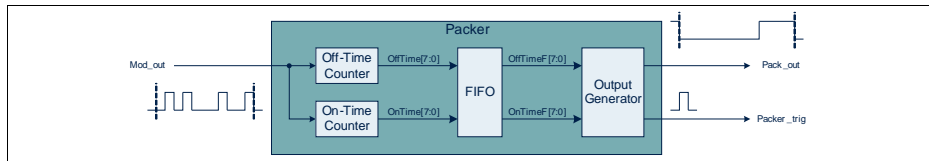
The modulator contains a flicker watchdog which, if enabled, limits the number of consecutive off-bits (0) at the output to avoid visible flickering. The maximum number of off-bits allowed is determined by BCCU\_GLOBCON.WDMBN. If the number of consecutive off-bits reaches this threshold, an on-bit (1) is inserted into the bitstream.

The minimum frequency of on bits is defined by the following formula:

$$f_{\min} = \frac{1}{\text{WDMBN}} \times f_{\text{BCCUclk}} \quad (20.5)$$

**20.2.5 Packer**

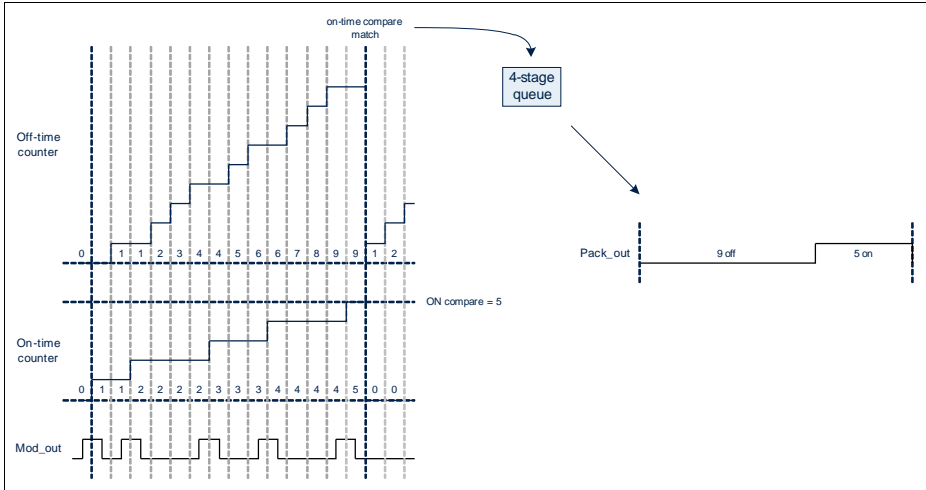
The main purpose of the packer is to decrease the average rate of switching of the output signal to decrease the load on external switching circuits and improve EMC behavior. The packer contains two 8-bit counters, a 4-stage FIFO and an output generator.



**Figure 20-13 Packer Block Diagram**

The on-time counter (BCU\_PKCNTy (y=0-8).ONCNTVAL) counts the on-bits of the input bit stream (Mod\_out) and the off-time counter (BCU\_PKCNTy (y=0-8).OFFCNTVAL) counts the off bits. If the off-time counter or the on-time counter reaches the user adjustable compare level (BCCU\_PKCMpy (y=0-8).ONCMP or BCCU\_PKCMpy (y=0-8).OFFCMP), both timers reset and start counting again. Before the timers reset, their counts (BCCU\_PKCNTy (y=0-8).ONCNTVAL and BCCU\_PKCNTy (y=0-8).OFFCNTVAL) are loaded into a queue (FIFO). The counts are taken one by one from the queue in an alternating manner by the output generator and a packed off-on signal packet is generated (Pack\_out). If the queue is empty, the output generator generates an off-bit (0) for one bit clock before checking the FIFO again. On microcontroller reset or if the channel has been disabled and enabled again, all queue stages are empty. When the packer becomes enabled (BCCU\_CHCONFy (y=0-8).PEN), the output generator only starts taking the values from the queue once enough stages are filled (determined by BCCU\_CHCONFy (y=0-8).PKTH). Until that, only off-bits are generated at the output.

**Brightness and Color Control Unit (BCCU)**



**Figure 20-14 Signal Packing (example)**

BCCU\_PKCNTry ( $y=0-8$ ).ONCNTVAL and BCCU\_PKCNTry ( $y=0-8$ ).OFFCNTVAL can be manually updated while the channel is not enabled (BCCU\_CHEN.ECHy is 0). By putting a starting value other than zero in the counters, the user can introduce a “phase shift” between different channels to avoid identical behavior.

The packed signal has fixed on-time if the brightness level is high enough so that the on-time compare value is reached. Below a certain brightness level, the off-time compare value is reached before the on-time compare value. In this case the packed signal has a fixed off-time. The compare level determines the length of the packed signal packets which can be calculated with the following formulae:

$$\text{PacketTime}_{\min} = \text{ONCMP} \times \frac{1}{f_{\text{BCCUbcIk}}}$$

$$\text{PacketTime}_{\max} = (\text{ONCMP} + \text{OFFCMP}) \times \frac{1}{f_{\text{BCCUbcIk}}} \quad (20.6)$$

### 20.2.6 Global Trigger Control

The BCCU generates two trigger signals to the ADC (BCCU\_TRIGOUT0 and BCCU\_TRIGOUT1) to start conversions in a synchronized manner. In certain use cases, ADC samples are only meaningful if the respective control signal is active (e.g. the respective LED string is on). The output state of the BCCU channels when the last trigger occurred can be observed by checking the "Last Trigger Channel Output Level Register" (BCCU\_LTCHOL). The channels can be individually enabled in the "Channel Enable

---

**Brightness and Color Control Unit (BCCU)**

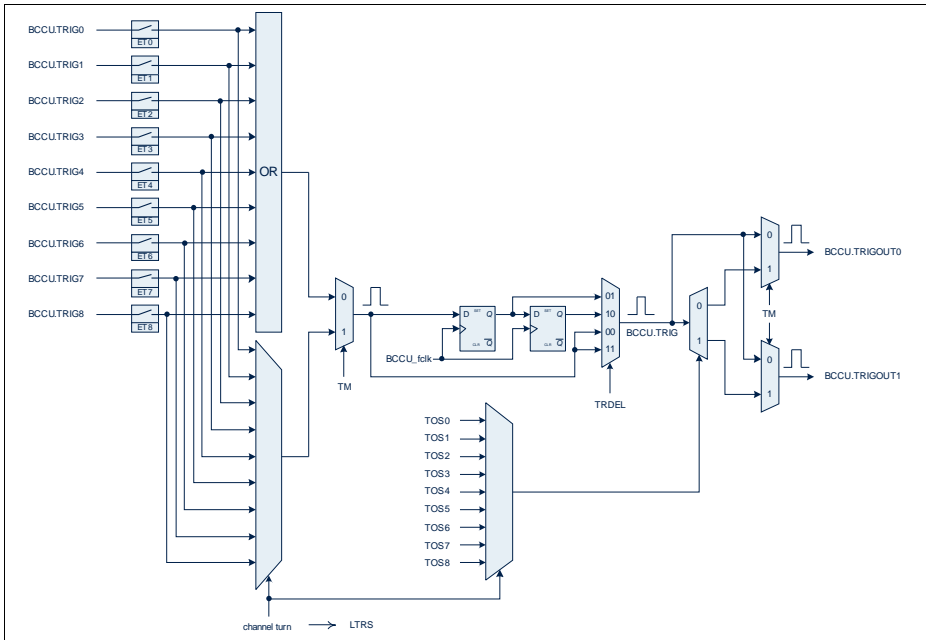
Register" (BCCU\_ **CHEN**.ECHy). Triggering can be individually enabled for every channel in the "Channel Trigger Register" (BCCU\_ **CHTRIG**.ETy). Only enabled channels with enabled triggering participate in the triggering mechanism. Trigger occurs on a passive-to-active or active-to-passive transition of the channel output which can be individually selected for every channel (BCCU\_ **CHCONFIGy** (y=0-8).TRED).

The BCCU offers two trigger modes (BCCU\_ **GLOBCON**.TM). In mode 0, any channel trigger causes a trigger to the ADC on both trigger signals. When that happens, the ADC is expected to sample every channel and the user software has to decide which results are valid based on BCCU\_ **LTCHOL**.

In mode 1, only one channel trigger generates an ADC trigger at a time. The channels take turns in trigger generation in a round robin manner starting from 0 and counting up. The trigger can be generated either on BCCU\_TRIGOUT0 or on BCCU\_TRIGOUT1 which is selectable for each channel individually by BCCU\_ **CHTRIG**.TOSy. When a trigger has been generated, the channel pointer will point to the next participating channel to generate the next trigger. Every trigger will cause only one ADC measurement. Some additional user software may be necessary to control which ADC channel is triggered at a given time. BCCU\_ **GLOBCON**.LTRS shows which BCCU channel generated the last trigger. The channel pointer is reset and will point to channel 0 if all channel trigger enable bits (BCCU\_ **CHTRIG**.ETy) are 0.

The trigger can optionally be delayed by a quarter bit time or half a bit time to avoid sampling during switching noise. This is selectable by the BCCU\_ **GLOBCON**.TRDEL bitfield. This delay is only functional if BCCU\_bclk is generated in normal mode (BCCU\_ **GLOBCLK**.BCS is 0).

**Brightness and Color Control Unit (BCCU)**



**Figure 20-15 BCCU Trigger Generation**

**20.2.7 Trap Control**

The trap functionality allows the BCCU outputs to react to a state of an input pin. This functionality can be used to switch off the connected power devices if the trap input becomes active (i.e. a trap occurs). A trap is a global event but trap functionality can be enabled for every channel individually by setting the BCCU\_ **CHOCON**.CHxTPE bits. If the corresponding bit is not set, the given channel will ignore the trap event.

A trap event occurs if a rising or a falling edge (user selectable via BCCU\_ **GLOBCON**.TRAPED) is detected on the BCCU.TRAPL signal. When a trap occurs, the affected channel outputs immediately<sup>1)</sup> go to their respective passive levels, determined by BCCU\_ **CHOCON**.CHyOP, while the event flag (BCCU\_ **EVFR**.TPF) and the trap state flag (BCCU\_ **EVFR**.TPSF) bits will be set.

BCCU\_ **EVFR**.TPF can be reset by writing 1 to BCCU\_ **EVFCR**.TPFC. This operation has no effect on the channel outputs. BCCU\_ **EVFR**.TPSF can be reset by writing 1 to BCCU\_ **EVFCR**.TPC. This will clear the trap and the channel outputs will go back to their respective output levels based on the channels' conditions. The user can monitor the

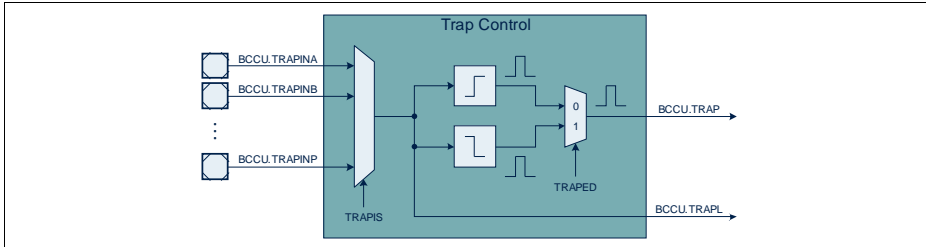
1) After a synchronization delay of 4 BCCU\_clk cycles



**Brightness and Color Control Unit (BCCU)**

level of BCCU.TRAPL via bit BCCU\_EVFR.TPINL and may only want to exit the trap state once the trap signal is inactive.

BCCU\_EVFR.TPSF can also be set by writing 1 to BCCU\_EVFSR.TPS to generate a software trap.



**Figure 20-16 Trap Control**

### 20.3 Power, Reset and Clock

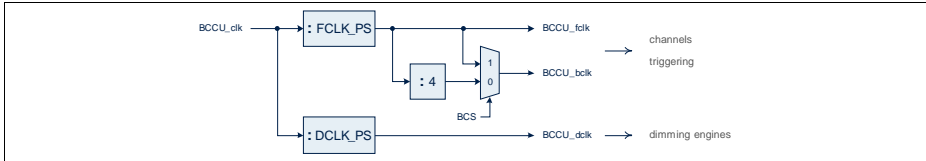
BCCU is located in the core power domain. The module, including all registers other than the bit field BCCU\_GLOBCON.SUSCFG, can be reset to its default state by a system reset. The bit field BCCU\_GLOBCON.SUSCFG is reset to its default value only by a debug reset.

*Note: In XMC1200, as there is no separate debug reset, the bit field BCCU\_GLOBCON.SUSCFG will be reset to its default state by a system reset.*

The BCCU kernel is clocked (BCCU\_clk) and accessible on the peripheral bus frequency (PCLK). Three main clocks are generated for the different blocks in the module:

- BCCU\_bclk (bit clock) is the clock that determines the sampling rate of the sigma-delta converter and the bit time of the signal it generates. Depending on BCCU\_GLOBCLK.BCS, BCCU\_bclk is generated from BCCU\_fclk via a 4 divider or it is the same as BCCU\_fclk.
- BCCU\_fclk (fast clock) is used by the Trigger Control block to generate the trigger delay. It is generated from BCCU\_clk by a prescaler. The frequency can be set by BCCU\_GLOBCLK.FCLK\_PS.
- BCCU\_dclk (dimming engine clock) is the input clock to the dimming engines. It is generated from BCCU\_clk by a prescaler. The frequency can be set by BCCU\_GLOBCLK.DCLK\_PS.

**Brightness and Color Control Unit (BCCU)**



**Figure 20-17 BCCU clocks**

The clock frequencies in normal mode can be calculated with the following formulae:

$$f_{\text{BCCUfclk}} = \frac{1}{\text{FCLKPS}} \times f_{\text{BCCUclk}} \quad (20.7)$$

$$f_{\text{BCCUbclk}} = \frac{1}{\text{FCLKPS} \times 4} \times f_{\text{BCCUclk}} \quad (20.8)$$

$$f_{\text{BCCUdclk}} = \frac{1}{\text{DCLKPS}} \times f_{\text{BCCUclk}} \quad (20.9)$$

The kernel is only in operation in active mode.

## 20.4 Service Request Generation

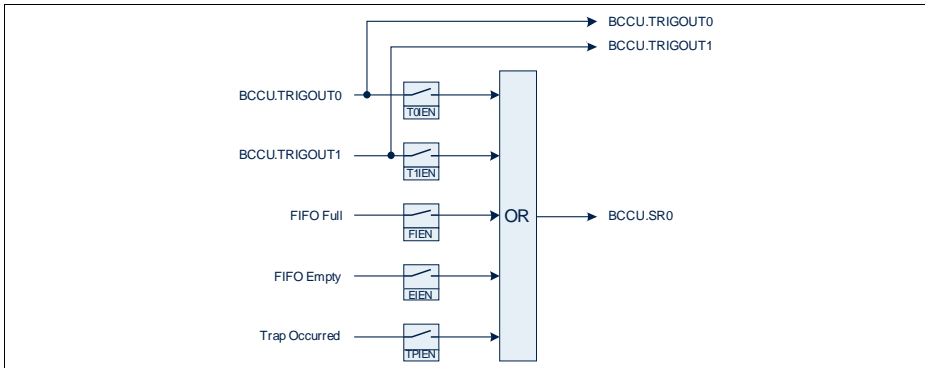
The BCCU has one service request node and five interrupts. The five interrupts are 1) Trigger 0 event, 2) Trigger 1 event, 3) Packer FIFO full event, 4) Packer FIFO empty event and 5) Trap event.

A trigger 0/1 event occurs if there is a trigger pulse on BCCU.TRIGOUT0/1 to the ADC. A packer FIFO full/empty event occurs if any of the packer FIFOs is full/empty. A trap event occurs if a rising or a falling edge is detected on the BCCU.TRAPL signal.

The five interrupts can be generated by a hardware event or by setting the respective bit in BCCU\_EVFSR. All five interrupts are assigned to node 0 and have their interrupt enable bit in BCCU\_EVIER and their flag bit in BCCU\_EVFR. The flag bits are set by the hardware event or by the respective set bits in BCCU\_EVFSR and cleared by the respective clear bits in BCCU\_EVFCR.

Additionally, the trigger events (BCCU.TRIGOUT0 and BCCU\_TRIGOUT1) are connected to the trigger inputs of the ADC.

**Brightness and Color Control Unit (BCCU)**



**Figure 20-18 Service Request Nodes**

The module clock is disabled by default and can be enabled via the SCU\_CGATCLR0 register. Enabling and disabling the module clock could cause a load change and clock blanking could occur as described in the CCU (Clock Gating Control) section of the SCU chapter. It is strongly recommended to set up the module clock in the user initialization code to avoid clock blanking during runtime.

## 20.5 Debug Behaviour

The clocks to all channels, dimming engines and other functional blocks are stopped in suspend mode. The registers can still be accessed by the CPU as read-only. This mode is useful for debugging purposes as the current device status is frozen to get a snapshot of the internal values. As the clocks are stopped, all counters and timers are stopped and frozen.

Mode of entry into suspend mode can be configured by changing the BCCU\_ **GLOBCON**.SUSCFG bitfield.

When debug suspend is revoked, the kernel resumes operation according to latest SFR settings.

*Note: In XMC1200, bit field BCCU\_ **GLOBCON**.SUSCFG is reset to its default value by any reset. If the suspend function is required during debugging, it is recommended that it is enabled in the user initialization code. Before programming the bit field, the module clock has to be enabled and special care needs to be taken while enabling the module clock as described in the CCU (Clock Gating Control) section of the SCU chapter.*

## 20.6 Initialization

The BCCU registers are recommended to be programmed in a specific sequence.

---

**Brightness and Color Control Unit (BCCU)****1. Program Global Registers**

1. BCCU\_ **CHOCON** to set output passive and active levels
2. BCCU\_ **GLOBCLK** to set up the clocks
3. BCCU\_ **GLOBCON** for general configuration
4. BCCU\_ **EVIER** to set up interrupts
5. BCCU\_ **GLOBDIM** for a user-defined dimming level when no dimming engine is used
6. BCCU\_ **CHTRIG** to set up ADC triggering

**2. Program Channel Registers**

1. BCCU\_ **CHCONFIGy (y=0-8)** for general channel configuration
2. BCCU\_ **PKCMPy (y=0-8)** if the respective packer is used
3. BCCU\_ **PKCNTRY (y=0-8)** to introduce a phase shift between channels

**3. Program Dimming Engine Registers**

1. BCCU\_ **DTTz (z=0-2)** to adjust the dimming curve

**4. Enable channels and dimming engines**

1. BCCU\_ **CHEN** to enable channels
2. BCCU\_ **DEEN** to enable dimming engines

**5. Set target intensities and start linear walk**

1. BCCU\_ **CHCONFIGy (y=0-8)**.LINPRES to set the linear walk time
2. BCCU\_ **INTSy (y=0-8)** to set the target intensities
3. BCCU\_ **CHSTRCON** to start linear walks
4. When the linear walks are finished, BCCU\_ **CHSTRCON**.CHyS are cleared by hardware

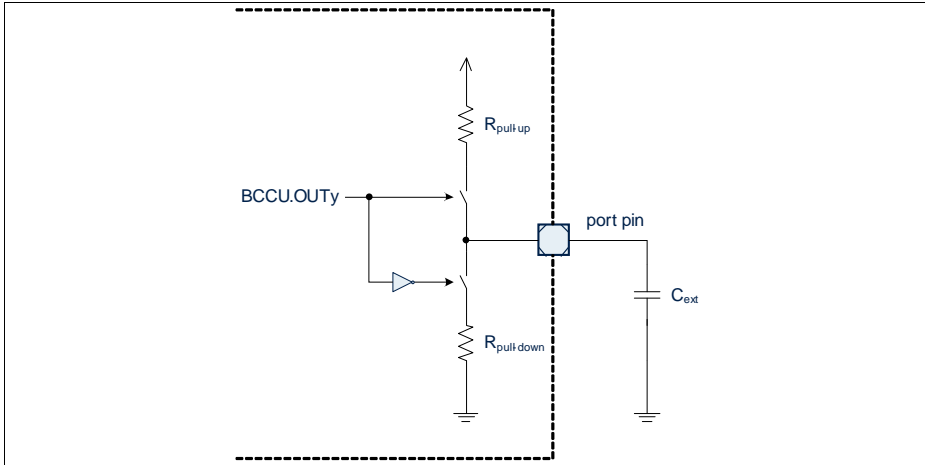
**6. Set target dimming levels and start dimming process (if at least one dimming engine is used)**

1. BCCU\_ **DTTz (z=0-2)**.DIMDIV to set the fade rate
2. BCCU\_ **DLSz (z=0-2)** to set the target target dimming levels
3. BCCU\_ **DESTRCON** to start dimming
4. When the dimming processes are completed, BCCU\_ **DESTRCON**.DEzS are cleared by hardware

**20.7 Digital-to-Analog Converter**

The BCCU can be used as a simple multi-channel Digital-to-Analog Converter (DAC) with 12-bit resolution as well. The BCCU.OUTy signals can control the pull devices of certain port pins. An RC filter can be realized by adding an external capacitor.

**Brightness and Color Control Unit (BCCU)**



**Figure 20-19 Simple DAC on one pin**

To use the BCCU in a DAC configuration, the user must ensure that the HW0 control path is selected for the port pins used. This can be done by setting the selected Pn\_HWSEL.HWx bitfields to 01<sub>B</sub>. These port pins will automatically be configured as input pins and can still be used by other modules. One example is generating an analog voltage reference for the in-built analog comparator.

It is recommended to select a high bit clock frequency by setting the fast clock prescaler (BCCU\_GLOBCLK.FCLK\_PS) to a low value and by selecting fast mode (BCCU\_GLOBCLK.BCS to 1). The selected BCCU channels should bypass the dimming engines (BCCU\_CHCONFIG (y=0-8).DBP is 1) and the flicker watchdog should be disabled (BCCU\_CHCONFIG (y=0-8).WEN to 0).

The generated voltage level can be controlled with the 12-bit channel intensity value (BCCU\_INTy (y=0-8).CHINT) by updating the target channel intensity (BCCU\_INTS (y=0-8).TCHINT) and initiating a shadow transfer (setting BCCU\_CHSTRCON.CHyS to 1).

**Brightness and Color Control Unit (BCCU)**

## 20.8 Registers

All BCCU registers (except bit field BCCU\_GLOBCON.SUSCFG) are reset by a system reset. Bit field BCCU\_GLOBCON.SUSCFG is reset by a debug reset.

### Registers Overview

The absolute register address is calculated by adding:

Module Base Address + Offset Address

**Table 20-5 Registers Address Space**

Module	Base Address	End Address	Note
BCCU	5003 0000 <sub>H</sub>	5003 FFFF <sub>H</sub>	

**Table 20-6 Register Overview**

Short Name	Description	Offset Addr.	Access Mode		Description See
			Read	Write	
BCCU Global Registers					
GLOBCON	Global Control Register	0000 <sub>H</sub>	U, PV, 32	U, PV, 32	<a href="#">Page 20-25</a>
GLOBCLK	Global Clock Register	0004 <sub>H</sub>	U, PV, 32	U, PV, 32	<a href="#">Page 20-27</a>
ID	Module Identification Register	0008 <sub>H</sub>	U, PV, 32	BE	<a href="#">Page 20-29</a>
CHEN	Channel Enable Register	000C <sub>H</sub>	U, PV, 32	U, PV, 32	<a href="#">Page 20-29</a>
CHOCON	Channel Output Control Register	0010 <sub>H</sub>	U, PV, 32	U, PV, 32	<a href="#">Page 20-30</a>
CHTRIG	Channel Trigger Register	0014 <sub>H</sub>	U, PV, 32	U, PV, 32	<a href="#">Page 20-31</a>
CHSTRCON	Channel Shadow Transfer Control Register	0018 <sub>H</sub>	U, PV, 32	U, PV, 32	<a href="#">Page 20-32</a>
LTCHOL	Last Trigger Channel Output Level Register	001C <sub>H</sub>	U, PV, 32	BE	<a href="#">Page 20-33</a>
DEEN	Dimming Engine Enable Register	0020 <sub>H</sub>	U, PV, 32	U, PV, 32	<a href="#">Page 20-33</a>
DESTRCON	Dimming Engine Shadow Transfer Control Register	0024 <sub>H</sub>	U, PV, 32	U, PV, 32	<a href="#">Page 20-34</a>

**Brightness and Color Control Unit (BCCU)**

**Table 20-6 Register Overview**

Short Name	Description	Offset Addr.	Access Mode		Description See
			Read	Write	
GLOBDIM	Global Dimming Level Register	0028 <sub>H</sub>	U, PV, 32	U, PV, 32	<a href="#">Page 20-35</a>
EVIER	Event Interrupt Enable Register	002C <sub>H</sub>	U, PV, 32	U, PV, 32	<a href="#">Page 20-36</a>
EVFR	Event Flag Register	0030 <sub>H</sub>	U, PV, 32	BE	<a href="#">Page 20-37</a>
EVFSR	Event Flag Set Register	0034 <sub>H</sub>	U, PV, 32	U, PV, 32	<a href="#">Page 20-38</a>
EVFCR	Event Flag Clear Register	0038 <sub>H</sub>	U, PV, 32	U, PV, 32	<a href="#">Page 20-39</a>

**BCCU Channel Registers**

INTSy	Channel Intensity Shadow Register y	003C <sub>H</sub> + y*0014 <sub>H</sub>	U, PV, 32	U, PV, 32	<a href="#">Page 20-41</a>
INTy	Channel Intensity Register y	0040 <sub>H</sub> + y*0014 <sub>H</sub>	U, PV, 32	BE	<a href="#">Page 20-41</a>
CHCONFIGy	Channel Configuration Register y	0044 <sub>H</sub> + y*0014 <sub>H</sub>	U, PV, 32	U, PV, 32	<a href="#">Page 20-42</a>
PKCMPy	Packer Compare Register y	0048 <sub>H</sub> + y*0014 <sub>H</sub>	U, PV, 32	U, PV, 32	<a href="#">Page 20-44</a>
PKCNTRY	Packer Counter Register y	004C <sub>H</sub> + y*0014 <sub>H</sub>	U, PV, 32	U, PV, 32	<a href="#">Page 20-45</a>
Reserved	Reserved	00F0 <sub>H</sub> - 0178 <sub>H</sub>	BE	BE	

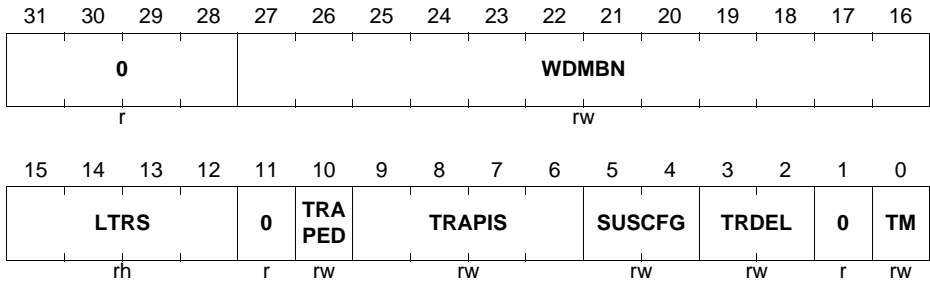
**BCCU Dimming Engine Registers**

DLSz	Dimming Level Shadow Register z	017C <sub>H</sub> + z*000C <sub>H</sub>	U, PV, 32	U, PV, 32	<a href="#">Page 20-46</a>
DLz	Dimming Level Register z	0180 <sub>H</sub> + z*000C <sub>H</sub>	U, PV, 32	BE	<a href="#">Page 20-46</a>
DTTz	Dimming Transition Time Register z	0184 <sub>H</sub> + z*000C <sub>H</sub>	U, PV, 32	U, PV, 32	<a href="#">Page 20-47</a>
Reserved	Reserved	01A0 <sub>H</sub> - FFFC <sub>H</sub>	BE	BE	

**Brightness and Color Control Unit (BCCU)**

**20.8.1 Global Registers**

**GLOBCON**  
Global Control (0000<sub>H</sub>) Reset Value: 0320 0000<sub>H</sub>



Field	Bits	Type	Description
<b>TM</b>	0	rw	<b>Trigger Mode</b> 0 <sub>B</sub> Mode 0: BCCU trigger occurs if there is any channel trigger (OR logic) 1 <sub>B</sub> Mode 1: BCCU trigger occurs if there is a channel trigger event on the active channel. When this happens, the next trigger-enabled channel will be active following the round robin.
<b>0</b>	1	r	<b>Reserved</b> Read as 0; should be written with 0.
<b>TRDEL</b>	[3:2]	rw	<b>Trigger Delay</b> 00 <sub>B</sub> No delay 01 <sub>B</sub> BCCU trigger occurs a quarter bit time after the channel trigger that caused it; only to be used if BCCU_GLOBCLK.BCS is 0 10 <sub>B</sub> BCCU trigger occurs half a bit time after the channel trigger that caused it; only to be used if BCCU_GLOBCLK.BCS is 0 11 <sub>B</sub> No delay



**Brightness and Color Control Unit (BCCU)**

Field	Bits	Type	Description
<b>SUSCFG</b>	[5:4]	rw	<p><b>Suspend Mode Configuration</b></p> <p>This bitfield determines how the BCCU channels enter suspend mode.</p> <p>00<sub>B</sub> Suspend request is ignored and the module cannot get suspended</p> <p>01<sub>B</sub> All channels stop running immediately and freeze in the last state without any safe stop</p> <p>10<sub>B</sub> All channels stop running immediately and freeze in the last state; all outputs go to passive state to achieve safe stop</p> <p>11<sub>B</sub> Reserved</p>
<b>TRAPIS</b>	[9:6]	rw	<p><b>Trap Input Pin Selector</b></p> <p>Source of the trap input (BCCU.TRAPL)</p> <p>0000<sub>B</sub> BCCU.TRAPINA</p> <p>0001<sub>B</sub> BCCU.TRAPINB</p> <p>0010<sub>B</sub> BCCU.TRAPINC</p> <p>0011<sub>B</sub> BCCU.TRAPIND</p> <p>0100<sub>B</sub> BCCU.TRAPINE</p> <p>0101<sub>B</sub> BCCU.TRAPINF</p> <p>0110<sub>B</sub> BCCU.TRAPING</p> <p>0111<sub>B</sub> BCCU.TRAPINH</p> <p>1000<sub>B</sub> BCCU.TRAPINI</p> <p>1001<sub>B</sub> BCCU.TRAPINJ</p> <p>1010<sub>B</sub> BCCU.TRAPINK</p> <p>1011<sub>B</sub> BCCU.TRAPINL</p> <p>1100<sub>B</sub> BCCU.TRAPINM</p> <p>1101<sub>B</sub> BCCU.TRAPINN</p> <p>1110<sub>B</sub> BCCU.TRAPINO</p> <p>1111<sub>B</sub> BCCU.TRAPINP</p>
<b>TRAPED</b>	10	rw	<p><b>Trap Edge</b></p> <p>0<sub>B</sub> Trap occurs (trap flag is set) on rising edge of the BCCU.TRAPL signal</p> <p>1<sub>B</sub> Trap occurs (trap flag is set) on falling edge of the BCCU.TRAPL signal</p>
<b>0</b>	11	r	<p><b>Reserved</b></p> <p>Read as 0; should be written with 0.</p>

**Brightness and Color Control Unit (BCCU)**

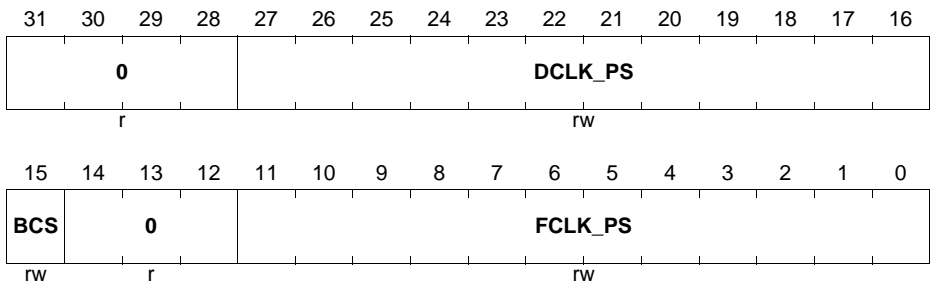
Field	Bits	Type	Description
<b>LTRS</b>	[15:12]	rh	<b>Last Trigger Source</b> Shows which channel generated the last trigger (the value is always 0 in Trigger Mode 0) 0000 <sub>B</sub> The last trigger occurred in channel turn 0 0001 <sub>B</sub> The last trigger occurred in channel turn 1 0010 <sub>B</sub> The last trigger occurred in channel turn 2 0011 <sub>B</sub> The last trigger occurred in channel turn 3 0100 <sub>B</sub> The last trigger occurred in channel turn 4 0101 <sub>B</sub> The last trigger occurred in channel turn 5 0110 <sub>B</sub> The last trigger occurred in channel turn 6 0111 <sub>B</sub> The last trigger occurred in channel turn 7 1000 <sub>B</sub> The last trigger occurred in channel turn 8
<b>WDMBN</b>	[27:16]	rw	<b>Watchdog Maximum Bitnumber</b> The maximum number of consecutive zeroes allowed at the output of the sigma-delta modulators
<b>0</b>	[31:28]	r	<b>Reserved</b> Read as 0; should be written with 0.

**GLOBCLK**

**Global Clock**

**(0004<sub>H</sub>)**

**Reset Value: 00DB 0190<sub>H</sub>**



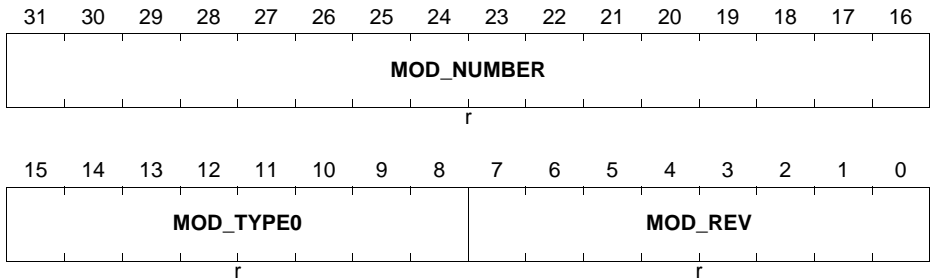
**Brightness and Color Control Unit (BCCU)**

Field	Bits	Type	Description
<b>FCLK_PS</b>	[11:0]	rw	<p><b>Fast Clock Prescaler Factor</b></p> <p>The constant clock input to the BCCU is prescaled according to this value to generate BCCU_fclk. BCCU_bclk is generated from BCCU_fclk by a division of 4. BCCU_bclk determines the bit-time at the output of the sigma-delta modulators.</p> <p>0<sub>D</sub> No clock            1<sub>D</sub> Divide by 1            ...            4095<sub>D</sub> Divide by 4095</p>
<b>BCS</b>	15	rw	<p><b>Bit-Clock Selector</b></p> <p>0<sub>B</sub> Normal Mode: BCCU_bclk is generated from BCCU_fclk by a division of 4            1<sub>B</sub> Fast Mode: BCCU_bclk is the same as BCCU_fclk</p>
<b>0</b>	[14:12]	r	<p><b>Reserved</b></p> <p>Read as 0; should be written with 0.</p>
<b>DCLK_PS</b>	[27:16]	rw	<p><b>Dimmer Clock Prescaler Factor</b></p> <p>The constant clock input to the BCCU is prescaled according to this value to generate BCCU_dclk which is the clock input to the dimming engines.</p> <p>0<sub>D</sub> No clock            1<sub>D</sub> Divide by 1            ...            4095<sub>D</sub> Divide by 4095</p>
<b>0</b>	[31:28]	r	<p><b>Reserved</b></p> <p>Read as 0; should be written with 0.</p>

**Brightness and Color Control Unit (BCCU)**

**ID**

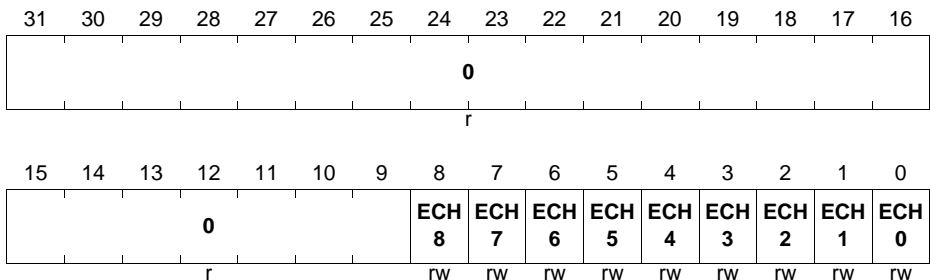
**Module Identification** (0008<sub>H</sub>) **Reset Value: 00F3 C0XX<sub>H</sub>**



Field	Bits	Type	Description
MOD_REV	[7:0]	r	<b>Module Revision Number</b> MOD_REV defines the revision number. The value of a module revision starts with 01 <sub>H</sub> (first revision).
MOD_TYPE0	[15:8]	r	<b>Module Type</b> This bit field is C0 <sub>H</sub> . It defines the module as a 32-bit module.
MOD_NUMBER	[31:16]	r	<b>Module Number Value</b> This bit field defines the module identification number.

**CHEN**

**Channel Enable** (000C<sub>H</sub>) **Reset Value: 0000 0000<sub>H</sub>**



**Brightness and Color Control Unit (BCCU)**

Field	Bits	Type	Description
<b>ECHy</b> <b>(y=0-8)</b>	y	rw	<b>Channel y Enable</b> 0 <sub>B</sub> Channel is disabled, the output level is passive; the Linear Walker and the Sigma-Delta Modulator are reset, the Packer FIFO is flushed; all internal logic and INTy are reset when the channel gets disabled 1 <sub>B</sub> Channel is enabled
<b>0</b>	[31:9]	r	<b>Reserved</b> Read as 0; should be written with 0.

**CHOCON**

**Channel Output Control**

**(0010<sub>H</sub>)**

**Reset Value: 0000 0000<sub>H</sub>**

31	30	29	28	27	26	25	24	23	22	21	20	19	18	17	16
			0				CH8 TPE	CH7 TPE	CH6 TPE	CH5 TPE	CH4 TPE	CH3 TPE	CH2 TPE	CH1 TPE	CH0 TPE
			r				rw	rw	rw	rw	rw	rw	rw	rw	rw
15	14	13	12	11	10	9	8	7	6	5	4	3	2	1	0
			0				CH8 OP	CH7 OP	CH6 OP	CH5 OP	CH4 OP	CH3 OP	CH2 OP	CH1 OP	CH0 OP
			r				rw	rw	rw	rw	rw	rw	rw	rw	rw

Field	Bits	Type	Description
<b>CHyOP</b> <b>(y=0-8)</b>	y	rw	<b>Channel y Output Passive Level</b> 0 <sub>B</sub> Active high 1 <sub>B</sub> Active low
<b>0</b>	[15:9]	r	<b>Reserved</b> Read as 0; should be written with 0.
<b>CHyTPE</b> <b>(y=0-8)</b>	y+16	rw	<b>Channel y Trap Enable</b> 0 <sub>B</sub> Trap function on channel is disabled 1 <sub>B</sub> Trap function on channel is enabled, the output goes to passive level when trap occurs
<b>0</b>	[31:25]	r	<b>Reserved</b> Read as 0; should be written with 0.

**Brightness and Color Control Unit (BCCU)**

**CHTRIG**

**Channel Trigger**

**(0014<sub>H</sub>)**

**Reset Value: 0000 0000<sub>H</sub>**

31	30	29	28	27	26	25	24	23	22	21	20	19	18	17	16
0							TOS	TOS	TOS	TOS	TOS	TOS	TOS	TOS	TOS
							8	7	6	5	4	3	2	1	0
r							rw	rw	rw	rw	rw	rw	rw	rw	rw
15	14	13	12	11	10	9	8	7	6	5	4	3	2	1	0
0							ET8	ET7	ET6	ET5	ET4	ET3	ET2	ET1	ET0
r							rw	rw	rw	rw	rw	rw	rw	rw	rw

Field	Bits	Type	Description
<b>ETy</b> <b>(y=0-8)</b>	y	rw	<b>Channel y Trigger Enable</b> 0 <sub>B</sub> Channel trigger is disabled 1 <sub>B</sub> Channel trigger is enabled If all Channel y Trigger Enable bits are 0, then the channel pointer is reset and points to channel 0.
<b>0</b>	[15:9]	r	<b>Reserved</b> Read as 0; should be written with 0.
<b>TOSy</b> <b>(y=0-8)</b>	y+16	rw	<b>Channel y Trigger Output Select</b> Only used in Trigger Mode 1 (GLOBON.TM=1), otherwise ignored 0 <sub>B</sub> The channel trigger pulse will appear on BCCU_TRIGOUT0 1 <sub>B</sub> The channel trigger pulse will appear on BCCU_TRIGOUT1
<b>0</b>	[31:25]	r	<b>Reserved</b> Read as 0; should be written with 0.

**Brightness and Color Control Unit (BCCU)**

**CHSTRCON**

**Channel Shadow Transfer**

**(0018<sub>H</sub>)**

**Reset Value: 0000 0000<sub>H</sub>**

31	30	29	28	27	26	25	24	23	22	21	20	19	18	17	16
0							CH8	CH7	CH6	CH5	CH4	CH3	CH2	CH1	CH0
r							A	A	A	A	A	A	A	A	A
							w	w	w	w	w	w	w	w	w
15	14	13	12	11	10	9	8	7	6	5	4	3	2	1	0
0							CH8	CH7	CH6	CH5	CH4	CH3	CH2	CH1	CH0
r							S	S	S	S	S	S	S	S	S
							rwh	rwh	rwh	rwh	rwh	rwh	rwh	rwh	rwh

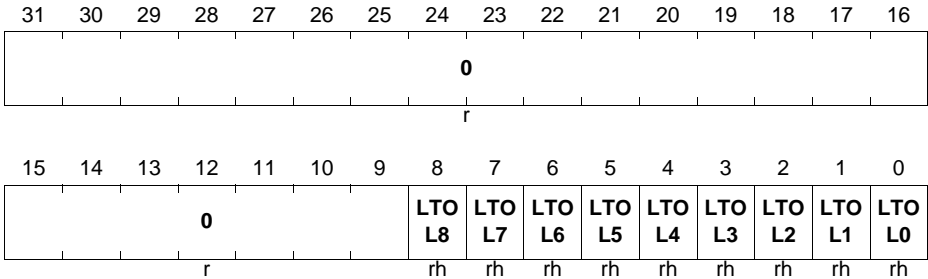
Field	Bits	Type	Description
<b>CHyS</b> <b>(y=0-8)</b>	y	rwh	<b>Channel y Shadow Transfer</b> 0 <sub>B</sub> No action 1 <sub>B</sub> Initiate channel y target intensity shadow transfer. The linear walk will start and channel y intensity will start to change towards the target. Cleared by hardware when the linear walk is complete and the target has been reached.
<b>0</b>	[15:9]	r	<b>Reserved</b> Read as 0; should be written with 0.
<b>CHyA</b> <b>(y=0-8)</b>	y+16	w	<b>Channel y Linear Walk Abort</b> 0 <sub>B</sub> No action 1 <sub>B</sub> Abort linear walk; CHyS is cleared, channel y intensity stops changing Always read as 0
<b>0</b>	[31:25]	r	<b>Reserved</b> Read as 0; should be written with 0.

**Brightness and Color Control Unit (BCCU)**

**LTCHOL**

**Last Trigger Channel Output Level (001C<sub>H</sub>)**

**Reset Value: 0000 0000<sub>H</sub>**

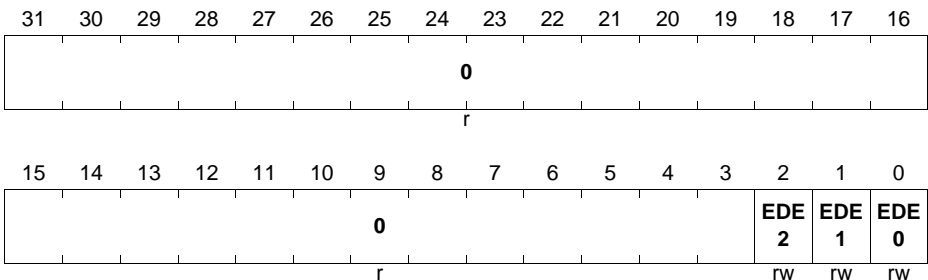


Field	Bits	Type	Description
<b>LTOLy</b> (y=0-8)	y	rh	<b>Last Trigger Channel Output</b> The output level of the channel when the last trigger occurred. The bit gets updated with every BCCU trigger in Trigger Mode 0. In Trigger Mode 1, the bit gets updated when a trigger occurs in the relevant channel turn. 0 <sub>B</sub> Passive 1 <sub>B</sub> Active
<b>0</b>	[31:9]	r	<b>Reserved</b> Read as 0; should be written with 0.

**DEEN**

**Dimming Engine Enable (0020<sub>H</sub>)**

**Reset Value: 0000 0000<sub>H</sub>**





**Brightness and Color Control Unit (BCCU)**

Field	Bits	Type	Description
<b>EDEz</b> <b>(z=0-2)</b>	z	rw	<b>Dimming Engine z Enable</b> 0 <sub>B</sub> Dimming Engine is disabled; the output dimming level (DLz.DLEV) is reset to 0 when the dimming engine gets disabled 1 <sub>B</sub> Dimming Engine is enabled
<b>0</b>	[31:3]	r	<b>Reserved</b> Read as 0; should be written with 0.

**DESTRCON**

**Dimming Shadow Transfer (0024<sub>H</sub>) Reset Value: 0000 0000<sub>H</sub>**

31	30	29	28	27	26	25	24	23	22	21	20	19	18	17	16
0												DE2 A	DE1 A	DE0 A	
r												w	w	w	
15	14	13	12	11	10	9	8	7	6	5	4	3	2	1	0
0												DE2 S	DE1 S	DE0 S	
r												rwh	rwh	rwh	

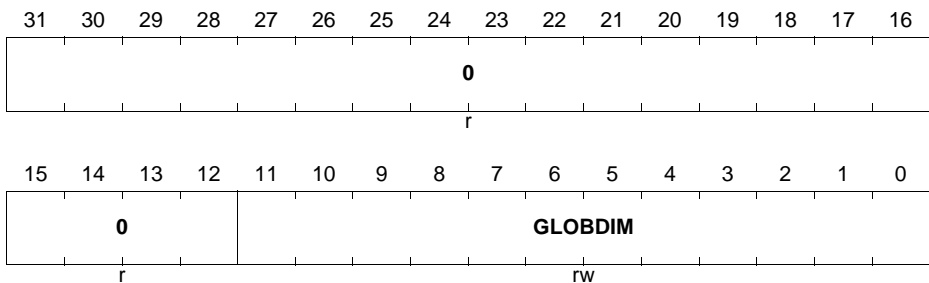
Field	Bits	Type	Description
<b>DEzS</b> <b>(z=0-2)</b>	z	rwh	<b>Dimming Engine z Shadow Transfer</b> 0 <sub>B</sub> No action 1 <sub>B</sub> Initiate target dimming level shadow transfer. The dimming process will start and the dimming level will change towards the target. Cleared by hardware when the dimming process is complete and the target has been reached.
<b>0</b>	[15:3]	r	<b>Reserved</b> Read as 0; should be written with 0.

**Brightness and Color Control Unit (BCCU)**

Field	Bits	Type	Description
<b>DEzA</b> <b>(z=0-2)</b>	z+16	w	<b>Dimming Engine z Dimming Abort</b> 0 <sub>B</sub> No action 1 <sub>B</sub> Abort dimming; DEzS is cleared, BCCU_DLz.DLEV stops changing Always read as 0
<b>0</b>	[31:19]	r	<b>Reserved</b> Read as 0; should be written with 0.

**GLOBDIM**

**Global Dimming Level (0028<sub>H</sub>) Reset Value: 0000 0000<sub>H</sub>**



Field	Bits	Type	Description
<b>GLOBDIM</b>	[11:0]	rw	<b>Global Dimming Level</b> Can be used for software-controlled dimming
<b>0</b>	[31:12]	r	<b>Reserved</b> Read as 0; should be written with 0.

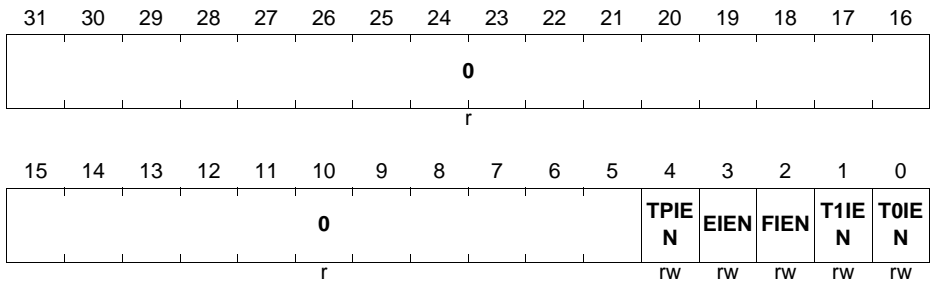
**Brightness and Color Control Unit (BCCU)**

**EVIER**

**Event Interrupt Enable**

**(002C<sub>H</sub>)**

**Reset Value: 0000 0000<sub>H</sub>**



Field	Bits	Type	Description
<b>TOIEN</b>	0	rw	<p><b>Trigger 0 Interrupt Enable</b></p> <p>0<sub>B</sub> Trigger 0 interrupt generation is disabled</p> <p>1<sub>B</sub> BCCU trigger 0 (BCCU_TRIGOUT0) generates an interrupt on SR0</p>
<b>T1IEN</b>	1	rw	<p><b>Trigger 1 Interrupt Enable</b></p> <p>0<sub>B</sub> Trigger 1 interrupt generation is disabled</p> <p>1<sub>B</sub> BCCU trigger 1 (BCCU_TRIGOUT1) generates an interrupt on SR0</p>
<b>FIEN</b>	2	rw	<p><b>FIFO Full Interrupt Enable</b></p> <p>0<sub>B</sub> FIFO-full interrupt generation is disabled</p> <p>1<sub>B</sub> An interrupt is generated on SR0 if any of the packer FIFOs is full when there is a write attempt by the on-time or off-time counter</p>
<b>EIEN</b>	3	rw	<p><b>FIFO Empty Interrupt Enable</b></p> <p>0<sub>B</sub> FIFO-full interrupt generation is disabled</p> <p>1<sub>B</sub> An interrupt is generated on SR0 if any of the packer FIFOs is empty when there is a read attempt by the output generator</p>
<b>TPIEN</b>	4	rw	<p><b>Trap Interrupt Enable</b></p> <p>0<sub>B</sub> Trap interrupt generation is disabled</p> <p>1<sub>B</sub> An interrupt is generated on SR0 if a trap occurs</p>
<b>0</b>	[31:5]	r	<p><b>Reserved</b></p> <p>Read as 0; should be written with 0.</p>

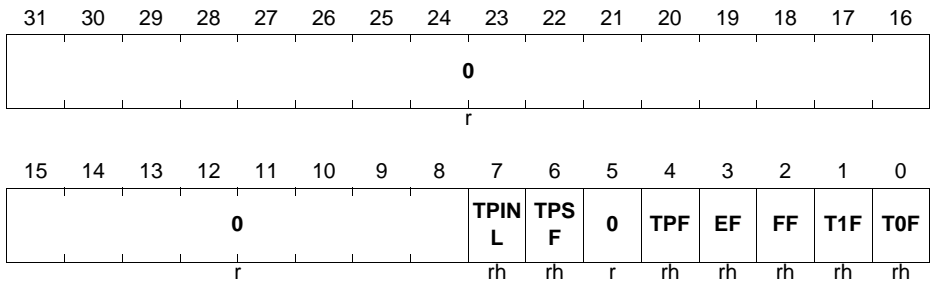
**Brightness and Color Control Unit (BCCU)**

**EVFR**

**Event Flag**

**(0030<sub>H</sub>)**

**Reset Value: 0000 0000<sub>H</sub>**



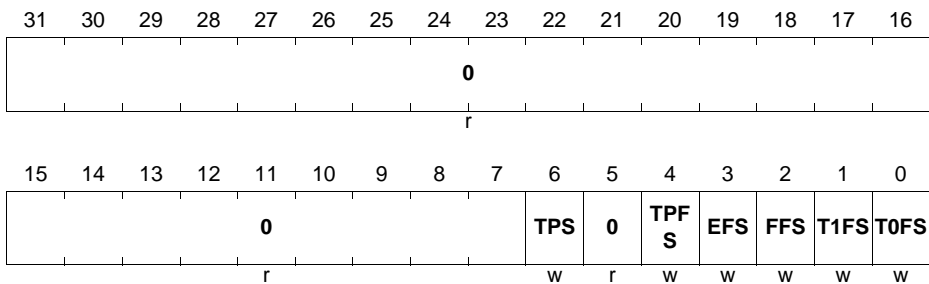
Field	Bits	Type	Description
<b>T0F</b>	0	rh	<p><b>Trigger 0 Flag</b></p> <p>0<sub>B</sub> No trigger event has been detected on BCCU trigger line 0 (BCCU_TRIGOUT0)</p> <p>1<sub>B</sub> A trigger event has been detected on BCCU trigger line 0 (BCCU_TRIGOUT0)</p>
<b>T1F</b>	1	rh	<p><b>Trigger 1 Flag</b></p> <p>0<sub>B</sub> No trigger event has been detected on BCCU trigger line 1 (BCCU_TRIGOUT1)</p> <p>1<sub>B</sub> A trigger event has been detected on BCCU trigger line 1 (BCCU_TRIGOUT1)</p>
<b>FF</b>	2	rh	<p><b>FIFO Full Flag</b></p> <p>0<sub>B</sub> No FIFO full event has been detected</p> <p>1<sub>B</sub> A FIFO full event has been detected because one of the packer FIFOs is full and there has been a write attempt by the on-time or off-time counter</p>
<b>EF</b>	3	rh	<p><b>FIFO Empty Flag</b></p> <p>0<sub>B</sub> No FIFO full event has been detected</p> <p>1<sub>B</sub> A FIFO full event has been detected because one of the packer FIFOs is empty and there has been a read attempt by the output generator</p>
<b>TPF</b>	4	rh	<p><b>Trap Flag</b></p> <p>0<sub>B</sub> No trap event has been detected</p> <p>1<sub>B</sub> A trap event has been detected</p>

**Brightness and Color Control Unit (BCCU)**

Field	Bits	Type	Description
<b>0</b>	5	r	<b>Reserved</b> Read as 0; should be written with 0.
<b>TPSF</b>	6	rh	<b>Trap State Flag</b> 0 <sub>B</sub> BCCU is not in a trap state 1 <sub>B</sub> BCCU is in a trap state, the affected channel outputs are at their passive levels
<b>TPINL</b>	7	rh	<b>Trap Input Level</b> 0 <sub>B</sub> The current level of BCCU.TRAPL is low 1 <sub>B</sub> The current level of BCCU.TRAPL is high
<b>0</b>	[31:8]	r	<b>Reserved</b> Read as 0; should be written with 0.

**EVFSR**

**Event Flag Set (0034<sub>H</sub>) Reset Value: 0000 0000<sub>H</sub>**



Field	Bits	Type	Description
<b>T0FS</b>	0	w	<b>Trigger 0 Flag Set</b> 0 <sub>B</sub> No action 1 <sub>B</sub> Sets the Trigger 0 Flag in EVFR and an interrupt will be generated if enabled in EVIER
<b>T1FS</b>	1	w	<b>Trigger 1 Flag Set</b> 0 <sub>B</sub> No action 1 <sub>B</sub> Sets the Trigger 1 Flag in EVFR and an interrupt will be generated if enabled in EVIER

**Brightness and Color Control Unit (BCCU)**

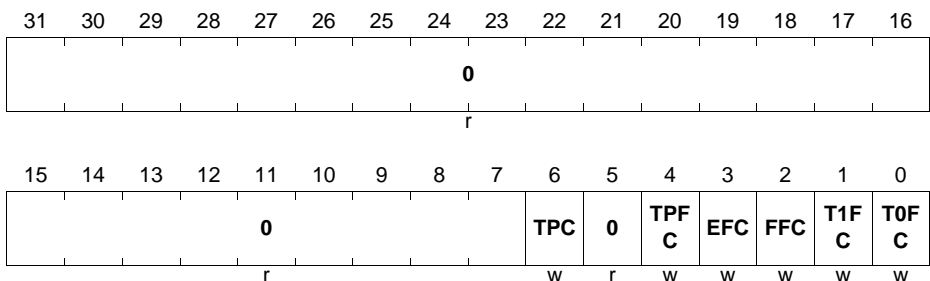
Field	Bits	Type	Description
<b>FFS</b>	2	w	<b>FIFO Full Flag Set</b> 0 <sub>B</sub> No action 1 <sub>B</sub> Sets the FIFO Full Flag in EVFR and an interrupt will be generated if enabled in EVIER
<b>EFS</b>	3	w	<b>FIFO Empty Flag Set</b> 0 <sub>B</sub> No action 1 <sub>B</sub> Sets the FIFO Empty Flag in EVFR and an interrupt will be generated if enabled in EVIER
<b>TPFS</b>	4	w	<b>Trap Flag Set</b> 0 <sub>B</sub> No action 1 <sub>B</sub> Sets the Trap Flag in EVFR and an interrupt will be generated if enabled in EVIER, no trap will occur
<b>0</b>	5	r	<b>Reserved</b> Read as 0; should be written with 0.
<b>TPS</b>	6	w	<b>Trap Set</b> 0 <sub>B</sub> No action 1 <sub>B</sub> Sets the Trap State Flag and Trap Flag in EVFR, a trap will be generated and an interrupt will be generated if enabled in EVIER
<b>0</b>	[31:7]	r	<b>Reserved</b> Read as 0; should be written with 0.

**EVFCR**

**Event Flag Clear**

**(0038<sub>H</sub>)**

**Reset Value: 0000 0000<sub>H</sub>**



**Brightness and Color Control Unit (BCCU)**

Field	Bits	Type	Description
<b>T0FC</b>	0	w	<b>Trigger 0 Flag Clear</b> 0 <sub>B</sub> No action 1 <sub>B</sub> Clears the Trigger 0 Flag in EVFR
<b>T1FC</b>	1	w	<b>Trigger 1 Flag Clear</b> 0 <sub>B</sub> No action 1 <sub>B</sub> Clears the Trigger 1 Flag in EVFR
<b>FFC</b>	2	w	<b>FIFO Full Flag Clear</b> 0 <sub>B</sub> No action 1 <sub>B</sub> Clears the FIFO Full Flag in EVFR
<b>EFC</b>	3	w	<b>FIFO Empty Flag Clear</b> 0 <sub>B</sub> No action 1 <sub>B</sub> Clears the FIFO Empty Flag in EVFR
<b>TPFC</b>	4	w	<b>Trap Flag Clear</b> 0 <sub>B</sub> No action 1 <sub>B</sub> Clears the Trap Flag in EVFR
<b>0</b>	5	r	<b>Reserved</b> Read as 0; should be written with 0.
<b>TPC</b>	6	w	<b>Trap Clear</b> 0 <sub>B</sub> No action 1 <sub>B</sub> Clears the Trap State Flag in EVFR; trap state is exited, the affected channels will return to their normal output levels
<b>0</b>	[31:7]	r	<b>Reserved</b> Read as 0; should be written with 0.

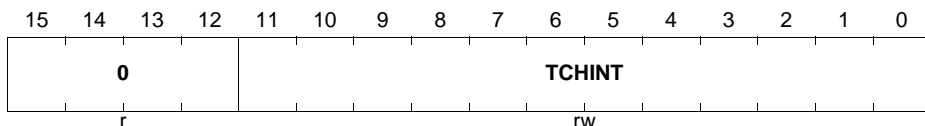
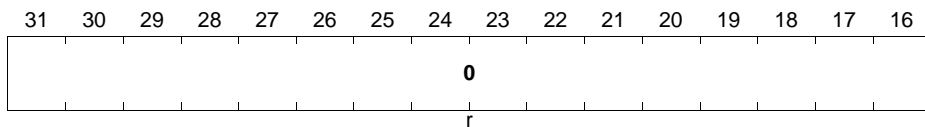
## 20.8.2 Channel Registers

There are 9 channels available on XMC1200. y denotes channel 0 through 8.

**Brightness and Color Control Unit (BCCU)**

**INTSy (y=0-8)**

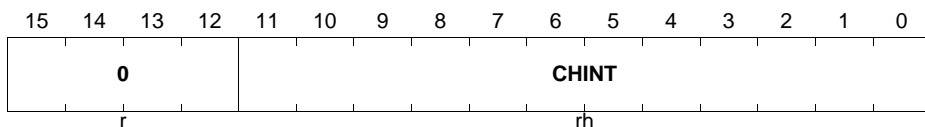
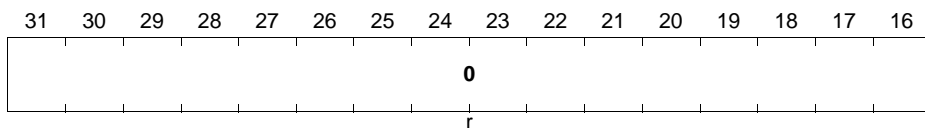
**Channel Intensity Shadow**       $(003C_H + y*0014_H)$       **Reset Value: 0000 0000<sub>H</sub>**



Field	Bits	Type	Description
<b>TCHINT</b>	[11:0]	rw	<b>Target Channel Intensity</b> Can only be written if CHSTRCON.CHyS is not set, otherwise the new value will be ignored.
<b>0</b>	[31:12]	r	<b>Reserved</b> Read as 0; should be written with 0.

**INTy (y=0-8)**

**Channel Intensity**       $(0040_H + y*0014_H)$       **Reset Value: 0000 0000<sub>H</sub>**



Field	Bits	Type	Description
<b>CHINT</b>	[11:0]	rh	<b>Channel Intensity</b> Actual channel intensity.



**Brightness and Color Control Unit (BCCU)**

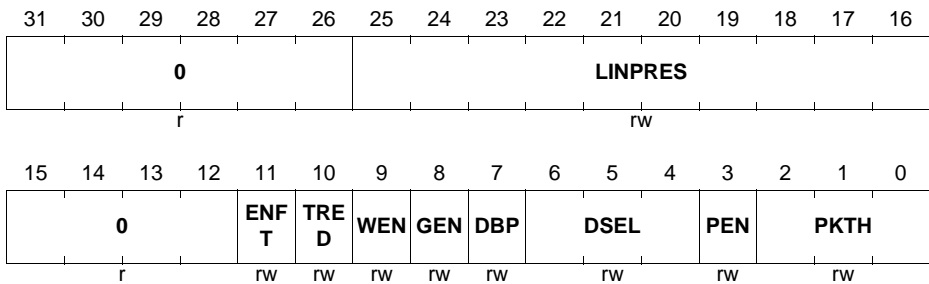
Field	Bits	Type	Description
<b>0</b>	[31:12]	r	<b>Reserved</b> Read as 0; should be written with 0.

**CHCONFIGy (y=0-8)**

**Channel Configuration**

**(0044<sub>H</sub> + y\*0014<sub>H</sub>)**

**Reset Value: 0000 0002<sub>H</sub>**



Field	Bits	Type	Description
<b>PKTH</b>	[2:0]	rw	<b>Packer Threshold</b> After being enabled, the packer will start generating the output based on the values stored in the FIFO (queue) once the number of full stages reaches this threshold (until that only zeros are generated).
<b>PEN</b>	3	rw	<b>Packer Enable</b> 0 <sub>B</sub> The packer is not used 1 <sub>B</sub> On-time and off-time counters are running and the packed output bitstream with the packer trigger are generated.
<b>DSEL</b>	[6:4]	rw	<b>Dimming Select</b> Source of the dimming input 000 <sub>B</sub> Dimming Engine 0 001 <sub>B</sub> Dimming Engine 1 010 <sub>B</sub> Dimming Engine 2 011 <sub>B</sub> Reserved 100 <sub>B</sub> Reserved 101 <sub>B</sub> Reserved 110 <sub>B</sub> Reserved 111 <sub>B</sub> Global Dimming Level

**Brightness and Color Control Unit (BCCU)**

Field	Bits	Type	Description
<b>DBP</b>	7	rw	<p><b>Dimming Input Bypass</b></p> <p>0<sub>B</sub> Channel brightness is the product of the selected dimming input and the channel intensity</p> <p>1<sub>B</sub> No dimming input is used, channel brightness is only determined by the channel intensity level</p>
<b>GEN</b>	8	rw	<p><b>Gating Enable</b></p> <p>0<sub>B</sub> Gating function is disabled, the input signal (BCCU.INy) has no effect</p> <p>1<sub>B</sub> Gating function is enabled, the output gating signal is BCCU.INy</p>
<b>WEN</b>	9	rw	<p><b>Flicker Watchdog Enable</b></p> <p>0<sub>B</sub> The flicker watchdog is not used</p> <p>1<sub>B</sub> The flicker watchdog is active and limits the number of consecutive zeroes at the sigma-delta modulator output according to GLOBCON.WDMBN</p>
<b>TRED</b>	10	rw	<p><b>Trigger Edge</b></p> <p>0<sub>B</sub> Channel triggers occur on channel output transition from passive to active level</p> <p>1<sub>B</sub> Channel triggers occur on channel output transition from active to passive level</p>
<b>ENFT</b>	11	rw	<p><b>Forced Trigger Enable</b></p> <p>0<sub>B</sub> No forced trigger is generated</p> <p>1<sub>B</sub> The trigger generator generates a trigger if the output of the sigma-delta modulator hasn't changed state for 256 bit times; only takes effect if the packer is disabled (PEN=0)</p>
<b>0</b>	[15:12]	r	<p><b>Reserved</b></p> <p>Read as 0; should be written with 0.</p>
<b>LINPRES</b>	[25:16]	rw	<p><b>Linear Walker Clock Prescaler</b></p> <p>Determines how long it takes for the Channel Intensity to reach the Target Channel Intensity after shadow transfer (after CHSTRCON.CHyS is set). Necessary for smooth linear color transitions. If this value is 0, then the intensity level will become the same as the target intensity level on shadow transfer and the linear walker is bypassed.</p>

**Brightness and Color Control Unit (BCCU)**

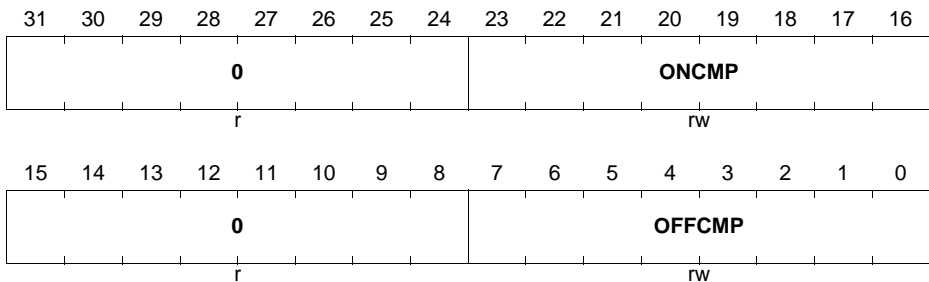
Field	Bits	Type	Description
<b>0</b>	[31:26]	r	<b>Reserved</b> Read as 0; should be written with 0.

**PKCMPy (y=0-8)**

**Packer Compare**

$$(0048_H + y * 0014_H)$$

**Reset Value: 0027 00FF<sub>H</sub>**



Field	Bits	Type	Description
<b>OFFCMP</b>	[7:0]	rw	<b>Packer Off-Time Compare Level</b> When the off-time counter in the packer reaches this value, the measured on-time and off-time of the output of the sigma-delta modulator are stored; and the counters reset to 0.
<b>0</b>	[15:8]	r	<b>Reserved</b> Read as 0; should be written with 0.
<b>ONCMP</b>	[23:16]	rw	<b>Packer On-Time Compare Level</b> When the on-time counter in the packer reaches this value, the measured on-time and off-time of the output of the sigma-delta modulator are stored; and the counters reset to 0.
<b>0</b>	[31:24]	r	<b>Reserved</b> Read as 0; should be written with 0.

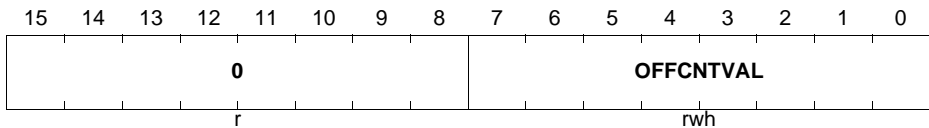
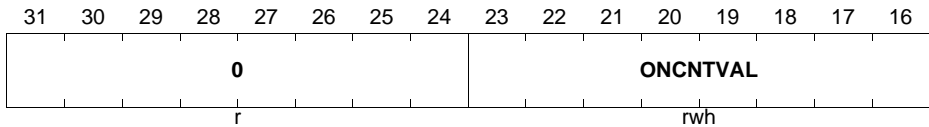
**Brightness and Color Control Unit (BCCU)**

**PKCNTRY (y=0-8)**

**Packer Counter**

**(004C<sub>H</sub> + y\*0014<sub>H</sub>)**

**Reset Value: 0000 0000<sub>H</sub>**



Field	Bits	Type	Description
<b>OFFCNTVAL</b>	[7:0]	rwh	<b>Off-Time Counter Value</b> Can be written when the channel is disabled (CHEN.ECHy is 0), otherwise write accesses are ignored.
<b>0</b>	[15:8]	r	<b>Reserved</b> Read as 0; should be written with 0.
<b>ONCNTVAL</b>	[23:16]	rwh	<b>On-Time Counter Value</b> Can be written when the channel is disabled (CHEN.ECHy is 0), otherwise write accesses are ignored.
<b>0</b>	[31:24]	r	<b>Reserved</b> Read as 0; should be written with 0.

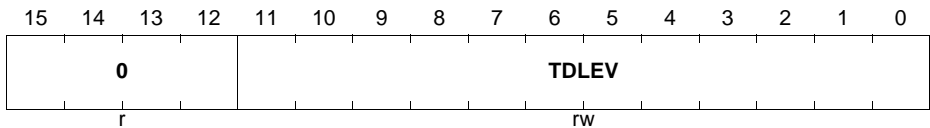
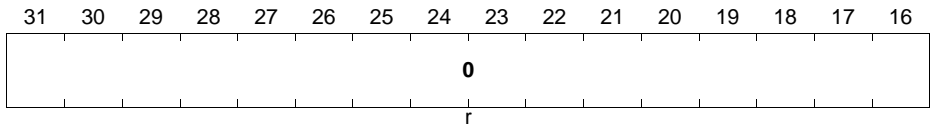
### 20.8.3 Dimming Engine Registers

There are 3 dimming engines available on XMC1200. z denotes engine 0 through 2.

**Brightness and Color Control Unit (BCCU)**

**DLsz (z=0-2)**

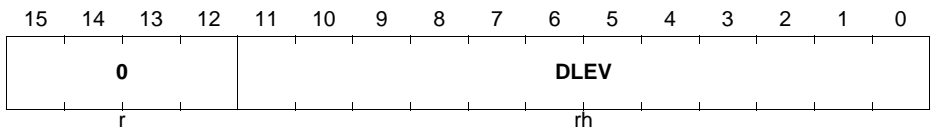
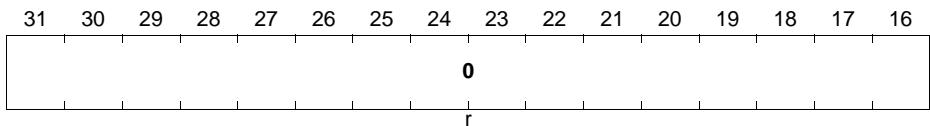
**Dimming Level Shadow** (017C<sub>H</sub> + z\*000C<sub>H</sub>) **Reset Value: 0000 0000<sub>H</sub>**



Field	Bits	Type	Description
TDLEV	[11:0]	rw	Target Dimming Level
0	[31:12]	r	Reserved Read as 0; should be written with 0.

**DLz (z=0-2)**

**Dimming Level** (0180<sub>H</sub> + z\*000C<sub>H</sub>) **Reset Value: 0000 0000<sub>H</sub>**

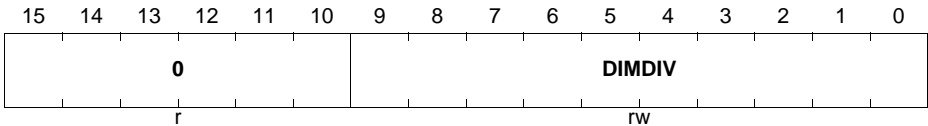
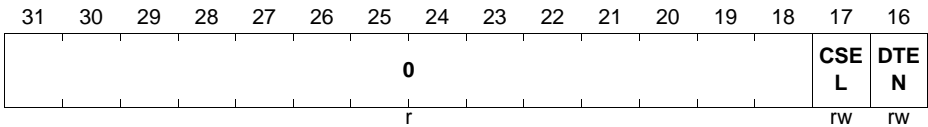


Field	Bits	Type	Description
DLEV	[11:0]	rh	Dimming Level
0	[31:12]	r	Reserved Read as 0; should be written with 0.

**Brightness and Color Control Unit (BCCU)**

**DTTz (z=0-2)**

**Dimming Transition Time**      **(0184<sub>H</sub> + z\*000C<sub>H</sub>)**      **Reset Value: 0000 0000<sub>H</sub>**



Field	Bits	Type	Description
<b>DIMDIV</b>	[9:0]	rw	<b>Dimming Clock Divider</b> BCCU_dclk is prescaled according to this value to generate the dimming clock; this value can be used to adjust the fade rate of the dimming engine. If this value is 0, then the dimming level will become the same as the target dimming level on shadow transfer and the dimming engine is bypassed.
<b>0</b>	[15:10]	r	<b>Reserved</b> Read as 0; should be written with 0.
<b>DTEN</b>	16	rw	<b>Dither Enable</b> 0 <sub>B</sub> No dithering 1 <sub>B</sub> Dithering is added to every dimming step if the dimming level is below 128; the coarse curve is used for the entire dimming range
<b>CSEL</b>	17	rw	<b>Curve Select</b> 0 <sub>B</sub> Coarse curve 1 <sub>B</sub> Fine curve If dithering is enabled (DTEN=1), this bit is ignored and the coarse curve is used
<b>0</b>	[31:18]	r	<b>Reserved</b> Read as 0; should be written with 0.

**Brightness and Color Control Unit (BCCU)**

## 20.9 Interconnects

BCCU0 is connected to the ports, the ERU, the analog comparator, the ADC, the NVIC, CCU4, the suspend signal and the kernel clock.

**Table 20-7 Pin Connections**

Input/Output	I/O	Connected To	Description
BCCU0_clk	I	PCLK	BCCU kernel clock
SUSPEND	I	CPU Halted	Suspend signal
BCCU0.IN0	I	ACMP1.OUT	Gating Input of channel 0
BCCU0.IN1	I	not connected (1)	Gating Input of channel 1
BCCU0.IN2	I	not connected (1)	Gating Input of channel 2
BCCU0.IN3	I	ACMP2.OUT	Gating Input of channel 3
BCCU0.IN4	I	not connected (1)	Gating Input of channel 4
BCCU0.IN5	I	ACMP0.OUT	Gating Input of channel 5
BCCU0.IN6	I	not connected (1)	Gating Input of channel 6
BCCU0.IN7	I	not connected (1)	Gating Input of channel 7
BCCU0.IN8	I	not connected (1)	Gating Input of channel 8
BCCU0.TRAPINA	I	P0.12	Trap input A
BCCU0.TRAPINB	I	P0.0	Trap input B
BCCU0.TRAPINC	I	not connected (0)	Trap input C
BCCU0.TRAPIND	I	not connected (0)	Trap input D
BCCU0.TRAPINE	I	ERU0.IOUT0	Trap input E
BCCU0.TRAPINF	I	ERU0.IOUT1	Trap input F
BCCU0.TRAPING	I	ERU0.IOUT2	Trap input G
BCCU0.TRAPINH	I	ERU0.IOUT3	Trap input H
BCCU0.TRAPINI	I	SCU.SR2	Trap input I
BCCU0.TRAPINJ	I	not connected (0)	Trap input J
BCCU0.TRAPINK	I	not connected (0)	Trap input K
BCCU0.TRAPINL	I	not connected (0)	Trap input L
BCCU0.TRAPINM	I	not connected (0)	Trap input M
BCCU0.TRAPINN	I	not connected (0)	Trap input N
BCCU0.TRAPINO	I	not connected (0)	Trap input O
BCCU0.TRAPINP	I	not connected (0)	Trap input P

**Brightness and Color Control Unit (BCCU)**

**Table 20-7 Pin Connections (cont'd)**

<b>Input/Output</b>	<b>I/O</b>	<b>Connected To</b>	<b>Description</b>
BCCU0.OUT0	O	P0.4 P1.0 P2.2.HW0 pull control	Output of channel 0
BCCU0.OUT1	O	P0.5 P1.5 P2.0.HW0 pull control P2.8.HW0 pull control	Output of channel 1
BCCU0.OUT2	O	P0.6 CCU40.MCI0 P1.0.HW0 pull control P2.6.HW0 pull control	Output of channel 2
BCCU0.OUT3	O	P0.7 CCU40.MCI1 P1.1.HW0 pull control	Output of channel 3
BCCU0.OUT4	O	P0.8 CCU40.MCI2 P1.2.HW0 pull control P2.10.HW0 pull control	Output of channel 4
BCCU0.OUT5	O	P0.9 CCU40.MCI3 P1.3.HW0 pull control P2.11.HW0 pull control	Output of channel 5
BCCU0.OUT6	O	P0.10 P0.12 P1.4.HW0 pull control P2.1.HW0 pull control	Output of channel 6
BCCU0.OUT7	O	P0.11 P0.14 P1.5.HW0 pull control P2.9.HW0 pull control	Output of channel 7
BCCU0.OUT8	O	P0.1 P0.15 P2.4.HW0 pull control P2.7.HW0 pull control	Output of channel 8

Service Request Connectivity



**Brightness and Color Control Unit (BCCU)**

**Table 20-7 Pin Connections (cont'd)**

<b>Input/Output</b>	<b>I/O</b>	<b>Connected To</b>	<b>Description</b>
BCCU0.SR0	O	NVIC	Service Request Node 0: Interrupt
BCCU0.TRIGOUT0	O	VADC0.BGREQTRF VADC0.G0REQTRF	ADC trigger signal 0
BCCU0.TRIGOUT1	O	VADC0.G1REQTRF	ADC trigger signal 1

# **General Purpose I/O Ports**

## 21 General Purpose I/O Ports (Ports)

The XMC1200 has 34 digital General Purpose Input/Output (GPIO) port lines which are connected to the on-chip peripheral units.

### 21.1 Overview

The Ports provide a generic and very flexible software and hardware interface for all standard digital I/Os. Each Port slice has individual interfaces for the operation as General Purpose I/O and it further provides the connectivity to the on-chip periphery and the control for the pad characteristics. [Table 21-1](#) gives an overview of the available PORTS and other pins in the different packages of the XMC1200:

**Table 21-1 Port/Pin Overview**

Port	TSSOP-38	TSSOP-28	TSSOP-16	Note
P0	16	12	8	
P1	6	4	-	High current bi-directional pad
P2	12	10	6	Analog/Digital input and bi-directional pad
Supply VDD, ADC / ORC Reference Voltage	1	1	1	VDD
Supply GND, ADC Reference Ground	1	1	1	VSS
I/O Port Supply	1	-	-	VDDP
I/O Port Ground	1	-	-	VSSP

#### 21.1.1 Features

This is a list of the main features of the Ports:

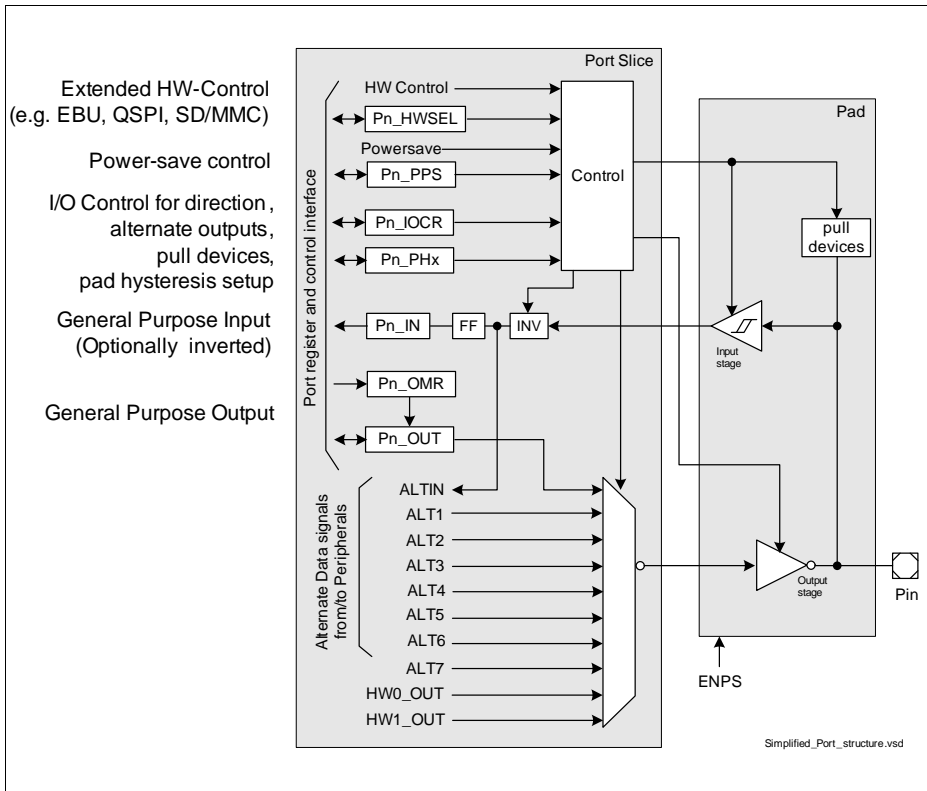
- same generic register interface for each port pin, [Chapter 21.8](#)
- simple and robust software access for general purpose I/O functionality, [Chapter 21.2](#)
- direct input connections to on-chip peripherals, [Chapter 21.2.1](#)
- dedicated hardware interface for BCCU, CCU, LEDTS and USIC with select option, [Chapter 21.3](#)
- defined power-up/power-fail behavior, [Chapter 21.6](#).
- up to seven alternate output paths from peripherals selectable, [Chapter 21.8.1](#)
- programmable open-drain or push-pull output driver stage, [Chapter 21.8.1](#)
- programmable weak pull-up and pull-down devices, [Chapter 21.8.1](#)

**General Purpose I/O Ports (Ports)**

- programmable input inverter, [Chapter 21.8.1](#)
- programmable pad hysteresis, [Chapter 21.8.2](#)
- disabling of digital input stage on shared analog inputs, [Chapter 21.8.3](#)
- separate set and clear output control to avoid read-modify-write operations, [Chapter 21.8.5](#)
- programmable power-save behavior in Deep-Sleep mode, [Chapter 21.8.7](#)
- Privileged Mode restricted access to configuration registers to avoid accidental modification

**21.1.2 Block Diagram**

Below is a figure with the generic structure of a digital port pin, split into the port slice with the control logic and the pad with the pull devices and the input and output stages, [Figure 21-1](#).



**Figure 21-1 General Structure of a digital Port Pin**

### 21.1.3 Definition of Terms

Some specific terms are used throughout this chapter:

- **Pin/Ball:** External connection of the device to the PCB.
- **Dedicated Pin:** A Pin with a dedicated function that is not under the control of the port logic (i.e. supply pins).
- **Port Pin:** A pin under the control of the port logic (P0.1).
- **Port:** A group of up to 16 Port Pins sharing the same generic register set (P0).
- **Port Slice:** The “sum” of register bits and control logic used to control a port pin.
- **Pad:** Analog component containing the output driver, pull devices and input Schmitt-Trigger. Also interfaces the internal logic operating on  $V_{DDC}$  to the pad supply domain  $V_{DDP}$ .
- **GPIO:** General Purpose Input/Output. A port pin with the input and/or output function controlled by the application software.
- **Alternate Function:** Direct connection of a port pin with an on-chip peripheral.

## 21.2 GPIO and Alternate Functions

The Ports can be operated as General Purpose Input/Output (GPIO) and with Alternate Functions of the on-chip periphery, configured by the Port Input/Output Control Register (Pn\_IOCR, [Chapter 21.8.1](#)). It selects between

- Direct or Inverted Input
  - with or without pull device
- Push-pull or Open-Drain Output driven by
  - Pn\_OUT (GPIO)
  - selected peripheral output connections.

As GPIO the port pin is controlled by the application software, reading the input value by the Port Input register Pn\_IN ([Chapter 21.8.6](#)) and/or defining the output value by the Output Modification Register Pn\_OMR ([Chapter 21.8.5](#)). Output modification by Pn\_OMR is preferred over the direct change of the output value with the Output register Pn\_OUT ([Chapter 21.8.4](#)), as Pn\_OMR allows the manipulation of individual port pins in a single access without “disturbing” other pins controlled by the same Pn\_OUT register. If an application uses a GPIO as a bi-directional I/O line, register Pn\_IOCR has to be written to switch between input and output functionality.

For the operation with Alternate Functions, the port pins are directly connected to input or output functions of the on-chip periphery. This allows the peripheral to directly evaluate the input value or drive the output value of the port pin without further application software interaction after the initial configuration. The connection of alternate functions is used for control and communication interfaces, like a PWM from a CAPCOM unit or a SPI communication of a USIC channel. A detailed connectivity list of the peripherals to the port pins is given in the [Port I/O Function Description](#) chapter. For specific functions, certain peripherals may also take direct control of “their” port pins, see [Hardware Controlled I/Os](#).

## 21.2.1 Input Operation

As an input, the actual voltage level at the port pin is translated into a logical 0<sub>B</sub> or 1<sub>B</sub> via a Schmitt-Trigger device within the pad. The resulting input value can be optionally inverted. As general purpose input, the signal is synchronized and can be read with the Input register (Pn\_IN, [Chapter 21.8.6](#)). Alternatively, the input can be connected to the multiple on-chip peripherals via the ALTIN signal. Where necessary, these peripherals have internal controls to select the appropriate port pin with an input multiplexer stage, and will take care of synchronization and further processing of the input signals. (See respective peripheral chapters for more details on the input selection and handling). With the Pn\_IOCR register ([Chapter 21.8.1](#)), it is also possible to activate an internal weak pull-up or pull-down device in the pad.

The input register Pn\_IN and ALTIN signal always represent the state of the input, independent whether the port pin is configured as input or output. This means that even if the port is in output mode, the level of the pin can be read by software via Pn\_IN and/or a peripheral can use the pin level as an input.

### Pad Hysteresis Control

The pad hysteresis can be configured according to the application needs via the Pad Hysteresis Control register (Pn\_PHCR, [Chapter 21.8.2](#)). Selecting the appropriate pad hysteresis allows optimized pad oscillation behaviour for touch-sensing applications.

## 21.2.2 Output Operation

In output mode, the output driver is activated and drives the value supplied through the multiplexer to the port pin. Switching between input and output mode is accomplished through the Pn\_IOCR register ([Chapter 21.8.1](#)), which

- enables or disables the output driver,
- selects between open-drain and push-pull mode,
- selects the general purpose or alternate function outputs.

The output multiplexer selects the signal source of the output with

- Pn\_IOCR
  - general purpose output (Pn\_OUT, [Chapter 21.8.4](#))
  - alternate peripheral functions, ALT1...ALT7
- hardware control, Pn\_HWSEL
  - HW0\_OUT
  - HW1\_OUT

*Note: It is recommended to complete the Port and peripheral configuration with respect to operating mode and initial values before the port pin is switched to output mode.*

The output function is exclusive, meaning that only one peripheral has control of the output path at any one time.

---

**General Purpose I/O Ports (Ports)**

Used as general purpose output, software can directly modify the content of Pn\_OUT to define the output value on the pin. A write operation to Pn\_OUT updates all port pins of that port (e.g. P0) that are configured as general purpose output. Updating just one or a selected few general purpose output pins via Pn\_OUT requires a masked read-modify-write operation to avoid disturbing pins that shall not be changed. Direct writes to Pn\_OUT will also affect Pn\_OUT bits configured for use with the Pin Power-save function, [Chapter 21.4](#).

Because of that, it is preferred to modify Pn\_OUT bits by the Output Modification Register Pn\_OMR ([Chapter 21.8.5](#)). The bits in Pn\_OMR allow to individually set, clear or toggle the bits in the Pn\_OUT register and only update the “addressed” Pn\_OUT bits. The data written by software into the output register Pn\_OUT can also be used as input data to an on-chip peripheral. This enables, for example, peripheral tests and simulation via software without external circuitry.

Output lines of on-chip peripherals can directly control the output value of the output driver if selected via ALT1 to ALT7 as well as HW0\_OUT and HW1\_OUT. After initialization, this allows the connected peripherals to directly drive complex control and communication patterns without further software interaction with the ports.

The actual logic level at the pin can be examined through reading Pn\_IN and compared against the applied output level (either applied by the output register Pn\_OUT, or via an alternate output function of a peripheral unit). This can be used to detect some electrical failures at the pin caused by external circuitry. In addition, software-supported arbitration schemes between different “masters” can be implemented in this way, using the open-drain configuration and an external wired-AND circuitry. Collisions on the external communication lines can be detected when a high level ( $1_B$ ) is output, but a low level ( $0_B$ ) is seen when reading the pin value via the input register Pn\_IN or directly by a peripheral (via ALTIN, for example a USIC channel in IIC mode).

There are two pad types in XMC1200 providing different drive strength:

- Standard pad
- High Current pad

The assignment of each port pin to one of these pad types is listed in the Package Pin Summary table. Further details about pad properties are summarized in the Data Sheet.

### **21.3 Hardware Controlled I/Os**

Some ports pins are overlaid with peripheral functions for which the connected peripheral needs direct hardware control, e.g. for the direction of a bi-directional data bus. There is a dedicated hardware control interface for these functions. As multiple peripherals need access to this interface, the Pn\_HWSEL register ([Chapter 21.8.8](#)) allows to select between the hardware “masters”.

Depending on the operating mode, the peripheral can take control of various functions:

- Pin direction, input or output, e.g. for bi-directional signals

**General Purpose I/O Ports (Ports)**

- Driver type, open-drain or push-pull
- Pull devices under peripheral control or under standard control via Pn\_IOCR

Some configurations remain under control by the standard configuration interface, the pad hysteresis by Pn\_PHCR and the direct or inverted input path by Pn\_IOCR.

Pn\_HWSEL.HWx just pre-assigns the hardware-control of the pin to a certain peripheral, but the peripheral itself decides when to take control over it. As long as the peripheral does not take control of a given pin via HWx\_EN, the configuration of this pin is still defined by the configuration registers and it is available as GPIO or for other alternate functions. This might be because the selected peripheral has controls to just activate a subset of its pins, or because the peripheral is not active at all.

This mechanism can also be used to prohibit the hardware control of certain pins to a peripheral, in case the application does not need the respective functionality and the peripheral has no controls to disable the hardware control selectively.

The default hardware input configuration and the pull devices are controlled by Pn\_IOCR.

If configured accordingly, the LEDTS module can also control the internal pull devices and change between push-pull and open-drain output drivers.

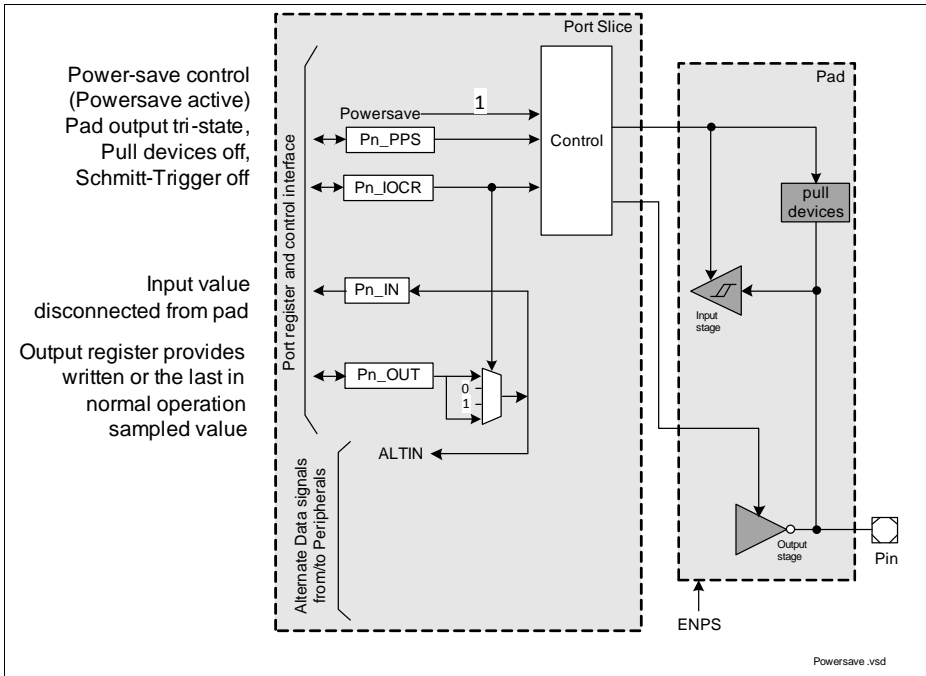
*Note: Do not enable the Pin Power Save function for pins configured for Hardware Control (Pn\_HWSEL.HWx != 00<sub>B</sub>). Doing so may result in an undefined behavior of the pin when the device enters the Deep Sleep state.*

## 21.4 Power Saving Mode Operation

In Deep-Sleep mode, the behavior of a pin depends on the setting of the Pin Power save register (Pn\_PPS, [Chapter 21.8.7](#)). Basically, each pin can be configured to react to the Power Save Mode Request or to ignore it. In case a pin is configured to react to a Power Save Mode Request, the output driver is switched to tri-state, the input Schmitt-Trigger and the pull devices are switched off (see [Figure 21-2](#)). The input signal to the on-chip peripherals is optionally driven statically high or low, software-defined by a value stored in Pn\_OUT or by the last input value sampled to the Pn\_OUT register during normal operation. The actual reaction is configured with the Pn\_IOCR register under power save conditions, see [Table 21-8](#).



**General Purpose I/O Ports (Ports)**



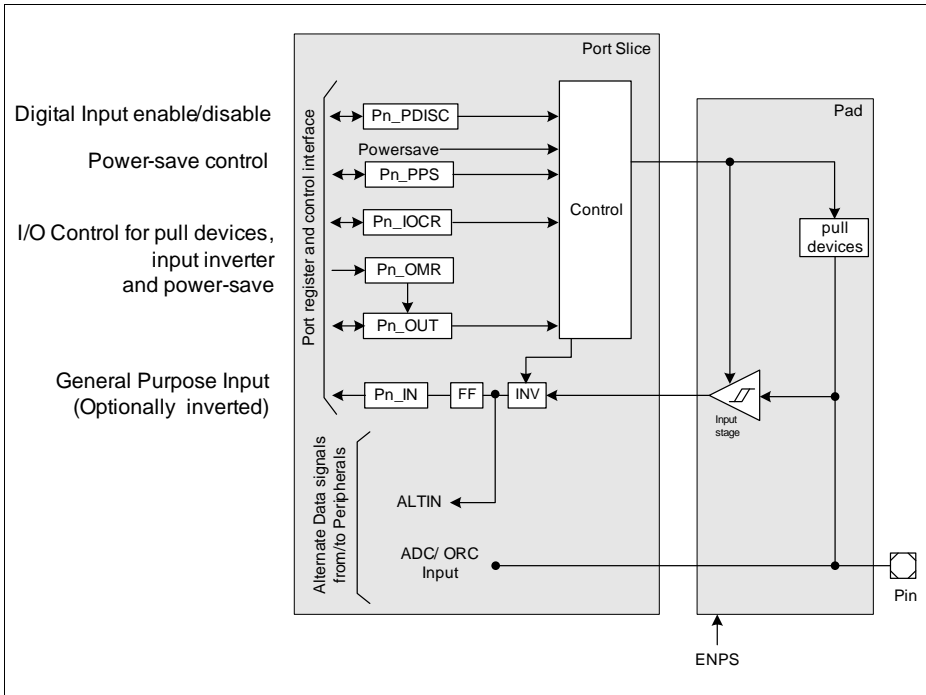
**Figure 21-2 Port Pin in Power Save State**

*Note: Do not enable the Pin Power Save function for pins configured for Hardware Control ( $Pn\_HWSEL.HWx \neq 00_B$ ). Doing so may result in an undefined behavior of the pin when the device enters the Deep Sleep state.*

## 21.5 Analog Ports

P2.2 - P2.9 is the analog and digital input port with a simplified port and pad structure, see [Figure 21-3](#). The analog pads have no output drivers and the digital input Schmitt-Trigger can be controlled by the  $Pn\_PDISC$  ([Chapter 21.8.3](#)) register. Accordingly, the port control interface is reduced in its functionality. The  $Pn\_IOCR$  register controls the pull devices, the optional input inversion and the input source in power-save mode. The  $Pn\_OUT$  has only its power-save functionality, as described in [Chapter 21.4](#).

**General Purpose I/O Ports (Ports)**



**Figure 21-3 Analog Port Structure**

**21.6 Power, Reset and Clock**

All digital I/O pads are held in a defined state, tristate, with output driver disabled and no pull devices active when one of the following occurs:

- During power-up, until  $V_{DDC}$  and  $V_{DDP}$  voltage levels are stable and within limits
- During power-fail, one or more voltage levels are outside the limits

Refer to the EVR section in the SCU chapter and Data Sheet for details on the power-up, supply monitoring and voltage limits.

All Port registers are reset with the System Reset (see Reset Control Unit chapter in the System Control Unit). The standard reset values are defined such that the port pins are configured as tri-state inputs, output driver disabled and no pull devices active. Exceptions from these standard values are related to special interfaces or the analog input channels.

All registers of the Ports are clocked with  $f_{MCLK}$ .

## 21.7 Initialization and System Dependencies

It is recommended to follow pre-defined routines for the initialization of the port pins.

### Input

When a peripheral shall use a port pin as input, the actual pin levels may immediately trigger an unexpected peripheral event (e.g. clock edge at SPI). This can be avoided by forcing the "passive" level via pull-up/down programming.

The following steps are required to configure a port pin as an input:

- Pn\_IOCR  
input configuration with pull device and/or power-save mode configuration
- Pn\_PHCR  
pad hysteresis configuration (if applicable)
- Hardware Control (if applicable)
  - Pn\_HWSEL  
switch hardware control to peripheral
- Pin Power Save (if applicable)
  - Pn\_OMR/Pn\_OUT  
default value in power save mode (if applicable)
  - Pn\_PPS  
enable power save control

### Output

When a port pin is configured as output for an on-chip peripheral, it is important that the peripheral is configured before the port switches the control to the peripheral in order to avoid spikes on the output.

The following steps are required to configure a port pin as an output:

- Pn\_OMR/Pn\_OUT  
Initial output value (as general purpose output)
- GPIO or Alternate Output
  - Pn\_IOCR  
Output multiplexer select  
Push-pull or open-drain output driver mode  
Activates the output driver!
- Hardware Control
  - Pn\_IOCR  
depending on the hardware function Pn\_IOCR can enable the internal pull devices
  - Pn\_HWSEL  
Switch hardware control to peripheral

### **Transitions**

If a port pin is used for different functions that require a reconfiguration of the port registers, it is recommended to do this transition via an intermediate “neutral” tri-state input configuration.

- **Pn\_HWSEL**  
disable hardware selection; can be omitted if no hardware control is used on the port pin
- **Pn\_PPS**  
disable power save mode control of the pin; can be omitted if no power save configuration is used on the port pin
- **Pn\_IOC**  
tri-state input and no pull device active

## 21.8 Registers

### Registers Overview

The absolute register address is calculated by adding:  
Module Base Address + Offset Address

**Table 21-2 Registers Address Space**

Module	Base Address	End Address	Note
P0	4004 0000 <sub>H</sub>	4004 00FF <sub>H</sub>	
P1	4004 0100 <sub>H</sub>	4004 01FF <sub>H</sub>	High current bi-directional pad
P2	4004 0200 <sub>H</sub>	4004 02FF <sub>H</sub>	Analog/Digital input and bi-directional pad

**Table 21-3 Register Overview**

Short Name	Description	Offset Addr.	Access Mode		Description See
			Read	Write	
Pn_OUT	Port n Output Register	0000 <sub>H</sub>	U, PV	U, PV	<a href="#">Page 21-28</a>
Pn_OMR	Port n Output Modification Register	0004 <sub>H</sub>	U, PV	U, PV	<a href="#">Page 21-31</a>
–	Reserved	0008 <sub>H</sub> -000C <sub>H</sub>	BE	BE	–
Pn_IOCR0	Port n Input/Output Control Register 0	0010 <sub>H</sub>	U, PV	PV	<a href="#">Page 21-14</a>
Pn_IOCR4	Port n Input/Output Control Register 4	0014 <sub>H</sub>	U, PV	PV	<a href="#">Page 21-15</a>
Pn_IOCR8	Port n Input/Output Control Register 8	0018 <sub>H</sub>	U, PV	PV	<a href="#">Page 21-16</a>
Pn_IOCR12	Port n Input/Output Control Register 12	001C <sub>H</sub>	U, PV	PV	<a href="#">Page 21-16</a>
–	Reserved	0020 <sub>H</sub>	BE	BE	–
Pn_IN	Port n Input Register	0024 <sub>H</sub>	U, PV	R	<a href="#">Page 21-34</a>
–	Reserved	0028 <sub>H</sub> -003C <sub>H</sub>	BE	BE	–

**General Purpose I/O Ports (Ports)**

**Table 21-3 Register Overview (cont'd)**

Short Name	Description	Offset Addr.	Access Mode		Description See
			Read	Write	
Pn_PHCR0	Port n Pad Hysteresis Control Register 0	0040 <sub>H</sub>	U, PV	PV	<a href="#">Page 21-20</a>
Pn_PHCR1	Port n Pad Hysteresis Control Register 1	0044 <sub>H</sub>	U, PV	PV	<a href="#">Page 21-21</a>
–	Reserved	0048 <sub>H</sub> - 005C <sub>H</sub>	BE	BE	–
P0_PDISC P1_PDISC	Port n Pin Function Decision Control Register (non-ADC ports)	0060 <sub>H</sub>	U, PV	BE	<a href="#">Page 21-23</a>
P2_PDISC	Port n Pin Function Decision Control Register (ADC ports)	0060 <sub>H</sub>	U, PV	PV	<a href="#">Page 21-24</a>
–	Reserved	0064 <sub>H</sub> - 006C <sub>H</sub>	BE	BE	–
Pn_PPS	Port n Pin Power Save Register	0070 <sub>H</sub>	U, PV	PV	<a href="#">Page 21-36</a>
Pn_HWSEL	Port n Hardware Select Register	0074 <sub>H</sub>	U, PV	PV	<a href="#">Page 21-39</a>
–	Reserved	0078 <sub>H</sub> - 00FC <sub>H</sub>	BE	BE	–

**Table 21-4 Registers Access Rights and Reset Classes**

Register Short Name	Access Rights		Reset Class
	Read	Write	
Pn_IN	U, PV	R	System Reset
Pn_OUT		U, PV	
Pn_OMR			
Pn_IOCR0		PV	
Pn_IOCR4			
Pn_IOCR8			
Pn_IOCR12			
Pn_PDISC (ADC ports)			
Pn_PH0			
Pn_PH1			
Pn_PPS			
Pn_PDISC (non-ADC ports)		BE	

### 21.8.1 Port Input/Output Control Registers

The port input/output control registers select the digital output and input driver functionality and characteristics of a GPIO port pin. Port direction (input or output), pull-up or pull-down devices for inputs, and push-pull or open-drain functionality for outputs can be selected by the corresponding bit fields PCx (x = 0-15). Each 32-bit wide port input/output control register controls four GPIO port lines:

- Register Pn\_IOCR0 controls the Pn.[3:0] port lines
- Register Pn\_IOCR4 controls the Pn.[7:4] port lines
- Register Pn\_IOCR8 controls the Pn.[11:8] port lines
- Register Pn\_IOCR12 controls the Pn.[15:12] port lines

The diagrams below show the register layouts of the port input/output control registers with the PCx bit fields. One PCx bit field controls exactly one port line Pn.x.

#### Pn\_IOCR0 (n=0-1)

##### Port n Input/Output Control Register 0

(4004 0010<sub>H</sub> + n\*100<sub>H</sub>)

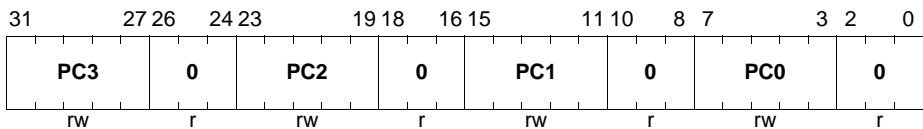
Reset Value: 0000 0000<sub>H</sub>

#### P2\_IOCR0

##### Port 2 Input/Output Control Register 0

(0010<sub>H</sub>)

Reset Value: 0000 0000<sub>H</sub>



Field	Bits	Type	Description
<b>PC0,</b> <b>PC1,</b> <b>PC2,</b> <b>PC3</b>	[7:3], [15:11], [23:19], [31:27]	rw	<b>Port Control for Port n Pin 0 to 3</b> This bit field determines the Port n line x functionality (x = 0-3) according to the coding table (see <a href="#">Table 21-5</a> ).
<b>0</b>	[2:0], [10:8], [18:16], [26:24]	r	<b>Reserved</b> Read as 0; should be written with 0.



**General Purpose I/O Ports (Ports)**

**P0\_IOCR4**

**Port 0 Input/Output Control Register 4**

(0014<sub>H</sub>)

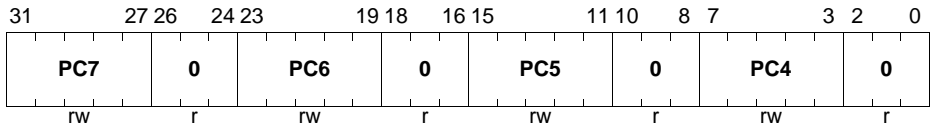
**Reset Value: 0000 0000<sub>H</sub>**

**P2\_IOCR4**

**Port 2 Input/Output Control Register 4**

(0014<sub>H</sub>)

**Reset Value: 0000 0000<sub>H</sub>**



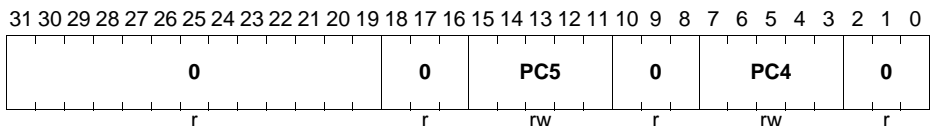
Field	Bits	Type	Description
<b>PC4, PC5, PC6, PC7</b>	[7:3], [15:11], [23:19], [31:27]	rw	<b>Port Control for Port n Pin 4 to 7</b> This bit field determines the Port n line x functionality (x = 4-7) according to the coding table (see <a href="#">Table 21-5</a> ).
<b>0</b>	[2:0], [10:8], [18:16], [26:24]	r	<b>Reserved</b> Read as 0; should be written with 0.

**P1\_IOCR4**

**Port 1 Input/Output Control Register 4**

(0014<sub>H</sub>)

**Reset Value: 0000 0000<sub>H</sub>**



Field	Bits	Type	Description
<b>PC4, PC5</b>	[7:3], [15:11]	rw	<b>Port Control for Port n Pin 4 to 5</b> This bit field determines the Port n line x functionality (x = 4-5) according to the coding table (see <a href="#">Table 21-5</a> ).

**General Purpose I/O Ports (Ports)**

Field	Bits	Type	Description
<b>0</b>	[2:0], [10:8], [18:16], [31:19]	r	<b>Reserved</b> Read as 0; should be written with 0.

**P0\_IOCR8**

**Port 0 Input/Output Control Register 8**

(0018<sub>H</sub>)

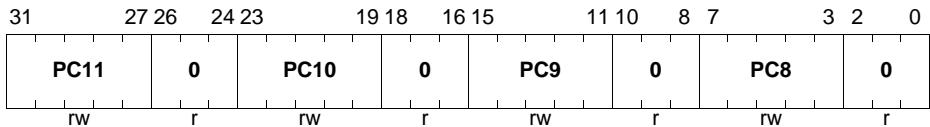
**Reset Value: 0000 0000<sub>H</sub><sup>1)</sup>**

**P2\_IOCR8**

**Port 2 Input/Output Control Register 8**

(0018<sub>H</sub>)

**Reset Value: 0000 0000<sub>H</sub>**



1) Upon reset, the value of PC8 (P0.8) is 00000<sub>B</sub>. The Startup Software (SSW) will change the PC8 value to input pull-up device active, 00010<sub>B</sub>. Refer to the Startup chapter for more information.

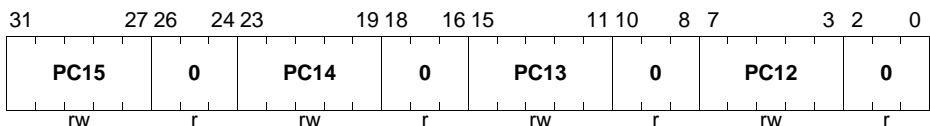
Field	Bits	Type	Description
<b>PC8, PC9, PC10, PC11</b>	[7:3], [15:11], [23:19], [31:27]	rw	<b>Port Control for Port n Pin 8 to 11</b> This bit field determines the Port n line x functionality (x = 8-11) according to the coding table (see <a href="#">Table 21-5</a> ).
<b>0</b>	[2:0], [10:8], [18:16], [26:24]	r	<b>Reserved</b> Read as 0; should be written with 0.

**P0\_IOCR12**

**Port 0 Input/Output Control Register 12**

(001C<sub>H</sub>)

**Reset Value: 0000 0000<sub>H</sub>**



**General Purpose I/O Ports (Ports)**

Field	Bits	Type	Description
<b>PC12,</b> <b>PC13,</b> <b>PC14,</b> <b>PC15</b>	[7:3], [15:11], [23:19], [31:27]	rw	<b>Port Control for Port n Pin 12 to 15</b> This bit field determines the Port n line x functionality (x = 12-15) according to the coding table (see <a href="#">Table 21-5</a> ).
<b>0</b>	[2:0], [10:8], [18:16], [26:24]	r	<b>Reserved</b> Read as 0; should be written with 0.

Depending on the GPIO port functionality (number of GPIO lines of a port), not all of the port input/output control registers are implemented.

The structure with one control bit field for each port pin located in different register bytes offers the possibility to configure the port pin functionality of a single pin with byte-oriented accesses without accessing the other PCx bit fields.

**Port Control Coding**

[Table 21-5](#) describes the coding of the PCx bit fields that determine the port line functionality.

The Pn\_IOCRy PCx bit field is also used to control the pin behavior in Deep-Sleep mode if the Pin Power Save option is enabled, see [Chapter 21.8.7](#).

**Table 21-5 Standard PCx Coding<sup>1)</sup>**

PCx[4:0]	I/O	Output Characteristics	Selected Pull-up / Pull-down / Selected Output Function
0X000 <sub>B</sub>	Direct Input	–	No internal pull device active
0X001 <sub>B</sub>			Internal pull-down device active
0X010 <sub>B</sub>			Internal pull-up device active
0X011 <sub>B</sub>			No internal pull device active; Pn_OUTx continuously samples the input value
0X100 <sub>B</sub>	Inverted Input	–	No internal pull device active
0X101 <sub>B</sub>			Internal pull-down device active
0X110 <sub>B</sub>			Internal pull-up device active
0X111 <sub>B</sub>			No internal pull device active; Pn_OUTx continuously samples the input value

**General Purpose I/O Ports (Ports)**

**Table 21-5 Standard PCx Coding<sup>1)</sup> (cont'd)**

PCx[4:0]	I/O	Output Characteristics	Selected Pull-up / Pull-down / Selected Output Function
10000 <sub>B</sub>	Output (Direct Input)	Push-pull	General-purpose output
10001 <sub>B</sub>			Alternate output function 1
10010 <sub>B</sub>			Alternate output function 2
10011 <sub>B</sub>			Alternate output function 3
10100 <sub>B</sub>			Alternate output function 4
10101 <sub>B</sub>			Alternate output function 5
10110 <sub>B</sub>			Alternate output function 6
10111 <sub>B</sub>			Alternate output function 7
11000 <sub>B</sub>		Open-drain	General-purpose output
11001 <sub>B</sub>			Alternate output function 1
11010 <sub>B</sub>			Alternate output function 2
11011 <sub>B</sub>			Alternate output function 3
11100 <sub>B</sub>			Alternate output function 4
11101 <sub>B</sub>			Alternate output function 5
11110 <sub>B</sub>			Alternate output function 6
11111 <sub>B</sub>			Alternate output function 7

1) For the analog and digital input port P2.2 - P2.9, the combinations with PCx[4]=1<sub>B</sub> is reserved.

### 21.8.2 Pad Hysteresis Control Register

The pad structure of the XMC1200 GPIO lines offers the possibility to select the pad hysteresis. These two parameters are controlled by the bit fields in the pad hysteresis control registers Pn\_PHCR0/1, independently from input/output and pull-up/pull-down control functionality as programmed in the Pn\_IOCRR register. Pn\_PHCR0 and Pn\_PHCR1 registers are assigned to each port.

The 1-bit pad hysteresis selection bit field PHx in the pad hysteresis control registers Pn\_PHCR make it possible to select the port line functionality as shown in [Table 21-6](#). Note that the pad hysteresis control registers are specific for each port.

**Table 21-6 Pad Hysteresis Selection**

PHx	Functionality
0	Standard hysteresis
1	Large hysteresis

**General Purpose I/O Ports (Ports)**

*Note: Refer to Input/Output Characteristics table in the XMC1200 Data Sheet for hysteresis parameter values.*

**Pad Hysteresis Control Registers**

This is the general description of the PHCR registers. Each port contains its own specific PHCR registers, described additionally at each port, that can contain between one and eight PHx fields for PHCR0 and PHCR1 registers, respectively. Each field controls 1 pin. For coding of PHx, see [Page 21-18](#).

**P0\_PHCR0**

**Port 0 Pad Hysteresis Control Register 0**

(0040<sub>H</sub>)

**Reset Value: 0000 0000<sub>H</sub>**

**P2\_PHCR0**

**Port 2 Pad Hysteresis Control Register 0**

(0040<sub>H</sub>)

**Reset Value: 0000 0000<sub>H</sub>**

31	30	29	28	27	26	25	24	23	22	21	20	19	18	17	16
0	PH7	0	0	0	PH6	0	0	0	PH5	0	0	0	PH4	0	0
r	r/w	r	r	r	r/w	r	r	r	r/w	r	r	r	r/w	r	r
15	14	13	12	11	10	9	8	7	6	5	4	3	2	1	0
0	PH3	0	0	0	PH2	0	0	0	PH1	0	0	0	PH0	0	0
r	r/w	r	r	r	r/w	r	r	r	r/w	r	r	r	r/w	r	r

Field	Bits	Type	Description
PH0	2	r/w	Pad Hysteresis for Pn.0
PH1	6	r/w	Pad Hysteresis for Pn.1
PH2	10	r/w	Pad Hysteresis for Pn.2
PH3	14	r/w	Pad Hysteresis for Pn.3
PH4	18	r/w	Pad Hysteresis for Pn.4
PH5	22	r/w	Pad Hysteresis for Pn.5
PH6	26	r/w	Pad Hysteresis for Pn.6
PH7	30	r/w	Pad Hysteresis for Pn.7

**General Purpose I/O Ports (Ports)**

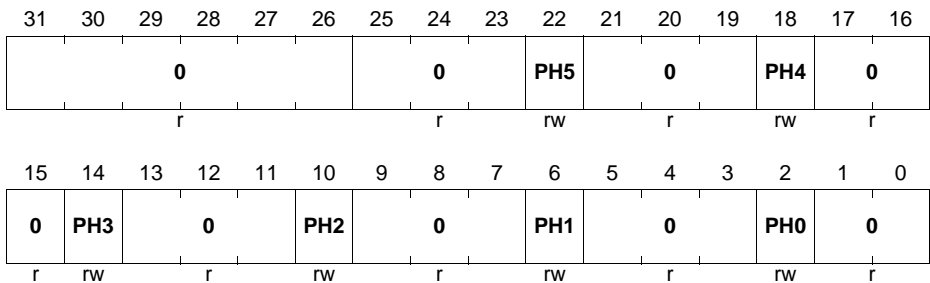
Field	Bits	Type	Description
<b>0</b>	[1:0], [5:3], [9:7], [13:11], [17:15], [21:19], [25:23], [29:27], 31	r	<b>Reserved</b> Read as 0; should be written with 0.

**P1\_PHCR0**

**Port 1 Pad Hysteresis Control Register 0**

(0040<sub>H</sub>)

Reset Value: 0000 0000<sub>H</sub>



Field	Bits	Type	Description
<b>PH0</b>	2	rw	<b>Pad Hysteresis for P1.0</b>
<b>PH1</b>	6	rw	<b>Pad Hysteresis for P1.1</b>
<b>PH2</b>	10	rw	<b>Pad Hysteresis for P1.2</b>
<b>PH3</b>	14	rw	<b>Pad Hysteresis for P1.3</b>
<b>PH4</b>	18	rw	<b>Pad Hysteresis for P1.4</b>
<b>PH5</b>	22	rw	<b>Pad Hysteresis for P1.5</b>

**General Purpose I/O Ports (Ports)**

Field	Bits	Type	Description
<b>0</b>	[1:0], [5:3], [9:7], [13:11], [17:15], [21:19], [25:23], [31:26]	r	<b>Reserved</b> Read as 0; should be written with 0.

**P0\_PHCR1**

**Port 0 Pad Hysteresis Control Register 1**

(0044<sub>H</sub>)

Reset Value: 0000 0000<sub>H</sub>

31	30	29	28	27	26	25	24	23	22	21	20	19	18	17	16
<b>0</b>	<b>PH1 5</b>		<b>0</b>		<b>PH1 4</b>		<b>0</b>		<b>PH1 3</b>		<b>0</b>		<b>PH1 2</b>		<b>0</b>
r	rw		r		rw		r		rw		r		rw		r
15	14	13	12	11	10	9	8	7	6	5	4	3	2	1	0
<b>0</b>	<b>PH1 1</b>		<b>0</b>		<b>PH1 0</b>		<b>0</b>		<b>PH9</b>		<b>0</b>		<b>PH8</b>		<b>0</b>
r	rw		r		rw		r		rw		r		rw		r

Field	Bits	Type	Description
<b>PH8</b>	2	rw	<b>Pad Hysteresis for P0.8</b>
<b>PH9</b>	6	rw	<b>Pad Hysteresis for P0.9</b>
<b>PH10</b>	10	rw	<b>Pad Hysteresis for P0.10</b>
<b>PH11</b>	14	rw	<b>Pad Hysteresis for P0.11</b>
<b>PH12</b>	18	rw	<b>Pad Hysteresis for P0.12</b>
<b>PH13</b>	22	rw	<b>Pad Hysteresis for P0.13</b>
<b>PH14</b>	26	rw	<b>Pad Hysteresis for P0.14</b>
<b>PH15</b>	30	rw	<b>Pad Hysteresis for P0.15</b>

**General Purpose I/O Ports (Ports)**

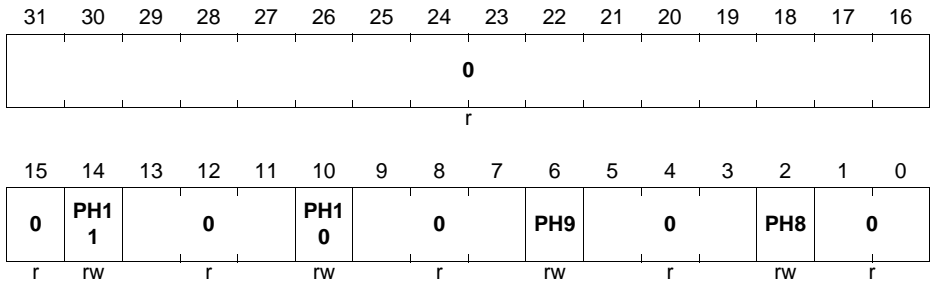
Field	Bits	Type	Description
<b>0</b>	[1:0], [5:3], [9:7], [13:11], [17:15], [21:19], [25:23], [29:27], 31	r	<b>Reserved</b> Read as 0; should be written with 0.

**P2\_PHCR1**

**Port 2 Pad Hysteresis Control Register 1**

(0044<sub>H</sub>)

Reset Value: 0000 0000<sub>H</sub>



Field	Bits	Type	Description
<b>PH8</b>	2	rW	<b>Pad Hysteresis for P2.8</b>
<b>PH9</b>	6	rW	<b>Pad Hysteresis for P2.9</b>
<b>PH10</b>	10	rW	<b>Pad Hysteresis for P2.10</b>
<b>PH11</b>	14	rW	<b>Pad Hysteresis for P2.11</b>
<b>0</b>	[1:0], [5:3], [9:7], [13:11], [31:15]	r	<b>Reserved</b> Read as 0; should be written with 0.



### 21.8.3 Pin Function Decision Control Register

#### Pin Function Decision Control Register

The primary use for this register is to disable/enable the digital pad structure in shared analog and digital ports, see the dedicated description for [P2\\_PDISC](#).

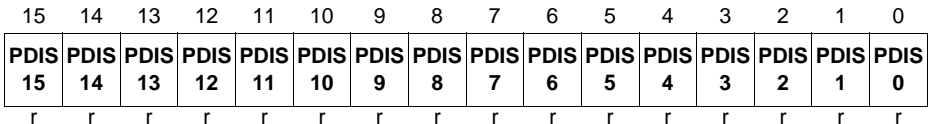
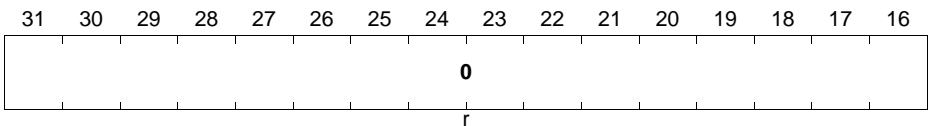
For “normal” digital I/O ports (P0-P1) this register is read-only and the read value corresponds to the available pins in the given package.

#### P0\_PDISC

#### Port 0 Pin Function Decision Control Register

(0060<sub>H</sub>)

Reset Value: 0000 XXXX<sub>H</sub><sup>1)</sup>



1) The reset value is package dependent.

Field	Bits	Type	Description
<b>PDISx</b> (x = 0-15)	x	r	<b>Pad Disable for Port 0 Pin x</b> 0 <sub>B</sub> Pad P0.x is enabled. 1 <sub>B</sub> Pad P0.x is disabled.
<b>0</b>	[31:16]	r	<b>Reserved</b> Read as 0; should be written with 0.

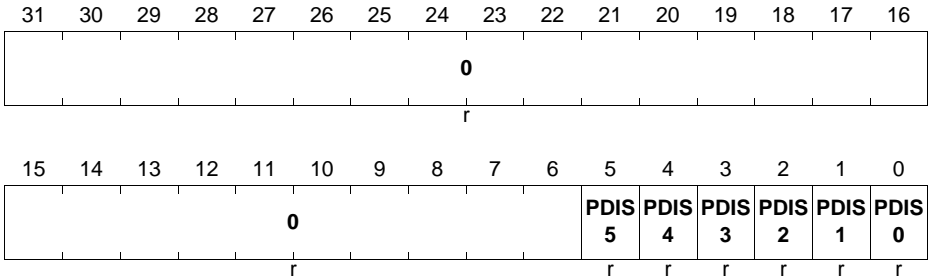
**General Purpose I/O Ports (Ports)**

**P1\_PDISC**

**Port 1 Pin Function Decision Control Register**

**(0060<sub>H</sub>)**

**Reset Value: 0000 00XX<sub>H</sub><sup>1)</sup>**



1) The reset value is package dependent.

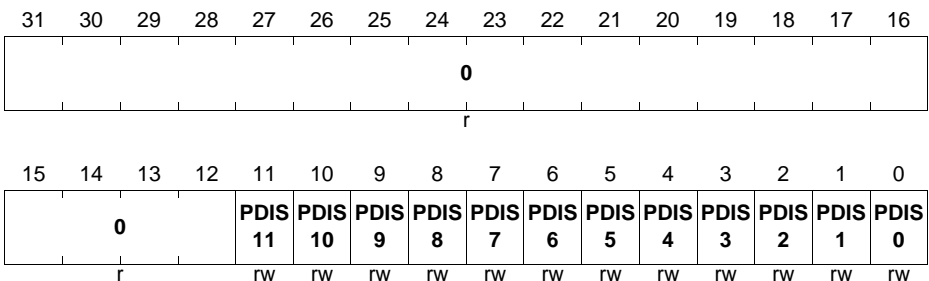
Field	Bits	Type	Description
<b>PDIS<sub>x</sub></b> <b>(x = 0-5)</b>	x	r	<b>Pad Disable for Port 1 Pin x</b> 0 <sub>B</sub> Pad P1.x is enabled. 1 <sub>B</sub> Pad P1.x is disabled.
<b>0</b>	[31:6]	r	<b>Reserved</b> Read as 0; should be written with 0.

**P2\_PDISC**

**Port 2 Pin Function Decision Control Register**

**(0060<sub>H</sub>)**

**Reset Value: 0000 0XXX<sub>H</sub><sup>1)</sup>**



1) The reset value is package dependent.

**General Purpose I/O Ports (Ports)**

<b>Field</b>	<b>Bits</b>	<b>Type</b>	<b>Description</b>
<b>PDIS0</b>	0	rw	<p><b>Pad Disable for Port 2 Pin 0</b></p> <p>This bit disables or enables the digital pad function. The disabled (default) state of the pad selects the ADC analog input. Upon enabling, the functionality switches to the digital input/output.</p> <p>0<sub>B</sub> Pad is enabled, digital input/output selected. 1<sub>B</sub> Pad is disabled, ADC S&amp;H 0 analog input 5 selected. (default)</p>
<b>PDIS1</b>	1	rw	<p><b>Pad Disable for Port 2 Pin 1</b></p> <p>This bit disables or enables the digital pad function. The disabled (default) state of the pad selects the ADC analog input. Upon enabling, the functionality switches to the digital input/output.</p> <p>0<sub>B</sub> Pad is enabled, digital input/output selected. 1<sub>B</sub> Pad is disabled, ADC S&amp;H 0 analog input 6 selected. (default)</p>
<b>PDIS2</b>	2	rw	<p><b>Pad Disable for Port 2 Pin 2</b></p> <p>This bit disables or enables the digital pad function. The disabled (default) state of the pad selects the ADC analog input. Upon enabling, the functionality switches to the digital input.</p> <p>0<sub>B</sub> Pad is enabled, digital input selected. 1<sub>B</sub> Pad is disabled, ADC S&amp;H 0 analog input 7 selected. (default)</p>
<b>PDIS3</b>	3	rw	<p><b>Pad Disable for Port 2 Pin 3</b></p> <p>This bit disables or enables the digital pad function. The disabled (default) state of the pad selects the ADC analog input. Upon enabling, the functionality switches to the digital input.</p> <p>0<sub>B</sub> Pad is enabled, digital input selected. 1<sub>B</sub> Pad is disabled, ADC S&amp;H 1 analog input 5 selected. (default)</p>

**General Purpose I/O Ports (Ports)**

Field	Bits	Type	Description
<b>PDIS4</b>	4	rw	<p><b>Pad Disable for Port 2 Pin 4</b></p> <p>This bit disables or enables the digital pad function. The disabled (default) state of the pad selects the ADC analog input. Upon enabling, the functionality switches to the digital input.</p> <p>0<sub>B</sub> Pad is enabled, digital input selected. 1<sub>B</sub> Pad is disabled, ADC S&amp;H 1 analog input 6 selected. (default)</p>
<b>PDIS5</b>	5	rw	<p><b>Pad Disable for Port 2 Pin 5</b></p> <p>This bit disables or enables the digital pad function. The disabled (default) state of the pad selects the ADC analog input. Upon enabling, the functionality switches to the digital input.</p> <p>0<sub>B</sub> Pad is enabled, digital input selected. 1<sub>B</sub> Pad is disabled, ADC S&amp;H 1 analog input 7 selected. (default)</p>
<b>PDIS6</b>	6	rw	<p><b>Pad Disable for Port 2 Pin 6</b></p> <p>This bit disables or enables the digital pad function. The disabled (default) state of the pad selects the ADC analog input. Upon enabling, the functionality switches to the digital input.</p> <p>0<sub>B</sub> Pad is enabled, digital input selected. 1<sub>B</sub> Pad is disabled, ADC S&amp;H 0 analog input 0 selected. (default)</p>
<b>PDIS7</b>	7	rw	<p><b>Pad Disable for Port 2 Pin 7</b></p> <p>This bit disables or enables the digital pad function. The disabled (default) state of the pad selects the ADC analog input. Upon enabling, the functionality switches to the digital input.</p> <p>0<sub>B</sub> Pad is enabled, digital input selected. 1<sub>B</sub> Pad is disabled, ADC S&amp;H 1 analog input 1 selected. (default)</p>
<b>PDIS8</b>	8	rw	<p><b>Pad Disable for Port 2 Pin 8</b></p> <p>This bit disables or enables the digital pad function. The disabled (default) state of the pad selects the ADC analog input. Upon enabling, the functionality switches to the digital input.</p> <p>0<sub>B</sub> Pad is enabled, digital input selected. 1<sub>B</sub> Pad is disabled, ADC S&amp;H 0 analog input 1 and ADC S&amp;H 1 analog input 0 selected. (default)</p>

**General Purpose I/O Ports (Ports)**

Field	Bits	Type	Description
<b>PDIS9</b>	9	rw	<p><b>Pad Disable for Port 2 Pin 9</b></p> <p>This bit disables or enables the digital pad function. The disabled (default) state of the pad selects the ADC analog input. Upon enabling, the functionality switches to the digital input.</p> <p>0<sub>B</sub> Pad is enabled, digital input selected. 1<sub>B</sub> Pad is disabled, ADC S&amp;H 0 analog input 2 and ADC S&amp;H 1 analog input 4 selected. (default)</p>
<b>PDIS10</b>	10	rw	<p><b>Pad Disable for Port 2 Pin 10</b></p> <p>This bit disables or enables the digital pad function. The disabled (default) state of the pad selects the ADC analog input. Upon enabling, the functionality switches to the digital input/output.</p> <p>0<sub>B</sub> Pad is enabled, digital input/output selected. 1<sub>B</sub> Pad is disabled, ADC S&amp;H 0 analog input 3 and ADC S&amp;H 1 analog input 2 selected. (default)</p>
<b>PDIS11</b>	11	rw	<p><b>Pad Disable for Port 2 Pin 11</b></p> <p>This bit disables or enables the digital pad function. The disabled (default) state of the pad selects the ADC analog input. Upon enabling, the functionality switches to the digital input/output.</p> <p>0<sub>B</sub> Pad is enabled, digital input/output selected. 1<sub>B</sub> Pad is disabled, ADC S&amp;H 0 analog input 4 and ADC S&amp;H 1 analog input 3 selected. (default)</p>
<b>0</b>	[31:12]	r	<p><b>Reserved</b></p> <p>Read as 0; should be written with 0.</p>

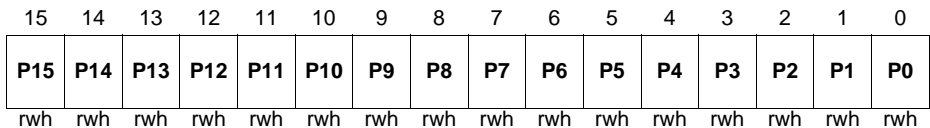
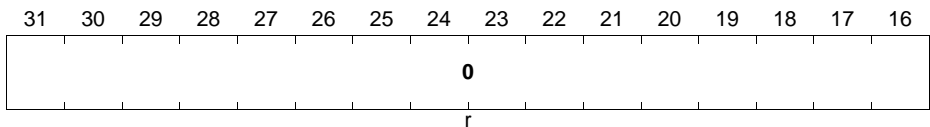
### 21.8.4 Port Output Register

The port output register determines the value of a GPIO pin when it is selected by Pn\_IOCRx as output. Writing a 0 to a Pn\_OUT.Px (x = 0-15) bit position delivers a low level at the corresponding output pin. A high level is output when the corresponding bit is written with a 1. Note that the bits of Pn\_OUT.Px can be individually set/reset by writing appropriate values into the port output modification register Pn\_OMR, avoiding read-modify-write operations on the Pn\_OUT, which might affect other pins of the port.

The Pn\_OUT is also used to store/drive a defined value for the input in Deep-Sleep mode. For details on this, see the [Port Pin Power Save Register](#). That is also the only use of the Pn\_OUT register in the analog and digital input port P2.2 - P2.9.

#### P0\_OUT

**Port 0 Output Register** (0000<sub>H</sub>) **Reset Value: 0000 0000<sub>H</sub>**



Field	Bits	Type	Description
<b>Px</b> <b>(x = 0-15)</b>	x	rwh	<b>Port 0 Output Bit x</b> This bit determines the level at the output pin P0.x if the output is selected as GPIO output. 0 <sub>B</sub> The output level of P0.x is 0. 1 <sub>B</sub> The output level of P0.x is 1. P0.x can also be set/reset by control bits of the P0_OMR register.
<b>0</b>	[31:16]	r	<b>Reserved</b> Read as 0; should be written with 0.

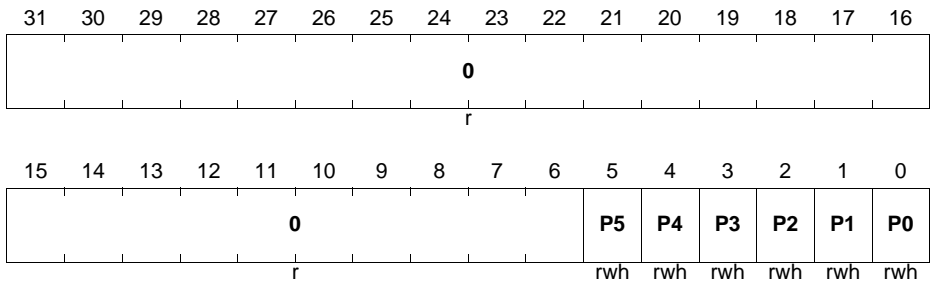
**General Purpose I/O Ports (Ports)**

**P1\_OUT**

**Port 1 Output Register**

**(0000<sub>H</sub>)**

**Reset Value: 0000 0000<sub>H</sub>**



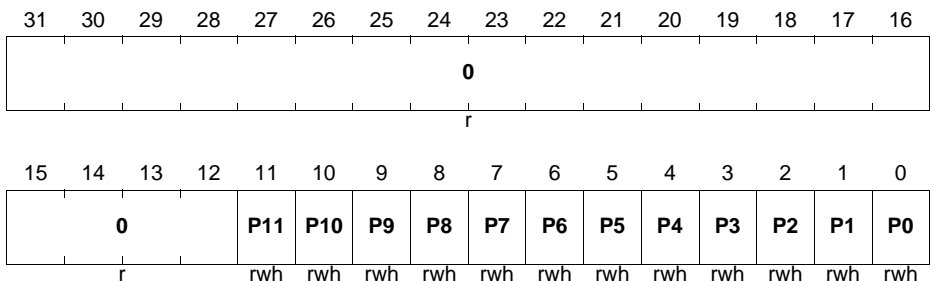
Field	Bits	Type	Description
<b>Px</b> (x = 0-5)	x	rwh	<b>Port 1 Output Bit x</b> This bit determines the level at the output pin P1.x if the output is selected as GPIO output. 0 <sub>B</sub> The output level of P1.x is 0. 1 <sub>B</sub> The output level of P1.x is 1. P1.x can also be set/reset by control bits of the P1_OMR register.
<b>0</b>	[31:6]	r	<b>Reserved</b> Read as 0; should be written with 0.

**P2\_OUT**

**Port 2 Output Register**

**(0000<sub>H</sub>)**

**Reset Value: 0000 0000<sub>H</sub>**



**General Purpose I/O Ports (Ports)**

<b>Field</b>	<b>Bits</b>	<b>Type</b>	<b>Description</b>
<b>Px</b> <b>(x = 0-11)</b>	x	rwh	<b>Port 2 Output Bit x</b> This bit determines the level at the output pin P2.x if the output is selected as GPIO output. 0 <sub>B</sub> The output level of P2.x is 0. 1 <sub>B</sub> The output level of P2.x is 1. P2.x can also be set/reset by control bits of the P2_OMR register.
<b>0</b>	[31:12]	r	<b>Reserved</b> Read as 0; should be written with 0.



### 21.8.5 Port Output Modification Register

The port output modification register contains control bits that make it possible to individually set, reset, or toggle the logic state of a single port line by manipulating the output register.

#### P0\_OMR

#### Port 0 Output Modification Register

(0004<sub>H</sub>)

Reset Value: 0000 0000<sub>H</sub>

31	30	29	28	27	26	25	24	23	22	21	20	19	18	17	16
<b>PR1 5</b>	<b>PR1 4</b>	<b>PR1 3</b>	<b>PR1 2</b>	<b>PR1 1</b>	<b>PR1 0</b>	<b>PR9</b>	<b>PR8</b>	<b>PR7</b>	<b>PR6</b>	<b>PR5</b>	<b>PR4</b>	<b>PR3</b>	<b>PR2</b>	<b>PR1</b>	<b>PR0</b>
w	w	w	w	w	w	w	w	w	w	w	w	w	w	w	w
15	14	13	12	11	10	9	8	7	6	5	4	3	2	1	0
<b>PS15</b>	<b>PS14</b>	<b>PS13</b>	<b>PS12</b>	<b>PS11</b>	<b>PS10</b>	<b>PS9</b>	<b>PS8</b>	<b>PS7</b>	<b>PS6</b>	<b>PS5</b>	<b>PS4</b>	<b>PS3</b>	<b>PS2</b>	<b>PS1</b>	<b>PS0</b>
w	w	w	w	w	w	w	w	w	w	w	w	w	w	w	w

Field	Bits	Type	Description
<b>PSx</b> (x = 0-15)	x	w	<b>Port 0 Set Bit x</b> Setting this bit will set or toggle the corresponding bit in the port output register P0_OUT. The function of this bit is shown in <a href="#">Table 21-7</a> .
<b>PRx</b> (x = 0-15)	x + 16	w	<b>Port 0 Reset Bit x</b> Setting this bit will reset or toggle the corresponding bit in the port output register P0_OUT. The function of this bit is shown in <a href="#">Table 21-7</a> .

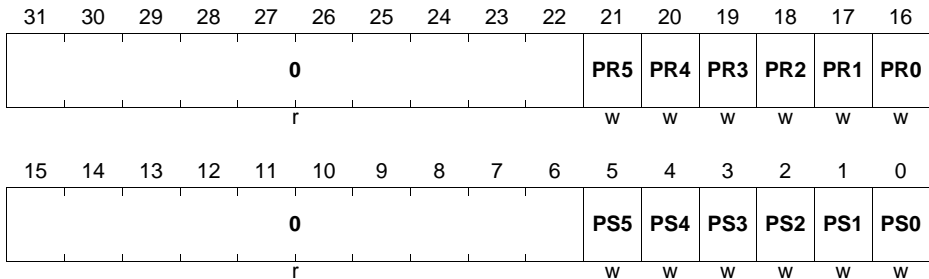
**General Purpose I/O Ports (Ports)**

**P1\_OMR**

**Port 1 Output Modification Register**

(0004<sub>H</sub>)

Reset Value: 0000 0000<sub>H</sub>



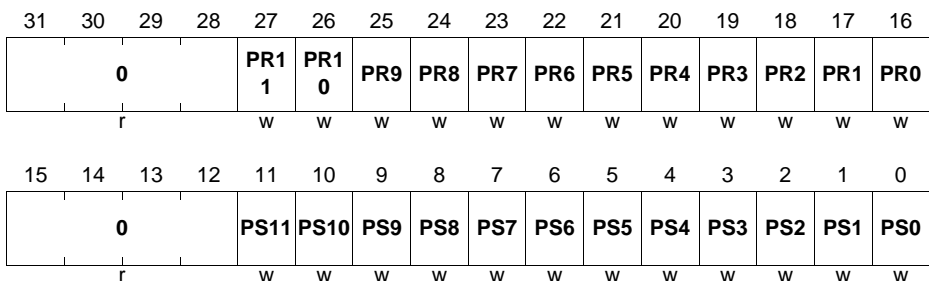
Field	Bits	Type	Description
<b>PSx</b> (x = 0-5)	x	w	<b>Port 1 Set Bit x</b> Setting this bit will set or toggle the corresponding bit in the port output register P1_OUT. The function of this bit is shown in <a href="#">Table 21-7</a> .
<b>PRx</b> (x = 0-5)	x + 16	w	<b>Port 1 Reset Bit x</b> Setting this bit will reset or toggle the corresponding bit in the port output register P1_OUT. The function of this bit is shown in <a href="#">Table 21-7</a> .
<b>0</b>	[15:6], [31:22]	r	<b>Reserved</b> Read as 0; should be written with 0.

**P2\_OMR**

**Port 2 Output Modification Register**

(0004<sub>H</sub>)

Reset Value: 0000 0000<sub>H</sub>



**General Purpose I/O Ports (Ports)**

Field	Bits	Type	Description
<b>PSx</b> (x = 0-11)	x	w	<b>Port 2 Set Bit x</b> Setting this bit will set or toggle the corresponding bit in the port output register P2_OUT. The function of this bit is shown in <a href="#">Table 21-7</a> .
<b>PRx</b> (x = 0-11)	x + 16	w	<b>Port 2 Reset Bit x</b> Setting this bit will reset or toggle the corresponding bit in the port output register P2_OUT. The function of this bit is shown in <a href="#">Table 21-7</a> .
<b>0</b>	[15:12], [31:28]	r	<b>Reserved</b> Read as 0; should be written with 0.

*Note: Register Pn\_OMR is virtual and does not contain any flip-flop. A read action delivers the value of 0. A 8 or 16-bits write behaves like a 32-bit write padded with zeros.*

**Table 21-7 Function of the Bits PRx and PSx**

PRx	PSx	Function
0	0	Bit Pn_OUT.Px is not changed.
0	1	Bit Pn_OUT.Px is set.
1	0	Bit Pn_OUT.Px is reset.
1	1	Bit Pn_OUT.Px is toggled.

### 21.8.6 Port Input Register

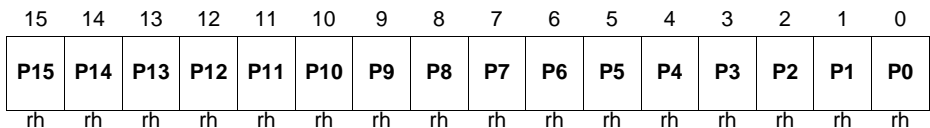
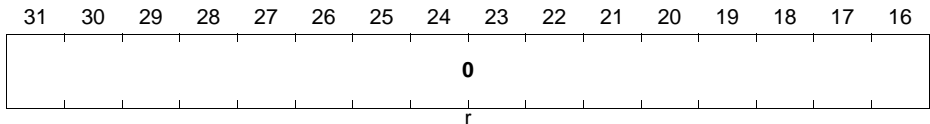
The logic level of a GPIO pin can be read via the read-only port input register Pn\_IN. Reading the Pn\_IN register always returns the current logical value at the GPIO pin, synchronized to avoid meta-stabilities, independently whether the pin is selected as input or output.

#### P0\_IN

**Port 0 Input Register**

**(0024<sub>H</sub>)**

**Reset Value: 0000 XXXX<sub>H</sub>**



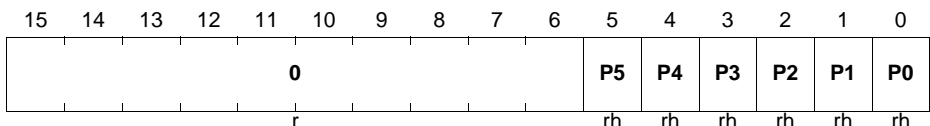
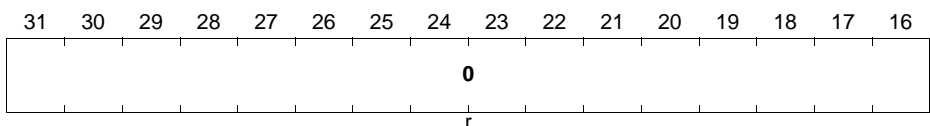
Field	Bits	Type	Description
<b>Px</b> <b>(x = 0-15)</b>	x	rh	<b>Port 0 Input Bit x</b> This bit indicates the level at the input pin P0.x. 0 <sub>B</sub> The input level of P0.x is 0. 1 <sub>B</sub> The input level of P0.x is 1.
<b>0</b>	[31:16]	r	<b>Reserved</b> Read as 0.

#### P1\_IN

**Port 1 Input Register**

**(0024<sub>H</sub>)**

**Reset Value: 0000 00XX<sub>H</sub>**



**General Purpose I/O Ports (Ports)**

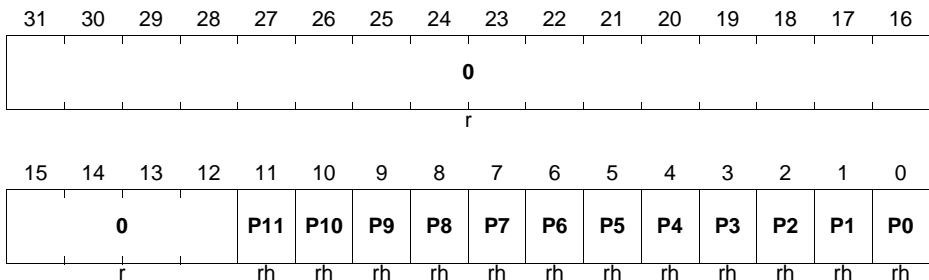
Field	Bits	Type	Description
<b>Px</b> <b>(x = 0-5)</b>	x	rh	<b>Port 1 Input Bit x</b> This bit indicates the level at the input pin P1.x. 0 <sub>B</sub> The input level of P1.x is 0. 1 <sub>B</sub> The input level of P1.x is 1.
<b>0</b>	[31:6]	r	<b>Reserved</b> Read as 0.

**P2\_IN**

**Port 2 Input Register**

**(0024<sub>H</sub>)**

**Reset Value: 0000 0XXX<sub>H</sub>**



Field	Bits	Type	Description
<b>Px</b> <b>(x = 0-11)</b>	x	rh	<b>Port 2 Input Bit x</b> This bit indicates the level at the input pin P2.x. 0 <sub>B</sub> The input level of P2.x is 0. 1 <sub>B</sub> The input level of P2.x is 1.
<b>0</b>	[31:12]	r	<b>Reserved</b> Read as 0.

### 21.8.7 Port Pin Power Save Register

When the XMC1200 enters Deep-Sleep mode, pins with enabled Pin Power Save option are set to a defined state and the input Schmitt-Trigger as well as the output driver stage are switched off.

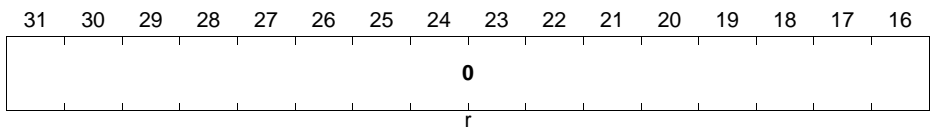
*Note: Do not enable the Pin Power Save function for pins configured for Hardware Control ( $Pn\_HWSEL.HWx \neq 00_B$ ). Doing so may result in an undefined behavior of the pin when the device enters the Deep Sleep state.*

#### P0\_PPS

#### Port 0 Pin Power Save Register

(0070<sub>H</sub>)

Reset Value: 0000 0000<sub>H</sub>



15	14	13	12	11	10	9	8	7	6	5	4	3	2	1	0
<b>PPS</b>	<b>PPS</b>	<b>PPS</b>	<b>PPS</b>	<b>PPS</b>	<b>PPS</b>	<b>PPS</b>	<b>PPS</b>	<b>PPS</b>	<b>PPS</b>	<b>PPS</b>	<b>PPS</b>	<b>PPS</b>	<b>PPS</b>	<b>PPS</b>	<b>PPS</b>
<b>15</b>	<b>14</b>	<b>13</b>	<b>12</b>	<b>11</b>	<b>10</b>	<b>9</b>	<b>8</b>	<b>7</b>	<b>6</b>	<b>5</b>	<b>4</b>	<b>3</b>	<b>2</b>	<b>1</b>	<b>0</b>
rW	rW	rW	rW	rW	rW	rW	rW	rW	rW	rW	rW	rW	rW	rW	rW

Field	Bits	Type	Description
<b>PPS<sub>x</sub></b> <b>(x = 0-15)</b>	x	rW	<b>Port 0 Pin Power Save Bit x</b> 0 <sub>B</sub> Pin Power Save of P0.x is disabled. 1 <sub>B</sub> Pin Power Save of P0.x is enabled.
<b>0</b>	[31:16]	r	<b>Reserved</b> Read as 0.

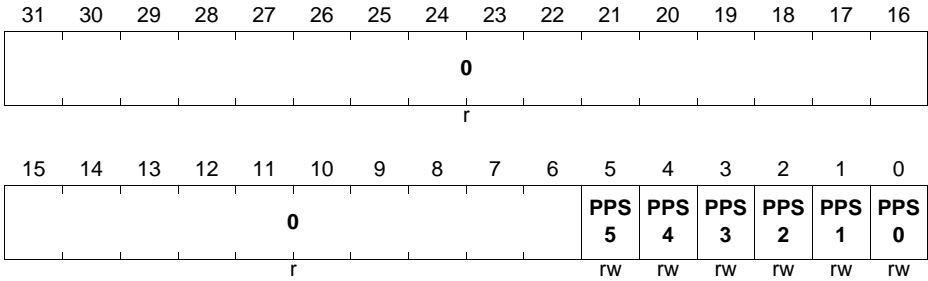
**General Purpose I/O Ports (Ports)**

**P1\_PPS**

**Port 1 Pin Power Save Register**

(0070<sub>H</sub>)

Reset Value: 0000 0000<sub>H</sub>



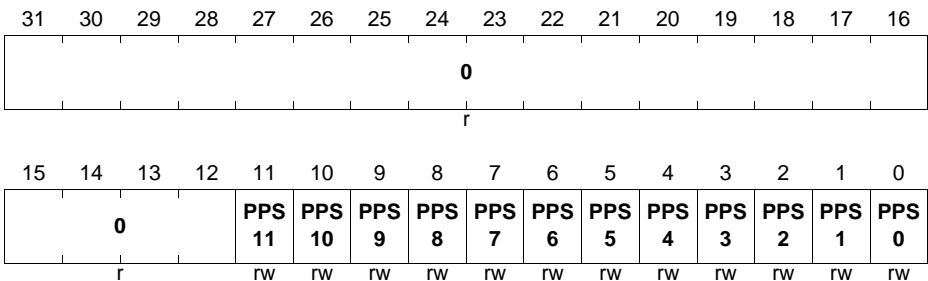
Field	Bits	Type	Description
<b>PPS<sub>x</sub></b> (x = 0-5)	x	rw	<b>Port 1 Pin Power Save Bit x</b> 0 <sub>B</sub> Pin Power Save of P1.x is disabled. 1 <sub>B</sub> Pin Power Save of P1.x is enabled.
<b>0</b>	[31:6]	r	<b>Reserved</b> Read as 0.

**P2\_PPS**

**Port 2 Pin Power Save Register**

(0070<sub>H</sub>)

Reset Value: 0000 0000<sub>H</sub>



**General Purpose I/O Ports (Ports)**

Field	Bits	Type	Description
<b>PPSx</b> <b>(x = 0-11)</b>	x	rw	<b>Port 2 Pin Power Save Bit x</b> 0 <sub>B</sub> Pin Power Save of P2.x is disabled. 1 <sub>B</sub> Pin Power Save of P2.x is enabled.
<b>0</b>	[31:12]	r	<b>Reserved</b> Read as 0.

**Deep-Sleep Pin Power Save behavior**

The actual behavior in Deep-Sleep mode with enabled Pin Power Save is controlled by the Pn\_IOCry.PCx bit field ([Page 21-14](#)) of the respective pin. [Table 21-8](#) shows the coding.

**Table 21-8 PCx Coding in Deep-Sleep mode**

PCx[4:0]	I/O	Normal Operation or PPSx=0 <sub>B</sub>	Deep-Sleep mode and PPSx=1 <sub>B</sub>
0X000 <sub>B</sub>	Direct Input	See <a href="#">Table 21-5</a>	Input value=Pn_OUTx
0X001 <sub>B</sub>			Input value=0 <sub>B</sub> ; pull-down deactivated
0X010 <sub>B</sub>			Input value=1 <sub>B</sub> ; pull-up deactivated
0X011 <sub>B</sub>			Input value=Pn_OUTx, storing the last sampled input value
0X100 <sub>B</sub>	Inverted Input	See <a href="#">Table 21-5</a>	Input value= $\overline{\text{Pn\_OUTx}}$
0X101 <sub>B</sub>			Input value=1 <sub>B</sub> ; pull-down deactivated
0X110 <sub>B</sub>			Input value=0 <sub>B</sub> ; pull-up deactivated
0X111 <sub>B</sub>			Input value= $\overline{\text{Pn\_OUTx}}$ , storing the last sampled input value
1XXXX <sub>B</sub>	Output	See <a href="#">Table 21-5</a>	Output driver off, Input Schmitt-Trigger off, no pull device active, Input value=Pn_OUTx



### 21.8.8 Port Pin Hardware Select Register

Some peripherals require direct hardware control of their I/Os. As multiple such peripheral I/Os are mapped on some pins, the register Pn\_HWSEL is used to select which peripheral has the control over the pin.

*Note: Pn\_HWSEL.HWx just pre-assigns the hardware-control of the pin to a certain peripheral, but the peripheral itself decides when to take control over it. As long as the peripheral does not take control of a given pin via HWx\_EN, the configuration of this pin is still defined by the configuration registers and it is available as GPIO or for other alternate functions. This might be because the selected peripheral has provisions to just activate a subset of its pins, or because the peripheral is not active at all.*

This mechanism can also be used to prohibit the hardware control of certain pins to a peripheral, in case the application does not need the respective functionality and the peripheral has no provisions to disable the hardware control selectively.

#### P0\_HWSEL

##### Port 0 Pin Hardware Select Register (0074<sub>H</sub>)

Reset Value: 0000 0000<sub>H</sub>

31	30	29	28	27	26	25	24	23	22	21	20	19	18	17	16
HW15		HW14		HW13		HW12		HW11		HW10		HW9		HW8	
rw		rw		rw		rw		rw		rw		rw		rw	
15	14	13	12	11	10	9	8	7	6	5	4	3	2	1	0
HW7		HW6		HW5		HW4		HW3		HW2		HW1		HW0	
rw		rw		rw		rw		rw		rw		rw		rw	

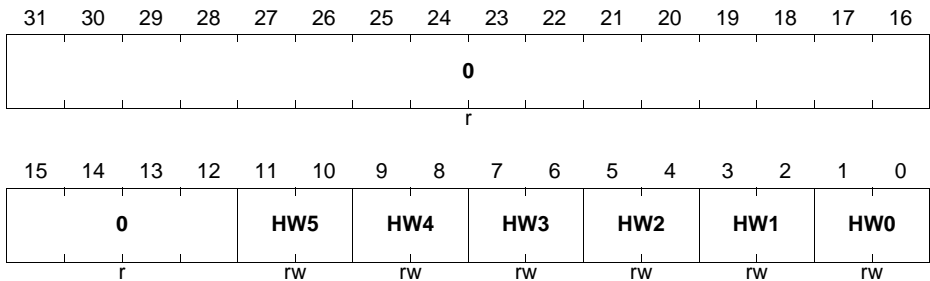
Field	Bits	Type	Description
<b>HWx</b> <b>(x = 0-15)</b>	[2*x+1: 2*x]	rw	<b>Port 0 Pin Hardware Select Bit x</b> 00 <sub>B</sub> Software control only. 01 <sub>B</sub> HW0 control path can override the software configuration. 10 <sub>B</sub> HW1 control path can override the software configuration. 11 <sub>B</sub> Reserved.

**General Purpose I/O Ports (Ports)**

**P1\_HWSEL**

**Port 1 Pin Hardware Select Register (0074<sub>H</sub>)**

**Reset Value: 0000 0000<sub>H</sub>**

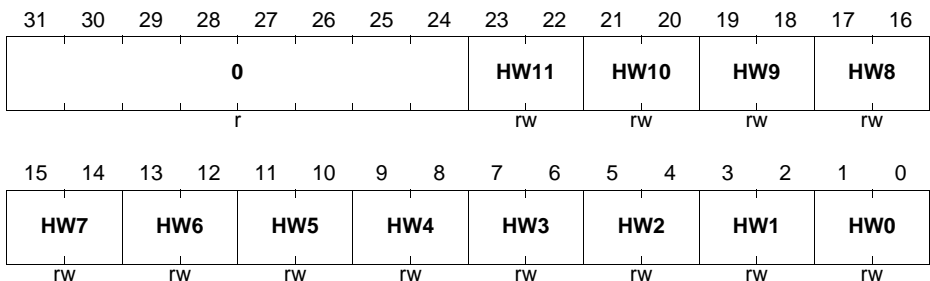


Field	Bits	Type	Description
<b>HWx</b> (x = 0-5)	[2*x+1: 2*x]	rw	<b>Port 1 Pin Hardware Select Bit x</b> 00 <sub>B</sub> Software control only. 01 <sub>B</sub> HW0 control path can override the software configuration. 10 <sub>B</sub> HW1 control path can override the software configuration. 11 <sub>B</sub> Reserved.
<b>0</b>	[31:12]	r	<b>Reserved</b> Read as 0; should be written with 0.

**P2\_HWSEL**

**Port 2 Pin Hardware Select Register (0074<sub>H</sub>)**

**Reset Value: 0000 0000<sub>H</sub>**



**General Purpose I/O Ports (Ports)**

<b>Field</b>	<b>Bits</b>	<b>Type</b>	<b>Description</b>
<b>HWx</b> <b>(x = 0-11)</b>	[2*x+1: 2*x]	rw	<b>Port 2 Pin Hardware Select Bit x</b> 00 <sub>B</sub> Software control only. 01 <sub>B</sub> HW0 control path can override the software configuration. 10 <sub>B</sub> HW1 control path can override the software configuration. 11 <sub>B</sub> Reserved.
<b>0</b>	[31:24]	r	<b>Reserved</b> Read as 0; should be written with 0.

## 21.9 Package Pin Summary

The following general building block is used to describe each pin:

**Table 21-9 Package Pin Mapping Description**

Function	Package A	Package B	...	Pad Type
Px.y	N	N		Pad Class

The table is sorted by the “Function” column, starting with the regular Port pins (Px.y), followed by the supply pins.

The following columns, titled with the supported package variants, lists the package pin number to which the respective function is mapped in that package.

The “Pad Type” indicates the employed pad type:

- STD\_INOUT/AN (standard bi-directional pads with analog input)
- High Current (high current bi-directional pads)
- STD\_IN/AN (standard input pads with analog input)
- Power (power supply)

Details about the pad properties are defined in the Datasheet.

**Table 21-10 Package Pin Mapping**

Function	TSSOP 38	TSSOP 28	TSSOP 16	Pad Type	Notes
P0.0	17	13	7	STD_INOUT/AN	
P0.1	18	-	-	STD_INOUT/AN	
P0.2	19	-	-	STD_INOUT/AN	
P0.3	20	-	-	STD_INOUT/AN	
P0.4	21	14	-	STD_INOUT/AN	
P0.5	22	15	8	STD_INOUT/AN	
P0.6	23	16	9	STD_INOUT/AN	
P0.7	24	17	10	STD_INOUT/AN	

**General Purpose I/O Ports (Ports)**

**Table 21-10 Package Pin Mapping (cont'd)**

<b>Function</b>	<b>TSSOP 38</b>	<b>TSSOP 28</b>	<b>TSSOP 16</b>	<b>Pad Type</b>	<b>Notes</b>
P0.8	27	18	11	STD_INOUT/ AN	
P0.9	28	19	12	STD_INOUT/ AN	
P0.10	29	20	-	STD_INOUT/ AN	
P0.11	30	-	-	STD_INOUT/ AN	
P0.12	31	21	-	STD_INOUT/ AN	
P0.13	32	22	-	STD_INOUT/ AN	
P0.14	33	23	13	STD_INOUT/ AN	
P0.15	34	24	14	STD_INOUT/ AN	
P1.0	16	12	-	High Current	
P1.1	15	11	-	High Current	
P1.2	14	10	-	High Current	
P1.3	13	9	-	High Current	
P1.4	12	-	-	High Current	
P1.5	11	-	-	High Current	
P2.0	35	25	15	STD_INOUT/ AN	
P2.1	36	26	-	STD_INOUT/ AN	
P2.2	37	27	-	STD_IN/AN	
P2.3	38	-	-	STD_IN/AN	
P2.4	1	-	-	STD_IN/AN	
P2.5	2	28	-	STD_IN/AN	
P2.6	3	1	16	STD_IN/AN	
P2.7	4	2	1	STD_IN/AN	

**General Purpose I/O Ports (Ports)**

**Table 21-10 Package Pin Mapping (cont'd)**

Function	TSSOP 38	TSSOP 28	TSSOP 16	Pad Type	Notes
P2.8	5	3	1	STD_IN/AN	
P2.9	6	4	2	STD_IN/AN	
P2.10	7	5	3	STD_INOUT/ AN	
P2.11	8	6	4	STD_INOUT/ AN	
VSS	9	7	5	Power	Supply GND, ADC reference GND
VDD	10	8	6	Power	Supply VDD, ADC reference voltage/ ORC reference voltage
VSSP	25	-	-	Power	I/O port ground
VDDP	26	-	-	Power	I/O port supply

## 21.10 Port I/O Functions

### 21.10.1 Port Pin for Boot Modes

Port functions can be overruled by the boot mode selected. The type of boot mode is selected via BMI. [Table 21-11](#) shows the port pins used for the various boot modes.

**Table 21-11 Port Pin for Boot Modes**

Pin	Boot	Boot Description
P0.13	CS(O)	SSC BSL mode
P0.14	SWDIO_0	Debug mode (SWD)
	SPD_0	Debug mode (SPD)
	RX/TX	ASC BSL half-duplex mode
	RX	ASC BSL full-duplex mode
	SCLK(O)	SSC BSL mode
P0.15	SWDCLK_0	Debug mode (SWD)
	TX	ASC BSL full-duplex mode
	DATA(I/O)	SSC BSL mode
P1.2	SWDCLK_1	Debug mode (SWD)
	TX	ASC BSL full-duplex mode
P1.3	SWDIO_1	Debug mode (SWD)
	SPD_1	Debug mode (SPD)
	RX/TX	ASC BSL half-duplex mode
	RX	ASC BSL full-duplex mode

### 21.10.2 Port I/O Function Description

The following general building block is used to describe each PORT pin:

**Table 21-12 Port I/O Function Description**

Function	Outputs			Inputs		
	ALT1	ALTn	HWO0	HWI0	Input	Input
P0.0		MODA.OU T	MODB.OU T	MODB.INA	MODC.IN A	
Pn.y	MODA.OU T				MODA.INA	MODC.INB

Pn.y is the port pin name, defining the control and data bits/registers associated with it. As GPIO, the port is under software control. Its input value is read via Pn\_IN.y, Pn\_OUT defines the output value.

Up to seven alternate output functions (ALT1/2/3/4/5/6/7) can be mapped to a single port pin, selected by Pn\_IOC.R.PC. The output value is directly driven by the respective module, with the pin characteristics controlled by the port registers (within the limits of the connected pad).

The port pin input can be connected to multiple peripherals. Most peripherals have an input multiplexer to select between different possible input sources.

The input path is also active while the pin is configured as output. This allows to feedback an output to on-chip resources without wasting an additional external pin.

By Pn\_HWSEL ([Chapter 21.8.8](#)) it is possible to select between different hardware “masters” (HWO0/HWI0, HWO1/HWI1). The selected peripheral can take control of the pin(s). Hardware control overrules settings in the respective port pin registers.



**Table 21-13 Port I/O Functions**

Function	Outputs										Inputs										
	ALT1	ALT2	ALT3	ALT4	ALT5	ALT6	ALT7	HW00	HW01	HW10	HW11	Input	Input	Input	Input	Input	Input	Input	Input	Input	
P0.0	ER00_PDOU0	LEDT.S0_LINE7	ER00_GOUT0	CCU40_OUT0	USI00_CH0_SELO0	USI00_CH0_SELO0	LEDT.S0_EXTENDED0	LEDT.S0_EXTENDED0	LEDT.S0_EXTENDED0	LEDT.S0_EXTENDED0	LEDT.S0_EXTENDED0	BCCU0_TRAPPB	CCU40_IN0C	USI00_CH0_DX2A	USI00_CH0_DX2A						
P0.1	ER00_PDOU1	LEDT.S0_LINE6	ER00_GOUT1	CCU40_OUT1	CCU40_OUT8	SCU_VDR0P	LEDT.S0_EXTENDED6	LEDT.S0_EXTENDED6	LEDT.S0_EXTENDED6	LEDT.S0_EXTENDED6	LEDT.S0_EXTENDED6		CCU40_IN1C								
P0.2	ER00_PDOU2	LEDT.S0_LINE5	ER00_GOUT2	CCU40_OUT2	VADC0_EMUX02	VADC0_EMUX02	LEDT.S0_EXTENDED5	LEDT.S0_EXTENDED5	LEDT.S0_EXTENDED5	LEDT.S0_EXTENDED5	LEDT.S0_EXTENDED5		CCU40_IN2C								
P0.3	ER00_PDOU3	LEDT.S0_LINE4	ER00_GOUT3	CCU40_OUT3	EMUX01	EMUX01	LEDT.S0_EXTENDED4	LEDT.S0_EXTENDED4	LEDT.S0_EXTENDED4	LEDT.S0_EXTENDED4	LEDT.S0_EXTENDED4		CCU40_IN3C								
P0.4	BCCU0_OUT0	LEDT.S0_LINE3	LEDT.S0_COL3	CCU40_OUT1	EMUX00	VWDT_SERVICE_0_UF	LEDT.S0_EXTENDED3	LEDT.S0_EXTENDED3	LEDT.S0_EXTENDED3	LEDT.S0_EXTENDED3	LEDT.S0_EXTENDED3										
P0.5	BCCU0_OUT1	LEDT.S0_LINE2	LEDT.S0_COL2	CCU40_OUT0	ACMP2_OUT	ACMP2_OUT	LEDT.S0_EXTENDED2	LEDT.S0_EXTENDED2	LEDT.S0_EXTENDED2	LEDT.S0_EXTENDED2	LEDT.S0_EXTENDED2										
P0.6	BCCU0_OUT2	LEDT.S0_LINE1	LEDT.S0_COL1	CCU40_OUT0	USI00_CH0_MCLKOUT	USI00_CH0_MCLKOUT	LEDT.S0_EXTENDED1	LEDT.S0_EXTENDED1	LEDT.S0_EXTENDED1	LEDT.S0_EXTENDED1	LEDT.S0_EXTENDED1		CCU40_IN0B	USI00_CH1_DX0C	USI00_CH1_DX0C						
P0.7	BCCU0_OUT3	LEDT.S0_LINE0	LEDT.S0_COL0	CCU40_OUT1	USI00_CH0_SCLKOUT	USI00_CH0_SCLKOUT	LEDT.S0_EXTENDED0	LEDT.S0_EXTENDED0	LEDT.S0_EXTENDED0	LEDT.S0_EXTENDED0	LEDT.S0_EXTENDED0		CCU40_IN1B	USI00_CH0_DX0C	USI00_CH1_DX0C	USI00_CH1_DX0C					
P0.8	BCCU0_OUT4	LEDT.S1_LINE0	LEDT.S0_COL4	CCU40_OUT2	SCUOUT	SCUOUT	LEDT.S1_EXTENDED0	LEDT.S1_EXTENDED0	LEDT.S1_EXTENDED0	LEDT.S1_EXTENDED0	LEDT.S1_EXTENDED0		CCU40_IN2B	USI00_CH0_DX1B	USI00_CH1_DX1B						
P0.9	BCCU0_OUT5	LEDT.S1_LINE1	LEDT.S0_COL6	CCU40_OUT3	USI00_CH0_SELO0	USI00_CH0_SELO0	LEDT.S1_EXTENDED1	LEDT.S1_EXTENDED1	LEDT.S1_EXTENDED1	LEDT.S1_EXTENDED1	LEDT.S1_EXTENDED1		CCU40_IN0B	USI00_CH0_DX2B	USI00_CH1_DX2B						
P0.10	BCCU0_OUT6	LEDT.S1_LINE2	LEDT.S0_COL5	ACMP0_OUT	USI00_CH0_SELO1	USI00_CH0_SELO1	LEDT.S1_EXTENDED2	LEDT.S1_EXTENDED2	LEDT.S1_EXTENDED2	LEDT.S1_EXTENDED2	LEDT.S1_EXTENDED2			USI00_CH0_DX2C	USI00_CH1_DX2C						
P0.11	BCCU0_OUT7	LEDT.S1_LINE3	LEDT.S0_COL4	USI00_CH0_MCLKOUT	USI00_CH0_SELO2	USI00_CH0_SELO2	LEDT.S1_EXTENDED3	LEDT.S1_EXTENDED3	LEDT.S1_EXTENDED3	LEDT.S1_EXTENDED3	LEDT.S1_EXTENDED3										
P0.12	BCCU0_OUT8	LEDT.S1_LINE4	LEDT.S0_COL3	LEDT.S1_COL3	USI00_CH0_SELO3	USI00_CH0_SELO3	LEDT.S1_EXTENDED4	LEDT.S1_EXTENDED4	LEDT.S1_EXTENDED4	LEDT.S1_EXTENDED4	LEDT.S1_EXTENDED4										
P0.13	VWDT_SERVICE_0_UF	LEDT.S1_LINE5	LEDT.S0_COL2	LEDT.S1_COL2	USI00_CH0_SELO4	USI00_CH0_SELO4	LEDT.S1_EXTENDED5	LEDT.S1_EXTENDED5	LEDT.S1_EXTENDED5	LEDT.S1_EXTENDED5	LEDT.S1_EXTENDED5										
P0.14	BCCU0_OUT7	LEDT.S1_LINE6	LEDT.S0_COL1	LEDT.S1_COL1	USI00_CH0_SCLKOUT	USI00_CH0_SCLKOUT	LEDT.S1_EXTENDED6	LEDT.S1_EXTENDED6	LEDT.S1_EXTENDED6	LEDT.S1_EXTENDED6	LEDT.S1_EXTENDED6										
P0.15	BCCU0_OUT8	LEDT.S1_LINE7	LEDT.S0_COL0	LEDT.S1_COL0	USI00_CH0_MCLKOUT	USI00_CH0_MCLKOUT	LEDT.S1_EXTENDED7	LEDT.S1_EXTENDED7	LEDT.S1_EXTENDED7	LEDT.S1_EXTENDED7	LEDT.S1_EXTENDED7										
P1.0	BCCU0_OUT0	USI00_CH0_OUT0	LEDT.S0_COL0	LEDT.S1_COL4	ACMP1_OUT	USI00_CH0_SELO0	USI00_CH0_DOUT0	USI00_CH0_DOUT0	USI00_CH0_DOUT0	USI00_CH0_DOUT0	USI00_CH0_DOUT0										
P1.1	VADC0_EMUX00	LEDT.S0_OUT1	LEDT.S0_COL1	LEDT.S1_COL0	USI00_CH0_SELO1	USI00_CH0_SELO1	USI00_CH0_DOUT1	USI00_CH0_DOUT1	USI00_CH0_DOUT1	USI00_CH0_DOUT1	USI00_CH0_DOUT1										
P1.2	VADC0_EMUX01	LEDT.S0_OUT2	LEDT.S0_COL2	LEDT.S1_COL1	ACMP2_OUT	USI00_CH0_SELO2	USI00_CH0_DOUT2	USI00_CH0_DOUT2	USI00_CH0_DOUT2	USI00_CH0_DOUT2	USI00_CH0_DOUT2										
P1.3	VADC0_EMUX02	CCU40_OUT3	LEDT.S0_COL3	LEDT.S1_COL2	USI00_CH0_SCLKOUT	USI00_CH0_SCLKOUT	USI00_CH0_DOUT3	USI00_CH0_DOUT3	USI00_CH0_DOUT3	USI00_CH0_DOUT3	USI00_CH0_DOUT3										
P1.4	VADC0_EMUX10	USI00_CH0_SCLKOUT	LEDT.S0_COL4	LEDT.S1_COL3	USI00_CH0_SELO3	USI00_CH0_SELO3	USI00_CH0_DOUT4	USI00_CH0_DOUT4	USI00_CH0_DOUT4	USI00_CH0_DOUT4	USI00_CH0_DOUT4										
P1.5	VADC0_EMUX11	USI00_CH0_OUT0	LEDT.S0_COL4	BCCU0_OUT1	USI00_CH0_SELO4	USI00_CH0_SELO4	USI00_CH0_DOUT5	USI00_CH0_DOUT5	USI00_CH0_DOUT5	USI00_CH0_DOUT5	USI00_CH0_DOUT5										

**Table 21-13 Port I/O Functions (cont'd)**

Function	Outputs											Inputs										
	ALT1	ALT2	ALT3	ALT4	ALT5	ALT6	ALT7	HW00	HW01	HW10	HW11	Input	Input	Input	Input	Input	Input	Input	Input	Input	Input	
P2.0	ERU0_PDDUT3	CCU40_OUT0	ERU0_GOUT3	LEDS1_COL3		USIC0_CH0_DOUT0	USIC0_CH0_SCLKOUT					VDDC0_GCH5		ERU0_0B0	USIC0_CH0_DXE	USIC0_CH0_DXE	USIC0_CH0_DXE	USIC0_CH0_DXE	USIC0_CH0_DXE	USIC0_CH0_DXE	USIC0_CH0_DXE	USIC0_CH0_DXE
P2.1	ERU0_PDDUT2	CCU40_OUT1	ERU0_GOUT2	LEDS1_COL6		USIC0_CH0_DOUT0	USIC0_CH1_SCLKOUT					VDDC0_GCH6	ACMP2_INP	ERU0_1B0	USIC0_CH0_DMF	USIC0_CH0_DXA	USIC0_CH0_DXA	USIC0_CH0_DXA	USIC0_CH0_DXA	USIC0_CH0_DXA	USIC0_CH0_DXA	USIC0_CH0_DXA
P2.2												VDDC0_GCH7	ACMP2_INN	ERU0_0B1	USIC0_CH0_DXA	USIC0_CH0_DXA	USIC0_CH0_DXA	USIC0_CH0_DXA	USIC0_CH0_DXA	USIC0_CH0_DXA	USIC0_CH0_DXA	USIC0_CH0_DXA
P2.3												VDDC0_GCH5		ERU0_1B1	USIC0_CH0_DXS	USIC0_CH0_DXS	USIC0_CH0_DXS	USIC0_CH0_DXS	USIC0_CH0_DXS	USIC0_CH0_DXS	USIC0_CH0_DXS	USIC0_CH0_DXS
P2.4												VDDC0_GCH6		ERU0_0A1	USIC0_CH0_DXS	USIC0_CH0_DXS	USIC0_CH0_DXS	USIC0_CH0_DXS	USIC0_CH0_DXS	USIC0_CH0_DXS	USIC0_CH0_DXS	USIC0_CH0_DXS
P2.5												VDDC0_GCH7		ERU0_1A1	USIC0_CH0_DXS	USIC0_CH0_DXS	USIC0_CH0_DXS	USIC0_CH0_DXS	USIC0_CH0_DXS	USIC0_CH0_DXS	USIC0_CH0_DXS	USIC0_CH0_DXS
P2.6												VDDC0_GCH0	ACMP1_INN	ERU0_2A1	USIC0_CH0_DXS	USIC0_CH0_DXS	USIC0_CH0_DXS	USIC0_CH0_DXS	USIC0_CH0_DXS	USIC0_CH0_DXS	USIC0_CH0_DXS	USIC0_CH0_DXS
P2.7												VDDC0_GCH1	ACMP1_INP	ERU0_3A1	USIC0_CH0_DXS	USIC0_CH0_DXS	USIC0_CH0_DXS	USIC0_CH0_DXS	USIC0_CH0_DXS	USIC0_CH0_DXS	USIC0_CH0_DXS	USIC0_CH0_DXS
P2.8												VDDC0_GCH1	ACMP1_INN	ERU0_3B1	USIC0_CH0_DXS	USIC0_CH0_DXS	USIC0_CH0_DXS	USIC0_CH0_DXS	USIC0_CH0_DXS	USIC0_CH0_DXS	USIC0_CH0_DXS	USIC0_CH0_DXS
P2.9												VDDC0_GCH2	ACMP3_INP	ERU0_3B0	USIC0_CH0_DXA	USIC0_CH0_DXA	USIC0_CH0_DXA	USIC0_CH0_DXA	USIC0_CH0_DXA	USIC0_CH0_DXA	USIC0_CH0_DXA	USIC0_CH0_DXA
P2.10	ERU0_PDDUT1	CCU40_OUT2	ERU0_GOUT1	LEDS1_COL4		ACMP3_OUT_DOUT0	USIC0_CH1_DOUT0					VDDC0_GCH3		ERU0_2B0	USIC0_CH0_DXS	USIC0_CH0_DXS	USIC0_CH0_DXS	USIC0_CH0_DXS	USIC0_CH0_DXS	USIC0_CH0_DXS	USIC0_CH0_DXS	USIC0_CH0_DXS
P2.11	ERU0_PDDUT0	CCU40_OUT3	ERU0_GOUT0	LEDS1_COL3		USIC0_CH1_SCLKOUT	USIC0_CH1_DOUT0					VDDC0_GCH4	ACMP_REF	ERU0_3B1	USIC0_CH0_DXE	USIC0_CH0_DXE	USIC0_CH0_DXE	USIC0_CH0_DXE	USIC0_CH0_DXE	USIC0_CH0_DXE	USIC0_CH0_DXE	USIC0_CH0_DXE

# **Boot and Startup, Bootstrap Loaders, and User Routines**

## 22 Boot and Startup

The startup sequence of the XMC1200 is a process taking place before user application software takes control of the system and is comprising of two major phases (see [Figure 22-1](#)), split in several distinctive steps:

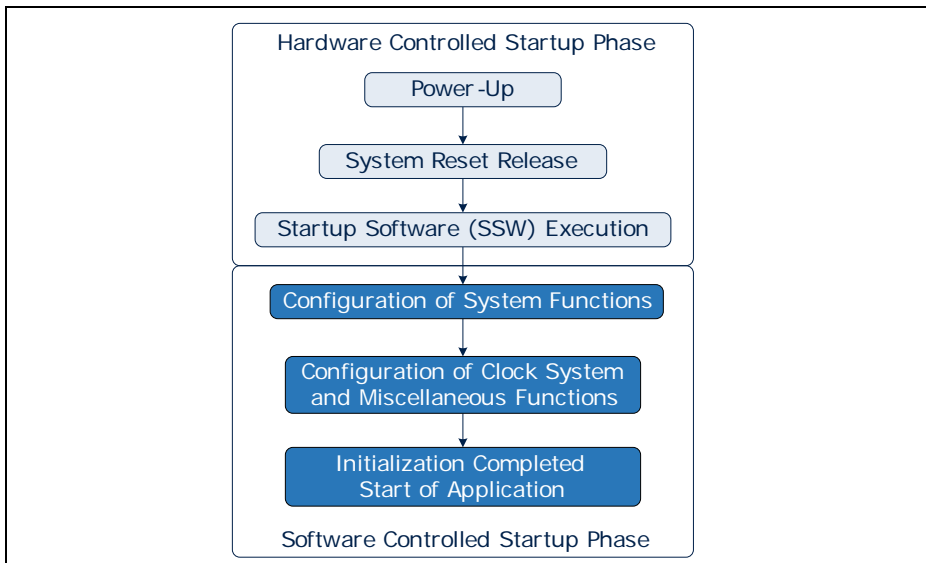
### Hardware Controlled Startup Phase

The hardware controlled startup phase gets performed automatically after power up of the microcontroller. This part is generic and it ensures basic configuration common to most applications. The hardware setup needs to ensure fulfillment of requirements specified in Data Sheet in order to enable reliable start up of the microcontroller before control is handed over to the user software. The sequence where boot code gets executed is considered a part of the hardware controlled phase of the startup sequence.

For details of the setup requirements, please refer to Data Sheet.

### Software Controlled Startup Phase

The software controlled startup phase is the part where the application specific configuration gets applied with user software. It involves several steps that are critical for proper operation of the microcontroller in the application context and may also involve some optional configuration actions in order to improve system performance and stability in the application context.



**Figure 22-1 Startup sequence**

## 22.1 Startup Sequence and System Dependencies

A more detailed description of the startup sequence is available in the following sub-chapters.

### 22.1.1 Power-Up

Power up of the microcontroller gets performed by applying  $V_{DDP}$  supply (for details of the supply requirements, please refer to Data Sheet). Once  $V_{DDP}$  reaches a threshold, the internal core voltage,  $V_{DDC}$ , is generated automatically by the EVR.

### 22.1.2 System Reset Release

The internal power-on reset generation is based on the supply and core voltage validation. When  $V_{DDP}$  and  $V_{DDC}$  reaches a stable threshold level, the power-on reset is released. Next, after the on-chip oscillators generate a stable clock output, the system reset is released automatically and the SSW code starts to run.

The system reset can be triggered from various sources like software controlled CPU reset register or a watchdog time-out-triggered reset. For more details on reset control details, please refer to the Reset Control Unit (RCU) section in the SCU chapter.

The cause of the last reset gets automatically stored in the SCU\_RSTSTAT register and can be checked by user software to determine the state of the system and for debug purpose. The reset status in the SCU\_RSTSTAT register shall be reset with SCU\_RSTCLR register after each startup in order to ensure consistent source indication after the next reset.

After reset release, MCLK and PCLK are running at 8MHz and most of the peripherals' clocks are disabled except for CPU, memories and PORT. It is recommended to disable the clock of the unused modules in order to reduce power consumption.

### 22.1.3 Startup Software (SSW) Execution

After the reset is deasserted, CPU starts to execute the SSW code from the ROM memory. To indicate the start of the SSW execution, the pullup device in P0.8 is enabled. Pullup device is disabled during reset.

Another important task that is done by SSW is to read the Boot Mode Index (BMI) stored in Flash and decide the startup mode (such as User Productive mode and Bootstrap Loader) selected by the user. For more details about the various startup modes and handling of BMI, please refer to [Section 22.2](#).

To handle the initial hardfault error during the SSW execution, SSW installs "jump to itself" instruction at SRAM location  $2000'000C_H$  as temporary HardFault handler - until the user code installs its own. It is installed upon master reset only.

During SSW execution, the SRAM area between 2000'00C0<sub>H</sub> and 2000'0200<sub>H</sub> is reserved for usage by XMC1200 SSW, therefore the user software should not store in this area data which must be preserved throughout (non-power) resets.

The MCLK and PCLK frequency that is used to execute the SSW and to start the user code can be configured by user. In addition, some of the peripheral clock can also be enabled (default disabled) by the SSW. Detailed description can be found in the [Section 22.1.3.1](#).

### 22.1.3.1 Clock system handling by SSW

XMC1200 SSW is able to change device clock settings to allow flexibility of device performance e.g. speed vs. power consumption optimization during start-up.

The clock handling by SSW is user configurable by installing values in Flash. For this purpose two word locations - CLK\_VAL1 and CLK\_VAL2 - are assigned in Flash (refer to [Table 22-1](#)), the values from these locations are processed by SSW as follows:

- if CLK\_VAL1[31]=0 - CLK\_VAL1[19:0] bits are installed into SCU\_CLKCR[19:0] register - this configures clock dividers and selection
- if CLK\_VAL2[31]=0 - CLK\_VAL2[10:0] bits are installed into SCU\_CGATCLR0[10:0] - this enables the clock of the selected peripherals

In case some CLK\_VALx location is not programmed by the user - like in device delivery state - its bit[31]=1 and no installation is done into the respective register(s).

#### Limited device frequency change

To avoid big jumps/drops in power consumption, the user-configurable value to be installed during start-up from CLK\_VAL1 into CLKCR.IDIV is limited to the range 1..16, resulting in possible range of MCLK after re-configuration 2..32 MHz from initial 8MHz - i.e. MCLK frequency can be increased or decreased no more than 4 times (rounded, ignoring potential FDIV influence).

In case CLK\_VAL1 (refer to [Table 22-1](#)) contains IDIV value out of the 1..16 range:

- if IDIV=0 - SSW installs IDIV=1 instead
- if IDIV>16 - SSW install IDIV=16 instead

### 22.1.4 Configuration of Special System Functions as part of User code initialization

Special system functions are may be required to perform actions that improve system stability and robustness. The following special system functions or modules require initialization as part of the User code initialization before the actual user application starts:

- Start Address and Initial Stack Pointer Value
- Setup the Interrupt handler

- Supply Voltage Brown-out Detection
- Watchdog Timer (WDT)

### Start Address and Initial Stack Pointer Value

The start address and the initial stack pointer values in [Table 22-1](#) need to be defined by the user. It can be done together with the downloading of the user code into the flash memory.

### Setup the Interrupt Handler

The vector table is remapped to the SRAM based on the remapped vector table in CPU chapter. The interrupt service routine can be placed in these SRAM address or user can also have a branch instruction to the routine that is placed in other memory location. For details, please refer to CPU chapter.

### V<sub>DDP</sub> Brown Out Detection

V<sub>DDP</sub> brown out detection mechanism allow active monitoring of the supply voltage and a corrective reaction in case the voltage level is below a programmed threshold. An interrupt request will be flagged if a programmed condition is detected. For details, please refer to the Power Control Unit (PCU) section in the SCU chapter.

### Watchdog Timer

The Watchdog Timer requires a clock source selection and activation. It is highly recommended to use reliable clock source, preferably independent from the system clock source in order to ensure corrective action in case of a system failure which will bring the microcontroller into a safe operation state. In XMC1200, the default WDT clock is the standby clock. For more details, please refer to WDT chapter. For details of the WDT module configuration please refer to the “Initialization and Control Sequence” section of the WDT chapter.

## 22.1.5 Configuration of Clock System and Miscellaneous Functions

The following functions are available and may require configuration in the user code:

- Clock System Configuration
- System Reset Configuration
- Debug Suspend Configuration

### Clock System Configuration

MCLK and PCLK frequency can be configured to be different from the user settings during SSW execution as described in [Section 22.1.3.1](#). The SCU\_CRCLK.IDIV/FDIV bits are used to program the target clock frequency. The ratio between MCLK and PCLK is also selectable via bit SCU\_CRCLK.PCLKSEL. In addition, some of the peripheral

clocks can be enable/disable via the SCU\_CGATCLR0/SCU\_CGATSET0 register respectively. It is also recommended to enable the oscillator watchdog for loss of clock detection.

### **System Reset Configuration**

Several events such as Flash ECC error or SRAM parity error can be used to trigger a system reset using the SCU\_RSTCON register. For details, please refer to the reset control unit (RCU) section in the SCU chapter.

### **Debug Suspend Configuration**

The XMC1200 device supports a suspend capability for peripherals, if the program execution of the CPU is stopped by the debugger, e.g. with a breakpoint, or with the C\_HALT. This allows the debugging of critical states of the whole microcontroller. The suspend function has to be enabled or disabled locally at the peripheral based on the application and the debugging approach. Refer to Debug System chapter for details.

## **22.2 Start-up Modes**

Startup Software (short name SSW) is the first software executed by CPU after any device leaves reset state.

SSW is stored in the ROM memory, but nevertheless its flow is influenced by other “flexible” factors as:

- type of the event triggering SSW execution
- start-up configuration as selected by the user in so called Boot Mode Index (short notation BMI)

### **22.2.1 Start-up modes in XMC1200**

Start-up mode selection in XMC1200 is done by the SSW after reset. It is based on **Boot Mode Index (BMI)** stored in flash configuration sector 0 (CS0) meaning no device pin is used for configuration purpose. To program a new BMI, user need to call the user function “Request BMI installation” as described in the BSL and User Routines chapter. The selection and handling of BMI by SSW is described in **Section 22.2.3**. The default start-up mode in device delivery state is the ASC BSL mode.

A summary of the supported start-up modes follows.

#### **22.2.1.1 User productive mode**

User code is started from Flash memory, no debugging is possible in this mode.

The address of the first user instruction - to where SSW jumps at its end - is taken from Flash location 1000'1004<sub>H</sub>.



SSW does not check either the target address is inside user Flash. Therefore HardFault will be generated if it's outside and the execution will jump to exception handler in SRAM (upon master reset an endless loop is installed by SSW).

### **22.2.1.2 User mode with debug enabled**

User code is started from Flash memory, the first address is determined as in [User productive mode](#) (see [Section 22.2.1.1](#)).

Debug interface is configured according to [Boot Mode Index \(BMI\)](#) value and enabled.

### **22.2.1.3 User mode with debug enabled and Halt After Reset (HAR)**

User code is started from Flash memory as in the two modes above.

Debug interface is configured according to BMI value and enabled, the CPU is stalled upon exit from SSW and before the first user instruction (for the handling refer to [Section 22.2.3.2](#)).

### **22.2.1.4 Standard Bootstrap Loader modes**

In this mode (short notation Standard BSL):

- user code is downloaded into SRAM
- at the SSW end the execution jumps to SRAM
- no debugging is possible

The Standard BSL mode supported in XMC1200 uses USIC0 module for communication with the host:

- ASC - using channel 0 or 1 (auto-detection by firmware) of USIC0 module and ASC (UART) protocol for download  
This is the default start-up mode - selected by BMI value in device delivery state.
- SSC - using USIC0 channel 0 and SSC (SPI) standard protocol for download  
In this mode SPI-compatible serial EEPROM is supposed to be connected as slave device to XMC1200.

The functionality of standard BSL routines is described in the BSL chapter.

### **22.2.1.5 Bootstrap Loader modes with time-out**

These modes are using the Standard BSL routines for downloading, but the functionality is different:

- SSW first checks either an external device is connected/active, meaning SSW waits to receive Start and Header Bytes from the host - either via USIC channel 0 or 1 - for time-out which duration is taken from BMI.BLSTO (refer to [Section 22.2.2](#)):

- if yes
  - \* user code is downloaded into SRAM
  - \* at the SSW end the execution jumps to SRAM
- if not - at the SSW end the execution jumps to Flash as in **User productive mode**
- no debugging is possible in this mode, independently either code execution starts from Flash or SRAM

Two BSL modes with time-out are supported in XMC1200, both using USIC0 module for communication with the host. Besides the difference in interface selection, also the check performed as part from the above sequence is different:

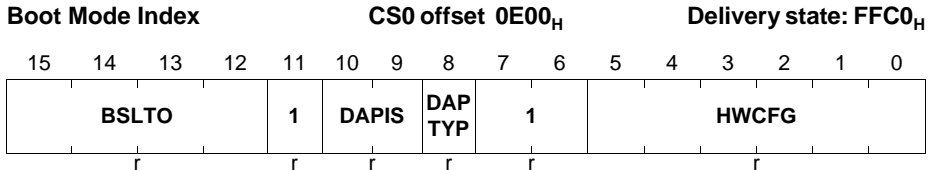
- ASC mode
  - SSW configures USIC0 channels 0 and 1 in ASC (UART) mode
  - SSW waits to receive Start and Header Bytes from the host - either via channel 0 or 1 - for time-out which duration is taken from BMI.BLSTO (refer to **Section 22.2.2**)
  - if Start+Header Bytes are received - Standard ASC BSL is further executed for downloading and starting user code from SRAM; otherwise execution from Flash will be taken
- SSC mode
  - SSW configures USIC0 channel 0 as Master in SSC (SPI) mode
  - SSW initiates communication with SPI-compatible serial EEPROM supposed to be connected as slave device
  - if data received upon Read Command sent by SSW corresponds to the expected (serial EEPROM) protocol - Standard SSC BSL is further executed for downloading and starting user code from SRAM; otherwise execution from Flash will be taken

*Note: If BSLTO=0 is configured in BMI - SSW at all does not perform any BSL check but directly takes User Productive Mode.*

### 22.2.2 Boot Mode Index (BMI)

The Boot Mode Index is 2 Byte value stored in Flash (refer to [Table 22-1](#)) and holding information about start-up mode and debug configuration of the device. Additionally to BMI at 1000'0E00<sub>H</sub> its inverse value is stored at 1000'0E10<sub>H</sub> for check purposes.

#### BMI



Field	Bits	Typ	Description
<b>HWCFG</b>	[5:0]	r	<b>Start-up mode selection:</b> 000000 <sub>B</sub> ASC Bootstrap Loader mode (ASC_BSL) 000001 <sub>B</sub> User productive Mode (UPM) 000011 <sub>B</sub> User mode with debug enabled (UMD) 000111 <sub>B</sub> User mode with debug enabled and HAR (UMHAR) 001000 <sub>B</sub> SSC Bootstrap Loader mode (SSC_BSL) 010000 <sub>B</sub> ASC BSL mode with time-out (ASC_BSLTO) 011000 <sub>B</sub> SSC BSL mode with time-out (SSC_BSLTO) 101010 <sub>B</sub> Secure Bootstrap Loader mode (SBSL) <sup>1)</sup> else Not defined <sup>2)</sup>
<b>DAPTYP</b>	8	r	<b>DAP Type Selection</b> Coding as of SCU_DAPCON.DAPTYP
<b>DAPDIS</b>	[10:9]	r	<b>SWD/SPD Input/Output Selection</b> Coding as of SCU_DAPCON.DAPDIS
<b>BSLTO</b>	[15:12]	r	<b>ASC BSL Time-out value</b> The time-out duration is BSLTO*2664000 MCLK cycles, the supported time-out range is 0.3-5s (333...4995ms)
<b>1</b>	[7:6], 11	r	<b>Reserved, must be programmed to 1</b>

1) Only in device versions supporting it

2) ATTENTION: Installing one of these values will cause device delivery state to be restored upon the next reset - refer to [Section 22.2.3](#)

### 22.2.3 Start-up mode selection

The start-up modes in XMC1200 are selected and handled according to Boot Mode Index (BMI) value read from Flash - refer to [Section 22.2.1](#).

The BMI evaluation can lead to:

- taking User mode - SSW will jump at its end into User Flash and start execution from the location which address is stored at  $1000'1004_H$  if:
  - a kind of User Mode is selected in BMI
  - ASC BSL with time-out is selected but no valid Start+Header Bytes are received within the selected time frame
- taking Bootstrap Loader mode - executing ASC BSL then jumping into SRAM at  $2000'0200_H$
- taking Secure Bootstrap Loader (SBSL) mode - if SBSL is selected in BMI and supported for the device
- executing (endless) loop - waiting for valid Start+Header Bytes to be received via ASC upon ASC BSL mode selected without time-out
- erasing the complete user Flash and installing ASC BSL (or SBSL if supported) mode as new BMI value - upon invalid BMI value or if Secure BSL is selected but not supported for the device. Afterwards master reset is triggered and device is started in a mode according to the new BMI.

#### 22.2.3.1 BMI handling by SSW

This SSW part is intended to be executed after the user function (in ROM) "Request BMI installation" (described in the BSL and User Routines chapter) has been called and has triggered a system reset. Therefore the conditions under which this handling is performed are:

- the last reset was a system reset requested by CPU
- the two half words of SSW0 register are inverse to each other

If all the above conditions are true, the SSW considers SSW0[15:0] content as new BMI value to be installed and executes the following:

- check either the current BMI (in CS0) is User\_Productive AND the new value is NOT User\_Productive:
  - if yes - erase the complete user Flash and install ASC\_BSL (or SBSL if supported) mode as new BMI value
  - if not - install the new BMI value from SSW0[15:0]
- instal all zero in SSW0 to indicate no BMI-programming upon the next reset
- request master reset to be triggered

Upon the last action, a master reset is triggered and a next SSW execution will start with the new BMI value installed in CS0.

### 22.2.3.2 Debug system handling

If debug system must be enabled - start-up mode with debug support is selected in Boot Mode Index (refer to [Section 22.2.2](#)) - SSW performs the following:

- configure the debug interface from BMI value
- enable the debug interface
- if start-up mode with Halt After Reset request (UMHAR) is selected in BMI upon master reset - enter an endless NOP (no operation) loop. From this point on, an external tool (debugger) can take over the control of the device, in particular:
  - if/when a debugger connects to device, it can halt the CPU and check BMI and/or the core program counter (PC) register
  - if HAR is selected, this can be identified by BMI value (refer to [Section 22.2.2](#)) and the PC value will point inside the ROM. The debugger can then manipulate PC and start the user code as desired - the default start address (taken without HAR) is according to the content at location 1000'1004<sub>H</sub> in user Flash (refer to [Table 22-1](#))

## 22.3 Data in Flash for SSW and User SW

[Table 22-1](#) shows the data in Flash which is relevant for SSW execution and can be used by user software in XMC1200.

**Table 22-1 Flash data for SSW and user SW in XMC1200**

Address	Length	Function	Target location
Start-up mode selection:			
1000'0E00 <sub>H</sub>	2 B	Boot Mode Index (BMI)	---
1000'0E10 <sub>H</sub>	2 B	Inverse BMI	---
Chip Identification:			
1000'0F00 <sub>H</sub>	4 B	Chip ID	SCU_IDCHIP
1000'0F04 <sub>H</sub>	28 B	Chip Variant Identification Number	---
1000'0FF0 <sub>H</sub>	16 B	Unique Chip ID	---
Temperature-sensor related data:			
1000'0F20 <sub>H</sub>	2 B	ANA_TSE_k1	---
1000'0F22 <sub>H</sub>	2 B	ANA_TSE_k3	---
1000'0F24 <sub>H</sub>	4 B	ANA_TSE_k2	---
1000'0F28 <sub>H</sub>	2 B	ANATSEMON_min	---
1000'0F2A <sub>H</sub>	2 B	ANATSEMON_max	---
DCO calibration data:			

**Table 22-1 Flash data for SSW and user SW in XMC1200**

Address	Length	Function	Target location
1000'0F40 <sub>H</sub>	2 B	DCO_ADJL_RT Frequency Low Adjustment value measured at room temperature (5 LSbits)	---
1000'0F42 <sub>H</sub>	2 B	DCO_ADJL_HT Frequency Low Adjustment value measured at high temperature (5 LSbits)	---
Application software related data:			
1000'1000 <sub>H</sub>	4 B	Initial Stack Pointer value after SSW	SP_main
1000'1004 <sub>H</sub>	4 B	Start address after SSW in User modes	PC
Clock system related data:			
1000'1010 <sub>H</sub>	4 B	Clock configuration value CLK_VAL1	If bit[31]=0: bits[19:0] into SCU_CLKCR[19:0]
1000'1014 <sub>H</sub>	4 B	Clock gating configuration value CLK_VAL2	If bit[31]=0: bits[10:0] into SCU_CGATCLR0[10:0]

## 23 Bootstrap Loaders (BSL) and User Routines

This chapter describes the Bootstrap Loaders (BSL) and the user-accessible routines in the ROM memory.

The ASC (UART) BSL ([Section 23.1](#)) and the SSC BSL ([Section 23.2](#)) is entered with the BMI settings as described in the Boot and Startup Chapter. The main purpose of BSL Mode is to allow easy and quick programming/erasing of the Flash.

[Section 23.3](#) describes 5 user-accessible routines that can be called by application software. These routines are located in the ROM memory.

### 23.1 ASC (UART) Bootstrap Loader

ASC (UART) Standard Bootstrap Loader (ASC BSL) in XMC1200 uses USIC0 module to download code/data into SRAM starting at address 2000'0200H.

After the last code/data Byte is received and stored, the Startup Software starts user code from address 20000'0200H.

#### 23.1.1 Pin usage

ASC BSL in XMC1200 is selected by a single BMI value but it allows to download user code/data via several variants of pins, modes and USIC0 channels:

- Channel 0
  - full duplex mode with RxD at P0.14 and TxD at P0.15
  - half duplex mode with RxD/TxD at P0.14
- Channel 1
  - full duplex mode with RxD at P1.3 and TxD at P1.2
  - half duplex mode with RxD/TxD at P1.3

*Note: The above set of pins also accommodate all the assignments for SWD/SPD (debug) interfaces.*

#### 23.1.2 ASC BSL execution flow

The complete ASC Bootstrap Loader procedure consists of two parts as described below.

##### 23.1.2.1 ASC BSL entry check sequence

Downloading is only initiated after a Start (zero) and a Header (described below) Bytes are received through one of the channels whereas both the channels are active ("listening") until the selection is done by the routine itself as follows:

- Channel selection - based on the fact at which RxD pin (see the above assignments) first Start+Header Bytes are received
- Full/half duplex selection - based on the Header Byte received

## Bootstrap Loaders (BSL) and User Routines

*Note: For definitions of header/acknowledge byte values exchanged with the host - refer to [Section 23.1.3](#).*

The ASC bootloader functionality includes:

1. enable and configure the both USIC0 communication channels 0 and 1 as follows:
  - a) ASC mode, 8 data bits, 1 stop bit, no parity
2. configure ASC clock-generation circuitry for measurement
3. perform continuously the following sequence for both USIC0 channels one after another
  - a) check either Start zero Byte has been received  
if yes - then:
  - b) reconfigure ASC clock-generating circuitry for normal operation according to the baudrate measured from the Start Byte, then:
  - c) check either Header Byte has been received  
if yes - then:
  - d) check the Header Byte received
    - \* if equal to BSL\_ASC\_F or BSL\_ENC\_F - full duplex mode is selected - continue with step 4.
    - \* if equal to BSL\_ASC\_H or BSL\_ENC\_H - half duplex mode is selected - continue with step 4.
    - \* otherwise - go to sequence for the other channel
4. select the current (Cy) channel for further handling; restore default configuration for the channel C(y-1) which is not selected
5. for the selected channel and mode (full/half duplex) :
  - a) configure TxD pin and ASC transmitter
  - b) adapt (in case) RxD pin settings
  - c) enable transmission, single shot mode
6. check which Header byte was received:
  - a) BSL\_ASC\_F or BSL\_ASC\_H - standard BSL entry sequence was executed, the communication will use further the baudrate detected - continue with **ASC BSL download sequence** (see [Section 23.1.2.2](#))
  - b) BSL\_ENC\_F or BSL\_ENC\_H - the communication during **ASC BSL download sequence** will potentially use different (e.g. higher) baudrate than the initially detected - continue with the **Enhanced ASC BSL entry sequence** (see below))

The above check sequence is executed

- in ASC BSL mode without time-out - until valid Start+Header Bytes are received
- otherwise - only for some time according to BMI.BSLTO

*Note: If mode with time-out is selected but BMI.BSLTO=0 - User mode with start from Flash is directly taken.*



## Bootstrap Loaders (BSL) and User Routines

### Enhanced ASC BSL entry sequence

This is an extension of the standard **ASC BSL entry check sequence** and will be used when higher baudrates are required for the communication channel.

It includes the following steps:

1. Send BSL\_ENC\_ID to acknowledge the establishment of the initial baud rate and entry into enhanced ASC BSL
2. Send current PDIV divider from USIC0\_CHy\_BRG register - the 10-bit value is sent in 2 bytes (most significant byte first)
3. Receive from host the 10-bit value to be written into the STEP bit field in USIC0\_CHy\_FDR register
4. Configure USIC baud rate generator accordingly
5. For the selected channel and mode (full/half duplex):
  - a) Configure TxD pin and ASC transmitter
  - b) Adapt (in case) RxD pin settings
  - c) Enable transmission, single shot mode
6. Send BSL\_BR\_OK to acknowledge the establishment of the new baud rate
7. Receive from host BSL\_BR\_OK to indicate that the communication channel has been successfully established
  - If no or wrong acknowledge value is received, a device software reset will be triggered

**Figure 23-1** shows the outline of the sequence to configure the baud rate.

### Requirements for Host

For the host to support enhanced ASC BSL, the host additionally has to:

- Receive from XMC1200 device, the current 10-bit PDIV value in USIC0\_CHy\_BRG register
- Calculate the MCLK that the device is running on based on the received PDIV through the formula:

(23.1)

$$\text{MCLK} = \text{Initial Baud Rate} \times (\text{PDIV} + 1) \times 8$$

- Select a new baud rate that is supported by the enhanced ASC BSL given the MCLK (see **Table 23-1**)
- Calculate the scaling factor, i.e. ratio of the new baud rate to the initial baud rate. Some examples are given in **Table 23-2**. The scaling factor is rounded to the nearest integer in order to meet a frequency deviation of +/- 3%.

**Bootstrap Loaders (BSL) and User Routines**

**Table 23-1 Supported Baud Rates**

MCLK (MHz)	Standard baud rates supported with ASC BSL (kHz)		Max. baud rate supported with Enhanced ASC BSL (MHz)
	Min.	Max.	
8	1.2	28.8	0.999
16	2.4	57.6	1.998
32	4.8	115.2	3.996

**Table 23-2 Scaling Factor Examples**

Initial standard baud rates (kHz) ---A	Targeted higher baud rates (kHz) ---B	Scaling factor rounded to the nearest integer (B/A)
9.6	1500	156
19.2	1500	78
57.6	1500	26
115.2	1500	13

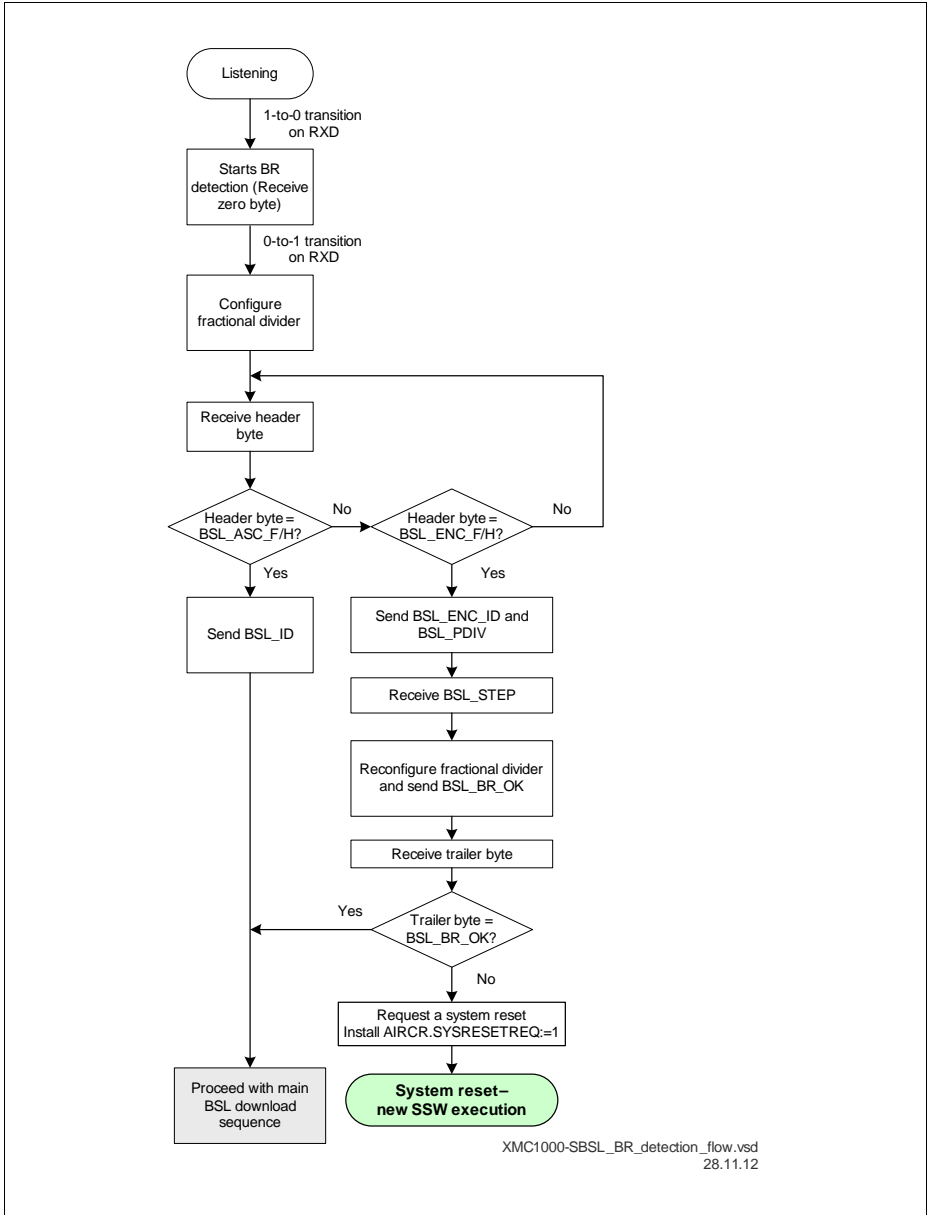
- Calculate the 10-bit value to be written into the STEP bit field of USIC0\_CHy\_FDR register through the formula:

(23.2)

$$\text{STEP (in fractional divider mode)} = \frac{1024 \times \text{Scaling Factor}}{\text{PDIV} + 1}$$

- Send the 10-bit STEP value to the device
- Wait until the BSL\_BR\_OK is received from the device
- Echo the BSL\_BR\_OK back to the device

**Bootstrap Loaders (BSL) and User Routines**



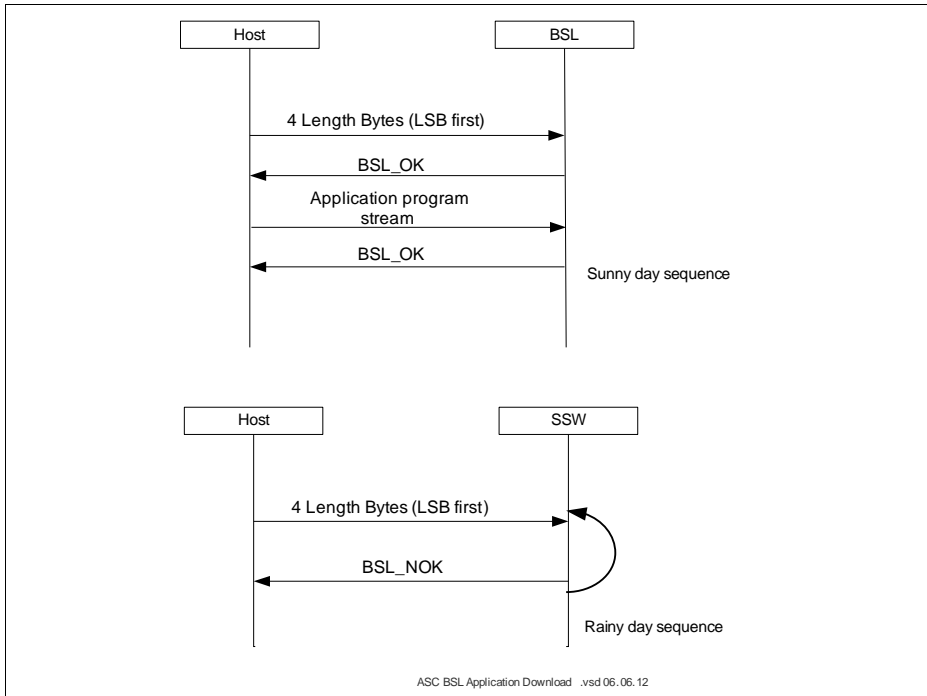
XMC1000-SBSL\_BR\_detection\_flow.vsd  
28.11.12

**Figure 23-1 Baud Rate configuration sequence during XMC1200 ASC BSL entry**

**Bootstrap Loaders (BSL) and User Routines**

**23.1.2.2 ASC BSL download sequence**

After the baud rate has been detected/configured and channel/mode (full/half duplex) selected, ASC BSL awaits 4 bytes describing the length of the application from the host (refer to [Figure 23-2](#)). The least significant byte is received first.



**Figure 23-2 XMC1200 Standard ASC BSL: Application download protocol**

If application length is found alright by SSW, a BSL\_OK byte is sent to the host following which the latter sends the byte stream belonging to the application. After the byte stream has been received, SSW terminates the protocol by sending a final OK byte and then cedes control to the downloaded application.

If application length is found to be in error (application length greater than device SRAM size), a BSL\_NOK byte is transmitted back to the host and the SSW resumes awaiting the length bytes.

**Bootstrap Loaders (BSL) and User Routines**

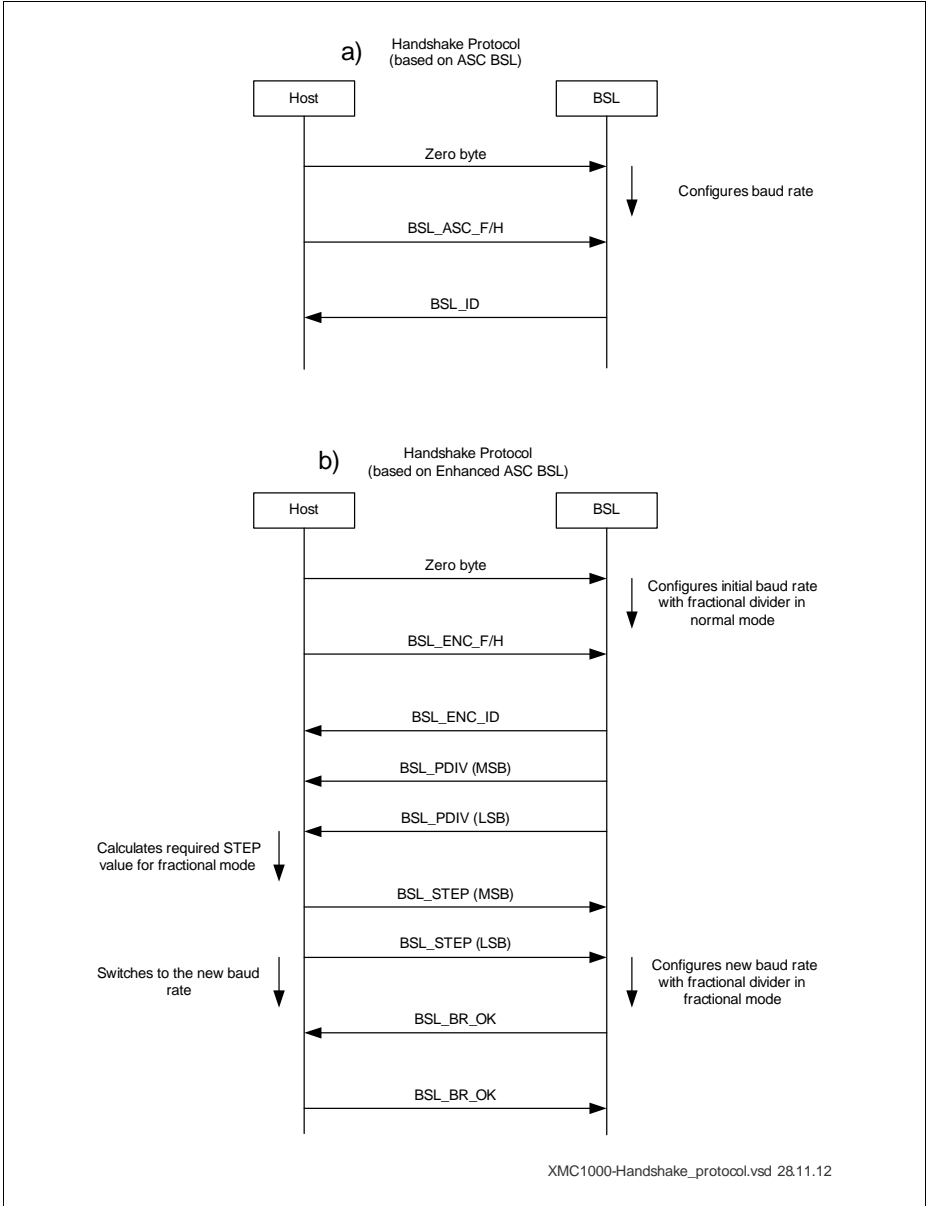
**23.1.3 ASC BSL protocol data definitions**

The interaction between XMC1200 ASC Bootstrap Loader routine and the host implements handshake protocol based on [Figure 23-3](#) and request/acknowledge/data Bytes defined in [Table 23-3](#).

**Table 23-3 Handshake protocol data definitions in XMC1200 ASC BSL**

Name	Length, Byte	Value	Description
Requests/data/acknowledge sent by the Host:			
BSL_ASC_F	1	6CH	Header requesting full duplex ASC mode with the current baud rate
BSL_ASC_H	1	12H	Header requesting half duplex ASC mode with the current baud rate
BSL_ENC_F	1	93 <sub>H</sub>	Header requesting full duplex ASC mode with a request to switch the baud rate
BSL_ENC_H	1	ED <sub>H</sub>	Header requesting half duplex ASC mode with a request to switch the baud rate
BSL_STEP	2	0XXX <sub>H</sub>	10-bit value (LSB aligned) to be programmed into selected USIC channel's FDR.STEP bit field. Most significant 6 bits should contain all 0.
BSL_BR_OK	1	F0 <sub>H</sub>	Final baud rate is established in enhanced ASC BSL
Acknowledges sent by XMC1200 firmware:			
BSL_ID	1	5DH	Start and header bytes are received, baud rate is established
BSL_ENC_ID	1	A2 <sub>H</sub>	Start and header byte(s) are received in enhanced ASC BSL, initial baud rate is established
BSL_PDIV	2	0XXX <sub>H</sub>	10-bit value (LSB aligned) containing the selected USIC channel's BRG.PDIV bit field value. Most significant 6 bits should contain all 0.
BSL_BR_OK	1	F0 <sub>H</sub>	Final baud rate is established in enhanced ASC BSL.
BSL_OK	1	01H	Data received is OK
BSL_NOK	1	02H	Failure encountered during data reception

**Bootstrap Loaders (BSL) and User Routines**



**Figure 23-3 Handshake protocol for XMC1200 ASC BSL entry**

**Bootstrap Loaders (BSL) and User Routines**

## 23.2 SSC Bootstrap loader

This procedure downloads code from a SPI-compatible serial EEPROM into SRAM starting at address 2000'0200H using Channel 0 of USIC0 Module. The length of the code can be arbitrary up to the user-available SRAM size.

XMC1200 is the master SPI-device, following pins are used by the bootloader:

- MRST (master data input) and MTSR (master data output) - on the same P0.15, half-duplex mode used
- SCLK (clock signal) - P0.14, open drain
- SLS (chip-select CS to the EEPROM) - P0.13, open drain

*Note: Due to the specific functionality of the bootloader - performing one Sequential Read operation only - there is no need of a dedicated SLS-control.*

*Note: Due to XMC1200 pin configured as open drain, external pull-up resistors need to be added on the bus*

A SPI-compatible serial EEPROM of type 25xxx must be connected to the pins as above defined. The clock signal is configured at MCLK/10 frequency upon device startup.

The SSC bootloader in XMC1200 is able to communicate with a very broad range on serial-EEPROM types: from such using 8-bit addressing (size up to 2K bit, quite outdated already) up to devices using 24-bit addressing (1M bit and above). The connected EEPROM type is determined by examining the received header bytes, as indicated in

**Table 23-4.**

*Note: Besides the bootloader supports all the device-types, the code/data length which can be downloaded is limited by the size of available SRAM.*

**Table 23-4 SSC BL: Determining the EEPROM Type and data-flow**

SSC Frame	EEPROM with 8-bit addressing connected		EEPROM with 16-bit addressing connected		EEPROM with 24-bit addressing connected		
	N	dat a	P11-send	P11-receive	P11-send	P11-receive	P11-send
1	03 <sub>H</sub>	Read command	XX <sub>H</sub> default level	Read command	XX <sub>H</sub> default level	Read command	XX <sub>H</sub> default level
2	00 <sub>H</sub>	Address	XX <sub>H</sub>	Address_ H	XX <sub>H</sub>	Address_ H	XX <sub>H</sub>
3	00 <sub>H</sub>	dummy	Identification	Address_ L	XX <sub>H</sub>	Address_ M	XX <sub>H</sub>

**Bootstrap Loaders (BSL) and User Routines**

**Table 23-4 SSC BL: Determining the EEPROM Type and data-flow**

SSC Frame	EEPROM with 8-bit addressing connected			EEPROM with 16-bit addressing connected		EEPROM with 24-bit addressing connected	
	Address	Content	Content	Content	Content	Content	Content
4	00 <sub>H</sub>	dummy	Size	dummy	Identification	Address_L	XX <sub>H</sub>
5	00 <sub>H</sub>	dummy	Data Byte 1	dummy	Size, High B	dummy	Identification
6	00 <sub>H</sub>	dummy	Data Byte 2	dummy	Size, Low B	dummy	Size, High B
7	00 <sub>H</sub>	dummy	Data Byte 3	dummy	Data Byte 1	dummy	Size, Mid B
8	00 <sub>H</sub>	dummy	Data Byte 4	dummy	Data Byte 2	dummy	Size, Low B
9	...	dummy	Data Byte 5	dummy	Data Byte 3	dummy	Data Byte 1
...			...n		...n		...n

The EEPROM connected for downloading must contain:

- identification Byte D5H at the first address (0000H)
- the length of the code (Code\_Length) in Bytes as follows:
  - in case of an EEPROM with 8-bit addressing - in one Byte at address 0001H
  - in case of an EEPROM with 16-bit addressing - in two Bytes at addresses 0001H/0002H ordered high/low
  - in case of an EEPROM with 24-bit addressing - in three Bytes at addresses 0001H/0002H/0003H ordered high/middle/low
- the code of defined length follows sequentially

The SSC bootloader functionality includes:

1. enable the communication channel by setting USIC0\_C0\_KSCFG.MODEN:=1
2. assure clock gating for USIC0 module is de-asserted
3. configure the USIC0\_C0 channel as follows:
  - a) SSC mode, 8 data bits, MSB first
  - b) SCLK frequency = MCLK/10
  - c) no SLS activated
  - d) pin-configuration as defined above
  - e) enable transmission
4. de-select EEPROM by setting CS=1
5. enable EEPROM (CS=0) and send Read command (03h)
6. send two zero Bytes to request data from address 0000h
7. Upon any next Byte transfer as long as the EEPROM is still selected (CS=0) - data from then next following address will be read out.
8. the last Byte received is checked:



### Bootstrap Loaders (BSL) and User Routines

- a) if equal to the Identification Byte (D5H) - the EEPROM uses 8-bit addressing:
  - SSW reads one more Byte and saves it as Code\_Length - 1B only effective
  - continue with p.10
- 9. read one more Byte:
  - a) if equal to the Identification Byte (D5H) - the EEPROM uses 16-bit addressing:
    - SSW reads two Bytes in order High/Low to determine Code\_length (2 Bytes)
    - continue with p.10
- 10. read one more Byte:
  - a) if equal to the Identification Byte (D5H) - the EEPROM uses 24-bit addressing:
    - SSW reads three more Bytes in order High/Middle/Low to determine Code\_length (3 Bytes)
    - continue with p.10
  - b) if Not - directly exit the sequence
- 11. check the value of Code\_length:
  - a) if 0 or greater than allowed in XMC1200- directly exit the sequence
- 12. read [Code\_Length] Bytes and store them sequentially from the beginning of SRAM (address 2000'0200H) on
- 13. disable EEPROM (CS=1)
- 14. disable the communication channel by resetting USIC0\_C0\_KSCCFG.MODEN:=0
- 15. set SSW flag BSL\_act=1 and exit the sequence

After the last Byte is received and stored, the Startup Software starts the code downloaded from address 20000'0200H.

### 23.3 Firmware routines available for the user

Several user routines (refer to [Table 23-5](#)) are available inside ROM so they can be called by application software.

**Table 23-5 User routines' in XMC1200 ROM**

XMC1200 ROM		Description
Address	Content	
0000'0100H	_NvmErase	Pointer to <a href="#">Erase Flash Page</a> routine
0000'0104H	_NvmProgVerify	Pointer to <a href="#">Erase, Program &amp; Verify Flash Page</a> routine
0000'0108H	_BmiInstallationReq	Pointer to <a href="#">Request BMI installation</a> routine
0000'010CH	_CalcTemperature	Pointer to <a href="#">Calculate chip temperature</a> routine
0000'0120H	_CalcTSEVAR	Pointer to <a href="#">Calculate target level for temperature comparison</a> routine

**Bootstrap Loaders (BSL) and User Routines**

NVM-related functions (see [Section 23.3.1](#) and [Section 23.3.2](#)) return status indication as shown in [Table 23-6](#).

**Table 23-6 Status indicators returned by NVM routines in XMC1200 ROM**

Status Indicator		Description
Symbolic name	Value	
NVM_PASS	0001'0000H	Function succeeded
NVM_E_FAIL	8001'0001H	Generic error
NVM_E_SRC_ AREA_EXCEEDED	8001'0003H	Source data is not in RAM
NVM_E_SRC_ ALIGNMENT	8001'0004H	Source data is not 4 Byte aligned
NVM_E_DST_ AREA_EXCEEDED	8001'0005H	Destination data is not (completely) located in NVM
NVM_E_DST_ ALIGNMENT	8001'0006H	Destination data is not properly aligned
NVM_E_NVM_FAIL	8001'0009H	NVM module can not be physically accessed
NVM_E_VERIFY	8001'0010H	Verification of the written page not successful

The description below provides an overview of the features.

### 23.3.1 Erase Flash Page

XMC1200 Flash can be erased with granularity of one page = 16 blocks of 16 Bytes = 256 Bytes using this routine.

- Input parameter
  - logical address of the Flash Page to be erased, must be page aligned and in NVM address range (pageAddr)
- Return status (refer to [Table 23-6](#))
  - OK (NVM\_PASS)
  - invalid address (NVM\_E\_DST\_AREA\_EXCEEDED, NVM\_E\_DST\_ALIGNMENT)
  - operation failed (NVM\_E\_FAIL, NVM\_E\_NVM\_FAIL, NVM\_E\_VERIFY)
- Prototype  
NVM\_STATUS XMC1000\_NvmErasePage (unsigned long pageAddr)

### 23.3.2 Erase, Program & Verify Flash Page

This function performs erase (skipped if not necessary), program and verify of selected Flash page.

## Bootstrap Loaders (BSL) and User Routines

- Input parameters
  - logical address of the target Flash Page (dstAddr)
  - address in SRAM where the data starts (srcAddr)
- Return status (refer to [Table 23-6](#))
  - OK (NVM\_PASS)
  - invalid addresses (NVM\_E\_SRC\_AREA\_EXCEEDED, NVM\_E\_SRC\_ALIGNMENT, NVM\_E\_DST\_AREA\_EXCEEDED, NVM\_E\_DST\_ALIGNMENT)
  - operation failed (NVM\_E\_FAIL, NVM\_E\_NVM\_FAIL, NVM\_E\_VERIFY)
- Prototype  
NVM\_STATUS XMC1000\_NvmProgVerify (unsigned long srcAddr, unsigned long dstAddr)

### 23.3.3 Request BMI installation

This procedure initiates installation of a new BMI value. In particular, it can be used as well as to restore the state upon delivery for a device already in User Productive mode.

- Input parameter
  - BMI value to be installed (requestedBmiValue)
- Return status - only upon error, if OK the procedure triggers a reset respectively does not return to calling routine
  - wrong input BMI value (0001H)
- Prototype  
unsigned long XMC1000\_BmiInstallationReq (unsigned short requestedBmiValue)

### 23.3.4 Calculate chip temperature

This procedure calculates the current chip temperature as measured by the XMC1200 built-in sensor, based on data from Flash including trimming values and pre-calculated constants (refer to [Table 23-7](#)) and data from the actual measurement (read from Temperature Sensor Counter2 Monitor Register ANATSEMON).

- Input parameter
  - none
- Return status
  - chip temperature in degree Kelvin
- Prototype  
unsigned long XMC1000\_CalcTemperature (void)

### 23.3.5 Calculate target level for temperature comparison

This procedure - a kind of reverse of [Calculate chip temperature](#) - calculates the value which must be installed in ANATSEVAR register to get indication in ANATSESTATUS.TSE\_CP\_VAR\_STAT bit when the chip temperature is above/below some target/threshold.

**Bootstrap Loaders (BSL) and User Routines**

- Input parameter
  - threshold temperature in degree Kelvin - allowed range 223...423 (temperature)
- Return status
  - equivalent sensor threshold value for the temperature provided as input parameter
- Prototype  
unsigned long XMC1000\_CalcTSEVAR (unsigned long temperature)

**23.4 Data in Flash used by the User Routines**

**Table 23-7** shows the data in Flash which is used by the user routines in XMC1200.

**Table 23-7 Basic Flash data for SSW and user SW in XMC1200**

Address	Length	Function	Target location
Start-up mode selection:			
1000'0E00 <sub>H</sub>	2 B	Boot Mode Index (BMI)	---
1000'0E10 <sub>H</sub>	2 B	Inverse BMI	---
Temperature-sensor related data:			
1000'0F20 <sub>H</sub>	2 B	ANA_TSE_k1	---
1000'0F22 <sub>H</sub>	2 B	ANA_TSE_k3	---
1000'0F24 <sub>H</sub>	4 B	ANA_TSE_k2	---
1000'0F28 <sub>H</sub>	2 B	ANATSEMON_min	---
1000'0F2A <sub>H</sub>	2 B	ANATSEMON_max	---

# **Debug System**

## **24 Debug System (DBG)**

The debug system is an extension to the regular processor architecture. The XMC1200 Series Microcontrollers provide a complete hardware debug solution, with hardware breakpoint and watchpoint options. This allows high system visibility of the processor, memory and available peripherals. The debug functions are implemented with a standard ARM Cortex M0 configuration. Debug functions are integrated into the ARM Cortex-M0 processor architecture. The debug system supports serial wire debug and single pin debug interfacing.

### **References**

- [9] Cortex-M0 Technical Reference Manual
- [10] Cortex-M0 Integration and Implementation Manual
- [11] Cortex-M0 User Guide
- [12] ARMv6-M Architecture Reference Manual
- [13] ARM Debug Interface V5
- [14] CoreSight Components Technical Reference Manual
- [15] CoreSight DAP-Lite

### **24.1 Overview**

The basic debug functionality of the Cortex-M0 debug system is limited to invasive debug and includes processor halt, single step, processor core register access, Reset and HardFault Vector Catch. Besides the hardware debug components unlimited software breakpoints are available. The Debugger can connect to the debug system via the Serial Wire Debug (SWD) or Single Pin Debug (SPD) interface port and uses CoreSight infrastructure and the regular access flow. This permits debugger to identify the processor and its debug capabilities. The debug system allows a full system memory access and access to zero-wait state system slaves via the internal debug access port (DAP) connected to the system bus matrix. This access is non-intrusive and a debugger can access the devices, including memory when the processor is halted or running. Core register full access is available, if the processor is halted. The System Control Space (SCS) provides debug through registers available. The Data Watchpoint Unit (DWT) provides two watchpoint register sets, each implement data address and PC based watchpoint functionality including comparator address masking. The processor BreakPoint Unit (BPU) provides four PC based breakpoint register. The system is accessible by the tool through DAP. DAP permits access to debug resources when the processor is running, halted, or held in reset. A processor enters Debug state if it is

configured to halt on a debug event, and a debug event occurs. The supported debug infrastructure can be identified by checking the ROM table.

### 24.1.1 Features

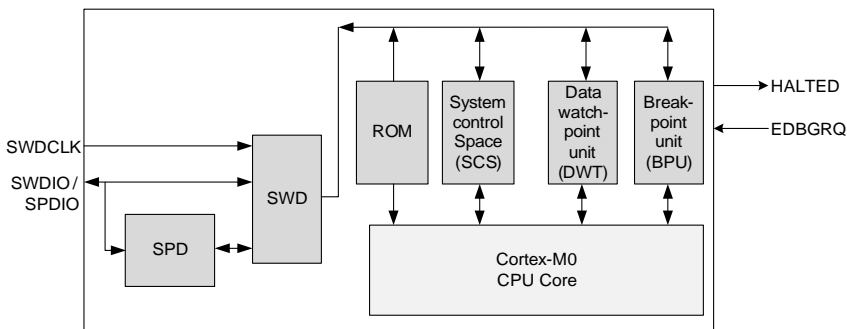
The accurate Debug and Trace System provides the following functionality:

- Serial Wire Debug Port (SWD) provides Serial Wire Debug, which allows to debug via 2 pins.
- Single Pin Debug (SPD) provides a debug capability via 1 pin.
- Processor halt, single-step, processor core register access
- Reset and HaldFault Vector Catch.
- Software breakpoints
- Full system memory access
- 4 Hardware breakpoints supported
- 2 watchpoints supported

*Note: Please refer to [ARMv6-M Architecture Reference Manual](#) for more detailed informations on the debug functionality.*

### 24.1.2 Block Diagram

The Debug system block diagram is shown in [Figure 24-1](#).



**Figure 24-1 Debug and Trace System block diagram**

## 24.2 Debug System Operation

The Debug System provides general debug options. Debug options are based on break points and CPU halt. Debug resources available are Data Watchpoint and Trace, Brakpoint unit, ROM table and the SCS system control block and debug control block. Debug capabilities can be accessed by a debug tool via Serial Wire Debug interface

(SWD) or Single Pin Debug (SPD). The selection of the access protocol (SWD or SPD) is done by BML mode setting.

### **24.2.1 System Control Space (SCS)**

The SCS is the area where the debugger can have direct access to the memory mapped register debug register. The debug resources together with the debug register in the SCS are accessible through the DAP interface. Accessible resources are for example system control and ID registers including system control block. Additionally the system timer and the interrupt controller (NVIC) can be accessed via the SCS.

### **24.2.2 Data Watchpoint and Trace (DWT)**

The DWT unit provides an external Program Counter (PC) sampling capability based on PC sample register and comparators, that support watchpoints for address matching and PC watchpoints for instruction address matching. The PC sampling feature and watchpoint support operate independently of each other and a watchpoint event is asynchronous to the instruction that caused it. The XMC1200 supports two watchpoints, each supporting compare, mask and function registers. Watchpoint events result in a processor halt and enters the processor system into debug state. Data address matching results in a creation of a watchpoint event. Instruction address matching in a creation of a PC watchpoint event. The DWT register are accessible through the DAP interface.

A DWT program counter sample register permits a debugger to periodically sample the PC without halting the processor and allows coarse grained profiling. The PC sampling feature and the watchpoint support operate independently of each other. The register is defined so that a debugger can access it without changing the behavior of any code currently executing on the device.

The recommended mechanism for generating a breakpoint on a single instruction address is to use the BPU. The DWT based mechanism must be used to generate a PC matching event on a range of addresses. The debug return address value for a watchpoint event must be that of an instruction to be executed after the instruction responsible for generating the watchpoint.

### **24.2.3 Break Point Unit (BPU)**

The Breakpoint (BKPT) instruction provides software breakpoints. It can cause a running system to halt depending on the debug configuration. A BKPT is a synchronous debug event, caused by execution of a BKPT instruction or by a match in the BPU. A BKPT causes the processor to enter debug state. The Debug tool can use this situation to investigate the system state when the instruction at a particular address is reached. The BPU provides support for breakpoint functionality on instruction fetches, based on instruction address comparator. The M0 provides four breakpoint comparator registers. Each breakpoint comparator register includes its own enable bit. The comparators match



instruction fetches from the Code memory region and operate only on instruction read accesses. The comparators do not match data read or data write access. Address matching is available on the upper half word, lower half word or both half words. Potential reasons for a debug event are a debug halt, a BKPT, a DWT trap and Vector CATCH.

#### **24.2.4 ROM Table**

To identify the Cortex-M0 processor with the respective Debug System components the debugger locates and identifies the ROM table. ROM table Identification values are predefined and contain pointers to the SCS, BPU and DWT. Each of the debug modules requires its own ROM table and indicate whether the block is present. The ROM table can be accessed through the DAP interface.

#### **24.2.5 Debug tool interface access - SWD**

The tool access based on SWD must use a connection sequence, to ensure that hot-plugging the serial connection does not result in unintentional transfer. The connection sequence ensures that the SWD is synchronized correctly to the header. The sequence consists of a sequence of 50 clock cycles data = 1s. This connection sequences is also used as a line reset sequence. The protocol requires that any run of 50 consecutive 1s on the data input is detected as line reset, regardless of the state of the protocol. After the line reset the debugger reads IDCODE register, which gives confirmation that correct packet frame alignment is has been achieved.

##### **24.2.5.1 SWD based transfers**

The SWD interface requires to continue the clock for a number of cycles after the data phase of any data transfer. This ensures the transfer is completely clocked through the SWD. The transfer completion can be achieved by a immediate start of a new SWD operation, continuous clocking of SWD interface until the host starts a new SWD operation or after the data parity bit the clock is continued for at least 8 more clock rising edges, before stopping the clock.

Each sequence of operation on the serial wire consists of two or three phases and is defined from debugger point of view. The package request and acknowledge response phases are always there. The data transfer phase is only present when either data read or data write request is followed by a valid acknowledge response or the Overrun Detect flag is set.

The SWD protocol applies a simple parity check to all packet request and data transfer phases. On a packet request the parity check is made over the four bit header. On a data transfer the parity check is made over the complete 32 data bits. The parity is added directly after the packet request and after the data transfers. The parity bits are not included in the parity calculation.

## Serial Wire Debug protocol operation

The SWD protocol supports the following operations:

- **Write operation** including OK response (3-Phases: 8-bit write packet request, 3-bit OK ACK, 33-bit data write including 1-bit parity at the end)
- **Read operation** including OK response (3-Phases: 8-bit read packet request, 3-bit OK ACK, 33-bit data read including a 1-bit parity at the end).
- **WAIT response** to read or write operation request (2 Phases: 8-bit read or write packet request, 3-bit WAIT ACK response)
- **FAULT response** Read or Write operation (2-Phases: 8-bit read or write packet request, 3bit FAULT ACK response)
- **Protocol error** sequence occurs when target failed to return a ACK response (1 Phase: 8-bit Packet request - line not driven by target for 32 bit cycles)

*Note: A single-cycle turnaround period between the operation phases is required, for the transfer direction change only. If there is no transfer direction change, no turnaround period is introduced. If the protocol ends with a data transfer towards the debugger a turnaround period is introduced. After the single-cycle turnaround time the protocol must be proceeded.*

### 24.2.5.2 SWD based errors

On the SWD interface protocol errors can occur. These errors might be detected by the parity checks on the data. A message header error can be detected by a parity error. A debugger not receiving a response or a port does not respond to the message, the debugger must back off. During the back off mechanism the debugger does read the IDCODE register and ensures the Debug Port is responsive and then retries the original access.

Errors can be returned by the DAP itself or might come from a debug resource. When an error occurs the error bit remains sticky until cleared. A debugger must check the error status after performing a series of transaction to be aware of an error.

Error conditions within the SWD interface are recorded using sticky flags. Potential errors are read and write errors, overrun detection, protocol errors. When the sticky bit is set to 1 it remains set until it is explicitly cleared to 0. When an error is flagged the current transaction is completed and any additional access port access transaction is discarded until the sticky flag is cleared to 0. A debugger must check periodically the Control/Status register after performing a series of transactions to detect the error.

A read and write error might occur within the DAP or come from the resource being accessed. Additionally a read or write error might be generated if the debugger makes an access port transaction request while the debugger power domain is powered down.

An overrun error might be detected on a sequence of transactions. Therefore the debugger must check after each sequence. The Overrun detection mode can be left by clearing the STICKYORUN and ORUNDETECT.

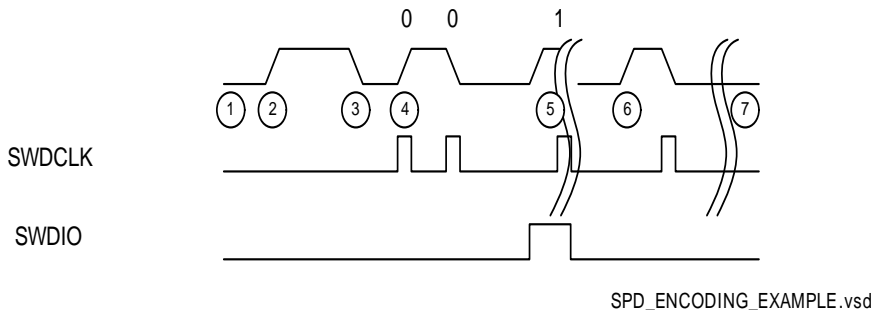
On the Serial Wire Interface protocol errors can occur, for example because of wire-level errors. These errors might be detected by the parity checks of data. If the SWD interface detects a parity error in a message header of the debug message the error is reflected. If the interface does not receive a response to a message, the debugger must back off. It must then requires a read of the IDCODE register, to ensure the debug port is responsive, before retrying the original access, again. If the SWD detects a parity error in the data phase of a write transaction, it sets the sticky write data error flag (WDATAERR) in the control and status register. Subsequent accesses from the debugger, other than IDCODE, CTRL/STAT or ABORT, result in a FAULT response.

#### **24.2.6 Debug tool interface access - Single Pin Debug (SPD)**

The SPD protocol based tool interface access allows to debug the system using a single pin only. The bit frequency is 2 MHz and allows an effective SWD telegram of 1.4 Mbits/s. The protocol is very robust against clock deviations between tool and device.

The SPD protocol encodes the SWD protocol bits with the distance between the SPD signal edges. A SWD value of '0' is encoded with a short distance of 0.5  $\mu$ s, a value of '1' with a distance of 1  $\mu$ s. This encoding is used in both transfer directions. Initially the SPD signal level always start with a positive SPD signal pulse with 1  $\mu$ s width, encoded SPD start bit, which is not part of the SWD protocol. The transmission of the rest of the telegram will be independent of the edge direction. As the protocol starts with a logic one start bit detection it is recommended to finish the protocol with a logic 0 signaling level. If the SPD signal level is high after the last bit of the telegram, that tool to add at '0' bit with a negative edge after 0.5  $\mu$ s. This can be achieved by the tool transferring an odd number of bits.

SWD has a clean request response protocol, where the tool is always the requestor and the device executes and sends a response. So the SWD module will change the direction as defined by the SWD protocol operations ([Section 24.2.5.1](#)).



**Figure 24-2 SPD Encoding Example**

As a basic example a simple transfer is described in Figure before. Initially (1) the SPD module is in IDLE state. During IDLE state the SPD module does not generate a clock to the SWD module. At point (2) the SPD detects a rising edge and moves to a receive state. The first rising edge of the protocol is a start bit for the SPD module only and is not transferred to the SWD module. The following bits are the SWD header information and transferred to the SWD module. At point (5) a logic 1 shown and at (6) a logic zero. At the time the protocol direction is changed (which means for the implementation to go through IDLE state) the clock to SWD is switched off as shown in state (7). The SPD module requires to end on a Low signal value therefore it is required to have an odd number of bits moved into the interface.

### Protocol transfer requirements between SWD and SPD module

The data transfer to and from SWD protocol is single bit based on the SWD clock. The SWD clock is generated by the SPD module and directly derived from the transferred bit. In RECEIVE direction the SPD module transfers the data to the SWD module bit wise, with one clock cycle per bit received.

The SPD module switches off SWD clock when going through module IDLE.

The Debugger adds a SPD start bit in front of the SWD telegram when it writes data to the device (form SPD point of view, RECEIVE). The SPD RECEIVE start bit is not transferred to the SWD module. The RECEIVE start bit is in front of the original SWD protocol on every new RECEIVE start, which is in front of the SWD header and again in front of debugger write data. Additionally the SPD module requires in RECEIVE direction a protocol to end with a logic zero signal level, which is achieved by an odd number of bits transferred by the tool. Based on the SWD protocol this is already achieved in the header phase by adding the described SPD start bit. During acknowledge phase as this phase does have 3 bits only. During the protocol data phase the Debugger has to add one more zero bit. (SPD Start bit, 32-bit data, parity bit, SPD odd bit as logic Zero).

As the SWD protocol requires in RECEIVE direction at least 8 clocks at the end of the data transferred to finish the protocol operation the Debugger has to add 9 logic zeros to the protocol (8 for this requirement and 1 to have an odd number).

### **SPD protocol based tool Interaction**

All SPD communication is initiated by the tool. The tool will send a SWD header encoded to a SPD telegram (header) and then switches the SPD signal direction to input and wait for the acknowledge from the device.

#### **SPD Receive:**

Based on a low level the tool starts the protocol with SPD start bit. The start bit is indicated with a rising edge and a signal duration of 1 $\mu$ s. The following bits are based on the SWD protocol sequence.

The start sequence: SPD start bit + SWD HEADER + 0 Bit + 0 Bit (the two additional 0 bits at the end are required to achieve a low level at the signaling line.).

After receiving the header, the SWD will output his acknowledge response. Thus, SPD will change from RECEIVE to IDLE to SEND and ACKto IDLE again.

Leaving IDLE to RECEIVE state to transfer write data the start bit from tool is also required.

The SPD start bit must be a logic one with the defined time duration of a logic one. Is the signal duration longer it turns into a timeout situation. Is the signal duration shorter the start bit is not recognized.

The debug tool not sending data continuously in SPD RECEIVE direction, generates a Timeout in SPD module, which brings it to IDLE mode again. Starting from IDLE state the tool is required to provide SPD start bit for a new communication. A timeout is recognized after 1.4  $\mu$ s.

A permanent write (SPD RECEIVE) allows to proceed the protocol without SPD start bit. In this case the SPD interface remains in RECEIVE state and only the SWD receive protocol has to be performed. In this case the SWD header has to start with a logic 1 as defined by the SWD protocol.

#### **SPD SEND:**

The tool is required to end a RECEIVE at low level. Based on the low level the SEND start is indicated by a rising edge. SEND has to end with a signal low level, too.

#### **IDLE:**

From RECEIVE to IDLE - driven by SPD or by timeout.

From SEND to IDLE - driven by SWD module caused by direction change .

Time to switch from RECEIVE to SEND is between 375 and 500 ns and always goes through IDLE phase. The tool must change from write (SPD RECEIVE) to read (SPD SEND) direction within 375 ns. SEND always starts with a rising edge.

## 24.2.7 Debug accesses and Flash protection

The XMC1200 Flash implements read protection for sector 0 only. All other sectors can be read. Additionally a user configuration erase and write protection is available, which allows to protect Flash content from unintended writes or erase. Special care is taken, that the debugger can't bypass this protection.

Because of this, per default and after a system reset the debug interface is disabled. The Boot Mode Index (BMI) determines if the debug mode can be entered and the debug interface enabled at the end of the SSW.

Before the BMI is configured to user productive mode a change of BMI to arbitrary value is supported, afterwards BMI can only be restored to its default value, which does not enable debug access.

Besides the BMI configuration the Debug system supports a protection mechanism which prevents a debug access to the system address area during the time startup software (SSW) is running. Firmware controls the debug access, based on register setting.

Software based Breakpoints are supported, but prevented during SSW.

## 24.2.8 Halt after reset

There are two possibilities to perform a halt after reset. The first possibility is Infineon specific and allows to perform a CPU halt after "power on"/"master" reset (HAR) at the very first instruction of the Application code. The HAR activation is based on BMI settings and SSW executing endless loop, allowing a debugger to take control over the device. A defined configuration sequence driven by the connected debug tool is required in this case. The second possibility is the regular ARM flow halt after reset, which is based on breakpoints and a system reset. This halt after reset is also named "Warm Reset". In both cases the ARM system can not be accessed for security reasons from the debug port during the time SSW is running, as the physical pins are not available during that time. Based on the BMI setting the debug capability can be enabled at the end of the SSW by firmware. The default BMI configuration does not enable debug access.

### 24.2.8.1 HAR

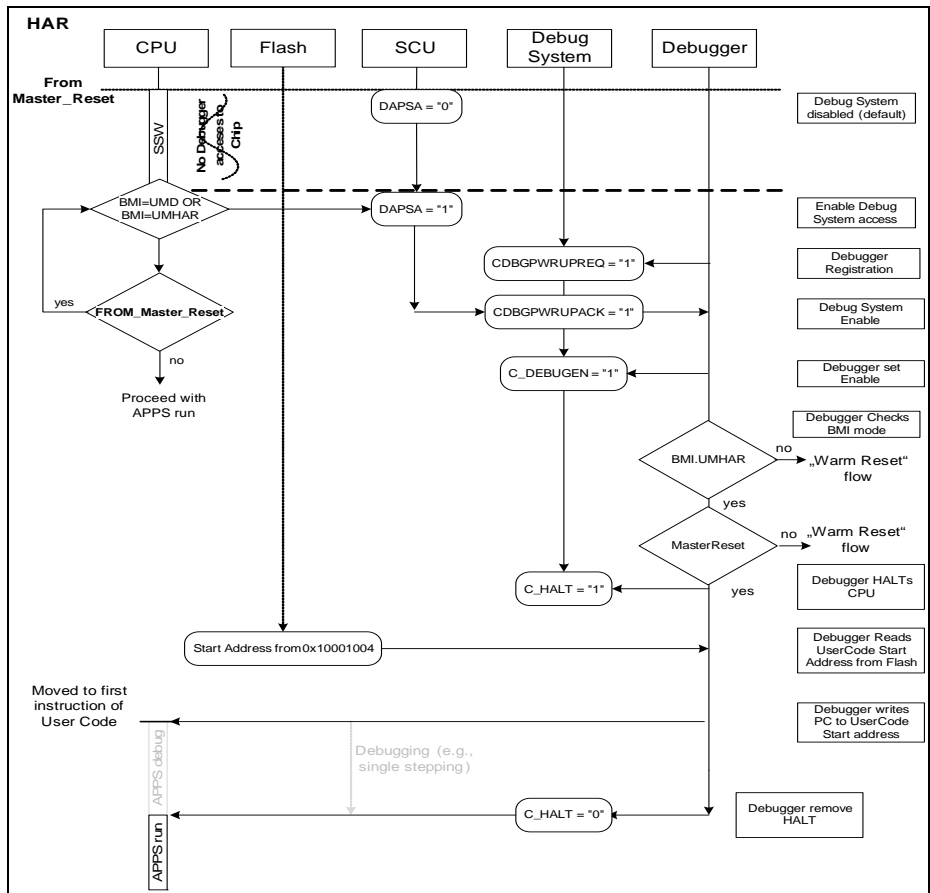
The BMI can be configured to allow a HAR (UMHAR) at the end of the SSW, which always requires a power on reset to be executed. A new BMI configuration to BMI.UMHAR (User Mode with debug enabled and HAR) requires to perform a master reset to boot in UMHAR mode.

At a HAR (Cold Reset situation), the system comes from a PORST (or Master Reset) . To achieve a HAR, the tool has to register (CDBGPWRUPREQ) and enable (DHSCR.C\_DEBUGEN) the debug system. Additionally it has to halt (DHCSR.C\_HALT) the CPU and manipulate the PC (Program Counter) to point to the start address of the user code. The debugger registration and debug system enable is possible at the end of

**Debug System (DBG)**

the firmware, where firmware is waiting for a tool registration. During SSW execution the debugger as no access capability and cannot set the enabling bits CDBGPWRUPREQ, C\_DEBUGEN or halt the CPU. The address of the user code start address can be read from address 0x10001004 in user Flash. It is recommended to check the Boot Mode Index BMI.HWCFG bit for UMHAR before manipulating the PC.

The following Figure (Figure HAR - Halt After Reset) shows the software flow based on the modules participating to the HAR.



**Figure 24-3 HAR - Halt After Reset Flow**

### 24.2.8.2 Warm Reset

A halt after system reset (Warm Reset) can be achieved by programming a break point at the first instruction of the application code. Additionally the CDBGPWRUPREQ (tool registration) and the C\_DEBUGEN has to be set by the debugger. After a system reset, the HAR situation is not considered, as the reset is not coming from PORST (Master\_Reset).

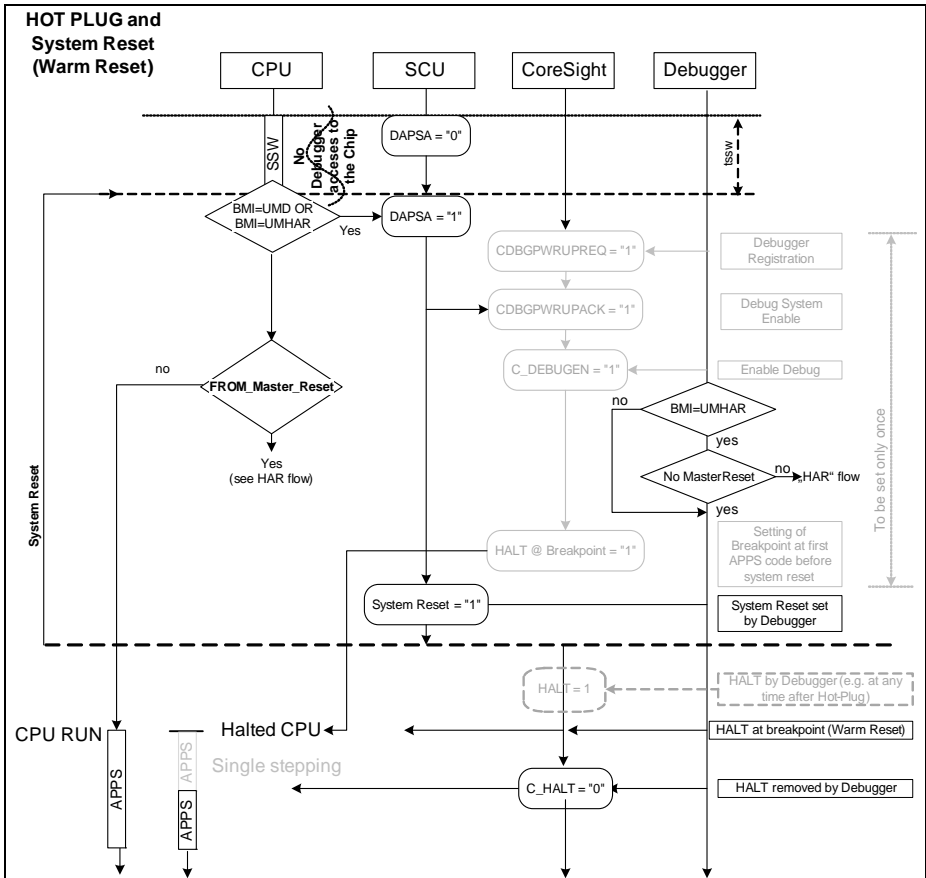
*Note: The CDBGPWRUPREQ and C\_DEBUGEN does not have to be set after a system reset, if they have already been set before and the debugger remains registered. The bits are not affected by the system reset.*

A tool hot plug situation allows to debug the system by enabling the CDBGPWRUPREQ and the C\_DEBUGEN register. It is recommended to check the Boot Mode Index BMI.HWCFG. The Warm Reset flow can be done in both BMI modes, UMD (User mode with debug enabled) and UMHAR. In both cases the “Warm Reset” flow is based on breakpoint setting and system reset afterwards.

In general after a tool hot plug break points can be set or the CPU can directly be HALTED and stops at the actual program stage. To stop at the very first instruction of the user code the tool has to fire a system reset after setting the breakpoint there.

The following Figure (Figure Hot Plug and Warm Reset) illustrates the debug tool HOT PLUG situation or the Halt after Warm Reset (system reset) and how to proceed to come to a Halt situation.





**Figure 24-4 HOT PLUG or Warm Reset Flow**

### 24.2.9 Halting Debug and Peripheral Suspend

The XMC1200 device supports a suspend capability for peripherals, if the program execution of the CPU is stopped by the debugger, e.g. with a breakpoint, or with the C\_HALT. This allows to debug critical states of the whole microcontroller. Whether the suspend function is supported or not has to be configured locally at the peripheral.

In some cases it is important to keep certain peripherals running, e.g. a PWM or a CAN node, to avoid system errors or even critical damage to the application. Because of this, the peripheral allows to configure how it behaves, when the CPU enters halt debug

mode. Per default a peripheral is not sensitive on a suspend request. Sensitivity can be configured based on the system use case.

It can be decided at the peripheral to support a Hard Suspend or a Soft Suspend. At a Hard Suspend situation the clock at the peripheral is switched off immediately, without waiting on acknowledge from the module. At a soft suspend the peripheral can decide when to suspend. Usually at the end of the actual active transfer.

A Watchdog timer is only running when the suspend bus is not active. This is particularly useful as it can't be serviced by a halted CPU. A configuration option is available, which allows to enable the Watchdog timer also during suspend. This allows to debug Watchdog behavior, if a debugger is connected.

The user has to ensure, that always only those peripherals are sensitive to suspend, which are intended to be. To address this, each peripheral supporting suspend does have an enable register which allows to enable the suspend feature. The following table ([Table 24-1](#)) shows the peripherals, supporting or not supporting peripheral suspend or detailed information on the peripheral suspend behavior during soft suspend can be found at the respective peripheral chapter.

**Table 24-1 Peripheral Suspend support**

Peripheral	supported	default mode	Hard Suspend	Soft Suspend
RTC	yes	not active	yes	no
USIC	yes	not active	no	yes
CCU4	yes	not active	yes	yes
BCCU	yes	not active	yes	no
WDT	yes	active	yes	no
VADC	yes	not active	yes	yes
LEDTS	yes	not active	yes	no
PRNG	no	- - -	- - -	- - -

*Note: Enable debug suspend function in the user initialization code after every reset. In addition the user has to consider debug suspend register at peripherals can only be configured after the clock of the module is enabled via CGATCLR0 register.*

**Important tool provider note:**

The peripheral suspend logic is connected to the system reset. A system reset activation results in a peripheral suspend configuration loss. Therefore the suspend configuration at the peripherals “outlasting” a system reset, requires the tool to reconfigure the suspend configuration after system reset. This is achieved by shadowing the user peripheral suspend configuration in the tool and set a HW breakpoint at the first

**Debug System (DBG)**

instruction of use code, if the suspend function is activated. After the CPU halts at that breakpoint the tool has to reconfigure the suspend configuration at the peripheral, as it has been configured before the system reset.

*Note: Suspend activation results in losing one HW breakpoint, as it is used by the tool to handle the suspend reconfiguration after system reset.*

A debug tool should offer the peripheral suspend reconfiguration after system reset with an option to proceed Usercode without an user interaction requirement after tool reconfiguration or remain stopped at first line of user code and wait for user action.

(The user configures the desired suspend behavior only once and the tool stores the configuration to have it present for a automatic reconfiguration after a system reset.)

**24.2.10 Debug System based processor wake-up**

The debugger can wake-up a processor in sleep mode (sleep and deep sleep mode). The wake-up is based on a new pending interrupt event from the debug system, which is a HALT. The interrupt event does also wake-up the processor, if the interrupt is disabled or has insufficient priority to cause exception entry. The interrupt wake-up mode is derived by the NVIC (Programmable Multiple Priority Interrupt System) available in the processor system. The debugger is able to register, enable the Debug System and HALT the CPU also in sleep and deep sleep mode.

*Note: The wake-up from deep-sleep mode via debugger halt is only supported using SWD interface. A wake-up from deep-sleep based on SPD interface is not supported.*

**24.2.11 Debug Access Server (DAS)**

The DAS API provides an abstraction of the physical device interface for tool access. The key paradigm of DAS is to read or write data in one or several address spaces of the target device.

**DAS Features**

- Standard interface for all types of tools
- Efficient and robust methods for data transfer
- Several independent tools can share the same physical interface
- Infineon's DAS miniWiggler support SWD and SPD.

*Note: DAS is not XMC1200 specific. It can be used for all Infineon 8-, 16, and 32-bit microcontrollers with DAP, SWD, SPD or JTAG interface. For more information refer to [www.infineon.com/DAS](http://www.infineon.com/DAS).*

## 24.2.12 Debug Signals

XMC1200 MC product family provides debug capability using ARM M0 Debug port SWD or the Infineon proprietary SPD. The SWD Port has 2 interface signals (Clock + Bidirectional data). The SPD port has one interface signal (SPDIO - bidirectional data) with an overlay of SWD interface SWDIO pin.

**Table 24-2 SWD toplevel IO signal**

Signal	Direction	Function
SWDCLK	I	Serial Wire Clock. This pin is the clock for debug module when running in Serial Wire debug mode.
SWDIO	I / O	Serial Wire debug data IO. Used by an external debug tool to communicate with and control the Cortex-M0 debug system.

The HALTED and EDBGQR signals can be used to halt the CPU based on an external event. This allows to halt an external hardware synchronously with the CPU. The halt can be recognized by the external hardware based on the HALTED output. This can be used for example to synchronize with an logic analyzer and request a breakpoint or in a multi CPU scenario.

### 24.2.12.1 Internal pull-up and pull-down on SWD/SPD pins

It is a requirement to ensure none floating SWD/SPD input pins, as they are directly connected to flip-flops controlling the debug function. To avoid any uncontrolled I/O voltage levels internal pull-up and pull-downs on SWD/SPD input pins are provided.

- SWDIO/SPD: Internal pull-up
- SWCLK: Internal pull-down

## 24.2.13 Reset

The debug system register bits are reset by Power-on reset. Other reset in the system do not have an effect on the debug register, if the tool is registered.

## 24.3 Debug System Power Save Operation

The Debug System is in the “always-on” power domain, which allows to connect the debugger to the device. The Debug System does not support any special power mode or power save operation. The power supply of the Debug System is directly connected to the main chip part including the system components.

## 24.4 Service Request Generation

The debugger can set `DHCSR.C_MASKINTS` to 1 to prevent `PendSV`, `SysTick` and external configured interrupts from occurring.

## 24.5 Debug behavior

The Debug System is based on events. Whereas events are an entry to debug state, if halting debug is enabled. Debug events available are:

- Internal halt request
- Breakpoint
- Watchpoint
- Vector catch
- External debug request based on

The following events are synchronous debug events:

- Breakpoint debug events, caused by execution of a `BKPT` instruction
- Breakpoint debug events, caused by execution of a match in the BPU
- Vector catch debug events
- Step debug events (`DHCSR.C_STEP`)

The following events are asynchronous debug events:

- Watchpoint debug events, including PC match watchpoints
- Halt request debug event (`DHCSR.C_HALT`)
- External signal based debug request event (`EDBGRQ` signal)

Asynchronous debug events do have a lower prioritization than synchronous generated events. An instruction can generate a number of synchronous debug events. It also can generate a number of asynchronous exceptions.

The Debug Fault Status register (`DFSR`) contains a status bit for each debug event. The bits are write-one-to-clear. These bits are set to 1 when a debug event causes the processor to halt or generate an exception. The bits are also updated if the event is ignored.

Software must write `0xA05F` to the `DHCSR.DBGKEQ` register in order to be able to have debug support available from CPU side.

## 24.6 Power, Reset and Clock

The requirements for power, reset and clock are derived from ARM.

### 24.6.1 Power management

There is no power management implemented for the debug system. . Nevertheless the tool does has to follow the regular tool flow by setting the CDBGPWRUPREQ in order to register the tool.

### 24.6.2 Debug System reset

The SWD register are in the power on reset (PORST) domain.

The Debug logic is reset by system reset, if no tool is connected to chip and therefore not registered, which is indicated by **CDBGPWRUPREQ** not set.

#### Processor reset

A processor or warm reset (SYSRESETn) initializes the majority of the processor, excluding debug logic, BKPT unit, DWT unit and SCS.

#### PowerOn reset

PORESETn reset initializes the SWD access port, the AHB-AP logic and all other debug system related functions.

#### Normal operation

During normal operation the resets PORESETn and SYSRESETn are deasserted.

### Processor reset affects Debug System

A System reset also affects the Debug System, if a tool is not registered. The tool registration is reflected by an activation of the register bit CDBGPWRUPACK, which activates by a debugger enabling the CDBGPWRUPREQ. .

### 24.6.3 Debug System Clocks

The Debug system clock is called DCLK and is derived directly from SCLK (free running clock). DCLK must always be driven while a debugger is connected.

## 24.7 Initialization and System Dependencies

### 24.7.1 ID Codes

The following sub chapters describes the available IDs.

#### 24.7.1.1 CPUID

CPUID is 410CC200<sub>H</sub>.

### 24.7.1.2 ROM Table

The DAP controller comes with the default ARM JTAG IDs defined by the IDCODE. This value is: 0BB11477<sub>H</sub> for SW-DP.

The JEP106 ID is defined by the JEDEC Standard for Infineon as C1<sub>H</sub>

To identify Infineon as manufacturer and identify XMC1200 by it's device ID, a ROM table is added. A 4 k memory block in system memory is defined, which contains the IDs.

The CortexM0 ROM table is located at 0xE00F\_F000 and is defined with the following values:

- M0 ROM table, at 0xE00F\_F000 - PID JEP106: 0x3B/0x4; part# = 471
- Data Watchpoint/Trace, at 0xE000\_1000: PID JEP106: 0x3B/0x4; part# = 0x008
- Breakpoint Unit, at 0xE000\_2000: PID JEP106 = 0x3B/0x4; part# = 0x00B

The format of the ROM table is illustrated in [Table 24-3](#).

**Table 24-3 PID Values of XMC1200 ROM Table**

Name	Offset	Description	Reference
PID0	FE0 <sub>H</sub>	Peripheral ID0	Part Number [7:0]
PID1	FE4 <sub>H</sub>	Peripheral ID1	bits [7:4] JEP106 ID code [3:0] bits [3:0] Part Number [11:8]
PID2	FE8 <sub>H</sub>	Peripheral ID2	bits [7:4] Revision bit [3] == 1: JEDEC assigned ID fields bits [2:0] JEP106 ID code [6:4]
PID3	FEC <sub>H</sub>	Peripheral ID3	bits [7:4] RevAnd, minor revision field bits [3:0] if non-zero indicate a customer-modified block
PID4	FD0 <sub>H</sub>	Peripheral ID4	bits [7:4] 4KB count bits [3:0] JEP106 continuation code

The ROM table values representing Infineon Part Number, JEP106 and Revision number can be checked in the SCU chapter.

## 24.8 Debug System Registers

### Registers Overview

The absolute register address is calculated by adding:

The DWT, BPU, ROM table, DCB and debug register in the SCS are accessible memory mapped by the debugger and also from the CPU.

**Table 24-4 Registers Address Space**

Module	Base Address	End Address	Note
DWT	E000 1000 <sub>H</sub>	E000 1FFF <sub>H</sub>	Data Watchpoint
BP	E000 2000 <sub>H</sub>	E000 2FFF <sub>H</sub>	Breakpoint Unit
SCS	E000 E000 <sub>H</sub>	E000 EFFF <sub>H</sub>	SCS (here DBG CTRL)
ROM	E00F F000 <sub>H</sub>	E00F FFFF <sub>H</sub>	ROM table area

**Table 24-5 Register Overview**

Short Name	Description	Offset Addr.	Access Mode		Description See
			Read	Write	
SCS_DFSR	Debug Fault Status Register	D30 <sub>H</sub>			<a href="#">Page 24-20</a>
SCS_DHCSR	Debug Halting Control and Status Register	DF0 <sub>H</sub>			<a href="#">Page 24-22</a>
SCS_DCRSR	Debug Core Register Selector Register	DF4 <sub>H</sub>			<a href="#">Page 24-28</a>
SCS_DCRDR	Debug Core Register Data Register	DF8 <sub>H</sub>			<a href="#">Page 24-29</a>
SCS_DEMCR	Debug Exception and Monitor Control Register	DFC <sub>H</sub>			<a href="#">Page 24-30</a>
DWT_CTRL	DWT Control Register	000 <sub>H</sub>			<a href="#">Page 24-31</a>
DWT_PCSR	DWT program Counter Sample Register	01C <sub>H</sub>			<a href="#">Page 24-32</a>
DWT_COMP0	DWT Comparator register	020 <sub>H</sub>			<a href="#">Page 24-32</a>
DWT_COMP1	DWT Comparator register	030 <sub>H</sub>			<a href="#">Page 24-32</a>
DWT_MASK0	DWT MASK register	024 <sub>H</sub>			<a href="#">Page 24-33</a>
DWT_MASK1	DWT MASK register	034 <sub>H</sub>			<a href="#">Page 24-33</a>



**Table 24-5 Register Overview (cont'd)**

Short Name	Description	Offset Addr.	Access Mode		Description See
			Read	Write	
DWT_FUNCTION0	DWT Comparator Function register	028 <sub>H</sub>			<a href="#">Page 24-34</a>
DWT_FUNCTION1	DWT Comparator Function register	038 <sub>H</sub>			<a href="#">Page 24-34</a>
BP_CTRL	Breakpoint Control register	000 <sub>H</sub>			<a href="#">Page 24-35</a>
BP_COMP0	Breakpoint Comparator register	008 <sub>H</sub>			<a href="#">Page 24-36</a>
BP_COMP1	Breakpoint Comparator register	008C			<a href="#">Page 24-36</a>
BP_COMP2	Breakpoint Comparator register	010 <sub>H</sub>			<a href="#">Page 24-36</a>
BP_COMP3	Breakpoint Comparator register	014 <sub>H</sub>			<a href="#">Page 24-36</a>

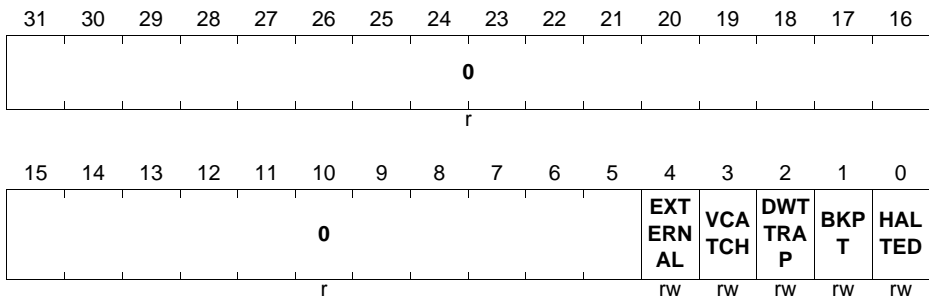
### 24.8.1 DFSR - Debug Fault Status Register

#### SCS\_DFSR

The DFSR registers provides the top level reason why a debug event has occurred. Writing 1 to a register bit clears the bit to 0. A read of the HALTED bit by an instruction executed by stepping returns an UNKNOWN value.

#### SCS\_DFSR

**Debug Fault Status Register (D30<sub>H</sub>)** **Reset Value: 0000 0000<sub>H</sub>**



Field	Bits	Type	Description
HALTED	0	rw	<b>HALTED</b> Indicates a debug event generated by a C_HALT or C_STEP request, triggered by a write to the DHCSR. 0 <sub>B</sub> no active halt request debug event. 1 <sub>B</sub> halt request debug event active.
BKPT	1	rw	<b>BKPT</b> Indicates a debug event generated by BKPT instruction execution or a breakpoint match in the BPU. 0 <sub>B</sub> no breakpoint debug event. 1 <sub>B</sub> at least one breakpoint debug event.
DWTTRAP	2	rw	<b>DWTTRAP</b> Indicates a debug event generated by the DWT. 0 <sub>B</sub> no debug events generated by the DWT. 1 <sub>B</sub> at least one debug event generated by the DWT.
VCATCH	3	rw	<b>VCATCH</b> Indicates whether a vector catch debug event was generated. 0 <sub>B</sub> no vector catch debug event generated. 1 <sub>B</sub> vector catch debug event generated. <i>Note: The corresponding</i>
EXTERNAL	4	rw	<b>EXTERNAL</b> Indicates an asynchronous debug event generated because of EDBGQRQ being asserted. 0 <sub>B</sub> no EDBGQRQ debug event. 1 <sub>B</sub> EDBGQRQ debug event.
0	[31:5]	r	<b>Reserved</b>

## 24.8.2 DHCSR - Debug Halting Control and Status Register

### SCS\_DHCSR

Controls halting debug. When C\_DEBUGEN is set to 1, C\_STEP and C\_MASKINTS must not be modified when the processor is running (S\_HALT is 0 when the processor is running). When C\_DEBUGEN is set to 0, the processor ignores the values of all other bits in this register.

**Debug System (DBG)**

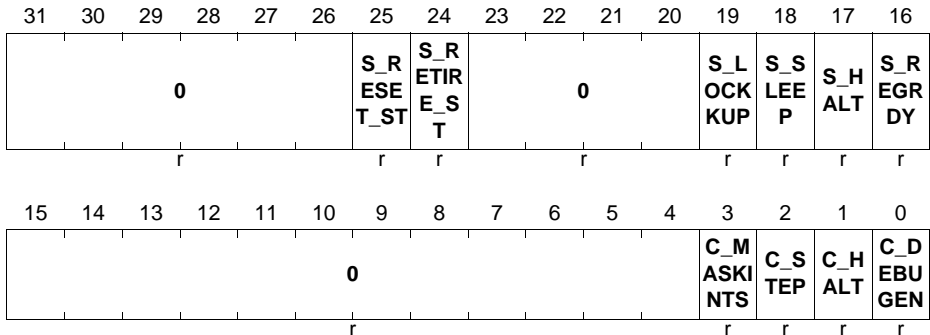
A separate register is represented below for read and write as the function changes at some bits access based.

**SCS\_DHCSR**

**Debug Halting Control and Status Register [Read Mode]**

(DF0<sub>H</sub>)

Reset Value: 0000 0000<sub>H</sub>



Field	Bits	Type	Description
<b>C_DEBUGEN</b>	0	r	<p><b>Halting debug enable bit</b></p> <p>0<sub>B</sub> Halting debug disabled. 1<sub>B</sub> Halting debug enabled.</p> <p><i>Note: If a debugger writes to DHCSR to change the value of this bit from 0 to 1, it must also write 0 to the C_MASKINTS bit, otherwise behavior is UNPREDICTABLE. This bit can only be written from the DAP Access to the DHCSR from Software running on the processor it cannot be set. This bit is 0 after Power-on reset.</i></p>
<b>C_HALT</b>	1	r	<p><b>Processor halt bit.</b></p> <p>The effects of writes to this bit are:</p> <p>0<sub>B</sub> Request a halted processor to run. 1<sub>B</sub> Request a running processor to halt.</p> <p><i>Note: This bit is unknown after power-on reset</i></p>

Field	Bits	Type	Description
<b>C_STEP</b>	2	r	<p><b>Processor step bit.</b></p> <p>The effects of writes to this bit are:</p> <p>0<sub>B</sub> Single-stepping disabled.</p> <p>1<sub>B</sub> Single-stepping enabled.</p> <p><i>Note: This bit is unknown after power-on reset</i></p>
<b>C_MASKINTS</b>	3	r	<p><b>Mask PEDSV, SysTick and external configurable interrupts.</b></p> <p>The effects of writes to this bit are:</p> <p>0<sub>B</sub> Do not mask</p> <p>1<sub>B</sub> Mask PendSV, SysTick and external configurable interrupts.</p> <p>The effect of any attempt to change the value of this bit is UNPREDICTABLE unless both:</p> <ul style="list-style-type: none"> <li>• before the write to DHCSR, the value of the C_HALT bit is 1</li> <li>• the write to the DHCSR that changes the C_MASKINTS bit also writes 1 to the C_HALT bit.</li> </ul> <p>This means that a single write to DHCSR cannot set the C_HALT to 0 and change the value of the C_MASKINTS bit.</p> <p>When DHCSR.C_DEBUGEN is set to 0, the value of this bit is UNKNOWN.</p> <p>This bit is UNKNOWN after Power-on reset.</p>
<b>S_REGRDY</b>	16	r	<p><b>S_REGRDY status - a handshake flag for transfers through DCRDR</b></p> <p>How to work with:</p> <ul style="list-style-type: none"> <li>• Writing to DCRSR clears the bit to 0.</li> <li>• Completion of the DCRDR transfer then sets the bit to 1</li> </ul> <p>Check DCRDR for more information.</p> <p>0<sub>B</sub> There has been a wrote to the DCRDR, but the transfer is not complete.</p> <p>1<sub>B</sub> The transfer to or from the DCRDR is complete.</p> <p><i>Note: This bit is only valid when the processor is in Debug State, otherwise the bit is UNKONWN.</i></p>

**Debug System (DBG)**

Field	Bits	Type	Description
<b>S_HALT</b>	17	r	<p><b>S_HALT indicates whether the processor is in Debug state.</b></p> <p>0<sub>B</sub> Not in Debug State. 1<sub>B</sub> In Debug State.</p>
<b>S_SLEEP</b>	18	r	<p><b>S_SLEEP indicates whether the processor is sleeping.</b></p> <p>0<sub>B</sub> Not sleeping. 1<sub>B</sub> Sleeping.</p> <p><i>Note: The debugger must set the DHCSR.C_HALT bit to 1 to gain control, or wait for an interrupt or other wake-up event to wake-up the system.</i></p>
<b>S_LOCKKUP</b>	19	r	<p><b>S_LOCKUP indicates whether the processor is locked up because of an unrecoverable exception.</b></p> <p>0<sub>B</sub> Not locked up. 1<sub>B</sub> Locked up.</p> <p><i>Note: This bit is only read as 1 when accessed by a remote debugger using the DAP. The value of 1 indicates that the processor is running, but locked up due to an unrecoverable exception case.</i></p>

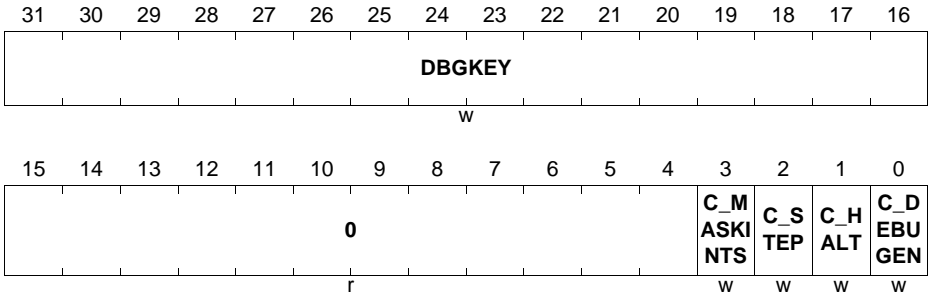
Field	Bits	Type	Description
<b>S_RETIRE_ST</b>	24	r	<p><b>S_RETIRE_ST - When not in Debug state, indicates whether the processor has completed the execution of an instruction since the last read of DHCSR:</b></p> <p>0<sub>B</sub> No instruction has completed since the last DHCSR read.</p> <p>1<sub>B</sub> At least one instructions has completed since last DHCSR read.</p> <p>This is a sticky bit, that clears to 0 on a read of DHCSR.</p> <p>This bit is UNKNOWN:</p> <ul style="list-style-type: none"> <li>• after a Local reset, but is set to 1 as soon as the processor completes execution of an instruction</li> <li>• when S_LOCKUP is set to 1</li> <li>• when S_HALT is set to 1</li> </ul> <p><i>Note: When the processor is not in Debug state, a debugger can check this bit to determine if the processor is stalled on a load store or fetch access.</i></p>
<b>S_RESET_ST</b>	25	r	<p><b>S_RESET_ST indicates whether the processor has been reset since the last read of DHCSR.</b></p> <p>0<sub>B</sub> No reset since last DHCSR read.</p> <p>1<sub>B</sub> At least one rest since last DHCSR read.</p> <p><i>Note: This is a sticky bit, that clears to 0 on a read of DHCSR.</i></p>
<b>0</b>	[15:4], [23:20], [31:26]	r	<b>Reserved</b>

**SCS\_DHCSR**

**Debug Halting Control and Status Register [Write Mode]**

(DF0<sub>H</sub>)

Reset Value: 0000 0000<sub>H</sub>



Field	Bits	Type	Description
<b>C_DEBUGEN</b>	0	w	<p><b>Halting debug enable bit</b></p> <p>0<sub>B</sub> Halting debug disabled. 1<sub>B</sub> Halting debug enabled.</p> <p><i>Note: If a debugger writes to DHCSR to change the value of this bit from 0 to 1, it must also write 0 to the C_MASKINTS bit, otherwise behavior is UNPREDICTABLE. This bit can only be written from the DAP Access to the DHCSR from Software running on the processor it cannot be set. This bit is 0 after Power-on reset.</i></p>
<b>C_HALT</b>	1	w	<p><b>Processor halt bit.</b></p> <p>The effects of writes to this bit are:</p> <p>0<sub>B</sub> Request a halted processor to run. 1<sub>B</sub> Request a running processor to halt.</p> <p><i>Note: This bit is unknown after power-on reset</i></p>
<b>C_STEP</b>	2	w	<p><b>Processor step bit.</b></p> <p>The effects of writes to this bit are:</p> <p>0<sub>B</sub> Single-stepping disabled. 1<sub>B</sub> Single-stepping enabled.</p> <p><i>Note: This bit is unknown after power-on reset</i></p>

Field	Bits	Type	Description
<b>C_MASKINTS</b>	3	w	<p><b>Mask PEDSV, SysTick and external configurable interrupts.</b></p> <p>The effects of writes to this bit are:</p> <p>0<sub>B</sub> Do not mask 1<sub>B</sub> Mask PendSV, SysTick and external configurable interrupts.</p> <p>The effect of any attempt to change the value of this bit is UNPREDICTABLE unless both:</p> <ul style="list-style-type: none"> <li>before the write to DHCSR, the value of the C_HALT bit is 1</li> <li>the write to the DHCSR that changes the C_MASKINTS bit also writes 1 to the C_HALT bit.</li> </ul> <p>This means that a single write to DHCSR cannot set the C_HALT to 0 and change the value of the C_MASKINTS bit.</p> <p>When DHCSR.C_DEBUGEN is set to 0, the value of this bit is UNKNOWN.</p> <p>This bit is UNKNOWN after Power-on reset.</p>
<b>DBGKEY</b>	[31:16]	w	<p><b>DEBUG Key Bits [31:16]!!!</b></p> <p>Software must write <b>0xA05F</b> to this field to enable write access to bits [15:0], otherwise the processor ignores the write access</p>
<b>0</b>	[15:4]	r	<b>Reserved</b>

### 24.8.3 DCRSR - Debug Core Register Selector Register

#### SCS\_DCRSR

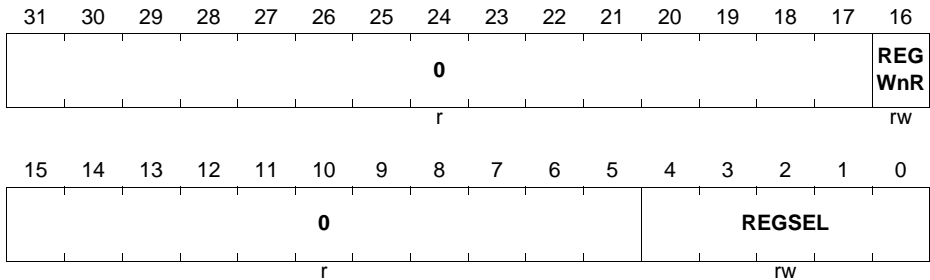
The DCRSR together with DCRDR (Debug Core Register Data Register) provides debug access to the ARM core register and special-purpose registers. A write to DCRSR specifies the register to transfer, whether the transfer is a read or a write, and starts the transfer. This register is only accessible in Debug state.



**SCS\_DCRSR**

**Debug Core Register Selector Register (DF4<sub>H</sub>)**

**Reset Value: 0000 0000<sub>H</sub>**



Field	Bits	Type	Description
<b>REGSEL</b>	[4:0]	rw	<p><b>REGSEL - Specifies the ARM core register or special-purpose register to transfer</b></p> <p>00000<sub>B</sub>- 01100<sub>B</sub> ARM core register R0-R12. For example, 0b00000 specifies R0 and 0b00101 specifies R5</p> <p>01101<sub>B</sub> The current SP. See also values 0b10001 and 0b10010.</p> <p>01110<sub>B</sub> LR.</p> <p>01111<sub>B</sub> Debug Return Address.</p> <p>10000<sub>B</sub> xPSR.</p> <p>10001<sub>B</sub> Main stack pointer, MSP.</p> <p>10010<sub>B</sub> Process stack pointer, PSP.</p> <p>10100<sub>B</sub> Bits[31:24] Control; Bits[23:8] Reserved; Bits[7:0] PRIMASK.</p> <p>In each field, the valid bits are packed with leading zeros. For example DCRDR [31L26] is 0b00000.</p>
<b>REGWnR</b>	16	rw	<p><b>REGWnR specifies the type of access for the transfer</b></p> <p>0<sub>B</sub> read.</p> <p>1<sub>B</sub> write.</p>
<b>0</b>	[31:17], [15:5]	r	<b>Reserved</b>

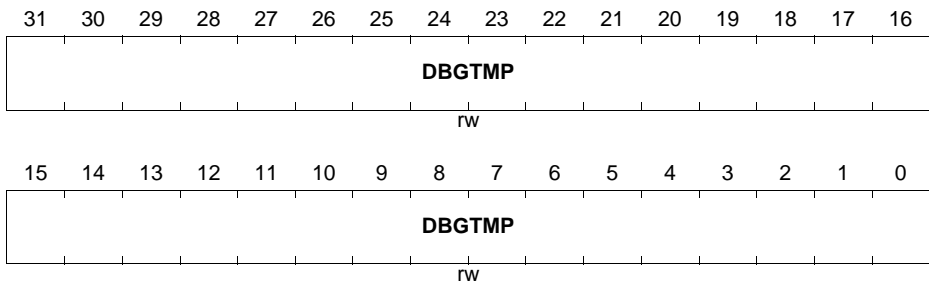
## 24.8.4 DCRDR - Debug Core Register Data Register

### SCS\_DCRDR

The DCRDR works with the DCRSR (Debug Core Register Selector Register). The DCRDR provides debug access to the ARM core registers and special-purpose registers. The DCRDR is the data register for these accesses.

### SCS\_DCRDR

**Debug Core Register Data Register (DF8<sub>H</sub>)** **Reset Value: xxxx xxxx<sub>H</sub>**



Field	Bits	Type	Description
<b>DBGTMP</b>	[31:0]	rw	<b>DBGTMP - Data temporary cache, for reading and writing register.</b> This register is UNKONWN: <ul style="list-style-type: none"> <li>• on reset</li> <li>• when DHCSR.S_HALT = 0</li> <li>• when DHCSR.S_REGRDY = 0 during execution of a DCRSR based transaction that updates the register.</li> </ul>

## 24.8.5 DEMCR - Debug Exception and Monitor Control Register

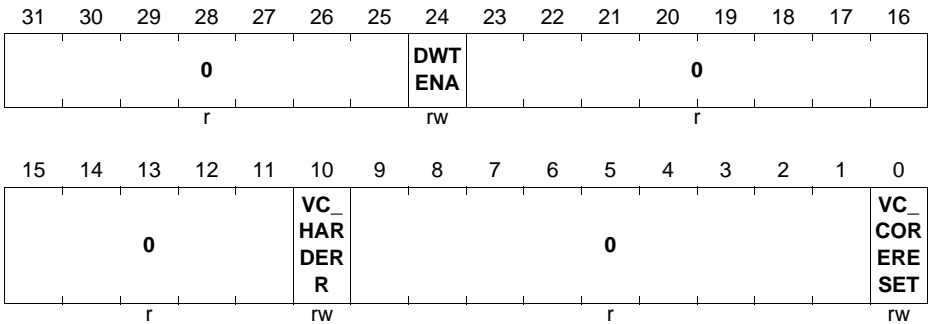
### SCS\_DEMCR

The DEMCR purpose is to manage vector catch behavior and enable the DWT.

A Power-on reset sets all register bits to 0. A local reset sets DWTENA to 0 but does not affect VC-HARDERR or VC\_CORERESSET.

**SCS\_DEMCR**

**Debug Exception and Monitor Control Register (DFC<sub>H</sub>)** Reset Value: 0000 0000<sub>H</sub>



Field	Bits	Type	Description
<b>VC_CORERES ET</b>	0	rw	<b>VC_CORERESSET - Enable Reset Vector Catch. This causes a Local reset to handle a running system</b> 0 <sub>B</sub> Reset Vector Catch disabled. 1 <sub>B</sub> Reset Vector Catch enabled. <i>Note: If DHCSR.C_DEBUGEN is set to 0, the processor ignores the value of this bit.</i>
<b>VC_HARDERR</b>	10	rw	<b>VC_CORERESSET - Enable Reset Vector Catch. This causes a Local reset to halt a running system.</b> 0 <sub>B</sub> halting debug trap disabled. 1 <sub>B</sub> halting debug trap enabled. <i>Note: If DHCSR.C_DEBUGEN is set to 0, the processor ignores the value of this bit.</i>
<b>DWTENA</b>	24	rw	<b>DWTENA - Global enable for all features configured by the DWT unit.</b> 0 <sub>B</sub> DWT disabled. 1 <sub>B</sub> DWT enabled. <i>Note: When DWTENA is set to 0 DWT registers return UNKNOWN values on reads. In addition the processor ignores writes to the DWT while DWTENA is 0.</i>

Field	Bits	Type	Description
<b>0</b>	[31:25] , [23:16] , [15:11] , [9:1]	r	<b>Reserved</b>

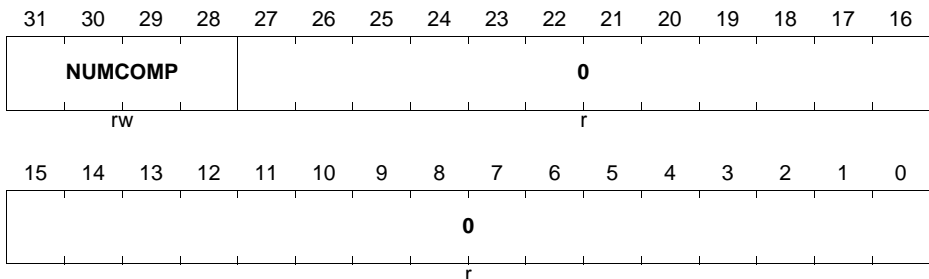
### 24.8.6 DWT\_CTRL - Data Watchpoint Control Register

#### DWT\_CTRL

The DWT\_CTRL register defines the number of comparators implemented.

#### DWT\_CTRL

**Debug Halting Control and Status Register (000<sub>H</sub>)**      **Reset Value: 0000 0000<sub>H</sub>**



Field	Bits	Type	Description
<b>NUMCOMP</b>	[31:28]	rw	<b>Number of comparators available</b> 0000 <sub>B</sub> No comparator support.
<b>0</b>	[27:0]	r	<b>Reserved</b>

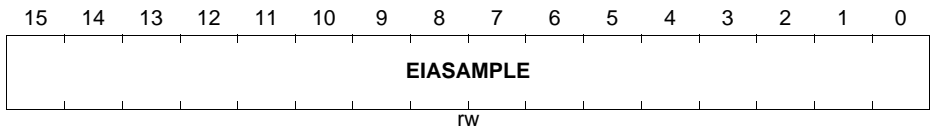
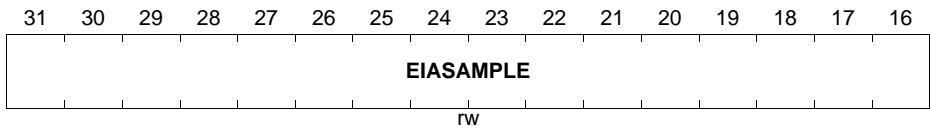
### 24.8.7 DWT\_PCSR - Program Counter Sample Register

#### DWT\_PCSR

The DWT\_PCSR register samples the current value of the program counter. The register is UNKNOWN on reset.

**DWT\_PCSR**

**Program Counter Sample Register (01C<sub>H</sub>)** **Reset Value: xxxx xxxx<sub>H</sub>**



Field	Bits	Type	Description
<b>EIASAMPLE</b>	[31:0]	rw	<b>EIASAMPLE</b> Executed instruction address sample register

**24.8.8 DWT\_COMPx - DWT Comparator register**

**DWT\_COMPx**

The DWT\_COMPx register provides a reference value for use by comparator x. The value is UNKNOWN on reset. DWT\_CTRL.NUMCOMP defines the number of implemented DWT\_COMPx register, from 0 to (NUMCOMP-1).

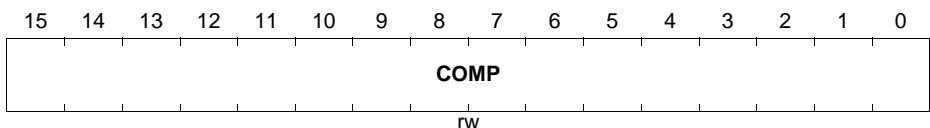
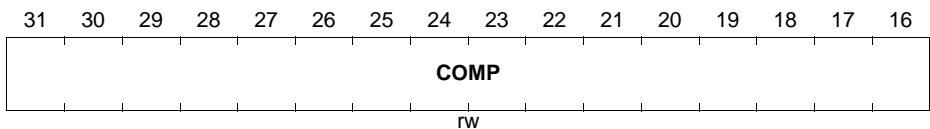
The DWT\_COMP [1 .. 0] register are implemented.

**DWT\_COMP0**

**DWT Comparator register 0 (020<sub>H</sub>)** **Reset Value: xxxx xxxx<sub>H</sub>**

**DWT\_COMP1**

**DWT Comparator register 1 (030<sub>H</sub>)** **Reset Value: xxxx xxxx<sub>H</sub>**



Field	Bits	Type	Description
<b>COMP</b>	[31:0]	rw	<b>COMP</b> Reference value for comparison

### 24.8.9 DWT\_MASKx - DWT Comparator Mask Register

#### DWT\_MASKx

The DWT\_MASKx register provides the size of the ignore mask applied to the access address range matching by comparator x. The value is UNKONWN on reset. DWT\_CTRL.NUMCOMP defines the number of implemented DWT\_COMPx register, from 0 to (NUMCOMP-1).

The DWT\_MASK [1 .. 0] register are implemented.

#### DWT\_MASK0

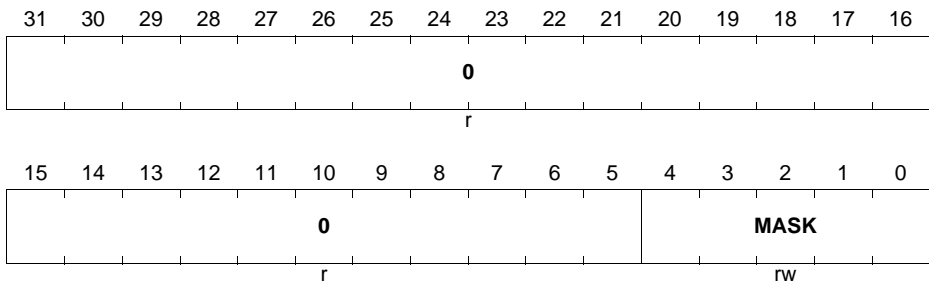
**Debug Halting Control and Status Register (24<sub>H</sub>)**

**Reset Value: 0000 0000<sub>H</sub>**

#### DWT\_MASK1

**Debug Halting Control and Status Register (34<sub>H</sub>)**

**Reset Value: 0000 0000<sub>H</sub>**



Field	Bits	Type	Description
<b>MASK</b>	[4:0]	rw	<b>MASK</b> The size of the ignore mask applied to address range matching. Writing all ones to this field and reading it back can be used to determine the maximum mask size supported (not all mask bit must be implemented).
<b>0</b>	[31:5]	r	<b>Reserved</b>



Field	Bits	Type	Description
<b>MATCHED</b>	24	rw	<b>MATCHED</b> Comparator match. It indicates that the operation defined by FUNCTION has occurred since the bit was last read. $0_B$ the associated comparator has matched. $1_B$ the associated comparator has not matched. <i>Note: Reading the register clears this bit to 0.</i>
<b>0</b>	[31:25] , [23:16] , [15:4]	r	<b>Reserved</b>

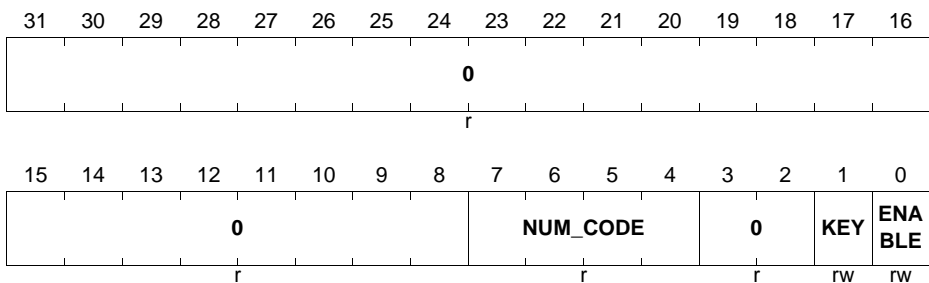
### 24.8.11 BP\_CTRL - Breakpoint Control Register

#### BP\_CTRL

The Breakpoint Control Register provides BPU implementation information and the global enable for the BPU.

#### BP\_CTRL

**Breakpoint Control Register (000<sub>H</sub>)**      **Reset Value: 0000 0040<sub>H</sub>**



Field	Bits	Type	Description
<b>ENABLE</b>	0	rw	<b>ENABLE the BPU</b> $0_B$ BPU is disabled. $1_B$ BPU is enabled. <i>Note: This bit is set to 0 on Power-on reset.</i>



Field	Bits	Type	Description
<b>KEY</b>	1	rw	<b>KEY RAZ on reads, SBO for writes.</b> If written as zero, the write to the register is ignored.
<b>NUM_CODE</b>	[7:4]	r	<b>NUM_CODE, the number of breakpoint comparators.</b>
<b>0</b>	[31:8], [3:2]	r	<b>Reserved</b>

## 24.8.12 Breakpoint Comparator Registers

### BP\_COMPx

The BP\_COMPx register holds a breakpoint address for comparison with instruction addresses in the Code memory region. A comparator can only be enabled when BP\_CTRL.ENABLE is set to 1. BP\_CTRL.NUM\_CODE defines the number of implemented BP\_COMPx registers, from 0 to (NUM\_CODE-1).

The BP\_COMP [3 .. 0] register are implemented.

#### BP\_COMP0

**Brakpoint Comparator X Register (008<sub>H</sub>)                      Reset Value: 0000 0000<sub>H</sub>**

#### BP\_COMP1

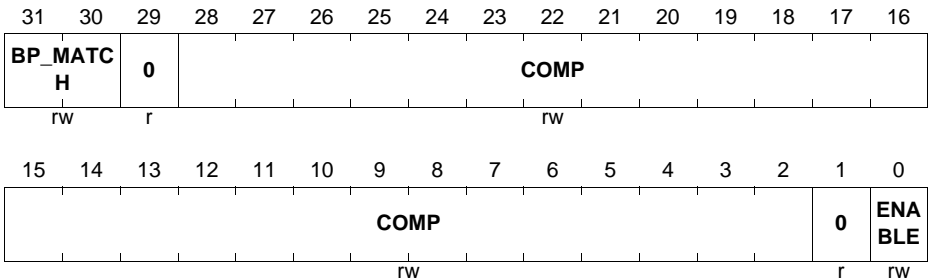
**Brakpoint Comparator X Register (00C<sub>H</sub>)                      Reset Value: 0000 0000<sub>H</sub>**

#### BP\_COMP2

**Brakpoint Comparator X Register (010<sub>H</sub>)                      Reset Value: 0000 0000<sub>H</sub>**

#### BP\_COMP3

**Brakpoint Comparator X Register (014<sub>H</sub>)                      Reset Value: 0000 0000<sub>H</sub>**



Field	Bits	Type	Description
<b>ENABLE</b>	0	rw	<p><b>ENABLE the comparator</b></p> <p>0<sub>B</sub> Comparator is disabled. 1<sub>B</sub> Comparator is enabled.</p> <p><i>Note: This bit is set to 0 on a Power-on reset. BP_CTRL:ENABLE must also be set to 1 to enable a comparator.</i></p>
<b>COMP</b>	[28:2]	rw	<p><b>Stores bits [28:0] of the comparison address.</b></p> <p>The comparison address is compared with the address from the Code memory region. Bits [31:29] and [1:0] of the comparison address are zero.</p> <p>0<sub>B</sub> Comparator is disabled. 1<sub>B</sub> Comparator is enabled.</p> <p><i>Note: The field is UNKNOWN on Power-on reset.</i></p>
<b>BP_MATCH</b>	[31:30]	rw	<p><b>BP_MATCH defines the behavior when the COMP address is matched.</b></p> <p>00<sub>B</sub> no breakpoint matching. 01<sub>B</sub> breakpoint on lower halfword, upper is unaffected. 10<sub>B</sub> breakpoint on upper halfword, lower is unaffected. 11<sub>B</sub> breakpoint on both lower and upper halfwords.</p> <p><i>Note: The field is UNKNOWN on reset.</i></p>
<b>0</b>	29, 1	r	<b>Reserved</b>

# **Lists of Figures and Tables**

## List of Figures

Figure 1-1	XMC1200 Functional diagram . . . . .	1-3
Figure 2-1	Cortex-M0 Block Diagram . . . . .	2-3
Figure 2-2	Core registers . . . . .	2-5
Figure 2-3	Memory map . . . . .	2-18
Figure 2-4	Memory system ordering . . . . .	2-20
Figure 2-5	Little-endian format (Example) . . . . .	2-22
Figure 2-6	Vector table . . . . .	2-29
Figure 2-7	Exception stack frame . . . . .	2-33
Figure 4-1	Block Diagram on Service Request Processing . . . . .	4-2
Figure 4-2	Example for Service Request Distribution . . . . .	4-3
Figure 5-1	Interrupt Priority Register . . . . .	5-5
Figure 5-2	Typical Interrupt Response Time . . . . .	5-6
Figure 5-3	Typical Module Interrupt Structure . . . . .	5-7
Figure 6-1	Event Request Unit Overview . . . . .	6-1
Figure 6-2	Event Request Select Unit Overview . . . . .	6-2
Figure 6-3	Event Trigger Logic Overview . . . . .	6-3
Figure 6-4	ERU Cross Connect Matrix . . . . .	6-5
Figure 6-5	Output Gating Unit for Output Channel y . . . . .	6-6
Figure 6-6	ERU Interconnects Overview . . . . .	6-17
Figure 7-1	XMC1200 Address Space . . . . .	7-2
Figure 8-1	Logical structure of the NVM module . . . . .	8-1
Figure 8-2	Decomposition of Logical Address . . . . .	8-3
Figure 8-3	Structure of a Page . . . . .	8-4
Figure 8-4	State Diagram of the NVM Module Timings are preliminary . . . . .	8-22
Figure 10-1	Watchdog Timer Block Diagram . . . . .	10-2
Figure 10-2	Reset without pre-warning . . . . .	10-3
Figure 10-3	Reset after pre-warning . . . . .	10-4
Figure 10-4	Reset upon servicing in a wrong window . . . . .	10-5
Figure 10-5	Reset upon servicing with a wrong magic word . . . . .	10-5
Figure 11-1	Real Time Clock Block Diagram Structure . . . . .	11-2
Figure 11-2	Block Diagram of RTC Time Counter . . . . .	11-3
Figure 11-3	RTC Clock selection . . . . .	11-5
Figure 12-1	SCU Block Diagram . . . . .	12-2
Figure 12-2	Service Request Handling . . . . .	12-4
Figure 12-3	System States Diagram . . . . .	12-8
Figure 12-4	Clock System Block Diagram . . . . .	12-16
Figure 14-1	LEDTS Block Diagram . . . . .	14-3
Figure 14-2	Time-Multiplexed LEDTS Functions on Pin (Example) . . . . .	14-6
Figure 14-3	Activate Internal Compare/Line Register for New Time Slice . . . . .	14-7
Figure 14-4	LED Function Control Circuit (also provides pad oscillator enable) . . . . .	14-9
Figure 14-5	Touch-Sense Oscillator Control Circuit . . . . .	14-10

**List of Figures**

Figure 14-6	Hardware-Controlled Pad Turns for Autoscan of Four TSIN[x] with Extended Frames 14-11	
Figure 14-7	Scheme A Touch-Sense Oscillator Control Circuit . . . . .	14-12
Figure 14-8	Scheme A Pin Oscillation Profile . . . . .	14-13
Figure 14-9	Scheme B Touch-Sense Oscillator Control Circuit . . . . .	14-14
Figure 14-10	Scheme B Pin Oscillation Profile . . . . .	14-15
Figure 14-11	Over-rule Control on Pin for Touch-Sense Function ( <b>Scheme A</b> ) .	14-25
Figure 14-12	Over-rule Control on Pin for Touch-Sense Function ( <b>Scheme B</b> ) .	14-26
Figure 14-13	Synchronized Kernel Start Options (Example with 2 Kernels) . . .	14-28
Figure 14-14	Illustration of Synchronization on Enabled Autoscan Time Period	14-29
Figure 15-1	USIC Module/Channel Structure . . . . .	15-4
Figure 15-2	Baud Rate Generator . . . . .	15-9
Figure 15-3	Principle of Data Buffering . . . . .	15-10
Figure 15-4	Data Access Structure without additional Data Buffer . . . . .	15-11
Figure 15-5	Data Access Structure with FIFO . . . . .	15-13
Figure 15-6	General Event and Interrupt Structure . . . . .	15-16
Figure 15-7	Transmit Events and Interrupts . . . . .	15-18
Figure 15-8	Receive Events and Interrupts . . . . .	15-19
Figure 15-9	Baud Rate Generator Event and Interrupt . . . . .	15-20
Figure 15-10	Input Conditioning for DX0 and DX[5:3] . . . . .	15-22
Figure 15-11	Input Conditioning for DX[2:1] . . . . .	15-23
Figure 15-12	Delay Compensation Enable in DX1 . . . . .	15-24
Figure 15-13	Divider Mode Counter . . . . .	15-27
Figure 15-14	Protocol-Related Counter (Capture Mode) . . . . .	15-28
Figure 15-15	Time Quanta Counter . . . . .	15-28
Figure 15-16	Master Clock Output Configuration . . . . .	15-29
Figure 15-17	Transmit Data Path . . . . .	15-31
Figure 15-18	Transmit Data Validation . . . . .	15-34
Figure 15-19	Receive Data Path . . . . .	15-36
Figure 15-20	FIFO Buffer Overview . . . . .	15-38
Figure 15-21	FIFO Buffer Partitioning . . . . .	15-40
Figure 15-22	Standard Transmit Buffer Event Examples . . . . .	15-42
Figure 15-23	Transmit Buffer Events . . . . .	15-43
Figure 15-24	Standard Receive Buffer Event Examples . . . . .	15-46
Figure 15-25	Receiver Buffer Events in Filling Level Mode . . . . .	15-47
Figure 15-26	Receiver Buffer Events in RCI Mode . . . . .	15-48
Figure 15-27	Bypass Data Validation . . . . .	15-50
Figure 15-28	TCI Handling with FIFO / Bypass . . . . .	15-52
Figure 15-29	ASC Signal Connections for Full-Duplex Communication . . . . .	15-53
Figure 15-30	ASC Signal Connections for Half-Duplex Communication . . . . .	15-54
Figure 15-31	Standard ASC Frame Format . . . . .	15-55
Figure 15-32	ASC Bit Timing . . . . .	15-58
Figure 15-33	Transmitter Pulse Length Control . . . . .	15-60

**List of Figures**

Figure 15-34	Pulse Output Example . . . . .	15-61
Figure 15-35	SSC Signals for Standard Full-Duplex Communication . . . . .	15-73
Figure 15-36	4-Wire SSC Standard Communication Signals . . . . .	15-75
Figure 15-37	SSC Data Signals . . . . .	15-75
Figure 15-38	SSC Shift Clock Signals . . . . .	15-76
Figure 15-39	SCLKOUT Configuration in SSC Master Mode . . . . .	15-78
Figure 15-40	SLPHSEL Configuration in SSC Slave Mode . . . . .	15-79
Figure 15-41	SSC Slave Select Signals . . . . .	15-80
Figure 15-42	Data Frames without/with Parity . . . . .	15-83
Figure 15-43	Quad-SSC Example . . . . .	15-86
Figure 15-44	Connections for Quad-SSC Example . . . . .	15-87
Figure 15-45	MSLS Generation in SSC Master Mode . . . . .	15-89
Figure 15-46	SSC Closed-loop Delay . . . . .	15-103
Figure 15-47	SSC Closed-loop Delay Timing Waveform . . . . .	15-105
Figure 15-48	SSC Master Mode with Delay Compensation . . . . .	15-106
Figure 15-49	SSC Complete Closed-loop Delay Compensation . . . . .	15-107
Figure 15-50	IIC Signal Connections . . . . .	15-109
Figure 15-51	IIC Frame Example (simplified) . . . . .	15-110
Figure 15-52	Start Symbol Timing . . . . .	15-118
Figure 15-53	Repeated Start Symbol Timing . . . . .	15-118
Figure 15-54	Stop Symbol Timing . . . . .	15-119
Figure 15-55	Data Bit Symbol . . . . .	15-119
Figure 15-56	IIC Master Transmission . . . . .	15-124
Figure 15-57	Interrupt Events on Data Transfers . . . . .	15-127
Figure 15-58	IIS Signals . . . . .	15-135
Figure 15-59	Protocol Overview . . . . .	15-136
Figure 15-60	Transfer Delay for IIS . . . . .	15-136
Figure 15-61	Connection of External Audio Devices . . . . .	15-137
Figure 15-62	Transfer Delay with Delay 1 . . . . .	15-139
Figure 15-63	No Transfer Delay . . . . .	15-140
Figure 15-64	MCLK and SCLK for IIS . . . . .	15-145
Figure 15-65	USIC Module and Channel Registers . . . . .	15-154
Figure 15-66	USIC Module Structure in XMC1200 . . . . .	15-226
Figure 15-67	USIC Channel I/O Lines . . . . .	15-227
Figure 16-1	ADC Structure Overview . . . . .	16-3
Figure 16-2	ADC Kernel Block Diagram . . . . .	16-4
Figure 16-3	ADC Cluster Structure . . . . .	16-5
Figure 16-4	Conversion Request Unit . . . . .	16-6
Figure 16-5	Signal Path Model . . . . .	16-9
Figure 16-6	Clock Signal Summary . . . . .	16-12
Figure 16-7	Queued Request Source . . . . .	16-19
Figure 16-8	Interrupt Generation of a Queued Request Source . . . . .	16-22
Figure 16-9	Scan Request Source . . . . .	16-23

**List of Figures**

Figure 16-10	Arbitration Round with 4 Arbitration Slots	16-26
Figure 16-11	Conversion Start Modes	16-29
Figure 16-12	Alias Feature	16-32
Figure 16-13	Result Monitoring through Limit Checking	16-33
Figure 16-14	Result Monitoring through Compare with Hysteresis	16-35
Figure 16-15	Boundary Flag Switching	16-36
Figure 16-16	Boundary Flag Control	16-37
Figure 16-17	Conversion Result Storage	16-43
Figure 16-18	Result Storage Options	16-44
Figure 16-19	Result FIFO Buffers	16-46
Figure 16-20	Standard Data Reduction Filter	16-49
Figure 16-21	Standard Data Reduction Filter with FIFO Enabled	16-50
Figure 16-22	FIR Filter Structure	16-51
Figure 16-23	IIR Filter Structure	16-52
Figure 16-24	Result Difference	16-53
Figure 16-25	Parallel Conversions	16-55
Figure 16-26	Synchronization via ANON and Ready Signals	16-56
Figure 16-27	Timer Mode for Equidistant Sampling	16-57
Figure 16-28	Broken Wire Detection	16-58
Figure 16-29	External Analog Multiplexer Example	16-60
Figure 17-1	Block diagram of Analog Comparator	17-2
Figure 17-2	Analog Comparator Reference Divider Function	17-3
Figure 17-3	Out of range comparator	17-4
Figure 19-1	CCU4 block diagram	19-5
Figure 19-2	CCU4 slice block diagram	19-6
Figure 19-3	Slice input selector diagram	19-9
Figure 19-4	Slice connection matrix diagram	19-11
Figure 19-5	Timer start/stop control diagram	19-12
Figure 19-6	Starting multiple timers synchronously	19-13
Figure 19-7	CC4y Status Bit	19-14
Figure 19-8	Shadow registers overview	19-16
Figure 19-9	Shadow transfer enable logic	19-17
Figure 19-10	Shadow transfer timing example - center aligned mode	19-18
Figure 19-11	Usage of the CCU4x.MCSS input	19-19
Figure 19-12	Edge aligned mode, <b>CC4yTC.TCM</b> = 0 <sub>B</sub>	19-20
Figure 19-13	Center aligned mode, <b>CC4yTC.TCM</b> = 1 <sub>B</sub>	19-21
Figure 19-14	Single shot edge aligned - <b>CC4yTC.TSSM</b> = 1 <sub>B</sub> , <b>CC4yTC.TCM</b> = 0 <sub>B</sub>	19-21
Figure 19-15	Single shot center aligned - <b>CC4yTC.TSSM</b> = 1 <sub>B</sub> , <b>CC4yTC.TCM</b> = 1 <sub>B</sub>	19-22
Figure 19-16	Start (as start)/ stop (as stop) - <b>CC4yTC.STRM</b> = 0 <sub>B</sub> , <b>CC4yTC.ENDM</b> = 00 <sub>B</sub>	19-24
Figure 19-17	Start (as start)/ stop (as flush) - <b>CC4yTC.STRM</b> = 0 <sub>B</sub> , <b>CC4yTC.ENDM</b> =	

**List of Figures**

	01 <sub>B</sub> 19-24	
Figure 19-18	Start (as flush and start)/ stop (as stop) - <b>CC4yTC</b> .STRM = 1 <sub>B</sub> , <b>CC4yTC</b> .ENDM = 00 <sub>B</sub> 19-25	
Figure 19-19	Start (as start)/ stop (as flush and stop) - <b>CC4yTC</b> .STRM = 0 <sub>B</sub> , <b>CC4yTC</b> .ENDM = 10 <sub>B</sub> 19-25	
Figure 19-20	External counting direction. . . . .	19-26
Figure 19-21	External gating . . . . .	19-27
Figure 19-22	External count . . . . .	19-28
Figure 19-23	External load . . . . .	19-29
Figure 19-24	External capture - <b>CC4yCMC</b> .CAP0S != 00 <sub>B</sub> , <b>CC4yCMC</b> .CAP1S = 00 <sub>B</sub> . . 19-31	
Figure 19-25	External capture - <b>CC4yCMC</b> .CAP0S != 00 <sub>B</sub> , <b>CC4yCMC</b> .CAP1S != 00 <sub>B</sub> . 19-32	
Figure 19-26	Slice capture logic . . . . .	19-33
Figure 19-27	External Capture - <b>CC4yTC</b> .SCE = 1 <sub>B</sub> . . . . .	19-34
Figure 19-28	Slice Capture Logic - <b>CC4yTC</b> .SCE = 1 <sub>B</sub> . . . . .	19-34
Figure 19-29	Capture Extended Read Back - Depth 4 . . . . .	19-36
Figure 19-30	Depth 4 software access example . . . . .	19-37
Figure 19-31	Capture Extended Read Back - Depth 2 . . . . .	19-38
Figure 19-32	Depth 2 software access example . . . . .	19-38
Figure 19-33	External modulation clearing the ST bit - <b>CC4yTC</b> .EMT = 0 <sub>B</sub> . . . . .	19-39
Figure 19-34	External modulation clearing the ST bit - <b>CC4yTC</b> .EMT = 0 <sub>B</sub> , <b>CC4yTC</b> .EMS = 1 <sub>B</sub> 19-40	
Figure 19-35	External modulation gating the output - <b>CC4yTC</b> .EMT = 1 <sub>B</sub> . . . . .	19-40
Figure 19-36	Trap control diagram . . . . .	19-41
Figure 19-37	Trap timing diagram, <b>CC4yPSL</b> .PSL = 0 <sub>B</sub> (output passive level is 0 <sub>B</sub> ) . . . 19-42	
Figure 19-38	Trap synchronization with the PWM signal, <b>CC4yTC</b> .TRPSE = 1 <sub>B</sub> 19-43	
Figure 19-39	Status bit override . . . . .	19-44
Figure 19-40	Multi channel pattern synchronization . . . . .	19-45
Figure 19-41	Multi Channel mode for multiple Timer Slices . . . . .	19-45
Figure 19-42	CC4y Status bit and Output Path. . . . .	19-46
Figure 19-43	Multi Channel Mode Control Logic. . . . .	19-47
Figure 19-44	Timer Concatenation Example. . . . .	19-48
Figure 19-45	Timer Concatenation Link . . . . .	19-49
Figure 19-46	Capture/Load Timer Concatenation. . . . .	19-50
Figure 19-47	32 bit concatenation timing diagram . . . . .	19-51
Figure 19-48	Timer concatenation control logic . . . . .	19-52
Figure 19-49	Dither structure overview . . . . .	19-53
Figure 19-50	Dither control logic . . . . .	19-55
Figure 19-51	Dither timing diagram in edge aligned - <b>CC4yTC</b> .DITHE = 01 <sub>B</sub> . . . 19-55	
Figure 19-52	Dither timing diagram in edge aligned - <b>CC4yTC</b> .DITHE = 10 <sub>B</sub> . . . 19-56	
Figure 19-53	Dither timing diagram in edge aligned - <b>CC4yTC</b> .DITHE = 11 <sub>B</sub> . . . 19-56	



**List of Figures**

Figure 19-54	Dither timing diagram in center aligned - <b>CC4yTC.DITHE</b> = 01 <sub>B</sub> . . .	19-56
Figure 19-55	Dither timing diagram in center aligned - <b>CC4yTC.DITHE</b> = 10 <sub>B</sub> . . .	19-57
Figure 19-56	Dither timing diagram in center aligned - <b>CC4yTC.DITHE</b> = 11 <sub>B</sub> . . .	19-57
Figure 19-57	Floating prescaler in compare mode overview . . . . .	19-59
Figure 19-58	Floating Prescaler in capture mode overview . . . . .	19-60
Figure 19-59	PWM with 100% duty cycle - Edge Aligned Mode . . . . .	19-61
Figure 19-60	PWM with 100% duty cycle - Center Aligned Mode . . . . .	19-61
Figure 19-61	PWM with 0% duty cycle - Edge Aligned Mode . . . . .	19-62
Figure 19-62	PWM with 0% duty cycle - Center Aligned Mode . . . . .	19-62
Figure 19-63	Floating Prescaler capture mode usage . . . . .	19-63
Figure 19-64	Floating Prescaler compare mode usage - Edge Aligned . . . . .	19-64
Figure 19-65	Floating Prescaler compare mode usage - Center Aligned . . . . .	19-64
Figure 19-66	Capture mode usage - single channel . . . . .	19-68
Figure 19-67	Three Capture profiles - <b>CC4yTC.SCE</b> = 1 <sub>B</sub> . . . . .	19-69
Figure 19-68	High dynamics capturing with software controlled timestamp . . . . .	19-70
Figure 19-69	Extended read back during high load . . . . .	19-71
Figure 19-70	Capture grouping with extended read back . . . . .	19-71
Figure 19-71	Memory structure for extended read back . . . . .	19-73
Figure 19-72	Slice interrupt structure overview . . . . .	19-75
Figure 19-73	Slice Interrupt Node Pointer overview . . . . .	19-76
Figure 19-74	CCU4 service request overview . . . . .	19-77
Figure 19-75	CCU4 registers overview . . . . .	19-80
Figure 20-1	BCCU Kernel Block Diagram . . . . .	20-2
Figure 20-2	Channel Block Diagram . . . . .	20-3
Figure 20-3	Dimming Engine Block Diagram . . . . .	20-4
Figure 20-4	Coarse Piecewise pseudo-exponential curve . . . . .	20-6
Figure 20-5	Coarse Piecewise pseudo-exponential curve with the dimming level on a logarithmic scale as the human eye sees it (real and ideal) 20-7	
Figure 20-6	Dimming from 0 to 18 along the coarse curve without and with dither enabled 20-8	
Figure 20-7	Dimming from 18 to 0 along the coarse curve without and with dither enabled 20-8	
Figure 20-8	Lower section of the coarse curve (real and ideal) . . . . .	20-9
Figure 20-9	Lower section of the fine curve (real and ideal) . . . . .	20-11
Figure 20-10	Dithering examples . . . . .	20-12
Figure 20-11	Lower section of the coarse curve with dithering enabled (real and ideal) 20-12	
Figure 20-12	Linear Walker Block Diagram . . . . .	20-13
Figure 20-13	Packer Block Diagram . . . . .	20-14
Figure 20-14	Signal Packing (example) . . . . .	20-15
Figure 20-15	BCCU Trigger Generation . . . . .	20-17
Figure 20-16	Trap Control . . . . .	20-18
Figure 20-17	BCCU clocks . . . . .	20-19

**List of Figures**

Figure 20-18	Service Request Nodes . . . . .	20-20
Figure 20-19	Simple DAC on one pin . . . . .	20-22
Figure 21-1	General Structure of a digital Port Pin . . . . .	21-2
Figure 21-2	Port Pin in Power Save State. . . . .	21-7
Figure 21-3	Analog Port Structure. . . . .	21-8
Figure 22-1	Startup sequence. . . . .	22-1
Figure 23-1	Baud Rate configuration sequence during XMC1200 ASC BSL entry. . . . .	23-5
Figure 23-2	XMC1200 Standard ASC BSL: Application download protocol . . . . .	23-6
Figure 23-3	Handshake protocol for XMC1200 ASC BSL entry . . . . .	23-8
Figure 24-1	Debug and Trace System block diagram. . . . .	24-2
Figure 24-2	SPD Encoding Example. . . . .	24-7
Figure 24-3	HAR - Halt After Reset Flow . . . . .	24-10
Figure 24-4	HOT PLUG or Warm Reset Flow. . . . .	24-12

## List of Tables

Table 1	Bit Function Terminology .....	P-3
Table 2	Register Access Modes .....	P-3
Table 2-1	Summary of processor mode, execution, and stack use options ...	2-4
Table 2-2	Core register set summary .....	2-5
Table 2-3	PSR register combinations .....	2-9
Table 2-4	CMSIS functions to generate some Cortex-M0 instructions .....	2-16
Table 2-5	CMSIS functions to access the special registers .....	2-17
Table 2-6	Memory access behavior .....	2-20
Table 2-7	Cortex-M0 instructions .....	2-23
Table 2-8	Exception types .....	2-27
Table 2-9	Properties of the different exception types .....	2-27
Table 2-10	Remapped Vector Table .....	2-30
Table 2-11	Exception return behavior .....	2-34
Table 2-12	Core peripheral register regions .....	2-38
Table 2-13	Register Overview .....	2-40
Table 2-14	System fault handler priority fields .....	2-49
Table 4-1	Abbreviations .....	4-1
Table 4-2	Interrupt services per module .....	4-4
Table 5-1	Interrupt Node assignment .....	5-1
Table 5-2	CMSIS functions for NVIC control .....	5-3
Table 5-3	CMSIS access NVIC functions .....	5-4
Table 5-4	Registers Address Space .....	5-8
Table 5-5	Register Overview .....	5-8
Table 5-6	Interrupt Source Overview .....	5-14
Table 6-1	Registers Address Space .....	6-10
Table 6-2	Register Overview .....	6-10
Table 6-3	ERU0 Pin Connections .....	6-17
Table 7-1	Memory Map .....	7-3
Table 7-2	Memory Protection Measures .....	7-9
Table 7-3	List of Protected Register Bit Fields .....	7-10
Table 8-1	Module Specific Definitions .....	8-3
Table 8-2	Registers Address Space .....	8-9
Table 8-3	Registers Overview .....	8-9
Table 8-4	Incremental Update of a Block with Specially Constructed Data ..	8-20
Table 9-1	Peripherals Availability and Privilege Access Control .....	9-1
Table 9-2	Registers Address Space .....	9-3
Table 9-3	Register Overview .....	9-3
Table 10-1	Application Features .....	10-2
Table 10-2	Registers Address Space .....	10-9
Table 10-3	Register Overview .....	10-9
Table 10-4	Pin Table .....	10-16

**List of Tables**

Table 11-1	Application Features .....	11-1
Table 11-2	Registers Address Space .....	11-7
Table 11-3	Register Overview .....	11-7
Table 11-4	Pin Connections .....	11-19
Table 12-1	Service Requests .....	12-5
Table 12-2	PID Values of XMC1200 System ROM Table .....	12-6
Table 12-3	Reset Overview .....	12-14
Table 12-4	DCO calibration data in Flash CS0 .....	12-20
Table 12-5	Base Addresses of sub-sections of SCU registers .....	12-22
Table 12-6	Registers Address Space .....	12-22
Table 12-7	Registers Overview .....	12-23
Table 13-1	Registers Address Space .....	13-4
Table 13-2	Registers Overview .....	13-4
Table 14-1	Abbreviations in chapter .....	14-1
Table 14-2	LEDTS Applications .....	14-2
Table 14-3	LEDTS Interrupt Events .....	14-18
Table 14-4	LEDTS Events' Interrupt Node Control .....	14-18
Table 14-5	Interpretation of FNCOL Bit Field .....	14-21
Table 14-6	Combinations of pad and hysteresis configurations .....	14-23
Table 14-7	LEDTS Pin Control Signals .....	14-24
Table 14-8	Registers Address Space .....	14-30
Table 14-9	Register Overview of LEDTS .....	14-30
Table 14-10	Pin Connections .....	14-44
Table 15-1	Input Signals for Different Protocols .....	15-6
Table 15-2	Output Signals for Different Protocols .....	15-7
Table 15-3	USIC Communication Channel Behavior .....	15-15
Table 15-4	Data Transfer Events and Interrupt Handling .....	15-18
Table 15-5	Baud Rate Generator Event and Interrupt Handling .....	15-20
Table 15-6	Protocol-specific Events and Interrupt Handling .....	15-21
Table 15-7	Transmit Shift Register Composition .....	15-32
Table 15-8	Receive Shift Register Composition .....	15-37
Table 15-9	Transmit Buffer Events and Interrupt Handling .....	15-43
Table 15-10	Receive Buffer Events and Interrupt Handling .....	15-48
Table 15-11	SSC Communication Signals .....	15-74
Table 15-12	Master Transmit Data Formats .....	15-120
Table 15-13	Slave Transmit Data Format .....	15-121
Table 15-14	Valid TDF Codes Overview .....	15-122
Table 15-15	TDF Code Sequence for Master Transmit .....	15-125
Table 15-16	TDF Code Sequence for Master Receive (7-bit Addressing Mode) .....	15-125
Table 15-17	TDF Code Sequence for Master Receive (10-bit Addressing Mode) .....	15-126
Table 15-18	IIS IO Signals .....	15-134

**List of Tables**

Table 15-19	USIC Kernel-Related and Kernel Registers	15-154
Table 15-20	Registers Address Space	15-157
Table 15-21	FIFO and Reserved Address Space	15-157
Table 15-22	USIC Module 0 Channel 0 Interconnects	15-228
Table 15-23	USIC Module 0 Channel 1 Interconnects	15-231
Table 15-24	USIC Module 0 Module Interconnects	15-234
Table 16-1	Abbreviations used in ADC chapter	16-1
Table 16-2	VADC Applications	16-3
Table 16-3	Analog Part Power-Down Control Options	16-14
Table 16-4	Properties of Result FIFO Registers	16-47
Table 16-5	Function of Bitfield DRCTR	16-48
Table 16-6	EMUX Control Signal Coding	16-61
Table 16-7	Registers Address Space	16-64
Table 16-8	Registers Overview	16-64
Table 16-9	TS16_SSIG Trigger Set VADC	16-72
Table 16-10	Register Protection Groups	16-78
Table 16-11	Sample Time Coding	16-116
Table 16-12	General Converter Configuration in the XMC1200	16-151
Table 16-13	Synchronization Groups in the XMC1200	16-152
Table 16-14	Analog Connections in the XMC1200	16-153
Table 16-15	Digital Connections in the XMC1200	16-154
Table 17-1	Registers Address Space	17-5
Table 17-2	Registers Overview	17-5
Table 17-3	Analog Comparator Pin Connections	17-12
Table 17-4	Out of Range Comparator Pin Connections	17-12
Table 18-1	Registers Address Space	18-2
Table 18-2	Registers Overview	18-2
Table 19-1	Abbreviations table	19-1
Table 19-2	Applications summary	19-3
Table 19-3	CCU4 slice pin description	19-7
Table 19-4	Connection matrix available functions	19-10
Table 19-5	Dither bit reverse counter	19-54
Table 19-6	Dither modes	19-54
Table 19-7	Timer clock division options	19-58
Table 19-8	Bit reverse distribution	19-65
Table 19-9	Interrupt sources	19-74
Table 19-10	External clock operating conditions	19-78
Table 19-11	Registers Address Space	19-80
Table 19-12	Register Overview of CCU4	19-81
Table 19-13	CCU40 Pin Connections	19-137
Table 19-14	CCU40 - CC40 Pin Connections	19-138
Table 19-15	CCU40 - CC41 Pin Connections	19-139
Table 19-16	CCU40 - CC42 Pin Connections	19-140

**List of Tables**

Table 19-17	CCU40 - CC43 Pin Connections . . . . .	19-142
Table 20-1	Coarse Piece-Wise Pseudo-Exponential Curve . . . . .	20-4
Table 20-2	Quantized CoarsePiece-Wise Pseudo-Exponential Curve . . . . .	20-7
Table 20-3	Fine Piece-Wise Pseudo-Exponential Curve . . . . .	20-9
Table 20-4	Fine Piece-Wise Pseudo-Exponential Curve . . . . .	20-10
Table 20-5	Registers Address Space . . . . .	20-23
Table 20-6	Register Overview . . . . .	20-23
Table 20-7	Pin Connections . . . . .	20-48
Table 21-1	Port/Pin Overview . . . . .	21-1
Table 21-2	Registers Address Space . . . . .	21-11
Table 21-3	Register Overview . . . . .	21-11
Table 21-4	Registers Access Rights and Reset Classes . . . . .	21-13
Table 21-5	Standard PCx Coding . . . . .	21-17
Table 21-6	Pad Hysteresis Selection . . . . .	21-18
Table 21-7	Function of the Bits PRx and PSx . . . . .	21-33
Table 21-8	PCx Coding in Deep-Sleep mode . . . . .	21-38
Table 21-9	Package Pin Mapping Description . . . . .	21-42
Table 21-10	Package Pin Mapping . . . . .	21-42
Table 21-11	Port Pin for Boot Modes . . . . .	21-45
Table 21-12	Port I/O Function Description . . . . .	21-46
Table 21-13	Port I/O Functions . . . . .	21-47
Table 22-1	Flash data for SSW and user SW in XMC1200 . . . . .	22-10
Table 23-1	Supported Baud Rates . . . . .	23-4
Table 23-2	Scaling Factor Examples . . . . .	23-4
Table 23-3	Handshake protocol data definitions in XMC1200 ASC BSL . . . . .	23-7
Table 23-4	SSC BL: Determining the EEPROM Type and data-flow . . . . .	23-9
Table 23-5	User routines' in XMC1200 ROM . . . . .	23-11
Table 23-6	Status indicators returned by NVM routines in XMC1200 ROM . . . . .	23-12
Table 23-7	Basic Flash data for SSW and user SW in XMC1200 . . . . .	23-14
Table 24-1	Peripheral Suspend support . . . . .	24-13
Table 24-2	SWD toplevel IO signal . . . . .	24-15
Table 24-3	PID Values of XMC1200 ROM Table . . . . .	24-18
Table 24-4	Registers Address Space . . . . .	24-19
Table 24-5	Register Overview . . . . .	24-19

[www.infineon.com](http://www.infineon.com)

Published by Infineon Technologies AG