

Features

- Core
 - ARM® Cortex®-M4 with a 2 Kbytes cache running at up to 120 MHz
 - Memory Protection Unit (MPU)
 - DSP Instruction Set
 - Thumb®-2 instruction set
- Pin-to-pin compatible with SAM3N, SAM3S products (64- and 100- pin versions) and SAM7S legacy products (64-pin version)
- Memories
 - Up to 2048 Kbytes embedded Flash with optional dual bank and cache memory
 - Up to 160 Kbytes embedded SRAM
 - 16 Kbytes ROM with embedded boot loader routines (UART, USB) and IAP routines
 - 8-bit Static Memory Controller (SMC): SRAM, PSRAM, NOR and NAND Flash support
- System
 - Embedded voltage regulator for single supply operation
 - Power-on-Reset (POR), Brown-out Detector (BOD) and Watchdog for safe operation
 - Quartz or ceramic resonator oscillators: 3 to 20 MHz main power with Failure Detection and optional low-power 32.768 kHz for RTC or device clock
 - RTC with Gregorian and Persian Calendar mode, waveform generation in low-power modes
 - RTC clock calibration circuitry for 32.768 kHz crystal frequency compensation
 - High precision 8/12 MHz factory trimmed internal RC oscillator with 4 MHz default frequency for device startup. In-application trimming access for frequency adjustment
 - Slow Clock Internal RC oscillator as permanent low-power mode device clock
 - Two PLLs up to 240 MHz for device clock and for USB
 - Temperature Sensor
 - Up to 22 Peripheral DMA (PDC) Channels
- Low Power Modes
 - Sleep and Backup modes, down to 1 μ A in Backup mode
 - Ultra low-power RTC
- Peripherals
 - USB 2.0 Device: 12 Mbps, 2668 byte FIFO, up to 8 bidirectional Endpoints. On-Chip Transceiver
 - Up to 2 USARTs with ISO7816, IrDA®, RS-485, SPI, Manchester and Modem Mode
 - Two 2-wire UARTs
 - Up to 2 Two Wire Interface (I2C compatible), 1 SPI, 1 Serial Synchronous Controller (I2S), 1 High Speed Multimedia Card Interface (SDIO/SD Card/MMC)
 - 2 Three-Channel 16-bit Timer/Counter with capture, waveform, compare and PWM mode. Quadrature Decoder Logic and 2-bit Gray Up/Down Counter for Stepper Motor
 - 4-channel 16-bit PWM with Complementary Output, Fault Input, 12-bit Dead Time Generator Counter for Motor Control
 - 32-bit Real-time Timer and RTC with calendar and alarm features
 - Up to 16-channel, 1MSPS ADC with differential input mode and programmable gain stage and auto calibration
 - One 2-channel 12-bit 1MSPS DAC
 - One Analog Comparator with flexible input selection, Selectable input hysteresis
 - 32-bit Cyclic Redundancy Check Calculation Unit (CRCCU)
 - Write Protected Registers
- I/O
 - Up to 79 I/O lines with external interrupt capability (edge or level sensitivity), debouncing, glitch filtering and on-die Series Resistor Termination
 - Three 32-bit Parallel Input/Output Controllers, Peripheral DMA assisted Parallel Capture Mode
- Packages
 - 100-lead LQFP, 14 x 14 mm, pitch 0.5 mm/100-ball TFBGA, 9 x 9 mm, pitch 0.8 mm/100-ball VFBGA, 7 x 7 mm, pitch 0.65 mm
 - 64-lead LQFP, 10 x 10 mm, pitch 0.5 mm/64-lead QFN 9x9 mm, pitch 0.5 mm



AT91SAM ARM-based Flash MCU

SAM4S Series

Preliminary Datasheet

11100B-ATARM-31-Jul-12





1. Description

The Atmel SAM4S series is a member of a family of Flash microcontrollers based on the high performance 32-bit ARM Cortex-M4 RISC processor. It operates at a maximum speed of 120 MHz and features up to 2048 Kbytes of Flash, with optional dual bank implementation and cache memory, and up to 160 Kbytes of SRAM. The peripheral set includes a Full Speed USB Device port with embedded transceiver, a High Speed MCI for SDIO/SD/MMC, an External Bus Interface featuring a Static Memory Controller providing connection to SRAM, PSRAM, NOR Flash, LCD Module and NAND Flash, 2x USARTs, 2x UARTs, 2x TWIs, 3x SPI, an I2S, as well as 1 PWM timer, 2x three channel general-purpose 16-bit timers (with stepper motor and quadrature decoder logic support), an RTC, a 12-bit ADC, a 12-bit DAC and an analog comparator.

The SAM4S series is ready for capacitive touch thanks to the QTouch[®] library, offering an easy way to implement buttons, wheels and sliders.

The SAM4S device is a medium range general purpose microcontroller with the best ratio in terms of reduced power consumption, processing power and peripheral set. This enables the SAM4S to sustain a wide range of applications including consumer, industrial control, and PC peripherals.

It operates from 1.62V to 3.6V.

The SAM4S series is pin-to-pin compatible with the SAM3N, SAM3S series (64- and 100-pin versions) and SAM7S legacy series (64-pin versions).

1.1 Configuration Summary

The SAM4S series devices differ in memory size, package and features. [Table 1-1](#) summarizes the configurations of the device family.

Table 1-1. Configuration Summary

Feature	SAM4SD32C	SAM4SD32B	SAM4SD16C	SAM4SD16B	SAM4SA16C	SAM4SA16B	SAM4S16C	SAM4S16B	SAM4S8C	SAM4S8B
Flash	2 x 1024 Kbytes	2 x 1024 Kbytes	2 x 512 Kbytes	2 x 512 Kbytes	1024 Kbytes	1024 Kbytes	1024 Kbytes	1024 Kbytes	512 Kbytes	512 Kbytes
SRAM	160 Kbytes	160 Kbytes	160 Kbytes	160 Kbytes	160 Kbytes	160 Kbytes	128 Kbytes	128 Kbytes	128 Kbytes	128 Kbytes
HCACHE	2KBytes	2KBytes	2KBytes	2KBytes	2KBytes	2KBytes	-	-	-	-
Package	LQFP 100 TFBGA 100 VFBGA 100	LQFP 64 QFN 64	LQFP 100 TFBGA 100 VFBGA 100	LQFP 64 QFN 64	LQFP 100 TFBGA 100 VFBGA 100	LQFP 64 QFN 64	LQFP 100 TFBGA 100 VFBGA 100	LQFP 64 QFN 64	LQFP 100 TFBGA 100 VFBGA 100	LQFP 64 QFN 64
Number of PIOs	79	47	79	47	79	47	79	47	79	47
External Bus Interface	8-bit data, 4chip selects, 24-bit address	-	8-bit data, 4chip selects, 24-bit address	-	8-bit data, 4chip selects, 24-bit address	-	8-bit data, 4chip selects, 24-bit address	-	8-bit data, 4chip selects, 24-bit address	-
12-bit ADC	16 ch. ⁽¹⁾	11 ch. ⁽¹⁾	16 ch. ⁽¹⁾	11 ch. ⁽¹⁾	16 ch. ⁽¹⁾	11 ch. ⁽¹⁾	16 ch. ⁽¹⁾	11 ch. ⁽¹⁾	16 ch. ⁽¹⁾	11 ch. ⁽¹⁾
12-bit DAC	2 ch.	2 ch.	2 ch.	2 ch.	2 ch.	2 ch.	2 ch.	2 ch.	2 ch.	2 ch.
Timer Counter Channels	6	3	6	3	6	3	6	3	6	3
PDC Channels	22	22	22	22	22	22	22	22	22	22
USART/UART	2/2 ⁽²⁾	2/2 ⁽²⁾	2/2 ⁽²⁾	2/2 ⁽²⁾	2/2 ⁽²⁾	2/2 ⁽²⁾	2/2 ⁽²⁾	2/2 ⁽²⁾	2/2 ⁽²⁾	2/2 ⁽²⁾
HSMCI	1 port 4 bits	1 port 4 bits	1 port 4 bits	1 port 4 bits	1 port 4 bits	1 port 4 bits	1 port 4 bits	1 port 4 bits	1 port 4 bits	1 port 4 bits

Notes: 1. One channel is reserved for internal temperature sensor.

2. Full Modem support on USART1.

2. Block Diagram

Figure 2-1. SAM4S16, S8 Series 100-pin version Block Diagram

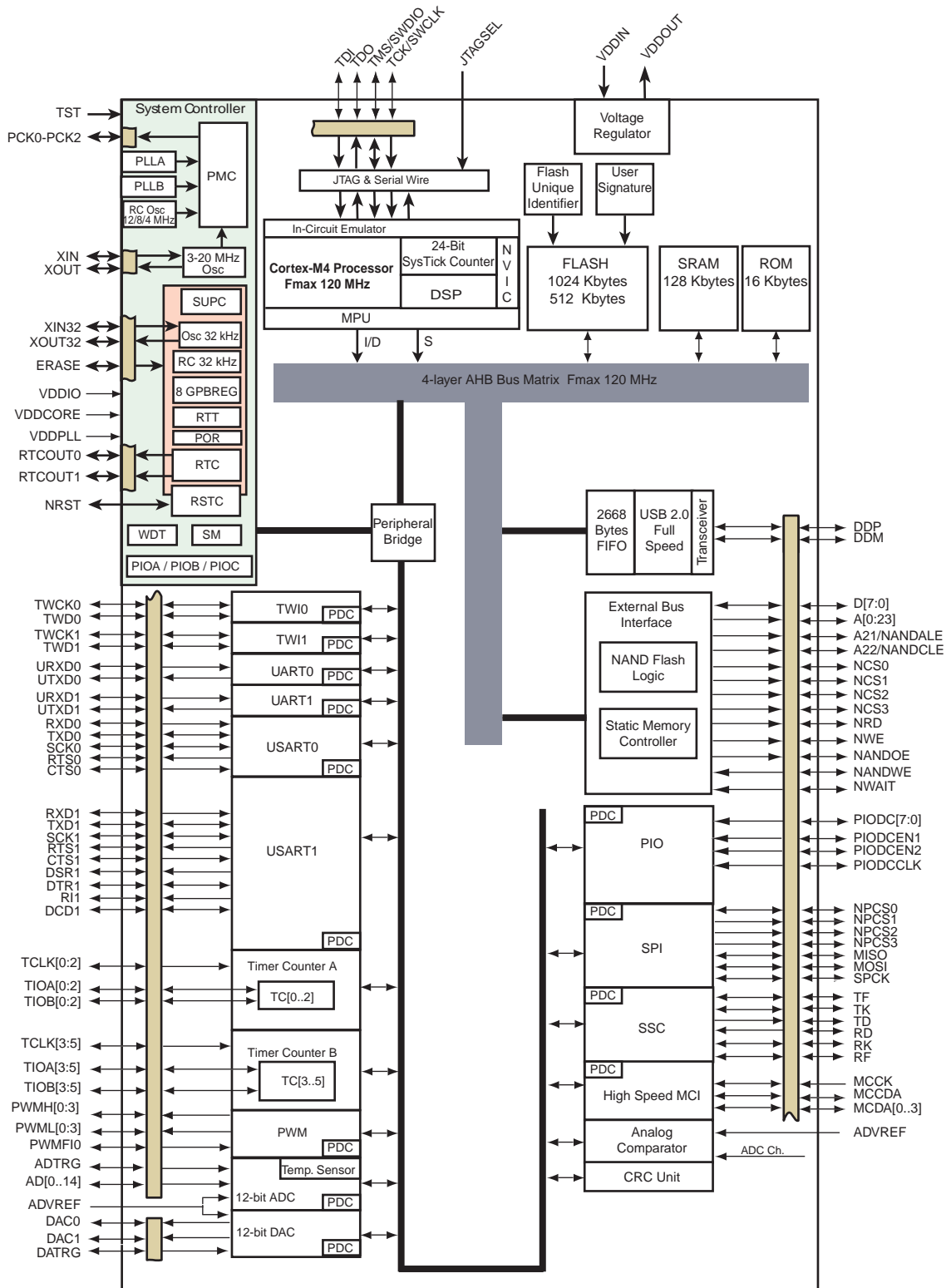

Figure 2-2. SAM4S16, S8 Series 64-pin version Block Diagram

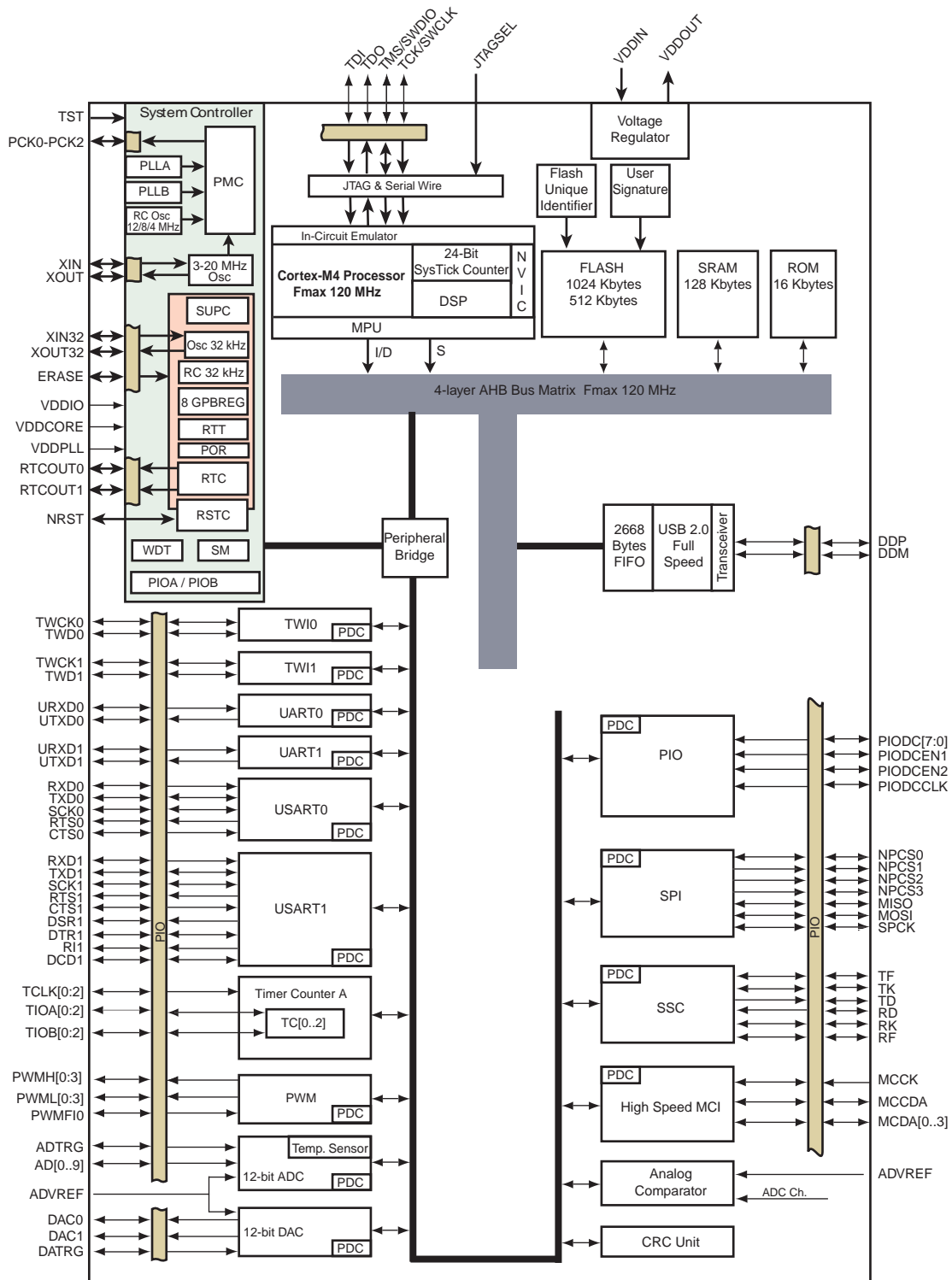
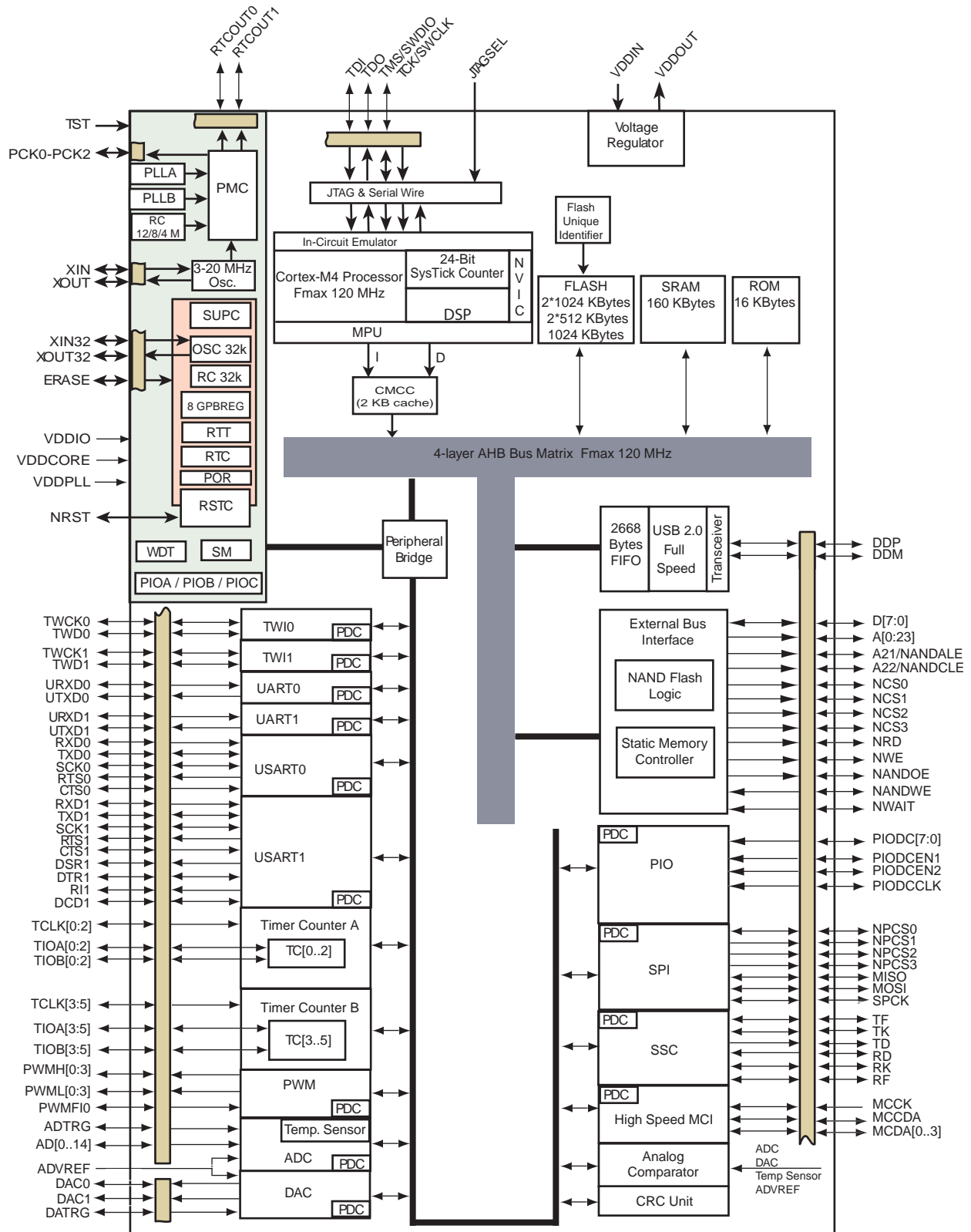

Figure 2-3. SAM4SD32, SD16, SA16 100-pin version Block Diagram



3. Signal Description

Table 3-1 gives details on signal names classified by peripheral.

Table 3-1. Signal Description List

Signal Name	Function	Type	Active Level	Voltage reference	Comments
Power Supplies					
VDDIO	Peripherals I/O Lines and USB transceiver Power Supply	Power			1.62V to 3.6V
VDDIN	Voltage Regulator Input, ADC, DAC and Analog Comparator Power Supply	Power			1.62V to 3.6V ⁽⁴⁾
VDDOUT	Voltage Regulator Output	Power			1.2V Output
VDDPLL	Oscillator and PLL Power Supply	Power			1.08 V to 1.32V
VDDCORE	Power the core, the embedded memories and the peripherals	Power			1.08V to 1.32V
GND	Ground	Ground			
Clocks, Oscillators and PLLs					
XIN	Main Oscillator Input	Input		VDDIO	Reset State: - PIO Input - Internal Pull-up disabled - Schmitt Trigger enabled ⁽¹⁾
XOUT	Main Oscillator Output	Output			
XIN32	Slow Clock Oscillator Input	Input			
XOUT32	Slow Clock Oscillator Output	Output			
PCK0 - PCK2	Programmable Clock Output	Output			Reset State: - PIO Input - Internal Pull-up enabled - Schmitt Trigger enabled ⁽¹⁾
Real Time Clock					
RTCOUT0	Programmable RTC waveform output	Output		VDDIO	Reset State: - PIO Input - Internal Pull-up enabled - Schmitt Trigger enabled ⁽¹⁾
RTCOUT1	Programmable RTC waveform output	Output			
Serial Wire/JTAG Debug Port - SWJ-DP					
TCK/SWCLK	Test Clock/Serial Wire Clock	Input		VDDIO	Reset State: - SWJ-DP Mode - Internal pull-up disabled ⁽⁵⁾ - Schmitt Trigger enabled ⁽¹⁾
TDI	Test Data In	Input			
TDO/TRACESWO	Test Data Out / Trace Asynchronous Data Out	Output			
TMS/SWDIO	Test Mode Select /Serial Wire Input/Output	Input / I/O			
JTAGSEL	JTAG Selection	Input	High		Permanent Internal pull-down

Table 3-1. Signal Description List (Continued)

Signal Name	Function	Type	Active Level	Voltage reference	Comments
Flash Memory					
ERASE	Flash and NVM Configuration Bits Erase Command	Input	High	VDDIO	Reset State: - Erase Input - Internal pull-down enabled - Schmitt Trigger enabled ⁽¹⁾
Reset/Test					
NRST	Synchronous Microcontroller Reset	I/O	Low	VDDIO	Permanent Internal pull-up
TST	Test Select	Input			Permanent Internal pull-down
Universal Asynchronous Receiver Transceiver - UARTx					
URXDx	UART Receive Data	Input			
UTXDx	UART Transmit Data	Output			
PIO Controller - PIOA - PIOB - PIOC					
PA0 - PA31	Parallel IO Controller A	I/O		VDDIO	Reset State: - PIO or System IOs ⁽²⁾ - Internal pull-up enabled - Schmitt Trigger enabled ⁽¹⁾
PB0 - PB14	Parallel IO Controller B	I/O			
PC0 - PC31	Parallel IO Controller C	I/O			
PIO Controller - Parallel Capture Mode					
PIODC0-PIODC7	Parallel Capture Mode Data	Input		VDDIO	
PIODCCLK	Parallel Capture Mode Clock	Input			
PIODCEN1-2	Parallel Capture Mode Enable	Input			
External Bus Interface					
D0 - D7	Data Bus	I/O			
A0 - A23	Address Bus	Output			
NWAIT	External Wait Signal	Input	Low		
Static Memory Controller - SMC					
NCS0 - NCS3	Chip Select Lines	Output	Low		
NRD	Read Signal	Output	Low		
NWE	Write Enable	Output	Low		
NAND Flash Logic					
NANDOE	NAND Flash Output Enable	Output	Low		
NANDWE	NAND Flash Write Enable	Output	Low		
High Speed Multimedia Card Interface - HSMCI					
MCCK	Multimedia Card Clock	I/O			
MCCDA	Multimedia Card Slot A Command	I/O			
MCDA0 - MCDA3	Multimedia Card Slot A Data	I/O			

Table 3-1. Signal Description List (Continued)

Signal Name	Function	Type	Active Level	Voltage reference	Comments
Universal Synchronous Asynchronous Receiver Transmitter USARTx					
SCKx	USARTx Serial Clock	I/O			
TXDx	USARTx Transmit Data	I/O			
RXDx	USARTx Receive Data	Input			
RTSx	USARTx Request To Send	Output			
CTSx	USARTx Clear To Send	Input			
DTR1	USART1 Data Terminal Ready	I/O			
DSR1	USART1 Data Set Ready	Input			
DCD1	USART1 Data Carrier Detect	Output			
RI1	USART1 Ring Indicator	Input			
Synchronous Serial Controller - SSC					
TD	SSC Transmit Data	Output			
RD	SSC Receive Data	Input			
TK	SSC Transmit Clock	I/O			
RK	SSC Receive Clock	I/O			
TF	SSC Transmit Frame Sync	I/O			
RF	SSC Receive Frame Sync	I/O			
Timer/Counter - TC					
TCLKx	TC Channel x External Clock Input	Input			
TIOAx	TC Channel x I/O Line A	I/O			
TIOBx	TC Channel x I/O Line B	I/O			
Pulse Width Modulation Controller- PWMC					
PWMHx	PWM Waveform Output High for channel x	Output			
PWMLx	PWM Waveform Output Low for channel x	Output			only output in complementary mode when dead time insertion is enabled.
PWMFIO	PWM Fault Input	Input			
Serial Peripheral Interface - SPI					
MISO	Master In Slave Out	I/O			
MOSI	Master Out Slave In	I/O			
SPCK	SPI Serial Clock	I/O			
SPI_NPCS0	SPI Peripheral Chip Select 0	I/O	Low		
SPI_NPCS1 - SPI_NPCS3	SPI Peripheral Chip Select	Output	Low		

Table 3-1. Signal Description List (Continued)

Signal Name	Function	Type	Active Level	Voltage reference	Comments
Two-Wire Interface- TWI					
TWDx	TWlX Two-wire Serial Data	I/O			
TWCKx	TWlX Two-wire Serial Clock	I/O			
Analog					
ADVREF	ADC, DAC and Analog Comparator Reference	Analog			
12-bit Analog-to-Digital Converter - ADC					
AD0-AD14	Analog Inputs	Analog, Digital			
ADTRG	ADC Trigger	Input		VDDIO	
12-bit Digital-to-Analog Converter - DAC					
DAC0 - DAC1	Analog output	Analog, Digital			
DACTRG	DAC Trigger	Input		VDDIO	
Fast Flash Programming Interface - FFPI					
PGMEN0-PGMEN2	Programming Enabling	Input		VDDIO	
PGMM0-PGMM3	Programming Mode	Input		VDDIO	
PGMD0-PGMD15	Programming Data	I/O			
PGMRDY	Programming Ready	Output	High		
PGMNVALID	Data Direction	Output	Low		
PGMNOE	Programming Read	Input	Low		
PGMCK	Programming Clock	Input			
PGMNCMD	Programming Command	Input	Low		
USB Full Speed Device					
DDM	USB Full Speed Data -	Analog, Digital		VDDIO	Reset State: - USB Mode - Internal Pull-down ⁽³⁾
DDP	USB Full Speed Data +				

- Note:
1. Schmitt Triggers can be disabled through PIO registers.
 2. Some PIO lines are shared with System I/Os.
 3. Refer to USB Section of the product Electrical Characteristics for information on Pull-down value in USB Mode.
 4. See “Typical Powering Schematics” Section for restrictions on voltage range of Analog Cells.
 5. TDO pin is set in input mode when the Cortex-M4 Core is not in debug mode. Thus the internal pull-up corresponding to this PIO line must be enabled to avoid current consumption due to floating input

4. Package and Pinout

SAM4S devices are pin-to-pin compatible with SAM3N, SAM3S products in 64- and 100-pin versions, and AT91SAM7S legacy products in 64-pin versions.

4.1 SAM4SD32/SD16/SA16/S16/S8C Package and Pinout

4.1.1 100-Lead LQFP Package Outline

Figure 4-1. Orientation of the 100-lead LQFP Package

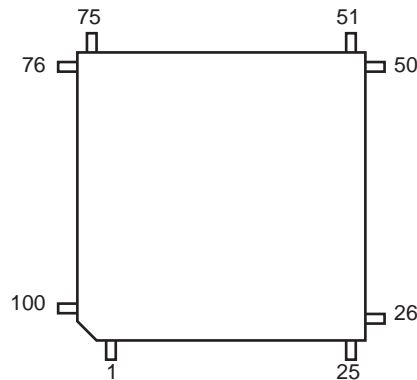

4.1.2 100-ball TFBGA Package Outline

The 100-Ball TFBGA package has a 0.8 mm ball pitch and respects Green Standards. Its dimensions are 9 x 9 x 1.1 mm. [Figure 4-2](#) shows the orientation of the 100-ball TFBGA Package.

Figure 4-2. Orientation of the 100-ball TFBGA Package

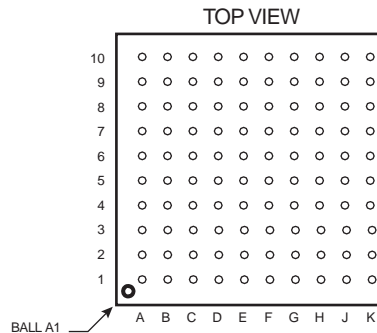

4.1.3 100-ball VFBGA Package Outline

Figure 4-3. Orientation of the 100-ball VFBGA Package

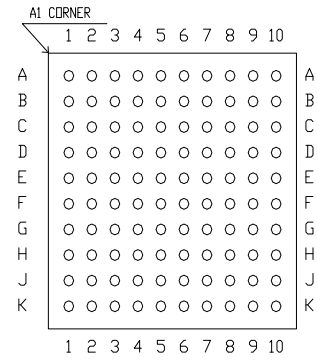

4.1.4 100-Lead LQFP Pinout

Table 4-1. SAM4SD32/SD16/SA16/S16/S8C 100-lead LQFP pinout

1	ADVREF	26	GND	51	TDI/PB4	76	TDO/TRACESWO/ PB5
2	GND	27	VDDIO	52	PA6/PGMNOE	77	JTAGSEL
3	PB0/AD4	28	PA16/PGMD4	53	PA5/PGMRDY	78	PC18
4	PC29/AD13	29	PC7	54	PC28	79	TMS/SWDIO/PB6
5	PB1/AD5	30	PA15/PGMD3	55	PA4/PGMNCMD	80	PC19
6	PC30/AD14	31	PA14/PGMD2	56	VDDCORE	81	PA31
7	PB2/AD6	32	PC6	57	PA27/PGMD15	82	PC20
8	PC31	33	PA13/PGMD1	58	PC8	83	TCK/SWCLK/PB7
9	PB3/AD7	34	PA24/PGMD12	59	PA28	84	PC21
10	VDDIN	35	PC5	60	NRST	85	VDDCORE
11	VDDOUT	36	VDDCORE	61	TST	86	PC22
12	PA17/PGMD5/ AD0	37	PC4	62	PC9	87	ERASE/PB12
13	PC26	38	PA25/PGMD13	63	PA29	88	DDM/PB10
14	PA18/PGMD6/ AD1	39	PA26/PGMD14	64	PA30	89	DDP/PB11
15	PA21/PGMD9/ AD8	40	PC3	65	PC10	90	PC23
16	VDDCORE	41	PA12/PGMD0	66	PA3	91	VDDIO
17	PC27	42	PA11/PGMM3	67	PA2/PGMEN2	92	PC24
18	PA19/PGMD7/ AD2	43	PC2	68	PC11	93	PB13/DAC0
19	PC15/AD11	44	PA10/PGMM2	69	VDDIO	94	PC25
20	PA22/PGMD10/ AD9	45	GND	70	GND	95	GND
21	PC13/AD10	46	PA9/PGMM1	71	PC14	96	PB8/XOUT
22	PA23/PGMD11	47	PC1	72	PA1/PGMEN1	97	PB9/PGMCK/XIN
23	PC12/AD12	48	PA8/XOUT32/ PGMM0	73	PC16	98	VDDIO
24	PA20/PGMD8/ AD3	49	PA7/XIN32/ PGMINVALID	74	PA0/PGMEN0	99	PB14/DAC1
25	PC0	50	VDDIO	75	PC17	100	VDDPLL

4.1.5 100-Ball TFBGA Pinout

Table 4-2. SAM4SD32/SD16/SA16/S16/S8 100-ball TFBGA pinout

A1	PB1/AD5	C6	TCK/SWCLK/PB7	F1	PA18/PGMD6/ AD1	H6	PC4
A2	PC29	C7	PC16	F2	PC26	H7	PA11/PGMM3
A3	VDDIO	C8	PA1/PGMEN1	F3	VDDOUT	H8	PC1
A4	PB9/PGMCK/XIN	C9	PC17	F4	GND	H9	PA6/PGMNOE
A5	PB8/XOUT	C10	PA0/PGMEN0	F5	VDDIO	H10	TDI/PB4
A6	PB13/DAC0	D1	PB3/AD7	F6	PA27/PGMD15	J1	PC15/AD11
A7	DDP/PB11	D2	PB0/AD4	F7	PC8	J2	PC0
A8	DDM/PB10	D3	PC24	F8	PA28	J3	PA16/PGMD4
A9	TMS/SWDIO/PB6	D4	PC22	F9	TST	J4	PC6
A10	JTAGSEL	D5	GND	F10	PC9	J5	PA24/PGMD12
B1	PC30	D6	GND	G1	PA21/PGMD9/AD8	J6	PA25/PGMD13
B2	ADVREF	D7	VDDCORE	G2	PC27	J7	PA10/PGMM2
B3	GNDANA	D8	PA2/PGMEN2	G3	PA15/PGMD3	J8	GND
B4	PB14/DAC1	D9	PC11	G4	VDDCORE	J9	VDDCORE
B5	PC21	D10	PC14	G5	VDDCORE	J10	VDDIO
B6	PC20	E1	PA17/PGMD5/ AD0	G6	PA26/PGMD14	K1	PA22/PGMD10/ AD9
B7	PA31	E2	PC31	G7	PA12/PGMD0	K2	PC13/AD10
B8	PC19	E3	VDDIN	G8	PC28	K3	PC12/AD12
B9	PC18	E4	GND	G9	PA4/PGMNCMD	K4	PA20/PGMD8/ AD3
B10	TDO/TRACESWO/ PB5	E5	GND	G10	PA5/PGMRDY	K5	PC5
C1	PB2/AD6	E6	NRST	H1	PA19/PGMD7/ AD2	K6	PC3
C2	VDDPLL	E7	PA29/AD13	H2	PA23/PGMD11	K7	PC2
C3	PC25	E8	PA30/AD14	H3	PC7	K8	PA9/PGMM1
C4	PC23	E9	PC10	H4	PA14/PGMD2	K9	PA8/XOUT32/ PGMM0
C5	ERASE/PB12	E10	PA3	H5	PA13/PGMD1	K10	PA7/XIN32/ PGMINVALID

4.1.6 100-Ball VFBGA Pinout

Table 4-3. SAM4SD32/SD16/SA16/S16/S8 100-ball VFBGA pinout

A1	ADVREF	C6	PC9	F1	VDDOUT	H6	PA12/PGMD0
A2	VDDPLL	C7	TMS/SWDIO/PB6	F2	PA18/PGMD6/ AD1	H7	PA9/PGMM1
A3	PB9/PGMCK/XIN	C8	PA1/PGMEN1	F3	PA17/PGMD5/ AD0	H8	VDDCORE
A4	PB8/XOUT	C9	PA0/PGMEN0	F4	GND	H9	PA6/PGMNOE
A5	JTAGSEL	C10	PC16	F5	GND	H10	PA5/PGMRDY
A6	DDP/PB11	D1	PB1/AD5	F6	PC26	J1	PA20/AD3
A7	DDM/PB10	D2	PC30	F7	PA4/PGMNCMD	J2	PC12/AD12
A8	PC20	D3	PC31	F8	PA28	J3	PA16/PGMD4
A9	PC19	D4	PC22	F9	TST	J4	PC6
A10	TDO/TRACESWO/ PB5	D5	PC5	F10	PC8	J5	PA24
B1	GNDANA	D6	PA29/AD13	G1	PC15/AD11	J6	PA25
B2	PC25	D7	PA30/AD14	G2	PA19/PGMD7/ AD2	J7	PA11/PGMM3
B3	PB14/DAC1	D8	GND	G3	PA21/AD8	J8	VDDCORE
B4	PB13/DAC0	D9	PC14	G4	PA15/PGMD3	J9	VDDCORE
B5	PC23	D10	PC11	G5	PC3	J10	TDI/PB4
B6	PC21	E1	VDDIN	G6	PA10/PGMM2	K1	PA23
B7	TCK/SWCLK/PB7	E2	PB3/AD7	G7	PC1	K2	PC0
B8	PA31	E3	PB2/AD6	G8	PC28	K3	PC7
B9	PC18	E4	GND	G9	NRST	K4	PA13/PGMD1
B10	PC17	E5	GND	G10	PA27	K5	PA26
C1	PB0/AD4	E6	GND	H1	PC13/AD10	K6	PC2
C2	PC29	E7	VDDIO	H2	PA22/AD9	K7	VDDIO
C3	PC24	E8	PC10	H3	PC27	K8	VDDIO
C4	ERASE/PB12	E9	PA2/PGMEN2	H4	PA14/PGMD2	K9	PA8/XOUT32/ PGMM0
C5	VDDCORE	E10	PA3	H5	PC4	K10	PA7/XIN32/ PGMNVALID

4.2 SAM4SD32/SD16/SA16/S16/S8 Package and Pinout

4.2.1 64-Lead LQFP Package Outline

Figure 4-4. Orientation of the 64-lead LQFP Package

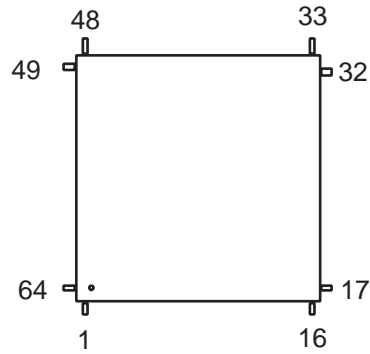

4.2.2 64-lead QFN Package Outline

Figure 4-5. Orientation of the 64-lead QFN Package

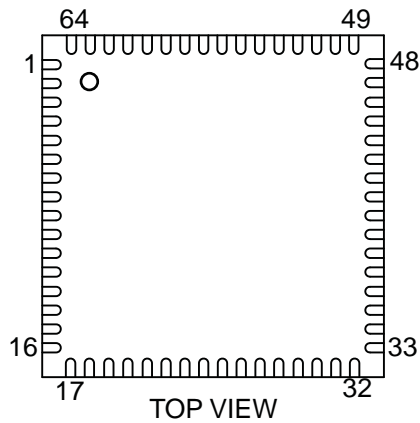

4.2.3 64-Lead LQFP and QFN Pinout

Table 4-4. 64-pin SAM4SD32/SD16/SA16/S16/S8 pinout

1	ADVREF	17	GND	33	TDI/PB4	49	TDO/TRACESWO/ PB5
2	GND	18	VDDIO	34	PA6/PGMNOE	50	JTAGSEL
3	PB0/AD4	19	PA16/PGMD4	35	PA5/PGMRDY	51	TMS/SWDIO/PB6
4	PB1/AD5	20	PA15/PGMD3	36	PA4/PGMNCMD	52	PA31
5	PB2/AD6	21	PA14/PGMD2	37	PA27/PGMD15	53	TCK/SWCLK/PB7
6	PB3/AD7	22	PA13/PGMD1	38	PA28	54	VDDCORE
7	VDDIN	23	PA24/PGMD12	39	NRST	55	ERASE/PB12
8	VDDOUT	24	VDDCORE	40	TST	56	DDM/PB10
9	PA17/PGMD5/ AD0	25	PA25/PGMD13	41	PA29	57	DDP/PB11
10	PA18/PGMD6/ AD1	26	PA26/PGMD14	42	PA30	58	VDDIO
11	PA21/PGMD9/ AD8	27	PA12/PGMD0	43	PA3	59	PB13/DAC0
12	VDDCORE	28	PA11/PGMM3	44	PA2/PGMEN2	60	GND
13	PA19/PGMD7/ AD2	29	PA10/PGMM2	45	VDDIO	61	XOUT/PB8
14	PA22/PGMD10/ AD9	30	PA9/PGMM1	46	GND	62	XIN/PGMCK/PB9
15	PA23/PGMD11	31	PA8/XOUT32/ PGMM0	47	PA1/PGMEN1	63	PB14/DAC1
16	PA20/PGMD8/ AD3	32	PA7/XIN32/ PGMINVALID	48	PA0/PGMEN0	64	VDDPLL

Note: The bottom pad of the QFN package must be connected to ground.

5. Power Considerations

5.1 Power Supplies

The SAM4S has several types of power supply pins:

- VDDCORE pins: Power the core, the embedded memories and the peripherals. Voltage ranges from 1.08V to 1.32V.
- VDDIO pins: Power the Peripherals I/O lines (Input/Output Buffers), USB transceiver, Backup part, 32 kHz crystal oscillator and oscillator pads. Voltage ranges from 1.62V to 3.6V.
- VDDIN pin: Voltage Regulator Input, ADC, DAC and Analog Comparator Power Supply. Voltage ranges from 1.62V to 3.6V.
- VDDPLL pin: Powers the PLLA, PLLB, the Fast RC and the 3 to 20 MHz oscillator. Voltage ranges from 1.08V to 1.32V.

5.2 Voltage Regulator

The SAM4S embeds a voltage regulator that is managed by the Supply Controller.

This internal regulator is designed to supply the internal core of SAM4S. It features two operating modes:

- In Normal mode, the voltage regulator consumes less than 500 μ A static current and draws 80 mA of output current. Internal adaptive biasing adjusts the regulator quiescent current depending on the required load current. In Wait Mode quiescent current is only 5 μ A.
- In Backup mode, the voltage regulator consumes less than 1 μ A while its output (VDDOUT) is driven internally to GND. The default output voltage is 1.20V and the start-up time to reach Normal mode is less than 300 μ s.

For adequate input and output power supply decoupling/bypassing, refer to the “Voltage Regulator” section in the “Electrical Characteristics” section of the datasheet.

5.3 Typical Powering Schematics

The SAM4S supports a 1.62V-3.6V single supply mode. The internal regulator input is connected to the source and its output feeds VDDCORE. [Figure 5-1](#) below shows the power schematics.

As VDDIN powers the voltage regulator, the ADC, DAC and the analog comparator, when the user does not want to use the embedded voltage regulator, it can be disabled by software via the SUPC (note that this is different from Backup mode).

Figure 5-1. Single Supply

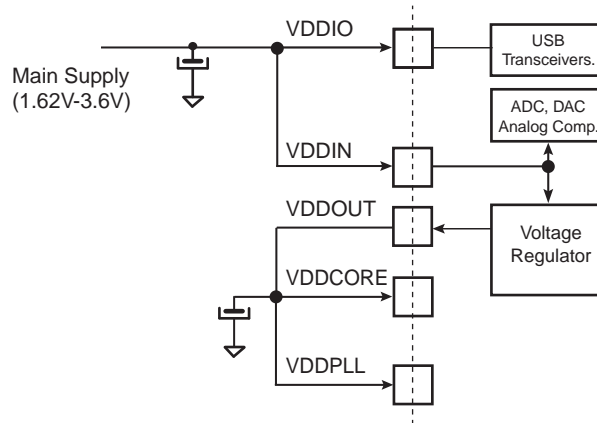

Note: Restrictions
 For USB, VDDIO needs to be greater than 3.0V.
 For ADC, VDDIN needs to be greater than 2.0V.
 For DAC, VDDIN needs to be greater than 2.4V.

Figure 5-2. Core Externally Supplied

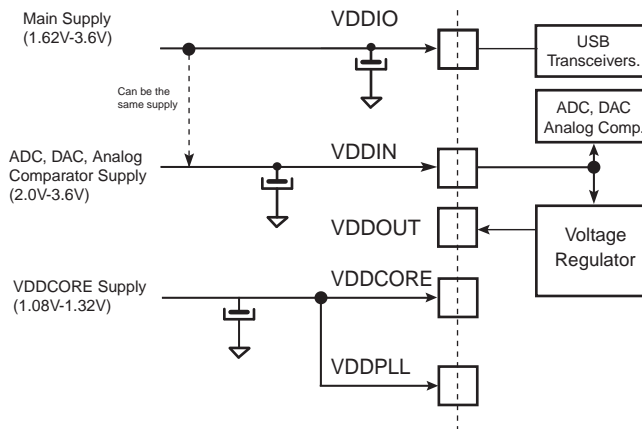

Note: Restrictions
 For USB, VDDIO needs to be greater than 3.0V.
 For ADC, VDDIN needs to be greater than 2.0V.
 For DAC, VDDIN needs to be greater than 2.4V.

Figure 5-3 below provides an example of the powering scheme when using a backup battery. Since the PIO state is preserved when in backup mode, any free PIO line can be used to switch off the external regulator by driving the PIO line at low level (PIO is input, pull-up enabled after backup reset). External wake-up of the system can be from a push button or any signal. See Section 5.6 “Wake-up Sources” for further details.

Figure 5-3. Backup Battery

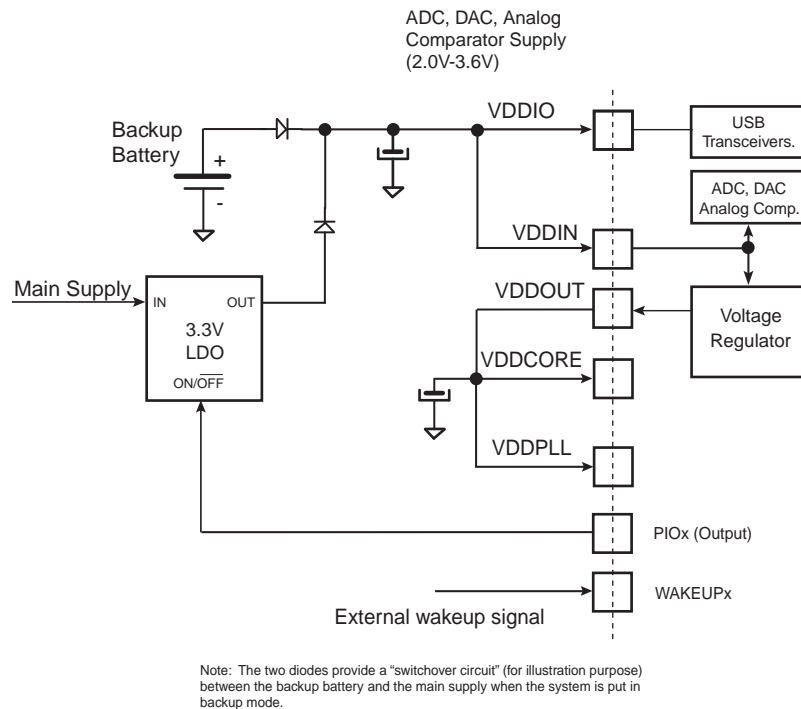

5.4 Active Mode

Active mode is the normal running mode with the core clock running from the fast RC oscillator, the main crystal oscillator or the PLLA. The power management controller can be used to adapt the frequency and to disable the peripheral clocks.

5.5 Low-power Modes

The various low-power modes of the SAM4S are described below:

5.5.1 Backup Mode

The purpose of backup mode is to achieve the lowest power consumption possible in a system which is performing periodic wake-ups to perform tasks but not requiring fast startup time. Total current consumption is 1 μ A typical ($V_{DDIO} = 1.8$ V to 25°).

The Supply Controller, zero-power power-on reset, RTT, RTC, Backup registers and 32 kHz oscillator (RC or crystal oscillator selected by software in the Supply Controller) are running. The regulator and the core supply are off.

Backup mode is based on the Cortex-M4 deep sleep mode with the voltage regulator disabled.

The SAM4S can be awakened from this mode through WUP0-15 pins, the supply monitor (SM), the RTT or RTC wake-up event.

Backup mode is entered by writing the Supply Controller Control Register (SUPC_CR) with the VROFF bit at 1 (A key is needed to write the VROFF bit, please refer to Supply Controller SUPC section of the product datasheet) and with the SLEEPDEEP bit in the Cortex-M4 System Control Register set to 1. (See the Power management description in The ARM Cortex-M4 Processor section of the product datasheet).

Entering Backup mode:

- Set the SLEEPDEEP bit of Cortex_M4 to 1
- Set the VROFF bit of SUPC_CR to 1

Exit from Backup mode happens if one of the following enable wake up events occurs:

- WKUPEN0-15 pins (level transition, configurable debouncing)
- Supply Monitor alarm
- RTC alarm
- RTT alarm

5.5.2 Wait Mode

The purpose of the wait mode is to achieve very low power consumption while maintaining the whole device in a powered state for a startup time of less than 10 μ s. Current Consumption in Wait mode is typically 32 μ A (total current consumption) if the internal voltage regulator is used.

In this mode, the clocks of the core, peripherals and memories are stopped. However, the core, peripherals and memories power supplies are still powered. From this mode, a fast start up is available.

This mode is entered by setting WAITMODE bit to 1 (in PMC clock generator Main Oscillator register) with LPM = 1 (Low Power Mode bit in PMC_FSMR) and with FLPM = 00 or FLPM=01 (Flash Low Power Mode bits in PMC_FSMR).

The Cortex-M4 is able to handle external events or internal events in order to wake-up the core. This is done by configuring the external lines WUP0-15 as fast startup wake-up pins (refer to [Section 5.7 “Fast Startup”](#)). RTC or RTT Alarm and USB wake-up events can be used to wake up the CPU.

Entering Wait Mode:

- Select the 4/8/12 MHz fast RC oscillator as Main Clock
- Set the LPM bit in the PMC Fast Startup Mode Register (PMC_FSMR)
- Set the FLPM bitfield in the PMC Fast Startup Mode Register (PMC_FSMR)
- Set Flash Wait State at 0.
- Set the WAITMODE bit = 1 in PMC Main Oscillator Register (CKGR_MOR)
- Wait for Master Clock Ready MCKRDY = 1 in the PMC Status Register (PMC_SR)

Note: Internal Main clock resynchronization cycles are necessary between the writing of MOSRCEN bit and the effective entry in Wait mode. Depending on the user application, waiting for MOSRCEN bit to be cleared is recommended to ensure that the core will not execute undesired instructions.

Depending on Flash Low Power Mode (FLPM) value, the Flash will enter in three different modes:

- FLPM[00] in Standby mode
- FLPM[01] in Deep Power Down mode
- FLPM[10] in Idle mode.

Following the Flash mode selection, the consumption in wait mode will decrease. In Deep Power

Down mode the recovery time of the Flash in Standby mode will be less than the power up delay.

5.5.3 Sleep Mode

The purpose of sleep mode is to optimize power consumption of the device versus response time. In this mode, only the core clock is stopped. The peripheral clocks can be enabled. The current consumption in this mode is application dependent.

This mode is entered via Wait for Interrupt (WFI) instructions with LPM = 0 in PMC_FSMR.

The processor can be awakened from an interrupt if WFI instruction of the Cortex-M4 is used.

5.5.4 Low Power Mode Summary Table

The modes detailed above are the main low-power modes. Each part can be set to on or off separately and wake up sources can be individually configured. [Table 5-1](#) below shows a summary of the configurations of the low-power modes.

Table 5-1. Low-power Mode Configuration Summary

Mode	SUPC, 32 kHz Osc, RTC, RTT Backup Registers, POR (Backup Region)	Regulator	Core Memory Peripherals	Mode Entry	Potential Wake Up Sources	Core at Wake Up	PIO State while in Low Power Mode	PIO State at Wake Up	Consumption ^{(1) (2)}	Wake-up Time ⁽³⁾
Backup Mode	ON	OFF	OFF (Not powered)	VROFF bit = 1 +SLEEPDEEP bit = 1	WUP0-15 pins SM alarm RTC alarm RTT alarm	Reset	Previous state saved	PIOA & PIOB & PIOC Inputs with pull ups	1 μ A typ ⁽⁴⁾	300 ms
Wait Mode w/Flash in Standby mode	ON	ON	Powered (Not clocked)	WAITMODE bit = 1 +SLEEPDEEP bit = 0 +LPM bit = 1 FLPM0 bit = 0 FLPM1 bit = 0	Any Event from: Fast startup through WUP0-15 pins RTC alarm RTT alarm USB wake-up	Clocked back	Previous state saved	Unchanged	32.2 μ A ⁽⁵⁾	< 10 μ s
Wait Mode w/Flash in Deep Power Down mode	ON	ON	Powered (Not clocked)	WAITMODE bit = 1 +SLEEPDEEP bit = 0 +LPM bit = 1 FLPM0 bit = 0 FLPM1 bit = 1	Any Event from: Fast startup through WUP0-15 pins RTC alarm RTT alarm USB wake-up	Clocked back	Previous state saved	Unchanged	27.6 μ A	< 10 μ s
Sleep Mode	ON	ON	Powered ⁽⁶⁾ (Not clocked)	WFI +SLEEPDEEP bit = 0 +LPM bit = 0	Entry mode =WFI Interrupt Only; Any Enabled Interrupt	Clocked back	Previous state saved	Unchanged ⁽⁷⁾	⁽⁷⁾	⁽⁷⁾

- Notes:
1. The external loads on PIOs are not taken into account in the calculation.
 2. Supply Monitor current consumption is not included.
 3. When considering wake-up time, the time required to start the PLL is not taken into account. Once started, the device works with the 4/8/12 MHz fast RC oscillator. The user has to add the PLL start-up time if it is needed in the system. The wake-up time is defined as the time taken for wake up until the first instruction is fetched.
 4. Total consumption 1 μ A typ to 1.8V on VDDIO to 25°C.
 5. 20.4 μ A on VDDCORE, 32.2 μ A for total current consumption.
 6. Depends on MCK frequency.
 7. Depends on MCK frequency. In this mode, the core is supplied but some peripherals can be clocked.

5.6 Wake-up Sources

The wake-up events allow the device to exit the backup mode. When a wake-up event is detected, the Supply Controller performs a sequence which automatically reenables the core power supply and the SRAM power supply, if they are not already enabled.

Figure 5-4. Wake-up Source

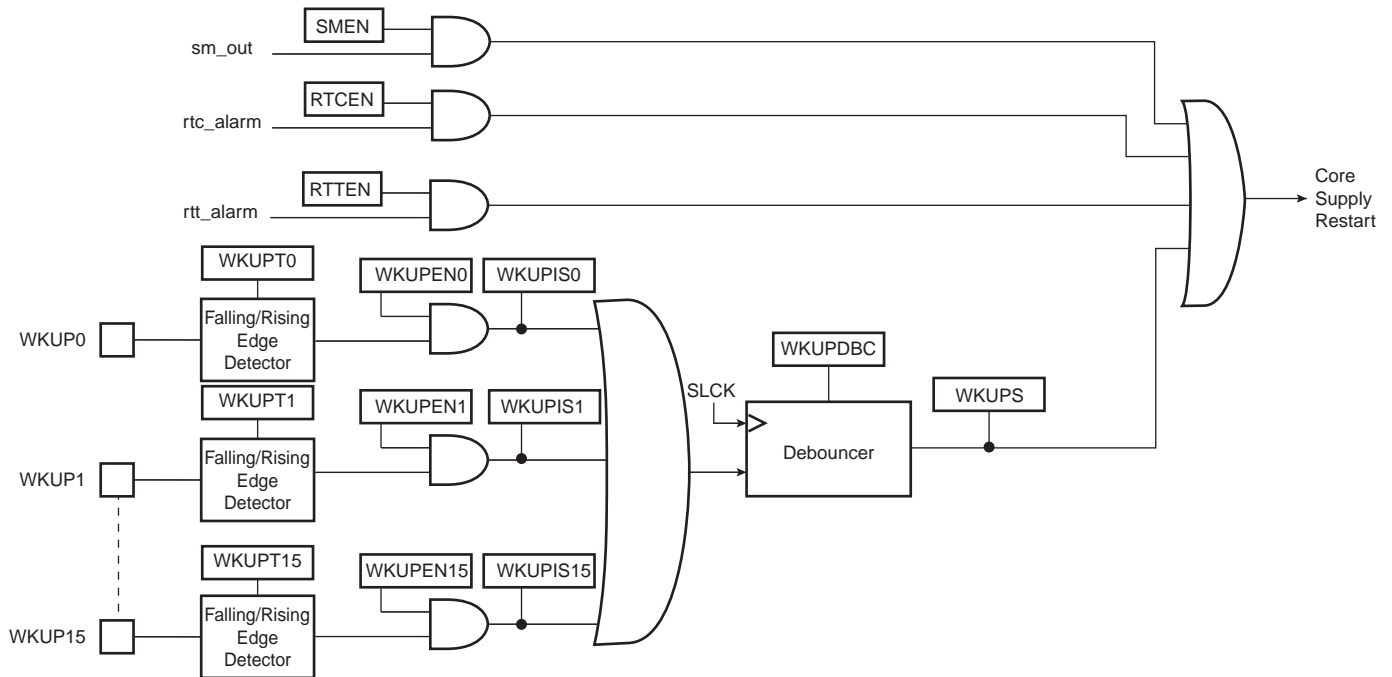

5.7 Fast Startup

The SAM4S allows the processor to restart in a few microseconds while the processor is in wait mode or in sleep mode. A fast start up can occur upon detection of a low level on one of the 19 wake-up inputs (WKUP0 to 15 + SM + RTC + RTT).

The fast restart circuitry, as shown in Figure 5-5, is fully asynchronous and provides a fast start-up signal to the Power Management Controller. As soon as the fast start-up signal is asserted, the PMC automatically restarts the embedded 4/8/12 MHz Fast RC oscillator, switches the master clock on this 4 MHz clock and reenables the processor clock.

Figure 5-5. Fast Start-Up Sources

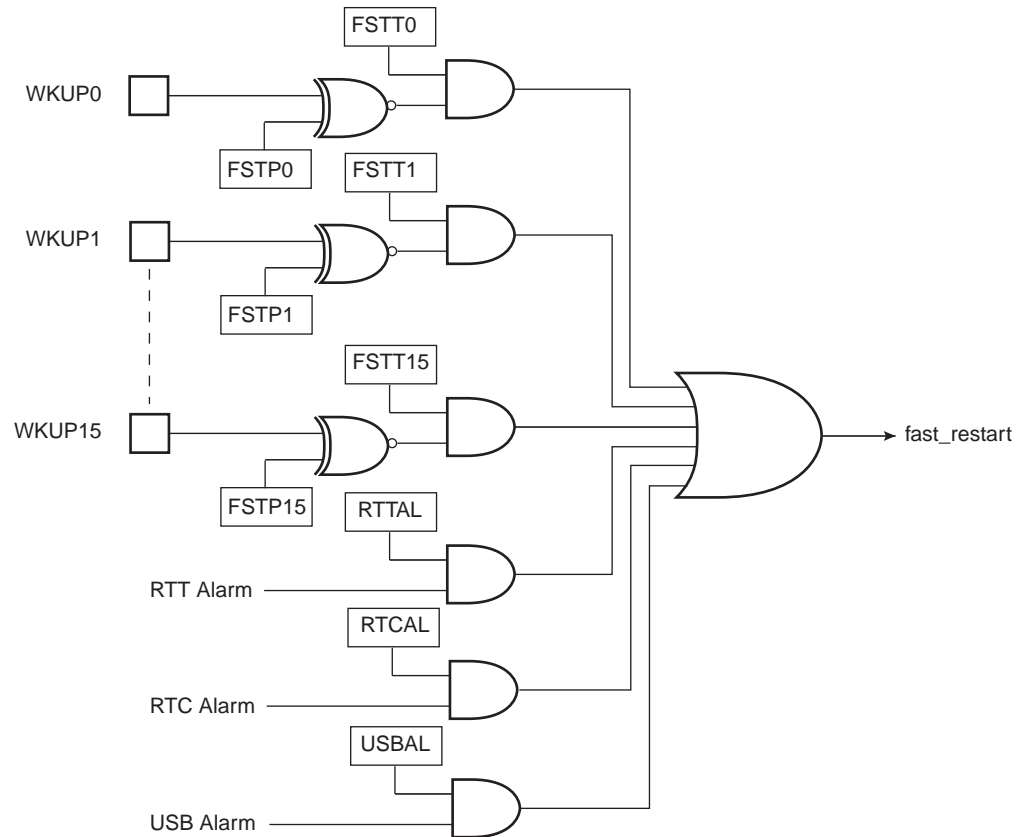

6. Input/Output Lines

The SAM4S has several kinds of input/output (I/O) lines such as general purpose I/Os (GPIO) and system I/Os. GPIOs can have alternate functionality due to multiplexing capabilities of the PIO controllers. The same PIO line can be used whether in I/O mode or by the multiplexed peripheral. System I/Os include pins such as test pins, oscillators, erase or analog inputs.

6.1 General Purpose I/O Lines

GPIO Lines are managed by PIO Controllers. All I/Os have several input or output modes such as pull-up or pull-down, input Schmitt triggers, multi-drive (open-drain), glitch filters, debouncing or input change interrupt. Programming of these modes is performed independently for each I/O line through the PIO controller user interface. For more details, refer to the product “PIO Controller” section.

The input/output buffers of the PIO lines are supplied through VDDIO power supply rail.

The SAM4S embeds high speed pads able to handle up to 70 MHz for HSMCI (MCK/2), 70 MHz for SPI clock lines and 46 MHz on other lines. See the “AC Characteristics” sub-section of the product Electrical Characteristics. Typical pull-up and pull-down value is 100 kΩ for all I/Os.

Each I/O line also embeds an ODT (On-Die Termination), (see [Figure 6-1](#) below). It consists of an internal series resistor termination scheme for impedance matching between the driver output (SAM4S) and the PCB trace impedance preventing signal reflection. The series resistor helps to reduce IOs switching current (di/dt) thereby reducing in turn, EMI. It also decreases overshoot and undershoot (ringing) due to inductance of interconnect between devices or between boards. In conclusion ODT helps diminish signal integrity issues.

Figure 6-1. On-Die Termination

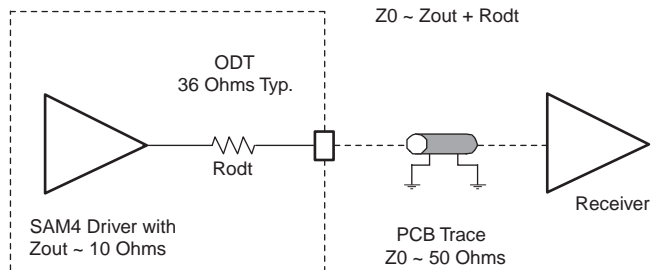

6.2 System I/O Lines

System I/O lines are pins used by oscillators, test mode, reset and JTAG to name but a few. Described below in [Table 6-1](#) are the SAM4S system I/O lines shared with PIO lines.

These pins are software configurable as general purpose I/O or system pins. At startup the default function of these pins is always used.

Table 6-1. System I/O Configuration Pin List.

SYSTEM_IO bit number	Default function after reset	Other function	Constraints for normal start	Configuration
12	ERASE	PB12	Low Level at startup ⁽¹⁾	In Matrix User Interface Registers (Refer to the System I/O Configuration Register in the “Bus Matrix” section of the datasheet.)
10	DDM	PB10	-	
11	DDP	PB11	-	
7	TCK/SWCLK	PB7	-	
6	TMS/SWDIO	PB6	-	
5	TDO/TRACESWO	PB5	-	
4	TDI	PB4	-	
-	PA7	XIN32	-	See footnote ⁽²⁾ below
-	PA8	XOUT32	-	
-	PB9	XIN	-	See footnote ⁽³⁾ below
-	PB8	XOUT	-	

- Notes:
1. If PB12 is used as PIO input in user applications, a low level must be ensured at startup to prevent Flash erase before the user application sets PB12 into PIO mode,
 2. In the product Datasheet Refer to: “Slow Clock Generator” of the “Supply Controller” section.
 3. In the product Datasheet Refer to: “3 to 20 MHZ Crystal Oscillator” information in the “PMC” section.

6.2.1 Serial Wire JTAG Debug Port (SWJ-DP) Pins

The SWJ-DP pins are TCK/SWCLK, TMS/SWDIO, TDO/SWO, TDI and commonly provided on a standard 20-pin JTAG connector defined by ARM. For more details about voltage reference and reset state, refer to [Table 3-1 on page 8](#).

At startup, SWJ-DP pins are configured in SWJ-DP mode to allow connection with debugging probe. Please refer to the “Debug and Test” Section of the product datasheet.

SWJ-DP pins can be used as standard I/Os to provide users more general input/output pins when the debug port is not needed in the end application. Mode selection between SWJ-DP mode (System IO mode) and general IO mode is performed through the AHB Matrix Special Function Registers (MATRIX_SFR). Configuration of the pad for pull-up, triggers, debouncing and glitch filters is possible regardless of the mode.

The JTAGSEL pin is used to select the JTAG boundary scan when asserted at a high level. It integrates a permanent pull-down resistor of about 15 kΩ to GND, so that it can be left unconnected for normal operations.

By default, the JTAG Debug Port is active. If the debugger host wants to switch to the Serial Wire Debug Port, it must provide a dedicated JTAG sequence on TMS/SWDIO and TCK/SWCLK which disables the JTAG-DP and enables the SW-DP. When the Serial Wire Debug Port is active, TDO/TRACESWO can be used for trace.

The asynchronous TRACE output (TRACESWO) is multiplexed with TDO. So the asynchronous trace can only be used with SW-DP, not JTAG-DP. For more information about SW-DP and JTAG-DP switching, please refer to the “Debug and Test” Section.

6.3 Test Pin

The TST pin is used for JTAG Boundary Scan Manufacturing Test or Fast Flash programming mode of the SAM4S series. The TST pin integrates a permanent pull-down resistor of about 15 k Ω to GND, so that it can be left unconnected for normal operations. To enter fast programming mode, see the Fast Flash Programming Interface (FFPI) section. For more on the manufacturing and test mode, refer to the “Debug and Test” section of the product datasheet.

6.4 NRST Pin

The NRST pin is bidirectional. It is handled by the on-chip reset controller and can be driven low to provide a reset signal to the external components or asserted low externally to reset the microcontroller. It will reset the Core and the peripherals except the Backup region (RTC, RTT and Supply Controller). There is no constraint on the length of the reset pulse and the reset controller can guarantee a minimum pulse length. The NRST pin integrates a permanent pull-up resistor to VDDIO of about 100 k Ω . By default, the NRST pin is configured as an input.

6.5 ERASE Pin

The ERASE pin is used to reinitialize the Flash content (and some of its NVM bits) to an erased state (all bits read as logic level 1). It integrates a pull-down resistor of about 100 k Ω to GND, so that it can be left unconnected for normal operations.

This pin is debounced by SCLK to improve the glitch tolerance. When the ERASE pin is tied high during less than 100 ms, it is not taken into account. The pin must be tied high during more than 220 ms to perform a Flash erase operation.

The ERASE pin is a system I/O pin and can be used as a standard I/O. At startup, the ERASE pin is not configured as a PIO pin. If the ERASE pin is used as a standard I/O, startup level of this pin must be low to prevent unwanted erasing. Refer to [Section 10.2 “Peripheral Signal Multiplexing on I/O Lines” on page 40](#). Also, if the ERASE pin is used as a standard I/O output, asserting the pin to low does not erase the Flash.

7. Product Mapping

Figure 7-1. SAM4S Product Mapping

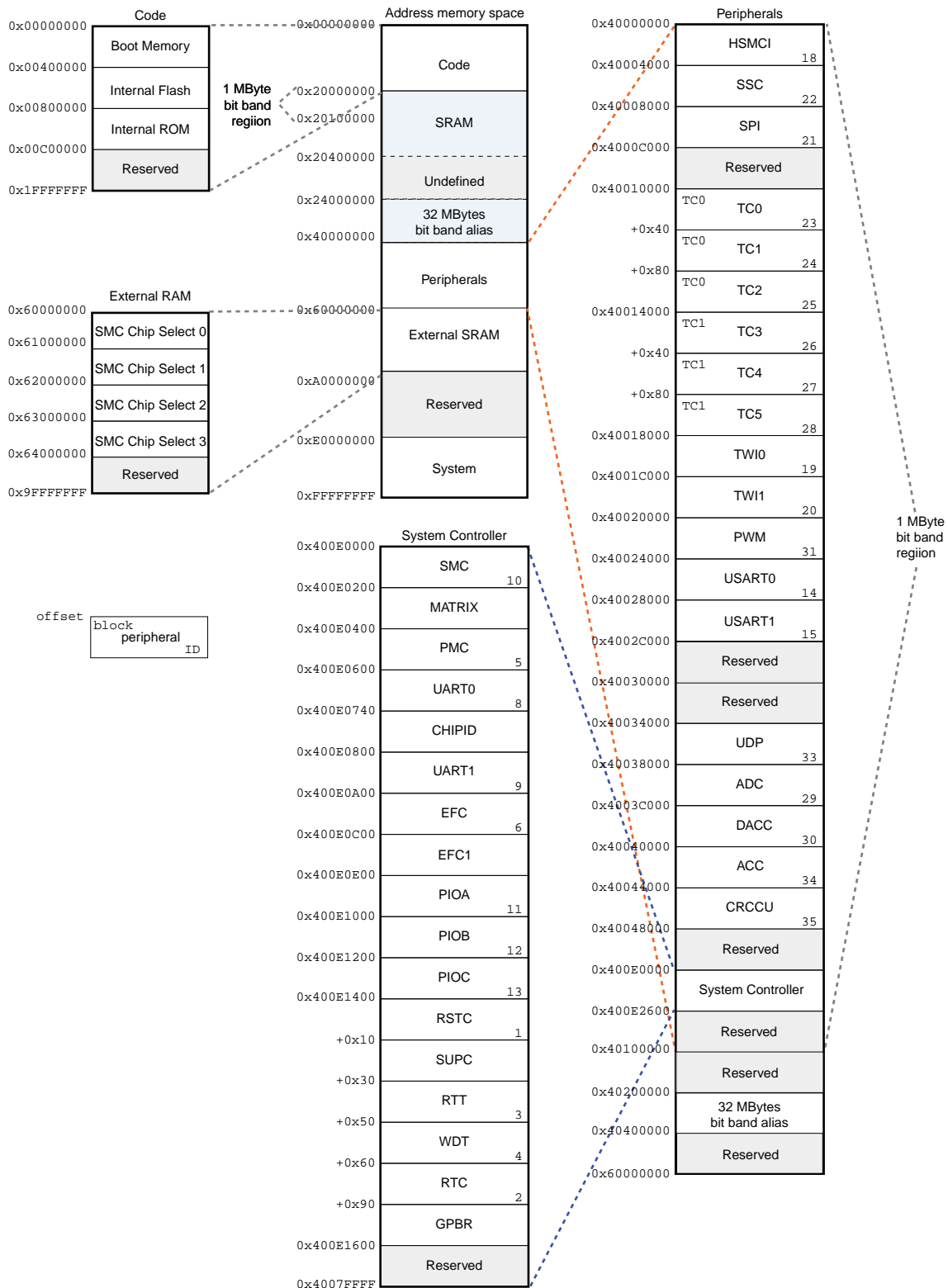

8. Memories

8.1 Embedded Memories

8.1.1 Internal SRAM

The SAM4SD32 device (2x1024 Kbytes) embeds a total of 160-Kbytes high-speed SRAM.

The SAM4SD16 device (2x512KBytes)embeds a total of 160-Kbytes high-speed SRAM.

The SAM4SA16 device (1024 Kbytes) embeds a total of 160-Kbytes high-speed SRAM.

The SAM4S16 device (1024 Kbytes) embeds a total of 128-Kbytes high-speed SRAM.

The SAM4S8 device (512 Kbytes) embeds a total of 128-Kbytes high-speed SRAM.

The SRAM is accessible over System Cortex-M4 bus at address 0x2000 0000.

The SRAM is in the bit band region. The bit band alias region is from 0x2200 0000 to 0x23FF FFFF.

8.1.2 Internal ROM

The SAM4S embeds an Internal ROM, which contains the SAM Boot Assistant (SAM-BA[®]), In Application Programming routines (IAP) and Fast Flash Programming Interface (FFPI).

At any time, the ROM is mapped at address 0x0080 0000.

8.1.3 Embedded Flash

8.1.3.1 Flash Overview

The memory is organized in sectors. Each sector has a size of 64 KBytes. The first sector of 64 KBytes is divided into 3 smaller sectors.

The three smaller sectors are organized to consist of 2 sectors of 8 KBytes and 1 sector of 48 KBytes. Refer to [Figure 8-1, "Global Flash Organization"](#) below.

Figure 8-1. Global Flash Organization

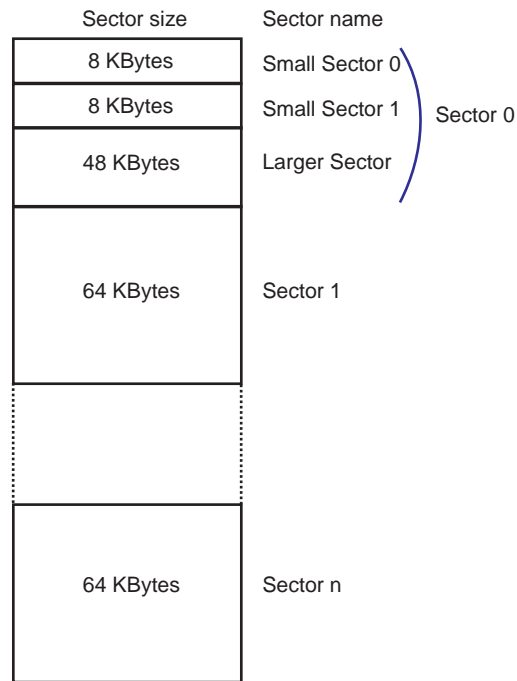

Each Sector is organized in pages of 512 Bytes.

For sector 0:

- The smaller sector 0 has 16 pages of 512Bytes
- The smaller sector 1 has 16 pages of 512 Bytes
- The larger sector has 96 pages of 512 Bytes

From Sector 1 to n:

The rest of the array is composed of 64-KByte sectors of 128 pages, each page of 512 bytes. Refer to [Figure 8-2, "Flash Sector Organization"](#) below.

Figure 8-2. Flash Sector Organization

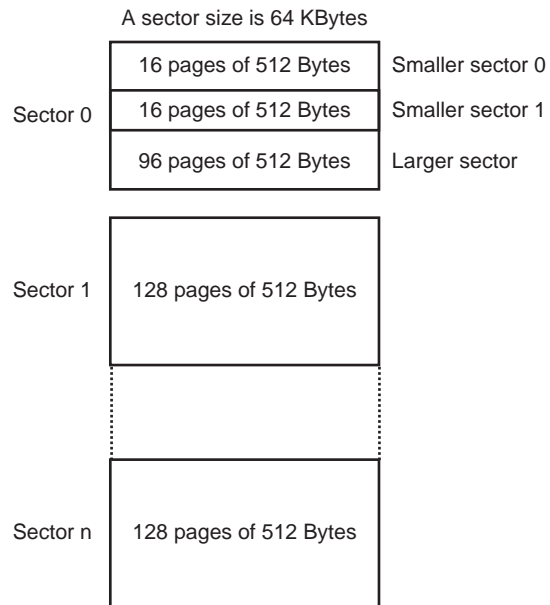

Flash size varies by product:

- SAM4S8/S16: the Flash size is 512 KBytes
 - Internal Flash address is 0x0040_0000
- SAM4SD16/SA16: the Flash size is 2 x 512 KBytes
 - Internal Flash0 address is 0x0040_0000
 - Internal Flash1 address is 0x0048_0000
- SAM4SD32: the Flash size is 2 x 1024 KBytes
 - Internal Flash0 address is 0x0040_0000
 - Internal Flash1 address is 0x0050_0000

Refer to [Figure 8-3, "Flash Size"](#) below for the organization of the Flash following its size.

Figure 8-3. Flash Size

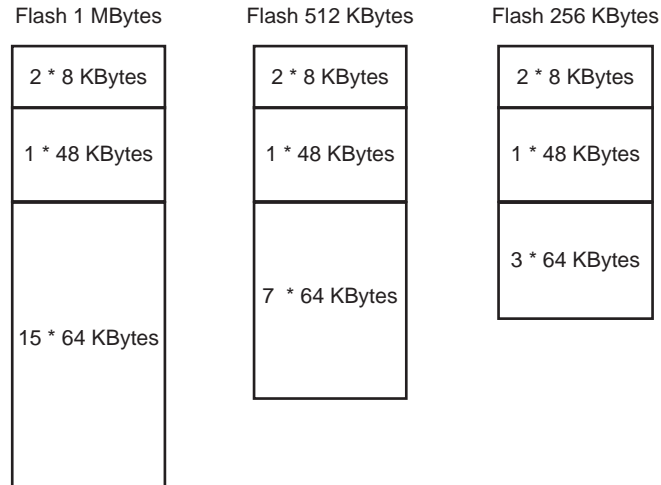

Erasing the memory can be performed as follows:

- On a 512-byte page inside a sector, of 8K Bytes

Note: EWP and EWPL commands can be only used in 8 KBytes sectors.

- On a 4-Kbyte Block inside a sector of 8 KBytes/48 Kbytes/64 KBytes
- On a sector of 8 KBytes/48 KBytes/64 KBytes
- On chip

8.1.3.2 *Enhanced Embedded Flash Controller*

The Enhanced Embedded Flash Controller manages accesses performed by the masters of the system. It enables reading the Flash and writing the write buffer. It also contains a User Interface, mapped on the APB.

The Enhanced Embedded Flash Controller ensures the interface of the Flash block.

It manages the programming, erasing, locking and unlocking sequences of the Flash using a full set of commands.

One of the commands returns the embedded Flash descriptor definition that informs the system about the Flash organization, thus making the software generic.

8.1.3.3 *Flash Speed*

The user needs to set the number of wait states depending on the frequency used:

For more details, refer to the "AC Characteristics" sub-section of the product "Electrical Characteristics".

8.1.3.4 Lock Regions

Several lock bits are used to protect write and erase operations on lock regions. A lock region is composed of several consecutive pages, and each lock region has its associated lock bit.

Table 8-1. Lock Bit Number

Product	Number of Lock Bits	Lock Region Size
SAM4SD32	256 (128 + 128)	8 Kbytes
SAM4SD16	128 (64 + 64)	8 Kbytes
SAM4S16/SA16	128	8 Kbytes
SAM4S8	64	8 Kbytes

If a locked-region's erase or program command occurs, the command is aborted and the EEFC triggers an interrupt.

The lock bits are software programmable through the EEFC User Interface. The command "Set Lock Bit" enables the protection. The command "Clear Lock Bit" unlocks the lock region.

Asserting the ERASE pin clears the lock bits, thus unlocking the entire Flash.

8.1.3.5 Security Bit Feature

The SAM4SD32 and SAM4SD16 feature 2 security bits, the SAM4S16/SA16/S8 feature a security bit, based on a specific General Purpose NVM bit (GPNVM bit 0). When one of the security bits is enabled, any access to the Flash, SRAM, Core Registers and Internal Peripherals either through the ICE interface or through the Fast Flash Programming Interface, is forbidden. This ensures the confidentiality of the code programmed in the Flash.

This security bit can only be enabled, through the command "Set General Purpose NVM Bit 0" of the EEFC User Interface. Disabling the security bit can only be achieved by asserting the ERASE pin at 1, and after a full Flash erase is performed. When the security bit is deactivated, all accesses to the Flash, SRAM, Core registers, Internal Peripherals are permitted.

It is important to note that the assertion of the ERASE pin should always be longer than 200 ms.

As the ERASE pin integrates a permanent pull-down, it can be left unconnected during normal operation. However, it is safer to connect it directly to GND for the final application.

8.1.3.6 Calibration Bits

NVM bits are used to calibrate the brownout detector and the voltage regulator. These bits are factory configured and cannot be changed by the user. The ERASE pin has no effect on the calibration bits.

8.1.3.7 Unique Identifier

Each device integrates its own 128-bit unique identifier. These bits are factory configured and cannot be changed by the user. The ERASE pin has no effect on the unique identifier.

8.1.3.8 User Signature

Each part contains a User Signature of 512 bytes. It can be used by the user to store user information such as trimming, keys, etc., that the customer does not want to be erased by asserting the ERASE pin or by software ERASE command. Read, write and erase of this area is allowed.

8.1.3.9 Fast Flash Programming Interface

The Fast Flash Programming Interface allows programming the device through a multiplexed fully-handshaked parallel port. It allows gang programming with market-standard industrial programmers.

The FFPI supports read, page program, page erase, full erase, lock, unlock and protect commands.

8.1.3.10 SAM-BA Boot

The SAM-BA Boot is a default Boot Program which provides an easy way to program in-situ the on-chip Flash memory.

The SAM-BA Boot Assistant supports serial communication via the UART and USB.

The SAM-BA Boot provides an interface with SAM-BA Graphic User Interface (GUI).

The SAM-BA Boot is in ROM and is mapped in Flash at address 0x0 when GPNVM bit 1 is set to 0.

8.1.3.11 GPNVM Bits

The SAM4S16 features two GPNVM bits. These bits can be cleared or set respectively through the commands "Clear GPNVM Bit" and "Set GPNVM Bit" of the EEFC User Interface.

The Flash of the SAM4S8 is composed of 512 Kbytes in a single bank.

The SAM4SA16/SD32/SD16 features 3 GPNVM bits (GPNVM from Flash0) that can be cleared or set respectively through the "Clear GPNVM Bit" and "Set GPNVM Bit" commands of the EEFC0 User Interface. The GPNVM bits of the SAM4SA16/SD16/SD32 are only available on FLash0. There is no GPNVM bit on Flash1. The GPNVM0 is the security bit. The GPNVM1 is used to select the boot mode (boot always at 0x00) on ROM or FLASH. The SAM4SD32/16 embeds an additional GPNVM bit: GPNVM2. This GPNVM bit is used only to swap the Flash0 and Flash1. If GPNVM bit 2 is:

ENABLE: the Flash1 is mapped at address 0x0040_0000 (Flash1 and Flash0 are continuous).

DISABLE: the Flash0 is mapped at address 0x0040_0000 (Flash0 and Flash1 are continuous).

Table 8-2. General-purpose Non volatile Memory Bits

GPNVMBit[#]	Function
0	Security bit
1	Boot mode selection
2	Flash selection (Flash 0 or Flash 1)

8.1.4 Boot Strategies

The system always boots at address 0x0. To ensure maximum boot possibilities, the memory layout can be changed via GPNVM.

A general purpose NVM (GPNVM) bit is used to boot either on the ROM (default) or from the Flash.

The GPNVM bit can be cleared or set respectively through the commands "Clear General-purpose NVM Bit" and "Set General-purpose NVM Bit" of the EEFC User Interface.

Setting GPNVM Bit 1 selects the boot from the Flash, clearing it selects the boot from the ROM. Asserting ERASE clears the GPNVM Bit 1 and thus selects the boot from the ROM by default.

Setting the GPNVM Bit 2 selects bank 1, clearing it selects the boot from bank 0. Asserting ERASE clears the GPNVM Bit 2 and thus selects the boot from bank 0 by default.

8.2 External Memories

The SAM4S features one External Bus Interface to provide an interface to a wide range of external memories and to any parallel peripheral.

8.2.1 Static Memory Controller

- 16-Mbyte Address Space per Chip Select
- 8-bit Data Bus
- Word, Halfword, Byte Transfers
- Programmable Setup, Pulse And Hold Time for Read Signals per Chip Select
- Programmable Setup, Pulse And Hold Time for Write Signals per Chip Select
- Programmable Data Float Time per Chip Select
- External Wait Request
- Automatic Switch to Slow Clock Mode
- Asynchronous Read in Page Mode Supported: Page Size Ranges from 4 to 32 Bytes
- NAND Flash additional logic supporting NAND Flash with Multiplexed Data/Address buses
- Hardware Configurable number of chip selects from 1 to 4
- Programmable timing on a per chip select basis

9. System Controller

The System Controller is a set of peripherals which allows handling of key elements of the system, such as power, resets, clocks, time, interrupts, watchdog, etc...

See the system controller block diagram in [Figure 9-1 on page 37](#).

Figure 9-1. System Controller Block Diagram

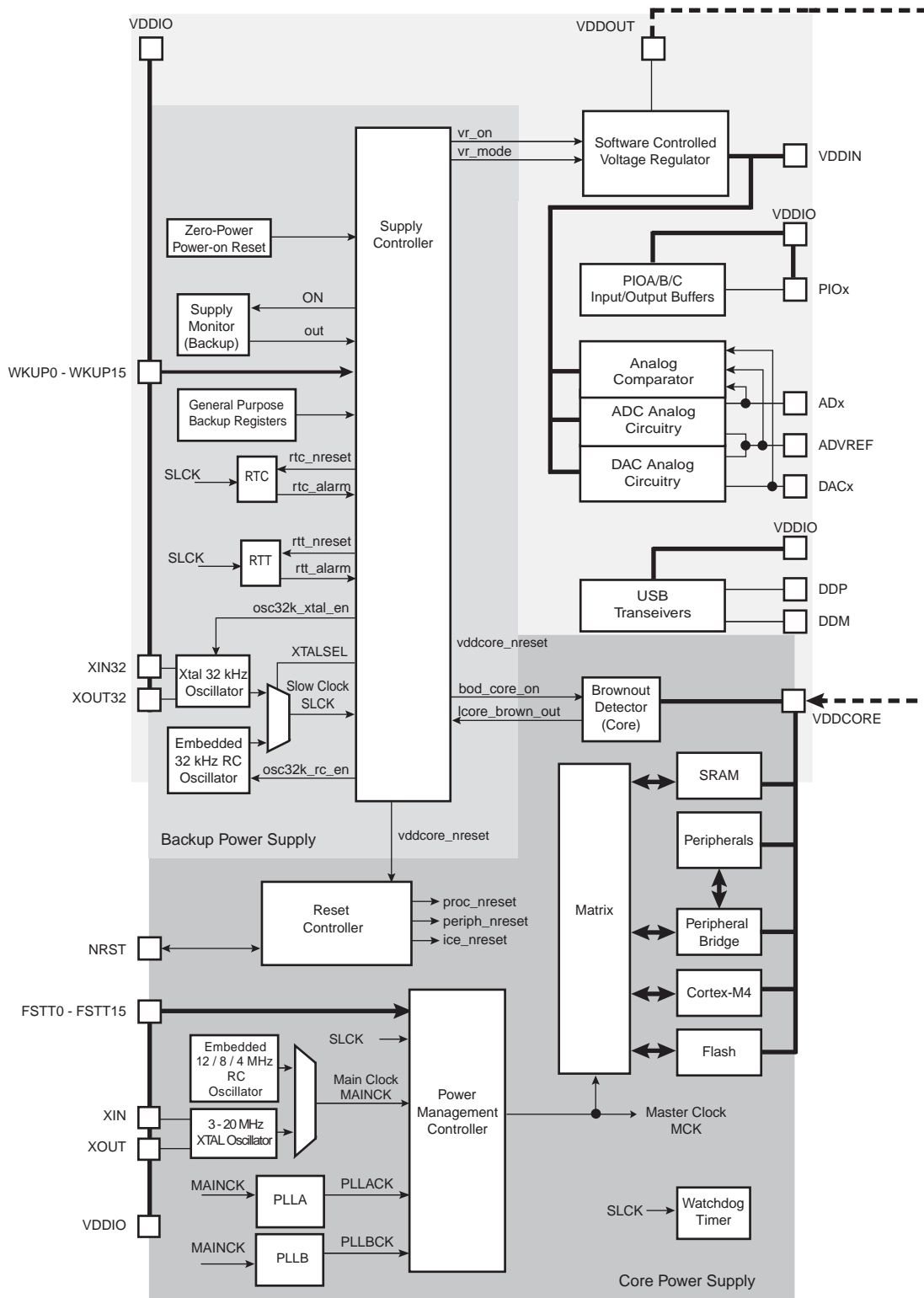

FSTT0 - FSTT15 are possible Fast Startup sources, generated by WKUP0 - WKUP15 pins, but are not physical pins.

9.1 System Controller and Peripheral Mapping

Refer to [Figure 7-1, "SAM4S Product Mapping"](#).

All the peripherals are in the bit band region and are mapped in the bit band alias region.

9.2 Power-on-Reset, Brownout and Supply Monitor

The SAM4S embeds three features to monitor, warn and/or reset the chip:

- Power-on-Reset on VDDIO
- Brownout Detector on VDDCORE
- Supply Monitor on VDDIO

9.2.1 Power-on-Reset

The Power-on-Reset monitors VDDIO. It is always activated and monitors voltage at start up but also during power down. If VDDIO goes below the threshold voltage, the entire chip is reset. For more information, refer to the Electrical Characteristics section of the datasheet.

9.2.2 Brownout Detector on VDDCORE

The Brownout Detector monitors VDDCORE. It is active by default. It can be deactivated by software through the Supply Controller (SUPC_MR). It is especially recommended to disable it during low-power modes such as wait or sleep modes.

If VDDCORE goes below the threshold voltage, the reset of the core is asserted. For more information, refer to the Supply Controller (SUPC) and Electrical Characteristics sections of the datasheet.

9.2.3 Supply Monitor on VDDIO

The Supply Monitor monitors VDDIO. It is not active by default. It can be activated by software and is fully programmable with 16 steps for the threshold (between 1.6V to 3.4V). It is controlled by the Supply Controller (SUPC). A sample mode is possible. It allows to divide the supply monitor power consumption by a factor of up to 2048. For more information, refer to the SUPC and Electrical Characteristics sections of the datasheet.

10. Peripherals

10.1 Peripheral Identifiers

Table 10-1 defines the Peripheral Identifiers of the SAM4S. A peripheral identifier is required for the control of the peripheral interrupt with the Nested Vectored Interrupt Controller and control of the peripheral clock with the Power Management Controller.

Table 10-1. Peripheral Identifiers

Instance ID	Instance Name	NVIC Interrupt	PMC Clock Control	Instance Description
0	SUPC	X		Supply Controller
1	RSTC	X		Reset Controller
2	RTC	X		Real Time Clock
3	RTT	X		Real Time Timer
4	WDT	X		Watchdog Timer
5	PMC	X		Power Management Controller
6	EEFC0	X		Enhanced Embedded Flash Controller 0
7	EEFC1	-		Enhanced Embedded Flash Controller 1
8	UART0	X	X	UART 0
9	UART1	X	X	UART 1
10	SMC	X	X	Static Memory Controller
11	PIOA	X	X	Parallel I/O Controller A
12	PIOB	X	X	Parallel I/O Controller B
13	PIOC	X	X	Parallel I/O Controller C
14	USART0	X	X	USART 0
15	USART1	X	X	USART 1
16	-	-	-	Reserved
17	-	-	-	Reserved
18	HSMCI	X	X	Multimedia Card Interface
19	TWI0	X	X	Two Wire Interface 0
20	TWI1	X	X	Two Wire Interface 1
21	SPI	X	X	Serial Peripheral Interface
22	SSC	X	X	Synchronous Serial Controller
23	TC0	X	X	Timer/Counter 0
24	TC1	X	X	Timer/Counter 1
25	TC2	X	X	Timer/Counter 2
26	TC3	X	X	Timer/Counter 3
27	TC4	X	X	Timer/Counter 4
28	TC5	X	X	Timer/Counter 5
29	ADC	X	X	Analog To Digital Converter
30	DACC	X	X	Digital To Analog Converter

Table 10-1. Peripheral Identifiers (Continued)

Instance ID	Instance Name	NVIC Interrupt	PMC Clock Control	Instance Description
31	PWM	X	X	Pulse Width Modulation
32	CRCCU	X	X	CRC Calculation Unit
33	ACC	X	X	Analog Comparator
34	UDP	X	X	USB Device Port

10.2 Peripheral Signal Multiplexing on I/O Lines

The SAM4S features 2 PIO controllers on 64-pin versions (PIOA and PIOB) or 3 PIO controllers on the 100-pin version (PIOA, PIOB and PIOC), that multiplex the I/O lines of the peripheral set.

The SAM4S 64-pin and 100-pin PIO Controllers control up to 32 lines. Each line can be assigned to one of three peripheral functions: A, B or C. The multiplexing tables in the following paragraphs define how the I/O lines of the peripherals A, B and C are multiplexed on the PIO Controllers. The column “Comments” has been inserted in this table for the user’s own comments; it may be used to track how pins are defined in an application.

Note that some peripheral functions which are output only, might be duplicated within the tables.

10.2.1 PIO Controller A Multiplexing

Table 10-2. Multiplexing on PIO Controller A (PIOA)

I/O Line	Peripheral A	Peripheral B	Peripheral C	Extra Function	System Function	Comments
PA0	PWMH0	TIOA0	A17	WKUP0		
PA1	PWMH1	TIOB0	A18	WKUP1		
PA2	PWMH2	SCK0	DATRG	WKUP2		
PA3	TWD0	NPCS3				
PA4	TWCK0	TCLK0		WKUP3		
PA5	RXD0	NPCS3		WKUP4		
PA6	TXD0	PCK0				
PA7	RTS0	PWMH3			XIN32	
PA8	CTS0	ADTRG		WKUP5	XOUT32	
PA9	URXD0	NPCS1	PWMF10	WKUP6		
PA10	UTXD0	NPCS2				
PA11	NPCS0	PWMH0		WKUP7		
PA12	MISO	PWMH1				
PA13	MOSI	PWMH2				
PA14	SPCK	PWMH3		WKUP8		
PA15	TF	TIOA1	PWML3	WKUP14/PIODCEN1		
PA16	TK	TIOB1	PWML2	WKUP15/PIODCEN2		
PA17	TD	PCK1	PWMH3	AD0		
PA18	RD	PCK2	A14	AD1		
PA19	RK	PWML0	A15	AD2/WKUP9		
PA20	RF	PWML1	A16	AD3/WKUP10		
PA21	RXD1	PCK1		AD8		64/100 pins versions
PA22	TXD1	NPCS3	NCS2	AD9		64/100 pins versions
PA23	SCK1	PWMH0	A19	PIODCCLK		64/100 pins versions
PA24	RTS1	PWMH1	A20	PIODC0		64/100 pins versions
PA25	CTS1	PWMH2	A23	PIODC1		64/100 pins versions
PA26	DCD1	TIOA2	MCDA2	PIODC2		64/100 pins versions
PA27	DTR1	TIOB2	MCDA3	PIODC3		64/100 pins versions
PA28	DSR1	TCLK1	MCCDA	PIODC4		64/100 pins versions
PA29	RI1	TCLK2	MCCK	PIODC5		64/100 pins versions
PA30	PWML2	NPCS2	MCDA0	WKUP11/PIODC6		64/100 pins versions
PA31	NPCS1	PCK2	MCDA1	PIODC7		64/100 pins versions

10.2.2 PIO Controller B Multiplexing

Table 10-3. Multiplexing on PIO Controller B (PIOB)

I/O Line	Peripheral A	Peripheral B	Peripheral C	Extra Function	System Function	Comments
PB0	PWMH0			AD4/RTCOUT0		
PB1	PWMH1			AD5/RTCOUT1		
PB2	URXD1	NPCS2		AD6/WKUP12		
PB3	UTXD1	PCK2		AD7		
PB4	TWD1	PWMH2			TDI	
PB5	TWCK1	PWML0		WKUP13	TDO/TRACESWO	
PB6					TMS/SWDIO	
PB7					TCK/SWCLK	
PB8					XOUT	
PB9					XIN	
PB10					DDM	
PB11					DDP	
PB12	PWML1				ERASE	
PB13	PWML2	PCK0		DAC0		64/100 pins versions
PB14	NPCS1	PWMH3		DAC1		64/100 pins versions

10.2.3 PIO Controller C Multiplexing

Table 10-4. Multiplexing on PIO Controller C (PIOC)

I/O Line	Peripheral A	Peripheral B	Peripheral C	Extra Function	System Function	Comments
PC0	D0	PWML0				100 pin version
PC1	D1	PWML1				100 pin version
PC2	D2	PWML2				100 pin version
PC3	D3	PWML3				100 pin version
PC4	D4	NPCS1				100 pin version
PC5	D5					100 pin version
PC6	D6					100 pin version
PC7	D7					100 pin version
PC8	NWE					100 pin version
PC9	NANDOE					100 pin version
PC10	NANDWE					100 pin version
PC11	NRD					100 pin version
PC12	NCS3			AD12		100 pin version
PC13	NWAIT	PWML0		AD10		100 pin version
PC14	NCS0					100 pin version
PC15	NCS1	PWML1		AD11		100 pin version
PC16	A21/NANDALE					100 pin version
PC17	A22/NANDCLE					100 pin version
PC18	A0	PWMH0				100 pin version
PC19	A1	PWMH1				100 pin version
PC20	A2	PWMH2				100 pin version
PC21	A3	PWMH3				100 pin version
PC22	A4	PWML3				100 pin version
PC23	A5	TIOA3				100 pin version
PC24	A6	TIOB3				100 pin version
PC25	A7	TCLK3				100 pin version
PC26	A8	TIOA4				100 pin version
PC27	A9	TIOB4				100 pin version
PC28	A10	TCLK4				100 pin version
PC29	A11	TIOA5		AD13		100 pin version
PC30	A12	TIOB5		AD14		100 pin version
PC31	A13	TCLK5				100 pin version



11. ARM Cortex-M4

11.1 Description

The Cortex-M4 processor is a high performance 32-bit processor designed for the microcontroller market. It offers significant benefits to developers, including outstanding processing performance combined with fast interrupt handling, enhanced system debug with extensive breakpoint and trace capabilities, efficient processor core, system and memories, ultra-low power consumption with integrated sleep modes, and platform security robustness, with integrated memory protection unit (MPU).

The Cortex-M4 processor is built on a high-performance processor core, with a 3-stage pipeline Harvard architecture, making it ideal for demanding embedded applications. The processor delivers exceptional power efficiency through an efficient instruction set and extensively optimized design, providing high-end processing hardware including a range of single-cycle and SIMD multiplication and multiply-with-accumulate capabilities, saturating arithmetic and dedicated hardware division.

To facilitate the design of cost-sensitive devices, the Cortex-M4 processor implements tightly-coupled system components that reduce processor area while significantly improving interrupt handling and system debug capabilities. The Cortex-M4 processor implements a version of the Thumb® instruction set based on Thumb-2 technology, ensuring high code density and reduced program memory requirements. The Cortex-M4 instruction set provides the exceptional performance expected of a modern 32-bit architecture, with the high code density of 8-bit and 16-bit microcontrollers.

The Cortex-M4 processor closely integrates a configurable NVIC, to deliver industry-leading interrupt performance. The NVIC includes a non-maskable interrupt (NMI), and provides up to 256 interrupt priority levels. The tight integration of the processor core and NVIC provides fast execution of interrupt service routines (ISRs), dramatically reducing the interrupt latency. This is achieved through the hardware stacking of registers, and the ability to suspend load-multiple and store-multiple operations. Interrupt handlers do not require wrapping in assembler code, removing any code overhead from the ISRs. A tail-chain optimization also significantly reduces the overhead when switching from one ISR to another.

To optimize low-power designs, the NVIC integrates with the sleep modes, that include a deep sleep function that enables the entire device to be rapidly powered down while still retaining program state.

11.1.1 System Level Interface

The Cortex-M4 processor provides multiple interfaces using AMBA® technology to provide high speed, low latency memory accesses. It supports unaligned data accesses and implements atomic bit manipulation that enables faster peripheral controls, system spinlocks and thread-safe Boolean data handling.

The Cortex-M4 processor has a Memory Protection Unit (MPU) that provides fine grain memory control, enabling applications to utilize multiple privilege levels, separating and protecting code, data and stack on a task-by-task basis. Such requirements are becoming critical in many embedded applications such as automotive.

11.1.2 Integrated Configurable Debug

The Cortex-M4 processor implements a complete hardware debug solution. This provides high system visibility of the processor and memory through either a traditional JTAG port or a 2-pin Serial Wire Debug (SWD) port that is ideal for microcontrollers and other small package devices.

For system trace the processor integrates an Instrumentation Trace Macrocell (ITM) alongside data watchpoints and a profiling unit. To enable simple and cost-effective profiling of the system events these generate, a Serial Wire Viewer (SWV) can export a stream of software-generated messages, data trace, and profiling information through a single pin.

The Flash Patch and Breakpoint Unit (FPB) provides up to 8 hardware breakpoint comparators that debuggers can use. The comparators in the FPB also provide remap functions of up to 8 words in the program code in the CODE memory region. This enables applications stored on a non-erasable, ROM-based microcontroller to be patched if a small programmable memory, for example flash, is available in the device. During initialization, the application in ROM detects, from the programmable memory, whether a patch is required. If a patch is required, the application programs the FPB to remap a number of addresses. When those addresses are accessed, the accesses are redirected to a remap table specified in the FPB configuration, which means the program in the non-modifiable ROM can be patched.

11.2 Embedded Characteristics

- Tight integration of system peripherals reduces area and development costs
- Thumb instruction set combines high code density with 32-bit performance
- Code-patch ability for ROM system updates
- Power control optimization of system components
- Integrated sleep modes for low power consumption
- Fast code execution permits slower processor clock or increases sleep mode time
- Hardware division and fast digital-signal-processing oriented multiply accumulate
- Saturating arithmetic for signal processing
- Deterministic, high-performance interrupt handling for time-critical applications
- Memory Protection Unit (MPU) for safety-critical applications
- Extensive debug and trace capabilities:
 - Serial Wire Debug and Serial Wire Trace reduce the number of pins required for debugging, tracing, and code profiling.

11.3 Block Diagram

Figure 11-1. Typical Cortex-M4 Implementation

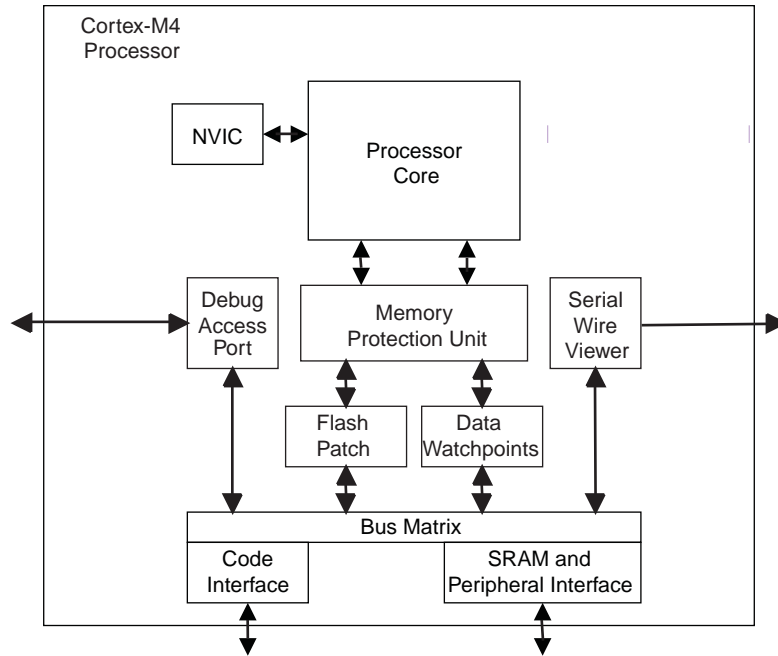

11.4 Cortex-M4 Models

11.4.1 Programmers Model

This section describes the Cortex-M4 programmers model. In addition to the individual core register descriptions, it contains information about the processor modes and privilege levels for software execution and stacks.

11.4.1.1 Processor Modes And Privilege Levels for Software Execution

The processor *modes* are:

- Thread mode
Used to execute application software. The processor enters the Thread mode when it comes out of reset.
- Handler mode
Used to handle exceptions. The processor returns to the Thread mode when it has finished exception processing.

The *privilege levels* for software execution are:

- Unprivileged
The software:
 - has limited access to the MSR and MRS instructions, and cannot use the CPS instruction
 - cannot access the System Timer, NVIC, or System Control Block
 - might have a restricted access to memory or peripherals.

Unprivileged software executes at the unprivileged level.

- Privileged
The software can use all the instructions and has access to all resources. *Privileged software* executes at the privileged level.

In Thread mode, the CONTROL register controls whether the software execution is privileged or unprivileged, see “[CONTROL Register](#)” . In Handler mode, software execution is always privileged.

Only privileged software can write to the CONTROL register to change the privilege level for software execution in Thread mode. Unprivileged software can use the SVC instruction to make a *supervisor call* to transfer control to privileged software.

11.4.1.2 Stacks

The processor uses a full descending stack. This means the stack pointer holds the address of the last stacked item in memory. When the processor pushes a new item onto the stack, it decrements the stack pointer and then writes the item to the new memory location. The processor implements two stacks, the *main stack* and the *process stack*, with a pointer for each held in independent registers, see “[Stack Pointer](#)” .

In Thread mode, the CONTROL register controls whether the processor uses the main stack or the process stack, see “[CONTROL Register](#)” .

In Handler mode, the processor always uses the main stack.

The options for processor operations are:

Table 11-1. Summary of processor mode, execution privilege level, and stack use options

Processor Mode	Used to Execute	Privilege Level for Software Execution	Stack Used
Thread	Applications	Privileged or unprivileged ⁽¹⁾	Main stack or process stack ⁽¹⁾
Handler	Exception handlers	Always privileged	Main stack

Note: 1. See “CONTROL Register” .

11.4.1.3 Core Registers

Figure 11-2. Processor Core Registers

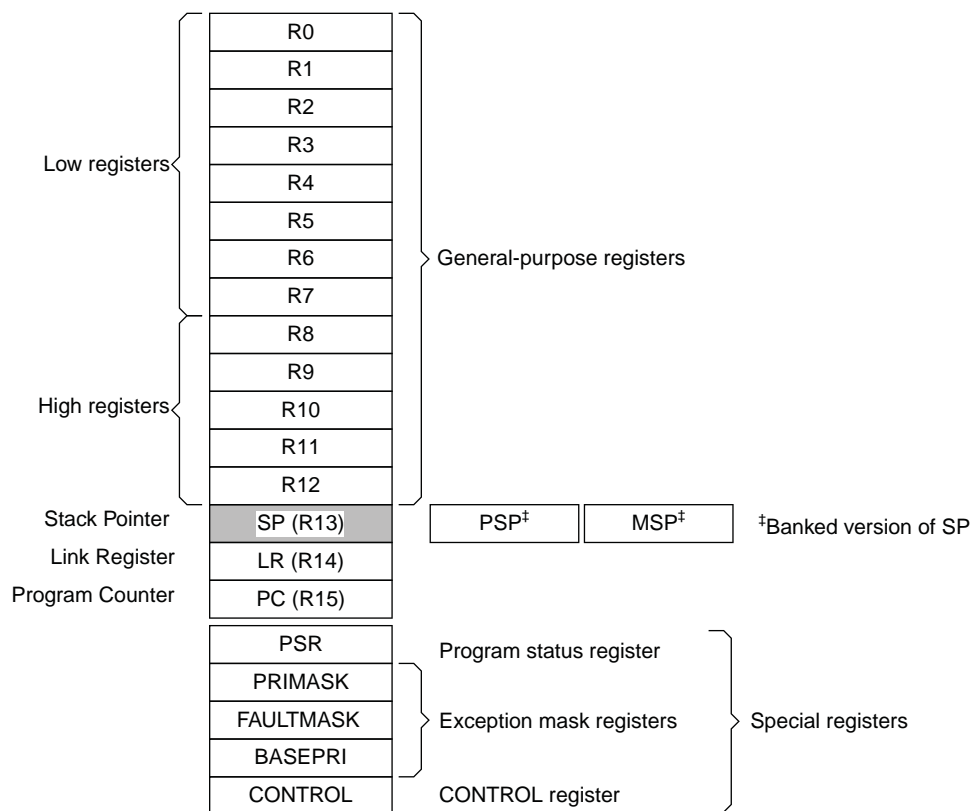

Table 11-2. Core Processor Registers

Register	Name	Access ⁽¹⁾	Required Privilege ⁽²⁾	Reset
General-purpose registers	R0-R12	Read-write	Either	Unknown
Stack Pointer	MSP	Read-write	Privileged	See description
Stack Pointer	PSP	Read-write	Either	Unknown

Table 11-2. Core Processor Registers

Register	Name	Access ⁽¹⁾	Required Privilege ⁽²⁾	Reset
Link Register	LR	Read-write	Either	0xFFFFFFFF
Program Counter	PC	Read-write	Either	See description
Program Status Register	PSR	Read-write	Privileged	0x01000000
Application Program Status Register	APSR	Read-write	Either	0x00000000
Interrupt Program Status Register	IPSR	Read-only	Privileged	0x00000000
Execution Program Status Register	EPSR	Read-only	Privileged	0x01000000
Priority Mask Register	PRIMASK	Read-write	Privileged	0x00000000
Fault Mask Register	FAULTMASK	Read-write	Privileged	0x00000000
Base Priority Mask Register	BASEPRI	Read-write	Privileged	0x00000000
CONTROL register	CONTROL	Read-write	Privileged	0x00000000

Notes: 1. Describes access type during program execution in thread mode and Handler mode. Debug access can differ.
 2. An entry of Either means privileged and unprivileged software can access the register.

11.4.1.4 General-purpose Registers

R0-R12 are 32-bit general-purpose registers for data operations.

11.4.1.5 Stack Pointer

The *Stack Pointer* (SP) is register R13. In Thread mode, bit[1] of the CONTROL register indicates the stack pointer to use:

- 0 = *Main Stack Pointer* (MSP). This is the reset value.
- 1 = *Process Stack Pointer* (PSP).

On reset, the processor loads the MSP with the value from address 0x00000000.

11.4.1.6 Link Register

The *Link Register* (LR) is register R14. It stores the return information for subroutines, function calls, and exceptions. On reset, the processor loads the LR value 0xFFFFFFFF.

11.4.1.7 Program Counter

The *Program Counter* (PC) is register R15. It contains the current program address. On reset, the processor loads the PC with the value of the reset vector, which is at address 0x00000004. Bit[0] of the value is loaded into the EPSR T-bit at reset and must be 1.

11.4.1.8 Program Status Register

Name: PSR
Access: Read-write
Reset: 0x00000000

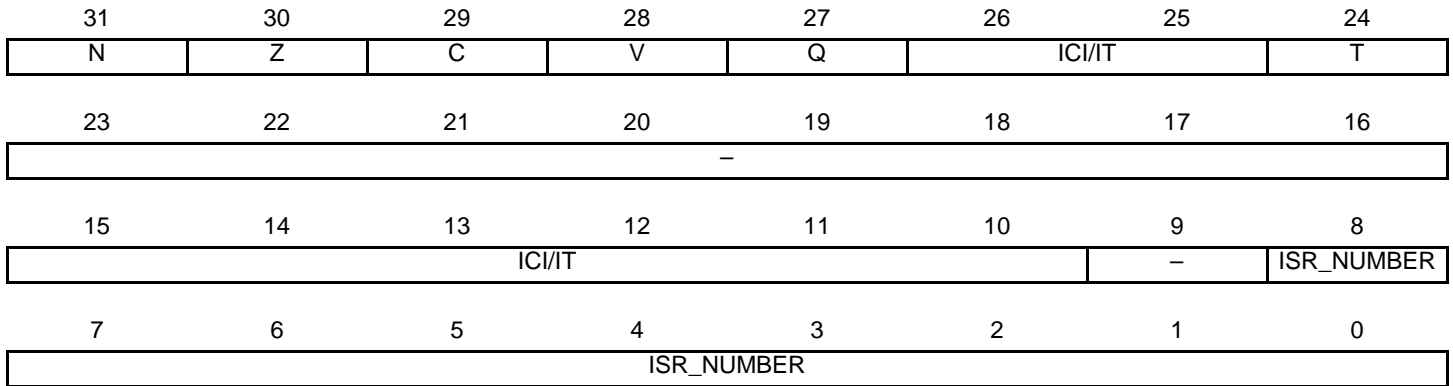

The *Program Status Register* (PSR) combines:

- *Application Program Status Register* (APSR)
- *Interrupt Program Status Register* (IPSR)
- *Execution Program Status Register* (EPSR).

These registers are mutually exclusive bitfields in the 32-bit PSR.

Access these registers individually or as a combination of any two or all three registers, using the register name as an argument to the MSR or MRS instructions. For example:

- read all of the registers using PSR with the MRS instruction
- write to the APSR N, Z, C, V and Q bits using APSR_nzcvq with the MSR instruction.

The PSR combinations and attributes are:

Name	Access	Combination
PSR	Read-write ⁽¹⁾⁽²⁾	APSR, EPSR, and IPSR
IEPSR	Read-only	EPSR and IPSR
IAPSR	Read-write ⁽¹⁾	APSR and IPSR
EAPSR	Read-write ⁽²⁾	APSR and EPSR

- Notes:
1. The processor ignores writes to the IPSR bits.
 2. Reads of the EPSR bits return zero, and the processor ignores writes to these bits.

See the instruction descriptions “MRS” and “MSR” for more information about how to access the program status registers.

11.4.1.9 Application Program Status Register

Name: APSR
Access: Read-write
Reset: 0x00000000

31	30	29	28	27	26	25	24
N	Z	C	V	Q	-		
23	22	21	20	19	18	17	16
-				GE[3:0]			
15	14	13	12	11	10	9	8
-							
7	6	5	4	3	2	1	0
-							

The APSR contains the current state of the condition flags from previous instruction executions.

- **N: Negative Flag**

0: operation result was positive, zero, greater than, or equal
 1: operation result was negative or less than.

- **Z: Zero Flag**

0: operation result was not zero
 1: operation result was zero.

- **C: Carry or Borrow Flag**

Carry or borrow flag:
 0: add operation did not result in a carry bit or subtract operation resulted in a borrow bit
 1: add operation resulted in a carry bit or subtract operation did not result in a borrow bit.

- **V: Overflow Flag**

0: operation did not result in an overflow
 1: operation resulted in an overflow.

- **Q: DSP Overflow and Saturation Flag**

Sticky saturation flag:
 0: indicates that saturation has not occurred since reset or since the bit was last cleared to zero
 1: indicates when an `SSAT` or `USAT` instruction results in saturation.
 This bit is cleared to zero by software using an `MRS` instruction.

- **GE[19:16]: Greater Than or Equal Flags**

See “[SEL](#)” for more information.

11.4.1.10 Interrupt Program Status Register

Name: IPSR

Access: Read-write

Reset: 0x00000000

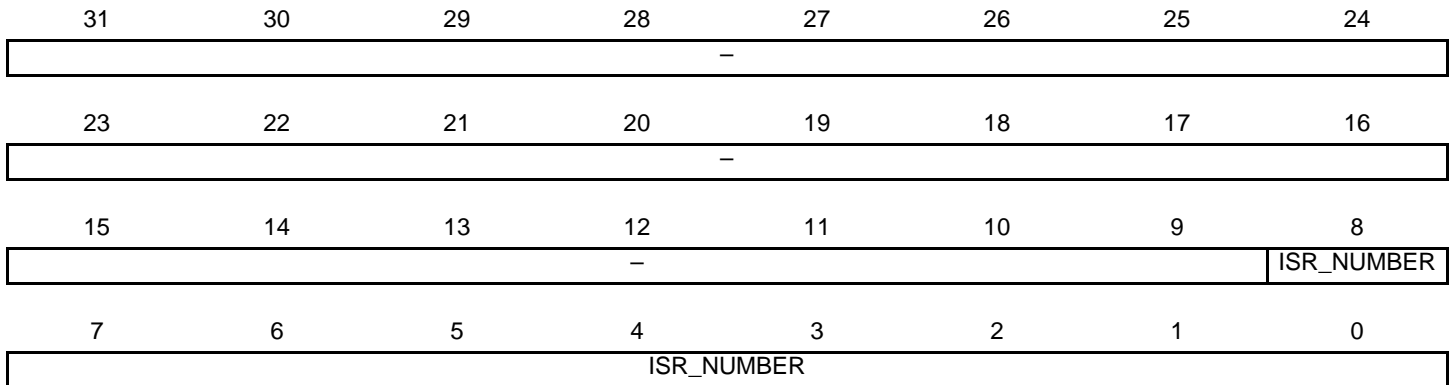

The IPSR contains the exception type number of the current *Interrupt Service Routine* (ISR).

- **ISR_NUMBER: Number of the Current Exception**

0 = Thread mode

1 = Reserved

2 = NMI

3 = Hard fault

4 = Memory management fault

5 = Bus fault

6 = Usage fault

7-10 = Reserved

11 = SVCcall

12 = Reserved for Debug

13 = Reserved

14 = PendSV

15 = SysTick

16 = IRQ0

50 = IRQ34

See [“Exception Types”](#) for more information.

11.4.1.11 Execution Program Status Register

Name: EPSR
Access: Read-write
Reset: 0x00000000



The EPSR contains the Thumb state bit, and the execution state bits for either the *If-Then* (IT) instruction, or the *Interruptible-Continuable Instruction* (ICI) field for an interrupted load multiple or store multiple instruction.

Attempts to read the EPSR directly through application software using the MSR instruction always return zero. Attempts to write the EPSR using the MSR instruction in the application software are ignored. Fault handlers can examine the EPSR value in the stacked PSR to indicate the operation that is at fault. See [“Exception Entry and Return”](#)

• **ICI: Interruptible-continuable Instruction**

When an interrupt occurs during the execution of an LDM, STM, PUSH, POP, VLDM, VSTM, VPOP, or VPOP instruction, the processor:

- stops the load multiple or store multiple instruction operation temporarily
- stores the next register operand in the multiple operation to EPSR bits[15:12].

After servicing the interrupt, the processor:

- returns to the register pointed to by bits[15:12]
- resumes the execution of the multiple load or store instruction.

When the EPSR holds the ICI execution state, bits[26:25,11:10] are zero.

• **IT: If-Then Instruction**

Indicates the execution state bits of the IT instruction.

The If-Then block contains up to four instructions following an IT instruction. Each instruction in the block is conditional. The conditions for the instructions are either all the same, or some can be the inverse of others. See [“”](#) for more information.

• **T: Thumb State**

The Cortex-M4 processor only supports the execution of instructions in Thumb state. The following can clear the T bit to 0:

- instructions BLX, BX and POP{PC}
- restoration from the stacked xPSR value on an exception return
- bit[0] of the vector value on an exception entry or reset.

Attempting to execute instructions when the T bit is 0 results in a fault or lockup. See [“Lockup”](#) for more information.

11.4.1.12 Exception Mask Registers

The exception mask registers disable the handling of exceptions by the processor. Disable exceptions where they might impact on timing critical tasks.

To access the exception mask registers use the MSR and MRS instructions, or the CPS instruction to change the value of PRIMASK or FAULTMASK. See “MRS”, “MSR”, and “CPS” for more information.

11.4.1.13 Priority Mask Register

Name: PRIMASK

Access: Read-write

Reset: 0x00000000

31	30	29	28	27	26	25	24
-							
23	22	21	20	19	18	17	16
-							
15	14	13	12	11	10	9	8
-							
7	6	5	4	3	2	1	0
-							PRIMASK

The PRIMASK register prevents the activation of all exceptions with a configurable priority.

- **PRIMASK**

0: no effect

1: prevents the activation of all exceptions with a configurable priority.

11.4.1.14 Fault Mask Register

Name: FAULTMASK

Access: Read-write

Reset: 0x00000000

31	30	29	28	27	26	25	24
-							
23	22	21	20	19	18	17	16
-							
15	14	13	12	11	10	9	8
-							
7	6	5	4	3	2	1	0
-							FAULTMASK

The FAULTMASK register prevents the activation of all exceptions except for Non-Maskable Interrupt (NMI).

- **FAULTMASK**

0: No effect.

1: Prevents the activation of all exceptions except for NMI.

The processor clears the FAULTMASK bit to 0 on exit from any exception handler except the NMI handler.

11.4.1.15 Base Priority Mask Register

Name: BASEPRI

Access: Read-write

Reset: 0x00000000

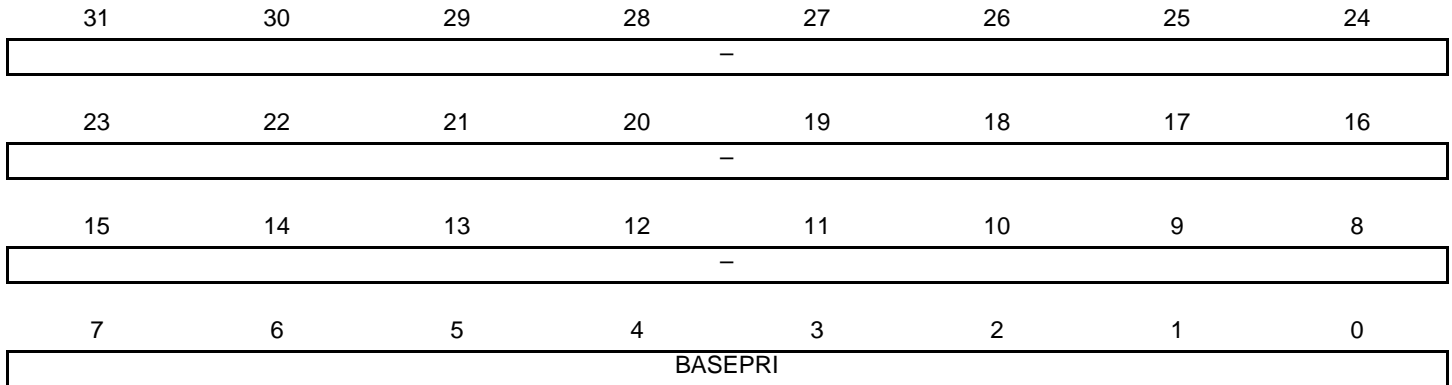

The BASEPRI register defines the minimum priority for exception processing. When BASEPRI is set to a nonzero value, it prevents the activation of all exceptions with same or lower priority level as the BASEPRI value.

- **BASEPRI**

Priority mask bits:

0x0000 = no effect.

Nonzero = defines the base priority for exception processing.

The processor does not process any exception with a priority value greater than or equal to BASEPRI.

This field is similar to the priority fields in the interrupt priority registers. The processor implements only bits[7:4] of this field, bits[3:0] read as zero and ignore writes. See ["Interrupt Priority Registers"](#) for more information. Remember that higher priority field values correspond to lower exception priorities.

11.4.1.16 CONTROL Register

Name: CONTROL
Access: Read-write
Reset: 0x00000000

31	30	29	28	27	26	25	24
—							
23	22	21	20	19	18	17	16
—							
15	14	13	12	11	10	9	8
—							
7	6	5	4	3	2	1	0
—					—	SPSEL	nPRIV

The CONTROL register controls the stack used and the privilege level for software execution when the processor is in Thread mode.

- **SPSEL: Active Stack Pointer**

Defines the current stack:

0: MSP is the current stack pointer.

1: PSP is the current stack pointer.

In Handler mode, this bit reads as zero and ignores writes. The Cortex-M4 updates this bit automatically on exception return.

- **nPRIV: Thread Mode Privilege Level**

Defines the Thread mode privilege level:

0: privileged.

1: unprivileged.

Handler mode always uses the MSP, so the processor ignores explicit writes to the active stack pointer bit of the CONTROL register when in Handler mode. The exception entry and return mechanisms update the CONTROL register based on the EXC_RETURN value.

In an OS environment, ARM recommends that threads running in Thread mode use the process stack, and the kernel and exception handlers use the main stack.

By default, the Thread mode uses the MSP. To switch the stack pointer used in Thread mode to the PSP, either:

- use the MSR instruction to set the Active stack pointer bit to 1, see “MSR” , or
- perform an exception return to Thread mode with the appropriate EXC_RETURN value, see Table 11-10.

Note: When changing the stack pointer, the software must use an ISB instruction immediately after the MSR instruction. This ensures that instructions after the ISB execute using the new stack pointer. See “ISB” .

11.4.1.17 Exceptions and Interrupts

The Cortex-M4 processor supports interrupts and system exceptions. The processor and the *Nested Vectored Interrupt Controller* (NVIC) prioritize and handle all exceptions. An exception changes the normal flow of software control. The processor uses the Handler mode to handle all exceptions except for reset. See [“Exception Entry”](#) and [“Exception Return”](#) for more information.

The NVIC registers control interrupt handling. See [“Nested Vectored Interrupt Controller \(NVIC\)”](#) for more information.

11.4.1.18 Data Types

The processor supports the following data types:

- 32-bit words
- 16-bit halfwords
- 8-bit bytes
- The processor manages all data memory accesses as little-endian. Instruction memory and *Private Peripheral Bus* (PPB) accesses are always little-endian. See [“Memory Regions, Types and Attributes”](#) for more information.

11.4.1.19 Cortex Microcontroller Software Interface Standard (CMSIS)

For a Cortex-M4 microcontroller system, the *Cortex Microcontroller Software Interface Standard* (CMSIS) defines:

- a common way to:
 - access peripheral registers
 - define exception vectors
- the names of:
 - the registers of the core peripherals
 - the core exception vectors
- a device-independent interface for RTOS kernels, including a debug channel.

The CMSIS includes address definitions and data structures for the core peripherals in the Cortex-M4 processor.

The CMSIS simplifies the software development by enabling the reuse of template code and the combination of CMSIS-compliant software components from various middleware vendors. Software vendors can expand the CMSIS to include their peripheral definitions and access functions for those peripherals.

This document includes the register names defined by the CMSIS, and gives short descriptions of the CMSIS functions that address the processor core and the core peripherals.

Note: This document uses the register short names defined by the CMSIS. In a few cases, these differ from the architectural short names that might be used in other documents.

The following sections give more information about the CMSIS:

- [Section 11.5.3 “Power Management Programming Hints”](#)
- [Section 11.6.2 “CMSIS Functions”](#)
- [Section 11.8.2.1 “NVIC Programming Hints”](#) .

11.4.2 Memory Model

This section describes the processor memory map, the behavior of memory accesses, and the bit-banding features. The processor has a fixed memory map that provides up to 4GB of addressable memory.

Figure 11-3. Memory Map

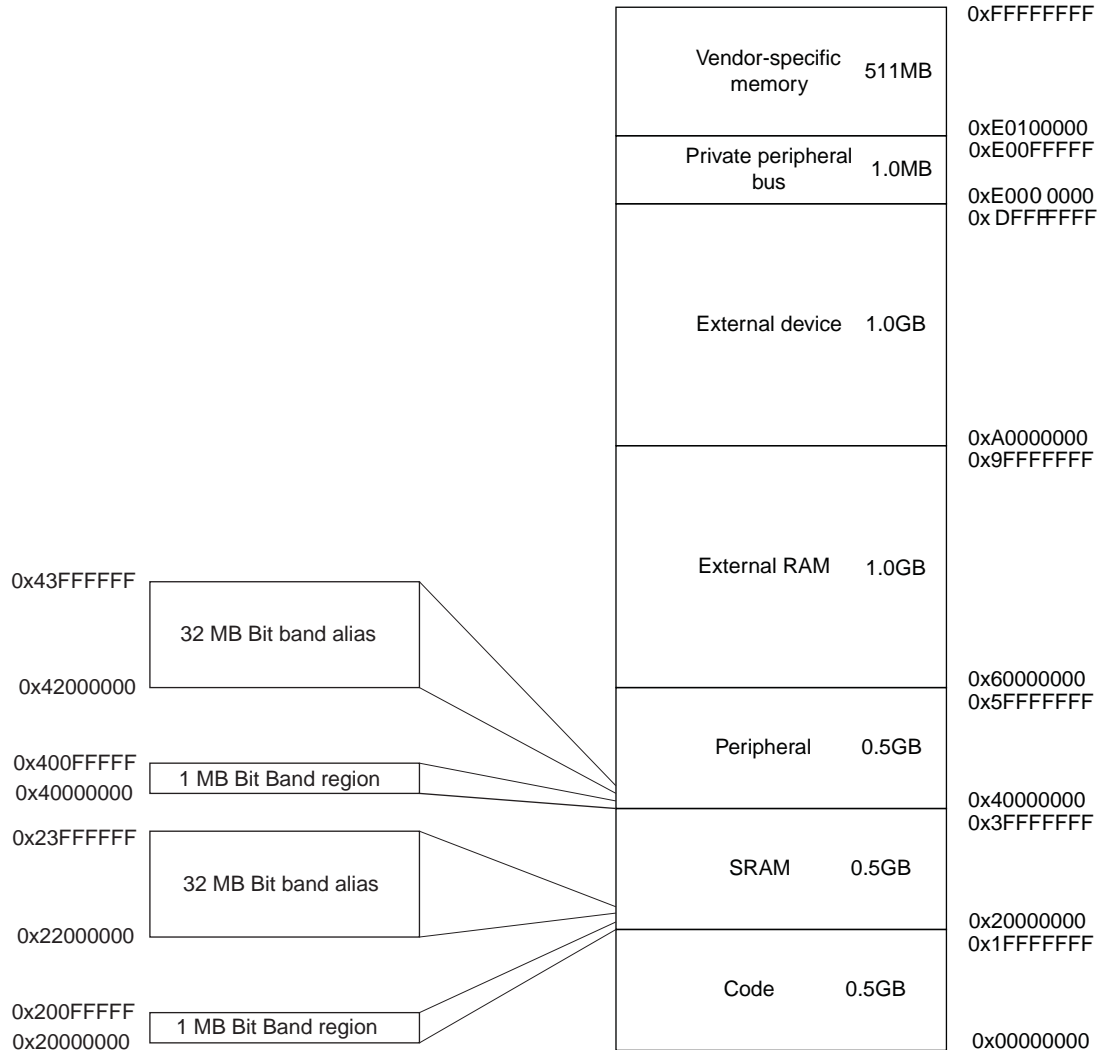

The regions for SRAM and peripherals include bit-band regions. Bit-banding provides atomic operations to bit data, see [“Bit-banding”](#).

The processor reserves regions of the *Private peripheral bus* (PPB) address range for core peripheral registers.

This memory mapping is generic to ARM Cortex-M4 products. To get the specific memory mapping of this product, refer to the Memories section of the datasheet.

11.4.2.1 Memory Regions, Types and Attributes

The memory map and the programming of the MPU split the memory map into regions. Each region has a defined memory type, and some regions have additional memory attributes. The memory type and attributes determine the behavior of accesses to the region.

Memory Types

- **Normal**
The processor can re-order transactions for efficiency, or perform speculative reads.
- **Device**
The processor preserves transaction order relative to other transactions to Device or Strongly-ordered memory.
- **Strongly-ordered**
The processor preserves transaction order relative to all other transactions.

The different ordering requirements for Device and Strongly-ordered memory mean that the memory system can buffer a write to Device memory, but must not buffer a write to Strongly-ordered memory.

Additional Memory Attributes

- **Shareable**
For a shareable memory region, the memory system provides data synchronization between bus masters in a system with multiple bus masters, for example, a processor with a DMA controller.
Strongly-ordered memory is always shareable.
If multiple bus masters can access a non-shareable memory region, the software must ensure data coherency between the bus masters.
- **Execute Never (XN)**
Means the processor prevents instruction accesses. A fault exception is generated only on execution of an instruction executed from an XN region.

11.4.2.2 Memory System Ordering of Memory Accesses

For most memory accesses caused by explicit memory access instructions, the memory system does not guarantee that the order in which the accesses complete matches the program order of the instructions, providing this does not affect the behavior of the instruction sequence. Normally, if correct program execution depends on two memory accesses completing in program order, the software must insert a memory barrier instruction between the memory access instructions, see [“Software Ordering of Memory Accesses”](#) .

However, the memory system does guarantee some ordering of accesses to Device and Strongly-ordered memory. For two memory access instructions A1 and A2, if A1 occurs before A2 in program order, the ordering of the memory accesses is described below.

Table 11-3. Ordering of the Memory Accesses Caused by Two Instructions

A1	A2	Normal Access	Device Access		Strongly-ordered Access
			Non-shareable	Shareable	
Normal Access		–	–	–	–
Device access, non-shareable		–	<	–	<
Device access, shareable		–	–	<	<
Strongly-ordered access		–	<	<	<

Where:

- Means that the memory system does not guarantee the ordering of the accesses.
- < Means that accesses are observed in program order, that is, A1 is always observed before A2.

11.4.2.3 Behavior of Memory Accesses

The behavior of accesses to each region in the memory map is:

Table 11-4. Memory Access Behavior

Address Range	Memory Region	Memory Type	XN	Description
0x00000000 - 0x1FFFFFFF	Code	Normal ⁽¹⁾	-	Executable region for program code. Data can also be put here.
0x20000000 - 0x3FFFFFFF	SRAM	Normal ⁽¹⁾	-	Executable region for data. Code can also be put here. This region includes bit band and bit band alias areas, see Table 11-6 .
0x40000000 - 0x5FFFFFFF	Peripheral	Device ⁽¹⁾	XN	This region includes bit band and bit band alias areas, see Table 11-6 .
0x60000000 - 0x9FFFFFFF	External RAM	Normal ⁽¹⁾	-	Executable region for data.
0xA0000000 - 0xDFFFFFFF	External device	Device ⁽¹⁾	XN	External Device memory
0xE0000000 - 0xE0FFFFFF	Private Peripheral Bus	Strongly-ordered ⁽¹⁾	XN	This region includes the NVIC, System timer, and system control block.
0xE0100000 - 0xFFFFFFFF	Reserved	Device ⁽¹⁾	XN	Reserved

Note: 1. See [“Memory Regions, Types and Attributes”](#) for more information.

The Code, SRAM, and external RAM regions can hold programs. However, ARM recommends that programs always use the Code region. This is because the processor has separate buses that enable instruction fetches and data accesses to occur simultaneously.

The MPU can override the default memory access behavior described in this section. For more information, see [“Memory Protection Unit \(MPU\)”](#).

Additional Memory Access Constraints For Shared Memory

When a system includes shared memory, some memory regions have additional access constraints, and some regions are subdivided, as [Table 11-5](#) shows:

Table 11-5. Memory Region Shareability Policies

Address Range	Memory Region	Memory Type	Shareability	
0x00000000-0x1FFFFFFF	Code	Normal ⁽¹⁾	-	⁽²⁾
0x20000000-0x3FFFFFFF	SRAM	Normal ⁽¹⁾	-	⁽²⁾
0x40000000-0x5FFFFFFF	Peripheral	Device ⁽¹⁾	-	

Table 11-5. Memory Region Shareability Policies (Continued)

Address Range	Memory Region	Memory Type	Shareability	
0x60000000-0x7FFFFFFF	External RAM	Normal ⁽¹⁾	-	WBWA ⁽²⁾
0x80000000-0x9FFFFFFF				WT ⁽²⁾
0xA0000000-0xBFFFFFFF	External device	Device ⁽¹⁾	Shareable ⁽¹⁾	-
0xC0000000-0xDFFFFFFF			Non-shareable ⁽¹⁾	
0xE0000000-0xE00FFFFF	Private Peripheral Bus	Strongly- ordered ⁽¹⁾	Shareable ⁽¹⁾	-
0xE0100000-0xFFFFFFFF	Vendor-specific device	Device ⁽¹⁾	-	-

Notes: 1. See “[Memory Regions, Types and Attributes](#)” for more information.

2. WT = Write through, no write allocate. WBWA = Write back, write allocate. See the “[Glossary](#)” for more information.

Instruction Prefetch And Branch Prediction

The Cortex-M4 processor:

- prefetches instructions ahead of execution
- speculatively prefetches from branch target addresses.

11.4.2.4 Software Ordering of Memory Accesses

The order of instructions in the program flow does not always guarantee the order of the corresponding memory transactions. This is because:

- the processor can reorder some memory accesses to improve efficiency, providing this does not affect the behavior of the instruction sequence.
- the processor has multiple bus interfaces
- memory or devices in the memory map have different wait states
- some memory accesses are buffered or speculative.

“[Memory System Ordering of Memory Accesses](#)” describes the cases where the memory system guarantees the order of memory accesses. Otherwise, if the order of memory accesses is critical, the software must include memory barrier instructions to force that ordering. The processor provides the following memory barrier instructions:

DMB

The *Data Memory Barrier* (DMB) instruction ensures that outstanding memory transactions complete before subsequent memory transactions. See “[DMB](#)” .

DSB

The *Data Synchronization Barrier* (DSB) instruction ensures that outstanding memory transactions complete before subsequent instructions execute. See “[DSB](#)” .

ISB

The *Instruction Synchronization Barrier* (ISB) ensures that the effect of all completed memory transactions is recognizable by subsequent instructions. See “[ISB](#)” .

Use a DSB followed by an ISB instruction or exception return to ensure that the new MPU configuration is used by subsequent instructions.

11.4.2.5 Bit-banding

A bit-band region maps each word in a *bit-band alias* region to a single bit in the *bit-band region*. The bit-band regions occupy the lowest 1 MB of the SRAM and peripheral memory regions.

The memory map has two 32 MB alias regions that map to two 1 MB bit-band regions:

- accesses to the 32 MB SRAM alias region map to the 1 MB SRAM bit-band region, as shown in [Table 11-6](#).
- accesses to the 32 MB peripheral alias region map to the 1 MB peripheral bit-band region, as shown in [Table 11-7](#).

Table 11-6. SRAM Memory Bit-banding Regions

Address Range	Memory Region	Instruction and Data Accesses
0x20000000-0x200FFFFFF	SRAM bit-band region	Direct accesses to this memory range behave as SRAM memory accesses, but this region is also bit-addressable through bit-band alias.
0x22000000-0x23FFFFFF	SRAM bit-band alias	Data accesses to this region are remapped to bit-band region. A write operation is performed as read-modify-write. Instruction accesses are not remapped.

Table 11-7. Peripheral Memory Bit-banding Regions

Address Range	Memory Region	Instruction and Data Accesses
0x40000000-0x400FFFFFF	Peripheral bit-band alias	Direct accesses to this memory range behave as peripheral memory accesses, but this region is also bit-addressable through bit-band alias.
0x42000000-0x43FFFFFF	Peripheral bit-band region	Data accesses to this region are remapped to bit-band region. A write operation is performed as read-modify-write. Instruction accesses are not permitted.

- Notes:
1. A word access to the SRAM or peripheral bit-band alias regions map to a single bit in the SRAM or peripheral bit-band region.
 2. Bit-band accesses can use byte, halfword, or word transfers. The bit-band transfer size matches the transfer size of the instruction making the bit-band access.

The following formula shows how the alias region maps onto the bit-band region:

$$\text{bit_word_offset} = (\text{byte_offset} \times 32) + (\text{bit_number} \times 4)$$

$$\text{bit_word_addr} = \text{bit_band_base} + \text{bit_word_offset}$$

where:

- *Bit_word_offset* is the position of the target bit in the bit-band memory region.
- *Bit_word_addr* is the address of the word in the alias memory region that maps to the targeted bit.

- `Bit_band_base` is the starting address of the alias region.
- `Byte_offset` is the number of the byte in the bit-band region that contains the targeted bit.
- `Bit_number` is the bit position, 0-7, of the targeted bit.

Figure 11-4 shows examples of bit-band mapping between the SRAM bit-band alias region and the SRAM bit-band region:

- The alias word at `0x23FFFE0` maps to bit[0] of the bit-band byte at `0x200FFFFF`: $0x23FFFE0 = 0x22000000 + (0xFFFF * 32) + (0 * 4)$.
- The alias word at `0x23FFFFC` maps to bit[7] of the bit-band byte at `0x200FFFFF`: $0x23FFFFC = 0x22000000 + (0xFFFF * 32) + (7 * 4)$.
- The alias word at `0x2200000` maps to bit[0] of the bit-band byte at `0x20000000`: $0x2200000 = 0x22000000 + (0 * 32) + (0 * 4)$.
- The alias word at `0x220001C` maps to bit[7] of the bit-band byte at `0x20000000`: $0x220001C = 0x22000000 + (0 * 32) + (7 * 4)$.

Figure 11-4. Bit-band Mapping

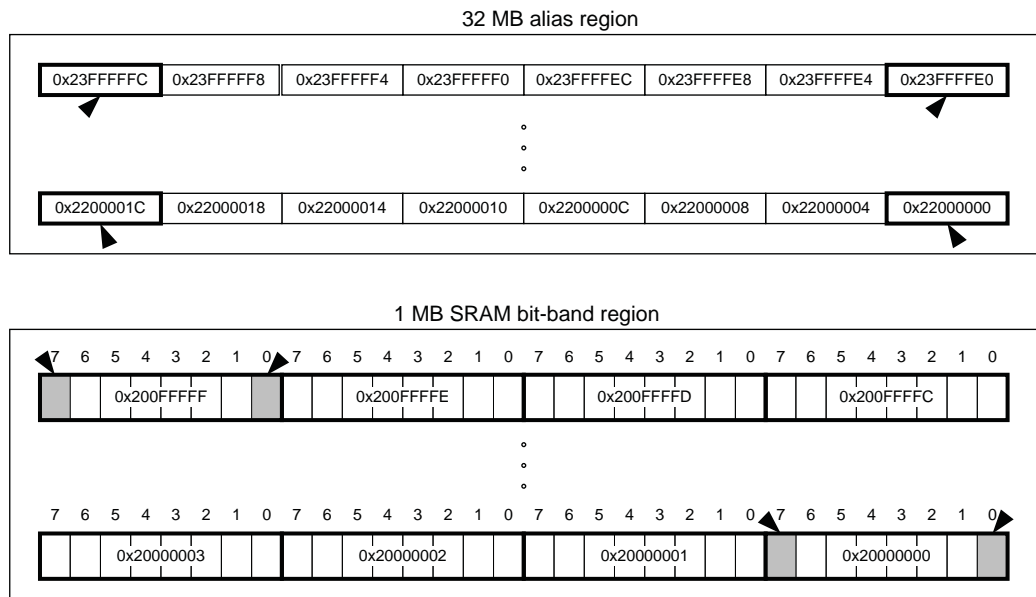

Directly Accessing an Alias Region

Writing to a word in the alias region updates a single bit in the bit-band region.

Bit[0] of the value written to a word in the alias region determines the value written to the targeted bit in the bit-band region. Writing a value with bit[0] set to 1 writes a 1 to the bit-band bit, and writing a value with bit[0] set to 0 writes a 0 to the bit-band bit.

Bits[31:1] of the alias word have no effect on the bit-band bit. Writing 0x01 has the same effect as writing 0xFF. Writing 0x00 has the same effect as writing 0x0E.

Reading a word in the alias region:

- 0x00000000 indicates that the targeted bit in the bit-band region is set to 0
- 0x00000001 indicates that the targeted bit in the bit-band region is set to 1

Directly Accessing a Bit-band Region

“Behavior of Memory Accesses” describes the behavior of direct byte, halfword, or word accesses to the bit-band regions.

11.4.2.6 Memory Endianness

The processor views memory as a linear collection of bytes numbered in ascending order from zero. For example, bytes 0-3 hold the first stored word, and bytes 4-7 hold the second stored word. “Little-endian Format” describes how words of data are stored in memory.

Little-endian Format

In little-endian format, the processor stores the least significant byte of a word at the lowest-numbered byte, and the most significant byte at the highest-numbered byte. For example:

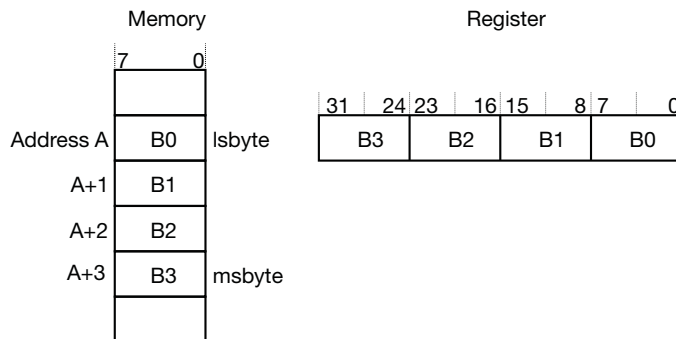

11.4.2.7 Synchronization Primitives

The Cortex-M4 instruction set includes pairs of *synchronization primitives*. These provide a non-blocking mechanism that a thread or process can use to obtain exclusive access to a memory location. The software can use them to perform a guaranteed read-modify-write memory update sequence, or for a semaphore mechanism.

A pair of synchronization primitives comprises:

A Load-exclusive Instruction, used to read the value of a memory location, requesting exclusive access to that location.

A Store-Exclusive instruction, used to attempt to write to the same memory location, returning a status bit to a register. If this bit is:

- 0: it indicates that the thread or process gained exclusive access to the memory, and the write succeeds,
- 1: it indicates that the thread or process did not gain exclusive access to the memory, and no write is performed.

The pairs of Load-Exclusive and Store-Exclusive instructions are:

- the word instructions LDREX and STREX
- the halfword instructions LDREXH and STREXH
- the byte instructions LDREXB and STREXB.

The software must use a Load-Exclusive instruction with the corresponding Store-Exclusive instruction.

To perform an exclusive read-modify-write of a memory location, the software must:

1. Use a Load-Exclusive instruction to read the value of the location.
2. Update the value, as required.
3. Use a Store-Exclusive instruction to attempt to write the new value back to the memory location
4. Test the returned status bit. If this bit is:
 - 0: The read-modify-write completed successfully.
 - 1: No write was performed. This indicates that the value returned at step 1 might be out of date. The software must retry the read-modify-write sequence.

The software can use the synchronization primitives to implement a semaphore as follows:

1. Use a Load-Exclusive instruction to read from the semaphore address to check whether the semaphore is free.
2. If the semaphore is free, use a Store-Exclusive instruction to write the claim value to the semaphore address.
3. If the returned status bit from step 2 indicates that the Store-Exclusive instruction succeeded then the software has claimed the semaphore. However, if the Store-Exclusive instruction failed, another process might have claimed the semaphore after the software performed the first step.

The Cortex-M4 includes an exclusive access monitor, that tags the fact that the processor has executed a Load-Exclusive instruction. If the processor is part of a multiprocessor system, the system also globally tags the memory locations addressed by exclusive accesses by each processor.

The processor removes its exclusive access tag if:

- It executes a CLREX instruction
- It executes a Store-Exclusive instruction, regardless of whether the write succeeds.
- An exception occurs. This means that the processor can resolve semaphore conflicts between different threads.

In a multiprocessor implementation:

- Executing a CLREX instruction removes only the local exclusive access tag for the processor
- executing a Store-Exclusive instruction, or an exception, removes the local exclusive access tags, and all global exclusive access tags for the processor.

For more information about the synchronization primitive instructions, see [Section 11.6.4.8 "LDREX and STREX"](#) and [Section 11.6.4.9 "CLREX"](#).

11.4.2.8 Programming Hints for the Synchronization Primitives

ISO/IEC C cannot directly generate the exclusive access instructions. CMSIS provides intrinsic functions for generation of these instructions:

Table 11-8. CMSIS Functions for Exclusive Access Instructions

Instruction	CMSIS Function
LDREX	uint32_t __LDREXW (uint32_t *addr)
LDREXH	uint16_t __LDREXH (uint16_t *addr)
LDREXB	uint8_t __LDREXB (uint8_t *addr)

Table 11-8. CMSIS Functions for Exclusive Access Instructions (Continued)

Instruction	CMSIS Function
STREX	uint32_t __STREXW (uint32_t value, uint32_t *addr)
STREXH	uint32_t __STREXH (uint16_t value, uint16_t *addr)
STREXB	uint32_t __STREXB (uint8_t value, uint8_t *addr)
CLREX	void __CLREX (void)

The actual exclusive access instruction generated depends on the data type of the pointer passed to the intrinsic function. For example, the following C code generates the require LDREXB operation:

```
__ldrex((volatile char *) 0xFF);
```

11.4.3 Exception Model

This section describes the exception model.

11.4.3.1 Exception States

Each exception is in one of the following states:

Inactive

The exception is not active and not pending.

Pending

The exception is waiting to be serviced by the processor.

An interrupt request from a peripheral or from software can change the state of the corresponding interrupt to pending.

Active

An exception is being serviced by the processor but has not completed.

An exception handler can interrupt the execution of another exception handler. In this case, both exceptions are in the active state.

Active and Pending

The exception is being serviced by the processor and there is a pending exception from the same source.

11.4.3.2 Exception Types

The exception types are:

Reset

Reset is invoked on power up or a warm reset. The exception model treats reset as a special form of exception. When reset is asserted, the operation of the processor stops, potentially at any point in an instruction. When reset is deasserted, execution restarts from the address provided by the reset entry in the vector table. Execution restarts as privileged execution in Thread mode.

Non Maskable Interrupt (NMI)

A non maskable interrupt (NMI) can be signalled by a peripheral or triggered by software. This is the highest priority exception other than reset. It is permanently enabled and has a fixed priority of -2.

NMIs cannot be:

- Masked or prevented from activation by any other exception.
- Preempted by any exception other than Reset.

Hard Fault

A hard fault is an exception that occurs because of an error during exception processing, or because an exception cannot be managed by any other exception mechanism. Hard Faults have a fixed priority of -1, meaning they have higher priority than any exception with configurable priority.

Memory Management Fault (MemManage)

A Memory Management Fault is an exception that occurs because of a memory protection related fault. The MPU or the fixed memory protection constraints determines this fault, for both instruction and data memory transactions. This fault is used to abort instruction accesses to *Execute Never* (XN) memory regions, even if the MPU is disabled.

Bus Fault

A Bus Fault is an exception that occurs because of a memory related fault for an instruction or data memory transaction. This might be from an error detected on a bus in the memory system.

Usage Fault

A Usage Fault is an exception that occurs because of a fault related to an instruction execution. This includes:

- an undefined instruction
- an illegal unaligned access
- an invalid state on instruction execution
- an error on exception return.

The following can cause a Usage Fault when the core is configured to report them:

- an unaligned address on word and halfword memory access
- a division by zero.

SVCall

A *supervisor call* (SVC) is an exception that is triggered by the SVC instruction. In an OS environment, applications can use SVC instructions to access OS kernel functions and device drivers.

PendSV

PendSV is an interrupt-driven request for system-level service. In an OS environment, use PendSV for context switching when no other exception is active.

SysTick

A SysTick exception is an exception the system timer generates when it reaches zero. Software can also generate a SysTick exception. In an OS environment, the processor can use this exception as system tick.

Interrupt (IRQ)

A interrupt, or IRQ, is an exception signalled by a peripheral, or generated by a software request. All interrupts are asynchronous to instruction execution. In the system, peripherals use interrupts to communicate with the processor.

Table 11-9. Properties of the Different Exception Types

Exception Number ⁽¹⁾	Irq Number ⁽¹⁾	Exception Type	Priority	Vector Address or Offset ⁽²⁾	Activation
1	-	Reset	-3, the highest	0x00000004	Asynchronous
2	-14	NMI	-2	0x00000008	Asynchronous
3	-13	Hard fault	-1	0x0000000C	-

Table 11-9. Properties of the Different Exception Types (Continued)

Exception Number ⁽¹⁾	Irq Number ⁽¹⁾	Exception Type	Priority	Vector Address or Offset ⁽²⁾	Activation
4	-12	Memory management fault	Configurable ⁽³⁾	0x00000010	Synchronous
5	-11	Bus fault	Configurable ⁽³⁾	0x00000014	Synchronous when precise, asynchronous when imprecise
6	-10	Usage fault	Configurable ⁽³⁾	0x00000018	Synchronous
7-10	-	-	-	Reserved	-
11	-5	SVCALL	Configurable ⁽³⁾	0x0000002C	Synchronous
12-13	-	-	-	Reserved	-
14	-2	PendSV	Configurable ⁽³⁾	0x00000038	Asynchronous
15	-1	SysTick	Configurable ⁽³⁾	0x0000003C	Asynchronous
16 and above	0 and above	Interrupt (IRQ)	Configurable ⁽⁴⁾	0x00000040 and above ⁽⁵⁾	Asynchronous

- Notes:
1. To simplify the software layer, the CMSIS only uses IRQ numbers and therefore uses negative values for exceptions other than interrupts. The IPSR returns the Exception number, see [“Interrupt Program Status Register”](#) .
 2. See [“Vector Table”](#) for more information
 3. See [“System Handler Priority Registers”](#)
 4. See [“Interrupt Priority Registers”](#)
 5. Increasing in steps of 4.

For an asynchronous exception, other than reset, the processor can execute another instruction between when the exception is triggered and when the processor enters the exception handler.

Privileged software can disable the exceptions that [Table 11-9](#) shows as having configurable priority, see:

- [“System Handler Control and State Register”](#)
- [“Interrupt Clear-enable Registers”](#) .

For more information about hard faults, memory management faults, bus faults, and usage faults, see [“Fault Handling”](#) .

11.4.3.3 Exception Handlers

The processor handles exceptions using:

- **Interrupt Service Routines (ISRs)**
Interrupts IRQ0 to IRQ34 are the exceptions handled by ISRs.
- **Fault Handlers**
Hard fault, memory management fault, usage fault, bus fault are fault exceptions handled by the fault handlers.
- **System Handlers**
NMI, PendSV, SVCALL SysTick, and the fault exceptions are all system exceptions that are handled by system handlers.

11.4.3.4 Vector Table

The vector table contains the reset value of the stack pointer, and the start addresses, also called exception vectors, for all exception handlers. [Figure 11-5](#) shows the order of the exception vectors in the vector table. The least-significant bit of each vector must be 1, indicating that the exception handler is Thumb code.

Figure 11-5. Vector Table

Exception number	IRQ number	Offset	Vector
255	239	0x03FC	IRQ239
.	.	.	.
.	.	.	.
.	.	.	.
18	2	0x004C	IRQ2
17	1	0x0048	IRQ1
16	0	0x0044	IRQ0
15	-1	0x0040	SysTick
14	-2	0x003C	PendSV
13		0x0038	Reserved
12			Reserved for Debug
11	-5	0x002C	SVCall
10			Reserved
9			
8			
7			
6	-10	0x0018	Usage fault
5	-11	0x0014	Bus fault
4	-12	0x0010	Memory management fault
3	-13	0x000C	Hard fault
2	-14	0x0008	NMI
1		0x0004	Reset
		0x0000	Initial SP value

On system reset, the vector table is fixed at address 0x00000000. Privileged software can write to the SCB_VTOR register to relocate the vector table start address to a different memory location, in the range 0x00000080 to 0x3FFFFFF80, see [“Vector Table Offset Register”](#).

11.4.3.5 Exception Priorities

As [Table 11-9](#) shows, all exceptions have an associated priority, with:

- a lower priority value indicating a higher priority
- configurable priorities for all exceptions except Reset, Hard fault and NMI.

If the software does not configure any priorities, then all exceptions with a configurable priority have a priority of 0. For information about configuring exception priorities see [“System Handler Priority Registers”](#), and [“Interrupt Priority Registers”](#).

Note: Configurable priority values are in the range 0-15. This means that the Reset, Hard fault, and NMI exceptions, with fixed negative priority values, always have higher priority than any other exception.

For example, assigning a higher priority value to IRQ[0] and a lower priority value to IRQ[1] means that IRQ[1] has higher priority than IRQ[0]. If both IRQ[1] and IRQ[0] are asserted, IRQ[1] is processed before IRQ[0].

If multiple pending exceptions have the same priority, the pending exception with the lowest exception number takes precedence. For example, if both IRQ[0] and IRQ[1] are pending and have the same priority, then IRQ[0] is processed before IRQ[1].

When the processor is executing an exception handler, the exception handler is preempted if a higher priority exception occurs. If an exception occurs with the same priority as the exception being handled, the handler is not preempted, irrespective of the exception number. However, the status of the new interrupt changes to pending.

11.4.3.6 Interrupt Priority Grouping

To increase priority control in systems with interrupts, the NVIC supports priority grouping. This divides each interrupt priority register entry into two fields:

- an upper field that defines the *group priority*
- a lower field that defines a *subpriority* within the group.

Only the group priority determines preemption of interrupt exceptions. When the processor is executing an interrupt exception handler, another interrupt with the same group priority as the interrupt being handled does not preempt the handler.

If multiple pending interrupts have the same group priority, the subpriority field determines the order in which they are processed. If multiple pending interrupts have the same group priority and subpriority, the interrupt with the lowest IRQ number is processed first.

For information about splitting the interrupt priority fields into group priority and subpriority, see [“Application Interrupt and Reset Control Register”](#).

11.4.3.7 Exception Entry and Return

Descriptions of exception handling use the following terms:

Preemption

When the processor is executing an exception handler, an exception can preempt the exception handler if its priority is higher than the priority of the exception being handled. See [“Interrupt Priority Grouping”](#) for more information about preemption by an interrupt.

When one exception preempts another, the exceptions are called nested exceptions. See [“Exception Entry”](#) for more information.

Return

This occurs when the exception handler is completed, and:

- there is no pending exception with sufficient priority to be serviced
- the completed exception handler was not handling a late-arriving exception.

The processor pops the stack and restores the processor state to the state it had before the interrupt occurred. See [“Exception Return”](#) for more information.

Tail-chaining

This mechanism speeds up exception servicing. On completion of an exception handler, if there is a pending exception that meets the requirements for exception entry, the stack pop is skipped and control transfers to the new exception handler.

Late-arriving

This mechanism speeds up preemption. If a higher priority exception occurs during state saving for a previous exception, the processor switches to handle the higher priority exception and initiates the vector fetch for that exception. State saving is not affected by late arrival because the state saved is the same for both exceptions. Therefore the state saving continues uninterrupted. The processor can accept a late arriving exception until the first instruction of the exception handler of the original exception enters the execute stage of the processor. On return from the exception handler of the late-arriving exception, the normal tail-chaining rules apply.

Exception Entry

An Exception entry occurs when there is a pending exception with sufficient priority and either the processor is in Thread mode, or the new exception is of a higher priority than the exception being handled, in which case the new exception preempts the original exception.

When one exception preempts another, the exceptions are nested.

Sufficient priority means that the exception has more priority than any limits set by the mask registers, see [“Exception Mask Registers”](#). An exception with less priority than this is pending but is not handled by the processor.

When the processor takes an exception, unless the exception is a tail-chained or a late-arriving exception, the processor pushes information onto the current stack. This operation is referred as *stacking* and the structure of eight data words is referred to as *stack frame*.

Figure 11-6. Exception Stack Frame

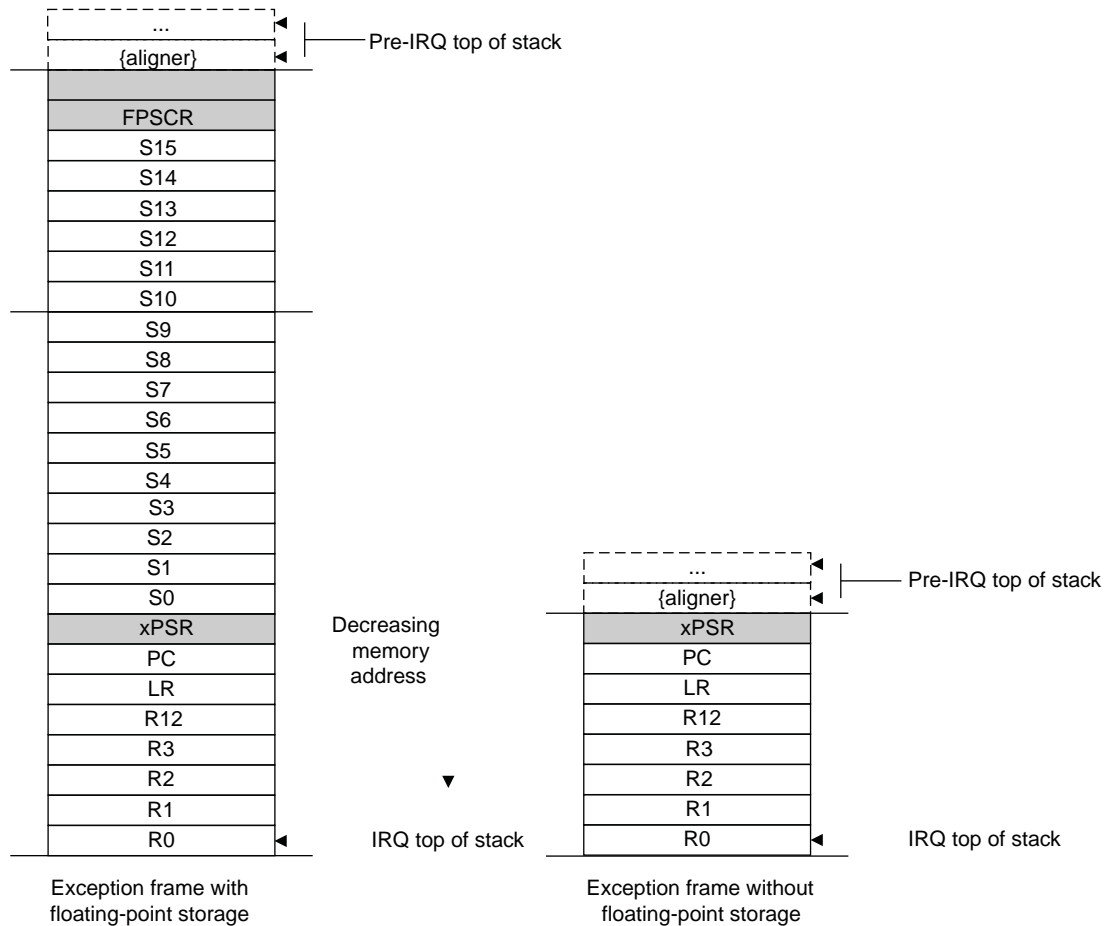

Immediately after stacking, the stack pointer indicates the lowest address in the stack frame. The alignment of the stack frame is controlled via the STKALIGN bit of the Configuration Control Register (CCR).

The stack frame includes the return address. This is the address of the next instruction in the interrupted program. This value is restored to the PC at exception return so that the interrupted program resumes.

In parallel to the stacking operation, the processor performs a vector fetch that reads the exception handler start address from the vector table. When stacking is complete, the processor starts executing the exception handler. At the same time, the processor writes an EXC_RETURN value to the LR. This indicates which stack pointer corresponds to the stack frame and what operation mode the processor was in before the entry occurred.

If no higher priority exception occurs during the exception entry, the processor starts executing the exception handler and automatically changes the status of the corresponding pending interrupt to active.

If another higher priority exception occurs during the exception entry, the processor starts executing the exception handler for this exception and does not change the pending status of the earlier exception. This is the late arrival case.

Exception Return

An Exception return occurs when the processor is in Handler mode and executes one of the following instructions to load the EXC_RETURN value into the PC:

- an LDM or POP instruction that loads the PC
- an LDR instruction with the PC as the destination.
- a BX instruction using any register.

EXC_RETURN is the value loaded into the LR on exception entry. The exception mechanism relies on this value to detect when the processor has completed an exception handler. The lowest five bits of this value provide information on the return stack and processor mode. [Table 11-10](#) shows the EXC_RETURN values with a description of the exception return behavior.

All EXC_RETURN values have bits[31:5] set to one. When this value is loaded into the PC, it indicates to the processor that the exception is complete, and the processor initiates the appropriate exception return sequence.

Table 11-10. Exception Return Behavior

EXC_RETURN[31:0]	Description
0xFFFFFFFF1	Return to Handler mode, exception return uses non-floating-point state from the MSP and execution uses MSP after return.
0xFFFFFFFF9	Return to Thread mode, exception return uses non-floating-point state from MSP and execution uses MSP after return.
0xFFFFFFFFD	Return to Thread mode, exception return uses non-floating-point state from the PSP and execution uses PSP after return.

11.4.3.8 Fault Handling

Faults are a subset of the exceptions, see [“Exception Model”](#). The following generate a fault:

- a bus error on:
 - an instruction fetch or vector table load
 - a data access
- an internally-detected error such as an undefined instruction
- an attempt to execute an instruction from a memory region marked as *Non-Executable (XN)*.
- a privilege violation or an attempt to access an unmanaged region causing an MPU fault.

Fault Types

[Table 11-11](#) shows the types of fault, the handler used for the fault, the corresponding fault status register, and the register bit that indicates that the fault has occurred. See [“Configurable Fault Status Register”](#) for more information about the fault status registers.

Table 11-11. Faults

Fault	Handler	Bit Name	Fault Status Register
Bus error on a vector read	Hard fault	VECTTBL	“Hard Fault Status Register”
Fault escalated to a hard fault		FORCED	

Table 11-11. Faults (Continued)

Fault	Handler	Bit Name	Fault Status Register
MPU or default memory map mismatch:	Memory management fault	-	-
on instruction access		IACCVIOL	"MMFSR: Memory Management Fault Status Subregister"
on data access		DACCVIOL ⁽²⁾	
during exception stacking		MSTKERR	
during exception unstacking		MUNSKERR	
during lazy floating-point state preservation		MLSPERR	
Bus error:	Bus fault	-	-
during exception stacking		STKERR	"BFSR: Bus Fault Status Subregister"
during exception unstacking		UNSTKERR	
during instruction prefetch		IBUSERR	
during lazy floating-point state preservation		LSPERR	
Precise data bus error		PRECISERR	
Imprecise data bus error		IMPRECISERR	
Attempt to access a coprocessor	Usage fault	NOCP	
Undefined instruction		UNDEFINSTR	
Attempt to enter an invalid instruction set state ⁽¹⁾		INVSTATE	
Invalid EXC_RETURN value		INVPC	
Illegal unaligned load or store		UNALIGNED	
Divide By 0		DIVBYZERO	

Notes: 1. Occurs on an access to an XN region even if the processor does not include an MPU or the MPU is disabled.

2. Attempt to use an instruction set other than the Thumb instruction set, or return to a non load/store-multiple instruction with ICI continuation.

Fault Escalation and Hard Faults

All faults exceptions except for hard fault have configurable exception priority, see "System Handler Priority Registers". The software can disable the execution of the handlers for these faults, see "System Handler Control and State Register".

Usually, the exception priority, together with the values of the exception mask registers, determines whether the processor enters the fault handler, and whether a fault handler can preempt another fault handler, as described in "Exception Model".

In some situations, a fault with configurable priority is treated as a hard fault. This is called *priority escalation*, and the fault is described as *escalated to hard fault*. Escalation to hard fault occurs when:

- A fault handler causes the same kind of fault as the one it is servicing. This escalation to hard fault occurs because a fault handler cannot preempt itself; it must have the same priority as the current priority level.
- A fault handler causes a fault with the same or lower priority as the fault it is servicing. This is because the handler for the new fault cannot preempt the currently executing fault handler.
- An exception handler causes a fault for which the priority is the same as or lower than the currently executing exception.

- A fault occurs and the handler for that fault is not enabled.

If a bus fault occurs during a stack push when entering a bus fault handler, the bus fault does not escalate to a hard fault. This means that if a corrupted stack causes a fault, the fault handler executes even though the stack push for the handler failed. The fault handler operates but the stack contents are corrupted.

Note: Only Reset and NMI can preempt the fixed priority hard fault. A hard fault can preempt any exception other than Reset, NMI, or another hard fault.

Fault Status Registers and Fault Address Registers

The fault status registers indicate the cause of a fault. For bus faults and memory management faults, the fault address register indicates the address accessed by the operation that caused the fault, as shown in [Table 11-12](#).

Table 11-12. Fault Status and Fault Address Registers

Handler	Status Register Name	Address Register Name	Register Description
Hard fault	SCB_HFSR	-	"Hard Fault Status Register"
Memory management fault	MMFSR	SCB_MMFAR	"MMFSR: Memory Management Fault Status Subregister" "MemManage Fault Address Register"
Bus fault	BFSR	SCB_BFAR	"BFSR: Bus Fault Status Subregister" "Bus Fault Address Register"
Usage fault	UFSR	-	"UFSR: Usage Fault Status Subregister"

Lockup

The processor enters a lockup state if a hard fault occurs when executing the NMI or hard fault handlers. When the processor is in lockup state, it does not execute any instructions. The processor remains in lockup state until either:

- it is reset
- an NMI occurs
- it is halted by a debugger.

Note: If the lockup state occurs from the NMI handler, a subsequent NMI does not cause the processor to leave the lockup state.

11.5 Power Management

The Cortex-M4 processor sleep modes reduce the power consumption:

- Sleep mode stops the processor clock
- Deep sleep mode stops the system clock and switches off the PLL and flash memory.

The SLEEPDEEP bit of the SCR selects which sleep mode is used; see [“System Control Register”](#).

This section describes the mechanisms for entering sleep mode, and the conditions for waking up from sleep mode.

11.5.1 Entering Sleep Mode

This section describes the mechanisms software can use to put the processor into sleep mode.

The system can generate spurious wakeup events, for example a debug operation wakes up the processor. Therefore, the software must be able to put the processor back into sleep mode after such an event. A program might have an idle loop to put the processor back to sleep mode.

11.5.1.1 *Wait for Interrupt*

The *wait for interrupt* instruction, WFI, causes immediate entry to sleep mode. When the processor executes a WFI instruction it stops executing instructions and enters sleep mode. See [“WFI”](#) for more information.

11.5.1.2 *Wait For Event*

The *wait for event* instruction, WFE, causes entry to sleep mode conditional on the value of an one-bit event register. When the processor executes a WFE instruction, it checks this register:

- if the register is 0, the processor stops executing instructions and enters sleep mode
- if the register is 1, the processor clears the register to 0 and continues executing instructions without entering sleep mode.

See [“WFE”](#) for more information.

11.5.1.3 *Sleep-On-Exit*

If the SLEEPONEXIT bit of the SCR is set to 1 when the processor completes the execution of an exception handler, it returns to Thread mode and immediately enters sleep mode. Use this mechanism in applications that only require the processor to run when an exception occurs.

11.5.2 Wakeup From Sleep Mode

The conditions for the processor to wake up depend on the mechanism that cause it to enter sleep mode.

11.5.2.1 *Wakeup from WFI or Sleep-on-exit*

Normally, the processor wakes up only when it detects an exception with sufficient priority to cause exception entry.

Some embedded systems might have to execute system restore tasks after the processor wakes up, and before it executes an interrupt handler. To achieve this, set the PRIMASK bit to 1 and the FAULTMASK bit to 0. If an interrupt arrives that is enabled and has a higher priority than the current exception priority, the processor wakes up but does not execute the interrupt handler until the processor sets PRIMASK to zero. For more information about PRIMASK and FAULTMASK, see [“Exception Mask Registers”](#).

11.5.2.2 *Wakeup from WFE*

The processor wakes up if:

- it detects an exception with sufficient priority to cause an exception entry
- it detects an external event signal. See [“External Event Input”](#)
- in a multiprocessor system, another processor in the system executes an SEV instruction.

In addition, if the SEVONPEND bit in the SCR is set to 1, any new pending interrupt triggers an event and wakes up the processor, even if the interrupt is disabled or has insufficient priority to cause an exception entry. For more information about the SCR, see [“System Control Register”](#).

11.5.2.3 *External Event Input*

The processor provides an external event input signal. Peripherals can drive this signal, either to wake the processor from WFE, or to set the internal WFE event register to 1 to indicate that the processor must not enter sleep mode on a later WFE instruction. See [“Wait For Event”](#) for more information.

11.5.3 **Power Management Programming Hints**

ISO/IEC C cannot directly generate the WFI and WFE instructions. The CMSIS provides the following functions for these instructions:

```
void __WFE(void) // Wait for Event
void __WFI(void) // Wait for Interrupt
```

11.6 Cortex-M4 Instruction Set

11.6.1 Instruction Set Summary

The processor implements a version of the Thumb instruction set. [Table 11-13](#) lists the supported instructions.

- angle brackets, <>, enclose alternative forms of the operand
- braces, {}, enclose optional operands
- the Operands column is not exhaustive
- Op2 is a flexible second operand that can be either a register or a constant
- most instructions can use an optional condition code suffix.

For more information on the instructions and operands, see the instruction descriptions.

Table 11-13. Cortex-M4 Instructions

Mnemonic	Operands	Description	Flags
ADC, ADCS	{Rd,} Rn, Op2	Add with Carry	N,Z,C,V
ADD, ADDS	{Rd,} Rn, Op2	Add	N,Z,C,V
ADD, ADDW	{Rd,} Rn, #imm12	Add	N,Z,C,V
ADR	Rd, label	Load PC-relative address	-
AND, ANDS	{Rd,} Rn, Op2	Logical AND	N,Z,C
ASR, ASRS	Rd, Rm, <Rs #n>	Arithmetic Shift Right	N,Z,C
B	label	Branch	-
BFC	Rd, #lsb, #width	Bit Field Clear	-
BFI	Rd, Rn, #lsb, #width	Bit Field Insert	-
BIC, BICS	{Rd,} Rn, Op2	Bit Clear	N,Z,C
BKPT	#imm	Breakpoint	-
BL	label	Branch with Link	-
BLX	Rm	Branch indirect with Link	-
BX	Rm	Branch indirect	-
CBNZ	Rn, label	Compare and Branch if Non Zero	-
CBZ	Rn, label	Compare and Branch if Zero	-
CLREX	-	Clear Exclusive	-
CLZ	Rd, Rm	Count leading zeros	-
CMN	Rn, Op2	Compare Negative	N,Z,C,V
CMP	Rn, Op2	Compare	N,Z,C,V
CPSID	i	Change Processor State, Disable Interrupts	-
CPSIE	i	Change Processor State, Enable Interrupts	-
DMB	-	Data Memory Barrier	-
DSB	-	Data Synchronization Barrier	-
EOR, EORS	{Rd,} Rn, Op2	Exclusive OR	N,Z,C
ISB	-	Instruction Synchronization Barrier	-

Table 11-13. Cortex-M4 Instructions (Continued)

Mnemonic	Operands	Description	Flags
IT	-	If-Then condition block	-
LDM	Rn{!}, reglist	Load Multiple registers, increment after	-
LDMDB, LDMEA	Rn{!}, reglist	Load Multiple registers, decrement before	-
LDMFD, LDMIA	Rn{!}, reglist	Load Multiple registers, increment after	-
LDR	Rt, [Rn, #offset]	Load Register with word	-
LDRB, LDRBT	Rt, [Rn, #offset]	Load Register with byte	-
LDRD	Rt, Rt2, [Rn, #offset]	Load Register with two bytes	-
LDREX	Rt, [Rn, #offset]	Load Register Exclusive	-
LDREXB	Rt, [Rn]	Load Register Exclusive with byte	-
LDREXH	Rt, [Rn]	Load Register Exclusive with halfword	-
LDRH, LDRHT	Rt, [Rn, #offset]	Load Register with halfword	-
LDRSB, DRSBT	Rt, [Rn, #offset]	Load Register with signed byte	-
LDRSH, LDRSHT	Rt, [Rn, #offset]	Load Register with signed halfword	-
LDRT	Rt, [Rn, #offset]	Load Register with word	-
LSL, LSLS	Rd, Rm, <Rs #n>	Logical Shift Left	N,Z,C
LSR, LSRS	Rd, Rm, <Rs #n>	Logical Shift Right	N,Z,C
MLA	Rd, Rn, Rm, Ra	Multiply with Accumulate, 32-bit result	-
MLS	Rd, Rn, Rm, Ra	Multiply and Subtract, 32-bit result	-
MOV, MOVS	Rd, Op2	Move	N,Z,C
MOVT	Rd, #imm16	Move Top	-
MOVW, MOV	Rd, #imm16	Move 16-bit constant	N,Z,C
MRS	Rd, spec_reg	Move from special register to general register	-
MSR	spec_reg, Rm	Move from general register to special register	N,Z,C,V
MUL, MULS	{Rd,} Rn, Rm	Multiply, 32-bit result	N,Z
MVN, MVNS	Rd, Op2	Move NOT	N,Z,C
NOP	-	No Operation	-
ORN, ORNS	{Rd,} Rn, Op2	Logical OR NOT	N,Z,C
ORR, ORRS	{Rd,} Rn, Op2	Logical OR	N,Z,C
PKHTB, PKHBT	{Rd,} Rn, Rm, Op2	Pack Halfword	-
POP	reglist	Pop registers from stack	-
PUSH	reglist	Push registers onto stack	-
QADD	{Rd,} Rn, Rm	Saturating double and Add	Q
QADD16	{Rd,} Rn, Rm	Saturating Add 16	-
QADD8	{Rd,} Rn, Rm	Saturating Add 8	-
QASX	{Rd,} Rn, Rm	Saturating Add and Subtract with Exchange	-
QDADD	{Rd,} Rn, Rm	Saturating Add	Q

Table 11-13. Cortex-M4 Instructions (Continued)

Mnemonic	Operands	Description	Flags
QDSUB	{Rd,} Rn, Rm	Saturating double and Subtract	Q
QSAX	{Rd,} Rn, Rm	Saturating Subtract and Add with Exchange	-
QSUB	{Rd,} Rn, Rm	Saturating Subtract	Q
QSUB16	{Rd,} Rn, Rm	Saturating Subtract 16	-
QSUB8	{Rd,} Rn, Rm	Saturating Subtract 8	-
RBIT	Rd, Rn	Reverse Bits	-
REV	Rd, Rn	Reverse byte order in a word	-
REV16	Rd, Rn	Reverse byte order in each halfword	-
REVSH	Rd, Rn	Reverse byte order in bottom halfword and sign extend	-
ROR, RORS	Rd, Rm, <Rs #n>	Rotate Right	N,Z,C
RRX, RRXS	Rd, Rm	Rotate Right with Extend	N,Z,C
RSB, RSBS	{Rd,} Rn, Op2	Reverse Subtract	N,Z,C,V
SADD16	{Rd,} Rn, Rm	Signed Add 16	GE
SADD8	{Rd,} Rn, Rm	Signed Add 8 and Subtract with Exchange	GE
SASX	{Rd,} Rn, Rm	Signed Add	GE
SBC, SBCS	{Rd,} Rn, Op2	Subtract with Carry	N,Z,C,V
SBFX	Rd, Rn, #lsb, #width	Signed Bit Field Extract	-
SDIV	{Rd,} Rn, Rm	Signed Divide	-
SEL	{Rd,} Rn, Rm	Select bytes	-
SEV	-	Send Event	-
SHADD16	{Rd,} Rn, Rm	Signed Halving Add 16	-
SHADD8	{Rd,} Rn, Rm	Signed Halving Add 8	-
SHASX	{Rd,} Rn, Rm	Signed Halving Add and Subtract with Exchange	-
SHSAX	{Rd,} Rn, Rm	Signed Halving Subtract and Add with Exchange	-
SHSUB16	{Rd,} Rn, Rm	Signed Halving Subtract 16	-
SHSUB8	{Rd,} Rn, Rm	Signed Halving Subtract 8	-
SMLABB, SMLABT, SMLATB, SMLATT	Rd, Rn, Rm, Ra	Signed Multiply Accumulate Long (halfwords)	Q
SMLAD, SMLADX	Rd, Rn, Rm, Ra	Signed Multiply Accumulate Dual	Q
SMLAL	RdLo, RdHi, Rn, Rm	Signed Multiply with Accumulate (32 x 32 + 64), 64-bit result	-
SMLALBB, SMLALBT, SMLALTB, SMLALTT	RdLo, RdHi, Rn, Rm	Signed Multiply Accumulate Long, halfwords	-
SMLALD, SMLALDX	RdLo, RdHi, Rn, Rm	Signed Multiply Accumulate Long Dual	-
SMLAWB, SMLAWT	Rd, Rn, Rm, Ra	Signed Multiply Accumulate, word by halfword	Q
SMLSD	Rd, Rn, Rm, Ra	Signed Multiply Subtract Dual	Q
SMLSLD	RdLo, RdHi, Rn, Rm	Signed Multiply Subtract Long Dual	-
SMMLA	Rd, Rn, Rm, Ra	Signed Most significant word Multiply Accumulate	-
SMMLS, SMMLR	Rd, Rn, Rm, Ra	Signed Most significant word Multiply Subtract	-
SMMUL, SMMULR	{Rd,} Rn, Rm	Signed Most significant word Multiply	-
SMUAD	{Rd,} Rn, Rm	Signed dual Multiply Add	Q

Table 11-13. Cortex-M4 Instructions (Continued)

Mnemonic	Operands	Description	Flags
SMULBB, SMULBT SMULTB, SMULTT	{Rd,} Rn, Rm	Signed Multiply (halfwords)	-
SMULL	RdLo, RdHi, Rn, Rm	Signed Multiply (32 x 32), 64-bit result	-
SMULWB, SMULWT	{Rd,} Rn, Rm	Signed Multiply word by halfword	-
SMUSD, SMUSDX	{Rd,} Rn, Rm	Signed dual Multiply Subtract	-
SSAT	Rd, #n, Rm {,shift #s}	Signed Saturate	Q
SSAT16	Rd, #n, Rm	Signed Saturate 16	Q
SSAX	{Rd,} Rn, Rm	Signed Subtract and Add with Exchange	GE
SSUB16	{Rd,} Rn, Rm	Signed Subtract 16	-
SSUB8	{Rd,} Rn, Rm	Signed Subtract 8	-
STM	Rn{!}, reglist	Store Multiple registers, increment after	-
STMDB, STMEA	Rn{!}, reglist	Store Multiple registers, decrement before	-
STMFD, STMIA	Rn{!}, reglist	Store Multiple registers, increment after	-
STR	Rt, [Rn, #offset]	Store Register word	-
STRB, STRBT	Rt, [Rn, #offset]	Store Register byte	-
STRD	Rt, Rt2, [Rn, #offset]	Store Register two words	-
STREX	Rd, Rt, [Rn, #offset]	Store Register Exclusive	-
STREXB	Rd, Rt, [Rn]	Store Register Exclusive byte	-
STREXH	Rd, Rt, [Rn]	Store Register Exclusive halfword	-
STRH, STRHT	Rt, [Rn, #offset]	Store Register halfword	-
STRT	Rt, [Rn, #offset]	Store Register word	-
SUB, SUBS	{Rd,} Rn, Op2	Subtract	N,Z,C,V
SUB, SUBW	{Rd,} Rn, #imm12	Subtract	N,Z,C,V
SVC	#imm	Supervisor Call	-
SXTAB	{Rd,} Rn, Rm,{,ROR #}	Extend 8 bits to 32 and add	-
SXTAB16	{Rd,} Rn, Rm,{,ROR #}	Dual extend 8 bits to 16 and add	-
SXTAH	{Rd,} Rn, Rm,{,ROR #}	Extend 16 bits to 32 and add	-
SXTB16	{Rd,} Rm {,ROR #n}	Signed Extend Byte 16	-
SXTB	{Rd,} Rm {,ROR #n}	Sign extend a byte	-
SXTH	{Rd,} Rm {,ROR #n}	Sign extend a halfword	-
TBB	[Rn, Rm]	Table Branch Byte	-
TBH	[Rn, Rm, LSL #1]	Table Branch Halfword	-
TEQ	Rn, Op2	Test Equivalence	N,Z,C
TST	Rn, Op2	Test	N,Z,C
UADD16	{Rd,} Rn, Rm	Unsigned Add 16	GE
UADD8	{Rd,} Rn, Rm	Unsigned Add 8	GE
USAX	{Rd,} Rn, Rm	Unsigned Subtract and Add with Exchange	GE
UHADD16	{Rd,} Rn, Rm	Unsigned Halving Add 16	-
UHADD8	{Rd,} Rn, Rm	Unsigned Halving Add 8	-
UHASX	{Rd,} Rn, Rm	Unsigned Halving Add and Subtract with Exchange	-
UHSAX	{Rd,} Rn, Rm	Unsigned Halving Subtract and Add with Exchange	-

Table 11-13. Cortex-M4 Instructions (Continued)

Mnemonic	Operands	Description	Flags
UHSUB16	{Rd,} Rn, Rm	Unsigned Halving Subtract 16	-
UHSUB8	{Rd,} Rn, Rm	Unsigned Halving Subtract 8	-
UBFX	Rd, Rn, #lsb, #width	Unsigned Bit Field Extract	-
UDIV	{Rd,} Rn, Rm	Unsigned Divide	-
UMAAL	RdLo, RdHi, Rn, Rm	Unsigned Multiply Accumulate Accumulate Long (32 x 32 + 32 +32), 64-bit result	-
UMLAL	RdLo, RdHi, Rn, Rm	Unsigned Multiply with Accumulate (32 x 32 + 64), 64-bit result	-
UMULL	RdLo, RdHi, Rn, Rm	Unsigned Multiply (32 x 32), 64-bit result	-
UQADD16	{Rd,} Rn, Rm	Unsigned Saturating Add 16	-
UQADD8	{Rd,} Rn, Rm	Unsigned Saturating Add 8	-
UQASX	{Rd,} Rn, Rm	Unsigned Saturating Add and Subtract with Exchange	-
UQSAX	{Rd,} Rn, Rm	Unsigned Saturating Subtract and Add with Exchange	-
UQSUB16	{Rd,} Rn, Rm	Unsigned Saturating Subtract 16	-
UQSUB8	{Rd,} Rn, Rm	Unsigned Saturating Subtract 8	-
USAD8	{Rd,} Rn, Rm	Unsigned Sum of Absolute Differences	-
USADA8	{Rd,} Rn, Rm, Ra	Unsigned Sum of Absolute Differences and Accumulate	-
USAT	Rd, #n, Rm {,shift #s}	Unsigned Saturate	Q
USAT16	Rd, #n, Rm	Unsigned Saturate 16	Q
UASX	{Rd,} Rn, Rm	Unsigned Add and Subtract with Exchange	GE
USUB16	{Rd,} Rn, Rm	Unsigned Subtract 16	GE
USUB8	{Rd,} Rn, Rm	Unsigned Subtract 8	GE
UXTAB	{Rd,} Rn, Rm,{,ROR #}	Rotate, extend 8 bits to 32 and Add	-
UXTAB16	{Rd,} Rn, Rm,{,ROR #}	Rotate, dual extend 8 bits to 16 and Add	-
UXTAH	{Rd,} Rn, Rm,{,ROR #}	Rotate, unsigned extend and Add Halfword	-
UXTB	{Rd,} Rm {,ROR #n}	Zero extend a byte	-
UXTB16	{Rd,} Rm {,ROR #n}	Unsigned Extend Byte 16	-
UXTH	{Rd,} Rm {,ROR #n}	Zero extend a halfword	-
WFE	-	Wait For Event	-
WFI	-	Wait For Interrupt	-

11.6.2 CMSIS Functions

ISO/IEC cannot directly access some Cortex-M4 instructions. This section describes intrinsic functions that can generate these instructions, provided by the CMIS and that might be provided by a C compiler. If a C compiler does not support an appropriate intrinsic function, the user might have to use inline assembler to access some instructions.

The CMSIS provides the following intrinsic functions to generate instructions that ISO/IEC C code cannot directly access:

Table 11-14. CMSIS Functions to Generate some Cortex-M4 Instructions

Instruction	CMSIS Function
CPSIE I	void __enable_irq(void)
CPSID I	void __disable_irq(void)
CPSIE F	void __enable_fault_irq(void)
CPSID F	void __disable_fault_irq(void)
ISB	void __ISB(void)
DSB	void __DSB(void)
DMB	void __DMB(void)
REV	uint32_t __REV(uint32_t int value)
REV16	uint32_t __REV16(uint32_t int value)
REVSH	uint32_t __REVSH(uint32_t int value)
RBIT	uint32_t __RBIT(uint32_t int value)
SEV	void __SEV(void)
WFE	void __WFE(void)
WFI	void __WFI(void)

The CMSIS also provides a number of functions for accessing the special registers using MRS and MSR instructions:

Table 11-15. CMSIS Intrinsic Functions to Access the Special Registers

Special Register	Access	CMSIS Function
PRIMASK	Read	uint32_t __get_PRIMASK (void)
	Write	void __set_PRIMASK (uint32_t value)
FAULTMASK	Read	uint32_t __get_FAULTMASK (void)
	Write	void __set_FAULTMASK (uint32_t value)
BASEPRI	Read	uint32_t __get_BASEPRI (void)
	Write	void __set_BASEPRI (uint32_t value)
CONTROL	Read	uint32_t __get_CONTROL (void)
	Write	void __set_CONTROL (uint32_t value)
MSP	Read	uint32_t __get_MSP (void)
	Write	void __set_MSP (uint32_t TopOfMainStack)
PSP	Read	uint32_t __get_PSP (void)
	Write	void __set_PSP (uint32_t TopOfProcStack)

11.6.3 Instruction Descriptions

11.6.3.1 Operands

An instruction operand can be an ARM register, a constant, or another instruction-specific parameter. Instructions act on the operands and often store the result in a destination register. When there is a destination register in the instruction, it is usually specified before the operands.

Operands in some instructions are flexible, can either be a register or a constant. See “[Flexible Second Operand](#)” .

11.6.3.2 Restrictions when Using PC or SP

Many instructions have restrictions on whether the *Program Counter* (PC) or *Stack Pointer* (SP) for the operands or destination register can be used. See instruction descriptions for more information.

Note: Bit[0] of any address written to the PC with a BX, BLX, LDM, LDR, or POP instruction must be 1 for correct execution, because this bit indicates the required instruction set, and the Cortex-M4 processor only supports Thumb instructions.

11.6.3.3 Flexible Second Operand

Many general data processing instructions have a flexible second operand. This is shown as *Operand2* in the descriptions of the syntax of each instruction.

Operand2 can be a:

- “[Constant](#)”
- “[Register with Optional Shift](#)”

Constant

Specify an *Operand2* constant in the form:

`#constant`

where *constant* can be:

- any constant that can be produced by shifting an 8-bit value left by any number of bits within a 32-bit word
- any constant of the form 0x00XY00XY
- any constant of the form 0xXY00XY00
- any constant of the form 0xXYXYXYXY.

Note: In the constants shown above, X and Y are hexadecimal digits.

In addition, in a small number of instructions, *constant* can take a wider range of values. These are described in the individual instruction descriptions.

When an *Operand2* constant is used with the instructions MOVNS, MVNS, ANDS, ORRS, ORNS, EORS, BICS, TEQ or TST, the carry flag is updated to bit[31] of the constant, if the constant is greater than 255 and can be produced by shifting an 8-bit value. These instructions do not affect the carry flag if *Operand2* is any other constant.

Instruction Substitution

The assembler might be able to produce an equivalent instruction in cases where the user specifies a constant that is not permitted. For example, an assembler might assemble the instruction `CMP Rd, #0xFFFFFFFF` as the equivalent instruction `CMN Rd, #0x2`.

Register with Optional Shift

Specify an Operand2 register in the form:

$Rm \{, shift\}$

where:

Rm	is the register holding the data for the second operand.
shift	is an optional shift to be applied to Rm . It can be one of:
ASR # n	arithmetic shift right n bits, $1 \leq n \leq 32$.
LSL # n	logical shift left n bits, $1 \leq n \leq 31$.
LSR # n	logical shift right n bits, $1 \leq n \leq 32$.
ROR # n	rotate right n bits, $1 \leq n \leq 31$.
RRX	rotate right one bit, with extend.
-	if omitted, no shift occurs, equivalent to LSL #0.

If the user omits the shift, or specifies LSL #0, the instruction uses the value in Rm .

If the user specifies a shift, the shift is applied to the value in Rm , and the resulting 32-bit value is used by the instruction. However, the contents in the register Rm remains unchanged. Specifying a register with shift also updates the carry flag when used with certain instructions. For information on the shift operations and how they affect the carry flag, see [“Flexible Second Operand”](#).

11.6.3.4 Shift Operations

Register shift operations move the bits in a register left or right by a specified number of bits, the *shift length*. Register shift can be performed:

- Directly by the instructions ASR, LSR, LSL, ROR, and RRX, and the result is written to a destination register
- During the calculation of *Operand2* by the instructions that specify the second operand as a register with shift. See [“Flexible Second Operand”](#). The result is used by the instruction.

The permitted shift lengths depend on the shift type and the instruction. If the shift length is 0, no shift occurs. Register shift operations update the carry flag except when the specified shift length is 0. The following sub-sections describe the various shift operations and how they affect the carry flag. In these descriptions, Rm is the register containing the value to be shifted, and n is the shift length.

ASR

Arithmetic shift right by n bits moves the left-hand 32- n bits of the register, Rm , to the right by n places, into the right-hand 32- n bits of the result. And it copies the original bit[31] of the register into the left-hand n bits of the result. See [Figure 11-7](#).

The ASR # n operation can be used to divide the value in the register Rm by 2^n , with the result being rounded towards negative-infinity.

When the instruction is ASRS or when ASR # n is used in *Operand2* with the instructions MOV_S, MVNS, AND_S, ORR_S, ORN_S, EOR_S, BIC_S, TEQ or TST, the carry flag is updated to the last bit shifted out, bit[$n-1$], of the register Rm .

- If n is 32 or more, then all the bits in the result are set to the value of bit[31] of Rm .
- If n is 32 or more and the carry flag is updated, it is updated to the value of bit[31] of Rm .

Figure 11-7. ASR #3

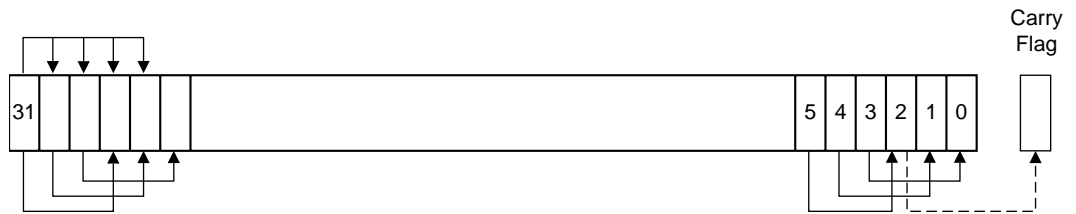

LSR

Logical shift right by n bits moves the left-hand $32-n$ bits of the register Rm , to the right by n places, into the right-hand $32-n$ bits of the result. And it sets the left-hand n bits of the result to 0. See [Figure 11-8](#).

The LSR # n operation can be used to divide the value in the register Rm by 2^n , if the value is regarded as an unsigned integer.

When the instruction is LSRS or when LSR # n is used in *Operand2* with the instructions MOV_S, MVNS, AND_S, ORR_S, ORN_S, EOR_S, BIC_S, TEQ or TST, the carry flag is updated to the last bit shifted out, bit[$n-1$], of the register Rm .

- If n is 32 or more, then all the bits in the result are cleared to 0.
- If n is 33 or more and the carry flag is updated, it is updated to 0.

Figure 11-8. LSR #3

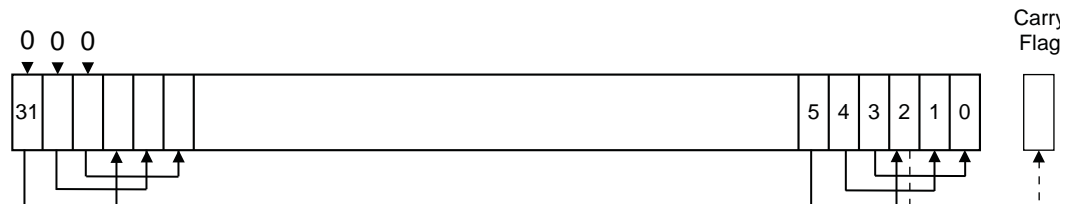

LSL

Logical shift left by n bits moves the right-hand $32-n$ bits of the register Rm , to the left by n places, into the left-hand $32-n$ bits of the result. And it sets the right-hand n bits of the result to 0. See [Figure 11-9](#).

The LSL # n operation can be used to multiply the value in the register Rm by 2^n , if the value is regarded as an unsigned integer or a two's complement signed integer. Overflow can occur without warning.

When the instruction is LSLS or when LSL # n , with non-zero n , is used in *Operand2* with the instructions MOV_S, MVNS, AND_S, ORR_S, ORN_S, EOR_S, BIC_S, TEQ or TST, the carry flag is updated to the last bit shifted out, bit[$32-n$], of the register Rm . These instructions do not affect the carry flag when used with LSL #0.

- If n is 32 or more, then all the bits in the result are cleared to 0.
- If n is 33 or more and the carry flag is updated, it is updated to 0.

Figure 11-9. LSL #3

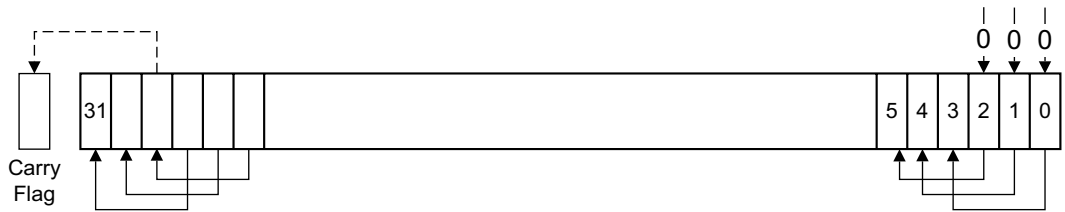

ROR

Rotate right by n bits moves the left-hand $32-n$ bits of the register Rm , to the right by n places, into the right-hand $32-n$ bits of the result. And it moves the right-hand n bits of the register into the left-hand n bits of the result. See [Figure 11-10](#).

When the instruction is RORS or when ROR # n is used in *Operand2* with the instructions MOVS, MVNS, ANDS, ORRS, ORNS, EORS, BICS, TEQ or TST, the carry flag is updated to the last bit rotation, bit[$n-1$], of the register Rm .

- If n is 32, then the value of the result is same as the value in Rm , and if the carry flag is updated, it is updated to bit[31] of Rm .
- ROR with shift length, n , more than 32 is the same as ROR with shift length $n-32$.

Figure 11-10. ROR #3

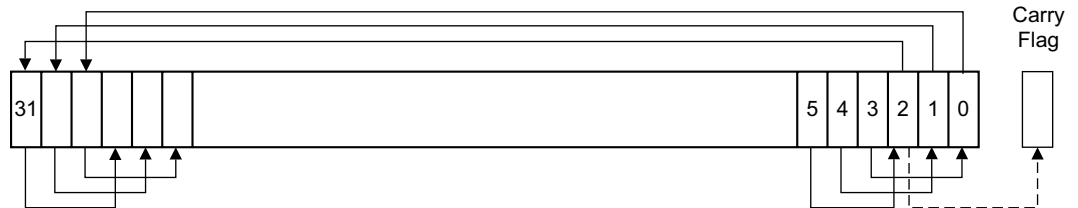

RRX

Rotate right with extend moves the bits of the register Rm to the right by one bit. And it copies the carry flag into bit[31] of the result. See [Figure 11-11](#).

When the instruction is RRXS or when RRX is used in *Operand2* with the instructions MOVS, MVNS, ANDS, ORRS, ORNS, EORS, BICS, TEQ or TST, the carry flag is updated to bit[0] of the register Rm .

Figure 11-11. RRX

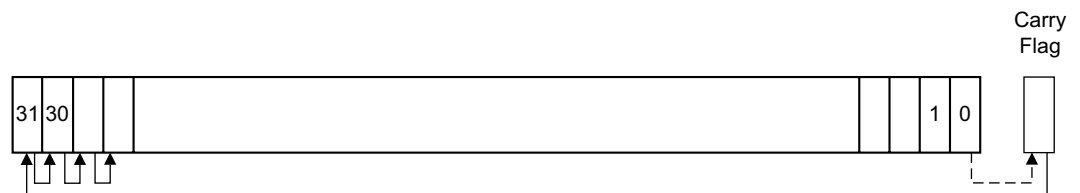

11.6.3.5 Address Alignment

An aligned access is an operation where a word-aligned address is used for a word, dual word, or multiple word access, or where a halfword-aligned address is used for a halfword access. Byte accesses are always aligned.

The Cortex-M4 processor supports unaligned access only for the following instructions:

- LDR, LDRT
- LDRH, LDRHT
- LDRSH, LDRSHT
- STR, STRT
- STRH, STRHT

All other load and store instructions generate a usage fault exception if they perform an unaligned access, and therefore their accesses must be address-aligned. For more information about usage faults, see [“Fault Handling”](#).

Unaligned accesses are usually slower than aligned accesses. In addition, some memory regions might not support unaligned accesses. Therefore, ARM recommends that programmers ensure that accesses are aligned. To avoid accidental generation of unaligned accesses, use the UNALIGN_TRP bit in the Configuration and Control Register to trap all unaligned accesses, see [“Configuration and Control Register”](#).

11.6.3.6 PC-relative Expressions

A PC-relative expression or *label* is a symbol that represents the address of an instruction or literal data. It is represented in the instruction as the PC value plus or minus a numeric offset. The assembler calculates the required offset from the label and the address of the current instruction. If the offset is too big, the assembler produces an error.

- For B, BL, CBNZ, and CBZ instructions, the value of the PC is the address of the current instruction plus 4 bytes.
- For all other instructions that use labels, the value of the PC is the address of the current instruction plus 4 bytes, with bit[1] of the result cleared to 0 to make it word-aligned.
- Your assembler might permit other syntaxes for PC-relative expressions, such as a label plus or minus a number, or an expression of the form [PC, #number].

11.6.3.7 Conditional Execution

Most data processing instructions can optionally update the condition flags in the *Application Program Status Register* (APSR) according to the result of the operation, see [“Application Program Status Register”](#). Some instructions update all flags, and some only update a subset. If a flag is not updated, the original value is preserved. See the instruction descriptions for the flags they affect.

An instruction can be executed conditionally, based on the condition flags set in another instruction, either:

- immediately after the instruction that updated the flags
- after any number of intervening instructions that have not updated the flags.

Conditional execution is available by using conditional branches or by adding condition code suffixes to instructions. See [Table 11-16](#) for a list of the suffixes to add to instructions to make them conditional instructions. The condition code suffix enables the processor to test a condition based on the flags. If the condition test of a conditional instruction fails, the instruction:

- does not execute
- does not write any value to its destination register
- does not affect any of the flags
- does not generate any exception.

Conditional instructions, except for conditional branches, must be inside an If-Then instruction block. See “” for more information and restrictions when using the IT instruction. Depending on the vendor, the assembler might automatically insert an IT instruction if there are conditional instructions outside the IT block.

The CBZ and CBNZ instructions are used to compare the value of a register against zero and branch on the result.

This section describes:

- “Condition Flags”
- “Condition Code Suffixes” .

Condition Flags

The APSR contains the following condition flags:

N	Set to 1 when the result of the operation was negative, cleared to 0 otherwise.
Z	Set to 1 when the result of the operation was zero, cleared to 0 otherwise.
C	Set to 1 when the operation resulted in a carry, cleared to 0 otherwise.
V	Set to 1 when the operation caused overflow, cleared to 0 otherwise.

For more information about the APSR, see “Program Status Register” .

A carry occurs:

- if the result of an addition is greater than or equal to 2^{32}
- if the result of a subtraction is positive or zero
- as the result of an inline barrel shifter operation in a move or logical instruction.

An overflow occurs when the sign of the result, in bit[31], does not match the sign of the result, had the operation been performed at infinite precision, for example:

- if adding two negative values results in a positive value
- if adding two positive values results in a negative value
- if subtracting a positive value from a negative value generates a positive value
- if subtracting a negative value from a positive value generates a negative value.

The Compare operations are identical to subtracting, for CMP, or adding, for CMN, except that the result is discarded. See the instruction descriptions for more information.

Note: Most instructions update the status flags only if the S suffix is specified. See the instruction descriptions for more information.

Condition Code Suffixes

The instructions that can be conditional have an optional condition code, shown in syntax descriptions as {cond}. Conditional execution requires a preceding IT instruction. An instruction with a condition code is only executed if the condition code flags in the APSR meet the specified condition. Table 11-16 shows the condition codes to use.

A conditional execution can be used with the IT instruction to reduce the number of branch instructions in code.

Table 11-16 also shows the relationship between condition code suffixes and the N, Z, C, and V flags.

Table 11-16. Condition Code Suffixes

Suffix	Flags	Meaning
EQ	Z = 1	Equal
NE	Z = 0	Not equal
CS or HS	C = 1	Higher or same, unsigned \geq
CC or LO	C = 0	Lower, unsigned $<$
MI	N = 1	Negative
PL	N = 0	Positive or zero
VS	V = 1	Overflow
VC	V = 0	No overflow
HI	C = 1 and Z = 0	Higher, unsigned $>$
LS	C = 0 or Z = 1	Lower or same, unsigned \leq
GE	N = V	Greater than or equal, signed \geq
LT	N \neq V	Less than, signed $<$
GT	Z = 0 and N = V	Greater than, signed $>$
LE	Z = 1 and N \neq V	Less than or equal, signed \leq
AL	Can have any value	Always. This is the default when no suffix is specified.

Absolute Value

The example below shows the use of a conditional instruction to find the absolute value of a number. $R0 = ABS(R1)$.

```

MOVVS    R0, R1           ; R0 = R1, setting flags
IT       MI              ; IT instruction for the negative condition
RSBMI   R0, R1, #0      ; If negative, R0 = -R1
    
```

Compare and Update Value

The example below shows the use of conditional instructions to update the value of R4 if the signed values R0 is greater than R1 and R2 is greater than R3.

```

CMP      R0, R1          ; Compare R0 and R1, setting flags
ITT     GT              ; IT instruction for the two GT conditions
CMPGT   R2, R3          ; If 'greater than', compare R2 and R3, setting flags
MOVGT   R4, R5          ; If still 'greater than', do R4 = R5
    
```

11.6.3.8 Instruction Width Selection

There are many instructions that can generate either a 16-bit encoding or a 32-bit encoding depending on the operands and destination register specified. For some of these instructions,

the user can force a specific instruction size by using an instruction width suffix. The `.W` suffix forces a 32-bit instruction encoding. The `.N` suffix forces a 16-bit instruction encoding.

If the user specifies an instruction width suffix and the assembler cannot generate an instruction encoding of the requested width, it generates an error.

Note: In some cases, it might be necessary to specify the `.W` suffix, for example if the operand is the label of an instruction or literal data, as in the case of branch instructions. This is because the assembler might not automatically generate the right size encoding.

To use an instruction width suffix, place it immediately after the instruction mnemonic and condition code, if any. The example below shows instructions with the instruction width suffix.

```
BCS.W label      ; creates a 32-bit instruction even for a short branch

ADDS.W R0, R0, R1 ; creates a 32-bit instruction even though the same
                  ; operation can be done by a 16-bit instruction
```

11.6.4 Memory Access Instructions

The table below shows the memory access instructions:

Table 11-17. Memory Access Instructions

Mnemonic	Description
ADR	Load PC-relative address
CLREX	Clear Exclusive
LDM{mode}	Load Multiple registers
LDR{type}	Load Register using immediate offset
LDR{type}	Load Register using register offset
LDR{type}T	Load Register with unprivileged access
LDR	Load Register using PC-relative address
LDRD	Load Register Dual
LDREX{type}	Load Register Exclusive
POP	Pop registers from stack
PUSH	Push registers onto stack
STM{mode}	Store Multiple registers
STR{type}	Store Register using immediate offset
STR{type}	Store Register using register offset
STR{type}T	Store Register with unprivileged access
STREX{type}	Store Register Exclusive

11.6.4.1 ADR

Load PC-relative address.

Syntax

```
ADR{cond} Rd, label
```

where:

cond is an optional condition code, see [“Conditional Execution”](#).

Rd is the destination register.

label is a PC-relative expression. See [“PC-relative Expressions”](#).

Operation

ADR determines the address by adding an immediate value to the PC, and writes the result to the destination register.

ADR produces position-independent code, because the address is PC-relative.

If ADR is used to generate a target address for a BX or BLX instruction, ensure that bit[0] of the address generated is set to 1 for correct execution.

Values of *label* must be within the range of -4095 to +4095 from the address in the PC.

Note: The user might have to use the *.W* suffix to get the maximum offset range or to generate addresses that are not word-aligned. See [“Instruction Width Selection”](#).

Restrictions

Rd must not be SP and must not be PC.

Condition Flags

This instruction does not change the flags.

Examples

```
ADR    R1, TextMessage    ; Write address value of a location labelled as  
                        ; TextMessage to R1
```

11.6.4.2 LDR and STR, Immediate Offset

Load and Store with immediate offset, pre-indexed immediate offset, or post-indexed immediate offset.

Syntax

```

op{type}{cond} Rt, [Rn {, #offset}]           ; immediate offset
op{type}{cond} Rt, [Rn, #offset]!           ; pre-indexed
op{type}{cond} Rt, [Rn], #offset            ; post-indexed
opD{cond} Rt, Rt2, [Rn {, #offset}]        ; immediate offset, two words
opD{cond} Rt, Rt2, [Rn, #offset]!         ; pre-indexed, two words
opD{cond} Rt, Rt2, [Rn], #offset          ; post-indexed, two words

```

where:

op is one of:

LDR Load Register.

STR Store Register.

type is one of:

B unsigned byte, zero extend to 32 bits on loads.

SB signed byte, sign extend to 32 bits (LDR only).

H unsigned halfword, zero extend to 32 bits on loads.

SH signed halfword, sign extend to 32 bits (LDR only).

- omit, for word.

cond is an optional condition code, see [“Conditional Execution”](#) .

Rt is the register to load or store.

Rn is the register on which the memory address is based.

offset is an offset from *Rn*. If *offset* is omitted, the address is the contents of *Rn*.

Rt2 is the additional register to load or store for two-word operations.

Operation

LDR instructions load one or two registers with a value from memory.

STR instructions store one or two register values to memory.

Load and store instructions with immediate offset can use the following addressing modes:

Offset Addressing

The offset value is added to or subtracted from the address obtained from the register *Rn*. The result is used as the address for the memory access. The register *Rn* is unaltered. The assembly language syntax for this mode is:

```
[Rn, #offset]
```

Pre-indexed Addressing

The offset value is added to or subtracted from the address obtained from the register Rn . The result is used as the address for the memory access and written back into the register Rn . The assembly language syntax for this mode is:

```
[Rn, #offset]!
```

Post-indexed Addressing

The address obtained from the register Rn is used as the address for the memory access. The offset value is added to or subtracted from the address, and written back into the register Rn . The assembly language syntax for this mode is:

```
[Rn], #offset
```

The value to load or store can be a byte, halfword, word, or two words. Bytes and halfwords can either be signed or unsigned. See “[Address Alignment](#)”.

The table below shows the ranges of offset for immediate, pre-indexed and post-indexed forms.

Table 11-18. Offset Ranges

Instruction Type	Immediate Offset	Pre-indexed	Post-indexed
Word, halfword, signed halfword, byte, or signed byte	-255 to 4095	-255 to 255	-255 to 255
Two words	multiple of 4 in the range -1020 to 1020	multiple of 4 in the range -1020 to 1020	multiple of 4 in the range -1020 to 1020

Restrictions

For load instructions:

- Rt can be SP or PC for word loads only
- Rt must be different from $Rt2$ for two-word loads
- Rn must be different from Rt and $Rt2$ in the pre-indexed or post-indexed forms.

When Rt is PC in a word load instruction:

- Bit[0] of the loaded value must be 1 for correct execution
- A branch occurs to the address created by changing bit[0] of the loaded value to 0
- If the instruction is conditional, it must be the last instruction in the IT block.

For store instructions:

- Rt can be SP for word stores only
- Rt must not be PC
- Rn must not be PC
- Rn must be different from Rt and $Rt2$ in the pre-indexed or post-indexed forms.

Condition Flags

These instructions do not change the flags.

Examples

```

LDR    R8, [R10]           ; Loads R8 from the address in R10.
LDRNE  R2, [R5, #960]!    ; Loads (conditionally) R2 from a word
                           ; 960 bytes above the address in R5, and
                           ; increments R5 by 960.
STR    R2, [R9,#const-struct] ; const-struct is an expression evaluating
                           ; to a constant in the range 0-4095.
STRH   R3, [R4], #4       ; Store R3 as halfword data into address in
                           ; R4, then increment R4 by 4
LDRD   R8, R9, [R3, #0x20] ; Load R8 from a word 32 bytes above the
                           ; address in R3, and load R9 from a word 36
                           ; bytes above the address in R3
STRD   R0, R1, [R8], #-16  ; Store R0 to address in R8, and store R1 to
                           ; a word 4 bytes above the address in R8,
                           ; and then decrement R8 by 16.

```

11.6.4.3 LDR and STR, Register Offset

Load and Store with register offset.

Syntax

```
op{type}{cond} Rt, [Rn, Rm {, LSL #n}]
```

where:

op is one of:

LDR Load Register.

STR Store Register.

type is one of:

B unsigned byte, zero extend to 32 bits on loads.

SB signed byte, sign extend to 32 bits (LDR only).

H unsigned halfword, zero extend to 32 bits on loads.

SH signed halfword, sign extend to 32 bits (LDR only).

- omit, for word.

cond is an optional condition code, see [“Conditional Execution”](#) .

Rt is the register to load or store.

Rn is the register on which the memory address is based.

Rm is a register containing a value to be used as the offset.

LSL #n is an optional shift, with *n* in the range 0 to 3.

Operation

LDR instructions load a register with a value from memory.

STR instructions store a register value into memory.

The memory address to load from or store to is at an offset from the register *Rn*. The offset is specified by the register *Rm* and can be shifted left by up to 3 bits using LSL.

The value to load or store can be a byte, halfword, or word. For load instructions, bytes and halfwords can either be signed or unsigned. See “[Address Alignment](#)”.

Restrictions

In these instructions:

- *Rn* must not be PC
- *Rm* must not be SP and must not be PC
- *Rt* can be SP only for word loads and word stores
- *Rt* can be PC only for word loads.

When *Rt* is PC in a word load instruction:

- Bit[0] of the loaded value must be 1 for correct execution, and a branch occurs to this halfword-aligned address
- If the instruction is conditional, it must be the last instruction in the IT block.

Condition Flags

These instructions do not change the flags.

Examples

```
STR    R0, [R5, R1]           ; Store value of R0 into an address equal to
                                ; sum of R5 and R1
LDRSB  R0, [R5, R1, LSL #1] ; Read byte value from an address equal to
                                ; sum of R5 and two times R1, sign extended it
                                ; to a word value and put it in R0
STR    R0, [R1, R2, LSL #2] ; Stores R0 to an address equal to sum of R1
                                ; and four times R2
```

11.6.4.4 LDR and STR, unprivileged

Load and Store with unprivileged access.

Syntax

```
op{type}T{cond} Rt, [Rn {, #offset}] ; immediate offset
```

where:

op is one of:

- LDR Load Register.
- STR Store Register.

type is one of:

- B unsigned byte, zero extend to 32 bits on loads.
- SB signed byte, sign extend to 32 bits (LDR only).
- H unsigned halfword, zero extend to 32 bits on loads.
- SH signed halfword, sign extend to 32 bits (LDR only).
- omit, for word.

cond is an optional condition code, see “[Conditional Execution](#)” .

Rt is the register to load or store.

Rn is the register on which the memory address is based.

offset is an offset from *Rn* and can be 0 to 255.

If *offset* is omitted, the address is the value in *Rn*.

Operation

These load and store instructions perform the same function as the memory access instructions with immediate offset, see “[LDR and STR, Immediate Offset](#)” . The difference is that these instructions have only unprivileged access even when used in privileged software.

When used in unprivileged software, these instructions behave in exactly the same way as normal memory access instructions with immediate offset.

Restrictions

In these instructions:

- *Rn* must not be PC
- *Rt* must not be SP and must not be PC.

Condition Flags

These instructions do not change the flags.

Examples

```
STRBTEQ R4, [R7]      ; Conditionally store least significant byte in
                       ; R4 to an address in R7, with unprivileged access
LDRHT    R2, [R2, #8] ; Load halfword value from an address equal to
                       ; sum of R2 and 8 into R2, with unprivileged access
```

11.6.4.5 LDR, PC-relative

Load register from memory.

Syntax

```
LDR{type}{cond} Rt, label
LDRD{cond} Rt, Rt2, label      ; Load two words
```

where:

type is one of:

- B unsigned byte, zero extend to 32 bits.
- SB signed byte, sign extend to 32 bits.
- H unsigned halfword, zero extend to 32 bits.
- SH signed halfword, sign extend to 32 bits.
- omit, for word.

cond is an optional condition code, see “[Conditional Execution](#)” .

Rt is the register to load or store.

Rt2 is the second register to load or store.

label is a PC-relative expression. See [“PC-relative Expressions”](#).

Operation

LDR loads a register with a value from a PC-relative memory address. The memory address is specified by a *label* or by an offset from the PC.

The value to load or store can be a byte, halfword, or word. For load instructions, bytes and halfwords can either be signed or unsigned. See [“Address Alignment”](#).

label must be within a limited range of the current instruction. The table below shows the possible offsets between *label* and the PC.

Table 11-19. Offset Ranges

Instruction Type	Offset Range
Word, halfword, signed halfword, byte, signed byte	-4095 to 4095
Two words	-1020 to 1020

The user might have to use the *.W* suffix to get the maximum offset range. See [“Instruction Width Selection”](#).

Restrictions

In these instructions:

- *Rt* can be SP or PC only for word loads
- *Rt2* must not be SP and must not be PC
- *Rt* must be different from *Rt2*.

When *Rt* is PC in a word load instruction:

- bit[0] of the loaded value must be 1 for correct execution, and a branch occurs to this halfword-aligned address
- if the instruction is conditional, it must be the last instruction in the IT block.

Condition Flags

These instructions do not change the flags.

Examples

```
LDR    R0, LookUpTable    ; Load R0 with a word of data from an address
                          ; labelled as LookUpTable
LDRSB  R7, localdata      ; Load a byte value from an address labelled
                          ; as localdata, sign extend it to a word
                          ; value, and put it in R7
```

11.6.4.6 LDM and STM

Load and Store Multiple registers.

Syntax

```
op{addr_mode}{cond} Rn{!}, reglist
```

where:

op is one of:

LDM Load Multiple registers.

STM Store Multiple registers.

addr_mode is any one of the following:

IA Increment address After each access. This is the default.

DB Decrement address Before each access.

cond is an optional condition code, see [“Conditional Execution”](#) .

Rn is the register on which the memory addresses are based.

! is an optional writeback suffix.

If ! is present, the final address, that is loaded from or stored to, is written back into *Rn*.

reglist is a list of one or more registers to be loaded or stored, enclosed in braces. It can contain register ranges. It must be comma separated if it contains more than one register or register range, see [“Examples”](#) .

LDM and LDMFD are synonyms for LDMIA. LDMFD refers to its use for popping data from Full Descending stacks.

LDMEA is a synonym for LDMDB, and refers to its use for popping data from Empty Ascending stacks.

STM and STMEA are synonyms for STMIA. STMEA refers to its use for pushing data onto Empty Ascending stacks.

STMFD is a synonym for STMDB, and refers to its use for pushing data onto Full Descending stacks

Operation

LDM instructions load the registers in *reglist* with word values from memory addresses based on *Rn*.

STM instructions store the word values in the registers in *reglist* to memory addresses based on *Rn*.

For LDM, LDMIA, LDMFD, STM, STMIA, and STMEA the memory addresses used for the accesses are at 4-byte intervals ranging from Rn to $Rn + 4 * (n-1)$, where n is the number of registers in *reglist*. The accesses happens in order of increasing register numbers, with the lowest numbered register using the lowest memory address and the highest number register using the highest memory address. If the writeback suffix is specified, the value of $Rn + 4 * (n-1)$ is written back to *Rn*.

For LDMDB, LDMEA, STMDB, and STMFD the memory addresses used for the accesses are at 4-byte intervals ranging from Rn to $Rn - 4 * (n-1)$, where n is the number of registers in *reglist*.

The accesses happen in order of decreasing register numbers, with the highest numbered register using the highest memory address and the lowest number register using the lowest memory address. If the writeback suffix is specified, the value of $Rn - 4 * (n-1)$ is written back to Rn .

The PUSH and POP instructions can be expressed in this form. See “[PUSH and POP](#)” for details.

Restrictions

In these instructions:

- Rn must not be PC
- *reglist* must not contain SP
- in any STM instruction, *reglist* must not contain PC
- in any LDM instruction, *reglist* must not contain PC if it contains LR
- *reglist* must not contain Rn if the writeback suffix is specified.

When PC is in *reglist* in an LDM instruction:

- bit[0] of the value loaded to the PC must be 1 for correct execution, and a branch occurs to this halfword-aligned address
- if the instruction is conditional, it must be the last instruction in the IT block.

Condition Flags

These instructions do not change the flags.

Examples

```
LDM    R8, {R0,R2,R9}      ; LDMIA is a synonym for LDM
STMDB  R1!, {R3-R6,R11,R12}
```

Incorrect examples

```
STM    R5!, {R5,R4,R9} ; Value stored for R5 is unpredictable
LDM    R2, {}          ; There must be at least one register in the list
```

11.6.4.7 PUSH and POP

Push registers onto, and pop registers off a full-descending stack.

Syntax

```
PUSH{cond} reglist
POP{cond} reglist
```

where:

- cond** is an optional condition code, see [“Conditional Execution”](#) .
- reglist** is a non-empty list of registers, enclosed in braces. It can contain register ranges. It must be comma separated if it contains more than one register or register range.

PUSH and POP are synonyms for STMDB and LDM (or LDMIA) with the memory addresses for the access based on SP, and with the final address for the access written back to the SP. PUSH and POP are the preferred mnemonics in these cases.

Operation

PUSH stores registers on the stack in order of decreasing the register numbers, with the highest numbered register using the highest memory address and the lowest numbered register using the lowest memory address.

POP loads registers from the stack in order of increasing register numbers, with the lowest numbered register using the lowest memory address and the highest numbered register using the highest memory address.

See [“LDM and STM”](#) for more information.

Restrictions

In these instructions:

- *reglist* must not contain SP
- for the PUSH instruction, *reglist* must not contain PC
- for the POP instruction, *reglist* must not contain PC if it contains LR.

When PC is in *reglist* in a POP instruction:

- bit[0] of the value loaded to the PC must be 1 for correct execution, and a branch occurs to this halfword-aligned address
- if the instruction is conditional, it must be the last instruction in the IT block.

Condition Flags

These instructions do not change the flags.

Examples

```
PUSH    {R0, R4-R7}
PUSH    {R2, LR}
POP     {R0, R10, PC}
```

11.6.4.8 LDREX and STREX

Load and Store Register Exclusive.

Syntax

```
LDREX{cond} Rt, [Rn {, #offset}]
STREX{cond} Rd, Rt, [Rn {, #offset}]
LDREXB{cond} Rt, [Rn]
STREXB{cond} Rd, Rt, [Rn]
LDREXH{cond} Rt, [Rn]
STREXH{cond} Rd, Rt, [Rn]
```

where:

cond is an optional condition code, see “[Conditional Execution](#)” .

Rd is the destination register for the returned status.

Rt is the register to load or store.

Rn is the register on which the memory address is based.

offset is an optional offset applied to the value in *Rn*.
If *offset* is omitted, the address is the value in *Rn*.

Operation

LDREX, LDREXB, and LDREXH load a word, byte, and halfword respectively from a memory address.

STREX, STREXB, and STREXH attempt to store a word, byte, and halfword respectively to a memory address. The address used in any Store-Exclusive instruction must be the same as the address in the most recently executed Load-exclusive instruction. The value stored by the Store-Exclusive instruction must also have the same data size as the value loaded by the preceding Load-exclusive instruction. This means software must always use a Load-exclusive instruction and a matching Store-Exclusive instruction to perform a synchronization operation, see “[Synchronization Primitives](#)” .

If an Store-Exclusive instruction performs the store, it writes 0 to its destination register. If it does not perform the store, it writes 1 to its destination register. If the Store-Exclusive instruction writes 0 to the destination register, it is guaranteed that no other process in the system has accessed the memory location between the Load-exclusive and Store-Exclusive instructions.

For reasons of performance, keep the number of instructions between corresponding Load-Exclusive and Store-Exclusive instruction to a minimum.

The result of executing a Store-Exclusive instruction to an address that is different from that used in the preceding Load-Exclusive instruction is unpredictable.

Restrictions

In these instructions:

- do not use PC
- do not use SP for *Rd* and *Rt*
- for STREX, *Rd* must be different from both *Rt* and *Rn*
- the value of *offset* must be a multiple of four in the range 0-1020.

Condition Flags

These instructions do not change the flags.

Examples

```

MOV      R1, #0x1           ; Initialize the 'lock taken' value
try
LDREX   R0, [LockAddr]     ; Load the lock value
CMP     R0, #0             ; Is the lock free?
ITT     EQ                 ; IT instruction for STREXEQ and CMPEQ
STREXEQ R0, R1, [LockAddr] ; Try and claim the lock
CMPEQ   R0, #0             ; Did this succeed?
BNE     try                ; No - try again
.....                     ; Yes - we have the lock

```

11.6.4.9 CLREX

Clear Exclusive.

Syntax

```
CLREX{cond}
```

where:

cond is an optional condition code, see [“Conditional Execution”](#) .

Operation

Use CLREX to make the next STREX, STREXB, or STREXH instruction write 1 to its destination register and fail to perform the store. It is useful in exception handler code to force the failure of the store exclusive if the exception occurs between a load exclusive instruction and the matching store exclusive instruction in a synchronization operation.

See [“Synchronization Primitives”](#) for more information.

Condition Flags

These instructions do not change the flags.

Examples

```
CLREX
```

11.6.5 General Data Processing Instructions

The table below shows the data processing instructions:

Table 11-20. Data Processing Instructions

Mnemonic	Description
ADC	Add with Carry
ADD	Add
ADDW	Add
AND	Logical AND
ASR	Arithmetic Shift Right
BIC	Bit Clear
CLZ	Count leading zeros
CMN	Compare Negative
CMP	Compare
EOR	Exclusive OR
LSL	Logical Shift Left
LSR	Logical Shift Right
MOV	Move
MOVT	Move Top
MOVW	Move 16-bit constant
MVN	Move NOT
ORN	Logical OR NOT
ORR	Logical OR
RBIT	Reverse Bits
REV	Reverse byte order in a word
REV16	Reverse byte order in each halfword
REVSH	Reverse byte order in bottom halfword and sign extend
ROR	Rotate Right
RRX	Rotate Right with Extend
RSB	Reverse Subtract
SADD16	Signed Add 16
SADD8	Signed Add 8
SASX	Signed Add and Subtract with Exchange
SSAX	Signed Subtract and Add with Exchange
SBC	Subtract with Carry
SHADD16	Signed Halving Add 16
SHADD8	Signed Halving Add 8
SHASX	Signed Halving Add and Subtract with Exchange
SHSAX	Signed Halving Subtract and Add with Exchange

Table 11-20. Data Processing Instructions (Continued)

Mnemonic	Description
SHSUB16	Signed Halving Subtract 16
SHSUB8	Signed Halving Subtract 8
SSUB16	Signed Subtract 16
SSUB8	Signed Subtract 8
SUB	Subtract
SUBW	Subtract
TEQ	Test Equivalence
TST	Test
UADD16	Unsigned Add 16
UADD8	Unsigned Add 8
UASX	Unsigned Add and Subtract with Exchange
USAX	Unsigned Subtract and Add with Exchange
UHADD16	Unsigned Halving Add 16
UHADD8	Unsigned Halving Add 8
UHASX	Unsigned Halving Add and Subtract with Exchange
UHSAX	Unsigned Halving Subtract and Add with Exchange
UHSUB16	Unsigned Halving Subtract 16
UHSUB8	Unsigned Halving Subtract 8
USAD8	Unsigned Sum of Absolute Differences
USADA8	Unsigned Sum of Absolute Differences and Accumulate
USUB16	Unsigned Subtract 16
USUB8	Unsigned Subtract 8

11.6.5.1 ADD, ADC, SUB, SBC, and RSB

Add, Add with carry, Subtract, Subtract with carry, and Reverse Subtract.

Syntax

```

op{S}{cond} {Rd,} Rn, Operand2
op{cond} {Rd,} Rn, #imm12           ; ADD and SUB only

```

where:

op	is one of: ADD Add. ADC Add with Carry. SUB Subtract. SBC Subtract with Carry. RSB Reverse Subtract.
S	is an optional suffix. If S is specified, the condition code flags are updated on the result of the operation, see “Conditional Execution” .
cond	is an optional condition code, see “Conditional Execution” .
Rd	is the destination register. If Rd is omitted, the destination register is Rn.
Rn	is the register holding the first operand.
Operand2	is a flexible second operand. See “Flexible Second Operand” for details of the options.
imm12	is any value in the range 0-4095.

Operation

The ADD instruction adds the value of *Operand2* or *imm12* to the value in *Rn*.

The ADC instruction adds the values in *Rn* and *Operand2*, together with the carry flag.

The SUB instruction subtracts the value of *Operand2* or *imm12* from the value in *Rn*.

The SBC instruction subtracts the value of *Operand2* from the value in *Rn*. If the carry flag is clear, the result is reduced by one.

The RSB instruction subtracts the value in *Rn* from the value of *Operand2*. This is useful because of the wide range of options for *Operand2*.

Use ADC and SBC to synthesize multiword arithmetic, see [Multiword arithmetic examples on](#).

See also [“ADR”](#).

Note: ADDW is equivalent to the ADD syntax that uses the *imm12* operand. SUBW is equivalent to the SUB syntax that uses the *imm12* operand.

Restrictions

In these instructions:

- *Operand2* must not be SP and must not be PC
- *Rd* can be SP only in ADD and SUB, and only with the additional restrictions:
 - *Rn* must also be SP
 - any shift in *Operand2* must be limited to a maximum of 3 bits using LSL
- *Rn* can be SP only in ADD and SUB
- *Rd* can be PC only in the ADD{cond} PC, PC, Rm instruction where:
 - the user must not specify the S suffix
 - *Rm* must not be PC and must not be SP

- if the instruction is conditional, it must be the last instruction in the IT block
- with the exception of the `ADD{cond} PC, PC, Rm` instruction, *Rn* can be PC only in ADD and SUB, and only with the additional restrictions:
 - the user must not specify the S suffix
 - the second operand must be a constant in the range 0 to 4095.
 - Note: When using the PC for an addition or a subtraction, bits[1:0] of the PC are rounded to 0b00 before performing the calculation, making the base address for the calculation word-aligned.
 - Note: To generate the address of an instruction, the constant based on the value of the PC must be adjusted. ARM recommends to use the ADR instruction instead of ADD or SUB with *Rn* equal to the PC, because the assembler automatically calculates the correct constant for the ADR instruction.

When *Rd* is PC in the `ADD{cond} PC, PC, Rm` instruction:

- bit[0] of the value written to the PC is ignored
- a branch occurs to the address created by forcing bit[0] of that value to 0.

Condition Flags

If S is specified, these instructions update the N, Z, C and V flags according to the result.

Examples

```

ADD    R2, R1, R3
SUBS   R8, R6, #240      ; Sets the flags on the result
RSB    R4, R4, #1280     ; Subtracts contents of R4 from 1280
ADCHI  R11, R0, R3      ; Only executed if C flag set and Z
                               ; flag clear.

```

Multiword arithmetic examples

The example below shows two instructions that add a 64-bit integer contained in R2 and R3 to another 64-bit integer contained in R0 and R1, and place the result in R4 and R5.

64-bit addition example:

```

ADDS   R4, R0, R2      ; add the least significant words
ADC    R5, R1, R3      ; add the most significant words with carry

```

Multiword values do not have to use consecutive registers. The example below shows instructions that subtract a 96-bit integer contained in R9, R1, and R11 from another contained in R6, R2, and R8. The example stores the result in R6, R9, and R2.

96-bit subtraction example:

```

SUBS   R6, R6, R9      ; subtract the least significant words
SBCS   R9, R2, R1      ; subtract the middle words with carry
SBC    R2, R8, R11     ; subtract the most significant words with carry

```

11.6.5.2 AND, ORR, EOR, BIC, and ORN

Logical AND, OR, Exclusive OR, Bit Clear, and OR NOT.

Syntax

$op\{S\}\{cond\} \{Rd,\} Rn, Operand2$

where:

op	is one of: AND logical AND. ORR logical OR, or bit set. EOR logical Exclusive OR. BIC logical AND NOT, or bit clear. ORN logical OR NOT.
S	is an optional suffix. If S is specified, the condition code flags are updated on the result of the operation, see “Conditional Execution” .
cond	is an optional condition code, see “Conditional Execution” .
Rd	is the destination register.
Rn	is the register holding the first operand.
Operand2	is a flexible second operand. See “Flexible Second Operand” for details of the options.

Operation

The AND, EOR, and ORR instructions perform bitwise AND, Exclusive OR, and OR operations on the values in *Rn* and *Operand2*.

The BIC instruction performs an AND operation on the bits in *Rn* with the complements of the corresponding bits in the value of *Operand2*.

The ORN instruction performs an OR operation on the bits in *Rn* with the complements of the corresponding bits in the value of *Operand2*.

Restrictions

Do not use SP and do not use PC.

Condition Flags

If S is specified, these instructions:

- update the N and Z flags according to the result
- can update the C flag during the calculation of *Operand2*, see [“Flexible Second Operand”](#)
- do not affect the V flag.

Examples

```

AND      R9, R2, #0xFF00
ORREQ    R2, R0, R5
ANDS     R9, R8, #0x19
EORS     R7, R11, #0x18181818
BIC      R0, R1, #0xab
ORN      R7, R11, R14, ROR #4
ORNS     R7, R11, R14, ASR #32
    
```

11.6.5.3 ASR, LSL, LSR, ROR, and RRX

Arithmetic Shift Right, Logical Shift Left, Logical Shift Right, Rotate Right, and Rotate Right with Extend.

Syntax

```

op{S}{cond} Rd, Rm, Rs
op{S}{cond} Rd, Rm, #n
RRX{S}{cond} Rd, Rm

```

where:

op	is one of: ASR Arithmetic Shift Right. LSL Logical Shift Left. LSR Logical Shift Right. ROR Rotate Right.
S	is an optional suffix. If S is specified, the condition code flags are updated on the result of the operation, see “Conditional Execution” .
Rd	is the destination register.
Rm	is the register holding the value to be shifted.
Rs	is the register holding the shift length to apply to the value in Rm. Only the least significant byte is used and can be in the range 0 to 255.
n	is the shift length. The range of shift length depends on the instruction: ASR shift length from 1 to 32 LSL shift length from 0 to 31 LSR shift length from 1 to 32 ROR shift length from 1 to 31.

MOVS Rd, Rm is the preferred syntax for LSLs Rd, Rm, #0.

Operation

ASR, LSL, LSR, and ROR move the bits in the register Rm to the left or right by the number of places specified by constant n or register Rs.

RRX moves the bits in register Rm to the right by 1.

In all these instructions, the result is written to Rd, but the value in register Rm remains unchanged. For details on what result is generated by the different instructions, see [“Shift Operations”](#).

Restrictions

Do not use SP and do not use PC.

Condition Flags

If S is specified:

- these instructions update the N and Z flags according to the result
- the C flag is updated to the last bit shifted out, except when the shift length is 0, see [“Shift Operations”](#).

Examples

```
ASR    R7, R8, #9 ; Arithmetic shift right by 9 bits
LSLS   R1, R2, #3 ; Logical shift left by 3 bits with flag update
LSR    R4, R5, #6 ; Logical shift right by 6 bits
ROR    R4, R5, R6 ; Rotate right by the value in the bottom byte of R6
RRX    R4, R5     ; Rotate right with extend.
```

11.6.5.4 CLZ

Count Leading Zeros.

Syntax

```
CLZ{cond} Rd, Rm
```

where:

cond is an optional condition code, see [“Conditional Execution”](#).
Rd is the destination register.
Rm is the operand register.

Operation

The CLZ instruction counts the number of leading zeros in the value in *Rm* and returns the result in *Rd*. The result value is 32 if no bits are set and zero if bit[31] is set.

Restrictions

Do not use SP and do not use PC.

Condition Flags

This instruction does not change the flags.

Examples

```
CLZ    R4, R9
CLZNE  R2, R3
```

11.6.5.5 *CMP and CMN*

Compare and Compare Negative.

Syntax

```
CMP{cond} Rn, Operand2
CMN{cond} Rn, Operand2
```

where:

cond is an optional condition code, see [“Conditional Execution”](#) .
 Rn is the register holding the first operand.
 Operand2 is a flexible second operand. See [“Flexible Second Operand”](#) for details of the options.

Operation

These instructions compare the value in a register with *Operand2*. They update the condition flags on the result, but do not write the result to a register.

The *CMP* instruction subtracts the value of *Operand2* from the value in *Rn*. This is the same as a *SUBS* instruction, except that the result is discarded.

The *CMN* instruction adds the value of *Operand2* to the value in *Rn*. This is the same as an *ADDS* instruction, except that the result is discarded.

Restrictions

In these instructions:

- do not use PC
- *Operand2* must not be SP.

Condition Flags

These instructions update the N, Z, C and V flags according to the result.

Examples

```
CMP    R2, R9
CMN    R0, #6400
CMPGT  SP, R7, LSL #2
```

11.6.5.6 MOV and MVN

Move and Move NOT.

Syntax

`MOV{S}{cond} Rd, Operand2`

`MOV{cond} Rd, #imm16`

`MVN{S}{cond} Rd, Operand2`

where:

S	is an optional suffix. If S is specified, the condition code flags are updated on the result of the operation, see “Conditional Execution” .
cond	is an optional condition code, see “Conditional Execution” .
Rd	is the destination register.
Operand2	is a flexible second operand. See “Flexible Second Operand” for details of the options.
imm16	is any value in the range 0-65535.

Operation

The MOV instruction copies the value of *Operand2* into *Rd*.

When *Operand2* in a MOV instruction is a register with a shift other than LSL #0, the preferred syntax is the corresponding shift instruction:

- `ASR{S}{cond} Rd, Rm, #n` is the preferred syntax for `MOV{S}{cond} Rd, Rm, ASR #n`
- `LSL{S}{cond} Rd, Rm, #n` is the preferred syntax for `MOV{S}{cond} Rd, Rm, LSL #n` if $n \neq 0$
- `LSR{S}{cond} Rd, Rm, #n` is the preferred syntax for `MOV{S}{cond} Rd, Rm, LSR #n`
- `ROR{S}{cond} Rd, Rm, #n` is the preferred syntax for `MOV{S}{cond} Rd, Rm, ROR #n`
- `RRX{S}{cond} Rd, Rm` is the preferred syntax for `MOV{S}{cond} Rd, Rm, RRX`.

Also, the MOV instruction permits additional forms of *Operand2* as synonyms for shift instructions:

- `MOV{S}{cond} Rd, Rm, ASR Rs` is a synonym for `ASR{S}{cond} Rd, Rm, Rs`
- `MOV{S}{cond} Rd, Rm, LSL Rs` is a synonym for `LSL{S}{cond} Rd, Rm, Rs`
- `MOV{S}{cond} Rd, Rm, LSR Rs` is a synonym for `LSR{S}{cond} Rd, Rm, Rs`
- `MOV{S}{cond} Rd, Rm, ROR Rs` is a synonym for `ROR{S}{cond} Rd, Rm, Rs`

See [“ASR, LSL, LSR, ROR, and RRX”](#).

The MVN instruction takes the value of *Operand2*, performs a bitwise logical NOT operation on the value, and places the result into *Rd*.

The MOVW instruction provides the same function as MOV, but is restricted to using the *imm16* operand.

Restrictions

SP and PC only can be used in the MOV instruction, with the following restrictions:

- the second operand must be a register without shift
- the S suffix must not be specified.

When *Rd* is PC in a MOV instruction:

- bit[0] of the value written to the PC is ignored
- a branch occurs to the address created by forcing bit[0] of that value to 0.

Though it is possible to use MOV as a branch instruction, ARM strongly recommends the use of a BX or BLX instruction to branch for software portability to the ARM instruction set.

Condition Flags

If S is specified, these instructions:

- update the N and Z flags according to the result
- can update the C flag during the calculation of *Operand2*, see [“Flexible Second Operand”](#)
- do not affect the V flag.

Example

```

MOVSN R11, #0x000B ; Write value of 0x000B to R11, flags get updated
MOV   R1, #0xFA05  ; Write value of 0xFA05 to R1, flags are not updated
MOVSN R10, R12     ; Write value in R12 to R10, flags get updated
MOV   R3, #23      ; Write value of 23 to R3
MOV   R8, SP       ; Write value of stack pointer to R8
MVNS  R2, #0xF     ; Write value of 0xFFFFFFF0 (bitwise inverse of 0xF)
                        ; to the R2 and update flags.

```

11.6.5.7 MOVN

Move Top.

Syntax

```
MOVN{cond} Rd, #imm16
```

where:

cond is an optional condition code, see [“Conditional Execution”](#).

Rd is the destination register.

imm16 is a 16-bit immediate constant.

Operation

MOVN writes a 16-bit immediate value, *imm16*, to the top halfword, *Rd*[31:16], of its destination register. The write does not affect *Rd*[15:0].

The MOV, MOVN instruction pair enables to generate any 32-bit constant.

Restrictions

Rd must not be SP and must not be PC.

Condition Flags

This instruction does not change the flags.

Examples

```

MOVN  R3, #0xF123 ; Write 0xF123 to upper halfword of R3, lower halfword
                        ; and APSR are unchanged.

```

11.6.5.8 REV, REV16, REVSH, and RBIT

Reverse bytes and Reverse bits.

Syntax

```
op{cond} Rd, Rn
```

where:

op	is any of: REV Reverse byte order in a word. REV16 Reverse byte order in each halfword independently. REVSH Reverse byte order in the bottom halfword, and sign extend to 32 bits. RBIT Reverse the bit order in a 32-bit word.
cond	is an optional condition code, see "Conditional Execution" .
Rd	is the destination register.
Rn	is the register holding the operand.

Operation

Use these instructions to change endianness of data:

REV converts either:

- 32-bit big-endian data into little-endian data
- 32-bit little-endian data into big-endian data.

REV16 converts either:

- 16-bit big-endian data into little-endian data
- 16-bit little-endian data into big-endian data.

REVSH converts either:

- 16-bit signed big-endian data into 32-bit signed little-endian data
- 16-bit signed little-endian data into 32-bit signed big-endian data.

Restrictions

Do not use SP and do not use PC.

Condition Flags

These instructions do not change the flags.

Examples

```
REV    R3, R7 ; Reverse byte order of value in R7 and write it to R3
REV16  R0, R0 ; Reverse byte order of each 16-bit halfword in R0
REVSH  R0, R5 ; Reverse Signed Halfword
REVSHS R3, R7 ; Reverse with Higher or Same condition
RBIT   R7, R8 ; Reverse bit order of value in R8 and write the result
           ; to R7.
```

11.6.5.9 SADD16 and SADD8

Signed Add 16 and Signed Add 8

Syntax

`op{cond}{Rd,} Rn, Rm`

where:

op	is any of: SADD16 Performs two 16-bit signed integer additions. SADD8 Performs four 8-bit signed integer additions.
cond	is an optional condition code, see “Conditional Execution” .
Rd	is the destination register.
Rn	is the first register holding the operand.
Rm	is the second register holding the operand.

Operation

Use these instructions to perform a halfword or byte add in parallel:

The SADD16 instruction:

1. Adds each halfword from the first operand to the corresponding halfword of the second operand.
2. Writes the result in the corresponding halfwords of the destination register.

The SADD8 instruction:

1. Adds each byte of the first operand to the corresponding byte of the second operand.

Writes the result in the corresponding bytes of the destination register.

Restrictions

Do not use SP and do not use PC.

Condition Flags

These instructions do not change the flags.

Examples

```
SADD16 R1, R0      ; Adds the halfwords in R0 to the corresponding
                   ; halfwords of R1 and writes to corresponding halfword
                   ; of R1.
SADD8  R4, R0, R5  ; Adds bytes of R0 to the corresponding byte in R5 and
                   ; writes to the corresponding byte in R4.
```

11.6.5.10 SHADD16 and SHADD8

Signed Halving Add 16 and Signed Halving Add 8

Syntax

```
op{cond}{Rd,} Rn, Rm
```

where:

op	is any of: SHADD16 Signed Halving Add 16 SHADD8 Signed Halving Add 8
cond	is an optional condition code, see “Conditional Execution” .
Rd	is the destination register.
Rn	is the first operand register.
Rm	is the second operand register.

Operation

Use these instructions to add 16-bit and 8-bit data and then to halve the result before writing the result to the destination register:

The SHADD16 instruction:

1. Adds each halfword from the first operand to the corresponding halfword of the second operand.
2. Shuffles the result by one bit to the right, halving the data.
3. Writes the halfword results in the destination register.

The SHADD8 instruction:

1. Adds each byte of the first operand to the corresponding byte of the second operand.
2. Shuffles the result by one bit to the right, halving the data.
3. Writes the byte results in the destination register.

Restrictions

Do not use SP and do not use PC.

Condition Flags

These instructions do not change the flags.

Examples

```
SHADD16 R1, R0 ; Adds halfwords in R0 to corresponding halfword of R1 and
                ; writes halved result to corresponding halfword in R1
SHADD8 R4, R0, R5; Adds bytes of R0 to corresponding byte in R5 and
                ; writes halved result to corresponding byte in R4.
```

11.6.5.11 SHASX and SHSAX

Signed Halving Add and Subtract with Exchange and Signed Halving Subtract and Add with Exchange.

Syntax

`op{cond} {Rd}, Rn, Rm`

where:

op is any of:
 SHASX Add and Subtract with Exchange and Halving.
 SHSAX Subtract and Add with Exchange and Halving.

cond is an optional condition code, see ["Conditional Execution"](#).

Rd is the destination register.

Rn, Rm are registers holding the first and second operands.

Operation

The SHASX instruction:

1. Adds the top halfword of the first operand with the bottom halfword of the second operand.
2. Writes the halfword result of the addition to the top halfword of the destination register, shifted by one bit to the right causing a divide by two, or halving.
3. Subtracts the top halfword of the second operand from the bottom highword of the first operand.
4. Writes the halfword result of the division in the bottom halfword of the destination register, shifted by one bit to the right causing a divide by two, or halving.

The SHSAX instruction:

1. Subtracts the bottom halfword of the second operand from the top highword of the first operand.
2. Writes the halfword result of the addition to the bottom halfword of the destination register, shifted by one bit to the right causing a divide by two, or halving.
3. Adds the bottom halfword of the first operand with the top halfword of the second operand.
4. Writes the halfword result of the division in the top halfword of the destination register, shifted by one bit to the right causing a divide by two, or halving.

Restrictions

Do not use SP and do not use PC.

Condition Flags

These instructions do not affect the condition code flags.

Examples

```

SHASX    R7, R4, R2    ; Adds top halfword of R4 to bottom halfword of R2
                                ; and writes halved result to top halfword of R7
                                ; Subtracts top halfword of R2 from bottom halfword of
                                ; R4 and writes halved result to bottom halfword of R7
SHSAX    R0, R3, R5    ; Subtracts bottom halfword of R5 from top halfword
                                ; of R3 and writes halved result to top halfword of R0
  
```



```
; Adds top halfword of R5 to bottom halfword of R3 and  
; writes halved result to bottom halfword of R0.
```

11.6.5.12 SHSUB16 and SHSUB8

Signed Halving Subtract 16 and Signed Halving Subtract 8

Syntax

```
op{cond}{Rd,} Rn, Rm
```

where:

op	is any of: SHSUB16 Signed Halving Subtract 16 SHSUB8 Signed Halving Subtract 8
cond	is an optional condition code, see “Conditional Execution” .
Rd	is the destination register.
Rn	is the first operand register.
Rm	is the second operand register

Operation

Use these instructions to add 16-bit and 8-bit data and then to halve the result before writing the result to the destination register:

The SHSUB16 instruction:

1. Subtracts each halfword of the second operand from the corresponding halfwords of the first operand.
2. Shuffles the result by one bit to the right, halving the data.
3. Writes the halved halfword results in the destination register.

The SHSUB8 instruction:

1. Subtracts each byte of the second operand from the corresponding byte of the first operand,
2. Shuffles the result by one bit to the right, halving the data,
3. Writes the corresponding signed byte results in the destination register.

Restrictions

Do not use SP and do not use PC.

Condition Flags

These instructions do not change the flags.

Examples

```
SHSUB16 R1, R0 ; Subtracts halfwords in R0 from corresponding halfword  
; of R1 and writes to corresponding halfword of R1  
SHSUB8 R4, R0, R5 ; Subtracts bytes of R0 from corresponding byte in R5,  
; and writes to corresponding byte in R4.
```

11.6.5.13 SSUB16 and SSUB8

Signed Subtract 16 and Signed Subtract 8

Syntax

$op\{cond\}\{Rd,\} Rn, Rm$

where:

op	is any of: SSUB16 Performs two 16-bit signed integer subtractions. SSUB8 Performs four 8-bit signed integer subtractions.
cond	is an optional condition code, see “Conditional Execution” .
Rd	is the destination register.
Rn	is the first operand register.
Rm	is the second operand register.

Operation

Use these instructions to change endianness of data:

The SSUB16 instruction:

1. Subtracts each halfword from the second operand from the corresponding halfword of the first operand
2. Writes the difference result of two signed halfwords in the corresponding halfword of the destination register.

The SSUB8 instruction:

1. Subtracts each byte of the second operand from the corresponding byte of the first operand
2. Writes the difference result of four signed bytes in the corresponding byte of the destination register.

Restrictions

Do not use SP and do not use PC.

Condition Flags

These instructions do not change the flags.

Examples

```
SSUB16 R1, R0      ; Subtracts halfwords in R0 from corresponding halfword
                  ; of R1 and writes to corresponding halfword of R1
SSUB8  R4, R0, R5  ; Subtracts bytes of R5 from corresponding byte in
                  ; R0, and writes to corresponding byte of R4.
```

11.6.5.14 SASX and SSAX

Signed Add and Subtract with Exchange and Signed Subtract and Add with Exchange.

Syntax

```
op{cond} {Rd}, Rm, Rn
```

where:

op	is any of: SASX Signed Add and Subtract with Exchange. SSAX Signed Subtract and Add with Exchange.
cond	is an optional condition code, see “Conditional Execution” .
Rd	is the destination register.
Rn, Rm	are registers holding the first and second operands.

Operation

The SASX instruction:

1. Adds the signed top halfword of the first operand with the signed bottom halfword of the second operand.
2. Writes the signed result of the addition to the top halfword of the destination register.
3. Subtracts the signed bottom halfword of the second operand from the top signed highword of the first operand.
4. Writes the signed result of the subtraction to the bottom halfword of the destination register.

The SSAX instruction:

1. Subtracts the signed bottom halfword of the second operand from the top signed highword of the first operand.
2. Writes the signed result of the addition to the bottom halfword of the destination register.
3. Adds the signed top halfword of the first operand with the signed bottom halfword of the second operand.
4. Writes the signed result of the subtraction to the top halfword of the destination register.

Restrictions

Do not use SP and do not use PC.

Condition Flags

These instructions do not affect the condition code flags.

Examples

```
SASX  R0, R4, R5 ; Adds top halfword of R4 to bottom halfword of R5 and
                ; writes to top halfword of R0
                ; Subtracts bottom halfword of R5 from top halfword of
                ; R4 and writes to bottom halfword of R0
SSAX  R7, R3, R2 ; Subtracts top halfword of R2 from bottom halfword of
                ; R3 and writes to bottom halfword of R7
                ; Adds top halfword of R3 with bottom halfword of R2 and
                ; writes to top halfword of R7.
```

11.6.5.15 TST and TEQ

Test bits and Test Equivalence.

Syntax

```
TST{cond} Rn, Operand2
TEQ{cond} Rn, Operand2
```

where:

cond is an optional condition code, see [“Conditional Execution”](#).
Rn is the register holding the first operand.
Operand2 is a flexible second operand. See [“Flexible Second Operand”](#) for details of the options.

Operation

These instructions test the value in a register against *Operand2*. They update the condition flags based on the result, but do not write the result to a register.

The TST instruction performs a bitwise AND operation on the value in *Rn* and the value of *Operand2*. This is the same as the ANDS instruction, except that it discards the result.

To test whether a bit of *Rn* is 0 or 1, use the TST instruction with an *Operand2* constant that has that bit set to 1 and all other bits cleared to 0.

The TEQ instruction performs a bitwise Exclusive OR operation on the value in *Rn* and the value of *Operand2*. This is the same as the EORS instruction, except that it discards the result.

Use the TEQ instruction to test if two values are equal without affecting the V or C flags.

TEQ is also useful for testing the sign of a value. After the comparison, the N flag is the logical Exclusive OR of the sign bits of the two operands.

Restrictions

Do not use SP and do not use PC.

Condition Flags

These instructions:

- update the N and Z flags according to the result
- can update the C flag during the calculation of *Operand2*, see [“Flexible Second Operand”](#)
- do not affect the V flag.

Examples

```
TST      R0, #0x3F8 ; Perform bitwise AND of R0 value to 0x3F8,
                  ; APSR is updated but result is discarded
TEQEQ    R10, R9   ; Conditionally test if value in R10 is equal to
                  ; value in R9, APSR is updated but result is
                  ; discarded.
```

11.6.5.16 UADD16 and UADD8

Unsigned Add 16 and Unsigned Add 8

Syntax

```
op{cond}{Rd,} Rn, Rm
```

where:

op	is any of: UADD16 Performs two 16-bit unsigned integer additions. UADD8 Performs four 8-bit unsigned integer additions.
cond	is an optional condition code, see “Conditional Execution” .
Rd	is the destination register.
Rn	is the first register holding the operand.
Rm	is the second register holding the operand.

Operation

Use these instructions to add 16- and 8-bit unsigned data:

The UADD16 instruction:

1. adds each halfword from the first operand to the corresponding halfword of the second operand.
2. writes the unsigned result in the corresponding halfwords of the destination register.

The UADD8 instruction:

1. adds each byte of the first operand to the corresponding byte of the second operand.
2. writes the unsigned result in the corresponding byte of the destination register.

Restrictions

Do not use SP and do not use PC.

Condition Flags

These instructions do not change the flags.

Examples

```
UADD16 R1, R0 ; Adds halfwords in R0 to corresponding halfword of R1,
              ; writes to corresponding halfword of R1
UADD8 R4, R0, R5 ; Adds bytes of R0 to corresponding byte in R5 and writes
                 ; to corresponding byte in R4.
```

11.6.5.17 UASX and USAX

Add and Subtract with Exchange and Subtract and Add with Exchange.

Syntax

```
op{cond} {Rd}, Rn, Rm
```

where:

op	is one of: UASX Add and Subtract with Exchange. USAX Subtract and Add with Exchange.
cond	is an optional condition code, see “Conditional Execution” .
Rd	is the destination register.
Rn, Rm	are registers holding the first and second operands.

Operation

The UASX instruction:

1. Subtracts the top halfword of the second operand from the bottom halfword of the first operand.
2. Writes the unsigned result from the subtraction to the bottom halfword of the destination register.
3. Adds the top halfword of the first operand with the bottom halfword of the second operand.
4. Writes the unsigned result of the addition to the top halfword of the destination register.

The USAX instruction:

1. Adds the bottom halfword of the first operand with the top halfword of the second operand.
2. Writes the unsigned result of the addition to the bottom halfword of the destination register.
3. Subtracts the bottom halfword of the second operand from the top halfword of the first operand.
4. Writes the unsigned result from the subtraction to the top halfword of the destination register.

Restrictions

Do not use SP and do not use PC.

Condition Flags

These instructions do not affect the condition code flags.

Examples

```
UASX R0, R4, R5 ; Adds top halfword of R4 to bottom halfword of R5 and
                ; writes to top halfword of R0
                ; Subtracts bottom halfword of R5 from top halfword of R0
                ; and writes to bottom halfword of R0
USAX R7, R3, R2 ; Subtracts top halfword of R2 from bottom halfword of R3
                ; and writes to bottom halfword of R7
                ; Adds top halfword of R3 to bottom halfword of R2 and
                ; writes to top halfword of R7.
```

11.6.5.18 UHADD16 and UHADD8

Unsigned Halving Add 16 and Unsigned Halving Add 8

Syntax

```
op{cond}{Rd}, Rn, Rm
```

where:

op	is any of: UHADD16 Unsigned Halving Add 16. UHADD8 Unsigned Halving Add 8.
cond	is an optional condition code, see “Conditional Execution” .
Rd	is the destination register.
Rn	is the register holding the first operand.
Rm	is the register holding the second operand.

Operation

Use these instructions to add 16- and 8-bit data and then to halve the result before writing the result to the destination register:

The UHADD16 instruction:

1. Adds each halfword from the first operand to the corresponding halfword of the second operand.
2. Shuffles the halfword result by one bit to the right, halving the data.
3. Writes the unsigned results to the corresponding halfword in the destination register.

The UHADD8 instruction:

1. Adds each byte of the first operand to the corresponding byte of the second operand.
2. Shuffles the byte result by one bit to the right, halving the data.
3. Writes the unsigned results in the corresponding byte in the destination register.

Restrictions

Do not use SP and do not use PC.

Condition Flags

These instructions do not change the flags.

Examples

```
UHADD16 R7, R3 ; Adds halfwords in R7 to corresponding halfword of R3
                ; and writes halved result to corresponding halfword in R7
UHADD8 R4, R0, R5 ; Adds bytes of R0 to corresponding byte in R5 and writes
                  ; halved result to corresponding byte in R4.
```

11.6.5.19 UHASX and UHSAX

Unsigned Halving Add and Subtract with Exchange and Unsigned Halving Subtract and Add with Exchange.

Syntax

```
op{cond} {Rd}, Rn, Rm
```

where:

op	is one of: UHASX Add and Subtract with Exchange and Halving. UHSAX Subtract and Add with Exchange and Halving.
cond	is an optional condition code, see “Conditional Execution” .
Rd	is the destination register.
Rn, Rm	are registers holding the first and second operands.

Operation

The UHASX instruction:

1. Adds the top halfword of the first operand with the bottom halfword of the second operand.
2. Shifts the result by one bit to the right causing a divide by two, or halving.
3. Writes the halfword result of the addition to the top halfword of the destination register.
4. Subtracts the top halfword of the second operand from the bottom highword of the first operand.
5. Shifts the result by one bit to the right causing a divide by two, or halving.
6. Writes the halfword result of the division in the bottom halfword of the destination register.

The UHSAX instruction:

1. Subtracts the bottom halfword of the second operand from the top highword of the first operand.
2. Shifts the result by one bit to the right causing a divide by two, or halving.
3. Writes the halfword result of the subtraction in the top halfword of the destination register.
4. Adds the bottom halfword of the first operand with the top halfword of the second operand.
5. Shifts the result by one bit to the right causing a divide by two, or halving.
6. Writes the halfword result of the addition to the bottom halfword of the destination register.

Restrictions

Do not use SP and do not use PC.

Condition Flags

These instructions do not affect the condition code flags.

Examples

```

UHASX    R7, R4, R2    ; Adds top halfword of R4 with bottom halfword of R2
                                ; and writes halved result to top halfword of R7
                                ; Subtracts top halfword of R2 from bottom halfword of
                                ; R7 and writes halved result to bottom halfword of R7
UHSAX    R0, R3, R5    ; Subtracts bottom halfword of R5 from top halfword of
                                ; R3 and writes halved result to top halfword of R0
                                ; Adds top halfword of R5 to bottom halfword of R3 and
                                ; writes halved result to bottom halfword of R0.

```

11.6.5.20 UHSUB16 and UHSUB8

Unsigned Halving Subtract 16 and Unsigned Halving Subtract 8

Syntax

```
op{cond}{Rd,} Rn, Rm
```

where:

op	is any of: UHSUB16 Performs two unsigned 16-bit integer additions, halves the results, and writes the results to the destination register. UHSUB8 Performs four unsigned 8-bit integer additions, halves the results, and writes the results to the destination register.
cond	is an optional condition code, see “Conditional Execution” .
Rd	is the destination register.
Rn	is the first register holding the operand.
Rm	is the second register holding the operand.

Operation

Use these instructions to add 16-bit and 8-bit data and then to halve the result before writing the result to the destination register:

The UHSUB16 instruction:

1. Subtracts each halfword of the second operand from the corresponding halfword of the first operand.
2. Shuffles each halfword result to the right by one bit, halving the data.
3. Writes each unsigned halfword result to the corresponding halfwords in the destination register.

The UHSUB8 instruction:

1. Subtracts each byte of second operand from the corresponding byte of the first operand.
2. Shuffles each byte result by one bit to the right, halving the data.
3. Writes the unsigned byte results to the corresponding byte of the destination register.

Restrictions

Do not use SP and do not use PC.

Condition Flags

These instructions do not change the flags.

Examples

```
UHSUB16 R1, R0 ; Subtracts halfwords in R0 from corresponding halfword
                ; of R1 and writes halved result to corresponding
                ; halfword in R1
UHSUB8 R4, R0, R5 ; Subtracts bytes of R5 from corresponding byte in R0
                  ; and writes halved result to corresponding byte in R4.
```

11.6.5.21 SEL

Select Bytes. Selects each byte of its result from either its first operand or its second operand, according to the values of the GE flags.

Syntax

```
SEL{<c>}{<q>} {<Rd> , } <Rn> , <Rm>
```

where:

<c>, <q>	is a standard assembler syntax fields.
<Rd>	is the destination register.
<Rn>	is the first operand register.
<Rm>	is the second operand register.

Operation

The SEL instruction:

1. Reads the value of each bit of APSR.GE.
2. Depending on the value of APSR.GE, assigns the destination register the value of either the first or second operand register.

Restrictions

None.

Condition Flags

These instructions do not change the flags.

Examples

```
SADD16 R0, R1, R2    ; Set GE bits based on result
SEL R0, R0, R3      ; Select bytes from R0 or R3, based on GE.
```

11.6.5.22 USAD8

Unsigned Sum of Absolute Differences

Syntax

```
USAD8{cond}{Rd,} Rn, Rm
```

where:

cond is an optional condition code, see [“Conditional Execution”](#) .
Rd is the destination register.
Rn is the first operand register.
Rm is the second operand register.

Operation

The USAD8 instruction:

1. Subtracts each byte of the second operand register from the corresponding byte of the first operand register.
2. Adds the absolute values of the differences together.
3. Writes the result to the destination register.

Restrictions

Do not use SP and do not use PC.

Condition Flags

These instructions do not change the flags.

Examples

```
USAD8 R1, R4, R0 ; Subtracts each byte in R0 from corresponding byte of R4  
                ; adds the differences and writes to R1  
USAD8 R0, R5    ; Subtracts bytes of R5 from corresponding byte in R0,  
                ; adds the differences and writes to R0.
```

11.6.5.23 USADA8

Unsigned Sum of Absolute Differences and Accumulate

Syntax

```
USADA8{cond}{Rd,} Rn, Rm, Ra
```

where:

cond	is an optional condition code, see “Conditional Execution” .
Rd	is the destination register.
Rn	is the first operand register.
Rm	is the second operand register.
Ra	is the register that contains the accumulation value.

Operation

The USADA8 instruction:

1. Subtracts each byte of the second operand register from the corresponding byte of the first operand register.
2. Adds the unsigned absolute differences together.
3. Adds the accumulation value to the sum of the absolute differences.
4. Writes the result to the destination register.

Restrictions

Do not use SP and do not use PC.

Condition Flags

These instructions do not change the flags.

Examples

```
USADA8 R1, R0, R6      ; Subtracts bytes in R0 from corresponding halfword of
                       ; R1, adds differences, adds value of R6, writes to R1
USADA8 R4, R0, R5, R2 ; Subtracts bytes of R5 from corresponding byte in R0
                       ; adds differences, adds value of R2, writes to R4.
```

11.6.5.24 USUB16 and USUB8

Unsigned Subtract 16 and Unsigned Subtract 8

Syntax

```
op{cond}{Rd,} Rn, Rm
```

where:

op	is any of: USUB16 Unsigned Subtract 16. USUB8 Unsigned Subtract 8.
cond	is an optional condition code, see “Conditional Execution” .
Rd	is the destination register.
Rn	is the first operand register.
Rm	is the second operand register.

Operation

Use these instructions to subtract 16-bit and 8-bit data before writing the result to the destination register:

The USUB16 instruction:

1. Subtracts each halfword from the second operand register from the corresponding halfword of the first operand register.
2. Writes the unsigned result in the corresponding halfwords of the destination register.

The USUB8 instruction:

1. Subtracts each byte of the second operand register from the corresponding byte of the first operand register.
2. Writes the unsigned byte result in the corresponding byte of the destination register.

Restrictions

Do not use SP and do not use PC.

Condition Flags

These instructions do not change the flags.

Examples

```
USUB16 R1, R0 ; Subtracts halfwords in R0 from corresponding halfword of R1  
              ; writes to corresponding halfword in R1  
USUB8 R4, R0, R5  
       ; Subtracts bytes of R5 from corresponding byte in R0 and  
       ; writes to the corresponding byte in R4.
```

11.6.6 Multiply and Divide Instructions

The table below shows the multiply and divide instructions:

Table 11-21. Multiply and Divide Instructions

Mnemonic	Description
MLA	Multiply with Accumulate, 32-bit result
MLS	Multiply and Subtract, 32-bit result
MUL	Multiply, 32-bit result
SDIV	Signed Divide
SMLA[B,T]	Signed Multiply Accumulate (halfwords)
SMLAD, SMLADX	Signed Multiply Accumulate Dual
SMLAL	Signed Multiply with Accumulate (32x32+64), 64-bit result
SMLAL[B,T]	Signed Multiply Accumulate Long (halfwords)
SMLALD, SMLALDX	Signed Multiply Accumulate Long Dual
SMLAW[B T]	Signed Multiply Accumulate (word by halfword)
SMLS	Signed Multiply Subtract Dual
SMLS	Signed Multiply Subtract Long Dual
SMMLA	Signed Most Significant Word Multiply Accumulate
SMMLS, SMMLSR	Signed Most Significant Word Multiply Subtract
SMUAD, SMUADX	Signed Dual Multiply Add
SMUL[B,T]	Signed Multiply (word by halfword)
SMMUL, SMMULR	Signed Most Significant Word Multiply
SMULL	Signed Multiply (32x32), 64-bit result
SMULWB, SMULWT	Signed Multiply (word by halfword)
SMUSD, SMUSD	Signed Dual Multiply Subtract
UDIV	Unsigned Divide
UMAAL	Unsigned Multiply Accumulate Accumulate Long (32x32+32+32), 64-bit result
UMLAL	Unsigned Multiply with Accumulate (32x32+64), 64-bit result
UMULL	Unsigned Multiply (32x32), 64-bit result

11.6.6.1 MUL, MLA, and MLS

Multiply, Multiply with Accumulate, and Multiply with Subtract, using 32-bit operands, and producing a 32-bit result.

Syntax

```
MUL{S}{cond} {Rd,} Rn, Rm ; Multiply
MLA{cond} Rd, Rn, Rm, Ra ; Multiply with accumulate
MLS{cond} Rd, Rn, Rm, Ra ; Multiply with subtract
```

where:

cond is an optional condition code, see “Conditional Execution” .

S is an optional suffix. If S is specified, the condition code flags are updated on the result of the operation, see “Conditional Execution” .

Rd is the destination register. If *Rd* is omitted, the destination register is *Rn*.

Rn, Rm are registers holding the values to be multiplied.

Ra is a register holding the value to be added or subtracted from.

Operation

The MUL instruction multiplies the values from *Rn* and *Rm*, and places the least significant 32 bits of the result in *Rd*.

The MLA instruction multiplies the values from *Rn* and *Rm*, adds the value from *Ra*, and places the least significant 32 bits of the result in *Rd*.

The MLS instruction multiplies the values from *Rn* and *Rm*, subtracts the product from the value from *Ra*, and places the least significant 32 bits of the result in *Rd*.

The results of these instructions do not depend on whether the operands are signed or unsigned.

Restrictions

In these instructions, do not use SP and do not use PC.

If the S suffix is used with the MUL instruction:

- *Rd*, *Rn*, and *Rm* must all be in the range R0 to R7
- *Rd* must be the same as *Rm*
- the *cond* suffix must not be used.

Condition Flags

If S is specified, the MUL instruction:

- updates the N and Z flags according to the result
- does not affect the C and V flags.

Examples

```
MUL    R10, R2, R5      ; Multiply, R10 = R2 x R5
MLA    R10, R2, R1, R5 ; Multiply with accumulate, R10 = (R2 x R1) + R5
MULS   R0, R2, R2      ; Multiply with flag update, R0 = R2 x R2
MULLT  R2, R3, R2      ; Conditionally multiply, R2 = R3 x R2
MLS    R4, R5, R6, R7  ; Multiply with subtract, R4 = R7 - (R5 x R6)
```

11.6.6.2 UMULL, UMAAL, UMLAL

Unsigned Long Multiply, with optional Accumulate, using 32-bit operands and producing a 64-bit result.

Syntax

```
op{cond} RdLo, RdHi, Rn, Rm
```

where:

op	is one of: UMULL Unsigned Long Multiply. UMAAL Unsigned Long Multiply with Accumulate Accumulate. UMLAL Unsigned Long Multiply, with Accumulate.
cond	is an optional condition code, see “Conditional Execution” .
RdHi, RdLo	are the destination registers. For UMAAL, UMLAL and UMLAL they also hold the accumulating value.
Rn, Rm	are registers holding the first and second operands.

Operation

These instructions interpret the values from *Rn* and *Rm* as unsigned 32-bit integers.

The UMULL instruction:

- Multiplies the two unsigned integers in the first and second operands.
- Writes the least significant 32 bits of the result in *RdLo*.
- Writes the most significant 32 bits of the result in *RdHi*.

The UMAAL instruction:

- Multiplies the two unsigned 32-bit integers in the first and second operands.
- Adds the unsigned 32-bit integer in *RdHi* to the 64-bit result of the multiplication.
- Adds the unsigned 32-bit integer in *RdLo* to the 64-bit result of the addition.
- Writes the top 32-bits of the result to *RdHi*.
- Writes the lower 32-bits of the result to *RdLo*.

The UMLAL instruction:

- multiplies the two unsigned integers in the first and second operands.
- Adds the 64-bit result to the 64-bit unsigned integer contained in *RdHi* and *RdLo*.
- Writes the result back to *RdHi* and *RdLo*.

Restrictions

In these instructions:

- do not use SP and do not use PC.
- *RdHi* and *RdLo* must be different registers.

Condition Flags

These instructions do not affect the condition code flags.

Examples

```
UMULL   R0, R4, R5, R6 ; Multiplies R5 and R6, writes the top 32 bits to R4
                          ; and the bottom 32 bits to R0
UMAAL   R3, R6, R2, R7 ; Multiplies R2 and R7, adds R6, adds R3, writes the
                          ; top 32 bits to R6, and the bottom 32 bits to R3
UMLAL   R2, R1, R3, R5 ; Multiplies R5 and R3, adds R1:R2, writes to R1:R2.
```

11.6.6.3 SMLA and SMLAW

Signed Multiply Accumulate (halfwords).

Syntax

```
op{XY}{cond} Rd, Rn, Rm
op{Y}{cond} Rd, Rn, Rm, Ra
```

where

op	is one of: SMLA Signed Multiply Accumulate Long (halfwords) X and Y specifies which half of the source registers <i>Rn</i> and <i>Rm</i> are used as the first and second multiply operand. If X is B, then the bottom halfword, bits [15:0], of <i>Rn</i> is used. If X is T, then the top halfword, bits [31:16], of <i>Rn</i> is used. If Y is B, then the bottom halfword, bits [15:0], of <i>Rm</i> is used. If Y is T, then the top halfword, bits [31:16], of <i>Rm</i> is used SMLAW Signed Multiply Accumulate (word by halfword) Y specifies which half of the source register <i>Rm</i> is used as the second multiply operand. If Y is T, then the top halfword, bits [31:16] of <i>Rm</i> is used. If Y is B, then the bottom halfword, bits [15:0] of <i>Rm</i> is used.
cond	is an optional condition code, see “ Conditional Execution ”.
Rd	is the destination register. If <i>Rd</i> is omitted, the destination register is <i>Rn</i> .
Rn, Rm	are registers holding the values to be multiplied.
Ra	is a register holding the value to be added or subtracted from.

Operation

The SMLABB, SMLABT, SMLATB, SMLATT instructions:

- Multiplies the specified signed halfword, top or bottom, values from *Rn* and *Rm*.
- Adds the value in *Ra* to the resulting 32-bit product.
- Writes the result of the multiplication and addition in *Rd*.

The non-specified halfwords of the source registers are ignored.

The SMLAWB and SMLAWT instructions:

- Multiply the 32-bit signed values in *Rn* with:
 - The top signed halfword of *Rm*, T instruction suffix.
 - The bottom signed halfword of *Rm*, B instruction suffix.
- Add the 32-bit signed value in *Ra* to the top 32 bits of the 48-bit product
- Writes the result of the multiplication and addition in *Rd*.

The bottom 16 bits of the 48-bit product are ignored.

If overflow occurs during the addition of the accumulate value, the instruction sets the Q flag in the APSR. No overflow can occur during the multiplication.

Restrictions

In these instructions, do not use SP and do not use PC.

Condition Flags

If an overflow is detected, the Q flag is set.

Examples

```
SMLABB R5, R6, R4, R1 ; Multiplies bottom halfwords of R6 and R4, adds
                    ; R1 and writes to R5
SMLATB R5, R6, R4, R1 ; Multiplies top halfword of R6 with bottom halfword
                    ; of R4, adds R1 and writes to R5
SMLATT R5, R6, R4, R1 ; Multiplies top halfwords of R6 and R4, adds
                    ; R1 and writes the sum to R5
SMLABT R5, R6, R4, R1 ; Multiplies bottom halfword of R6 with top halfword
                    ; of R4, adds R1 and writes to R5
SMLABT R4, R3, R2      ; Multiplies bottom halfword of R4 with top halfword
                    ; of R3, adds R2 and writes to R4
SMLAWB R10, R2, R5, R3 ; Multiplies R2 with bottom halfword of R5, adds
                    ; R3 to the result and writes top 32-bits to R10
SMLAWT R10, R2, R1, R5 ; Multiplies R2 with top halfword of R1, adds R5
                    ; and writes top 32-bits to R10.
```

11.6.6.4 SMLAD

Signed Multiply Accumulate Long Dual

Syntax

```
op{X}{cond} Rd, Rn, Rm, Ra ;
```

where:

op	is one of: SMLAD Signed Multiply Accumulate Dual SMLADX Signed Multiply Accumulate Dual Reverse X specifies which halfword of the source register <i>Rn</i> is used as the multiply operand. If <i>X</i> is omitted, the multiplications are bottom × bottom and top × top. If <i>X</i> is present, the multiplications are bottom × top and top × bottom.
cond	is an optional condition code, see “ Conditional Execution ”.
Rd	is the destination register.
Rn	is the first operand register holding the values to be multiplied.
Rm	the second operand register.
Ra	is the accumulate value.

Operation

The SMLAD and SMLADX instructions regard the two operands as four halfword 16-bit values. The SMLAD and SMLADX instructions:

- If *X* is not present, multiply the top signed halfword value in *Rn* with the top signed halfword of *Rm* and the bottom signed halfword values in *Rn* with the bottom signed halfword of *Rm*.
- Or if *X* is present, multiply the top signed halfword value in *Rn* with the bottom signed halfword of *Rm* and the bottom signed halfword values in *Rn* with the top signed halfword of *Rm*.
- Add both multiplication results to the signed 32-bit value in *Ra*.
- Writes the 32-bit signed result of the multiplication and addition to *Rd*.

Restrictions

Do not use SP and do not use PC.

Condition Flags

These instructions do not change the flags.

Examples

```
SMLAD R10, R2, R1, R5 ; Multiplies two halfword values in R2 with
                        ; corresponding halfwords in R1, adds R5 and writes
                        ; to R10
SMLALDX R0, R2, R4, R6 ; Multiplies top halfword of R2 with bottom halfword
                        ; of R4, multiplies bottom halfword of R2 with top
                        ; halfword of R4, adds R6 and writes to R0.
```

11.6.6.5 SMLAL and SMLALD

Signed Multiply Accumulate Long, Signed Multiply Accumulate Long (halfwords) and Signed Multiply Accumulate Long Dual.

Syntax

```

op{cond} RdLo, RdHi, Rn, Rm
op{XY}{cond} RdLo, RdHi, Rn, Rm
op{X}{cond} RdLo, RdHi, Rn, Rm

```

where:

op	<p>is one of:</p> <ul style="list-style-type: none"> SMLAL Signed Multiply Accumulate Long SMLAL Signed Multiply Accumulate Long (halfwords, X and Y) <p>X and Y specify which halfword of the source registers <i>Rn</i> and <i>Rm</i> are used as the first and second multiply operand:</p> <ul style="list-style-type: none"> If X is B, then the bottom halfword, bits [15:0], of <i>Rn</i> is used. If X is T, then the top halfword, bits [31:16], of <i>Rn</i> is used. If Y is B, then the bottom halfword, bits [15:0], of <i>Rm</i> is used. If Y is T, then the top halfword, bits [31:16], of <i>Rm</i> is used. <ul style="list-style-type: none"> SMLALD Signed Multiply Accumulate Long Dual SMLALDX Signed Multiply Accumulate Long Dual Reversed <p>If the X is omitted, the multiplications are bottom x bottom and top x top. If X is present, the multiplications are bottom x top and top x bottom.</p>
cond	<p>is an optional condition code, see “Conditional Execution” .</p>
RdHi, RdLo	<p>are the destination registers. <i>RdLo</i> is the lower 32 bits and <i>RdHi</i> is the upper 32 bits of the 64-bit integer. For SMLAL, SMLALBB, SMLALBT, SMLALTB, SMLALTT, SMLALD and SMLALDX, they also hold the accumulating value.</p>
Rn, Rm	<p>are registers holding the first and second operands.</p>

Operation

The SMLAL instruction:

- Multiplies the two's complement signed word values from *Rn* and *Rm*.
- Adds the 64-bit value in *RdLo* and *RdHi* to the resulting 64-bit product.
- Writes the 64-bit result of the multiplication and addition in *RdLo* and *RdHi*.

The SMLALBB, SMLALBT, SMLALTB and SMLALTT instructions:

- Multiplies the specified signed halfword, Top or Bottom, values from *Rn* and *Rm*.
- Adds the resulting sign-extended 32-bit product to the 64-bit value in *RdLo* and *RdHi*.
- Writes the 64-bit result of the multiplication and addition in *RdLo* and *RdHi*.

The non-specified halfwords of the source registers are ignored.

The SMLALD and SMLALDX instructions interpret the values from *Rn* and *Rm* as four halfword two's complement signed 16-bit integers. These instructions:

- if X is not present, multiply the top signed halfword value of *Rn* with the top signed halfword of *Rm* and the bottom signed halfword values of *Rn* with the bottom signed halfword of *Rm*.
- Or if X is present, multiply the top signed halfword value of *Rn* with the bottom signed halfword of *Rm* and the bottom signed halfword values of *Rn* with the top signed halfword of *Rm*.

- Add the two multiplication results to the signed 64-bit value in *RdLo* and *RdHi* to create the resulting 64-bit product.
- Write the 64-bit product in *RdLo* and *RdHi*.

Restrictions

In these instructions:

- do not use SP and do not use PC.
- *RdHi* and *RdLo* must be different registers.

Condition Flags

These instructions do not affect the condition code flags.

Examples

```

SMLAL      R4, R5, R3, R8 ; Multiplies R3 and R8, adds R5:R4 and writes to
                ; R5:R4
SMLALBT    R2, R1, R6, R7 ; Multiplies bottom halfword of R6 with top
                ; halfword of R7, sign extends to 32-bit, adds
                ; R1:R2 and writes to R1:R2
SMLALTB    R2, R1, R6, R7 ; Multiplies top halfword of R6 with bottom
                ; halfword of R7, sign extends to 32-bit, adds
                ; R1:R2 and writes to R1:R2
SMLALD     R6, R8, R5, R1 ; Multiplies top halfwords in R5 and R1 and
                ; bottom halfwords of R5 and R1, adds R8:R6 and
                ; writes to R8:R6
SMLALDX    R6, R8, R5, R1 ; Multiplies top halfword in R5 with bottom
                ; halfword of R1, and bottom halfword of R5 with
                ; top halfword of R1, adds R8:R6 and writes to
                ; R8:R6.
    
```

11.6.6.6 SMLSD and SMLS LD

Signed Multiply Subtract Dual and Signed Multiply Subtract Long Dual

Syntax

```
op{X}{cond} Rd, Rn, Rm, Ra
```

where:

op is one of:
 SMLSD Signed Multiply Subtract Dual.
 SMLSDX Signed Multiply Subtract Dual Reversed
 SMLS LD Signed Multiply Subtract Long Dual.
 SMLS LDX Signed Multiply Subtract Long Dual Reversed.
 If *X* is present, the multiplications are bottom × top and top × bottom.
 If the *X* is omitted, the multiplications are bottom × bottom and top × top.

cond is an optional condition code, see “[Conditional Execution](#)”.

Rd is the destination register.

Rn, Rm are registers holding the first and second operands.

Ra is the register holding the accumulate value.

Operation

The SMLSD instruction interprets the values from the first and second operands as four signed halfwords. This instruction:

- Optionally rotates the halfwords of the second operand.
- Performs two signed 16 × 16-bit halfword multiplications.
- Subtracts the result of the upper halfword multiplication from the result of the lower halfword multiplication.
- Adds the signed accumulate value to the result of the subtraction.
- Writes the result of the addition to the destination register.

The SMLSXD instruction interprets the values from *Rn* and *Rm* as four signed halfwords.

This instruction:

- Optionally rotates the halfwords of the second operand.
- Performs two signed 16 × 16-bit halfword multiplications.
- Subtracts the result of the upper halfword multiplication from the result of the lower halfword multiplication.
- Adds the 64-bit value in *RdHi* and *RdLo* to the result of the subtraction.
- Writes the 64-bit result of the addition to the *RdHi* and *RdLo*.

Restrictions

In these instructions:

- Do not use SP and do not use PC.

Condition Flags

This instruction sets the Q flag if the accumulate operation overflows. Overflow cannot occur during the multiplications or subtraction.

For the Thumb instruction set, these instructions do not affect the condition code flags.

Examples

```

SMLSD      R0, R4, R5, R6 ; Multiplies bottom halfword of R4 with bottom
                        ; halfword of R5, multiplies top halfword of R4
                        ; with top halfword of R5, subtracts second from
                        ; first, adds R6, writes to R0

SMLSXD     R1, R3, R2, R0 ; Multiplies bottom halfword of R3 with top
                        ; halfword of R2, multiplies top halfword of R3
                        ; with bottom halfword of R2, subtracts second
                        ; from first, adds R0, writes to R1

SMLSXD     R3, R6, R2, R7 ; Multiplies bottom halfword of R6 with bottom
                        ; halfword of R2, multiplies top halfword of R6
                        ; with top halfword of R2, subtracts second from
                        ; first, adds R6:R3, writes to R6:R3

SMLSXD     R3, R6, R2, R7 ; Multiplies bottom halfword of R6 with top
                        ; halfword of R2, multiplies top halfword of R6
                        ; with bottom halfword of R2, subtracts second
                        ; from first, adds R6:R3, writes to R6:R3.

```

11.6.6.7 SMMLA and SMMLS

Signed Most Significant Word Multiply Accumulate and Signed Most Significant Word Multiply Subtract

Syntax

$op\{R\}\{cond\} Rd, Rn, Rm, Ra$

where:

op	is one of: SMMLA Signed Most Significant Word Multiply Accumulate. SMMLS Signed Most Significant Word Multiply Subtract.
R	is a rounding error flag. If <i>R</i> is specified, the result is rounded instead of being truncated. In this case the constant 0x80000000 is added to the product before the high word is extracted.
cond	is an optional condition code, see “Conditional Execution” .
Rd	is the destination register.
Rn, Rm	are registers holding the first and second multiply operands.
Ra	is the register holding the accumulate value.

Operation

The SMMLA instruction interprets the values from *Rn* and *Rm* as signed 32-bit words.

The SMMLA instruction:

- Multiplies the values in *Rn* and *Rm*.
- Optionally rounds the result by adding 0x80000000.
- Extracts the most significant 32 bits of the result.
- Adds the value of *Ra* to the signed extracted value.
- Writes the result of the addition in *Rd*.

The SMMLS instruction interprets the values from *Rn* and *Rm* as signed 32-bit words.

The SMMLS instruction:

- Multiplies the values in *Rn* and *Rm*.
- Optionally rounds the result by adding 0x80000000.
- Extracts the most significant 32 bits of the result.
- Subtracts the extracted value of the result from the value in *Ra*.
- Writes the result of the subtraction in *Rd*.

Restrictions

In these instructions:

- Do not use SP and do not use PC.

Condition Flags

These instructions do not affect the condition code flags.

Examples

```

SMMLA    R0, R4, R5, R6 ; Multiplies R4 and R5, extracts top 32 bits,
                               ; adds R6, truncates and writes to R0
SMMLAR   R6, R2, R1, R4 ; Multiplies R2 and R1, extracts top 32 bits,
                               ; adds R4, rounds and writes to R6
SMMLSR   R3, R6, R2, R7 ; Multiplies R6 and R2, extracts top 32 bits,
                               ; subtracts R7, rounds and writes to R3
SMMLS    R4, R5, R3, R8 ; Multiplies R5 and R3, extracts top 32 bits,
                               ; subtracts R8, truncates and writes to R4.

```

11.6.6.8 SMMUL

Signed Most Significant Word Multiply

Syntax

```
op{R}{cond} Rd, Rn, Rm
```

where:

op is one of:
SMMUL Signed Most Significant Word Multiply

R is a rounding error flag. If *R* is specified, the result is rounded instead of being truncated. In this case the constant 0x80000000 is added to the product before the high word is extracted.

cond is an optional condition code, see [“Conditional Execution”](#).

Rd is the destination register.

Rn, Rm are registers holding the first and second operands.

Operation

The SMMUL instruction interprets the values from *Rn* and *Rm* as two’s complement 32-bit signed integers. The SMMUL instruction:

- Multiplies the values from *Rn* and *Rm*.
- Optionally rounds the result, otherwise truncates the result.
- Writes the most significant signed 32 bits of the result in *Rd*.

Restrictions

In this instruction:

- do not use SP and do not use PC.

Condition Flags

This instruction does not affect the condition code flags.

Examples

```

SMULL    R0, R4, R5 ; Multiplies R4 and R5, truncates top 32 bits
                               ; and writes to R0
SMULLR   R6, R2 ; Multiplies R6 and R2, rounds the top 32 bits
                               ; and writes to R6.

```

11.6.6.9 SMUAD and SMUSD

Signed Dual Multiply Add and Signed Dual Multiply Subtract

Syntax

$op\{X\}\{cond\} Rd, Rn, Rm$

where:

op	is one of: SMUAD Signed Dual Multiply Add. SMUADX Signed Dual Multiply Add Reversed. SMUSD Signed Dual Multiply Subtract. SMUSDX Signed Dual Multiply Subtract Reversed. If X is present, the multiplications are bottom × top and top × bottom. If the X is omitted, the multiplications are bottom × bottom and top × top.
cond	is an optional condition code, see “Conditional Execution” .
Rd	is the destination register.
Rn, Rm	are registers holding the first and the second operands.

Operation

The SMUAD instruction interprets the values from the first and second operands as two signed halfwords in each operand. This instruction:

- Optionally rotates the halfwords of the second operand.
- Performs two signed 16 × 16-bit multiplications.
- Adds the two multiplication results together.
- Writes the result of the addition to the destination register.

The SMUSD instruction interprets the values from the first and second operands as two's complement signed integers. This instruction:

- Optionally rotates the halfwords of the second operand.
- Performs two signed 16 × 16-bit multiplications.
- Subtracts the result of the top halfword multiplication from the result of the bottom halfword multiplication.
- Writes the result of the subtraction to the destination register.

Restrictions

In these instructions:

- Do not use SP and do not use PC.

Condition Flags

Sets the Q flag if the addition overflows. The multiplications cannot overflow.

Examples

```

SMUAD    R0, R4, R5 ; Multiplies bottom halfword of R4 with the bottom
                ; halfword of R5, adds multiplication of top halfword
                ; of R4 with top halfword of R5, writes to R0
SMUADX   R3, R7, R4 ; Multiplies bottom halfword of R7 with top halfword
                ; of R4, adds multiplication of top halfword of R7
                ; with bottom halfword of R4, writes to R3
SMUSD    R3, R6, R2 ; Multiplies bottom halfword of R4 with bottom halfword
                ; of R6, subtracts multiplication of top halfword of
                ; R6 with top halfword of R3, writes to R3
SMUSDX   R4, R5, R3 ; Multiplies bottom halfword of R5 with top halfword
                ; of R3, subtracts multiplication of top halfword of
                ; R5 with bottom halfword of R3, writes to R4.

```

11.6.6.10 SMUL and SMULW

Signed Multiply (halfwords) and Signed Multiply (word by halfword)

Syntax

```

op{XY}{cond} Rd, Rn, Rm
op{Y}{cond} Rd. Rn, Rm

```

For *SMULXY* only:

op is one of:

- SMUL{XY} Signed Multiply (halfwords)
X and Y specify which halfword of the source registers *Rn* and *Rm* is used as the first and second multiply operand.
If X is B, then the bottom halfword, bits [15:0] of *Rn* is used.
If X is T, then the top halfword, bits [31:16] of *Rn* is used. If Y is B, then the bottom halfword, bits [15:0], of *Rm* is used.
If Y is T, then the top halfword, bits [31:16], of *Rm* is used.
- SMULW{Y} Signed Multiply (word by halfword)
Y specifies which halfword of the source register *Rm* is used as the second multiply operand.
If Y is B, then the bottom halfword (bits [15:0]) of *Rm* is used.
If Y is T, then the top halfword (bits [31:16]) of *Rm* is used.

cond is an optional condition code, see [“Conditional Execution”](#).

Rd is the destination register.

Rn, Rm are registers holding the first and second operands.

Operation

The SMULBB, SMULTB, SMULBT and SMULTT instructions interprets the values from *Rn* and *Rm* as four signed 16-bit integers. These instructions:

- Multiplies the specified signed halfword, Top or Bottom, values from *Rn* and *Rm*.
- Writes the 32-bit result of the multiplication in *Rd*.

The SMULWT and SMULWB instructions interprets the values from *Rn* as a 32-bit signed integer and *Rm* as two halfword 16-bit signed integers. These instructions:

- Multiplies the first operand and the top, T suffix, or the bottom, B suffix, halfword of the second operand.
- Writes the signed most significant 32 bits of the 48-bit result in the destination register.

Restrictions

In these instructions:

- Do not use SP and do not use PC.
- *RdHi* and *RdLo* must be different registers.

Examples

```
SMULBT    R0, R4, R5 ; Multiplies the bottom halfword of R4 with the
              ; top halfword of R5, multiplies results and
              ; writes to R0
SMULBB    R0, R4, R5 ; Multiplies the bottom halfword of R4 with the
              ; bottom halfword of R5, multiplies results and
              ; writes to R0
SMULTT    R0, R4, R5 ; Multiplies the top halfword of R4 with the top
              ; halfword of R5, multiplies results and writes
              ; to R0
SMULTB    R0, R4, R5 ; Multiplies the top halfword of R4 with the
              ; bottom halfword of R5, multiplies results and
              ; and writes to R0
SMULWT    R4, R5, R3 ; Multiplies R5 with the top halfword of R3,
              ; extracts top 32 bits and writes to R4
SMULWB    R4, R5, R3 ; Multiplies R5 with the bottom halfword of R3,
              ; extracts top 32 bits and writes to R4.
```

11.6.6.11 UMULL, UMLAL, SMULL, and SMLAL

Signed and Unsigned Long Multiply, with optional Accumulate, using 32-bit operands and producing a 64-bit result.

Syntax

```
op{cond} RdLo, RdHi, Rn, Rm
```

where:

op	is one of: UMULL Unsigned Long Multiply. UMLAL Unsigned Long Multiply, with Accumulate. SMULL Signed Long Multiply. SMLAL Signed Long Multiply, with Accumulate.
cond	is an optional condition code, see “Conditional Execution” .
RdHi, RdLo	are the destination registers. For UMLAL and SMLAL they also hold the accumulating value.
Rn, Rm	are registers holding the operands.

Operation

The UMULL instruction interprets the values from *Rn* and *Rm* as unsigned integers. It multiplies these integers and places the least significant 32 bits of the result in *RdLo*, and the most significant 32 bits of the result in *RdHi*.

The UMLAL instruction interprets the values from *Rn* and *Rm* as unsigned integers. It multiplies these integers, adds the 64-bit result to the 64-bit unsigned integer contained in *RdHi* and *RdLo*, and writes the result back to *RdHi* and *RdLo*.

The SMULL instruction interprets the values from *Rn* and *Rm* as two’s complement signed integers. It multiplies these integers and places the least significant 32 bits of the result in *RdLo*, and the most significant 32 bits of the result in *RdHi*.

The SMLAL instruction interprets the values from *Rn* and *Rm* as two’s complement signed integers. It multiplies these integers, adds the 64-bit result to the 64-bit signed integer contained in *RdHi* and *RdLo*, and writes the result back to *RdHi* and *RdLo*.

Restrictions

In these instructions:

- do not use SP and do not use PC
- *RdHi* and *RdLo* must be different registers.

Condition Flags

These instructions do not affect the condition code flags.

Examples

```
UMULL    R0, R4, R5, R6    ; Unsigned (R4,R0) = R5 x R6
SMLAL   R4, R5, R3, R8    ; Signed (R5,R4) = (R5,R4) + R3 x R8
```

11.6.6.12 SDIV and UDIV

Signed Divide and Unsigned Divide.

Syntax

```
SDIV{cond} {Rd,} Rn, Rm
UDIV{cond} {Rd,} Rn, Rm
```

where:

cond is an optional condition code, see [“Conditional Execution”](#) .
 Rd is the destination register. If Rd is omitted, the destination register is Rn.
 Rn is the register holding the value to be divided.
 Rm is a register holding the divisor.

Operation

SDIV performs a signed integer division of the value in Rn by the value in Rm.

UDIV performs an unsigned integer division of the value in Rn by the value in Rm.

For both instructions, if the value in Rn is not divisible by the value in Rm, the result is rounded towards zero.

Restrictions

Do not use SP and do not use PC.

Condition Flags

These instructions do not change the flags.

Examples

```
SDIV R0, R2, R4 ; Signed divide, R0 = R2/R4
UDIV R8, R8, R1 ; Unsigned divide, R8 = R8/R1
```

11.6.7 Saturating Instructions

The table below shows the saturating instructions:

Table 11-22. Saturating Instructions

Mnemonic	Description
SSAT	Signed Saturate
SSAT16	Signed Saturate Halfword
USAT	Unsigned Saturate
USAT16	Unsigned Saturate Halfword
QADD	Saturating Add
QSUB	Saturating Subtract
QSUB16	Saturating Subtract 16
QASX	Saturating Add and Subtract with Exchange
QSAX	Saturating Subtract and Add with Exchange
QDADD	Saturating Double and Add
QDSUB	Saturating Double and Subtract
UQADD16	Unsigned Saturating Add 16
UQADD8	Unsigned Saturating Add 8
UQASX	Unsigned Saturating Add and Subtract with Exchange
UQSAX	Unsigned Saturating Subtract and Add with Exchange
UQSUB16	Unsigned Saturating Subtract 16
UQSUB8	Unsigned Saturating Subtract 8

For signed n -bit saturation, this means that:

- if the value to be saturated is less than -2^{n-1} , the result returned is -2^{n-1}
- if the value to be saturated is greater than $2^{n-1}-1$, the result returned is $2^{n-1}-1$
- otherwise, the result returned is the same as the value to be saturated.

For unsigned n -bit saturation, this means that:

- if the value to be saturated is less than 0, the result returned is 0
- if the value to be saturated is greater than 2^n-1 , the result returned is 2^n-1
- otherwise, the result returned is the same as the value to be saturated.

If the returned result is different from the value to be saturated, it is called *saturation*. If saturation occurs, the instruction sets the Q flag to 1 in the APSR. Otherwise, it leaves the Q flag unchanged. To clear the Q flag to 0, the MSR instruction must be used; see “MSR” .

To read the state of the Q flag, the MRS instruction must be used; see “MRS” .

11.6.7.1 SSAT and USAT

Signed Saturate and Unsigned Saturate to any bit position, with optional shift before saturating.

Syntax

```
op{cond} Rd, #n, Rm {, shift #s}
```

where:

op	is one of: SSAT Saturates a signed value to a signed range. USAT Saturates a signed value to an unsigned range.
cond	is an optional condition code, see "Conditional Execution" .
Rd	is the destination register.
n	specifies the bit position to saturate to: n ranges from 1 to 32 for SSAT n ranges from 0 to 31 for USAT.
Rm	is the register containing the value to saturate.
shift #s	is an optional shift applied to Rm before saturating. It must be one of the following: ASR #s where s is in the range 1 to 31 LSL #s where s is in the range 0 to 31.

Operation

These instructions saturate to a signed or unsigned n -bit value.

The SSAT instruction applies the specified shift, then saturates to the signed range $-2^{n-1} \leq x \leq 2^{n-1}-1$.

The USAT instruction applies the specified shift, then saturates to the unsigned range $0 \leq x \leq 2^n-1$.

Restrictions

Do not use SP and do not use PC.

Condition Flags

These instructions do not affect the condition code flags.

If saturation occurs, these instructions set the Q flag to 1.

Examples

```
SSAT    R7, #16, R7, LSL #4 ; Logical shift left value in R7 by 4, then
                                ; saturate it as a signed 16-bit value and
                                ; write it back to R7
USATNE  R0, #7, R5          ; Conditionally saturate value in R5 as an
                                ; unsigned 7 bit value and write it to R0.
```

11.6.7.2 SSAT16 and USAT16

Signed Saturate and Unsigned Saturate to any bit position for two halfwords.

Syntax

```
op{cond} Rd, #n, Rm
```

where:

op	is one of: SSAT16 Saturates a signed halfword value to a signed range. USAT16 Saturates a signed halfword value to an unsigned range.
cond	is an optional condition code, see "Conditional Execution" .
Rd	is the destination register.
n	specifies the bit position to saturate to:
n ranges from 1 to 16 for SSAT.	n ranges from 0 to 15 for USAT.
Rm	is the register containing the value to saturate.

Operation

The SSAT16 instruction:

Saturates two signed 16-bit halfword values of the register with the value to saturate from selected by the bit position in *n*.

Writes the results as two signed 16-bit halfwords to the destination register.

The USAT16 instruction:

Saturates two unsigned 16-bit halfword values of the register with the value to saturate from selected by the bit position in *n*.

Writes the results as two unsigned halfwords in the destination register.

Restrictions

Do not use SP and do not use PC.

Condition Flags

These instructions do not affect the condition code flags.

If saturation occurs, these instructions set the Q flag to 1.

Examples

```
SSAT16   R7, #9, R2    ; Saturates the top and bottom highwords of R2
           ; as 9-bit values, writes to corresponding halfword
           ; of R7
USAT16NE R0, #13, R5   ; Conditionally saturates the top and bottom
           ; halfwords of R5 as 13-bit values, writes to
           ; corresponding halfword of R0.
```

11.6.7.3 QADD and QSUB

Saturating Add and Saturating Subtract, signed.

Syntax

```

op{cond} {Rd}, Rn, Rm
op{cond} {Rd}, Rn, Rm
    
```

where:

op is one of:
 QADD Saturating 32-bit add.
 QADD8 Saturating four 8-bit integer additions.
 QADD16 Saturating two 16-bit integer additions.
 QSUB Saturating 32-bit subtraction.
 QSUB8 Saturating four 8-bit integer subtraction.
 QSUB16 Saturating two 16-bit integer subtraction.

cond is an optional condition code, see [“Conditional Execution”](#).

Rd is the destination register.

Rn, Rm are registers holding the first and second operands.

Operation

These instructions add or subtract two, four or eight values from the first and second operands and then writes a signed saturated value in the destination register.

The QADD and QSUB instructions apply the specified add or subtract, and then saturate the result to the signed range $-2^{n-1} \leq x \leq 2^{n-1}-1$, where x is given by the number of bits applied in the instruction, 32, 16 or 8.

If the returned result is different from the value to be saturated, it is called *saturation*. If saturation occurs, the QADD and QSUB instructions set the Q flag to 1 in the APSR. Otherwise, it leaves the Q flag unchanged. The 8-bit and 16-bit QADD and QSUB instructions always leave the Q flag unchanged.

To clear the Q flag to 0, the MSR instruction must be used; see [“MSR”](#).

To read the state of the Q flag, the MRS instruction must be used; see [“MRS”](#).

Restrictions

Do not use SP and do not use PC.

Condition Flags

These instructions do not affect the condition code flags.

If saturation occurs, these instructions set the Q flag to 1.

Examples

```

QADD16  R7, R4, R2 ; Adds halfwords of R4 with corresponding halfword of
                  ; R2, saturates to 16 bits and writes to corresponding
                  ; halfword of R7
QADD8   R3, R1, R6 ; Adds bytes of R1 to the corresponding bytes of R6,
                  ; saturates to 8 bits and writes to corresponding byte
                  ; of R3
    
```

QSUB16 R4, R2, R3 ; Subtracts halfwords of R3 from corresponding halfword
 ; of R2, saturates to 16 bits, writes to corresponding
 ; halfword of R4
 QSUB8 R4, R2, R5 ; Subtracts bytes of R5 from the corresponding byte in
 ; R2, saturates to 8 bits, writes to corresponding byte
 ; of R4.

11.6.7.4 QASX and QSAX

Saturating Add and Subtract with Exchange and Saturating Subtract and Add with Exchange, signed.

Syntax

op{*cond*} {*Rd*}, *Rm*, *Rn*

where:

op is one of:
 QASX Add and Subtract with Exchange and Saturate.
 QSAX Subtract and Add with Exchange and Saturate.
cond is an optional condition code, see [“Conditional Execution”](#).
Rd is the destination register.
Rn, Rm are registers holding the first and second operands.

Operation

The QASX instruction:

1. Adds the top halfword of the source operand with the bottom halfword of the second operand.
2. Subtracts the top halfword of the second operand from the bottom highword of the first operand.
3. Saturates the result of the subtraction and writes a 16-bit signed integer in the range $-2^{15} \leq x \leq 2^{15} - 1$, where x equals 16, to the bottom halfword of the destination register.
4. Saturates the results of the sum and writes a 16-bit signed integer in the range $-2^{15} \leq x \leq 2^{15} - 1$, where x equals 16, to the top halfword of the destination register.

The QSAX instruction:

1. Subtracts the bottom halfword of the second operand from the top highword of the first operand.
2. Adds the bottom halfword of the source operand with the top halfword of the second operand.
3. Saturates the results of the sum and writes a 16-bit signed integer in the range $-2^{15} \leq x \leq 2^{15} - 1$, where x equals 16, to the bottom halfword of the destination register.
4. Saturates the result of the subtraction and writes a 16-bit signed integer in the range $-2^{15} \leq x \leq 2^{15} - 1$, where x equals 16, to the top halfword of the destination register.

Restrictions

Do not use SP and do not use PC.

Condition Flags

These instructions do not affect the condition code flags.

Examples

```

QASX    R7, R4, R2 ; Adds top halfword of R4 to bottom halfword of R2,
           ; saturates to 16 bits, writes to top halfword of R7
           ; Subtracts top highword of R2 from bottom halfword of
           ; R4, saturates to 16 bits and writes to bottom halfword
           ; of R7

QSAX    R0, R3, R5 ; Subtracts bottom halfword of R5 from top halfword of
           ; R3, saturates to 16 bits, writes to top halfword of R0
           ; Adds bottom halfword of R3 to top halfword of R5,
           ; saturates to 16 bits, writes to bottom halfword of R0.
    
```

11.6.7.5 QDADD and QDSUB

Saturating Double and Add and Saturating Double and Subtract, signed.

Syntax

```
op{cond} {Rd}, Rm, Rn
```

where:

op is one of:
 QDADD Saturating Double and Add.
 QDSUB Saturating Double and Subtract.

cond is an optional condition code, see [“Conditional Execution”](#).

Rd is the destination register.

Rm, Rn are registers holding the first and second operands.

Operation

The QDADD instruction:

- Doubles the second operand value.
- Adds the result of the doubling to the signed saturated value in the first operand.
- Writes the result to the destination register.

The QDSUB instruction:

- Doubles the second operand value.
- Subtracts the doubled value from the signed saturated value in the first operand.
- Writes the result to the destination register.

Both the doubling and the addition or subtraction have their results saturated to the 32-bit signed integer range $-2^{31} \leq x \leq 2^{31} - 1$. If saturation occurs in either operation, it sets the Q flag in the APSR.

Restrictions

Do not use SP and do not use PC.

Condition Flags

If saturation occurs, these instructions set the Q flag to 1.

Examples

```

QDADD    R7, R4, R2    ; Doubles and saturates R4 to 32 bits, adds R2,
                    ; saturates to 32 bits, writes to R7
QDSUB    R0, R3, R5    ; Subtracts R3 doubled and saturated to 32 bits
                    ; from R5, saturates to 32 bits, writes to R0.

```

11.6.7.6 UQASX and UQSAX

Saturating Add and Subtract with Exchange and Saturating Subtract and Add with Exchange, unsigned.

Syntax

```
op{cond} {Rd}, Rm, Rn
```

where:

type	is one of: UQASX Add and Subtract with Exchange and Saturate. UQSAX Subtract and Add with Exchange and Saturate.
cond	is an optional condition code, see “Conditional Execution” .
Rd	is the destination register.
Rn, Rm	are registers holding the first and second operands.

Operation

The UQASX instruction:

1. Adds the bottom halfword of the source operand with the top halfword of the second operand.
2. Subtracts the bottom halfword of the second operand from the top highword of the first operand.
3. Saturates the results of the sum and writes a 16-bit unsigned integer in the range $0 \leq x \leq 2^{16} - 1$, where x equals 16, to the top halfword of the destination register.
4. Saturates the result of the subtraction and writes a 16-bit unsigned integer in the range $0 \leq x \leq 2^{16} - 1$, where x equals 16, to the bottom halfword of the destination register.

The UQSAX instruction:

1. Subtracts the bottom halfword of the second operand from the top highword of the first operand.
2. Adds the bottom halfword of the first operand with the top halfword of the second operand.
3. Saturates the result of the subtraction and writes a 16-bit unsigned integer in the range $0 \leq x \leq 2^{16} - 1$, where x equals 16, to the top halfword of the destination register.
4. Saturates the results of the addition and writes a 16-bit unsigned integer in the range $0 \leq x \leq 2^{16} - 1$, where x equals 16, to the bottom halfword of the destination register.

Restrictions

Do not use SP and do not use PC.

Condition Flags

These instructions do not affect the condition code flags.

Examples

```

UQASX  R7, R4, R2 ; Adds top halfword of R4 with bottom halfword of R2,
                  ; saturates to 16 bits, writes to top halfword of R7
                  ; Subtracts top halfword of R2 from bottom halfword of R4
                  ; saturates to 16 bits, writes to bottom halfword of R7
UQSAX  R0, R3, R5 ; Subtracts bottom halfword of R5 from top halfword of R3
                  ; saturates to 16 bits, writes to top halfword of R0
                  ; Adds bottom halfword of R4 to top halfword of R5
                  ; saturates to 16 bits, writes to bottom halfword of R0.
    
```

11.6.7.7 UQADD and UQSUB

Saturating Add and Saturating Subtract Unsigned.

Syntax

```

op{cond} {Rd}, Rn, Rm
op{cond} {Rd}, Rn, Rm
    
```

where:

op is one of:
 UQADD8 Saturating four unsigned 8-bit integer additions.
 UQADD16 Saturating two unsigned 16-bit integer additions.
 UDSUB8 Saturating four unsigned 8-bit integer subtractions.
 UQSUB16 Saturating two unsigned 16-bit integer subtractions.

cond is an optional condition code, see [“Conditional Execution”](#).

Rd is the destination register.

Rn, Rm are registers holding the first and second operands.

Operation

These instructions add or subtract two or four values and then writes an unsigned saturated value in the destination register.

The UQADD16 instruction:

- Adds the respective top and bottom halfwords of the first and second operands.
- Saturates the result of the additions for each halfword in the destination register to the unsigned range $0 \leq x \leq 2^{16}-1$, where x is 16.

The UQADD8 instruction:

- Adds each respective byte of the first and second operands.
- Saturates the result of the addition for each byte in the destination register to the unsigned range $0 \leq x \leq 2^8-1$, where x is 8.

The UQSUB16 instruction:

- Subtracts both halfwords of the second operand from the respective halfwords of the first operand.
- Saturates the result of the differences in the destination register to the unsigned range $0 \leq x \leq 2^{16}-1$, where x is 16.

The UQSUB8 instructions:



- Subtracts the respective bytes of the second operand from the respective bytes of the first operand.
- Saturates the results of the differences for each byte in the destination register to the unsigned range $0 \leq x \leq 2^8 - 1$, where x is 8.

Restrictions

Do not use SP and do not use PC.

Condition Flags

These instructions do not affect the condition code flags.

Examples

```

UQADD16  R7, R4, R2 ; Adds halfwords in R4 to corresponding halfword in R2,
                    ; saturates to 16 bits, writes to corresponding
                    ; halfword of R7
UQADD8   R4, R2, R5 ; Adds bytes of R2 to corresponding byte of R5,
                    ; saturates to 8 bits, writes to corresponding bytes of
                    ; R4
UQSUB16  R6, R3, R0 ; Subtracts halfwords in R0 from corresponding halfword
                    ; in R3, saturates to 16 bits, writes to corresponding
                    ; halfword in R6
UQSUB8   R1, R5, R6 ; Subtracts bytes in R6 from corresponding byte of R5,
                    ; saturates to 8 bits, writes to corresponding byte of
                    ; R1.

```

11.6.8 Packing and Unpacking Instructions

The table below shows the instructions that operate on packing and unpacking data:

Table 11-23. Packing and Unpacking Instructions

Mnemonic	Description
PKH	Pack Halfword
SXTAB	Extend 8 bits to 32 and add
SXTAB16	Dual extend 8 bits to 16 and add
SXTAH	Extend 16 bits to 32 and add
SXTB	Sign extend a byte
SXTB16	Dual extend 8 bits to 16 and add
SXTH	Sign extend a halfword
UXTAB	Extend 8 bits to 32 and add
UXTAB16	Dual extend 8 bits to 16 and add
UXTAH	Extend 16 bits to 32 and add
UXTB	Zero extend a byte
UXTB16	Dual zero extend 8 bits to 16 and add
UXTH	Zero extend a halfword

11.6.8.1 PKHBT and PKHTB

Pack Halfword

Syntax

```
op{cond} {Rd}, Rn, Rm {, LSL #imm}
op{cond} {Rd}, Rn, Rm {, ASR #imm}
```

where:

op	is one of: PKHBT Pack Halfword, bottom and top with shift. PKHTB Pack Halfword, top and bottom with shift.
cond	is an optional condition code, see “ Conditional Execution ”.
Rd	is the destination register.
Rn	is the first operand register.
Rm	is the second operand register holding the value to be optionally shifted. is the shift length. The type of shift length depends on the instruction: For PKHBT LSL a left shift with a shift length from 1 to 31, 0 means no shift.
imm	For PKHTB ASR an arithmetic shift right with a shift length from 1 to 32, a shift of 32-bits is encoded as 0b00000.

Operation

The PKHBT instruction:

1. Writes the value of the bottom halfword of the first operand to the bottom halfword of the destination register.
2. If shifted, the shifted value of the second operand is written to the top halfword of the destination register.

The PKHTB instruction:

1. Writes the value of the top halfword of the first operand to the top halfword of the destination register.
2. If shifted, the shifted value of the second operand is written to the bottom halfword of the destination register.

Restrictions

Rd must not be SP and must not be PC.

Condition Flags

This instruction does not change the flags.

Examples

```
PKHBT   R3, R4, R5 LSL #0 ; Writes bottom halfword of R4 to bottom halfword
                               ; of R3, writes top halfword of R5, unshifted, to
                               ; top halfword of R3
PKHTB   R4, R0, R2 ASR #1 ; Writes R2 shifted right by 1 bit to bottom
                               ; halfword of R4, and writes top halfword of R0
                               ; to top halfword of R4.
```

11.6.8.2 SXT and UXT

Sign extend and Zero extend.

Syntax

```
op{cond} {Rd,} Rm {, ROR #n}
op{cond} {Rd}, Rm {, ROR #n}
```

where:

op is one of:
 SXTB Sign extends an 8-bit value to a 32-bit value.
 SXTH Sign extends a 16-bit value to a 32-bit value.
 SXTB16 Sign extends two 8-bit values to two 16-bit values.
 UXTB Zero extends an 8-bit value to a 32-bit value.
 UXTH Zero extends a 16-bit value to a 32-bit value.
 UXTB16 Zero extends two 8-bit values to two 16-bit values.

cond is an optional condition code, see [“Conditional Execution”](#).

Rd is the destination register.

Rm is the register holding the value to extend.

ROR #n is one of:
 ROR #8 Value from *Rm* is rotated right 8 bits.
 ROR #16 Value from *Rm* is rotated right 16 bits.
 ROR #24 Value from *Rm* is rotated right 24 bits.
 If ROR #*n* is omitted, no rotation is performed.

Operation

These instructions do the following:

1. Rotate the value from *Rm* right by 0, 8, 16 or 24 bits.
2. Extract bits from the resulting value:
 - SXTB extracts bits[7:0] and sign extends to 32 bits.
 - UXTB extracts bits[7:0] and zero extends to 32 bits.
 - SXTH extracts bits[15:0] and sign extends to 32 bits.
 - UXTH extracts bits[15:0] and zero extends to 32 bits.
 - SXTB16 extracts bits[7:0] and sign extends to 16 bits, and extracts bits [23:16] and sign extends to 16 bits.
 - UXTB16 extracts bits[7:0] and zero extends to 16 bits, and extracts bits [23:16] and zero extends to 16 bits.

Restrictions

Do not use SP and do not use PC.

Condition Flags

These instructions do not affect the flags.

Examples

```
SXTH R4, R6, ROR #16 ; Rotates R6 right by 16 bits, obtains bottom
                    ; halfword of result, sign extends to 32 bits and
                    ; writes to R4
UXTB R3, R10        ; Extracts lowest byte of value in R10, zero extends,
                    ; and writes to R3.
```

11.6.8.3 SXTA and UXTA

Signed and Unsigned Extend and Add

Syntax

```

op{cond} {Rd,} Rn, Rm {, ROR #n}
op{cond} {Rd,} Rn, Rm {, ROR #n}

```

where:

op is one of:

SXTAB Sign extends an 8-bit value to a 32-bit value and add.

SXTAH Sign extends a 16-bit value to a 32-bit value and add.

SXTAB16 Sign extends two 8-bit values to two 16-bit values and add.

UXTAB Zero extends an 8-bit value to a 32-bit value and add.

UXTAH Zero extends a 16-bit value to a 32-bit value and add.

UXTAB16 Zero extends two 8-bit values to two 16-bit values and add.

cond is an optional condition code, see [“Conditional Execution”](#).

Rd is the destination register.

Rn is the first operand register.

Rm is the register holding the value to rotate and extend.

ROR #n is one of:

ROR #8 Value from *Rm* is rotated right 8 bits.

ROR #16 Value from *Rm* is rotated right 16 bits.

ROR #24 Value from *Rm* is rotated right 24 bits.

If ROR #n is omitted, no rotation is performed.

Operation

These instructions do the following:

1. Rotate the value from *Rm* right by 0, 8, 16 or 24 bits.
2. Extract bits from the resulting value:
 - SXTAB extracts bits[7:0] from *Rm* and sign extends to 32 bits.
 - UXTAB extracts bits[7:0] from *Rm* and zero extends to 32 bits.
 - SXTAH extracts bits[15:0] from *Rm* and sign extends to 32 bits.
 - UXTAH extracts bits[15:0] from *Rm* and zero extends to 32 bits.
 - SXTAB16 extracts bits[7:0] from *Rm* and sign extends to 16 bits, and extracts bits [23:16] from *Rm* and sign extends to 16 bits.
 - UXTAB16 extracts bits[7:0] from *Rm* and zero extends to 16 bits, and extracts bits [23:16] from *Rm* and zero extends to 16 bits.
3. Adds the signed or zero extended value to the word or corresponding halfword of *Rn* and writes the result in *Rd*.

Restrictions

Do not use SP and do not use PC.

Condition Flags

These instructions do not affect the flags.

Examples

```
SXTAH R4, R8, R6, ROR #16 ; Rotates R6 right by 16 bits, obtains bottom
                           ; halfword, sign extends to 32 bits, adds R8, and
                           ; writes to R4
UXTAB R3, R4, R10        ; Extracts bottom byte of R10 and zero extends to
                           ; 32 bits, adds R4, and writes to R3.
```

11.6.9 Bitfield Instructions

The table below shows the instructions that operate on adjacent sets of bits in registers or bitfields:

Table 11-24. Packing and Unpacking Instructions

Mnemonic	Description
BFC	Bit Field Clear
BFI	Bit Field Insert
SBFX	Signed Bit Field Extract
SXTB	Sign extend a byte
SXTH	Sign extend a halfword
UBFX	Unsigned Bit Field Extract
UXTB	Zero extend a byte
UXTH	Zero extend a halfword

11.6.9.1 BFC and BFI

Bit Field Clear and Bit Field Insert.

Syntax

```
BFC{cond} Rd, #lsb, #width
BFI{cond} Rd, Rn, #lsb, #width
```

where:

cond is an optional condition code, see [“Conditional Execution”](#) .
Rd is the destination register.
Rn is the source register.
lsb is the position of the least significant bit of the bitfield. *lsb* must be in the range 0 to 31.
width is the width of the bitfield and must be in the range 1 to 32-*lsb*.

Operation

BFC clears a bitfield in a register. It clears *width* bits in *Rd*, starting at the low bit position *lsb*. Other bits in *Rd* are unchanged.

BFI copies a bitfield into one register from another register. It replaces *width* bits in *Rd* starting at the low bit position *lsb*, with *width* bits from *Rn* starting at bit[0]. Other bits in *Rd* are unchanged.

Restrictions

Do not use SP and do not use PC.

Condition Flags

These instructions do not affect the flags.

Examples

```
BFC  R4, #8, #12      ; Clear bit 8 to bit 19 (12 bits) of R4 to 0
BFI  R9, R2, #8, #12  ; Replace bit 8 to bit 19 (12 bits) of R9 with
                       ; bit 0 to bit 11 from R2.
```

11.6.9.2 SBFX and UBFX

Signed Bit Field Extract and Unsigned Bit Field Extract.

Syntax

```
SBFX{cond} Rd, Rn, #lsb, #width
UBFX{cond} Rd, Rn, #lsb, #width
```

where:

cond is an optional condition code, see [“Conditional Execution”](#).

Rd is the destination register.

Rn is the source register.

lsb is the position of the least significant bit of the bitfield. *lsb* must be in the range 0 to 31.

width is the width of the bitfield and must be in the range 1 to 32-*lsb*.

Operation

SBFX extracts a bitfield from one register, sign extends it to 32 bits, and writes the result to the destination register.

UBFX extracts a bitfield from one register, zero extends it to 32 bits, and writes the result to the destination register.

Restrictions

Do not use SP and do not use PC.

Condition Flags

These instructions do not affect the flags.

Examples

```
SBFX R0, R1, #20, #4 ; Extract bit 20 to bit 23 (4 bits) from R1 and sign
                       ; extend to 32 bits and then write the result to R0.
UBFX R8, R11, #9, #10 ; Extract bit 9 to bit 18 (10 bits) from R11 and
                       ; zero, extend to 32 bits and then write the result
                       ; to R8.
```

11.6.9.3 SXT and UXT

Sign extend and Zero extend.

Syntax

```
SXTextend{cond} {Rd}, Rm {, ROR #n}
UXTTextend{cond} {Rd}, Rm {, ROR #n}
```

where:

extend is one of:
 B Extends an 8-bit value to a 32-bit value.
 H Extends a 16-bit value to a 32-bit value.

cond is an optional condition code, see [“Conditional Execution”](#).

Rd is the destination register.

Rm is the register holding the value to extend.

ROR #n is one of:
 ROR #8 Value from *Rm* is rotated right 8 bits.
 ROR #16 Value from *Rm* is rotated right 16 bits.
 ROR #24 Value from *Rm* is rotated right 24 bits.
 . If ROR #*n* is omitted, no rotation is performed

Operation

These instructions do the following:

1. Rotate the value from *Rm* right by 0, 8, 16 or 24 bits.
2. Extract bits from the resulting value:
 - SXTB extracts bits[7:0] and sign extends to 32 bits.
 - UXTB extracts bits[7:0] and zero extends to 32 bits.
 - SXTH extracts bits[15:0] and sign extends to 32 bits.
 - UXTH extracts bits[15:0] and zero extends to 32 bits.

Restrictions

Do not use SP and do not use PC.

Condition Flags

These instructions do not affect the flags.

Examples

```
SXTH R4, R6, ROR #16 ; Rotate R6 right by 16 bits, then obtain the lower
                    ; halfword of the result and then sign extend to
                    ; 32 bits and write the result to R4.
UXTB R3, R10        ; Extract lowest byte of the value in R10 and zero
                    ; extend it, and write the result to R3.
```

11.6.10 Branch and Control Instructions

The table below shows the branch and control instructions:

Table 11-25. Branch and Control Instructions

Mnemonic	Description
B	Branch
BL	Branch with Link
BLX	Branch indirect with Link
BX	Branch indirect
CBNZ	Compare and Branch if Non Zero
CBZ	Compare and Branch if Zero
IT	If-Then
TBB	Table Branch Byte
TBH	Table Branch Halfword

11.6.10.1 B, BL, BX, and BLX

Branch instructions.

Syntax

```
B{cond} label
BL{cond} label
BX{cond} Rm
BLX{cond} Rm
```

where:

B is branch (immediate).
 BL is branch with link (immediate).
 BX is branch indirect (register).
 BLX is branch indirect with link (register).
 cond is an optional condition code, see [“Conditional Execution”](#).
 label is a PC-relative expression. See [“PC-relative Expressions”](#).
 Rm is a register that indicates an address to branch to. Bit[0] of the value in *Rm* must be 1, but the address to branch to is created by changing bit[0] to 0.

Operation

All these instructions cause a branch to *label*, or to the address indicated in *Rm*. In addition:

- The BL and BLX instructions write the address of the next instruction to LR (the link register, R14).
- The BX and BLX instructions result in a UsageFault exception if bit[0] of *Rm* is 0.

Bcond label is the only conditional instruction that can be either inside or outside an IT block. All other branch instructions must be conditional inside an IT block, and must be unconditional outside the IT block, see [“IT”](#).

The table below shows the ranges for the various branch instructions.

Table 11-26. Branch Ranges

Instruction	Branch Range
B label	-16 MB to +16 MB
<i>Bcond</i> label (outside IT block)	-1 MB to +1 MB
<i>Bcond</i> label (inside IT block)	-16 MB to +16 MB
BL{ <i>cond</i> } label	-16 MB to +16 MB
BX{ <i>cond</i> } Rm	Any value in register
BLX{ <i>cond</i> } Rm	Any value in register

The *.W* suffix might be used to get the maximum branch range. See “[Instruction Width Selection](#)”

Restrictions

The restrictions are:

- do not use PC in the BLX instruction
- for BX and BLX, bit[0] of *Rm* must be 1 for correct execution but a branch occurs to the target address created by changing bit[0] to 0
- when any of these instructions is inside an IT block, it must be the last instruction of the IT block.

Bcond is the only conditional instruction that is not required to be inside an IT block. However, it has a longer branch range when it is inside an IT block.

Condition Flags

These instructions do not change the flags.

Examples

```

B      loopA      ; Branch to loopA
BLE   ng         ; Conditionally branch to label ng
B.W   target     ; Branch to target within 16MB range
BEQ   target     ; Conditionally branch to target
BEQ.W target     ; Conditionally branch to target within 1MB
BL    funC       ; Branch with link (Call) to function funC, return
                    ; address stored in LR
BX    LR         ; Return from function call
BXNE  R0         ; Conditionally branch to address stored in R0
BLX   R0         ; Branch with link and exchange (Call) to a address
                    ; stored in R0.

```

11.6.10.2 CBZ and CBNZ

Compare and Branch on Zero, Compare and Branch on Non-Zero.

Syntax

```
CBZ Rn, label
CBNZ Rn, label
```

where:

Rn is the register holding the operand.
label is the branch destination.

Operation

Use the CBZ or CBNZ instructions to avoid changing the condition code flags and to reduce the number of instructions.

CBZ Rn, label does not change condition flags but is otherwise equivalent to:

```
CMP    Rn, #0
BEQ    label
```

CBNZ Rn, label does not change condition flags but is otherwise equivalent to:

```
CMP    Rn, #0
BNE    label
```

Restrictions

The restrictions are:

- Rn must be in the range of R0 to R7
- the branch destination must be within 4 to 130 bytes after the instruction
- these instructions must not be used inside an IT block.

Condition Flags

These instructions do not change the flags.

Examples

```
CBZ    R5, target ; Forward branch if R5 is zero
CBNZ   R0, target ; Forward branch if R0 is not zero
```

If-Then condition instruction.

Syntax

$$IT\{x\{y\{z\}\}\} \textit{cond}$$

where:

x	specifies the condition switch for the second instruction in the IT block.
y	specifies the condition switch for the third instruction in the IT block.
z	specifies the condition switch for the fourth instruction in the IT block.
cond	specifies the condition for the first instruction in the IT block.

The condition switch for the second, third and fourth instruction in the IT block can be either:

T	Then. Applies the condition <i>cond</i> to the instruction.
E	Else. Applies the inverse condition of <i>cond</i> to the instruction.

It is possible to use AL (the *always* condition) for *cond* in an IT instruction. If this is done, all of the instructions in the IT block must be unconditional, and each of x, y, and z must be T or omitted but not E.

Operation

The IT instruction makes up to four following instructions conditional. The conditions can be all the same, or some of them can be the logical inverse of the others. The conditional instructions following the IT instruction form the *IT block*.

The instructions in the IT block, including any branches, must specify the condition in the *{cond}* part of their syntax.

The assembler might be able to generate the required IT instructions for conditional instructions automatically, so that the user does not have to write them. See the assembler documentation for details.

A BKPT instruction in an IT block is always executed, even if its condition fails.

Exceptions can be taken between an IT instruction and the corresponding IT block, or within an IT block. Such an exception results in entry to the appropriate exception handler, with suitable return information in LR and stacked PSR.

Instructions designed for use for exception returns can be used as normal to return from the exception, and execution of the IT block resumes correctly. This is the only way that a PC-modifying instruction is permitted to branch to an instruction in an IT block.

Restrictions

The following instructions are not permitted in an IT block:

- IT
- CBZ and CBNZ
- CPSID and CPSIE.

Other restrictions when using an IT block are:

- a branch or any instruction that modifies the PC must either be outside an IT block or must be the last instruction inside the IT block. These are:
 - ADD PC, PC, Rm

- MOV PC, Rm
 - B, BL, BX, BLX
 - any LDM, LDR, or POP instruction that writes to the PC
 - TBB and TBH
- do not branch to any instruction inside an IT block, except when returning from an exception handler
 - all conditional instructions except *Bcond* must be inside an IT block. *Bcond* can be either outside or inside an IT block but has a larger branch range if it is inside one
 - each instruction inside the IT block must specify a condition code suffix that is either the same or logical inverse as for the other instructions in the block.

Your assembler might place extra restrictions on the use of IT blocks, such as prohibiting the use of assembler directives within them.

Condition Flags

This instruction does not change the flags.

Example

```
ITTE    NE                ; Next 3 instructions are conditional
ANDNE   R0, R0, R1        ; ANDNE does not update condition flags
ADDSNE  R2, R2, #1        ; ADDSNE updates condition flags
MOVEQ   R2, R3            ; Conditional move

CMP     R0, #9            ; Convert R0 hex value (0 to 15) into ASCII
                          ; ('0'-'9', 'A'-'F')
ITE     GT                ; Next 2 instructions are conditional
ADDGT   R1, R0, #55       ; Convert 0xA -> 'A'
ADDLE   R1, R0, #48       ; Convert 0x0 -> '0'

IT      GT                ; IT block with only one conditional instruction
ADDGT   R1, R1, #1        ; Increment R1 conditionally

ITTEE   EQ                ; Next 4 instructions are conditional
MOVEQ   R0, R1            ; Conditional move
ADDEQ   R2, R2, #10       ; Conditional add
ANDNE   R3, R3, #1        ; Conditional AND
BNE.W   dloop            ; Branch instruction can only be used in the last
                          ; instruction of an IT block

IT      NE                ; Next instruction is conditional
ADD     R0, R0, R1        ; Syntax error: no condition code used in IT block
```

11.6.10.4 TBB and TBH

Table Branch Byte and Table Branch Halfword.

Syntax

```
TBB [Rn, Rm]
TBH [Rn, Rm, LSL #1]
```

where:

Rn is the register containing the address of the table of branch lengths.
If *Rn* is PC, then the address of the table is the address of the byte immediately following the TBB or TBH instruction.

Rm is the index register. This contains an index into the table. For halfword tables, LSL #1 doubles the value in *Rm* to form the right offset into the table.

Operation

These instructions cause a PC-relative forward branch using a table of single byte offsets for TBB, or halfword offsets for TBH. *Rn* provides a pointer to the table, and *Rm* supplies an index into the table. For TBB the branch offset is twice the unsigned value of the byte returned from the table. and for TBH the branch offset is twice the unsigned value of the halfword returned from the table. The branch occurs to the address at that offset from the address of the byte immediately after the TBB or TBH instruction.

Restrictions

The restrictions are:

- *Rn* must not be SP
- *Rm* must not be SP and must not be PC
- when any of these instructions is used inside an IT block, it must be the last instruction of the IT block.

Condition Flags

These instructions do not change the flags.

Examples

```
ADR.W R0, BranchTable_Byte
TBB [R0, R1] ; R1 is the index, R0 is the base address of the
; branch table

Case1
; an instruction sequence follows
Case2
; an instruction sequence follows
Case3
; an instruction sequence follows
BranchTable_Byte
DCB 0 ; Case1 offset calculation
DCB ((Case2-Case1)/2) ; Case2 offset calculation
DCB ((Case3-Case1)/2) ; Case3 offset calculation
TBH [PC, R1, LSL #1] ; R1 is the index, PC is used as base of the
; branch table

BranchTable_H
DCI ((CaseA - BranchTable_H)/2) ; CaseA offset calculation
DCI ((CaseB - BranchTable_H)/2) ; CaseB offset calculation
```

```

DCI      ((CaseC - BranchTable_H)/2) ; CaseC offset calculation
CaseA
; an instruction sequence follows
CaseB
; an instruction sequence follows
CaseC
; an instruction sequence follows

```

11.6.11 Miscellaneous Instructions

The table below shows the remaining Cortex-M4 instructions:

Table 11-27. Miscellaneous Instructions

Mnemonic	Description
BKPT	Breakpoint
CPSID	Change Processor State, Disable Interrupts
CPSIE	Change Processor State, Enable Interrupts
DMB	Data Memory Barrier
DSB	Data Synchronization Barrier
ISB	Instruction Synchronization Barrier
MRS	Move from special register to register
MSR	Move from register to special register
NOP	No Operation
SEV	Send Event
SVC	Supervisor Call
WFE	Wait For Event
WFI	Wait For Interrupt

11.6.11.1 BKPT

Breakpoint.

Syntax

```
BKPT #imm
```

where:

imm is an expression evaluating to an integer in the range 0-255 (8-bit value).

Operation

The BKPT instruction causes the processor to enter Debug state. Debug tools can use this to investigate system state when the instruction at a particular address is reached.

imm is ignored by the processor. If required, a debugger can use it to store additional information about the breakpoint.

The BKPT instruction can be placed inside an IT block, but it executes unconditionally, unaffected by the condition specified by the IT instruction.

Condition Flags

This instruction does not change the flags.

Examples

```
BKPT 0xAB ; Breakpoint with immediate value set to 0xAB (debugger can
; extract the immediate value by locating it using the PC)
```

Note: ARM does not recommend the use of the BKPT instruction with an immediate value set to 0xAB for any purpose other than Semi-hosting.

11.6.11.2 CPS

Change Processor State.

Syntax

```
CPSeffect iflags
```

where:

effect is one of:

IE Clears the special purpose register.

ID Sets the special purpose register.

iflags is a sequence of one or more flags:

i Set or clear PRIMASK.

f Set or clear FAULTMASK.

Operation

CPS changes the PRIMASK and FAULTMASK special register values. See [“Exception Mask Registers”](#) for more information about these registers.

Restrictions

The restrictions are:

- use CPS only from privileged software, it has no effect if used in unprivileged software
- CPS cannot be conditional and so must not be used inside an IT block.

Condition Flags

This instruction does not change the condition flags.

Examples

```
CPSID i ; Disable interrupts and configurable fault handlers (set PRIMASK)
CPSID f ; Disable interrupts and all fault handlers (set FAULTMASK)
CPSIE i ; Enable interrupts and configurable fault handlers (clear PRIMASK)
CPSIE f ; Enable interrupts and fault handlers (clear FAULTMASK)
```

11.6.11.3 DMB

Data Memory Barrier.

Syntax

```
DMB{cond}
```

where:

cond is an optional condition code, see [“Conditional Execution”](#).

Operation

DMB acts as a data memory barrier. It ensures that all explicit memory accesses that appear, in program order, before the DMB instruction are completed before any explicit memory accesses that appear, in program order, after the DMB instruction. DMB does not affect the ordering or execution of instructions that do not access memory.

Condition Flags

This instruction does not change the flags.

Examples

```
DMB ; Data Memory Barrier
```

11.6.11.4 DSB

Data Synchronization Barrier.

Syntax

```
DSB{cond}
```

where:

cond is an optional condition code, see [“Conditional Execution”](#).

Operation

DSB acts as a special data synchronization memory barrier. Instructions that come after the DSB, in program order, do not execute until the DSB instruction completes. The DSB instruction completes when all explicit memory accesses before it complete.

Condition Flags

This instruction does not change the flags.

Examples

```
DSB ; Data Synchronisation Barrier
```

11.6.11.5 ISB

Instruction Synchronization Barrier.

Syntax

```
ISB{cond}
```

where:

cond is an optional condition code, see [“Conditional Execution”](#).

Operation

ISB acts as an instruction synchronization barrier. It flushes the pipeline of the processor, so that all instructions following the ISB are fetched from memory again, after the ISB instruction has been completed.

Condition Flags

This instruction does not change the flags.

Examples

```
ISB ; Instruction Synchronisation Barrier
```

11.6.11.6 MRS

Move the contents of a special register to a general-purpose register.

Syntax

```
MRS{cond} Rd, spec_reg
```

where:

cond is an optional condition code, see “[Conditional Execution](#)” .

Rd is the destination register.

spec_reg can be any of: APSR, IPSR, EPSR, IEPSR, IAPSR, EAPSR, PSR, MSP, PSP, PRIMASK, BASEPRI, BASEPRI_MAX, FAULTMASK, or CONTROL.

Operation

Use MRS in combination with MSR as part of a read-modify-write sequence for updating a PSR, for example to clear the Q flag.

In process swap code, the programmers model state of the process being swapped out must be saved, including relevant PSR contents. Similarly, the state of the process being swapped in must also be restored. These operations use MRS in the state-saving instruction sequence and MSR in the state-restoring instruction sequence.

Note: BASEPRI_MAX is an alias of BASEPRI when used with the MRS instruction.

See “[MSR](#)” .

Restrictions

Rd must not be SP and must not be PC.

Condition Flags

This instruction does not change the flags.

Examples

```
MRS R0, PRIMASK ; Read PRIMASK value and write it to R0
```

11.6.11.7 MSR

Move the contents of a general-purpose register into the specified special register.

Syntax

```
MSR{cond} spec_reg, Rn
```

where:

cond is an optional condition code, see [“Conditional Execution”](#) .

Rn is the source register.

spec_reg can be any of: APSR, IPSR, EPSR, IEPSR, IAPSR, EAPSR, PSR, MSP, PSP, PRIMASK, BASEPRI, BASEPRI_MAX, FAULTMASK, or CONTROL.

Operation

The register access operation in MSR depends on the privilege level. Unprivileged software can only access the APSR. See [“Application Program Status Register”](#) . Privileged software can access all special registers.

In unprivileged software writes to unallocated or execution state bits in the PSR are ignored.

Note: When the user writes to BASEPRI_MAX, the instruction writes to BASEPRI only if either:
Rn is non-zero and the current BASEPRI value is 0
Rn is non-zero and less than the current BASEPRI value.

See [“MRS”](#) .

Restrictions

Rn must not be SP and must not be PC.

Condition Flags

This instruction updates the flags explicitly based on the value in *Rn*.

Examples

```
MSR CONTROL, R1 ; Read R1 value and write it to the CONTROL register
```

11.6.11.8 NOP

No Operation.

Syntax

```
NOP{cond}
```

where:

cond is an optional condition code, see [“Conditional Execution”](#) .

Operation

NOP does nothing. NOP is not necessarily a time-consuming NOP. The processor might remove it from the pipeline before it reaches the execution stage.

Use NOP for padding, for example to place the following instruction on a 64-bit boundary.

Condition Flags

This instruction does not change the flags.

Examples

```
NOP ; No operation
```

11.6.11.9 SEV

Send Event.

Syntax

```
SEV{cond}
```

where:

cond is an optional condition code, see [“Conditional Execution”](#) .

Operation

SEV is a hint instruction that causes an event to be signaled to all processors within a multiprocessor system. It also sets the local event register to 1, see [“Power Management”](#) .

Condition Flags

This instruction does not change the flags.

Examples

```
SEV ; Send Event
```

11.6.11.10 SVC

Supervisor Call.

Syntax

```
SVC{cond} #imm
```

where:

cond is an optional condition code, see [“Conditional Execution”](#).

imm is an expression evaluating to an integer in the range 0-255 (8-bit value).

Operation

The SVC instruction causes the SVC exception.

imm is ignored by the processor. If required, it can be retrieved by the exception handler to determine what service is being requested.

Condition Flags

This instruction does not change the flags.

Examples

```
SVC 0x32 ; Supervisor Call (SVC handler can extract the immediate value  
; by locating it via the stacked PC)
```

11.6.11.11 WFE

Wait For Event.

Syntax

```
WFE{cond}
```

where:

cond is an optional condition code, see [“Conditional Execution”](#) .

Operation

WFE is a hint instruction.

If the event register is 0, WFE suspends execution until one of the following events occurs:

- an exception, unless masked by the exception mask registers or the current priority level
- an exception enters the Pending state, if SEVONPEND in the System Control Register is set
- a Debug Entry request, if Debug is enabled
- an event signaled by a peripheral or another processor in a multiprocessor system using the SEV instruction.

If the event register is 1, WFE clears it to 0 and returns immediately.

For more information, see [“Power Management”](#) .

Condition Flags

This instruction does not change the flags.

Examples

```
WFE ; Wait for event
```

11.6.11.12 WFI

Wait for Interrupt.

Syntax

```
WFI{cond}
```

where:

cond is an optional condition code, see [“Conditional Execution”](#) .

Operation

WFI is a hint instruction that suspends execution until one of the following events occurs:

- an exception
- a Debug Entry request, regardless of whether Debug is enabled.

Condition Flags

This instruction does not change the flags.

Examples

```
WFI ; Wait for interrupt
```

11.7 Cortex-M4 Core Peripherals

11.7.1 Peripherals

- **Nested Vectored Interrupt Controller (NVIC)**
The Nested Vectored Interrupt Controller (NVIC) is an embedded interrupt controller that supports low latency interrupt processing. See [Section 11.8 "Nested Vectored Interrupt Controller \(NVIC\)"](#)
- **System Control Block (SCB)**
The System Control Block (SCB) is the programmers model interface to the processor. It provides system implementation information and system control, including configuration, control, and reporting of system exceptions. See [Section 11.9 "System Control Block \(SCB\)"](#)
- **System Timer (SysTick)**
The System Timer, SysTick, is a 24-bit count-down timer. Use this as a Real Time Operating System (RTOS) tick timer or as a simple counter. See [Section 11.10 "System Timer \(SysTick\)"](#)
- **Memory Protection Unit (MPU)**
The Memory Protection Unit (MPU) improves system reliability by defining the memory attributes for different memory regions. It provides up to eight different regions, and an optional predefined background region. See [Section 11.11 "Memory Protection Unit \(MPU\)"](#)

11.7.2 Address Map

The address map of the *Private peripheral bus* (PPB) is:

Core Peripheral Register Regions

Address	Core Peripheral
0xE000E008-0xE000E00F	System Control Block
0xE000E010-0xE000E01F	System Timer
0xE000E100-0xE000E4EF	Nested Vectored Interrupt Controller
0xE000ED00-0xE000ED3F	System control block
0xE000ED90-0xE000EDB8	Memory Protection Unit
0xE000EF00-0xE000EF03	Nested Vectored Interrupt Controller

In register descriptions:

- the *required privilege* gives the privilege level required to access the register, as follows:
 - Privileged: Only privileged software can access the register.
 - Unprivileged: Both unprivileged and privileged software can access the register.

11.8 Nested Vectored Interrupt Controller (NVIC)

This section describes the NVIC and the registers it uses. The NVIC supports:

- 1 to 35 interrupts.
- A programmable priority level of 0-15 for each interrupt. A higher level corresponds to a lower priority, so level 0 is the highest interrupt priority.
- Level detection of interrupt signals.
- Dynamic reprioritization of interrupts.
- Grouping of priority values into group priority and subpriority fields.
- Interrupt tail-chaining.
- An external *Non-maskable interrupt* (NMI)

The processor automatically stacks its state on exception entry and unstacks this state on exception exit, with no instruction overhead. This provides low latency exception handling.

11.8.1 Level-sensitive Interrupts

The processor supports level-sensitive interrupts. A level-sensitive interrupt is held asserted until the peripheral deasserts the interrupt signal. Typically, this happens because the ISR accesses the peripheral, causing it to clear the interrupt request.

When the processor enters the ISR, it automatically removes the pending state from the interrupt (see [“Hardware and Software Control of Interrupts”](#)). For a level-sensitive interrupt, if the signal is not deasserted before the processor returns from the ISR, the interrupt becomes pending again, and the processor must execute its ISR again. This means that the peripheral can hold the interrupt signal asserted until it no longer requires servicing.

11.8.1.1 *Hardware and Software Control of Interrupts*

The Cortex-M4 latches all interrupts. A peripheral interrupt becomes pending for one of the following reasons:

- The NVIC detects that the interrupt signal is HIGH and the interrupt is not active
- The NVIC detects a rising edge on the interrupt signal
- A software writes to the corresponding interrupt set-pending register bit, see [“Interrupt Set-pending Registers”](#), or to the NVIC_STIR register to make an interrupt pending, see [“Software Trigger Interrupt Register”](#).

A pending interrupt remains pending until one of the following:

- The processor enters the ISR for the interrupt. This changes the state of the interrupt from pending to active. Then:
 - For a level-sensitive interrupt, when the processor returns from the ISR, the NVIC samples the interrupt signal. If the signal is asserted, the state of the interrupt changes to pending, which might cause the processor to immediately re-enter the ISR. Otherwise, the state of the interrupt changes to inactive.
- Software writes to the corresponding interrupt clear-pending register bit.
For a level-sensitive interrupt, if the interrupt signal is still asserted, the state of the interrupt does not change. Otherwise, the state of the interrupt changes to inactive.

11.8.2 NVIC Design Hints and Tips

Ensure that the software uses correctly aligned register accesses. The processor does not support unaligned accesses to NVIC registers. See the individual register descriptions for the supported access sizes.

A interrupt can enter a pending state even if it is disabled. Disabling an interrupt only prevents the processor from taking that interrupt.

Before programming SCB_VTOR to relocate the vector table, ensure that the vector table entries of the new vector table are set up for fault handlers, NMI and all enabled exception like interrupts. For more information, see the “[Vector Table Offset Register](#)” .

11.8.2.1 NVIC Programming Hints

The software uses the CPSIE I and CPSID I instructions to enable and disable the interrupts. The CMSIS provides the following intrinsic functions for these instructions:

```
void __disable_irq(void) // Disable Interrupts
void __enable_irq(void) // Enable Interrupts
```

In addition, the CMSIS provides a number of functions for NVIC control, including:

Table 11-28. CMSIS Functions for NVIC Control

CMSIS Interrupt Control Function	Description
void NVIC_SetPriorityGrouping(uint32_t priority_grouping)	Set the priority grouping
void NVIC_EnableIRQ(IRQn_t IRQn)	Enable IRQn
void NVIC_DisableIRQ(IRQn_t IRQn)	Disable IRQn
uint32_t NVIC_GetPendingIRQ (IRQn_t IRQn)	Return true (IRQ-Number) if IRQn is pending
void NVIC_SetPendingIRQ (IRQn_t IRQn)	Set IRQn pending
void NVIC_ClearPendingIRQ (IRQn_t IRQn)	Clear IRQn pending status
uint32_t NVIC_GetActive (IRQn_t IRQn)	Return the IRQ number of the active interrupt
void NVIC_SetPriority (IRQn_t IRQn, uint32_t priority)	Set priority for IRQn
uint32_t NVIC_GetPriority (IRQn_t IRQn)	Read priority of IRQn
void NVIC_SystemReset (void)	Reset the system

The input parameter IRQn is the IRQ number. For more information about these functions, see the CMSIS documentation.

To improve software efficiency, the CMSIS simplifies the NVIC register presentation. In the CMSIS:

- the Set-enable, Clear-enable, Set-pending, Clear-pending and Active Bit registers map to arrays of 32-bit integers, so that:
 - the array ISER[0] to ISER[1] corresponds to the registers ISER0-ISER1
 - the array ICER[0] to ICER[1] corresponds to the registers ICER0-ICER1
 - the array ISPR[0] to ISPR[1] corresponds to the registers ISPR0-ISPR1
 - the array ICPR[0] to ICPR[1] corresponds to the registers ICPR0-ICPR1
 - the array IABR[0]to IABR[1] corresponds to the registers IABR0-IABR1

- the 4-bit fields of the Interrupt Priority Registers map to an array of 4-bit integers, so that the array IP[0] to IP[34] corresponds to the registers IPR0-IPR8, and the array entry IP[*n*] holds the interrupt priority for interrupt *n*.

The CMSIS provides thread-safe code that gives atomic access to the Interrupt Priority Registers. Table 11-29 shows how the interrupts, or IRQ numbers, map onto the interrupt registers and corresponding CMSIS variables that have one bit per interrupt.

Table 11-29. Mapping of interrupts to the interrupt variables

Interrupts	CMSIS Array Elements ⁽¹⁾				
	Set-enable	Clear-enable	Set-pending	Clear-pending	Active Bit
0-34	ISER[0]	ICER[0]	ISPR[0]	ICPR[0]	IABR[0]
35-63	ISER[1]	ICER[1]	ISPR[1]	ICPR[1]	IABR[1]

Note: 1. Each array element corresponds to a single NVIC register, for example the element ICER[0] corresponds to the ICER0 register.

11.8.3 Nested Vectored Interrupt Controller (NVIC) User Interface

Table 11-30. Nested Vectored Interrupt Controller (NVIC) Register Mapping

Offset	Register	Name	Access	Reset
0xE000E100	Interrupt Set-enable Register 0	NVIC_ISER0	Read-write	0x00000000
...
0xE000E11C	Interrupt Set-enable Register 7	NVIC_ISER7	Read-write	0x00000000
0xE000E180	Interrupt Clear-enable Register 0	NVIC_ICER0	Read-write	0x00000000
...
0xE000E19C	Interrupt Clear-enable Register 7	NVIC_ICER7	Read-write	0x00000000
0xE000E200	Interrupt Set-pending Register 0	NVIC_ISPR0	Read-write	0x00000000
...
0xE000E21C	Interrupt Set-pending Register 7	NVIC_ISPR7	Read-write	0x00000000
0xE000E280	Interrupt Clear-pending Register 0	NVIC_ICPR0	Read-write	0x00000000
...
0xE000E29C	Interrupt Clear-pending Register 7	NVIC_ICPR7	Read-write	0x00000000
0xE000E300	Interrupt Active Bit Register 0	NVIC_IABR0	Read-write	0x00000000
...
0xE000E31C	Interrupt Active Bit Register 7	NVIC_IABR7	Read-write	0x00000000
0xE000E400	Interrupt Priority Register 0	NVIC_IPR0	Read-write	0x00000000
...
0xE000E4EF	Interrupt Priority Register 8	NVIC_IPR8	Read-write	0x00000000
0xE000EF00	Software Trigger Interrupt Register	NVIC_STIR	Write-only	0x00000000

11.8.3.1 Interrupt Set-enable Registers

Name: NVIC_ISERx [x=0..7]

Access: Read-write

Reset: 0x00000000

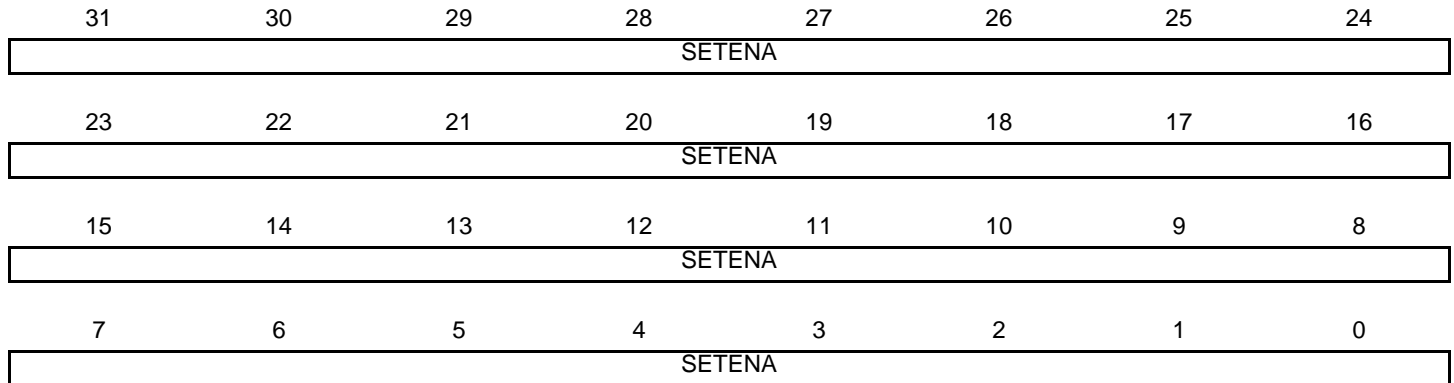

These registers enable interrupts, and show which interrupts are enabled.

- **SETENA: Interrupt Set-enable**

Write:

0: No effect.

1: Enables the interrupt.

Read:

0: Interrupt disabled.

1: Interrupt enabled.

- Notes:
1. If a pending interrupt is enabled, the NVIC activates the interrupt based on its priority.
 2. If an interrupt is not enabled, asserting its interrupt signal changes the interrupt state to pending, the NVIC never activates the interrupt, regardless of its priority.

11.8.3.2 Interrupt Clear-enable Registers

Name: NVIC_ICERx [x=0..7]

Access: Read-write

Reset: 0x00000000

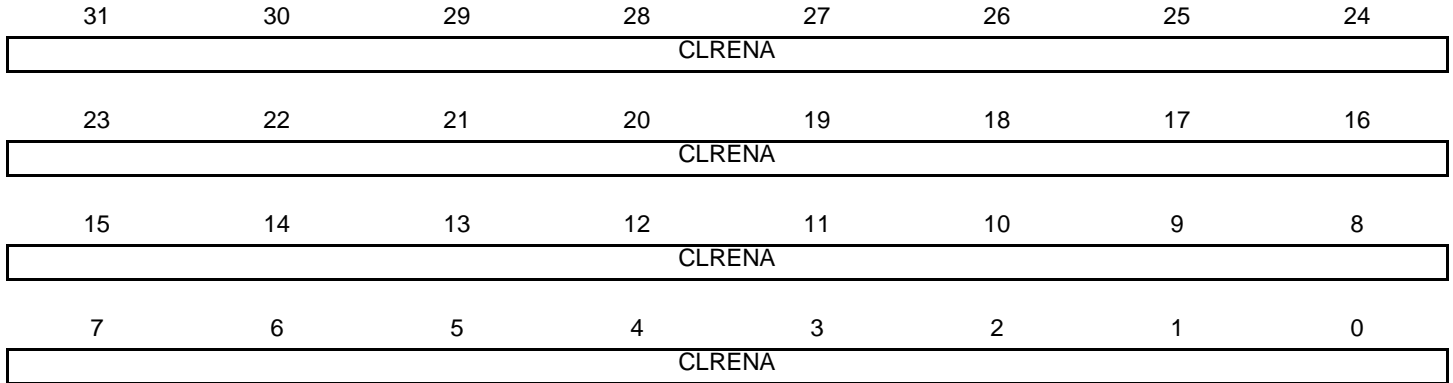

These registers disable interrupts, and show which interrupts are enabled.

- **CLRENA: Interrupt Set-enable**

Write:

0: No effect.

1: Disables the interrupt.

Read:

0: Interrupt disabled.

1: Interrupt enabled.

11.8.3.3 Interrupt Set-pending Registers

Name: NVIC_ISPRx [x=0..7]

Access: Read-write

Reset: 0x00000000

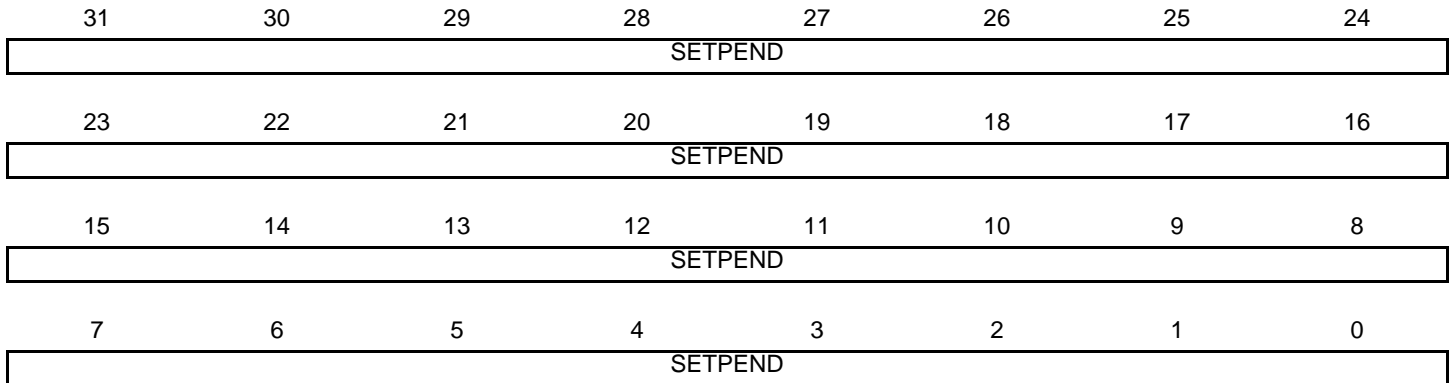

These registers force interrupts into the pending state, and show which interrupts are pending.

- **SETPEND: Interrupt Set-pending**

Write:

0: No effect.

1: Changes the interrupt state to pending.

Read:

0: Interrupt is not pending.

1: Interrupt is pending.

- Notes:
1. Writing 1 to an ISPR bit corresponding to an interrupt that is pending has no effect.
 2. Writing 1 to an ISPR bit corresponding to a disabled interrupt sets the state of that interrupt to pending.

11.8.3.4 Interrupt Clear-pending Registers

Name: NVIC_ICPRx [x=0..7]

Access: Read-write

Reset: 0x00000000

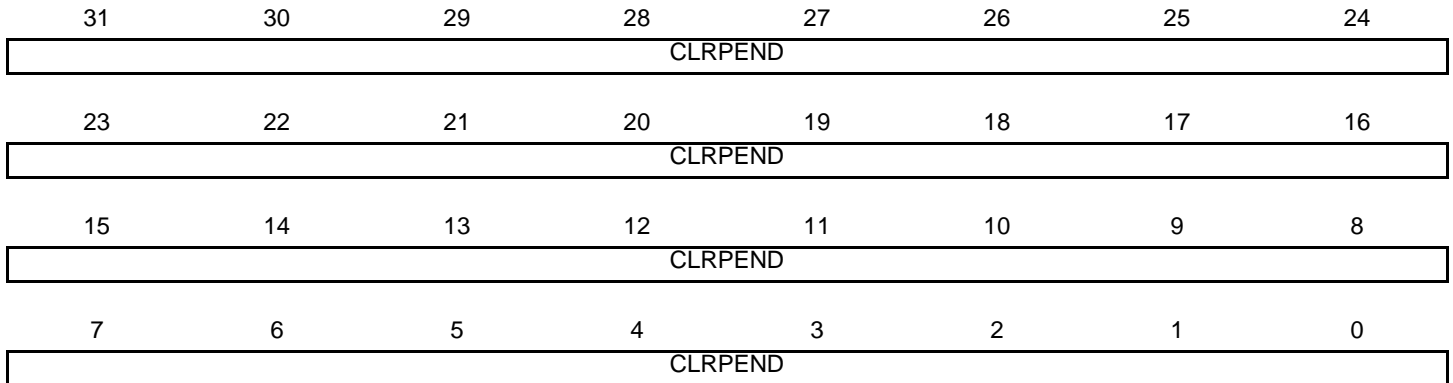

These registers remove the pending state from interrupts, and show which interrupts are pending.

- **CLRPEND: Interrupt Clear-pending**

Write:

0: No effect.

1: removes the pending state from an interrupt.

Read:

0: Interrupt is not pending.

1: Interrupt is pending.

Note: Writing 1 to an ICPR bit does not affect the active state of the corresponding interrupt.

11.8.3.5 Interrupt Active Bit Registers

Name: NVIC_IABRx [x=0..7]

Access: Read-write

Reset: 0x00000000

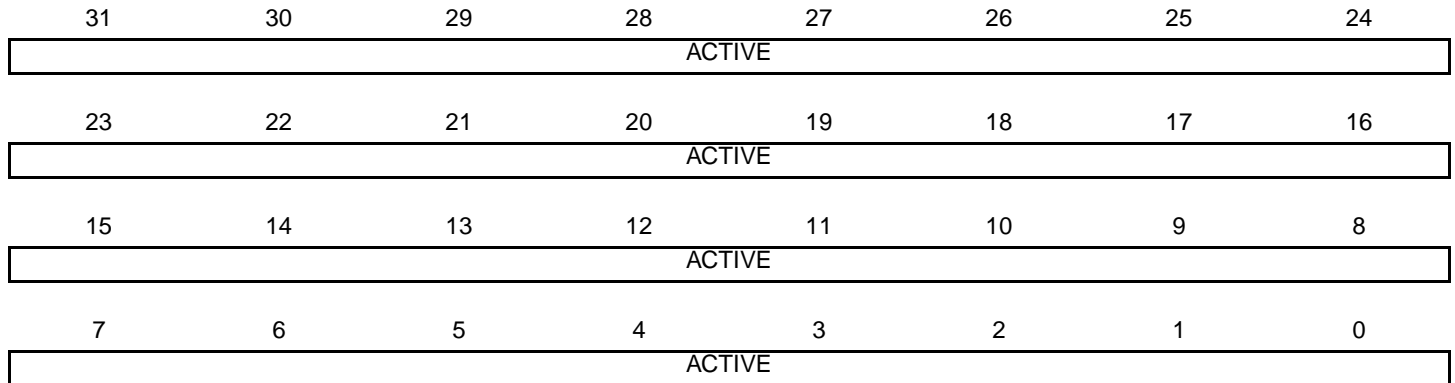

These registers indicate which interrupts are active.

- **ACTIVE: Interrupt Active Flags**

0: Interrupt is not active.

1: Interrupt is active.

Note: A bit reads as one if the status of the corresponding interrupt is active, or active and pending.

11.8.3.6 Interrupt Priority Registers

Name: NVIC_IPRx [x=0..8]

Access: Read-write

Reset: 0x00000000

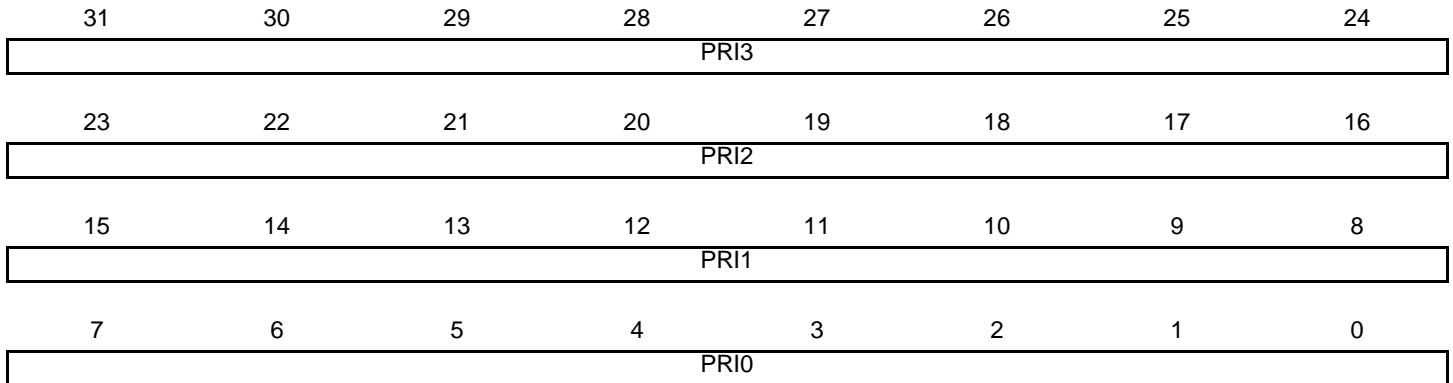

The NVIC_IPR0-NVIC_IPR8 registers provide a 4-bit priority field for each interrupt. These registers are byte-accessible. Each register holds four priority fields, that map up to four elements in the CMSIS interrupt priority array IP[0] to IP[34]

- **PRI3: Priority (4m+3)**

Priority, Byte Offset 3, refers to register bits [31:24].

- **PRI2: Priority (4m+2)**

Priority, Byte Offset 2, refers to register bits [23:16].

- **PRI1: Priority (4m+1)**

Priority, Byte Offset 1, refers to register bits [15:8].

- **PRI0: Priority (4m)**

Priority, Byte Offset 0, refers to register bits [7:0].

- Notes:
1. Each priority field holds a priority value, 0-15. The lower the value, the greater the priority of the corresponding interrupt. The processor implements only bits[7:4] of each field; bits[3:0] read as zero and ignore writes.
 2. for more information about the IP[0] to IP[34] interrupt priority array, that provides the software view of the interrupt priorities, see [Table 11-28, "CMSIS Functions for NVIC Control"](#) .
 3. The corresponding IPR number n is given by $n = m \text{ DIV } 4$.
 4. The byte offset of the required Priority field in this register is $m \text{ MOD } 4$.

11.8.3.7 Software Trigger Interrupt Register

Name: NVIC_STIR

Access: Write-only

Reset: 0x00000000

31	30	29	28	27	26	25	24
–	–	–	–	–	–	–	–
23	22	21	20	19	18	17	16
–	–	–	–	–	–	–	–
15	14	13	12	11	10	9	8
–	–	–	–	–	–	–	INTID
7	6	5	4	3	2	1	0
INTID							

Write to this register to generate an interrupt from software.

- **INTID: Interrupt ID**

Interrupt ID of the interrupt to trigger, in the range 0-239. For example, a value of 0x03 specifies interrupt IRQ3.

11.9 System Control Block (SCB)

The System Control Block (SCB) provides system implementation information, and system control. This includes configuration, control, and reporting of the system exceptions.

Ensure that the software uses aligned accesses of the correct size to access the system control block registers:

- except for the SCB_CFSR and SCB_SHPR1-SCB_SHPR3 registers, it must use aligned word accesses
- for the SCB_CFSR and SCB_SHPR1-SCB_SHPR3 registers, it can use byte or aligned halfword or word accesses.

The processor does not support unaligned accesses to system control block registers.

In a fault handler, to determine the true faulting address:

1. Read and save the MMFAR or SCB_BFAR value.
2. Read the MMARVALID bit in the MMFSR subregister, or the BFARVALID bit in the BFSR subregister. The SCB_MMFAR or SCB_BFAR address is valid only if this bit is 1.

The software must follow this sequence because another higher priority exception might change the SCB_MMFAR or SCB_BFAR value. For example, if a higher priority handler preempts the current fault handler, the other fault might change the SCB_MMFAR or SCB_BFAR value.

11.9.1 System Control Block (SCB) User Interface

Table 11-31. System Control Block (SCB) Register Mapping

Offset	Register	Name	Access	Reset
0xE000E008	Auxiliary Control Register	SCB_ACTLR	Read-write	0x00000000
0xE000ED00	CPUID Base Register	SCB_CPUID	Read-only	0x410FC240
0xE000ED04	Interrupt Control and State Register	SCB_ICSR	Read-write ⁽¹⁾	0x00000000
0xE000ED08	Vector Table Offset Register	SCB_VTOR	Read-write	0x00000000
0xE000ED0C	Application Interrupt and Reset Control Register	SCB_AIRCR	Read-write	0xFA050000
0xE000ED10	System Control Register	SCB_SCR	Read-write	0x00000000
0xE000ED14	Configuration and Control Register	SCB_CCR	Read-write	0x00000200
0xE000ED18	System Handler Priority Register 1	SCB_SHPR1	Read-write	0x00000000
0xE000ED1C	System Handler Priority Register 2	SCB_SHPR2	Read-write	0x00000000
0xE000ED20	System Handler Priority Register 3	SCB_SHPR3	Read-write	0x00000000
0xE000ED24	System Handler Control and State Register	SCB_SHCSR	Read-write	0x00000000
0xE000ED28	Configurable Fault Status Register	SCB_CFSR	Read-write	0x00000000
0xE000ED28	MemManage Fault Status Register	MMFSR ⁽²⁾	Read-write	0x00
0xE000ED29	BusFault Status Register	BFSR ⁽²⁾	Read-write	0x00
0xE000ED2A	UsageFault Status Register	UFSR ⁽²⁾	Read-write	0x0000
0xE000ED2C	HardFault Status Register	SCB_HFSR	Read-write	0x00000000
0xE000ED34	MemManage Fault Address Register	SCB_MMFAR	Read-write	Unknown
0xE000ED38	BusFault Address Register	SCB_BFAR	Read-write	Unknown
0xE000ED3C	Auxiliary Fault Status Register	SCB_AFSR	Read-write	0x00000000

Notes: 1. See the register description for more information.

2. A subregister of SCB_CFSR

11.9.1.1 Auxiliary Control Register

Name: SCB_ACTLR

Access: Read-write

Reset: 0x00000000

31	30	29	28	27	26	25	24
-							
23	22	21	20	19	18	17	16
-							
15	14	13	12	11	10	9	8
-						DISOFP	DISFPCA
7	6	5	4	3	2	1	0
-					DISFOLD	DISDEFWBUF	DISMCYCINT

The SCB_ACTLR register provides disable bits for the following processor functions:

- IT folding
- write buffer use for accesses to the default memory map
- interruption of multi-cycle instructions.

By default, this register is set to provide optimum performance from the Cortex-M4 processor, and does not normally require modification.

- **DISOFP: Disable Out Of Order Floating Point**

Disables floating point instructions that complete out of order with respect to integer instructions.

- **DISFPCA: Disable FPCA**

Disables an automatic update of CONTROL.FPCA.

- **DISFOLD: Disable Folding**

When set to 1, disables the IT folding.

Note: In some situations, the processor can start executing the first instruction in an IT block while it is still executing the IT instruction. This behavior is called IT folding, and it improves the performance. However, IT folding can cause jitter in looping. If a task must avoid jitter, set the DISFOLD bit to 1 before executing the task, to disable the IT folding.

- **DISDEFWBUF: Disable Default Write Buffer**

When set to 1, it disables the write buffer use during default memory map accesses. This causes BusFault to be precise but decreases the performance, as any store to memory must complete before the processor can execute the next instruction.

This bit only affects write buffers implemented in the Cortex-M4 processor.

- **DISMCYCINT: Disable Multiple Cycle Interruption**

When set to 1, it disables the interruption of load multiple and store multiple instructions. This increases the interrupt latency of the processor, as any LDM or STM must complete before the processor can stack the current state and enter the interrupt handler.

11.9.1.2 CPUID Base Register

Name: SCB_CPUID

Access: Read-write

Reset: 0x00000000

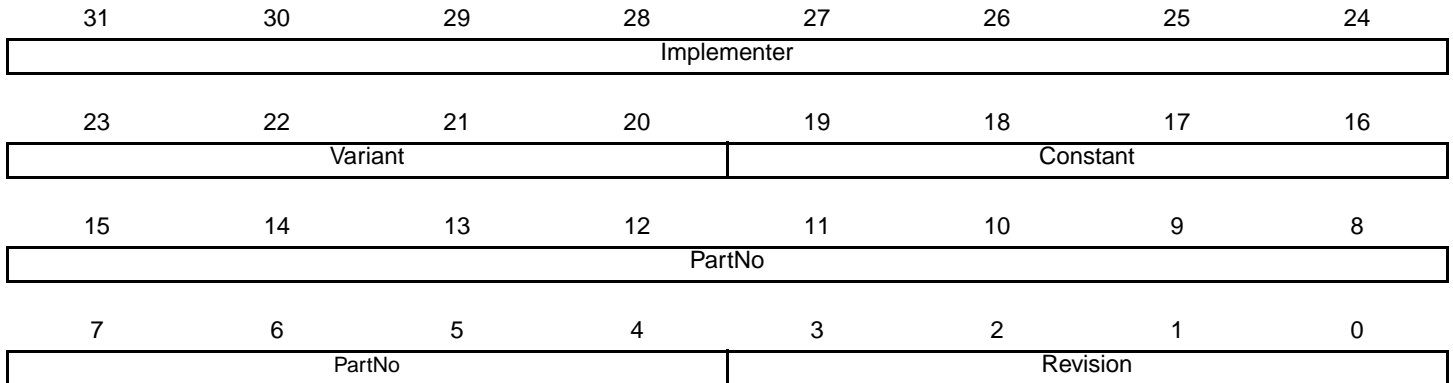

The SCB_CPUID register contains the processor part number, version, and implementation information.

- **Implementer: Implementer code**

0x41: ARM.

- **Variant: Variant number**

It is the r value in the rnpn product revision identifier:

0x0: Revision 0.

- **Constant**

Reads as 0xF.

- **PartNo: Part Number of the processor**

0xC24 = Cortex-M4.

- **Revision: Revision number**

It is the p value in the rnpn product revision identifier:

0x0: Patch 0.

11.9.1.3 Interrupt Control and State Register

Name: SCB_ICSR

Access: Read-write

Reset: 0x00000000

31	30	29	28	27	26	25	24
NMIPENDSET	–		PENDSVSET	PENDSVCLR	PENDSTSET	PENDSTCLR	–
23	22	21	20	19	18	17	16
–	ISR_PENDING	VECTPENDING					
15	14	13	12	11	10	9	8
VECTPENDING				RETTOBASE	–	VECTACTIVE	
7	6	5	4	3	2	1	0
VECTACTIVE							

The SCB_ICSR register provides a set-pending bit for the Non-Maskable Interrupt (NMI) exception, and set-pending and clear-pending bits for the PendSV and SysTick exceptions.

It indicates:

- the exception number of the exception being processed, and whether there are preempted active exceptions,
- the exception number of the highest priority pending exception, and whether any interrupts are pending.

• **NMIPENDSET: NMI Set-pending**

Write:

PendSV set-pending bit.

Write:

0: no effect.

1: changes NMI exception state to pending.

Read:

0: NMI exception is not pending.

1: NMI exception is pending.

As NMI is the highest-priority exception, the processor normally enters the NMI exception handler as soon as it registers a write of 1 to this bit. Entering the handler clears this bit to 0. A read of this bit by the NMI exception handler returns 1 only if the NMI signal is reasserted while the processor is executing that handler.

• **PENDSVSET: PendSV Set-pending**

Write:

0: no effect.

1: changes PendSV exception state to pending.

Read:

0: PendSV exception is not pending.

1: PendSV exception is pending.

Writing 1 to this bit is the only way to set the PendSV exception state to pending.

- **PENDSVCLR: PendSV Clear-pending**

Write:

0: no effect.

1: removes the pending state from the PendSV exception.

- **PENDSTSET: SysTick Exception Set-pending**

Write:

0: no effect.

1: changes SysTick exception state to pending.

Read:

0: SysTick exception is not pending.

1: SysTick exception is pending.

- **PENDSTCLR: SysTick Exception Clear-pending**

Write:

0: no effect.

1: removes the pending state from the SysTick exception.

This bit is Write-only. On a register read, its value is Unknown.

- **ISRPENDING: Interrupt Pending flag (excluding NMI and Faults)**

0: interrupt not pending.

1: interrupt pending.

- **VECTPENDING: Exception number of the highest priority pending enabled exception**

0: no pending exceptions.

Nonzero: the exception number of the highest priority pending enabled exception.

The value indicated by this field includes the effect of the BASEPRI and FAULTMASK registers, but not any effect of the PRIMASK register.

- **RETTOBASE: Preempted Active Exceptions present or not**

0: there are preempted active exceptions to execute.

1: there are no active exceptions, or the currently-executing exception is the only active exception.

- **VECTACTIVE: Active Exception Number contained**

0: Thread mode.

Nonzero: The exception number of the currently active exception. The value is the same as IPSR bits [8:0]. See [“Interrupt Program Status Register”](#) .

Subtract 16 from this value to obtain the IRQ number required to index into the Interrupt Clear-Enable, Set-Enable, Clear-Pending, Set-Pending, or Priority Registers, see [“Interrupt Program Status Register”](#) .

Note: When the user writes to the SCB_ICSR register, the effect is unpredictable if:

- writing 1 to the PENDSVSET bit and writing 1 to the PENDSVCLR bit
- writing 1 to the PENDSTSET bit and writing 1 to the PENDSTCLR bit.

11.9.1.4 Vector Table Offset Register

Name: SCB_VTOR

Access: Read-write

Reset: 0x00000000

31	30	29	28	27	26	25	24
TBLOFF							
23	22	21	20	19	18	17	16
TBLOFF							
15	14	13	12	11	10	9	8
TBLOFF							
7	6	5	4	3	2	1	0
TBLOFF							

The SCB_VTOR register indicates the offset of the vector table base address from memory address 0x00000000.

- **TBLOFF: Vector Table Base Offset**

It contains bits [29:7] of the offset of the table base from the bottom of the memory map.

Bit [29] determines whether the vector table is in the code or SRAM memory region:

0: Code.

1: SRAM.

It is sometimes called the TBLBASE bit.

Note: When setting TBLOFF, the offset must be aligned to the number of exception entries in the vector table. Configure the next statement to give the information required for your implementation; the statement reminds the user of how to determine the alignment requirement. The minimum alignment is 32 words, enough for up to 16 interrupts. For more interrupts, adjust the alignment by rounding up to the next power of two. For example, if 21 interrupts are required, the alignment must be on a 64-word boundary because the required table size is 37 words, and the next power of two is 64.

Table alignment requirements mean that bits[6:0] of the table offset are always zero.

11.9.1.5 Application Interrupt and Reset Control Register

Name: SCB_AIRCR

Access: Read-write

Reset: 0x00000000

	31	30	29	28	27	26	25	24	
VECTKEYSTAT/VECTKEY									
	23	22	21	20	19	18	17	16	
VECTKEYSTAT/VECTKEY									
	15	14	13	12	11	10	9	8	
ENDIANNESS	–					PRIGROUP			
	7	6	5	4	3	2	1	0	
–						SYSRESETREQ	VECTCLRACTI VE	VECTRESET	

The SCB_AIRCR register provides priority grouping control for the exception model, endian status for data accesses, and reset control of the system. To write to this register, write 0x5FA to the VECTKEY field, otherwise the processor ignores the write.

- **VECTKEYSTAT: Register Key**

Read:

Reads as 0xFA05.

- **VECTKEY: Register Key**

Write:

Writes 0x5FA to VECTKEY, otherwise the write is ignored.

- **ENDIANNESS: Data Endianness**

0: Little-endian.

1: Big-endian.

- **PRIGROUP: Interrupt Priority Grouping**

This field determines the split of group priority from subpriority. It shows the position of the binary point that splits the PRI_n fields in the Interrupt Priority Registers into separate *group priority* and *subpriority* fields. The table below shows how the PRIGROUP value controls this split:

PRIGROUP	Interrupt Priority Level Value, PRI _M [7:0]			Number of	
	Binary Point ⁽¹⁾	Group Priority bits	Subpriority bits	Group Priorities	Subpriorities
0b000	bxxxxxxx.y	[7:1]	None	128	2
0b001	bxxxxxx.yy	[7:2]	[4:0]	64	4
0b010	bxxxxx.yyy	[7:3]	[4:0]	32	8
0b011	bxxxx.yyyy	[7:4]	[4:0]	16	16
0b100	bxxx.yyyyy	[7:5]	[4:0]	8	32

PRIGROUP	Interrupt Priority Level Value, PRI_N[7:0]			Number of	
	Binary Point ⁽¹⁾	Group Priority bits	Subpriority bits	Group Priorities	Subpriorities
0b101	bxx.yyyyyy	[7:6]	[5:0]	4	64
0b110	bx.yyyyyyy	[7]	[6:0]	2	128
0b111	b.yyyyyyy	None	[7:0]	1	256

Note: 1. In the PRI_n[7:0] field showing the binary point, x denotes a group priority field bit, and y denotes a subpriority field bit. Determining preemption of an exception uses only the group priority field.

- **SYSRESETREQ: System Reset Request**

0: No system reset request.

1: Asserts a signal to the outer system that requests a reset.

This is intended to force a large system reset of all major components except for debug. This bit reads as 0.

- **VECTCLRACTIVE**

Reserved for Debug use. This bit reads as 0. When writing to the register, write 0 to this bit, otherwise the behavior is unpredictable.

- **VECTRESET**

Reserved for Debug use. This bit reads as 0. When writing to the register, write 0 to this bit, otherwise the behavior is unpredictable.



11.9.1.6 System Control Register

Name: SCB_SCR

Access: Read-write

Reset: 0x00000000

31	30	29	28	27	26	25	24
-							
23	22	21	20	19	18	17	16
-							
15	14	13	12	11	10	9	8
-							
7	6	5	4	3	2	1	0
	-		SEVONPEND	-	SLEEPDEEP	SLEEPONEXIT	-

• **SEVONPEND: Send Event on Pending bit**

0: only enabled interrupts or events can wake up the processor; disabled interrupts are excluded.

1: enabled events and all interrupts, including disabled interrupts, can wake up the processor.

When an event or an interrupt enters the pending state, the event signal wakes up the processor from WFE. If the processor is not waiting for an event, the event is registered and affects the next WFE.

The processor also wakes up on execution of an SEV instruction or an external event.

• **SLEEPDEEP: Sleep or Deep Sleep**

Controls whether the processor uses sleep or deep sleep as its low power mode:

0: sleep.

1: deep sleep.

• **SLEEPONEXIT: Sleep-on-exit**

Indicates sleep-on-exit when returning from the Handler mode to the Thread mode:

0: do not sleep when returning to Thread mode.

1: enter sleep, or deep sleep, on return from an ISR.

Setting this bit to 1 enables an interrupt-driven application to avoid returning to an empty main application.

11.9.1.7 Configuration and Control Register

Name: SCB_CCR
Access: Read-write
Reset: 0x00000000

31	30	29	28	27	26	25	24	
-								
23	22	21	20	19	18	17	16	
-								
15	14	13	12	11	10	9	8	
-						STKALIGN	BFHFNMIGN	
7	6	5	4	3	2	1	0	
-			DIV_0_TRP	UNALIGN_TRP	-		USERSETMPE ND	NONBASETHR DENA

The SCB_CCR register controls the entry to the Thread mode and enables the handlers for NMI, hard fault and faults escalated by FAULTMASK to ignore BusFaults. It also enables the division by zero and unaligned access trapping, and the access to the NVIC_STIR register by unprivileged software (see [“Software Trigger Interrupt Register”](#)).

- **STKALIGN: Stack Alignment**

Indicates the stack alignment on exception entry:

- 0: 4-byte aligned.
- 1: 8-byte aligned.

On exception entry, the processor uses bit [9] of the stacked PSR to indicate the stack alignment. On return from the exception, it uses this stacked bit to restore the correct stack alignment.

- **BFHFNMIGN: Bus Faults Ignored**

Enables handlers with priority -1 or -2 to ignore data bus faults caused by load and store instructions. This applies to the hard fault and FAULTMASK escalated handlers:

- 0: data bus faults caused by load and store instructions cause a lock-up.
- 1: handlers running at priority -1 and -2 ignore data bus faults caused by load and store instructions.

Set this bit to 1 only when the handler and its data are in absolutely safe memory. The normal use of this bit is to probe system devices and bridges to detect control path problems and fix them.

- **DIV_0_TRP: Division by Zero Trap**

Enables faulting or halting when the processor executes an SDIV or UDIV instruction with a divisor of 0:

- 0: do not trap divide by 0.
- 1: trap divide by 0.

When this bit is set to 0, a divide by zero returns a quotient of 0.

- **UNALIGN_TRP: Unaligned Access Trap**

Enables unaligned access traps:

0: do not trap unaligned halfword and word accesses.

1: trap unaligned halfword and word accesses.

If this bit is set to 1, an unaligned access generates a usage fault.

Unaligned LDM, STM, LDRD, and STRD instructions always fault irrespective of whether UNALIGN_TRP is set to 1.

- **USERSETMPEND**

Enables unprivileged software access to the NVIC_STIR register, see [“Software Trigger Interrupt Register”](#) :

0: disable.

1: enable.

- **NONEBASETHRDENA: Thread Mode Enable**

Indicates how the processor enters Thread mode:

0: the processor can enter the Thread mode only when no exception is active.

1: the processor can enter the Thread mode from any level under the control of an EXC_RETURN value, see [“Exception Return”](#) .

11.9.1.8 System Handler Priority Registers

The SCB_SHPR1-SCB_SHPR3 registers set the priority level, 0 to 15 of the exception handlers that have configurable priority. They are byte-accessible.

The system fault handlers and the priority field and register for each handler are:

Table 11-32. System Fault Handler Priority Fields

Handler	Field	Register Description
Memory management fault (MemManage)	PRI_4	"System Handler Priority Register 1"
Bus fault (BusFault)	PRI_5	
Usage fault (UsageFault)	PRI_6	
SVCall	PRI_11	"System Handler Priority Register 2"
PendSV	PRI_14	"System Handler Priority Register 3"
SysTick	PRI_15	

Each PRI_N field is 8 bits wide, but the processor implements only bits [7:4] of each field, and bits [3:0] read as zero and ignore writes.



11.9.1.9 System Handler Priority Register 1

Name: SCB_SHPR1

Access: Read-write

Reset: 0x00000000

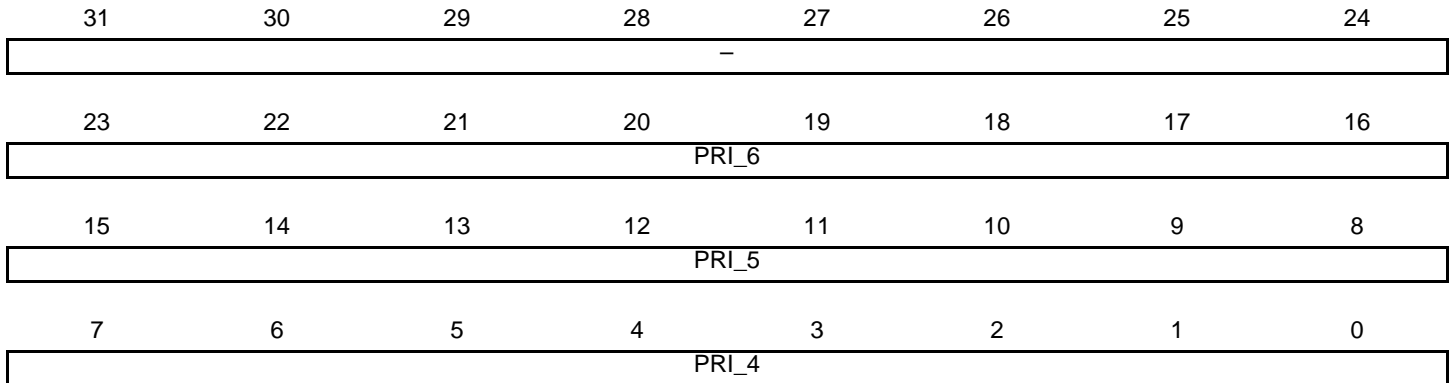

- **PRI_6: Priority**

Priority of system handler 6, UsageFault.

- **PRI_5: Priority**

Priority of system handler 5, BusFault.

- **PRI_4: Priority**

Priority of system handler 4, MemManage.

11.9.1.10 System Handler Priority Register 2

Name: SCB_SHPR2

Access: Read-write

Reset: 0x00000000

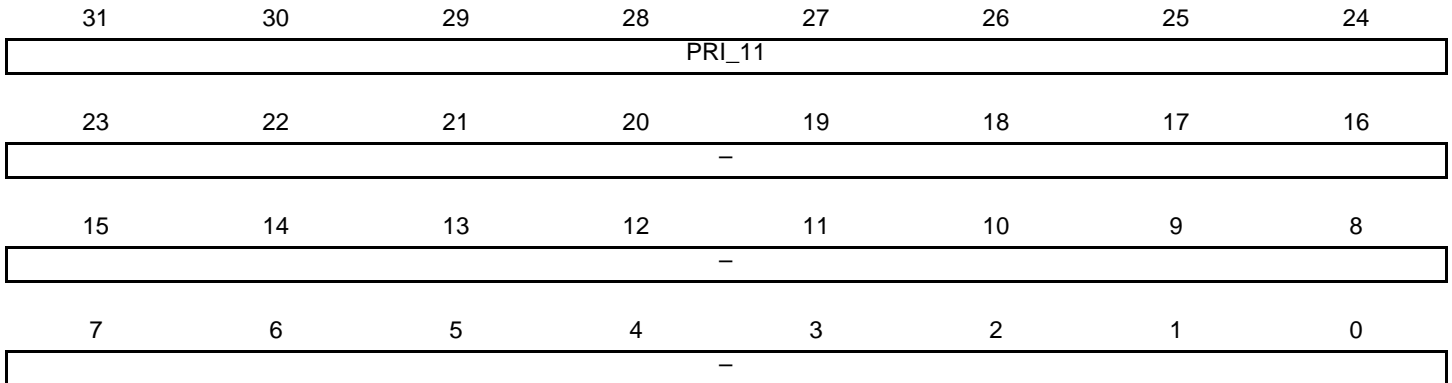

- **PRI_11: Priority**

Priority of system handler 11, SVCcall.

11.9.1.11 System Handler Priority Register 3

Name: SCB_SHPR3

Access: Read-write

Reset: 0x00000000

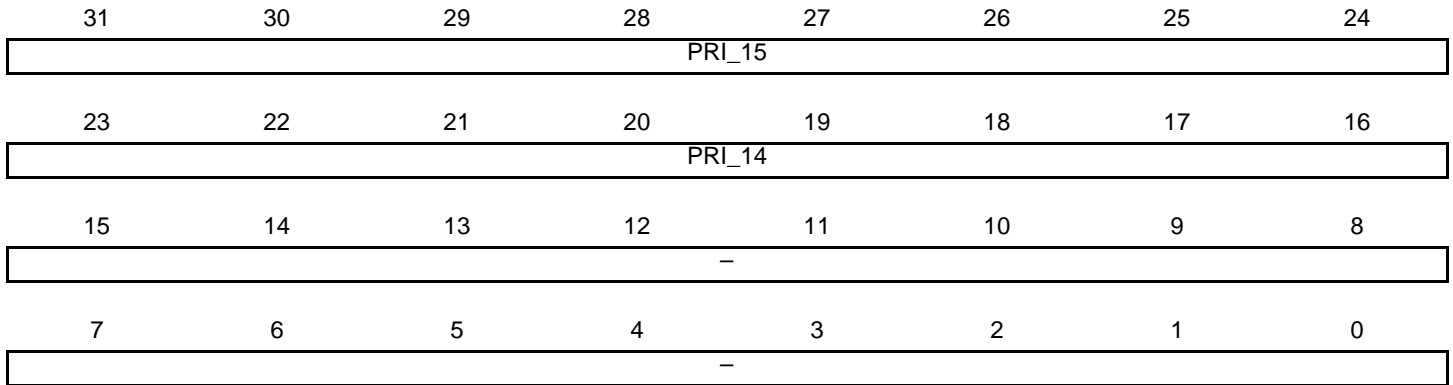

- **PRI_15: Priority**
Priority of system handler 15, SysTick exception.
- **PRI_14: Priority**
Priority of system handler 14, PendSV.

11.9.1.12 System Handler Control and State Register

Name: SCB_SHCSR

Access: Read-write

Reset: 0x00000000

31	30	29	28	27	26	25	24
23	22	21	20	19	18	17	16
					USGFAULTENA	BUSFAULTENA	MEMFAULTENA
15	14	13	12	11	10	9	8
SVCALLPENDE D	BUSFAULTPEN DED	MEMFAULTPEN DED	USGFAULTPEN DED	SYSTICKACT	PENDSVACT	–	MONITORACT
7	6	5	4	3	2	1	0
SVCALLAVCT				USGFAULTACT	–	BUSFAULTACT	MEMFAULTACT

The SHCSR register enables the system handlers, and indicates the pending status of the bus fault, memory management fault, and SVC exceptions; it also indicates the active status of the system handlers.

- **USGFAULTENA: Usage Fault Enable**

0: Disables the exception.

1: Enables the exception.

- **BUSFAULTENA: Bus Fault Enable**

0: Disables the exception.

1: Enables the exception.

- **MEMFAULTENA: Memory Management Fault Enable**

0: Disables the exception.

1: Enables the exception.

- **SVCALLPENDEDED: SVC Call Pending**

Read:

0: The exception is not pending.

1: The exception is pending.

The user can write to these bits to change the pending status of the exceptions.

- **BUSFAULTPENDEDED: Bus Fault Exception Pending**

Read:

0: The exception is not pending.

1: The exception is pending.

Note: The user can write to these bits to change the pending status of the exceptions.

- **MEMFAULTPENDEDED: Memory Management Fault Exception Pending**

Read:

0: The exception is not pending.

1: The exception is pending.

Note: The user can write to these bits to change the pending status of the exceptions.

- **USGFAULTPENDEDED: Usage Fault Exception Pending**

Read:

0: The exception is not pending.

1: The exception is pending.

Note: The user can write to these bits to change the pending status of the exceptions.

- **SYSTICKACT: SysTick Exception Active**

Read:

0: The exception is not active.

1: The exception is active.

Note: The user can write to these bits to change the active status of the exceptions.

- Caution: A software that changes the value of an active bit in this register without a correct adjustment to the stacked content can cause the processor to generate a fault exception. Ensure that the software writing to this register retains and subsequently restores the current active status.

- Caution: After enabling the system handlers, to change the value of a bit in this register, the user must use a read-modify-write procedure to ensure that only the required bit is changed.

- **PENDSVACT: PendSV Exception Active**

0: The exception is not active.

1: The exception is active.

- **MONITORACT: Debug Monitor Active**

0: Debug monitor is not active.

1: Debug monitor is active.

- **SVCALLACT: SVC Call Active**

0: SVC call is not active.

1: SVC call is active.

- **USGFAULTACT: Usage Fault Exception Active**

0: Usage fault exception is not active.

1: Usage fault exception is active.

- **BUSFAULTACT: Bus Fault Exception Active**

0: Bus fault exception is not active.

1: Bus fault exception is active.

- **MEMFAULTACT: Memory Management Fault Exception Active**

0: Memory management fault exception is not active.

1: Memory management fault exception is active.

If the user disables a system handler and the corresponding fault occurs, the processor treats the fault as a hard fault.

The user can write to this register to change the pending or active status of system exceptions. An OS kernel can write to the active bits to perform a context switch that changes the current exception type.

11.9.1.13 Configurable Fault Status Register

Name: SCB_CFSR

Access: Read-write

Reset: 0x00000000

31	30	29	28	27	26	25	24
						DIVBYZERO	UNALIGNED
23	22	21	20	19	18	17	16
				NOCP	INVPC	INVSTATE	UNDEFINSTR
15	14	13	12	11	10	9	8
BFRVALID			STKERR	UNSTKERR	IMPRECISERR	PRECISERR	IBUSERR
7	6	5	4	3	2	1	0
MMARVALID		MLSPERR	MSTKERR	MUNSTKERR		DACCVIOL	IACCVIOL

- **IACCVIOL: Instruction Access Violation flag**

This is part of [“MMFSR: Memory Management Fault Status Subregister”](#) .

0: No instruction access violation fault.

1: The processor attempted an instruction fetch from a location that does not permit execution.

This fault occurs on any access to an XN region, even when the MPU is disabled or not present.

When this bit is 1, the PC value stacked for the exception return points to the faulting instruction. The processor has not written a fault address to the SCB_MMFAR register.

- **DACCVIOL: Data Access Violation flag**

This is part of [“MMFSR: Memory Management Fault Status Subregister”](#) .

0: No data access violation fault.

1: The processor attempted a load or store at a location that does not permit the operation.

When this bit is 1, the PC value stacked for the exception return points to the faulting instruction. The processor has loaded the SCB_MMFAR register with the address of the attempted access.

- **MUNSTKERR: Memory Manager Fault on Unstacking for a Return From Exception**

This is part of [“MMFSR: Memory Management Fault Status Subregister”](#) .

0: No unstacking fault.

1: Unstack for an exception return has caused one or more access violations.

This fault is chained to the handler. This means that when this bit is 1, the original return stack is still present. The processor has not adjusted the SP from the failing return, and has not performed a new save. The processor has not written a fault address to the SCB_MMFAR register.

- **MSTKERR: Memory Manager Fault on Stacking for Exception Entry**

This is part of [“MMFSR: Memory Management Fault Status Subregister”](#) .

0: No stacking fault.

1: Stacking for an exception entry has caused one or more access violations.

When this bit is 1, the SP is still adjusted but the values in the context area on the stack might be incorrect. The processor has not written a fault address to SCB_MMFAR register.

- **MLSPERR: MemManage during Lazy State Preservation**

This is part of “[MMFSR: Memory Management Fault Status Subregister](#)” .

0: No MemManage fault occurred during the floating-point lazy state preservation.

1: A MemManage fault occurred during the floating-point lazy state preservation.

- **MMARVALID: Memory Management Fault Address Register (SCB_MMFAR) Valid Flag**

This is part of “[MMFSR: Memory Management Fault Status Subregister](#)” .

0: The value in SCB_MMFAR is not a valid fault address.

1: SCB_MMFAR register holds a valid fault address.

If a memory management fault occurs and is escalated to a hard fault because of priority, the hard fault handler must set this bit to 0. This prevents problems on return to a stacked active memory management fault handler whose SCB_MMFAR value has been overwritten.

- **IBUSERR: Instruction Bus Error**

This is part of “[BFSR: Bus Fault Status Subregister](#)” .

0: No instruction bus error.

1: Instruction bus error.

The processor detects the instruction bus error on prefetching an instruction, but it sets the IBUSERR flag to 1 only if it attempts to issue the faulting instruction.

When the processor sets this bit to 1, it does not write a fault address to the BFAR register.

- **PRECISERR: Precise Data Bus Error**

This is part of “[BFSR: Bus Fault Status Subregister](#)” .

0: No precise data bus error.

1: A data bus error has occurred, and the PC value stacked for the exception return points to the instruction that caused the fault.

When the processor sets this bit to 1, it writes the faulting address to the SCB_BFAR register.

- **IMPRECISERR: Imprecise Data Bus Error**

This is part of “[BFSR: Bus Fault Status Subregister](#)” .

0: No imprecise data bus error.

1: A data bus error has occurred, but the return address in the stack frame is not related to the instruction that caused the error.

When the processor sets this bit to 1, it does not write a fault address to the SCB_BFAR register.

This is an asynchronous fault. Therefore, if it is detected when the priority of the current process is higher than the bus fault priority, the bus fault becomes pending and becomes active only when the processor returns from all higher priority processes. If a precise fault occurs before the processor enters the handler for the imprecise bus fault, the handler detects that both this bit and one of the precise fault status bits are set to 1.

- **UNSTKERR: Bus Fault on Unstacking for a Return From Exception**

This is part of “[BFSR: Bus Fault Status Subregister](#)” .

0: No unstacking fault.

1: Unstack for an exception return has caused one or more bus faults.

This fault is chained to the handler. This means that when the processor sets this bit to 1, the original return stack is still present. The processor does not adjust the SP from the failing return, does not performed a new save, and does not write a fault address to the BFAR.

- **STKERR: Bus Fault on Stacking for Exception Entry**

This is part of “[BFSR: Bus Fault Status Subregister](#)” .

0: No stacking fault.

1: Stacking for an exception entry has caused one or more bus faults.

When the processor sets this bit to 1, the SP is still adjusted but the values in the context area on the stack might be incorrect. The processor does not write a fault address to the SCB_BFAR register.

- **BFARVALID: Bus Fault Address Register (BFAR) Valid flag**

This is part of “[BFSR: Bus Fault Status Subregister](#)” .

0: The value in SCB_BFAR is not a valid fault address.

1: SCB_BFAR holds a valid fault address.

The processor sets this bit to 1 after a bus fault where the address is known. Other faults can set this bit to 0, such as a memory management fault occurring later.

If a bus fault occurs and is escalated to a hard fault because of priority, the hard fault handler must set this bit to 0. This prevents problems if returning to a stacked active bus fault handler whose SCB_BFAR value has been overwritten.

- **UNDEFINSTR: Undefined Instruction Usage Fault**

This is part of “[UFSR: Usage Fault Status Subregister](#)” .

0: no undefined instruction usage fault.

1: the processor has attempted to execute an undefined instruction.

When this bit is set to 1, the PC value stacked for the exception return points to the undefined instruction.

An undefined instruction is an instruction that the processor cannot decode.

- **INVSTATE: Invalid State Usage Fault**

This is part of “[UFSR: Usage Fault Status Subregister](#)” .

0: No invalid state usage fault.

1: The processor has attempted to execute an instruction that makes illegal use of the EPSR.

When this bit is set to 1, the PC value stacked for the exception return points to the instruction that attempted the illegal use of the EPSR.

This bit is not set to 1 if an undefined instruction uses the EPSR.

- **INVPC: Invalid PC Load Usage Fault**

This is part of “[UFSR: Usage Fault Status Subregister](#)” . It is caused by an invalid PC load by EXC_RETURN:

0: No invalid PC load usage fault.

1: The processor has attempted an illegal load of EXC_RETURN to the PC, as a result of an invalid context, or an invalid EXC_RETURN value.

When this bit is set to 1, the PC value stacked for the exception return points to the instruction that tried to perform the illegal load of the PC.

- **NOCP: No Coprocessor Usage Fault**

This is part of “[UFSR: Usage Fault Status Subregister](#)” . The processor does not support coprocessor instructions:

0: No usage fault caused by attempting to access a coprocessor.

1: The processor has attempted to access a coprocessor.

- **UNALIGNED: Unaligned Access Usage Fault**

This is part of “[UFSR: Usage Fault Status Subregister](#)” .

0: No unaligned access fault, or unaligned access trapping not enabled.

1: The processor has made an unaligned memory access.

Enable trapping of unaligned accesses by setting the UNALIGN_TRP bit in the SCB_CCR register to 1. See “[Configuration and Control Register](#)” . Unaligned LDM, STM, LDRD, and STRD instructions always fault irrespective of the setting of UNALIGN_TRP.

- **DIVBYZERO: Divide by Zero Usage Fault**

This is part of “[UFSR: Usage Fault Status Subregister](#)” .

0: No divide by zero fault, or divide by zero trapping not enabled.

1: The processor has executed an SDIV or UDIV instruction with a divisor of 0.

When the processor sets this bit to 1, the PC value stacked for the exception return points to the instruction that performed the divide by zero. Enable trapping of divide by zero by setting the DIV_0_TRP bit in the SCB_CCR register to 1. See “[Configuration and Control Register](#)” .

11.9.1.14 Configurable Fault Status Register (Byte Access)

Name: SCB_CFSR (BYTE)

Access: Read-write

Reset: 0x00000000

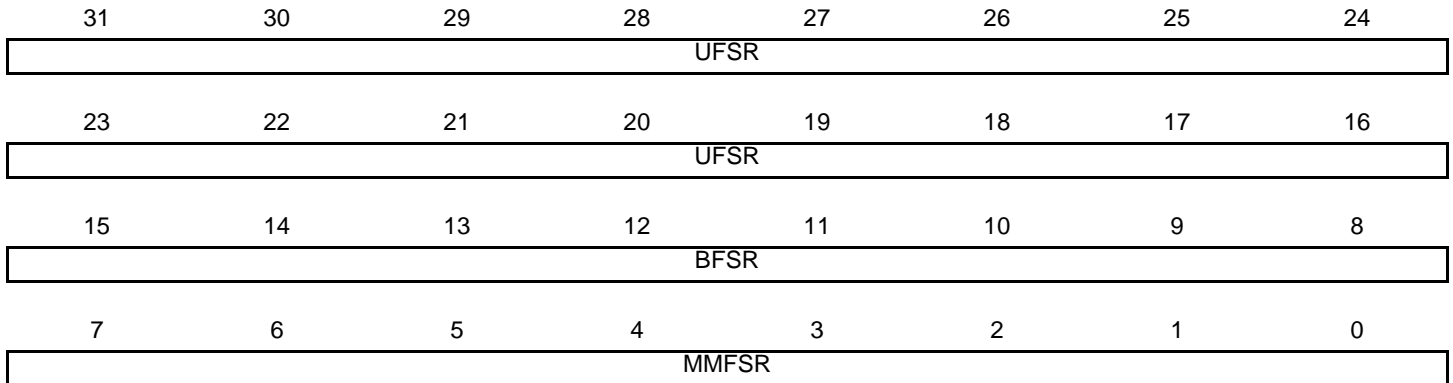

- **MMFSR: Memory Management Fault Status Subregister**

The flags in the MMFSR subregister indicate the cause of memory access faults. See bitfield [7..0] description in [Section 11.9.1.13](#).

- **BFSR: Bus Fault Status Subregister**

The flags in the BFSR subregister indicate the cause of a bus access fault. See bitfield [14..8] description in [Section 11.9.1.13](#).

- **UFSR: Usage Fault Status Subregister**

The flags in the UFSR subregister indicate the cause of a usage fault. See bitfield [31..15] description in [Section 11.9.1.13](#).

Note: The UFSR bits are sticky. This means that as one or more fault occurs, the associated bits are set to 1. A bit that is set to 1 is cleared to 0 only by writing 1 to that bit, or by a reset.

The SCB_CFSR register indicates the cause of a memory management fault, bus fault, or usage fault. It is byte accessible. The user can access the SCB_CFSR register or its subregisters as follows:

- access complete SCB_CFSR with a word access to 0xE00ED28
- access MMFSR with a byte access to 0xE00ED28
- access MMFSR and BFSR with a halfword access to 0xE00ED28
- access BFSR with a byte access to 0xE00ED29
- access UFSR with a halfword access to 0xE00ED2A.

11.9.1.15 Hard Fault Status Register

Name: SCB_HFSR

Access: Read-write

Reset: 0x00000000

31	30	29	28	27	26	25	24
DEBUGEVT	FORCED				–		
23	22	21	20	19	18	17	16
				–			
15	14	13	12	11	10	9	8
				–			
7	6	5	4	3	2	1	0
			–			VECTTBL	–

The HFSR register gives information about events that activate the hard fault handler. This register is read, write to clear. This means that bits in the register read normally, but writing 1 to any bit clears that bit to 0.

- **DEBUGEVT: Reserved for Debug Use**

When writing to the register, write 0 to this bit, otherwise the behavior is unpredictable.

- **FORCED: Forced Hard Fault**

It indicates a forced hard fault, generated by escalation of a fault with configurable priority that cannot be handles, either because of priority or because it is disabled:

0: No forced hard fault.

1: Forced hard fault.

When this bit is set to 1, the hard fault handler must read the other fault status registers to find the cause of the fault.

- **VECTTBL: Bus Fault on a Vector Table**

It indicates a bus fault on a vector table read during an exception processing:

0: No bus fault on vector table read.

1: Bus fault on vector table read.

This error is always handled by the hard fault handler.

When this bit is set to 1, the PC value stacked for the exception return points to the instruction that was preempted by the exception.

Note: The HFSR bits are sticky. This means that, as one or more fault occurs, the associated bits are set to 1. A bit that is set to 1 is cleared to 0 only by writing 1 to that bit, or by a reset.



11.9.1.16 MemManage Fault Address Register

Name: SCB_MMFAR

Access: Read-write

Reset: 0x00000000

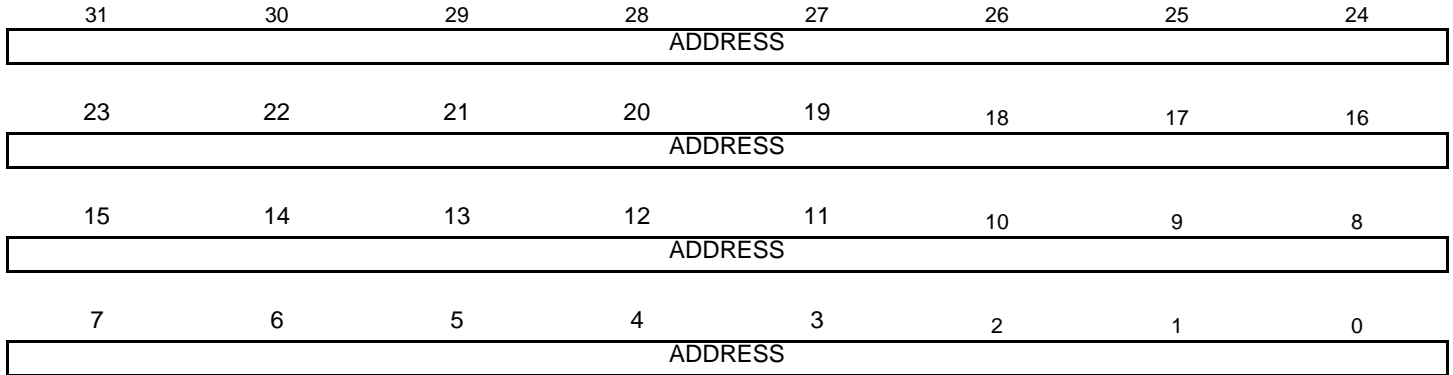

The MMFAR register contains the address of the location that generated a memory management fault.

- **ADDRESS**

When the MMARVALID bit of the MMFSR subregister is set to 1, this field holds the address of the location that generated the memory management fault.

- Notes:
1. When an unaligned access faults, the address is the actual address that faulted. Because a single read or write instruction can be split into multiple aligned accesses, the fault address can be any address in the range of the requested access size.
 2. Flags in the MMFSR subregister indicate the cause of the fault, and whether the value in the SCB_MMFAR register is valid. See [“MMFSR: Memory Management Fault Status Subregister”](#).

11.9.1.17 Bus Fault Address Register

Name: SCB_BFAR

Access: Read-write

Reset: 0x00000000

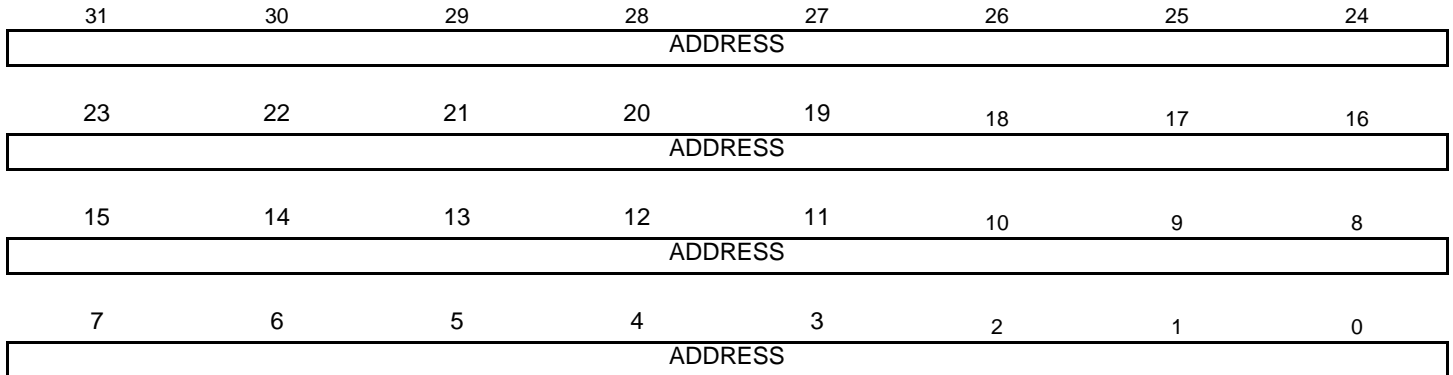

The BFAR register contains the address of the location that generated a bus fault.

- **ADDRESS**

When the BFARVALID bit of the BFSR subregister is set to 1, this field holds the address of the location that generated the bus fault.

- Notes:
1. When an unaligned access faults, the address in the SCB_BFAR register is the one requested by the instruction, even if it is not the address of the fault.
 2. Flags in the BFSR indicate the cause of the fault, and whether the value in the SCB_BFAR register is valid. See "[BFSR: Bus Fault Status Subregister](#)".

11.10 System Timer (SysTick)

The processor has a 24-bit system timer, SysTick, that counts down from the reload value to zero, reloads (wraps to) the value in the SYST_RVR register on the next clock edge, then counts down on subsequent clocks.

When the processor is halted for debugging, the counter does not decrement.

The SysTick counter runs on the processor clock. If this clock signal is stopped for low power mode, the SysTick counter stops.

Ensure that the software uses aligned word accesses to access the SysTick registers.

The SysTick counter reload and current value are undefined at reset; the correct initialization sequence for the SysTick counter is:

1. Program the reload value.
2. Clear the current value.
3. Program the Control and Status register.

11.10.1 System Timer (SysTick) User Interface

Table 11-33. System Timer (SysTick) Register Mapping

Offset	Register	Name	Access	Reset
0xE000E010	SysTick Control and Status Register	SYST_CSR	Read-write	0x00000004
0xE000E014	SysTick Reload Value Register	SYST_RVR	Read-write	Unknown
0xE000E018	SysTick Current Value Register	SYST_CVR	Read-write	Unknown
0xE000E01C	SysTick Calibration Value Register	SYST_CALIB	Read-only	0xC0000000

11.10.1.1 SysTick Control and Status

Name: SYST_CSR

Access: Read-write

Reset: 0x00000000

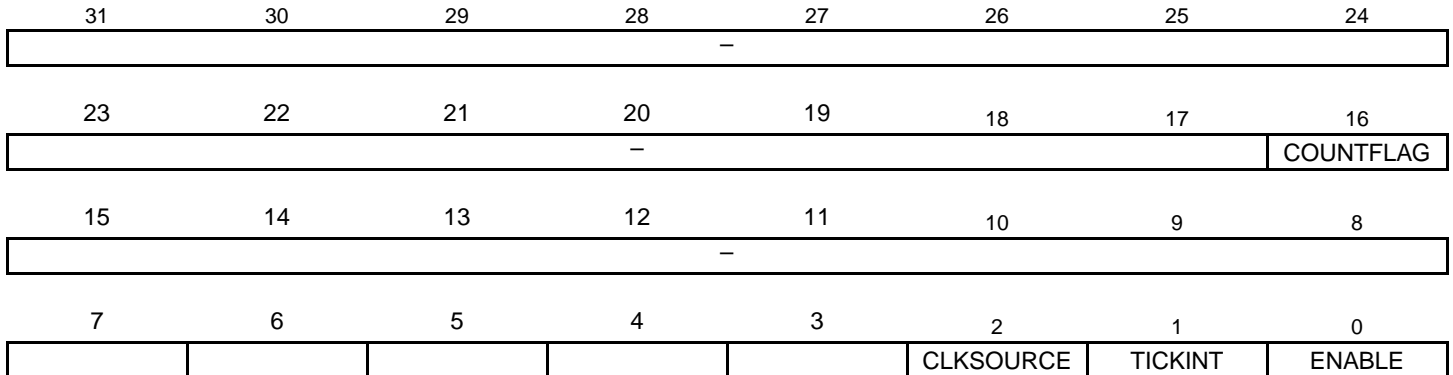

The SysTick SYST_CSR register enables the SysTick features.

- **COUNTFLAG: Count Flag**

Returns 1 if the timer counted to 0 since the last time this was read.

- **CLKSOURCE: Clock Source**

Indicates the clock source:

0: External Clock.

1: Processor Clock.

- **TICKINT**

Enables a SysTick exception request:

0: Counting down to zero does not assert the SysTick exception request.

1: Counting down to zero asserts the SysTick exception request.

The software can use COUNTFLAG to determine if SysTick has ever counted to zero.

- **ENABLE**

Enables the counter:

0: Counter disabled.

1: Counter enabled.

When ENABLE is set to 1, the counter loads the RELOAD value from the SYST_RVR register and then counts down. On reaching 0, it sets the COUNTFLAG to 1 and optionally asserts the SysTick depending on the value of TICKINT. It then loads the RELOAD value again, and begins counting.



11.10.1.2 SysTick Reload Value Registers

Name: SYST_RVR
Access: Read-write
Reset: 0x00000000

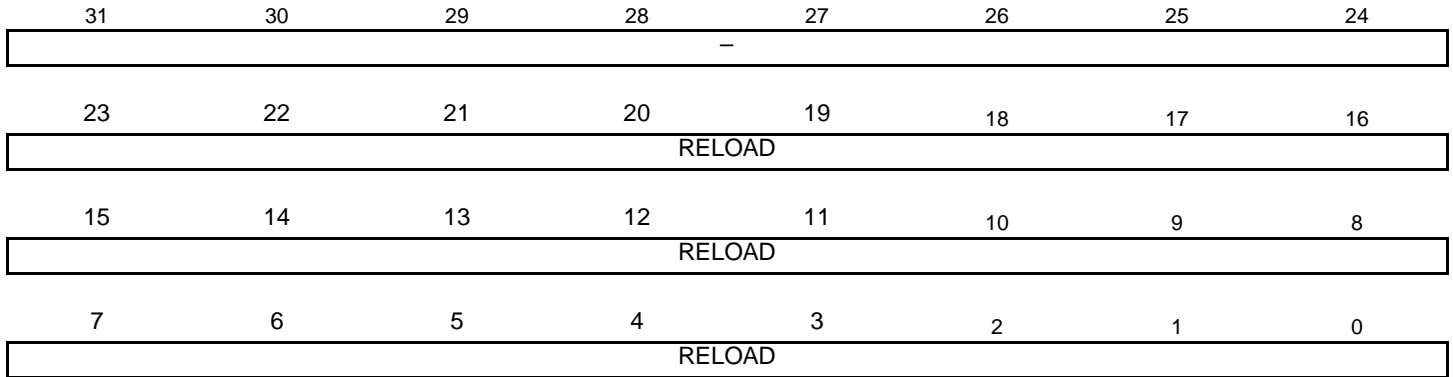

The SYST_RVR register specifies the start value to load into the SYST_CVR register.

- **RELOAD**

Value to load into the SYST_CVR register when the counter is enabled and when it reaches 0.

The RELOAD value can be any value in the range 0x00000001-0x00FFFFFF. A start value of 0 is possible, but has no effect because the SysTick exception request and COUNTFLAG are activated when counting from 1 to 0.

The RELOAD value is calculated according to its use: For example, to generate a multi-shot timer with a period of N processor clock cycles, use a RELOAD value of N-1. If the SysTick interrupt is required every 100 clock pulses, set RELOAD to 99.

11.10.1.3 SysTick Current Value Register

Name: SYST_CVR

Access: Read-write

Reset: 0x00000000

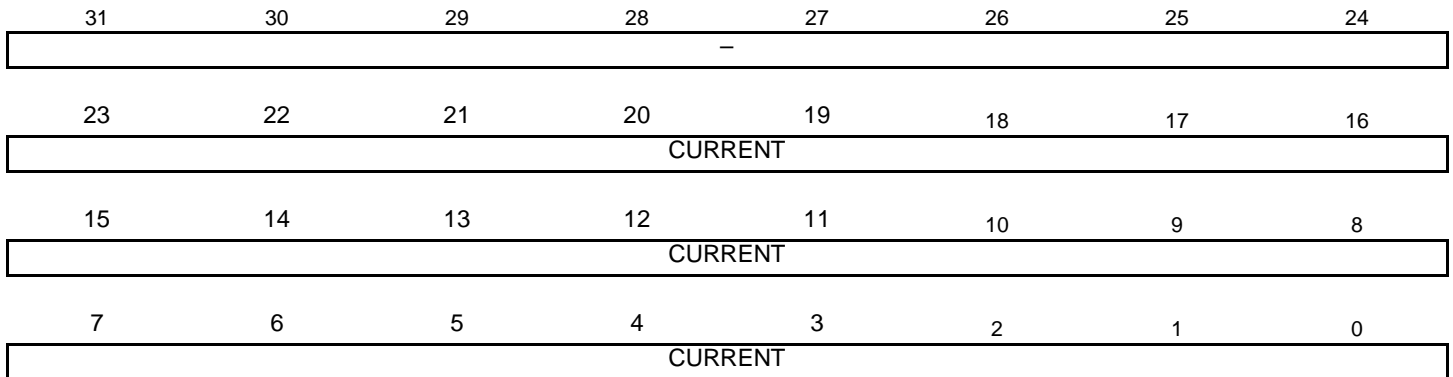

The SysTick SYST_CVR register contains the current value of the SysTick counter.

- **CURRENT**

Reads return the current value of the SysTick counter.

A write of any value clears the field to 0, and also clears the SYST_CSR.COUNTFLAG bit to 0.

11.10.1.4 SysTick Calibration Value Register

Name: SYST_CALIB

Access: Read-write

Reset: 0x00000000

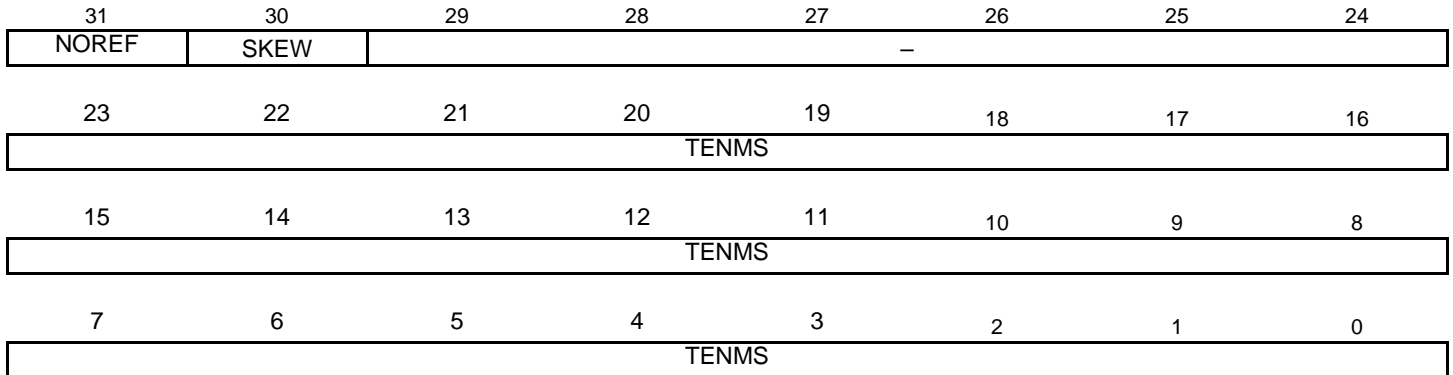

The SysTick SYST_CSR register indicates the SysTick calibration properties.

- **NOREF: No Reference Clock**

It indicates whether the device provides a reference clock to the processor:

0: Reference clock provided.

1: No reference clock provided.

If your device does not provide a reference clock, the SYST_CSR.CLKSOURCE bit reads-as-one and ignores writes.

- **SKEW**

It indicates whether the TENMS value is exact:

0: TENMS value is exact.

1: TENMS value is inexact, or not given.

An inexact TENMS value can affect the suitability of SysTick as a software real time clock.

- **TENMS: Ten Milliseconds**

The reload value for 10 ms (100 Hz) timing is subject to system clock skew errors. If the value reads as zero, the calibration value is not known.

Read as 0x000030D4. The SysTick calibration value is fixed at 0x000030D4 (12500), which allows the generation of a time base of 1 ms with SysTick clock at 12.5 MHz (100/8 = 12.5 MHz).

11.11 Memory Protection Unit (MPU)

The MPU divides the memory map into a number of regions, and defines the location, size, access permissions, and memory attributes of each region. It supports:

- independent attribute settings for each region
- overlapping regions
- export of memory attributes to the system.

The memory attributes affect the behavior of memory accesses to the region. The Cortex-M4 MPU defines:

- eight separate memory regions, 0-7
- a background region.

When memory regions overlap, a memory access is affected by the attributes of the region with the highest number. For example, the attributes for region 7 take precedence over the attributes of any region that overlaps region 7.

The background region has the same memory access attributes as the default memory map, but is accessible from privileged software only.

The Cortex-M4 MPU memory map is unified. This means that instruction accesses and data accesses have the same region settings.

If a program accesses a memory location that is prohibited by the MPU, the processor generates a memory management fault. This causes a fault exception, and might cause the termination of the process in an OS environment.

In an OS environment, the kernel can update the MPU region setting dynamically based on the process to be executed. Typically, an embedded OS uses the MPU for memory protection.

The configuration of MPU regions is based on memory types (see [“Memory Regions, Types and Attributes”](#)).

[Table 11-34](#) shows the possible MPU region attributes. These include Share ability and cache behavior attributes that are not relevant to most microcontroller implementations. See [“MPU Configuration for a Microcontroller”](#) for guidelines for programming such an implementation.

Table 11-34. Memory Attributes Summary

Memory Type	Shareability	Other Attributes	Description
Strongly- ordered	-	-	All accesses to Strongly-ordered memory occur in program order. All Strongly-ordered regions are assumed to be shared.
Device	Shared	-	Memory-mapped peripherals that several processors share.
	Non-shared	-	Memory-mapped peripherals that only a single processor uses.
Normal	Shared		Normal memory that is shared between several processors.
	Non-shared		Normal memory that only a single processor uses.

11.11.1 MPU Access Permission Attributes

This section describes the MPU access permission attributes. The access permission bits (TEX, C, B, S, AP, and XN) of the MPU_RASR control the access to the corresponding memory region. If an access is made to an area of memory without the required permissions, then the MPU generates a permission fault.

The table below shows the encodings for the TEX, C, B, and S access permission bits.

Table 11-35. TEX, C, B, and S Encoding

TEX	C	B	S	Memory Type	Shareability	Other Attributes
b000	0	0	x ⁽¹⁾	Strongly-ordered	Shareable	-
		1	x ⁽¹⁾	Device	Shareable	-
	1	0	0	Normal	Not shareable	Outer and inner write-through. No write allocate.
			1		Shareable	
		1	0	Normal	Not shareable	Outer and inner write-back. No write allocate.
			1		Shareable	
b001	0	0	0	Normal	Not shareable	
			1		Shareable	
		1	x ⁽¹⁾	Reserved encoding		
	1	0	x ⁽¹⁾	Implementation defined attributes.		-
		1	0	Normal	Not shareable	Outer and inner write-back. Write and read allocate.
			1		Shareable	
b010	0	0	x ⁽¹⁾	Device	Not shareable	Nonshared Device.
		1	x ⁽¹⁾	Reserved encoding		-
	1	x ⁽¹⁾	x ⁽¹⁾	Reserved encoding		-
b1B B	A	A	0	Normal	Not shareable	
			1		Shareable	

Note: 1. The MPU ignores the value of this bit.

Table 11-36 shows the cache policy for memory attribute encodings with a TEX value is in the range 4-7.

Table 11-36. Cache Policy for Memory Attribute Encoding

Encoding, AA or BB	Corresponding Cache Policy
00	Non-cacheable

Table 11-36. Cache Policy for Memory Attribute Encoding (Continued)

Encoding, AA or BB	Corresponding Cache Policy
01	Write back, write and read allocate
10	Write through, no write allocate
11	Write back, no write allocate

Table 11-37 shows the AP encodings that define the access permissions for privileged and unprivileged software.

Table 11-37. AP Encoding

AP[2:0]	Privileged Permissions	Unprivileged Permissions	Description
000	No access	No access	All accesses generate a permission fault
001	RW	No access	Access from privileged software only
010	RW	RO	Writes by unprivileged software generate a permission fault
011	RW	RW	Full access
100	Unpredictable	Unpredictable	Reserved
101	RO	No access	Reads by privileged software only
110	RO	RO	Read only, by privileged or unprivileged software
111	RO	RO	Read only, by privileged or unprivileged software

11.11.1.1 MPU Mismatch

When an access violates the MPU permissions, the processor generates a memory management fault, see “[Exceptions and Interrupts](#)”. The MMFSR indicates the cause of the fault. See “[MMFSR: Memory Management Fault Status Subregister](#)” for more information.

11.11.1.2 Updating an MPU Region

To update the attributes for an MPU region, update the MPU_RNR, MPU_RBAR and MPU_RASR registers. Each register can be programmed separately, or a multiple-word write can be used to program all of these registers. MPU_RBAR and MPU_RASR aliases can be used to program up to four regions simultaneously using an STM instruction.

11.11.1.3 Updating an MPU region using separate words

Simple code to configure one region:

```

; R1 = region number
; R2 = size/enable
; R3 = attributes
; R4 = address
LDR R0,=MPU_RNR           ; 0xE000ED98, MPU region number register
STR R1, [R0, #0x0]       ; Region Number
STR R4, [R0, #0x4]       ; Region Base Address
STRH R2, [R0, #0x8]      ; Region Size and Enable
STRH R3, [R0, #0xA]      ; Region Attribute
    
```

Disable a region before writing new region settings to the MPU, if the region being changed was previously enabled . For example:

```

; R1 = region number
; R2 = size/enable
; R3 = attributes
; R4 = address
LDR R0,=MPU_RNR          ; 0xE000ED98, MPU region number register
STR R1, [R0, #0x0]      ; Region Number
BIC R2, R2, #1          ; Disable
STRH R2, [R0, #0x8]     ; Region Size and Enable
STR R4, [R0, #0x4]      ; Region Base Address
STRH R3, [R0, #0xA]     ; Region Attribute
ORR R2, #1              ; Enable
STRH R2, [R0, #0x8]     ; Region Size and Enable

```

The software must use memory barrier instructions:

- before the MPU setup, if there might be outstanding memory transfers, such as buffered writes, that might be affected by the change in MPU settings
- after the MPU setup, if it includes memory transfers that must use the new MPU settings.

However, memory barrier instructions are not required if the MPU setup process starts by entering an exception handler, or is followed by an exception return, because the exception entry and exception return mechanisms cause memory barrier behavior.

The software does not need any memory barrier instructions during an MPU setup, because it accesses the MPU through the PPB, which is a Strongly-Ordered memory region.

For example, if the user wants all of the memory access behavior to take effect immediately after the programming sequence, a DSB instruction and an ISB instruction must be used. A DSB is required after changing MPU settings, such as at the end of a context switch. An ISB is required if the code that programs the MPU region or regions is entered using a branch or call. If the programming sequence is entered using a return from exception, or by taking an exception, then an ISB is not required .

11.11.1.4 Updating an MPU Region Using Multi-word Writes

The user can program directly using multi-word writes, depending on how the information is divided. Consider the following reprogramming:

```

; R1 = region number
; R2 = address
; R3 = size, attributes in one
LDR R0, =MPU_RNR        ; 0xE000ED98, MPU region number register
STR R1, [R0, #0x0]      ; Region Number
STR R2, [R0, #0x4]      ; Region Base Address
STR R3, [R0, #0x8]      ; Region Attribute, Size and Enable

```

Use an STM instruction to optimize this:

```

; R1 = region number
; R2 = address
; R3 = size, attributes in one
LDR R0, =MPU_RNR      ; 0xE000ED98, MPU region number register
STM R0, {R1-R3}      ; Region Number, address, attribute, size and enable

```

This can be done in two words for pre-packed information. This means that the MPU_RBAR contains the required region number and had the VALID bit set to 1. See “[MPU Region Base Address Register](#)”. Use this when the data is statically packed, for example in a boot loader:

```

; R1 = address and region number in one
; R2 = size and attributes in one
LDR R0, =MPU_RBAR    ; 0xE000ED9C, MPU Region Base register
STR R1, [R0, #0x0]   ; Region base address and
                    ; region number combined with VALID (bit 4) set to 1
STR R2, [R0, #0x4]   ; Region Attribute, Size and Enable

```

Use an STM instruction to optimize this:

```

; R1 = address and region number in one
; R2 = size and attributes in one
LDR R0, =MPU_RBAR    ; 0xE000ED9C, MPU Region Base register
STM R0, {R1-R2}      ; Region base address, region number and VALID bit,
                    ; and Region Attribute, Size and Enable

```

11.11.1.5 Subregions

Regions of 256 bytes or more are divided into eight equal-sized subregions. Set the corresponding bit in the SRD field of the MPU_RASR field to disable a subregion. See “[MPU Region Attribute and Size Register](#)”. The least significant bit of SRD controls the first subregion, and the most significant bit controls the last subregion. Disabling a subregion means another region overlapping the disabled range matches instead. If no other enabled region overlaps the disabled subregion, the MPU issues a fault.

Regions of 32, 64, and 128 bytes do not support subregions. With regions of these sizes, the SRD field must be set to 0x00, otherwise the MPU behavior is unpredictable.

11.11.1.6 Example of SRD Use

Two regions with the same base address overlap. Region 1 is 128 KB, and region 2 is 512 KB. To ensure the attributes from region 1 apply to the first 128 KB region, set the SRD field for region 2 to b00000011 to disable the first two subregions, as in [Figure 11-12](#) below:

Figure 11-12. SRD Use

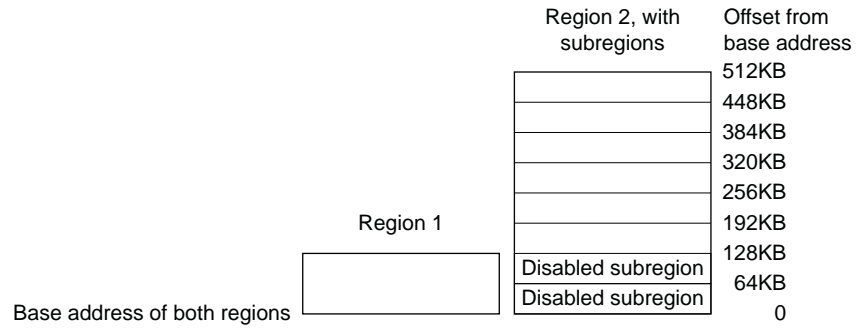

11.11.1.7 MPU Design Hints And Tips

To avoid unexpected behavior, disable the interrupts before updating the attributes of a region that the interrupt handlers might access.

Ensure the software uses aligned accesses of the correct size to access MPU registers:

- except for the MPU_RASR register, it must use aligned word accesses
- for the MPU_RASR register, it can use byte or aligned halfword or word accesses.

The processor does not support unaligned accesses to MPU registers.

When setting up the MPU, and if the MPU has previously been programmed, disable unused regions to prevent any previous region settings from affecting the new MPU setup.

MPU Configuration for a Microcontroller

Usually, a microcontroller system has only a single processor and no caches. In such a system, program the MPU as follows:

Table 11-38. Memory region attributes for a microcontroller

Memory Region	TEX	C	B	S	Memory Type and Attributes
Flash memory	b000	1	0	0	Normal memory, non-shareable, write-through
Internal SRAM	b000	1	0	1	Normal memory, shareable, write-through
External SRAM	b000	1	1	1	Normal memory, shareable, write-back, write-allocate
Peripherals	b000	0	1	1	Device memory, shareable

In most microcontroller implementations, the share ability and cache policy attributes do not affect the system behavior. However, using these settings for the MPU regions can make the application code more portable. The values given are for typical situations. In special systems, such as multiprocessor designs or designs with a separate DMA engine, the share ability attribute might be important. In these cases, refer to the recommendations of the memory device manufacturer.

11.11.2 Memory Protection Unit (MPU) User Interface

Table 11-39. Memory Protection Unit (MPU) Register Mapping

Offset	Register	Name	Access	Reset
0xE000ED90	MPU Type Register	MPU_TYPE	Read-only	0x00000800
0xE000ED94	MPU Control Register	MPU_CTRL	Read-write	0x00000000
0xE000ED98	MPU Region Number Register	MPU_RNR	Read-write	0x00000000
0xE000ED9C	MPU Region Base Address Register	MPU_RBAR	Read-write	0x00000000
0xE000EDA0	MPU Region Attribute and Size Register	MPU_RASR	Read-write	0x00000000
0xE000EDA4	Alias of RBAR, see MPU Region Base Address Register	MPU_RBAR_A1	Read-write	0x00000000
0xE000EDA8	Alias of RASR, see MPU Region Attribute and Size Register	MPU_RASR_A1	Read-write	0x00000000
0xE000EDAC	Alias of RBAR, see MPU Region Base Address Register	MPU_RBAR_A2	Read-write	0x00000000
0xE000EDB0	Alias of RASR, see MPU Region Attribute and Size Register	MPU_RASR_A2	Read-write	0x00000000
0xE000EDB4	Alias of RBAR, see MPU Region Base Address Register	MPU_RBAR_A3	Read-write	0x00000000
0xE000EDB8	Alias of RASR, see MPU Region Attribute and Size Register	MPU_RASR_A3	Read-write	0x00000000

11.11.2.1 MPU Type Register

Name: MPU_TYPE
Access: Read-write
Reset: 0x00000800

31	30	29	28	27	26	25	24
-							
23	22	21	20	19	18	17	16
IREGION							
15	14	13	12	11	10	9	8
DREGION							
7	6	5	4	3	2	1	0
-							SEPARATE

The MPU_TYPE register indicates whether the MPU is present, and if so, how many regions it supports.

- **IREGION: Instruction Region**

Indicates the number of supported MPU instruction regions.

Always contains 0x00. The MPU memory map is unified and is described by the DREGION field.

- **DREGION: Data Region**

Indicates the number of supported MPU data regions:

0x08 = Eight MPU regions.

- **SEPARATE: Separate Instruction**

Indicates support for unified or separate instruction and data memory maps:

0: unified.

11.11.2.2 MPU Control Register

Name: MPU_CTRL
Access: Read-write
Reset: 0x00000800

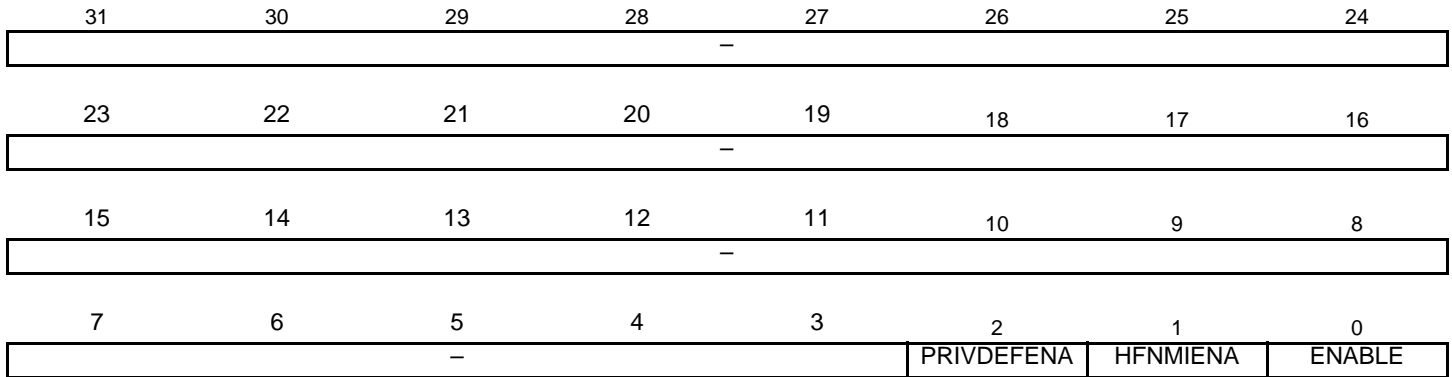

The MPU CTRL register enables the MPU, enables the default memory map background region, and enables the use of the MPU when in the hard fault, Non-maskable Interrupt (NMI), and FAULTMASK escalated handlers.

- **PRIVDEFENA: Privileged Default Memory Map Enabled**

Enables privileged software access to the default memory map:

0: If the MPU is enabled, disables the use of the default memory map. Any memory access to a location not covered by any enabled region causes a fault.

1: If the MPU is enabled, enables the use of the default memory map as a background region for privileged software accesses.

When enabled, the background region acts as a region number -1. Any region that is defined and enabled has priority over this default map.

If the MPU is disabled, the processor ignores this bit.

- **HFNMIENA: Hard Fault and NMI Enabled**

Enables the operation of MPU during hard fault, NMI, and FAULTMASK handlers.

When the MPU is enabled:

0: MPU is disabled during hard fault, NMI, and FAULTMASK handlers, regardless of the value of the ENABLE bit.

1: the MPU is enabled during hard fault, NMI, and FAULTMASK handlers.

When the MPU is disabled, if this bit is set to 1, the behavior is unpredictable.

- **ENABLE**

Enables the MPU:

0: MPU disabled.

1: MPU enabled.

When ENABLE and PRIVDEFENA are both set to 1:

- For privileged accesses, the *default memory map* is as described in [“Memory Model”](#). Any access by privileged software that does not address an enabled memory region behaves as defined by the default memory map.

- Any access by unprivileged software that does not address an enabled memory region causes a memory management fault.

XN and Strongly-ordered rules always apply to the System Control Space regardless of the value of the ENABLE bit.

When the ENABLE bit is set to 1, at least one region of the memory map must be enabled for the system to function unless the PRIVDEFENA bit is set to 1. If the PRIVDEFENA bit is set to 1 and no regions are enabled, then only privileged software can operate.

When the ENABLE bit is set to 0, the system uses the default memory map. This has the same memory attributes as if the MPU is not implemented. The default memory map applies to accesses from both privileged and unprivileged software.

When the MPU is enabled, accesses to the System Control Space and vector table are always permitted. Other areas are accessible based on regions and whether PRIVDEFENA is set to 1.

Unless HFNMIENA is set to 1, the MPU is not enabled when the processor is executing the handler for an exception with priority -1 or -2. These priorities are only possible when handling a hard fault or NMI exception, or when FAULTMASK is enabled. Setting the HFNMIENA bit to 1 enables the MPU when operating with these two priorities.

11.11.2.3 MPU Region Number Register

Name: MPU_RNR
Access: Read-write
Reset: 0x00000800

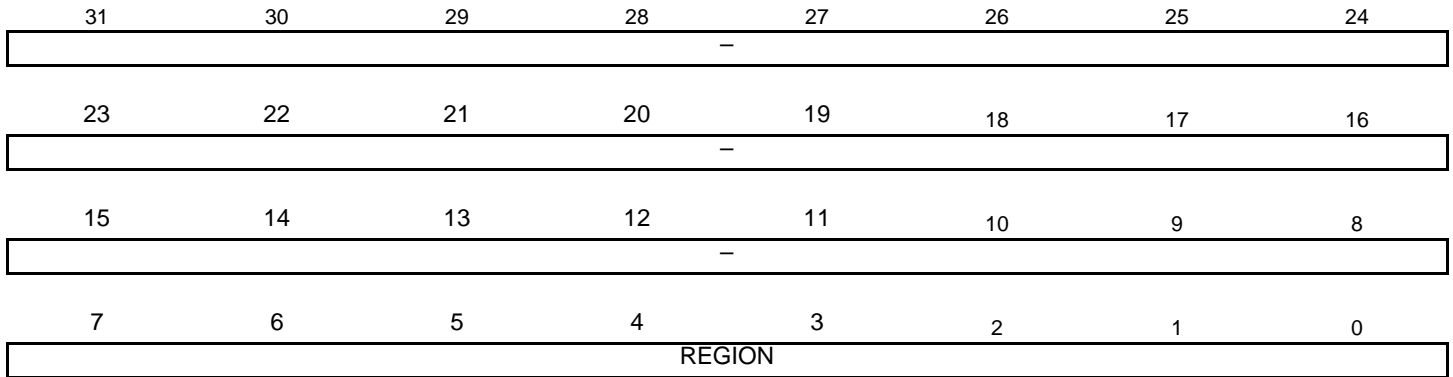

The MPU_RNR selects which memory region is referenced by the MPU_RBAR and MPU_RASR registers.

- **REGION**

Indicates the MPU region referenced by the MPU_RBAR and MPU_RASR registers.

The MPU supports 8 memory regions, so the permitted values of this field are 0-7.

Normally, the required region number is written to this register before accessing the MPU_RBAR or MPU_RASR. However, the region number can be changed by writing to the MPU_RBAR with the VALID bit set to 1; see [“MPU Region Base Address Register”](#). This write updates the value of the REGION field.



11.11.2.4 MPU Region Base Address Register

Name: MPU_RBAR

Access: Read-write

Reset: 0x00000000

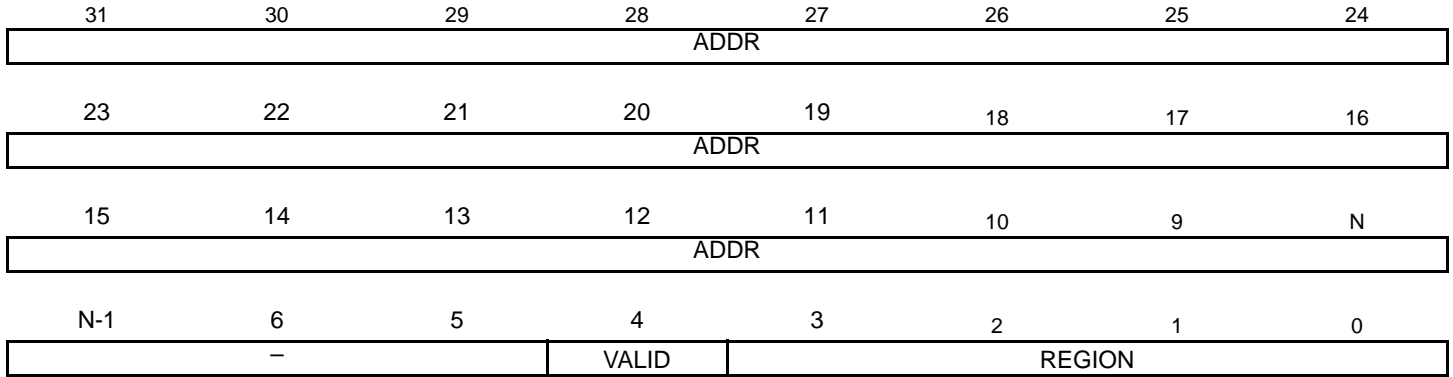

Note: If the region size is 32B, the ADDR field is bits [31:5] and there is no Reserved field.

The MPU_RBAR defines the base address of the MPU region selected by the MPU_RNR, and can update the value of the MPU_RNR.

Write MPU_RBAR with the VALID bit set to 1 to change the current region number and update the MPU_RNR.

• **ADDR: Region Base Address**

The value of N depends on the region size. The ADDR field is bits[31:N] of the MPU_RBAR. The region size, as specified by the SIZE field in the MPU_RASR, defines the value of N:

$$N = \text{Log}_2(\text{Region size in bytes}),$$

If the region size is configured to 4 GB, in the MPU_RASR, there is no valid ADDR field. In this case, the region occupies the complete memory map, and the base address is 0x00000000.

The base address is aligned to the size of the region. For example, a 64 KB region must be aligned on a multiple of 64 KB, for example, at 0x00010000 or 0x00020000.

• **VALID: MPU Region Number Valid**

Write:

0: MPU_RNR not changed, and the processor updates the base address for the region specified in the MPU_RNR, and ignores the value of the REGION field.

1: the processor updates the value of the MPU_RNR to the value of the REGION field, and updates the base address for the region specified in the REGION field.

Always reads as zero.

• **REGION: MPU Region**

For the behavior on writes, see the description of the VALID field.

On reads, returns the current region number, as specified by the MPU_RNR.

11.11.2.5 MPU Region Attribute and Size Register

Name: MPU_RASR

Access: Read-write

Reset: 0x00000000

31	30	29	28	27	26	25	24
-			XN	-	AP		
23	22	21	20	19	18	17	16
-		TEX			S	C	B
15	14	13	12	11	10	9	8
SRD							
7	6	5	4	3	2	1	0
-		SIZE					ENABLE

The MPU_RASR defines the region size and memory attributes of the MPU region specified by the MPU_RNR, and enables that region and any subregions.

MPU_RASR is accessible using word or halfword accesses:

- the most significant halfword holds the region attributes.
- the least significant halfword holds the region size, and the region and subregion enable bits.

• XN: Instruction Access Disable

0: Instruction fetches enabled.

1: Instruction fetches disabled.

• AP: Access Permission

See [Table 11-37](#).

• TEX, C, B: Memory Access Attributes

See [Table 11-35](#).

• S: Shareable

See [Table 11-35](#).

• SRD: Subregion Disable

For each bit in this field:

0: corresponding sub-region is enabled.

1: corresponding sub-region is disabled.

See [“Subregions”](#) for more information.

Region sizes of 128 bytes and less do not support subregions. When writing the attributes for such a region, write the SRD field as 0x00.

- **SIZE: Size of the MPU Protection Region**

The minimum permitted value is 3 (b00010).

The SIZE field defines the size of the MPU memory region specified by the MPU_RNR. as follows:

$$(\text{Region size in bytes}) = 2^{(\text{SIZE}+1)}$$

The smallest permitted region size is 32B, corresponding to a SIZE value of 4. The table below gives an example of SIZE values, with the corresponding region size and value of N in the MPU_RBAR.

SIZE value	Region size	Value of N ⁽¹⁾	Note
b00100 (4)	32 B	5	Minimum permitted size
b01001 (9)	1 KB	10	-
b10011 (19)	1 MB	20	-
b11101 (29)	1 GB	30	-
b11111 (31)	4 GB	b01100	Maximum possible size

Note: 1. In the MPU_RBAR, see [“MPU Region Base Address Register”](#)

- **ENABLE: Region Enable**

Note: For information about access permission, see [“MPU Access Permission Attributes”](#).

11.12 Glossary

This glossary describes some of the terms used in technical documents from ARM.

Abort	A mechanism that indicates to a processor that the value associated with a memory access is invalid. An abort can be caused by the external or internal memory system as a result of attempting to access invalid instruction or data memory.
Aligned	A data item stored at an address that is divisible by the number of bytes that defines the data size is said to be aligned. Aligned words and halfwords have addresses that are divisible by four and two respectively. The terms word-aligned and halfword-aligned therefore stipulate addresses that are divisible by four and two respectively.
Banked register	A register that has multiple physical copies, where the state of the processor determines which copy is used. The Stack Pointer, SP (R13) is a banked register.
Base register	In instruction descriptions, a register specified by a load or store instruction that is used to hold the base value for the instruction's address calculation. Depending on the instruction and its addressing mode, an offset can be added to or subtracted from the base register value to form the address that is sent to memory. <i>See also</i> "Index register"
Big-endian (BE)	Byte ordering scheme in which bytes of decreasing significance in a data word are stored at increasing addresses in memory. <i>See also</i> "Byte-invariant" , "Endianness" , "Little-endian (LE)" .
Big-endian memory	Memory in which: a byte or halfword at a word-aligned address is the most significant byte or halfword within the word at that address, a byte at a halfword-aligned address is the most significant byte within the halfword at that address. <i>See also</i> "Little-endian memory" .
Breakpoint	A breakpoint is a mechanism provided by debuggers to identify an instruction at which program execution is to be halted. Breakpoints are inserted by the programmer to enable inspection of register contents, memory locations, variable values at fixed points in the program execution to test that the program is operating correctly. Breakpoints are removed after the program is successfully tested.
Byte-invariant	In a byte-invariant system, the address of each byte of memory remains unchanged when switching between little-endian and big-endian operation. When a data item larger than a byte is loaded from or stored to memory, the bytes making up that data item are arranged into the correct order depending on the endianness of the memory access. An ARM byte-invariant implementation also supports unaligned halfword and word memory accesses. It expects multi-word accesses to be word-aligned.

Condition field	A four-bit field in an instruction that specifies a condition under which the instruction can execute.
Conditional execution	If the condition code flags indicate that the corresponding condition is true when the instruction starts executing, it executes normally. Otherwise, the instruction does nothing.
Context	The environment that each process operates in for a multitasking operating system. In ARM processors, this is limited to mean the physical address range that it can access in memory and the associated memory access permissions.
Coprocessor	A processor that supplements the main processor. Cortex-M4 does not support any coprocessors.
Debugger	A debugging system that includes a program, used to detect, locate, and correct software faults, together with custom hardware that supports software debugging.
Direct Memory Access (DMA)	An operation that accesses main memory directly, without the processor performing any accesses to the data concerned.
Doubleword	A 64-bit data item. The contents are taken as being an unsigned integer unless otherwise stated.
Doubleword-aligned	A data item having a memory address that is divisible by eight.
Endianness	Byte ordering. The scheme that determines the order that successive bytes of a data word are stored in memory. An aspect of the system's memory mapping. <i>See also</i> "Little-endian (LE)" and "Big-endian (BE)"
Exception	An event that interrupts program execution. When an exception occurs, the processor suspends the normal program flow and starts execution at the address indicated by the corresponding exception vector. The indicated address contains the first instruction of the handler for the exception. An exception can be an interrupt request, a fault, or a software-generated system exception. Faults include attempting an invalid memory access, attempting to execute an instruction in an invalid processor state, and attempting to execute an undefined instruction.
Exception service routine	<i>See</i> "Interrupt handler" .
Exception vector	<i>See</i> "Interrupt vector" .
Flat address mapping	A system of organizing memory in which each physical address in the memory space is the same as the corresponding virtual address.

Halfword	A 16-bit data item.
Illegal instruction	An instruction that is architecturally Undefined.
Implementation-defined	The behavior is not architecturally defined, but is defined and documented by individual implementations.
Implementation-specific	The behavior is not architecturally defined, and does not have to be documented by individual implementations. Used when there are a number of implementation options available and the option chosen does not affect software compatibility.
Index register	In some load and store instruction descriptions, the value of this register is used as an offset to be added to or subtracted from the base register value to form the address that is sent to memory. Some addressing modes optionally enable the index register value to be shifted prior to the addition or subtraction. <i>See also</i> “ Base register ” .
Instruction cycle count	The number of cycles that an instruction occupies the Execute stage of the pipeline.
Interrupt handler	A program that control of the processor is passed to when an interrupt occurs.
Interrupt vector	One of a number of fixed addresses in low memory, or in high memory if high vectors are configured, that contains the first instruction of the corresponding interrupt handler.
Little-endian (LE)	Byte ordering scheme in which bytes of increasing significance in a data word are stored at increasing addresses in memory. <i>See also</i> “ Big-endian (BE) ” , “ Byte-invariant ” , “ Endianness ” .
Little-endian memory	Memory in which: a byte or halfword at a word-aligned address is the least significant byte or halfword within the word at that address, a byte at a halfword-aligned address is the least significant byte within the halfword at that address. <i>See also</i> “ Big-endian memory ” .
Load/store architecture	A processor architecture where data-processing operations only operate on register contents, not directly on memory contents.
Memory Protection Unit (MPU)	Hardware that controls access permissions to blocks of memory. An MPU does not perform any address translation.
Prefetching	In pipelined processors, the process of fetching instructions from memory to fill up the pipeline before the preceding instructions have finished executing. Prefetching an instruction does not mean that the instruction has to be executed.



Preserved	Preserved by writing the same value back that has been previously read from the same field on the same processor.
Read	Reads are defined as memory operations that have the semantics of a load. Reads include the Thumb instructions LDM, LDR, LDRSH, LDRH, LDRSB, LDRB, and POP.
Region	A partition of memory space.
Reserved	A field in a control register or instruction format is reserved if the field is to be defined by the implementation, or produces Unpredictable results if the contents of the field are not zero. These fields are reserved for use in future extensions of the architecture or are implementation-specific. All reserved bits not used by the implementation must be written as 0 and read as 0.
Thread-safe	In a multi-tasking environment, thread-safe functions use safeguard mechanisms when accessing shared resources, to ensure correct operation without the risk of shared access conflicts.
Thumb instruction	One or two halfwords that specify an operation for a processor to perform. Thumb instructions must be halfword-aligned.
Unaligned	A data item stored at an address that is not divisible by the number of bytes that defines the data size is said to be unaligned. For example, a word stored at an address that is not divisible by four.
Undefined	Indicates an instruction that generates an Undefined instruction exception.
Unpredictable	One cannot rely on the behavior. Unpredictable behavior must not represent security holes. Unpredictable behavior must not halt or hang the processor, or any parts of the system.
Warm reset	Also known as a core reset. Initializes the majority of the processor excluding the debug controller and debug logic. This type of reset is useful if debugging features of a processor.
Word	A 32-bit data item.
Write	Writes are defined as operations that have the semantics of a store. Writes include the Thumb instructions STM, STR, STRH, STRB, and PUSH.

12. Debug and Test Features

12.1 Description

The SAM4 Series Microcontrollers feature a number of complementary debug and test capabilities. The Serial Wire/JTAG Debug Port (SWJ-DP) combining a Serial Wire Debug Port (SW-DP) and JTAG Debug (JTAG-DP) port is used for standard debugging functions, such as downloading code and single-stepping through programs. It also embeds a serial wire trace.

12.2 Embedded Characteristics

- Debug access to all memory and registers in the system, including Cortex-M4 register bank when the core is running, halted, or held in reset.
- Serial Wire Debug Port (SW-DP) and Serial Wire JTAG Debug Port (SWJ-DP) debug access
- Flash Patch and Breakpoint (FPB) unit for implementing breakpoints and code patches
- Data Watchpoint and Trace (DWT) unit for implementing watchpoints, data tracing, and system profiling
- Instrumentation Trace Macrocell (ITM) for support of printf style debugging
- IEEE1149.1 JTAG Boundary-can on All Digital Pins

Figure 12-1. Debug and Test Block Diagram

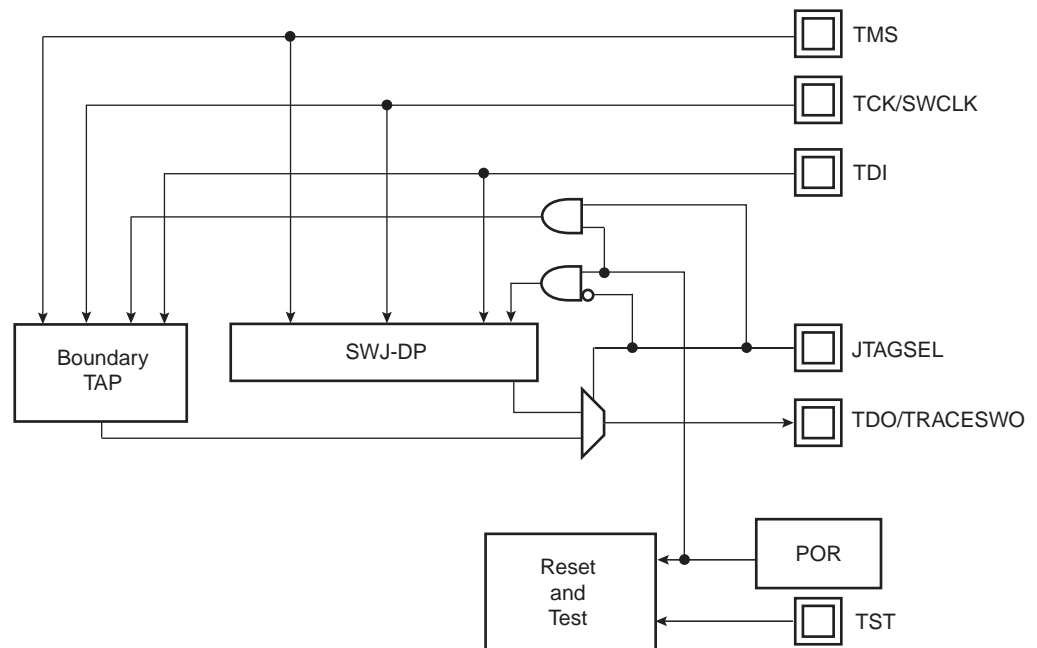

12.3 Application Examples

12.3.1 Debug Environment

Figure 12-2 shows a complete debug environment example. The SWJ-DP interface is used for standard debugging functions, such as downloading code and single-stepping through the program and viewing core and peripheral registers.

Figure 12-2. Application Debug Environment Example

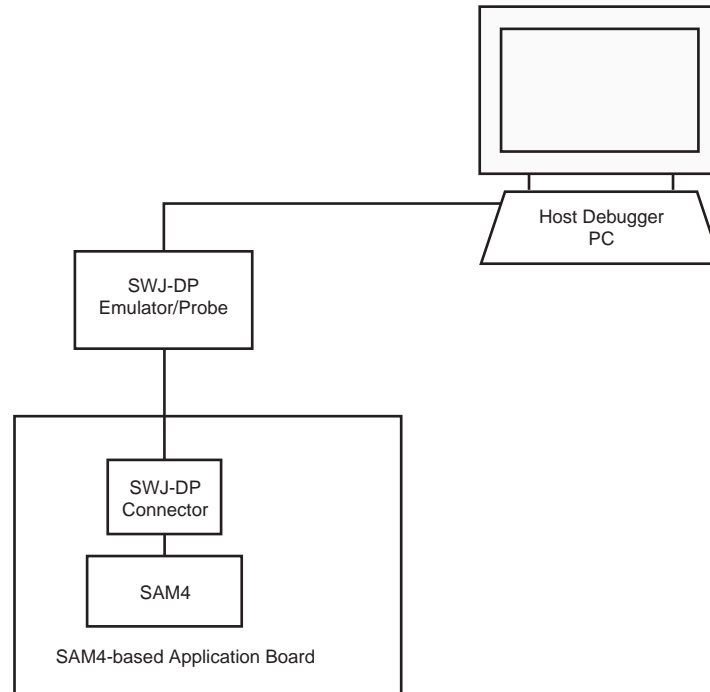

12.3.2 Test Environment

Figure 12-3 shows a test environment example (JTAG Boundary scan). Test vectors are sent and interpreted by the tester. In this example, the “board in test” is designed using a number of JTAG-compliant devices. These devices can be connected to form a single scan chain.

Figure 12-3. Application Test Environment Example

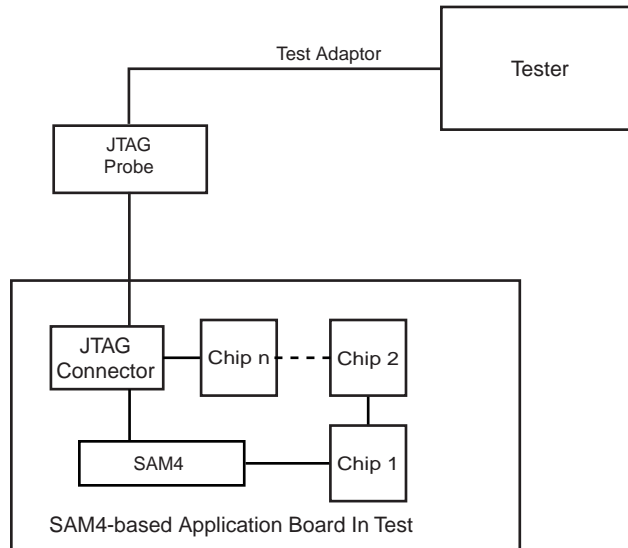

12.4 Debug and Test Pin Description

Table 12-1. Debug and Test Signal List

Signal Name	Function	Type	Active Level
Reset/Test			
NRST	Microcontroller Reset	Input/Output	Low
TST	Test Select	Input	
SWD/JTAG			
TCK/SWCLK	Test Clock/Serial Wire Clock	Input	
TDI	Test Data In	Input	
TDO/TRACESWO	Test Data Out/Trace Asynchronous Data Out	Output	
TMS/SWDIO	Test Mode Select/Serial Wire Input/Output	Input	
JTAGSEL	JTAG Selection	Input	High

12.5 Functional Description

12.5.1 Test Pin

One dedicated pin, TST, is used to define the device operating mode. When this pin is at low level during power-up, the device is in normal operating mode. When at high level, the device is in test mode or FFPI mode. The TST pin integrates a permanent pull-down resistor of about 15 k Ω , so that it can be left unconnected for normal operation. Note that when setting the TST pin to low or high level at power up, it must remain in the same state during the duration of the whole operation.

12.5.2 Debug Architecture

Figure 12-4 shows the Debug Architecture used in the SAM4. The Cortex-M4 embeds four functional units for debug:

- SWJ-DP (Serial Wire/JTAG Debug Port)
- FPB (Flash Patch Breakpoint)
- DWT (Data Watchpoint and Trace)
- ITM (Instrumentation Trace Macrocell)
- TPIU (Trace Port Interface Unit)

The debug architecture information that follows is mainly dedicated to developers of SWJ-DP Emulators/Probes and debugging tool vendors for Cortex-M4 based microcontrollers. For further details on SWJ-DP see the Cortex-M4 technical reference manual.

Figure 12-4. Debug Architecture

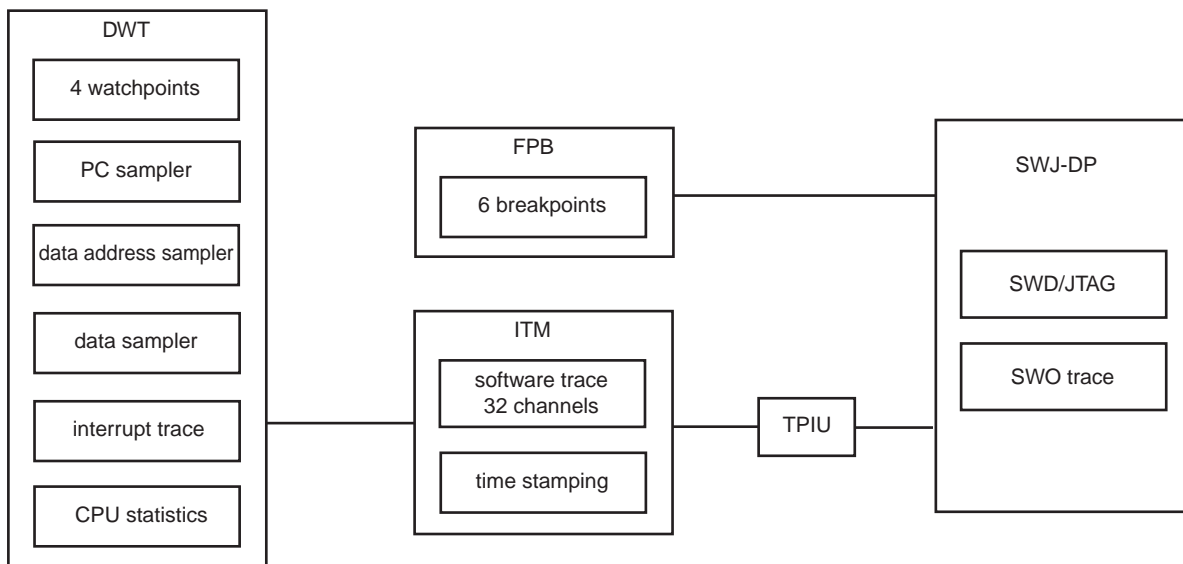

12.5.3 Serial Wire/JTAG Debug Port (SWJ-DP)

The Cortex-M4 embeds a SWJ-DP Debug port which is the standard CoreSight™ debug port. It combines Serial Wire Debug Port (SW-DP), from 2 to 3 pins and JTAG debug Port (JTAG-DP), 5 pins.

By default, the JTAG Debug Port is active. If the host debugger wants to switch to the Serial Wire Debug Port, it must provide a dedicated JTAG sequence on TMS/SWDIO and TCK/SWCLK which disables JTAG-DP and enables SW-DP.

When the Serial Wire Debug Port is active, TDO/TRACESWO can be used for trace. The asynchronous TRACE output (TRACESWO) is multiplexed with TDO. So the asynchronous trace can only be used with SW-DP, not JTAG-DP.

Table 12-2. SWJ-DP Pin List

Pin Name	JTAG Port	Serial Wire Debug Port
TMS/SWDIO	TMS	SWDIO
TCK/SWCLK	TCK	SWCLK
TDI	TDI	-
TDO/TRACESWO	TDO	TRACESWO (optional: trace)

SW-DP or JTAG-DP mode is selected when JTAGSEL is low. It is not possible to switch directly between SWJ-DP and JTAG boundary scan operations. A chip reset must be performed after JTAGSEL is changed.

12.5.3.1 SW-DP and JTAG-DP Selection Mechanism

Debug port selection mechanism is done by sending specific **SWDIOTMS** sequence. The JTAG-DP is selected by default after reset.

- Switch from JTAG-DP to SW-DP. The sequence is:
 - Send more than 50 **SWCLKTCK** cycles with **SWDIOTMS** = 1
 - Send the 16-bit sequence on **SWDIOTMS** = 0111100111100111 (0x79E7 MSB first)
 - Send more than 50 **SWCLKTCK** cycles with **SWDIOTMS** = 1
- Switch from SWD to JTAG. The sequence is:
 - Send more than 50 **SWCLKTCK** cycles with **SWDIOTMS** = 1
 - Send the 16-bit sequence on **SWDIOTMS** = 0011110011100111 (0x3CE7 MSB first)
 - Send more than 50 **SWCLKTCK** cycles with **SWDIOTMS** = 1

12.5.4 FPB (Flash Patch Breakpoint)

The FPB:

- Implements hardware breakpoints
- Patches code and data from code space to system space.

The FPB unit contains:

- Two literal comparators for matching against literal loads from Code space, and remapping to a corresponding area in System space.
- Six instruction comparators for matching against instruction fetches from Code space and remapping to a corresponding area in System space.
- Alternatively, comparators can also be configured to generate a Breakpoint instruction to the processor core on a match.

12.5.5 DWT (Data Watchpoint and Trace)

The DWT contains four comparators which can be configured to generate the following:

- PC sampling packets at set intervals
- PC or Data watchpoint packets

- Watchpoint event to halt core

The DWT contains counters for the items that follow:

- Clock cycle (CYCCNT)
- Folded instructions
- Load Store Unit (LSU) operations
- Sleep Cycles
- CPI (all instruction cycles except for the first cycle)
- Interrupt overhead

12.5.6 ITM (Instrumentation Trace Macrocell)

The ITM is an application driven trace source that supports printf style debugging to trace Operating System (OS) and application events, and emits diagnostic system information. The ITM emits trace information as packets which can be generated by three different sources with several priority levels:

- **Software trace:** Software can write directly to ITM stimulus registers. This can be done thanks to the “printf” function. For more information, refer to [Section 12.5.6.1 “How to Configure the ITM”](#).
- **Hardware trace:** The ITM emits packets generated by the DWT.
- **Time stamping:** Timestamps are emitted relative to packets. The ITM contains a 21-bit counter to generate the timestamp.

12.5.6.1 How to Configure the ITM

The following example describes how to output trace data in asynchronous trace mode.

- Configure the TPIU for asynchronous trace mode (refer to [Section 12.5.6.3 “5.4.3. How to Configure the TPIU”](#))
- Enable the write accesses into the ITM registers by writing “0xC5ACCE55” into the Lock Access Register (Address: 0xE0000FB0)
- Write 0x00010015 into the Trace Control Register:
 - Enable ITM
 - Enable Synchronization packets
 - Enable SWO behavior
 - Fix the ATB ID to 1

- Write 0x1 into the Trace Enable Register:

- Enable the Stimulus port 0

- Write 0x1 into the Trace Privilege Register:

- Stimulus port 0 only accessed in privileged mode (Clearing a bit in this register will result in the corresponding stimulus port being accessible in user mode.)

- Write into the Stimulus port 0 register: TPIU (Trace Port Interface Unit)

The TPIU acts as a bridge between the on-chip trace data and the Instruction Trace Macrocell (ITM).

The TPIU formats and transmits trace data off-chip at frequencies asynchronous to the core.

12.5.6.2 Asynchronous Mode

The TPIU is configured in asynchronous mode, trace data are output using the single TRACESWO pin. The TRACESWO signal is multiplexed with the TDO signal of the JTAG Debug Port. As a consequence, asynchronous trace mode is only available when the Serial Wire Debug mode is selected since TDO signal is used in JTAG debug mode.

Two encoding formats are available for the single pin output:

- Manchester encoded stream. This is the reset value.
- NRZ_based UART byte structure

12.5.6.3 5.4.3. How to Configure the TPIU

This example only concerns the asynchronous trace mode.

- Set the TRCENA bit to 1 into the Debug Exception and Monitor Register (0xE00EDFC) to enable the use of trace and debug blocks.
- Write 0x2 into the Selected Pin Protocol Register
 - Select the Serial Wire Output – NRZ
- Write 0x100 into the Formatter and Flush Control Register
- Set the suitable clock prescaler value into the Async Clock Prescaler Register to scale the baud rate of the asynchronous output (this can be done automatically by the debugging tool).

12.5.7 IEEE® 1149.1 JTAG Boundary Scan

IEEE 1149.1 JTAG Boundary Scan allows pin-level access independent of the device packaging technology.

IEEE 1149.1 JTAG Boundary Scan is enabled when TST is tied to low, while JTAGSEL is high during power-up, and must be kept in this state during the whole boundary scan operation. The SAMPLE, EXTEST and BYPASS functions are implemented. In SWD/JTAG debug mode, the ARM processor responds with a non-JTAG chip ID that identifies the processor. This is not IEEE 1149.1 JTAG-compliant.

It is not possible to switch directly between JTAG Boundary Scan and SWJ Debug Port operations. A chip reset must be performed after JTAGSEL is changed.

A Boundary-scan Descriptor Language (BSDL) file is provided on [Atmel's web site](#) to set up the test.

12.5.7.1 JTAG Boundary-scan Register

The Boundary-scan Register (BSR) contains a number of bits which correspond to active pins and associated control signals.

Each SAM4 input/output pin corresponds to a 3-bit register in the BSR. The OUTPUT bit contains data that can be forced on the pad. The INPUT bit facilitates the observability of data applied to the pad. The CONTROL bit selects the direction of the pad.

For more information, please refer to BSDL files available for the SAM4 Series.



12.5.8 ID Code Register

Access: Read-only

31	30	29	28	27	26	25	24
VERSION				PART NUMBER			
23	22	21	20	19	18	17	16
PART NUMBER							
15	14	13	12	11	10	9	8
PART NUMBER				MANUFACTURER IDENTITY			
7	6	5	4	3	2	1	0
MANUFACTURER IDENTITY							1

- **VERSION[31:28]: Product Version Number**

Set to 0x0.

- **PART NUMBER[27:12]: Product Part Number**

Chip Name	Chip ID
SAM4S	0x05B32

- **MANUFACTURER IDENTITY[11:1]**

Set to 0x01F.

- **Bit[0] Required by IEEE Std. 1149.1.**

Set to 0x1.

Chip Name	JTAG ID Code
SAM4S	0x05B3203F

13. Reset Controller (RSTC)

13.1 Description

The Reset Controller (RSTC), based on power-on reset cells, handles all the resets of the system without any external components. It reports which reset occurred last.

The Reset Controller also drives independently or simultaneously the external reset and the peripheral and processor resets.

13.2 Embedded Characteristics

- Manages all Resets of the System, Including
 - External Devices through the NRST Pin
 - Processor Reset
 - Peripheral Set Reset
- Based on Embedded Power-on Cell
- Reset Source Status
 - Status of the Last Reset
 - Either Software Reset, User Reset, Watchdog Reset
- External Reset Signal Shaping

13.3 Block Diagram

Figure 13-1. Reset Controller Block Diagram

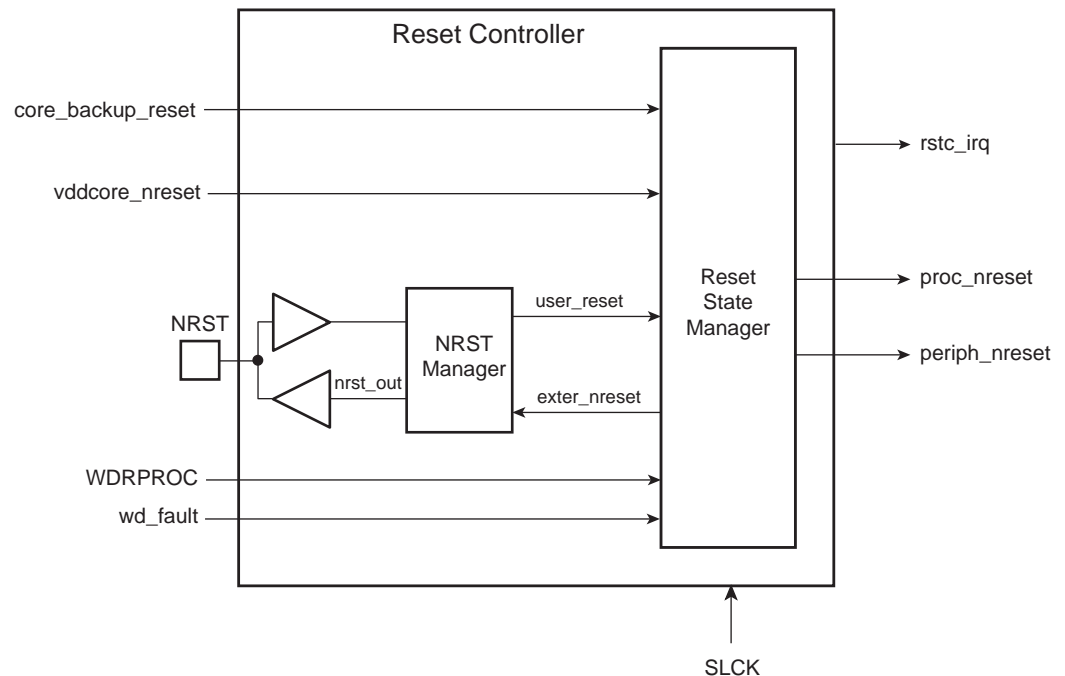

13.4 Functional Description

13.4.1 Reset Controller Overview

The Reset Controller is made up of an NRST Manager and a Reset State Manager. It runs at Slow Clock and generates the following reset signals:

- `proc_nreset`: Processor reset line. It also resets the Watchdog Timer
- `periph_nreset`: Affects the whole set of embedded peripherals
- `nrst_out`: Drives the NRST pin

These reset signals are asserted by the Reset Controller, either on external events or on software action. The Reset State Manager controls the generation of reset signals and provides a signal to the NRST Manager when an assertion of the NRST pin is required.

The NRST Manager shapes the NRST assertion during a programmable time, thus controlling external device resets.

The Reset Controller Mode Register (`RSTC_MR`), allowing the configuration of the Reset Controller, is powered with `VDDIO`, so that its configuration is saved as long as `VDDIO` is on.

13.4.2 NRST Manager

After power-up, NRST is an output during the `ERSTL` time period defined in the `RSTC_MR`. When `ERSTL` has elapsed, the pin behaves as an input and all the system is held in reset if NRST is tied to GND by an external signal.

The NRST Manager samples the NRST input pin and drives this pin low when required by the Reset State Manager. [Figure 13-2](#) shows the block diagram of the NRST Manager.

Figure 13-2. NRST Manager

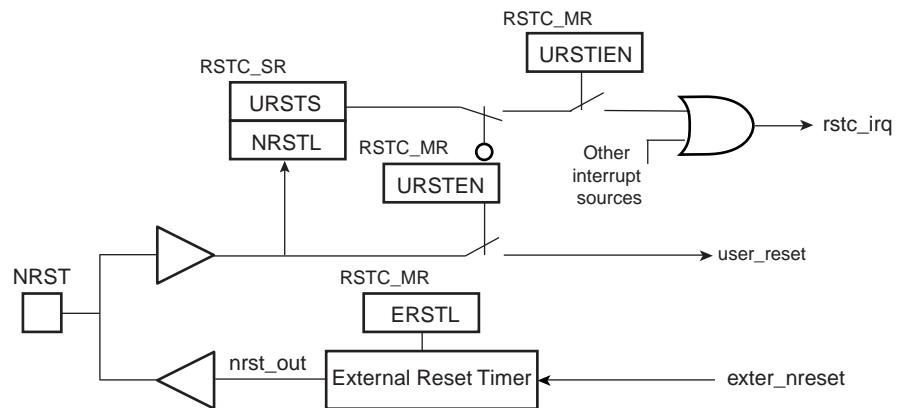

13.4.2.1 NRST Signal or Interrupt

The NRST Manager samples the NRST pin at Slow Clock speed. When the line is detected low, a User Reset is reported to the Reset State Manager.

However, the NRST Manager can be programmed to not trigger a reset when an assertion of NRST occurs. Writing the bit `URSTEN` at 0 in `RSTC_MR` disables the User Reset trigger.

The level of the pin NRST can be read at any time in the bit NRSTL (NRST level) in RSTC_SR. As soon as the pin NRST is asserted, the bit URSTS in RSTC_SR is set. This bit clears only when RSTC_SR is read.

The Reset Controller can also be programmed to generate an interrupt instead of generating a reset. To do so, the bit URSTIEN in RSTC_MR must be written at 1.

13.4.2.2 NRST External Reset Control

The Reset State Manager asserts the signal ext_nreset to assert the NRST pin. When this occurs, the “nrst_out” signal is driven low by the NRST Manager for a time programmed by the field ERSTL in RSTC_MR. This assertion duration, named EXTERNAL_RESET_LENGTH, lasts $2^{(ERSTL+1)}$ Slow Clock cycles. This gives the approximate duration of an assertion between 60 μ s and 2 seconds. Note that ERSTL at 0 defines a two-cycle duration for the NRST pulse.

This feature allows the Reset Controller to shape the NRST pin level, and thus to guarantee that the NRST line is driven low for a time compliant with potential external devices connected on the system reset.

As the ERSTL field is within RSTC_MR register, which is backed-up, it can be used to shape the system power-up reset for devices requiring a longer startup time than the Slow Clock Oscillator.

13.4.3 Brownout Manager

The Brownout manager is embedded within the Supply Controller, please refer to the product Supply Controller section for a detailed description.

13.4.4 Reset States

The Reset State Manager handles the different reset sources and generates the internal reset signals. It reports the reset status in the field RSTTYP of the Status Register (RSTC_SR). The update of the field RSTTYP is performed when the processor reset is released.

13.4.4.1 General Reset

A general reset occurs when a Power-on-reset is detected, a Brownout or a Voltage regulation loss is detected by the Supply controller. The vddcore_nreset signal is asserted by the Supply Controller when a general reset occurs.

All the reset signals are released and the field RSTTYP in RSTC_SR reports a General Reset. As the RSTC_MR is reset, the NRST line rises 2 cycles after the vddcore_nreset, as ERSTL defaults at value 0x0.

Figure 13-3 shows how the General Reset affects the reset signals.

Figure 13-3. General Reset State

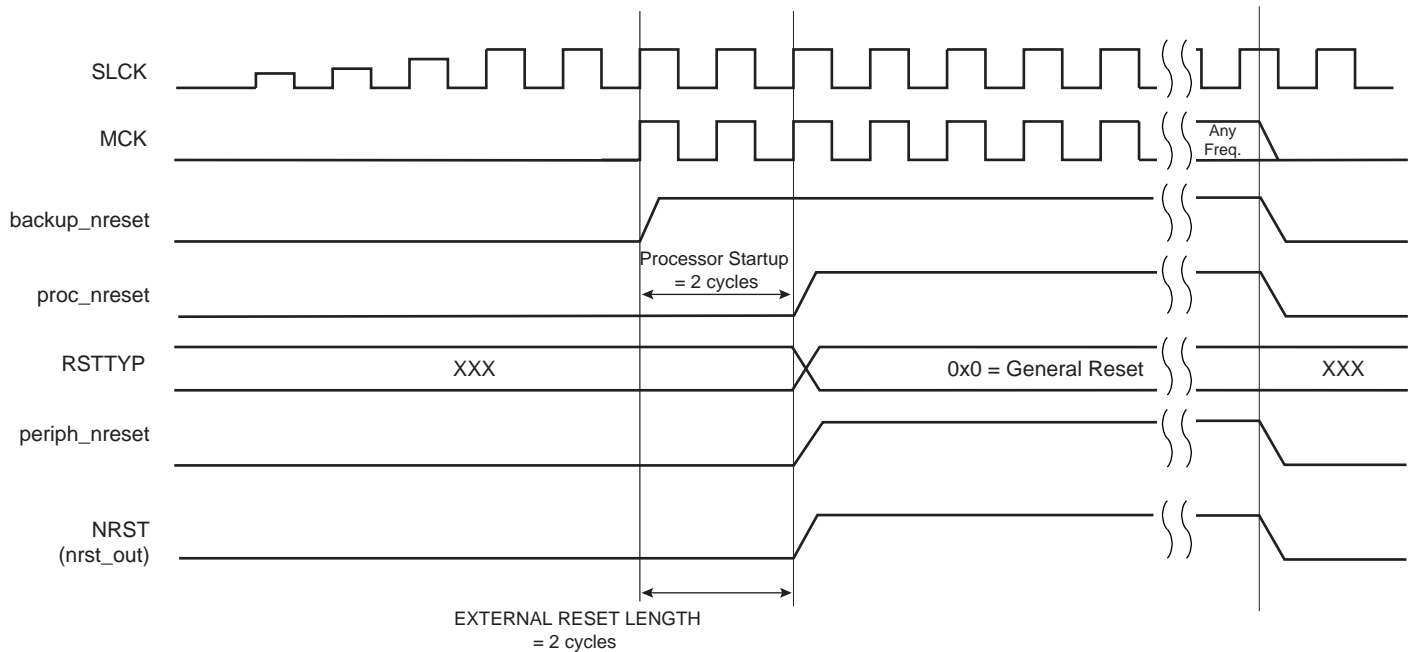

13.4.4.2 Backup Reset

A Backup reset occurs when the chip returns from Backup Mode. The `core_backup_reset` signal is asserted by the Supply Controller when a Backup reset occurs.

The field `RSTTYP` in `RSTC_SR` is updated to report a Backup Reset.

13.4.4.3 User Reset

The User Reset is entered when a low level is detected on the `NRST` pin and the bit `URSTEN` in `RSTC_MR` is at 1. The `NRST` input signal is resynchronized with `SLCK` to insure proper behavior of the system.

The User Reset is entered as soon as a low level is detected on `NRST`. The Processor Reset and the Peripheral Reset are asserted.

The User Reset is left when `NRST` rises, after a two-cycle resynchronization time and a 3-cycle processor startup. The processor clock is re-enabled as soon as `NRST` is confirmed high.

When the processor reset signal is released, the `RSTTYP` field of the Status Register (`RSTC_SR`) is loaded with the value `0x4`, indicating a User Reset.

The `NRST` Manager guarantees that the `NRST` line is asserted for `EXTERNAL_RESET_LENGTH` Slow Clock cycles, as programmed in the field `ERSTL`. However, if `NRST` does not rise after `EXTERNAL_RESET_LENGTH` because it is driven low externally, the internal reset lines remain asserted until `NRST` actually rises.

Figure 13-4. User Reset State

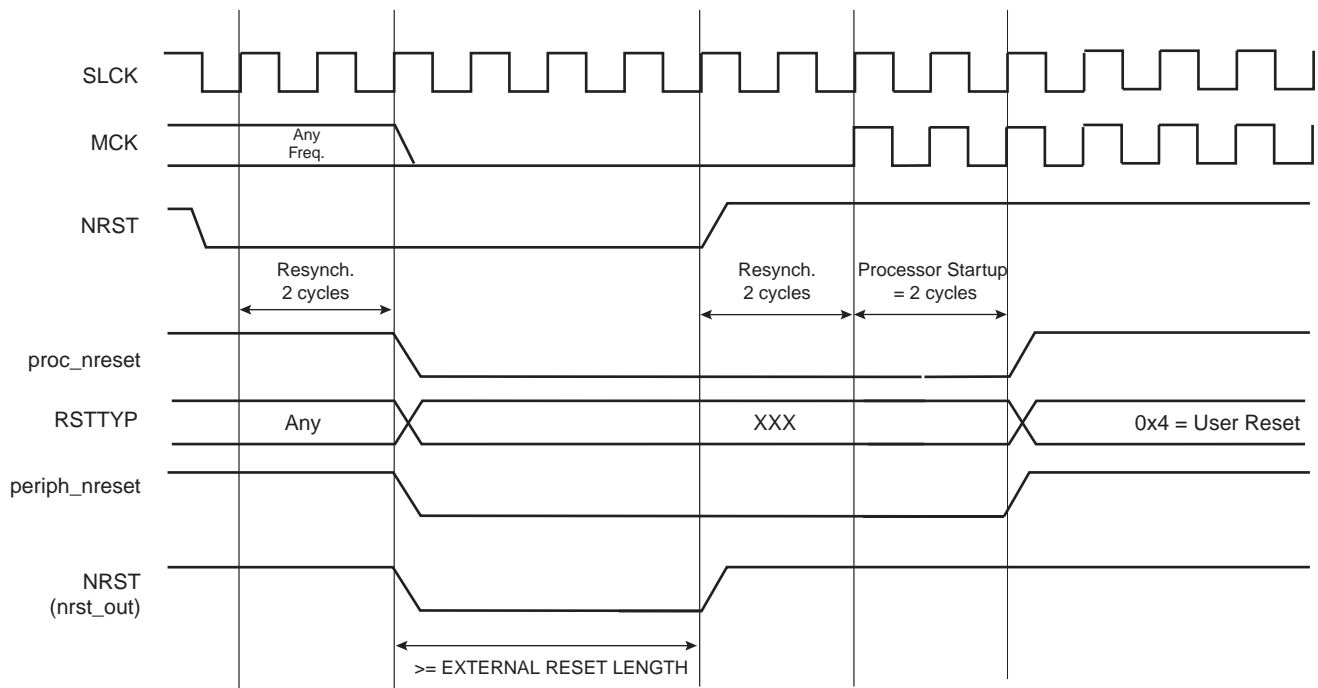

13.4.4.4 Software Reset

The Reset Controller offers several commands used to assert the different reset signals. These commands are performed by writing the Control Register (RSTC_CR) with the following bits at 1:

- **PROCRST:** Writing PROCRST at 1 resets the processor and the watchdog timer
- **PERRST:** Writing PERRST at 1 resets all the embedded peripherals including the memory system, and, in particular, the Remap Command. The Peripheral Reset is generally used for debug purposes.
Except for debug purposes, PERRST must always be used in conjunction with PROCRST (PERRST and PROCRST set both at 1 simultaneously).
- **EXTRST:** Writing EXTRST at 1 asserts low the NRST pin during a time defined by the field ERSTL in the Mode Register (RSTC_MR).

The software reset is entered if at least one of these bits is set by the software. All these commands can be performed independently or simultaneously. The software reset lasts 3 Slow Clock cycles.

The internal reset signals are asserted as soon as the register write is performed. This is detected on the Master Clock (MCK). They are released when the software reset is left, i.e.; synchronously to SLCK.

If EXTRST is set, the nrst_out signal is asserted depending on the programming of the field ERSTL. However, the resulting falling edge on NRST does not lead to a User Reset.

If and only if the PROCRST bit is set, the Reset Controller reports the software status in the field RSTTYP of the Status Register (RSTC_SR). Other Software Resets are not reported in RSTTYP.

As soon as a software operation is detected, the bit SRCMP (Software Reset Command in Progress) is set in the Status Register (RSTC_SR). It is cleared as soon as the software reset is left. No other software reset can be performed while the SRCMP bit is set, and writing any value in RSTC_CR has no effect.

Figure 13-5. Software Reset

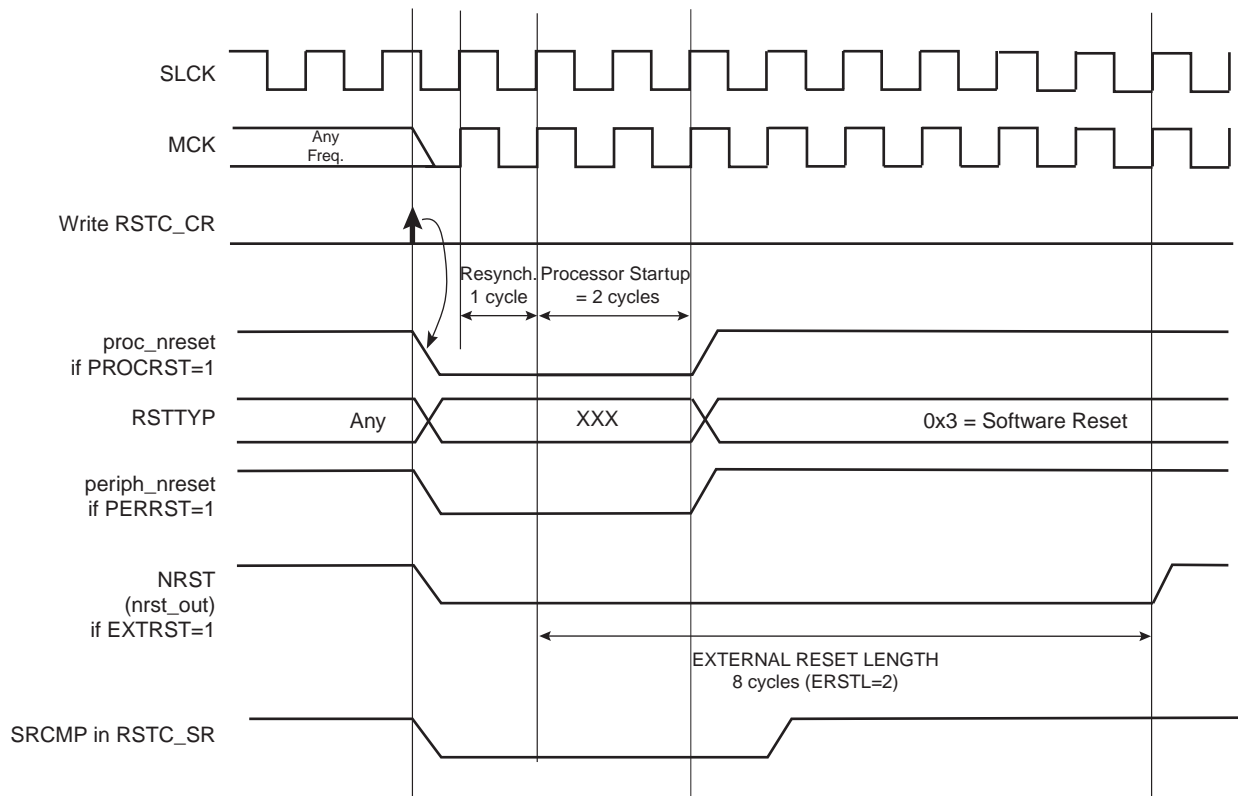

13.4.4.5 Watchdog Reset

The Watchdog Reset is entered when a watchdog fault occurs. This state lasts 3 Slow Clock cycles.

When in Watchdog Reset, assertion of the reset signals depends on the WDRPROC bit in WDT_MR:

- If WDRPROC is 0, the Processor Reset and the Peripheral Reset are asserted. The NRST line is also asserted, depending on the programming of the field ERSTL. However, the resulting low level on NRST does not result in a User Reset state.
- If WDRPROC = 1, only the processor reset is asserted.

The Watchdog Timer is reset by the proc_nreset signal. As the watchdog fault always causes a processor reset if WDRSTEN is set, the Watchdog Timer is always reset after a Watchdog Reset, and the Watchdog is enabled by default and with a period set to a maximum.

When the WDRSTEN in WDT_MR bit is reset, the watchdog fault has no impact on the reset controller.

Figure 13-6. Watchdog Reset

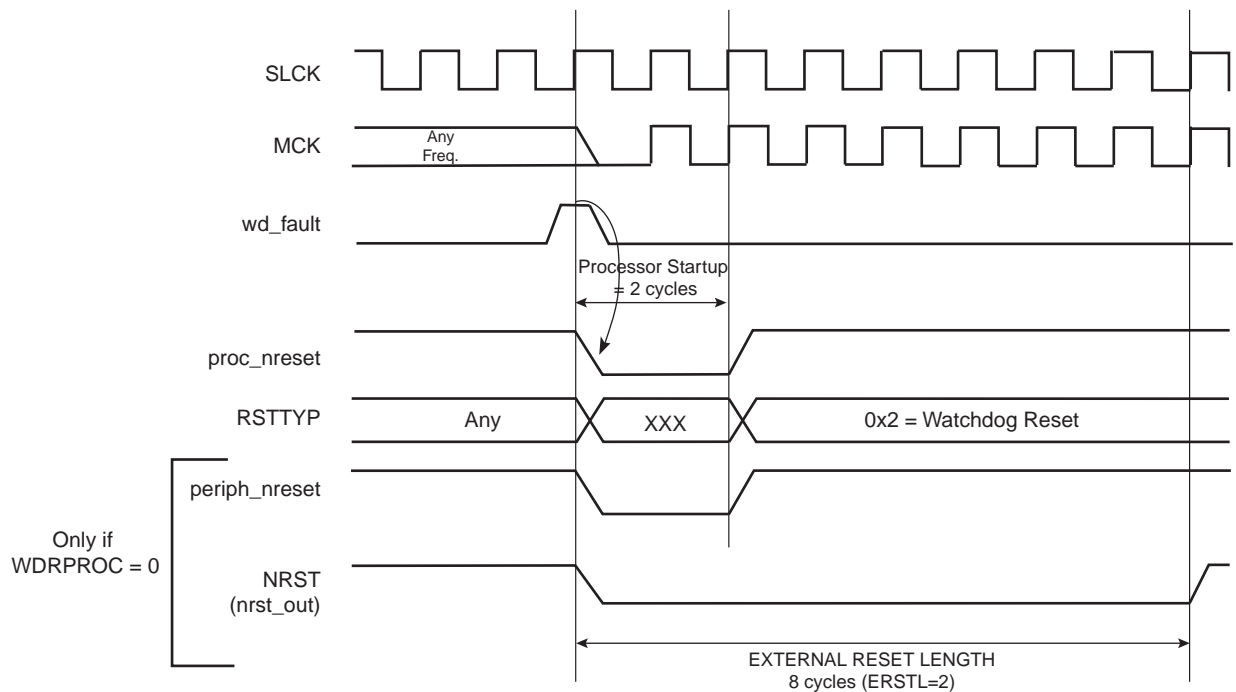

13.4.5 Reset State Priorities

The Reset State Manager manages the following priorities between the different reset sources, given in descending order:

- General Reset
- Backup Reset
- Watchdog Reset
- Software Reset
- User Reset

Particular cases are listed below:

- When in User Reset:
 - A watchdog event is impossible because the Watchdog Timer is being reset by the `proc_nreset` signal.
 - A software reset is impossible, since the processor reset is being activated.
- When in Software Reset:
 - A watchdog event has priority over the current state.
 - The NRST has no effect.
- When in Watchdog Reset:
 - The processor reset is active and so a Software Reset cannot be programmed.
 - A User Reset cannot be entered.

13.4.6 Reset Controller Status Register

The Reset Controller status register (RSTC_SR) provides several status fields:

- RSTTYP field: This field gives the type of the last reset, as explained in previous sections.
- SRCMP bit: This field indicates that a Software Reset Command is in progress and that no further software reset should be performed until the end of the current one. This bit is automatically cleared at the end of the current software reset.
- NRSTL bit: The NRSTL bit of the Status Register gives the level of the NRST pin sampled on each MCK rising edge.
- URSTS bit: A high-to-low transition of the NRST pin sets the URSTS bit of the RSTC_SR register. This transition is also detected on the Master Clock (MCK) rising edge (see [Figure 13-7](#)). If the User Reset is disabled (URSTEN = 0) and if the interruption is enabled by the URSTIEN bit in the RSTC_MR register, the URSTS bit triggers an interrupt. Reading the RSTC_SR status register resets the URSTS bit and clears the interrupt.

Figure 13-7. Reset Controller Status and Interrupt

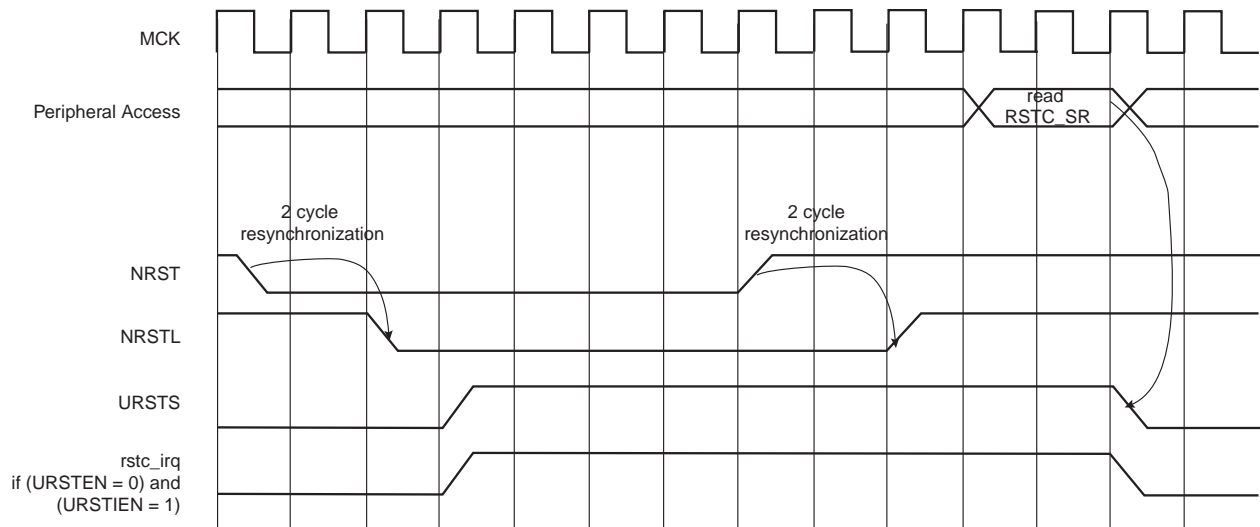

13.5 Reset Controller (RSTC) User Interface**Table 13-1.** Register Mapping

Offset	Register	Name	Access	Reset
0x00	Control Register	RSTC_CR	Write-only	-
0x04	Status Register	RSTC_SR	Read-only	0x0000_0000
0x08	Mode Register	RSTC_MR	Read-write	0x0000 0001

13.5.1 Reset Controller Control Register

Name: RSTC_CR
Address: 0x400E1400
Access: Write-only

31	30	29	28	27	26	25	24
KEY							
23	22	21	20	19	18	17	16
-	-	-	-	-	-	-	-
15	14	13	12	11	10	9	8
-	-	-	-	-	-	-	-
7	6	5	4	3	2	1	0
-	-	-	-	EXTRST	PERRST	-	PROCRST

- **PROCRST: Processor Reset**

0 = No effect.

1 = If KEY is correct, resets the processor.

- **PERRST: Peripheral Reset**

0 = No effect.

1 = If KEY is correct, resets the peripherals.

- **EXTRST: External Reset**

0 = No effect.

1 = If KEY is correct, asserts the NRST pin and resets the processor and the peripherals.

- **KEY: System Reset Key**

Should be written at value 0xA5. Writing any other value in this field aborts the write operation.

13.5.2 Reset Controller Status Register

Name: RSTC_SR
Address: 0x400E1404
Access: Read-only

31	30	29	28	27	26	25	24
–	–	–	–	–	–	–	–
23	22	21	20	19	18	17	16
–	–	–	–	–	–	SRCMP	NRSTL
15	14	13	12	11	10	9	8
–	–	–	–	–	RSTTYP		
7	6	5	4	3	2	1	0
–	–	–	–	–	–	–	URSTS

- **URSTS: User Reset Status**

0 = No high-to-low edge on NRST happened since the last read of RSTC_SR.

1 = At least one high-to-low transition of NRST has been detected since the last read of RSTC_SR.

- **RSTTYP: Reset Type**

Reports the cause of the last processor reset. Reading this RSTC_SR does not reset this field.

RSTTYP			Reset Type	Comments
0	0	0	General Reset	First power-up Reset
0	0	1	Backup Reset	Return from Backup Mode
0	1	0	Watchdog Reset	Watchdog fault occurred
0	1	1	Software Reset	Processor reset required by the software
1	0	0	User Reset	NRST pin detected low

- **NRSTL: NRST Pin Level**

Registers the NRST Pin Level at Master Clock (MCK).

- **SRCMP: Software Reset Command in Progress**

0 = No software command is being performed by the reset controller. The reset controller is ready for a software command.

1 = A software reset command is being performed by the reset controller. The reset controller is busy.

13.5.3 Reset Controller Mode Register

Name: RSTC_MR
Address: 0x400E1408
Access: Read-write

31	30	29	28	27	26	25	24
KEY							
23	22	21	20	19	18	17	16
-	-	-	-	-	-	-	-
15	14	13	12	11	10	9	8
-	-	-	-	ERSTL			
7	6	5	4	3	2	1	0
-	-		URSTIEN	-	-	-	URSTEN

- **URSTEN: User Reset Enable**

0 = The detection of a low level on the pin NRST does not generate a User Reset.

1 = The detection of a low level on the pin NRST triggers a User Reset.

- **URSTIEN: User Reset Interrupt Enable**

0 = USRTS bit in RSTC_SR at 1 has no effect on rstc_irq.

1 = USRTS bit in RSTC_SR at 1 asserts rstc_irq if URSTEN = 0.

- **ERSTL: External Reset Length**

This field defines the external reset length. The external reset is asserted during a time of $2^{(ERSTL+1)}$ Slow Clock cycles. This allows assertion duration to be programmed between 60 μ s and 2 seconds.

- **KEY: Password**

Should be written at value 0xA5. Writing any other value in this field aborts the write operation.

14. Real-time Timer (RTT)

14.1 Description

The Real-time Timer (RTT) is built around a 32-bit counter used to count roll-over events of the programmable 16-bit prescaler which enables counting elapsed seconds from a 32 kHz slow clock source. It generates a periodic interrupt and/or triggers an alarm on a programmed value.

14.2 Embedded Characteristics

- 32-bit Free-running back-up counter
- Integrates a 16-bit programmable prescaler running on slow clock
- Alarm Register capable to generate a wake-up of the system through the Shut Down Controller

14.3 Block Diagram

Figure 14-1. Real-time Timer

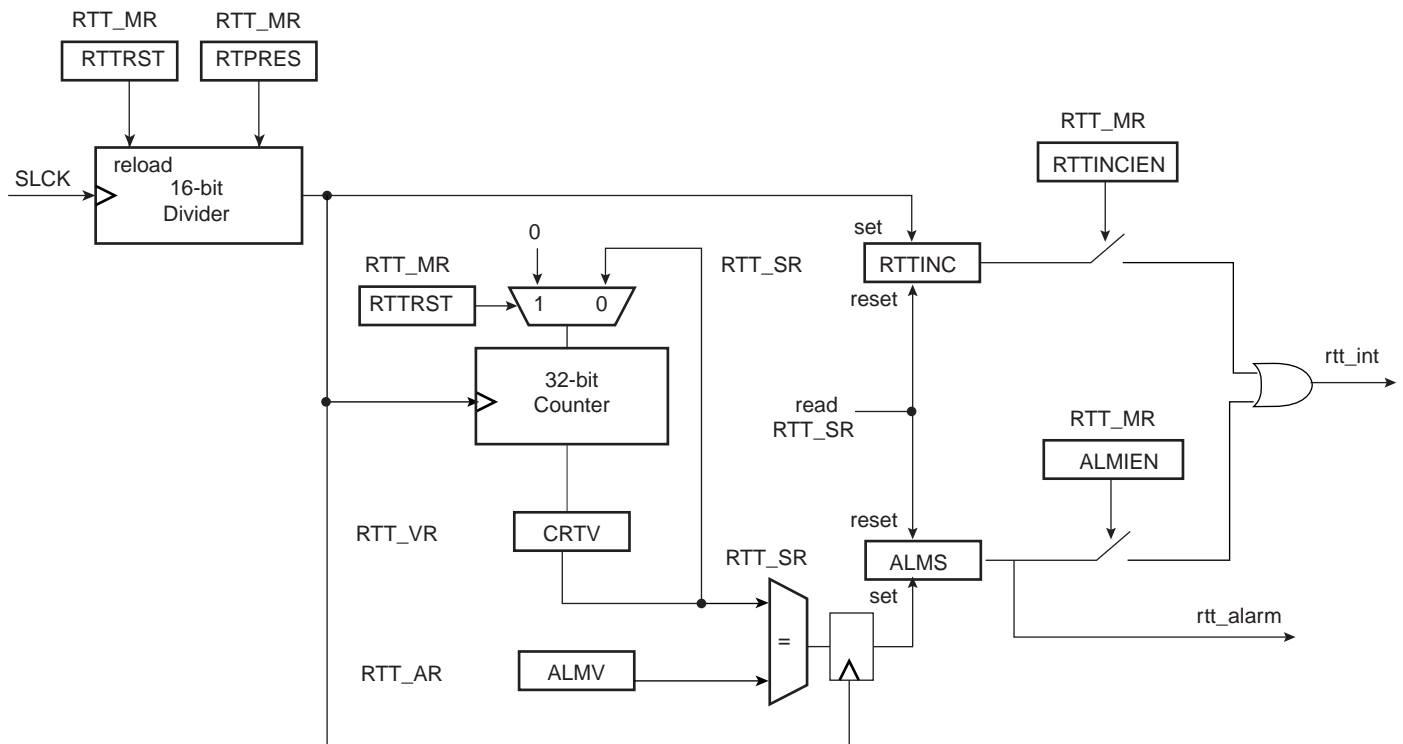

14.4 Functional Description

The Real-time Timer can be used to count elapsed seconds. It is built around a 32-bit counter fed by Slow Clock divided by a programmable 16-bit value. The value can be programmed in the field RTPRES of the Real-time Mode Register (RTT_MR).

Programming RTPRES at 0x00008000 corresponds to feeding the real-time counter with a 1 Hz signal (if the Slow Clock is 32.768 kHz). The 32-bit counter can count up to 2^{32} seconds, corresponding to more than 136 years, then roll over to 0.

The Real-time Timer can also be used as a free-running timer with a lower time-base. The best accuracy is achieved by writing RTPRES to 3. Programming RTPRES to 1 or 2 is possible, but may result in losing status events because the status register is cleared two Slow Clock cycles after read. Thus if the RTT is configured to trigger an interrupt, the interrupt occurs during 2 Slow Clock cycles after reading RTT_SR. To prevent several executions of the interrupt handler, the interrupt must be disabled in the interrupt handler and re-enabled when the status register is clear.

The Real-time Timer value (CRTV) can be read at any time in the register RTT_VR (Real-time Value Register). As this value can be updated asynchronously from the Master Clock, it is advisable to read this register twice at the same value to improve accuracy of the returned value.

The current value of the counter is compared with the value written in the alarm register RTT_AR (Real-time Alarm Register). If the counter value matches the alarm, the bit ALMS in RTT_SR is set. The alarm register is set to its maximum value, corresponding to 0xFFFF_FFFF, after a reset.

The bit RTTINC in RTT_SR is set each time the Real-time Timer counter is incremented. This bit can be used to start a periodic interrupt, the period being one second when the RTPRES is programmed with 0x8000 and Slow Clock equal to 32.768 Hz.

Reading the RTT_SR status register resets the RTTINC and ALMS fields.

Writing the bit RTRRST in RTT_MR immediately reloads and restarts the clock divider with the new programmed value. This also resets the 32-bit counter.

Note: Because of the asynchronism between the Slow Clock (SCLK) and the System Clock (MCK):

- 1) The restart of the counter and the reset of the RTT_VR current value register is effective only 2 slow clock cycles after the write of the RTRRST bit in the RTT_MR register.
- 2) The status register flags reset is taken into account only 2 slow clock cycles after the read of the RTT_SR (Status Register).

Figure 14-2. RTT Counting

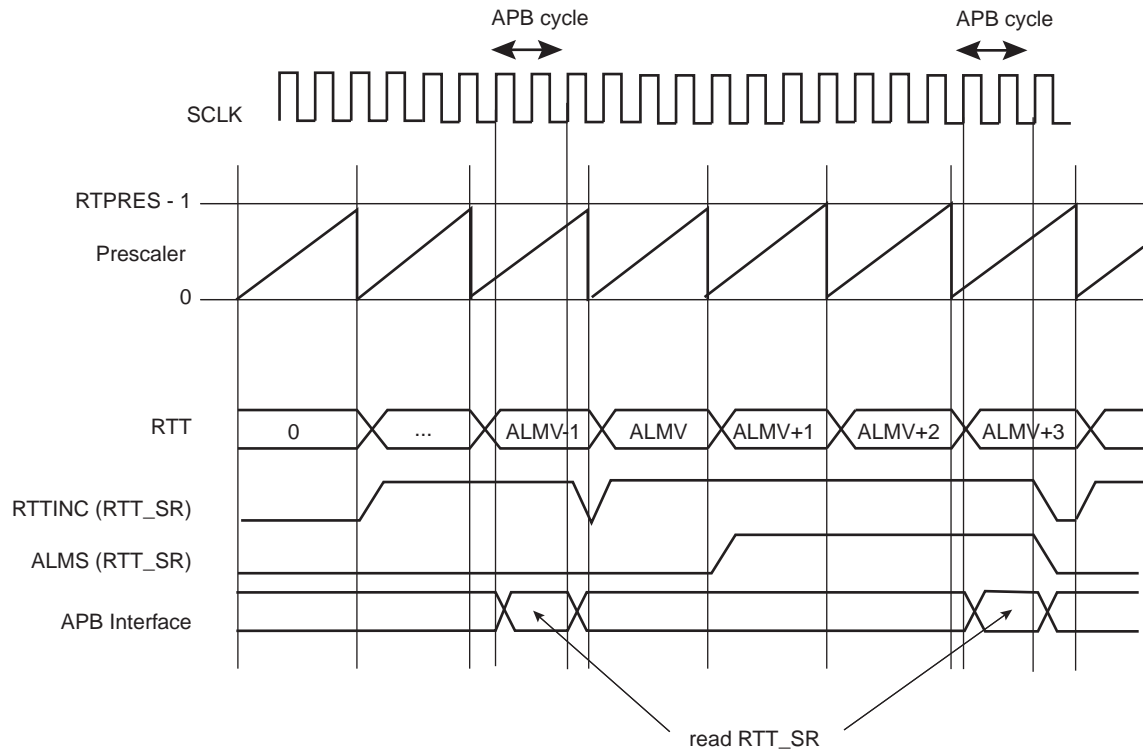

14.5 Real-Time Timer (RTT) User Interface

Table 14-1. Register Mapping

Offset	Register	Name	Access	Reset
0x00	Mode Register	RTT_MR	Read-write	0x0000_8000
0x04	Alarm Register	RTT_AR	Read-write	0xFFFF_FFFF
0x08	Value Register	RTT_VR	Read-only	0x0000_0000
0x0C	Status Register	RTT_SR	Read-only	0x0000_0000

14.5.1 Real-time Timer Mode Register

Name: RTT_MR
Address: 0x400E1430
Access: Read-write

31	30	29	28	27	26	25	24
–	–	–	–	–	–	–	–
23	22	21	20	19	18	17	16
–	–	–	–	–	RTRRST	RTTINCIEN	ALMIEN
15	14	13	12	11	10	9	8
RTPRES							
7	6	5	4	3	2	1	0
RTPRES							

- **RTPRES: Real-time Timer Prescaler Value**

Defines the number of SLCK periods required to increment the Real-time timer. RTPRES is defined as follows:

RTPRES = 0: The prescaler period is equal to $2^{16} * SCLK$ period.

RTPRES \neq 0: The prescaler period is equal to RTPRES * SCLK period.

- **ALMIEN: Alarm Interrupt Enable**

0 = The bit ALMS in RTT_SR has no effect on interrupt.

1 = The bit ALMS in RTT_SR asserts interrupt.

- **RTTINCIEN: Real-time Timer Increment Interrupt Enable**

0 = The bit RTTINC in RTT_SR has no effect on interrupt.

1 = The bit RTTINC in RTT_SR asserts interrupt.

- **RTRRST: Real-time Timer Restart**

0 = No effect.

1 = Reloads and restarts the clock divider with the new programmed value. This also resets the 32-bit counter.

14.5.2 Real-time Timer Alarm Register

Name: RTT_AR

Address: 0x400E1434

Access: Read-write

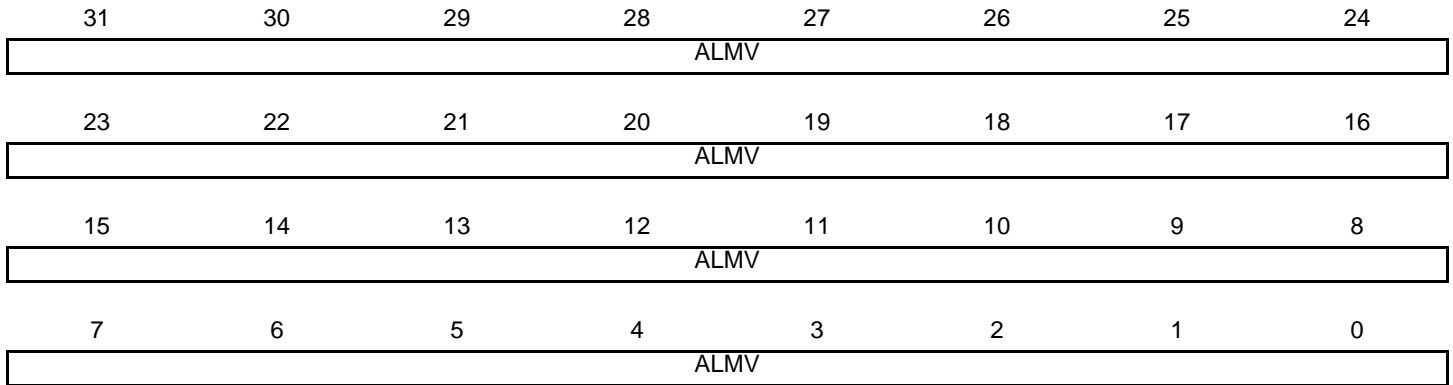

- **ALMV: Alarm Value**

Defines the alarm value (ALMV+1) compared with the Real-time Timer.

14.5.3 Real-time Timer Value Register

Name: RTT_VR

Address: 0x400E1438

Access: Read-only

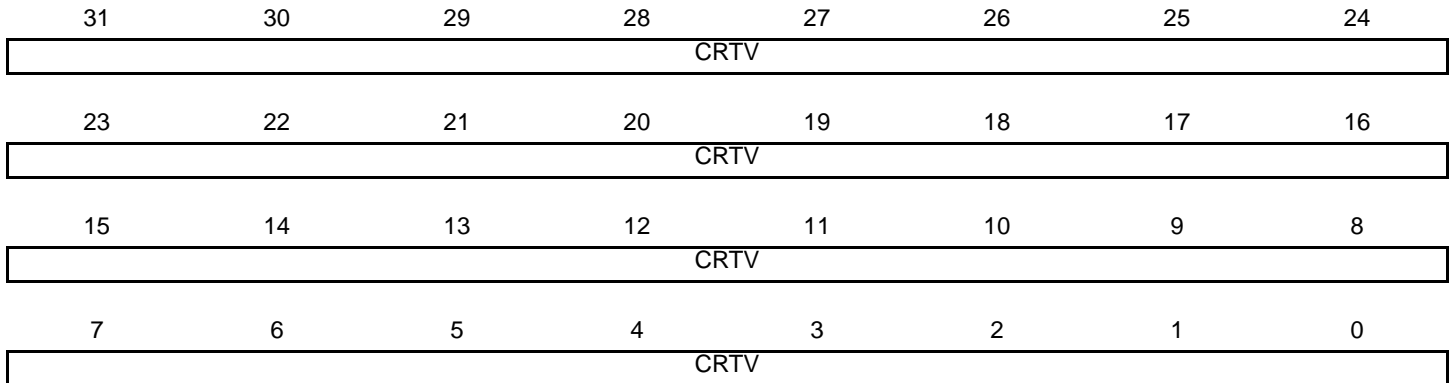

- **CRTV: Current Real-time Value**

Returns the current value of the Real-time Timer.

14.5.4 Real-time Timer Status Register

Name: RTT_SR

Address: 0x400E143C

Access: Read-only

31	30	29	28	27	26	25	24
–	–	–	–	–	–	–	–
23	22	21	20	19	18	17	16
–	–	–	–	–	–	–	–
15	14	13	12	11	10	9	8
–	–	–	–	–	–	–	–
7	6	5	4	3	2	1	0
–	–	–	–	–	–	RTTINC	ALMS

- **ALMS: Real-time Alarm Status**

0 = The Real-time Alarm has not occurred since the last read of RTT_SR.

1 = The Real-time Alarm occurred since the last read of RTT_SR.

- **RTTINC: Real-time Timer Increment**

0 = The Real-time Timer has not been incremented since the last read of the RTT_SR.

1 = The Real-time Timer has been incremented since the last read of the RTT_SR.

15. Real Time Clock (RTC)

15.1 Description

The Real-Time Clock (RTC) peripheral is designed for very low power consumption.

It combines a complete time-of-day clock with alarm and a two-hundred-year Gregorian or Persian calendar, complemented by a programmable periodic interrupt. The alarm and calendar registers are accessed by a 32-bit data bus.

The time and calendar values are coded in binary-coded decimal (BCD) format. The time format can be 24-hour mode or 12-hour mode with an AM/PM indicator.

Updating time and calendar fields and configuring the alarm fields are performed by a parallel capture on the 32-bit data bus. An entry control is performed to avoid loading registers with incompatible BCD format data or with an incompatible date according to the current month/year/century.

A clock divider calibration circuitry enables to compensate crystal oscillator frequency inaccuracy.

An RTC output can be programmed to generate several waveforms, including a prescaled clock derived from 32.768 KHz

15.2 Embedded Characteristics

- Ultra Low Power Consumption
- Full Asynchronous Design
- Gregorian Calendar up to 2099 or Persian Calendar
- Programmable Periodic Interrupt
- Valid Time and Date Programmation Check
- On-The-Fly Time and Date Validity Check
- Crystal Oscillator Clock Calibration
- Waveform Generation

15.3 Block Diagram

Figure 15-1. RTC Block Diagram

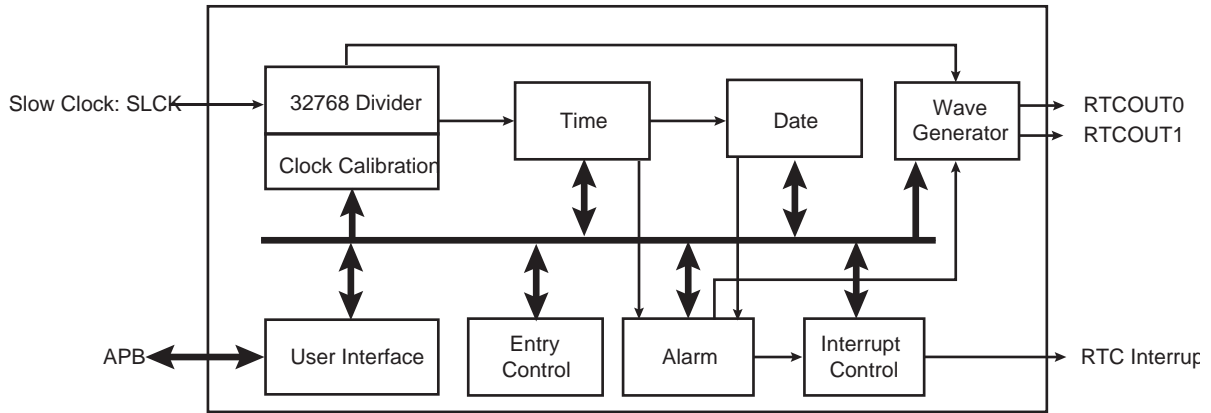

15.4 Product Dependencies

15.4.1 Power Management

The Real-time Clock is continuously clocked at 32768 Hz. The Power Management Controller has no effect on RTC behavior.

15.4.2 Interrupt

RTC interrupt line is connected on one of the internal sources of the interrupt controller. RTC interrupt requires the interrupt controller to be programmed first.

15.5 Functional Description

The RTC provides a full binary-coded decimal (BCD) clock that includes century (19/20), year (with leap years), month, date, day, hours, minutes and seconds.

The valid year range is 1900 to 2099 in Gregorian mode, a two-hundred-year calendar. (Or 1300 to 1499 in Persian mode.)

The RTC can operate in 24-hour mode or in 12-hour mode with an AM/PM indicator.

Corrections for leap years are included (all years divisible by 4 being leap years). This is correct up to the year 2099.

15.5.1 Reference Clock

The reference clock is Slow Clock (SLCK). It can be driven internally or by an external 32.768 kHz crystal.

During low power modes of the processor, the oscillator runs and power consumption is critical. The crystal selection has to take into account the current consumption for power saving and the frequency drift due to temperature effect on the circuit for time accuracy.

15.5.2 Timing

The RTC is updated in real time at one-second intervals in normal mode for the counters of seconds, at one-minute intervals for the counter of minutes and so on.

Due to the asynchronous operation of the RTC with respect to the rest of the chip, to be certain that the value read in the RTC registers (century, year, month, date, day, hours, minutes, seconds) are valid and stable, it is necessary to read these registers twice. If the data is the same both times, then it is valid. Therefore, a minimum of two and a maximum of three accesses are required.

15.5.3 Alarm

The RTC has five programmable fields: month, date, hours, minutes and seconds.

Each of these fields can be enabled or disabled to match the alarm condition:

- If all the fields are enabled, an alarm flag is generated (the corresponding flag is asserted and an interrupt generated if enabled) at a given month, date, hour/minute/second.
- If only the “seconds” field is enabled, then an alarm is generated every minute.

Depending on the combination of fields enabled, a large number of possibilities are available to the user ranging from minutes to 365/366 days.

15.5.4 Error Checking when Programming

Verification on user interface data is performed when accessing the century, year, month, date, day, hours, minutes, seconds and alarms. A check is performed on illegal BCD entries such as illegal date of the month with regard to the year and century configured.

If one of the time fields is not correct, the data is not loaded into the register/counter and a flag is set in the validity register. The user can not reset this flag. It is reset as soon as an acceptable value is programmed. This avoids any further side effects in the hardware. The same procedure is done for the alarm.

The following checks are performed:

1. Century (check if it is in range 19 - 20 or 13-14 in Persian mode)
2. Year (BCD entry check)
3. Date (check range 01 - 31)
4. Month (check if it is in BCD range 01 - 12, check validity regarding "date")
5. Day (check range 1 - 7)
6. Hour (BCD checks: in 24-hour mode, check range 00 - 23 and check that AM/PM flag is not set if RTC is set in 24-hour mode; in 12-hour mode check range 01 - 12)
7. Minute (check BCD and range 00 - 59)
8. Second (check BCD and range 00 - 59)

Note: If the 12-hour mode is selected by means of the RTC_MR register, a 12-hour value can be programmed and the returned value on RTC_TIMR will be the corresponding 24-hour value. The entry control checks the value of the AM/PM indicator (bit 22 of RTC_TIMR register) to determine the range to be checked.

15.5.5 RTC Internal Free Running Counter Error Checking

To improve the reliability and security of the RTC, a permanent check is performed on the internal free running counters to report non-BCD or invalid date/time values.

An error is reported by TDERR bit in the status register (RTC_SR) if an incorrect value has been detected. The flag can be cleared by programming the TDERRCLR in the RTC status clear control register (RTC_SCCR).

Anyway the TDERR error flag will be set again if the source of the error has not been cleared before clearing the TDERR flag. The clearing of the source of such error can be done either by reprogramming a correct value on RTC_CALR and/or RTC_TIMR registers.

The RTC internal free running counters may automatically clear the source of TDERR due to their roll-over (i.e. every 10 seconds for SECONDS[3:0] bitfield in RTC_TIMR register). In this case the TDERR is held high until a clear command is asserted by TDERRCLR bit in RTC_SCCR register.

15.5.6 Updating Time/Calendar

To update any of the time/calendar fields, the user must first stop the RTC by setting the corresponding field in the Control Register. Bit UPDTIM must be set to update time fields (hour, minute, second) and bit UPDCAL must be set to update calendar fields (century, year, month, date, day).

Then the user must poll or wait for the interrupt (if enabled) of bit ACKUPD in the Status Register. Once the bit reads 1, it is mandatory to clear this flag by writing the corresponding bit in RTC_SCCR. The user can now write to the appropriate Time and Calendar register.

Once the update is finished, the user must reset (0) UPDTIM and/or UPDCAL in the Control

When entering programming mode of the calendar fields, the time fields remain enabled. When entering the programming mode of the time fields, both time and calendar fields are stopped. This is due to the location of the calendar logic circuitry (downstream for low-power considerations). It is highly recommended to prepare all the fields to be updated before entering programming mode. In successive update operations, the user must wait at least one second after resetting the UPDTIM/UPDCAL bit in the RTC_CR (Control Register) before setting these bits again. This is done by waiting for the SEC flag in the Status Register before setting UPDTIM/UPDCAL bit. After resetting UPDTIM/UPDCAL, the SEC flag must also be cleared.

Figure 15-2. Update Sequence

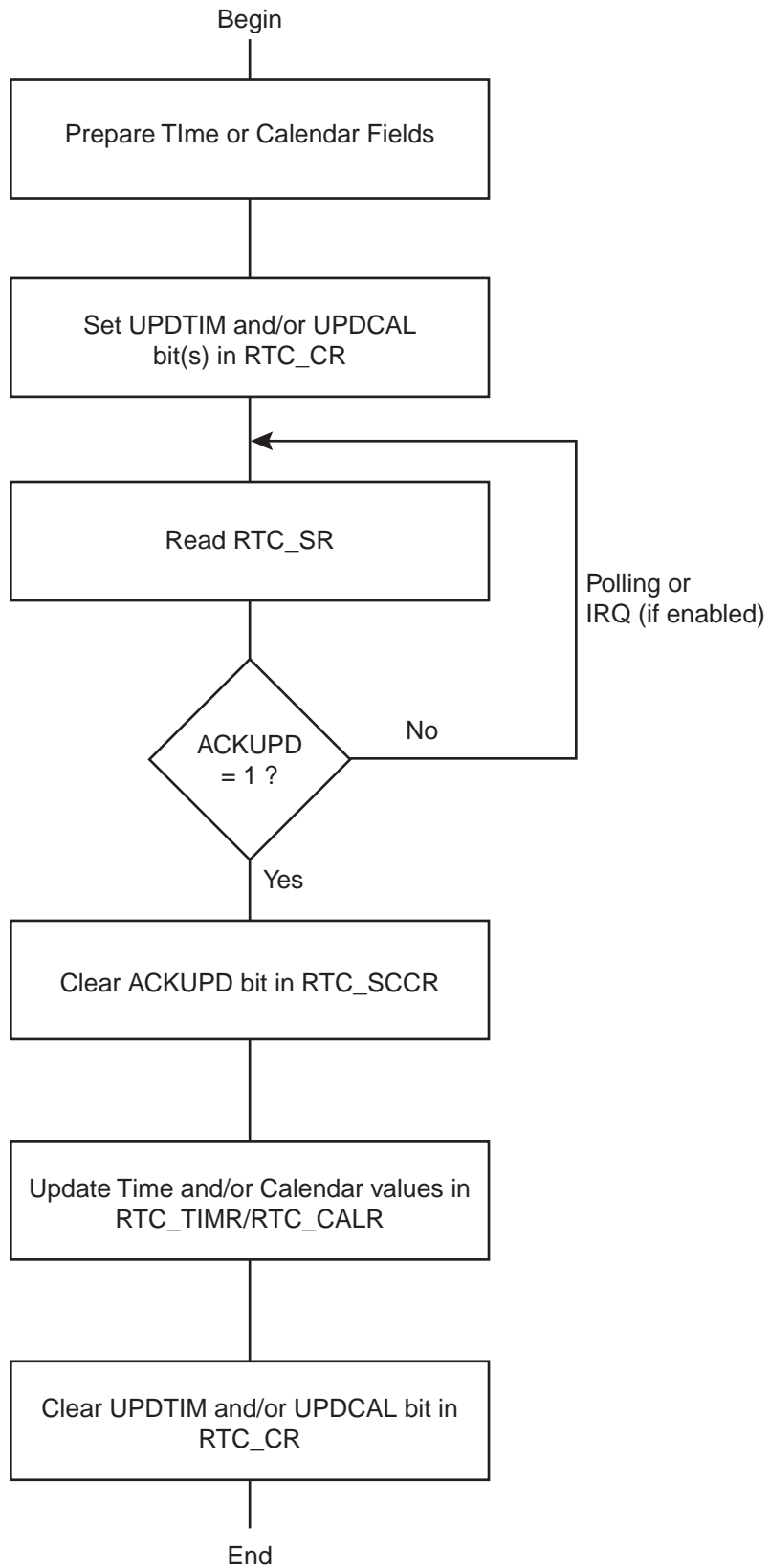

15.5.7 RTC Accurate Clock Calibration

The crystal oscillator that drives the RTC may not be as accurate as expected mainly due to temperature variation. The RTC is equipped with circuitry able to correct slow clock crystal drift.

To compensate for possible temperature variations over time, this accurate clock calibration circuitry can be programmed on-the-fly and also programmed during application manufacturing, in order to correct the crystal frequency accuracy at room temperature (20-25°C). The typical clock drift range at room temperature is ± 20 ppm.

In a temperature range of -40°C to +85°C, the 32.768 KHz crystal oscillator clock inaccuracy can be up to -200 ppm.

The RTC clock calibration circuitry allows positive or negative correction in a range of 1.5 ppm to 1950 ppm. After correction, the remaining crystal drift is as follows:

- Below 1 ppm, for an initial crystal drift between 1.5 ppm up to 90 ppm
- Below 2 ppm, for an initial crystal drift between 90 ppm up to 130 ppm
- Below 5 ppm, for an initial crystal drift between 130 ppm up to 200 ppm

The calibration circuitry acts by slightly modifying the 1 Hz clock period from time to time. When the period is modified, depending on the sign of the correction, the 1 Hz clock period increases or reduces by around 4 ms. The period interval between 2 correction events is programmable in order to cover the possible crystal oscillator clock variations.

The inaccuracy of a crystal oscillator at typical room temperature (± 20 ppm at 20-25 degrees Celsius) can be compensated if a reference clock/signal is used to measure such inaccuracy. This kind of calibration operation can be set up during the final product manufacturing by means of measurement equipment embedding such a reference clock. The correction of value must be programmed into the RTC Mode Register (RTC_MR), and this value is kept as long as the circuitry is powered (backup area). Removing the backup power supply cancels this calibration. This room temperature calibration can be further processed by means of the networking capability of the target application.

To ease the comparison of the inherent crystal accuracy with the reference clock/signal during manufacturing, an internal prescaled 32.768KHz clock derivative signal can be assigned to drive RTC output. To accommodate the measure, several clock frequencies can be selected among 1 Hz, 32 Hz, 64 Hz, 512 Hz.

In any event, this adjustment does not take into account the temperature variation.

The frequency drift (up to -200 ppm) due to temperature variation can be compensated using a reference time if the application can access such a reference. If a reference time cannot be used, a temperature sensor can be placed close to the crystal oscillator in order to get the operating temperature of the crystal oscillator. Once obtained, the temperature may be converted using a lookup table (describing the accuracy/temperature curve of the crystal oscillator used) and RTC_MR configured accordingly. The calibration can be performed on-the-fly. This adjustment method is not based on a measurement of the crystal frequency/drift and therefore can be improved by means of the networking capability of the target application.

If no crystal frequency adjustment has been done during manufacturing, it is still possible to do it. In the case where a reference time of the day can be obtained through LAN/WAN network, it is possible to calculate the drift of the application crystal oscillator by comparing the values read on RTC Time Register (RTC_TIMR) and programming the HIGHPPM and CORRECTION bit-fields on RTC_MR according to the difference measured between the reference time and those of RTC_TIMR.

15.5.8 Waveform Generation

Waveforms can be generated by the RTC in order to take advantage of the RTC inherent prescalers while the RTC is the only powered circuitry (low power mode of operation, backup mode) or in any active modes. Going into backup or low power operating modes does not affect the waveform generation outputs.

The RTC outputs (RTCOU0 and RTCOU1) can have a source driver selected among 7 possibilities.

The first selection choice sticks the associated output at 0. (This is the reset value and it can be used at any time to disable the waveform generation.)

Selection choices 1 to 4 respectively select 1Hz, 32Hz, 64Hz and 512Hz.

32Hz or 64Hz can drive, for example, a TN LCD backplane signal while 1Hz can be used to drive a blinking character like “.” for basic time display (hour, minute) on TN LCDs.

Selection choice 5 provides a toggling signal when the RTC alarm is reached.

Selection choice 6 provides a copy of the alarm flag, so the associated output is set high (logical 1) when an alarm occurs and immediately cleared when software clears the alarm interrupt source.

Selection choice 7 provides a 1Hz periodic high pulse of 15 μ s duration that can be used to drive external devices for power consumption reduction or any other purpose.

PIO lines associated to RTC outputs are automatically selecting these waveforms as soon as RTC_MR register corresponding fields OUT0 and OUT1 differ from 0.

Figure 15-3. Waveform Generation

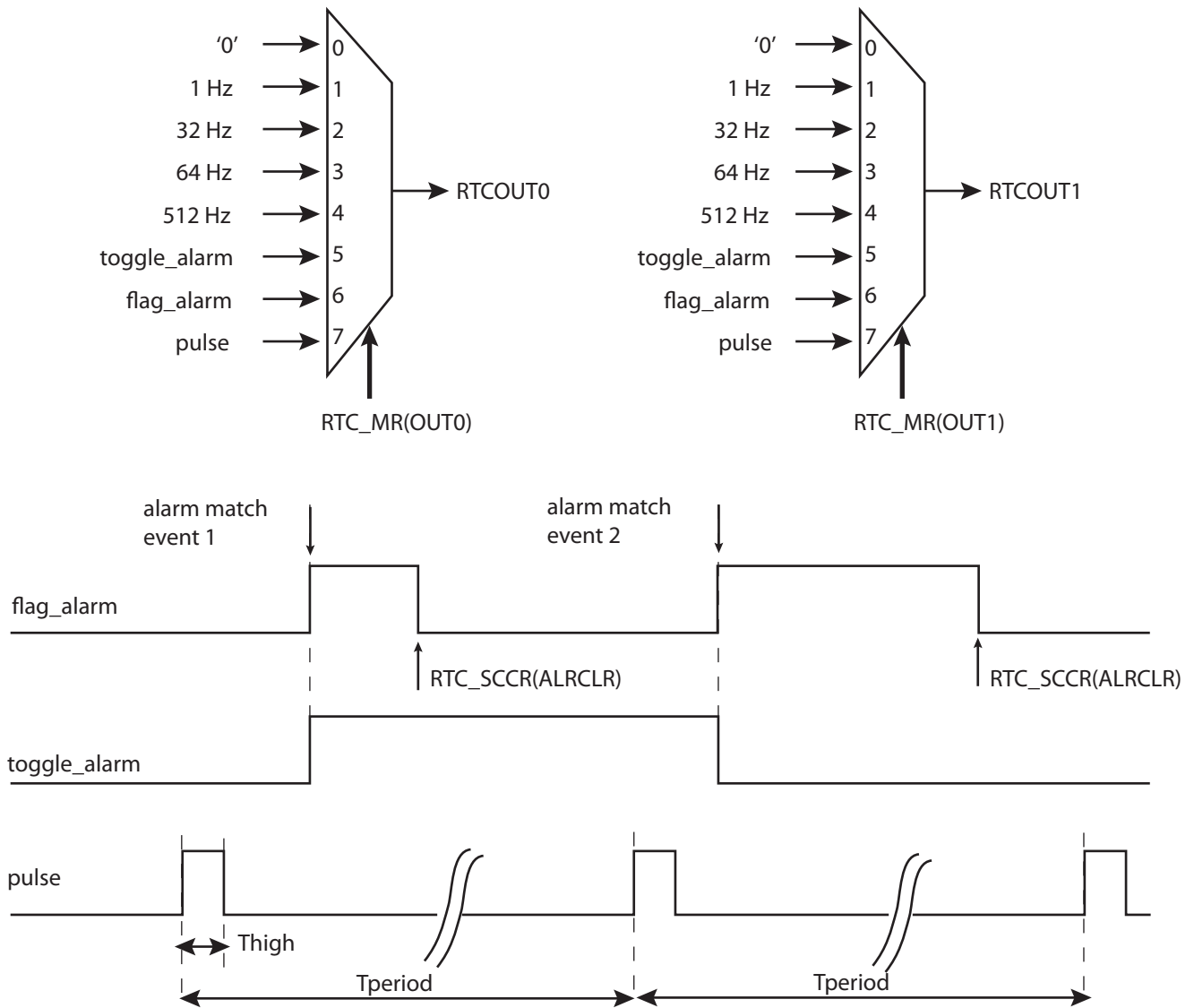

15.6 Real-Time Clock (RTC) User Interface

Table 15-1. Register Mapping

Offset	Register	Name	Access	Reset
0x00	Control Register	RTC_CR	Read-write	0x0
0x04	Mode Register	RTC_MR	Read-write	0x0
0x08	Time Register	RTC_TIMR	Read-write	0x0
0x0C	Calendar Register	RTC_CALR	Read-write	0x01A11020
0x10	Time Alarm Register	RTC_TIMALR	Read-write	0x0
0x14	Calendar Alarm Register	RTC_CALALR	Read-write	0x01010000
0x18	Status Register	RTC_SR	Read-only	0x0
0x1C	Status Clear Command Register	RTC_SCCR	Write-only	–
0x20	Interrupt Enable Register	RTC_IER	Write-only	–
0x24	Interrupt Disable Register	RTC_IDR	Write-only	–
0x28	Interrupt Mask Register	RTC_IMR	Read-only	0x0
0x2C	Valid Entry Register	RTC_VER	Read-only	0x0
0x30–0xC4	Reserved Register	–	–	–
0xC8–0xF8	Reserved Register	–	–	–
0xFC	Reserved Register	–	–	–

Note: If an offset is not listed in the table it must be considered as reserved.

15.6.1 RTC Control Register

Name: RTC_CR

Address: 0x400E1460

Access: Read-write

31	30	29	28	27	26	25	24
–	–	–	–	–	–	–	–
23	22	21	20	19	18	17	16
–	–	–	–	–	–	CALEVSEL	
15	14	13	12	11	10	9	8
–	–	–	–	–	–	TIMEVSEL	
7	6	5	4	3	2	1	0
–	–	–	–	–	–	UPDCAL	UPDTIM

- **UPDTIM: Update Request Time Register**

0 = No effect.

1 = Stops the RTC time counting.

Time counting consists of second, minute and hour counters. Time counters can be programmed once this bit is set and acknowledged by the bit ACKUPD of the Status Register.

- **UPDCAL: Update Request Calendar Register**

0 = No effect.

1 = Stops the RTC calendar counting.

Calendar counting consists of day, date, month, year and century counters. Calendar counters can be programmed once this bit is set.

- **TIMEVSEL: Time Event Selection**

The event that generates the flag TIMEV in RTC_SR (Status Register) depends on the value of TIMEVSEL.

Value	Name	Description
0	MINUTE	Minute change
1	HOUR	Hour change
2	MIDNIGHT	Every day at midnight
3	NOON	Every day at noon

- **CALEVSEL: Calendar Event Selection**

The event that generates the flag CALEV in RTC_SR depends on the value of CALEVSEL

Value	Name	Description
0	WEEK	Week change (every Monday at time 00:00:00)
1	MONTH	Month change (every 01 of each month at time 00:00:00)
2	YEAR	Year change (every January 1 at time 00:00:00)
3	–	

15.6.2 RTC Mode Register

Name: RTC_MR
Address: 0x400E1464
Access: Read-write

31	30	29	28	27	26	25	24
–	–	TPERIOD		–	THIGH		
23	22	21	20	19	18	17	16
–	OUT1			–	OUT0		
15	14	13	12	11	10	9	8
HIGHPPM		CORRECTION					
7	6	5	4	3	2	1	0
–	–	–	NEGPPM	–	–	PERSIAN	HRMOD

- **HRMOD: 12-/24-hour Mode**

0 = 24-hour mode is selected.

1 = 12-hour mode is selected.

- **PERSIAN: PERSIAN Calendar**

0 = Gregorian Calendar.

1 = Persian Calendar.

- **NEGPPM: NEGative PPM Correction**

0 = positive correction (the divider will be slightly lower than 32768).

1 = negative correction (the divider will be slightly higher than 32768).

Refer to CORRECTION and HIGHPPM field descriptions.

- **CORRECTION:**

0 = No correction

1..127 = The slow clock will be corrected according to the formula given below in HIGHPPM description.

- **HIGHPPM: HIGH PPM Correction**

0 = lower range ppm correction with accurate correction.

1 = higher range ppm correction with accurate correction.

If the absolute value of the correction to be applied is lower than 30ppm, it is recommended to clear HIGHPPM. HIGHPPM set to 1 is recommended for 30 ppm correction and above.

Formula:

If HIGHPPM = 0, then the clock frequency correction range is from 1.5 ppm up to 98 ppm. The RTC accuracy is less than 1 ppm for a range correction from 1.5 ppm up to 30 ppm..

The correction field must be programmed according to the required correction in ppm, the formula is as follows:

$$CORRECTION = \frac{3906}{20 \times ppm} - 1$$

The value obtained must be rounded to the nearest integer prior to being programmed into CORRECTION field.

If HIGHPPM = 1, then the clock frequency correction range is from 30.5 ppm up to 1950 ppm. The RTC accuracy is less than 1 ppm for a range correction from 30.5 ppm up to 90 ppm.

The correction field must be programmed according to the required correction in ppm, the formula is as follows:

$$CORRECTION = \frac{3906}{ppm} - 1$$

The value obtained must be rounded to the nearest integer prior to be programmed into CORRECTION field.

If NEGPPM is set to 1, the ppm correction is negative.

- **OUT0: RTCOUT0 Output Source Selection**

Value	Name	Description
0	NO_WAVE	no waveform, stuck at '0'
1	FREQ1HZ	1 Hz square wave
2	FREQ32HZ	32 Hz square wave
3	FREQ64HZ	64 Hz square wave
4	FREQ512HZ	512 Hz square wave
5	ALARM_TOGGLE	output toggles when alarm flag rises
6	ALARM_FLAG	output is a copy of the alarm flag
7	PROG_PULSE	duty cycle programmable pulse

- **OUT1: RTCOUT1 Output Source Selection**

Value	Name	Description
0	NO_WAVE	no waveform, stuck at '0'
1	FREQ1HZ	1 Hz square wave
2	FREQ32HZ	32 Hz square wave
3	FREQ64HZ	64 Hz square wave
4	FREQ512HZ	512 Hz square wave
5	ALARM_TOGGLE	output toggles when alarm flag rises
6	ALARM_FLAG	output is a copy of the alarm flag
7	PROG_PULSE	duty cycle programmable pulse

- **THIGH: High Duration of the Output Pulse**

Value	Name	Description
0	H_31MS	31.2 ms
1	H_16MS	15.6 ms
2	H_4MS	3.91 ms
3	H_976US	976 μ s
4	H_488US	488 μ s
5	H_122US	122 μ s
6	H_30US	30.5 μ s
7	H_15US	15.2 μ s

- **TPERIOD: Period of the Output Pulse**

Value	Name	Description
0	P_1S	1 second
1	P_500MS	500 ms
2	P_250MS	250 ms
3	P_125MS	125 ms

15.6.3 RTC Time Register

Name: RTC_TIMR
Address: 0x400E1468
Access: Read-write

31	30	29	28	27	26	25	24
–	–	–	–	–	–	–	–
23	22	21	20	19	18	17	16
–	AMPM	HOUR					
15	14	13	12	11	10	9	8
–	MIN						
7	6	5	4	3	2	1	0
–	SEC						

- **SEC: Current Second**

The range that can be set is 0 - 59 (BCD).

The lowest four bits encode the units. The higher bits encode the tens.

- **MIN: Current Minute**

The range that can be set is 0 - 59 (BCD).

The lowest four bits encode the units. The higher bits encode the tens.

- **HOUR: Current Hour**

The range that can be set is 1 - 12 (BCD) in 12-hour mode or 0 - 23 (BCD) in 24-hour mode.

- **AMPM: Ante Meridiem Post Meridiem Indicator**

This bit is the AM/PM indicator in 12-hour mode.

0 = AM.

1 = PM.

All non-significant bits read zero.

15.6.4 RTC Calendar Register

Name: RTC_CALR
Address: 0x400E146C
Access: Read-write

31	30	29	28	27	26	25	24
-		-		DATE			
23	22	21	20	19	18	17	16
DAY				MONTH			
15	14	13	12	11	10	9	8
YEAR							
7	6	5	4	3	2	1	0
-		CENT					

- CENT: Current Century**
 The range that can be set is 19 - 20 (BCD).
 The lowest four bits encode the units. The higher bits encode the tens.
- YEAR: Current Year**
 The range that can be set is 00 - 99 (BCD).
 The lowest four bits encode the units. The higher bits encode the tens.
- MONTH: Current Month**
 The range that can be set is 01 - 12 (BCD).
 The lowest four bits encode the units. The higher bits encode the tens.
- DAY: Current Day in Current Week**
 The range that can be set is 1 - 7 (BCD).
 The coding of the number (which number represents which day) is user-defined as it has no effect on the date counter.
- DATE: Current Day in Current Month**
 The range that can be set is 01 - 31 (BCD).
 The lowest four bits encode the units. The higher bits encode the tens.

All non-significant bits read zero.

15.6.5 RTC Time Alarm Register

Name: RTC_TIMALR

Address: 0x400E1470

Access: Read-write

31	30	29	28	27	26	25	24
–	–	–	–	–	–	–	–
23	22	21	20	19	18	17	16
HOUREN	AMPM	HOUR					
15	14	13	12	11	10	9	8
MINEN	MIN						
7	6	5	4	3	2	1	0
SECEN	SEC						

- **SEC: Second Alarm**

This field is the alarm field corresponding to the BCD-coded second counter.

- **SECEN: Second Alarm Enable**

0 = The second-matching alarm is disabled.

1 = The second-matching alarm is enabled.

- **MIN: Minute Alarm**

This field is the alarm field corresponding to the BCD-coded minute counter.

- **MINEN: Minute Alarm Enable**

0 = The minute-matching alarm is disabled.

1 = The minute-matching alarm is enabled.

- **HOUR: Hour Alarm**

This field is the alarm field corresponding to the BCD-coded hour counter.

- **AMPM: AM/PM Indicator**

This field is the alarm field corresponding to the BCD-coded hour counter.

- **HOUREN: Hour Alarm Enable**

0 = The hour-matching alarm is disabled.

1 = The hour-matching alarm is enabled.



15.6.6 RTC Calendar Alarm Register

Name: RTC_CALALR
Address: 0x400E1474
Access: Read-write

31	30	29	28	27	26	25	24
DATEEN	–	DATE					
23	22	21	20	19	18	17	16
MTHEN	–	–	MONTH				
15	14	13	12	11	10	9	8
–	–	–	–	–	–	–	–
7	6	5	4	3	2	1	0
–	–	–	–	–	–	–	–

- **MONTH: Month Alarm**
This field is the alarm field corresponding to the BCD-coded month counter.
- **MTHEN: Month Alarm Enable**
0 = The month-matching alarm is disabled.
1 = The month-matching alarm is enabled.
- **DATE: Date Alarm**
This field is the alarm field corresponding to the BCD-coded date counter.
- **DATEEN: Date Alarm Enable**
0 = The date-matching alarm is disabled.
1 = The date-matching alarm is enabled.

15.6.7 RTC Status Register

Name: RTC_SR
Address: 0x400E1478
Access: Read-only

31	30	29	28	27	26	25	24
–	–	–	–	–	–	–	–
23	22	21	20	19	18	17	16
–	–	–	–	–	–	–	–
15	14	13	12	11	10	9	8
–	–	–	–	–	–	–	–
7	6	5	4	3	2	1	0
–	–	TDERR	CALEV	TIMEV	SEC	ALARM	ACKUPD

- **ACKUPD: Acknowledge for Update**

0 (FREERUN) = Time and calendar registers cannot be updated.

1 (UPDATE) = Time and calendar registers can be updated.

- **ALARM: Alarm Flag**

0 (NO_ALARM_EVENT) = No alarm matching condition occurred.

1 (ALARM_EVENT) = An alarm matching condition has occurred.

- **SEC: Second Event**

0 (NO_SECEVENT) = No second event has occurred since the last clear.

1 (SECEVENT) = At least one second event has occurred since the last clear.

- **TIMEV: Time Event**

0 (NO_TIMEEVENT) = No time event has occurred since the last clear.

1 (TIMEEVENT) = At least one time event has occurred since the last clear.

The time event is selected in the TIMEVSEL field in RTC_CR (Control Register) and can be any one of the following events: minute change, hour change, noon, midnight (day change).

- **CALEV: Calendar Event**

0 (NO_CALEVENT) = No calendar event has occurred since the last clear.

1 (CALEVENT) = At least one calendar event has occurred since the last clear.

The calendar event is selected in the CALEVSEL field in RTC_CR and can be any one of the following events: week change, month change and year change.

- **TDERR: Time and/or Date Free Running Error**

0 (CORRECT) = The internal free running counters are carrying valid values since the last read of RTC_SR.

1 (ERR_TIMEDATE) = The internal free running counters have been corrupted (invalid date or time, non-BCD values) since the last read and/or they are still invalid.

15.6.8 RTC Status Clear Command Register

Name: RTC_SCCR
Address: 0x400E147C
Access: Write-only

31	30	29	28	27	26	25	24
–	–	–	–	–	–	–	–
23	22	21	20	19	18	17	16
–	–	–	–	–	–	–	–
15	14	13	12	11	10	9	8
–	–	–	–	–	–	–	–
7	6	5	4	3	2	1	0
–	–	TDERRCLR	CALCLR	TIMCLR	SECCLR	ALRCLR	ACKCLR

- **ACKCLR: Acknowledge Clear**
 0 = No effect.
 1 = Clears corresponding status flag in the Status Register (RTC_SR).
- **ALRCLR: Alarm Clear**
 0 = No effect.
 1 = Clears corresponding status flag in the Status Register (RTC_SR).
- **SECCLR: Second Clear**
 0 = No effect.
 1 = Clears corresponding status flag in the Status Register (RTC_SR).
- **TIMCLR: Time Clear**
 0 = No effect.
 1 = Clears corresponding status flag in the Status Register (RTC_SR).
- **CALCLR: Calendar Clear**
 0 = No effect.
 1 = Clears corresponding status flag in the Status Register (RTC_SR).
- **TDERRCLR: Time and/or Date Free Running Error Clear**
 0 = No effect.
 1 = Clears corresponding status flag in the Status Register (RTC_SR).

15.6.9 RTC Interrupt Enable Register

Name: RTC_IER
Address: 0x400E1480
Access: Write-only

31	30	29	28	27	26	25	24
–	–	–	–	–	–	–	–
23	22	21	20	19	18	17	16
–	–	–	–	–	–	–	–
15	14	13	12	11	10	9	8
–	–	–	–	–	–	–	–
7	6	5	4	3	2	1	0
–	–	TDERREN	CALEN	TIMEN	SECEN	ALREN	ACKEN

- **ACKEN: Acknowledge Update Interrupt Enable**
 0 = No effect.
 1 = The acknowledge for update interrupt is enabled.

- **ALREN: Alarm Interrupt Enable**
 0 = No effect.
 1 = The alarm interrupt is enabled.

- **SECEN: Second Event Interrupt Enable**
 0 = No effect.
 1 = The second periodic interrupt is enabled.

- **TIMEN: Time Event Interrupt Enable**
 0 = No effect.
 1 = The selected time event interrupt is enabled.

- **CALEN: Calendar Event Interrupt Enable**
 0 = No effect.
 1 = The selected calendar event interrupt is enabled.

- **TDERREN: Time and/or Date Error Interrupt Enable**
 0 = No effect.
 1 = The time and date error interrupt is enabled.

15.6.10 RTC Interrupt Disable Register

Name: RTC_IDR
Address: 0x400E1484
Access: Write-only

31	30	29	28	27	26	25	24
–	–	–	–	–	–	–	–
23	22	21	20	19	18	17	16
–	–	–	–	–	–	–	–
15	14	13	12	11	10	9	8
–	–	–	–	–	–	–	–
7	6	5	4	3	2	1	0
–	–	TDERRDIS	CALDIS	TIMDIS	SECDIS	ALRDIS	ACKDIS

- **ACKDIS: Acknowledge Update Interrupt Disable**
 0 = No effect.
 1 = The acknowledge for update interrupt is disabled.
- **ALRDIS: Alarm Interrupt Disable**
 0 = No effect.
 1 = The alarm interrupt is disabled.
- **SECDIS: Second Event Interrupt Disable**
 0 = No effect.
 1 = The second periodic interrupt is disabled.
- **TIMDIS: Time Event Interrupt Disable**
 0 = No effect.
 1 = The selected time event interrupt is disabled.
- **CALDIS: Calendar Event Interrupt Disable**
 0 = No effect.
 1 = The selected calendar event interrupt is disabled.
- **TDERRDIS: Time and/or Date Error Interrupt Disable**
 0 = No effect.
 1 = The time and date error interrupt is disabled.

15.6.11 RTC Interrupt Mask Register

Name: RTC_IMR
Address: 0x400E1488
Access: Read-only

31	30	29	28	27	26	25	24
–	–	–	–	–	–	–	–
23	22	21	20	19	18	17	16
–	–	–	–	–	–	–	–
15	14	13	12	11	10	9	8
–	–	–	–	–	–	–	–
7	6	5	4	3	2	1	0
–	–	–	CAL	TIM	SEC	ALR	ACK

- ACK: Acknowledge Update Interrupt Mask**
 0 = The acknowledge for update interrupt is disabled.
 1 = The acknowledge for update interrupt is enabled.
- ALR: Alarm Interrupt Mask**
 0 = The alarm interrupt is disabled.
 1 = The alarm interrupt is enabled.
- SEC: Second Event Interrupt Mask**
 0 = The second periodic interrupt is disabled.
 1 = The second periodic interrupt is enabled.
- TIM: Time Event Interrupt Mask**
 0 = The selected time event interrupt is disabled.
 1 = The selected time event interrupt is enabled.
- CAL: Calendar Event Interrupt Mask**
 0 = The selected calendar event interrupt is disabled.
 1 = The selected calendar event interrupt is enabled.

15.6.12 RTC Valid Entry Register

Name: RTC_VER
Address: 0x400E148C
Access: Read-only

31	30	29	28	27	26	25	24
–	–	–	–	–	–	–	–
23	22	21	20	19	18	17	16
–	–	–	–	–	–	–	–
15	14	13	12	11	10	9	8
–	–	–	–	–	–	–	–
7	6	5	4	3	2	1	0
–	–	–	–	NVCALALR	NVTIMALR	NVCAL	NVTIM

- **NVTIM: Non-valid Time**

0 = No invalid data has been detected in RTC_TIMR (Time Register).
 1 = RTC_TIMR has contained invalid data since it was last programmed.

- **NVCAL: Non-valid Calendar**

0 = No invalid data has been detected in RTC_CALR (Calendar Register).
 1 = RTC_CALR has contained invalid data since it was last programmed.

- **NVTIMALR: Non-valid Time Alarm**

0 = No invalid data has been detected in RTC_TIMALR (Time Alarm Register).
 1 = RTC_TIMALR has contained invalid data since it was last programmed.

- **NVCALALR: Non-valid Calendar Alarm**

0 = No invalid data has been detected in RTC_CALALR (Calendar Alarm Register).
 1 = RTC_CALALR has contained invalid data since it was last programmed.

16. Watchdog Timer (WDT)

16.1 Description

The Watchdog Timer (WDT) can be used to prevent system lock-up if the software becomes trapped in a deadlock. It features a 12-bit down counter that allows a watchdog period of up to 16 seconds (slow clock at 32.768 kHz). It can generate a general reset or a processor reset only. In addition, it can be stopped while the processor is in debug mode or idle mode.

16.2 Embedded Characteristics

- 16-bit key-protected only-once-Programmable Counter
- Windowed, prevents the processor to be in a dead-lock on the watchdog access.

16.3 Block Diagram

Figure 16-1. Watchdog Timer Block Diagram

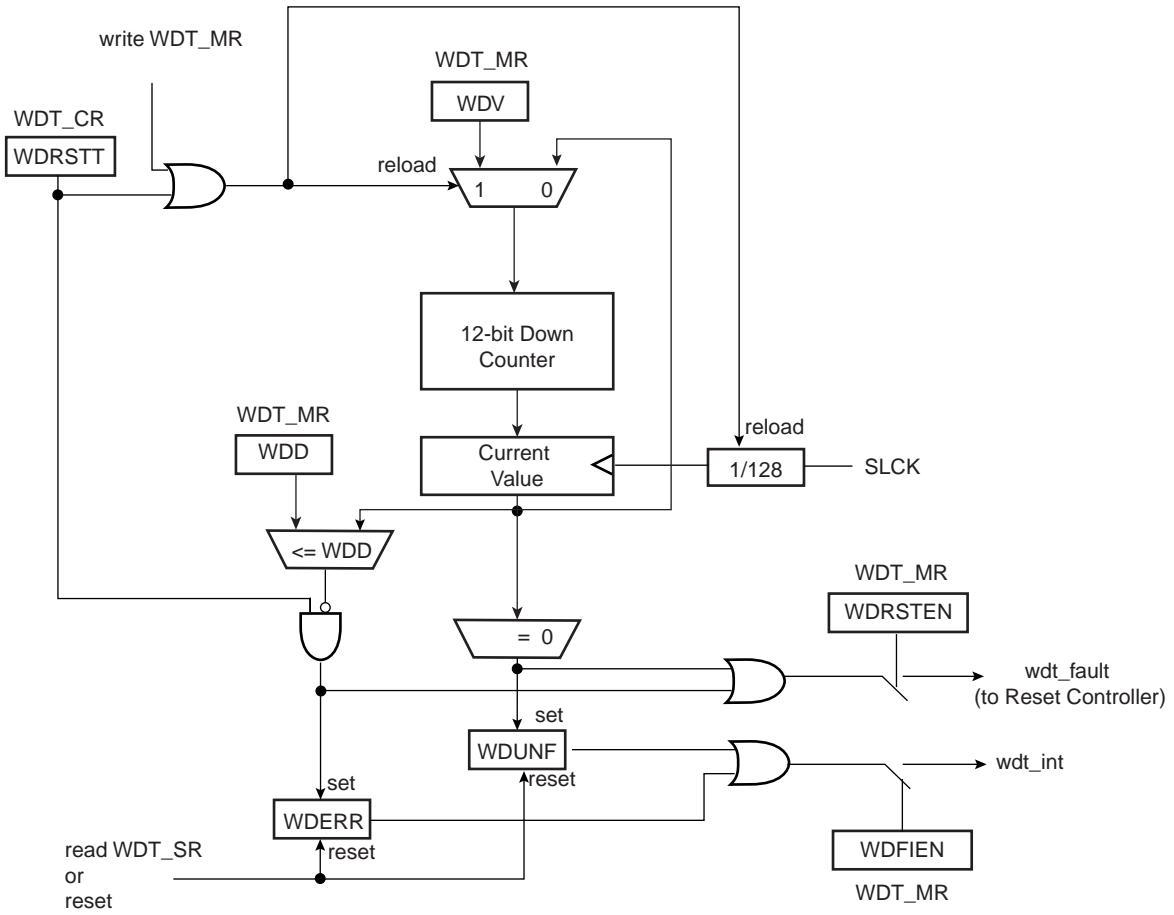

16.4 Functional Description

The Watchdog Timer can be used to prevent system lock-up if the software becomes trapped in a deadlock. It is supplied with VDDCORE. It restarts with initial values on processor reset.

The Watchdog is built around a 12-bit down counter, which is loaded with the value defined in the field WDV of the Mode Register (WDT_MR). The Watchdog Timer uses the Slow Clock divided by 128 to establish the maximum Watchdog period to be 16 seconds (with a typical Slow Clock of 32.768 kHz).

After a Processor Reset, the value of WDV is 0xFFFF, corresponding to the maximum value of the counter with the external reset generation enabled (field WDRSTEN at 1 after a Backup Reset). This means that a default Watchdog is running at reset, i.e., at power-up. The user must either disable it (by setting the WDDIS bit in WDT_MR) if he does not expect to use it or must reprogram it to meet the maximum Watchdog period the application requires.

The Watchdog Mode Register (WDT_MR) can be written only once. Only a processor reset resets it. Writing the WDT_MR register reloads the timer with the newly programmed mode parameters.

In normal operation, the user reloads the Watchdog at regular intervals before the timer underflow occurs, by writing the Control Register (WDT_CR) with the bit WDRSTT to 1. The Watchdog counter is then immediately reloaded from WDT_MR and restarted, and the Slow Clock 128 divider is reset and restarted. The WDT_CR register is write-protected. As a result, writing WDT_CR without the correct hard-coded key has no effect. If an underflow does occur, the “wdt_fault” signal to the Reset Controller is asserted if the bit WDRSTEN is set in the Mode Register (WDT_MR). Moreover, the bit WDUNF is set in the Watchdog Status Register (WDT_SR).

To prevent a software deadlock that continuously triggers the Watchdog, the reload of the Watchdog must occur while the Watchdog counter is within a window between 0 and WDD, WDD is defined in the WatchDog Mode Register WDT_MR.

Any attempt to restart the Watchdog while the Watchdog counter is between WDV and WDD results in a Watchdog error, even if the Watchdog is disabled. The bit WDERR is updated in the WDT_SR and the “wdt_fault” signal to the Reset Controller is asserted.

Note that this feature can be disabled by programming a WDD value greater than or equal to the WDV value. In such a configuration, restarting the Watchdog Timer is permitted in the whole range [0; WDV] and does not generate an error. This is the default configuration on reset (the WDD and WDV values are equal).

The status bits WDUNF (Watchdog Underflow) and WDERR (Watchdog Error) trigger an interrupt, provided the bit WDFIEN is set in the mode register. The signal “wdt_fault” to the reset controller causes a Watchdog reset if the WDRSTEN bit is set as already explained in the reset controller programmer Datasheet. In that case, the processor and the Watchdog Timer are reset, and the WDERR and WDUNF flags are reset.

If a reset is generated or if WDT_SR is read, the status bits are reset, the interrupt is cleared, and the “wdt_fault” signal to the reset controller is deasserted.

Writing the WDT_MR reloads and restarts the down counter.

While the processor is in debug state or in idle mode, the counter may be stopped depending on the value programmed for the bits WDIDLEHLT and WDDBGHLT in the WDT_MR.

Figure 16-2. Watchdog Behavior

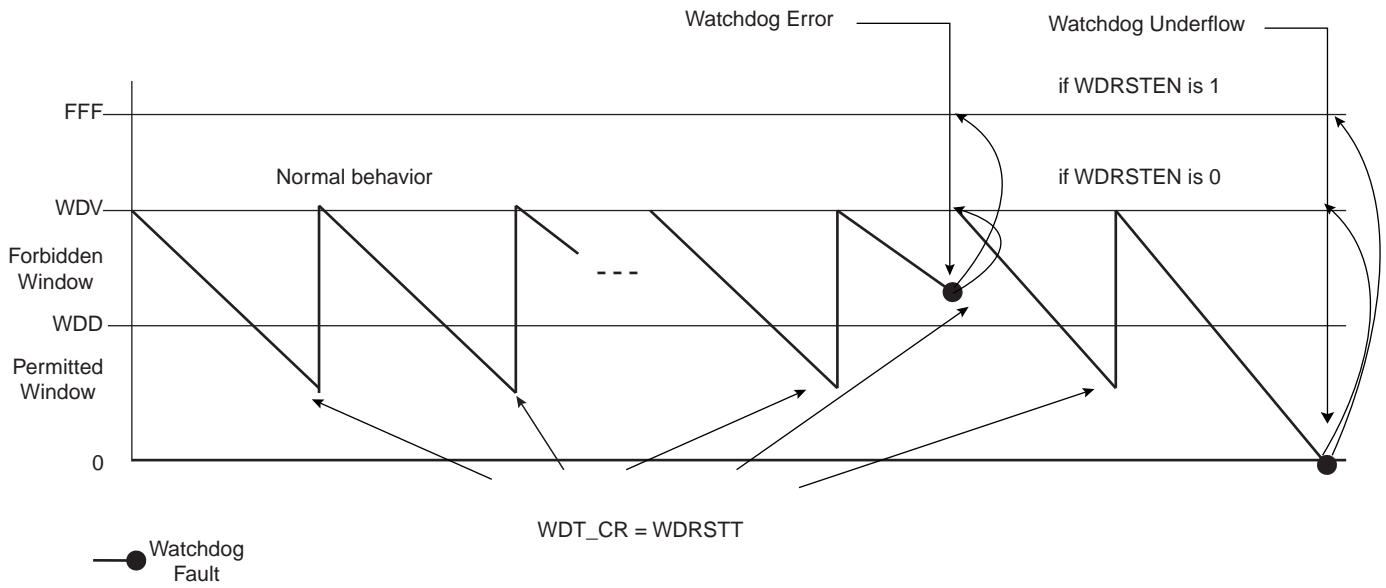

16.5 Watchdog Timer (WDT) User Interface

Table 16-1. Register Mapping

Offset	Register	Name	Access	Reset
0x00	Control Register	WDT_CR	Write-only	-
0x04	Mode Register	WDT_MR	Read-write Once	0x3FFF_2FFF
0x08	Status Register	WDT_SR	Read-only	0x0000_0000

16.5.1 Watchdog Timer Control Register

Name: WDT_CR
Address: 0x400E1450
Access: Write-only

31	30	29	28	27	26	25	24
KEY							
23	22	21	20	19	18	17	16
-	-	-	-	-	-	-	-
15	14	13	12	11	10	9	8
-	-	-	-	-	-	-	-
7	6	5	4	3	2	1	0
-	-	-	-	-	-	-	WDRSTT

- **WDRSTT: Watchdog Restart**

0: No effect.

1: Restarts the Watchdog.

- **KEY: Password**

Should be written at value 0xA5. Writing any other value in this field aborts the write operation.

16.5.2 Watchdog Timer Mode Register

Name: WDT_MR

Address: 0x400E1454

Access: Read-write Once

31	30	29	28	27	26	25	24
		WDIDLEHLT	WDDBGHLT	WDD			
23	22	21	20	19	18	17	16
WDD							
15	14	13	12	11	10	9	8
WDDIS	WDRPROC	WDRSTEN	WDFIEN	WDV			
7	6	5	4	3	2	1	0
WDV							

- **WDV: Watchdog Counter Value**

Defines the value loaded in the 12-bit Watchdog Counter.

- **WDFIEN: Watchdog Fault Interrupt Enable**

0: A Watchdog fault (underflow or error) has no effect on interrupt.

1: A Watchdog fault (underflow or error) asserts interrupt.

- **WDRSTEN: Watchdog Reset Enable**

0: A Watchdog fault (underflow or error) has no effect on the resets.

1: A Watchdog fault (underflow or error) triggers a Watchdog reset.

- **WDRPROC: Watchdog Reset Processor**

0: If WDRSTEN is 1, a Watchdog fault (underflow or error) activates all resets.

1: If WDRSTEN is 1, a Watchdog fault (underflow or error) activates the processor reset.

- **WDD: Watchdog Delta Value**

Defines the permitted range for reloading the Watchdog Timer.

If the Watchdog Timer value is less than or equal to WDD, writing WDT_CR with WDRSTT = 1 restarts the timer.

If the Watchdog Timer value is greater than WDD, writing WDT_CR with WDRSTT = 1 causes a Watchdog error.

- **WDDBGHLT: Watchdog Debug Halt**

0: The Watchdog runs when the processor is in debug state.

1: The Watchdog stops when the processor is in debug state.

- **WDIDLEHLT: Watchdog Idle Halt**

0: The Watchdog runs when the system is in idle mode.

1: The Watchdog stops when the system is in idle state.

- **WDDIS: Watchdog Disable**

0: Enables the Watchdog Timer.

1: Disables the Watchdog Timer.

16.5.3 Watchdog Timer Status Register

Name: WDT_SR

Address: 0x400E1458

Access: Read-only

31	30	29	28	27	26	25	24
–	–	–	–	–	–	–	–
23	22	21	20	19	18	17	16
–	–	–	–	–	–	–	–
15	14	13	12	11	10	9	8
–	–	–	–	–	–	–	–
7	6	5	4	3	2	1	0
–	–	–	–	–	–	WDERR	WDUNF

- **WDUNF: Watchdog Underflow**

0: No Watchdog underflow occurred since the last read of WDT_SR.

1: At least one Watchdog underflow occurred since the last read of WDT_SR.

- **WDERR: Watchdog Error**

0: No Watchdog error occurred since the last read of WDT_SR.

1: At least one Watchdog error occurred since the last read of WDT_SR.

17. Supply Controller (SUPC)

17.1 Description

The Supply Controller (SUPC) controls the supply voltage of the Core of the system and manages the Backup Low Power Mode. In this mode, the current consumption is reduced to a few microamps for Backup power retention. Exit from this mode is possible on multiple wake-up sources including events on WKUP pins, or a Clock alarm. The SUPC also generates the Slow Clock by selecting either the Low Power RC oscillator or the Low Power Crystal oscillator.

17.2 Embedded Characteristics

- Manages the Core Power Supply VDDCORE and the Backup Low Power Mode by Controlling the Embedded Voltage Regulator
- Generates the Slow Clock SLCK, by Selecting Either the 22-42 kHz Low Power RC Oscillator or the 32 kHz Low Power Crystal Oscillator
- Supports Multiple Wake Up Sources, for Exit from Backup Low Power Mode
 - Force Wake Up Pin, with Programmable Debouncing
 - 16 Wake Up Inputs, with Programmable Debouncing
 - Real Time Clock Alarm
 - Real Time Timer Alarm
 - Supply Monitor Detection on VDDIO, with Programmable Scan Period and Voltage Threshold
- A Supply Monitor Detection on VDDIO or a Brownout Detection on VDDCORE can Trigger a Core Reset
- Embeds:
 - One 22 to 42 kHz Low Power RC Oscillator
 - One 32 kHz Low Power Crystal Oscillator
 - One Zero-Power Power-On Reset Cell
 - One Software Programmable Supply Monitor, on VDDIO Located in Backup Section
 - One Brownout Detector on VDDCORE Located in the Core

17.3 Block Diagram

Figure 17-1. Supply Controller Block Diagram

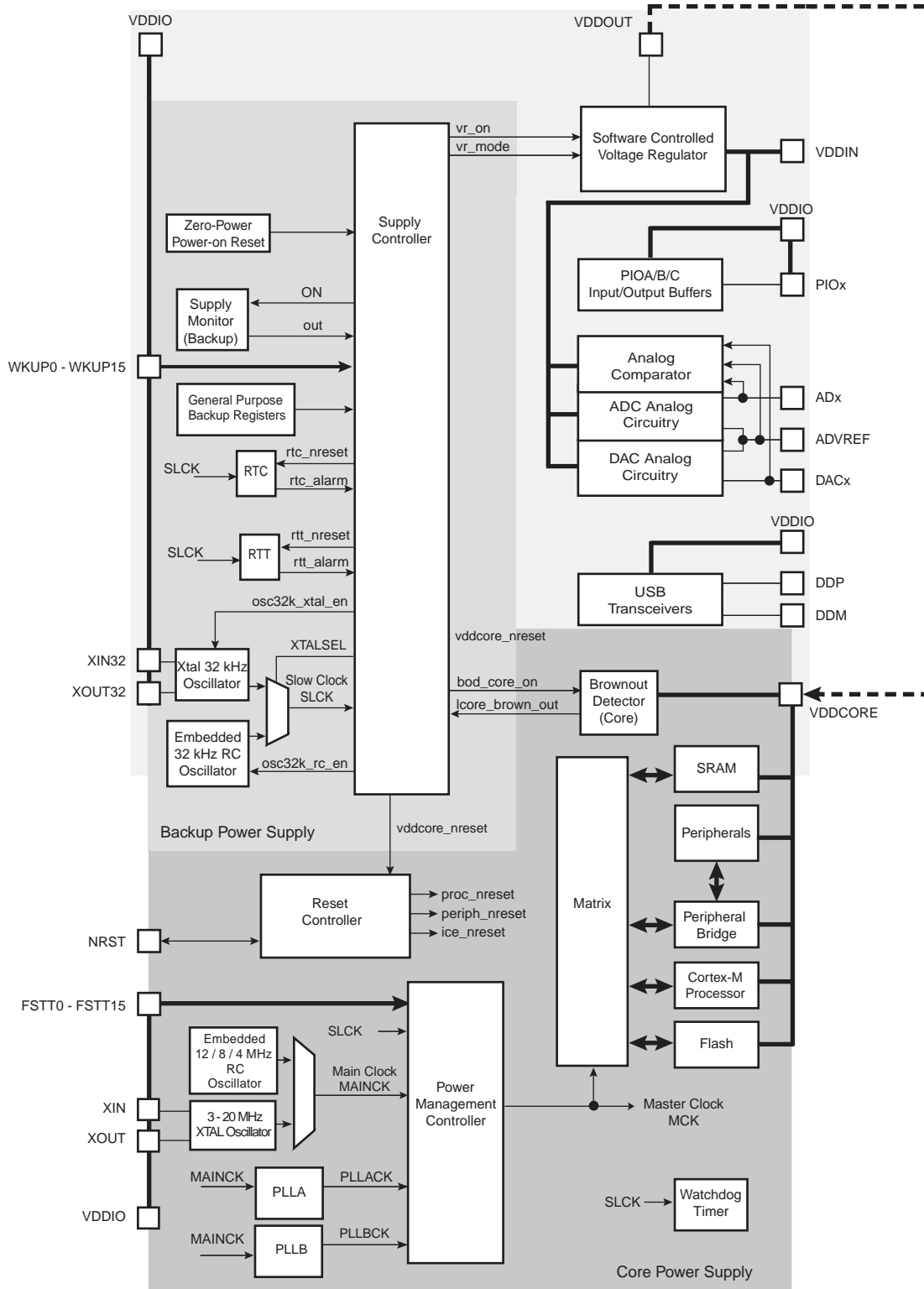

FSTT0 - FSTT15 are possible Fast Startup Sources, generated by WKUP0-WKUP15 Pins, but are not physical pins.

17.4 Supply Controller Functional Description

17.4.1 Supply Controller Overview

The device can be divided into two power supply areas:

- The VDDIO Power Supply: including the Supply Controller, a part of the Reset Controller, the Slow Clock switch, the General Purpose Backup Registers, the Supply Monitor and the Clock which includes the Real Time Timer and the Real Time Clock
- The Core Power Supply: including the other part of the Reset Controller, the Brownout Detector, the Processor, the SRAM memory, the FLASH memory and the Peripherals

The Supply Controller (SUPC) controls the supply voltage of the core power supply. The SUPC intervenes when the VDDIO power supply rises (when the system is starting) or when the Backup Low Power Mode is entered.

The SUPC also integrates the Slow Clock generator which is based on a 32 kHz crystal oscillator and an embedded 32 kHz RC oscillator. The Slow Clock defaults to the RC oscillator, but the software can enable the crystal oscillator and select it as the Slow Clock source.

The Supply Controller and the VDDIO power supply have a reset circuitry based on a zero-power power-on reset cell. The zero-power power-on reset allows the SUPC to start properly as soon as the VDDIO voltage becomes valid.

At startup of the system, once the voltage VDDIO is valid and the embedded 32 kHz RC oscillator is stabilized, the SUPC starts up the core by sequentially enabling the internal Voltage Regulator, waiting that the core voltage VDDCORE is valid, then releasing the reset signal of the core “vddcore_nreset” signal.

Once the system has started, the user can program a supply monitor and/or a brownout detector. If the supply monitor detects a voltage on VDDIO that is too low, the SUPC can assert the reset signal of the core “vddcore_nreset” signal until VDDIO is valid. Likewise, if the brownout detector detects a core voltage VDDCORE that is too low, the SUPC can assert the reset signal “vddcore_nreset” until VDDCORE is valid.

When the Backup Low Power Mode is entered, the SUPC sequentially asserts the reset signal of the core power supply “vddcore_nreset” and disables the voltage regulator, in order to supply only the VDDIO power supply. In this mode the current consumption is reduced to a few microamps for Backup part retention. Exit from this mode is possible on multiple wake-up sources including an event on WKUP pins, or a Clock alarm. To exit this mode, the SUPC operates in the same way as system startup.

17.4.2 Slow Clock Generator

The Supply Controller embeds a slow clock generator that is supplied with the VDDIO power supply. As soon as the VDDIO is supplied, both the crystal oscillator and the embedded RC oscillator are powered up, but only the embedded RC oscillator is enabled. This allows the slow clock to be valid in a short time (about 100 μ s).

The user can select the crystal oscillator to be the source of the slow clock, as it provides a more accurate frequency. The command is made by writing the Supply Controller Control Register (SUPC_CR) with the XTALSEL bit at 1. This results in a sequence which first configures the PIO lines multiplexed with XIN32 and XOUT32 to be driven by the oscillator, then enables the crystal oscillator, then counts a number of slow RC oscillator clock periods to cover the startup time of the crystal oscillator (refer to electrical characteristics for details of 32KHz crystal oscillator startup time), then switches the slow clock on the output of the crystal oscillator and then disables the RC oscillator to save power. The switching time may vary according to the slow RC oscillator clock frequency range. The switch of the slow clock source is glitch free. The OSCSEL bit of the Supply Controller Status Register (SUPC_SR) allows knowing when the switch sequence is done.

Coming back on the RC oscillator is only possible by shutting down the VDDIO power supply.

If the user does not need the crystal oscillator, the XIN32 and XOUT32 pins should be left unconnected.

The user can also set the crystal oscillator in bypass mode instead of connecting a crystal. In this case, the user has to provide the external clock signal on XIN32. The input characteristics of the XIN32 pin are given in the product electrical characteristics section. In order to set the bypass mode, the OSCBYPASS bit of the Supply Controller Mode Register (SUPC_MR) needs to be set at 1.

17.4.3 Voltage Regulator Control/Backup Low Power Mode

The Supply Controller can be used to control the embedded 1.8V voltage regulator.

The voltage regulator automatically adapts its quiescent current depending on the required load current. Please refer to the electrical characteristics section.

The programmer can switch off the voltage regulator, and thus put the device in Backup mode, by writing the Supply Controller Control Register (SUPC_CR) with the VROFF bit at 1.

This can be done also by using WFE (Wait for Event) Cortex-M processor instruction with the deep mode bit set to 1.

The Backup mode can also be entered by executing the WFI (Wait for Interrupt) or WFE (Wait for Event) Cortex-M Processor instructions. To select the Backup mode entry mechanism, two options are available, depending on the SLEEPONEXIT bit in the Cortex-M processor System Control register:

- Sleep-now: if the SLEEPONEXIT bit is cleared, the device enters Backup mode as soon as the WFI or WFE instruction is executed.
- Sleep-on-exit: if the SLEEPONEXIT bit is set when the WFI instruction is executed, the device enters Backup mode as soon as it exits the lowest priority ISR.

This asserts the vddcore_nreset signal after the write resynchronization time which lasts, in the worse case, two slow clock cycles. Once the vddcore_nreset signal is asserted, the processor and the peripherals are stopped one slow clock cycle before the core power supply shuts off.

When the user does not use the internal voltage regulator and wants to supply VDDCORE by an external supply, it is possible to disable the voltage regulator. Note that it is different from the Backup mode. Depending on the application, disabling the voltage regulator can reduce power consumption as the voltage regulator input (VDDIN) is shared with the ADC and DAC. This is done through ONREG bit in SUPC_MR.

17.4.4 Supply Monitor

The Supply Controller embeds a supply monitor which is located in the VDDIO Power Supply and which monitors VDDIO power supply.

The supply monitor can be used to prevent the processor from falling into an unpredictable state if the Main power supply drops below a certain level.

The threshold of the supply monitor is programmable. It can be selected from 1.6V to 3.4V. This threshold is programmed in the SMTH field of the Supply Controller Supply Monitor Mode Register (SUPC_SMMR).

The supply monitor can also be enabled during one slow clock period on every one of either 32, 256 or 2048 slow clock periods, according to the choice of the user. This can be configured by programming the SMSMPL field in SUPC_SMMR.

Enabling the supply monitor for such reduced times allows to divide the typical supply monitor power consumption respectively by factors of 32, 256 or 2048, if the user does not need a continuous monitoring of the VDDIO power supply.

A supply monitor detection can either generate a reset of the core power supply or a wake up of the core power supply. Generating a core reset when a supply monitor detection occurs is enabled by writing the SMRSTEN bit to 1 in SUPC_SMMR.

Waking up the core power supply when a supply monitor detection occurs can be enabled by programming the SMEN bit to 1 in the Supply Controller Wake Up Mode Register (SUPC_WUMR).

The Supply Controller provides two status bits in the Supply Controller Status Register for the supply monitor which allows to determine whether the last wake up was due to the supply monitor:

- The SMOS bit provides real time information, which is updated at each measurement cycle or updated at each Slow Clock cycle, if the measurement is continuous.
- The SMS bit provides saved information and shows a supply monitor detection has occurred since the last read of SUPC_SR.

The SMS bit can generate an interrupt if the SMIEN bit is set to 1 in the Supply Controller Supply Monitor Mode Register (SUPC_SMMR).

Figure 17-2. Supply Monitor Status Bit and Associated Interrupt

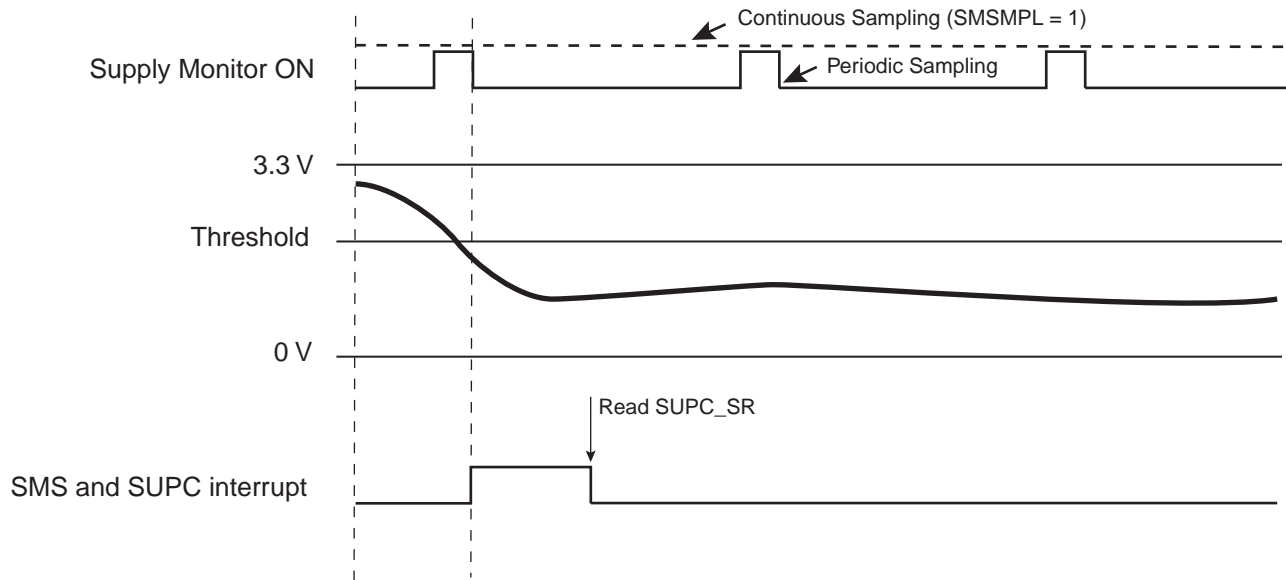

17.4.5 Power Supply Reset

17.4.5.1 Raising the Power Supply

As soon as the voltage VDDIO rises, the RC oscillator is powered up and the zero-power power-on reset cell maintains its output low as long as VDDIO has not reached its target voltage. During this time, the Supply Controller is entirely reset. When the VDDIO voltage becomes valid and zero-power power-on reset signal is released, a counter is started for 5 slow clock cycles. This is the time it takes for the 32 kHz RC oscillator to stabilize.

After this time, the voltage regulator is enabled. The core power supply rises and the brownout detector provides the bodcore_in signal as soon as the core voltage VDDCORE is valid. This results in releasing the vddcore_nreset signal to the Reset Controller after the bodcore_in signal has been confirmed as being valid for at least one slow clock cycle.

Figure 17-3. Raising the VDDIO Power Supply

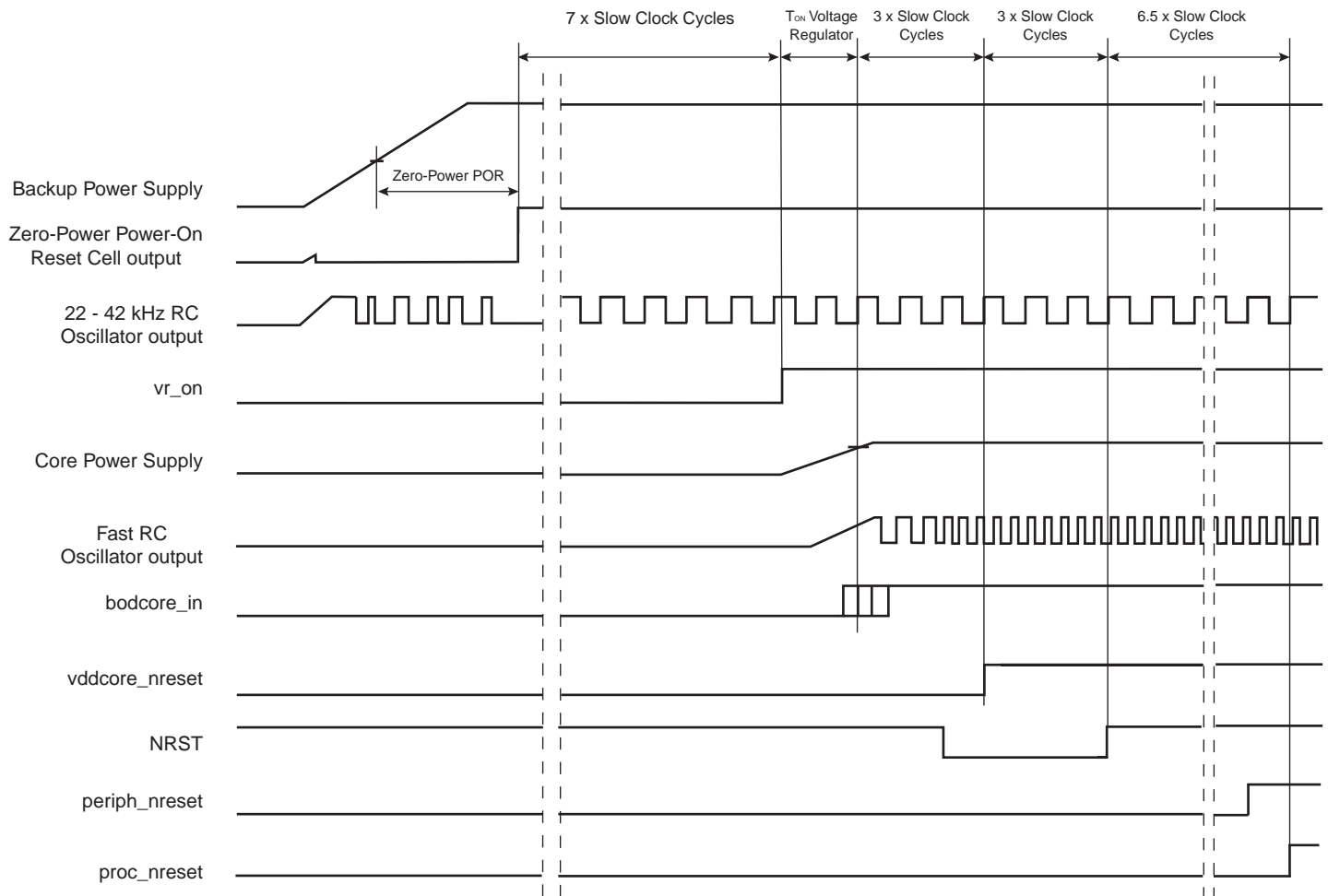

Note: After “proc_nreset” rising, the core starts fetching instructions from Flash at 4 MHz.

17.4.6 Core Reset

The Supply Controller manages the vddcore_nreset signal to the Reset Controller, as described previously in [Section 17.4.5 “Power Supply Reset”](#). The vddcore_nreset signal is normally asserted before shutting down the core power supply and released as soon as the core power supply is correctly regulated.

There are two additional sources which can be programmed to activate vddcore_nreset:

- A supply monitor detection
- A brownout detection

17.4.6.1 Supply Monitor Reset

The supply monitor is capable of generating a reset of the system. This can be enabled by setting the SMRSTEN bit in the Supply Controller Supply Monitor Mode Register (SUPC_SMMR).

If SMRSTEN is set and if a supply monitor detection occurs, the vddcore_nreset signal is immediately activated for a minimum of 1 slow clock cycle.

17.4.6.2 Brownout Detector Reset

The brownout detector provides the bodcore_in signal to the SUPC which indicates that the voltage regulation is operating as programmed. If this signal is lost for longer than 1 slow clock period while the voltage regulator is enabled, the Supply Controller can assert vddcore_nreset. This feature is enabled by writing the bit, BODRSTEN (Brownout Detector Reset Enable) to 1 in the Supply Controller Mode Register (SUPC_MR).

If BODRSTEN is set and the voltage regulation is lost (output voltage of the regulator too low), the vddcore_nreset signal is asserted for a minimum of 1 slow clock cycle and then released if bodcore_in has been reactivated. The BODRSTS bit is set in the Supply Controller Status Register (SUPC_SR) so that the user can know the source of the last reset.

Until bodcore_in is deactivated, the vddcore_nreset signal remains active.

17.4.7 Wake Up Sources

The wake up events allow the device to exit backup mode. When a wake up event is detected, the Supply Controller performs a sequence which automatically reenables the core power supply.

Figure 17-4. Wake Up Sources

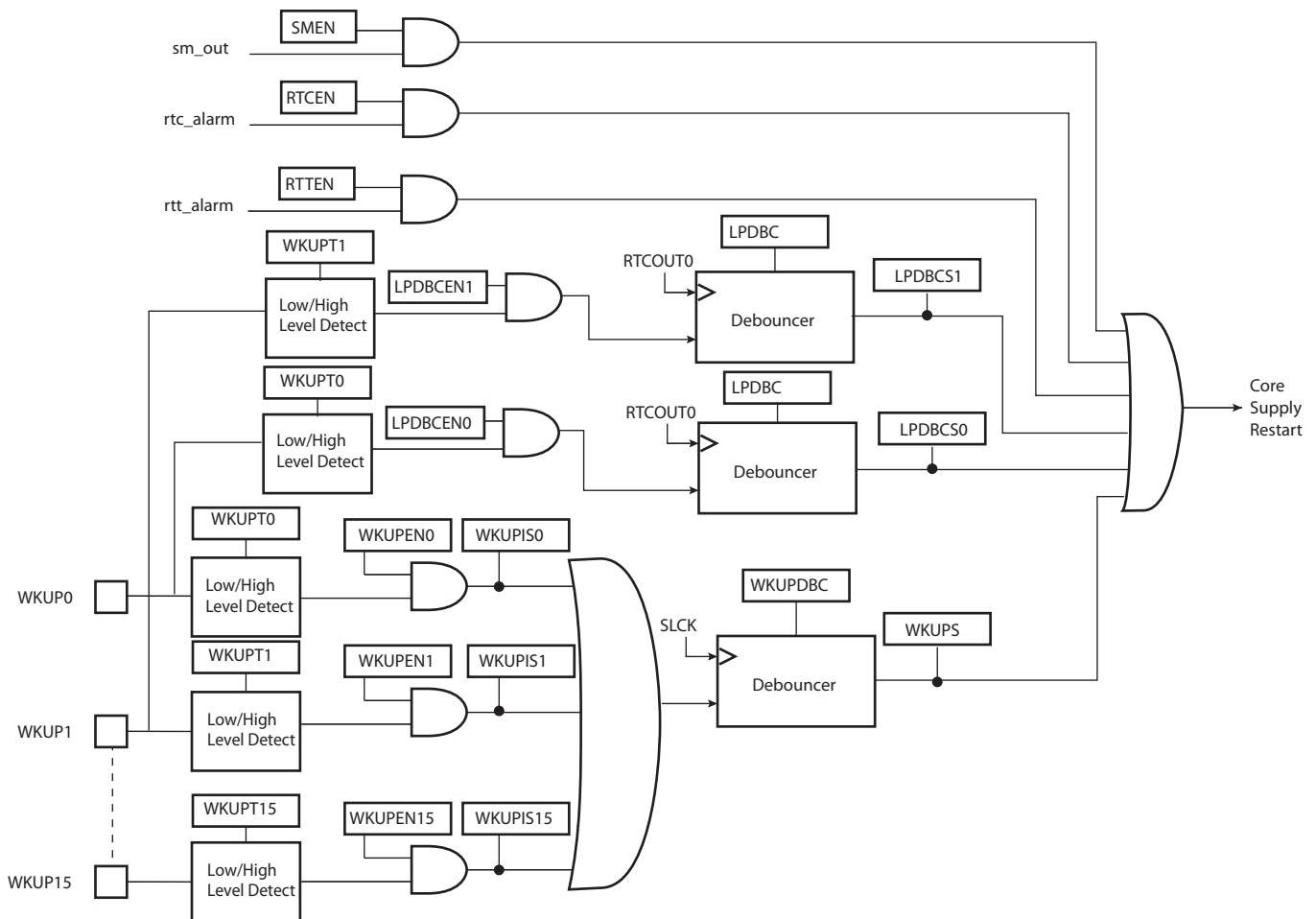

17.4.7.1 Wake Up Inputs

The wake up inputs, WKUP0 to WKUP15, can be programmed to perform a wake up of the core power supply. Each input can be enabled by writing to 1 the corresponding bit, WKUPEN0 to WKUPEN 15, in the Wake Up Inputs Register (SUPC_WUIR). The wake up level can be selected with the corresponding polarity bit, WKUPPL0 to WKUPPL15, also located in SUPC_WUIR.

All the resulting signals are wired-ORed to trigger a debounce counter, which can be programmed with the WKUPDBC field in the Supply Controller Wake Up Mode Register (SUPC_WUMR). The WKUPDBC field can select a debouncing period of 3, 32, 512, 4,096 or 32,768 slow clock cycles. This corresponds respectively to about 100 μ s, about 1 ms, about 16 ms, about 128 ms and about 1 second (for a typical slow clock frequency of 32 kHz). Programming WKUPDBC to 0x0 selects an immediate wake up, i.e., an enabled WKUP pin must be active according to its polarity during a minimum of one slow clock period to wake up the core power supply.

If an enabled WKUP pin is asserted for a time longer than the debouncing period, a wake up of the core power supply is started and the signals, WKUP0 to WKUP15 as shown in [Figure 17-4](#), are latched in the Supply Controller Status Register (SUPC_SR). This allows the user to identify the source of the wake up, however, if a new wake up condition occurs, the primary information is lost. No new wake up can be detected since the primary wake up condition has disappeared.

17.4.7.2 Low Power Debouncer Inputs

It is possible to generate a waveform (RTCOUT0 and RTCOUT1) in all modes (including backup mode). It can be useful to control an external sensor and/or tampering function without waking up the processor. Please refer to the RTC section.

Two separate debouncers are embedded for WKUP0 and WKUP1 inputs.

The WKUP0 and/or WKUP1 inputs can be programmed to perform a wake up of the core power supply with a debouncing done by RTCOUT0. This can be enabled by setting LPDBC0 bit and/or LPDBC1 bit in SUPC_WUMR.

In this mode of operation, WKUP0 and/or WKUP1 must not be configured to also act as debouncing source for the WKUPDBC counter (WKUPEN0 and/or WKUPEN1 must be cleared in SUPC_WUIR). Refer to [Figure 17-4](#).

This mode of operation requires the RTC Output (RTCOUT0) to be configured to generate a duty cycle programmable pulse (i.e. OUT0 = 0x7 in RTC_MR) in order to create the sampling points of both debouncers. The sampling point is the falling edge of the RTCOUT0 waveform.

[Figure 17-5](#) shows an example of an application where two tamper switches are used. RTCOUT0 powers the external pull-up used by the tampers.

Figure 17-5. Low Power Debouncer (Push-to-Make switch, pull-up resistors)

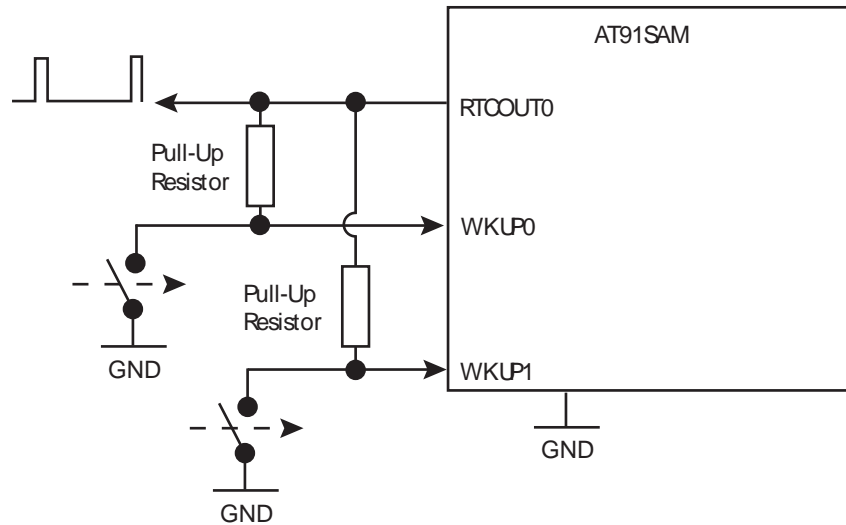
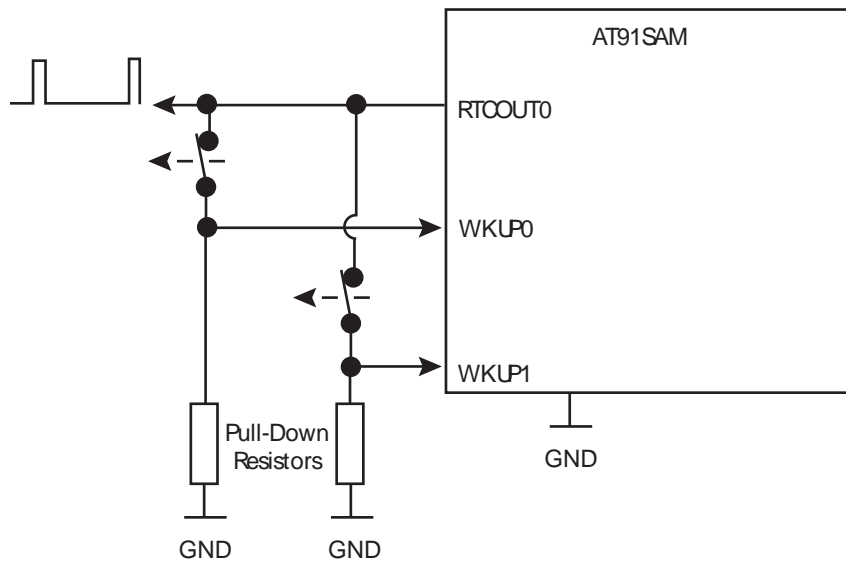

Figure 17-6. Low Power Debouncer (Push-to-Break switch, pull-down resistors)



The debouncing parameters can be adjusted and are shared (except the wake up input polarity) by both debouncers. The number of successive identical samples to wake up the core can be configured from 2 up to 8 in the LPDBC field of SUPC_WUMR. The period of time between 2 samples can be configured by programming the TPERIOD field in the RTC_MR register.

Power parameters can be adjusted by modifying the period of time in the THIGH field in RTC_MR.

The wake up polarity of the inputs can be independently configured by writing WKUPT0 and WKUPT1 fields in SUPC_WUMR.

In order to determine which wake up pin triggers the core wake up or simply which debouncer triggers an event, a status flag is associated for each low power debouncer. These 2 flags can be read in the SUPC_SR.

A debounce event can perform an immediate clear (0 delay) on first half the general purpose backup registers (GPBR). The LPDBCCLR bit must be set to 1 in SUPC_MR.

17.4.7.3 *Clock Alarms*

The RTC and the RTT alarms can generate a wake up of the core power supply. This can be enabled by writing respectively, the bits RTCEN and RTTEN to 1 in the Supply Controller Wake Up Mode Register (SUPC_WUMR).

The Supply Controller does not provide any status as the information is available in the User Interface of either the Real Time Timer or the Real Time Clock.

17.4.7.4 *Supply Monitor Detection*

The supply monitor can generate a wake-up of the core power supply. See [Section 17.4.4 "Supply Monitor"](#).

17.5 Supply Controller (SUPC) User Interface

The User Interface of the Supply Controller is a part of the System Controller User Interface.

17.5.1 System Controller (SYSC) User Interface

Table 17-1. System Controller Registers

Offset	System Controller Peripheral	Name
0x00-0x0c	Reset Controller	RSTC
0x10-0x2C	Supply Controller	SUPC
0x30-0x3C	Real Time Timer	RTT
0x50-0x5C	Watchdog Tiler	WDT
0x60-0x7C	Real Time Clock	RTC
0x90-0xDC	General Purpose Backup Register	GPBR

17.5.2 Supply Controller (SUPC) User Interface

Table 17-2. Register Mapping

Offset	Register	Name	Access	Reset
0x00	Supply Controller Control Register	SUPC_CR	Write-only	N/A
0x04	Supply Controller Supply Monitor Mode Register	SUPC_SMMR	Read-write	0x0000_0000
0x08	Supply Controller Mode Register	SUPC_MR	Read-write	0x0000_5A00
0x0C	Supply Controller Wake Up Mode Register	SUPC_WUMR	Read-write	0x0000_0000
0x10	Supply Controller Wake Up Inputs Register	SUPC_WUIR	Read-write	0x0000_0000
0x14	Supply Controller Status Register	SUPC_SR	Read-only	0x0000_0800
0x18	Reserved			

17.5.3 Supply Controller Control Register

Name: SUPC_CR

Address: 0x400E1410

Access: Write-only

31	30	29	28	27	26	25	24
KEY							
23	22	21	20	19	18	17	16
-	-	-	-	-	-	-	-
15	14	13	12	11	10	9	8
-	-	-	-	-	-	-	-
7	6	5	4	3	2	1	0
-	-	-	-	XTALSEL	VROFF	-	-

- **VROFF: Voltage Regulator Off**

0 (NO_EFFECT) = no effect.

1 (STOP_VREG) = if KEY is correct, asserts vddcore_nreset and stops the voltage regulator.

- **XTALSEL: Crystal Oscillator Select**

0 (NO_EFFECT) = no effect.

1 (CRYSTAL_SEL) = if KEY is correct, switches the slow clock on the crystal oscillator output.

- **KEY: Password**

Should be written to value 0xA5. Writing any other value in this field aborts the write operation.

17.5.4 Supply Controller Supply Monitor Mode Register

Name: SUPC_SMMR

Address: 0x400E1414

Access: Read-write

31	30	29	28	27	26	25	24
–	–	–	–	–	–	–	–
23	22	21	20	19	18	17	16
–	–	–	–	–	–	–	–
15	14	13	12	11	10	9	8
–	–	SMIEN	SMRSTEN	–	SMSMPL		
7	6	5	4	3	2	1	0
–	–	–	–	SMTH			

- **SMTH: Supply Monitor Threshold**

Please refer to Electrical chapter on [Table 42-6 "Threshold Selection"](#) (DC Characteristics).

- **SMSMPL: Supply Monitor Sampling Period**

Value	Name	Description
0x0	SMD	Supply Monitor disabled
0x1	CSM	Continuous Supply Monitor
0x2	32SLCK	Supply Monitor enabled one SLCK period every 32 SLCK periods
0x3	256SLCK	Supply Monitor enabled one SLCK period every 256 SLCK periods
0x4	2048SLCK	Supply Monitor enabled one SLCK period every 2,048 SLCK periods
0x5-0x7	Reserved	Reserved

- **SMRSTEN: Supply Monitor Reset Enable**

0 (NOT_ENABLE) = the core reset signal "vddcore_nreset" is not affected when a supply monitor detection occurs.

1 (ENABLE) = the core reset signal, vddcore_nreset is asserted when a supply monitor detection occurs.

- **SMIEN: Supply Monitor Interrupt Enable**

0 (NOT_ENABLE) = the SUPC interrupt signal is not affected when a supply monitor detection occurs.

1 (ENABLE) = the SUPC interrupt signal is asserted when a supply monitor detection occurs.

17.5.5 Supply Controller Mode Register

Name: SUPC_MR

Address: 0x400E1418

Access: Read-write

31	30	29	28	27	26	25	24
KEY							
23	22	21	20	19	18	17	16
-	-	-	OSCBYPASS	-	-	-	-
15	14	13	12	11	10	9	8
-	ONREG	BODDIS	BODRSTEN	-	-	-	-
7	6	5	4	3	2	1	0
-	-	-	-	-	-	-	-

- **BODRSTEN: Brownout Detector Reset Enable**

0 (NOT_ENABLE) = the core reset signal “vddcore_nreset” is not affected when a brownout detection occurs.

1 (ENABLE) = the core reset signal, vddcore_nreset is asserted when a brownout detection occurs.

- **BODDIS: Brownout Detector Disable**

0 (ENABLE) = the core brownout detector is enabled.

1 (DISABLE) = the core brownout detector is disabled.

- **ONREG: Voltage Regulator enable**

0 (ONREG_UNUSED) = Voltage Regulator is not used

1 (ONREG_USED) = Voltage Regulator is used

- **OSCBYPASS: Oscillator Bypass**

0 (NO_EFFECT) = no effect. Clock selection depends on XTALSEL value.

1 (BYPASS) = the 32-KHz XTAL oscillator is selected and is put in bypass mode.

- **KEY: Password Key**

Should be written to value 0xA5. Writing any other value in this field aborts the write operation.

17.5.6 Supply Controller Wake Up Mode Register

Name: SUPC_WUMR

Address: 0x400E141C

Access: Read-write

31	30	29	28	27	26	25	24
–	–	–	–	–	–	–	–
23	22	21	20	19	18	17	16
–	–	–	–	–	LPDBC		
15	14	13	12	11	10	9	8
–	WKUPDBC			–	–	–	–
7	6	5	4	3	2	1	0
LPDBCCLR	LPDBCEN1	LPDBCEN0	–	RTCEN	RTTEN	SMEN	–

- **SMEN: Supply Monitor Wake Up Enable**

0 (NOT_ENABLE) = the supply monitor detection has no wake up effect.

1 (ENABLE) = the supply monitor detection forces the wake up of the core power supply.

- **RTTEN: Real Time Timer Wake Up Enable**

0 (NOT_ENABLE) = the RTT alarm signal has no wake up effect.

1 (ENABLE) = the RTT alarm signal forces the wake up of the core power supply.

- **RTCEN: Real Time Clock Wake Up Enable**

0 (NOT_ENABLE) = the RTC alarm signal has no wake up effect.

1 (ENABLE) = the RTC alarm signal forces the wake up of the core power supply.

- **LPDBCEN0: Low power Debouncer ENable WKUP0**

0 (NOT_ENABLE) = the WKUP0 input pin is not connected with low power debouncer.

1 (ENABLE) = the WKUP0 input pin is connected with low power debouncer and can force a core wake up.

- **LPDBCEN1: Low power Debouncer ENable WKUP1**

0 (NOT_ENABLE) = the WKUP1 input pin is not connected with low power debouncer.

1 (ENABLE) = the WKUP1 input pin is connected with low power debouncer and can force a core wake up.

- **LPDBCCLR: Low power Debouncer Clear**

0 (NOT_ENABLE) = a low power debounce event does not create an immediate clear on first half GPBR registers.

1 (ENABLE) = a low power debounce event on WKUP0 or WKUP1 generates an immediate clear on first half GPBR registers.

- **WKUPDBC: Wake Up Inputs Debouncer Period**

Value	Name	Description
0	IMMEDIATE	Immediate, no debouncing, detected active at least on one Slow Clock edge.
1	3_SCLK	WKUPx shall be in its active state for at least 3 SCLK periods
2	32_SCLK	WKUPx shall be in its active state for at least 32 SCLK periods
3	512_SCLK	WKUPx shall be in its active state for at least 512 SCLK periods
4	4096_SCLK	WKUPx shall be in its active state for at least 4,096 SCLK periods
5	32768_SCLK	WKUPx shall be in its active state for at least 32,768 SCLK periods
6	Reserved	Reserved
7	Reserved	Reserved

- **LPDBC: Low Power DeBouncer Period**

Value	Name	Description
0	DISABLE	Disable the low power debouncer.
1	2_RTCOUT0	WKUP0/1 in its active state for at least 2 RTCOUT0 periods
2	3_RTCOUT0	WKUP0/1 in its active state for at least 3 RTCOUT0 periods
3	4_RTCOUT0	WKUP0/1 in its active state for at least 4 RTCOUT0 periods
4	5_RTCOUT0	WKUP0/1 in its active state for at least 5 RTCOUT0 periods
5	6_RTCOUT0	WKUP0/1 in its active state for at least 6 RTCOUT0 periods
6	7_RTCOUT0	WKUP0/1 in its active state for at least 7 RTCOUT0 periods
7	8_RTCOUT0	WKUP0/1 in its active state for at least 8 RTCOUT0 periods

17.5.7 System Controller Wake Up Inputs Register

Name: SUPC_WUIR

Address: 0x400E1420

Access: Read-write

31	30	29	28	27	26	25	24
WKUPT15	WKUPT14	WKUPT13	WKUPT12	WKUPT11	WKUPT10	WKUPT9	WKUPT8
23	22	21	20	19	18	17	16
WKUPT7	WKUPT6	WKUPT5	WKUPT4	WKUPT3	WKUPT2	WKUPT1	WKUPT0
15	14	13	12	11	10	9	8
WKUPEN15	WKUPEN14	WKUPEN13	WKUPEN12	WKUPEN11	WKUPEN10	WKUPEN9	WKUPEN8
7	6	5	4	3	2	1	0
WKUPEN7	WKUPEN6	WKUPEN5	WKUPEN4	WKUPEN3	WKUPEN2	WKUPEN1	WKUPEN0

- **WKUPEN0 - WKUPEN15: Wake Up Input Enable 0 to 15**

0 (DISABLE) = the corresponding wake-up input has no wake up effect.

1 (ENABLE) = the corresponding wake-up input forces the wake up of the core power supply.

- **WKUPT0 - WKUPT15: Wake Up Input Type 0 to 15**

0 (LOW) = a low level for a period defined by WKUPDBC on the corresponding wake-up input forces the wake up of the core power supply.

1 (HIGH) = a high level for a period defined by WKUPDBC on the corresponding wake-up input forces the wake up of the core power supply.

17.5.8 Supply Controller Status Register

Name: SUPC_SR
Address: 0x400E1424
Access: Read-write

31	30	29	28	27	26	25	24
WKUPIS15	WKUPIS14	WKUPIS13	WKUPIS12	WKUPIS11	WKUPIS10	WKUPIS9	WKUPIS8
23	22	21	20	19	18	17	16
WKUPIS7	WKUPIS6	WKUPIS5	WKUPIS4	WKUPIS3	WKUPIS2	WKUPIS1	WKUPIS0
15	14	13	12	11	10	9	8
–	LPDBCS1	LPDBCS0	–	–	–	–	–
7	6	5	4	3	2	1	0
OSCSEL	SMOS	SMS	SMRSTS	BODRSTS	SMWS	WKUPS	–

Note: Because of the asynchronism between the Slow Clock (SCLK) and the System Clock (MCK), the status register flag reset is taken into account only 2 slow clock cycles after the read of the SUPC_SR.

- **WKUPS: WKUP Wake Up Status**

0 (NO) = no wake up due to the assertion of the WKUP pins has occurred since the last read of SUPC_SR.

1 (PRESENT) = at least one wake up due to the assertion of the WKUP pins has occurred since the last read of SUPC_SR.

- **SMWS: Supply Monitor Detection Wake Up Status**

0 (NO) = no wake up due to a supply monitor detection has occurred since the last read of SUPC_SR.

1 (PRESENT) = at least one wake up due to a supply monitor detection has occurred since the last read of SUPC_SR.

- **BODRSTS: Brownout Detector Reset Status**

0 (NO) = no core brownout rising edge event has been detected since the last read of the SUPC_SR.

1 (PRESENT) = at least one brownout output rising edge event has been detected since the last read of the SUPC_SR.

When the voltage remains below the defined threshold, there is no rising edge event at the output of the brownout detection cell. The rising edge event occurs only when there is a voltage transition below the threshold.

- **SMRSTS: Supply Monitor Reset Status**

0 (NO) = no supply monitor detection has generated a core reset since the last read of the SUPC_SR.

1 (PRESENT) = at least one supply monitor detection has generated a core reset since the last read of the SUPC_SR.

- **SMS: Supply Monitor Status**

0 (NO) = no supply monitor detection since the last read of SUPC_SR.

1 (PRESENT) = at least one supply monitor detection since the last read of SUPC_SR.

- **SMOS: Supply Monitor Output Status**

0 (HIGH) = the supply monitor detected VDDIO higher than its threshold at its last measurement.

1 (LOW) = the supply monitor detected VDDIO lower than its threshold at its last measurement.

- **OSCSEL: 32-kHz Oscillator Selection Status**

0 (RC) = the slow clock, SLCK is generated by the embedded 32-kHz RC oscillator.

1 (CRYST) = the slow clock, SLCK is generated by the 32-kHz crystal oscillator.

- **LPDBCS0: Low Power Debouncer Wake Up Status on WKUP0**

0 (NO) = no wake up due to the assertion of the WKUP0 pin has occurred since the last read of SUPC_SR.

1 (PRESENT) = at least one wake up due to the assertion of the WKUP0 pin has occurred since the last read of SUPC_SR.

- **LPDBCS1: Low Power Debouncer Wake Up Status on WKUP1**

0 (NO) = no wake up due to the assertion of the WKUP1 pin has occurred since the last read of SUPC_SR.

1 (PRESENT) = at least one wake up due to the assertion of the WKUP1 pin has occurred since the last read of SUPC_SR.

- **WKUPIS0-WKUPIS15: WKUP Input Status 0 to 15**

0 (DIS) = the corresponding wake-up input is disabled, or was inactive at the time the debouncer triggered a wake up event.

1 (EN) = the corresponding wake-up input was active at the time the debouncer triggered a wake up event.

18. General Purpose Backup Registers (GPBR)

18.1 Description

The System Controller embeds Eight general-purpose backup registers.

18.2 Embedded Characteristics

- Eight 32-bit General Purpose Backup Registers

18.3 General Purpose Backup Registers (GPBR) User Interface

Table 18-1. Register Mapping

Offset	Register	Name	Access	Reset
0x0	General Purpose Backup Register 0	SYS_GPBR0	Read-write	–
...
0x1C	General Purpose Backup Register 7	SYS_GPBR7	Read-write	–



18.3.1 General Purpose Backup Register x

Name: SYS_GPBRx

Address: 0x400E1490

Access: Read-write

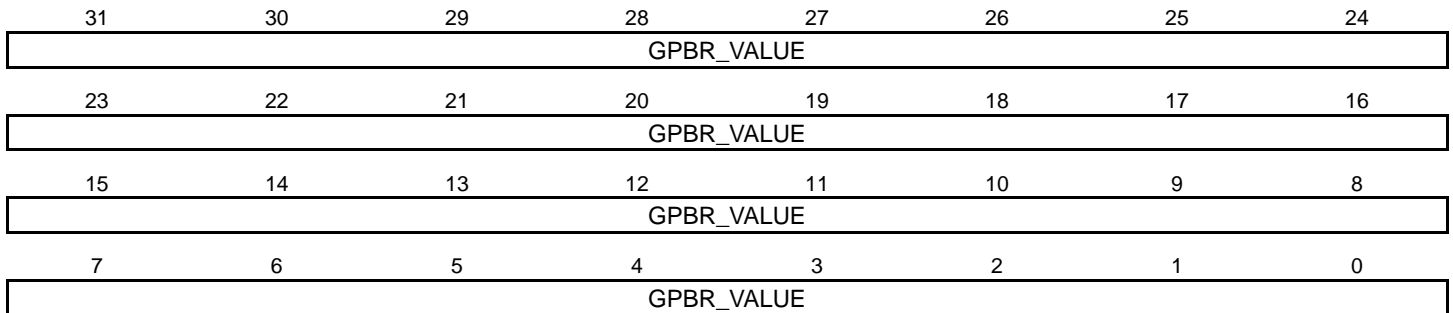

- **GPBR_VALUE:** Value of GPBR x



19. Enhanced Embedded Flash Controller (EEFC)

19.1 Description

The Enhanced Embedded Flash Controller (EEFC) ensures the interface of the Flash block with the 32-bit internal bus.

Its 128-bit or 64-bit wide memory interface increases performance. It also manages the programming, erasing, locking and unlocking sequences of the Flash using a full set of commands. One of the commands returns the embedded Flash descriptor definition that informs the system about the Flash organization, thus making the software generic.

19.2 Embedded Characteristics

- Interface of the Flash Block with the 32-bit Internal Bus
- Increases Performance in Thumb2 Mode with 128-bit or -64 bit Wide Memory Interface up to 100 MHz
- Code loops optimization
- 128 Lock Bits, Each Protecting a Lock Region
- GPNVMx General-purpose GPNVM Bits
- One-by-one Lock Bit Programming
- Commands Protected by a Keyword
- Erases the Entire Flash
- Erases by Plane
- Erase by Sector
- Erase by Pages
- Possibility of Erasing before Programming
- Locking and Unlocking Operations
- Consecutive Programming and Locking Operations
- Possibility to read the Calibration Bits

19.3 Product Dependencies

19.3.1 Power Management

The Enhanced Embedded Flash Controller (EEFC) is continuously clocked. The Power Management Controller has no effect on its behavior.

19.3.2 Interrupt Sources

The Enhanced Embedded Flash Controller (EEFC) interrupt line is connected to the Nested Vectored Interrupt Controller (NVIC). Using the Enhanced Embedded Flash Controller (EEFC) interrupt requires the NVIC to be programmed first. The EEFC interrupt is generated only on FRDY bit rising.

Table 19-1. Peripheral IDs

Instance	ID
EFC	6

19.4 Functional Description

19.4.1 Embedded Flash Organization

The embedded Flash interfaces directly with the 32-bit internal bus. The embedded Flash is composed of:

- One memory plane organized in several pages of the same size.
- Two 128-bit or 64-bit read buffers used for code read optimization.
- One 128-bit or 64-bit read buffer used for data read optimization.
- One write buffer that manages page programming. The write buffer size is equal to the page size. This buffer is write-only and accessible all along the 1 MByte address space, so that each word can be written to its final address.
- Several lock bits used to protect write/erase operation on several pages (lock region). A lock bit is associated with a lock region composed of several pages in the memory plane.
- Several bits that may be set and cleared through the Enhanced Embedded Flash Controller (EEFC) interface, called General Purpose Non Volatile Memory bits (GPNVM bits).

The embedded Flash size, the page size, the lock regions organization and GPNVM bits definition are described in the product definition section. The Enhanced Embedded Flash Controller (EEFC) returns a descriptor of the Flash controlled after a get descriptor command issued by the application (see [“Getting Embedded Flash Descriptor” on page 333](#)).

Figure 19-1. Embedded Flash Organization

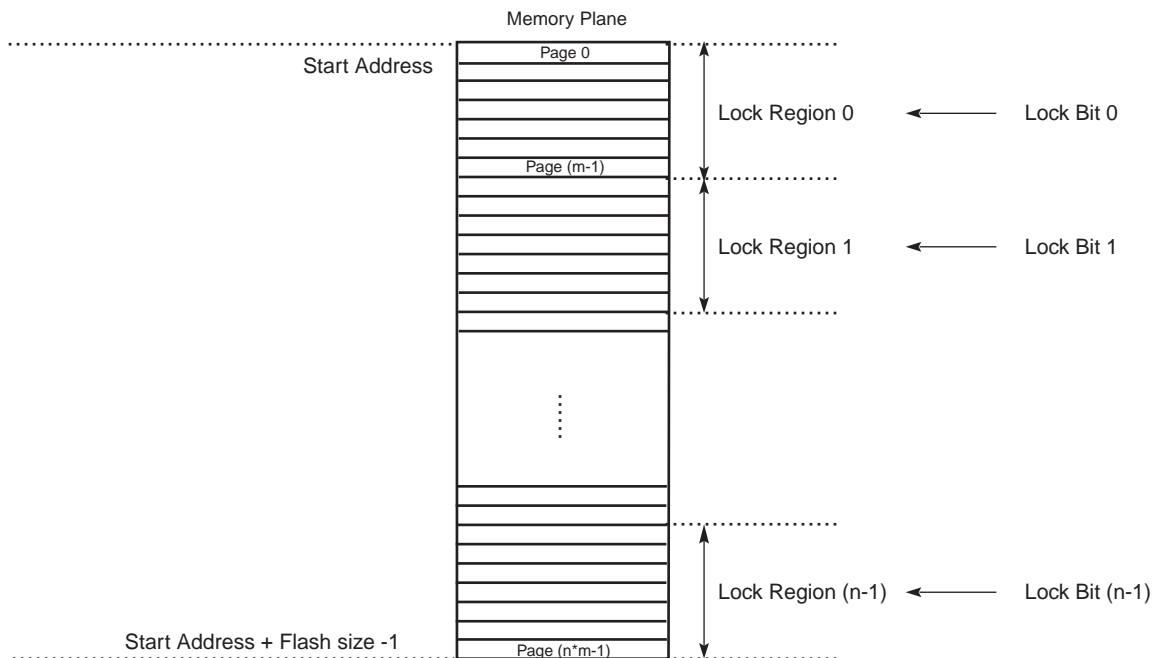

19.4.2 Read Operations

An optimized controller manages embedded Flash reads, thus increasing performance when the processor is running in Thumb2 mode by means of the 128- or 64- bit wide memory interface.

The Flash memory is accessible through 8-, 16- and 32-bit reads.

As the Flash block size is smaller than the address space reserved for the internal memory area, the embedded Flash wraps around the address space and appears to be repeated within it.

The read operations can be performed with or without wait states. Wait states must be programmed in the field FWS (Flash Read Wait State) in the Flash Mode Register (EEFC_FMR). Defining FWS to be 0 enables the single-cycle access of the embedded Flash. Refer to the Electrical Characteristics for more details.

19.4.2.1 128-bit or 64-bit Access Mode

By default the read accesses of the Flash are performed through a 128-bit wide memory interface. It enables better system performance especially when 2 or 3 wait state needed.

For systems requiring only 1 wait state, or to privilege current consumption rather than performance, the user can select a 64-bit wide memory access via the FAM bit in the Flash Mode Register (EEFC_FMR)

Please refer to the electrical characteristics section of the product datasheet for more details.

19.4.2.2 Code Read Optimization

This feature is enabled if the EEFC_FMR register bit SCOD is cleared.

A system of 2 x 128-bit or 2 x 64-bit buffers is added in order to optimize sequential Code Fetch.

Note: Immediate consecutive code read accesses are not mandatory to benefit from this optimization.

The sequential code read optimization is enabled by default. If the bit SCODIS in Flash Mode Register (EEFC_FMR) is set to 1, these buffers are disabled and the sequential code read is not optimized anymore.

Another system of 2 x 128-bit or 2 x 64-bit buffers is added in order to optimize loop code fetch. When a backward jump is inserted in the code, the pipeline of the sequential optimization is broken, and it becomes inefficient. In this case the loop code read optimization takes over from the sequential code read optimization to avoid insertion of wait states. The loop code read optimization is enabled by default. If in Flash Mode Register (EEFC_FMR), the bit CLOE is reset to 0 or the bit SCODIS is set to 1, these buffers are disabled and the loop code read is not optimized anymore.

Figure 19-2. Code Read Optimization for FWS = 0

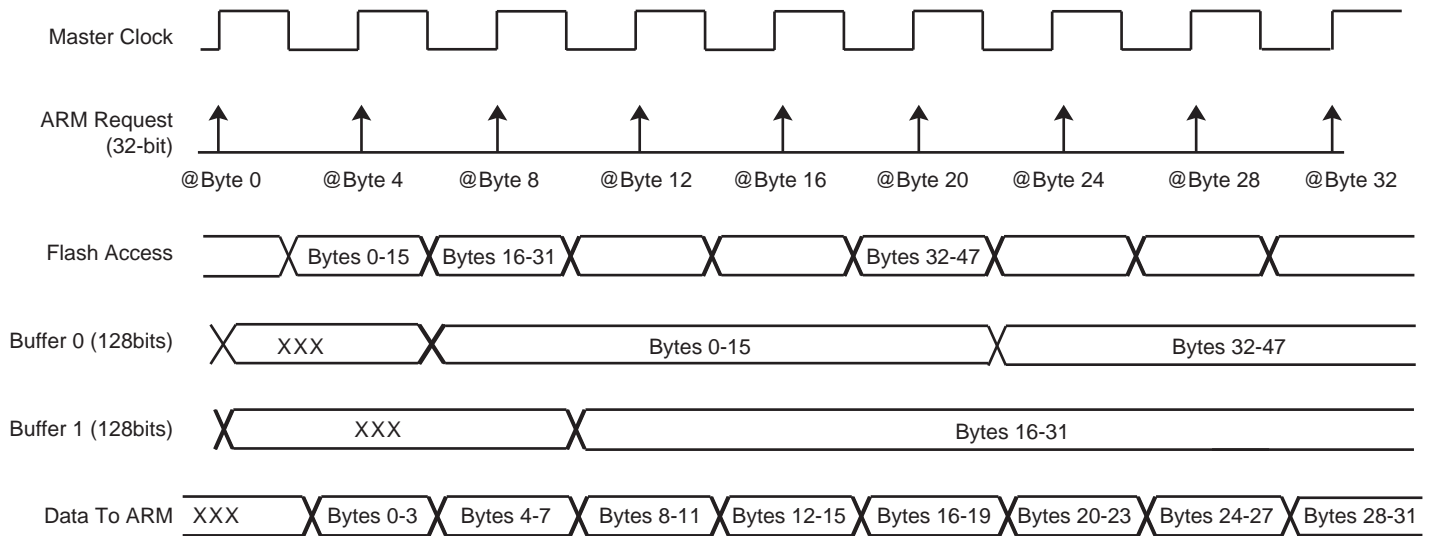

Note: When FWS is equal to 0, all the accesses are performed in a single-cycle access.

Figure 19-3. Code Read Optimization for FWS = 3

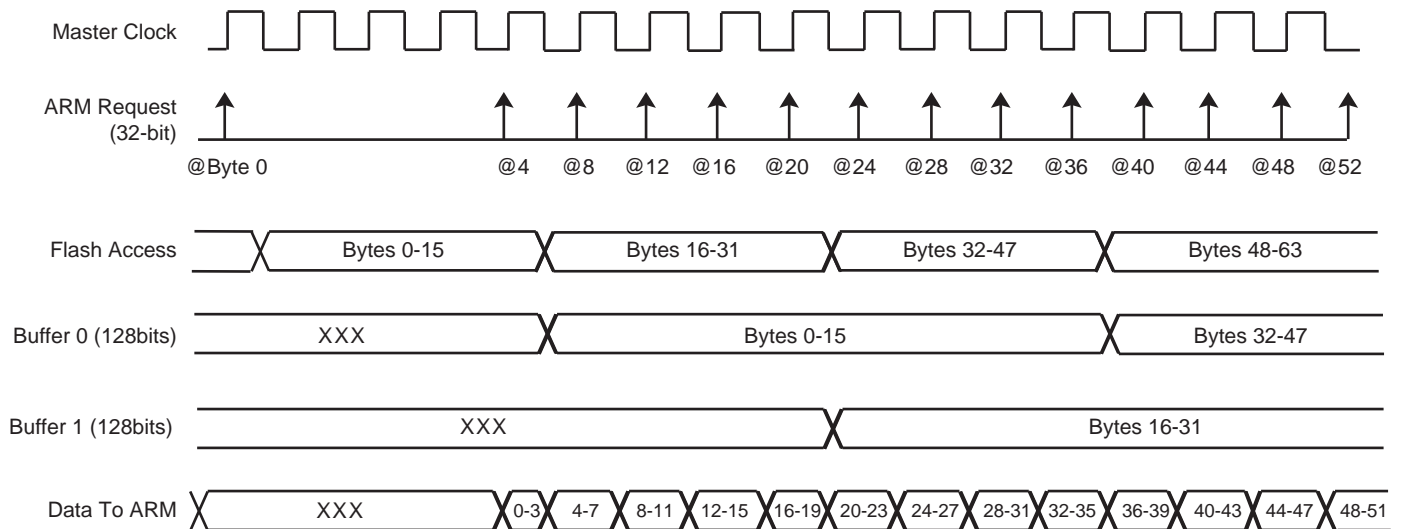

Note: When FWS is included between 1 and 3, in case of sequential reads, the first access takes (FWS+1) cycles, the other ones only 1 cycle.

19.4.2.3 Code Loops Optimization

The Code Loops optimization is enabled when the CLOE bit of the EEFC_FMR register is set at 1.

Figure 19-4 below illustrates the Code Loops optimization.

When this feature is enabled, if inner loop body instructions L_0 to L_n lay from the 128-bit flash memory cell M_{b0} to the memory cell M_{p1} , after recognition of a first backward branch, the two first flash memory cells M_{b0} and M_{b1} targeted by this branch are cached for fast access from the processor at the next loop iterations.

Afterwards, combining the sequential prefetch (described in [Section 19.4.2.2 "Code Read Optimization"](#)) through the loop body with the fast read access to the loop entry cache, the whole loop can be iterated with no wait-state.

Figure 19-4. Code Loops Optimization

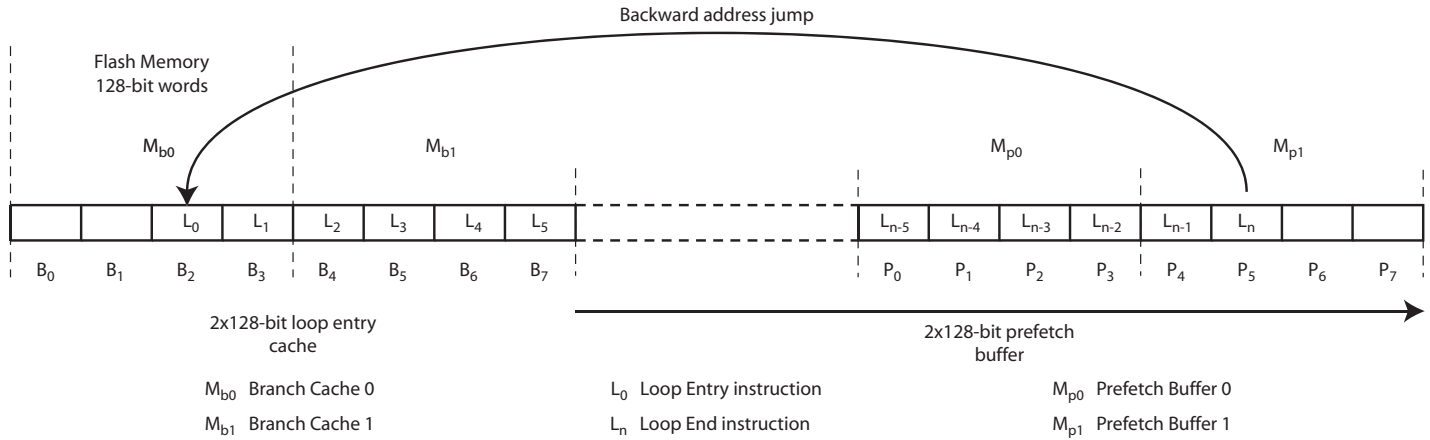

19.4.2.4 Data Read Optimization

The organization of the Flash in 128 bits (or 64 bits) is associated with two 128-bit (or 64-bit) prefetch buffers and one 128-bit (or 64-bit) data read buffer, thus providing maximum system performance. This buffer is added in order to store the requested data plus all the data contained in the 128-bit (64-bit) aligned data. This speeds up sequential data reads if, for example, FWS is equal to 1 (see [Figure 19-5](#)). The data read optimization is enabled by default. If the bit SCODIS in Flash Mode Register (EEFC_FMR) is set to 1, this buffer is disabled and the data read is not optimized anymore.

Note: No consecutive data read accesses are mandatory to benefit from this optimization.

Figure 19-5. Data Read Optimization for FWS = 1

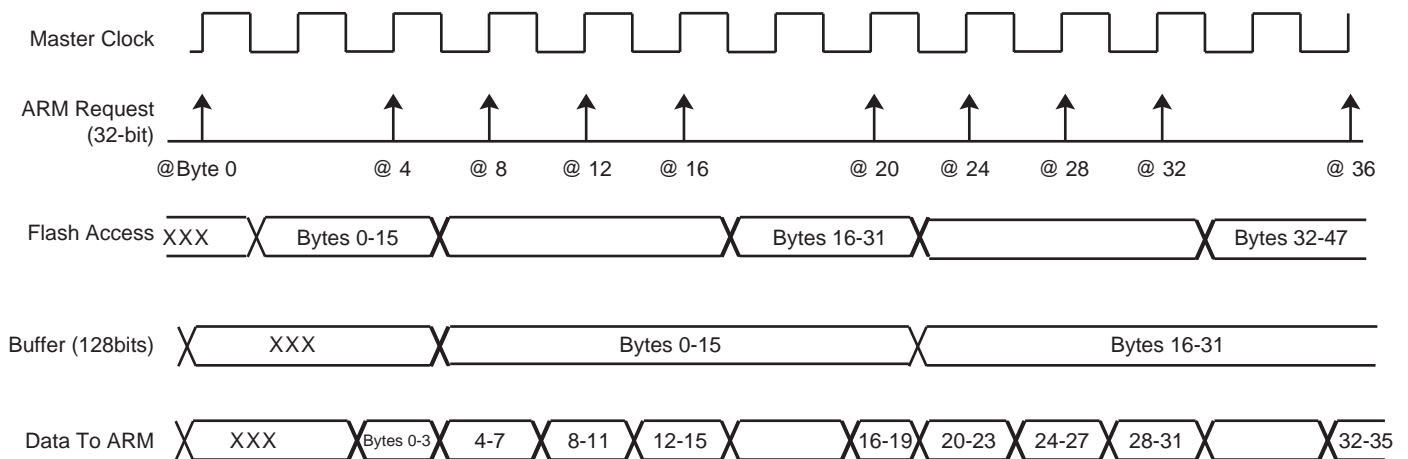

19.4.3 Flash Commands

The Enhanced Embedded Flash Controller (EEFC) offers a set of commands such as programming the memory Flash, locking and unlocking lock regions, consecutive programming and locking and full Flash erasing, etc.

Table 19-2. Set of Commands

Command	Value	Mnemonic
Get Flash Descriptor	0x00	GETD
Write page	0x01	WP
Write page and lock	0x02	WPL
Erase page and write page	0x03	EWP
Erase page and write page then lock	0x04	EWPL
Erase all	0x05	EA
Erase Pages	0x07	EPA
Set Lock Bit	0x08	SLB
Clear Lock Bit	0x09	CLB
Get Lock Bit	0x0A	GLB
Set GPNVM Bit	0x0B	SGPB
Clear GPNVM Bit	0x0C	CGPB
Get GPNVM Bit	0x0D	GGPB
Start Read Unique Identifier	0x0E	STUI
Stop Read Unique Identifier	0x0F	SPUI
Get CALIB Bit	0x10	GCALB
Erase Sector	0x11	ES
Write User Signature	0x12	WUS
Erase User Signature	0x13	EUS
Start Read User Signature	0x14	STUS
Stop Read User Signature	0x15	SPUS

In order to perform one of these commands, the Flash Command Register (EEFC_FCR) has to be written with the correct command using the FCMD field. As soon as the EEFC_FCR register is written, the FRDY flag and the FVALUE field in the EEFC_FRR register are automatically cleared. Once the current command is achieved, then the FRDY flag is automatically set. If an interrupt has been enabled by setting the FRDY bit in EEFC_FMR, the corresponding interrupt line of the NVIC is activated. (Note that this is true for all commands except for the STUI Command. The FRDY flag is not set when the STUI command is achieved.)

All the commands are protected by the same keyword, which has to be written in the 8 highest bits of the EEFC_FCR register.

Writing EEFC_FCR with data that does not contain the correct key and/or with an invalid command has no effect on the whole memory plane, but the FCMDE flag is set in the EEFC_FSR register. This flag is automatically cleared by a read access to the EEFC_FSR register.

When the current command writes or erases a page in a locked region, the command has no effect on the whole memory plane, but the FLOCKE flag is set in the EEFC_FSR register. This flag is automatically cleared by a read access to the EEFC_FSR register.

Figure 19-6. Command State Chart

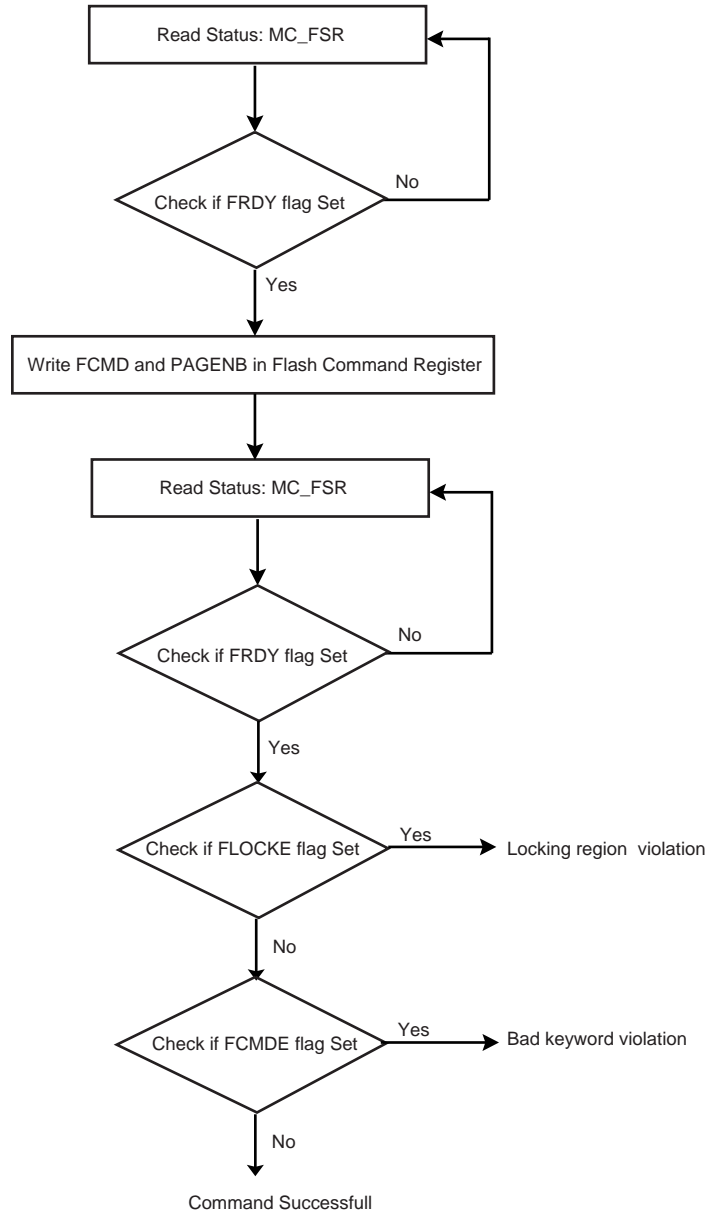

19.4.3.1 Getting Embedded Flash Descriptor

This command allows the system to learn about the Flash organization. The system can take full advantage of this information. For instance, a device could be replaced by one with more Flash capacity, and so the software is able to adapt itself to the new configuration.

To get the embedded Flash descriptor, the application writes the GETD command in the EEFC_FCR register. The first word of the descriptor can be read by the software application in the EEFC_FRR register as soon as the FRDY flag in the EEFC_FSR register rises. The next reads of the EEFC_FRR register provide the following word of the descriptor. If extra read operations to the EEFC_FRR register are done after the last word of the descriptor has been returned, then the EEFC_FRR register value is 0 until the next valid command.

Table 19-3. Flash Descriptor Definition

Symbol	Word Index	Description
FL_ID	0	Flash Interface Description
FL_SIZE	1	Flash size in bytes
FL_PAGE_SIZE	2	Page size in bytes
FL_NB_PLANE	3	Number of planes.
FL_PLANE[0]	4	Number of bytes in the first plane.
...		
FL_PLANE[FL_NB_PLANE-1]	4 + FL_NB_PLANE - 1	Number of bytes in the last plane.
FL_NB_LOCK	4 + FL_NB_PLANE	Number of lock bits. A bit is associated with a lock region. A lock bit is used to prevent write or erase operations in the lock region.
FL_LOCK[0]	4 + FL_NB_PLANE + 1	Number of bytes in the first lock region.
...		

19.4.3.2 Write Commands

Several commands can be used to program the Flash.

Flash technology requires that an erase be done before programming. The full memory plane can be erased at the same time, or several pages can be erased at the same time (refer to [Figure 19-7, "Example of Partial Page Programming"](#), and the paragraph below the figure.). Also, a page erase can be automatically done before a page write using EWP or EWPL commands.

After programming, the page (the whole lock region) can be locked to prevent miscellaneous write or erase sequences. The lock bit can be automatically set after page programming using WPL or EWPL commands.

Data to be written are stored in an internal latch buffer. The size of the latch buffer corresponds to the page size. The latch buffer wraps around within the internal memory area address space and is repeated as many times as the number of pages within this address space.

Note: Writing of 8-bit and 16-bit data is not allowed and may lead to unpredictable data corruption.

Write operations are performed in a number of wait states equal to the number of wait states for read operations.

Data are written to the latch buffer before the programming command is written to the Flash Command Register EEFC_FCR. The sequence is as follows:

- Write the full page, at any page address, within the internal memory area address space.
- Programming starts as soon as the page number and the programming command are written to the Flash Command Register. The FRDY bit in the Flash Programming Status Register (EEFC_FSR) is automatically cleared.
- When programming is completed, the FRDY bit in the Flash Programming Status Register (EEFC_FSR) rises. If an interrupt has been enabled by setting the bit FRDY in EEFC_FMR, the corresponding interrupt line of the NVIC is activated.

Two errors can be detected in the EEFC_FSR register after a programming sequence:

- Command Error: a bad keyword has been written in the EEFC_FCR register.
- Lock Error: the page to be programmed belongs to a locked region. A command must be previously run to unlock the corresponding region.
- Flash Error: at the end of the programming, the WriteVerify test of the Flash memory has failed.

By using the WP command, a page can be programmed in several steps if it has been erased before (see [Figure 19-7](#) below).

Figure 19-7. Example of Partial Page Programming

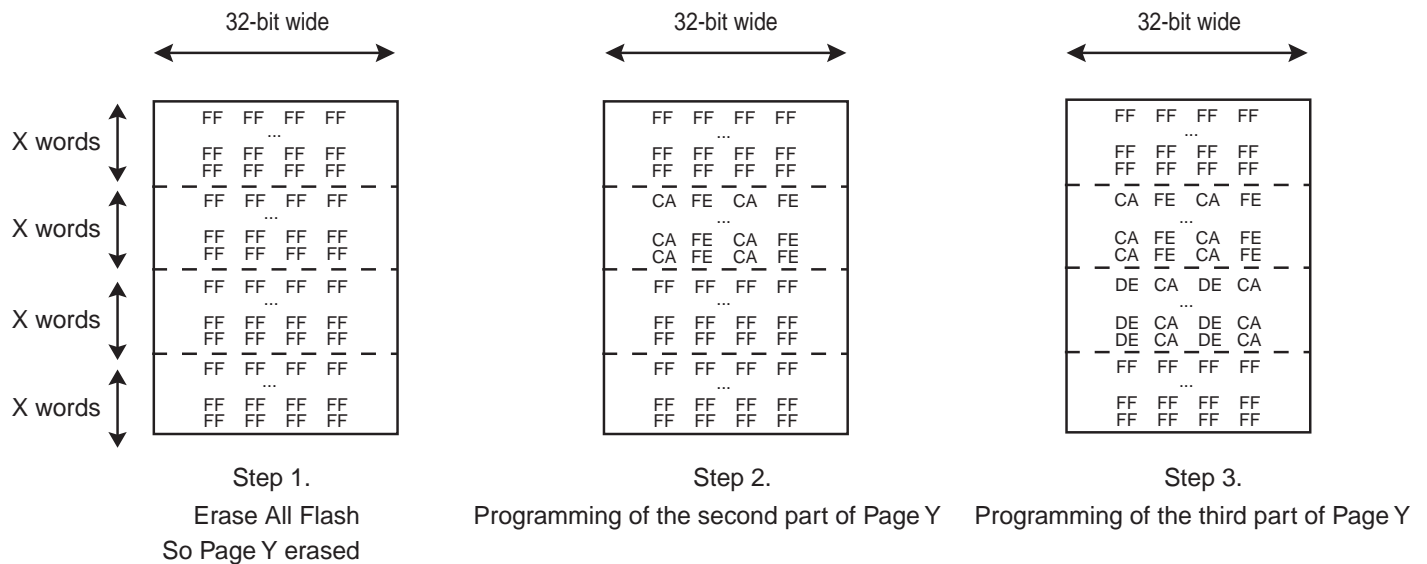

19.4.3.3 Erase Commands

Erase commands are allowed only on unlocked regions. Depending on the Flash memory, several commands can be used to erase the Flash:

- Erase all memory (EA): all memory is erased. The processor must not fetch code from the Flash memory.
- Erase pages (EPA): 4, 8, 16 or 32 pages are erased in the memory plane. The first page to be erased is specified in the FARG[15:2] field of the MC_FCR register. The first page number must be modulo 4, 8, 16 or 32 according to the number of pages to erase at the same time. The processor must not fetch code from the Flash memory.

- Erase Sector (ES): A full memory sector is erased. Sector size depends on the Flash memory. FARG must be set with a page number that is in the sector to be erased. The processor must not fetch code from the Flash memory.

The erase sequence is:

- Erase starts as soon as one of the erase commands and the FARG field are written in the Flash Command Register.
 - For the EPA command, the 2 lowest bits of the FARG field define the number of pages to be erased (FARG[1:0]):

Table 19-4. FARG Field for EPA command:

FARG[1:0]	Number of pages to be erased with EPA command
0	4 pages
1	8 pages
2	16 pages
3	32 pages

- When the programming completes, the FRDY bit in the Flash Programming Status Register (EEFC_FSR) rises. If an interrupt has been enabled by setting the FRDY bit in EEFC_FMR, the interrupt line of the NVIC is activated.

Two errors can be detected in the EEFC_FSR register after a programming sequence:

- Command Error: a bad keyword has been written in the EEFC_FCR register.
- Lock Error: at least one page to be erased belongs to a locked region. The erase command has been refused, no page has been erased. A command must be run previously to unlock the corresponding region.
- Flash Error: at the end of the programming, the EraseVerify test of the Flash memory has failed.

19.4.3.4 Lock Bit Protection

Lock bits are associated with several pages in the embedded Flash memory plane. This defines lock regions in the embedded Flash memory plane. They prevent writing/erasing protected pages.

The lock sequence is:

- The Set Lock command (SLB) and a page number to be protected are written in the Flash Command Register.
- When the locking completes, the FRDY bit in the Flash Programming Status Register (EEFC_FSR) rises. If an interrupt has been enabled by setting the FRDY bit in EEFC_FMR, the interrupt line of the NVIC is activated.
- If the lock bit number is greater than the total number of lock bits, then the command has no effect. The result of the SLB command can be checked running a GLB (Get Lock Bit) command.

One error can be detected in the EEFC_FSR register after a programming sequence:

- Command Error: a bad keyword has been written in the EEFC_FCR register.
- Flash Error: at the end of the programming, the EraseVerify or WriteVerify test of the Flash memory has failed.

It is possible to clear lock bits previously set. Then the locked region can be erased or programmed. The unlock sequence is:

- The Clear Lock command (CLB) and a page number to be unprotected are written in the Flash Command Register.
- When the unlock completes, the FRDY bit in the Flash Programming Status Register (EEFC_FSR) rises. If an interrupt has been enabled by setting the FRDY bit in EEFC_FMR, the interrupt line of the NVIC is activated.
- If the lock bit number is greater than the total number of lock bits, then the command has no effect.

One error can be detected in the EEFC_FSR register after a programming sequence:

- Command Error: a bad keyword has been written in the EEFC_FCR register.
- Flash Error: at the end of the programming, the EraseVerify or WriteVerify test of the Flash memory has failed.

The status of lock bits can be returned by the Enhanced Embedded Flash Controller (EEFC). The Get Lock Bit status sequence is:

- The Get Lock Bit command (GLB) is written in the Flash Command Register, FARG field is meaningless.
- Lock bits can be read by the software application in the EEFC_FRR register. The first word read corresponds to the 32 first lock bits, next reads providing the next 32 lock bits as long as it is meaningful. Extra reads to the EEFC_FRR register return 0.

For example, if the third bit of the first word read in the EEFC_FRR is set, then the third lock region is locked.

One error can be detected in the EEFC_FSR register after a programming sequence:

- Command Error: a bad keyword has been written in the EEFC_FCR register.
- Flash Error: at the end of the programming, the EraseVerify or WriteVerify test of the Flash memory has failed.

Note: Access to the Flash in read is permitted when a set, clear or get lock bit command is performed.

19.4.3.5 GPNVM Bit

GPNVM bits do not interfere with the embedded Flash memory plane. Refer to the product definition section for information on the GPNVM Bit Action.

The set GPNVM bit sequence is:

- Start the Set GPNVM Bit command (SGPB) by writing the Flash Command Register with the SGPB command and the number of the GPNVM bit to be set.
- When the GPNVM bit is set, the bit FRDY in the Flash Programming Status Register (EEFC_FSR) rises. If an interrupt was enabled by setting the FRDY bit in EEFC_FMR, the interrupt line of the NVIC is activated.
- If the GPNVM bit number is greater than the total number of GPNVM bits, then the command has no effect. The result of the SGPB command can be checked by running a GGPB (Get GPNVM Bit) command.

One error can be detected in the EEFC_FSR register after a programming sequence:

- Command Error: a bad keyword has been written in the EEFC_FCR register.

- Flash Error: at the end of the programming, the EraseVerify or WriteVerify test of the Flash memory has failed.

It is possible to clear GPNVM bits previously set. The clear GPNVM bit sequence is:

- Start the Clear GPNVM Bit command (CGPB) by writing the Flash Command Register with CGPB and the number of the GPNVM bit to be cleared.
- When the clear completes, the FRDY bit in the Flash Programming Status Register (EEFC_FSR) rises. If an interrupt has been enabled by setting the FRDY bit in EEFC_FMR, the interrupt line of the NVIC is activated.
- If the GPNVM bit number is greater than the total number of GPNVM bits, then the command has no effect.

One error can be detected in the EEFC_FSR register after a programming sequence:

- Command Error: a bad keyword has been written in the EEFC_FCR register.
- Flash Error: at the end of the programming, the EraseVerify or WriteVerify test of the Flash memory has failed.

The status of GPNVM bits can be returned by the Enhanced Embedded Flash Controller (EEFC). The sequence is:

- Start the Get GPNVM bit command by writing the Flash Command Register with GGPB. The FARG field is meaningless.
- GPNVM bits can be read by the software application in the EEFC_FRR register. The first word read corresponds to the 32 first GPNVM bits, following reads provide the next 32 GPNVM bits as long as it is meaningful. Extra reads to the EEFC_FRR register return 0.

For example, if the third bit of the first word read in the EEFC_FRR is set, then the third GPNVM bit is active.

One error can be detected in the EEFC_FSR register after a programming sequence:

- Command Error: a bad keyword has been written in the EEFC_FCR register.

Note: Access to the Flash in read is permitted when a set, clear or get GPNVM bit command is performed.

19.4.3.6 Calibration Bit

Calibration bits do not interfere with the embedded Flash memory plane.

It is impossible to modify the calibration bits.

The status of calibration bits can be returned by the Enhanced Embedded Flash Controller (EEFC). The sequence is:

- Issue the Get CALIB Bit command by writing the Flash Command Register with GCALB (see [Table 19-2](#)). The FARG field is meaningless.
- Calibration bits can be read by the software application in the EEFC_FRR register. The first word read corresponds to the 32 first calibration bits, following reads provide the next 32 calibration bits as long as it is meaningful. Extra reads to the EEFC_FRR register return 0.

The 4/8/12 MHz Fast RC oscillator is calibrated in production. This calibration can be read through the Get CALIB Bit command. The table below shows the bit implementation for each frequency:

RC Calibration Frequency	EEFC_FRR Bits
8 MHz output	[28 - 22]
12 MHz output	[38 - 32]

The RC calibration for 4 MHz is set to 1,000,000.

19.4.3.7 Security Bit Protection

When the security is enabled, access to the Flash, either through the JTAG/SWD interface or through the Fast Flash Programming Interface, is forbidden. This ensures the confidentiality of the code programmed in the Flash.

The security bit is GPNVM0.

Disabling the security bit can only be achieved by asserting the ERASE pin at 1, and after a full Flash erase is performed. When the security bit is deactivated, all accesses to the Flash are permitted.

19.4.3.8 Unique Identifier

Each part is programmed with a 128-bit Unique Identifier. It can be used to generate keys for example.

To read the Unique Identifier the sequence is:

- Send the Start Read unique Identifier command (STUI) by writing the Flash Command Register with the STUI command.
- When the Unique Identifier is ready to be read, the FRDY bit in the Flash Programming Status Register (EEFC_FSR) falls.
- The Unique Identifier is located in the first 128 bits of the Flash memory mapping, thus, at the address 0x00400000-0x004003FF.
- To stop the Unique Identifier mode, the user needs to send the Stop Read unique Identifier command (SPUI) by writing the Flash Command Register with the SPUI command.
- When the Stop read Unique Identifier command (SPUI) has been performed, the FRDY bit in the Flash Programming Status Register (EEFC_FSR) rises. If an interrupt was enabled by setting the FRDY bit in EEFC_FMR, the interrupt line of the NVIC is activated.

Note that during the sequence, the software can not run out of Flash (or the second plane in case of dual plane).

19.4.3.9 User Signature

Each part contains a User Signature of 512-bytes. It can be used by the user for storage. Read, write and erase of this area is allowed.

To read the User Signature, the sequence is as follows:

- Send the Start Read User Signature command (STUS) by writing the Flash Command Register with the STUS command.
- When the User Signature is ready to be read, the FRDY bit in the Flash Programming Status Register (EEFC_FSR) falls.

- The User Signature is located in the first 512 bytes of the Flash memory mapping, thus, at the address 0x00400000-0x004001FF.
- To stop the User Signature mode, the user needs to send the Stop Read User Signature command (SPUS) by writing the Flash Command Register with the SPUS command.
- When the Stop Read User Signature command (SPUI) has been performed, the FRDY bit in the Flash Programming Status Register (EEFC_FSR) rises. If an interrupt was enabled by setting the FRDY bit in EEFC_FMR, the interrupt line of the NVIC is activated.

Note that during the sequence, the software can not run out of Flash (or the second plane, in case of dual plane).

One error can be detected in the EEFC_FSR register after this sequence:

- Command Error: a bad keyword has been written in the EEFC_FCR register.

To write the User Signature, the sequence is:

- Write the full page, at any page address, within the internal memory area address space.
- Send the Write User Signature command (WUS) by writing the Flash Command Register with the WUS command.
- When programming is completed, the FRDY bit in the Flash Programming Status Register (EEFC_FSR) rises. If an interrupt has been enabled by setting the FRDY bit in EEFC_FMR, the corresponding interrupt line of the NVIC is activated.

Two errors can be detected in the EEFC_FSR register after this sequence:

- Command Error: a bad keyword has been written in the EEFC_FCR register.
- Flash Error: at the end of the programming, the WriteVerify test of the Flash memory has failed.

To erase the User Signature, the sequence is:

- Send the Erase User Signature command (EUS) by writing the Flash Command Register with the EUS command.
- When programming is completed, the FRDY bit in the Flash Programming Status Register (EEFC_FSR) rises. If an interrupt has been enabled by setting the FRDY bit in EEFC_FMR, the corresponding interrupt line of the NVIC is activated.

Two errors can be detected in the EEFC_FSR register after this sequence:

- Command Error: a bad keyword has been written in the EEFC_FCR register.
- Flash Error: at the end of the programming, the EraseVerify test of the Flash memory has failed.

19.5 Enhanced Embedded Flash Controller (EEFC) User Interface

The User Interface of the Enhanced Embedded Flash Controller (EEFC) is integrated within the System Controller with the base address of 0x400E0A00.

Table 19-5. Register Mapping

Offset	Register	Name	Access	Reset State
0x00	EEFC Flash Mode Register	EEFC_FMR	Read-write	0x0400_0000
0x04	EEFC Flash Command Register	EEFC_FCR	Write-only	–
0x08	EEFC Flash Status Register	EEFC_FSR	Read-only	0x00000001
0x0C	EEFC Flash Result Register	EEFC_FRR	Read-only	0x0
0x10	Reserved	–	–	–

19.5.1 EEFC Flash Mode Register

Name: EEFC_FMR
Address: 0x400E0A00
Access: Read-write
Offset: 0x00

31	30	29	28	27	26	25	24
–	–	–	–	–	CLOE	–	FAM
23	22	21	20	19	18	17	16
–	–	–	–	–	–	–	SCOD
15	14	13	12	11	10	9	8
–	–	–	–	FWS			
7	6	5	4	3	2	1	0
–	–	–	–	–	–	–	FRDY

- **FRDY: Ready Interrupt Enable**

0: Flash Ready does not generate an interrupt.
 1: Flash Ready (to accept a new command) generates an interrupt.

- **FWS: Flash Wait State**

This field defines the number of wait states for read and write operations:

$$\text{Number of cycles for Read/Write operations} = \text{FWS} + 1$$

- **SCOD: Sequential Code Optimization Disable**

0: The sequential code optimization is enabled.
 1: The sequential code optimization is disabled.

No Flash read should be done during change of this register.

- **FAM: Flash Access Mode**

0: 128-bit access in read Mode only, to enhance access speed.
 1: 64-bit access in read Mode only, to enhance power consumption.

No Flash read should be done during change of this register.

- **CLOE: Code Loops Optimization Enable**

0: The opcode loops optimization is disabled.
 1: The opcode loops optimization is enabled.

No Flash read should be done during change of this register.

19.5.2 EEFC Flash Command Register

Name: EEFC_FCR
Address: 0x400E0A04
Access: Write-only
Offset: 0x04

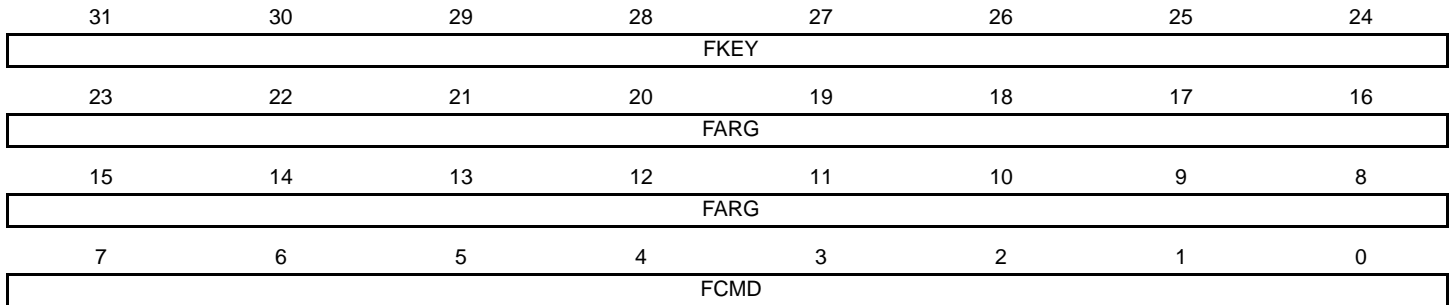

- **FCMD: Flash Command**

This field defines the Flash commands. Refer to [“Flash Commands” on page 331](#).

- **FARG: Flash Command Argument**

Erase all command	Field is meaningless.
Erase plane command	FARG must be set with a page number that is in the memory plane to be erased.
Erase sector command	FARG must be set with a page number that is in the sector to be erased.
Erase pages command	FARG[15:2] defines the page from which the erase will start. This page must be modulo 4, 8, 16 or 32 according to the number of pages to erase. FARG[1:0] defines the number of pages to be erased. Refer to Table 19-4 on page 335
Programming command	FARG defines the page number to be programmed.
Lock command	FARG defines the page number to be locked.
GPNVM command	FARG defines the GPNVM number.

- **FKEY: Flash Writing Protection Key**

This field should be written with the value 0x5A to enable the command defined by the bits of the register. If the field is written with a different value, the write is not performed and no action is started.

19.5.3 EEFC Flash Status Register

Name: EEFC_FSR
Address: 0x400E0A08
Access: Read-only
Offset: 0x08

31	30	29	28	27	26	25	24
–	–	–	–	–	–	–	–
23	22	21	20	19	18	17	16
–	–	–	–	–	–	–	–
15	14	13	12	11	10	9	8
–	–	–	–	–	–	–	–
7	6	5	4	3	2	1	0
–	–	–	–	FLERR	FLOCKE	FCMDE	FRDY

- **FRDY: Flash Ready Status**

0: The Enhanced Embedded Flash Controller (EEFC) is busy.

1: The Enhanced Embedded Flash Controller (EEFC) is ready to start a new command.

When it is set, this flag triggers an interrupt if the FRDY flag is set in the EEFC_FMR register.

This flag is automatically cleared when the Enhanced Embedded Flash Controller (EEFC) is busy.

- **FCMDE: Flash Command Error Status**

0: No invalid commands and no bad keywords were written in the Flash Mode Register EEFC_FMR.

1: An invalid command and/or a bad keyword was/were written in the Flash Mode Register EEFC_FMR.

This flag is automatically cleared when EEFC_FSR is read or EEFC_FCR is written.

- **FLOCKE: Flash Lock Error Status**

0: No programming/erase of at least one locked region has happened since the last read of EEFC_FSR.

1: Programming/erase of at least one locked region has happened since the last read of EEFC_FSR.

This flag is automatically cleared when EEFC_FSR is read or EEFC_FCR is written.

- **FLERR: Flash Error Status**

0: No Flash Memory error occurred at the end of programming (EraseVerify or WriteVerify test has passed).

1: A Flash Memory error occurred at the end of programming (EraseVerify or WriteVerify test has failed).

19.5.4 EEFC Flash Result Register

Name: EEFC_FRR
Address: 0x400E0A0C
Access: Read-only
Offset: 0x0C

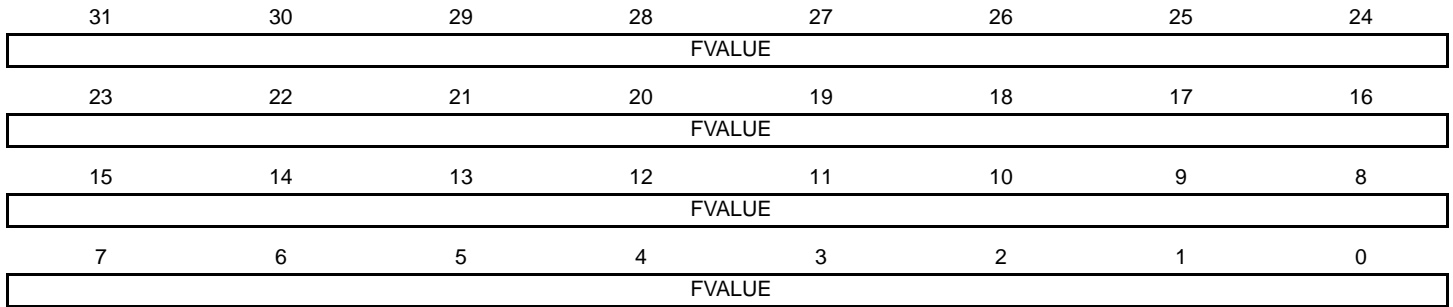

- **FVALUE: Flash Result Value**

The result of a Flash command is returned in this register. If the size of the result is greater than 32 bits, then the next resulting value is accessible at the next register read.

20. Fast Flash Programming Interface (FFPI)

20.1 Description

The Fast Flash Programming Interface (FFPI) provides parallel high-volume programming using a standard gang programmer. The parallel interface is fully handshaked and the device is considered to be a standard EEPROM. Additionally, the parallel protocol offers an optimized access to all the embedded Flash functionalities.

Although the Fast Flash Programming Mode is a dedicated mode for high volume programming, this mode is not designed for in-situ programming.

20.2 Parallel Fast Flash Programming

20.2.1 Device Configuration

In Fast Flash Programming Mode, the device is in a specific test mode. Only a certain set of pins is significant. The rest of the PIOs are used as inputs with a pull-up. The crystal oscillator is in bypass mode. Other pins must be left unconnected.

Figure 20-1. SAM4SxB/C (64/100 pins) Parallel Programming Interface

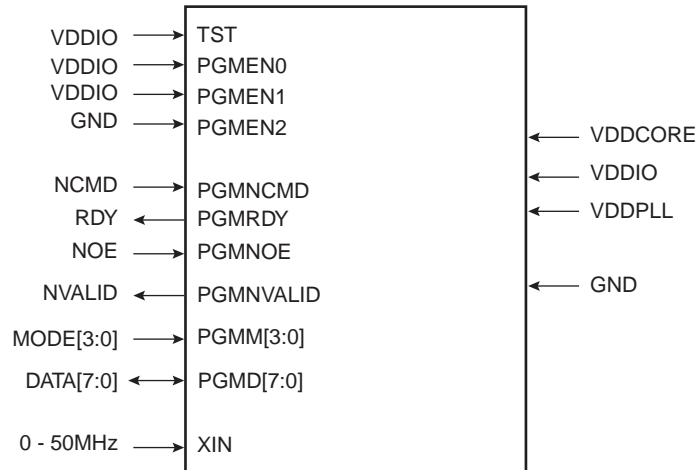

Table 20-1. Signal Description List

Signal Name	Function	Type	Active Level	Comments
Power				
VDDIO	I/O Lines Power Supply	Power		
VDDCORE	Core Power Supply	Power		
VDDPLL	PLL Power Supply	Power		
GND	Ground	Ground		
Clocks				
XIN	Main Clock Input.	Input		32KHz to 50MHz
Test				
TST	Test Mode Select	Input	High	Must be connected to VDDIO
PGMEN0	Test Mode Select	Input	High	Must be connected to VDDIO
PGMEN1	Test Mode Select	Input	High	Must be connected to VDDIO
PGMEN2	Test Mode Select	Input	Low	Must be connected to GND
PIO				
PGMNCMD	Valid command available	Input	Low	Pulled-up input at reset
PGMRDY	0: Device is busy 1: Device is ready for a new command	Output	High	Pulled-up input at reset

Table 20-1. Signal Description List (Continued)

Signal Name	Function	Type	Active Level	Comments
PGMNOE	Output Enable (active high)	Input	Low	Pulled-up input at reset
PGMNVALID	0: DATA[15:0] is in input mode 1: DATA[15:0] is in output mode	Output	Low	Pulled-up input at reset
PGMM[3:0]	Specifies DATA type (See Table 20-2)	Input		Pulled-up input at reset
PGMD[15:0]	Bi-directional data bus	Input/Output		Pulled-up input at reset

20.2.2 Signal Names

Depending on the MODE settings, DATA is latched in different internal registers.

Table 20-2. Mode Coding

MODE[3:0]	Symbol	Data
0000	CMDE	Command Register
0001	ADDR0	Address Register LSBs
0010	ADDR1	
0011	ADDR2	
0100	ADDR3	Address Register MSBs
0101	DATA	Data Register
Default	IDLE	No register

When MODE is equal to CMDE, then a new command (strobed on DATA[15:0] signals) is stored in the command register.

Table 20-3. Command Bit Coding

DATA[15:0]	Symbol	Command Executed
0x0011	READ	Read Flash
0x0012	WP	Write Page Flash
0x0022	WPL	Write Page and Lock Flash
0x0032	EWP	Erase Page and Write Page
0x0042	EWPL	Erase Page and Write Page then Lock
0x0013	EA	Erase All
0x0014	SLB	Set Lock Bit
0x0024	CLB	Clear Lock Bit
0x0015	GLB	Get Lock Bit
0x0034	SGPB	Set General Purpose NVM bit
0x0044	CGPB	Clear General Purpose NVM bit
0x0025	GGPB	Get General Purpose NVM bit
0x0054	SSE	Set Security Bit

Table 20-3. Command Bit Coding (Continued)

DATA[15:0]	Symbol	Command Executed
0x0035	GSE	Get Security Bit
0x001F	WRAM	Write Memory
0x001E	GVE	Get Version

20.2.3 Entering Programming Mode

The following algorithm puts the device in Parallel Programming Mode:

- Apply GND, VDDIO, VDDCORE and VDDPLL.
- Apply XIN clock within T_{POR_RESET} if an external clock is available.
- Wait for T_{POR_RESET}
- Start a read or write handshaking.

Note: After reset, the device is clocked by the internal RC oscillator. Before clearing RDY signal, if an external clock (> 32 kHz) is connected to XIN, then the device switches on the external clock. Else, XIN input is not considered. A higher frequency on XIN speeds up the programmer handshake.

20.2.4 Programmer Handshaking

An handshake is defined for read and write operations. When the device is ready to start a new operation (RDY signal set), the programmer starts the handshake by clearing the NCMD signal. The handshaking is achieved once NCMD signal is high and RDY is high.

20.2.4.1 Write Handshaking

For details on the write handshaking sequence, refer to [Figure 20-2](#) and [Table 20-4](#).

Figure 20-2. SAM4SxB/C (64/100 pins) Parallel Programming Timing, Write Sequence

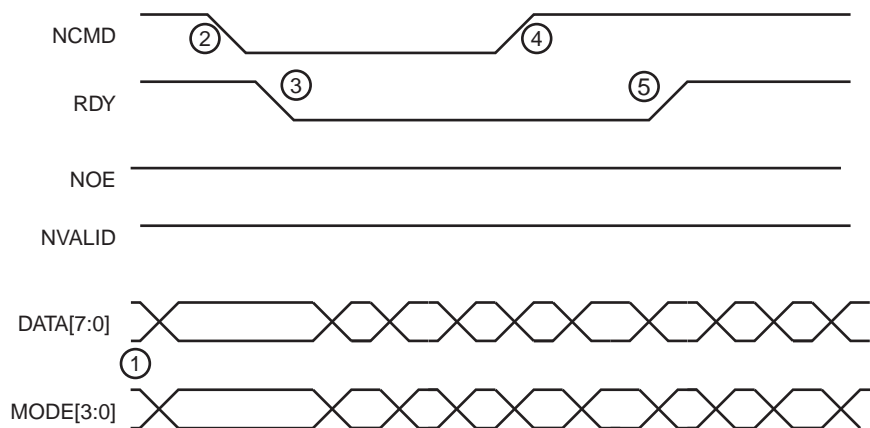

Table 20-4. Write Handshake

Step	Programmer Action	Device Action	Data I/O
1	Sets MODE and DATA signals	Waits for NCMD low	Input
2	Clears NCMD signal	Latches MODE and DATA	Input
3	Waits for RDY low	Clears RDY signal	Input
4	Releases MODE and DATA signals	Executes command and polls NCMD high	Input
5	Sets NCMD signal	Executes command and polls NCMD high	Input
6	Waits for RDY high	Sets RDY	Input

20.2.4.2 Read Handshaking

For details on the read handshaking sequence, refer to [Figure 20-3](#) and [Table 20-5](#).

Figure 20-3. SAM4SxB/C (64/100 pins) Parallel Programming Timing, Read Sequence

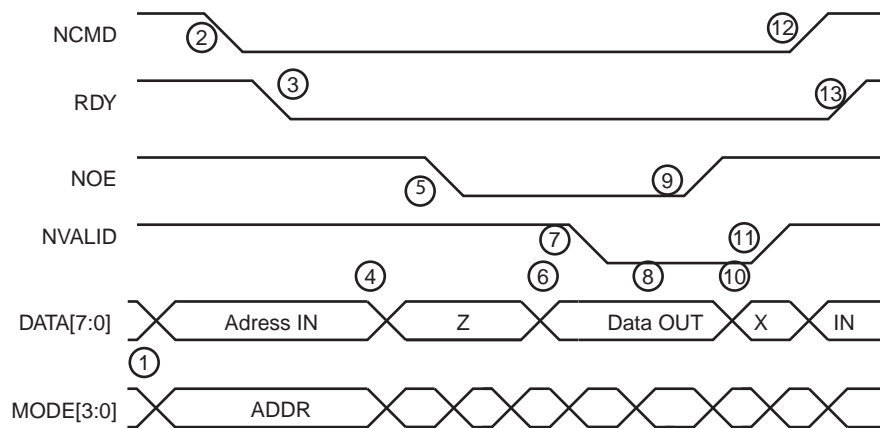

Table 20-5. Read Handshake

Step	Programmer Action	Device Action	DATA I/O
1	Sets MODE and DATA signals	Waits for NCMD low	Input
2	Clears NCMD signal	Latch MODE and DATA	Input
3	Waits for RDY low	Clears RDY signal	Input
4	Sets DATA signal in tristate	Waits for NOE Low	Input
5	Clears NOE signal		Tristate
6	Waits for NVALID low	Sets DATA bus in output mode and outputs the flash contents.	Output
7		Clears NVALID signal	Output
8	Reads value on DATA Bus	Waits for NOE high	Output

Table 20-5. Read Handshake (Continued)

Step	Programmer Action	Device Action	DATA I/O
9	Sets NOE signal		Output
10	Waits for NVALID high	Sets DATA bus in input mode	X
11	Sets DATA in output mode	Sets NVALID signal	Input
12	Sets NCMD signal	Waits for NCMD high	Input
13	Waits for RDY high	Sets RDY signal	Input

20.2.5 Device Operations

Several commands on the Flash memory are available. These commands are summarized in [Table 20-3 on page 347](#). Each command is driven by the programmer through the parallel interface running several read/write handshaking sequences.

When a new command is executed, the previous one is automatically achieved. Thus, chaining a read command after a write automatically flushes the load buffer in the Flash.

In the following table:

- **DATA[15:0] pertains to SAM4SxB/C (64/100 pins)**

20.2.5.1 Flash Read Command

This command is used to read the contents of the Flash memory. The read command can start at any valid address in the memory plane and is optimized for consecutive reads. Read handshaking can be chained; an internal address buffer is automatically increased.

Table 20-6. Read Command

Step	Handshake Sequence	MODE[3:0]	DATA[15:0]
1	Write handshaking	CMDE	READ
2	Write handshaking	ADDR0	Memory Address LSB
3	Write handshaking	ADDR1	Memory Address
4	Read handshaking	DATA	*Memory Address++
5	Read handshaking	DATA	*Memory Address++
...
n	Write handshaking	ADDR0	Memory Address LSB
n+1	Write handshaking	ADDR1	Memory Address
n+2	Read handshaking	DATA	*Memory Address++
n+3	Read handshaking	DATA	*Memory Address++
...

20.2.5.2 Flash Write Command

This command is used to write the Flash contents.

The Flash memory plane is organized into several pages. Data to be written are stored in a load buffer that corresponds to a Flash memory page. The load buffer is automatically flushed to the Flash:

- Before access to any page other than the current one
- When a new command is validated (MODE = CMDE)

The Write Page command (WP) is optimized for consecutive writes. Write handshaking can be chained; an internal address buffer is automatically increased.

Table 20-7. Write Command

Step	Handshake Sequence	MODE[3:0]	DATA[15:0]
1	Write handshaking	CMDE	WP or WPL or EWP or EWPL
2	Write handshaking	ADDR0	Memory Address LSB
3	Write handshaking	ADDR1	Memory Address
4	Write handshaking	DATA	*Memory Address++
5	Write handshaking	DATA	*Memory Address++
...
n	Write handshaking	ADDR0	Memory Address LSB
n+1	Write handshaking	ADDR1	Memory Address
n+2	Write handshaking	DATA	*Memory Address++
n+3	Write handshaking	DATA	*Memory Address++
...

The Flash command Write Page and Lock (WPL) is equivalent to the Flash Write Command. However, the lock bit is automatically set at the end of the Flash write operation. As a lock region is composed of several pages, the programmer writes to the first pages of the lock region using Flash write commands and writes to the last page of the lock region using a Flash write and lock command.

The Flash command Erase Page and Write (EWP) is equivalent to the Flash Write Command. However, before programming the load buffer, the page is erased.

The Flash command Erase Page and Write the Lock (EWPL) combines EWP and WPL commands.

20.2.5.3 Flash Full Erase Command

This command is used to erase the Flash memory planes.

All lock regions must be unlocked before the Full Erase command by using the CLB command. Otherwise, the erase command is aborted and no page is erased.

Table 20-8. Full Erase Command

Step	Handshake Sequence	MODE[3:0]	DATA[15:0]
1	Write handshaking	CMDE	EA
2	Write handshaking	DATA	0

20.2.5.4 Flash Lock Commands

Lock bits can be set using WPL or EWPL commands. They can also be set by using the Set Lock command (SLB). With this command, several lock bits can be activated. A Bit Mask is provided as argument to the command. When bit 0 of the bit mask is set, then the first lock bit is activated.

In the same way, the Clear Lock command (CLB) is used to clear lock bits.

Table 20-9. Set and Clear Lock Bit Command

Step	Handshake Sequence	MODE[3:0]	DATA[15:0]
1	Write handshaking	CMDE	SLB or CLB
2	Write handshaking	DATA	Bit Mask

Lock bits can be read using the Get Lock Bit command (GLB). The n^{th} lock bit is active when the bit n of the bit mask is set..

Table 20-10. Get Lock Bit Command

Step	Handshake Sequence	MODE[3:0]	DATA[15:0]
1	Write handshaking	CMDE	GLB
2	Read handshaking	DATA	Lock Bit Mask Status 0 = Lock bit is cleared 1 = Lock bit is set

20.2.5.5 Flash General-purpose NVM Commands

General-purpose NVM bits (GP NVM bits) can be set using the Set GPNVM command (SGPB). This command also activates GP NVM bits. A bit mask is provided as argument to the command. When bit 0 of the bit mask is set, then the first GP NVM bit is activated.

In the same way, the Clear GPNVM command (CGPB) is used to clear general-purpose NVM bits. The general-purpose NVM bit is deactivated when the corresponding bit in the pattern value is set to 1.

Table 20-11. Set/Clear GP NVM Command

Step	Handshake Sequence	MODE[3:0]	DATA[15:0]
1	Write handshaking	CMDE	SGPB or CGPB
2	Write handshaking	DATA	GP NVM bit pattern value

General-purpose NVM bits can be read using the Get GPNVM Bit command (GGPB). The n^{th} GP NVM bit is active when bit n of the bit mask is set..

Table 20-12. Get GP NVM Bit Command

Step	Handshake Sequence	MODE[3:0]	DATA[15:0]
1	Write handshaking	CMDE	GGPB
2	Read handshaking	DATA	GP NVM Bit Mask Status 0 = GP NVM bit is cleared 1 = GP NVM bit is set

20.2.5.6 Flash Security Bit Command

A security bit can be set using the Set Security Bit command (SSE). Once the security bit is active, the Fast Flash programming is disabled. No other command can be run. An event on the Erase pin can erase the security bit once the contents of the Flash have been erased.

Table 20-13. Set Security Bit Command

Step	Handshake Sequence	MODE[3:0]	DATA[15:0]
1	Write handshaking	CMDE	SSE
2	Write handshaking	DATA	0

Once the security bit is set, it is not possible to access FFPI. The only way to erase the security bit is to erase the Flash.

In order to erase the Flash, the user must perform the following:

- Power-off the chip
- Power-on the chip with TST = 0
- Assert Erase during a period of more than 220 ms
- Power-off the chip

Then it is possible to return to FFPI mode and check that Flash is erased.

20.2.5.7 Memory Write Command

This command is used to perform a write access to any memory location.

The Memory Write command (WRAM) is optimized for consecutive writes. Write handshaking can be chained; an internal address buffer is automatically increased.

Table 20-14. Write Command

Step	Handshake Sequence	MODE[3:0]	DATA[15:0]
1	Write handshaking	CMDE	WRAM
2	Write handshaking	ADDR0	Memory Address LSB
3	Write handshaking	ADDR1	Memory Address
4	Write handshaking	DATA	*Memory Address++
5	Write handshaking	DATA	*Memory Address++
...
n	Write handshaking	ADDR0	Memory Address LSB
n+1	Write handshaking	ADDR1	Memory Address
n+2	Write handshaking	DATA	*Memory Address++
n+3	Write handshaking	DATA	*Memory Address++
...

20.2.5.8 Get Version Command

The Get Version (GVE) command retrieves the version of the FFPI interface.

Table 20-15. Get Version Command

Step	Handshake Sequence	MODE[3:0]	DATA[15:0]
1	Write handshaking	CMDE	GVE
2	Write handshaking	DATA	Version

21. Cortex M Cache Controller (CMCC) (ONLY FOR SAM4SD32/SD16/SA16)

21.1 Description

The Cortex M Cache Controller (CMCC) is a 4-Way set associative unified cache controller. It integrates a controller, tag directory, data memory, metadata memory and a configuration interface.

21.2 Embedded Characteristics

- Physically addressed and physically tagged
- L1 data cache set to 2 Kbytes
- L1 cache line size set to 16 Bytes
- L1 cache integrates 32 bus master interface
- Unified Direct mapped cache architecture
- Unified 4-Way set associative cache architecture
- Write through cache operations, read allocate
- Round Robin victim selection policy
- Event Monitoring, with one programmable 32-bit counter
- Configuration registers accessible through Cortex M Private Peripheral Bus
- Cache Interface includes cache maintenance operations registers

21.3 Block Diagram

Figure 21-1. Block Diagram

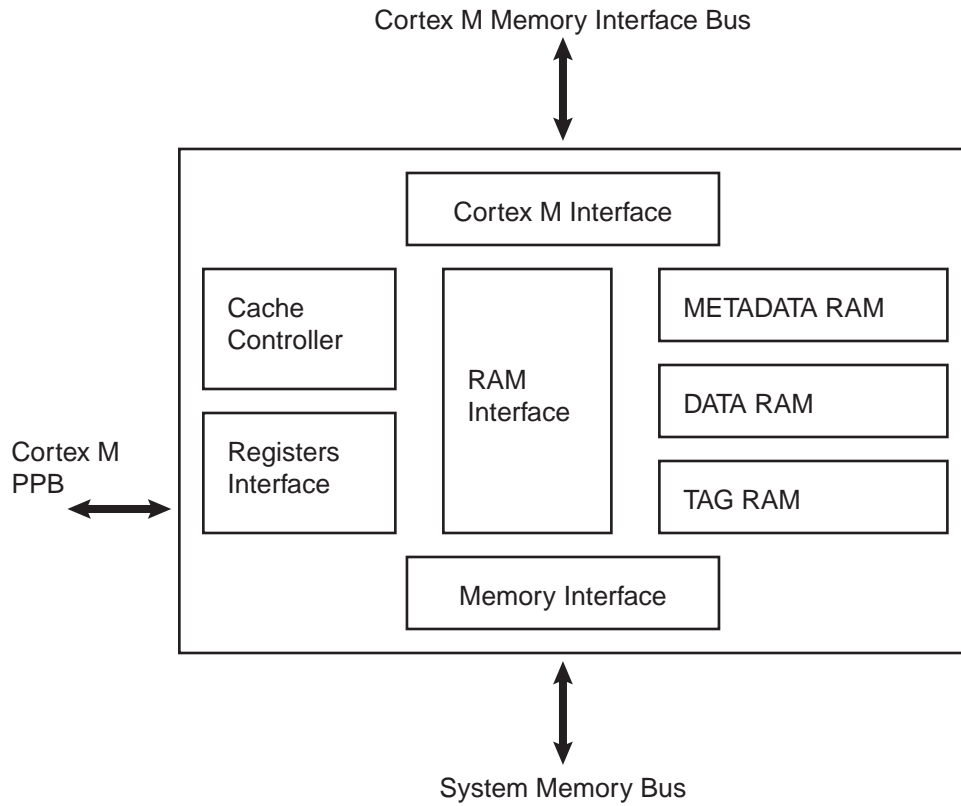

21.4 Functional Description

21.4.1 Cache Operation

On reset, the cache controller data entries are all invalidated and the cache is disabled. The cache is transparent to processor operations. The cache controller is activated through the use of its configuration registers. The configuration interface is memory mapped in the private peripheral bus.

Use the following sequence to enable the cache controller.

1. Verify that the cache controller is disabled, reading the value of the CSTS (cache status) field of the CMCC_SR register.
2. Enable the cache controller, writing one to CEN (cache enable) field of the CMCC_CTRL register.

21.4.2 Cache Maintenance

If the contents seen by the cache has changed, the user needs to invalidate the cache entries. It can be done line by line or for all cache entries.

21.4.2.1 Cache Invalidate by Line Operation

When an invalidate by line command is issued the cache controller resets the valid bit information of the decoded cache line. As the line is no longer valid the replacement counter points to that line.

Use the following sequence to invalidate one line of cache.

1. Disable the cache controller, writing 0 to the CEN field of the CMCC_CTRL register.
2. Check CSTS field of the CMCC_SR to verify that the cache is successfully disabled.
3. Perform an invalidate by line writing the bit set {index, way} in the CMCC_MAINT1 register.
4. Enable the cache controller, writing 1 to the CEN field of the CMCC_CTRL register.

21.4.2.2 Cache Invalidate All Operation

To invalidate all cache entries:

Write 1 to the INVALL field of the CMCC_MAINT0 register.

21.4.3 Cache Performance Monitoring

The Cortex M cache controller includes a programmable 32-bit monitor counter. The monitor can be configured to count the number of clock cycles, the number of data hits or the number of instruction hits.

Use the following sequence to activate the counter

1. Configure the monitor counter, writing the MODE field of the CMCC_CFG register.
2. Enable the counter, writing one to the MENABLE field of the CMCC_MEN register.
3. If required, reset the counter, writing one to the SWRST field of the CMCC_MCTRL register.
4. Check the value of the monitor counter, reading EVENT_CNT field of the CMCC_SR.

21.5 Cortex M Cache Controller (CMCC) User Interface

Table 21-1. Register Mapping

Offset	Register	Name	Access	Reset
0x00	Cache Type Register	CMCC_TYPE	Read-only	–
0x04	Cache Configuration Register	CMCC_CFG	Read-write	0x00000000
0x08	Cache Control Register	CMCC_CTRL	Write-only	0x00000000
0x0C	Cache Status Register	CMCC_SR	Read-only	0x00000000
0x10 - 0x1C	Reserved	–	–	–
0x20	Cache Maintenance Register 0	CMCC_MAINT0	Write-only	–
0x24	Cache Maintenance Register 1	CMCC_MAINT1	Write-only	–
0x28	Cache Monitor Configuration Register	CMCC_MCFG	Read-write	0x00000000
0x2C	Cache Monitor Enable Register	CMCC_MEN	Read-write	0x00000000
0x30	Cache Monitor Control Register	CMCC_MCTRL	Write-only	–
0x34	Cache Monitor Status Register	CMCC_MSR	Read-only	0x00000000
0xXX - 0xFC	Reserved	–	–	–

21.5.1 Cache Controller Type Register

Name: CMCC_TYPE

Address: 0x4007C000

Access: Read-only

31	30	29	28	27	26	25	24
–	–	–	–	–	–	–	–
23	22	21	20	19	18	17	16
–	–	–	–	–	–	–	–
15	14	13	12	11	10	9	8
–		CLSIZE			CSIZE		
7	6	5	4	3	2	1	0
LCKDOWN	WAYNUM		RRP	LRUP	RANDP	GCLK	AP

- **AP: Access Port Access Allowed**

0: Access Port Access is disabled.

1: Access Port Access is enabled.

- **GCLK: Dynamic Clock Gating Supported**

0: Cache controller does not support clock gating.

1: Cache controller uses dynamic clock gating.

- **RANDP: Random Selection Policy Supported**

0: Random victim selection is not supported.

1: Random victim selection is supported.

- **LRUP: Least Recently Used Policy Supported**

0: Least Recently Used Policy is not supported.

1: Least Recently Used Policy is supported.

- **RRP: Random Selection Policy Supported**

0: Random Selection Policy is not supported.

1: Random Selection Policy is supported.

- **WAYNUM: Number of Way**

Value	Name	Description
0	DMAPPED	Direct Mapped Cache
1	ARCH2WAY	2-WAY set associative
2	ARCH4WAY	4-WAY set associative
3	ARCH8WAY	8-WAY set associative

- **LCKDOWN: Lock Down Supported**

0: Lock Down is not supported.

1: Lock Down is supported.

- **CSIZE: Cache Size**

Value	Name	Description
0	CSIZE_1KB	Cache Size 1 KBytes
1	CSIZE_2KB	Cache Size 2 KBytes
2	CSIZE_4KB	Cache Size 4 KBytes
3	CSIZE_8KB	Cache Size 8 KBytes

- **CLSIZE: Cache Size**

Value	Name	Description
0	CLSIZE_1KB	4 bytes
1	CLSIZE_2KB	8 bytes
2	CLSIZE_4KB	16 bytes
3	CLSIZE_8KB	32 bytes

21.5.2 Cache Controller Configuration Register

Name: CMCC_CFG

Address: 0x4007C004

Access: Read-write

31	30	29	28	27	26	25	24
–	–	–	–	–	–	–	–
23	22	21	20	19	18	17	16
–	–	–	–	–	–	–	–
15	14	13	12	11	10	9	8
–	–	–	–	–	–	–	–
7	6	5	4	3	2	1	0
–	–	–	–	–	–	–	GCLKDIS

- **GCLKDIS: Disable Clock Gating**

0: Clock gating is activated.

1: Clock gating is disabled.

21.5.3 Cache Controller Control Register

Name: CMCC_CTRL

Address: 0x4007C008

Access: Write-only

31	30	29	28	27	26	25	24
–	–	–	–	–	–	–	–
23	22	21	20	19	18	17	16
–	–	–	–	–	–	–	–
15	14	13	12	11	10	9	8
–	–	–	–	–	–	–	–
7	6	5	4	3	2	1	0
–	–	–	–	–	–	–	CEN

- **CEN: Cache Controller Enable**

0: When set to 0 this field disables the cache controller.

1: When set to 1 this field enables the cache controller.

21.5.4 Cache Controller Status Register

Name: CMCC_SR

Address: 0x4007C00C

Access: Write-only

31	30	29	28	27	26	25	24
–	–	–	–	–	–	–	–
23	22	21	20	19	18	17	16
–	–	–	–	–	–	–	–
15	14	13	12	11	10	9	8
–	–	–	–	–	–	–	–
7	6	5	4	3	2	1	0
–	–	–	–	–	–	–	CSTS

- **CSTS: Cache Controller Status**

0: When read as 0, this field indicates that the cache controller is disabled.

1: When read as 1, this field indicates that the cache controller is enabled.

21.5.5 Cache Controller Maintenance Register 0

Name: CMCC_MAINT0

Address: 0x4007C020

Access: Write-only

31	30	29	28	27	26	25	24
–	–	–	–	–	–	–	–
23	22	21	20	19	18	17	16
–	–	–	–	–	–	–	–
15	14	13	12	11	10	9	8
–	–	–	–	–	–	–	–
7	6	5	4	3	2	1	0
–	–	–	–	–	–	–	INVALL

- **INVALL: Cache Controller Invalidate All**

0: No effect.

1: When set to one, this field invalidates all cache entries.

21.5.6 Cache Controller Maintenance Register 1

Name: CMCC_MAINT1

Address: 0x4007C024

Access: Write-only

31	30	29	28	27	26	25	24
WAY		–	–	–	–	–	–
23	22	21	20	19	18	17	16
–	–	–	–	–	–	–	–
15	14	13	12	11	10	9	8
–	–	–	–	–	–	–	–
7	6	5	4	3	2	1	0
INDEX				–	–	–	–

- **INDEX: Invalidate Index**

This field indicates the cache line that is being invalidated.

- **WAY: Invalidate Way**

Value	Name	Description
0	WAY0	Way 0 is selection for index invalidation
1	WAY1	Way 1 is selection for index invalidation
2	WAY2	Way 2 is selection for index invalidation
3	WAY3	Way 3 is selection for index invalidation

21.5.7 Cache Controller Monitor Configuration Register

Name: CMCC_MCFG

Address: 0x4007C028

Access: Write-only

31	30	29	28	27	26	25	24
–	–	–	–	–	–	–	–
23	22	21	20	19	18	17	16
–	–	–	–	–	–	–	–
15	14	13	12	11	10	9	8
–	–	–	–	–	–	–	–
7	6	5	4	3	2	1	0
–	–	–	–	–	–	MODE	

- **MODE: Cache Controller Monitor Counter Mode**

Value	Name	Description
0	CYCLE_COUNT	cycle counter
1	IHIT_COUNT	instruction hit counter
2	DHIT_COUNT	data hit counter

21.5.8 Cache Controller Monitor Enable Register

Name: CMCC_MEN

Address: 0x4007C02C

Access: Write-only

Reset: 0x00002000

31	30	29	28	27	26	25	24
-	-	-	-	-	-	-	-
23	22	21	20	19	18	17	16
-	-	-	-	-	-	-	-
15	14	13	12	11	10	9	8
-	-	-	-	-	-	-	-
7	6	5	4	3	2	1	0
-	-	-	-	-	-	-	MENABLE

- **MENABLE: Cache Controller Monitor Enable**

0: When set to 0, the monitor counter is disabled.

1: When set to 1, the monitor counter is activated.

21.5.9 Cache Controller Monitor Control Register

Name: CMCC_MCTRL

Address: 0x4007C030

Access: Write-only

Reset: 0x00002000

31	30	29	28	27	26	25	24
–	–	–	–	–	–	–	–
23	22	21	20	19	18	17	16
–	–	–	–	–	–	–	–
15	14	13	12	11	10	9	8
–	–	–	–	–	–	–	–
7	6	5	4	3	2	1	0
–	–	–	–	–	–	–	SWRST

- **SWRST: Monitor**

0: No effect.

1: When set to 1 this field resets the event counter register.



21.5.10 Cache Controller Monitor Status Register

Name: CMCC_MSR

Address: 0x4007C034

Access: Write-only

Reset: 0x00002000

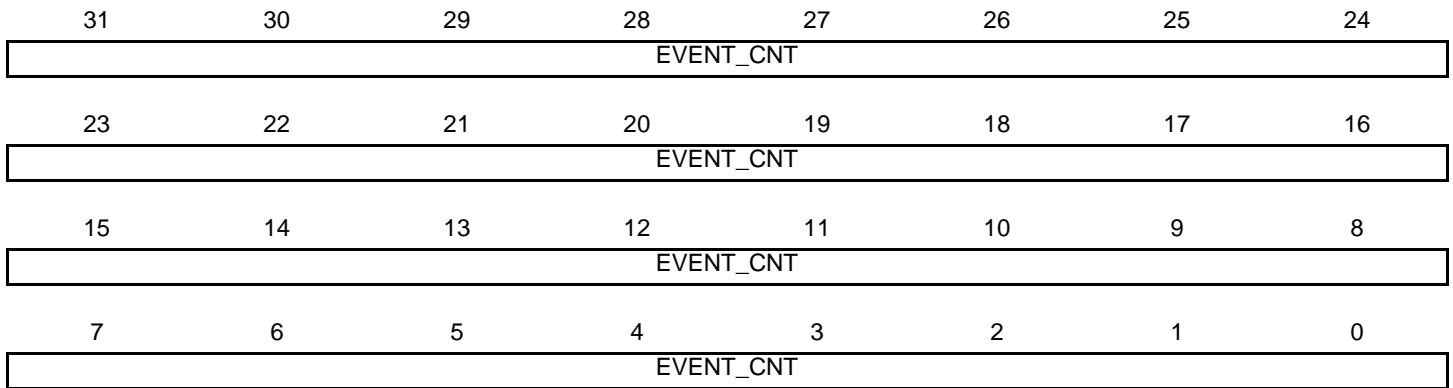

- **EVENT_CNT: Monitor Event Counter**



22. Cyclic Redundancy Check Calculation Unit (CRCCU)

22.1 Description

The Cyclic Redundancy Check Calculation Unit (CRCCU) has its own DMA which functions as a Master with the Bus Matrix.

22.2 Embedded Characteristics

- 32-bit cyclic redundancy check automatic calculation
- CRC calculation between two addresses of the memory

22.3 CRCCU Block Diagram

Figure 22-1. Block Diagram

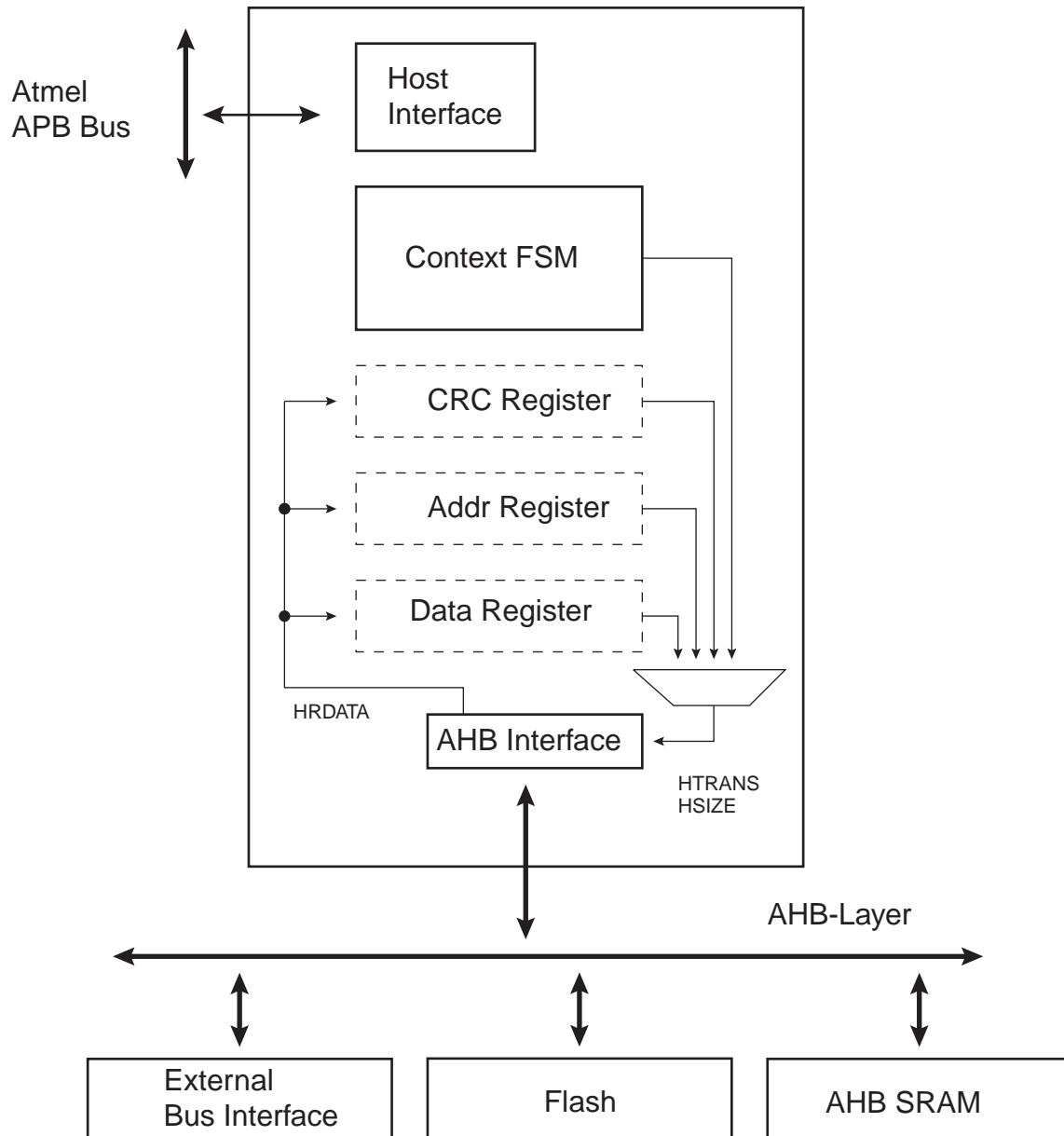

22.4 Product Dependencies

22.4.1 Power Management

The CRCCU is clocked through the Power Management Controller (PMC), the programmer must first configure the CRCCU in the PMC to enable the CRCCU clock.

22.4.2 Interrupt Source

The CRCCU has an interrupt line connected to the Interrupt Controller. Handling the CRCCU interrupt requires programming the Interrupt Controller before configuring the CRCCU.

22.5 CRCCU Functional Description

22.5.1 CRC Calculation Unit description

The CRCCU integrates a dedicated Cyclic Redundancy Check (CRC) engine. When configured and activated, this CRC engine performs a checksum computation on a Memory Area. CRC computation is performed from the LSB to MSB bit. Three different polynomials are available CCITT802.3, CASTAGNOLI and CCITT16, see the bitfield description, “[PTYPE: Primitive Polynomial](#)” on page 387, for details.

22.5.2 CRC Calculation Unit Operation

The CRCCU has a DMA controller that supports programmable CRC memory checks. When enabled, the DMA channel reads a programmable amount of data and computes CRC on the fly.

The CRCCU is controlled by two registers, TR_ADDR and TR_CTRL which need to be mapped in the internal SRAM. The addresses of these two registers are pointed at by the CRCCU_DSCR register.

Table 22-1. CRCCU Descriptor Memory Mapping

CRCCU Address		SRAM Memory
CRCCU_DSCR+0x0	---->	TR_ADDR
CRCCU_DSCR+0x4	---->	TR_CTRL
CRCCU_DSCR+0x8	---->	Reserved
CRCCU_DSCR+0xC	---->	Reserved
CRCCU_DSCR+0x10	---->	TR_CRC

TR_ADDR defines the start address of memory area targeted for CRC calculation.

TR_CTRL defines the buffer transfer size, the transfer width (byte, halfword, word) and the transfer-completed interrupt enable.

To start the CRCCU, the user needs to set the CRC enable bit (ENABLE) in the CRCCU Mode Register (CRCCU_MR), then configure it and finally set the DMA enable bit (DMAEN) in the CRCCU DMA Enable Register (CRCCU_DMA_EN).

When the CRCCU is enabled, the CRCCU reads the predefined amount of data (defined in TR_CTRL) located at TR_ADDR start address and computes the checksum.

The CRCCU_SR register contains the temporary CRC value.

The BTSIZE field located in the TR_CTRL register (located in memory), is automatically decremented if its value is different from zero. Once the value of the BTSIZE field is equal to zero, the CRCCU is disabled by hardware. In this case, the relevant CRCCU DMA Status Register bit, DMASR, is automatically cleared.

If the COMPARE field of the CRCCU_MR register is set to true, the TR_CRC (Transfer Reference Register) is compared with the last CRC computed. If a mismatch occurs, an error flag is set and an interrupt is raised (if unmasked).

The CRCCU accesses the memory by single access (TRWIDTH size) in order not to limit the bandwidth usage of the system, but the DIVIDER field of the CRCCU Mode Register can be used to lower it by dividing the frequency of the single accesses.

In order to compute the CRC for a memory size larger than 256 Kbytes or for non-contiguous memory area, it is possible to re-enable the CRCCU on the new memory area and the CRC will be updated accordingly. Use the RESET field of the CRCCU_CR register to reset the CRCCU Status Register to its default value (0xFFFF_FFFF).

22.6 Transfer Control Registers Memory Mapping

Table 22-2. Transfer Control Register Memory Mapping

Offset	Register	Name	Access
CRCCU_DSCR + 0x0	CRCCU Transfer Address Register	TR_ADDR	Read-write
CRCCU_DSCR + 0x4	CRCCU Transfer Control Register	TR_CTRL	Read-write
CRCCU_DSCR + 0xC - 0x10	Reserved		
CRCCU_DSCR+0x10	CRCCU Transfer Reference Register	TR_CRC	Read-write

Note: These Registers are memory mapped.



22.6.1 Transfer Address Register

Name: TR_ADDR

Access: Read-write

Reset: 0x00000000

31	30	29	28	27	26	25	24
ADDR							
23	22	21	20	19	18	17	16
ADDR							
15	14	13	12	11	10	9	8
ADDR							
7	6	5	4	3	2	1	0
ADDR							

- ADDR: Transfer Address



22.6.2 Transfer Control Register

Name: TR_CTRL

Access: Read-write

Reset: 0x00000000

31	30	29	28	27	26	25	24
–	–	–	–	IEN	–	TRWIDTH	
23	22	21	20	19	18	17	16
–	–	–	–	–	–	–	–
15	14	13	12	11	10	9	8
BTSIZE							
7	6	5	4	3	2	1	0
BTSIZE							

- **BTSIZE:** Buffer Transfer Size
- **TRWIDTH:** Transfer Width Register

TRWIDTH	Single Transfer Size
00	BYTE
01	HALFWORD
10	WORD

- **IEN: Context Done Interrupt Enable**

When set to zero, the transfer done status bit is set at the end of the transfer.

22.6.3 Transfer Reference Register

Name: TR_CRC

Access: Read-write

Reset: 0x00000000

31	30	29	28	27	26	25	24
REFCRC							
23	22	21	20	19	18	17	16
REFCRC							
15	14	13	12	11	10	9	8
REFCRC							
7	6	5	4	3	2	1	0
REFCRC							

- **REFCRC: Reference CRC**

When Compare mode is enabled, the checksum is compared with that register.

22.7 Cyclic Redundancy Check Calculation Unit (CRCCU) User Interface

Table 22-3. Register Mapping

Offset	Register	Name	Access	Reset
0x00000000	CRCCU Descriptor Base Register	CRCCU_DSCR	Read-write	0x00000000
0x00000004	Reserved			
0x00000008	CRCCU DMA Enable Register	CRCCU_DMA_EN	Write-only	0x00000000
0x0000000C	CRCCU DMA Disable Register	CRCCU_DMA_DIS	Write-only	0x00000000
0x00000010	CRCCU DMA Status Register	CRCCU_DMA_SR	Read-only	0x00000000
0x00000014	CRCCU DMA Interrupt Enable Register	CRCCU_DMA_IER	Write-only	0x00000000
0x00000018	CRCCU DMA Interrupt Disable Register	CRCCU_DMA_IDR	Write-only	0x00000000
0x0000001C	CRCCU DMA Interrupt Mask Register	CRCCU_DMA_IMR	Read-only	0x00000000
0x00000020	CRCCU DMA Interrupt Status Register	CRCCU_DMA_ISR	Read-only	0x00000000
0x0024-0x0030	Reserved			
0x00000034	CRCCU Control Register	CRCCU_CR	Write-only	0x00000000
0x00000038	CRCCU Mode Register	CRCCU_MR	Read-write	0x00000000
0x0000003C	CRCCU Status Register	CRCCU_SR	Read-only	0xFFFFFFFF
0x00000040	CRCCU Interrupt Enable Register	CRCCU_IER	Write-only	0x00000000
0x00000044	CRCCU Interrupt Disable Register	CRCCU_IDR	Write-only	0x00000000
0x00000048	CRCCU Interrupt Mask Register	CRCCU_IMR	Read-only	0x00000000
0x0000004C	CRCCU Interrupt Status Register	CRCCU_ISR	Read-only	0x00000000

22.7.1 CRCCU Descriptor Base Address Register

Name: CRCCU_DSCR

Address: 0x40044000

Access: Read-write

Reset: 0x00000000

31	30	29	28	27	26	25	24
DSCR							
23	22	21	20	19	18	17	16
DSCR							
15	14	13	12	11	10	9	8
DSCR							-
7	6	5	4	3	2	1	0
-	-	-	-	-	-	-	-

- **DSCR: Descriptor Base Address**

DSCR needs to be aligned with 512-byte boundaries.

22.7.2 CRCCU DMA Enable Register

Name: CRCCU_DMA_EN

Address: 0x40044008

Access: Write-only

Reset: 0x00000000

31	30	29	28	27	26	25	24
–	–	–	–	–	–	–	–
23	22	21	20	19	18	17	16
–	–	–	–	–	–	–	–
15	14	13	12	11	10	9	8
–	–	–	–	–	–	–	–
7	6	5	4	3	2	1	0
–	–	–	–	–	–	–	DMAEN

- **DMAEN: DMA Enable Register**

Write one to enable the CRCCU DMA channel.

22.7.3 CRCCU DMA Disable Register

Name: CRCCU_DMA_DIS

Address: 0x4004400C

Access: Write-only

Reset: 0x00000000

31	30	29	28	27	26	25	24
–	–	–	–	–	–	–	–
23	22	21	20	19	18	17	16
–	–	–	–	–	–	–	–
15	14	13	12	11	10	9	8
–	–	–	–	–	–	–	–
7	6	5	4	3	2	1	0
–	–	–	–	–	–	–	DMADIS

- **DMADIS: DMA Disable Register**

Write one to disable the DMA channel

22.7.4 CRCCU DMA Status Register

Name: CRCCU_DMA_SR

Address: 0x40044010

Access: Read-only

Reset: 0x00000000

31	30	29	28	27	26	25	24
–	–	–	–	–	–	–	–
23	22	21	20	19	18	17	16
–	–	–	–	–	–	–	–
15	14	13	12	11	10	9	8
–	–	–	–	–	–	–	–
7	6	5	4	3	2	1	0
–	–	–	–	–	–	–	DMASR

- **DMASR: DMA Status Register**

When set to one, this bit indicates that DMA Channel is enabled.

22.7.5 CRCCU DMA Interrupt Enable Register

Name: CRCCU_DMA_IER

Address: 0x40044014

Access: Write-only

Reset: 0x00000000

31	30	29	28	27	26	25	24
–	–	–	–	–	–	–	–
23	22	21	20	19	18	17	16
–	–	–	–	–	–	–	–
15	14	13	12	11	10	9	8
–	–	–	–	–	–	–	–
7	6	5	4	3	2	1	0
–	–	–	–	–	–	–	DMAIER

- **DMAIER: Interrupt Enable register**

Set bit to one to enable the interrupt.

22.7.6 CRCCU DMA Interrupt Disable Register

Name: CRCCU_DMA_IDR

Address: 0x40044018

Access: Write-only

Reset: 0x00000000

31	30	29	28	27	26	25	24
–	–	–	–	–	–	–	–
23	22	21	20	19	18	17	16
–	–	–	–	–	–	–	–
15	14	13	12	11	10	9	8
–	–	–	–	–	–	–	–
7	6	5	4	3	2	1	0
–	–	–	–	–	–	–	DMAIDR

- **DMAIDR: Interrupt Disable register**

Set to one to disable the interrupt.

22.7.7 CRCCU DMA Interrupt Mask Register

Name: CRCCU_DMA_IMR

Address: 0x4004401C

Access: Write-only

Reset: 0x00000000

31	30	29	28	27	26	25	24
–	–	–	–	–	–	–	–
23	22	21	20	19	18	17	16
–	–	–	–	–	–	–	–
15	14	13	12	11	10	9	8
–	–	–	–	–	–	–	–
7	6	5	4	3	2	1	0
–	–	–	–	–	–	–	DMAIMR

- **DMAIMR: Interrupt Mask Register**

0: Buffer Transfer Completed interrupt is disabled.

1: Buffer Transfer Completed interrupt is enabled.

22.7.8 CRCCU DMA Interrupt Status Register

Name: CRCCU_DMA_ISR

Address: 0x40044020

Access: Read-only

Reset: 0x00000000

31	30	29	28	27	26	25	24
–	–	–	–	–	–	–	–
23	22	21	20	19	18	17	16
–	–	–	–	–	–	–	–
15	14	13	12	11	10	9	8
–	–	–	–	–	–	–	–
7	6	5	4	3	2	1	0
–	–	–	–	–	–	–	DMAISR

- **DMAISR: Interrupt Status register**

When DMAISR is set, DMA buffer transfer has terminated. This flag is reset after read.

22.7.9 CRCCU Control Register

Name: CRCCU_CR

Address: 0x40044034

Access: Write-only

Reset: 0x00000000

31	30	29	28	27	26	25	24
–	–	–	–	–	–	–	–
23	22	21	20	19	18	17	16
–	–	–	–	–	–	–	–
15	14	13	12	11	10	9	8
–	–	–	–	–	–	–	–
7	6	5	4	3	2	1	0
–	–	–	–	–	–	–	RESET

- **RESET: CRC Computation Reset**

When set to one, this bit resets the CRCCU_SR register to 0xFFFF FFFF.

22.7.10 CRCCU Mode Register

Name: CRCCU_MR

Address: 0x40044038

Access: Read Write

Reset: 0x00000000

31	30	29	28	27	26	25	24
–	–	–	–	–	–	–	–
23	22	21	20	19	18	17	16
–	–	–	–	–	–	–	–
15	14	13	12	11	10	9	8
–	–	–	–	–	–	–	–
7	6	5	4	3	2	1	0
DIVIDER				PTYPE		COMPARE	ENABLE

- **ENABLE: CRC Enable**

- **COMPARE: CRC Compare**

If set to one, this bit indicates that the CRCCU DMA will compare the CRC computed on the data stream with the value stored.

in the TR_CRC reference register. If a mismatch occurs, the ERRISR bit in the CRCCU_ISR register is set.

- **PTYPE: Primitive Polynomial**

Value	Name	Description
0	CCITT8023	Polynom 0x04C11DB7
1	CASTAGNOLI	Polynom 0x1EDC6F41
2	CCITT16	Polynom 0x1021

- **DIVIDER: Request Divider**

CRCCU DMA performs successive transfers. It is possible to reduce the bandwidth drained by the CRCCU DMA by programming the DIVIDER field. The transfer request frequency is divided by $2^{(DIVIDER+1)}$.

22.7.11 CRCCU Status Register

Name: CRCCU_SR

Address: 0x4004403C

Access: Read-only

Reset: 0x00000000

31	30	29	28	27	26	25	24
CRC							
23	22	21	20	19	18	17	16
CRC							
15	14	13	12	11	10	9	8
CRC							
7	6	5	4	3	2	1	0
CRC							

- **CRC: Cyclic Redundancy Check Value**

This register can not be read if the COMPARE field of the CRC_MR register is set to true.

22.7.12 CRCCU Interrupt Enable Register

Name: CRCCU_IER

Address: 0x40044040

Access: Write-only

Reset: 0x00000000

31	30	29	28	27	26	25	24
–	–	–	–	–	–	–	–
23	22	21	20	19	18	17	16
–	–	–	–	–	–	–	–
15	14	13	12	11	10	9	8
–	–	–	–	–	–	–	–
7	6	5	4	3	2	1	0
–	–	–	–	–	–	–	ERRIER

- **ERRIER: CRC Error Interrupt Enable**

22.7.13 CRCCU Interrupt Disable Register

Name: CRCCU_IDR

Address: 0x40044044

Access: Write-only

Reset: 0x00000000

31	30	29	28	27	26	25	24
–	–	–	–	–	–	–	–
23	22	21	20	19	18	17	16
–	–	–	–	–	–	–	–
15	14	13	12	11	10	9	8
–	–	–	–	–	–	–	–
7	6	5	4	3	2	1	0
–	–	–	–	–	–	–	ERRIDR

- **ERRIDR: CRC Error Interrupt Disable**

22.7.14 CRCCU Interrupt Mask Register

Name: CRCCU_IMR

Address: 0x40044048

Access: Write-only

Reset: 0x00000000

31	30	29	28	27	26	25	24
–	–	–	–	–	–	–	–
23	22	21	20	19	18	17	16
–	–	–	–	–	–	–	–
15	14	13	12	11	10	9	8
–	–	–	–	–	–	–	–
7	6	5	4	3	2	1	0
–	–	–	–	–	–	–	ERRIMR

- **ERRIMR: CRC Error Interrupt Mask**

22.7.15 CRCCU Interrupt Status Register

Name: CRCCU_ISR

Address: 0x4004404C

Access: Read-only

Reset: 0x00000000

31	30	29	28	27	26	25	24
–	–	–	–	–	–	–	–
23	22	21	20	19	18	17	16
–	–	–	–	–	–	–	–
15	14	13	12	11	10	9	8
–	–	–	–	–	–	–	–
7	6	5	4	3	2	1	0
–	–	–	–	–	–	–	ERRISR

- **ERRISR: CRC Error Interrupt Status**

23. SAM4S Boot Program

23.1 Description

The SAM-BA Boot Program integrates an array of programs permitting download and/or upload into the different memories of the product.

23.2 Hardware and Software Constraints

- SAM-BA Boot uses the first 2048 bytes of the SRAM for variables and stacks. The remaining available size can be used for user's code.
- USB Requirements:
 - External Crystal or External Clock⁽¹⁾ with frequency of:
 - 11,289 MHz
 - 12,000 MHz
 - 16,000 MHz
 - 18,432 MHz
- UART0 requirements: None

Note: 1. Must be 2500 ppm and 1.2V Square Wave Signal.

Table 23-1. Pins Driven during Boot Program Execution

Peripheral	Pin	PIO Line
UART0	URXD0	PA9
UART0	UTXD0	PA10

23.3 Flow Diagram

The Boot Program implements the algorithm in [Figure 23-1](#).

Figure 23-1. Boot Program Algorithm Flow Diagram

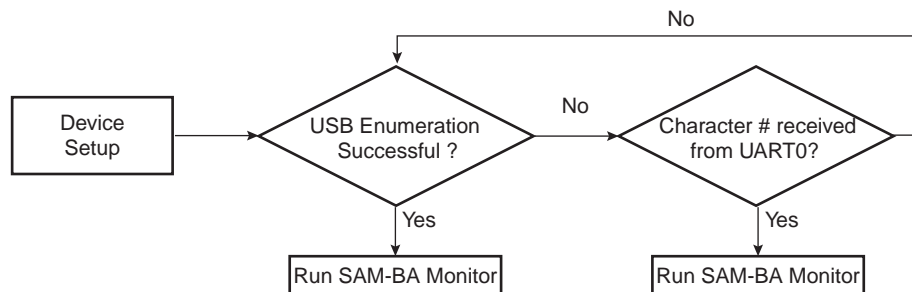

The SAM-BA Boot program seeks to detect a source clock either from the embedded main oscillator with external crystal (main oscillator enabled) or from a supported frequency signal applied to the XIN pin (Main oscillator in bypass mode).

If a clock is found from the two possible sources above, the boot program checks to verify that the frequency is one of the supported external frequencies. If the frequency is one of the supported external frequencies, USB activation is allowed, else (no clock or frequency other than one of the supported external frequencies), the internal 12 MHz RC oscillator is used as main clock and USB clock is not allowed due to frequency drift of the 12 MHz RC oscillator.

23.4 Device Initialization

Initialization follows the steps described below:

1. Stack setup
2. Setup the Embedded Flash Controller
3. External Clock detection (crystal or external clock on XIN)
4. If external crystal or clock with supported frequency, allow USB activation
5. Else, does not allow USB activation and use internal 12 MHz RC oscillator
6. Main oscillator frequency detection if no external clock detected
7. Switch Master Clock on Main Oscillator
8. C variable initialization
9. PLLA setup: PLLA is initialized to generate a 48 MHz clock
10. Disable the Watchdog
11. Initialization of UART0 (115200 bauds, 8, N, 1)
12. Initialization of the USB Device Port (in case USB activation allowed)
13. Wait for one of the following events
 - a. Check if USB device enumeration has occurred
 - b. Check if characters have been received in UART0
14. Jump to SAM-BA Monitor (see [Section 23.5 "SAM-BA Monitor"](#))

23.5 SAM-BA Monitor

The SAM-BA boot principle:

Once the communication interface is identified, to run in an infinite loop waiting for different commands as shown in [Table 23-2](#).

Table 23-2. Commands Available through the SAM-BA Boot

Command	Action	Argument(s)	Example
N	Set Normal Mode	No argument	N#
T	Set Terminal Mode	No argument	T#
O	Write a Byte	Address, Value#	O 200001,CA#
o	Read a Byte	Address,#	o 200001,#
H	Write a Half Word	Address, Value#	H 200002,CAFE#
h	Read a Half Word	Address,#	h 200002,#
W	Write a Word	Address, Value#	W 200000,CAFEDCA#
w	Read a Word	Address,#	w 200000,#
S	Send a File	Address,#	S 200000,#
R	Receive a File	Address, NbOfBytes#	R 200000,1234#
G	Go	Address#	G 200200#
V	Display Version	No argument	V#

- Mode commands:
 - Normal mode configures SAM-BA Monitor to send/receive data in binary format,
 - Terminal mode configures SAM-BA Monitor to send/receive data in ascii format.
- Write commands: Write a byte (**O**), a halfword (**H**) or a word (**W**) to the target.
 - *Address*: Address in hexadecimal.
 - *Value*: Byte, halfword or word to write in hexadecimal.
 - *Output*: '>'.
- Read commands: Read a byte (**o**), a halfword (**h**) or a word (**w**) from the target.
 - *Address*: Address in hexadecimal
 - *Output*: The byte, halfword or word read in hexadecimal following by '>'
- Send a file (**S**): Send a file to a specified address
 - *Address*: Address in hexadecimal
 - *Output*: '>'.

Note: There is a time-out on this command which is reached when the prompt '>' appears before the end of the command execution.

- Receive a file (**R**): Receive data into a file from a specified address
 - *Address*: Address in hexadecimal
 - *NbOfBytes*: Number of bytes in hexadecimal to receive
 - *Output*: '>'

- Go (**G**): Jump to a specified address and execute the code
 - Address: Address to jump in hexadecimal
 - Output: '>'
- Get Version (**V**): Return the SAM-BA boot version
 - Output: '>'

23.5.1 UART0 Serial Port

Communication is performed through the UART0 initialized to 115200 Baud, 8, n, 1.

The Send and Receive File commands use the Xmodem protocol to communicate. Any terminal performing this protocol can be used to send the application file to the target. The size of the binary file to send depends on the SRAM size embedded in the product. In all cases, the size of the binary file must be lower than the SRAM size because the Xmodem protocol requires some SRAM memory to work. See, [Section 23.2 "Hardware and Software Constraints"](#)

23.5.2 Xmodem Protocol

The Xmodem protocol supported is the 128-byte length block. This protocol uses a two-character CRC-16 to guarantee detection of a maximum bit error.

Xmodem protocol with CRC is accurate provided both sender and receiver report successful transmission. Each block of the transfer looks like:

<SOH><blk #><255-blk #><--128 data bytes--><checksum> in which:

- <SOH> = 01 hex
- <blk #> = binary number, starts at 01, increments by 1, and wraps 0FFH to 00H (not to 01)
- <255-blk #> = 1's complement of the blk#.
- <checksum> = 2 bytes CRC16

[Figure 23-2](#) shows a transmission using this protocol.

Figure 23-2. Xmodem Transfer Example

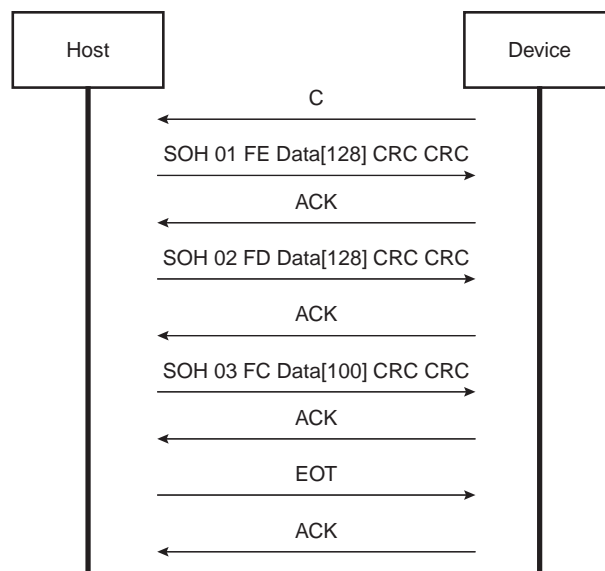

23.5.3 USB Device Port

The device uses the USB communication device class (CDC) drivers to take advantage of the installed PC RS-232 software to talk over the USB. The CDC class is implemented in all releases of Windows®, from Windows 98SE to Windows XP. The CDC document, available at www.usb.org, describes a way to implement devices such as ISDN modems and virtual COM ports.

The Vendor ID (VID) is Atmel's vendor ID 0x03EB. The product ID (PID) is 0x6124. These references are used by the host operating system to mount the correct driver. On Windows systems, the INF files contain the correspondence between vendor ID and product ID.

For More details about VID/PID for End Product/Systems, please refer to the Vendor ID form available from the USB Implementers Forum:

http://www.usb.org/developers/vendor/VID_Only_Form_withCCAuth_102407b.pdf

"Unauthorized use of assigned or unassigned USB Vendor ID Numbers and associated Product ID Numbers is strictly prohibited."

Atmel provides an INF example to see the device as a new serial port and also provides another custom driver used by the SAM-BA application: atm6124.sys. Refer to the document "USB Basic Application", literature number 6123, for more details.

23.5.3.1 Enumeration Process

The USB protocol is a master/slave protocol. This is the host that starts the enumeration sending requests to the device through the control endpoint. The device handles standard requests as defined in the USB Specification.

Table 23-3. Handled Standard Requests

Request	Definition
GET_DESCRIPTOR	Returns the current device configuration value.
SET_ADDRESS	Sets the device address for all future device access.
SET_CONFIGURATION	Sets the device configuration.
GET_CONFIGURATION	Returns the current device configuration value.
GET_STATUS	Returns status for the specified recipient.
SET_FEATURE	Set or Enable a specific feature.
CLEAR_FEATURE	Clear or Disable a specific feature.

The device also handles some class requests defined in the CDC class.

Table 23-4. Handled Class Requests

Request	Definition
SET_LINE_CODING	Configures DTE rate, stop bits, parity and number of character bits.
GET_LINE_CODING	Requests current DTE rate, stop bits, parity and number of character bits.
SET_CONTROL_LINE_STATE	RS-232 signal used to tell the DCE device the DTE device is now present.

Unhandled requests are STALLED.

23.5.3.2 Communication Endpoints

There are two communication endpoints and endpoint 0 is used for the enumeration process. Endpoint 1 is a 64-byte Bulk OUT endpoint and endpoint 2 is a 64-byte Bulk IN endpoint. SAM-BA Boot commands are sent by the host through endpoint 1. If required, the message is split by the host into several data payloads by the host driver.

If the command requires a response, the host can send IN transactions to pick up the response.

23.5.4 In Application Programming (IAP) Feature

The IAP feature is a function located in ROM that can be called by any software application.

When called, this function sends the desired FLASH command to the EEFC and waits for the Flash to be ready (looping while the FRDY bit is not set in the MC_FSR register).

Since this function is executed from ROM, this allows Flash programming (such as sector write) to be done by code running in Flash.

The IAP function entry point is retrieved by reading the NMI vector in ROM (0x00800008).

This function takes one argument in parameter: the command to be sent to the EEFC.

This function returns the value of the MC_FSR register.

IAP software code example:

```
(unsigned int) (*IAP_Function)(unsigned long);
void main (void){

    unsigned long FlashSectorNum = 200; //
    unsigned long flash_cmd = 0;
    unsigned long flash_status = 0;
    unsigned long EFCIndex = 0; // 0:EEFC0, 1: EEFC1

    /* Initialize the function pointer (retrieve function address from NMI
    vector) */

    IAP_Function = ((unsigned long) (*)(unsigned long)) 0x00800008;

    /* Send your data to the sector here */

    /* build the command to send to EEFC */

    flash_cmd = (0x5A << 24) | (FlashSectorNum << 8) | AT91C_MC_FCMD_EWP;

    /* Call the IAP function with appropriate command */

    flash_status = IAP_Function (EFCIndex, flash_cmd);

}
```

24. Bus Matrix (MATRIX)

24.1 Description

The Bus Matrix (MATRIX) implements a multi-layer AHB that enables parallel access paths between multiple AHB masters and slaves in a system, which increases the overall bandwidth. Bus Matrix interconnects 4 AHB Masters to 5 AHB Slaves. The normal latency to connect a master to a slave is one cycle except for the default master of the accessed slave which is connected directly (zero cycle latency).

The Bus Matrix user interface also provides a Chip Configuration User Interface with Registers that allow to support application specific features.

24.2 Embedded Characteristics

24.2.1 Matrix Masters

The Bus Matrix manages 4 masters, which means that each master can perform an access concurrently with others, to an available slave.

Each master has its own decoder, which is defined specifically for each master. In order to simplify the addressing, all the masters have the same decodings.

Table 24-1. List of Bus Matrix Masters

Master 0	Cortex-M4 Instruction/Data
Master 1	Cortex-M4 System
Master 2	Peripheral DMA Controller (PDC)
Master 3	CRC Calculation Unit

24.2.2 Matrix Slaves

The Bus Matrix manages 5 slaves. Each slave has its own arbiter, allowing a different arbitration per slave.

Table 24-2. List of Bus Matrix Slaves

Slave 0	Internal SRAM
Slave 1	Internal ROM
Slave 2	Internal Flash
Slave 3	External Bus Interface
Slave 4	Peripheral Bridge

24.2.3 Master to Slave Access

All the Masters can normally access all the Slaves. However, some paths do not make sense, for example allowing access from the Cortex-M4 S Bus to the Internal ROM. Thus, these paths are forbidden or simply not wired, and shown as “-” in the following table

Table 24-3. Master to Slave Access

Slaves	Masters	0	1	2	3
		Cortex-M4 I/D Bus	Cortex-M4 S Bus	PDC	CRCCU
0	Internal SRAM	-	X	X	X
1	Internal ROM	X	-	X	X
2	Internal Flash	X	-	-	X
3	External Bus Interface	-	X	X	X
4	Peripheral Bridge	-	X	X	-

24.3 Memory Mapping

Bus Matrix provides one decoder for every AHB Master Interface. The decoder offers each AHB Master several memory mappings. In fact, depending on the product, each memory area may be assigned to several slaves. Booting at the same address while using different AHB slaves (i.e. internal ROM or internal Flash) becomes possible.

24.4 Special Bus Granting Techniques

The Bus Matrix provides some speculative bus granting techniques in order to anticipate access requests from some masters. This mechanism allows to reduce latency at first accesses of a burst or single transfer. The bus granting mechanism allows to set a default master for every slave.

At the end of the current access, if no other request is pending, the slave remains connected to its associated default master. A slave can be associated with three kinds of default masters: no default master, last access master and fixed default master.

24.4.1 No Default Master

At the end of the current access, if no other request is pending, the slave is disconnected from all masters. No Default Master suits low power mode.

24.4.2 Last Access Master

At the end of the current access, if no other request is pending, the slave remains connected to the last master that performed an access request.

24.4.3 Fixed Default Master

At the end of the current access, if no other request is pending, the slave connects to its fixed default master. Unlike last access master, the fixed master doesn't change unless the user modifies it by a software action (field `FIXED_DEFMSTR` of the related `MATRIX_SCFG`).

To change from one kind of default master to another, the Bus Matrix user interface provides the Slave Configuration Registers, one for each slave, that allow to set a default master for each slave. The Slave Configuration Register contains two fields:

DEFMSTR_TYPE and FIXED_DEFMSTR. The 2-bit DEFMSTR_TYPE field allows to choose the default master type (no default, last access master, fixed default master) whereas the 4-bit FIXED_DEFMSTR field allows to choose a fixed default master provided that DEFMSTR_TYPE is set to fixed default master. Please refer to the Bus Matrix user interface description.

24.5 Arbitration

The Bus Matrix provides an arbitration mechanism that allows to reduce latency when conflict cases occur, basically when two or more masters try to access the same slave at the same time. One arbiter per AHB slave is provided, allowing to arbitrate each slave differently.

The Bus Matrix provides to the user the possibility to choose between 2 arbitration types, and this for each slave:

1. Round-Robin Arbitration (the default)
2. Fixed Priority Arbitration

This choice is given through the field ARBT of the Slave Configuration Registers (MATRIX_SCFG).

Each algorithm may be complemented by selecting a default master configuration for each slave.

When a re-arbitration has to be done, it is realized only under some specific conditions detailed in the following paragraph.

24.5.1 Arbitration Rules

Each arbiter has the ability to arbitrate between two or more different master's requests. In order to avoid burst breaking and also to provide the maximum throughput for slave interfaces, arbitration may only take place during the following cycles:

1. Idle Cycles: when a slave is not connected to any master or is connected to a master which is not currently accessing it.
2. Single Cycles: when a slave is currently doing a single access.
3. End of Burst Cycles: when the current cycle is the last cycle of a burst transfer. For defined length burst, predicted end of burst matches the size of the transfer but is managed differently for undefined length burst (See [Section 24.5.1.1 "Undefined Length Burst Arbitration" on page 401](#)).
4. Slot Cycle Limit: when the slot cycle counter has reached the limit value indicating that the current master access is too long and must be broken (See [Section 24.5.1.2 "Slot Cycle Limit Arbitration" on page 402](#)).

24.5.1.1 Undefined Length Burst Arbitration

In order to avoid too long slave handling during undefined length bursts (INCR), the Bus Matrix provides specific logic in order to re-arbitrate before the end of the INCR transfer.

A predicted end of burst is used for defined length burst transfer, which is selected between the following:

1. Infinite: no predicted end of burst is generated and therefore INCR burst transfer will never be broken.
2. Four beat bursts: predicted end of burst is generated at the end of each four beat boundary inside INCR transfer.
3. Eight beat bursts: predicted end of burst is generated at the end of each eight beat boundary inside INCR transfer.
4. Sixteen beat bursts: predicted end of burst is generated at the end of each sixteen beat boundary inside INCR transfer.

This selection can be done through the field ULBT of the Master Configuration Registers (MATRIX_MCFG).

24.5.1.2 Slot Cycle Limit Arbitration

The Bus Matrix contains specific logic to break too long accesses such as very long bursts on a very slow slave (e.g. an external low speed memory). At the beginning of the burst access, a counter is loaded with the value previously written in the SLOT_CYCLE field of the related Slave Configuration Register (MATRIX_SCFG) and decreased at each clock cycle. When the counter reaches zero, the arbiter has the ability to re-arbitrate at the end of the current byte, half word or word transfer.

24.5.2 Round-Robin Arbitration

This algorithm allows the Bus Matrix arbiters to dispatch the requests from different masters to the same slave in a round-robin manner. If two or more master's requests arise at the same time, the master with the lowest number is first serviced then the others are serviced in a round-robin manner.

There are three round-robin algorithm implemented:

- Round-Robin arbitration without default master
- Round-Robin arbitration with last access master
- Round-Robin arbitration with fixed default master

24.5.2.1 Round-Robin arbitration without default master

This is the main algorithm used by Bus Matrix arbiters. It allows the Bus Matrix to dispatch requests from different masters to the same slave in a pure round-robin manner. At the end of the current access, if no other request is pending, the slave is disconnected from all masters. This configuration incurs one latency cycle for the first access of a burst. Arbitration without default master can be used for masters that perform significant bursts.

24.5.2.2 Round-Robin arbitration with last access master

This is a biased round-robin algorithm used by Bus Matrix arbiters. It allows the Bus Matrix to remove the one latency cycle for the last master that accessed the slave. In fact, at the end of the current transfer, if no other master request is pending, the slave remains connected to the last master that performs the access. Other non privileged masters will still get one latency cycle if they want to access the same slave. This technique can be used for masters that mainly perform single accesses.

24.5.2.3 Round-Robin arbitration with fixed default master

This is another biased round-robin algorithm, it allows the Bus Matrix arbiters to remove the one latency cycle for the fixed default master per slave. At the end of the current access, the slave remains connected to its fixed default master. Every request attempted by this fixed default master will not cause any latency whereas other non privileged masters will still get one latency cycle. This technique can be used for masters that mainly perform single accesses.

24.5.3 Fixed Priority Arbitration

This algorithm allows the Bus Matrix arbiters to dispatch the requests from different masters to the same slave by using the fixed priority defined by the user. If two or more master's requests are active at the same time, the master with the highest priority number is serviced first. If two or more master's requests with the same priority are active at the same time, the master with the highest number is serviced first.

For each slave, the priority of each master may be defined through the Priority Registers for Slaves (MATRIX_PRAS and MATRIX_PRBS).

24.6 System I/O Configuration

The System I/O Configuration register (CCFG_SYSIO) allows to configure some I/O lines in System I/O mode (such as JTAG, ERASE, USB, etc...) or as general purpose I/O lines. Enabling or disabling the corresponding I/O lines in peripheral mode or in PIO mode (PIO_PER or PIO_PDR registers) in the PIO controller as no effect. However, the direction (input or output), pull-up, pull-down and other mode control is still managed by the PIO controller.

24.7 Write Protect Registers

To prevent any single software error that may corrupt MATRIX behavior, **the entire MATRIX address space from address offset 0x000 to 0x1FC can be write-protected** by setting the WPEN bit in the MATRIX Write Protect Mode Register (MATRIX_WPMR).

If a write access to anywhere in the MATRIX address space from address offset 0x000 to 0x1FC is detected, then the WPVS flag in the MATRIX Write Protect Status Register (MATRIX_WPSR) is set and the field WPVSR indicates in which register the write access has been attempted.

The WPVS flag is reset by writing the MATRIX Write Protect Mode Register (MATRIX_WPMR) with the appropriate access key WPKEY.

24.8 Bus Matrix (MATRIX) User Interface

Table 24-4. Register Mapping

Offset	Register	Name	Access	Reset
0x0000	Master Configuration Register 0	MATRIX_MCFG0	Read-write	0x00000000
0x0004	Master Configuration Register 1	MATRIX_MCFG1	Read-write	0x00000000
0x0008	Master Configuration Register 2	MATRIX_MCFG2	Read-write	0x00000000
0x000C	Master Configuration Register 3	MATRIX_MCFG3	Read-write	0x00000000
0x0010 - 0x003C	Reserved	–	–	–
0x0040	Slave Configuration Register 0	MATRIX_SCFG0	Read-write	0x00010010
0x0044	Slave Configuration Register 1	MATRIX_SCFG1	Read-write	0x00050010
0x0048	Slave Configuration Register 2	MATRIX_SCFG2	Read-write	0x00000010
0x004C	Slave Configuration Register 3	MATRIX_SCFG3	Read-write	0x00000010
0x0050	Slave Configuration Register 4	MATRIX_SCFG4	Read-write	0x00000010
0x0054 - 0x007C	Reserved	–	–	–
0x0080	Priority Register A for Slave 0	MATRIX_PRAS0	Read-write	0x00000000
0x0084	Reserved	–	–	–
0x0088	Priority Register A for Slave 1	MATRIX_PRAS1	Read-write	0x00000000
0x008C	Reserved	–	–	–
0x0090	Priority Register A for Slave 2	MATRIX_PRAS2	Read-write	0x00000000
0x0094	Reserved	–	–	–
0x0098	Priority Register A for Slave 3	MATRIX_PRAS3	Read-write	0x00000000
0x009C	Reserved	–	–	–
0x00A0	Priority Register A for Slave 4	MATRIX_PRAS4	Read-write	0x00000000
0x00A4 - 0x0110	Reserved	–	–	–
0x0114	System I/O Configuration register	CCFG_SYSIO	Read/Write	0x00000000
0x0118	Reserved	–	–	–
0x011C	SMC Chip Select NAND Flash Assignment Register	CCFG_SMCNFCS	Read/Write	0x00000000
0x0120 - 0x010C	Reserved	–	–	–
0x1E4	Write Protect Mode Register	MATRIX_WPMR	Read-write	0x0
0x1E8	Write Protect Status Register	MATRIX_WPSR	Read-only	0x0
0x0110 - 0x01FC	Reserved	–	–	–

24.8.1 Bus Matrix Master Configuration Registers

Name: MATRIX_MCFG0..MATRIX_MCFG3

Address: 0x400E0200

Access: Read-write

31	30	29	28	27	26	25	24
-	-	-	-	-	-	-	-
23	22	21	20	19	18	17	16
-	-	-	-	-	-	-	-
15	14	13	12	11	10	9	8
-	-	-	-	-	-	-	-
7	6	5	4	3	2	1	0
-	-	-	-	-	ULBT		

- **ULBT: Undefined Length Burst Type**

0: Infinite Length Burst

No predicted end of burst is generated and therefore INCR bursts coming from this master cannot be broken.

1: Single Access

The undefined length burst is treated as a succession of single access allowing re arbitration at each beat of the INCR burst.

2: Four Beat Burst

The undefined length burst is split into a 4-beat bursts allowing re arbitration at each 4-beat burst end.

3: Eight Beat Burst

The undefined length burst is split into 8-beat bursts allowing re arbitration at each 8-beat burst end.

4: Sixteen Beat Burst

The undefined length burst is split into 16-beat bursts allowing re arbitration at each 16-beat burst end.

24.8.2 Bus Matrix Slave Configuration Registers

Name: MATRIX_SCFG0..MATRIX_SCFG4

Address: 0x400E0240

Access: Read-write

31	30	29	28	27	26	25	24
-	-	-	-	-	-	ARBT	
23	22	21	20	19	18	17	16
-	-	-	FIXED_DEFMSTR			DEFMSTR_TYPE	
15	14	13	12	11	10	9	8
-	-	-	-	-	-	-	-
7	6	5	4	3	2	1	0
SLOT_CYCLE							

- **SLOT_CYCLE: Maximum Number of Allowed Cycles for a Burst**

When the SLOT_CYCLE limit is reached for a burst it may be broken by another master trying to access this slave.

This limit has been placed to avoid locking very slow slaves when very long bursts are used.

This limit should not be very small though. An unreasonable small value will break every burst and the Bus Matrix will spend its time to arbitrate without performing any data transfer. 16 cycles is a reasonable value for SLOT_CYCLE.

- **DEFMSTR_TYPE: Default Master Type**

0: No Default Master

At the end of current slave access, if no other master request is pending, the slave is disconnected from all masters.

This results in having a one cycle latency for the first access of a burst transfer or for a single access.

1: Last Default Master

At the end of current slave access, if no other master request is pending, the slave stays connected to the last master having accessed it.

This results in not having the one cycle latency when the last master re-tries access on the slave again.

2: Fixed Default Master

At the end of the current slave access, if no other master request is pending, the slave connects to the fixed master the number that has been written in the FIXED_DEFMSTR field.

This results in not having the one cycle latency when the fixed master re-tries access on the slave again.

- **FIXED_DEFMSTR: Fixed Default Master**

This is the number of the Default Master for this slave. Only used if DEFMSTR_TYPE is 2. Specifying the number of a master which is not connected to the selected slave is equivalent to setting DEFMSTR_TYPE to 0.

- **ARBT: Arbitration Type**

0: Round-Robin Arbitration

1: Fixed Priority Arbitration

2: Reserved

3: Reserved

24.8.3 Bus Matrix Priority Registers For Slaves

Name: MATRIX_PRAS0..MATRIX_PRAS4

Address: 0x400E0280 [0], 0x400E0288 [1], 0x400E0290 [2], 0x400E0298 [3], 0x400E02A0 [4]

Access: Read-write

31	30	29	28	27	26	25	24
-	-	-	-	-	-	-	-
23	22	21	20	19	18	17	16
-	-	-	-	-	-	M4PR	
15	14	13	12	11	10	9	8
-	-	M3PR		-	-	M2PR	
7	6	5	4	3	2	1	0
-	-	M1PR		-	-	M0PR	

- **MxPR: Master x Priority**

Fixed priority of Master x for accessing the selected slave. The higher the number, the higher the priority.

24.8.4 System I/O Configuration Register

Name: CCFG_SYSIO

Address: 0x400E0314

Access: Read-write

Reset: 0x0000_0000

31	30	29	28	27	26	25	24
-	-	-	-	-	-	-	-
23	22	21	20	19	18	17	16
-	-	-	-	-	-	-	-
15	14	13	12	11	10	9	8
-	-	-	SYSIO12	SYSIO11	SYSIO10	-	-
7	6	5	4	3	2	1	0
SYSIO7	SYSIO6	SYSIO5	SYSIO4	-	-	-	-

- **SYSIO4: PB4 or TDI Assignment**

0 = TDI function selected.

1 = PB4 function selected.

- **SYSIO5: PB5 or TDO/TRACESWO Assignment**

0 = TDO/TRACESWO function selected.

1 = PB5 function selected.

- **SYSIO6: PB6 or TMS/SWDIO Assignment**

0 = TMS/SWDIO function selected.

1 = PB6 function selected.

- **SYSIO7: PB7 or TCK/SWCLK Assignment**

0 = TCK/SWCLK function selected.

1 = PB7 function selected.

- **SYSIO10: PB10 or DDM Assignment**

0 = DDM function selected.

1 = PB10 function selected.

- **SYSIO11: PB11 or DDP Assignment**

0 = DDP function selected.

1 = PB11 function selected.

- **SYSIO12: PB12 or ERASE Assignment**

0 = ERASE function selected.

1 = PB12 function selected.

24.8.5 SMC NAND Flash Chip select Configuration Register

Name: CCFG_SMCNFCS

Address: 0x400E031C

Type: Read-write

Reset: 0x0000_0000

31	30	29	28	27	26	25	24
-	-	-	-	-	-	-	-
23	22	21	20	19	18	17	16
-	-	-	-	-	-	-	-
15	14	13	12	11	10	9	8
-	-	-	-	-	-	-	-
7	6	5	4	3	2	1	0
-	-	-	-	SMC_NFCS3	SMC_NFCS2	SMC_NFCS1	SMC_NFCS0

- **SMC_NFCS0: SMC NAND Flash Chip Select 0 Assignment**

0 = NCS0 is not assigned to a NAND Flash (NANDOE and NANWE not used for NCS0)

1 = NCS0 is assigned to a NAND Flash (NANDOE and NANWE used for NCS0)

- **SMC_NFCS1: SMC NAND Flash Chip Select 1 Assignment**

0 = NCS1 is not assigned to a NAND Flash (NANDOE and NANWE not used for NCS1)

1 = NCS1 is assigned to a NAND Flash (NANDOE and NANWE used for NCS1)

- **SMC_NFCS2: SMC NAND Flash Chip Select 2 Assignment**

0 = NCS2 is not assigned to a NAND Flash (NANDOE and NANWE not used for NCS2)

1 = NCS2 is assigned to a NAND Flash (NANDOE and NANWE used for NCS2)

- **SMC_NFCS3: SMC NAND Flash Chip Select 3 Assignment**

0 = NCS3 is not assigned to a NAND Flash (NANDOE and NANWE not used for NCS3)

1 = NCS3 is assigned to a NAND Flash (NANDOE and NANWE used for NCS3)



24.8.6 Write Protect Mode Register

Name: MATRIX_WPMR

Address: 0x400E03E4

Access: Read-write

31	30	29	28	27	26	25	24
WPKEY							
23	22	21	20	19	18	17	16
WPKEY							
15	14	13	12	11	10	9	8
WPKEY							
7	6	5	4	3	2	1	0
-	-	-	-	-	-	-	WPEN

For more details on MATRIX_WPMR, refer to [Section 24.7 “Write Protect Registers” on page 403](#).

• **WPEN: Write Protect ENable**

0 = Disables the Write Protect if WPKEY corresponds to 0x4D4154 (“MAT” in ASCII).

1 = Enables the Write Protect if WPKEY corresponds to 0x4D4154 (“MAT” in ASCII).

Protects the entire MATRIX address space from address offset 0x000 to 0x1FC.

• **WPKEY: Write Protect KEY** (Write-only)

Should be written at value 0x4D4154 (“MAT” in ASCII). Writing any other value in this field aborts the write operation of the WPEN bit. Always reads as 0.

24.8.7 Write Protect Status Register

Name: MATRIX_WPSR

Address: 0x400E03E8

Access: Read-only

31	30	29	28	27	26	25	24
–	–	–	–	–	–	–	–
23	22	21	20	19	18	17	16
WPVSR							
15	14	13	12	11	10	9	8
WPVSR							
7	6	5	4	3	2	1	0
–	–	–	–	–	–	–	WPVS

For more details on MATRIX_WPSR, refer to [Section 24.7 “Write Protect Registers” on page 403](#).

- **WPVS: Write Protect Violation Status**

0: No Write Protect Violation has occurred since the last write of MATRIX_WPMR.

1: At least one Write Protect Violation has occurred since the last write of MATRIX_WPMR.

- **WPVSR: Write Protect Violation Source**

Should be written at value 0x4D4154 (“MAT” in ASCII). Writing any other value in this field aborts the write operation of the WPEN bit. Always reads as 0.



25. Static Memory Controller (SMC)

25.1 Description

The External Bus Interface is designed to ensure the successful data transfer between several external devices and the Cortex-M4 based device. The External Bus Interface of the SAM4S consists of a Static Memory Controller (SMC).

This SMC is capable of handling several types of external memory and peripheral devices, such as SRAM, PSRAM, PROM, EPROM, EEPROM, LCD Module, NOR Flash and NAND Flash.

The Static Memory Controller (SMC) generates the signals that control the access to the external memory devices or peripheral devices. It has 4 Chip Selects, a 24-bit address bus, and an 8-bit data bus. Separate read and write control signals allow for direct memory and peripheral interfacing. Read and write signal waveforms are fully adjustable.

The SMC can manage wait requests from external devices to extend the current access. The SMC is provided with an automatic slow clock mode. In slow clock mode, it switches from user-programmed waveforms to slow-rate specific waveforms on read and write signals. The SMC supports asynchronous burst read in page mode access for page size up to 32 bytes.

The External Data Bus can be scrambled/unscrambled by means of user keys.

25.2 Embedded Characteristics

- 16-Mbyte Address Space per Chip Select
- 8-bit Data Bus
- Word, Halfword, Byte Transfers
- Byte Write or Byte Select Lines
- Programmable Setup, Pulse And Hold Time for Read Signals per Chip Select
- Programmable Setup, Pulse And Hold Time for Write Signals per Chip Select
- Programmable Data Float Time per Chip Select
- Compliant with LCD Module
- External Wait Request
- Automatic Switch to Slow Clock Mode
- Asynchronous Read in Page Mode Supported: Page Size Ranges from 4 to 32 Bytes
- NAND Flash additional logic supporting NAND Flash with Multiplexed Data/Address buses
- Hardware Configurable number of chip select from 1 to 4
- Programmable timing on a per chip select basis

25.3 I/O Lines Description

Table 25-1. I/O Line Description

Name	Description	Type	Active Level
NCS[3:0]	Static Memory Controller Chip Select Lines	Output	Low
NRD	Read Signal	Output	Low
NWE	Write Enable Signal	Output	Low
A[23:0]	Address Bus	Output	
D[7:0]	Data Bus	I/O	
NWAIT	External Wait Signal	Input	Low
NANDCS	NAND Flash Chip Select Line	Output	Low
NANDOE	NAND Flash Output Enable	Output	Low
NANDWE	NAND Flash Write Enable	Output	Low

25.4 Product Dependencies

25.4.1 I/O Lines

The pins used for interfacing the Static Memory Controller are multiplexed with the PIO lines. The programmer must first program the PIO controller to assign the Static Memory Controller pins to their peripheral function. If I/O Lines of the SMC are not used by the application, they can be used for other purposes by the PIO Controller.

25.4.2 Power Management

The SMC is clocked through the Power Management Controller (PMC), thus the programmer must first configure the PMC to enable the SMC clock.

25.5 External Memory Mapping

The SMC provides up to 24 address lines, A[23:0]. This allows each chip select line to address up to 16 Mbytes of memory.

If the physical memory device connected on one chip select is smaller than 16 Mbytes, it wraps around and appears to be repeated within this space. The SMC correctly handles any valid access to the memory device within the page (see [Figure 25-1](#)).

Figure 25-1. Memory Connections for Four External Devices

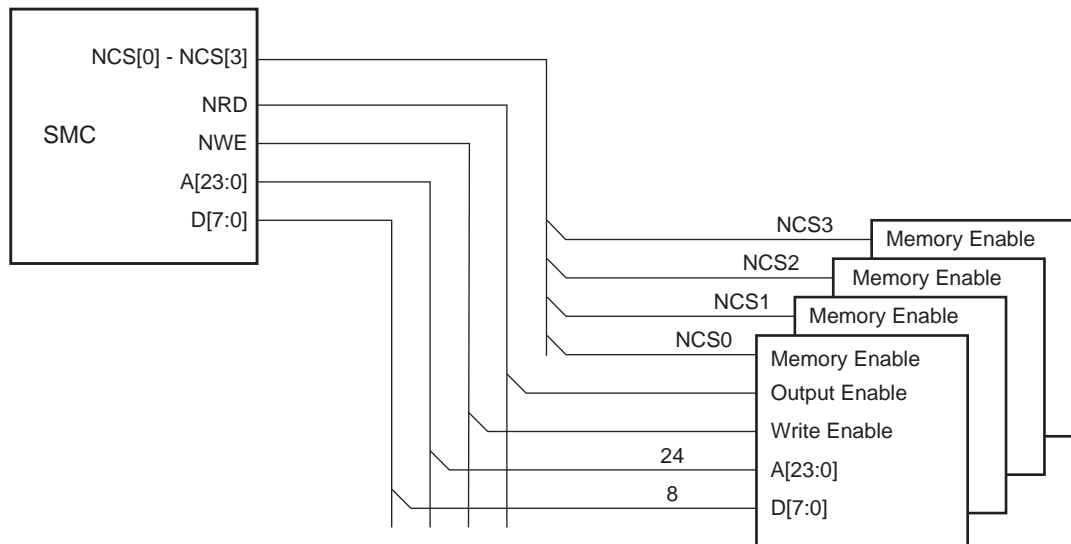

25.6 Connection to External Devices

25.6.1 Data Bus Width

The data bus width is 8 bits.

Figure 25-2 shows how to connect a 512K x 8-bit memory on NCS2.

Figure 25-2. Memory Connection for an 8-bit Data Bus

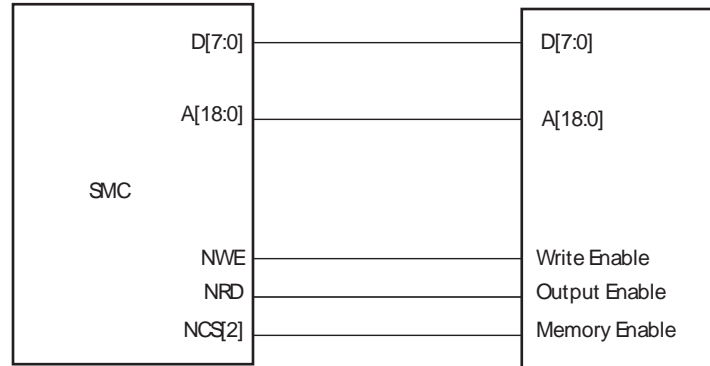

25.6.1.1 NAND Flash Support

The SMC integrates circuitry that interfaces to NAND Flash devices.

The NAND Flash logic is driven by the Static Memory Controller. It depends on the programming of the SMC_NFCSx field in the CCFG_SMCNFCS Register on the Bus Matrix User Interface. For details on this register, refer to the Bus Matrix User Interface section. Access to an external NAND Flash device via the address space reserved to the chip select programmed.

The user can connect up to 4 NAND Flash devices with separated chip select.

The NAND Flash logic drives the read and write command signals of the SMC on the NANDOE and NANDWE signals when the NCSx programmed is active. NANDOE and NANDWE are disabled as soon as the transfer address fails to lie in the NCSx programmed address space.

Figure 25-3. NAND Flash Signal Multiplexing on SMC Pins

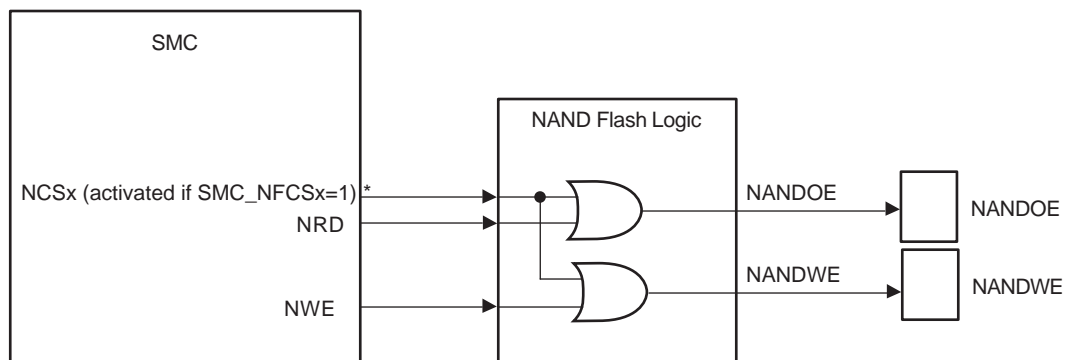

* in CCFG_SMCNFCS Matrix register

Note that when NAND Flash logic is activated, (SMCNFCSx=1), NWE pin cannot be used i PIO Mode but only in peripheral mode (NWE function). If NWE function is not used for other external memories (SRAM, LCD), it must be configured in one of the following modes.

- PIO Input with pull-up enabled (default state after reset)
- PIO Output set at level 1

The address latch enable and command latch enable signals on the NAND Flash device are driven by address bits A22 and A21 of the address bus. Any bit of the address bus can also be used for this purpose. The command, address or data words on the data bus of the NAND Flash device use their own addresses within the NCSx address space (configured by CCFG_SMCNFCS Register on the Bus Matrix User Interface). The chip enable (CE) signal of the device and the ready/busy (R/B) signals are connected to PIO lines. The CE signal then remains asserted even when NCS3 is not selected, preventing the device from returning to standby mode. The NANDCS output signal should be used in accordance with the external NAND Flash device type.

Two types of CE behavior exist depending on the NAND flash device:

- Standard NAND Flash devices require that the CE pin remains asserted Low continuously during the read busy period to prevent the device from returning to standby mode. Since the Static Memory Controller (SMC) asserts the NCSx signal High, it is necessary to connect the CE pin of the NAND Flash device to a GPIO line, in order to hold it low during the busy period preceding data read out.
- This restriction has been removed for “CE don’t care” NAND Flash devices. The NCSx signal can be directly connected to the CE pin of the NAND Flash device.

[Figure 25-4](#) illustrates both topologies: Standard and “CE don’t care” NAND Flash.

Figure 25-4. Standard and “CE don’t care” NAND Flash Application Examples

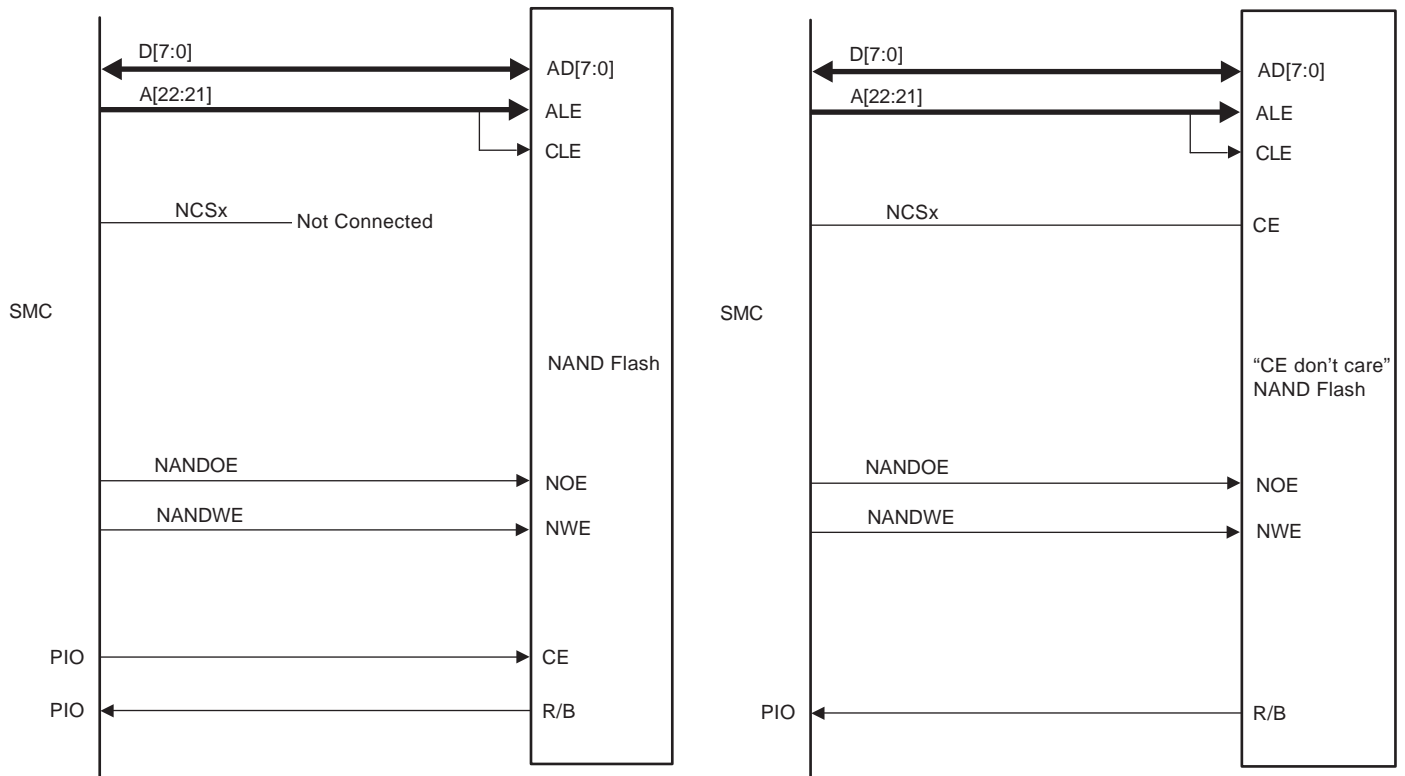

25.7 Application Example

25.7.1 Implementation Examples

Hardware configurations are given for illustration only. The user should refer to the manufacturer web site to check for memory device availability.

For hardware implementation examples, refer to SAM4S-EK schematics, which show examples of a connection to an LCD module and NAND Flash.

25.7.1.1 8-bit NAND Flash

Hardware Configuration

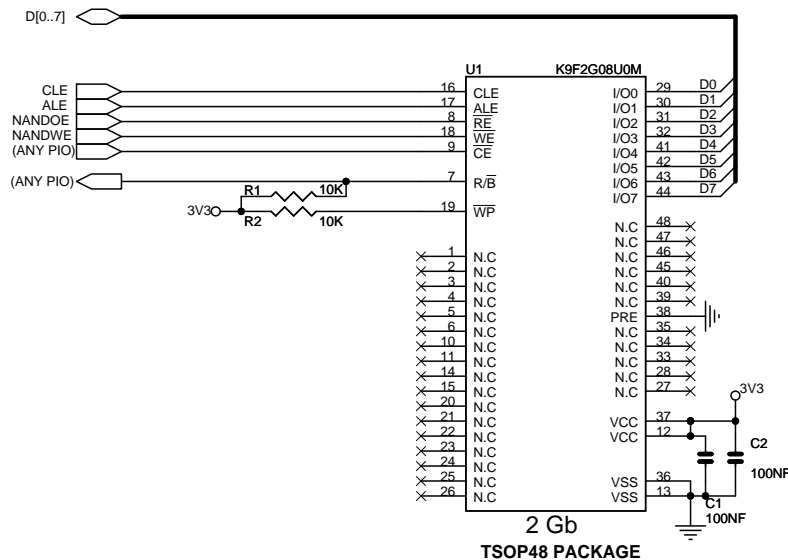

Software Configuration

Perform the following configuration:

- Assign the SMC_NFCSx (for example SMC_NFCS3) field in the CCFG_SMCNFCS Register on the Bus Matrix User Interface.
- Reserve A21 / A22 for ALE / CLE functions. Address and Command Latches are controlled respectively by setting to 1 the address bits A21 and A22 during accesses.
- NANDOE and NANDWE signals are multiplexed with PIO lines. Thus, the dedicated PIOs must be programmed in peripheral mode in the PIO controller.
- Configure a PIO line as an input to manage the Ready/Busy signal.
- Configure Static Memory Controller CS3 Setup, Pulse, Cycle and Mode according to NAND Flash timings, the data bus width and the system bus frequency.

In this example, the NAND Flash is not addressed as a “CE don’t care”. To address it as a “CE don’t care”, connect NCS3 (if SMC_NFCS3 is set) to the NAND Flash CE.

25.7.1.2 NOR Flash
Hardware Configuration

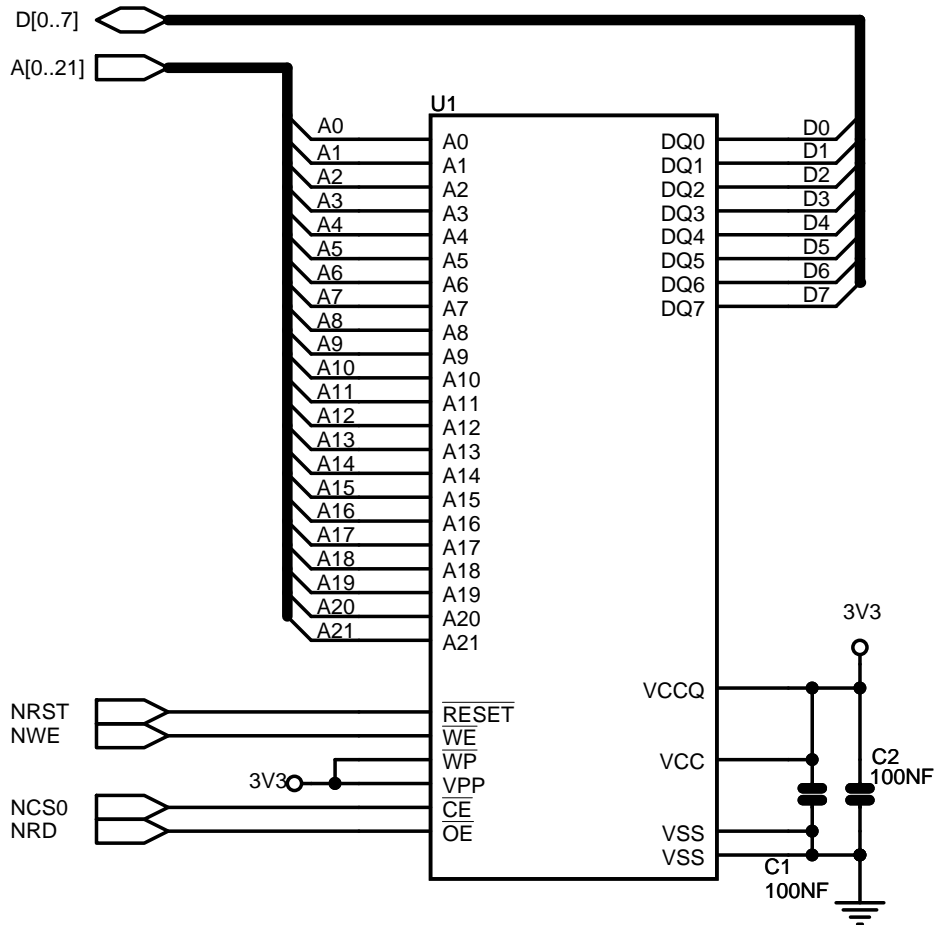

Software Configuration

Configure the Static Memory Controller CS0 Setup, Pulse, Cycle and Mode depending on Flash timings and system bus frequency.

25.8 Standard Read and Write Protocols

In the following sections, NCS represents one of the NCS[0..3] chip select lines.

25.8.1 Read Waveforms

The read cycle is shown on [Figure 25-5](#).

The read cycle starts with the address setting on the memory address bus.

Figure 25-5. Standard Read Cycle

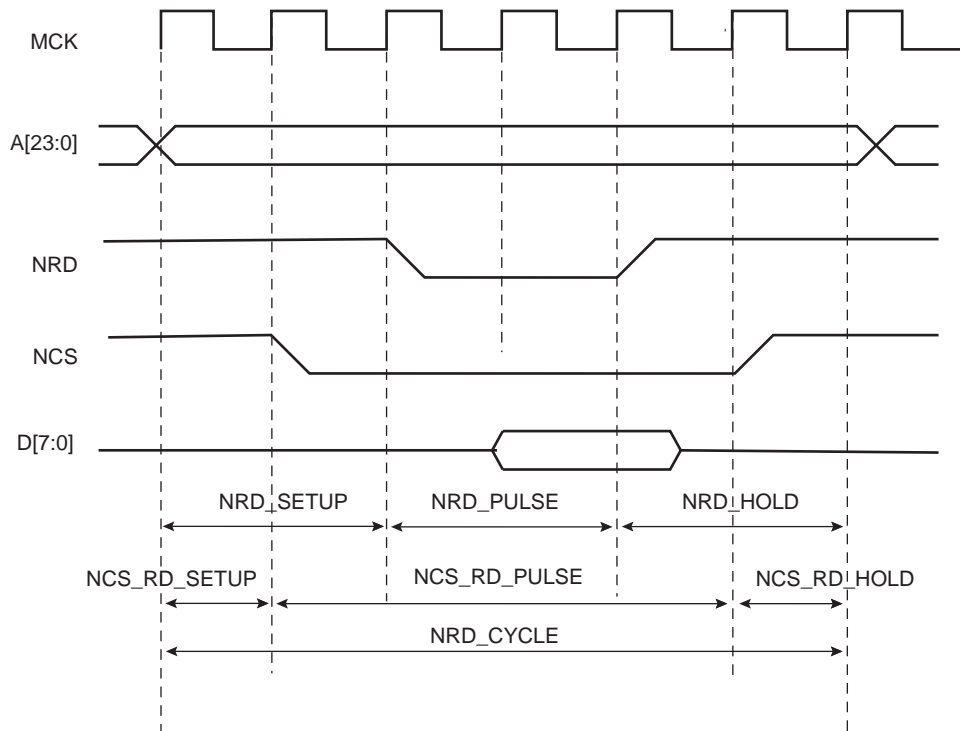

25.8.1.1 NRD Waveform

The NRD signal is characterized by a setup timing, a pulse width and a hold timing.

1. **NRD_SETUP:** the NRD setup time is defined as the setup of address before the NRD falling edge;
2. **NRD_PULSE:** the NRD pulse length is the time between NRD falling edge and NRD rising edge;
3. **NRD_HOLD:** the NRD hold time is defined as the hold time of address after the NRD rising edge.

25.8.1.2 NCS Waveform

Similarly, the NCS signal can be divided into a setup time, pulse length and hold time:

1. **NCS_RD_SETUP:** the NCS setup time is defined as the setup time of address before the NCS falling edge.
2. **NCS_RD_PULSE:** the NCS pulse length is the time between NCS falling edge and NCS rising edge;
3. **NCS_RD_HOLD:** the NCS hold time is defined as the hold time of address after the NCS rising edge.

25.8.1.3 Read Cycle

The NRD_CYCLE time is defined as the total duration of the read cycle, i.e., from the time where address is set on the address bus to the point where address may change. The total read cycle time is equal to:

$$\begin{aligned} \text{NRD_CYCLE} &= \text{NRD_SETUP} + \text{NRD_PULSE} + \text{NRD_HOLD} \\ &= \text{NCS_RD_SETUP} + \text{NCS_RD_PULSE} + \text{NCS_RD_HOLD} \end{aligned}$$

All NRD and NCS timings are defined separately for each chip select as an integer number of Master Clock cycles. To ensure that the NRD and NCS timings are coherent, user must define the total read cycle instead of the hold timing. NRD_CYCLE implicitly defines the NRD hold time and NCS hold time as:

$$\begin{aligned} \text{NRD_HOLD} &= \text{NRD_CYCLE} - \text{NRD_SETUP} - \text{NRD_PULSE} \\ \text{NCS_RD_HOLD} &= \text{NRD_CYCLE} - \text{NCS_RD_SETUP} - \text{NCS_RD_PULSE} \end{aligned}$$

25.8.1.4 Null Delay Setup and Hold

If null setup and hold parameters are programmed for NRD and/or NCS, NRD and NCS remain active continuously in case of consecutive read cycles in the same memory (see [Figure 25-6](#)).

Figure 25-6. No Setup, No Hold on NRD and NCS Read Signals

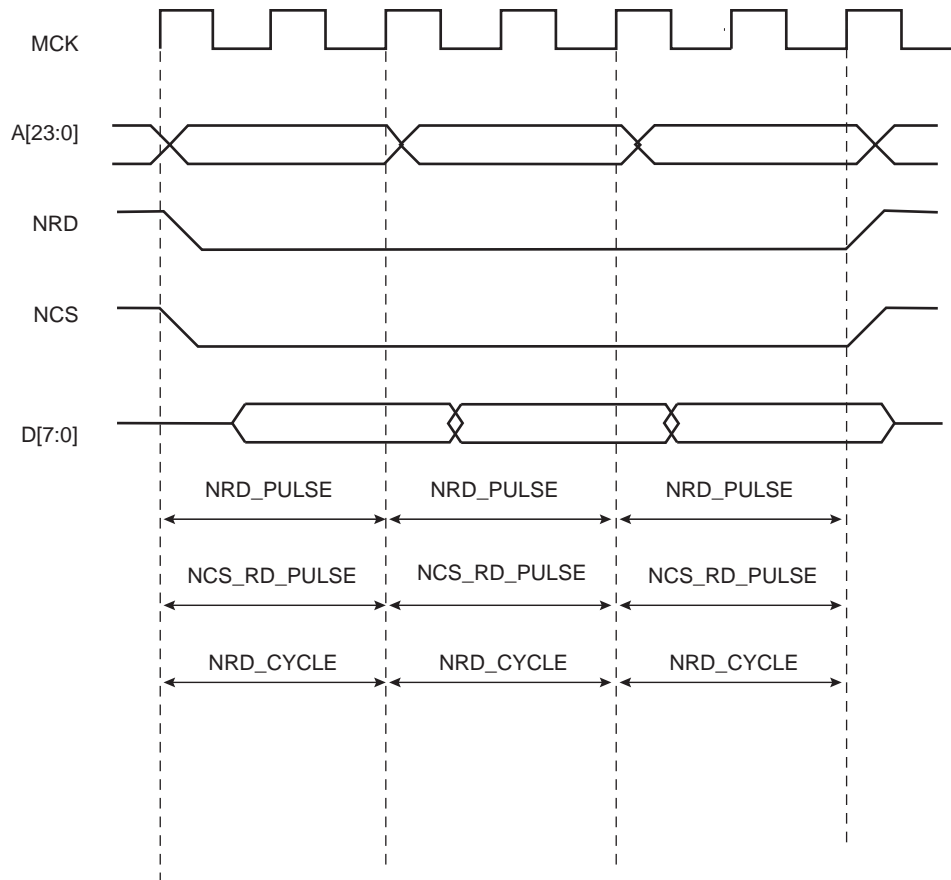

25.8.1.5 Null Pulse

Programming null pulse is not permitted. Pulse must be at least set to 1. A null value leads to unpredictable behavior.

25.8.2 Read Mode

As NCS and NRD waveforms are defined independently of one other, the SMC needs to know when the read data is available on the data bus. The SMC does not compare NCS and NRD timings to know which signal rises first. The READ_MODE parameter in the SMC_MODE register of the corresponding chip select indicates which signal of NRD and NCS controls the read operation.

25.8.2.1 Read is Controlled by NRD (READ_MODE = 1):

Figure 25-7 shows the waveforms of a read operation of a typical asynchronous RAM. The read data is available t_{PACC} after the falling edge of NRD, and turns to 'Z' after the rising edge of NRD. In this case, the READ_MODE must be set to 1 (read is controlled by NRD), to indicate that data is available with the rising edge of NRD. The SMC samples the read data internally on the rising edge of Master Clock that generates the rising edge of NRD, whatever the programmed waveform of NCS may be.

Figure 25-7. READ_MODE = 1: Data is sampled by SMC before the rising edge of NRD

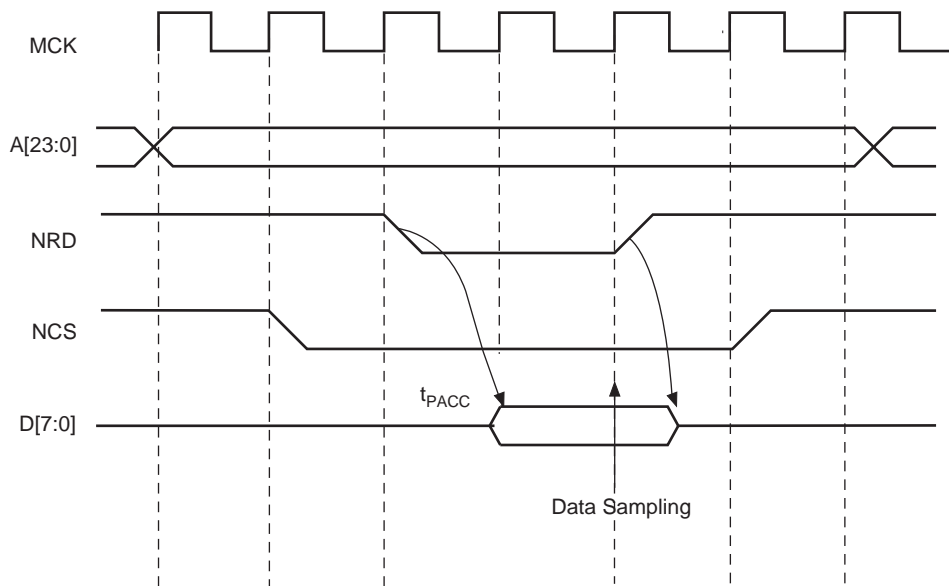

25.8.2.2 Read is Controlled by NCS (READ_MODE = 0)

Figure 25-8 shows the typical read cycle of an LCD module. The read data is valid t_{PACC} after the falling edge of the NCS signal and remains valid until the rising edge of NCS. Data must be sampled when NCS is raised. In that case, the READ_MODE must be set to 0 (read is controlled by NCS): the SMC internally samples the data on the rising edge of Master Clock that generates the rising edge of NCS, whatever the programmed waveform of NRD may be.

Figure 25-8. READ_MODE = 0: Data is sampled by SMC before the rising edge of NCS

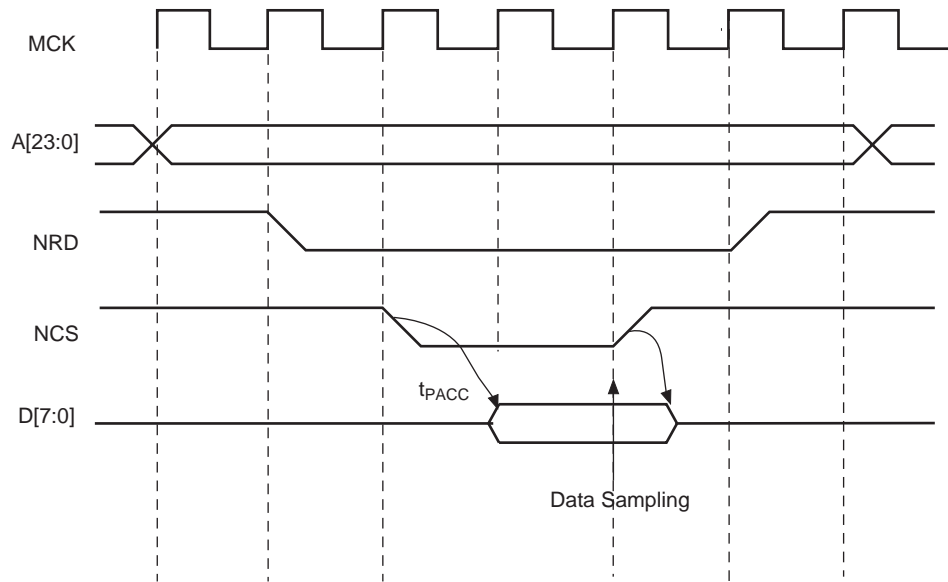

25.8.3 Write Waveforms

The write protocol is similar to the read protocol. It is depicted in [Figure 25-9](#). The write cycle starts with the address setting on the memory address bus.

25.8.3.1 NWE Waveforms

The NWE signal is characterized by a setup timing, a pulse width and a hold timing.

1. NWE_SETUP: the NWE setup time is defined as the setup of address and data before the NWE falling edge;
2. NWE_PULSE: The NWE pulse length is the time between NWE falling edge and NWE rising edge;
3. NWE_HOLD: The NWE hold time is defined as the hold time of address and data after the NWE rising edge.

25.8.3.2 NCS Waveforms

The NCS signal waveforms in write operation are not the same that those applied in read operations, but are separately defined:

1. NCS_WR_SETUP: the NCS setup time is defined as the setup time of address before the NCS falling edge.
2. NCS_WR_PULSE: the NCS pulse length is the time between NCS falling edge and NCS rising edge;
3. NCS_WR_HOLD: the NCS hold time is defined as the hold time of address after the NCS rising edge.

Figure 25-9. Write Cycle

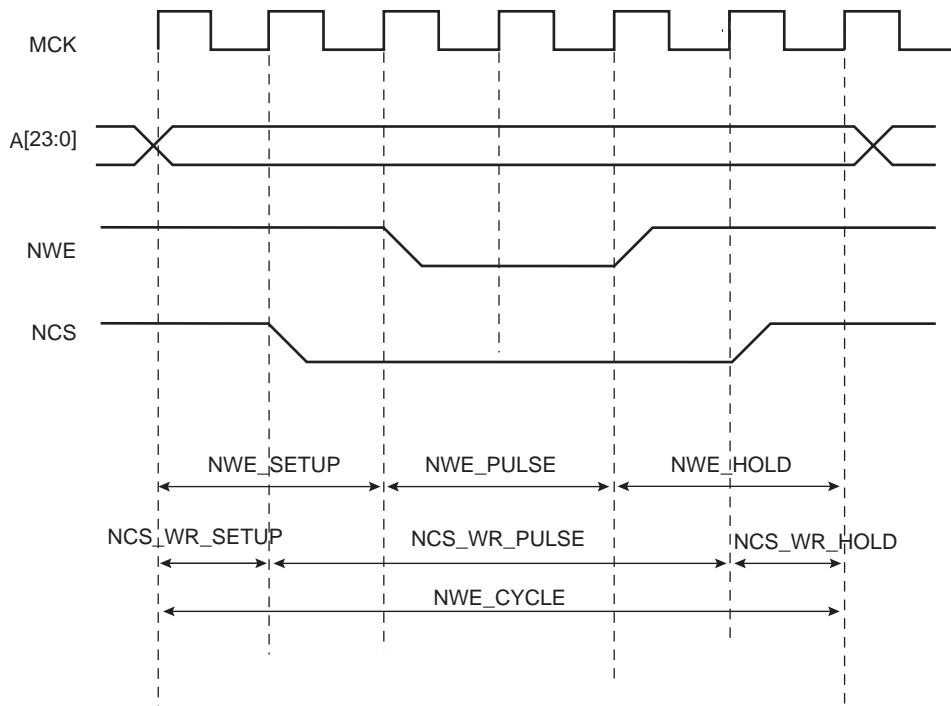

25.8.3.3 Write Cycle

The `write_cycle` time is defined as the total duration of the write cycle, that is, from the time where address is set on the address bus to the point where address may change. The total write cycle time is equal to:

$$\begin{aligned} \text{NWE_CYCLE} &= \text{NWE_SETUP} + \text{NWE_PULSE} + \text{NWE_HOLD} \\ &= \text{NCS_WR_SETUP} + \text{NCS_WR_PULSE} + \text{NCS_WR_HOLD} \end{aligned}$$

All NWE and NCS (write) timings are defined separately for each chip select as an integer number of Master Clock cycles. To ensure that the NWE and NCS timings are coherent, the user must define the total write cycle instead of the hold timing. This implicitly defines the NWE hold time and NCS (write) hold times as:

$$\begin{aligned} \text{NWE_HOLD} &= \text{NWE_CYCLE} - \text{NWE_SETUP} - \text{NWE_PULSE} \\ \text{NCS_WR_HOLD} &= \text{NWE_CYCLE} - \text{NCS_WR_SETUP} - \text{NCS_WR_PULSE} \end{aligned}$$

25.8.3.4 Null Delay Setup and Hold

If null setup parameters are programmed for NWE and/or NCS, NWE and/or NCS remain active continuously in case of consecutive write cycles in the same memory (see [Figure 25-10](#)). However, for devices that perform write operations on the rising edge of NWE or NCS, such as SRAM, either a setup or a hold must be programmed.

Figure 25-10. Null Setup and Hold Values of NCS and NWE in Write Cycle

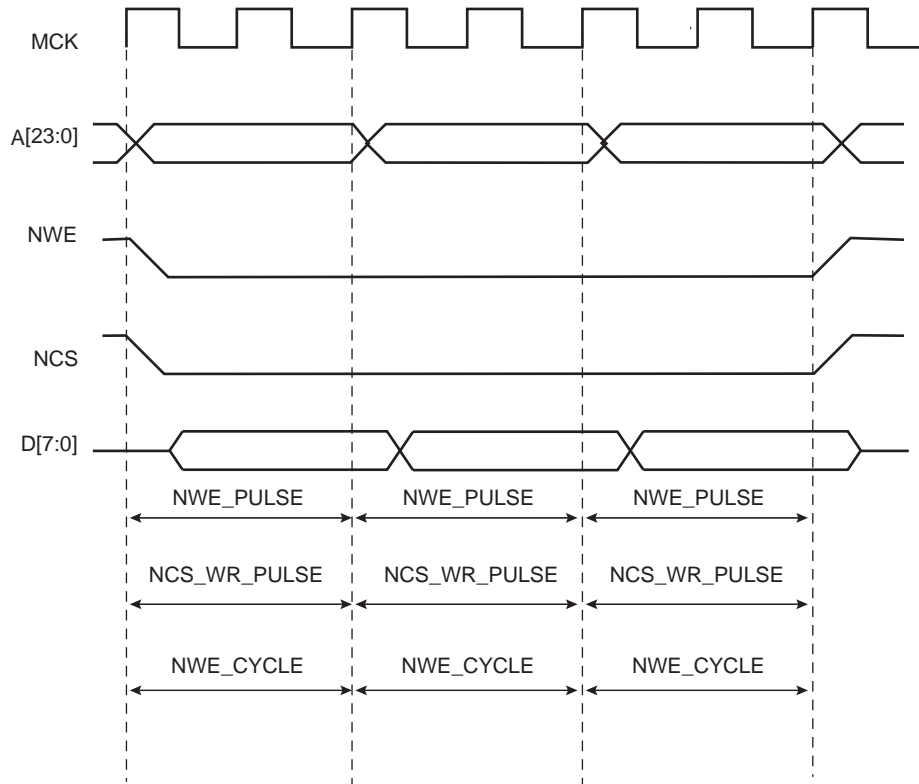

25.8.3.5 Null Pulse

Programming null pulse is not permitted. Pulse must be at least set to 1. A null value leads to unpredictable behavior.

25.8.4 Write Mode

The WRITE_MODE parameter in the SMC_MODE register of the corresponding chip select indicates which signal controls the write operation.

25.8.4.1 Write is Controlled by NWE (WRITE_MODE = 1):

Figure 25-11 shows the waveforms of a write operation with WRITE_MODE set to 1. The data is put on the bus during the pulse and hold steps of the NWE signal. The internal data buffers are switched to output mode after the NWE_SETUP time, and until the end of the write cycle, regardless of the programmed waveform on NCS.

Figure 25-11. WRITE_MODE = 1. The write operation is controlled by NWE

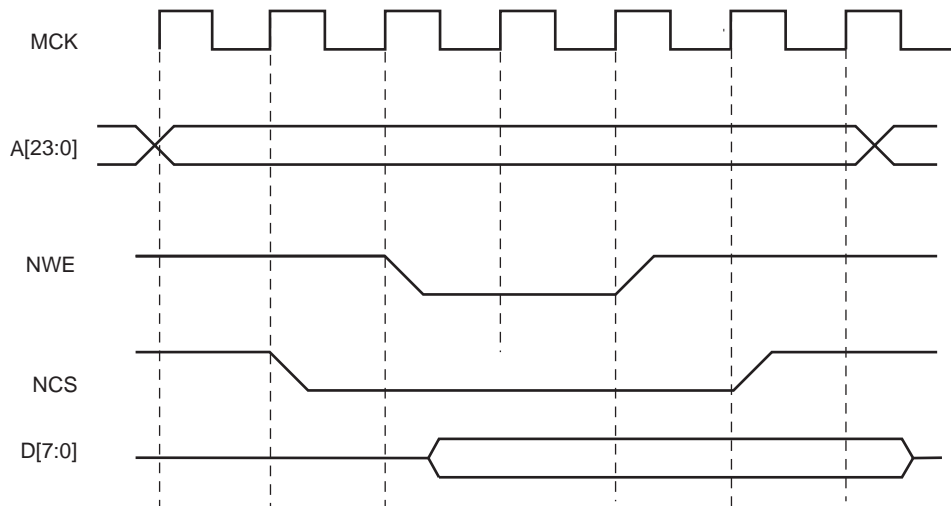

25.8.4.2 Write is Controlled by NCS (WRITE_MODE = 0)

Figure 25-12 shows the waveforms of a write operation with WRITE_MODE set to 0. The data is put on the bus during the pulse and hold steps of the NCS signal. The internal data buffers are switched to output mode after the NCS_WR_SETUP time, and until the end of the write cycle, regardless of the programmed waveform on NWE.

Figure 25-12. WRITE_MODE = 0. The write operation is controlled by NCS

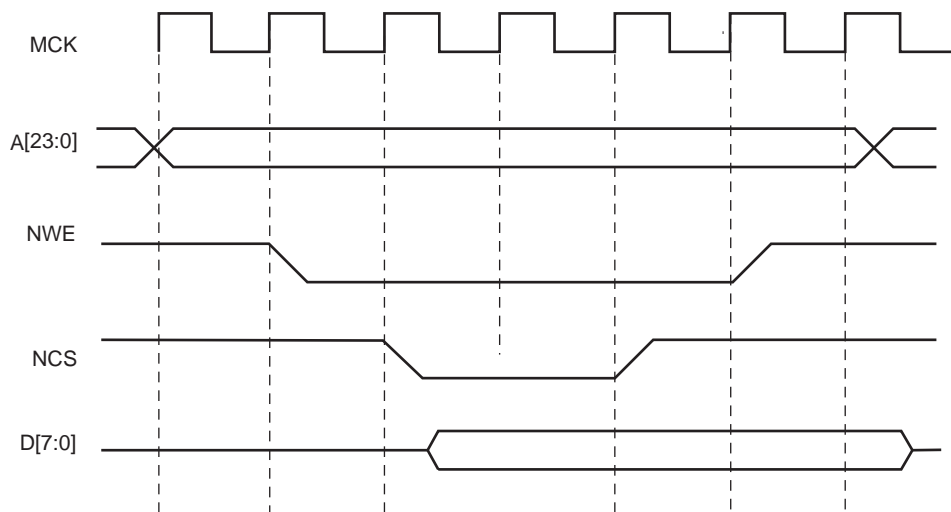

25.8.5 Write Protected Registers

To prevent any single software error that may corrupt SMC behavior, the registers listed below can be write-protected by setting the WPEN bit in the SMC Write Protect Mode Register (SMC_WPMR).

If a write access in a write-protected register is detected, then the WPVS flag in the SMC Write Protect Status Register (SMC_WPSR) is set and the field WPVSRC indicates in which register the write access has been attempted.

The WPVS flag is automatically reset after reading the SMC Write Protect Status Register (SMC_WPSR).

List of the write-protected registers:

- [Section 25.15.1 "SMC Setup Register"](#)
- [Section 25.15.2 "SMC Pulse Register"](#)
- [Section 25.15.3 "SMC Cycle Register"](#)
- [Section 25.15.4 "SMC MODE Register"](#)

25.8.6 Coding Timing Parameters

All timing parameters are defined for one chip select and are grouped together in one SMC_REGISTER according to their type.

The SMC_SETUP register groups the definition of all setup parameters:

- NRD_SETUP, NCS_RD_SETUP, NWE_SETUP, NCS_WR_SETUP

The SMC_PULSE register groups the definition of all pulse parameters:

- NRD_PULSE, NCS_RD_PULSE, NWE_PULSE, NCS_WR_PULSE

The SMC_CYCLE register groups the definition of all cycle parameters:

- NRD_CYCLE, NWE_CYCLE

[Table](#) shows how the timing parameters are coded and their permitted range.

Coding and Range of Timing Parameters

Coded Value	Number of Bits	Effective Value	Permitted Range	
			Coded Value	Effective Value
setup [5:0]	6	$128 \times \text{setup}[5] + \text{setup}[4:0]$	$0 \leq 31$	$0 \leq 128+31$
pulse [6:0]	7	$256 \times \text{pulse}[6] + \text{pulse}[5:0]$	$0 \leq 63$	$0 \leq 256+63$
cycle [8:0]	9	$256 \times \text{cycle}[8:7] + \text{cycle}[6:0]$	$0 \leq 127$	$0 \leq 256+127$ $0 \leq 512+127$ $0 \leq 768+127$

25.8.7 Reset Values of Timing Parameters

[Table 25-2](#) gives the default value of timing parameters at reset.

Table 25-2. Reset Values of Timing Parameters

Register	Reset Value	Description
SMC_SETUP	0x01010101	All setup timings are set to 1
SMC_PULSE	0x01010101	All pulse timings are set to 1
SMC_CYCLE	0x00030003	The read and write operation last 3 Master Clock cycles and provide one hold cycle
WRITE_MODE	1	Write is controlled with NWE
READ_MODE	1	Read is controlled with NRD

25.8.8 Usage Restriction

The SMC does not check the validity of the user-programmed parameters. If the sum of SETUP and PULSE parameters is larger than the corresponding CYCLE parameter, this leads to unpredictable behavior of the SMC.

For read operations:

Null but positive setup and hold of address and NRD and/or NCS can not be guaranteed at the memory interface because of the propagation delay of these signals through external logic and pads. If positive setup and hold values must be verified, then it is strictly recommended to program non-null values so as to cover possible skews between address, NCS and NRD signals.

For write operations:

If a null hold value is programmed on NWE, the SMC can guarantee a positive hold of address and NCS signal after the rising edge of NWE. This is true for WRITE_MODE = 1 only. See ["Early Read Wait State"](#) on page 430.

For read and write operations: a null value for pulse parameters is forbidden and may lead to unpredictable behavior.

In read and write cycles, the setup and hold time parameters are defined in reference to the address bus. For external devices that require setup and hold time between NCS and NRD signals (read), or between NCS and NWE signals (write), these setup and hold times must be converted into setup and hold times in reference to the address bus.

25.9 Scrambling/Unscrambling Function

The external data bus D[7:0] can be scrambled in order to prevent intellectual property data located in off-chip memories from being easily recovered by analyzing data at the package pin level of either microcontroller or memory device.

The scrambling and unscrambling are performed on-the-fly without additional wait states.

The scrambling method depends on two user-configurable key registers, SMC_KEY1 and SMC_KEY2. These key registers are only accessible in write mode.

The key must be securely stored in a reliable non-volatile memory in order to recover data from the off-chip memory. Any data scrambled with a given key cannot be recovered if the key is lost.

The scrambling/unscrambling function can be enabled or disabled by programming the SMC_OCMS register.

When multiple chip selects are handled, it is possible to configure the scrambling function per chip select using the OCMS field in the SMC_OCMS registers.

25.10 Automatic Wait States

Under certain circumstances, the SMC automatically inserts idle cycles between accesses to avoid bus contention or operation conflict.

25.10.1 Chip Select Wait States

The SMC always inserts an idle cycle between 2 transfers on separate chip selects. This idle cycle ensures that there is no bus contention between the de-activation of one device and the activation of the next one.

During chip select wait state, all control lines are turned inactive: NWR, NCS[0..3], NRD lines are all set to 1.

Figure 25-13 illustrates a chip select wait state between access on Chip Select 0 and Chip Select 2.

Figure 25-13. Chip Select Wait State between a Read Access on NCS0 and a Write Access on NCS2

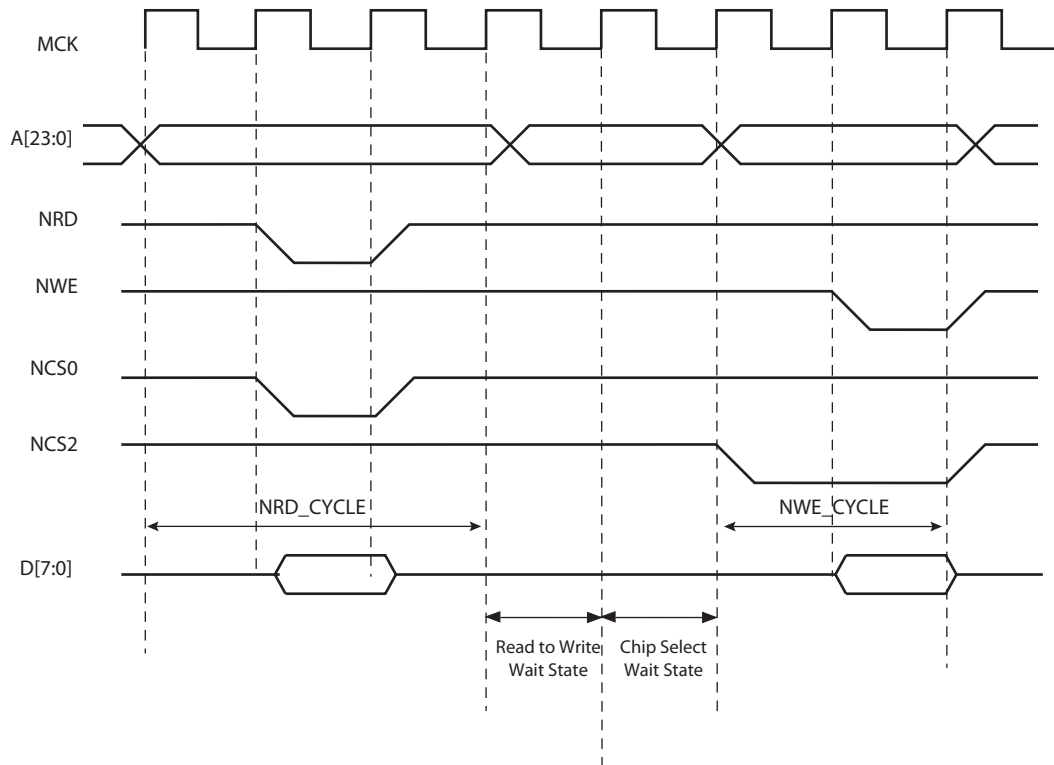

25.10.2 Early Read Wait State

In some cases, the SMC inserts a wait state cycle between a write access and a read access to allow time for the write cycle to end before the subsequent read cycle begins. This wait state is not generated in addition to a chip select wait state. The early read cycle thus only occurs between a write and read access to the same memory device (same chip select).

An early read wait state is automatically inserted if at least one of the following conditions is valid:

- if the write controlling signal has no hold time and the read controlling signal has no setup time (Figure 25-14).
- in NCS write controlled mode (WRITE_MODE = 0), if there is no hold timing on the NCS signal and the NCS_RD_SETUP parameter is set to 0, regardless of the read mode (Figure 25-15). The write operation must end with a NCS rising edge. Without an Early Read Wait State, the write operation could not complete properly.
- in NWE controlled mode (WRITE_MODE = 1) and if there is no hold timing (NWE_HOLD = 0), the feedback of the write control signal is used to control address, data, and chip select lines. If the external write control signal is not inactivated as expected due to load capacitances, an Early Read Wait State is inserted and address, data and control signals are maintained one more cycle. See Figure 25-16.

Figure 25-14. Early Read Wait State: Write with No Hold Followed by Read with No Setup

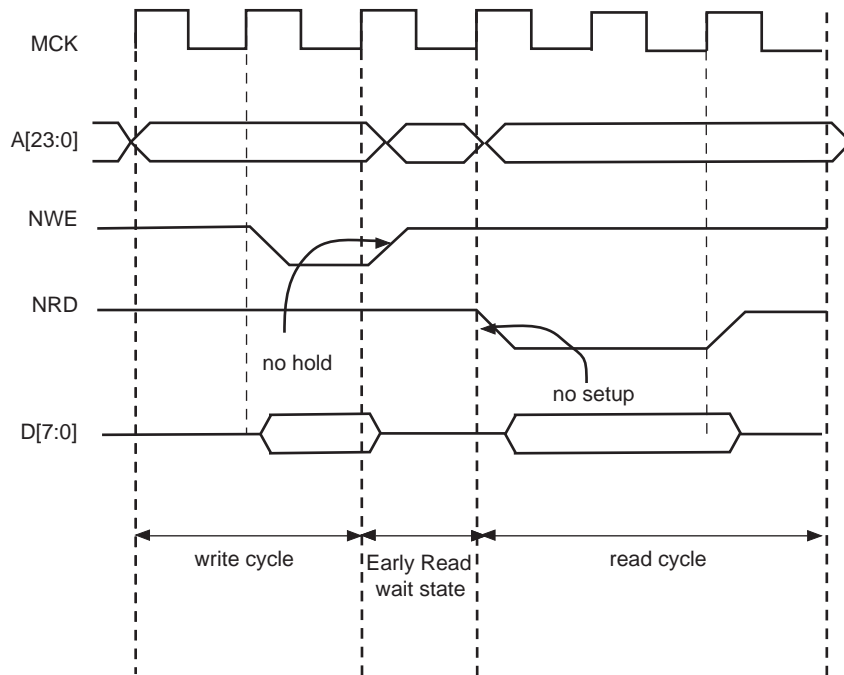

Figure 25-15. Early Read Wait State: NCS Controlled Write with No Hold Followed by a Read with No NCS Setup

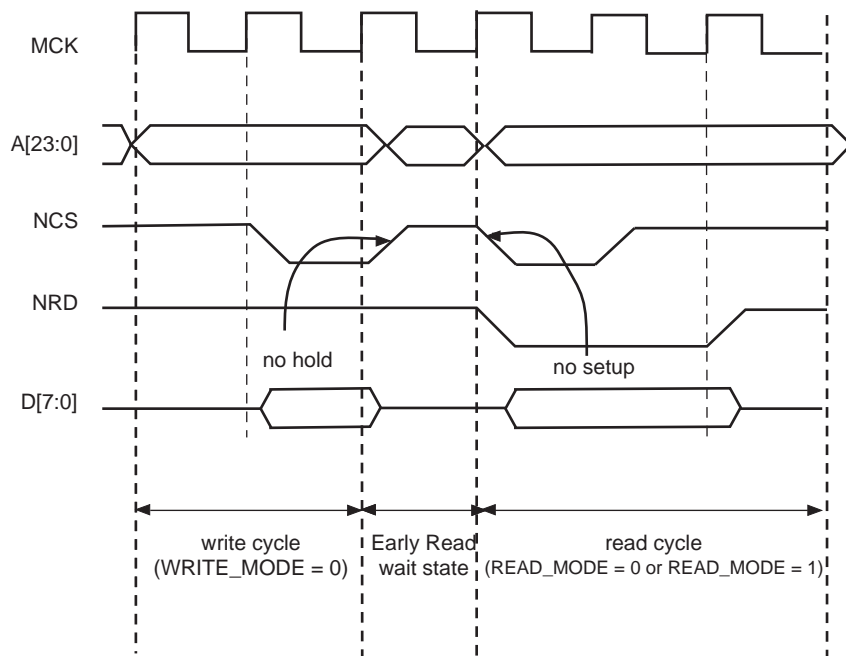
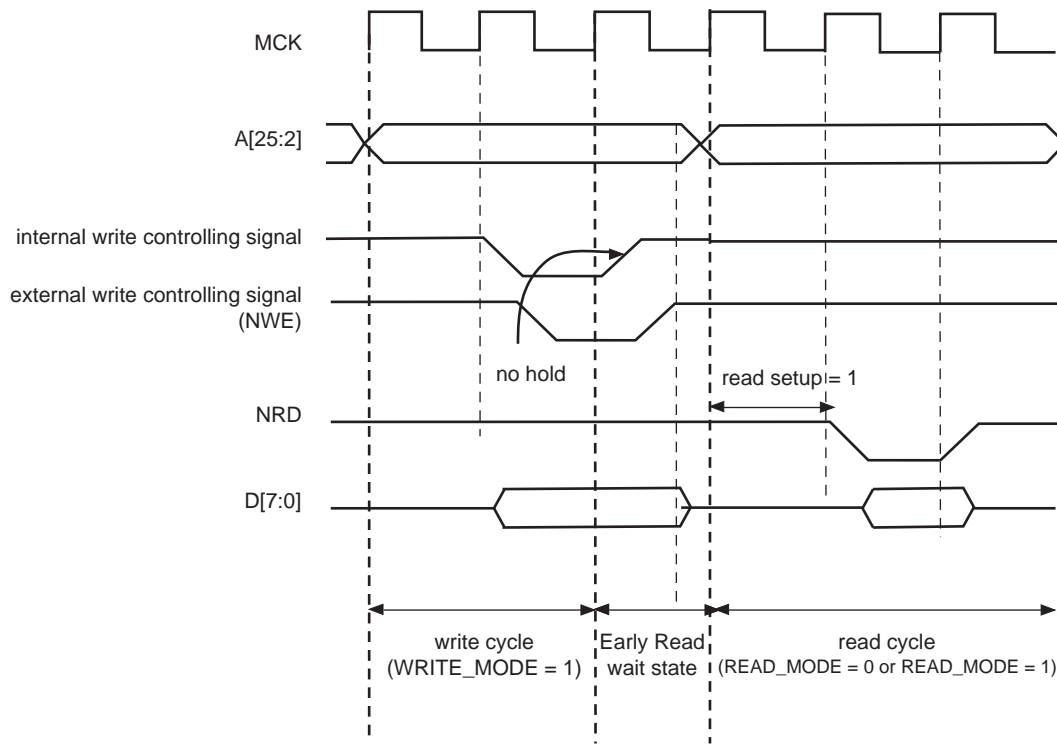

Figure 25-16. Early Read Wait State: NWE-controlled Write with No Hold Followed by a Read with one Set-up Cycle



25.10.3 Reload User Configuration Wait State

The user may change any of the configuration parameters by writing the SMC user interface.

When detecting that a new user configuration has been written in the user interface, the SMC inserts a wait state before starting the next access. The so called "Reload User Configuration Wait State" is used by the SMC to load the new set of parameters to apply to next accesses.

The Reload Configuration Wait State is not applied in addition to the Chip Select Wait State. If accesses before and after re-programming the user interface are made to different devices (Chip Selects), then one single Chip Select Wait State is applied.

On the other hand, if accesses before and after writing the user interface are made to the same device, a Reload Configuration Wait State is inserted, even if the change does not concern the current Chip Select.

25.10.3.1 User Procedure

To insert a Reload Configuration Wait State, the SMC detects a write access to any SMC_MODE register of the user interface. If the user only modifies timing registers (SMC_SETUP, SMC_PULSE, SMC_CYCLE registers) in the user interface, he must validate the modification by writing the SMC_MODE, even if no change was made on the mode parameters.

The user must not change the configuration parameters of an SMC Chip Select (Setup, Pulse, Cycle, Mode) if accesses are performed on this CS during the modification. Any change of the Chip Select parameters, while fetching the code from a memory connected on this CS, may lead to unpredictable behavior. The instructions used to modify the parameters of an SMC Chip Select can be executed from the internal RAM or from a memory connected to another CS.

25.10.3.2 Slow Clock Mode Transition

A Reload Configuration Wait State is also inserted when the Slow Clock Mode is entered or exited, after the end of the current transfer (see “Slow Clock Mode” on page 444).

25.10.4 Read to Write Wait State

Due to an internal mechanism, a wait cycle is always inserted between consecutive read and write SMC accesses.

This wait cycle is referred to as a read to write wait state in this document.

This wait cycle is applied in addition to chip select and reload user configuration wait states when they are to be inserted. See [Figure 25-13 on page 430](#).

25.11 Data Float Wait States

Some memory devices are slow to release the external bus. For such devices, it is necessary to add wait states (data float wait states) after a read access:

- Before starting a read access to a different external memory
- Before starting a write access to the same device or to a different external one.

The Data Float Output Time (t_{DF}) for each external memory device is programmed in the TDF_CYCLES field of the SMC_MODE register for the corresponding chip select. The value of TDF_CYCLES indicates the number of data float wait cycles (between 0 and 15) before the external device releases the bus, and represents the time allowed for the data output to go to high impedance after the memory is disabled.

Data float wait states do not delay internal memory accesses. Hence, a single access to an external memory with long t_{DF} will not slow down the execution of a program from internal memory.

The data float wait states management depends on the READ_MODE and the TDF_MODE fields of the SMC_MODE register for the corresponding chip select.

25.11.1 READ_MODE

Setting the READ_MODE to 1 indicates to the SMC that the NRD signal is responsible for turning off the tri-state buffers of the external memory device. The Data Float Period then begins after the rising edge of the NRD signal and lasts TDF_CYCLES MCK cycles.

When the read operation is controlled by the NCS signal (READ_MODE = 0), the TDF field gives the number of MCK cycles during which the data bus remains busy after the rising edge of NCS.

[Figure 25-17](#) illustrates the Data Float Period in NRD-controlled mode (READ_MODE = 1), assuming a data float period of 2 cycles (TDF_CYCLES = 2). [Figure 25-18](#) shows the read operation when controlled by NCS (READ_MODE = 0) and the TDF_CYCLES parameter equals 3.

Figure 25-17. TDF Period in NRD Controlled Read Access (TDF = 2)

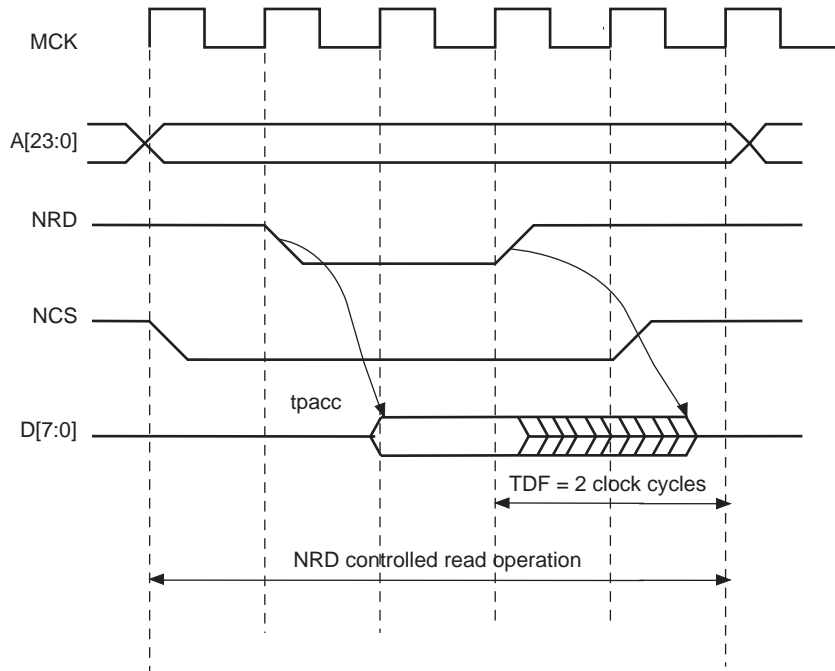
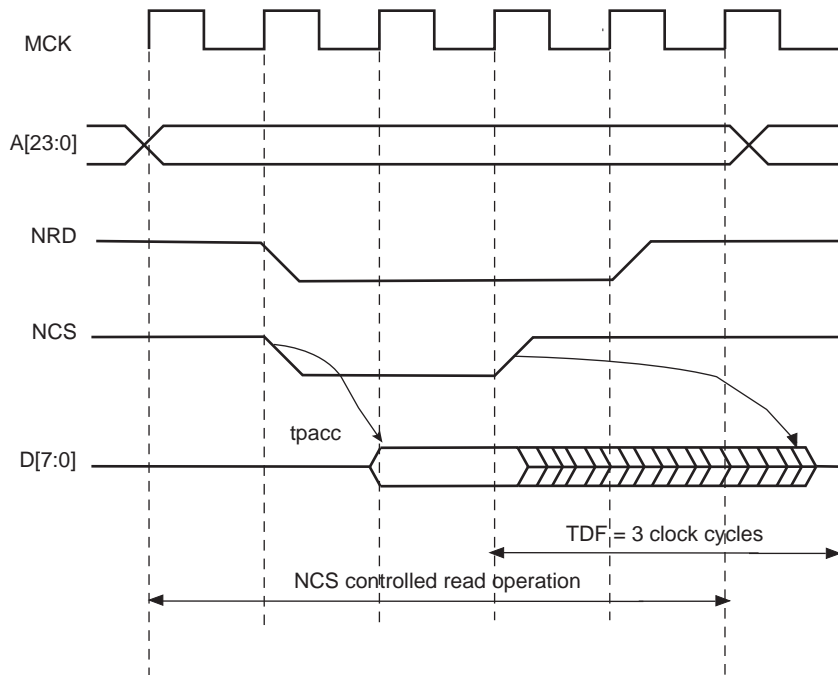

Figure 25-18. TDF Period in NCS Controlled Read Operation (TDF = 3)



25.11.2 TDF Optimization Enabled (TDF_MODE = 1)

When the TDF_MODE of the SMC_MODE register is set to 1 (TDF optimization is enabled), the SMC takes advantage of the setup period of the next access to optimize the number of wait states cycle to insert.

Figure 25-19 shows a read access controlled by NRD, followed by a write access controlled by NWE, on Chip Select 0. Chip Select 0 has been programmed with:

NRD_HOLD = 4; READ_MODE = 1 (NRD controlled)

NWE_SETUP = 3; WRITE_MODE = 1 (NWE controlled)

TDF_CYCLES = 6; TDF_MODE = 1 (optimization enabled).

Figure 25-19. TDF Optimization: No TDF wait states are inserted if the TDF period is over when the next access begins

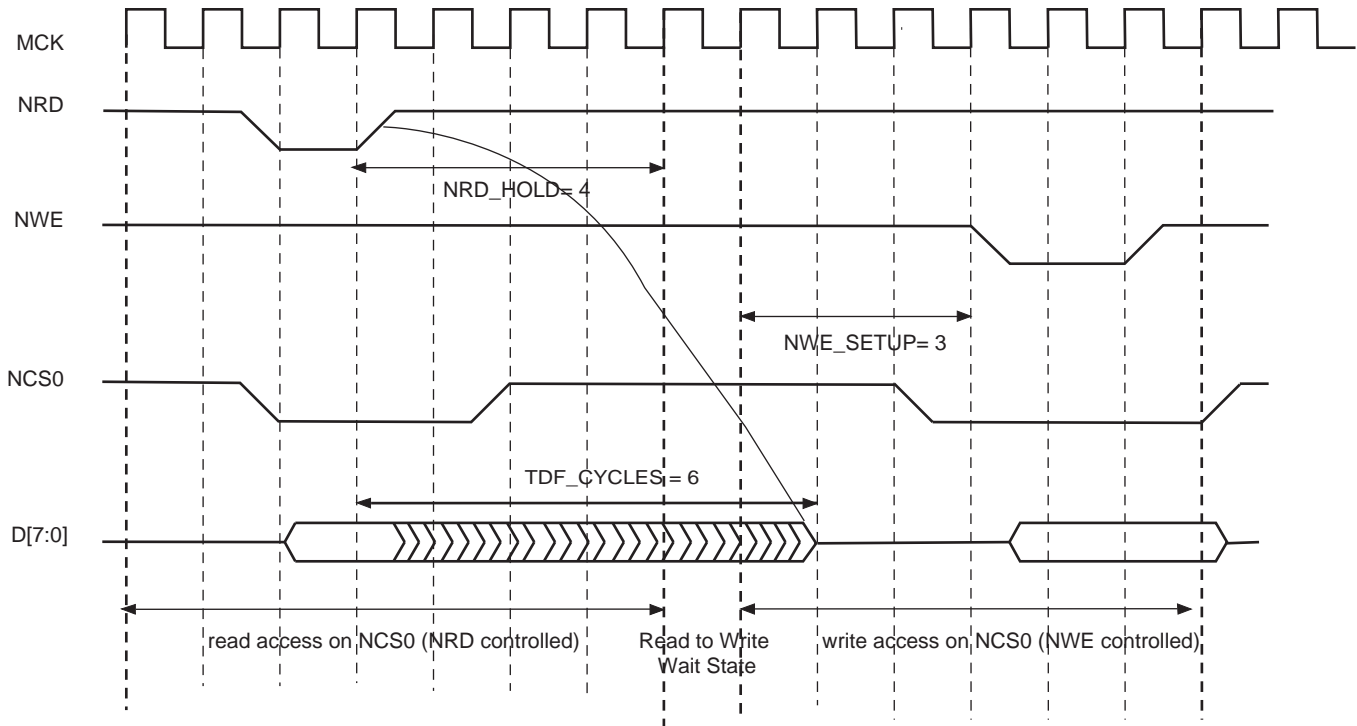

25.11.3 TDF Optimization Disabled (TDF_MODE = 0)

When optimization is disabled, TDF wait states are inserted at the end of the read transfer, so that the data float period is ended when the second access begins. If the hold period of the read1 controlling signal overlaps the data float period, no additional TDF wait states will be inserted.

Figure 25-20, Figure 25-21 and Figure 25-22 illustrate the cases:

- Read access followed by a read access on another chip select,
 - Read access followed by a write access on another chip select,
 - Read access followed by a write access on the same chip select,
- with no TDF optimization.

Figure 25-20. TDF Optimization Disabled (TDF Mode = 0). TDF wait states between 2 read accesses on different chip selects

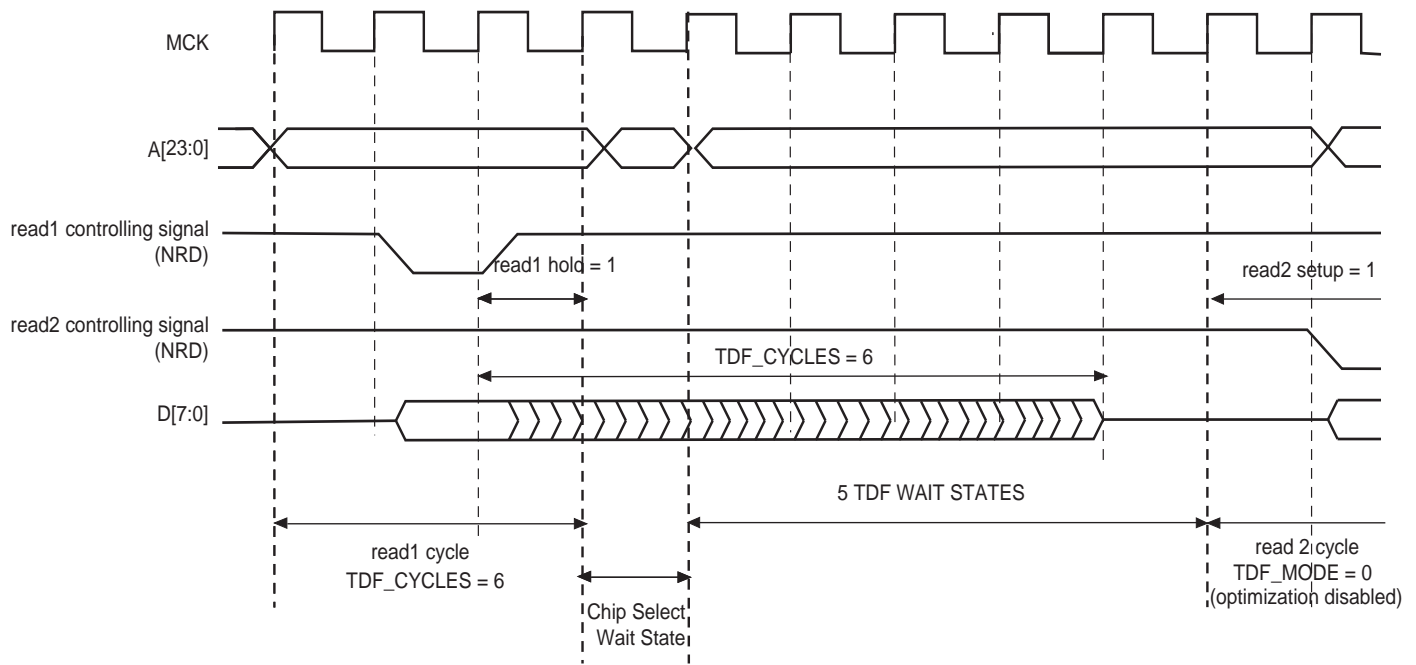

Figure 25-21. TDF Mode = 0: TDF wait states between a read and a write access on different chip selects

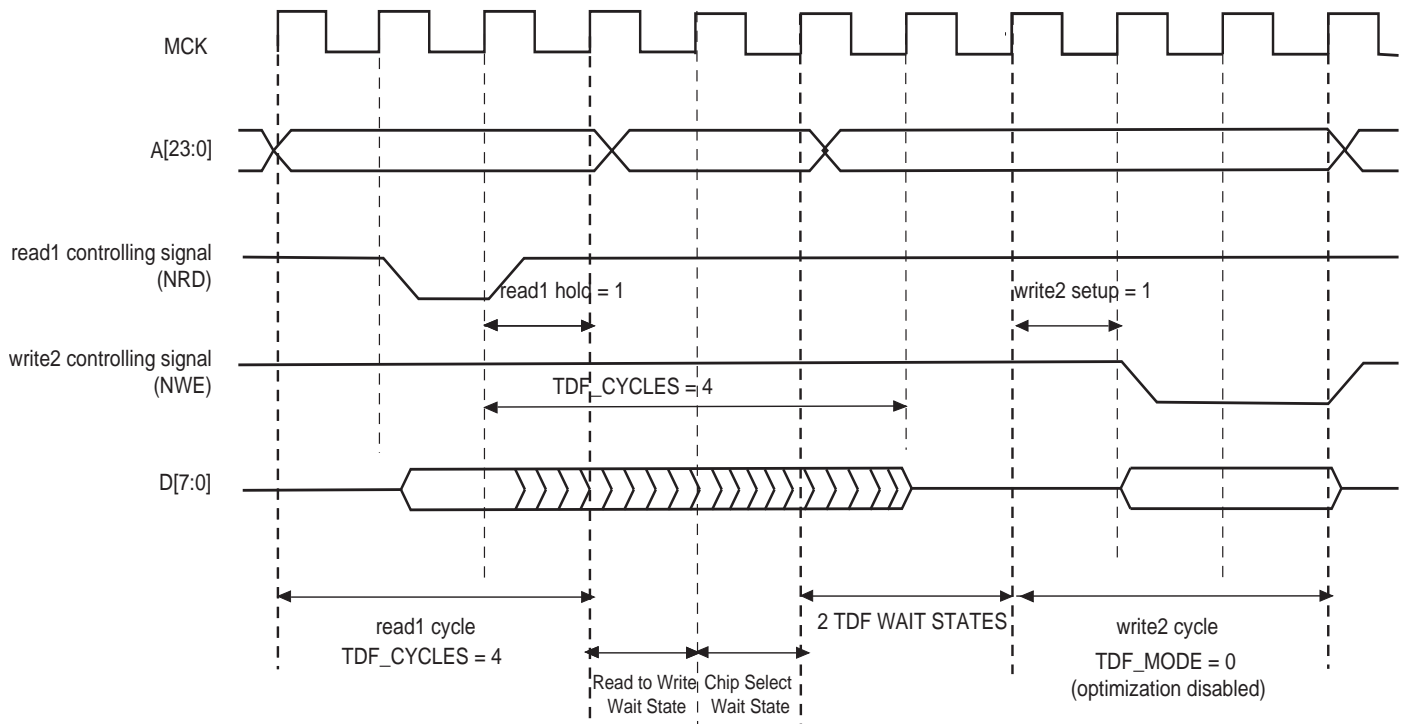
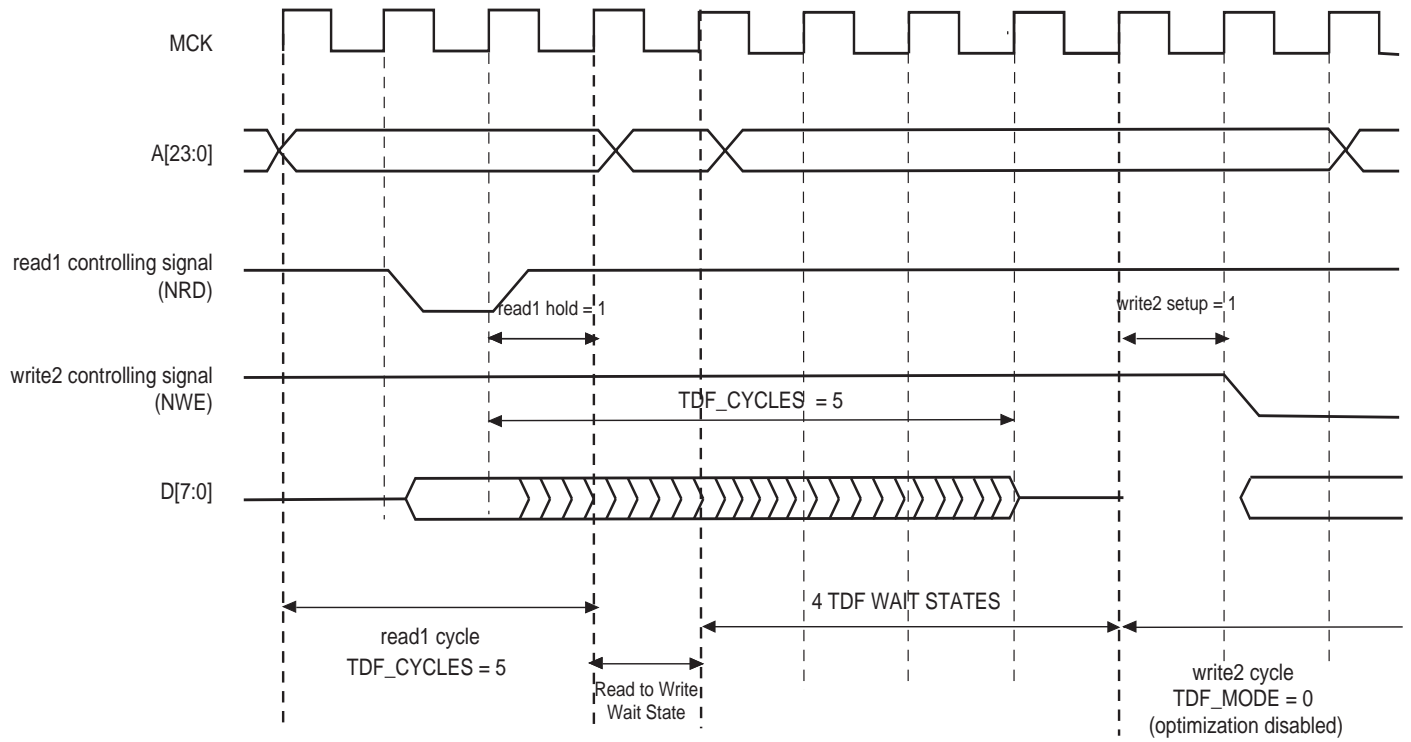

Figure 25-22. TDF Mode = 0: TDF wait states between read and write accesses on the same chip select



25.12 External Wait

Any access can be extended by an external device using the NWAIT input signal of the SMC. The EXNW_MODE field of the SMC_MODE register on the corresponding chip select must be set to either to “10” (frozen mode) or “11” (ready mode). When the EXNW_MODE is set to “00” (disabled), the NWAIT signal is simply ignored on the corresponding chip select. The NWAIT signal delays the read or write operation in regards to the read or write controlling signal, depending on the read and write modes of the corresponding chip select.

25.12.1 Restriction

When one of the EXNW_MODE is enabled, **it is mandatory to program at least one hold cycle for the read/write controlling signal. For that reason, the NWAIT signal cannot be used in Page Mode (“Asynchronous Page Mode” on page 446), or in Slow Clock Mode (“Slow Clock Mode” on page 444).**

The NWAIT signal is assumed to be a response of the external device to the read/write request of the SMC. Then NWAIT is examined by the SMC only in the pulse state of the read or write controlling signal. The assertion of the NWAIT signal outside the expected period has no impact on SMC behavior.

25.12.2 Frozen Mode

When the external device asserts the NWAIT signal (active low), and after internal synchronization of this signal, the SMC state is frozen, i.e., SMC internal counters are frozen, and all control signals remain unchanged. When the resynchronized NWAIT signal is deasserted, the SMC completes the access, resuming the access from the point where it was stopped. See [Figure 25-23](#). This mode must be selected when the external device uses the NWAIT signal to delay the access and to freeze the SMC.

The assertion of the NWAIT signal outside the expected period is ignored as illustrated in [Figure 25-24](#).

Figure 25-23. Write Access with NWAIT Assertion in Frozen Mode (EXNW_MODE = 10)

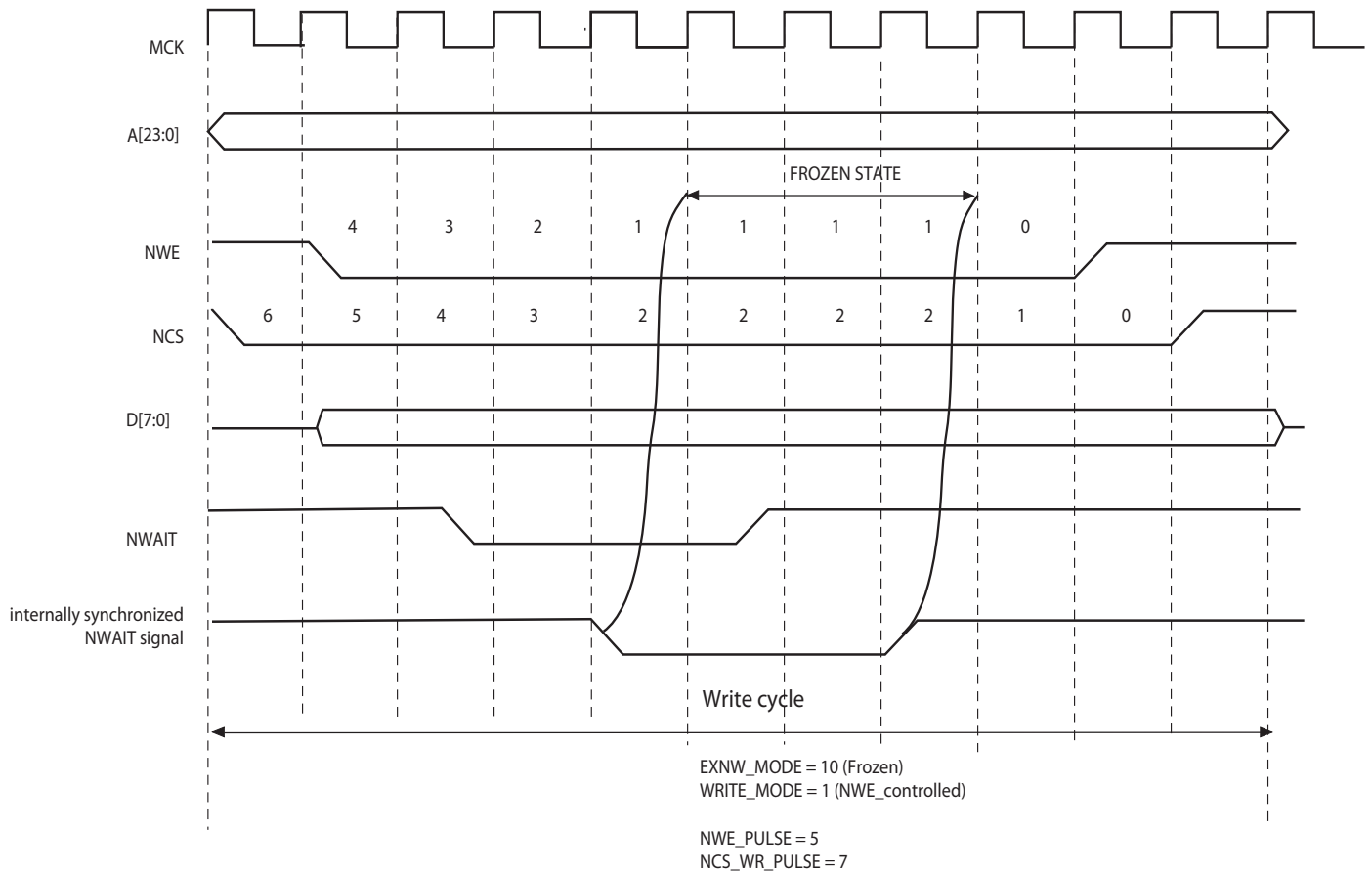
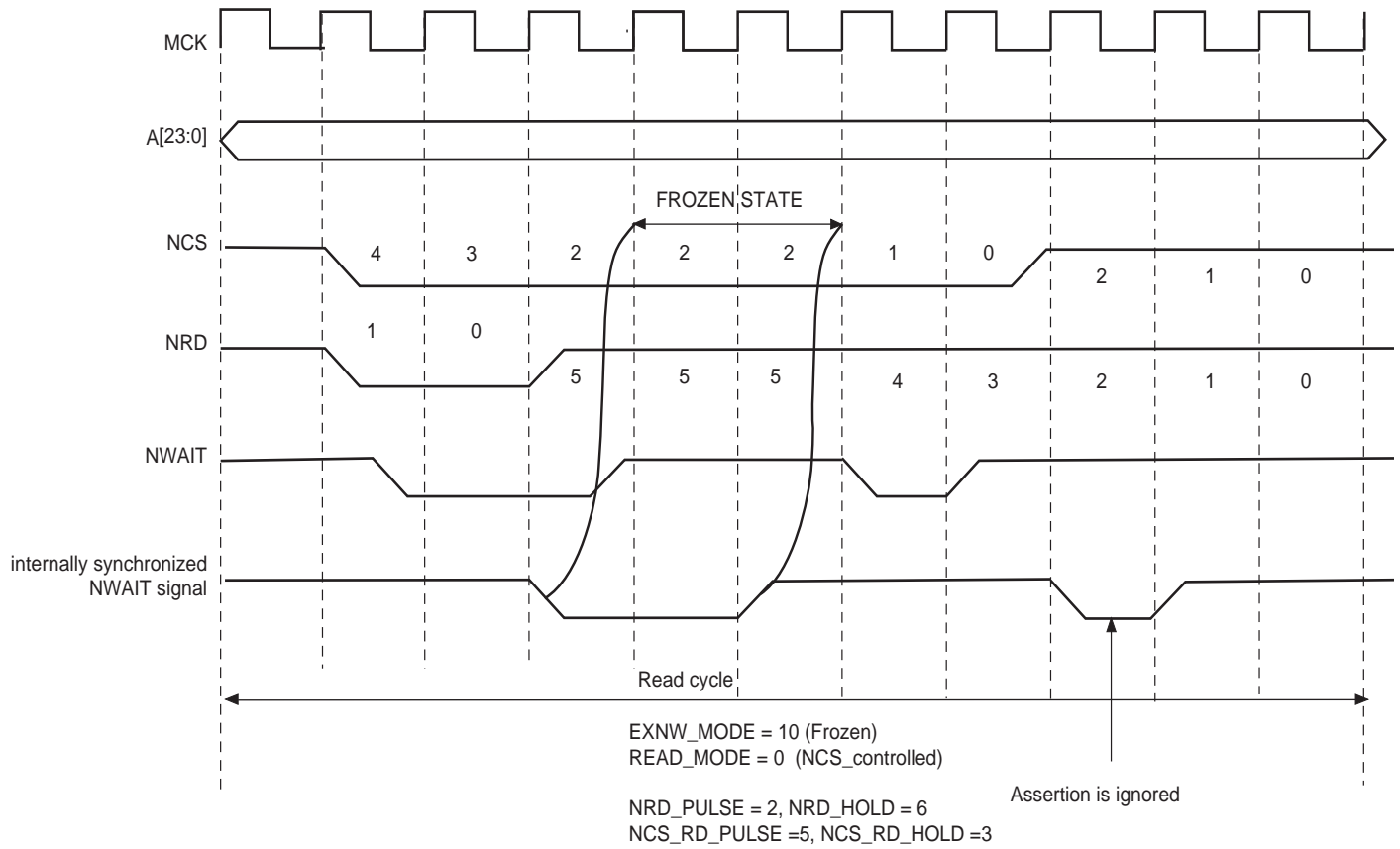

Figure 25-24. Read Access with NWAIT Assertion in Frozen Mode (EXNW_MODE = 10)



25.12.3 Ready Mode

In Ready mode ($EXNW_MODE = 11$), the SMC behaves differently. Normally, the SMC begins the access by down counting the setup and pulse counters of the read/write controlling signal. In the last cycle of the pulse phase, the resynchronized NWAIT signal is examined.

If asserted, the SMC suspends the access as shown in [Figure 25-25](#) and [Figure 25-26](#). After deassertion, the access is completed: the hold step of the access is performed.

This mode must be selected when the external device uses deassertion of the NWAIT signal to indicate its ability to complete the read or write operation.

If the NWAIT signal is deasserted before the end of the pulse, or asserted after the end of the pulse of the controlling read/write signal, it has no impact on the access length as shown in [Figure 25-26](#).

Figure 25-25. NWAIT Assertion in Write Access: Ready Mode ($EXNW_MODE = 11$)

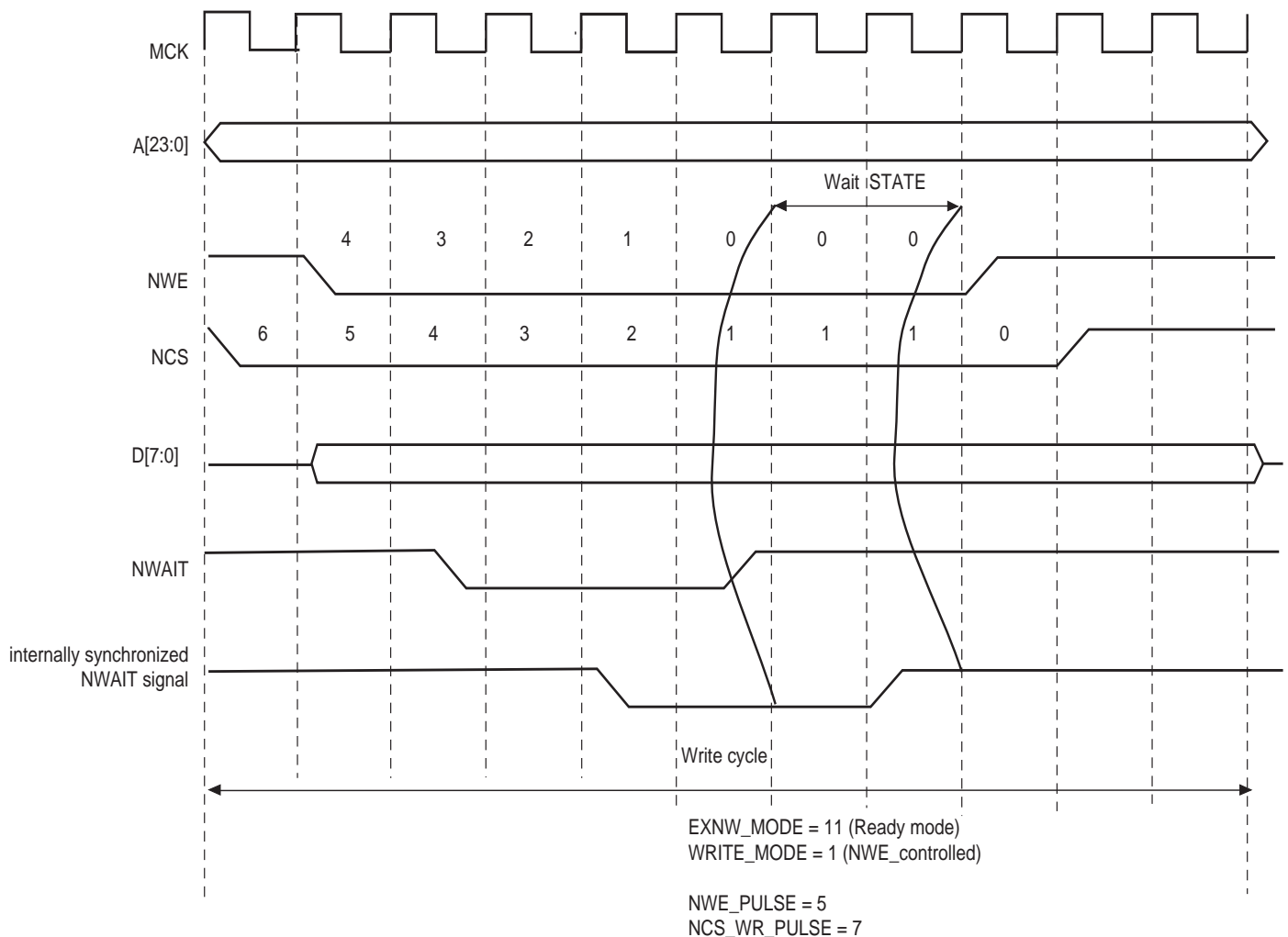
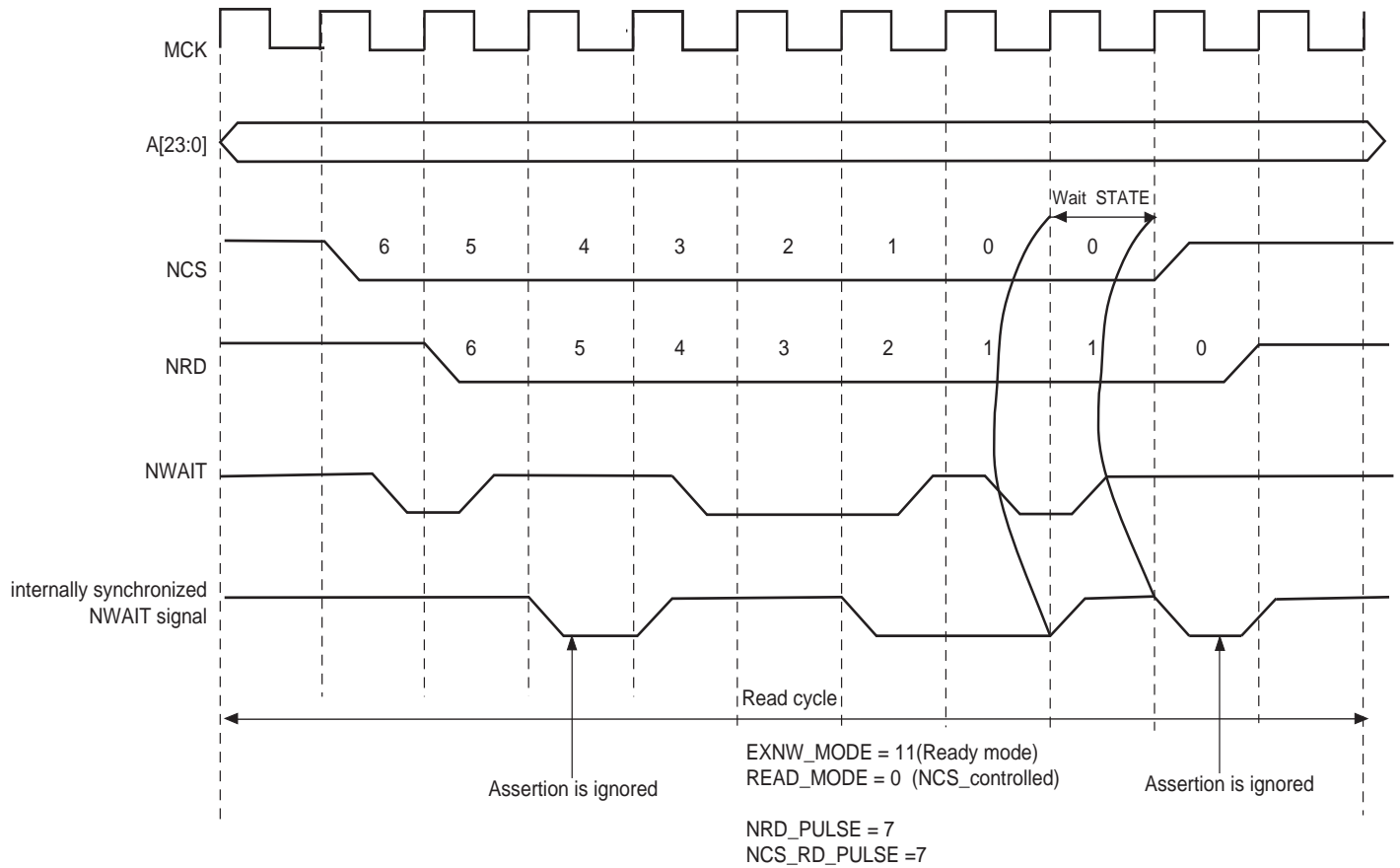

Figure 25-26. NWAIT Assertion in Read Access: Ready Mode (EXNW_MODE = 11)



25.12.4 NWAIT Latency and Read/Write Timings

There may be a latency between the assertion of the read/write controlling signal and the assertion of the NWAIT signal by the device. The programmed pulse length of the read/write controlling signal must be at least equal to this latency plus the 2 cycles of resynchronization + 1 cycle. Otherwise, the SMC may enter the hold state of the access without detecting the NWAIT signal assertion. This is true in frozen mode as well as in ready mode. This is illustrated on [Figure 25-27](#).

When EXNW_MODE is enabled (ready or frozen), the user must program a pulse length of the read and write controlling signal of at least:

$$\text{minimal pulse length} = \text{NWAIT latency} + 2 \text{ resynchronization cycles} + 1 \text{ cycle}$$

Figure 25-27. NWAIT Latency

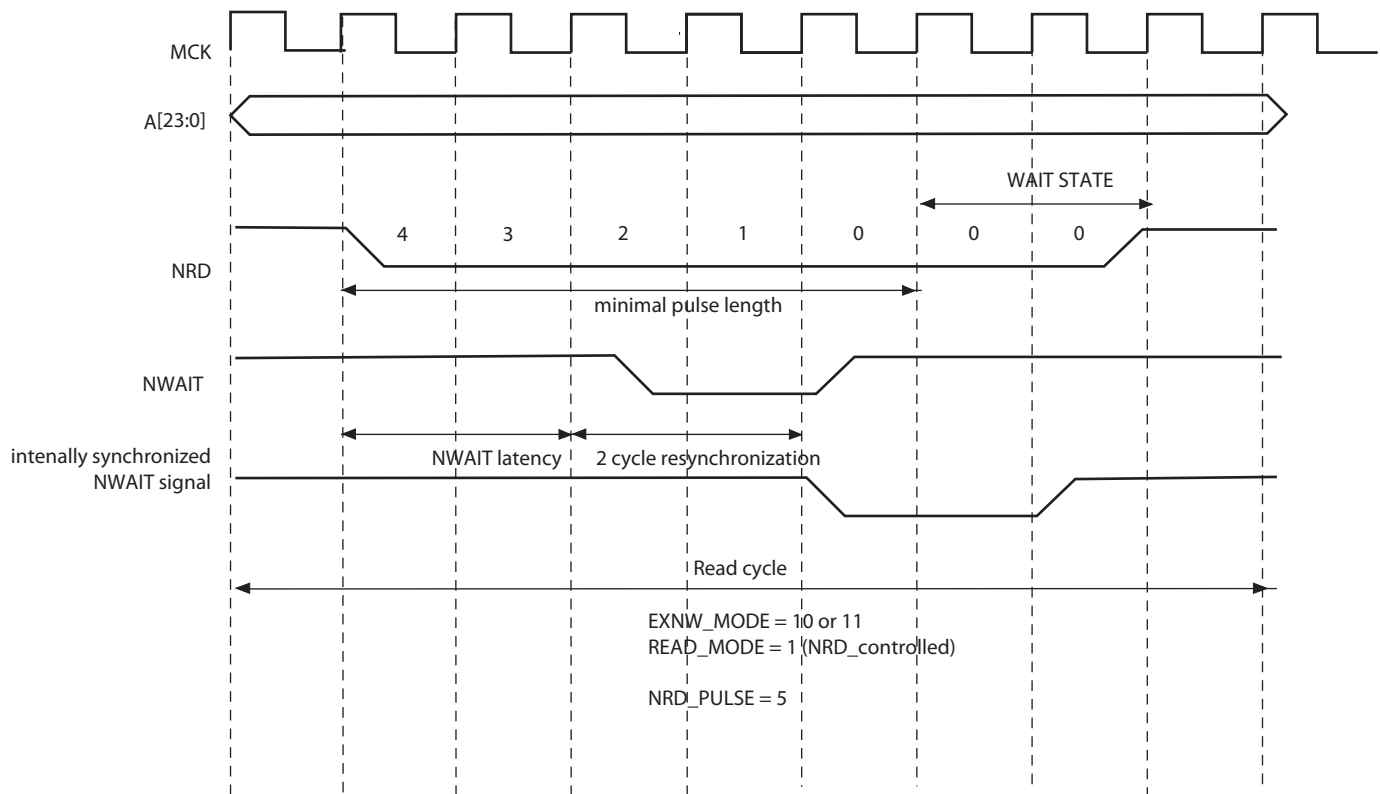

25.13 Slow Clock Mode

The SMC is able to automatically apply a set of “slow clock mode” read/write waveforms when an internal signal driven by the Power Management Controller is asserted because MCK has been turned to a very slow clock rate (typically 32kHz clock rate). In this mode, the user-programmed waveforms are ignored and the slow clock mode waveforms are applied. This mode is provided so as to avoid reprogramming the User Interface with appropriate waveforms at very slow clock rate. When activated, the slow mode is active on all chip selects.

25.13.1 Slow Clock Mode Waveforms

Figure 25-28 illustrates the read and write operations in slow clock mode. They are valid on all chip selects. Table 25-3 indicates the value of read and write parameters in slow clock mode.

Figure 25-28. Read/Write Cycles in Slow Clock Mode

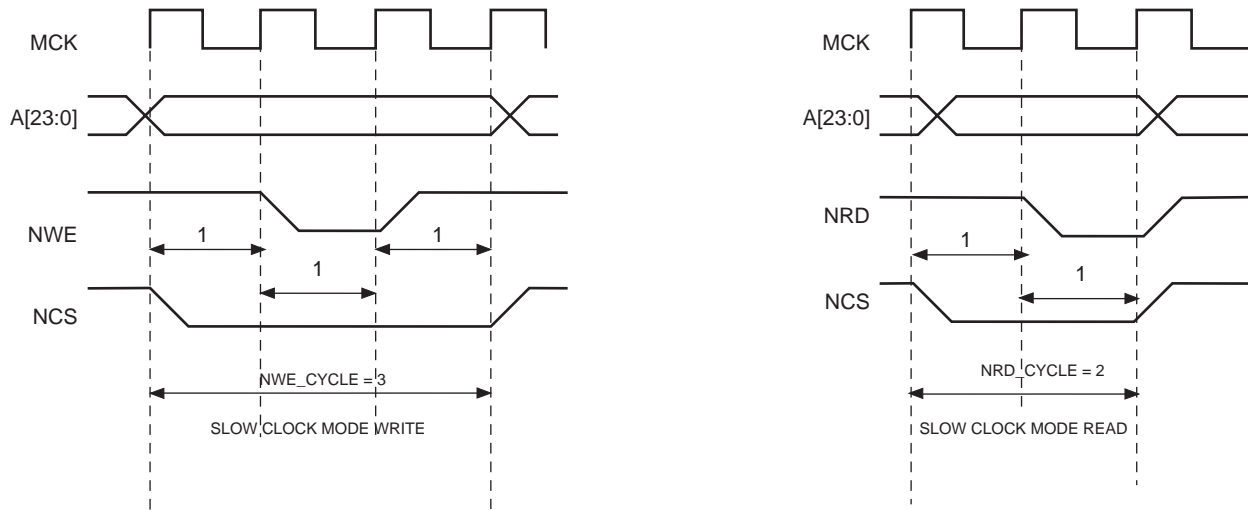

Table 25-3. Read and Write Timing Parameters in Slow Clock Mode

Read Parameters	Duration (cycles)	Write Parameters	Duration (cycles)
NRD_SETUP	1	NWE_SETUP	1
NRD_PULSE	1	NWE_PULSE	1
NCS_RD_SETUP	0	NCS_WR_SETUP	0
NCS_RD_PULSE	2	NCS_WR_PULSE	3
NRD_CYCLE	2	NWE_CYCLE	3

25.13.2 Switching from (to) Slow Clock Mode to (from) Normal Mode

When switching from slow clock mode to the normal mode, the current slow clock mode transfer is completed at high clock rate, with the set of slow clock mode parameters. See Figure 25-29 on page 445. The external device may not be fast enough to support such timings.

Figure 25-30 illustrates the recommended procedure to properly switch from one mode to the other.

Figure 25-29. Clock Rate Transition Occurs while the SMC is Performing a Write Operation

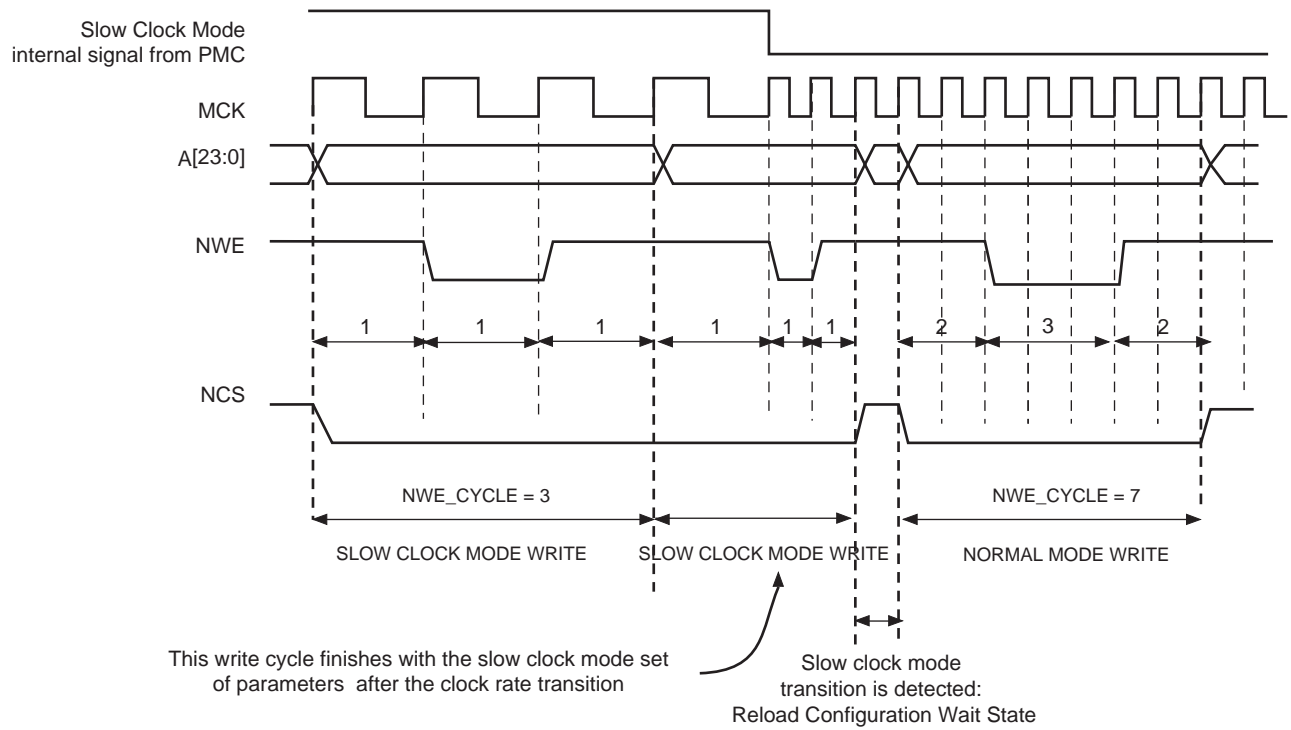
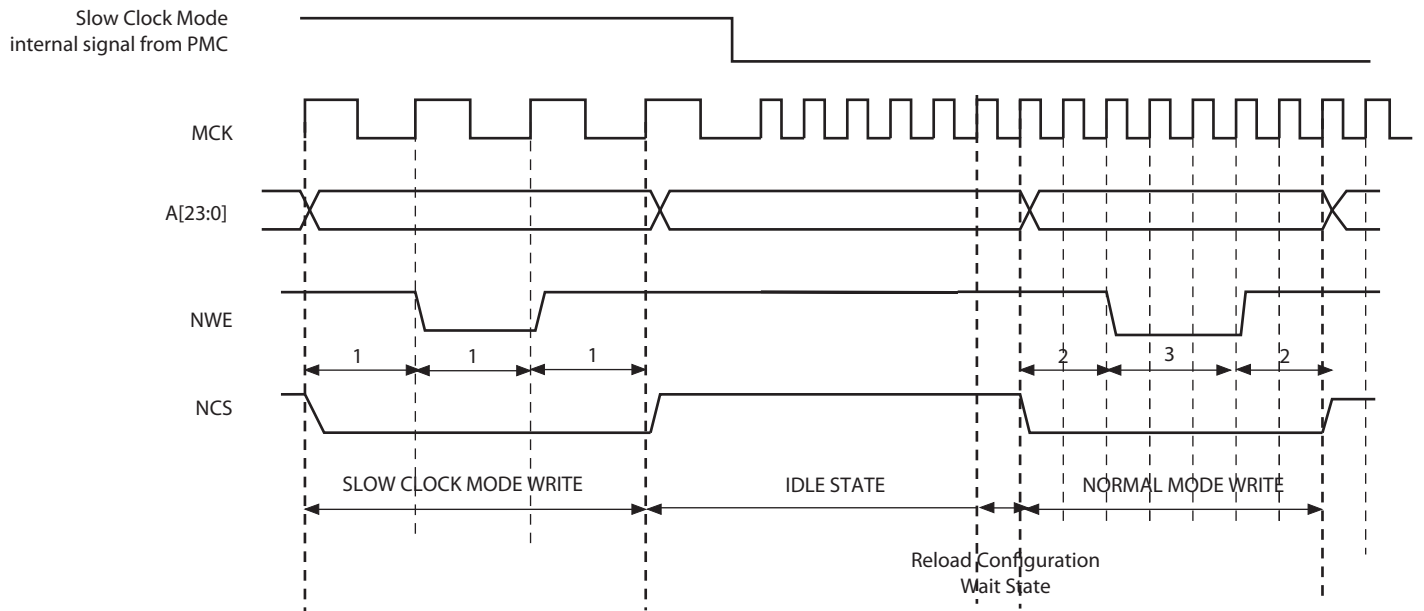

Figure 25-30. Recommended Procedure to Switch from Slow Clock Mode to Normal Mode or from Normal Mode to Slow Clock Mode



25.14 Asynchronous Page Mode

The SMC supports asynchronous burst reads in page mode, providing that the page mode is enabled in the SMC_MODE register (PMEN field). The page size must be configured in the SMC_MODE register (PS field) to 4, 8, 16 or 32 bytes.

The page defines a set of consecutive bytes into memory. A 4-byte page (resp. 8-, 16-, 32-byte page) is always aligned to 4-byte boundaries (resp. 8-, 16-, 32-byte boundaries) of memory. The MSB of data address defines the address of the page in memory, the LSB of address define the address of the data in the page as detailed in [Table 25-4](#).

With page mode memory devices, the first access to one page (t_{pa}) takes longer than the subsequent accesses to the page (t_{sa}) as shown in [Figure 25-31](#). When in page mode, the SMC enables the user to define different read timings for the first access within one page, and next accesses within the page.

Table 25-4. Page Address and Data Address within a Page

Page Size	Page Address ⁽¹⁾	Data Address in the Page
4 bytes	A[23:2]	A[1:0]
8 bytes	A[23:3]	A[2:0]
16 bytes	A[23:4]	A[3:0]
32 bytes	A[23:5]	A[4:0]

Note: 1. "A" denotes the address bus of the memory device.

25.14.1 Protocol and Timings in Page Mode

[Figure 25-31](#) shows the NRD and NCS timings in page mode access.

Figure 25-31. Page Mode Read Protocol (Address MSB and LSB are defined in [Table 25-4](#))

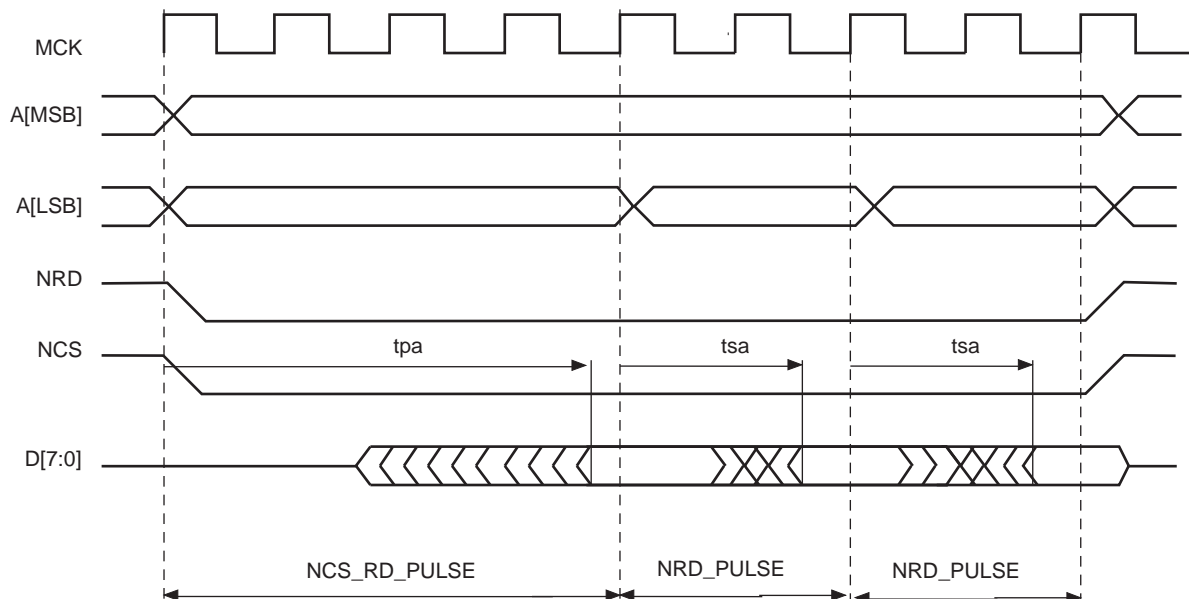

The NRD and NCS signals are held low during all read transfers, whatever the programmed values of the setup and hold timings in the User Interface may be. Moreover, the NRD and NCS timings are identical. The pulse length of the first access to the page is defined with the NCS_RD_PULSE field of the SMC_PULSE register. The pulse length of subsequent accesses within the page are defined using the NRD_PULSE parameter.

In page mode, the programming of the read timings is described in [Table 25-5](#):

Table 25-5. Programming of Read Timings in Page Mode

Parameter	Value	Definition
READ_MODE	'x'	No impact
NCS_RD_SETUP	'x'	No impact
NCS_RD_PULSE	t_{pa}	Access time of first access to the page
NRD_SETUP	'x'	No impact
NRD_PULSE	t_{sa}	Access time of subsequent accesses in the page
NRD_CYCLE	'x'	No impact

The SMC does not check the coherency of timings. It will always apply the NCS_RD_PULSE timings as page access timing (t_{pa}) and the NRD_PULSE for accesses to the page (t_{sa}), even if the programmed value for t_{pa} is shorter than the programmed value for t_{sa} .

25.14.2 Page Mode Restriction

The page mode is not compatible with the use of the NWAIT signal. Using the page mode and the NWAIT signal may lead to unpredictable behavior.

25.14.3 Sequential and Non-sequential Accesses

If the chip select and the MSB of addresses as defined in [Table 25-4](#) are identical, then the current access lies in the same page as the previous one, and no page break occurs.

Using this information, all data within the same page, sequential or not sequential, are accessed with a minimum access time (t_{sa}). [Figure 25-32](#) illustrates access to an 8-bit memory device in page mode, with 8-byte pages. Access to D1 causes a page access with a long access time (t_{pa}). Accesses to D3 and D7, though they are not sequential accesses, only require a short access time (t_{sa}).

If the MSB of addresses are different, the SMC performs the access of a new page. In the same way, if the chip select is different from the previous access, a page break occurs. If two sequential accesses are made to the page mode memory, but separated by an other internal or external peripheral access, a page break occurs on the second access because the chip select of the device was deasserted between both accesses.

Figure 25-32. Access to Non-Sequential Data within the Same Page

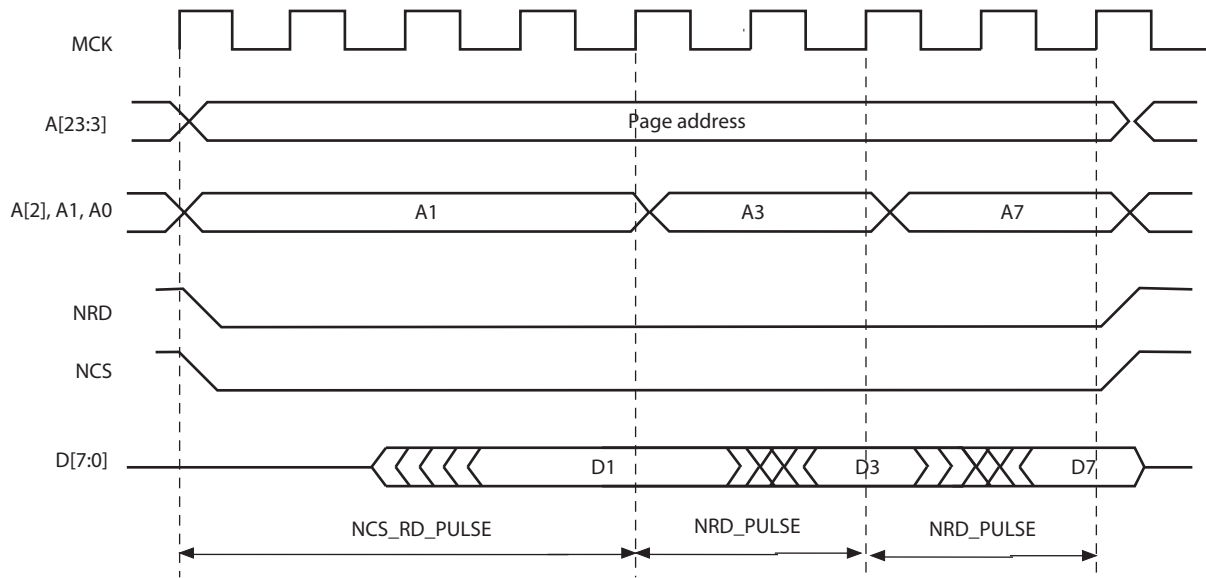

25.15 Static Memory Controller (SMC) User Interface

The SMC is programmed using the registers listed in [Table 25-6](#). For each chip select, a set of 4 registers is used to program the parameters of the external device connected on it. In [Table 25-6](#), “CS_number” denotes the chip select number. 16 bytes (0x10) are required per chip select.

The user must complete writing the configuration by writing any one of the SMC_MODE registers.

Table 25-6. Register Mapping

Offset	Register	Name	Access	Reset
0x10 x CS_number + 0x00	SMC Setup Register	SMC_SETUP	Read-write	0x01010101
0x10 x CS_number + 0x04	SMC Pulse Register	SMC_PULSE	Read-write	0x01010101
0x10 x CS_number + 0x08	SMC Cycle Register	SMC_CYCLE	Read-write	0x00030003
0x10 x CS_number + 0x0C	SMC Mode Register	SMC_MODE	Read-write	0x10000003
0x80	SMC OCMS MODE Register	SMC_OCMS	Read-write	0x00000000
0x84	SMC OCMS KEY1 Register	SMC_KEY1	Write once	0x00000000
0x88	SMC OCMS KEY2 Register	SMC_KEY2	Write once	0x00000000
0xE4	SMC Write Protect Mode Register	SMC_WPMR	Read-write	0x00000000
0xE8	SMC Write Protect Status Register	SMC_WPSR	Read-only	0x00000000
0xEC-0xFC	Reserved	-	-	-

25.15.1 SMC Setup Register

Name: SMC_SETUP[0..3]

Address: 0x400E0000 [0], 0x400E0010 [1], 0x400E0020 [2], 0x400E0030 [3], 0x400E0040 [4]

Access: Read-write

31	30	29	28	27	26	25	24
-	-	NCS_RD_SETUP					
23	22	21	20	19	18	17	16
-	-	NRD_SETUP					
15	14	13	12	11	10	9	8
-	-	NCS_WR_SETUP					
7	6	5	4	3	2	1	0
-	-	NWE_SETUP					

- **NWE_SETUP: NWE Setup Length**

The NWE signal setup length is defined as:

NWE setup length = (128* NWE_SETUP[5] + NWE_SETUP[4:0]) clock cycles

- **NCS_WR_SETUP: NCS Setup Length in WRITE Access**

In write access, the NCS signal setup length is defined as:

NCS setup length = (128* NCS_WR_SETUP[5] + NCS_WR_SETUP[4:0]) clock cycles

- **NRD_SETUP: NRD Setup Length**

The NRD signal setup length is defined in clock cycles as:

NRD setup length = (128* NRD_SETUP[5] + NRD_SETUP[4:0]) clock cycles

- **NCS_RD_SETUP: NCS Setup Length in READ Access**

In read access, the NCS signal setup length is defined as:

NCS setup length = (128* NCS_RD_SETUP[5] + NCS_RD_SETUP[4:0]) clock cycles

25.15.2 SMC Pulse Register

Name: SMC_PULSE[0..3]

Address: 0x400E0004 [0], 0x400E0014 [1], 0x400E0024 [2], 0x400E0034 [3], 0x400E0044 [4]

Access: Read-write

31	30	29	28	27	26	25	24
-	NCS_RD_PULSE						
23	22	21	20	19	18	17	16
-	NRD_PULSE						
15	14	13	12	11	10	9	8
-	NCS_WR_PULSE						
7	6	5	4	3	2	1	0
-	NWE_PULSE						

- **NWE_PULSE: NWE Pulse Length**

The NWE signal pulse length is defined as:

$$\text{NWE pulse length} = (256 * \text{NWE_PULSE}[6] + \text{NWE_PULSE}[5:0]) \text{ clock cycles}$$

The NWE pulse length must be at least 1 clock cycle.

- **NCS_WR_PULSE: NCS Pulse Length in WRITE Access**

In write access, the NCS signal pulse length is defined as:

$$\text{NCS pulse length} = (256 * \text{NCS_WR_PULSE}[6] + \text{NCS_WR_PULSE}[5:0]) \text{ clock cycles}$$

The NCS pulse length must be at least 1 clock cycle.

- **NRD_PULSE: NRD Pulse Length**

In standard read access, the NRD signal pulse length is defined in clock cycles as:

$$\text{NRD pulse length} = (256 * \text{NRD_PULSE}[6] + \text{NRD_PULSE}[5:0]) \text{ clock cycles}$$

The NRD pulse length must be at least 1 clock cycle.

In page mode read access, the NRD_PULSE parameter defines the duration of the subsequent accesses in the page.

- **NCS_RD_PULSE: NCS Pulse Length in READ Access**

In standard read access, the NCS signal pulse length is defined as:

$$\text{NCS pulse length} = (256 * \text{NCS_RD_PULSE}[6] + \text{NCS_RD_PULSE}[5:0]) \text{ clock cycles}$$

The NCS pulse length must be at least 1 clock cycle.

In page mode read access, the NCS_RD_PULSE parameter defines the duration of the first access to one page.

25.15.3 SMC Cycle Register

Name: SMC_CYCLE[0..3]

Address: 0x400E0008 [0], 0x400E0018 [1], 0x400E0028 [2], 0x400E0038 [3], 0x400E0048 [4]

Access: Read-write

31	30	29	28	27	26	25	24
-	-	-	-	-	-	-	NRD_CYCLE
23	22	21	20	19	18	17	16
NRD_CYCLE							
15	14	13	12	11	10	9	8
-	-	-	-	-	-	-	NWE_CYCLE
7	6	5	4	3	2	1	0
NWE_CYCLE							

- **NWE_CYCLE: Total Write Cycle Length**

The total write cycle length is the total duration in clock cycles of the write cycle. It is equal to the sum of the setup, pulse and hold steps of the NWE and NCS signals. It is defined as:

$$\text{Write cycle length} = (\text{NWE_CYCLE}[8:7] * 256 + \text{NWE_CYCLE}[6:0]) \text{ clock cycles}$$

- **NRD_CYCLE: Total Read Cycle Length**

The total read cycle length is the total duration in clock cycles of the read cycle. It is equal to the sum of the setup, pulse and hold steps of the NRD and NCS signals. It is defined as:

$$\text{Read cycle length} = (\text{NRD_CYCLE}[8:7] * 256 + \text{NRD_CYCLE}[6:0]) \text{ clock cycles}$$

25.15.4 SMC MODE Register

Name: SMC_MODE[0..3]

Address: 0x400E000C [0], 0x400E001C [1], 0x400E002C [2], 0x400E003C [3], 0x400E004C [4]

Access: Read-write

31	30	29	28	27	26	25	24
–	–	PS	–	–	–	–	PMEN
23	22	21	20	19	18	17	16
–	–	–	TDF_MODE	TDF_CYCLES			
15	14	13	12	11	10	9	8
–	–	–	–	–	–	–	–
7	6	5	4	3	2	1	0
–	–	EXNW_MODE	–	–	WRITE_MODE	READ_MODE	–

• READ_MODE:

1: The read operation is controlled by the NRD signal.

- If TDF cycles are programmed, the external bus is marked busy after the rising edge of NRD.
- If TDF optimization is enabled (TDF_MODE =1), TDF wait states are inserted after the setup of NRD.

0: The read operation is controlled by the NCS signal.

- If TDF cycles are programmed, the external bus is marked busy after the rising edge of NCS.
- If TDF optimization is enabled (TDF_MODE =1), TDF wait states are inserted after the setup of NCS.

• WRITE_MODE

1: The write operation is controlled by the NWE signal.

- If TDF optimization is enabled (TDF_MODE =1), TDF wait states will be inserted after the setup of NWE.

0: The write operation is controlled by the NCS signal.

- If TDF optimization is enabled (TDF_MODE =1), TDF wait states will be inserted after the setup of NCS.

• EXNW_MODE: NWAIT Mode

The NWAIT signal is used to extend the current read or write signal. It is only taken into account during the pulse phase of the read and write controlling signal. When the use of NWAIT is enabled, at least one cycle hold duration must be programmed for the read and write controlling signal.

Value	Name	Description
0	DISABLED	Disabled
1		Reserved
2	FROZEN	Frozen Mode
3	READY	Ready Mode

- Disabled Mode: The NWAIT input signal is ignored on the corresponding Chip Select.
- Frozen Mode: If asserted, the NWAIT signal freezes the current read or write cycle. After deassertion, the read/write cycle is resumed from the point where it was stopped.

- **Ready Mode:** The NWAIT signal indicates the availability of the external device at the end of the pulse of the controlling read or write signal, to complete the access. If high, the access normally completes. If low, the access is extended until NWAIT returns high.

- **TDF_CYCLES: Data Float Time**

This field gives the integer number of clock cycles required by the external device to release the data after the rising edge of the read controlling signal. The SMC always provide one full cycle of bus turnaround after the TDF_CYCLES period. The external bus cannot be used by another chip select during TDF_CYCLES + 1 cycles. From 0 up to 15 TDF_CYCLES can be set.

- **TDF_MODE: TDF Optimization**

1: TDF optimization is enabled.

- The number of TDF wait states is optimized using the setup period of the next read/write access.

0: TDF optimization is disabled.

- The number of TDF wait states is inserted before the next access begins.

- **PMEN: Page Mode Enabled**

1: Asynchronous burst read in page mode is applied on the corresponding chip select.

0: Standard read is applied.

- **PS: Page Size**

If page mode is enabled, this field indicates the size of the page in bytes.

Value	Name	Description
0	4_BYTE	4-byte page
1	8_BYTE	8-byte page
2	16_BYTE	16-byte page
3	32_BYTE	32-byte page

25.15.5 SMC OCMS Mode Register

Name: SMC_OCMS

Address: 0x400E0080

Access: Read-write

Reset: 0x00000000

31	30	29	28	27	26	25	24
–	–	–	–	–	–	–	–
23	22	21	20	19	18	17	16
–	–	–	–	CS3SE	CS2SE	CS1SE	CS0SE
15	14	13	12	11	10	9	8
–	–	–	–	–	–	–	–
7	6	5	4	3	2	1	0
–	–	–	–	–	–	–	SMSE

- **CSxSE: Chip Select (x = 0 to 3) Scrambling Enable**

0: Disable Scrambling for CSx.

1: Enable Scrambling for CSx.

- **SMSE: Static Memory Controller Scrambling Enable**

0: Disable Scrambling for SMC access.

1: Enable Scrambling for SMC access.

25.15.6 SMC OCMS Key1 Register

Name: SMC_KEY1

Address: 0x400E0084

Access: Write Once

Reset: 0x00000000

31	30	29	28	27	26	25	24
KEY1							
23	22	21	20	19	18	17	16
KEY1							
15	14	13	12	11	10	9	8
KEY1							
7	6	5	4	3	2	1	0
KEY1							

- **KEY1: Off Chip Memory Scrambling (OCMS) Key Part 1**

When Off Chip Memory Scrambling is enabled setting the SMC_OCMS and SMC_TIMINGS registers in accordance, the data scrambling depends on KEY1 and KEY2 values.

25.15.7 SMC OCMS Key2 Register

Name: SMC_KEY2

Address: 0x400E0088

Access: Write Once

Reset: 0x00000000

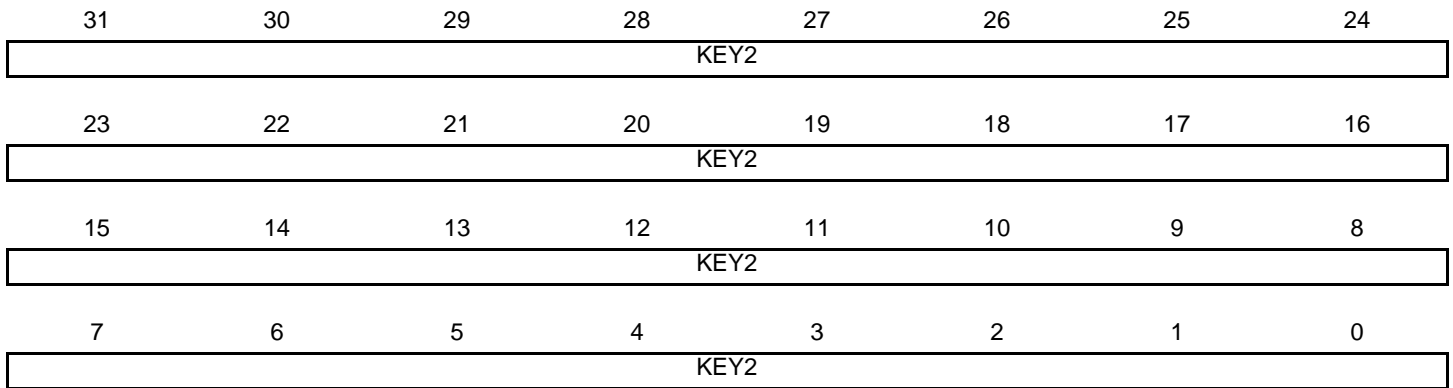

- **KEY2: Off Chip Memory Scrambling (OCMS) Key Part 2**

When Off Chip Memory Scrambling is enabled setting the SMC_OCMS and SMC_TIMINGS registers in accordance, the data scrambling depends on KEY2 and KEY1 values.

25.15.8 SMC Write Protect Mode Register

Name: SMC_WPMR
Address: 0x400E00E4
Access: Read-write
Reset: See [Table 25-6](#)

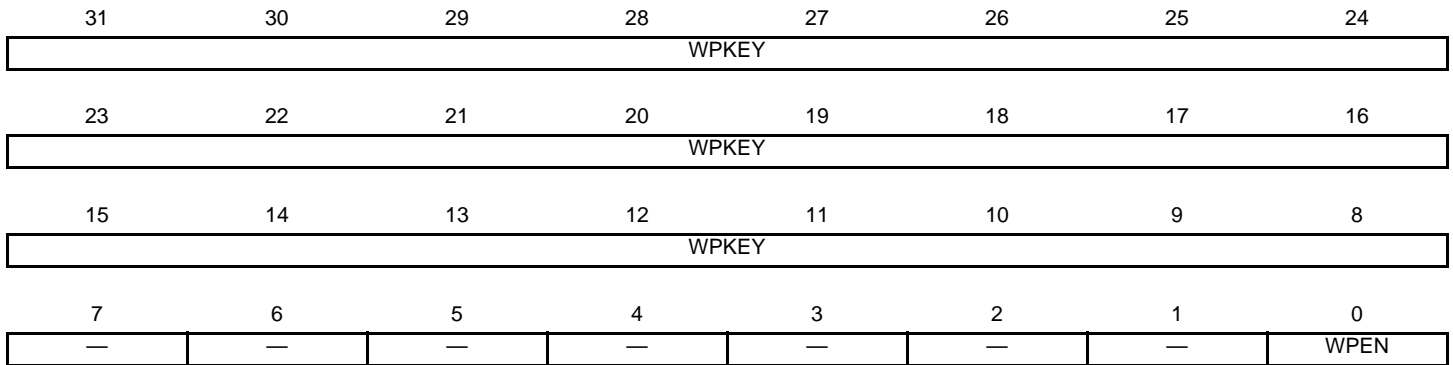

- **WPEN: Write Protect Enable**

0 = Disables the Write Protect if WPKEY corresponds to 0x534D43 (“SMC” in ASCII).

1 = Enables the Write Protect if WPKEY corresponds to 0x534D43 (“SMC” in ASCII).

Protects the registers listed below:

- [Section 25.15.1 “SMC Setup Register”](#)
- [Section 25.15.2 “SMC Pulse Register”](#)
- [Section 25.15.3 “SMC Cycle Register”](#)
- [Section 25.15.4 “SMC MODE Register”](#)

- **WPKEY: Write Protect KEY**

Should be written at value 0x534D43 (“SMC” in ASCII). Writing any other value in this field aborts the write operation of the WPEN bit. Always reads as 0.

25.15.9 SMC Write Protect Status Register

Name: SMC_WPSR

Address: 0x400E00E8

Type: Read-only

Value: See [Table 25-6](#)

31	30	29	28	27	26	25	24
—	—	—	—	—	—	—	—
23	22	21	20	19	18	17	16
WPVSR							
15	14	13	12	11	10	9	8
WPVSR							
7	6	5	4	3	2	1	0
—	—	—	—	—	—	—	WPVS

- **WPVS: Write Protect Enable**

0 = No Write Protect Violation has occurred since the last read of the SMC_WPSR register.

1 = A Write Protect Violation occurred since the last read of the SMC_WPSR register. If this violation is an unauthorized attempt to write a protected register, the associated violation is reported into field WPVSR.

- **WPVSR: Write Protect Violation Source**

When WPVS is active, this field indicates the write-protected register (through address offset or code) in which a write access has been attempted.

Note: Reading SMC_WPSR automatically clears all fields.

26. Peripheral DMA Controller (PDC)

26.1 Description

The Peripheral DMA Controller (PDC) transfers data between on-chip serial peripherals and the on- and/or off-chip memories. The link between the PDC and a serial peripheral is operated by the AHB to ABP bridge.

The user interface of each PDC channel is integrated into the user interface of the peripheral it serves. The user interface of mono directional channels (receive only or transmit only), contains two 32-bit memory pointers and two 16-bit counters, one set (pointer, counter) for current transfer and one set (pointer, counter) for next transfer. The bi-directional channel user interface contains four 32-bit memory pointers and four 16-bit counters. Each set (pointer, counter) is used by current transmit, next transmit, current receive and next receive.

Using the PDC removes processor overhead by reducing its intervention during the transfer. This significantly reduces the number of clock cycles required for a data transfer, which improves microcontroller performance.

To launch a transfer, the peripheral triggers its associated PDC channels by using transmit and receive signals. When the programmed data is transferred, an end of transfer interrupt is generated by the peripheral itself.

26.2 Embedded Characteristics

- Handles data transfer between peripherals and memories
- Low bus arbitration overhead
 - One Master Clock cycle needed for a transfer from memory to peripheral
 - Two Master Clock cycles needed for a transfer from peripheral to memory
- Next Pointer management for reducing interrupt latency requirement

The Peripheral DMA Controller handles transfer requests from the channel according to the following priorities (Low to High priorities):

Table 26-1. Peripheral DMA Controller

Instance Name	Channel T/R
PWM	Transmit
TWI1	Transmit
TWI0	Transmit
UART1	Transmit
UART0	Transmit
USART1	Transmit
USART0	Transmit
DACC	Transmit
SPI	Transmit
SSC	Transmit
HSMCI	Transmit

Table 26-1. Peripheral DMA Controller

Instance Name	Channel T/R
PIOA	Receive
TWI1	Receive
TWI0	Receive
UART1	Receive
UART0	Receive
USART1	Receive
USART0	Receive
ADC	Receive
SPI	Receive
SSC	Receive
HSMCI	Receive

26.3 Block Diagram

Figure 26-1. Block Diagram

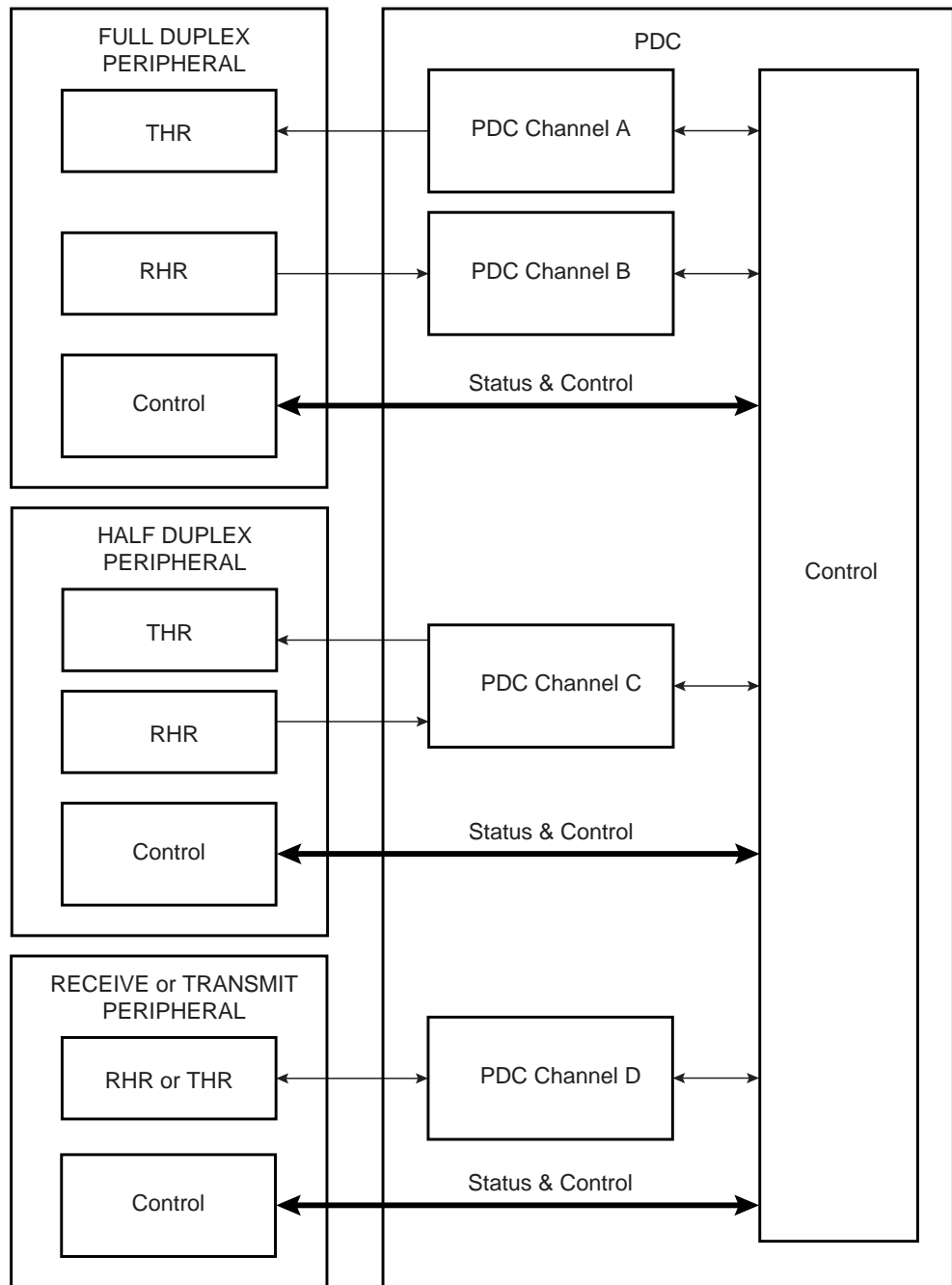

26.4 Functional Description

26.4.1 Configuration

The PDC channel user interface enables the user to configure and control data transfers for each channel. The user interface of each PDC channel is integrated into the associated peripheral user interface.

The user interface of a serial peripheral, whether it is full or half duplex, contains four 32-bit pointers (RPR, RNPR, TPR, TNPR) and four 16-bit counter registers (RCR, RNCR, TCR, TNCR). However, the transmit and receive parts of each type are programmed differently: the transmit and receive parts of a full duplex peripheral can be programmed at the same time, whereas only one part (transmit or receive) of a half duplex peripheral can be programmed at a time.

32-bit pointers define the access location in memory for current and next transfer, whether it is for read (transmit) or write (receive). 16-bit counters define the size of current and next transfers. It is possible, at any moment, to read the number of transfers left for each channel.

The PDC has dedicated status registers which indicate if the transfer is enabled or disabled for each channel. The status for each channel is located in the associated peripheral status register. Transfers can be enabled and/or disabled by setting TXTEN/TXTDIS and RXTEN/RXTDIS in the peripheral's Transfer Control Register.

At the end of a transfer, the PDC channel sends status flags to its associated peripheral. These flags are visible in the peripheral status register (ENDRX, ENDTX, RXBUFF, and TXBUFE). Refer to [Section 26.4.3](#) and to the associated peripheral user interface.

26.4.2 Memory Pointers

Each full duplex peripheral is connected to the PDC by a receive channel and a transmit channel. Both channels have 32-bit memory pointers that point respectively to a receive area and to a transmit area in on- and/or off-chip memory.

Each half duplex peripheral is connected to the PDC by a bidirectional channel. This channel has two 32-bit memory pointers, one for current transfer and the other for next transfer. These pointers point to transmit or receive data depending on the operating mode of the peripheral.

Depending on the type of transfer (byte, half-word or word), the memory pointer is incremented respectively by 1, 2 or 4 bytes.

If a memory pointer address changes in the middle of a transfer, the PDC channel continues operating using the new address.

26.4.3 Transfer Counters

Each channel has two 16-bit counters, one for current transfer and the other one for next transfer. These counters define the size of data to be transferred by the channel. The current transfer counter is decremented first as the data addressed by current memory pointer starts to be transferred. When the current transfer counter reaches zero, the channel checks its next transfer counter. If the value of next counter is zero, the channel stops transferring data and sets the appropriate flag. But if the next counter value is greater than zero, the values of the next pointer/next counter are copied into the current pointer/current counter and the channel resumes the transfer whereas next pointer/next counter get zero/zero as values. At the end of this transfer the PDC channel sets the appropriate flags in the Peripheral Status Register.

The following list gives an overview of how status register flags behave depending on the counters' values:

- ENDRX flag is set when the PERIPH_RCR register reaches zero.
- RXBUFF flag is set when both PERIPH_RCR and PERIPH_RNCR reach zero.
- ENDTX flag is set when the PERIPH_TCR register reaches zero.
- TXBUFE flag is set when both PERIPH_TCR and PERIPH_TNCR reach zero.

These status flags are described in the Peripheral Status Register.

26.4.4 Data Transfers

The serial peripheral triggers its associated PDC channels' transfers using transmit enable (TXEN) and receive enable (RXEN) flags in the transfer control register integrated in the peripheral's user interface.

When the peripheral receives an external data, it sends a Receive Ready signal to its PDC receive channel which then requests access to the Matrix. When access is granted, the PDC receive channel starts reading the peripheral Receive Holding Register (RHR). The read data are stored in an internal buffer and then written to memory.

When the peripheral is about to send data, it sends a Transmit Ready to its PDC transmit channel which then requests access to the Matrix. When access is granted, the PDC transmit channel reads data from memory and puts them to Transmit Holding Register (THR) of its associated peripheral. The same peripheral sends data according to its mechanism.

26.4.5 PDC Flags and Peripheral Status Register

Each peripheral connected to the PDC sends out receive ready and transmit ready flags and the PDC sends back flags to the peripheral. All these flags are only visible in the Peripheral Status Register.

Depending on the type of peripheral, half or full duplex, the flags belong to either one single channel or two different channels.

26.4.5.1 *Receive Transfer End*

This flag is set when PERIPH_RCR register reaches zero and the last data has been transferred to memory.

It is reset by writing a non zero value in PERIPH_RCR or PERIPH_RNCR.

26.4.5.2 *Transmit Transfer End*

This flag is set when PERIPH_TCR register reaches zero and the last data has been written into peripheral THR.

It is reset by writing a non zero value in PERIPH_TCR or PERIPH_TNCR.

26.4.5.3 *Receive Buffer Full*

This flag is set when PERIPH_RCR register reaches zero with PERIPH_RNCR also set to zero and the last data has been transferred to memory.

It is reset by writing a non zero value in PERIPH_TCR or PERIPH_TNCR.

26.4.5.4 *Transmit Buffer Empty*

This flag is set when PERIPH_TCR register reaches zero with PERIPH_TNCR also set to zero and the last data has been written into peripheral THR.

It is reset by writing a non zero value in PERIPH_TCR or PERIPH_TNCR.

26.5 Peripheral DMA Controller (PDC) User Interface

Table 26-2. Register Mapping

Offset	Register	Name	Access	Reset
0x100	Receive Pointer Register	PERIPH ⁽¹⁾ _RPR	Read-write	0
0x104	Receive Counter Register	PERIPH_RCR	Read-write	0
0x108	Transmit Pointer Register	PERIPH_TPR	Read-write	0
0x10C	Transmit Counter Register	PERIPH_TCR	Read-write	0
0x110	Receive Next Pointer Register	PERIPH_RNPR	Read-write	0
0x114	Receive Next Counter Register	PERIPH_RNCR	Read-write	0
0x118	Transmit Next Pointer Register	PERIPH_TNPR	Read-write	0
0x11C	Transmit Next Counter Register	PERIPH_TNCR	Read-write	0
0x120	Transfer Control Register	PERIPH_PTCR	Write-only	0
0x124	Transfer Status Register	PERIPH_PTSR	Read-only	0

Note: 1. PERIPH: Ten registers are mapped in the peripheral memory space at the same offset. These can be defined by the user according to the function and the desired peripheral.)

26.5.1 Receive Pointer Register

Name: PERIPH_RPR

Access: Read-write

31	30	29	28	27	26	25	24
RXPTR							
23	22	21	20	19	18	17	16
RXPTR							
15	14	13	12	11	10	9	8
RXPTR							
7	6	5	4	3	2	1	0
RXPTR							

- **RXPTR: Receive Pointer Register**

RXPTR must be set to receive buffer address.

When a half duplex peripheral is connected to the PDC, RXPTR = TXPTR.

26.5.2 Receive Counter Register

Name: PERIPH_RCR

Access: Read-write

31	30	29	28	27	26	25	24
–	–	–	–	–	–	–	–
23	22	21	20	19	18	17	16
–	–	–	–	–	–	–	–
15	14	13	12	11	10	9	8
RXCTR							
7	6	5	4	3	2	1	0
RXCTR							

- **RXCTR: Receive Counter Register**

RXCTR must be set to receive buffer size.

When a half duplex peripheral is connected to the PDC, RXCTR = TXCTR.

0 = Stops peripheral data transfer to the receiver

1 - 65535 = Starts peripheral data transfer if corresponding channel is active

26.5.3 Transmit Pointer Register

Name: PERIPH_TPR

Access: Read-write

31	30	29	28	27	26	25	24
TXPTR							
23	22	21	20	19	18	17	16
TXPTR							
15	14	13	12	11	10	9	8
TXPTR							
7	6	5	4	3	2	1	0
TXPTR							

- **TXPTR: Transmit Counter Register**

TXPTR must be set to transmit buffer address.

When a half duplex peripheral is connected to the PDC, RXPTR = TXPTR.

26.5.4 Transmit Counter Register

Name: PERIPH_TCR

Access: Read-write

31	30	29	28	27	26	25	24
–	–	–	–	–	–	–	–
23	22	21	20	19	18	17	16
–	–	–	–	–	–	–	–
15	14	13	12	11	10	9	8
TXCTR							
7	6	5	4	3	2	1	0
TXCTR							

- **TXCTR: Transmit Counter Register**

TXCTR must be set to transmit buffer size.

When a half duplex peripheral is connected to the PDC, RXCTR = TXCTR.

0 = Stops peripheral data transfer to the transmitter

1- 65535 = Starts peripheral data transfer if corresponding channel is active

26.5.5 Receive Next Pointer Register

Name: PERIPH_RNPR

Access: Read-write

31	30	29	28	27	26	25	24
RXNPTR							
23	22	21	20	19	18	17	16
RXNPTR							
15	14	13	12	11	10	9	8
RXNPTR							
7	6	5	4	3	2	1	0
RXNPTR							

- **RXNPTR: Receive Next Pointer**

RXNPTR contains next receive buffer address.

When a half duplex peripheral is connected to the PDC, RXNPTR = TXNPTR.

26.5.6 Receive Next Counter Register

Name: PERIPH_RNCR

Access: Read-write

31	30	29	28	27	26	25	24
–	–	–	–	–	–	–	–
23	22	21	20	19	18	17	16
–	–	–	–	–	–	–	–
15	14	13	12	11	10	9	8
RXNCTR							
7	6	5	4	3	2	1	0
RXNCTR							

- **RXNCTR: Receive Next Counter**

RXNCTR contains next receive buffer size.

When a half duplex peripheral is connected to the PDC, RXNCTR = TXNCTR.

26.5.7 Transmit Next Pointer Register

Name: PERIPH_TNPR

Access: Read-write

31	30	29	28	27	26	25	24
TXNPTR							
23	22	21	20	19	18	17	16
TXNPTR							
15	14	13	12	11	10	9	8
TXNPTR							
7	6	5	4	3	2	1	0
TXNPTR							

- **TXNPTR: Transmit Next Pointer**

TXNPTR contains next transmit buffer address.

When a half duplex peripheral is connected to the PDC, RXNPTR = TXNPTR.

26.5.8 Transmit Next Counter Register

Name: PERIPH_TNCR

Access: Read-write

31	30	29	28	27	26	25	24
–	–	–	–	–	–	–	–
23	22	21	20	19	18	17	16
–	–	–	–	–	–	–	–
15	14	13	12	11	10	9	8
TXNCTR							
7	6	5	4	3	2	1	0
TXNCTR							

- **TXNCTR: Transmit Counter Next**

TXNCTR contains next transmit buffer size.

When a half duplex peripheral is connected to the PDC, RXNCTR = TXNCTR.

26.5.9 Transfer Control Register

Name: PERIPH_PTCR

Access: Write-only

31	30	29	28	27	26	25	24
–	–	–	–	–	–	–	–
23	22	21	20	19	18	17	16
–	–	–	–	–	–	–	–
15	14	13	12	11	10	9	8
–	–	–	–	–	–	TXTDIS	TXTEN
7	6	5	4	3	2	1	0
–	–	–	–	–	–	RXTDIS	RXTEN

- **RXTEN: Receiver Transfer Enable**

0 = No effect.

1 = Enables PDC receiver channel requests if RXTDIS is not set.

When a half duplex peripheral is connected to the PDC, enabling the receiver channel requests automatically disables the transmitter channel requests. It is forbidden to set both TXTEN and RXTEN for a half duplex peripheral.

- **RXTDIS: Receiver Transfer Disable**

0 = No effect.

1 = Disables the PDC receiver channel requests.

When a half duplex peripheral is connected to the PDC, disabling the receiver channel requests also disables the transmitter channel requests.

- **TXTEN: Transmitter Transfer Enable**

0 = No effect.

1 = Enables the PDC transmitter channel requests.

When a half duplex peripheral is connected to the PDC, it enables the transmitter channel requests only if RXTEN is not set. It is forbidden to set both TXTEN and RXTEN for a half duplex peripheral.

- **TXTDIS: Transmitter Transfer Disable**

0 = No effect.

1 = Disables the PDC transmitter channel requests.

When a half duplex peripheral is connected to the PDC, disabling the transmitter channel requests disables the receiver channel requests.

26.5.10 Transfer Status Register

Name: PERIPH_PTSR

Access: Read-only

31	30	29	28	27	26	25	24
–	–	–	–	–	–	–	–
23	22	21	20	19	18	17	16
–	–	–	–	–	–	–	–
15	14	13	12	11	10	9	8
–	–	–	–	–	–	–	TXTEN
7	6	5	4	3	2	1	0
–	–	–	–	–	–	–	RXTEN

- **RXTEN: Receiver Transfer Enable**

0 = PDC Receiver channel requests are disabled.

1 = PDC Receiver channel requests are enabled.

- **TXTEN: Transmitter Transfer Enable**

0 = PDC Transmitter channel requests are disabled.

1 = PDC Transmitter channel requests are enabled.

27. Power Management Controller (PMC)

27.1 Clock Generator

27.1.1 Description

The Clock Generator User Interface is embedded within the Power Management Controller and is described in [Section 27.2.16 "Power Management Controller \(PMC\) User Interface"](#). However, the Clock Generator registers are named CKGR_.

27.1.2 Embedded Characteristics

The Clock Generator is made up of:

- A Low Power 32,768 Hz Slow Clock Oscillator with bypass mode.
- A Low Power RC Oscillator
- A 3 to 20 MHz Crystal or Ceramic Resonator-based Oscillator, which can be bypassed.
- A factory programmed Fast RC Oscillator. 3 output frequencies can be selected: 4, 8 or 12 MHz. By default 4MHz is selected.
- Two 80 to 240 MHz programmable PLL (input from 3 to 32 MHz), capable of providing the clock MCK to the processor and to the peripherals.

It provides the following clocks:

- SLCK, the Slow Clock, which is the only permanent clock within the system.
- MAINCK is the output of the Main Clock Oscillator selection: either the Crystal or Ceramic Resonator-based Oscillator or 4/8/12 MHz Fast RC Oscillator.
- PLLACK is the output of the Divider and 80 to 240 MHz programmable PLL (PLLA).
- PLLBCK is the output of the Divider and 80 to 240 MHz programmable PLL (PLLB).

27.1.3 Block Diagram

Figure 27-1. Clock Generator Block Diagram

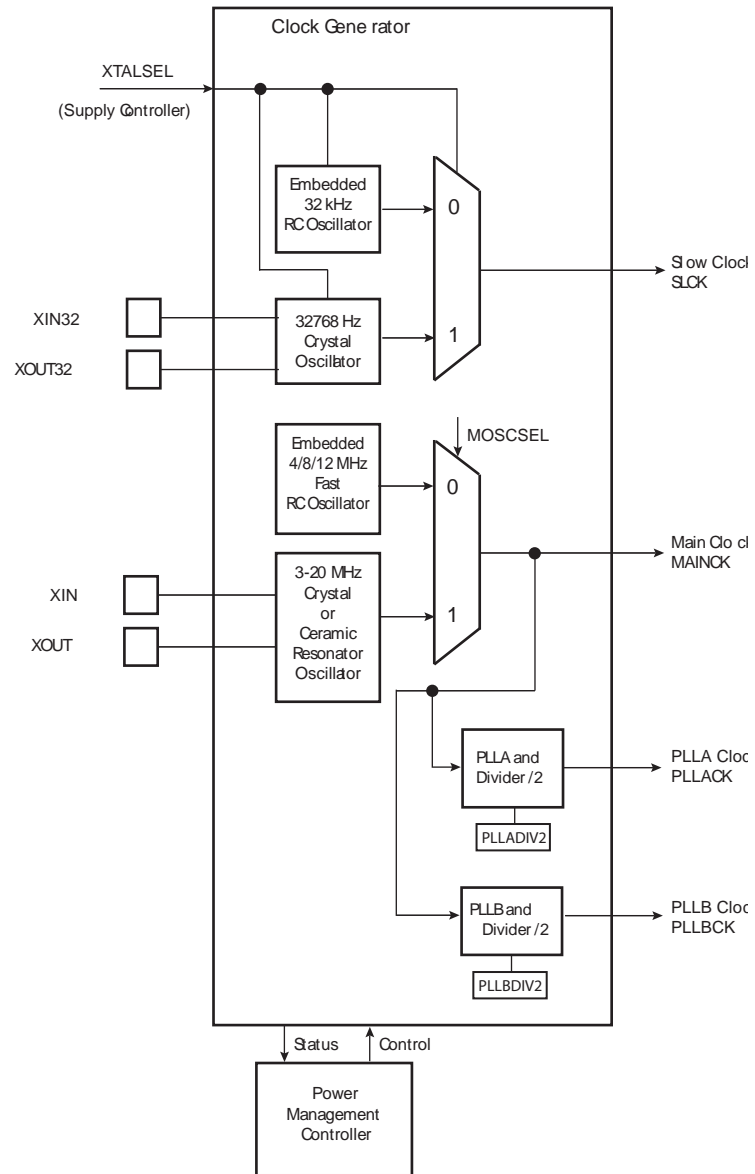

27.1.4 Slow Clock

The Supply Controller embeds a slow clock generator that is supplied with the VDDIO power supply. As soon as the VDDIO is supplied, both the crystal oscillator and the embedded RC oscillator are powered up, but only the embedded RC oscillator is enabled. This allows the slow clock to be valid in a short time (about 100 μ s).

The Slow Clock is generated either by the Slow Clock Crystal Oscillator or by the Slow Clock RC Oscillator.

The selection between the RC or the crystal oscillator is made by writing the XTALSEL bit in the Supply Controller Control Register (SUPC_CR).

27.1.4.1 Slow Clock RC Oscillator

By default, the Slow Clock RC Oscillator is enabled and selected. The user has to take into account the possible drifts of the RC Oscillator. More details are given in the section “DC Characteristics” of the product datasheet.

It can be disabled via the XTALSEL bit in the Supply Controller Control Register (SUPC_CR).

27.1.4.2 Slow Clock Crystal Oscillator

The Clock Generator integrates a 32,768 Hz low-power oscillator. In order to use this oscillator, the XIN32 and XOUT32 pins must be connected to a 32,768 Hz crystal. Two external capacitors must be wired as shown in [Figure 27-2](#). More details are given in the section “DC Characteristics” of the product datasheet.

Note that the user is not obliged to use the Slow Clock Crystal and can use the RC oscillator instead.

Figure 27-2. Typical Slow Clock Crystal Oscillator Connection

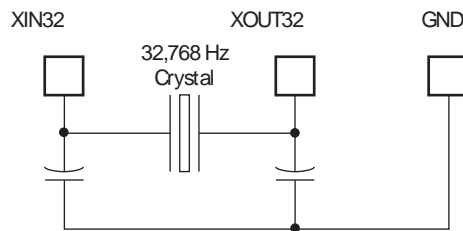

The user can select the crystal oscillator to be the source of the slow clock, as it provides a more accurate frequency. The command is made by writing the Supply Controller Control Register (SUPC_CR) with the XTALSEL bit at 1. This results in a sequence which first configures the PIO lines multiplexed with XIN32 and XOUT32 to be driven by the oscillator, then enables the crystal oscillator and then disables the RC oscillator to save power. The switch of the slow clock source is glitch free. The OSCSEL bit of the Supply Controller Status Register (SUPC_SR) tracks the oscillator frequency downstream. It must be read in order to be informed when the switch sequence, initiated when a new value is written in MOSCSEL bit of CKGR_MOR, is done.

Coming back on the RC oscillator is only possible by shutting down the VDDIO power supply. If the user does not need the crystal oscillator, the XIN32 and XOUT32 pins can be left unconnected since by default the XIN32 and XOUT32 system I/O pins are in PIO input mode with pull-up after reset.

The user can also set the crystal oscillator in bypass mode instead of connecting a crystal. In this case, the user has to provide the external clock signal on XIN32. The input characteristics of

the XIN32 pin are given in the product electrical characteristics section. In order to set the bypass mode, the OSCBYPASS bit of the Supply Controller Mode Register (SUPC_MR) needs to be set at 1.

The user can set the Slow Clock Crystal Oscillator in bypass mode instead of connecting a crystal. In this case, the user has to provide the external clock signal on XIN32. The input characteristics of the XIN32 pin under these conditions are given in the product electrical characteristics section.

The programmer has to be sure to set the OSCBYPASS bit in the Supply Controller Mode Register (SUPC_MR) and XTALSEL bit in the Supply Controller Control Register (SUPC_CR).

27.1.5 Main Clock

Figure 27-3 shows the Main Clock block diagram.

Figure 27-3. Main Clock Block Diagram

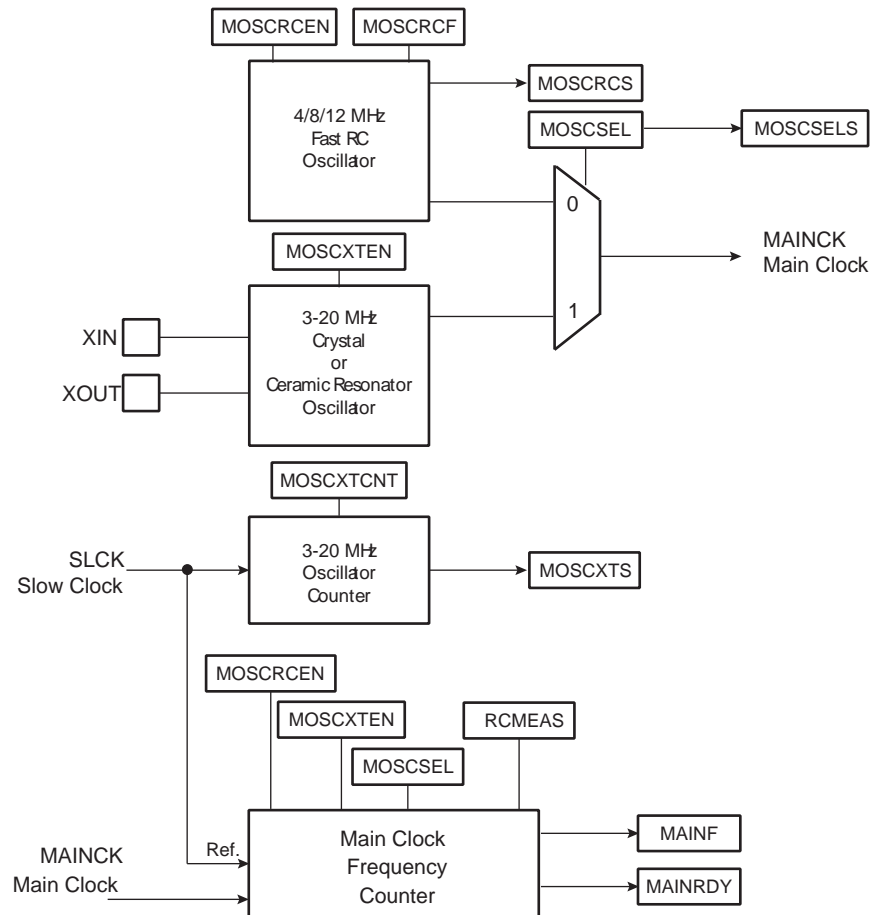

The Main Clock has two sources:

- 4/8/12 MHz Fast RC Oscillator which starts very quickly and is used at startup.
- 3 to 20 MHz Crystal or Ceramic Resonator-based Oscillator which can be bypassed.

27.1.5.1 4/8/12 MHz Fast RC Oscillator

After reset, the 4/8/12 MHz Fast RC Oscillator is enabled with the 4 MHz frequency selected and it is selected as the source of MAINCK. MAINCK is the default clock selected to start up the system.

The Fast RC Oscillator 8 and 12 MHz frequencies are calibrated in production. Note that is not the case for the 4 MHz frequency.

Please refer to the “DC Characteristics” section of the product datasheet.

The software can disable or enable the 4/8/12 MHz Fast RC Oscillator with the MOSCRGEN bit in the Clock Generator Main Oscillator Register (CKGR_MOR).

The user can also select the output frequency of the Fast RC Oscillator, either 4 MHz, 8 MHz or 12 MHz are available. It can be done through MOSCRCF bits in CKGR_MOR. When changing this frequency selection, the MOSCRCS bit in the Power Management Controller Status Register (PMC_SR) is automatically cleared and MAINCK is stopped until the oscillator is stabilized. Once the oscillator is stabilized, MAINCK restarts and MOSCRCS is set.

When disabling the Main Clock by clearing the MOSCRGEN bit in CKGR_MOR, the MOSCRCS bit in the Power Management Controller Status Register (PMC_SR) is automatically cleared, indicating the Main Clock is off.

Setting the MOSCRCS bit in the Power Management Controller Interrupt Enable Register (PMC_IER) can trigger an interrupt to the processor.

It is recommended to disable the Main Clock as soon as the processor no longer uses it and runs out of SLCK, PLLACK or PLLBCK.

The CAL4, CAL8 and CAL12 values in the PMC Oscillator Calibration Register (PMC_OCR) are the default values set by Atmel during production. These values are stored in a specific Flash memory area different from the main memory plane. These values cannot be modified by the user and cannot be erased by a Flash erase command or by the ERASE pin. Values written by the user's application in PMC_OCR are reset after each power up or peripheral reset.

27.1.5.2 4/8/12 MHz Fast RC Oscillator Clock Frequency Adjustment

It is possible for the user to adjust the main RC oscillator frequency through PMC_OCR. By default, SEL4/8/12 are low, so the RC oscillator will be driven with Flash calibration bits which are programmed during chip production.

The user can adjust the trimming of the 4/8/12 MHz Fast RC oscillator through this register in order to obtain more accurate frequency (to compensate derating factors such as temperature and voltage).

In order to calibrate the 4 MHz oscillator frequency, SEL4 must be set to 1 and a good frequency value must be configured in CAL4. Likewise, SEL8/12 must be set to 1 and a trim value must be configured in CAL8/12 in order to adjust the 8/12 MHz frequency oscillator.

It is possible to adjust the oscillator frequency while operating from this clock. For example, when running on 4 MHz it is possible to change the CAL4 value if SEL4 is set in PMC_OCR.

It is possible to restart, at anytime, a measurement of the main frequency by means of the RCMEAS bit in Main Clock Frequency Register (CKGR_MCFR). Thus, when MAINFRDY flag is set, the MAINF field returns the frequency of the main clock and software can calculate the error with an expected frequency and correct the CAL4 (or CAL8/CAL12) field accordingly. This may be used to compensate frequency drift due to derating factors such as temperature and/or voltage.

27.1.5.3 3 to 20 MHz Crystal or Ceramic Resonator-based Oscillator

After reset, the 3 to 20 MHz Crystal or Ceramic Resonator-based oscillator is disabled and it is not selected as the source of MAINCK.

The user can select the 3 to 20 MHz Crystal or Ceramic Resonator-based oscillator to be the source of MAINCK, as it provides a more accurate frequency. The software enables or disables the main oscillator so as to reduce power consumption by clearing the MOSCXTEN bit in the Main Oscillator Register (CKGR_MOR).

When disabling the main oscillator by clearing the MOSCXTEN bit in CKGR_MOR, the MOSCXTS bit in PMC_SR is automatically cleared, indicating the Main Clock is off.

When enabling the main oscillator, the user must initiate the main oscillator counter with a value corresponding to the startup time of the oscillator. This startup time depends on the crystal frequency connected to the oscillator.

When the MOSCXTEN bit and the MOSCXCNT are written in CKGR_MOR to enable the main oscillator, the XIN and XOUT pins are automatically switched into oscillator mode and MOSCXTS bit in the Power Management Controller Status Register (PMC_SR) is cleared and the counter starts counting down on the slow clock divided by 8 from the MOSCXCNT value. Since the MOSCXCNT value is coded with 8 bits, the maximum startup time is about 62 ms.

When the counter reaches 0, the MOSCXTS bit is set, indicating that the main clock is valid. Setting the MOSCXTS bit in PMC_IMR can trigger an interrupt to the processor.

27.1.5.4 Main Clock Oscillator Selection

The user can select either the 4/8/12 MHz Fast RC oscillator or the 3 to 20 MHz Crystal or Ceramic Resonator-based oscillator to be the source of Main Clock.

The advantage of the 4/8/12 MHz Fast RC oscillator is that it provides fast startup time, this is why it is selected by default (to start up the system) and when entering Wait Mode.

The advantage of the 3 to 20 MHz Crystal or Ceramic Resonator-based oscillator is that it is very accurate.

The selection is made by writing the MOSCSEL bit in the Main Oscillator Register (CKGR_MOR). The switch of the Main Clock source is glitch free, so there is no need to run out of SLCK, PLLACK or PLLBCK in order to change the selection. The MOSCSELS bit of the Power Management Controller Status Register (PMC_SR) allows knowing when the switch sequence is done.

Setting the MOSCSELS bit in PMC_IMR can trigger an interrupt to the processor.

Enabling the Fast RC Oscillator (MOSCRGEN = 1) and changing the Fast RC Frequency (MOSCCRF) at the same time is not allowed.

The Fast RC must be enabled first and its frequency changed in a second step.

27.1.5.5 Main Clock Frequency Counter

The device features a Main Clock frequency counter that provides the frequency of the Main Clock.

The Main Clock frequency counter is reset and starts incrementing at the Main Clock speed after the next rising edge of the Slow Clock in the following cases:

- when the 4/8/12 MHz Fast RC oscillator clock is selected as the source of Main Clock and when this oscillator becomes stable (i.e., when the MOSCRCS bit is set)

- when the 3 to 20 MHz Crystal or Ceramic Resonator-based oscillator is selected as the source of Main Clock and when this oscillator becomes stable (i.e., when the MOSCXTS bit is set)
- when the Main Clock Oscillator selection is modified
- when the RCMEAS bit of CKGR_MFCR is written to 1.

Then, at the 16th falling edge of Slow Clock, the MAINFRDY bit in the Clock Generator Main Clock Frequency Register (CKGR_MCFR) is set and the counter stops counting. Its value can be read in the MAINF field of CKGR_MCFR and gives the number of Main Clock cycles during 16 periods of Slow Clock, so that the frequency of the 4/8/12 MHz Fast RC oscillator or 3 to 20 MHz Crystal or Ceramic Resonator-based oscillator can be determined.

27.1.6 Divider and PLL Block

The device features two Divider/PLL Blocks that permit a wide range of frequencies to be selected on either the master clock, the processor clock or the programmable clock outputs. Additionally, they provide a 48 MHz signal to the embedded USB device port regardless of the frequency of the main clock.

Figure 27-4 shows the block diagram of the dividers and PLL blocks.

Figure 27-4. Dividers and PLL Blocks Diagram

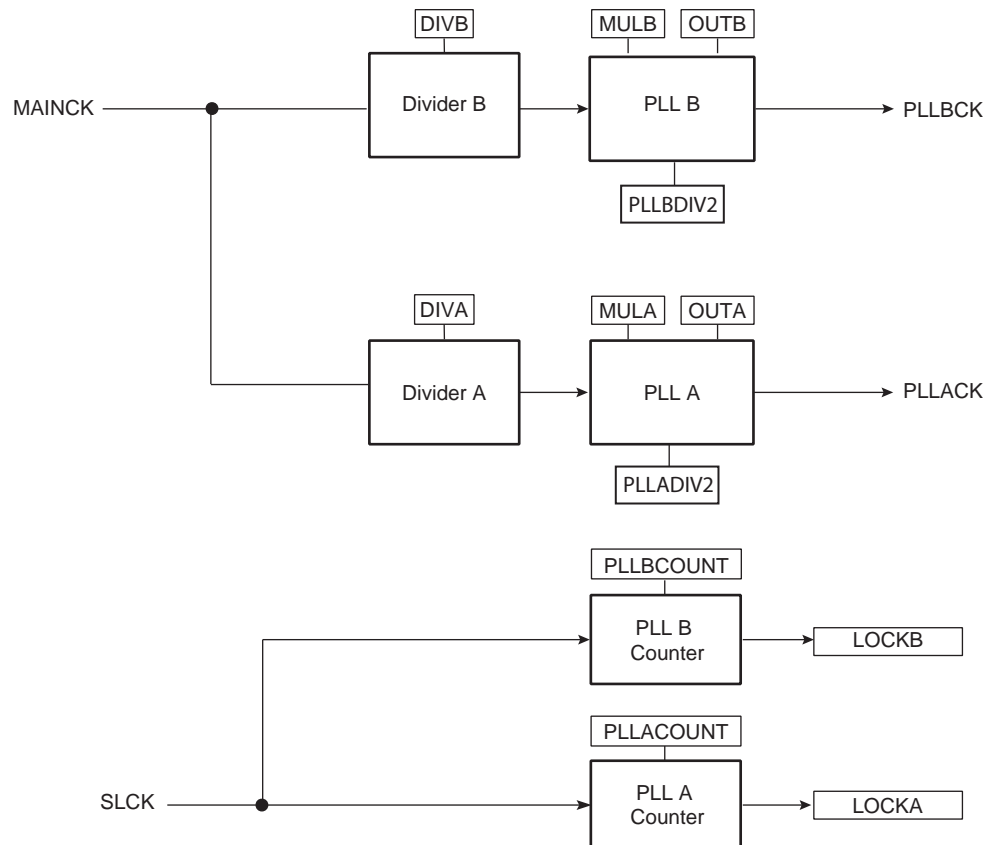

27.1.6.1 Divider and Phase Lock Loop Programming

The divider can be set between 1 and 255 in steps of 1. When a divider field (DIV) is set to 0, the output of the corresponding divider and the PLL output is a continuous signal at level 0. On reset, each DIV field is set to 0, thus the corresponding PLL input clock is set to 0.

The PLLs (PLLA, PLLB) allow multiplication of the divider's outputs. The PLL clock signal has a frequency that depends on the respective source signal frequency and on the parameters DIV (DIVA, DIVB) and MUL (MULA, MULB). The factor applied to the source signal frequency is $(MUL + 1)/DIV$. When MUL is written to 0, the PLL is disabled and its power consumption is saved. Re-enabling the PLL can be performed by writing a value higher than 0 in the MUL field.

Whenever the PLL is re-enabled or one of its parameters is changed, the LOCK (LOCKA, LOCKB) bit in PMC_SR is automatically cleared. The values written in the PLLCOUNT field (PLLACOUNT, PLLBCOUNT) in CKGR_PLLR (CKGR_PLLAR, CKGR_PLLBR) are loaded in the PLL counter. The PLL counter then decrements at the speed of the Slow Clock until it reaches 0. At this time, the LOCK bit is set in PMC_SR and can trigger an interrupt to the processor. The user has to load the number of Slow Clock cycles required to cover the PLL transient time into the PLLCOUNT field.

The PLL clock can be divided by 2 by writing the PLLDIV2 (PLLADIV2, PLLBDIV2) bit in PMC Master Clock Register (PMC_MCKR).

It is forbidden to change 4/8/12 MHz Fast RC oscillator, or main selection in CKGR_MOR register while Master clock source is PLL and PLL reference clock is the Fast RC oscillator.

The user must:

- Switch on the Main RC oscillator by writing 1 in CSS field of PMC_MCKR.
- Change the frequency (MOSCRCF) or oscillator selection (MOSCSEL) in CKGR_MOR.
- Wait for MOSCRCS (if frequency changes) or MOSCSELS (if oscillator selection changes) in PMC_IER.
- Disable and then enable the PLL (LOCK in PMC_IDR and PMC_IER).
- Wait for PLLRDY.
- Switch back to PLL.

27.2 Power Management Controller (PMC)

27.2.1 Description

The Power Management Controller (PMC) optimizes power consumption by controlling all system and user peripheral clocks. The PMC enables/disables the clock inputs to many of the peripherals and the Cortex-M4 Processor.

The Supply Controller selects between the 32 kHz RC oscillator or the crystal oscillator. The unused oscillator is disabled automatically so that power consumption is optimized.

By default, at startup the chip runs out of the Master Clock using the Fast RC oscillator running at 4 MHz.

The user can trim the 8 and 12 MHz RC Oscillator frequencies by software.

27.2.2 Embedded Characteristics

The Power Management Controller provides the following clocks:

- MCK, the Master Clock, programmable from a few hundred Hz to the maximum operating frequency of the device. It is available to the modules running permanently, such as the Enhanced Embedded Flash Controller.
- Processor Clock (HCLK), must be switched off when entering the processor in Sleep Mode.
- Free running processor Clock (FCLK)
- the Cortex-M4 SysTick external clock
- UDP Clock (UDPCK), required by USB Device Port operations.
- Peripheral Clocks, typically MCK, provided to the embedded peripherals (USART, SSC, SPI, TWI, TC, HSMCI, etc.) and independently controllable. In order to reduce the number of clock names in a product, the Peripheral Clocks are named MCK in the product datasheet.

Programmable Clock Outputs can be selected from the clocks provided by the clock generator and driven on the PCKx pins.

The Power Management Controller also provides the following operations on clocks:

- a main crystal oscillator clock failure detector.
- a frequency counter on main clock and an on-the-fly adjustable main RC oscillator frequency.

27.2.3 Block Diagram

Figure 27-5. General Clock Block Diagram

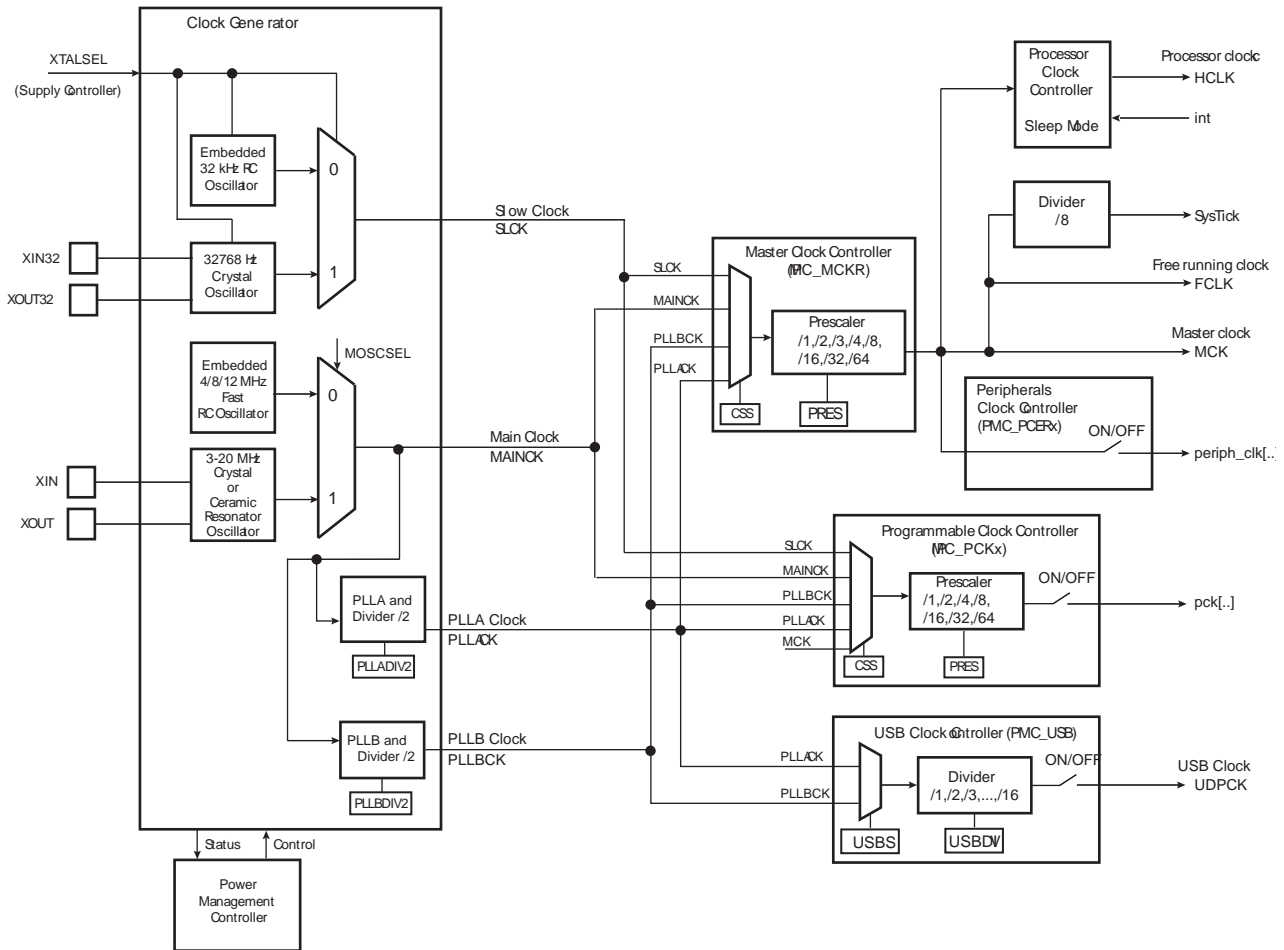

27.2.4 Master Clock Controller

The Master Clock Controller provides selection and division of the Master Clock (MCK). MCK is the clock provided to all the peripherals.

The Master Clock is selected from one of the clocks provided by the Clock Generator. Selecting the Slow Clock provides a Slow Clock signal to the whole device. Selecting the Main Clock saves power consumption of the PLLs.

The Master Clock Controller is made up of a clock selector and a prescaler.

The Master Clock selection is made by writing the CSS field (Clock Source Selection) in PMC_MCKR (Master Clock Register). The prescaler supports the division by a power of 2 of the selected clock between 1 and 64, and the division by 3. The PRES field in PMC_MCKR programs the prescaler.

Each time PMC_MCKR is written to define a new Master Clock, the MCKRDY bit is cleared in PMC_SR. It reads 0 until the Master Clock is established. Then, the MCKRDY bit is set and can trigger an interrupt to the processor. This feature is useful when switching from a high-speed clock to a lower one to inform the software when the change is actually done.

Figure 27-6. Master Clock Controller

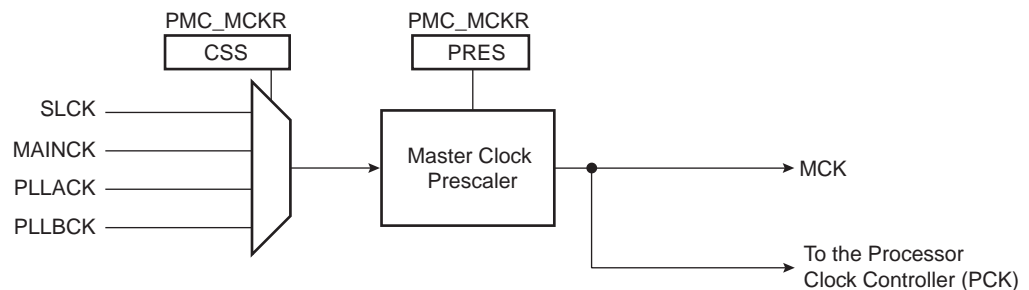

27.2.5 Processor Clock Controller

The PMC features a Processor Clock Controller (HCLK) that implements the Processor Sleep Mode. The Processor Clock can be disabled by executing the WFI (WaitForInterrupt) processor instruction.

The Processor Clock HCLK is enabled after a reset and is automatically re-enabled by any enabled interrupt. The Processor Sleep Mode is achieved by disabling the Processor Clock, which is automatically re-enabled by any enabled fast or normal interrupt, or by the reset of the product.

When Processor Sleep Mode is entered, the current instruction is finished before the clock is stopped, but this does not prevent data transfers from other masters of the system bus.

27.2.6 SysTick Clock

The SysTick calibration value is fixed to 12500 which allows the generation of a time base of 1 ms with SysTick clock to the maximum frequency on MCK divided by 8.

27.2.7 USB Clock Controller

The user can select the PLLA or the PLLB output as the USB Source Clock by writing the USBS bit in PMC_USB. If using the USB, the user must program the PLL to generate an appropriate frequency depending on the USBDIV bit in PMC_USB.

When the PLL output is stable, i.e., the LOCK bit is set:

- The USB device clock can be enabled by setting the UDP bit in PMC_SCER. To save power on this peripheral when it is not used, the user can set the UDP bit in PMC_SCDR. The UDP bit in PMC_SCSR gives the activity of this clock. The USB device port requires both the 48 MHz signal and the Master Clock. The Master Clock may be controlled by means of the Master Clock Controller.

Figure 27-7. USB Clock Controller

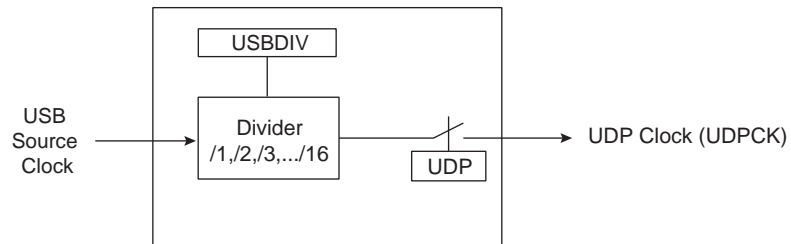

27.2.8 Peripheral Clock Controller

The Power Management Controller controls the clocks of each embedded peripheral by means of the Peripheral Clock Controller. The user can individually enable and disable the Clock on the peripherals.

The user can also enable and disable these clocks by writing Peripheral Clock Enable 0 (PMC_PCER0), Peripheral Clock Disable 0 (PMC_PCDR0), Peripheral Clock Enable 1 (PMC_PCER1) and Peripheral Clock Disable 1 (PMC_PCDR1) registers. The status of the peripheral clock activity can be read in the Peripheral Clock Status Register (PMC_PCSR0) and Peripheral Clock Status Register (PMC_PCSR1).

When a peripheral clock is disabled, the clock is immediately stopped. The peripheral clocks are automatically disabled after a reset.

In order to stop a peripheral, it is recommended that the system software wait until the peripheral has executed its last programmed operation before disabling the clock. This is to avoid data corruption or erroneous behavior of the system.

The bit number within the Peripheral Clock Control registers (PMC_PCER0-1, PMC_PCDR0-1, and PMC_PCSR0-1) is the Peripheral Identifier defined at the product level. The bit number corresponds to the interrupt source number assigned to the peripheral.

27.2.9 Free Running Processor Clock

The Free Running Processor Clock (FCLK) used for sampling interrupts and clocking debug blocks ensures that interrupts can be sampled, and sleep events can be traced, while the processor is sleeping. It is connected to Master Clock (MCK).

27.2.10 Programmable Clock Output Controller

The PMC controls 3 signals to be output on external pins, PCKx. Each signal can be independently programmed via the Programmable Clock Registers (PMC_PCKx).

PCKx can be independently selected between the Slow Clock (SLCK), the Main Clock (MAINCK), the PLLA Clock (PLLACK), the PLLB Clock (PLLBACK) and the Master Clock (MCK) by writing the CSS field in PMC_PCKx. Each output signal can also be divided by a power of 2 between 1 and 64 by writing the PRES (Prescaler) field in PMC_PCKx.

Each output signal can be enabled and disabled by writing 1 in the corresponding bit, PCKx of PMC_SCER and PMC_SCDR, respectively. Status of the active programmable output clocks are given in the PCKx bits of PMC_SCSR (System Clock Status Register).

Moreover, like the PCK, a status bit in PMC_SR indicates that the Programmable Clock is actually what has been programmed in the Programmable Clock registers.

As the Programmable Clock Controller does not manage with glitch prevention when switching clocks, it is strongly recommended to disable the Programmable Clock before any configuration change and to re-enable it after the change is actually performed.

27.2.11 Fast Startup

The device allows the processor to restart in less than 10 microseconds while the device is in Wait Mode.

The system enters Wait Mode by writing the WAITMODE bit at 1 in the PMC Clock Generator Main Oscillator Register (CKGR_MOR). Waiting for MOSCRGEN bit to be cleared is strongly recommended to ensure that the core will not execute undesired instructions.

Important: Prior to instructing the system to enter in Wait Mode, the internal sources of wakeup provided by RTT, RTC and USB must be cleared and verified too, that none of the enabled external wakeup inputs (WKUP) hold an active polarity.

A Fast Startup is enabled upon the detection of a programmed level on one of the 16 wake-up inputs (WKUP) or upon an active alarm from the RTC, RTT and USB Controller. The polarity of the 16 wake-up inputs is programmable by writing the PMC Fast Startup Polarity Register (PMC_FSPR).

The Fast Restart circuitry, as shown in [Figure 27-8](#), is fully asynchronous and provides a fast startup signal to the Power Management Controller. As soon as the fast startup signal is asserted, the embedded 4/8/12 MHz Fast RC oscillator restarts automatically.

When entering the Wait Mode, the embedded flash can be placed in low power mode depending on the configuration of the FLPM in PMC_FSMR register. This bitfield can be programmed anytime and will be taken into account at the next time the system enters Wait Mode.

The power consumption reduction is optimal when configuring 1 (deep power down mode) in FLPM. If 0 is programmed (standby mode), the power consumption is slightly higher as compared to the deep power down mode.

When programming 2 in FLPM, the Wait Mode flash power consumption is equivalent to the active mode when there is no read access on the flash.

Figure 27-8. Fast Startup Circuitry

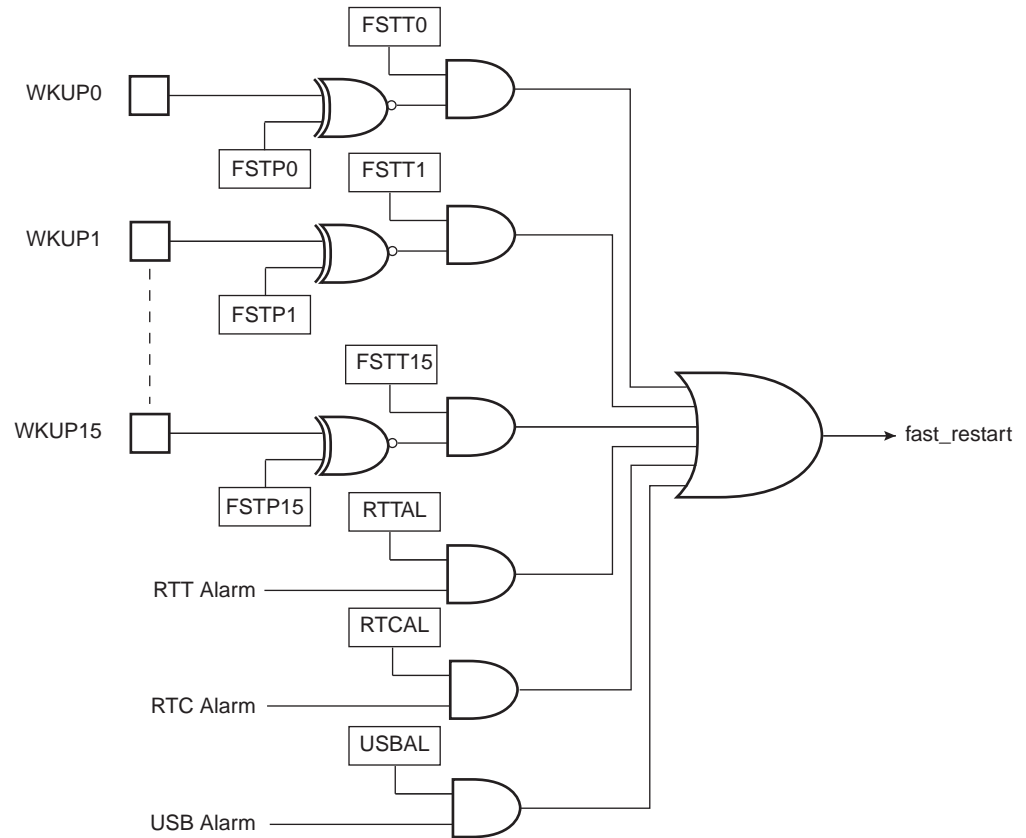

Each wake-up input pin and alarm can be enabled to generate a Fast Startup event by writing 1 to the corresponding bit in the Fast Startup Mode Register PMC_FSMR.

The user interface does not provide any status for Fast Startup, but the user can easily recover this information by reading the PIO Controller and the status registers of the RTC, RTT and USB Controller.

27.2.12 Main Crystal Clock Failure Detector

The clock failure detector monitors the 3 to 20 MHz Crystal or Ceramic Resonator-based oscillator to identify an eventual defect of this oscillator (for example, if the crystal is unconnected).

The clock failure detector can be enabled or disabled by means of the CFDEN bit in the PMC Clock Generator Main Oscillator Register (CKGR_MOR). After reset, the detector is disabled. However, if the 3 to 20 MHz Crystal or Ceramic Resonator-based Oscillator is disabled, the clock failure detector is disabled too.

The slow RC oscillator must be enabled. The clock failure detection must be enabled only when system clock MCK selects the fast RC oscillator. Then the status register must be read 2 slow clock cycles after enabling.

A failure is detected by means of a counter incrementing on the 3 to 20 MHz Crystal oscillator or Ceramic Resonator-based oscillator clock edge and timing logic clocked on the slow clock RC oscillator controlling the counter. The counter is cleared when the slow clock RC oscillator signal is low and enabled when the slow clock RC oscillator is high. Thus the failure detection time is 1

slow clock RC oscillator clock period. If, during the high level period of the slow clock RC oscillator, less than 8 fast crystal oscillator clock periods have been counted, then a failure is declared.

If a failure of the 3 to 20 MHz Crystal or Ceramic Resonator-based oscillator clock is detected, the CFDEV flag is set in the PMC Status Register (PMC_SR), and generates an interrupt if it is not masked. The interrupt remains active until a read operation in the PMC_SR register. The user can know the status of the clock failure detector at any time by reading the CFDS bit in the PMC_SR register.

If the 3 to 20 MHz Crystal or Ceramic Resonator-based oscillator clock is selected as the source clock of MAINCK (MOSCSEL = 1), and if the Master Clock Source is PLLACK or PLLBCK (CSS = 2 or 3), a clock failure detection automatically forces MAINCK to be the source clock for the master clock (MCK). Then, regardless of the PMC configuration, a clock failure detection automatically forces the 4/8/12 MHz Fast RC oscillator to be the source clock for MAINCK. If the Fast RC oscillator is disabled when a clock failure detection occurs, it is automatically re-enabled by the clock failure detection mechanism.

It takes 2 slow clock RC oscillator cycles to detect and switch from the 3 to 20 MHz Crystal, or Ceramic Resonator-based oscillator, to the 4/8/12 MHz Fast RC Oscillator if the Master Clock source is Main Clock, or 3 slow clock RC oscillator cycles if the Master Clock source is PLLACK or PLLBCK.

A clock failure detection activates a fault output that is connected to the Pulse Width Modulator (PWM) Controller. With this connection, the PWM controller is able to force its outputs and to protect the driven device, if a clock failure is detected. This fault output remains active until the defect is detected and until it is cleared by the bit FOCLR in the PMC Fault Output Clear Register (PMC_FOCR).

The user can know the status of the fault output at any time by reading the FOS bit in the PMC_SR register.

27.2.13 Programming Sequence

1. Enabling the Main Oscillator:

The main oscillator is enabled by setting the MOSCXTEN field in the Main Oscillator Register (CKGR_MOR). The user can define a start-up time. This can be achieved by writing a value in the MOSCXTST field in CKGR_MOR. Once this register has been correctly configured, the user must wait for MOSCXTS field in the PMC_SR register to be set. This can be done either by polling the status register, or by waiting the interrupt line to be raised if the associated interrupt to MOSCXTS has been enabled in the PMC_IER register.

Start Up Time = $8 * \text{MOSCXTST} / \text{SLCK} = 56$ Slow Clock Cycles.

The main oscillator will be enabled (MOSCXTS bit set) after 56 Slow Clock Cycles.

2. Checking the Main Oscillator Frequency (Optional):

In some situations the user may need an accurate measure of the main clock frequency. This measure can be accomplished via the Main Clock Frequency Register (CKGR_MCFR).

Once the MAINFRDY field is set in CKGR_MCFR, the user may read the MAINF field in CKGR_MCFR. This provides the number of main clock cycles within sixteen slow clock cycles.

3. Setting PLL and Divider:

All parameters needed to configure PLLA and the divider are located in CKGR_PLLAxR.

The DIV field is used to control the divider itself. It must be set to 1 when PLL is used. By default, DIV parameter is set to 0 which means that the divider is turned off.

The MUL field is the PLL multiplier factor. This parameter can be programmed between 0 and 62. If MUL is set to 0, PLL will be turned off, otherwise the PLL output frequency is PLL input frequency multiplied by (MUL + 1).

The PLLCOUNT field specifies the number of slow clock cycles before the LOCK bit is set in PMC_SR, after CKGR_PLLAxR has been written.

Once the CKGR_PLL register has been written, the user must wait for the LOCK bit to be set in the PMC_SR. This can be done either by polling the status register or by waiting the interrupt line to be raised if the associated interrupt to LOCK has been enabled in PMC_IER. All parameters in CKGR_PLLAxR can be programmed in a single write operation. If at some stage one of the following parameters, MUL or DIV is modified, the LOCK bit will go low to indicate that PLL is not ready yet. When PLL is locked, LOCK will be set again. The user is constrained to wait for LOCK bit to be set before using the PLL output clock.

4. Selection of Master Clock and Processor Clock

The Master Clock and the Processor Clock are configurable via the Master Clock Register (PMC_MCKR).

The CSS field is used to select the Master Clock divider source. By default, the selected clock source is main clock.

The PRES field is used to control the Master Clock prescaler. The user can choose between different values (1, 2, 3, 4, 8, 16, 32, 64). Master Clock output is prescaler input divided by PRES parameter. By default, PRES parameter is set to 1 which means that master clock is equal to main clock.

Once PMC_MCKR has been written, the user must wait for the MCKRDY bit to be set in PMC_SR. This can be done either by polling the status register or by waiting for the interrupt line to be raised if the associated interrupt to MCKRDY has been enabled in the PMC_IER register.

The PMC_MCKR must not be programmed in a single write operation. The preferred programming sequence for PMC_MCKR is as follows:

- If a new value for CSS field corresponds to PLL Clock,
 - Program the PRES field in PMC_MCKR.
 - Wait for the MCKRDY bit to be set in PMC_SR.
 - Program the CSS field in PMC_MCKR.
 - Wait for the MCKRDY bit to be set in PMC_SR.
- If a new value for CSS field corresponds to Main Clock or Slow Clock,
 - Program the CSS field in PMC_MCKR.
 - Wait for the MCKRDY bit to be set in the PMC_SR.
 - Program the PRES field in PMC_MCKR.
 - Wait for the MCKRDY bit to be set in PMC_SR.

If at some stage one of the following parameters, CSS or PRES is modified, the MCKRDY bit will go low to indicate that the Master Clock and the Processor Clock are not ready yet. The user must wait for MCKRDY bit to be set again before using the Master and Processor Clocks.

Note: IF PLLx clock was selected as the Master Clock and the user decides to modify it by writing in CKGR_PLLR, the MCKRDY flag will go low while PLL is unlocked. Once PLL is locked again, LOCK goes high and MCKRDY is set. While PLL is unlocked, the Master Clock selection is automatically changed to Slow Clock. For further information, see [Section 27.2.14.2 "Clock Switching Waveforms" on page 493](#).

Code Example:

```
write_register(PMC_MCKR, 0x00000001)
wait (MCKRDY=1)
write_register(PMC_MCKR, 0x00000011)
wait (MCKRDY=1)
```

The Master Clock is main clock divided by 2.

The Processor Clock is the Master Clock.

5. Selection of Programmable Clocks

Programmable clocks are controlled via registers, PMC_SCER, PMC_SCDR and PMC_SCSR.

Programmable clocks can be enabled and/or disabled via PMC_SCER and PMC_SCDR. 3 Programmable clocks can be enabled or disabled. The PMC_SCSR provides a clear indication as to which Programmable clock is enabled. By default all Programmable clocks are disabled.

Programmable Clock Registers (PMC_PCKx) are used to configure Programmable clocks.

The CSS field is used to select the Programmable clock divider source. Four clock options are available: main clock, slow clock, PLLACK, PLLBCK. By default, the clock source selected is slow clock.

The PRES field is used to control the Programmable clock prescaler. It is possible to choose between different values (1, 2, 4, 8, 16, 32, 64). Programmable clock output is prescaler input divided by PRES parameter. By default, the PRES parameter is set to 0 which means that master clock is equal to slow clock.

Once PMC_PCKx has been programmed, The corresponding Programmable clock must be enabled and the user is constrained to wait for the PCKRDYx bit to be set in PMC_SR. This can be done either by polling the status register or by waiting the interrupt line to be raised, if the associated interrupt to PCKRDYx has been enabled in the PMC_IER register. All parameters in PMC_PCKx can be programmed in a single write operation.

If the CSS and PRES parameters are to be modified, the corresponding Programmable clock must be disabled first. The parameters can then be modified. Once this has been done, the user must re-enable the Programmable clock and wait for the PCKRDYx bit to be set.

6. Enabling Peripheral Clocks

Once all of the previous steps have been completed, the peripheral clocks can be enabled and/or disabled via registers PMC_PCER0, PMC_PCER, PMC_PCDR0 and PMC_PCDR.

27.2.14 Clock Switching Details

27.2.14.1 Master Clock Switching Timings

Table 27-1 and Table 27-2 give the worst case timings required for the Master Clock to switch from one selected clock to another one. This is in the event that the prescaler is de-activated. When the prescaler is activated, an additional time of 64 clock cycles of the newly selected clock has to be added.

Table 27-1. Clock Switching Timings (Worst Case)

To	From	Main Clock	SLCK	PLL Clock
Main Clock		–	4 x SLCK + 2.5 x Main Clock	3 x PLL Clock + 4 x SLCK + 1 x Main Clock
SLCK		0.5 x Main Clock + 4.5 x SLCK	–	3 x PLL Clock + 5 x SLCK
PLL Clock		0.5 x Main Clock + 4 x SLCK + PLLCOUNT x SLCK + 2.5 x PLLx Clock	2.5 x PLL Clock + 5 x SLCK + PLLCOUNT x SLCK	2.5 x PLL Clock + 4 x SLCK + PLLCOUNT x SLCK

- Notes: 1. PLL designates either the PLLA or the PLLB Clock.
2. PLLCOUNT designates either PLLACOUNT or PLLBCOUNT.

Table 27-2. Clock Switching Timings between Two PLLs (Worst Case)

To	From	PLLA Clock	PLLB Clock
PLLA Clock		2.5 x PLLA Clock + 4 x SLCK + PLLACOUNT x SLCK	3 x PLLA Clock + 4 x SLCK + 1.5 x PLLA Clock
PLLB Clock		3 x PLLB Clock + 4 x SLCK + 1.5 x PLLB Clock	2.5 x PLLB Clock + 4 x SLCK + PLLBCOUNT x SLCK

27.2.14.2 Clock Switching Waveforms

Figure 27-9. Switch Master Clock from Slow Clock to PLLx Clock

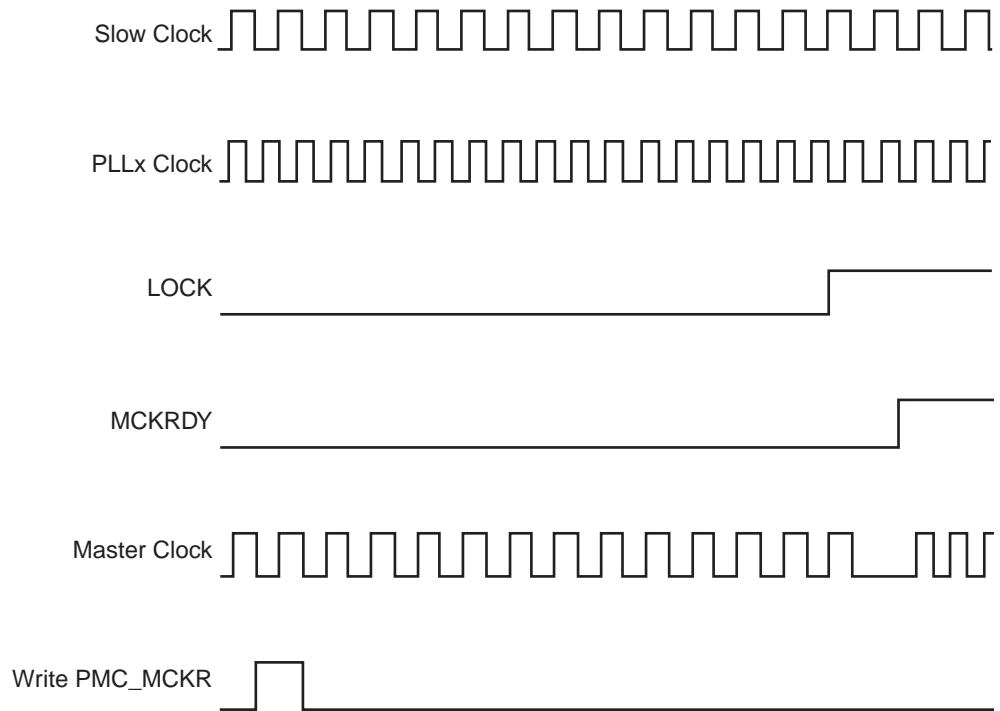

Figure 27-10. Switch Master Clock from Main Clock to Slow Clock

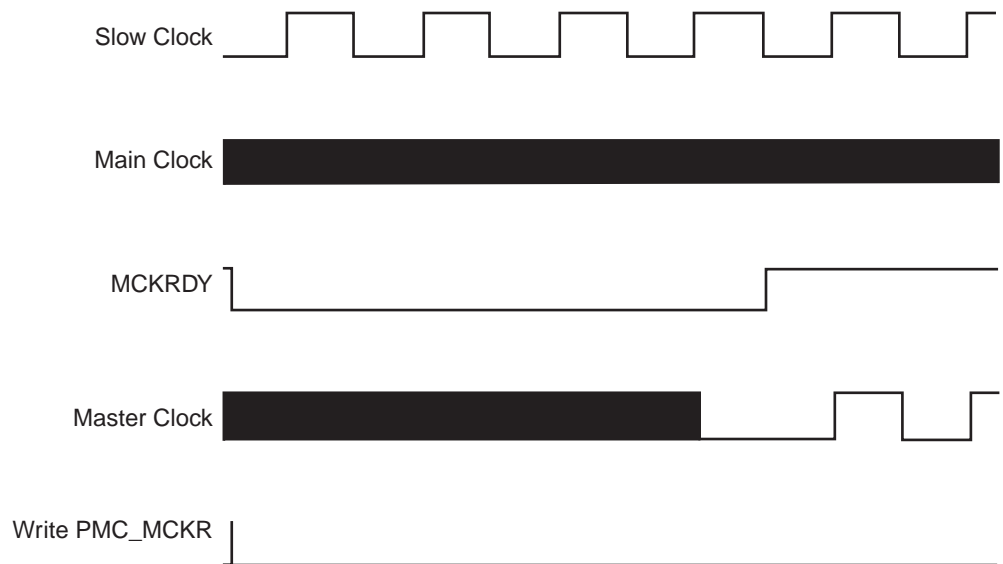

Figure 27-11. Change PLLx Programming

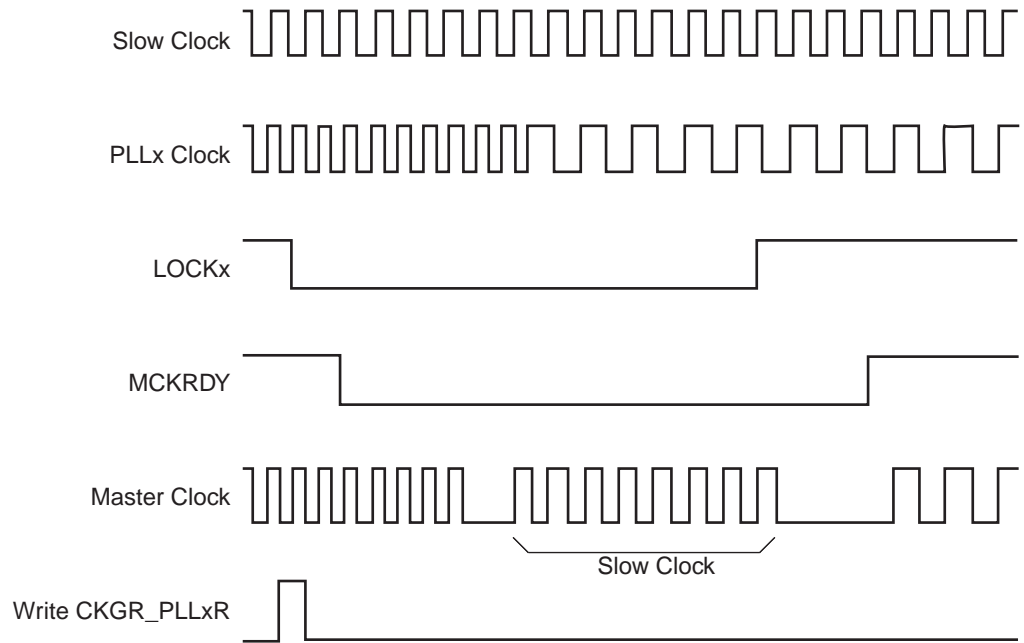
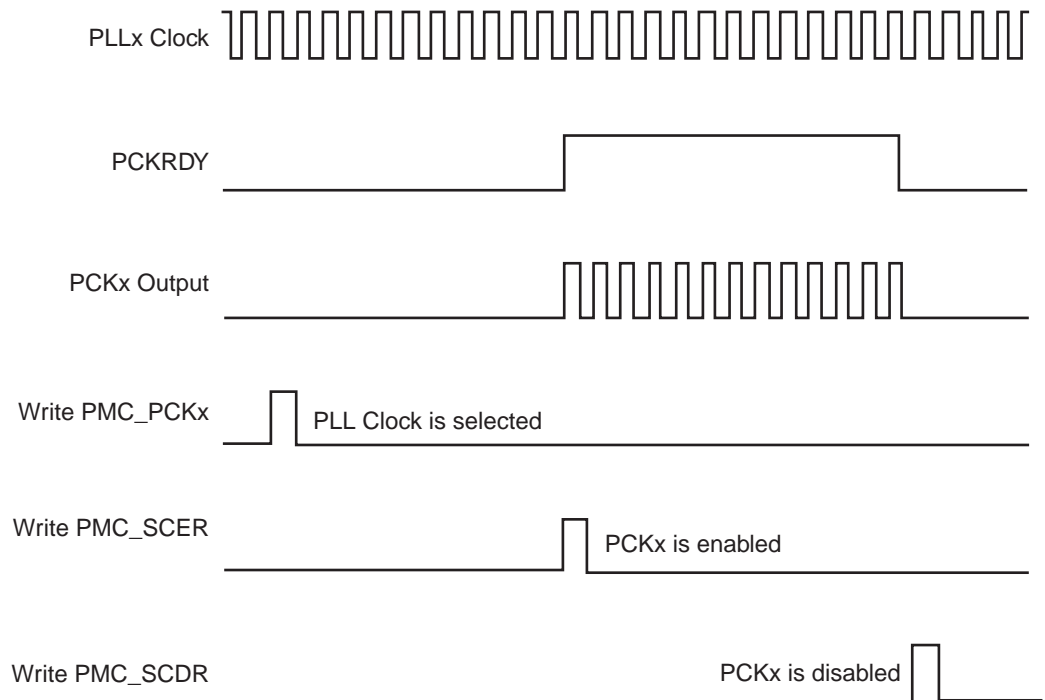

Figure 27-12. Programmable Clock Output Programming



27.2.15 Write Protection Registers

To prevent any single software error that may corrupt PMC behavior, certain address spaces can be write protected by setting the WPEN bit in the “[PMC Write Protect Mode Register](#)” (PMC_WPMR).

If a write access to the protected registers is detected, then the WPVS flag in the PMC Write Protect Status Register (PMC_WPSR) is set and the field WPVSRC indicates in which register the write access has been attempted.

The WPVS flag is reset by writing the PMC Write Protect Mode Register (PMC_WPMR) with the appropriate access key, WPKEY.

The protected registers are:

“[PMC System Clock Enable Register](#)”

“[PMC System Clock Disable Register](#)”

“[PMC Peripheral Clock Enable Register 0](#)”

“[PMC Peripheral Clock Disable Register 0](#)”

“[PMC Clock Generator Main Oscillator Register](#)”

“[PMC Clock Generator PLLA Register](#)”

“[PMC Clock Generator PLLB Register](#)”

“[PMC Master Clock Register](#)”

“[PMC USB Clock Register](#)”

“[PMC Programmable Clock Register](#)”

“[PMC Fast Startup Mode Register](#)”

“[PMC Fast Startup Polarity Register](#)”

“[PMC Peripheral Clock Enable Register 1](#)”

“[PMC Peripheral Clock Disable Register 1](#)”

“[PMC Oscillator Calibration Register](#)”

27.2.16 Power Management Controller (PMC) User Interface

Table 27-3. Register Mapping

Offset	Register	Name	Access	Reset
0x0000	System Clock Enable Register	PMC_SCER	Write-only	–
0x0004	System Clock Disable Register	PMC_SCDR	Write-only	–
0x0008	System Clock Status Register	PMC_SCSR	Read-only	0x0000_0001
0x000C	Reserved	–	–	–
0x0010	Peripheral Clock Enable Register 0	PMC_PCER0	Write-only	–
0x0014	Peripheral Clock Disable Register 0	PMC_PCDR0	Write-only	–
0x0018	Peripheral Clock Status Register 0	PMC_PCSR0	Read-only	0x0000_0000
0x001C	Reserved	–	–	–
0x0020	Main Oscillator Register	CKGR_MOR	Read-write	0x0000_0001
0x0024	Main Clock Frequency Register	CKGR_MCFR	Read-write	0x0000_0000
0x0028	PLLA Register	CKGR_PLLAR	Read-write	0x0000_3F00
0x002C	PLLB Register	CKGR_PLLBR	Read-write	0x0000_3F00
0x0030	Master Clock Register	PMC_MCKR	Read-write	0x0000_0001
0x0034	Reserved	–	–	–
0x0038	USB Clock Register	PMC_USB	Read/Write	0x0000_0000
0x003C	Reserved	–	–	–
0x0040	Programmable Clock 0 Register	PMC_PCK0	Read-write	0x0000_0000
0x0044	Programmable Clock 1 Register	PMC_PCK1	Read-write	0x0000_0000
0x0048	Programmable Clock 2 Register	PMC_PCK2	Read-write	0x0000_0000
0x004C - 0x005C	Reserved	–	–	–
0x0060	Interrupt Enable Register	PMC_IER	Write-only	–
0x0064	Interrupt Disable Register	PMC_IDR	Write-only	–
0x0068	Status Register	PMC_SR	Read-only	0x0001_0008
0x006C	Interrupt Mask Register	PMC_IMR	Read-only	0x0000_0000
0x0070	Fast Startup Mode Register	PMC_FSMR	Read-write	0x0000_0000
0x0074	Fast Startup Polarity Register	PMC_FSPR	Read-write	0x0000_0000
0x0078	Fault Output Clear Register	PMC_FOCR	Write-only	–
0x007C- 0x00E0	Reserved	–	–	–
0x00E4	Write Protect Mode Register	PMC_WPMR	Read-write	0x0
0x00E8	Write Protect Status Register	PMC_WPSR	Read-only	0x0
0x00EC-0x00FC	Reserved	–	–	–
0x0100	Peripheral Clock Enable Register 1	PMC_PCER1	Write-only	–
0x0104	Peripheral Clock Disable Register 1	PMC_PCDR1	Write-only	–

Table 27-3. Register Mapping

Offset	Register	Name	Access	Reset
0x0108	Peripheral Clock Status Register 1	PMC_PCSR1	Read-only	0x0000_0000
0x010C	Reserved	–	–	–
0x0110	Oscillator Calibration Register	PMC_OCR	Read-write	0x0040_4040

Note: If an offset is not listed in the table it must be considered as “reserved”.

27.2.16.1 PMC System Clock Enable Register

Name: PMC_SCER

Address: 0x400E0400

Access: Write-only

31	30	29	28	27	26	25	24
–	–	–	–	–	–	–	–
23	22	21	20	19	18	17	16
–	–	–	–	–	–	–	–
15	14	13	12	11	10	9	8
–	–	–	–	–	PCK2	PCK1	PCK0
7	6	5	4	3	2	1	0
UDP	–	–	–	–	–	–	–

This register can only be written if the WPEN bit is cleared in [“PMC Write Protect Mode Register”](#) .

- **UDP: USB Device Port Clock Enable**

0 = No effect.

1 = Enables the 48 MHz clock (UDPCK) of the USB Device Port.

- **PCKx: Programmable Clock x Output Enable**

0 = No effect.

1 = Enables the corresponding Programmable Clock output.

27.2.16.2 PMC System Clock Disable Register

Name: PMC_SCDR

Address: 0x400E0404

Access: Write-only

31	30	29	28	27	26	25	24
–	–	–	–	–	–	–	–
23	22	21	20	19	18	17	16
–	–	–	–	–	–	–	–
15	14	13	12	11	10	9	8
–	–	–	–	–	PCK2	PCK1	PCK0
7	6	5	4	3	2	1	0
UDP	–	–	–	–	–	–	–

This register can only be written if the WPEN bit is cleared in [“PMC Write Protect Mode Register”](#) .

- **UDP: USB Device Port Clock Disable**

0 = No effect.

1 = Disables the 48 MHz clock (UDPCK) of the USB Device Port.

- **PCKx: Programmable Clock x Output Disable**

0 = No effect.

1 = Disables the corresponding Programmable Clock output.

27.2.16.3 *PMC System Clock Status Register*

Name: PMC_SCSR

Address: 0x400E0408

Access: Read-only

31	30	29	28	27	26	25	24
–	–	–	–	–	–	–	–
23	22	21	20	19	18	17	16
–	–	–	–	–	–	–	–
15	14	13	12	11	10	9	8
–	–	–	–	–	PCK2	PCK1	PCK0
7	6	5	4	3	2	1	0
UDP	–	–	–	–	–	–	–

- **UDP: USB Device Port Clock Status**

0 = The 48 MHz clock (UDPCK) of the USB Device Port is disabled.

1 = The 48 MHz clock (UDPCK) of the USB Device Port is enabled.

- **PCKx: Programmable Clock x Output Status**

0 = The corresponding Programmable Clock output is disabled.

1 = The corresponding Programmable Clock output is enabled.

27.2.16.4 PMC Peripheral Clock Enable Register 0

Name: PMC_PCER0

Address: 0x400E0410

Access: Write-only

31	30	29	28	27	26	25	24
PID31	PID30	PID29	PID28	PID27	PID26	PID25	PID24
23	22	21	20	19	18	17	16
PID23	PID22	PID21	PID20	PID19	PID18	PID17	PID16
15	14	13	12	11	10	9	8
PID15	PID14	PID13	PID12	PID11	PID10	PID9	PID8
7	6	5	4	3	2	1	0
PID7	PID6	PID5	PID4	PID3	PID2	–	–

This register can only be written if the WPEN bit is cleared in [“PMC Write Protect Mode Register”](#) .

- **PIDx: Peripheral Clock x Enable**

0 = No effect.

1 = Enables the corresponding peripheral clock.

Note: To get PIDx, refer to identifiers as defined in the section “Peripheral Identifiers” in the product datasheet. Other peripherals can be enabled in PMC_PCER1 ([Section 27.2.16.23 “PMC Peripheral Clock Enable Register 1”](#)).

Note: Programming the control bits of the Peripheral ID that are not implemented has no effect on the behavior of the PMC.



27.2.16.5 PMC Peripheral Clock Disable Register 0

Name: PMC_PCDR0

Address: 0x400E0414

Access: Write-only

31	30	29	28	27	26	25	24
PID31	PID30	PID29	PID28	PID27	PID26	PID25	PID24
23	22	21	20	19	18	17	16
PID23	PID22	PID21	PID20	PID19	PID18	PID17	PID16
15	14	13	12	11	10	9	8
PID15	PID14	PID13	PID12	PID11	PID10	PID9	PID8
7	6	5	4	3	2	1	0
PID7	PID6	PID5	PID4	PID3	PID2	-	-

This register can only be written if the WPEN bit is cleared in ["PMC Write Protect Mode Register"](#) .

- **PIDx: Peripheral Clock x Disable**

0 = No effect.

1 = Disables the corresponding peripheral clock.

Note: To get PIDx, refer to identifiers as defined in the section "Peripheral Identifiers" in the product datasheet. Other peripherals can be disabled in PMC_PCDR1 ([Section 27.2.16.24 "PMC Peripheral Clock Disable Register 1"](#)).

27.2.16.6 PMC Peripheral Clock Status Register 0

Name: PMC_PCSR0

Address: 0x400E0418

Access: Read-only

31	30	29	28	27	26	25	24
PID31	PID30	PID29	PID28	PID27	PID26	PID25	PID24
23	22	21	20	19	18	17	16
PID23	PID22	PID21	PID20	PID19	PID18	PID17	PID16
15	14	13	12	11	10	9	8
PID15	PID14	PID13	PID12	PID11	PID10	PID9	PID8
7	6	5	4	3	2	1	0
PID7	PID6	PID5	PID4	PID3	PID2	–	–

- **PIDx: Peripheral Clock x Status**

0 = The corresponding peripheral clock is disabled.

1 = The corresponding peripheral clock is enabled.

Note: To get PIDx, refer to identifiers as defined in the section “Peripheral Identifiers” in the product datasheet. Other peripherals status can be read in PMC_PCSR1 ([Section 27.2.16.25 “PMC Peripheral Clock Status Register 1”](#)).

27.2.16.7 PMC Clock Generator Main Oscillator Register

Name: CKGR_MOR

Address: 0x400E0420

Access: Read-write

31	30	29	28	27	26	25	24
–	–	–	–	–	–	CFDEN	MOSCSEL
23	22	21	20	19	18	17	16
KEY							
15	14	13	12	11	10	9	8
MOSCXTST							
7	6	5	4	3	2	1	0
–	MOSCRCF			MOSRCEN	WAITMODE	MOSCXTBY	MOSCXTEN

This register can only be written if the WPEN bit is cleared in “[PMC Write Protect Mode Register](#)” .

- **KEY: Password**

Should be written at value 0x37. Writing any other value in this field aborts the write operation.

- **MOSCXTEN: Main Crystal Oscillator Enable**

A crystal must be connected between XIN and XOUT.

0 = The Main Crystal Oscillator is disabled.

1 = The Main Crystal Oscillator is enabled. MOSCXTBY must be set to 0.

When MOSCXTEN is set, the MOSCXTS flag is set once the Main Crystal Oscillator startup time is achieved.

- **MOSCXTBY: Main Crystal Oscillator Bypass**

0 = No effect.

1 = The Main Crystal Oscillator is bypassed. MOSCXTEN must be set to 0. An external clock must be connected on XIN.

When MOSCXTBY is set, the MOSCXTS flag in PMC_SR is automatically set.

Clearing MOSCXTEN and MOSCXTBY bits allows resetting the MOSCXTS flag.

- **WAITMODE: Wait Mode Command**

0 = No effect.

1 = Enters the device in Wait Mode.

Note: The WAITMODE bit is write-only.

- **MOSRCEN: Main On-Chip RC Oscillator Enable**

0 = The Main On-Chip RC Oscillator is disabled.

1 = The Main On-Chip RC Oscillator is enabled.

When MOSRCEN is set, the MOSCRCS flag is set once the Main On-Chip RC Oscillator startup time is achieved.

- **MOSCRCF: Main On-Chip RC Oscillator Frequency Selection**

At start-up, the Main On-Chip RC Oscillator frequency is 4 MHz.

Value	Name	Description
0x0	4_MHz	The Fast RC Oscillator Frequency is at 4 MHz (default)
0x1	8_MHz	The Fast RC Oscillator Frequency is at 8 MHz
0x2	12_MHz	The Fast RC Oscillator Frequency is at 12 MHz

Note: MOSCRCF must be changed only if MOSCRCS is set in PMC_SR register. Therefore MOSCRCF and MOSRCEN cannot be changed at the same time.

- **MOSCXTST: Main Crystal Oscillator Start-up Time**

Specifies the number of Slow Clock cycles multiplied by 8 for the Main Crystal Oscillator start-up time.

- **MOSCSEL: Main Oscillator Selection**

0 = The Main On-Chip RC Oscillator is selected.

1 = The Main Crystal Oscillator is selected.

- **CFDEN: Clock Failure Detector Enable**

0 = The Clock Failure Detector is disabled.

1 = The Clock Failure Detector is enabled.

- Notes:
1. The slow RC oscillator must be enabled when the CFDEN is enabled.
 2. The clock failure detection must be enabled only when system clock MCK selects the fast RC oscillator.
 3. Then the status register must be read 2 slow clock cycles after enabling.



27.2.16.8 PMC Clock Generator Main Clock Frequency Register

Name: CKGR_MCFR

Address: 0x400E0424

Access: Read-Write

31	30	29	28	27	26	25	24
–	–	–	–	–	–	–	–
23	22	21	20	19	18	17	16
–	–	–	RCMEAS	–	–	–	MAINFRDY
15	14	13	12	11	10	9	8
MAINF							
7	6	5	4	3	2	1	0
MAINF							

This register can only be written if the WPEN bit is cleared in [“PMC Write Protect Mode Register”](#) .

- **MAINF: Main Clock Frequency**

Gives the number of Main Clock cycles within 16 Slow Clock periods.

- **MAINFRDY: Main Clock Ready**

0 = MAINF value is not valid or the Main Oscillator is disabled or a measure has just been started by means of RCMEAS.

1 = The Main Oscillator has been enabled previously and MAINF value is available.

- **RCMEAS: RC Oscillator Frequency Measure (write-only)**

0 = No effect.

1 = Restart a measure of the main RC frequency, MAINF will carry the new frequency as soon as a low to high transition occurs on MAINFRDY flag.

The measure is performed on the main frequency (i.e. not limited to RC oscillator only) but if the main clock frequency source is the fast crystal oscillator, the restart of the measure is unneeded because of the well known stability of crystal oscillators.

27.2.16.9 PMC Clock Generator PLLA Register

Name: CKGR_PLLAR

Address: 0x400E0428

Access: Read-write

31	30	29	28	27	26	25	24
–	–	ONE	–	–	MULA		
23	22	21	20	19	18	17	16
MULA							
15	14	13	12	11	10	9	8
–	–	PLLACOUNT					
7	6	5	4	3	2	1	0
DIVA							

Possible limitations on PLLA input frequencies and multiplier factors should be checked before using the PMC.

Warning: Bit 29 must always be set to 1 when programming the CKGR_PLLAR register.

This register can only be written if the WPEN bit is cleared in [“PMC Write Protect Mode Register”](#) .

- **DIVA: Divider**

0 = Divider output is stuck at 0.

1 = Divider is bypassed (divide by 1)

2 up to 255 = clock is divided by DIVA

- **PLLACOUNT: PLLA Counter**

Specifies the number of Slow Clock cycles x8 before the LOCKA bit is set in PMC_SR after CKGR_PLLAR is written.

- **MULA: PLLA Multiplier**

0 = The PLLA is deactivated.

1 up to 62 = The PLLA Clock frequency is the PLLA input frequency multiplied by MULA + 1.

- **ONE: Must Be Set to 1**

Bit 29 must always be set to 1 when programming the CKGR_PLLAR register.



27.2.16.10 PMC Clock Generator PLLB Register

Name: CKGR_PLLBR

Address: 0x400E042C

Access: Read-write

31	30	29	28	27	26	25	24
–	–	–	–	–	MULB		
23	22	21	20	19	18	17	16
MULB							
15	14	13	12	11	10	9	8
–	–	PLLBCOUNT					
7	6	5	4	3	2	1	0
DIVB							

Possible limitations on PLLB input frequencies and multiplier factors should be checked before using the PMC.

This register can only be written if the WPEN bit is cleared in [“PMC Write Protect Mode Register”](#) .

- **DIVB: Divider**

0 = Divider output is stuck at 0.

1= Divider is bypassed (divide by 1)

2 up to 255 = clock is divided by DIVB

- **PLLBCOUNT: PLLB Counter**

Specifies the number of Slow Clock cycles x8 before the LOCKB bit is set in PMC_SR after CKGR_PLLBR is written.

- **MULB: PLLB Multiplier**

0 = The PLLB is deactivated.

1 up to 62 = The PLLB Clock frequency is the PLLB input frequency multiplied by MULB + 1.

27.2.16.11 PMC Master Clock Register

Name: PMC_MCKR

Address: 0x400E0430

Access: Read-write

31	30	29	28	27	26	25	24
–	–	–	–	–	–	–	–
23	22	21	20	19	18	17	16
–	–	–	–	–	–	–	–
15	14	13	12	11	10	9	8
–	–	PLLB DIV2	PLLA DIV2	–	–	–	–
7	6	5	4	3	2	1	0
–	PRES			–	–	CSS	

This register can only be written if the WPEN bit is cleared in “[PMC Write Protect Mode Register](#)” .

• CSS: Master Clock Source Selection

Value	Name	Description
0	SLOW_CLK	Slow Clock is selected
1	MAIN_CLK	Main Clock is selected
2	PLLA_CLK	PLLA Clock is selected
3	PLLB_CLK	PLLB Clock is selected

• PRES: Processor Clock Prescaler

Value	Name	Description
0	CLK_1	Selected clock
1	CLK_2	Selected clock divided by 2
2	CLK_4	Selected clock divided by 4
3	CLK_8	Selected clock divided by 8
4	CLK_16	Selected clock divided by 16
5	CLK_32	Selected clock divided by 32
6	CLK_64	Selected clock divided by 64
7	CLK_3	Selected clock divided by 3

• PLLADIV2: PLLA Divisor by 2

PLLADIV2	PLLA Clock Division
0	PLLA clock frequency is divided by 1.
1	PLLA clock frequency is divided by 2.



- **PLLBDIV2: PLLB Divisor by 2**

PLLBDIV2	PLLB Clock Division
0	PLLB clock frequency is divided by 1.
1	PLLB clock frequency is divided by 2.



27.2.16.12 PMC USB Clock Register

Name: PMC_USB

Address: 0x400E0438

Access: Read-write

31	30	29	28	27	26	25	24
–	–	–	–	–	–	–	–
23	22	21	20	19	18	17	16
–	–	–	–	–	–	–	–
15	14	13	12	11	10	9	8
–	–	–	–	USB DIV			
7	6	5	4	3	2	1	0
–	–	–	–	–	–	–	USBS

This register can only be written if the WPEN bit is cleared in [“PMC Write Protect Mode Register”](#) .

- **USBS: USB Input Clock Selection**

0 = USB Clock Input is PLLA.

1 = USB Clock Input is PLLB.

- **USB DIV: Divider for USB Clock.**

USB Clock is Input clock divided by USB DIV+1.

27.2.16.13 PMC Programmable Clock Register

Name: PMC_PCKx

Address: 0x400E0440

Access: Read-write

31	30	29	28	27	26	25	24
–	–	–	–	–	–	–	–
23	22	21	20	19	18	17	16
–	–	–	–	–	–	–	–
15	14	13	12	11	10	9	8
–	–	–	–	–	–	–	–
7	6	5	4	3	2	1	0
–	PRES			–	CSS		

This register can only be written if the WPEN bit is cleared in [“PMC Write Protect Mode Register”](#) .

- **CSS: Master Clock Source Selection**

Value	Name	Description
0	SLOW_CLK	Slow Clock is selected
1	MAIN_CLK	Main Clock is selected
2	PLLA_CLK	PLLA Clock is selected
3	PLLB_CLK	PLLB Clock is selected
4	MCK	Master Clock is selected

- **PRES: Programmable Clock Prescaler**

Value	Name	Description
0	CLK_1	Selected clock
1	CLK_2	Selected clock divided by 2
2	CLK_4	Selected clock divided by 4
3	CLK_8	Selected clock divided by 8
4	CLK_16	Selected clock divided by 16
5	CLK_32	Selected clock divided by 32
6	CLK_64	Selected clock divided by 64

27.2.16.14 PMC Interrupt Enable Register

Name: PMC_IER

Address: 0x400E0460

Access: Write-only

31	30	29	28	27	26	25	24
–	–	–	–	–	–	–	–
23	22	21	20	19	18	17	16
–	–	–	–	–	CFDEV	MOSCRCS	MOSCSELS
15	14	13	12	11	10	9	8
–	–	–	–	–	PCKRDY2	PCKRDY1	PCKRDY0
7	6	5	4	3	2	1	0
–	–	–	–	MCKRDY	LOCKB	LOCKA	MOSCXTS

- **MOSCXTS: Main Crystal Oscillator Status Interrupt Enable**
- **LOCKA: PLLA Lock Interrupt Enable**
- **LOCKB: PLLB Lock Interrupt Enable**
- **MCKRDY: Master Clock Ready Interrupt Enable**
- **PCKRDYx: Programmable Clock Ready x Interrupt Enable**
- **MOSCSELS: Main Oscillator Selection Status Interrupt Enable**
- **MOSCRCS: Main On-Chip RC Status Interrupt Enable**
- **CFDEV: Clock Failure Detector Event Interrupt Enable**



27.2.16.15 PMC Interrupt Disable Register

Name: PMC_IDR

Address: 0x400E0464

Access: Write-only

31	30	29	28	27	26	25	24
–	–	–	–	–	–	–	–
23	22	21	20	19	18	17	16
–	–	–	–	–	CFDEV	MOSCRCS	MOSCSELS
15	14	13	12	11	10	9	8
–	–	–	–	–	PCKRDY2	PCKRDY1	PCKRDY0
7	6	5	4	3	2	1	0
–	–	–	–	MCKRDY	LOCKB	LOCKA	MOSCXTS

- **MOSCXTS: Main Crystal Oscillator Status Interrupt Disable**
- **LOCKA: PLLA Lock Interrupt Disable**
- **LOCKB: PLLB Lock Interrupt Disable**
- **MCKRDY: Master Clock Ready Interrupt Disable**
- **PCKRDYx: Programmable Clock Ready x Interrupt Disable**
- **MOSCSELS: Main Oscillator Selection Status Interrupt Disable**
- **MOSCRCS: Main On-Chip RC Status Interrupt Disable**
- **CFDEV: Clock Failure Detector Event Interrupt Disable**

27.2.16.16 PMC Status Register

Name: PMC_SR

Address: 0x400E0468

Access: Read-only

31	30	29	28	27	26	25	24
–	–	–	–	–	–	–	–
23	22	21	20	19	18	17	16
–	–	–	FOS	CFDS	CFDEV	MOSCRCS	MOSCSELS
15	14	13	12	11	10	9	8
–	–	–	–	–	PCKRDY2	PCKRDY1	PCKRDY0
7	6	5	4	3	2	1	0
OSCSELS	–	–	–	MCKRDY	LOCKB	LOCKA	MOSCXTS

- **MOSCXTS: Main XTAL Oscillator Status**

0 = Main XTAL oscillator is not stabilized.

1 = Main XTAL oscillator is stabilized.

- **LOCKA: PLLA Lock Status**

0 = PLLA is not locked

1 = PLLA is locked.

- **LOCKB: PLLB Lock Status**

0 = PLLB is not locked

1 = PLLB is locked.

- **MCKRDY: Master Clock Status**

0 = Master Clock is not ready.

1 = Master Clock is ready.

- **OSCSELS: Slow Clock Oscillator Selection**

0 = Internal slow clock RC oscillator is selected.

1 = External slow clock 32 kHz oscillator is selected.

- **PCKRDYx: Programmable Clock Ready Status**

0 = Programmable Clock x is not ready.

1 = Programmable Clock x is ready.

- **MOSCSELS: Main Oscillator Selection Status**

0 = Selection is in progress.

1 = Selection is done.

- **MOSCRCS: Main On-Chip RC Oscillator Status**

0 = Main on-chip RC oscillator is not stabilized.

1 = Main on-chip RC oscillator is stabilized.

- **CFDEV: Clock Failure Detector Event**

0 = No clock failure detection of the main on-chip RC oscillator clock has occurred since the last read of PMC_SR.

1 = At least one clock failure detection of the main on-chip RC oscillator clock has occurred since the last read of PMC_SR.

- **CFDS: Clock Failure Detector Status**

0 = A clock failure of the main on-chip RC oscillator clock is not detected.

1 = A clock failure of the main on-chip RC oscillator clock is detected.

- **FOS: Clock Failure Detector Fault Output Status**

0 = The fault output of the clock failure detector is inactive.

1 = The fault output of the clock failure detector is active.

27.2.16.17 PMC Interrupt Mask Register

Name: PMC_IMR

Address: 0x400E046C

Access: Read-only

31	30	29	28	27	26	25	24
–	–	–	–	–	–	–	–
23	22	21	20	19	18	17	16
–	–	–	–	–	CFDEV	MOSCRCS	MOSCSELS
15	14	13	12	11	10	9	8
–	–	–	–	–	PCKRDY2	PCKRDY1	PCKRDY0
7	6	5	4	3	2	1	0
–	–	–	–	MCKRDY	LOCKB	LOCKA	MOSCXTS

- **MOSCXTS: Main Crystal Oscillator Status Interrupt Mask**
- **LOCKA: PLLA Lock Interrupt Mask**
- **LOCKB: PLLB Lock Interrupt Mask**
- **MCKRDY: Master Clock Ready Interrupt Mask**
- **PCKRDYx: Programmable Clock Ready x Interrupt Mask**
- **MOSCSELS: Main Oscillator Selection Status Interrupt Mask**
- **MOSCRCS: Main On-Chip RC Status Interrupt Mask**
- **CFDEV: Clock Failure Detector Event Interrupt Mask**

27.2.16.18 PMC Fast Startup Mode Register

Name: PMC_FSMR

Address: 0x400E0470

Access: Read-write

31	30	29	28	27	26	25	24
–	–	–	–	–	–	–	–
23	22	21	20	19	18	17	16
–	FLPM		–	–	USBAL	RTCAL	RTTAL
15	14	13	12	11	10	9	8
FSTT15	FSTT14	FSTT13	FSTT12	FSTT11	FSTT10	FSTT9	FSTT8
7	6	5	4	3	2	1	0
FSTT7	FSTT6	FSTT5	FSTT4	FSTT3	FSTT2	FSTT1	FSTT0

This register can only be written if the WPEN bit is cleared in [“PMC Write Protect Mode Register”](#) .

- **FSTT0 - FSTT15: Fast Startup Input Enable 0 to 15**

0 = The corresponding wake up input has no effect on the Power Management Controller.

1 = The corresponding wake up input enables a fast restart signal to the Power Management Controller.

- **RTTAL: RTT Alarm Enable**

0 = The RTT alarm has no effect on the Power Management Controller.

1 = The RTT alarm enables a fast restart signal to the Power Management Controller.

- **RTCAL: RTC Alarm Enable**

0 = The RTC alarm has no effect on the Power Management Controller.

1 = The RTC alarm enables a fast restart signal to the Power Management Controller.

- **USBAL: USB Alarm Enable**

0 = The USB alarm has no effect on the Power Management Controller.

1 = The USB alarm enables a fast restart signal to the Power Management Controller.

- **FLPM: Flash Low Power Mode**

Value	Name	Description
0	FLASH_STANDBY	Flash is in Standby Mode when system enters Wait Mode
1	FLASH_DEEP_POWERDOWN	Flash is in deep power down mode when system enters Wait Mode
2	FLASH_IDLE	idle mode

27.2.16.19 PMC Fast Startup Polarity Register

Name: PMC_FSPR

Address: 0x400E0474

Access: Read-write

31	30	29	28	27	26	25	24
–	–	–	–	–	–	–	–
23	22	21	20	19	18	17	16
–	–	–	–	–	–	–	–
15	14	13	12	11	10	9	8
FSTP15	FSTP14	FSTP13	FSTP12	FSTP11	FSTP10	FSTP9	FSTP8
7	6	5	4	3	2	1	0
FSTP7	FSTP6	FSTP5	FSTP4	FSTP3	FSTP2	FSTP1	FSTP0

This register can only be written if the WPEN bit is cleared in [“PMC Write Protect Mode Register”](#) .

- **FSTPx: Fast Startup Input Polarityx**

Defines the active polarity of the corresponding wake up input. If the corresponding wake up input is enabled and at the FSTP level, it enables a fast restart signal.

27.2.16.20 *PMC Fault Output Clear Register*

Name: PMC_FOCR

Address: 0x400E0478

Access: Write-only

31	30	29	28	27	26	25	24
-	-	-	-	-	-	-	-
23	22	21	20	19	18	17	16
-	-	-	-	-	-	-	-
15	14	13	12	11	10	9	8
-	-	-	-	-	-	-	-
7	6	5	4	3	2	1	0
-	-	-	-	-	-	-	FOCLR

- **FOCLR: Fault Output Clear**

Clears the clock failure detector fault output.

27.2.16.21 PMC Write Protect Mode Register

Name: PMC_WPMR

Address: 0x400E04E4

Access: Read-write

Reset: See [Table 27-3](#)

31	30	29	28	27	26	25	24
WPKEY							
23	22	21	20	19	18	17	16
WPKEY							
15	14	13	12	11	10	9	8
WPKEY							
7	6	5	4	3	2	1	0
-	-	-	-	-	-	-	WPEN

- **WPEN: Write Protect Enable**

0 = Disables the Write Protect if WPKEY corresponds to 0x504D43 (“PMC” in ASCII).

1 = Enables the Write Protect if WPKEY corresponds to 0x504D43 (“PMC” in ASCII).

Protects the registers:

“[PMC System Clock Enable Register](#)”

“[PMC System Clock Disable Register](#)”

“[PMC Peripheral Clock Enable Register 0](#)”

“[PMC Peripheral Clock Disable Register 0](#)”

“[PMC Clock Generator Main Oscillator Register](#)”

“[PMC Clock Generator PLLA Register](#)”

“[PMC Clock Generator PLLB Register](#)”

“[PMC Master Clock Register](#)”

“[PMC USB Clock Register](#)”

“[PMC Programmable Clock Register](#)”

“[PMC Fast Startup Mode Register](#)”

“[PMC Fast Startup Polarity Register](#)”

“[PMC Peripheral Clock Enable Register 1](#)”

“[PMC Peripheral Clock Disable Register 1](#)”

“[PMC Oscillator Calibration Register](#)”

- **WPKEY: Write Protect KEY**

Should be written at value 0x504D43 (“PMC” in ASCII). Writing any other value in this field aborts the write operation of the WPEN bit. Always reads as 0.

27.2.16.22 PMC Write Protect Status Register

Name: PMC_WPSR

Address: 0x400E04E8

Access: Read-only

Reset: See [Table 27-3](#)

31	30	29	28	27	26	25	24
-	-	-	-	-	-	-	-
23	22	21	20	19	18	17	16
WPVSR							
15	14	13	12	11	10	9	8
WPVSR							
7	6	5	4	3	2	1	0
-	-	-	-	-	-	-	WPVS

- **WPVS: Write Protect Violation Status**

0 = No Write Protect Violation has occurred since the last read of the PMC_WPSR register.

1 = A Write Protect Violation has occurred since the last read of the PMC_WPSR register. If this violation is an unauthorized attempt to write a protected register, the associated violation is reported into field WPVSR.

- **WPVSR: Write Protect Violation Source**

When WPVS is active, this field indicates the write-protected register (through address offset or code) in which a write access has been attempted.

Reading PMC_WPSR automatically clears all fields.

27.2.16.23 PMC Peripheral Clock Enable Register 1

Name: PMC_PCER1

Address: 0x400E0500

Access: Write-only

31	30	29	28	27	26	25	24
–	–	–	–	–	–	–	–
23	22	21	20	19	18	17	16
–	–	–	–	–	–	–	–
15	14	13	12	11	10	9	8
–	–	–	–	–	–	–	–
7	6	5	4	3	2	1	0
–	–	–	–	–	PID34	PID33	PID32

This register can only be written if the WPEN bit is cleared in [“PMC Write Protect Mode Register”](#) .

- **PIDx: Peripheral Clock x Enable**

0 = No effect.

1 = Enables the corresponding peripheral clock.

- Notes:
1. To get PIDx, refer to identifiers as defined in the section “Peripheral Identifiers” in the product datasheet.
 2. Programming the control bits of the Peripheral ID that are not implemented has no effect on the behavior of the PMC.



27.2.16.24 PMC Peripheral Clock Disable Register 1

Name: PMC_PCDR1

Address: 0x400E0504

Access: Write-only

31	30	29	28	27	26	25	24
–	–	–	–	–	–	–	–
23	22	21	20	19	18	17	16
–	–	–	–	–	–	–	–
15	14	13	12	11	10	9	8
–	–	–	–	–	–	–	–
7	6	5	4	3	2	1	0
–	–	–	–	–	PID34	PID33	PID32

This register can only be written if the WPEN bit is cleared in “[PMC Write Protect Mode Register](#)” on page 521.

- **PIDx: Peripheral Clock x Disable**

0 = No effect.

1 = Disables the corresponding peripheral clock.

Note: To get PIDx, refer to identifiers as defined in the section “Peripheral Identifiers” in the product datasheet.

27.2.16.25 PMC Peripheral Clock Status Register 1

Name: PMC_PCSR1

Address: 0x400E0508

Access: Read-only

31	30	29	28	27	26	25	24
–	–	–	–	–	–	–	–
23	22	21	20	19	18	17	16
–	–	–	–	–	–	–	–
15	14	13	12	11	10	9	8
–	–	–	–	–	–	–	–
7	6	5	4	3	2	1	0
–	–	–	–	–	PID34	PID33	PID32

- **PIDx: Peripheral Clock x Status**

0 = The corresponding peripheral clock is disabled.

1 = The corresponding peripheral clock is enabled.

Note: To get PIDx, refer to identifiers as defined in the section “Peripheral Identifiers” in the product datasheet.

27.2.16.26 PMC Oscillator Calibration Register

Name: PMC_OCR
Address: 0x400E0510
Access: Read-write

31	30	29	28	27	26	25	24
–	–	–	–	–	–	–	–
23	22	21	20	19	18	17	16
SEL12	CAL12						
15	14	13	12	11	10	9	8
SEL8	CAL8						
7	6	5	4	3	2	1	0
SEL4	CAL4						

This register can only be written if the WPEN bit is cleared in “[PMC Write Protect Mode Register](#)” .

- **CAL4: RC Oscillator Calibration bits for 4 Mhz**
 Calibration bits applied to the RC Oscillator when SEL4 is set.
- **SEL4: Selection of RC Oscillator Calibration bits for 4 Mhz**
 0 = Default value stored in Flash memory.
 1 = Value written by user in CAL4 field of this register.
- **CAL8: RC Oscillator Calibration bits for 8 Mhz**
 Calibration bits applied to the RC Oscillator when SEL8 is set.
- **SEL8: Selection of RC Oscillator Calibration bits for 8 Mhz**
 0 = Factory determined value stored in Flash memory.
 1 = Value written by user in CAL8 field of this register.
- **CAL12: RC Oscillator Calibration bits for 12 Mhz**
 Calibration bits applied to the RC Oscillator when SEL12 is set.
- **SEL12: Selection of RC Oscillator Calibration bits for 12 Mhz**
 0 = Factory determined value stored in Flash memory.
 1 = Value written by user in CAL12 field of this register.

28. Chip Identifier (CHIPID)

28.1 Description

The Chip Identifier (CHIPID) registers permit recognition of the device and its revision. These registers provide the sizes and types of the on-chip memories, as well as the set of embedded peripherals.

Two chip identifier registers are embedded: CHIPID_CIDR (Chip ID Register) and CHIPID_EXID (Extension ID). Both registers contain a hard-wired value that is read-only. The first register contains the following fields:

- EXT - shows the use of the extension identifier register
- NVPTYP and NVPSIZ - identifies the type of embedded non-volatile memory and its size
- ARCH - identifies the set of embedded peripherals
- SRAMSIZ - indicates the size of the embedded SRAM
- EPROC - indicates the embedded ARM processor
- VERSION - gives the revision of the silicon

The second register is device-dependent and reads 0 if the bit EXT is 0.

28.2 Embedded Characteristics

- Chip ID Registers
 - Identification of the Device Revision, Sizes of the Embedded Memories, Set of Peripherals, Embedded Processor

Table 28-1. SAM4S Chip IDs Register

Chip Name	Flash Size (KBytes)	RAM Size (KBytes)	Pin Count	CHIPID_CIDR	CHIPID_EXID
SAM4SD32C	2*1024	160	100	0X29A7_0EE0	
SAM4SD32B	2*1024	160	64	0X2997_0EE0	
SAM4SD16C	2*512	160	100	0X29A7_0CE0	
SAM4SD16B	2*512	160	64	0X2997_0CE0	
SAM4SA16C	1024	160	100	0X28A7_0CE0	0x0
SAM4SA16B	1024	160	64	0X2897_0CE0	0x0
SAM4S16B	1024	128	64	0x289C_0CE0	0x0
SAM4S16C	1024	128	100	0x28AC_0CE0	0x0
SAM4S8B	512	128	64	0x289C_0AE0	0x0
SAM4S8C	512	128	100	0x28AC_0AE0	0x0

28.3 Chip Identifier (CHIPID) User Interface**Table 28-2.** Register Mapping

Offset	Register	Name	Access	Reset
0x0	Chip ID Register	CHIPID_CIDR	Read-only	–
0x4	Chip ID Extension Register	CHIPID_EXID	Read-only	–



28.3.1 Chip ID Register

Name: CHIPID_CIDR

Address: 0x400E0740

Access: Read-only

31	30	29	28	27	26	25	24
EXT	NVPTYP				ARCH		
23	22	21	20	19	18	17	16
ARCH				SRAMSIZ			
15	14	13	12	11	10	9	8
NVPSIZ2				NVPSIZ			
7	6	5	4	3	2	1	0
EPROC				VERSION			

• **VERSION: Version of the Device**

Current version of the device.

• **EPROC: Embedded Processor**

Value	Name	Description
1	ARM946ES	ARM946ES
2	ARM7TDMI	ARM7TDMI
3	CM3	Cortex-M3
4	ARM920T	ARM920T
5	ARM926EJS	ARM926EJS
6	CA5	Cortex-A5
7	CM4	Cortex-M4

• **NVPSIZ: Nonvolatile Program Memory Size**

Value	Name	Description
0	NONE	None
1	8K	8K bytes
2	16K	16K bytes
3	32K	32K bytes
4		Reserved
5	64K	64K bytes
6		Reserved
7	128K	128K bytes
8		Reserved
9	256K	256K bytes
10	512K	512K bytes
11		Reserved
12	1024K	1024K bytes

Value	Name	Description
13		Reserved
14	2048K	2048K bytes
15		Reserved

- **NVPSIZ2 Second Nonvolatile Program Memory Size**

Value	Name	Description
0	NONE	None
1	8K	8K bytes
2	16K	16K bytes
3	32K	32K bytes
4		Reserved
5	64K	64K bytes
6		Reserved
7	128K	128K bytes
8		Reserved
9	256K	256K bytes
10	512K	512K bytes
11		Reserved
12	1024K	1024K bytes
13		Reserved
14	2048K	2048K bytes
15		Reserved

- **SRAMSIZ: Internal SRAM Size**

Value	Name	Description
0	48K	48K bytes
1	1K	1K bytes
2	2K	2K bytes
3	6K	6K bytes
4	24K	24K bytes
5	4K	4K bytes
6	80K	80K bytes
7	160K	160K bytes
8	8K	8K bytes
9	16K	16K bytes
10	32K	32K bytes
11	64K	64K bytes
12	128K	128K bytes

Value	Name	Description
13	256K	256K bytes
14	96K	96K bytes
15	512K	512K bytes

• **ARCH: Architecture Identifier**

Value	Name	Description
0x19	AT91SAM9xx	AT91SAM9xx Series
0x29	AT91SAM9EXxx	AT91SAM9EXxx Series
0x34	AT91x34	AT91x34 Series
0x37	CAP7	CAP7 Series
0x39	CAP9	CAP9 Series
0x3B	CAP11	CAP11 Series
0x40	AT91x40	AT91x40 Series
0x42	AT91x42	AT91x42 Series
0x55	AT91x55	AT91x55 Series
0x60	AT91SAM7Axx	AT91SAM7Axx Series
0x61	AT91SAM7AQxx	AT91SAM7AQxx Series
0x63	AT91x63	AT91x63 Series
0x70	AT91SAM7Sxx	AT91SAM7Sxx Series
0x71	AT91SAM7XCxx	AT91SAM7XCxx Series
0x72	AT91SAM7SExx	AT91SAM7SExx Series
0x73	AT91SAM7Lxx	AT91SAM7Lxx Series
0x75	AT91SAM7Xxx	AT91SAM7Xxx Series
0x76	AT91SAM7SLxx	AT91SAM7SLxx Series
0x80	SAM3UxC	SAM3UxC Series (100-pin version)
0x81	SAM3UxE	SAM3UxE Series (144-pin version)
0x83	SAM3A/SAM4A xC	SAM3AxC or SAM4AxC Series (100-pin version)
0x84	SAM3X/SAM4X xC	SAM3XxC or SAM4XxC Series (100-pin version)
0x85	SAM3X/SAM4X xE	SAM3XxE or SAM4XxE Series (144-pin version)
0x86	SAM3X/SAM4X xG	SAM3XxG or SAM4XxG Series (208/217-pin version)
0x88	SAM3S/SAM4S xA	SAM3SxA or SAM4SxA Series (48-pin version)
0x89	SAM3S/SAM4S xB	SAM3SxB or SAM4SxB Series (64-pin version)
0x8A	SAM3S/SAM4S xC	SAM3SxC or SAM4SxC Series (100-pin version)
0x92	AT91x92	AT91x92 Series
0x93	SAM3NxA	SAM3Nx A Series (48-pin version)
0x94	SAM3Nx B	SAM3Nx B Series (64-pin version)
0x95	SAM3Nx C	SAM3Nx C Series (100-pin version)
0x99	SAM3SDxB	SAM3SDxB Series (64-pin version)

Value	Name	Description
0x9A	SAM3SDxC	SAM3SDxC Series (100-pin version)
0xA5	SAM5A	SAM5A
0xF0	AT75Cxx	AT75Cxx Series

- **NVPTYP: Nonvolatile Program Memory Type**

Value	Name	Description
0	ROM	ROM
1	ROMLESS	ROMless or on-chip Flash
4	SRAM	SRAM emulating ROM
2	FLASH	Embedded Flash Memory
3	ROM_FLASH	ROM and Embedded Flash Memory NVPSIZ is ROM size NVPSIZ2 is Flash size

- **EXT: Extension Flag**

0 = Chip ID has a single register definition without extension

1 = An extended Chip ID exists.

28.3.2 Chip ID Extension Register

Name: CHIPID_EXID

Address: 0x400E0744

Access: Read-only

31	30	29	28	27	26	25	24
EXID							
23	22	21	20	19	18	17	16
EXID							
15	14	13	12	11	10	9	8
EXID							
7	6	5	4	3	2	1	0
EXID							

- **EXID: Chip ID Extension**

Reads 0 if the bit EXT in CHIPID_CIDR is 0.

29. Parallel Input/Output Controller (PIO)

29.1 Description

The Parallel Input/Output Controller (PIO) manages up to 32 fully programmable input/output lines. Each I/O line may be dedicated as a general-purpose I/O or be assigned to a function of an embedded peripheral. This assures effective optimization of the pins of a product.

Each I/O line is associated with a bit number in all of the 32-bit registers of the 32-bit wide User Interface.

Each I/O line of the PIO Controller features:

- An input change interrupt enabling level change detection on any I/O line.
- Additional Interrupt modes enabling rising edge, falling edge, low level or high level detection on any I/O line.
- A glitch filter providing rejection of glitches lower than one-half of PIO clock cycle.
- A debouncing filter providing rejection of unwanted pulses from key or push button operations.
- Multi-drive capability similar to an open drain I/O line.
- Control of the pull-up and pull-down of the I/O line.
- Input visibility and output control.

The PIO Controller also features a synchronous output providing up to 32 bits of data output in a single write operation.

An 8-bit parallel capture mode is also available which can be used to interface a CMOS digital image sensor, an ADC, a DSP synchronous port in synchronous mode, etc...

29.2 Embedded Characteristics

- Up to 32 Programmable I/O Lines
- Fully Programmable through Set/Clear Registers
- Multiplexing of Four Peripheral Functions per I/O Line
- For each I/O Line (Whether Assigned to a Peripheral or Used as General Purpose I/O)
 - Input Change Interrupt
 - Programmable Glitch Filter
 - Programmable Debouncing Filter
 - Multi-drive Option Enables Driving in Open Drain
 - Programmable Pull Up on Each I/O Line
 - Pin Data Status Register, Supplies Visibility of the Level on the Pin at Any Time
 - Additional Interrupt Modes on a Programmable Event: Rising Edge, Falling Edge, Low Level or High Level
 - Lock of the Configuration by the Connected Peripheral
- Synchronous Output, Provides Set and Clear of Several I/O lines in a Single Write
- Write Protect Registers
- Programmable Schmitt Trigger Inputs
- Parallel Capture Mode

- Can be used to interface a CMOS digital image sensor, an ADC....
- One Clock, 8-bit Parallel Data and Two Data Enable on I/O Lines
- Data Can be Sampled one time of out two (For Chrominance Sampling Only)
- Supports Connection of one Peripheral DMA Controller Channel (PDC) Which Offers Buffer Reception Without Processor Intervention

29.3 Block Diagram

Figure 29-1. Block Diagram

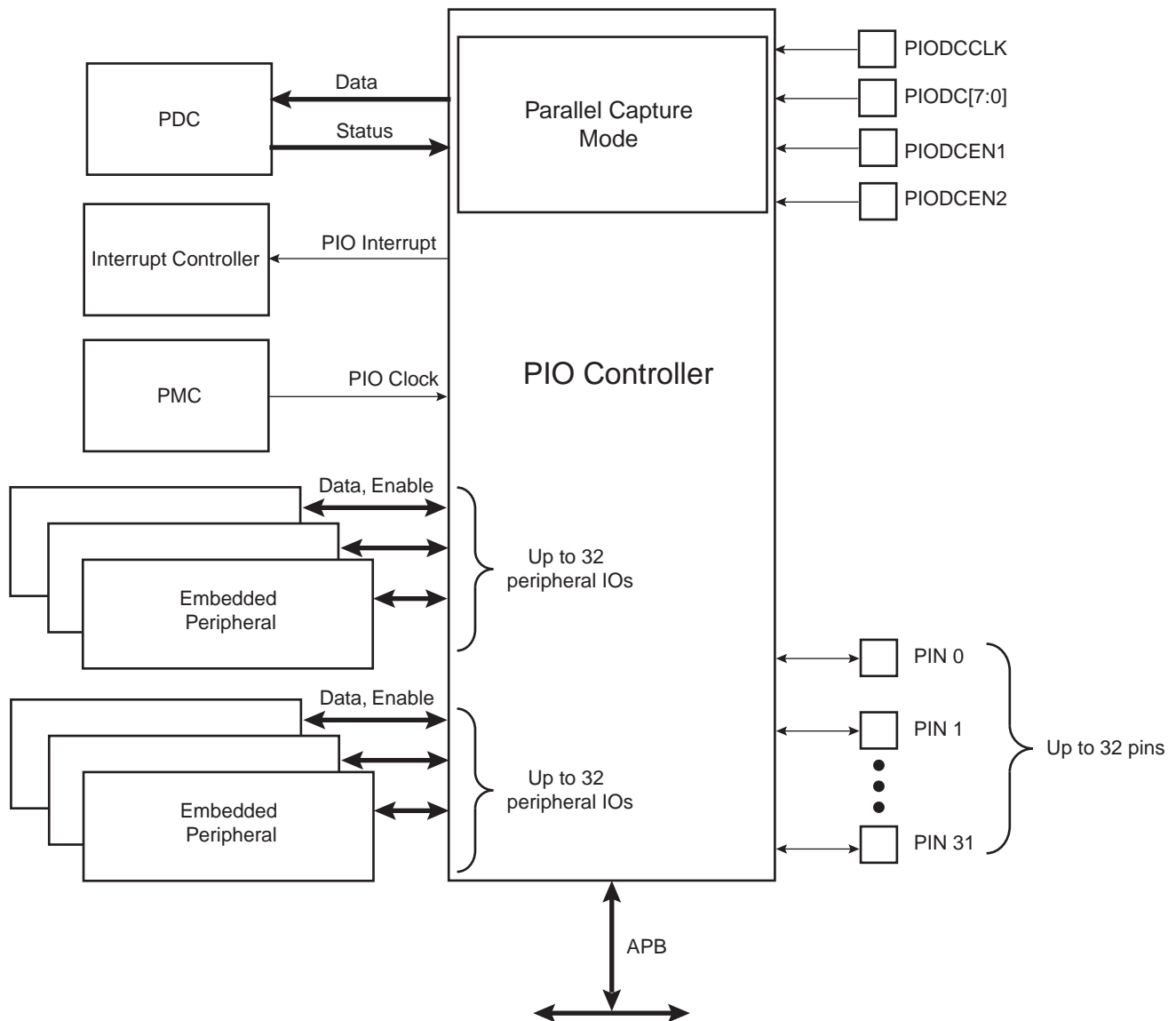
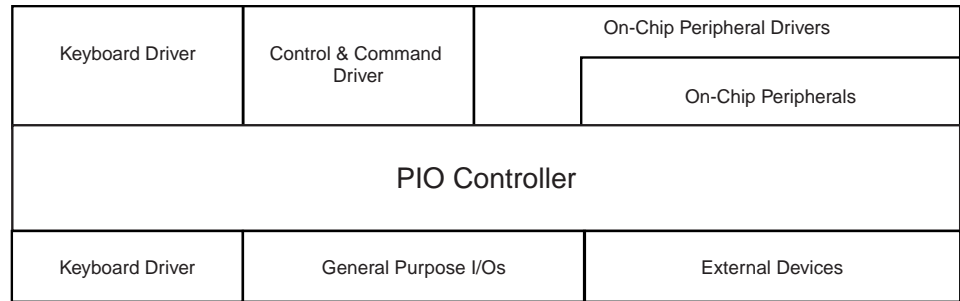

Table 29-1. Signal Description

Signal Name	Signal Description	Signal Type
PIODCCLK	Parallel Capture Mode Clock	Input
PIODC[7:0]	Parallel Capture Mode Data	Input
PIODCEN1	Parallel Capture Mode Data Enable 1	Input
PIODCEN2	Parallel Capture Mode Data Enable 2	Input

Figure 29-2. Application Block Diagram



29.4 Product Dependencies

29.4.1 Pin Multiplexing

Each pin is configurable, according to product definition as either a general-purpose I/O line only, or as an I/O line multiplexed with one or two peripheral I/Os. As the multiplexing is hardware defined and thus product-dependent, the hardware designer and programmer must carefully determine the configuration of the PIO controllers required by their application. When an I/O line is general-purpose only, i.e. not multiplexed with any peripheral I/O, programming of the PIO Controller regarding the assignment to a peripheral has no effect and only the PIO Controller can control how the pin is driven by the product.

29.4.2 Power Management

The Power Management Controller controls the PIO Controller clock in order to save power. Writing any of the registers of the user interface does not require the PIO Controller clock to be enabled. This means that the configuration of the I/O lines does not require the PIO Controller clock to be enabled.

However, when the clock is disabled, not all of the features of the PIO Controller are available, including glitch filtering. Note that the Input Change Interrupt, Interrupt Modes on a programmable event and the read of the pin level require the clock to be validated.

After a hardware reset, the PIO clock is disabled by default.

The user must configure the Power Management Controller before any access to the input line information.

29.4.3 Interrupt Generation

The PIO Controller is connected on one of the sources of the Nested Vectored Interrupt Controller (NVIC). Using the PIO Controller requires the NVIC to be programmed first.

The PIO Controller interrupt can be generated only if the PIO Controller clock is enabled.

29.5 Functional Description

The PIO Controller features up to 32 fully-programmable I/O lines. Most of the control logic associated to each I/O is represented in Figure 29-3. In this description each signal shown represents but one of up to 32 possible indexes.

Figure 29-3. I/O Line Control Logic

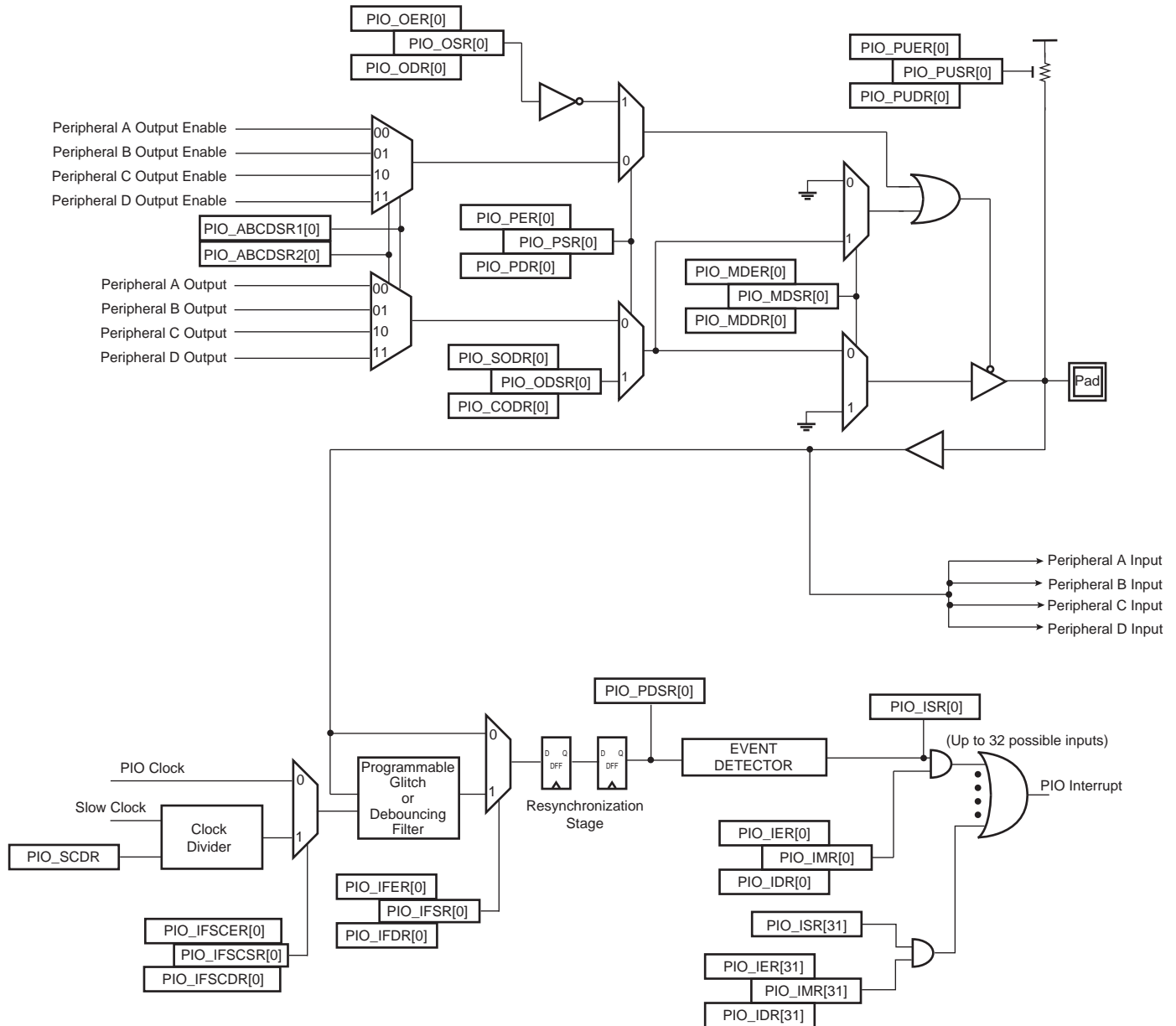

29.5.1 Pull-up and Pull-down Resistor Control

Each I/O line is designed with an embedded pull-up resistor and an embedded pull-down resistor. The pull-up resistor can be enabled or disabled by writing respectively PIO_PUER (Pull-up Enable Register) and PIO_PUDR (Pull-up Disable Resistor). Writing in these registers results in setting or clearing the corresponding bit in PIO_PUSR (Pull-up Status Register). Reading a 1 in PIO_PUSR means the pull-up is disabled and reading a 0 means the pull-up is enabled. The

pull-down resistor can be enabled or disabled by writing respectively PIO_PPDER (Pull-down Enable Register) and PIO_PPDDR (Pull-down Disable Resistor). Writing in these registers results in setting or clearing the corresponding bit in PIO_PPDSR (Pull-down Status Register). Reading a 1 in PIO_PPDSR means the pull-up is disabled and reading a 0 means the pull-down is enabled.

Enabling the pull-down resistor while the pull-up resistor is still enabled is not possible. In this case, the write of PIO_PPDER for the concerned I/O line is discarded. Likewise, enabling the pull-up resistor while the pull-down resistor is still enabled is not possible. In this case, the write of PIO_PUER for the concerned I/O line is discarded.

Control of the pull-up resistor is possible regardless of the configuration of the I/O line.

After reset, all of the pull-ups are enabled, i.e. PIO_PUSR resets at the value 0x0, and all the pull-downs are disabled, i.e. PIO_PPDSR resets at the value 0xFFFFFFFF.

29.5.2 I/O Line or Peripheral Function Selection

When a pin is multiplexed with one or two peripheral functions, the selection is controlled with the registers PIO_PER (PIO Enable Register) and PIO_PDR (PIO Disable Register). The register PIO_PSR (PIO Status Register) is the result of the set and clear registers and indicates whether the pin is controlled by the corresponding peripheral or by the PIO Controller. A value of 0 indicates that the pin is controlled by the corresponding on-chip peripheral selected in the PIO_ABCDSR1 and PIO_ABCDSR2 (ABCD Select Registers). A value of 1 indicates the pin is controlled by the PIO controller.

If a pin is used as a general purpose I/O line (not multiplexed with an on-chip peripheral), PIO_PER and PIO_PDR have no effect and PIO_PSR returns 1 for the corresponding bit.

After reset, most generally, the I/O lines are controlled by the PIO controller, i.e. PIO_PSR resets at 1. However, in some events, it is important that PIO lines are controlled by the peripheral (as in the case of memory chip select lines that must be driven inactive after reset or for address lines that must be driven low for booting out of an external memory). Thus, the reset value of PIO_PSR is defined at the product level, depending on the multiplexing of the device.

29.5.3 Peripheral A or B or C or D Selection

The PIO Controller provides multiplexing of up to four peripheral functions on a single pin. The selection is performed by writing PIO_ABCDSR1 and PIO_ABCDSR2 (ABCD Select Registers).

For each pin:

- the corresponding bit at level 0 in PIO_ABCDSR1 and the corresponding bit at level 0 in PIO_ABCDSR2 means peripheral A is selected.
- the corresponding bit at level 1 in PIO_ABCDSR1 and the corresponding bit at level 0 in PIO_ABCDSR2 means peripheral B is selected.
- the corresponding bit at level 0 in PIO_ABCDSR1 and the corresponding bit at level 1 in PIO_ABCDSR2 means peripheral C is selected.
- the corresponding bit at level 1 in PIO_ABCDSR1 and the corresponding bit at level 1 in PIO_ABCDSR2 means peripheral D is selected.

Note that multiplexing of peripheral lines A, B, C and D only affects the output line. The peripheral input lines are always connected to the pin input.

After reset, PIO_ABCDSR1 and PIO_ABCDSR2 are 0, thus indicating that all the PIO lines are configured on peripheral A. However, peripheral A generally does not drive the pin as the PIO Controller resets in I/O line mode.

Writing in PIO_ABCDSR1 and PIO_ABCDSR2 manages the multiplexing regardless of the configuration of the pin. However, assignment of a pin to a peripheral function requires a write in the peripheral selection registers (PIO_ABCDSR1 and PIO_ABCDSR2) in addition to a write in PIO_PDR.

29.5.4 Output Control

When the I/O line is assigned to a peripheral function, i.e. the corresponding bit in PIO_PSR is at 0, the drive of the I/O line is controlled by the peripheral. Peripheral A or B or C or D depending on the value in PIO_ABCDSR1 and PIO_ABCDSR2 (ABCD Select Registers) determines whether the pin is driven or not.

When the I/O line is controlled by the PIO controller, the pin can be configured to be driven. This is done by writing PIO_OER (Output Enable Register) and PIO_ODR (Output Disable Register). The results of these write operations are detected in PIO_OSR (Output Status Register). When a bit in this register is at 0, the corresponding I/O line is used as an input only. When the bit is at 1, the corresponding I/O line is driven by the PIO controller.

The level driven on an I/O line can be determined by writing in PIO_SODR (Set Output Data Register) and PIO_CODR (Clear Output Data Register). These write operations respectively set and clear PIO_ODSR (Output Data Status Register), which represents the data driven on the I/O lines. Writing in PIO_OER and PIO_ODR manages PIO_OSR whether the pin is configured to be controlled by the PIO controller or assigned to a peripheral function. This enables configuration of the I/O line prior to setting it to be managed by the PIO Controller.

Similarly, writing in PIO_SODR and PIO_CODR effects PIO_ODSR. This is important as it defines the first level driven on the I/O line.

29.5.5 Synchronous Data Output

Clearing one (or more) PIO line(s) and setting another one (or more) PIO line(s) synchronously cannot be done by using PIO_SODR and PIO_CODR registers. It requires two successive write operations into two different registers. To overcome this, the PIO Controller offers a direct control of PIO outputs by single write access to PIO_ODSR (Output Data Status Register). Only bits unmasked by PIO_OWSR (Output Write Status Register) are written. The mask bits in PIO_OWSR are set by writing to PIO_OWER (Output Write Enable Register) and cleared by writing to PIO_OWDR (Output Write Disable Register).

After reset, the synchronous data output is disabled on all the I/O lines as PIO_OWSR resets at 0x0.

29.5.6 Multi Drive Control (Open Drain)

Each I/O can be independently programmed in Open Drain by using the Multi Drive feature. This feature permits several drivers to be connected on the I/O line which is driven low only by each device. An external pull-up resistor (or enabling of the internal one) is generally required to guarantee a high level on the line.

The Multi Drive feature is controlled by PIO_MDER (Multi-driver Enable Register) and PIO_MDDR (Multi-driver Disable Register). The Multi Drive can be selected whether the I/O line is controlled by the PIO controller or assigned to a peripheral function. PIO_MDSR (Multi-driver Status Register) indicates the pins that are configured to support external drivers.

After reset, the Multi Drive feature is disabled on all pins, i.e. PIO_MDSR resets at value 0x0.

29.5.7 Output Line Timings

Figure 29-4 shows how the outputs are driven either by writing PIO_SODR or PIO_CODR, or by directly writing PIO_ODSR. This last case is valid only if the corresponding bit in PIO_OWSR is set. Figure 29-4 also shows when the feedback in PIO_PDSR is available.

Figure 29-4. Output Line Timings

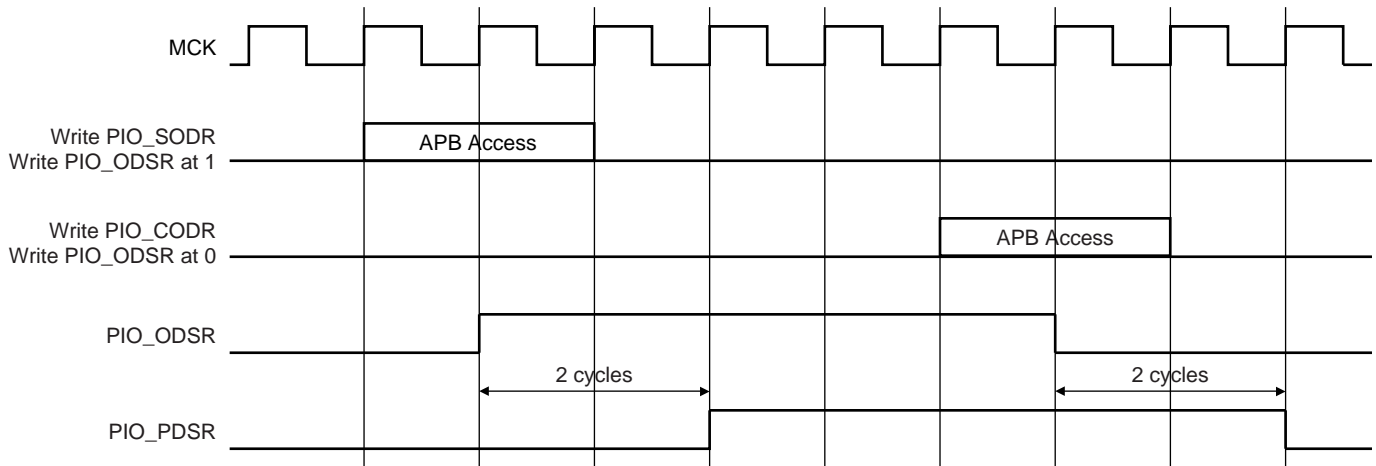

29.5.8 Inputs

The level on each I/O line can be read through PIO_PDSR (Pin Data Status Register). This register indicates the level of the I/O lines regardless of their configuration, whether uniquely as an input or driven by the PIO controller or driven by a peripheral.

Reading the I/O line levels requires the clock of the PIO controller to be enabled, otherwise PIO_PDSR reads the levels present on the I/O line at the time the clock was disabled.

29.5.9 Input Glitch and Debouncing Filters

Optional input glitch and debouncing filters are independently programmable on each I/O line.

The glitch filter can filter a glitch with a duration of less than 1/2 Master Clock (MCK) and the debouncing filter can filter a pulse of less than 1/2 Period of a Programmable Divided Slow Clock.

The selection between glitch filtering or debounce filtering is done by writing in the registers PIO_IFSCDR (PIO Input Filter Slow Clock Disable Register) and PIO_IFSCER (PIO Input Filter Slow Clock Enable Register). Writing PIO_IFSCDR and PIO_IFSCER respectively, sets and clears bits in PIO_IFSCSR.

The current selection status can be checked by reading the register PIO_IFSCSR (Input Filter Slow Clock Status Register).

- If PIO_IFSCSR[i] = 0: The glitch filter can filter a glitch with a duration of less than 1/2 Period of Master Clock.
- If PIO_IFSCSR[i] = 1: The debouncing filter can filter a pulse with a duration of less than 1/2 Period of the Programmable Divided Slow Clock.

For the debouncing filter, the Period of the Divided Slow Clock is performed by writing in the DIV field of the PIO_SCDR (Slow Clock Divider Register)

$$Tdiv_slclk = ((DIV+1)*2).Tslow_clock$$

When the glitch or debouncing filter is enabled, a glitch or pulse with a duration of less than 1/2 Selected Clock Cycle (Selected Clock represents MCK or Divided Slow Clock depending on PIO_IFSCDR and PIO_IFSCER programming) is automatically rejected, while a pulse with a duration of 1 Selected Clock (MCK or Divided Slow Clock) cycle or more is accepted. For pulse durations between 1/2 Selected Clock cycle and 1 Selected Clock cycle the pulse may or may not be taken into account, depending on the precise timing of its occurrence. Thus for a pulse to be visible it must exceed 1 Selected Clock cycle, whereas for a glitch to be reliably filtered out, its duration must not exceed 1/2 Selected Clock cycle.

The filters also introduce some latencies, this is illustrated in [Figure 29-5](#) and [Figure 29-6](#).

The glitch filters are controlled by the register set: PIO_IFER (Input Filter Enable Register), PIO_IFDR (Input Filter Disable Register) and PIO_IFSR (Input Filter Status Register). Writing PIO_IFER and PIO_IFDR respectively sets and clears bits in PIO_IFSR. This last register enables the glitch filter on the I/O lines.

When the glitch and/or debouncing filter is enabled, it does not modify the behavior of the inputs on the peripherals. It acts only on the value read in PIO_PDSR and on the input change interrupt detection. The glitch and debouncing filters require that the PIO Controller clock is enabled.

Figure 29-5. Input Glitch Filter Timing

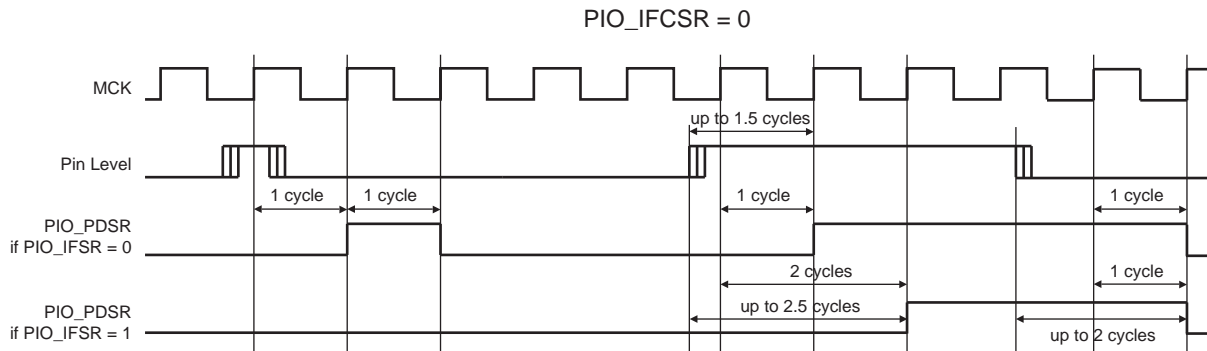
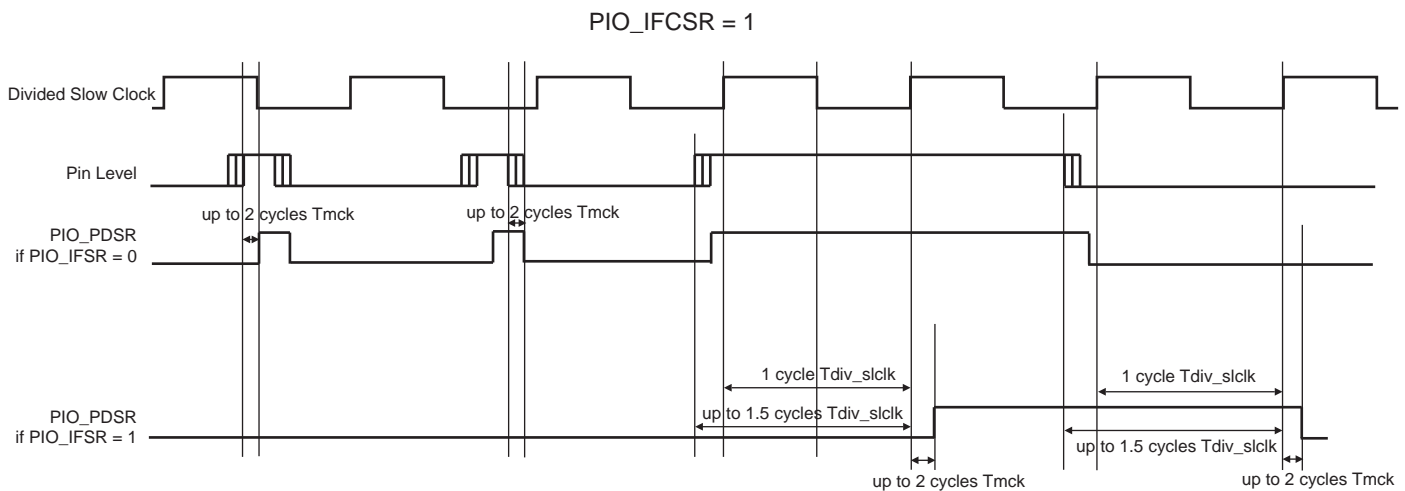

Figure 29-6. Input Debouncing Filter Timing



29.5.10 Input Edge/Level Interrupt

The PIO Controller can be programmed to generate an interrupt when it detects an edge or a level on an I/O line. The Input Edge/Level Interrupt is controlled by writing PIO_IER (Interrupt Enable Register) and PIO_IDR (Interrupt Disable Register), which respectively enable and disable the input change interrupt by setting and clearing the corresponding bit in PIO_IMR (Interrupt Mask Register). As Input change detection is possible only by comparing two successive samplings of the input of the I/O line, the PIO Controller clock must be enabled. The Input Change Interrupt is available, regardless of the configuration of the I/O line, i.e. configured as an input only, controlled by the PIO Controller or assigned to a peripheral function.

By default, the interrupt can be generated at any time an edge is detected on the input.

Some additional Interrupt modes can be enabled/disabled by writing in the PIO_AIMER (Additional Interrupt Modes Enable Register) and PIO_AIMDR (Additional Interrupt Modes Disable Register). The current state of this selection can be read through the PIO_AIMMR (Additional Interrupt Modes Mask Register)

These Additional Modes are:

- Rising Edge Detection
- Falling Edge Detection
- Low Level Detection
- High Level Detection

In order to select an Additional Interrupt Mode:

- The type of event detection (Edge or Level) must be selected by writing in the set of registers; PIO_ESR (Edge Select Register) and PIO_LSR (Level Select Register) which enable respectively, the Edge and Level Detection. The current status of this selection is accessible through the PIO_ELSR (Edge/Level Status Register).
- The Polarity of the event detection (Rising/Falling Edge or High/Low Level) must be selected by writing in the set of registers; PIO_FELLSR (Falling Edge /Low Level Select Register) and PIO_REHLSR (Rising Edge/High Level Select Register) which allow to select Falling or Rising Edge (if Edge is selected in the PIO_ELSR) Edge or High or Low Level Detection (if Level is selected in the PIO_ELSR). The current status of this selection is accessible through the PIO_FRLHSR (Fall/Rise - Low/High Status Register).

When an input Edge or Level is detected on an I/O line, the corresponding bit in PIO_ISR (Interrupt Status Register) is set. If the corresponding bit in PIO_IMR is set, the PIO Controller interrupt line is asserted. The interrupt signals of the thirty-two channels are ORed-wired together to generate a single interrupt signal to the Nested Vector Interrupt Controller (NVIC).

When the software reads PIO_ISR, all the interrupts are automatically cleared. This signifies that all the interrupts that are pending when PIO_ISR is read must be handled. When an Interrupt is enabled on a "Level", the interrupt is generated as long as the interrupt source is not cleared, even if some read accesses in PIO_ISR are performed.

Figure 29-7. Event Detector on Input Lines (Figure represents line 0)

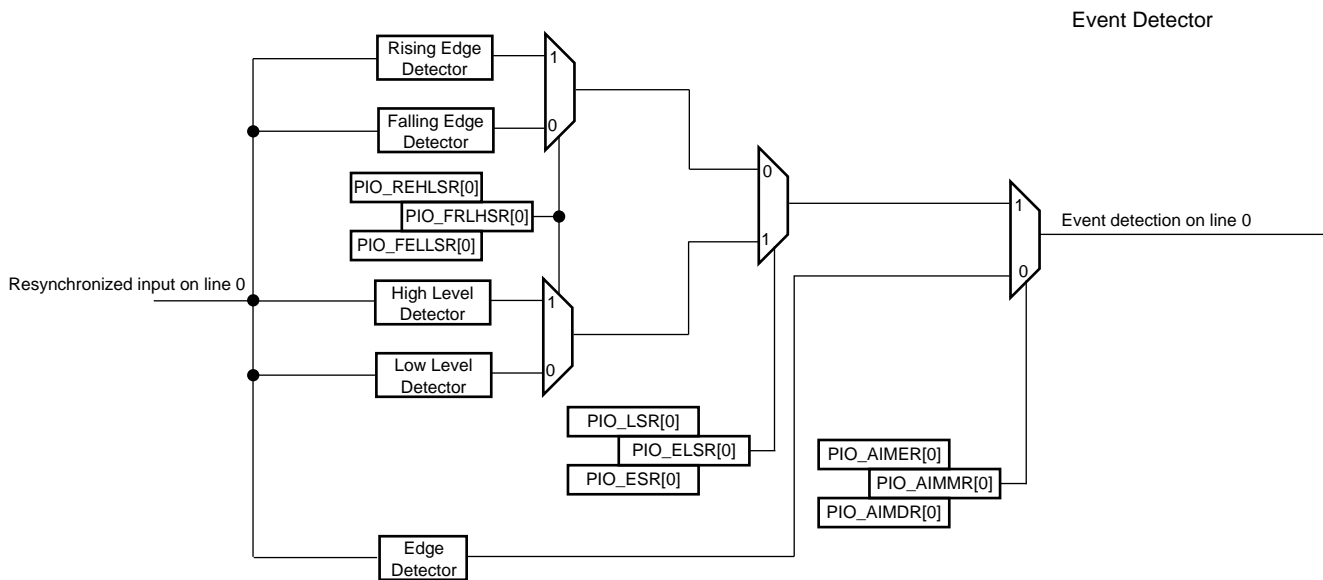

29.5.10.1 Example

If generating an interrupt is required on the following:

- Rising edge on PIO line 0
- Falling edge on PIO line 1
- Rising edge on PIO line 2
- Low Level on PIO line 3
- High Level on PIO line 4
- High Level on PIO line 5
- Falling edge on PIO line 6
- Rising edge on PIO line 7
- Any edge on the other lines

The configuration required is described below.

29.5.10.2 Interrupt Mode Configuration

All the interrupt sources are enabled by writing 32'hFFFF_FFFF in PIO_IER.

Then the Additional Interrupt Mode is enabled for line 0 to 7 by writing 32'h0000_00FF in PIO_AIMER.

29.5.10.3 Edge or Level Detection Configuration

Lines 3, 4 and 5 are configured in Level detection by writing 32'h0000_0038 in PIO_LSR.

The other lines are configured in Edge detection by default, if they have not been previously configured. Otherwise, lines 0, 1, 2, 6 and 7 must be configured in Edge detection by writing 32'h0000_00C7 in PIO_ESR.

29.5.10.4 Falling/Rising Edge or Low/High Level Detection Configuration.

Lines 0, 2, 4, 5 and 7 are configured in Rising Edge or High Level detection by writing 32'h0000_00B5 in PIO_REHLSR.

The other lines are configured in Falling Edge or Low Level detection by default, if they have not been previously configured. Otherwise, lines 1, 3 and 6 must be configured in Falling Edge/Low Level detection by writing 32'h0000_004A in PIO_FELLSR.

Figure 29-8. Input Change Interrupt Timings if there are no Additional Interrupt Modes

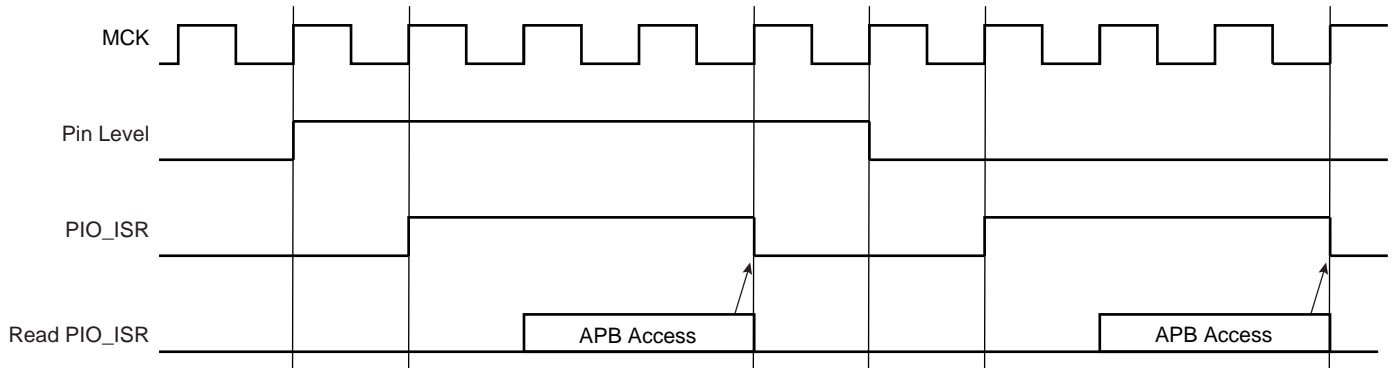

29.5.11 I/O Lines Lock

When an I/O line is controlled by a peripheral (particularly the Pulse Width Modulation Controller PWM), it can become locked by the action of this peripheral via an input of the PIO controller. When an I/O line is locked, the write of the corresponding bit in the registers PIO_PER, PIO_PDR, PIO_MDER, PIO_MDDR, PIO_PUDR, PIO_PUER, PIO_ABCDSR1 and PIO_ABCDSR2 is discarded in order to lock its configuration. The user can know at anytime which I/O line is locked by reading the PIO Lock Status register PIO_LOCKSR. Once an I/O line is locked, the only way to unlock it is to apply a hardware reset to the PIO Controller.

29.5.12 Programmable Schmitt Trigger

It is possible to configure each input for the Schmitt Trigger. By default the Schmitt trigger is active. Disabling the Schmitt Trigger is requested when using the QTouch™ Library.

29.5.13 Parallel Capture Mode

29.5.13.1 Overview

The PIO Controller integrates an interface able to read data from a CMOS digital image sensor, a high-speed parallel ADC, a DSP synchronous port in synchronous mode, etc.... For better understanding and to ease reading, the following description uses an example with a CMOS digital image sensor.

29.5.13.2 Functional Description

The CMOS digital image sensor provides a sensor clock, an 8-bit data synchronous with the sensor clock, and two data enables which are synchronous with the sensor clock too.

Figure 29-9. PIO controller connection with CMOS digital image sensor

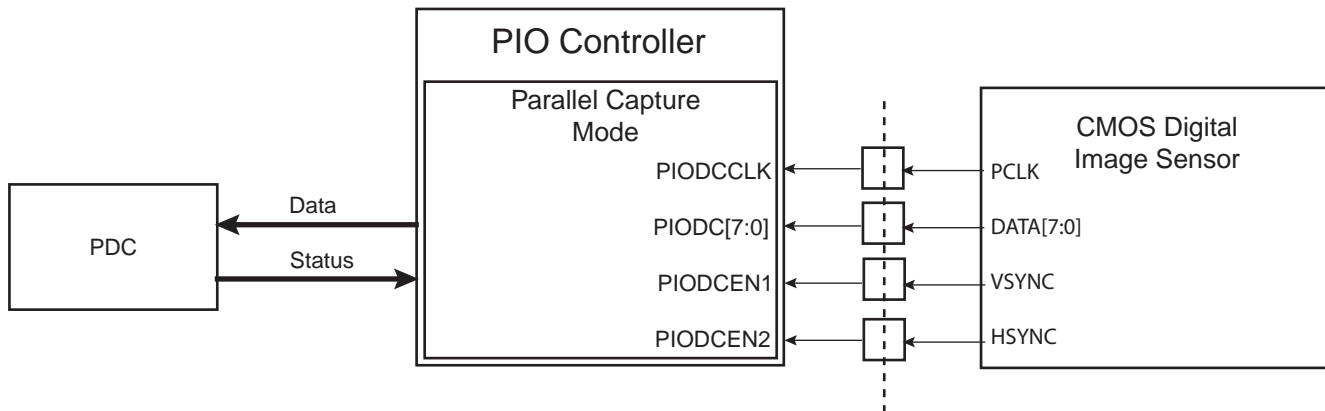

As soon as the parallel capture mode is enabled by writing the PCEN bit at 1 in PIO_PCMR (“PIO Parallel Capture Mode Register”), the I/O lines connected to the sensor clock (PIODCCLK), the sensor data (PIODC[7:0]) and the sensor data enable signals (PIODCEN1 and PIODCEN2) are configured automatically as INPUTS. To know which I/O lines are associated with the sensor clock, the sensor data and the sensor data enable signals, refer to the I/O multiplexing table(s) in the product datasheet.

Once it is enabled, the parallel capture mode samples the data at rising edge of the sensor clock and resynchronizes it with the PIO clock domain.

The size of the data which can be read in PIO_PCRHR (“PIO Parallel Capture Reception Holding Register”) can be programmed thanks to the DSIZE field in PIO_PCMR. If this data size is larger than 8 bits, then the parallel capture mode samples several sensor data to form a concatenated data of size defined by DSIZE. Then this data is stored in PIO_PCRHR and the flag DRDY is set to 1 in PIO_PCISR (“PIO Parallel Capture Interrupt Status Register”).

The parallel capture mode can be associated with a reception channel of the Peripheral DMA Controller (PDC). This enables performing reception transfer from parallel capture mode to a memory buffer without any intervention from the CPU. Transfer status signals from PDC are available in PIO_PCISR through the flags ENDRX and RXBUFF (see “PIO Parallel Capture Interrupt Status Register” on page 587).

The parallel capture mode can take into account the sensor data enable signals or not. If the bit ALWAYS is set to 0 in PIO_PCMR, the parallel capture mode samples the sensor data at the rising edge of the sensor clock only if both data enable signals are active (at 1). If the bit ALWAYS is set to 1, the parallel capture mode samples the sensor data at the rising edge of the sensor clock whichever the data enable signals are.

The parallel capture mode can sample the sensor data only one time out of two. This is particularly useful when the user wants only to sample the luminance Y of a CMOS digital image sensor which outputs a YUV422 data stream. If the HALFS bit is set to 0 in PIO_PCMR, the parallel capture mode samples the sensor data in the conditions described above. If the HALFS bit is set to 1 in PIO_PCMR, the parallel capture mode samples the sensor data in the conditions described above, but only one time out of two. Depending on the FRSTS bit in PIO_PCMR, the sensor can either sample the even or odd sensor data. If sensor data are numbered in the order that they are received with an index from 0 to n, if FRSTS = 0 then only data with an even index are sampled, if FRSTS = 1 then only data with an odd index are sampled. If data is ready in

PIO_PCRHR and it is not read before a new data is stored in PIO_PCRHR, then an overrun error occurs. The previous data is lost and the OVRE flag in PIO_PCISR is set to 1. This flag is automatically reset when PIO_PCISR is read (reset after read).

The flags DRDY, OVRE, ENDRX and RXBUFF can be a source of the PIO interrupt.

Figure 29-10. Parallel Capture Mode Waveforms (DSIZE = 2, ALWAYS = 0, HALFS = 0)

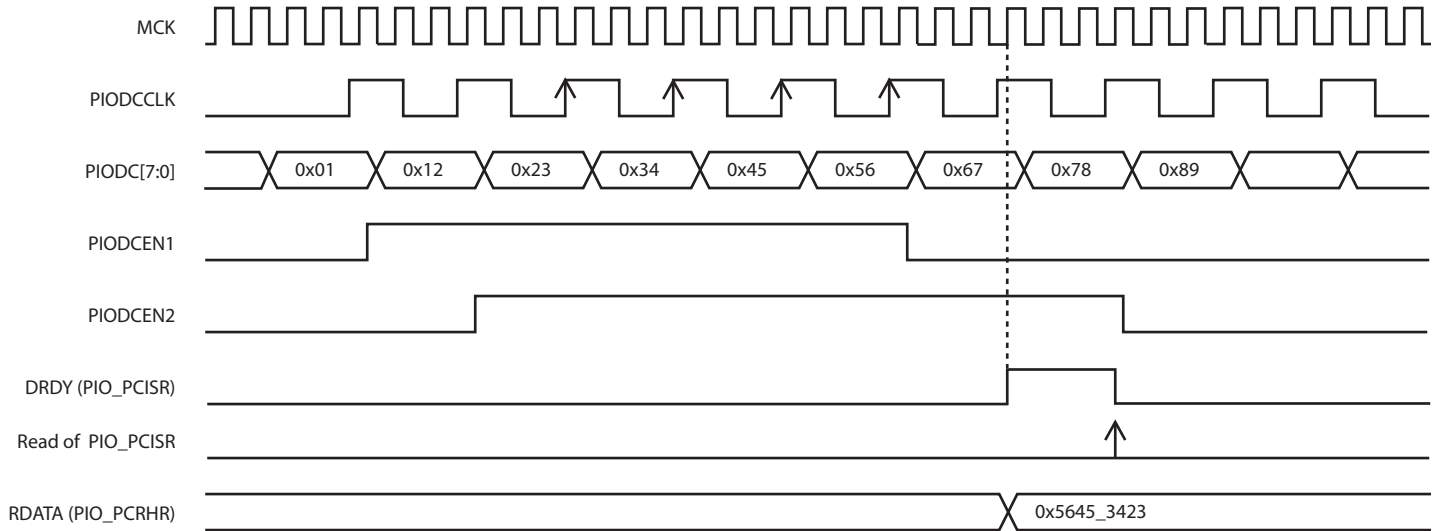

Figure 29-11. Parallel Capture Mode Waveforms (DSIZE=2, ALWAYS=1, HALFS=0)

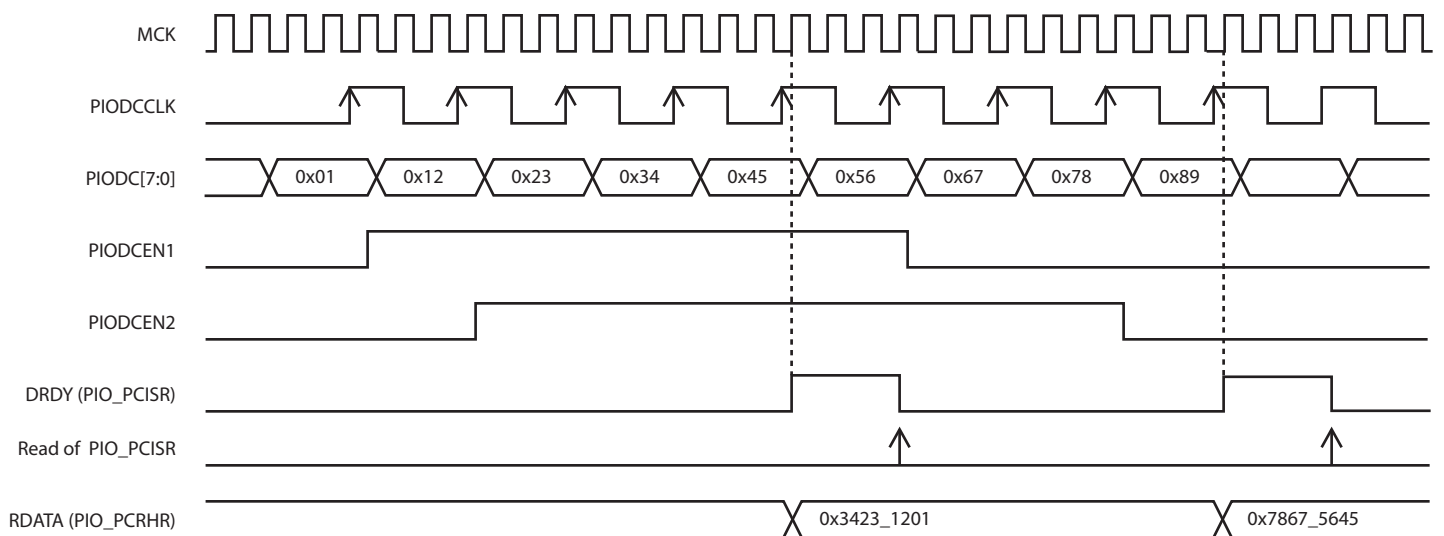

Figure 29-12. Parallel Capture Mode Waveforms (DSIZE=2, ALWAYS=0, HALFS=1, FRSTS=0)

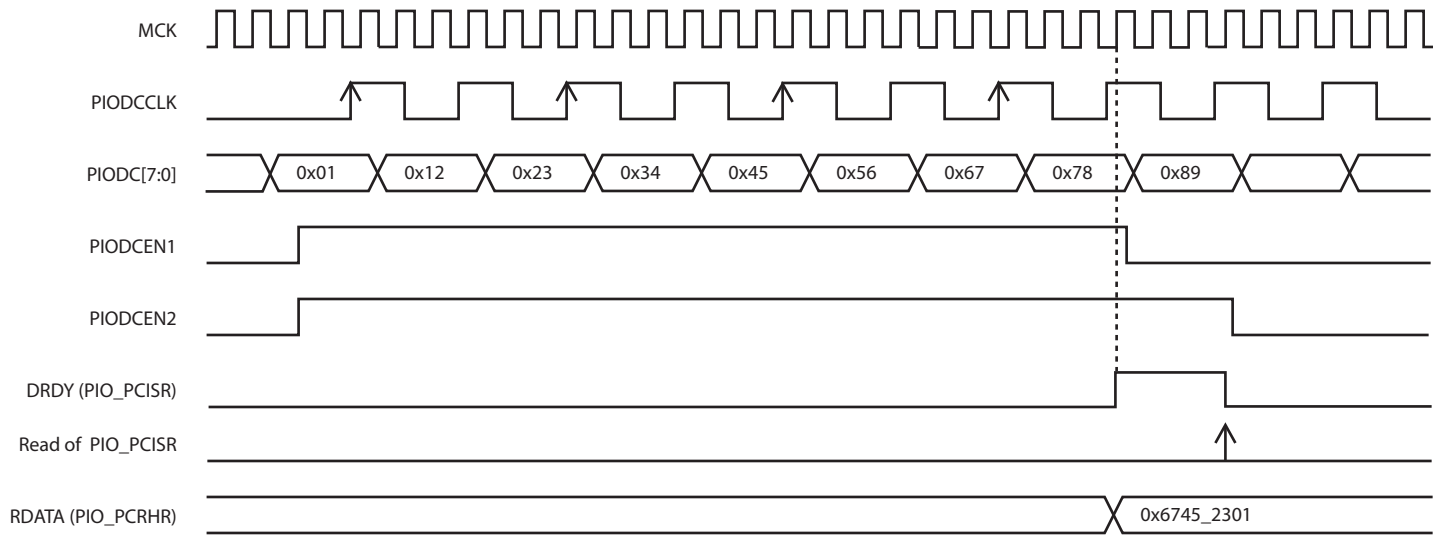
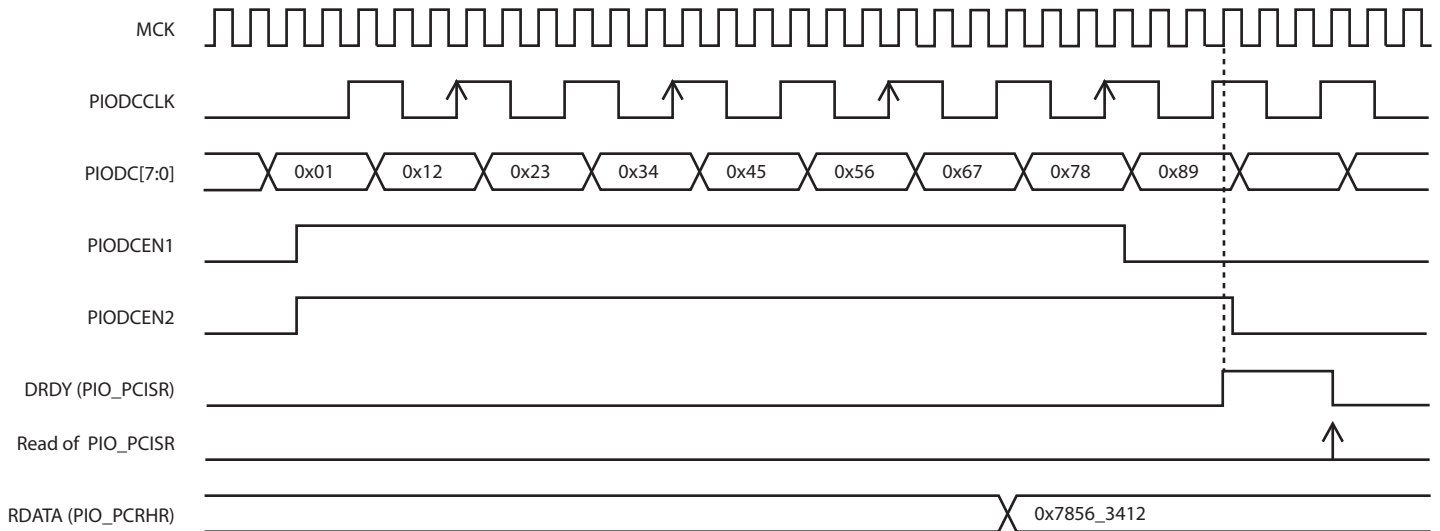

Figure 29-13. Parallel Capture Mode Waveforms (DSIZE=2, ALWAYS=0, HALFS=1, FRSTS=1)



29.5.13.3 Restrictions

- Configuration fields DSIZE, ALWAYS, HALFS and FRSTS in PIO_PCMR (“PIO Parallel Capture Mode Register”) can be changed **ONLY** if the parallel capture mode is disabled at this time (PCEN = 0 in PIO_PCMR).
- Frequency of PIO controller clock must be strictly superior to 2 times the frequency of the clock of the device which generates the parallel data.

29.5.13.4 Programming Sequence

Without PDC

1. Write PIO_PCIDR and PIO_PCIER (“PIO Parallel Capture Interrupt Disable Register” and “PIO Parallel Capture Interrupt Enable Register”) in order to configure the parallel capture mode interrupt mask.
2. Write PIO_PCMR (“PIO Parallel Capture Mode Register”) to set the fields DSIZE, ALWAYS, HALFS and FRSTS in order to configure the parallel capture mode **WITHOUT** enabling the parallel capture mode.
3. Write PIO_PCMR to set the PCEN bit to 1 in order to enable the parallel capture mode **WITHOUT** changing the previous configuration.
4. Wait for a data ready by polling the DRDY flag in PIO_PCISR (“PIO Parallel Capture Interrupt Status Register”) or by waiting the corresponding interrupt.
5. Check OVRE flag in PIO_PCISR.
6. Read the data in PIO_PCRHR (“PIO Parallel Capture Reception Holding Register”).
7. If new data are expected go to step 4.
8. Write PIO_PCMR to set the PCEN bit to 0 in order to disable the parallel capture mode **WITHOUT** changing the previous configuration.

With PDC

1. Write PIO_PCIDR and PIO_PCIER (“PIO Parallel Capture Interrupt Disable Register” and “PIO Parallel Capture Interrupt Enable Register”) in order to configure the parallel capture mode interrupt mask.
2. Configure PDC transfer in PDC registers.
3. Write PIO_PCMR (“PIO Parallel Capture Mode Register”) to set the fields DSIZE, ALWAYS, HALFS and FRSTS in order to configure the parallel capture mode **WITHOUT** enabling the parallel capture mode.
4. Write PIO_PCMR to set PCEN bit to 1 in order to enable the parallel capture mode **WITHOUT** changing the previous configuration.
5. Wait for end of transfer by waiting the interrupt corresponding the flag ENDRX in PIO_PCISR (“PIO Parallel Capture Interrupt Status Register”).
6. Check OVRE flag in PIO_PCISR.
7. If a new buffer transfer is expected go to step 5.
8. Write PIO_PCMR to set the PCEN bit to 0 in order to disable the parallel capture mode **WITHOUT** changing the previous configuration.

29.5.14 Write Protection Registers

To prevent any single software error that may corrupt PIO behavior, certain address spaces can be write-protected by setting the WPEN bit in the “[PIO Write Protect Mode Register](#)” (PIO_WPMR).

If a write access to the protected registers is detected, then the WPVS flag in the PIO Write Protect Status Register (PIO_WPSR) is set and the field WPVSRC indicates in which register the write access has been attempted.

The WPVS flag is reset by writing the PIO Write Protect Mode Register (PIO_WPMR) with the appropriate access key, WPKEY.

The protected registers are:

- “[PIO Enable Register](#)” on page 556
- “[PIO Disable Register](#)” on page 556
- “[PIO Output Enable Register](#)” on page 557
- “[PIO Output Disable Register](#)” on page 558
- “[PIO Input Filter Enable Register](#)” on page 559
- “[PIO Input Filter Disable Register](#)” on page 559
- “[PIO Multi-driver Enable Register](#)” on page 564
- “[PIO Multi-driver Disable Register](#)” on page 565
- “[PIO Pull Up Disable Register](#)” on page 566
- “[PIO Pull Up Enable Register](#)” on page 566
- “[PIO Peripheral ABCD Select Register 1](#)” on page 568
- “[PIO Peripheral ABCD Select Register 2](#)” on page 569
- “[PIO Output Write Enable Register](#)” on page 574
- “[PIO Output Write Disable Register](#)” on page 574
- “[PIO Pad Pull Down Disable Register](#)” on page 572
- “[PIO Pad Pull Down Status Register](#)” on page 573
- “[PIO Parallel Capture Mode Register](#)” on page 584

29.6 I/O Lines Programming Example

The programming example as shown in [Table 29-2](#) below is used to obtain the following configuration.

- 4-bit output port on I/O lines 0 to 3, (should be written in a single write operation), open-drain, with pull-up resistor
- Four output signals on I/O lines 4 to 7 (to drive LEDs for example), driven high and low, no pull-up resistor, no pull-down resistor
- Four input signals on I/O lines 8 to 11 (to read push-button states for example), with pull-up resistors, glitch filters and input change interrupts
- Four input signals on I/O line 12 to 15 to read an external device status (polled, thus no input change interrupt), no pull-up resistor, no glitch filter
- I/O lines 16 to 19 assigned to peripheral A functions with pull-up resistor
- I/O lines 20 to 23 assigned to peripheral B functions with pull-down resistor
- I/O line 24 to 27 assigned to peripheral C with Input Change Interrupt, no pull-up resistor and no pull-down resistor
- I/O line 28 to 31 assigned to peripheral D, no pull-up resistor and no pull-down resistor

Table 29-2. Programming Example

Register	Value to be Written
PIO_PER	0x0000_FFFF
PIO_PDR	0xFFFF_0000
PIO_OER	0x0000_00FF
PIO_ODR	0xFFFF_FF00
PIO_IFER	0x0000_0F00
PIO_IFDR	0xFFFF_F0FF
PIO_SODR	0x0000_0000
PIO_CODR	0x0FFF_FFFF
PIO_IER	0x0F00_0F00
PIO_IDR	0xF0FF_F0FF
PIO_MDER	0x0000_000F
PIO_MDDR	0xFFFF_FFF0
PIO_PUDR	0xFFFF_00F0
PIO_PUER	0x000F_FF0F
PIO_PPDDR	0xFF0F_FFFF
PIO_PPDER	0x00F0_0000
PIO_ABCDSR1	0xF0F0_0000
PIO_ABCDSR2	0xFF00_0000
PIO_OWER	0x0000_000F
PIO_OWDR	0x0FFF_FFF0

29.7 Parallel Input/Output Controller (PIO) User Interface

Each I/O line controlled by the PIO Controller is associated with a bit in each of the PIO Controller User Interface registers. Each register is 32 bits wide. If a parallel I/O line is not defined, writing to the corresponding bits has no effect. Undefined bits read zero. If the I/O line is not multiplexed with any peripheral, the I/O line is controlled by the PIO Controller and PIO_PSR returns 1 systematically.

Table 29-3. Register Mapping

Offset	Register	Name	Access	Reset
0x0000	PIO Enable Register	PIO_PER	Write-only	–
0x0004	PIO Disable Register	PIO_PDR	Write-only	–
0x0008	PIO Status Register	PIO_PSR	Read-only	(1)
0x000C	Reserved			
0x0010	Output Enable Register	PIO_OER	Write-only	–
0x0014	Output Disable Register	PIO_ODR	Write-only	–
0x0018	Output Status Register	PIO_OSR	Read-only	0x0000 0000
0x001C	Reserved			
0x0020	Glitch Input Filter Enable Register	PIO_IFER	Write-only	–
0x0024	Glitch Input Filter Disable Register	PIO_IFDR	Write-only	–
0x0028	Glitch Input Filter Status Register	PIO_IFSR	Read-only	0x0000 0000
0x002C	Reserved			
0x0030	Set Output Data Register	PIO_SODR	Write-only	–
0x0034	Clear Output Data Register	PIO_CODR	Write-only	
0x0038	Output Data Status Register	PIO_ODSR	Read-only or ⁽²⁾ Read-write	–
0x003C	Pin Data Status Register	PIO_PDSR	Read-only	(3)
0x0040	Interrupt Enable Register	PIO_IER	Write-only	–
0x0044	Interrupt Disable Register	PIO_IDR	Write-only	–
0x0048	Interrupt Mask Register	PIO_IMR	Read-only	0x00000000
0x004C	Interrupt Status Register ⁽⁴⁾	PIO_ISR	Read-only	0x00000000
0x0050	Multi-driver Enable Register	PIO_MDER	Write-only	–
0x0054	Multi-driver Disable Register	PIO_MDDR	Write-only	–
0x0058	Multi-driver Status Register	PIO_MDSR	Read-only	0x00000000
0x005C	Reserved			
0x0060	Pull-up Disable Register	PIO_PUDR	Write-only	–
0x0064	Pull-up Enable Register	PIO_PUER	Write-only	–
0x0068	Pad Pull-up Status Register	PIO_PUSR	Read-only	(1)
0x006C	Reserved			

Table 29-3. Register Mapping (Continued)

Offset	Register	Name	Access	Reset
0x0070	Peripheral Select Register 1	PIO_ABCDSR1	Read-write	0x00000000
0x0074	Peripheral Select Register 2	PIO_ABCDSR2	Read-write	0x00000000
0x0078 to 0x007C	Reserved			
0x0080	Input Filter Slow Clock Disable Register	PIO_IFSCDR	Write-only	–
0x0084	Input Filter Slow Clock Enable Register	PIO_IFSCER	Write-only	–
0x0088	Input Filter Slow Clock Status Register	PIO_IFSCSR	Read-only	0x00000000
0x008C	Slow Clock Divider Debouncing Register	PIO_SCDR	Read-write	0x00000000
0x0090	Pad Pull-down Disable Register	PIO_PPDDR	Write-only	–
0x0094	Pad Pull-down Enable Register	PIO_PPDER	Write-only	–
0x0098	Pad Pull-down Status Register	PIO_PPDSR	Read-only	(1)
0x009C	Reserved			
0x00A0	Output Write Enable	PIO_OWER	Write-only	–
0x00A4	Output Write Disable	PIO_OWDR	Write-only	–
0x00A8	Output Write Status Register	PIO_OWSR	Read-only	0x00000000
0x00AC	Reserved			
0x00B0	Additional Interrupt Modes Enable Register	PIO_AIMER	Write-only	–
0x00B4	Additional Interrupt Modes Disables Register	PIO_AIMDR	Write-only	–
0x00B8	Additional Interrupt Modes Mask Register	PIO_AIMMR	Read-only	0x00000000
0x00BC	Reserved			
0x00C0	Edge Select Register	PIO_ESR	Write-only	–
0x00C4	Level Select Register	PIO_LSR	Write-only	–
0x00C8	Edge/Level Status Register	PIO_ELSR	Read-only	0x00000000
0x00CC	Reserved			
0x00D0	Falling Edge/Low Level Select Register	PIO_FELLSR	Write-only	–
0x00D4	Rising Edge/ High Level Select Register	PIO_REHLSR	Write-only	–
0x00D8	Fall/Rise - Low/High Status Register	PIO_FRLHSR	Read-only	0x00000000
0x00DC	Reserved			
0x00E0	Lock Status	PIO_LOCKSR	Read-only	0x00000000
0x00E4	Write Protect Mode Register	PIO_WPMR	Read-write	0x0
0x00E8	Write Protect Status Register	PIO_WPSR	Read-only	0x0
0x00EC to 0x00F8	Reserved			
0x0100	Schmitt Trigger Register	PIO_SCHMITT	Read-write	0x00000000
0x0104- 0x010C	Reserved			

Table 29-3. Register Mapping (Continued)

Offset	Register	Name	Access	Reset
0x0110	Reserved			
0x0114-0x011C	Reserved			
0x150	Parallel Capture Mode Register	PIO_PCMR	Read-write	0x00000000
0x154	Parallel Capture Interrupt Enable Register	PIO_PCIER	Write-only	–
0x158	Parallel Capture Interrupt Disable Register	PIO_PCIDR	Write-only	–
0x15C	Parallel Capture Interrupt Mask Register	PIO_PCIMR	Read-only	0x00000000
0x160	Parallel Capture Interrupt Status Register	PIO_PCISR	Read-only	0x00000000
0x164	Parallel Capture Reception Holding Register	PIO_PCRHR	Read-only	0x00000000
0x0168 to 0x018C	Reserved for PDC Registers			

- Notes:
1. Reset value depends on the product implementation.
 2. PIO_ODSR is Read-only or Read/Write depending on PIO_OWSR I/O lines.
 3. Reset value of PIO_PDSR depends on the level of the I/O lines. Reading the I/O line levels requires the clock of the PIO Controller to be enabled, otherwise PIO_PDSR reads the levels present on the I/O line at the time the clock was disabled.
 4. PIO_ISR is reset at 0x0. However, the first read of the register may read a different value as input changes may have occurred.

Note: if an offset is not listed in the table it must be considered as reserved.

29.7.1 PIO Enable Register

Name: PIO_PER

Address: 0x400E0E00 (PIOA), 0x400E1000 (PIOB), 0x400E1200 (PIOC)

Access: Write-only

31	30	29	28	27	26	25	24
P31	P30	P29	P28	P27	P26	P25	P24
23	22	21	20	19	18	17	16
P23	P22	P21	P20	P19	P18	P17	P16
15	14	13	12	11	10	9	8
P15	P14	P13	P12	P11	P10	P9	P8
7	6	5	4	3	2	1	0
P7	P6	P5	P4	P3	P2	P1	P0

This register can only be written if the WPEN bit is cleared in [“PIO Write Protect Mode Register”](#) .

- **P0-P31: PIO Enable**

0 = No effect.

1 = Enables the PIO to control the corresponding pin (disables peripheral control of the pin).

29.7.2 PIO Disable Register

Name: PIO_PDR

Address: 0x400E0E04 (PIOA), 0x400E1004 (PIOB), 0x400E1204 (PIOC)

Access: Write-only

31	30	29	28	27	26	25	24
P31	P30	P29	P28	P27	P26	P25	P24
23	22	21	20	19	18	17	16
P23	P22	P21	P20	P19	P18	P17	P16
15	14	13	12	11	10	9	8
P15	P14	P13	P12	P11	P10	P9	P8
7	6	5	4	3	2	1	0
P7	P6	P5	P4	P3	P2	P1	P0

This register can only be written if the WPEN bit is cleared in [“PIO Write Protect Mode Register”](#) .

- **P0-P31: PIO Disable**

0 = No effect.

1 = Disables the PIO from controlling the corresponding pin (enables peripheral control of the pin).

29.7.3 PIO Status Register

Name: PIO_PSR

Address: 0x400E0E08 (PIOA), 0x400E1008 (PIOB), 0x400E1208 (PIOC)

Access: Read-only

31	30	29	28	27	26	25	24
P31	P30	P29	P28	P27	P26	P25	P24
23	22	21	20	19	18	17	16
P23	P22	P21	P20	P19	P18	P17	P16
15	14	13	12	11	10	9	8
P15	P14	P13	P12	P11	P10	P9	P8
7	6	5	4	3	2	1	0
P7	P6	P5	P4	P3	P2	P1	P0

- P0-P31: PIO Status**

0 = PIO is inactive on the corresponding I/O line (peripheral is active).

1 = PIO is active on the corresponding I/O line (peripheral is inactive).

29.7.4 PIO Output Enable Register

Name: PIO_OER

Address: 0x400E0E10 (PIOA), 0x400E1010 (PIOB), 0x400E1210 (PIOC)

Access: Write-only

31	30	29	28	27	26	25	24
P31	P30	P29	P28	P27	P26	P25	P24
23	22	21	20	19	18	17	16
P23	P22	P21	P20	P19	P18	P17	P16
15	14	13	12	11	10	9	8
P15	P14	P13	P12	P11	P10	P9	P8
7	6	5	4	3	2	1	0
P7	P6	P5	P4	P3	P2	P1	P0

This register can only be written if the WPEN bit is cleared in [“PIO Write Protect Mode Register”](#).

- P0-P31: Output Enable**

0 = No effect.

1 = Enables the output on the I/O line.



29.7.5 PIO Output Disable Register

Name: PIO_ODR

Address: 0x400E0E14 (PIOA), 0x400E1014 (PIOB), 0x400E1214 (PIOC)

Access: Write-only

31	30	29	28	27	26	25	24
P31	P30	P29	P28	P27	P26	P25	P24
23	22	21	20	19	18	17	16
P23	P22	P21	P20	P19	P18	P17	P16
15	14	13	12	11	10	9	8
P15	P14	P13	P12	P11	P10	P9	P8
7	6	5	4	3	2	1	0
P7	P6	P5	P4	P3	P2	P1	P0

This register can only be written if the WPEN bit is cleared in "PIO Write Protect Mode Register" .

• **P0-P31: Output Disable**

0 = No effect.

1 = Disables the output on the I/O line.

29.7.6 PIO Output Status Register

Name: PIO_OSR

Address: 0x400E0E18 (PIOA), 0x400E1018 (PIOB), 0x400E1218 (PIOC)

Access: Read-only

31	30	29	28	27	26	25	24
P31	P30	P29	P28	P27	P26	P25	P24
23	22	21	20	19	18	17	16
P23	P22	P21	P20	P19	P18	P17	P16
15	14	13	12	11	10	9	8
P15	P14	P13	P12	P11	P10	P9	P8
7	6	5	4	3	2	1	0
P7	P6	P5	P4	P3	P2	P1	P0

• **P0-P31: Output Status**

0 = The I/O line is a pure input.

1 = The I/O line is enabled in output.

29.7.7 PIO Input Filter Enable Register

Name: PIO_IFER

Address: 0x400E0E20 (PIOA), 0x400E1020 (PIOB), 0x400E1220 (PIOC)

Access: Write-only

31	30	29	28	27	26	25	24
P31	P30	P29	P28	P27	P26	P25	P24
23	22	21	20	19	18	17	16
P23	P22	P21	P20	P19	P18	P17	P16
15	14	13	12	11	10	9	8
P15	P14	P13	P12	P11	P10	P9	P8
7	6	5	4	3	2	1	0
P7	P6	P5	P4	P3	P2	P1	P0

This register can only be written if the WPEN bit is cleared in ["PIO Write Protect Mode Register"](#) .

- **P0-P31: Input Filter Enable**

0 = No effect.

1 = Enables the input glitch filter on the I/O line.

29.7.8 PIO Input Filter Disable Register

Name: PIO_IFDR

Address: 0x400E0E24 (PIOA), 0x400E1024 (PIOB), 0x400E1224 (PIOC)

Access: Write-only

31	30	29	28	27	26	25	24
P31	P30	P29	P28	P27	P26	P25	P24
23	22	21	20	19	18	17	16
P23	P22	P21	P20	P19	P18	P17	P16
15	14	13	12	11	10	9	8
P15	P14	P13	P12	P11	P10	P9	P8
7	6	5	4	3	2	1	0
P7	P6	P5	P4	P3	P2	P1	P0

This register can only be written if the WPEN bit is cleared in ["PIO Write Protect Mode Register"](#) .

- **P0-P31: Input Filter Disable**

0 = No effect.

1 = Disables the input glitch filter on the I/O line.



29.7.9 PIO Input Filter Status Register

Name: PIO_IFSR

Address: 0x400E0E28 (PIOA), 0x400E1028 (PIOB), 0x400E1228 (PIOC)

Access: Read-only

31	30	29	28	27	26	25	24
P31	P30	P29	P28	P27	P26	P25	P24
23	22	21	20	19	18	17	16
P23	P22	P21	P20	P19	P18	P17	P16
15	14	13	12	11	10	9	8
P15	P14	P13	P12	P11	P10	P9	P8
7	6	5	4	3	2	1	0
P7	P6	P5	P4	P3	P2	P1	P0

- **P0-P31: Input Filter Status**

0 = The input glitch filter is disabled on the I/O line.

1 = The input glitch filter is enabled on the I/O line.

29.7.10 PIO Set Output Data Register

Name: PIO_SODR

Address: 0x400E0E30 (PIOA), 0x400E1030 (PIOB), 0x400E1230 (PIOC)

Access: Write-only

31	30	29	28	27	26	25	24
P31	P30	P29	P28	P27	P26	P25	P24
23	22	21	20	19	18	17	16
P23	P22	P21	P20	P19	P18	P17	P16
15	14	13	12	11	10	9	8
P15	P14	P13	P12	P11	P10	P9	P8
7	6	5	4	3	2	1	0
P7	P6	P5	P4	P3	P2	P1	P0

- **P0-P31: Set Output Data**

0 = No effect.

1 = Sets the data to be driven on the I/O line.

29.7.11 PIO Clear Output Data Register

Name: PIO_CODR

Address: 0x400E0E34 (PIOA), 0x400E1034 (PIOB), 0x400E1234 (PIOC)

Access: Write-only

31	30	29	28	27	26	25	24
P31	P30	P29	P28	P27	P26	P25	P24
23	22	21	20	19	18	17	16
P23	P22	P21	P20	P19	P18	P17	P16
15	14	13	12	11	10	9	8
P15	P14	P13	P12	P11	P10	P9	P8
7	6	5	4	3	2	1	0
P7	P6	P5	P4	P3	P2	P1	P0

- **P0-P31: Clear Output Data**

0 = No effect.

1 = Clears the data to be driven on the I/O line.

29.7.12 PIO Output Data Status Register

Name: PIO_ODSR

Address: 0x400E0E38 (PIOA), 0x400E1038 (PIOB), 0x400E1238 (PIOC)

Access: Read-only or Read-write

31	30	29	28	27	26	25	24
P31	P30	P29	P28	P27	P26	P25	P24
23	22	21	20	19	18	17	16
P23	P22	P21	P20	P19	P18	P17	P16
15	14	13	12	11	10	9	8
P15	P14	P13	P12	P11	P10	P9	P8
7	6	5	4	3	2	1	0
P7	P6	P5	P4	P3	P2	P1	P0

- **P0-P31: Output Data Status**

0 = The data to be driven on the I/O line is 0.

1 = The data to be driven on the I/O line is 1.



29.7.13 PIO Pin Data Status Register

Name: PIO_PDSR

Address: 0x400E0E3C (PIOA), 0x400E103C (PIOB), 0x400E123C (PIOC)

Access: Read-only

31	30	29	28	27	26	25	24
P31	P30	P29	P28	P27	P26	P25	P24
23	22	21	20	19	18	17	16
P23	P22	P21	P20	P19	P18	P17	P16
15	14	13	12	11	10	9	8
P15	P14	P13	P12	P11	P10	P9	P8
7	6	5	4	3	2	1	0
P7	P6	P5	P4	P3	P2	P1	P0

• **P0-P31: Output Data Status**

0 = The I/O line is at level 0.

1 = The I/O line is at level 1.

29.7.14 PIO Interrupt Enable Register

Name: PIO_IER

Address: 0x400E0E40 (PIOA), 0x400E1040 (PIOB), 0x400E1240 (PIOC)

Access: Write-only

31	30	29	28	27	26	25	24
P31	P30	P29	P28	P27	P26	P25	P24
23	22	21	20	19	18	17	16
P23	P22	P21	P20	P19	P18	P17	P16
15	14	13	12	11	10	9	8
P15	P14	P13	P12	P11	P10	P9	P8
7	6	5	4	3	2	1	0
P7	P6	P5	P4	P3	P2	P1	P0

• **P0-P31: Input Change Interrupt Enable**

0 = No effect.

1 = Enables the Input Change Interrupt on the I/O line.

29.7.15 PIO Interrupt Disable Register

Name: PIO_IDR

Address: 0x400E0E44 (PIOA), 0x400E1044 (PIOB), 0x400E1244 (PIOC)

Access: Write-only

31	30	29	28	27	26	25	24
P31	P30	P29	P28	P27	P26	P25	P24
23	22	21	20	19	18	17	16
P23	P22	P21	P20	P19	P18	P17	P16
15	14	13	12	11	10	9	8
P15	P14	P13	P12	P11	P10	P9	P8
7	6	5	4	3	2	1	0
P7	P6	P5	P4	P3	P2	P1	P0

- **P0-P31: Input Change Interrupt Disable**

0 = No effect.

1 = Disables the Input Change Interrupt on the I/O line.

29.7.16 PIO Interrupt Mask Register

Name: PIO_IMR

Address: 0x400E0E48 (PIOA), 0x400E1048 (PIOB), 0x400E1248 (PIOC)

Access: Read-only

31	30	29	28	27	26	25	24
P31	P30	P29	P28	P27	P26	P25	P24
23	22	21	20	19	18	17	16
P23	P22	P21	P20	P19	P18	P17	P16
15	14	13	12	11	10	9	8
P15	P14	P13	P12	P11	P10	P9	P8
7	6	5	4	3	2	1	0
P7	P6	P5	P4	P3	P2	P1	P0

- **P0-P31: Input Change Interrupt Mask**

0 = Input Change Interrupt is disabled on the I/O line.

1 = Input Change Interrupt is enabled on the I/O line.



29.7.17 PIO Interrupt Status Register

Name: PIO_ISR

Address: 0x400E0E4C (PIOA), 0x400E104C (PIOB), 0x400E124C (PIOC)

Access: Read-only

31	30	29	28	27	26	25	24
P31	P30	P29	P28	P27	P26	P25	P24
23	22	21	20	19	18	17	16
P23	P22	P21	P20	P19	P18	P17	P16
15	14	13	12	11	10	9	8
P15	P14	P13	P12	P11	P10	P9	P8
7	6	5	4	3	2	1	0
P7	P6	P5	P4	P3	P2	P1	P0

• **P0-P31: Input Change Interrupt Status**

0 = No Input Change has been detected on the I/O line since PIO_ISR was last read or since reset.

1 = At least one Input Change has been detected on the I/O line since PIO_ISR was last read or since reset.

29.7.18 PIO Multi-driver Enable Register

Name: PIO_MDER

Address: 0x400E0E50 (PIOA), 0x400E1050 (PIOB), 0x400E1250 (PIOC)

Access: Write-only

31	30	29	28	27	26	25	24
P31	P30	P29	P28	P27	P26	P25	P24
23	22	21	20	19	18	17	16
P23	P22	P21	P20	P19	P18	P17	P16
15	14	13	12	11	10	9	8
P15	P14	P13	P12	P11	P10	P9	P8
7	6	5	4	3	2	1	0
P7	P6	P5	P4	P3	P2	P1	P0

This register can only be written if the WPEN bit is cleared in ["PIO Write Protect Mode Register"](#) .

• **P0-P31: Multi Drive Enable.**

0 = No effect.

1 = Enables Multi Drive on the I/O line.

29.7.19 PIO Multi-driver Disable Register

Name: PIO_MDDR

Address: 0x400E0E54 (PIOA), 0x400E1054 (PIOB), 0x400E1254 (PIOC)

Access: Write-only

31	30	29	28	27	26	25	24
P31	P30	P29	P28	P27	P26	P25	P24
23	22	21	20	19	18	17	16
P23	P22	P21	P20	P19	P18	P17	P16
15	14	13	12	11	10	9	8
P15	P14	P13	P12	P11	P10	P9	P8
7	6	5	4	3	2	1	0
P7	P6	P5	P4	P3	P2	P1	P0

This register can only be written if the WPEN bit is cleared in [“PIO Write Protect Mode Register”](#) .

- **P0-P31: Multi Drive Disable.**

0 = No effect.

1 = Disables Multi Drive on the I/O line.

29.7.20 PIO Multi-driver Status Register

Name: PIO_MDSR

Address: 0x400E0E58 (PIOA), 0x400E1058 (PIOB), 0x400E1258 (PIOC)

Access: Read-only

31	30	29	28	27	26	25	24
P31	P30	P29	P28	P27	P26	P25	P24
23	22	21	20	19	18	17	16
P23	P22	P21	P20	P19	P18	P17	P16
15	14	13	12	11	10	9	8
P15	P14	P13	P12	P11	P10	P9	P8
7	6	5	4	3	2	1	0
P7	P6	P5	P4	P3	P2	P1	P0

- **P0-P31: Multi Drive Status.**

0 = The Multi Drive is disabled on the I/O line. The pin is driven at high and low level.

1 = The Multi Drive is enabled on the I/O line. The pin is driven at low level only.

29.7.21 PIO Pull Up Disable Register

Name: PIO_PUDR

Address: 0x400E0E60 (PIOA), 0x400E1060 (PIOB), 0x400E1260 (PIOC)

Access: Write-only

31	30	29	28	27	26	25	24
P31	P30	P29	P28	P27	P26	P25	P24
23	22	21	20	19	18	17	16
P23	P22	P21	P20	P19	P18	P17	P16
15	14	13	12	11	10	9	8
P15	P14	P13	P12	P11	P10	P9	P8
7	6	5	4	3	2	1	0
P7	P6	P5	P4	P3	P2	P1	P0

This register can only be written if the WPEN bit is cleared in [“PIO Write Protect Mode Register”](#) .

- **P0-P31: Pull Up Disable.**

0 = No effect.

1 = Disables the pull up resistor on the I/O line.

29.7.22 PIO Pull Up Enable Register

Name: PIO_PUER

Address: 0x400E0E64 (PIOA), 0x400E1064 (PIOB), 0x400E1264 (PIOC)

Access: Write-only

31	30	29	28	27	26	25	24
P31	P30	P29	P28	P27	P26	P25	P24
23	22	21	20	19	18	17	16
P23	P22	P21	P20	P19	P18	P17	P16
15	14	13	12	11	10	9	8
P15	P14	P13	P12	P11	P10	P9	P8
7	6	5	4	3	2	1	0
P7	P6	P5	P4	P3	P2	P1	P0

This register can only be written if the WPEN bit is cleared in [“PIO Write Protect Mode Register”](#) .

- **P0-P31: Pull Up Enable.**

0 = No effect.

1 = Enables the pull up resistor on the I/O line.

29.7.23 PIO Pull Up Status Register

Name: PIO_PUSR

Address: 0x400E0E68 (PIOA), 0x400E1068 (PIOB), 0x400E1268 (PIOC)

Access: Read-only

31	30	29	28	27	26	25	24
P31	P30	P29	P28	P27	P26	P25	P24
23	22	21	20	19	18	17	16
P23	P22	P21	P20	P19	P18	P17	P16
15	14	13	12	11	10	9	8
P15	P14	P13	P12	P11	P10	P9	P8
7	6	5	4	3	2	1	0
P7	P6	P5	P4	P3	P2	P1	P0

- **P0-P31: Pull Up Status.**

0 = Pull Up resistor is enabled on the I/O line.

1 = Pull Up resistor is disabled on the I/O line.

29.7.24 PIO Peripheral ABCD Select Register 1

Name: PIO_ABCDSR1

Access: Read-write

31	30	29	28	27	26	25	24
P31	P30	P29	P28	P27	P26	P25	P24
23	22	21	20	19	18	17	16
P23	P22	P21	P20	P19	P18	P17	P16
15	14	13	12	11	10	9	8
P15	P14	P13	P12	P11	P10	P9	P8
7	6	5	4	3	2	1	0
P7	P6	P5	P4	P3	P2	P1	P0

This register can only be written if the WPEN bit is cleared in ["PIO Write Protect Mode Register"](#) .

- **P0-P31: Peripheral Select.**

If the same bit is set to 0 in PIO_ABCDSR2:

0 = Assigns the I/O line to the Peripheral A function.

1 = Assigns the I/O line to the Peripheral B function.

If the same bit is set to 1 in PIO_ABCDSR2:

0 = Assigns the I/O line to the Peripheral C function.

1 = Assigns the I/O line to the Peripheral D function.

29.7.25 PIO Peripheral ABCD Select Register 2

Name: PIO_ABCDSR2

Access: Read-write

31	30	29	28	27	26	25	24
P31	P30	P29	P28	P27	P26	P25	P24
23	22	21	20	19	18	17	16
P23	P22	P21	P20	P19	P18	P17	P16
15	14	13	12	11	10	9	8
P15	P14	P13	P12	P11	P10	P9	P8
7	6	5	4	3	2	1	0
P7	P6	P5	P4	P3	P2	P1	P0

This register can only be written if the WPEN bit is cleared in ["PIO Write Protect Mode Register"](#) .

- **P0-P31: Peripheral Select.**

If the same bit is set to 0 in PIO_ABCDSR1:

0 = Assigns the I/O line to the Peripheral A function.

1 = Assigns the I/O line to the Peripheral C function.

If the same bit is set to 1 in PIO_ABCDSR1:

0 = Assigns the I/O line to the Peripheral B function.

1 = Assigns the I/O line to the Peripheral D function.

29.7.26 PIO Input Filter Slow Clock Disable Register

Name: PIO_IFSCDR

Address: 0x400E0E80 (PIOA), 0x400E1080 (PIOB), 0x400E1280 (PIOC)

Access: Write-only

31	30	29	28	27	26	25	24
P31	P30	P29	P28	P27	P26	P25	P24
23	22	21	20	19	18	17	16
P23	P22	P21	P20	P19	P18	P17	P16
15	14	13	12	11	10	9	8
P15	P14	P13	P12	P11	P10	P9	P8
7	6	5	4	3	2	1	0
P7	P6	P5	P4	P3	P2	P1	P0

- **P0-P31: PIO Clock Glitch Filtering Select.**

0 = No Effect.

1 = The Glitch Filter is able to filter glitches with a duration $< T_{mck}/2$.

29.7.27 PIO Input Filter Slow Clock Enable Register

Name: PIO_IFSCER

Address: 0x400E0E84 (PIOA), 0x400E1084 (PIOB), 0x400E1284 (PIOC)

Access: Write-only

31	30	29	28	27	26	25	24
P31	P30	P29	P28	P27	P26	P25	P24
23	22	21	20	19	18	17	16
P23	P22	P21	P20	P19	P18	P17	P16
15	14	13	12	11	10	9	8
P15	P14	P13	P12	P11	P10	P9	P8
7	6	5	4	3	2	1	0
P7	P6	P5	P4	P3	P2	P1	P0

- **P0-P31: Debouncing Filtering Select.**

0 = No Effect.

1 = The Debouncing Filter is able to filter pulses with a duration $< T_{div_slck}/2$.

29.7.28 PIO Input Filter Slow Clock Status Register

Name: PIO_IFSCSR

Address: 0x400E0E88 (PIOA), 0x400E1088 (PIOB), 0x400E1288 (PIOC)

Access: Read-only

31	30	29	28	27	26	25	24
P31	P30	P29	P28	P27	P26	P25	P24
23	22	21	20	19	18	17	16
P23	P22	P21	P20	P19	P18	P17	P16
15	14	13	12	11	10	9	8
P15	P14	P13	P12	P11	P10	P9	P8
7	6	5	4	3	2	1	0
P7	P6	P5	P4	P3	P2	P1	P0

- P0-P31: Glitch or Debouncing Filter Selection Status**

0 = The Glitch Filter is able to filter glitches with a duration < Tmck2.

1 = The Debouncing Filter is able to filter pulses with a duration < Tdiv_slclk/2.

29.7.29 PIO Slow Clock Divider Debouncing Register

Name: PIO_SCDR

Address: 0x400E0E8C (PIOA), 0x400E108C (PIOB), 0x400E128C (PIOC)

Access: Read-write

31	30	29	28	27	26	25	24
–	–	–	–	–	–	–	–
23	22	21	20	19	18	17	16
–	–	–	–	–	–	–	–
15	14	13	12	11	10	9	8
–	–	DIV					
7	6	5	4	3	2	1	0
DIV							

- DIVx: Slow Clock Divider Selection for Debouncing**

$T_{div_slclk} = 2 * (DIV + 1) * T_{slow_clock}$.



29.7.30 PIO Pad Pull Down Disable Register

Name: PIO_PPDDR

Address: 0x400E0E90 (PIOA), 0x400E1090 (PIOB), 0x400E1290 (PIOC)

Access: Write-only

31	30	29	28	27	26	25	24
P31	P30	P29	P28	P27	P26	P25	P24
23	22	21	20	19	18	17	16
P23	P22	P21	P20	P19	P18	P17	P16
15	14	13	12	11	10	9	8
P15	P14	P13	P12	P11	P10	P9	P8
7	6	5	4	3	2	1	0
P7	P6	P5	P4	P3	P2	P1	P0

This register can only be written if the WPEN bit is cleared in ["PIO Write Protect Mode Register"](#) .

• **P0-P31: Pull Down Disable.**

0 = No effect.

1 = Disables the pull down resistor on the I/O line.

29.7.31 PIO Pad Pull Down Enable Register

Name: PIO_PPDER

Address: 0x400E0E94 (PIOA), 0x400E1094 (PIOB), 0x400E1294 (PIOC)

Access: Write-only

31	30	29	28	27	26	25	24
P31	P30	P29	P28	P27	P26	P25	P24
23	22	21	20	19	18	17	16
P23	P22	P21	P20	P19	P18	P17	P16
15	14	13	12	11	10	9	8
P15	P14	P13	P12	P11	P10	P9	P8
7	6	5	4	3	2	1	0
P7	P6	P5	P4	P3	P2	P1	P0

This register can only be written if the WPEN bit is cleared in ["PIO Write Protect Mode Register"](#) .

• **P0-P31: Pull Down Enable.**

0 = No effect.

1 = Enables the pull down resistor on the I/O line.

29.7.32 PIO Pad Pull Down Status Register

Name: PIO_PPDSR

Address: 0x400E0E98 (PIOA), 0x400E1098 (PIOB), 0x400E1298 (PIOC)

Access: Read-only

31	30	29	28	27	26	25	24
P31	P30	P29	P28	P27	P26	P25	P24
23	22	21	20	19	18	17	16
P23	P22	P21	P20	P19	P18	P17	P16
15	14	13	12	11	10	9	8
P15	P14	P13	P12	P11	P10	P9	P8
7	6	5	4	3	2	1	0
P7	P6	P5	P4	P3	P2	P1	P0

This register can only be written if the WPEN bit is cleared in ["PIO Write Protect Mode Register"](#) .

- **P0-P31: Pull Down Status.**

0 = Pull Down resistor is enabled on the I/O line.

1 = Pull Down resistor is disabled on the I/O line.



29.7.33 PIO Output Write Enable Register

Name: PIO_OWER

Address: 0x400E0EA0 (PIOA), 0x400E10A0 (PIOB), 0x400E12A0 (PIOC)

Access: Write-only

31	30	29	28	27	26	25	24
P31	P30	P29	P28	P27	P26	P25	P24
23	22	21	20	19	18	17	16
P23	P22	P21	P20	P19	P18	P17	P16
15	14	13	12	11	10	9	8
P15	P14	P13	P12	P11	P10	P9	P8
7	6	5	4	3	2	1	0
P7	P6	P5	P4	P3	P2	P1	P0

This register can only be written if the WPEN bit is cleared in ["PIO Write Protect Mode Register"](#) .

• **P0-P31: Output Write Enable.**

0 = No effect.

1 = Enables writing PIO_ODSR for the I/O line.

29.7.34 PIO Output Write Disable Register

Name: PIO_OWDR

Address: 0x400E0EA4 (PIOA), 0x400E10A4 (PIOB), 0x400E12A4 (PIOC)

Access: Write-only

31	30	29	28	27	26	25	24
P31	P30	P29	P28	P27	P26	P25	P24
23	22	21	20	19	18	17	16
P23	P22	P21	P20	P19	P18	P17	P16
15	14	13	12	11	10	9	8
P15	P14	P13	P12	P11	P10	P9	P8
7	6	5	4	3	2	1	0
P7	P6	P5	P4	P3	P2	P1	P0

This register can only be written if the WPEN bit is cleared in ["PIO Write Protect Mode Register"](#) .

• **P0-P31: Output Write Disable.**

0 = No effect.

1 = Disables writing PIO_ODSR for the I/O line.

29.7.35 PIO Output Write Status Register

Name: PIO_OWSR

Address: 0x400E0EA8 (PIOA), 0x400E10A8 (PIOB), 0x400E12A8 (PIOC)

Access: Read-only

31	30	29	28	27	26	25	24
P31	P30	P29	P28	P27	P26	P25	P24
23	22	21	20	19	18	17	16
P23	P22	P21	P20	P19	P18	P17	P16
15	14	13	12	11	10	9	8
P15	P14	P13	P12	P11	P10	P9	P8
7	6	5	4	3	2	1	0
P7	P6	P5	P4	P3	P2	P1	P0

- **P0-P31: Output Write Status.**

0 = Writing PIO_ODSR does not affect the I/O line.

1 = Writing PIO_ODSR affects the I/O line.

29.7.36 PIO Additional Interrupt Modes Enable Register

Name: PIO_AIMER

Address: 0x400E0EB0 (PIOA), 0x400E10B0 (PIOB), 0x400E12B0 (PIOC)

Access: Write-only

31	30	29	28	27	26	25	24
P31	P30	P29	P28	P27	P26	P25	P24
23	22	21	20	19	18	17	16
P23	P22	P21	P20	P19	P18	P17	P16
15	14	13	12	11	10	9	8
P15	P14	P13	P12	P11	P10	P9	P8
7	6	5	4	3	2	1	0
P7	P6	P5	P4	P3	P2	P1	P0

- **P0-P31: Additional Interrupt Modes Enable.**

0 = No effect.

1 = The interrupt source is the event described in PIO_ELSR and PIO_FRLHSR.

29.7.37 PIO Additional Interrupt Modes Disable Register

Name: PIO_AIMDR

Address: 0x400E0EB4 (PIOA), 0x400E10B4 (PIOB), 0x400E12B4 (PIOC)

Access: Write-only

31	30	29	28	27	26	25	24
P31	P30	P29	P28	P27	P26	P25	P24
23	22	21	20	19	18	17	16
P23	P22	P21	P20	P19	P18	P17	P16
15	14	13	12	11	10	9	8
P15	P14	P13	P12	P11	P10	P9	P8
7	6	5	4	3	2	1	0
P7	P6	P5	P4	P3	P2	P1	P0

- **P0-P31: Additional Interrupt Modes Disable.**

0 = No effect.

1 = The interrupt mode is set to the default interrupt mode (Both Edge detection).

29.7.38 PIO Additional Interrupt Modes Mask Register

Name: PIO_AIMMR

Address: 0x400E0EB8 (PIOA), 0x400E10B8 (PIOB), 0x400E12B8 (PIOC)

Access: Read-only

31	30	29	28	27	26	25	24
P31	P30	P29	P28	P27	P26	P25	P24
23	22	21	20	19	18	17	16
P23	P22	P21	P20	P19	P18	P17	P16
15	14	13	12	11	10	9	8
P15	P14	P13	P12	P11	P10	P9	P8
7	6	5	4	3	2	1	0
P7	P6	P5	P4	P3	P2	P1	P0

- **P0-P31: Peripheral CD Status.**

0 = The interrupt source is a Both Edge detection event

1 = The interrupt source is described by the registers PIO_ELSR and PIO_FRLHSR

29.7.39 PIO Edge Select Register

Name: PIO_ESR

Address: 0x400E0EC0 (PIOA), 0x400E10C0 (PIOB), 0x400E12C0 (PIOC)

Access: Write-only

31	30	29	28	27	26	25	24
P31	P30	P29	P28	P27	P26	P25	P24
23	22	21	20	19	18	17	16
P23	P22	P21	P20	P19	P18	P17	P16
15	14	13	12	11	10	9	8
P15	P14	P13	P12	P11	P10	P9	P8
7	6	5	4	3	2	1	0
P7	P6	P5	P4	P3	P2	P1	P0

- **P0-P31: Edge Interrupt Selection.**

0 = No effect.

1 = The interrupt source is an Edge detection event.

29.7.40 PIO Level Select Register

Name: PIO_LSR

Address: 0x400E0EC4 (PIOA), 0x400E10C4 (PIOB), 0x400E12C4 (PIOC)

Access: Write-only

31	30	29	28	27	26	25	24
P31	P30	P29	P28	P27	P26	P25	P24
23	22	21	20	19	18	17	16
P23	P22	P21	P20	P19	P18	P17	P16
15	14	13	12	11	10	9	8
P15	P14	P13	P12	P11	P10	P9	P8
7	6	5	4	3	2	1	0
P7	P6	P5	P4	P3	P2	P1	P0

- **P0-P31: Level Interrupt Selection.**

0 = No effect.

1 = The interrupt source is a Level detection event.

29.7.41 PIO Edge/Level Status Register

Name: PIO_ELSR

Address: 0x400E0EC8 (PIOA), 0x400E10C8 (PIOB), 0x400E12C8 (PIOC)

Access: Read-only

31	30	29	28	27	26	25	24
P31	P30	P29	P28	P27	P26	P25	P24
23	22	21	20	19	18	17	16
P23	P22	P21	P20	P19	P18	P17	P16
15	14	13	12	11	10	9	8
P15	P14	P13	P12	P11	P10	P9	P8
7	6	5	4	3	2	1	0
P7	P6	P5	P4	P3	P2	P1	P0

- **P0-P31: Edge/Level Interrupt source selection.**

0 = The interrupt source is an Edge detection event.

1 = The interrupt source is a Level detection event.

29.7.42 PIO Falling Edge/Low Level Select Register

Name: PIO_FELLSR

Address: 0x400E0ED0 (PIOA), 0x400E10D0 (PIOB), 0x400E12D0 (PIOC)

Access: Write-only

31	30	29	28	27	26	25	24
P31	P30	P29	P28	P27	P26	P25	P24
23	22	21	20	19	18	17	16
P23	P22	P21	P20	P19	P18	P17	P16
15	14	13	12	11	10	9	8
P15	P14	P13	P12	P11	P10	P9	P8
7	6	5	4	3	2	1	0
P7	P6	P5	P4	P3	P2	P1	P0

- **P0-P31: Falling Edge/Low Level Interrupt Selection.**

0 = No effect.

1 = The interrupt source is set to a Falling Edge detection or Low Level detection event, depending on PIO_ELSR.

29.7.43 PIO Rising Edge/High Level Select Register

Name: PIO_REHLSR

Address: 0x400E0ED4 (PIOA), 0x400E10D4 (PIOB), 0x400E12D4 (PIOC)

Access: Write-only

31	30	29	28	27	26	25	24
P31	P30	P29	P28	P27	P26	P25	P24
23	22	21	20	19	18	17	16
P23	P22	P21	P20	P19	P18	P17	P16
15	14	13	12	11	10	9	8
P15	P14	P13	P12	P11	P10	P9	P8
7	6	5	4	3	2	1	0
P7	P6	P5	P4	P3	P2	P1	P0

- **P0-P31: Rising Edge /High Level Interrupt Selection.**

0 = No effect.

1 = The interrupt source is set to a Rising Edge detection or High Level detection event, depending on PIO_ELSR.

29.7.44 PIO Fall/Rise - Low/High Status Register

Name: PIO_FRLHSR

Address: 0x400E0ED8 (PIOA), 0x400E10D8 (PIOB), 0x400E12D8 (PIOC)

Access: Read-only

31	30	29	28	27	26	25	24
P31	P30	P29	P28	P27	P26	P25	P24
23	22	21	20	19	18	17	16
P23	P22	P21	P20	P19	P18	P17	P16
15	14	13	12	11	10	9	8
P15	P14	P13	P12	P11	P10	P9	P8
7	6	5	4	3	2	1	0
P7	P6	P5	P4	P3	P2	P1	P0

- **P0-P31: Edge /Level Interrupt Source Selection.**

0 = The interrupt source is a Falling Edge detection (if PIO_ELSR = 0) or Low Level detection event (if PIO_ELSR = 1).

1 = The interrupt source is a Rising Edge detection (if PIO_ELSR = 0) or High Level detection event (if PIO_ELSR = 1).



29.7.45 PIO Lock Status Register

Name: PIO_LOCKSR

Address: 0x400E0EE0 (PIOA), 0x400E10E0 (PIOB), 0x400E12E0 (PIOC)

Access: Read-only

31	30	29	28	27	26	25	24
P31	P30	P29	P28	P27	P26	P25	P24
23	22	21	20	19	18	17	16
P23	P22	P21	P20	P19	P18	P17	P16
15	14	13	12	11	10	9	8
P15	P14	P13	P12	P11	P10	P9	P8
7	6	5	4	3	2	1	0
P7	P6	P5	P4	P3	P2	P1	P0

- **P0-P31: Lock Status.**
0 = The I/O line is not locked.
1 = The I/O line is locked.

29.7.46 PIO Write Protect Mode Register

Name: PIO_WPMR

Address: 0x400E0EE4 (PIOA), 0x400E10E4 (PIOB), 0x400E12E4 (PIOC)

Access: Read-write

Reset: See [Table 29-3](#)

31	30	29	28	27	26	25	24
WPKEY							
23	22	21	20	19	18	17	16
WPKEY							
15	14	13	12	11	10	9	8
WPKEY							
7	6	5	4	3	2	1	0
-	-	-	-	-	-	-	WPEN

For more information on Write Protection Registers, refer to [Section 29.7 "Parallel Input/Output Controller \(PIO\) User Interface"](#).

- **WPEN: Write Protect Enable**

0 = Disables the Write Protect if WPKEY corresponds to 0x50494F ("PIO" in ASCII).

1 = Enables the Write Protect if WPKEY corresponds to 0x50494F ("PIO" in ASCII).

Protects the registers:

["PIO Enable Register" on page 556](#)

["PIO Disable Register" on page 556](#)

["PIO Output Enable Register" on page 557](#)

["PIO Output Disable Register" on page 558](#)

["PIO Input Filter Enable Register" on page 559](#)

["PIO Input Filter Disable Register" on page 559](#)

["PIO Multi-driver Enable Register" on page 564](#)

["PIO Multi-driver Disable Register" on page 565](#)

["PIO Pull Up Disable Register" on page 566](#)

["PIO Pull Up Enable Register" on page 566](#)

["PIO Peripheral ABCD Select Register 1" on page 568](#)

["PIO Peripheral ABCD Select Register 2" on page 569](#)

["PIO Output Write Enable Register" on page 574](#)

["PIO Output Write Disable Register" on page 574](#)

["PIO Pad Pull Down Disable Register" on page 572](#)

["PIO Pad Pull Down Status Register" on page 573](#)

["PIO Parallel Capture Mode Register" on page 584](#)

- **WPKEY: Write Protect KEY**

Should be written at value 0x50494F ("PIO" in ASCII). Writing any other value in this field aborts the write operation of the WPEN bit. Always reads as 0.

29.7.47 PIO Write Protect Status Register

Name: PIO_WPSR
Address: 0x400E0EE8 (PIOA), 0x400E10E8 (PIOB), 0x400E12E8 (PIOC)
Access: Read-only
Reset: See [Table 29-3](#)

31	30	29	28	27	26	25	24
–	–	–	–	–	–	–	–
23	22	21	20	19	18	17	16
WPVSR							
15	14	13	12	11	10	9	8
WPVSR							
7	6	5	4	3	2	1	0
–	–	–	–	–	–	–	WPVS

- WPVS: Write Protect Violation Status**

0 = No Write Protect Violation has occurred since the last read of the PIO_WPSR register.

1 = A Write Protect Violation has occurred since the last read of the PIO_WPSR register. If this violation is an unauthorized attempt to write a protected register, the associated violation is reported into field WPVSR.

- WPVSR: Write Protect Violation Source**

When WPVS is active, this field indicates the write-protected register (through address offset or code) in which a write access has been attempted.

Note: Reading PIO_WPSR automatically clears all fields.

29.7.48 PIO Schmitt Trigger Register

Name: PIO_SCHMITT

Address: 0x400E0F00 (PIOA), 0x400E1100 (PIOB), 0x400E1300 (PIOC)

Access: Read-write

Reset: See [Figure 29-3](#)

31	30	29	28	27	26	25	24
SCHMITT31	SCHMITT30	SCHMITT29	SCHMITT28	SCHMITT27	SCHMITT26	SCHMITT25	SCHMITT24
23	22	21	20	19	18	17	16
SCHMITT23	SCHMITT22	SCHMITT21	SCHMITT20	SCHMITT19	SCHMITT18	SCHMITT17	SCHMITT16
15	14	13	12	11	10	9	8
SCHMITT15	SCHMITT14	SCHMITT13	SCHMITT12	SCHMITT11	SCHMITT10	SCHMITT9	SCHMITT8
7	6	5	4	3	2	1	0
SCHMITT7	SCHMITT6	SCHMITT5	SCHMITT4	SCHMITT3	SCHMITT2	SCHMITT1	SCHMITT0

- **SCHMITTx [x=0..31]:**

0 = Schmitt Trigger is enabled.

1 = Schmitt Trigger is disabled.

29.7.49 PIO Parallel Capture Mode Register

Name: PIO_PCMR

Address: 0x400E0F50 (PIOA), 0x400E1150 (PIOB), 0x400E1350 (PIOC)

Access: Read-write

31	30	29	28	27	26	25	24
–	–	–	–	–	–	–	–
23	22	21	20	19	18	17	16
–	–	–	–	–	–	–	–
15	14	13	12	11	10	9	8
–	–	–	–	FRSTS	HALFS	ALWYS	–
7	6	5	4	3	2	1	0
–	–	DSIZE		–	–	–	PCEN

This register can only be written if the WPEN bit is cleared in “PIO Write Protect Mode Register” .

- **PCEN: Parallel Capture Mode Enable**

0 = The parallel capture mode is disabled.

1 = The parallel capture mode is enabled.

- **DSIZE: Parallel Capture Mode Data Size**

0 = The reception data in the PIO_PCRHR register is a BYTE (8-bit).

1 = The reception data in the PIO_PCRHR register is a HALF-WORD (16-bit).

2/3 = The reception data in the PIO_PCRHR register is a WORD (32-bit).

- **ALWYS: Parallel Capture Mode Always Sampling**

0 = The parallel capture mode samples the data when both data enables are active.

1 = The parallel capture mode samples the data whatever the data enables are.

- **HALFS: Parallel Capture Mode Half Sampling**

Independently from the ALWYS bit:

0 = The parallel capture mode samples all the data.

1 = The parallel capture mode samples the data only one time out of two.

- **FRSTS: Parallel Capture Mode First Sample**

This bit is useful only if the HALFS bit is set to 1. If data are numbered in the order that they are received with an index from 0 to n:

0 = Only data with an even index are sampled.

1 = Only data with an odd index are sampled.

29.7.50 PIO Parallel Capture Interrupt Enable Register

Name: PIO_PCIER

Address: 0x400E0F54 (PIOA), 0x400E1154 (PIOB), 0x400E1354 (PIOC)

Access: Write-only

31	30	29	28	27	26	25	24
–	–	–	–	–	–	–	–
23	22	21	20	19	18	17	16
–	–	–	–	–	–	–	–
15	14	13	12	11	10	9	8
–	–	–	–	–	–	–	–
7	6	5	4	3	2	1	0
–	–	–	–	RXBUFF	ENDRX	OVRE	DRDY

- **DRDY:** Parallel Capture Mode Data Ready Interrupt Enable
- **OVRE:** Parallel Capture Mode Overrun Error Interrupt Enable
- **ENDRX:** End of Reception Transfer Interrupt Enable
- **RXBUFF:** Reception Buffer Full Interrupt Enable

29.7.51 PIO Parallel Capture Interrupt Disable Register

Name: PIO_PCIDR

Address: 0x400E0F58 (PIOA), 0x400E1158 (PIOB), 0x400E1358 (PIOC)

Access: Write-only

31	30	29	28	27	26	25	24
–	–	–	–	–	–	–	–
23	22	21	20	19	18	17	16
–	–	–	–	–	–	–	–
15	14	13	12	11	10	9	8
–	–	–	–	–	–	–	–
7	6	5	4	3	2	1	0
–	–	–	–	RXBUFF	ENDRX	OVRE	DRDY

- **DRDY:** Parallel Capture Mode Data Ready Interrupt Disable
- **OVRE:** Parallel Capture Mode Overrun Error Interrupt Disable
- **ENDRX:** End of Reception Transfer Interrupt Disable
- **RXBUFF:** Reception Buffer Full Interrupt Disable

29.7.52 PIO Parallel Capture Interrupt Mask Register

Name: PIO_PCIMR

Address: 0x400E0F5C (PIOA), 0x400E115C (PIOB), 0x400E135C (PIOC)

Access: Read-only

31	30	29	28	27	26	25	24
–	–	–	–	–	–	–	–
23	22	21	20	19	18	17	16
–	–	–	–	–	–	–	–
15	14	13	12	11	10	9	8
–	–	–	–	–	–	–	–
7	6	5	4	3	2	1	0
–	–	–	–	RXBUFF	ENDRX	OVRE	DRDY

- **DRDY:** Parallel Capture Mode Data Ready Interrupt Mask
- **OVRE:** Parallel Capture Mode Overrun Error Interrupt Mask
- **ENDRX:** End of Reception Transfer Interrupt Mask
- **RXBUFF:** Reception Buffer Full Interrupt Mask

29.7.53 PIO Parallel Capture Interrupt Status Register

Name: PIO_PCISR

Address: 0x400E0F60 (PIOA), 0x400E1160 (PIOB), 0x400E1360 (PIOC)

Access: Read-only

31	30	29	28	27	26	25	24
–	–	–	–	–	–	–	–
23	22	21	20	19	18	17	16
–	–	–	–	–	–	–	–
15	14	13	12	11	10	9	8
–	–	–	–	–	–	–	–
7	6	5	4	3	2	1	0
–	–	–	–	RXBUFF	ENDRX	OVRE	DRDY

- **DRDY: Parallel Capture Mode Data Ready**

0: No new data is ready to be read since the last read of PIO_PCRHR.

1: A new data is ready to be read since the last read of PIO_PCRHR.

The DRDY flag is automatically reset when PIO_PCRHR is read or when the parallel capture mode is disabled.

- **OVRE: Parallel Capture Mode Overrun Error.**

0 = No overrun error occurred since the last read of this register.

1 = At least one overrun error occurred since the last read of this register.

The OVRE flag is automatically reset when this register is read or when the parallel capture mode is disabled.

- **ENDRX: End of Reception Transfer.**

0 = The End of Transfer signal from the Reception PDC channel is inactive.

1 = The End of Transfer signal from the Reception PDC channel is active.

- **RXBUFF: Reception Buffer Full**

0: The signal Buffer Full from the Reception PDC channel is inactive.

1: The signal Buffer Full from the Reception PDC channel is active.

29.7.54 PIO Parallel Capture Reception Holding Register

Name: PIO_PCRHR

Address: 0x400E0F64 (PIOA), 0x400E1164 (PIOB), 0x400E1364 (PIOC)

Access: Read-only

31	30	29	28	27	26	25	24
RDATA							
23	22	21	20	19	18	17	16
RDATA							
15	14	13	12	11	10	9	8
RDATA							
7	6	5	4	3	2	1	0
RDATA							

- **RDATA: Parallel Capture Mode Reception Data.**

If DSIZE = 0 in PIO_PCMR, only the 8 LSBs of RDATA are useful.

If DSIZE = 1 in PIO_PCMR, only the 16 LSBs of RDATA are useful.

30. Synchronous Serial Controller (SSC)

30.1 Description

The Atmel Synchronous Serial Controller (SSC) provides a synchronous communication link with external devices. It supports many serial synchronous communication protocols generally used in audio and telecom applications such as I2S, Short Frame Sync, Long Frame Sync, etc.

The SSC contains an independent receiver and transmitter and a common clock divider. The receiver and the transmitter each interface with three signals: the TD/RD signal for data, the TK/RK signal for the clock and the TF/RF signal for the Frame Sync. The transfers can be programmed to start automatically or on different events detected on the Frame Sync signal.

The SSC's high-level of programmability and its two dedicated PDC channels of up to 32 bits permit a continuous high bit rate data transfer without processor intervention.

Featuring connection to two PDC channels, the SSC permits interfacing with low processor overhead to the following:

- CODEC's in master or slave mode
- DAC through dedicated serial interface, particularly I2S
- Magnetic card reader

30.2 Embedded Characteristics

- Provides Serial Synchronous Communication Links Used in Audio and Telecom Applications
- Contains an Independent Receiver and Transmitter and a Common Clock Divider
- Interfaced with Two PDC Channels (DMA Access) to Reduce Processor Overhead
- Offers Configurable Frame Sync and Data Length
- Receiver and Transmitter Can be Programmed to Start Automatically or on Detection of Different Events on the Frame Sync Signal
- Receiver and Transmitter Include a Data Signal, a Clock Signal and a Frame Synchronization Signal

30.3 Block Diagram

Figure 30-1. Block Diagram

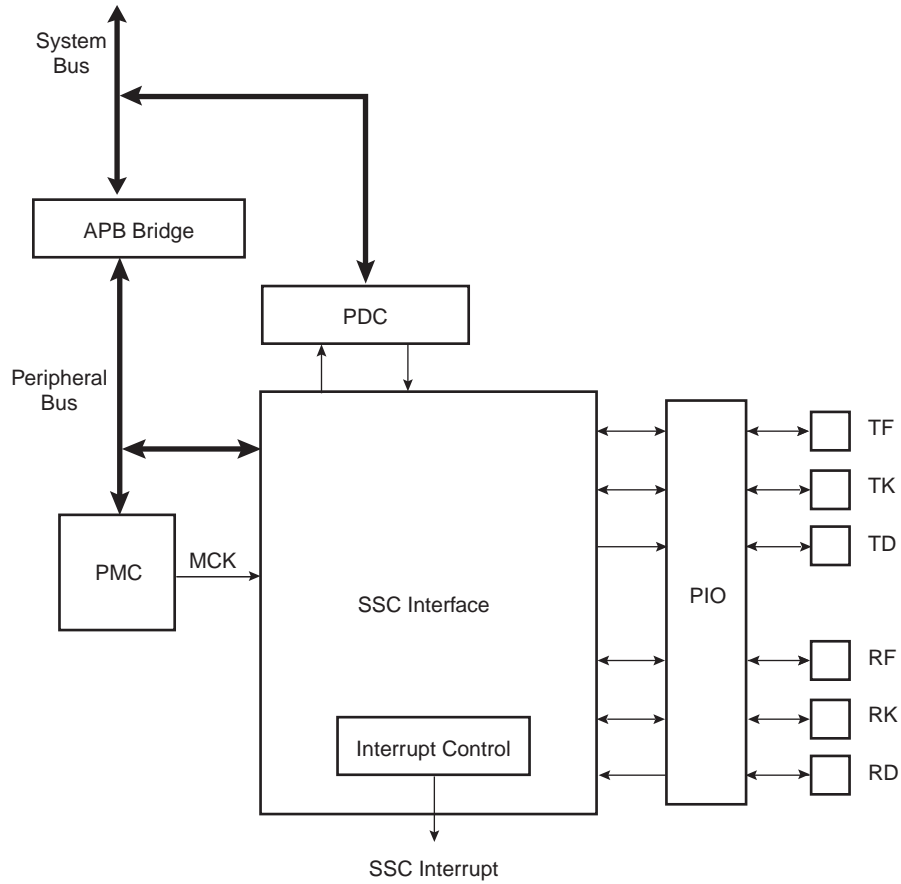

30.4 Application Block Diagram

Figure 30-2. Application Block Diagram

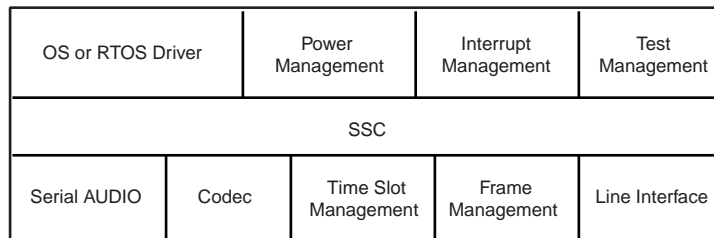

30.5 Pin Name List

Table 30-1. I/O Lines Description

Pin Name	Pin Description	Type
RF	Receiver Frame Synchro	Input/Output
RK	Receiver Clock	Input/Output
RD	Receiver Data	Input
TF	Transmitter Frame Synchro	Input/Output
TK	Transmitter Clock	Input/Output
TD	Transmitter Data	Output

30.6 Product Dependencies

30.6.1 I/O Lines

The pins used for interfacing the compliant external devices may be multiplexed with PIO lines. Before using the SSC receiver, the PIO controller must be configured to dedicate the SSC receiver I/O lines to the SSC peripheral mode.

Before using the SSC transmitter, the PIO controller must be configured to dedicate the SSC transmitter I/O lines to the SSC peripheral mode.

Table 30-2. I/O Lines

Instance	Signal	I/O Line	Peripheral
SSC	RD	PA18	A
SSC	RF	PA20	A
SSC	RK	PA19	A
SSC	TD	PA17	A
SSC	TF	PA15	A
SSC	TK	PA16	A

30.6.2 Power Management

The SSC is not continuously clocked. The SSC interface may be clocked through the Power Management Controller (PMC), therefore the programmer must first configure the PMC to enable the SSC clock.

30.6.3 Interrupt

The SSC interface has an interrupt line connected to the Nested Vector Interrupt Controller (NVIC). Handling interrupts requires programming the NVIC before configuring the SSC. All SSC interrupts can be enabled/disabled configuring the SSC Interrupt mask register. Each pending and unmasked SSC interrupt will assert the SSC interrupt line. The SSC interrupt service routine can get the interrupt origin by reading the SSC interrupt status register.

Table 30-3. Peripheral IDs

Instance	ID
SSC	22

30.7 Functional Description

This chapter contains the functional description of the following: SSC Functional Block, Clock Management, Data format, Start, Transmitter, Receiver and Frame Sync.

The receiver and transmitter operate separately. However, they can work synchronously by programming the receiver to use the transmit clock and/or to start a data transfer when transmission starts. Alternatively, this can be done by programming the transmitter to use the receive clock and/or to start a data transfer when reception starts. The transmitter and the receiver can be programmed to operate with the clock signals provided on either the TK or RK pins. This allows the SSC to support many slave-mode data transfers. The maximum clock speed allowed on the TK and RK pins is the master clock divided by 2.

Figure 30-3. SSC Functional Block Diagram

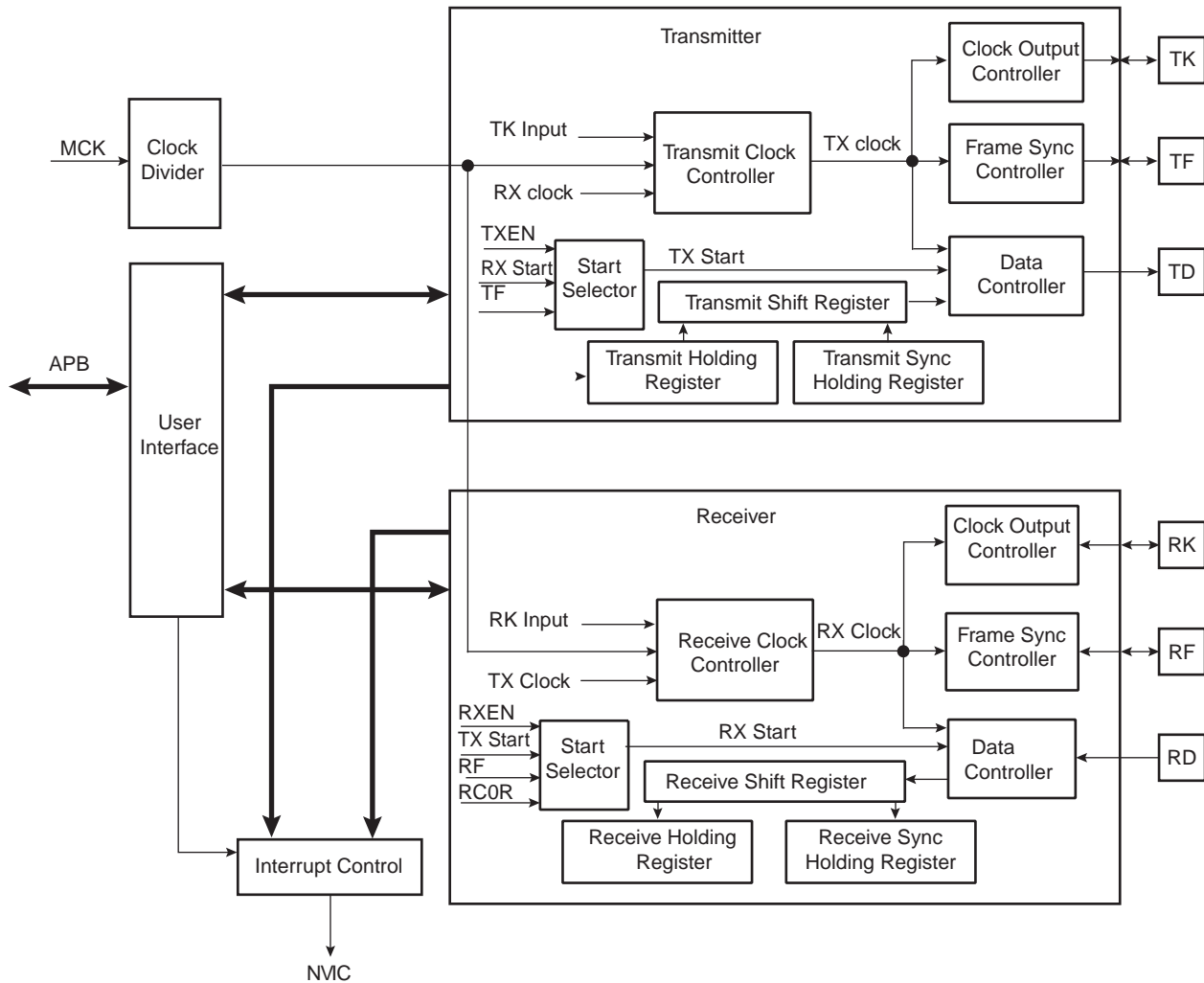

30.7.1 Clock Management

The transmitter clock can be generated by:

- An external clock received on the TK I/O pad
- The receiver clock
- The internal clock divider

The receiver clock can be generated by:

- An external clock received on the RK I/O pad
- The transmitter clock
- The internal clock divider

Furthermore, the transmitter block can generate an external clock on the TK I/O pad, and the receiver block can generate an external clock on the RK I/O pad.

This allows the SSC to support many Master and Slave Mode data transfers.

30.7.1.1 Clock Divider

Figure 30-4. Divided Clock Block Diagram

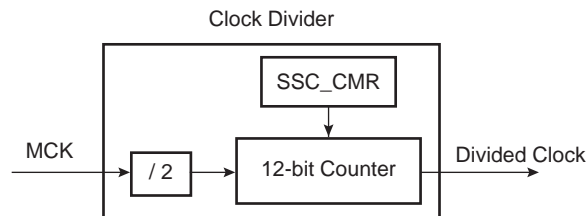

The Master Clock divider is determined by the 12-bit field DIV counter and comparator (so its maximal value is 4095) in the Clock Mode Register SSC_CMAR, allowing a Master Clock division by up to 8190. The Divided Clock is provided to both the Receiver and Transmitter. When this field is programmed to 0, the Clock Divider is not used and remains inactive.

When DIV is set to a value equal to or greater than 1, the Divided Clock has a frequency of Master Clock divided by 2 times DIV. Each level of the Divided Clock has a duration of the Master Clock multiplied by DIV. This ensures a 50% duty cycle for the Divided Clock regardless of whether the DIV value is even or odd.

Figure 30-5. Divided Clock Generation

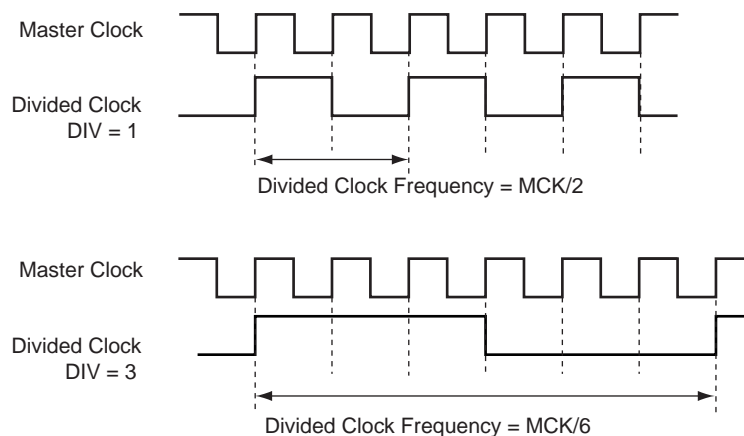

Table 30-4.

Maximum	Minimum
MCK / 2	MCK / 8190

30.7.1.2 Transmitter Clock Management

The transmitter clock is generated from the receiver clock or the divider clock or an external clock scanned on the TK I/O pad. The transmitter clock is selected by the CKS field in SSC_TCMR (Transmit Clock Mode Register). Transmit Clock can be inverted independently by the CKI bits in SSC_TCMR.

The transmitter can also drive the TK I/O pad continuously or be limited to the actual data transfer. The clock output is configured by the SSC_TCMR register. The Transmit Clock Inversion (CKI) bits have no effect on the clock outputs. Programming the TCMR register to select TK pin (CKS field) and at the same time Continuous Transmit Clock (CKO field) might lead to unpredictable results.

Figure 30-6. Transmitter Clock Management

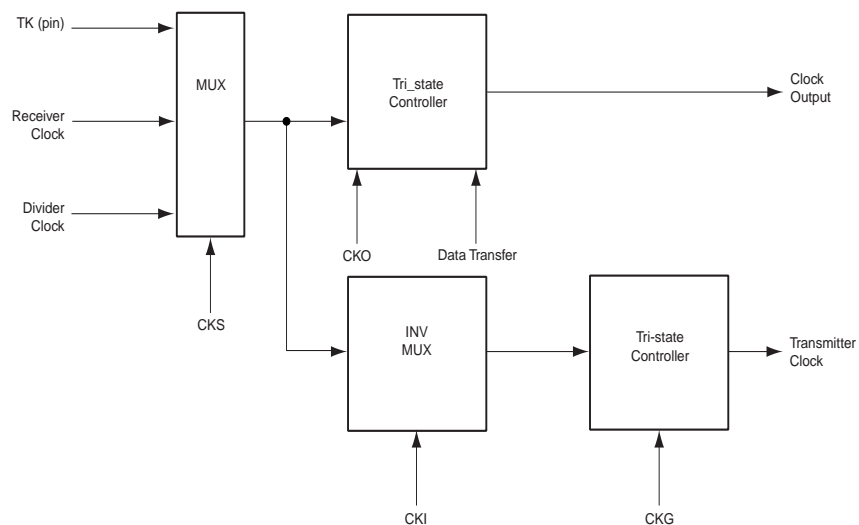

30.7.1.3 Receiver Clock Management

The receiver clock is generated from the transmitter clock or the divider clock or an external clock scanned on the RK I/O pad. The Receive Clock is selected by the CKS field in SSC_RCMR (Receive Clock Mode Register). Receive Clocks can be inverted independently by the CKI bits in SSC_RCMR.

The receiver can also drive the RK I/O pad continuously or be limited to the actual data transfer. The clock output is configured by the SSC_RCMR register. The Receive Clock Inversion (CKI) bits have no effect on the clock outputs. Programming the RCMR register to select RK pin (CKS field) and at the same time Continuous Receive Clock (CKO field) can lead to unpredictable results.

Figure 30-7. Receiver Clock Management

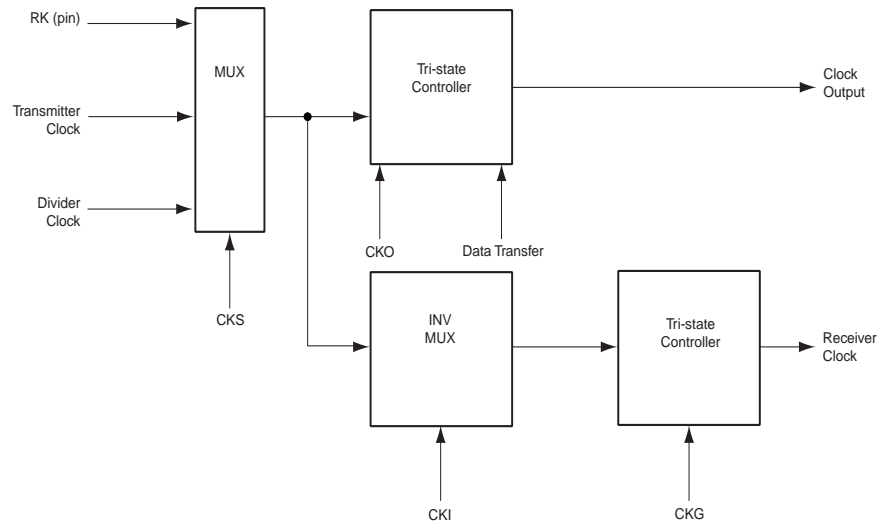

30.7.1.4 Serial Clock Ratio Considerations

The Transmitter and the Receiver can be programmed to operate with the clock signals provided on either the TK or RK pins. This allows the SSC to support many slave-mode data transfers. In this case, the maximum clock speed allowed on the RK pin is:

- Master Clock divided by 2 if Receiver Frame Synchro is input
- Master Clock divided by 3 if Receiver Frame Synchro is output

In addition, the maximum clock speed allowed on the TK pin is:

- Master Clock divided by 6 if Transmit Frame Synchro is input
- Master Clock divided by 2 if Transmit Frame Synchro is output

30.7.2 Transmitter Operations

A transmitted frame is triggered by a start event and can be followed by synchronization data before data transmission.

The start event is configured by setting the Transmit Clock Mode Register (SSC_TCMR). See [“Start” on page 597](#).

The frame synchronization is configured setting the Transmit Frame Mode Register (SSC_TFMR). See [“Frame Sync” on page 599](#).

To transmit data, the transmitter uses a shift register clocked by the transmitter clock signal and the start mode selected in the SSC_TCMR. Data is written by the application to the SSC_THR register then transferred to the shift register according to the data format selected.

When both the SSC_THR and the transmit shift register are empty, the status flag TXEMPTY is set in SSC_SR. When the Transmit Holding register is transferred in the Transmit shift register, the status flag TXRDY is set in SSC_SR and additional data can be loaded in the holding register.

Figure 30-8. Transmitter Block Diagram

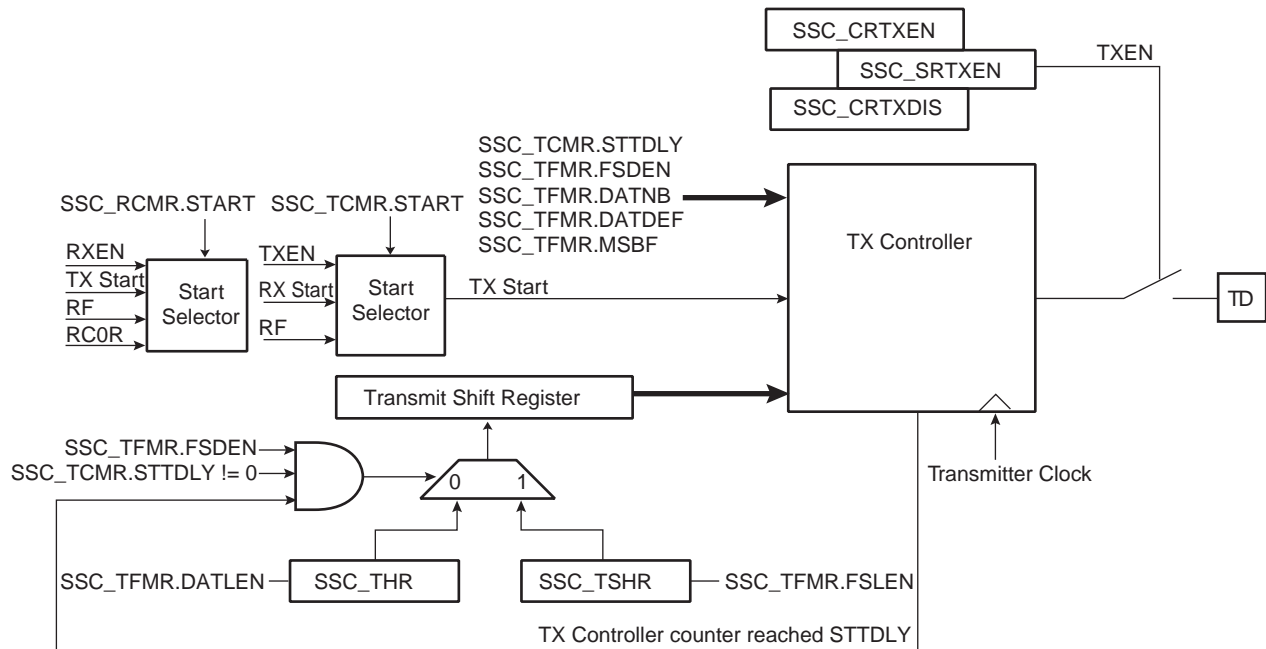

30.7.3 Receiver Operations

A received frame is triggered by a start event and can be followed by synchronization data before data transmission.

The start event is configured setting the Receive Clock Mode Register (SSC_RCMR). See “Start” on page 597.

The frame synchronization is configured setting the Receive Frame Mode Register (SSC_RFMR). See “Frame Sync” on page 599.

The receiver uses a shift register clocked by the receiver clock signal and the start mode selected in the SSC_RCMR. The data is transferred from the shift register depending on the data format selected.

When the receiver shift register is full, the SSC transfers this data in the holding register, the status flag RXRDY is set in SSC_SR and the data can be read in the receiver holding register. If another transfer occurs before read of the RHR register, the status flag OVERUN is set in SSC_SR and the receiver shift register is transferred in the RHR register.

Figure 30-9. Receiver Block Diagram

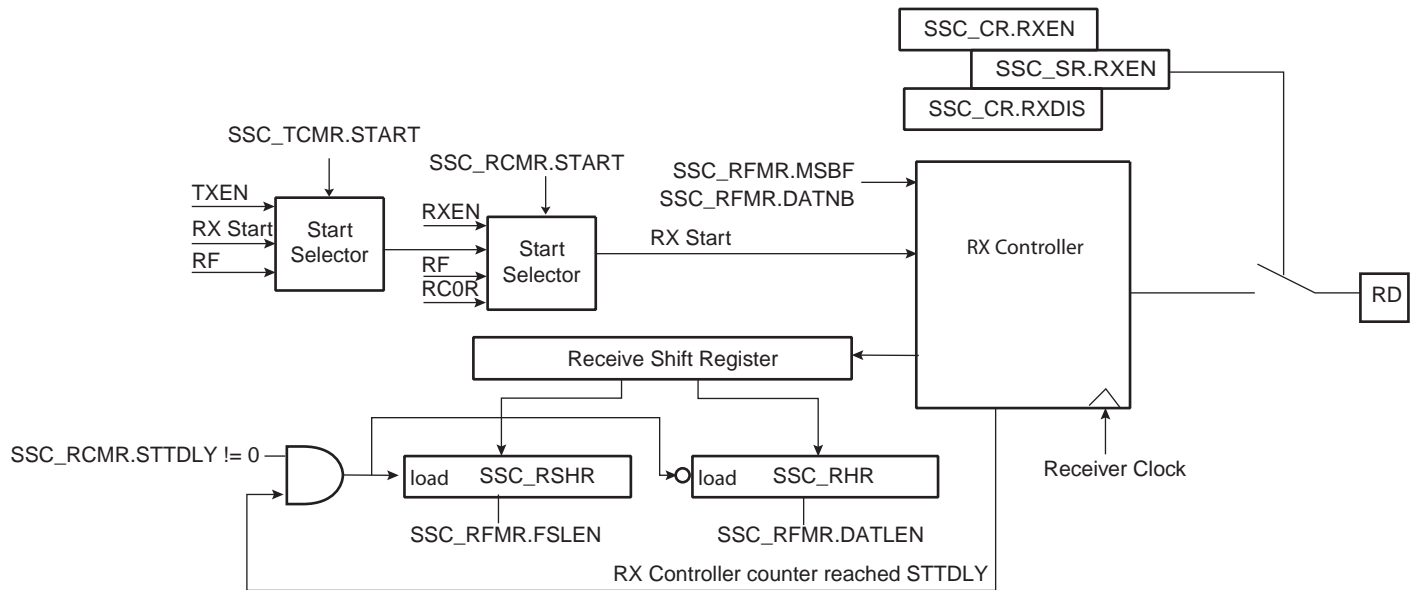

30.7.4 Start

The transmitter and receiver can both be programmed to start their operations when an event occurs, respectively in the Transmit Start Selection (START) field of SSC_TCMR and in the Receive Start Selection (START) field of SSC_RCMR.

Under the following conditions the start event is independently programmable:

- Continuous. In this case, the transmission starts as soon as a word is written in SSC_THR and the reception starts as soon as the Receiver is enabled.
- Synchronously with the transmitter/receiver
- On detection of a falling/rising edge on TF/RF
- On detection of a low level/high level on TF/RF
- On detection of a level change or an edge on TF/RF

A start can be programmed in the same manner on either side of the Transmit/Receive Clock Register (RCMR/TCMR). Thus, the start could be on TF (Transmit) or RF (Receive).

Moreover, the Receiver can start when data is detected in the bit stream with the Compare Functions.

Detection on TF/RF input/output is done by the field FSOS of the Transmit/Receive Frame Mode Register (TFMR/RFMR).

Figure 30-10. Transmit Start Mode

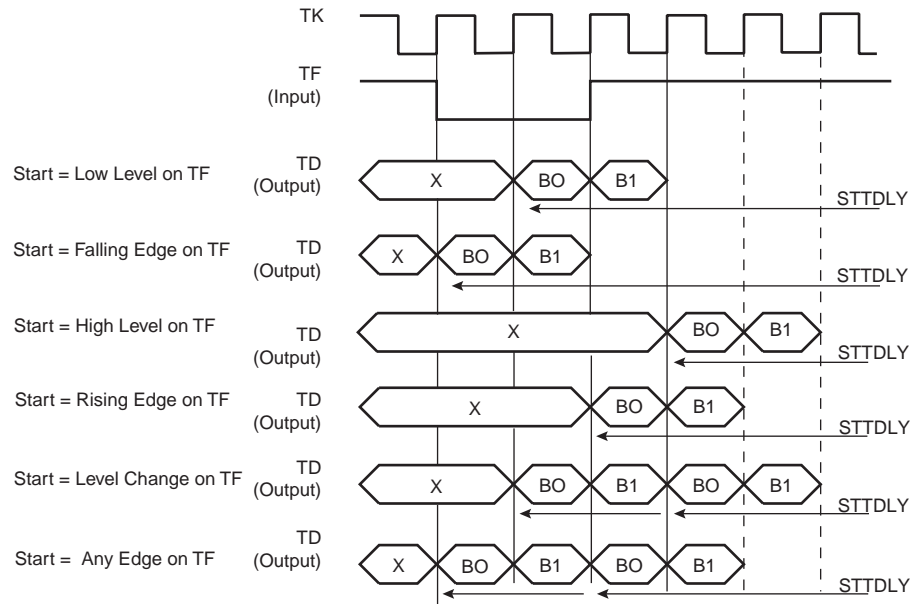
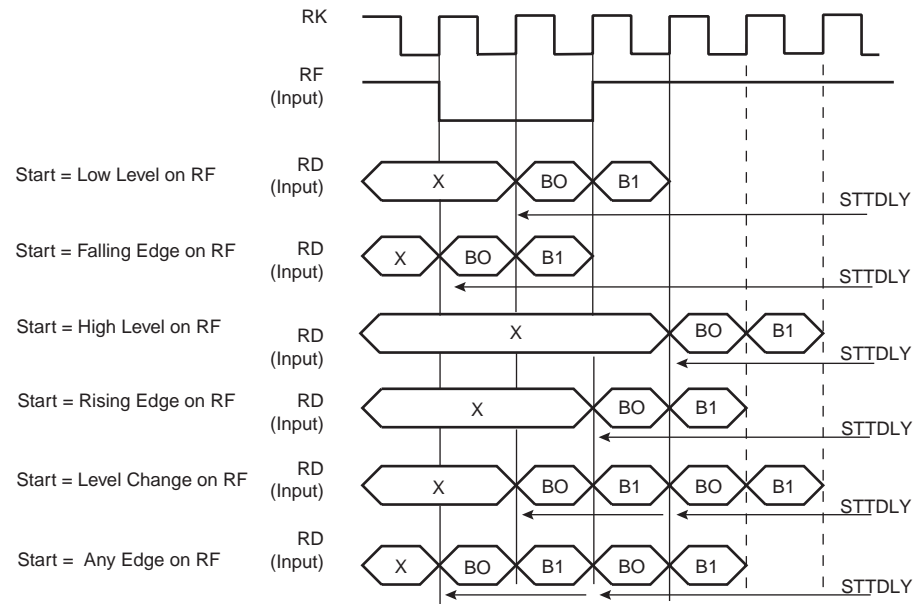

Figure 30-11. Receive Pulse/Edge Start Modes



30.7.5 Frame Sync

The Transmitter and Receiver Frame Sync pins, TF and RF, can be programmed to generate different kinds of frame synchronization signals. The Frame Sync Output Selection (FSOS) field in the Receive Frame Mode Register (SSC_RFMR) and in the Transmit Frame Mode Register (SSC_TFMR) are used to select the required waveform.

- Programmable low or high levels during data transfer are supported.
- Programmable high levels before the start of data transfers or toggling are also supported.

If a pulse waveform is selected, the Frame Sync Length (FSLEN) field in SSC_RFMR and SSC_TFMR programs the length of the pulse, from 1 bit time up to 256 bit time.

The periodicity of the Receive and Transmit Frame Sync pulse output can be programmed through the Period Divider Selection (PERIOD) field in SSC_RCMR and SSC_TCMR.

30.7.5.1 Frame Sync Data

Frame Sync Data transmits or receives a specific tag during the Frame Sync signal.

During the Frame Sync signal, the Receiver can sample the RD line and store the data in the Receive Sync Holding Register and the transmitter can transfer Transmit Sync Holding Register in the Shifter Register. The data length to be sampled/shifted out during the Frame Sync signal is programmed by the FSLEN field in SSC_RFMR/SSC_TFMR and has a maximum value of 16.

Concerning the Receive Frame Sync Data operation, if the Frame Sync Length is equal to or lower than the delay between the start event and the actual data reception, the data sampling operation is performed in the Receive Sync Holding Register through the Receive Shift Register.

The Transmit Frame Sync Operation is performed by the transmitter only if the bit Frame Sync Data Enable (FSDEN) in SSC_TFMR is set. If the Frame Sync length is equal to or lower than the delay between the start event and the actual data transmission, the normal transmission has priority and the data contained in the Transmit Sync Holding Register is transferred in the Transmit Register, then shifted out.

30.7.5.2 Frame Sync Edge Detection

The Frame Sync Edge detection is programmed by the FSEDGE field in SSC_RFMR/SSC_TFMR. This sets the corresponding flags RXSYN/TXSYN in the SSC Status Register (SSC_SR) on frame synchro edge detection (signals RF/TF).

30.7.6 Receive Compare Modes

Figure 30-12. Receive Compare Modes

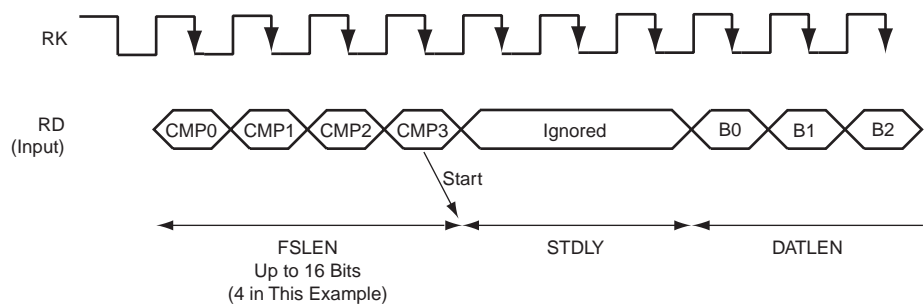

30.7.6.1 Compare Functions

Length of the comparison patterns (Compare 0, Compare 1) and thus the number of bits they are compared to is defined by FSLEN, but with a maximum value of 16 bits. Comparison is always done by comparing the last bits received with the comparison pattern. Compare 0 can be one start event of the Receiver. In this case, the receiver compares at each new sample the last bits received at the Compare 0 pattern contained in the Compare 0 Register (SSC_RC0R). When this start event is selected, the user can program the Receiver to start a new data transfer either by writing a new Compare 0, or by receiving continuously until Compare 1 occurs. This selection is done with the bit (STOP) in SSC_RCMR.

30.7.7 Data Format

The data framing format of both the transmitter and the receiver are programmable through the Transmitter Frame Mode Register (SSC_TFMR) and the Receiver Frame Mode Register (SSC_RFMR). In either case, the user can independently select:

- the event that starts the data transfer (START)
- the delay in number of bit periods between the start event and the first data bit (STTDLY)
- the length of the data (DATLEN)
- the number of data to be transferred for each start event (DATNB).
- the length of synchronization transferred for each start event (FSLEN)
- the bit sense: most or lowest significant bit first (MSBF)

Additionally, the transmitter can be used to transfer synchronization and select the level driven on the TD pin while not in data transfer operation. This is done respectively by the Frame Sync Data Enable (FSDEN) and by the Data Default Value (DATDEF) bits in SSC_TFMR.

Table 30-5. Data Frame Registers

Transmitter	Receiver	Field	Length	Comment
SSC_TFMR	SSC_RFMR	DATLEN	Up to 32	Size of word
SSC_TFMR	SSC_RFMR	DATNB	Up to 16	Number of words transmitted in frame
SSC_TFMR	SSC_RFMR	MSBF		Most significant bit first
SSC_TFMR	SSC_RFMR	FSLEN	Up to 16	Size of Synchro data register
SSC_TFMR		DATDEF	0 or 1	Data default value ended
SSC_TFMR		FSDEN		Enable send SSC_TSHR
SSC_TCMR	SSC_RCMR	PERIOD	Up to 512	Frame size
SSC_TCMR	SSC_RCMR	STTDLY	Up to 255	Size of transmit start delay

Figure 30-13. Transmit and Receive Frame Format in Edge/Pulse Start Modes

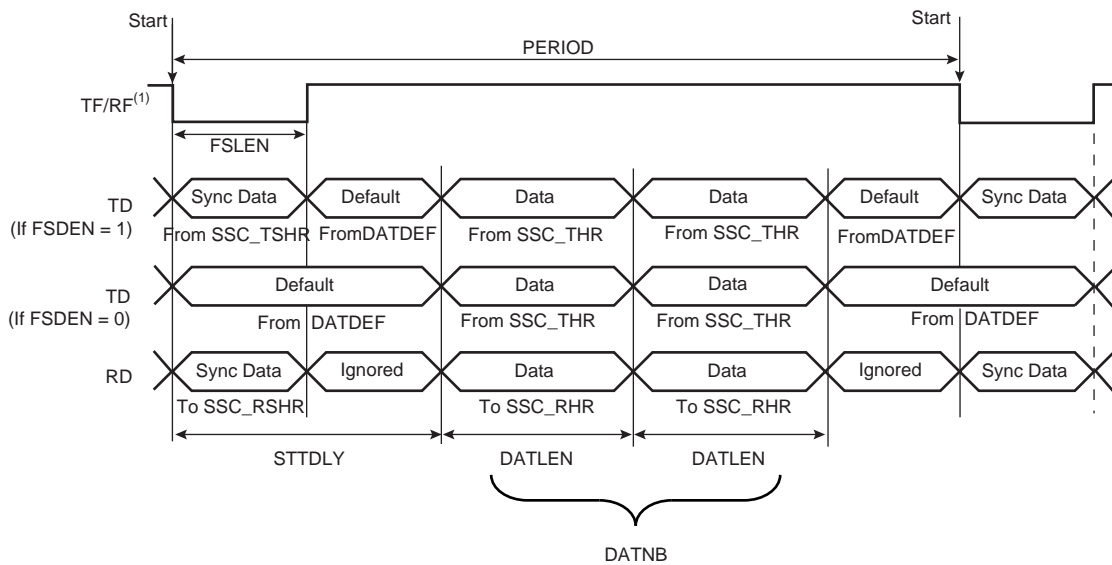

Note: 1. Example of input on falling edge of TF/RF.

Figure 30-14. Transmit Frame Format in Continuous Mode

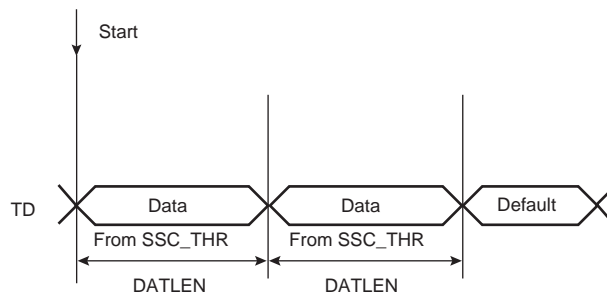

Start: 1. TXEMPTY set to 1
2. Write into the SSC_THR

Note: 1. STTDLY is set to 0. In this example, SSC_THR is loaded twice. FSDEN value has no effect on the transmission. SyncData cannot be output in continuous mode.

Figure 30-15. Receive Frame Format in Continuous Mode

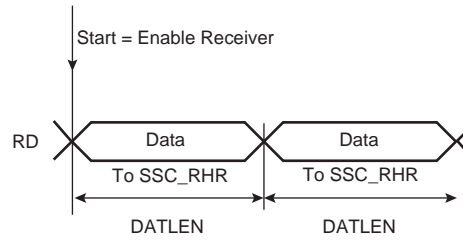

Note: 1. STTDLY is set to 0.

30.7.8 Loop Mode

The receiver can be programmed to receive transmissions from the transmitter. This is done by setting the Loop Mode (LOOP) bit in SSC_RFMR. In this case, RD is connected to TD, RF is connected to TF and RK is connected to TK.

30.7.9 Interrupt

Most bits in SSC_SR have a corresponding bit in interrupt management registers.

The SSC can be programmed to generate an interrupt when it detects an event. The interrupt is controlled by writing SSC_IER (Interrupt Enable Register) and SSC_IDR (Interrupt Disable Register). These registers enable and disable, respectively, the corresponding interrupt by setting and clearing the corresponding bit in SSC_IMR (Interrupt Mask Register), which controls the generation of interrupts by asserting the SSC interrupt line connected to the NVIC.

Figure 30-16. Interrupt Block Diagram

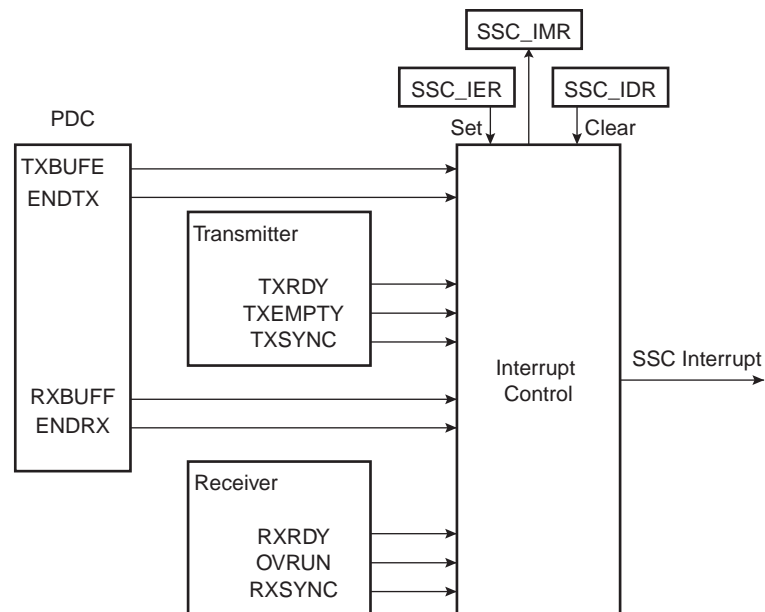

30.8 SSC Application Examples

The SSC can support several serial communication modes used in audio or high speed serial links. Some standard applications are shown in the following figures. All serial link applications supported by the SSC are not listed here.

Figure 30-17. Audio Application Block Diagram

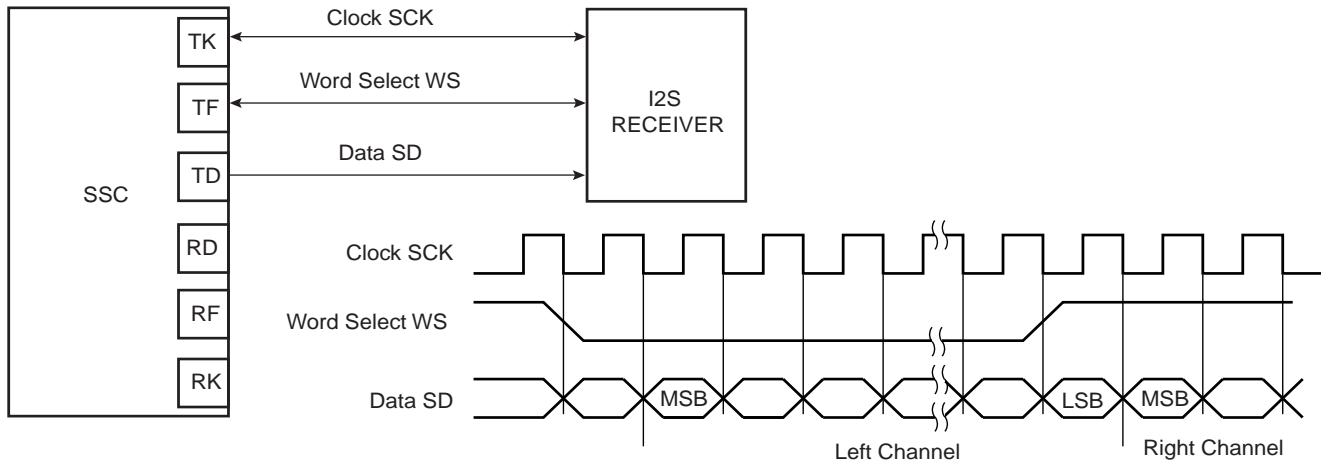

Figure 30-18. Codec Application Block Diagram

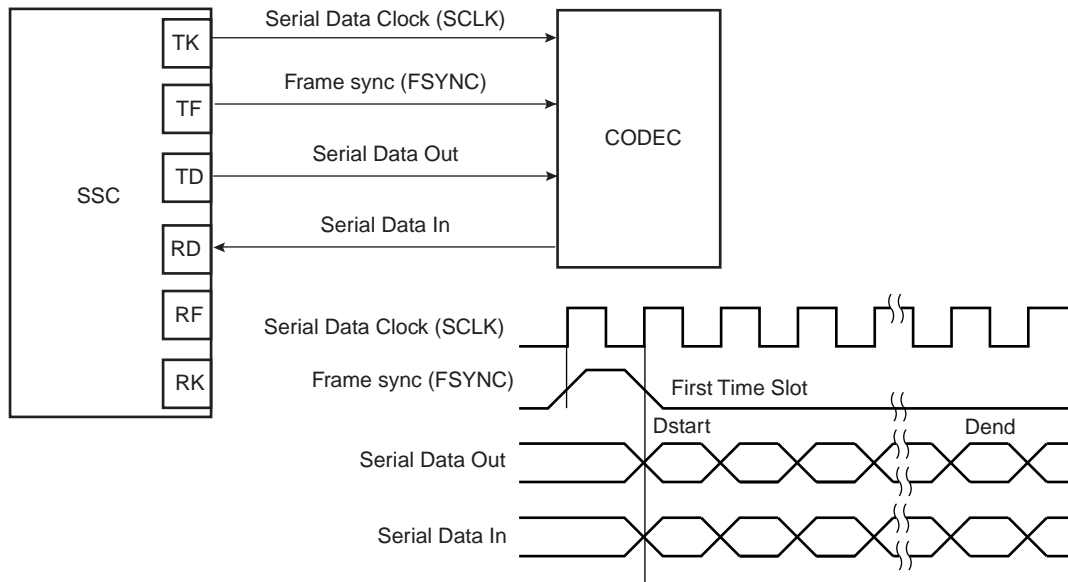
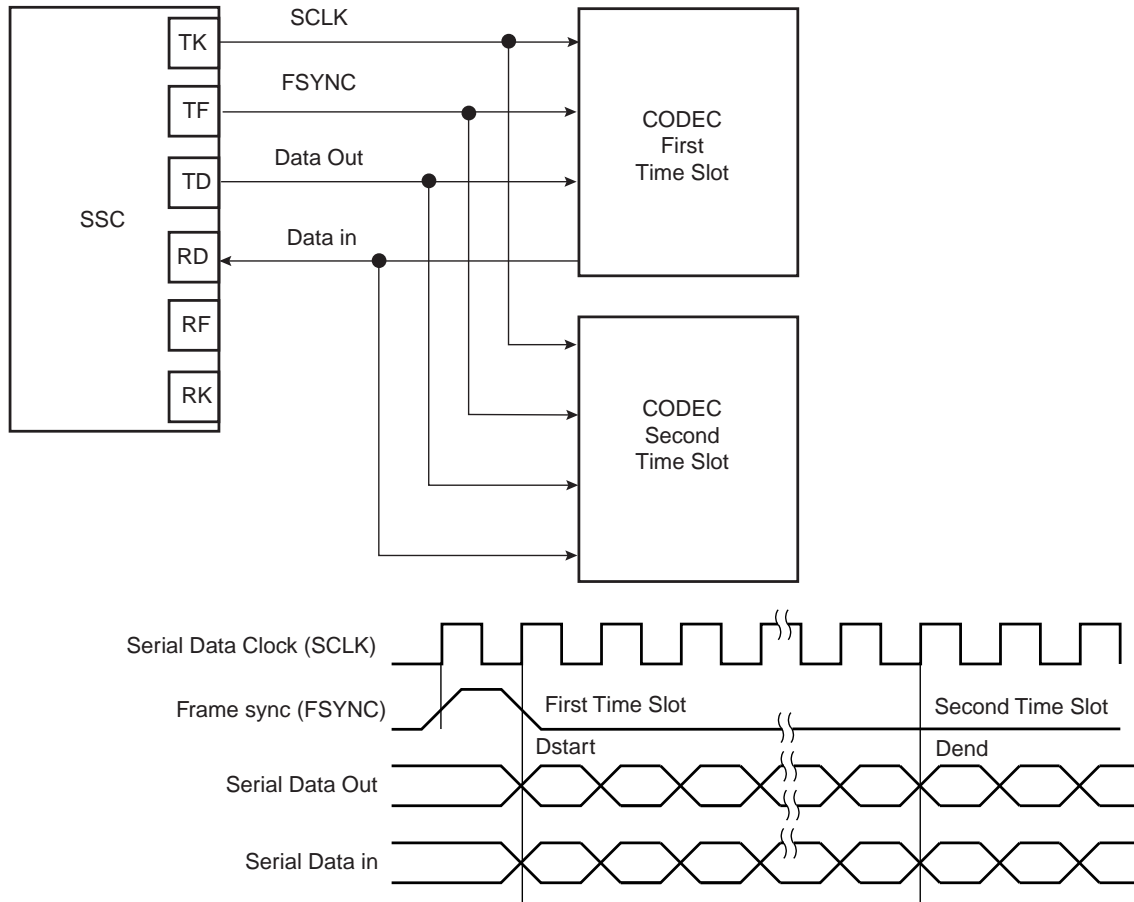

Figure 30-19. Time Slot Application Block Diagram



30.8.1 Write Protection Registers

To prevent any single software error that may corrupt SSC behavior, certain address spaces can be write-protected by setting the WPEN bit in the “[SSC Write Protect Mode Register](#)” (SSC_WPMR).

If a write access to the protected registers is detected, then the WPVS flag in the SSC Write Protect Status Register (US_WPSR) is set and the field WPVSR indicates in which register the write access has been attempted.

The WPVS flag is reset by writing the SSC Write Protect Mode Register (SSC_WPMR) with the appropriate access key, WPKEY.

The protected registers are:

- “[SSC Clock Mode Register](#)” on page 608
- “[SSC Receive Clock Mode Register](#)” on page 609
- “[SSC Receive Frame Mode Register](#)” on page 611
- “[SSC Transmit Clock Mode Register](#)” on page 613
- “[SSC Transmit Frame Mode Register](#)” on page 615
- “[SSC Receive Compare 0 Register](#)” on page 621
- “[SSC Receive Compare 1 Register](#)” on page 622

30.9 Synchronous Serial Controller (SSC) User Interface

Table 30-6. Register Mapping

Offset	Register	Name	Access	Reset
0x0	Control Register	SSC_CR	Write-only	–
0x4	Clock Mode Register	SSC_CMR	Read-write	0x0
0x8	Reserved	–	–	–
0xC	Reserved	–	–	–
0x10	Receive Clock Mode Register	SSC_RCMR	Read-write	0x0
0x14	Receive Frame Mode Register	SSC_RFMR	Read-write	0x0
0x18	Transmit Clock Mode Register	SSC_TCMR	Read-write	0x0
0x1C	Transmit Frame Mode Register	SSC_TFMR	Read-write	0x0
0x20	Receive Holding Register	SSC_RHR	Read-only	0x0
0x24	Transmit Holding Register	SSC_THR	Write-only	–
0x28	Reserved	–	–	–
0x2C	Reserved	–	–	–
0x30	Receive Sync. Holding Register	SSC_RSHR	Read-only	0x0
0x34	Transmit Sync. Holding Register	SSC_TSHR	Read-write	0x0
0x38	Receive Compare 0 Register	SSC_RC0R	Read-write	0x0
0x3C	Receive Compare 1 Register	SSC_RC1R	Read-write	0x0
0x40	Status Register	SSC_SR	Read-only	0x000000CC
0x44	Interrupt Enable Register	SSC_IER	Write-only	–
0x48	Interrupt Disable Register	SSC_IDR	Write-only	–
0x4C	Interrupt Mask Register	SSC_IMR	Read-only	0x0
0xE4	Write Protect Mode Register	SSC_WPMR	Read-write	0x0
0xE8	Write Protect Status Register	SSC_WPSR	Read-only	0x0
0x50-0xFC	Reserved	–	–	–
0x100- 0x124	Reserved for Peripheral Data Controller (PDC)	–	–	–

30.9.1 SSC Control Register

Name: SSC_CR:
Address: 0x40004000
Access: Write-only

31	30	29	28	27	26	25	24
–	–	–	–	–	–	–	–
23	22	21	20	19	18	17	16
–	–	–	–	–	–	–	–
15	14	13	12	11	10	9	8
SWRST	–	–	–	–	–	TXDIS	TXEN
7	6	5	4	3	2	1	0
–	–	–	–	–	–	RXDIS	RXEN

- **RXEN: Receive Enable**

0 = No effect.

1 = Enables Receive if RXDIS is not set.

- **RXDIS: Receive Disable**

0 = No effect.

1 = Disables Receive. If a character is currently being received, disables at end of current character reception.

- **TXEN: Transmit Enable**

0 = No effect.

1 = Enables Transmit if TXDIS is not set.

- **TXDIS: Transmit Disable**

0 = No effect.

1 = Disables Transmit. If a character is currently being transmitted, disables at end of current character transmission.

- **SWRST: Software Reset**

0 = No effect.

1 = Performs a software reset. Has priority on any other bit in SSC_CR.

30.9.2 SSC Clock Mode Register

Name: SSC_CMCR

Address: 0x40004004

Access: Read-write

31	30	29	28	27	26	25	24
–	–	–	–	–	–	–	–
23	22	21	20	19	18	17	16
–	–	–	–	–	–	–	–
15	14	13	12	11	10	9	8
–	–	–	–	DIV			
7	6	5	4	3	2	1	0
DIV							

This register can only be written if the WPEN bit is cleared in [“SSC Write Protect Mode Register”](#) .

- **DIV: Clock Divider**

0 = The Clock Divider is not active.

Any Other Value: The Divided Clock equals the Master Clock divided by 2 times DIV. The maximum bit rate is MCK/2. The minimum bit rate is $MCK/2 \times 4095 = MCK/8190$.

30.9.3 SSC Receive Clock Mode Register

Name: SSC_RCMR

Address: 0x40004010

Access: Read-write

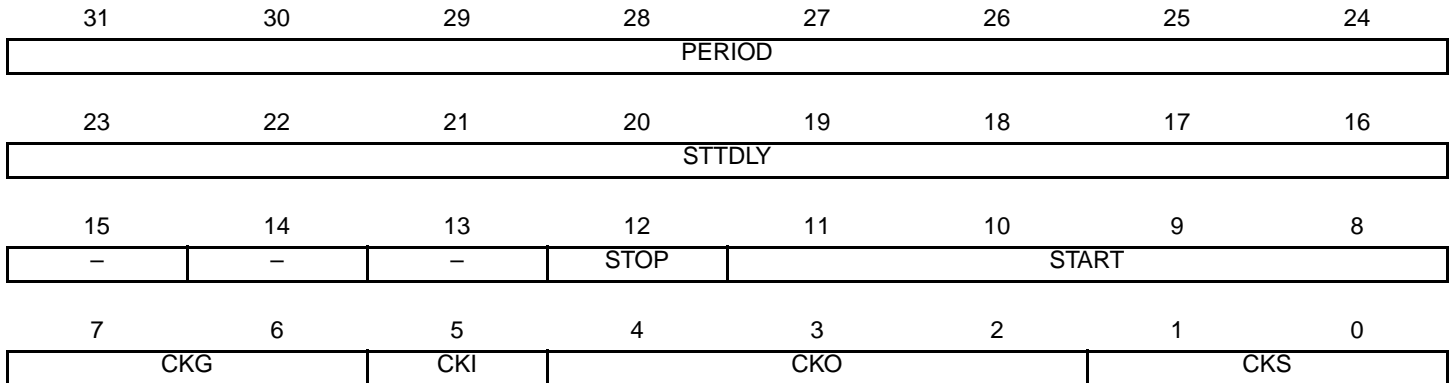

This register can only be written if the WPEN bit is cleared in [“SSC Write Protect Mode Register”](#).

• **CKS: Receive Clock Selection**

Value	Name	Description
0	MCK	Divided Clock
1	TK	TK Clock signal
2	RK	RK pin
3		Reserved

• **CKO: Receive Clock Output Mode Selection**

Value	Name	Description	RK Pin
0	NONE	None	Input-only
1	CONTINUOUS	Continuous Receive Clock	Output
2	TRANSFER	Receive Clock only during data transfers	Output
3-7		Reserved	

• **CKI: Receive Clock Inversion**

0 = The data inputs (Data and Frame Sync signals) are sampled on Receive Clock falling edge. The Frame Sync signal output is shifted out on Receive Clock rising edge.

1 = The data inputs (Data and Frame Sync signals) are sampled on Receive Clock rising edge. The Frame Sync signal output is shifted out on Receive Clock falling edge.

CKI affects only the Receive Clock and not the output clock signal.

• **CKG: Receive Clock Gating Selection**

Value	Name	Description	RK Pin
0	NONE	None	Input-only
1	CONTINUOUS	Continuous Receive Clock	Output
2	TRANSFER	Receive Clock only during data transfers	Output
3-7		Reserved	

• **START: Receive Start Selection**

Value	Name	Description
0	CONTINUOUS	Continuous, as soon as the receiver is enabled, and immediately after the end of transfer of the previous data.
1	TRANSMIT	Transmit start
2	RF_LOW	Detection of a low level on RF signal
3	RF_HIGH	Detection of a high level on RF signal
4	RF_FALLING	Detection of a falling edge on RF signal
5	RF_RISING	Detection of a rising edge on RF signal
6	RF_LEVEL	Detection of any level change on RF signal
7	RF_EDGE	Detection of any edge on RF signal
8	CMP_0	Compare 0

• **STOP: Receive Stop Selection**

0 = After completion of a data transfer when starting with a Compare 0, the receiver stops the data transfer and waits for a new compare 0.

1 = After starting a receive with a Compare 0, the receiver operates in a continuous mode until a Compare 1 is detected.

• **STTDLY: Receive Start Delay**

If STTDLY is not 0, a delay of STTDLY clock cycles is inserted between the start event and the actual start of reception. When the Receiver is programmed to start synchronously with the Transmitter, the delay is also applied.

Note: It is very important that STTDLY be set carefully. If STTDLY must be set, it should be done in relation to TAG (Receive Sync Data) reception.

• **PERIOD: Receive Period Divider Selection**

This field selects the divider to apply to the selected Receive Clock in order to generate a new Frame Sync Signal. If 0, no PERIOD signal is generated. If not 0, a PERIOD signal is generated each 2 x (PERIOD+1) Receive Clock.

30.9.4 SSC Receive Frame Mode Register

Name: SSC_RFMR

Address: 0x40004014

Access: Read-write

31	30	29	28	27	26	25	24
FSLEN_EXT	FSLEN_EXT	FSLEN_EXT	FSLEN_EXT	–	–	–	FSEDGE
23	22	21	20	19	18	17	16
–	FSOS			FSLEN			
15	14	13	12	11	10	9	8
–	–	–	–	DATNB			
7	6	5	4	3	2	1	0
MSBF	–	LOOP	DATLEN				

This register can only be written if the WPEN bit is cleared in [“SSC Write Protect Mode Register”](#).

- **DATLEN: Data Length**

0 = Forbidden value (1-bit data length not supported).

Any other value: The bit stream contains DATLEN + 1 data bits. Moreover, it defines the transfer size performed by the PDC assigned to the Receiver. If DATLEN is lower or equal to 7, data transfers are in bytes. If DATLEN is between 8 and 15 (included), half-words are transferred, and for any other value, 32-bit words are transferred.

- **LOOP: Loop Mode**

0 = Normal operating mode.

1 = RD is driven by TD, RF is driven by TF and TK drives RK.

- **MSBF: Most Significant Bit First**

0 = The lowest significant bit of the data register is sampled first in the bit stream.

1 = The most significant bit of the data register is sampled first in the bit stream.

- **DATNB: Data Number per Frame**

This field defines the number of data words to be received after each transfer start, which is equal to (DATNB + 1).

- **FSLEN: Receive Frame Sync Length**

This field defines the number of bits sampled and stored in the Receive Sync Data Register. When this mode is selected by the START field in the Receive Clock Mode Register, it also determines the length of the sampled data to be compared to the Compare 0 or Compare 1 register.

This field is used with FSLEN_EXT to determine the pulse length of the Receive Frame Sync signal.

Pulse length is equal to FSLEN + (FSLEN_EXT * 16) + 1 Receive Clock periods.

- **FSOS: Receive Frame Sync Output Selection**

Value	Name	Description	RF Pin
0	NONE	None	Input-only
1	NEGATIVE	Negative Pulse	Output
2	POSITIVE	Positive Pulse	Output
3	LOW	Driven Low during data transfer	Output
4	HIGH	Driven High during data transfer	Output
5	TOGGLING	Toggling at each start of data transfer	Output
6-7		Reserved	Undefined

- **FSEDGE: Frame Sync Edge Detection**

Determines which edge on Frame Sync will generate the interrupt RXSYN in the SSC Status Register.

Value	Name	Description
0	POSITIVE	Positive Edge Detection
1	NEGATIVE	Negative Edge Detection

- **FSLEN_EXT: FSLEN Field Extension**

Extends FSLEN field. For details, refer to FSLEN bit description on [page 611](#).

30.9.5 SSC Transmit Clock Mode Register

Name: SSC_TCMR

Address: 0x40004018

Access: Read-write

31	30	29	28	27	26	25	24
PERIOD							
23	22	21	20	19	18	17	16
STTDLY							
15	14	13	12	11	10	9	8
-				START			
7	6	5	4	3	2	1	0
CKG		CKI	CKO			CKS	

This register can only be written if the WPEN bit is cleared in [“SSC Write Protect Mode Register”](#).

• CKS: Transmit Clock Selection

Value	Name	Description
0	MCK	Divided Clock
1	TK	TK Clock signal
2	RK	RK pin
3		Reserved

• CKO: Transmit Clock Output Mode Selection

Value	Name	Description	TK Pin
0	NONE	None	Input-only
1	CONTINUOUS	Continuous Receive Clock	Output
2	TRANSFER	Transmit Clock only during data transfers	Output
3-7		Reserved	

• CKI: Transmit Clock Inversion

0 = The data outputs (Data and Frame Sync signals) are shifted out on Transmit Clock falling edge. The Frame sync signal input is sampled on Transmit clock rising edge.

1 = The data outputs (Data and Frame Sync signals) are shifted out on Transmit Clock rising edge. The Frame sync signal input is sampled on Transmit clock falling edge.

CKI affects only the Transmit Clock and not the output clock signal.

- **CKG: Transmit Clock Gating Selection**

Value	Name	Description
0	NONE	None
1	CONTINUOUS	Transmit Clock enabled only if TF Low
2	TRANSFER	Transmit Clock enabled only if TF High

- **START: Transmit Start Selection**

Value	Name	Description
0	CONTINUOUS	Continuous, as soon as a word is written in the SSC_THR Register (if Transmit is enabled), and immediately after the end of transfer of the previous data.
1	RECEIVE	Receive start
2	RF_LOW	Detection of a low level on TF signal
3	RF_HIGH	Detection of a high level on TF signal
4	RF_FALLING	Detection of a falling edge on TF signal
5	RF_RISING	Detection of a rising edge on TF signal
6	RF_LEVEL	Detection of any level change on TF signal
7	RF_EDGE	Detection of any edge on TF signal
8	CMP_0	Compare 0

- **STTDLY: Transmit Start Delay**

If STTDLY is not 0, a delay of STTDLY clock cycles is inserted between the start event and the actual start of transmission of data. When the Transmitter is programmed to start synchronously with the Receiver, the delay is also applied.

Note: STTDLY must be set carefully. If STTDLY is too short in respect to TAG (Transmit Sync Data) emission, data is emitted instead of the end of TAG.

- **PERIOD: Transmit Period Divider Selection**

This field selects the divider to apply to the selected Transmit Clock to generate a new Frame Sync Signal. If 0, no period signal is generated. If not 0, a period signal is generated at each $2 \times (\text{PERIOD} + 1)$ Transmit Clock.

30.9.6 SSC Transmit Frame Mode Register

Name: SSC_TFMR
Address: 0x4000401C
Access: Read-write

31	30	29	28	27	26	25	24
FSLEN_EXT	FSLEN_EXT	FSLEN_EXT	FSLEN_EXT	–	–	–	FSEDGE
23	22	21	20	19	18	17	16
FSDEN	FSOS			FSLEN			
15	14	13	12	11	10	9	8
–	–	–	–	DATNB			
7	6	5	4	3	2	1	0
MSBF	–	DATDEF	DATLEN				

This register can only be written if the WPEN bit is cleared in [“SSC Write Protect Mode Register”](#).

- **DATLEN: Data Length**

0 = Forbidden value (1-bit data length not supported).

Any other value: The bit stream contains DATLEN + 1 data bits. Moreover, it defines the transfer size performed by the PDC assigned to the Transmit. If DATLEN is lower or equal to 7, data transfers are bytes, if DATLEN is between 8 and 15 (included), half-words are transferred, and for any other value, 32-bit words are transferred.

- **DATDEF: Data Default Value**

This bit defines the level driven on the TD pin while out of transmission. Note that if the pin is defined as multi-drive by the PIO Controller, the pin is enabled only if the SCC TD output is 1.

- **MSBF: Most Significant Bit First**

0 = The lowest significant bit of the data register is shifted out first in the bit stream.

1 = The most significant bit of the data register is shifted out first in the bit stream.

- **DATNB: Data Number per frame**

This field defines the number of data words to be transferred after each transfer start, which is equal to (DATNB +1).

- **FSLEN: Transmit Frame Sync Length**

This field defines the length of the Transmit Frame Sync signal and the number of bits shifted out from the Transmit Sync Data Register if FSDEN is 1.

This field is used with FSLEN_EXT to determine the pulse length of the Transmit Frame Sync signal.

Pulse length is equal to FSLEN + (FSLEN_EXT * 16) + 1 Transmit Clock period.

- **FSOS: Transmit Frame Sync Output Selection**

Value	Name	Description	RF Pin
0	NONE	None	Input-only
1	NEGATIVE	Negative Pulse	Output
2	POSITIVE	Positive Pulse	Output
3	LOW	Driven Low during data transfer	Output
4	HIGH	Driven High during data transfer	Output
5	TOGGLING	Toggling at each start of data transfer	Output
6-7		Reserved	Undefined

- **FSDEN: Frame Sync Data Enable**

0 = The TD line is driven with the default value during the Transmit Frame Sync signal.

1 = SSC_TSHR value is shifted out during the transmission of the Transmit Frame Sync signal.

- **FSEDGE: Frame Sync Edge Detection**

Determines which edge on frame sync will generate the interrupt TXSYN (Status Register).

Value	Name	Description
0	POSITIVE	Positive Edge Detection
1	NEGATIVE	Negative Edge Detection

- **FSLEN_EXT: FSLEN Field Extension**

Extends FSLEN field. For details, refer to FSLEN bit description on [page 615](#).

30.9.7 SSC Receive Holding Register

Name: SSC_RHR
Address: 0x40004020
Access: Read-only

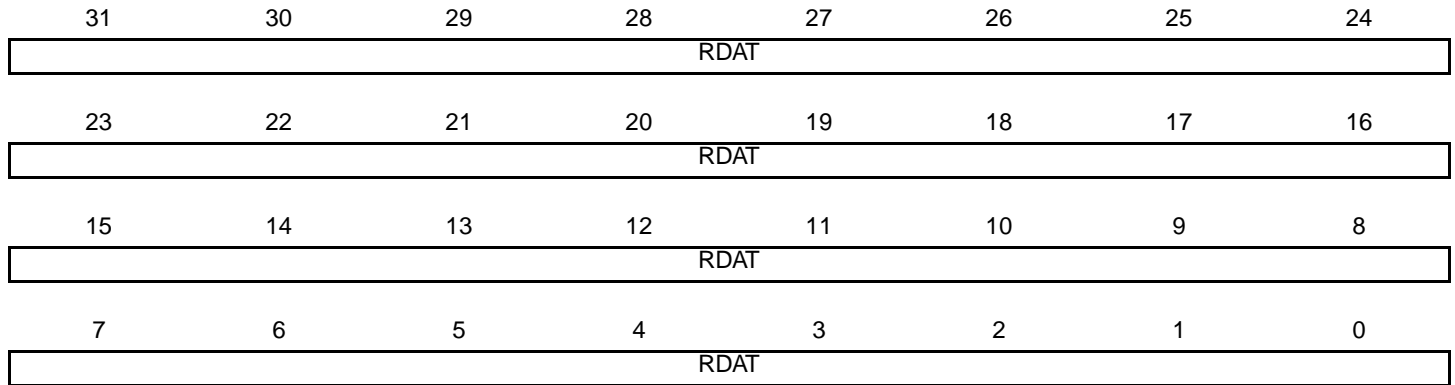

- **RDAT: Receive Data**

Right aligned regardless of the number of data bits defined by DATLEN in SSC_RFMR.

30.9.8 SSC Transmit Holding Register

Name: SSC_THR
Address: 0x40004024
Access: Write-only

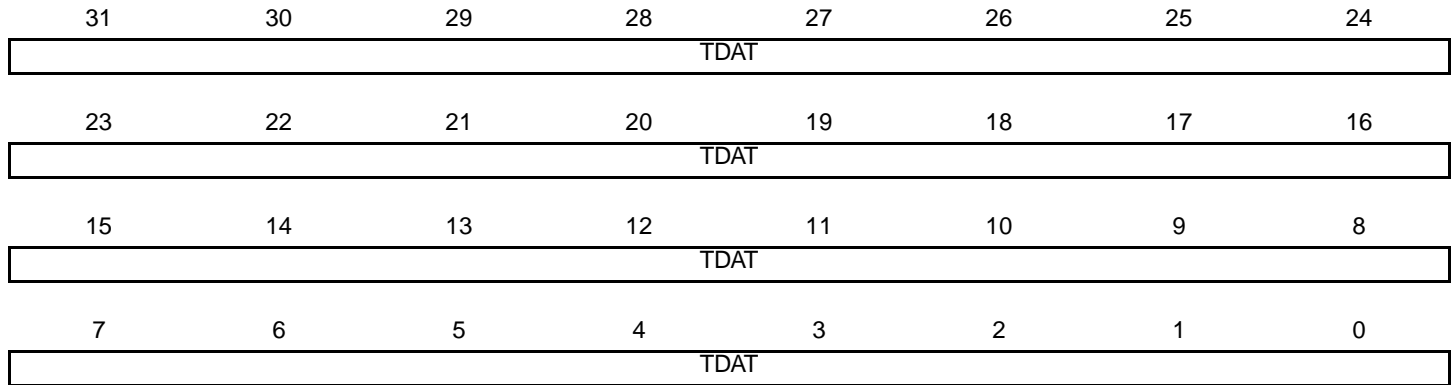

- **TDAT: Transmit Data**

Right aligned regardless of the number of data bits defined by DATLEN in SSC_TFMR.

30.9.9 SSC Receive Synchronization Holding Register

Name: SSC_RSHR

Address: 0x40004030

Access: Read-only

31	30	29	28	27	26	25	24
–	–	–	–	–	–	–	–
23	22	21	20	19	18	17	16
–	–	–	–	–	–	–	–
15	14	13	12	11	10	9	8
RSDAT							
7	6	5	4	3	2	1	0
RSDAT							

- **RSDAT: Receive Synchronization Data**



30.9.10 SSC Transmit Synchronization Holding Register

Name: SSC_TSHR

Address: 0x40004034

Access: Read-write

31	30	29	28	27	26	25	24
-	-	-	-	-	-	-	-
23	22	21	20	19	18	17	16
-	-	-	-	-	-	-	-
15	14	13	12	11	10	9	8
TSDAT							
7	6	5	4	3	2	1	0
TSDAT							

- TSDAT: Transmit Synchronization Data



30.9.11 SSC Receive Compare 0 Register

Name: SSC_RC0R

Address: 0x40004038

Access: Read-write

31	30	29	28	27	26	25	24
–	–	–	–	–	–	–	–
23	22	21	20	19	18	17	16
–	–	–	–	–	–	–	–
15	14	13	12	11	10	9	8
CP0							
7	6	5	4	3	2	1	0
CP0							

This register can only be written if the WPEN bit is cleared in [“SSC Write Protect Mode Register”](#).

- **CP0: Receive Compare Data 0**

30.9.12 SSC Receive Compare 1 Register

Name: SSC_RC1R

Address: 0x4000403C

Access: Read-write

31	30	29	28	27	26	25	24
–	–	–	–	–	–	–	–
23	22	21	20	19	18	17	16
–	–	–	–	–	–	–	–
15	14	13	12	11	10	9	8
CP1							
7	6	5	4	3	2	1	0
CP1							

This register can only be written if the WPEN bit is cleared in [“SSC Write Protect Mode Register”](#).

- **CP1: Receive Compare Data 1**

30.9.13 SSC Status Register

Name: SSC_SR
Address: 0x40004040
Access: Read-only

31	30	29	28	27	26	25	24
–	–	–	–	–	–	–	–
23	22	21	20	19	18	17	16
–	–	–	–	–	–	RXEN	TXEN
15	14	13	12	11	10	9	8
–	–	–	–	RXSYN	TXSYN	CP1	CP0
7	6	5	4	3	2	1	0
RXBUFF	ENDRX	OVRUN	RXRDY	TXBUFE	ENDTX	TXEMPTY	TXRDY

- **TXRDY: Transmit Ready**
 0 = Data has been loaded in SSC_THR and is waiting to be loaded in the Transmit Shift Register (TSR).
 1 = SSC_THR is empty.
- **TXEMPTY: Transmit Empty**
 0 = Data remains in SSC_THR or is currently transmitted from TSR.
 1 = Last data written in SSC_THR has been loaded in TSR and last data loaded in TSR has been transmitted.
- **ENDTX: End of Transmission**
 0 = The register SSC_TCR has not reached 0 since the last write in SSC_TCR or SSC_TNCR.
 1 = The register SSC_TCR has reached 0 since the last write in SSC_TCR or SSC_TNCR.
- **TXBUFE: Transmit Buffer Empty**
 0 = SSC_TCR or SSC_TNCR have a value other than 0.
 1 = Both SSC_TCR and SSC_TNCR have a value of 0.
- **RXRDY: Receive Ready**
 0 = SSC_RHR is empty.
 1 = Data has been received and loaded in SSC_RHR.
- **OVRUN: Receive Overrun**
 0 = No data has been loaded in SSC_RHR while previous data has not been read since the last read of the Status Register.
 1 = Data has been loaded in SSC_RHR while previous data has not yet been read since the last read of the Status Register.
- **ENDRX: End of Reception**
 0 = Data is written on the Receive Counter Register or Receive Next Counter Register.
 1 = End of PDC transfer when Receive Counter Register has arrived at zero.



- **RXBUFF: Receive Buffer Full**

0 = SSC_RCR or SSC_RNCR have a value other than 0.

1 = Both SSC_RCR and SSC_RNCR have a value of 0.

- **CP0: Compare 0**

0 = A compare 0 has not occurred since the last read of the Status Register.

1 = A compare 0 has occurred since the last read of the Status Register.

- **CP1: Compare 1**

0 = A compare 1 has not occurred since the last read of the Status Register.

1 = A compare 1 has occurred since the last read of the Status Register.

- **TXSYN: Transmit Sync**

0 = A Tx Sync has not occurred since the last read of the Status Register.

1 = A Tx Sync has occurred since the last read of the Status Register.

- **RXSYN: Receive Sync**

0 = An Rx Sync has not occurred since the last read of the Status Register.

1 = An Rx Sync has occurred since the last read of the Status Register.

- **TXEN: Transmit Enable**

0 = Transmit is disabled.

1 = Transmit is enabled.

- **RXEN: Receive Enable**

0 = Receive is disabled.

1 = Receive is enabled.

30.9.14 SSC Interrupt Enable Register

Name: SSC_IER
Address: 0x40004044
Access: Write-only

31	30	29	28	27	26	25	24
–	–	–	–	–	–	–	–
23	22	21	20	19	18	17	16
–	–	–	–	–	–	–	–
15	14	13	12	11	10	9	8
–	–	–	–	RXSYN	TXSYN	CP1	CP0
7	6	5	4	3	2	1	0
RXBUFF	ENDRX	OVRUN	RXRDY	TXBUFE	ENDTX	TXEMPTY	TXRDY

- TXRDY: Transmit Ready Interrupt Enable**
 0 = 0 = No effect.
 1 = Enables the Transmit Ready Interrupt.
- TXEMPTY: Transmit Empty Interrupt Enable**
 0 = No effect.
 1 = Enables the Transmit Empty Interrupt.
- ENDTX: End of Transmission Interrupt Enable**
 0 = No effect.
 1 = Enables the End of Transmission Interrupt.
- TXBUFE: Transmit Buffer Empty Interrupt Enable**
 0 = No effect.
 1 = Enables the Transmit Buffer Empty Interrupt.
- RXRDY: Receive Ready Interrupt Enable**
 0 = No effect.
 1 = Enables the Receive Ready Interrupt.
- OVRUN: Receive Overrun Interrupt Enable**
 0 = No effect.
 1 = Enables the Receive Overrun Interrupt.
- ENDRX: End of Reception Interrupt Enable**
 0 = No effect.
 1 = Enables the End of Reception Interrupt.

- **RXBUFF: Receive Buffer Full Interrupt Enable**

0 = No effect.

1 = Enables the Receive Buffer Full Interrupt.

- **CP0: Compare 0 Interrupt Enable**

0 = No effect.

1 = Enables the Compare 0 Interrupt.

- **CP1: Compare 1 Interrupt Enable**

0 = No effect.

1 = Enables the Compare 1 Interrupt.

- **TXSYN: Tx Sync Interrupt Enable**

0 = No effect.

1 = Enables the Tx Sync Interrupt.

- **RXSYN: Rx Sync Interrupt Enable**

0 = No effect.

1 = Enables the Rx Sync Interrupt.

30.9.15 SSC Interrupt Disable Register

Name: SSC_IDR
Address: 0x40004048
Access: Write-only

31	30	29	28	27	26	25	24
–	–	–	–	–	–	–	–
23	22	21	20	19	18	17	16
–	–	–	–	–	–	–	–
15	14	13	12	11	10	9	8
–	–	–	–	RXSYN	TXSYN	CP1	CP0
7	6	5	4	3	2	1	0
RXBUFF	ENDRX	OVRUN	RXRDY	TXBUFE	ENDTX	TXEMPTY	TXRDY

- TXRDY: Transmit Ready Interrupt Disable**
 0 = No effect.
 1 = Disables the Transmit Ready Interrupt.
- TXEMPTY: Transmit Empty Interrupt Disable**
 0 = No effect.
 1 = Disables the Transmit Empty Interrupt.
- ENDTX: End of Transmission Interrupt Disable**
 0 = No effect.
 1 = Disables the End of Transmission Interrupt.
- TXBUFE: Transmit Buffer Empty Interrupt Disable**
 0 = No effect.
 1 = Disables the Transmit Buffer Empty Interrupt.
- RXRDY: Receive Ready Interrupt Disable**
 0 = No effect.
 1 = Disables the Receive Ready Interrupt.
- OVRUN: Receive Overrun Interrupt Disable**
 0 = No effect.
 1 = Disables the Receive Overrun Interrupt.
- ENDRX: End of Reception Interrupt Disable**
 0 = No effect.
 1 = Disables the End of Reception Interrupt.

- **RXBUFF: Receive Buffer Full Interrupt Disable**

0 = No effect.

1 = Disables the Receive Buffer Full Interrupt.

- **CP0: Compare 0 Interrupt Disable**

0 = No effect.

1 = Disables the Compare 0 Interrupt.

- **CP1: Compare 1 Interrupt Disable**

0 = No effect.

1 = Disables the Compare 1 Interrupt.

- **TXSYN: Tx Sync Interrupt Enable**

0 = No effect.

1 = Disables the Tx Sync Interrupt.

- **RXSYN: Rx Sync Interrupt Enable**

0 = No effect.

1 = Disables the Rx Sync Interrupt.

30.9.16 SSC Interrupt Mask Register

Name: SSC_IMR

Address: 0x4000404C

Access: Read-only

31	30	29	28	27	26	25	24
–	–	–	–	–	–	–	–
23	22	21	20	19	18	17	16
–	–	–	–	–	–	–	–
15	14	13	12	11	10	9	8
–	–	–	–	RXSYN	TXSYN	CP1	CP0
7	6	5	4	3	2	1	0
RXBUFF	ENDRX	OVRUN	RXRDY	TXBUFE	ENDTX	TXEMPTY	TXRDY

- **TXRDY: Transmit Ready Interrupt Mask**

0 = The Transmit Ready Interrupt is disabled.

1 = The Transmit Ready Interrupt is enabled.

- **TXEMPTY: Transmit Empty Interrupt Mask**

0 = The Transmit Empty Interrupt is disabled.

1 = The Transmit Empty Interrupt is enabled.

- **ENDTX: End of Transmission Interrupt Mask**

0 = The End of Transmission Interrupt is disabled.

1 = The End of Transmission Interrupt is enabled.

- **TXBUFE: Transmit Buffer Empty Interrupt Mask**

0 = The Transmit Buffer Empty Interrupt is disabled.

1 = The Transmit Buffer Empty Interrupt is enabled.

- **RXRDY: Receive Ready Interrupt Mask**

0 = The Receive Ready Interrupt is disabled.

1 = The Receive Ready Interrupt is enabled.

- **OVRUN: Receive Overrun Interrupt Mask**

0 = The Receive Overrun Interrupt is disabled.

1 = The Receive Overrun Interrupt is enabled.

- **ENDRX: End of Reception Interrupt Mask**

0 = The End of Reception Interrupt is disabled.

1 = The End of Reception Interrupt is enabled.

- **RXBUFF: Receive Buffer Full Interrupt Mask**

0 = The Receive Buffer Full Interrupt is disabled.

1 = The Receive Buffer Full Interrupt is enabled.

- **CP0: Compare 0 Interrupt Mask**

0 = The Compare 0 Interrupt is disabled.

1 = The Compare 0 Interrupt is enabled.

- **CP1: Compare 1 Interrupt Mask**

0 = The Compare 1 Interrupt is disabled.

1 = The Compare 1 Interrupt is enabled.

- **TXSYN: Tx Sync Interrupt Mask**

0 = The Tx Sync Interrupt is disabled.

1 = The Tx Sync Interrupt is enabled.

- **RXSYN: Rx Sync Interrupt Mask**

0 = The Rx Sync Interrupt is disabled.

1 = The Rx Sync Interrupt is enabled.

30.9.17 SSC Write Protect Mode Register

Name: SSC_WPMR

Address: 0x400040E4

Access: Read-write

Reset: See [Table 30-6](#)

31	30	29	28	27	26	25	24
WPKEY							
23	22	21	20	19	18	17	16
WPKEY							
15	14	13	12	11	10	9	8
WPKEY							
7	6	5	4	3	2	1	0
—	—	—	—	—	—	—	WPEN

- **WPEN: Write Protect Enable**

0 = Disables the Write Protect if WPKEY corresponds to 0x535343 (“SSC” in ASCII).

1 = Enables the Write Protect if WPKEY corresponds to 0x535343 (“SSC” in ASCII).

Protects the registers:

- [“SSC Clock Mode Register” on page 608](#)
- [“SSC Receive Clock Mode Register” on page 609](#)
- [“SSC Receive Frame Mode Register” on page 611](#)
- [“SSC Transmit Clock Mode Register” on page 613](#)
- [“SSC Transmit Frame Mode Register” on page 615](#)
- [“SSC Receive Compare 0 Register” on page 621](#)
- [“SSC Receive Compare 1 Register” on page 622](#)

- **WPKEY: Write Protect KEY**

Should be written at value 0x535343 (“SSC” in ASCII). Writing any other value in this field aborts the write operation of the WPEN bit. Always reads as 0.

30.9.18 SSC Write Protect Status Register

Name: SSC_WPSR

Address: 0x400040E8

Access: Read-only

Reset: See [Table 30-6](#)

31	30	29	28	27	26	25	24
—	—	—	—	—	—	—	—
23	22	21	20	19	18	17	16
WPVSR							
15	14	13	12	11	10	9	8
WPVSR							
7	6	5	4	3	2	1	0
—	—	—	—	—	—	—	WPVS

- **WPVS: Write Protect Violation Status**

0 = No Write Protect Violation has occurred since the last read of the SSC_WPSR register.

1 = A Write Protect Violation has occurred since the last read of the SSC_WPSR register. If this violation is an unauthorized attempt to write a protected register, the associated violation is reported into field WPVSR.

- **WPVSR: Write Protect Violation Source**

When WPVS is active, this field indicates the write-protected register (through address offset or code) in which a write access has been attempted.

Note: Reading SSC_WPSR automatically clears all fields.

31. Serial Peripheral Interface (SPI)

31.1 Description

The Serial Peripheral Interface (SPI) circuit is a synchronous serial data link that provides communication with external devices in Master or Slave Mode. It also enables communication between processors if an external processor is connected to the system.

The Serial Peripheral Interface is essentially a shift register that serially transmits data bits to other SPIs. During a data transfer, one SPI system acts as the “master” which controls the data flow, while the other devices act as “slaves” which have data shifted into and out by the master. Different CPUs can take turn being masters (Multiple Master Protocol opposite to Single Master Protocol where one CPU is always the master while all of the others are always slaves) and one master may simultaneously shift data into multiple slaves. However, only one slave may drive its output to write data back to the master at any given time.

A slave device is selected when the master asserts its NSS signal. If multiple slave devices exist, the master generates a separate slave select signal for each slave (NPCS).

The SPI system consists of two data lines and two control lines:

- Master Out Slave In (MOSI): This data line supplies the output data from the master shifted into the input(s) of the slave(s).
- Master In Slave Out (MISO): This data line supplies the output data from a slave to the input of the master. There may be no more than one slave transmitting data during any particular transfer.
- Serial Clock (SPCK): This control line is driven by the master and regulates the flow of the data bits. The master may transmit data at a variety of baud rates; the SPCK line cycles once for each bit that is transmitted.
- Slave Select (NSS): This control line allows slaves to be turned on and off by hardware.

31.2 Embedded Characteristics

- Supports communication with serial external devices
 - Four chip selects with external decoder support allow communication with up to 15 peripherals
 - Serial memories, such as DataFlash®
 - Serial peripherals, such as ADCs, DACs, LCD Controllers, CAN Controllers and Sensors
 - External co-processors
- Master or slave serial peripheral bus interface
 - 8- to 16-bit programmable data length per chip select
 - Programmable phase and polarity per chip select
 - Programmable transfer delays between consecutive transfers and between clock and data per chip select
 - Programmable delay between consecutive transfers
 - Selectable mode fault detection
- Connection to PDC channel capabilities optimizes data transfers
 - One channel for the receiver, one channel for the transmitter
 - Next buffer support

31.3 Block Diagram

Figure 31-1. Block Diagram

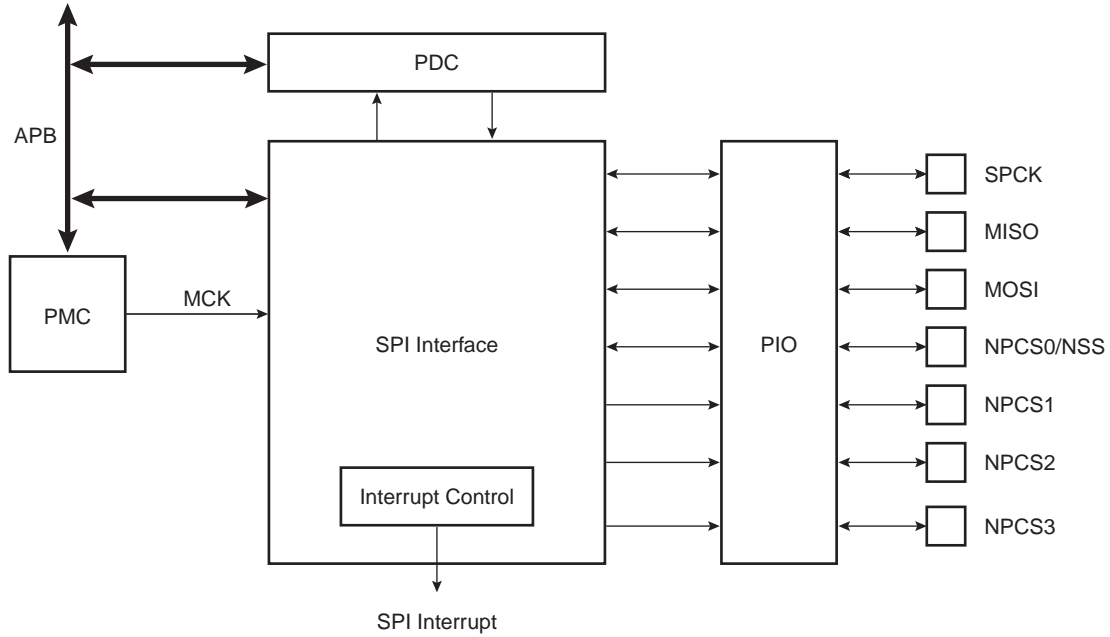

31.4 Application Block Diagram

Figure 31-2. Application Block Diagram: Single Master/Multiple Slave Implementation

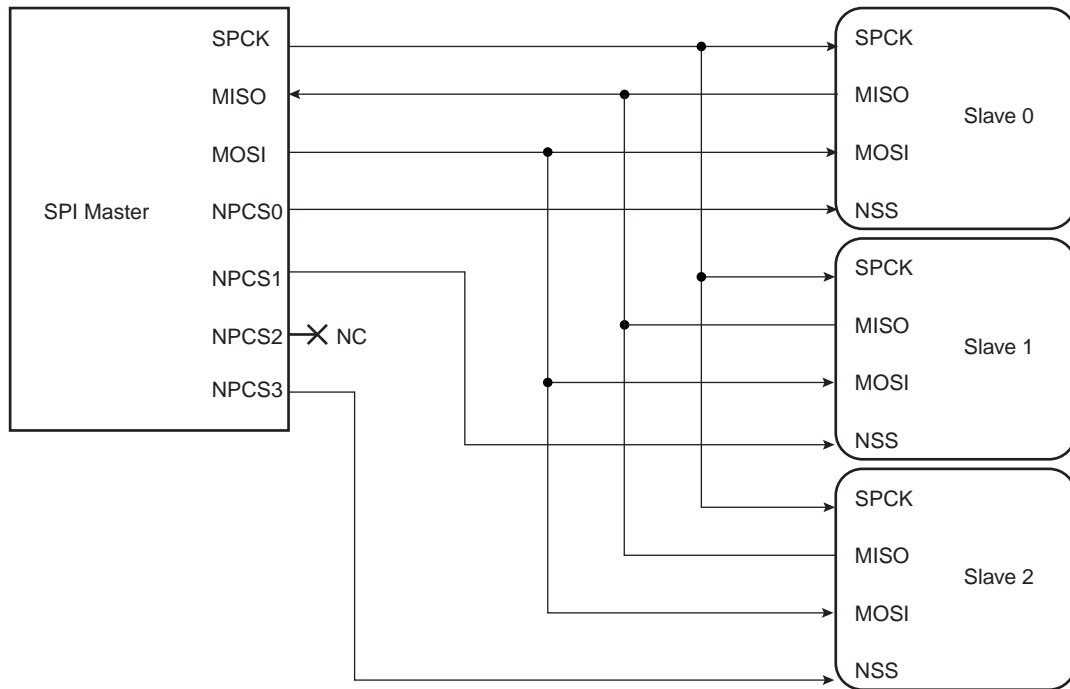

31.5 Signal Description

Signal Description

Pin Name	Pin Description	Type	
		Master	Slave
MISO	Master In Slave Out	Input	Output
MOSI	Master Out Slave In	Output	Input
SPCK	Serial Clock	Output	Input
NPCS1-NPCS3	Peripheral Chip Selects	Output	Unused
NPCS0/NSS	Peripheral Chip Select/Slave Select	Output	Input

31.6 Product Dependencies

31.6.1 I/O Lines

The pins used for interfacing the compliant external devices may be multiplexed with PIO lines. The programmer must first program the PIO controllers to assign the SPI pins to their peripheral functions.

Table 31-1. I/O Lines

Instance	Signal	I/O Line	Peripheral
SPI	MISO	PA12	A
SPI	MOSI	PA13	A
SPI	NPCS0	PA11	A
SPI	NPCS1	PA9	B
SPI	NPCS1	PA31	A
SPI	NPCS1	PB14	A
SPI	NPCS1	PC4	B
SPI	NPCS2	PA10	B
SPI	NPCS2	PA30	B
SPI	NPCS2	PB2	B
SPI	NPCS3	PA3	B
SPI	NPCS3	PA5	B
SPI	NPCS3	PA22	B
SPI	SPCK	PA14	A

31.6.2 Power Management

The SPI may be clocked through the Power Management Controller (PMC), thus the programmer must first configure the PMC to enable the SPI clock.

31.6.3 Interrupt

The SPI interface has an interrupt line connected to the Interrupt Controller. Handling the SPI interrupt requires programming the interrupt controller before configuring the SPI.

Table 31-2. Peripheral IDs

Instance	ID
SPI	21

31.7 Functional Description

31.7.1 Modes of Operation

The SPI operates in Master Mode or in Slave Mode.

Operation in Master Mode is programmed by writing at 1 the MSTR bit in the Mode Register. The pins NPCS0 to NPCS3 are all configured as outputs, the SPCK pin is driven, the MISO line is wired on the receiver input and the MOSI line driven as an output by the transmitter.

If the MSTR bit is written at 0, the SPI operates in Slave Mode. The MISO line is driven by the transmitter output, the MOSI line is wired on the receiver input, the SPCK pin is driven by the transmitter to synchronize the receiver. The NPCS0 pin becomes an input, and is used as a Slave Select signal (NSS). The pins NPCS1 to NPCS3 are not driven and can be used for other purposes.

The data transfers are identically programmable for both modes of operations. The baud rate generator is activated only in Master Mode.

31.7.2 Data Transfer

Four combinations of polarity and phase are available for data transfers. The clock polarity is programmed with the CPOL bit in the Chip Select Register. The clock phase is programmed with the NCPHA bit. These two parameters determine the edges of the clock signal on which data is driven and sampled. Each of the two parameters has two possible states, resulting in four possible combinations that are incompatible with one another. Thus, a master/slave pair must use the same parameter pair values to communicate. If multiple slaves are used and fixed in different configurations, the master must reconfigure itself each time it needs to communicate with a different slave.

[Table 31-3](#) shows the four modes and corresponding parameter settings.

Table 31-3. SPI Bus Protocol Mode

SPI Mode	CPOL	NCPHA	Shift SPCK Edge	Capture SPCK Edge	SPCK Inactive Level
0	0	1	Falling	Rising	Low
1	0	0	Rising	Falling	Low
2	1	1	Rising	Falling	High
3	1	0	Falling	Rising	High

[Figure 31-3](#) and [Figure 31-4](#) show examples of data transfers.

Figure 31-3. SPI Transfer Format (NCPHA = 1, 8 bits per transfer)

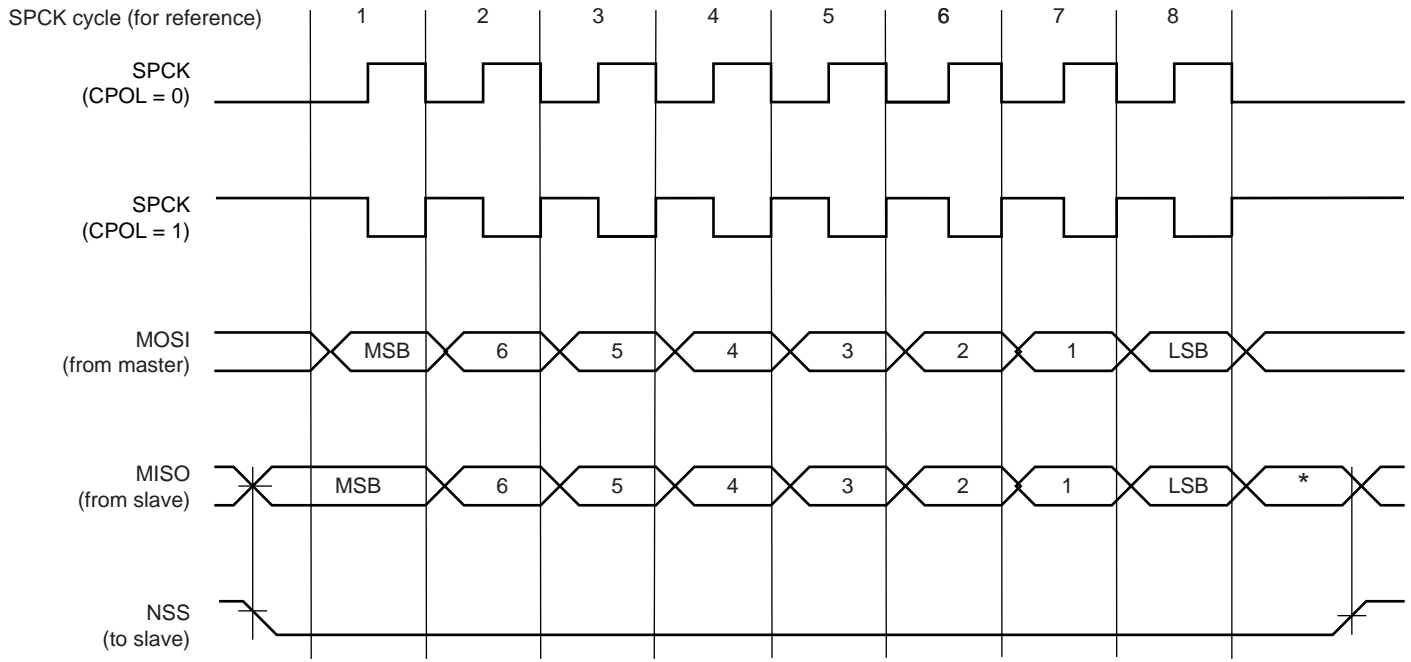

* Not defined, but normally MSB of previous character received.

Figure 31-4. SPI Transfer Format (NCPHA = 0, 8 bits per transfer)

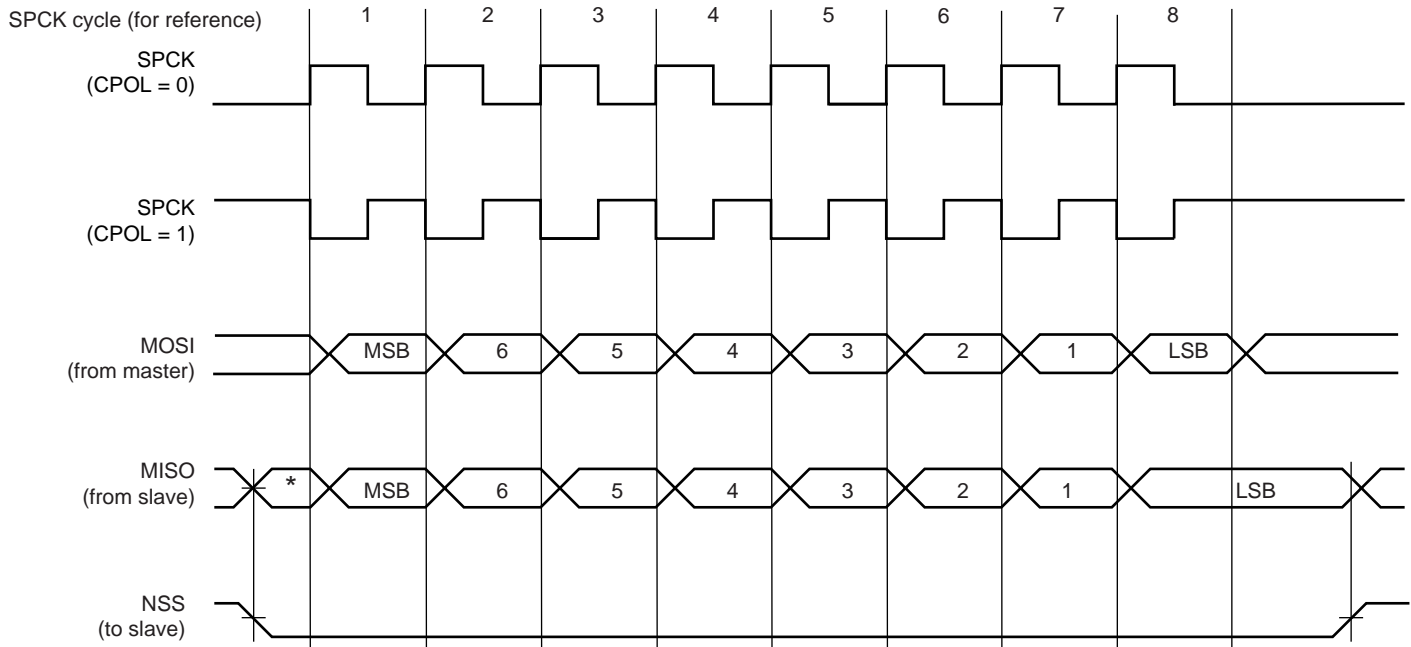

* Not defined but normally LSB of previous character transmitted.

31.7.3 Master Mode Operations

When configured in Master Mode, the SPI operates on the clock generated by the internal programmable baud rate generator. It fully controls the data transfers to and from the slave(s) connected to the SPI bus. The SPI drives the chip select line to the slave and the serial clock signal (SPCK).

The SPI features two holding registers, the Transmit Data Register and the Receive Data Register, and a single Shift Register. The holding registers maintain the data flow at a constant rate.

After enabling the SPI, a data transfer begins when the processor writes to the SPI_TDR (Transmit Data Register). The written data is immediately transferred in the Shift Register and transfer on the SPI bus starts. While the data in the Shift Register is shifted on the MOSI line, the MISO line is sampled and shifted in the Shift Register. Receiving data cannot occur without transmitting data. If receiving mode is not needed, for example when communicating with a slave receiver only (such as an LCD), the receive status flags in the status register can be discarded.

Before writing the TDR, the PCS field in the SPI_MR register must be set in order to select a slave.

After enabling the SPI, a data transfer begins when the processor writes to the SPI_TDR (Transmit Data Register). The written data is immediately transferred in the Shift Register and transfer on the SPI bus starts. While the data in the Shift Register is shifted on the MOSI line, the MISO line is sampled and shifted in the Shift Register. Transmission cannot occur without reception.

Before writing the TDR, the PCS field must be set in order to select a slave.

If new data is written in SPI_TDR during the transfer, it stays in it until the current transfer is completed. Then, the received data is transferred from the Shift Register to SPI_RDR, the data in SPI_TDR is loaded in the Shift Register and a new transfer starts.

The transfer of a data written in SPI_TDR in the Shift Register is indicated by the TDRE bit (Transmit Data Register Empty) in the Status Register (SPI_SR). When new data is written in SPI_TDR, this bit is cleared. The TDRE bit is used to trigger the Transmit PDC channel.

The end of transfer is indicated by the TXEMPTY flag in the SPI_SR register. If a transfer delay (DLYBCT) is greater than 0 for the last transfer, TXEMPTY is set after the completion of said delay. The master clock (MCK) can be switched off at this time.

The transfer of received data from the Shift Register in SPI_RDR is indicated by the RDRF bit (Receive Data Register Full) in the Status Register (SPI_SR). When the received data is read, the RDRF bit is cleared.

If the SPI_RDR (Receive Data Register) has not been read before new data is received, the Overrun Error bit (OVRES) in SPI_SR is set. As long as this flag is set, data is loaded in SPI_RDR. The user has to read the status register to clear the OVRES bit.

[Figure 31-5](#), shows a block diagram of the SPI when operating in Master Mode. [Figure 31-6 on page 641](#) shows a flow chart describing how transfers are handled.

31.7.3.1 Master Mode Block Diagram

Figure 31-5. Master Mode Block Diagram

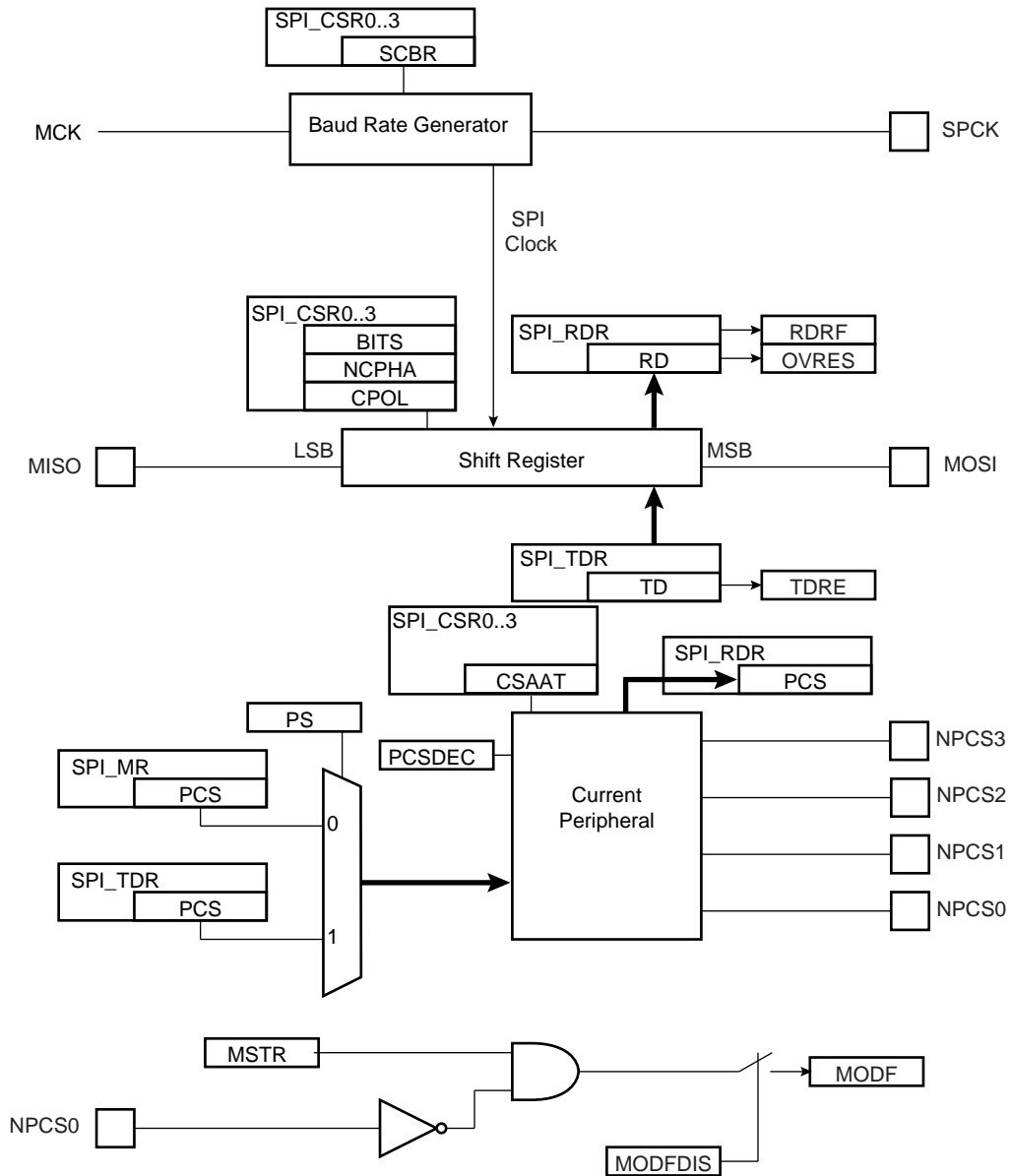

31.7.3.2 Master Mode Flow Diagram

Figure 31-6. Master Mode Flow Diagram

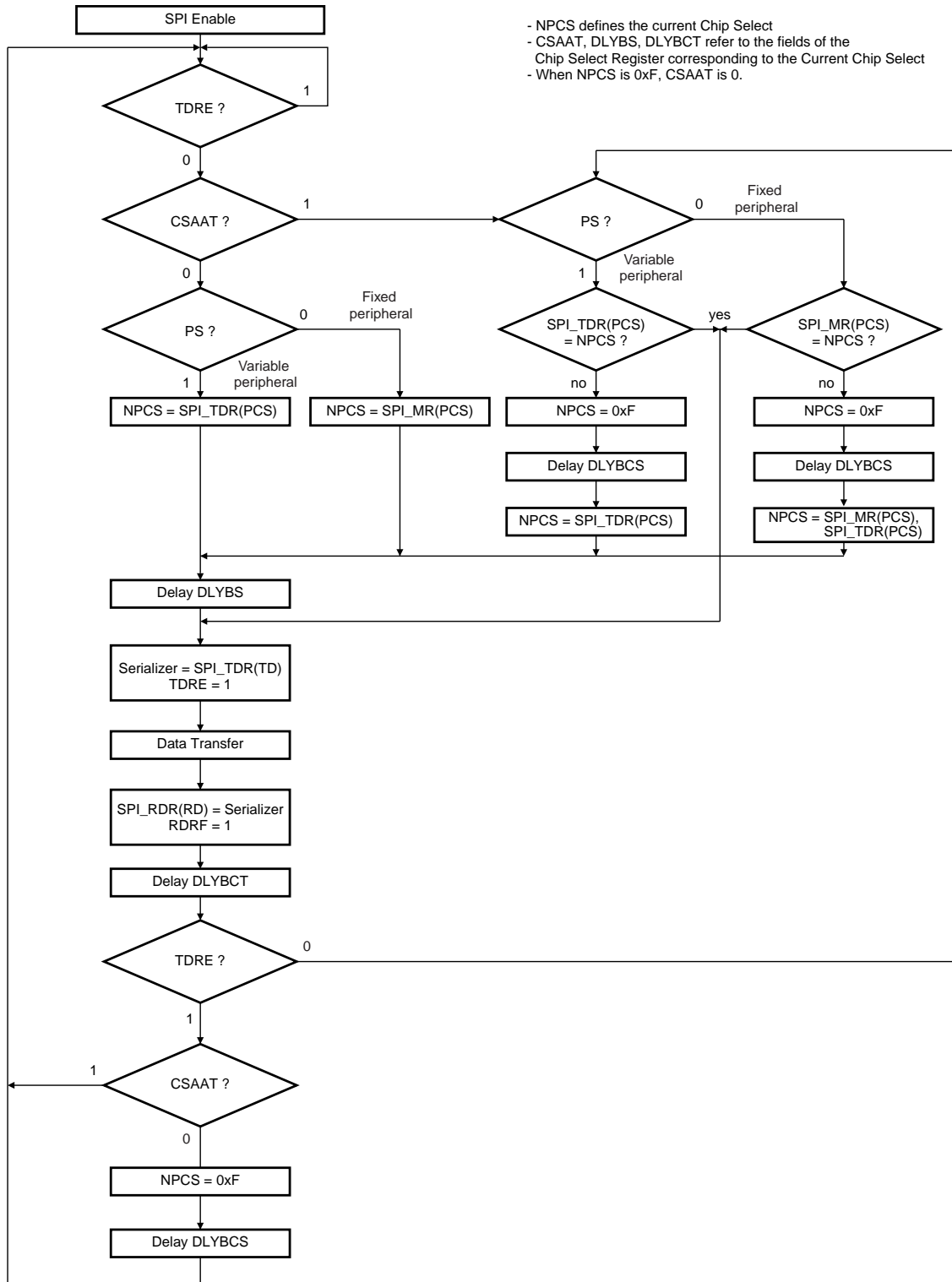

Figure 31-7 shows Transmit Data Register Empty (TDRE), Receive Data Register (RDRF) and Transmission Register Empty (TXEMPTY) status flags behavior within the SPI_SR (Status Register) during an 8-bit data transfer in fixed mode and no Peripheral Data Controller involved.

Figure 31-7. Status Register Flags Behavior

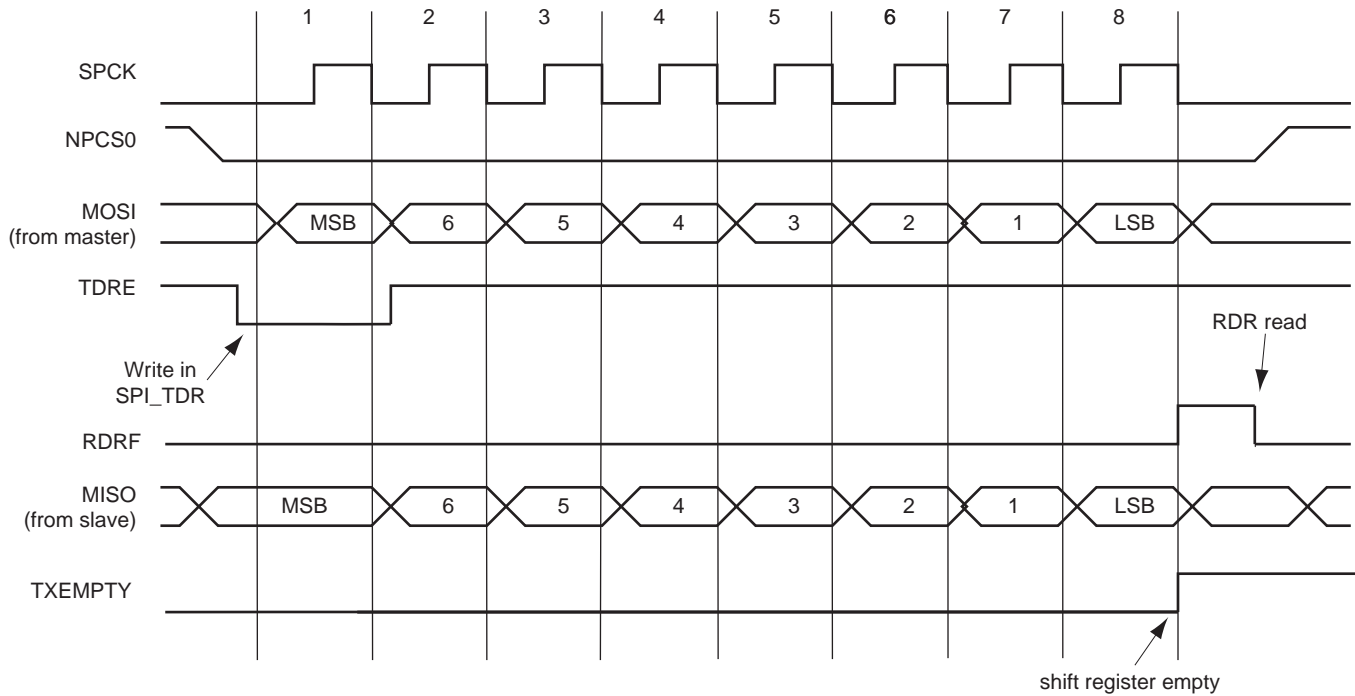
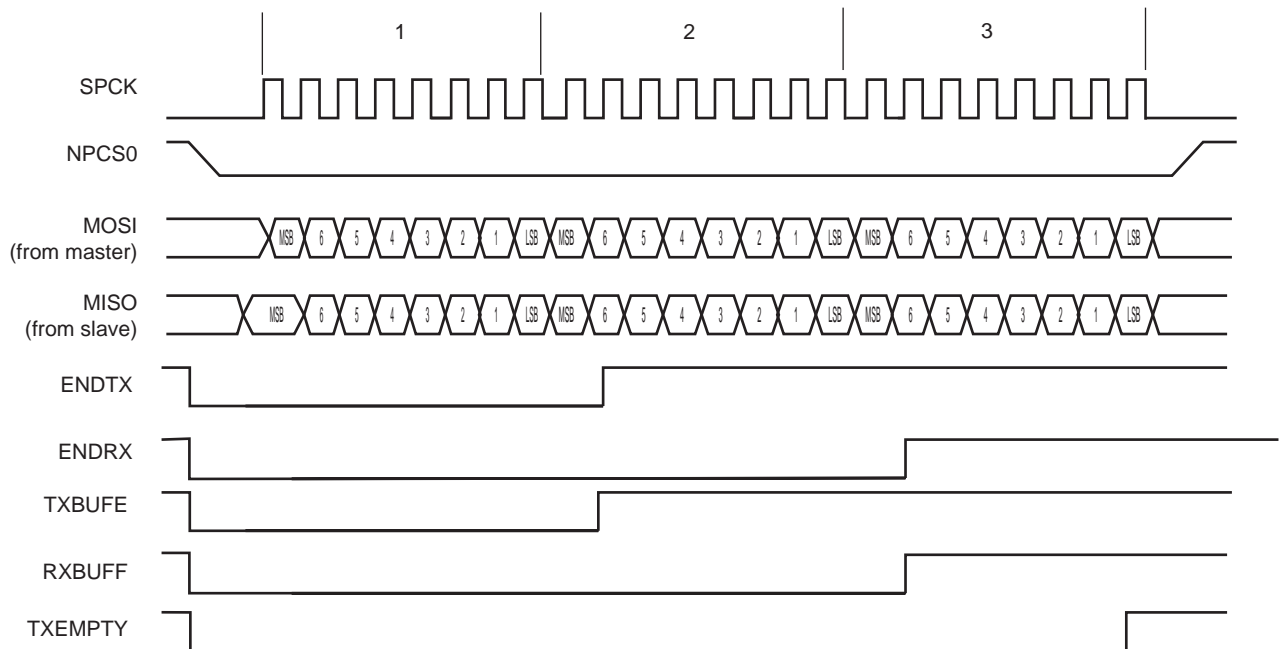

Figure 31-8 shows Transmission Register Empty (TXEMPTY), End of RX buffer (ENDRX), End of TX buffer (ENDTX), RX Buffer Full (RXBUFF) and TX Buffer Empty (TXBUFE) status flags behavior within the SPI_SR (Status Register) during an 8-bit data transfer in fixed mode with the Peripheral Data Controller involved. The PDC is programmed to transfer and receive three data. The next pointer and counter are not used. The RDRF and TDRE are not shown because these flags are managed by the PDC when using the PDC.

Figure 31-8. PDC Status Register Flags Behavior



31.7.3.3 Clock Generation

The SPI Baud rate clock is generated by dividing the Master Clock (MCK), by a value between 1 and 255.

This allows a maximum operating baud rate at up to Master Clock and a minimum operating baud rate of MCK divided by 255.

Programming the SCBR field at 0 is forbidden. Triggering a transfer while SCBR is at 0 can lead to unpredictable results.

At reset, SCBR is 0 and the user has to program it at a valid value before performing the first transfer.

The divisor can be defined independently for each chip select, as it has to be programmed in the SCBR field of the Chip Select Registers. This allows the SPI to automatically adapt the baud rate for each interfaced peripheral without reprogramming.

31.7.3.4 Transfer Delays

Figure 31-9 shows a chip select transfer change and consecutive transfers on the same chip select. Three delays can be programmed to modify the transfer waveforms:

- The delay between chip selects, programmable only once for all the chip selects by writing the DLYBCS field in the Mode Register. Allows insertion of a delay between release of one chip select and before assertion of a new one.
- The delay before SPCK, independently programmable for each chip select by writing the field DLYBS. Allows the start of SPCK to be delayed after the chip select has been asserted.
- The delay between consecutive transfers, independently programmable for each chip select by writing the DLYBCT field. Allows insertion of a delay between two transfers occurring on the same chip select

These delays allow the SPI to be adapted to the interfaced peripherals and their speed and bus release time.

Figure 31-9. Programmable Delays

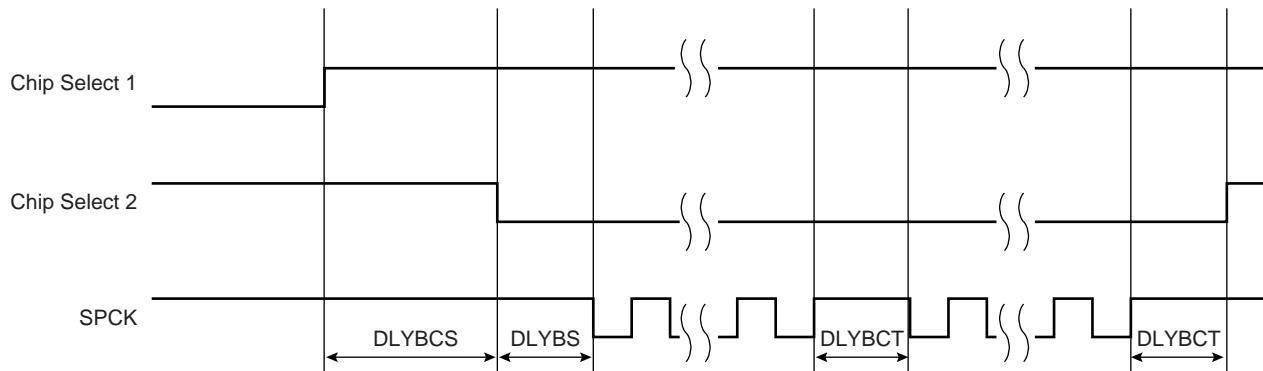

31.7.3.5 Peripheral Selection

The serial peripherals are selected through the assertion of the NPCS0 to NPCS3 signals. By default, all the NPCS signals are high before and after each transfer.

- Fixed Peripheral Select: SPI exchanges data with only one peripheral

Fixed Peripheral Select is activated by writing the PS bit to zero in SPI_MR (Mode Register). In this case, the current peripheral is defined by the PCS field in SPI_MR and the PCS field in the SPI_TDR has no effect.

- Variable Peripheral Select: Data can be exchanged with more than one peripheral without having to reprogram the NPCS field in the SPI_MR register.

Variable Peripheral Select is activated by setting PS bit to one. The PCS field in SPI_TDR is used to select the current peripheral. This means that the peripheral selection can be defined for each new data. The value to write in the SPI_TDR register as the following format.

[xxxxxxx(7-bit) + LASTXFER(1-bit)⁽¹⁾ + xxxx(4-bit) + PCS (4-bit) + DATA (8 to 16-bit)] with PCS equals to the chip select to assert as defined in [Section 31.8.4](#) (SPI Transmit Data Register) and LASTXFER bit at 0 or 1 depending on CSAAT bit.

Note: 1. Optional.

CSAAT, LASTXFER and CSNAAT bits are discussed in [Section 31.7.3.9 "Peripheral Deselection with PDC"](#).

If LASTXFER is used, the command must be issued before writing the last character. Instead of LASTXFER, the user can use the SPIDIS command. After the end of the PDC transfer, wait for the TXEMPTY flag, then write SPIDIS into the SPI_CR register (this will not change the configuration register values); the NPCS will be deactivated after the last character transfer. Then, another PDC transfer can be started if the SPIEN was previously written in the SPI_CR register.

31.7.3.6 SPI Peripheral DMA Controller (PDC)

In both fixed and variable mode the Peripheral DMA Controller (PDC) can be used to reduce processor overhead.

The Fixed Peripheral Selection allows buffer transfers with a single peripheral. Using the PDC is an optimal means, as the size of the data transfer between the memory and the SPI is either

8 bits or 16 bits. However, changing the peripheral selection requires the Mode Register to be reprogrammed.

The Variable Peripheral Selection allows buffer transfers with multiple peripherals without reprogramming the Mode Register. Data written in SPI_TDR is 32 bits wide and defines the real data to be transmitted and the peripheral it is destined to. Using the PDC in this mode requires 32-bit wide buffers, with the data in the LSBs and the PCS and LASTXFER fields in the MSBs, however the SPI still controls the number of bits (8 to 16) to be transferred through MISO and MOSI lines with the chip select configuration registers. This is not the optimal means in term of memory size for the buffers, but it provides a very effective means to exchange data with several peripherals without any intervention of the processor.

Transfer Size

Depending on the data size to transmit, from 8 to 16 bits, the PDC manages automatically the type of pointer's size it has to point to. The PDC will perform the following transfer size depending on the mode and number of bits per data.

Fixed Mode:

- 8-bit Data:
Byte transfer,
PDC Pointer Address = Address + 1 byte,
PDC Counter = Counter - 1
- 8-bit to 16-bit Data:
2 bytes transfer. n-bit data transfer with don't care data (MSB) filled with 0's,
PDC Pointer Address = Address + 2 bytes,
PDC Counter = Counter - 1

Variable Mode:

In variable Mode, PDC Pointer Address = Address + 4 bytes and PDC Counter = Counter - 1 for 8 to 16-bit transfer size. When using the PDC, the TDRE and RDRF flags are handled by the PDC, thus the user's application does not have to check those bits. Only End of RX Buffer (ENDRX), End of TX Buffer (ENDTX), Buffer Full (RXBUFF), TX Buffer Empty (TXBUFE) are significant. For further details about the Peripheral DMA Controller and user interface, refer to the PDC section of the product datasheet.

31.7.3.7 Peripheral Chip Select Decoding

The user can program the SPI to operate with up to 15 peripherals by decoding the four Chip Select lines, NPCS0 to NPCS3 with 1 of up to 16 decoder/demultiplexer. This can be enabled by writing the PCSDEC bit at 1 in the Mode Register (SPI_MR).

When operating without decoding, the SPI makes sure that in any case only one chip select line is activated, i.e., one NPCS line driven low at a time. If two bits are defined low in a PCS field, only the lowest numbered chip select is driven low.

When operating with decoding, the SPI directly outputs the value defined by the PCS field on NPCS lines of either the Mode Register or the Transmit Data Register (depending on PS).

As the SPI sets a default value of 0xF on the chip select lines (i.e. all chip select lines at 1) when not processing any transfer, only 15 peripherals can be decoded.

The SPI has only four Chip Select Registers, not 15. As a result, when decoding is activated, each chip select defines the characteristics of up to four peripherals. As an example, SPI_CRSD0 defines the characteristics of the externally decoded peripherals 0 to 3, corresponding to the

PCS values 0x0 to 0x3. Thus, the user has to make sure to connect compatible peripherals on the decoded chip select lines 0 to 3, 4 to 7, 8 to 11 and 12 to 14. [Figure 31-10](#) below shows such an implementation.

If the CSAAT bit is used, with or without the PDC, the Mode Fault detection for NPCS0 line must be disabled. This is not needed for all other chip select lines since Mode Fault Detection is only on NPCS0.

Figure 31-10. Chip Select Decoding Application Block Diagram: Single Master/Multiple Slave Implementation

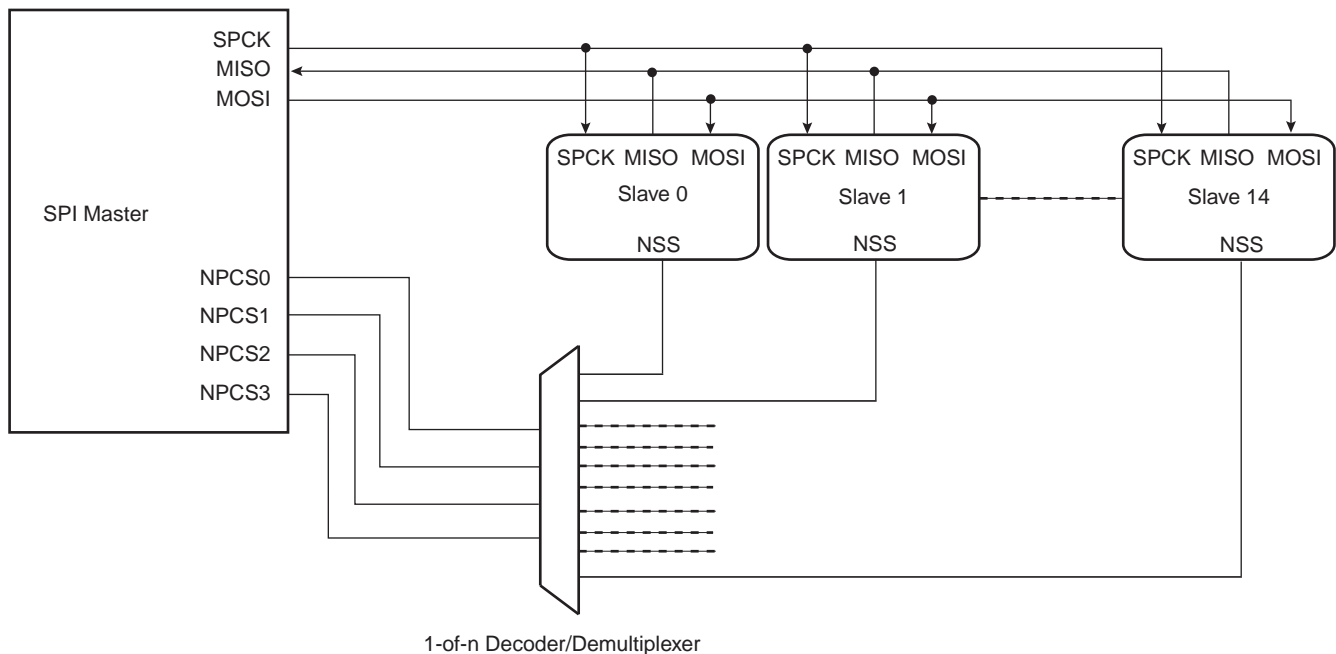

31.7.3.8 Peripheral Deselection without PDC

During a transfer of more than one data on a Chip Select without the PDC, the SPI_TDR is loaded by the processor, the flag TDRE rises as soon as the content of the SPI_TDR is transferred into the internal shift register. When this flag is detected high, the SPI_TDR can be reloaded. If this reload by the processor occurs before the end of the current transfer and if the next transfer is performed on the same chip select as the current transfer, the Chip Select is not de-asserted between the two transfers. But depending on the application software handling the SPI status register flags (by interrupt or polling method) or servicing other interrupts or other tasks, the processor may not reload the SPI_TDR in time to keep the chip select active (low). A null Delay Between Consecutive Transfer (DLYBCT) value in the SPI_CSR register, will give even less time for the processor to reload the SPI_TDR. With some SPI slave peripherals, requiring the chip select line to remain active (low) during a full set of transfers might lead to communication errors.

To facilitate interfacing with such devices, the Chip Select Register [CSR0...CSR3] can be programmed with the CSAAT bit (Chip Select Active After Transfer) at 1. This allows the chip select lines to remain in their current state (low = active) until transfer to another chip select is required. Even if the SPI_TDR is not reloaded the chip select will remain active. To have the chip select line to raise at the end of the transfer the Last transfer Bit (LASTXFER) in the SPI_MR register must be set at 1 before writing the last data to transmit into the SPI_TDR.

31.7.3.9 Peripheral Deselection with PDC

When the Peripheral DMA Controller is used, the chip select line will remain low during the whole transfer since the TDRE flag is managed by the PDC itself. The reloading of the SPI_TDR by the PDC is done as soon as TDRE flag is set to one. In this case the use of CSAAT bit might not be needed. However, it may happen that when other PDC channels connected to other peripherals are in use as well, the SPI PDC might be delayed by another (PDC with a higher priority on the bus). Having PDC buffers in slower memories like flash memory or SDRAM compared to fast internal SRAM, may lengthen the reload time of the SPI_TDR by the PDC as well. This means that the SPI_TDR might not be reloaded in time to keep the chip select line low. In this case the chip select line may toggle between data transfer and according to some SPI Slave devices, the communication might get lost. The use of the CSAAT bit might be needed.

When the CSAAT bit is set at 0, the NPCS does not rise in all cases between two transfers on the same peripheral. During a transfer on a Chip Select, the flag TDRE rises as soon as the content of the SPI_TDR is transferred into the internal shifter. When this flag is detected the SPI_TDR can be reloaded. If this reload occurs before the end of the current transfer and if the next transfer is performed on the same chip select as the current transfer, the Chip Select is not de-asserted between the two transfers. This might lead to difficulties for interfacing with some serial peripherals requiring the chip select to be de-asserted after each transfer. To facilitate interfacing with such devices, the Chip Select Register can be programmed with the CSNAAT bit (Chip Select Not Active After Transfer) at 1. This allows to de-assert systematically the chip select lines during a time DLYBCS. (The value of the CSNAAT bit is taken into account only if the CSAAT bit is set at 0 for the same Chip Select).

[Figure 31-11](#) shows different peripheral deselection cases and the effect of the CSAAT and CSNAAT bits.

Figure 31-11. Peripheral Deselection

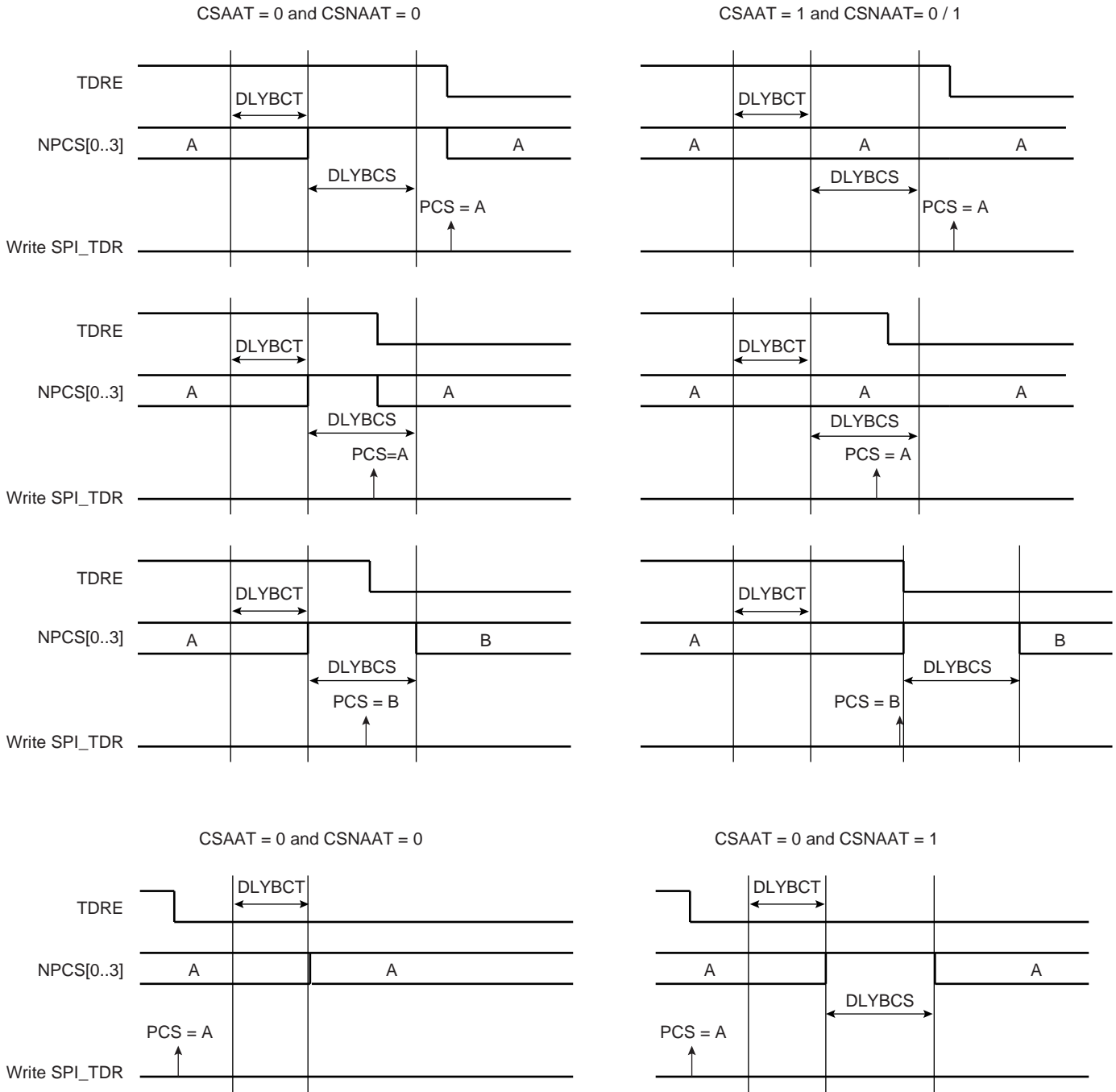

31.7.3.10 Mode Fault Detection

A mode fault is detected when the SPI is programmed in Master Mode and a low level is driven by an external master on the NPCS0/NSS signal. In this case, multi-master configuration, NPCS0, MOSI, MISO and SPCK pins must be configured in open drain (through the PIO controller). When a mode fault is detected, the MODF bit in the SPI_SR is set until the SPI_SR is read and the SPI is automatically disabled until re-enabled by writing the SPIEN bit in the SPI_CR (Control Register) at 1.

By default, the Mode Fault detection circuitry is enabled. The user can disable Mode Fault detection by setting the MODFDIS bit in the SPI Mode Register (SPI_MR).

31.7.4 SPI Slave Mode

When operating in Slave Mode, the SPI processes data bits on the clock provided on the SPI clock pin (SPCK).

The SPI waits for NSS to go active before receiving the serial clock from an external master. When NSS falls, the clock is validated on the serializer, which processes the number of bits defined by the BITS field of the Chip Select Register 0 (SPI_CSR0). These bits are processed following a phase and a polarity defined respectively by the NCPHA and CPOL bits of the SPI_CSR0. Note that BITS, CPOL and NCPHA of the other Chip Select Registers have no effect when the SPI is programmed in Slave Mode.

The bits are shifted out on the MISO line and sampled on the MOSI line.

(For more information on BITS field, see also, the [\(Note:\)](#) below the register table; [Section 31.8.9 “SPI Chip Select Register”](#) on page 662.)

When all the bits are processed, the received data is transferred in the Receive Data Register and the RDRF bit rises. If the SPI_RDR (Receive Data Register) has not been read before new data is received, the Overrun Error bit (OVRES) in SPI_SR is set. As long as this flag is set, data is loaded in SPI_RDR. The user has to read the status register to clear the OVRES bit.

When a transfer starts, the data shifted out is the data present in the Shift Register. If no data has been written in the Transmit Data Register (SPI_TDR), the last data received is transferred. If no data has been received since the last reset, all bits are transmitted low, as the Shift Register resets at 0.

When a first data is written in SPI_TDR, it is transferred immediately in the Shift Register and the TDRE bit rises. If new data is written, it remains in SPI_TDR until a transfer occurs, i.e. NSS falls and there is a valid clock on the SPCK pin. When the transfer occurs, the last data written in SPI_TDR is transferred in the Shift Register and the TDRE bit rises. This enables frequent updates of critical variables with single transfers.

Then, a new data is loaded in the Shift Register from the Transmit Data Register. In case no character is ready to be transmitted, i.e. no character has been written in SPI_TDR since the last load from SPI_TDR to the Shift Register, the Shift Register is not modified and the last received character is retransmitted. In this case the Underrun Error Status Flag (UNDES) is set in the SPI_SR.

Figure 31-12 shows a block diagram of the SPI when operating in Slave Mode.

Figure 31-12. Slave Mode Functional Bloc Diagram

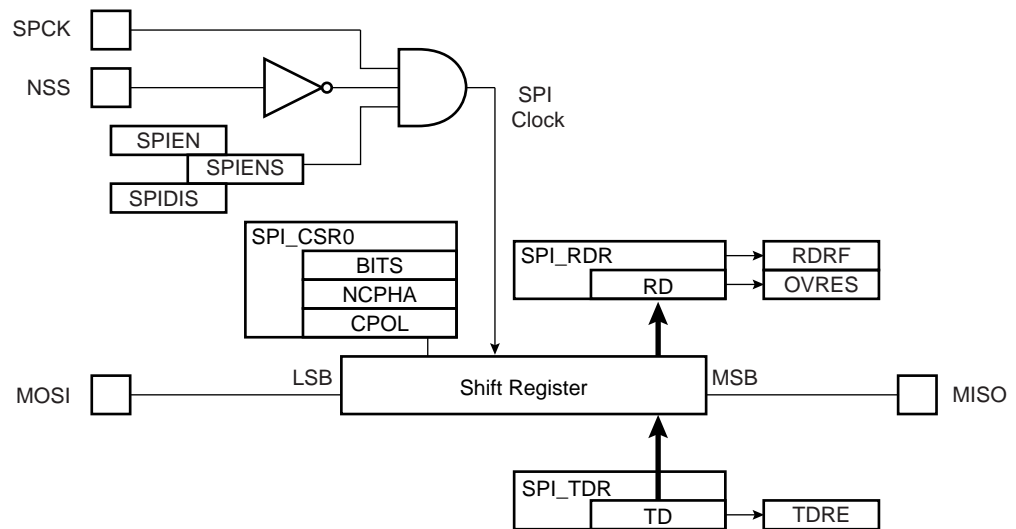

31.7.5 Write Protected Registers

To prevent any single software error that may corrupt SPI behavior, the registers listed below can be write-protected by setting the WPEN bit in the SPI Write Protection Mode Register (SPI_WPMR).

If a write access in a write-protected register is detected, then the WPVS flag in the SPI Write Protection Status Register (SPI_WPSR) is set and the field WPVSR indicates in which register the write access has been attempted.

The WPVS flag is automatically reset after reading the SPI Write Protection Status Register (SPI_WPSR).

List of the write-protected registers:

[Section 31.8.2 "SPI Mode Register"](#)

[Section 31.8.9 "SPI Chip Select Register"](#)

31.8 Serial Peripheral Interface (SPI) User Interface

Table 31-4. Register Mapping

Offset	Register	Name	Access	Reset
0x00	Control Register	SPI_CR	Write-only	---
0x04	Mode Register	SPI_MR	Read-write	0x0
0x08	Receive Data Register	SPI_RDR	Read-only	0x0
0x0C	Transmit Data Register	SPI_TDR	Write-only	---
0x10	Status Register	SPI_SR	Read-only	0x000000F0
0x14	Interrupt Enable Register	SPI_IER	Write-only	---
0x18	Interrupt Disable Register	SPI_IDR	Write-only	---
0x1C	Interrupt Mask Register	SPI_IMR	Read-only	0x0
0x20 - 0x2C	Reserved			
0x30	Chip Select Register 0	SPI_CSR0	Read-write	0x0
0x34	Chip Select Register 1	SPI_CSR1	Read-write	0x0
0x38	Chip Select Register 2	SPI_CSR2	Read-write	0x0
0x3C	Chip Select Register 3	SPI_CSR3	Read-write	0x0
0x4C - 0xE0	Reserved	–	–	–
0xE4	Write Protection Control Register	SPI_WPMR	Read-write	0x0
0xE8	Write Protection Status Register	SPI_WPSR	Read-only	0x0
0x00E8 - 0x00F8	Reserved	–	–	–
0x00FC	Reserved	–	–	–
0x100 - 0x124	Reserved for PDC Registers	–	–	–

31.8.1 SPI Control Register

Name: SPI_CR
Address: 0x40008000
Access: Write-only

31	30	29	28	27	26	25	24
–	–	–	–	–	–	–	LASTXFER
23	22	21	20	19	18	17	16
–	–	–	–	–	–	–	–
15	14	13	12	11	10	9	8
–	–	–	–	–	–	–	–
7	6	5	4	3	2	1	0
SWRST	–	–	–	–	–	SPIDIS	SPIEN

- **SPIEN: SPI Enable**

0 = No effect.

1 = Enables the SPI to transfer and receive data.

- **SPIDIS: SPI Disable**

0 = No effect.

1 = Disables the SPI.

As soon as SPIDIS is set, SPI finishes its transfer.

All pins are set in input mode and no data is received or transmitted.

If a transfer is in progress, the transfer is finished before the SPI is disabled.

If both SPIEN and SPIDIS are equal to one when the control register is written, the SPI is disabled.

- **SWRST: SPI Software Reset**

0 = No effect.

1 = Reset the SPI. A software-triggered hardware reset of the SPI interface is performed.

The SPI is in slave mode after software reset.

PDC channels are not affected by software reset.

- **LASTXFER: Last Transfer**

0 = No effect.

1 = The current NPCS will be deasserted after the character written in TD has been transferred. When CSAAT is set, this allows to close the communication with the current serial peripheral by raising the corresponding NPCS line as soon as TD transfer has completed.

Refer to [Section 31.7.3.5 "Peripheral Selection"](#) for more details.

31.8.2 SPI Mode Register

Name: SPI_MR
Address: 0x40008004
Access: Read-write

31	30	29	28	27	26	25	24
DLYBCS							
23	22	21	20	19	18	17	16
-				PCS			
15	14	13	12	11	10	9	8
-							
7	6	5	4	3	2	1	0
LLB	-	WDRBT	MODFDIS	-	PCSDEC	PS	MSTR

This register can only be written if the WPEN bit is cleared in "SPI Write Protection Mode Register".

- **MSTR: Master/Slave Mode**

0 = SPI is in Slave mode.

1 = SPI is in Master mode.

- **PS: Peripheral Select**

0 = Fixed Peripheral Select.

1 = Variable Peripheral Select.

- **PCSDEC: Chip Select Decode**

0 = The chip selects are directly connected to a peripheral device.

1 = The four chip select lines are connected to a 4- to 16-bit decoder.

When PCSDEC equals one, up to 15 Chip Select signals can be generated with the four lines using an external 4- to 16-bit decoder. The Chip Select Registers define the characteristics of the 15 chip selects according to the following rules:

SPI_CSR0 defines peripheral chip select signals 0 to 3.

SPI_CSR1 defines peripheral chip select signals 4 to 7.

SPI_CSR2 defines peripheral chip select signals 8 to 11.

SPI_CSR3 defines peripheral chip select signals 12 to 14.

- **MODFDIS: Mode Fault Detection**

0 = Mode fault detection is enabled.

1 = Mode fault detection is disabled.

- **WDRBT: Wait Data Read Before Transfer**

0 = No Effect. In master mode, a transfer can be initiated whatever the state of the Receive Data Register is.

1 = In Master Mode, a transfer can start only if the Receive Data Register is empty, i.e. does not contain any unread data. This mode prevents overrun error in reception.

- **LLB: Local Loopback Enable**

0 = Local loopback path disabled.

1 = Local loopback path enabled

LLB controls the local loopback on the data serializer for testing in Master Mode only. (MISO is internally connected on MOSI.)

- **PCS: Peripheral Chip Select**

This field is only used if Fixed Peripheral Select is active (PS = 0).

If PCSDEC = 0:

PCS = xxx0 NPCS[3:0] = 1110

PCS = xx01 NPCS[3:0] = 1101

PCS = x011 NPCS[3:0] = 1011

PCS = 0111 NPCS[3:0] = 0111

PCS = 1111 forbidden (no peripheral is selected)

(x = don't care)

If PCSDEC = 1:

NPCS[3:0] output signals = PCS.

- **DLYBCS: Delay Between Chip Selects**

This field defines the delay from NPCS inactive to the activation of another NPCS. The DLYBCS time guarantees non-overlapping chip selects and solves bus contentions in case of peripherals having long data float times.

If DLYBCS is less than or equal to six, six MCK periods will be inserted by default.

Otherwise, the following equation determines the delay:

$$\text{Delay Between Chip Selects} = \frac{DLYBCS}{MCK}$$

31.8.3 SPI Receive Data Register

Name: SPI_RDR
Address: 0x40008008
Access: Read-only

31	30	29	28	27	26	25	24
–	–	–	–	–	–	–	–
23	22	21	20	19	18	17	16
–	–	–	–	PCS			
15	14	13	12	11	10	9	8
RD							
7	6	5	4	3	2	1	0
RD							

- **RD: Receive Data**

Data received by the SPI Interface is stored in this register right-justified. Unused bits read zero.

- **PCS: Peripheral Chip Select**

In Master Mode only, these bits indicate the value on the NPCS pins at the end of a transfer. Otherwise, these bits read zero.

Note: When using variable peripheral select mode (PS = 1 in SPI_MR) it is mandatory to also set the WDRBT field to 1 if the SPI_RDR PCS field is to be processed.

31.8.4 SPI Transmit Data Register

Name: SPI_TDR
Address: 0x4000800C
Access: Write-only

31	30	29	28	27	26	25	24
–	–	–	–	–	–	–	LASTXFER
23	22	21	20	19	18	17	16
–	–	–	–	PCS			
15	14	13	12	11	10	9	8
TD							
7	6	5	4	3	2	1	0
TD							

- **TD: Transmit Data**

Data to be transmitted by the SPI Interface is stored in this register. Information to be transmitted must be written to the transmit data register in a right-justified format.

- **PCS: Peripheral Chip Select**

This field is only used if Variable Peripheral Select is active (PS = 1).

If PCSDEC = 0:

- PCS = xxx0 NPCS[3:0] = 1110
 - PCS = xx01 NPCS[3:0] = 1101
 - PCS = x011 NPCS[3:0] = 1011
 - PCS = 0111 NPCS[3:0] = 0111
 - PCS = 1111 forbidden (no peripheral is selected)
- (x = don't care)

If PCSDEC = 1:

NPCS[3:0] output signals = PCS

- **LASTXFER: Last Transfer**

0 = No effect.

1 = The current NPCS will be deasserted after the character written in TD has been transferred. When CSAAT is set, this allows to close the communication with the current serial peripheral by raising the corresponding NPCS line as soon as TD transfer has completed.

This field is only used if Variable Peripheral Select is active (PS = 1).

31.8.5 SPI Status Register

Name: SPI_SR
Address: 0x40008010
Access: Read-only

31	30	29	28	27	26	25	24
–	–	–	–	–	–	–	–
23	22	21	20	19	18	17	16
–	–	–	–	–	–	–	SPIENS
15	14	13	12	11	10	9	8
–	–	–	–	–	UNDES	TXEMPTY	NSSR
7	6	5	4	3	2	1	0
TXBUFE	RXBUFF	ENDTX	ENDRX	OVRES	MODF	TDRE	RDRF

- **RDRF: Receive Data Register Full**

0 = No data has been received since the last read of SPI_RDR

1 = Data has been received and the received data has been transferred from the serializer to SPI_RDR since the last read of SPI_RDR.

- **TDRE: Transmit Data Register Empty**

0 = Data has been written to SPI_TDR and not yet transferred to the serializer.

1 = The last data written in the Transmit Data Register has been transferred to the serializer.

TDRE equals zero when the SPI is disabled or at reset. The SPI enable command sets this bit to one.

- **MODF: Mode Fault Error**

0 = No Mode Fault has been detected since the last read of SPI_SR.

1 = A Mode Fault occurred since the last read of the SPI_SR.

- **OVRES: Overrun Error Status**

0 = No overrun has been detected since the last read of SPI_SR.

1 = An overrun has occurred since the last read of SPI_SR.

An overrun occurs when SPI_RDR is loaded at least twice from the serializer since the last read of the SPI_RDR.

- **ENDRX: End of RX buffer**

0 = The Receive Counter Register has not reached 0 since the last write in SPI_RCR⁽¹⁾ or SPI_RNCR⁽¹⁾.

1 = The Receive Counter Register has reached 0 since the last write in SPI_RCR⁽¹⁾ or SPI_RNCR⁽¹⁾.

- **ENDTX: End of TX buffer**

0 = The Transmit Counter Register has not reached 0 since the last write in SPI_TCR⁽¹⁾ or SPI_TNCR⁽¹⁾.

1 = The Transmit Counter Register has reached 0 since the last write in SPI_TCR⁽¹⁾ or SPI_TNCR⁽¹⁾.

- **RXBUFF: RX Buffer Full**

0 = SPI_RCR⁽¹⁾ or SPI_RNCR⁽¹⁾ has a value other than 0.

1 = Both SPI_RCR⁽¹⁾ and SPI_RNCR⁽¹⁾ have a value of 0.

- **TXBUFE: TX Buffer Empty**

0 = SPI_TCR⁽¹⁾ or SPI_TNCR⁽¹⁾ has a value other than 0.

1 = Both SPI_TCR⁽¹⁾ and SPI_TNCR⁽¹⁾ have a value of 0.

- **NSSR: NSS Rising**

0 = No rising edge detected on NSS pin since last read.

1 = A rising edge occurred on NSS pin since last read.

- **TXEMPTY: Transmission Registers Empty**

0 = As soon as data is written in SPI_TDR.

1 = SPI_TDR and internal shifter are empty. If a transfer delay has been defined, TXEMPTY is set after the completion of such delay.

- **UNDES: Underrun Error Status (Slave Mode Only)**

0 = No underrun has been detected since the last read of SPI_SR.

1 = A transfer begins whereas no data has been loaded in the Transmit Data Register.

- **SPIENS: SPI Enable Status**

0 = SPI is disabled.

1 = SPI is enabled.

Note: 1. SPI_RCR, SPI_RNCR, SPI_TCR, SPI_TNCR are physically located in the PDC.

31.8.6 SPI Interrupt Enable Register

Name: SPI_IER
Address: 0x40008014
Access: Write-only

31	30	29	28	27	26	25	24
–	–	–	–	–	–	–	–
23	22	21	20	19	18	17	16
–	–	–	–	–	–	–	–
15	14	13	12	11	10	9	8
–	–	–	–	–	UNDES	TXEMPTY	NSSR
7	6	5	4	3	2	1	0
TXBUFE	RXBUFF	ENDTX	ENDRX	OVRES	MODF	TDRE	RDRF

0 = No effect.

1 = Enables the corresponding interrupt.

- **RDRF: Receive Data Register Full Interrupt Enable**
- **TDRE: SPI Transmit Data Register Empty Interrupt Enable**
- **MODF: Mode Fault Error Interrupt Enable**
- **OVRES: Overrun Error Interrupt Enable**
- **ENDRX: End of Receive Buffer Interrupt Enable**
- **ENDTX: End of Transmit Buffer Interrupt Enable**
- **RXBUFF: Receive Buffer Full Interrupt Enable**
- **TXBUFE: Transmit Buffer Empty Interrupt Enable**
- **NSSR: NSS Rising Interrupt Enable**
- **TXEMPTY: Transmission Registers Empty Enable**
- **UNDES: Underrun Error Interrupt Enable**

31.8.7 SPI Interrupt Disable Register

Name: SPI_IDR
Address: 0x40008018
Access: Write-only

31	30	29	28	27	26	25	24
–	–	–	–	–	–	–	–
23	22	21	20	19	18	17	16
–	–	–	–	–	–	–	–
15	14	13	12	11	10	9	8
–	–	–	–	–	UNDES	TXEMPTY	NSSR
7	6	5	4	3	2	1	0
TXBUFE	RXBUFF	ENDTX	ENDRX	OVRES	MODF	TDRE	RDRF

0 = No effect.

1 = Disables the corresponding interrupt.

- **RDRF: Receive Data Register Full Interrupt Disable**
- **TDRE: SPI Transmit Data Register Empty Interrupt Disable**
- **MODF: Mode Fault Error Interrupt Disable**
- **OVRES: Overrun Error Interrupt Disable**
- **ENDRX: End of Receive Buffer Interrupt Disable**
- **ENDTX: End of Transmit Buffer Interrupt Disable**
- **RXBUFF: Receive Buffer Full Interrupt Disable**
- **TXBUFE: Transmit Buffer Empty Interrupt Disable**
- **NSSR: NSS Rising Interrupt Disable**
- **TXEMPTY: Transmission Registers Empty Disable**
- **UNDES: Underrun Error Interrupt Disable**

31.8.8 SPI Interrupt Mask Register

Name: SPI_IMR
Address: 0x4000801C
Access: Read-only

31	30	29	28	27	26	25	24
–	–	–	–	–	–	–	–
23	22	21	20	19	18	17	16
–	–	–	–	–	–	–	–
15	14	13	12	11	10	9	8
–	–	–	–	–	UNDES	TXEMPTY	NSSR
7	6	5	4	3	2	1	0
TXBUFE	RXBUFF	ENDTX	ENDRX	OVRES	MODF	TDRE	RDRF

0 = The corresponding interrupt is not enabled.

1 = The corresponding interrupt is enabled.

- **RDRF: Receive Data Register Full Interrupt Mask**
- **TDRE: SPI Transmit Data Register Empty Interrupt Mask**
- **MODF: Mode Fault Error Interrupt Mask**
- **OVRES: Overrun Error Interrupt Mask**
- **ENDRX: End of Receive Buffer Interrupt Mask**
- **ENDTX: End of Transmit Buffer Interrupt Mask**
- **RXBUFF: Receive Buffer Full Interrupt Mask**
- **TXBUFE: Transmit Buffer Empty Interrupt Mask**
- **NSSR: NSS Rising Interrupt Mask**
- **TXEMPTY: Transmission Registers Empty Mask**
- **UNDES: Underrun Error Interrupt Mask**

31.8.9 SPI Chip Select Register

Name: SPI_CSRx[x=0..3]

Address: 0x40008030

Access: Read/Write

31	30	29	28	27	26	25	24
DLYBCT							
23	22	21	20	19	18	17	16
DLYBS							
15	14	13	12	11	10	9	8
SCBR							
7	6	5	4	3	2	1	0
BITS				CSAAT	CSNAAT	NCPHA	CPOL

This register can only be written if the WPEN bit is cleared in "SPI Write Protection Mode Register".

Note: SPI_CSRx registers must be written even if the user wants to use the defaults. The BITS field will not be updated with the translated value unless the register is written.

- **CPOL: Clock Polarity**

0 = The inactive state value of SPCK is logic level zero.

1 = The inactive state value of SPCK is logic level one.

CPOL is used to determine the inactive state value of the serial clock (SPCK). It is used with NCPHA to produce the required clock/data relationship between master and slave devices.

- **NCPHA: Clock Phase**

0 = Data is changed on the leading edge of SPCK and captured on the following edge of SPCK.

1 = Data is captured on the leading edge of SPCK and changed on the following edge of SPCK.

NCPHA determines which edge of SPCK causes data to change and which edge causes data to be captured. NCPHA is used with CPOL to produce the required clock/data relationship between master and slave devices.

- **CSNAAT: Chip Select Not Active After Transfer (Ignored if CSAAT = 1)**

0 = The Peripheral Chip Select does not rise between two transfers if the SPI_TDR is reloaded before the end of the first transfer and if the two transfers occur on the same Chip Select.

1 = The Peripheral Chip Select rises systematically after each transfer performed on the same slave. It remains active after the end of transfer for a minimal duration of:

- $\frac{DLYBCT}{MCK}$ (if DLYBCT field is different from 0)

- $\frac{DLYBCT + 1}{MCK}$ (if DLYBCT field equals 0)

- **CSAAT: Chip Select Active After Transfer**

0 = The Peripheral Chip Select Line rises as soon as the last transfer is achieved.

1 = The Peripheral Chip Select does not rise after the last transfer is achieved. It remains active until a new transfer is requested on a different chip select.

- **BITS: Bits Per Transfer**

(See the ^(Note:) below the register table; [Section 31.8.9 “SPI Chip Select Register”](#) on page 662.)

The BITS field determines the number of data bits transferred. Reserved values should not be used.

Value	Name	Description
0	8_BIT	8 bits for transfer
1	9_BIT	9 bits for transfer
2	10_BIT	10 bits for transfer
3	11_BIT	11 bits for transfer
4	12_BIT	12 bits for transfer
5	13_BIT	13 bits for transfer
6	14_BIT	14 bits for transfer
7	15_BIT	15 bits for transfer
8	16_BIT	16 bits for transfer
9	–	Reserved
10	–	Reserved
11	–	Reserved
12	–	Reserved
13	–	Reserved
14	–	Reserved
15	–	Reserved

- **SCBR: Serial Clock Baud Rate**

In Master Mode, the SPI Interface uses a modulus counter to derive the SPCK baud rate from the Master Clock MCK. The Baud rate is selected by writing a value from 1 to 255 in the SCBR field. The following equations determine the SPCK baud rate:

$$\text{SPCK Baudrate} = \frac{MCK}{SCBR}$$

Programming the SCBR field at 0 is forbidden. Triggering a transfer while SCBR is at 0 can lead to unpredictable results.

At reset, SCBR is 0 and the user has to program it at a valid value before performing the first transfer.

Note: If one of the SCBR fields in SPI_CSRx is set to 1, the other SCBR fields in SPI_CSRx must be set to 1 as well, if they are required to process transfers. If they are not used to transfer data, they can be set at any value.

- **DLYBS: Delay Before SPCK**

This field defines the delay from NPCS valid to the first valid SPCK transition.

When DLYBS equals zero, the NPCS valid to SPCK transition is 1/2 the SPCK clock period.

Otherwise, the following equations determine the delay:

$$\text{Delay Before SPCK} = \frac{DLYBS}{MCK}$$

- **DLYBCT: Delay Between Consecutive Transfers**

This field defines the delay between two consecutive transfers with the same peripheral without removing the chip select. The delay is always inserted after each transfer and before removing the chip select if needed.

When DLYBCT equals zero, no delay between consecutive transfers is inserted and the clock keeps its duty cycle over the character transfers.

Otherwise, the following equation determines the delay:

$$\text{Delay Between Consecutive Transfers} = \frac{32 \times DLYBCT}{MCK}$$

31.8.10 SPI Write Protection Mode Register

Name: SPI_WPMR
Address: 0x400080E4
Access: Read-write

31	30	29	28	27	26	25	24
WPKEY							
23	22	21	20	19	18	17	16
WPKEY							
15	14	13	12	11	10	9	8
WPKEY							
7	6	5	4	3	2	1	0
-	-	-	-	-	-	-	WPEN

- WPEN: Write Protection Enable**

0: The Write Protection is Disabled

1: The Write Protection is Enabled

- WPKEY: Write Protection Key Password**

If a value is written in WPEN, the value is taken into account only if WPKEY is written with "SPI" (SPI written in ASCII Code, ie 0x535049 in hexadecimal).

List of the write-protected registers:

[Section 31.8.2 "SPI Mode Register"](#)

[Section 31.8.9 "SPI Chip Select Register"](#)

31.8.11 SPI Write Protection Status Register

Name: SPI_WPSR
Address: 0x400080E8
Access: Read-only

31	30	29	28	27	26	25	24
–	–	–	–	–	–	–	–
23	22	21	20	19	18	17	16
–	–	–	–	–	–	–	–
15	14	13	12	11	10	9	8
WPVSR							
7	6	5	4	3	2	1	0
–	–	–	–	–	–	–	WPVS

- **WPVS: Write Protection Violation Status**

0 = No Write Protect Violation has occurred since the last read of the SPI_WPSR register.

1 = A Write Protect Violation has occurred since the last read of the SPI_WPSR register. If this violation is an unauthorized attempt to write a protected register, the associated violation is reported into field WPVSR.

- **WPVSR: Write Protection Violation Source**

This Field indicates the APB Offset of the register concerned by the violation (SPI_MR or SPI_CSRx)

32. Two-wire Interface (TWI)

32.1 Description

The Atmel Two-wire Interface (TWI) interconnects components on a unique two-wire bus, made up of one clock line and one data line with speeds of up to 400 Kbits per second, based on a byte-oriented transfer format. It can be used with any Atmel Two-wire Interface bus Serial EEPROM and I²C compatible device such as Real Time Clock (RTC), Dot Matrix/Graphic LCD Controllers and Temperature Sensor, to name but a few. The TWI is programmable as a master or a slave with sequential or single-byte access. Multiple master capability is supported. 20

Arbitration of the bus is performed internally and puts the TWI in slave mode automatically if the bus arbitration is lost.

A configurable baud rate generator permits the output data rate to be adapted to a wide range of core clock frequencies.

Below, [Table 32-1](#) lists the compatibility level of the Atmel Two-wire Interface in Master Mode and a full I2C compatible device.

Table 32-1. Atmel TWI compatibility with i2C Standard

I2C Standard	Atmel TWI
Standard Mode Speed (100 KHz)	Supported
Fast Mode Speed (400 KHz)	Supported
7 or 10 bits Slave Addressing	Supported
START BYTE ⁽¹⁾	Not Supported
Repeated Start (Sr) Condition	Supported
ACK and NACK Management	Supported
Slope control and input filtering (Fast mode)	Not Supported
Clock stretching	Supported
Multi Master Capability	Supported

Note: 1. START + b000000001 + Ack + Sr

32.2 Embedded Characteristics

- Master, Multi-Master and Slave Mode Operation
- Compatibility with Atmel two-wire interface, serial memory and I²C compatible devices
- One, two or three bytes for slave address
- Sequential read/write operations
- Bit Rate: Up to 400 kbit/s
- General Call Supported in Slave Mode
- Connection to PDC channel capabilities optimizes data transfers in Master Mode only
 - One channel for the receiver, one channel for the transmitter
 - Next buffer support

32.3 List of Abbreviations

Table 32-2. Abbreviations

Abbreviation	Description
TWI	Two-wire Interface
A	Acknowledge
NA	Non Acknowledge
P	Stop
S	Start
Sr	Repeated Start
SADR	Slave Address
ADR	Any address except SADR
R	Read
W	Write

32.4 Block Diagram

Figure 32-1. Block Diagram

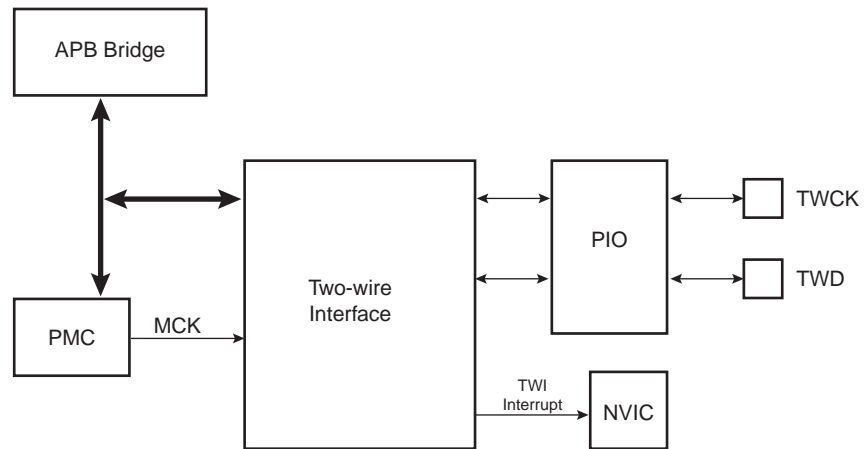

32.5 Application Block Diagram

Figure 32-2. Application Block Diagram

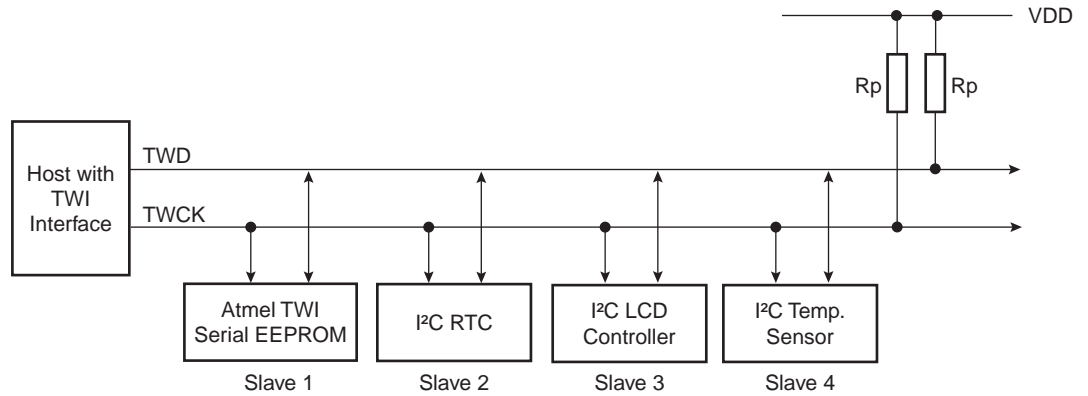

Rp: Pull up value as given by the I²C Standard

32.5.1 I/O Lines Description

Table 32-3. I/O Lines Description

Pin Name	Pin Description	Type
TWD	Two-wire Serial Data	Input/Output
TWCK	Two-wire Serial Clock	Input/Output

32.6 Product Dependencies

32.6.1 I/O Lines

Both TWD and TWCK are bidirectional lines, connected to a positive supply voltage via a current source or pull-up resistor (see [Figure 32-2 on page 669](#)). When the bus is free, both lines are high. The output stages of devices connected to the bus must have an open-drain or open-collector to perform the wired-AND function.

TWD and TWCK pins may be multiplexed with PIO lines. To enable the TWI, the programmer must perform the following step:

- Program the PIO controller to dedicate TWD and TWCK as peripheral lines.

The user must not program TWD and TWCK as open-drain. It is already done by the hardware.

Table 32-4. I/O Lines

Instance	Signal	I/O Line	Peripheral
TWI0	TWCK0	PA4	A
TWI0	TWD0	PA3	A
TWI1	TWCK1	PB5	A
TWI1	TWD1	PB4	A

32.6.2 Power Management

- Enable the peripheral clock.

The TWI interface may be clocked through the Power Management Controller (PMC), thus the programmer must first configure the PMC to enable the TWI clock.

32.6.3 Interrupt

The TWI interface has an interrupt line connected to the Nested Vector Interrupt Controller (NVIC). In order to handle interrupts, the NVIC must be programmed before configuring the TWI.

Table 32-5. Peripheral IDs

Instance	ID
TWI0	19
TWI1	20

32.7 Functional Description

32.7.1 Transfer Format

The data put on the TWD line must be 8 bits long. Data is transferred MSB first; each byte must be followed by an acknowledgement. The number of bytes per transfer is unlimited (see [Figure 32-4](#)).

Each transfer begins with a START condition and terminates with a STOP condition (see [Figure 32-3](#)).

- A high-to-low transition on the TWD line while TWCK is high defines the START condition.
- A low-to-high transition on the TWD line while TWCK is high defines a STOP condition.

Figure 32-3. START and STOP Conditions

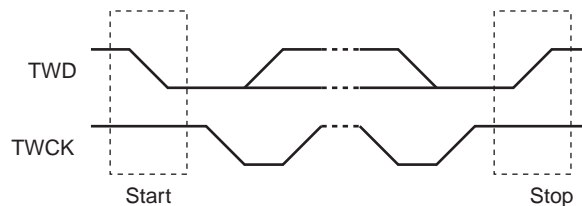
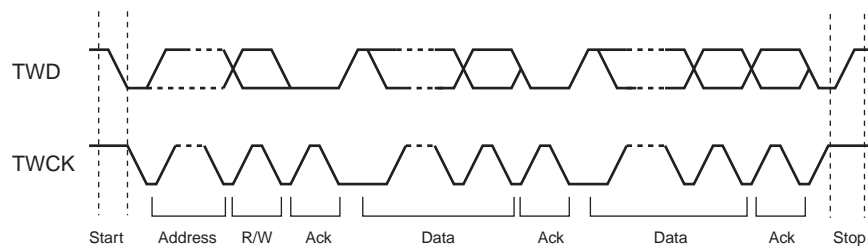

Figure 32-4. Transfer Format



32.7.2 Modes of Operation

The TWI has six modes of operations:

- Master transmitter mode
- Master receiver mode
- Multi-master transmitter mode
- Multi-master receiver mode
- Slave transmitter mode
- Slave receiver mode

These modes are described in the following chapters.

32.8 Master Mode

32.8.1 Definition

The Master is the device that starts a transfer, generates a clock and stops it.

32.8.2 Application Block Diagram

Figure 32-5. Master Mode Typical Application Block Diagram

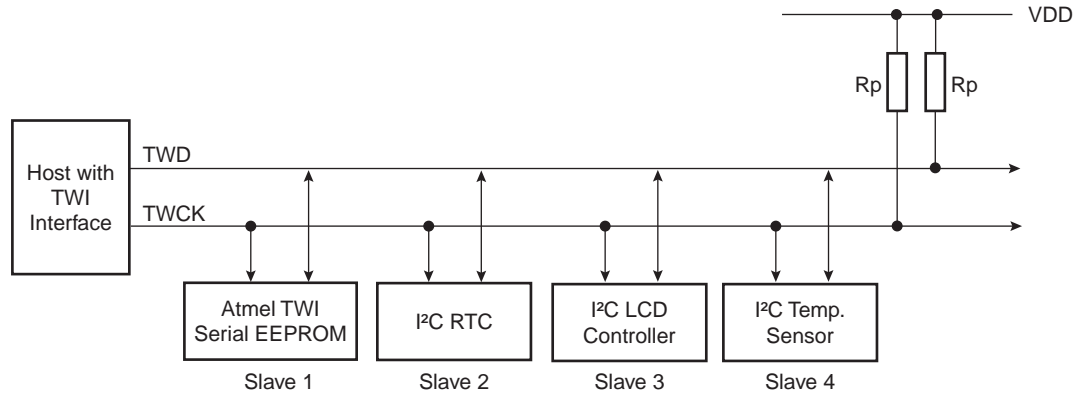

Rp: Pull up value as given by the I²C Standard

32.8.3 Programming Master Mode

The following registers have to be programmed before entering Master mode:

1. DADR (+ IADRSZ + IADR if a 10 bit device is addressed): The device address is used to access slave devices in read or write mode.
2. CKDIV + CHDIV + CLDIV: Clock Waveform.
3. SVDIS: Disable the slave mode.
4. MSEN: Enable the master mode.

32.8.4 Master Transmitter Mode

After the master initiates a Start condition when writing into the Transmit Holding Register, TWI_THR, it sends a 7-bit slave address, configured in the Master Mode register (DADR in TWI_MMR), to notify the slave device. The bit following the slave address indicates the transfer direction, 0 in this case (MREAD = 0 in TWI_MMR).

The TWI transfers require the slave to acknowledge each received byte. During the acknowledge clock pulse (9th pulse), the master releases the data line (HIGH), enabling the slave to pull it down in order to generate the acknowledge. The master polls the data line during this clock pulse and sets the Not Acknowledge bit (**NACK**) in the status register if the slave does not acknowledge the byte. As with the other status bits, an interrupt can be generated if enabled in the interrupt enable register (TWI_IER). If the slave acknowledges the byte, the data written in the TWI_THR, is then shifted in the internal shifter and transferred. When an acknowledge is detected, the TXRDY bit is set until a new write in the TWI_THR.

TXRDY is used as Transmit Ready for the PDC transmit channel.

While no new data is written in the TWI_THR, the Serial Clock Line is tied low. When new data is written in the TWI_THR, the SCL is released and the data is sent. To generate a STOP event, the STOP command must be performed by writing in the STOP field of TWI_CR.

After a Master Write transfer, the Serial Clock line is stretched (tied low) while no new data is written in the TWI_THR or until a STOP command is performed.

See [Figure 32-6](#), [Figure 32-7](#), and [Figure 32-8](#).

Figure 32-6. Master Write with One Data Byte

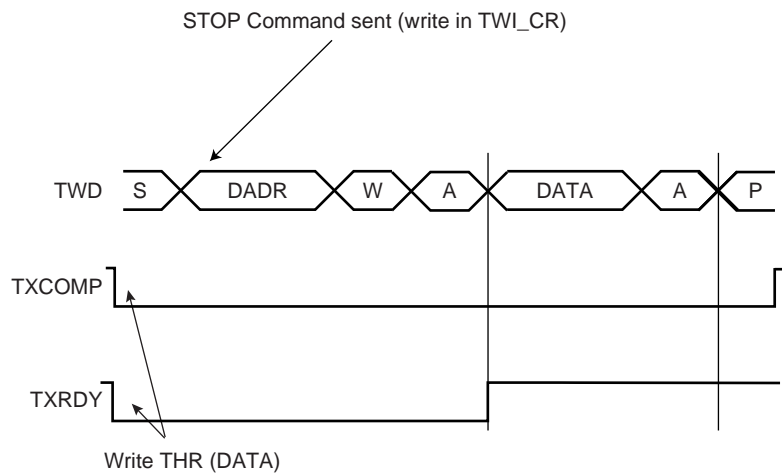

Figure 32-7. Master Write with Multiple Data Bytes

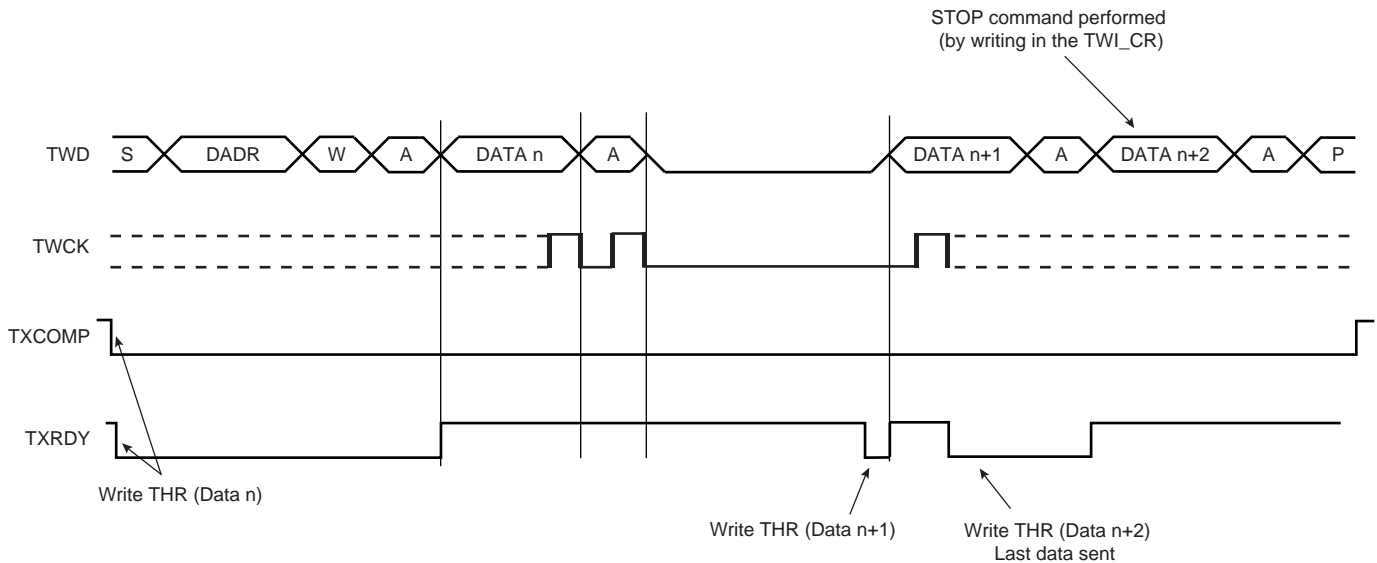
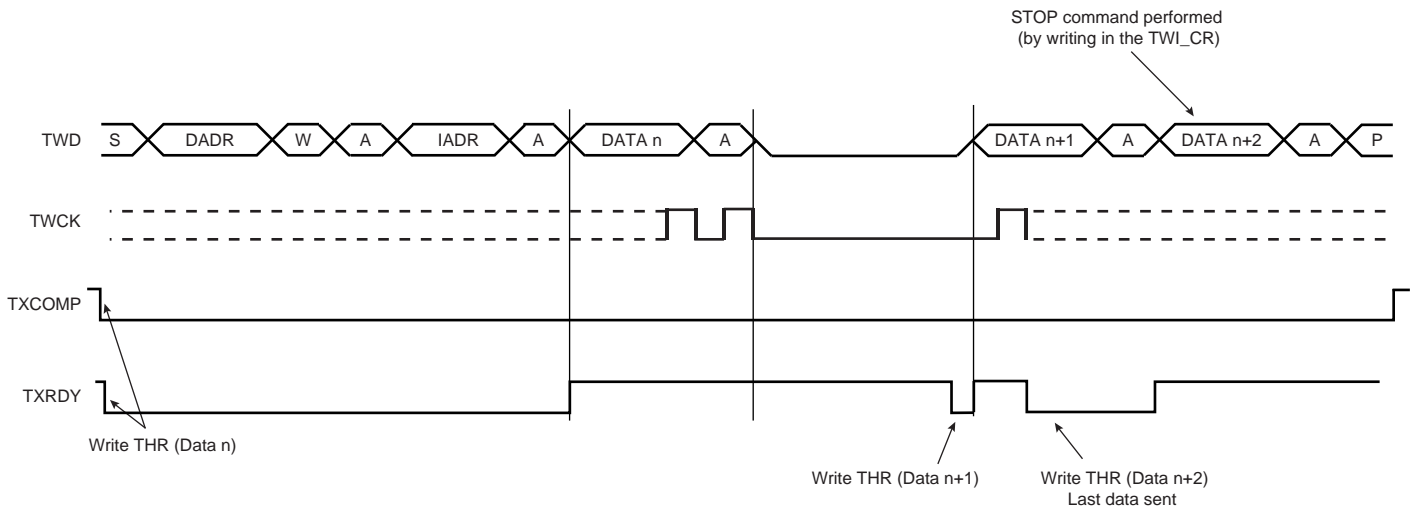

Figure 32-8. Master Write with One Byte Internal Address and Multiple Data Bytes



32.8.5 Master Receiver Mode

The read sequence begins by setting the START bit. After the start condition has been sent, the master sends a 7-bit slave address to notify the slave device. The bit following the slave address indicates the transfer direction, 1 in this case (MREAD = 1 in TWI_MMR). During the acknowledge clock pulse (9th pulse), the master releases the data line (HIGH), enabling the slave to pull it down in order to generate the acknowledge. The master polls the data line during this clock pulse and sets the **NACK** bit in the status register if the slave does not acknowledge the byte.

If an acknowledge is received, the master is then ready to receive data from the slave. After data has been received, the master sends an acknowledge condition to notify the slave that the data has been received except for the last data, after the stop condition. See [Figure 32-9](#). When the RXRDY bit is set in the status register, a character has been received in the receive-holding register (TWI_RHR). The RXRDY bit is reset when reading the TWI_RHR.

When a single data byte read is performed, with or without internal address (**IADR**), the START and STOP bits must be set at the same time. See [Figure 32-9](#). When a multiple data byte read is performed, with or without internal address (**IADR**), the STOP bit must be set after the next-to-last data received. See [Figure 32-10](#). For Internal Address usage see [Section 32.8.6](#).

Figure 32-9. Master Read with One Data Byte

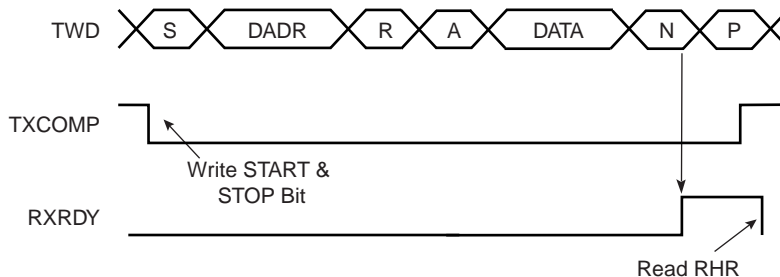
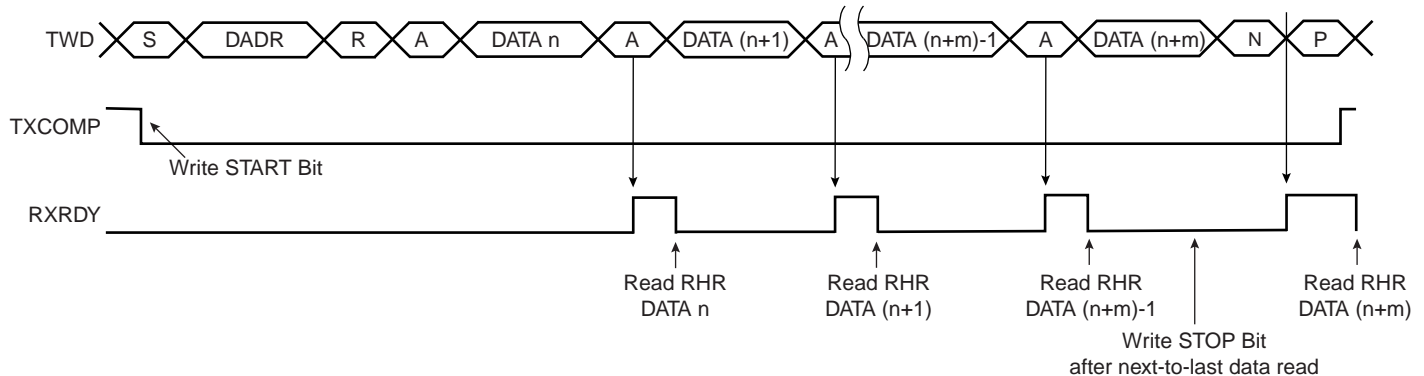

Figure 32-10. Master Read with Multiple Data Bytes



RXRDY is used as Receive Ready for the PDC receive channel.

32.8.6 Internal Address

The TWI interface can perform various transfer formats: Transfers with 7-bit slave address devices and 10-bit slave address devices.

32.8.6.1 7-bit Slave Addressing

When Addressing 7-bit slave devices, the internal address bytes are used to perform random address (read or write) accesses to reach one or more data bytes, within a memory page location in a serial memory, for example. When performing read operations with an internal address, the TWI performs a write operation to set the internal address into the slave device, and then switch to Master Receiver mode. Note that the second start condition (after sending the IADR) is sometimes called “repeated start” (Sr) in I2C fully-compatible devices. See [Figure 32-12](#). See [Figure 32-11](#) and [Figure 32-13](#) for Master Write operation with internal address.

The three internal address bytes are configurable through the Master Mode register (TWI_MMR).

If the slave device supports only a 7-bit address, i.e. no internal address, **IADRSZ** must be set to 0.

In the figures below the following abbreviations are used:

- S Start
- Sr Repeated Start
- P Stop
- W Write
- R Read
- A Acknowledge
- N Not Acknowledge
- DADR Device Address
- IADR Internal Address

Figure 32-11. Master Write with One, Two or Three Bytes Internal Address and One Data Byte

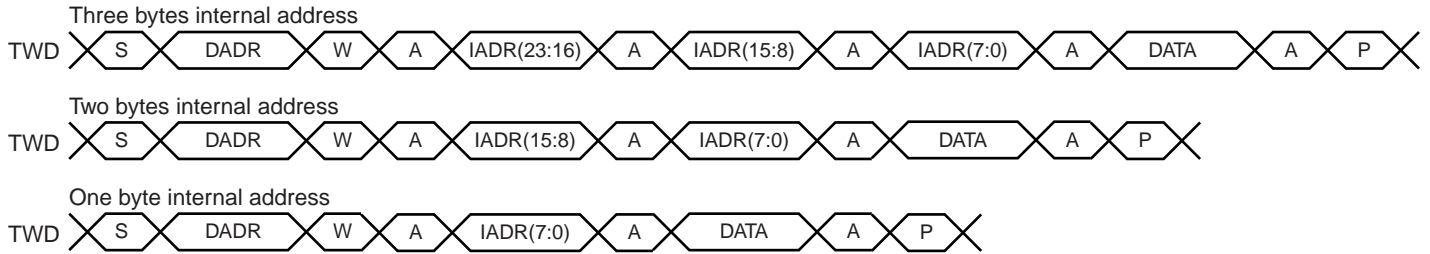
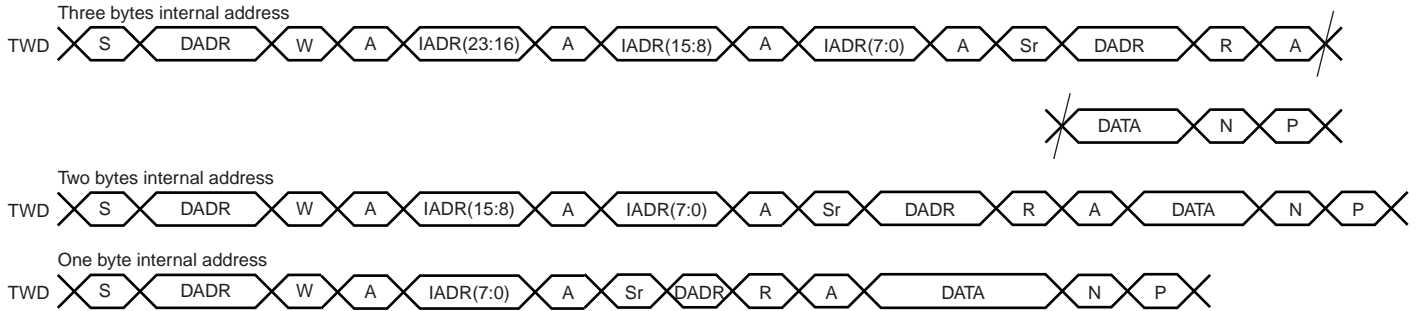

Figure 32-12. Master Read with One, Two or Three Bytes Internal Address and One Data Byte



32.8.6.2 10-bit Slave Addressing

For a slave address higher than 7 bits, the user must configure the address size (**IADRSZ**) and set the other slave address bits in the internal address register (TWI_IADR). The two remaining Internal address bytes, IADR[15:8] and IADR[23:16] can be used the same as in 7-bit Slave Addressing.

Example: Address a 10-bit device (10-bit device address is b1 b2 b3 b4 b5 b6 b7 b8 b9 b10)

1. Program IADRSZ = 1,
2. Program DADR with 1 1 1 1 0 b1 b2 (b1 is the MSB of the 10-bit address, b2, etc.)
3. Program TWI_IADR with b3 b4 b5 b6 b7 b8 b9 b10 (b10 is the LSB of the 10-bit address)

Figure 32-13 below shows a byte write to an Atmel AT24LC512 EEPROM. This demonstrates the use of internal addresses to access the device.

Figure 32-13. Internal Address Usage

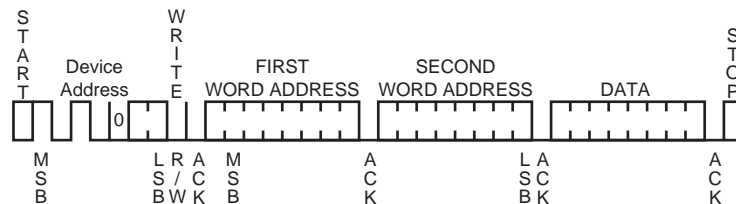

32.8.7 Using the Peripheral DMA Controller (PDC)

The use of the PDC significantly reduces the CPU load.

To assure correct implementation, respect the following programming sequences:

32.8.7.1 Data Transmit with the PDC

1. Initialize the transmit PDC (memory pointers, size, etc.).
2. Configure the master mode (DADR, CKDIV, etc.).
3. Start the transfer by setting the PDC TXTEN bit.
4. Wait for the PDC end TX flag.
5. Disable the PDC by setting the PDC TXDIS bit.

32.8.7.2 Data Receive with the PDC

1. Initialize the receive PDC (memory pointers, size - 1, etc.).
2. Configure the master mode (DADR, CKDIV, etc.).
3. Start the transfer by setting the PDC RXTEN bit.
4. Wait for the PDC end RX flag.
5. Disable the PDC by setting the PDC RXDIS bit.

32.8.8 SMBUS Quick Command (Master Mode Only)

The TWI interface can perform a Quick Command:

1. Configure the master mode (DADR, CKDIV, etc.).
2. Write the MREAD bit in the TWI_MMR register at the value of the one-bit command to be sent.
3. Start the transfer by setting the QUICK bit in the TWI_CR.

Figure 32-14. SMBUS Quick Command

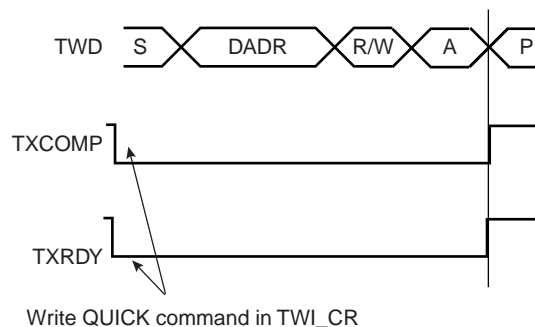

32.8.9 Read-write Flowcharts

The following flowcharts shown in [Figure 32-16 on page 679](#), [Figure 32-17 on page 680](#), [Figure 32-18 on page 681](#), [Figure 32-19 on page 682](#) and [Figure 32-20 on page 683](#) give examples for read and write operations. A polling or interrupt method can be used to check the status bits. The interrupt method requires that the interrupt enable register (TWI_IER) be configured first.

Figure 32-15. TWI Write Operation with Single Data Byte without Internal Address

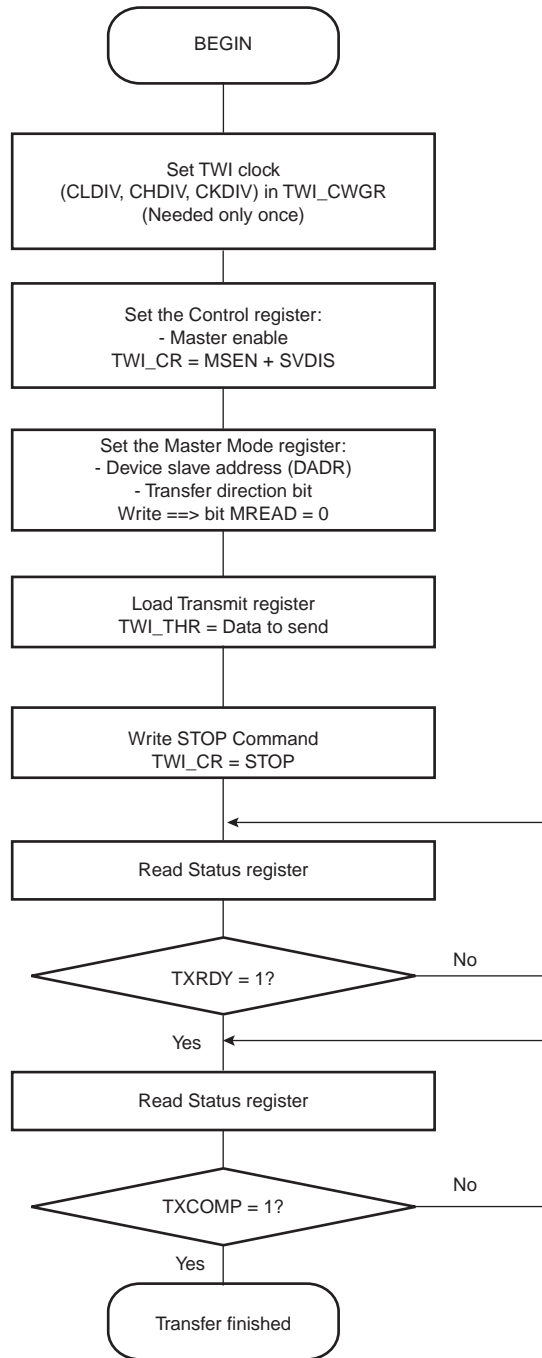

Figure 32-16. TWI Write Operation with Single Data Byte and Internal Address

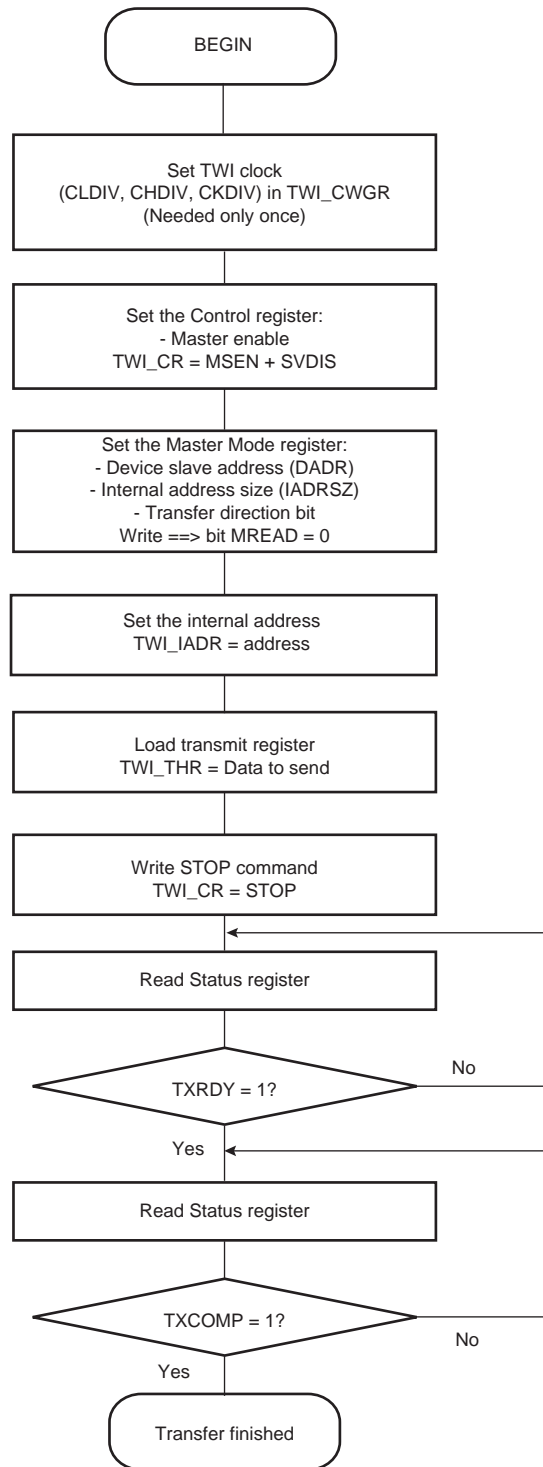

Figure 32-17. TWI Write Operation with Multiple Data Bytes with or without Internal Address

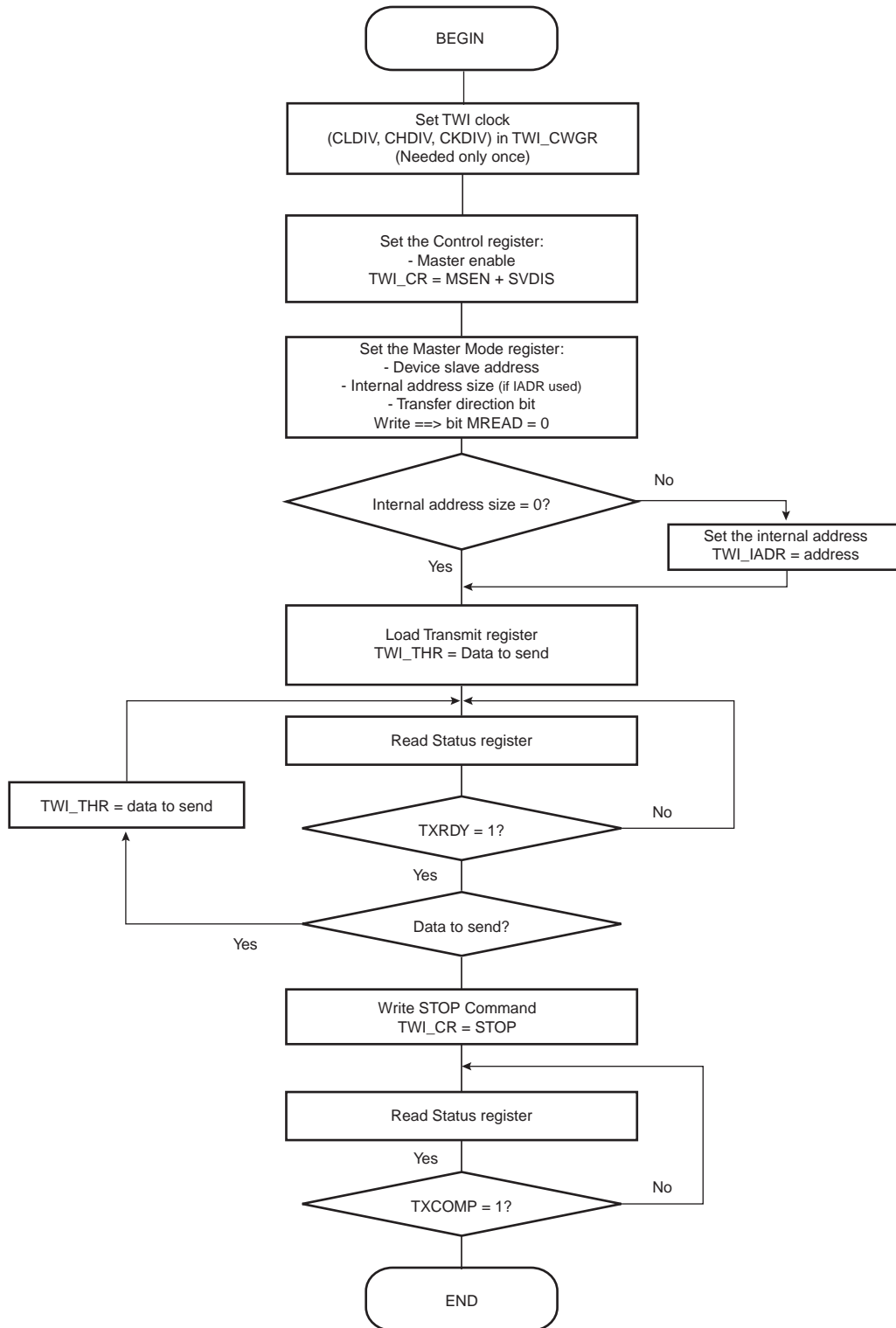

Figure 32-18. TWI Read Operation with Single Data Byte without Internal Address

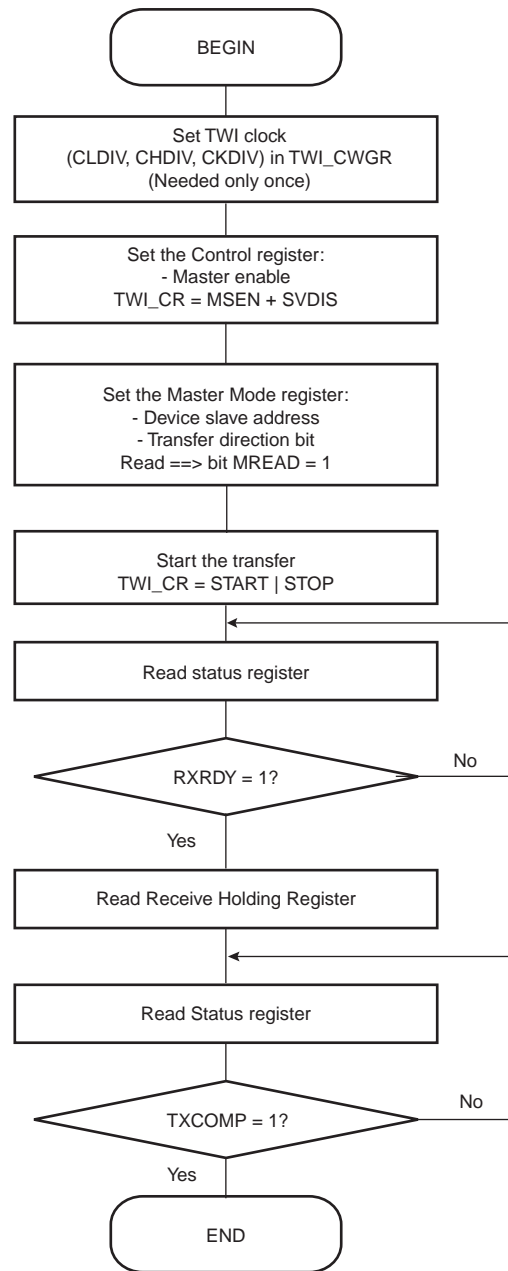

Figure 32-19. TWI Read Operation with Single Data Byte and Internal Address

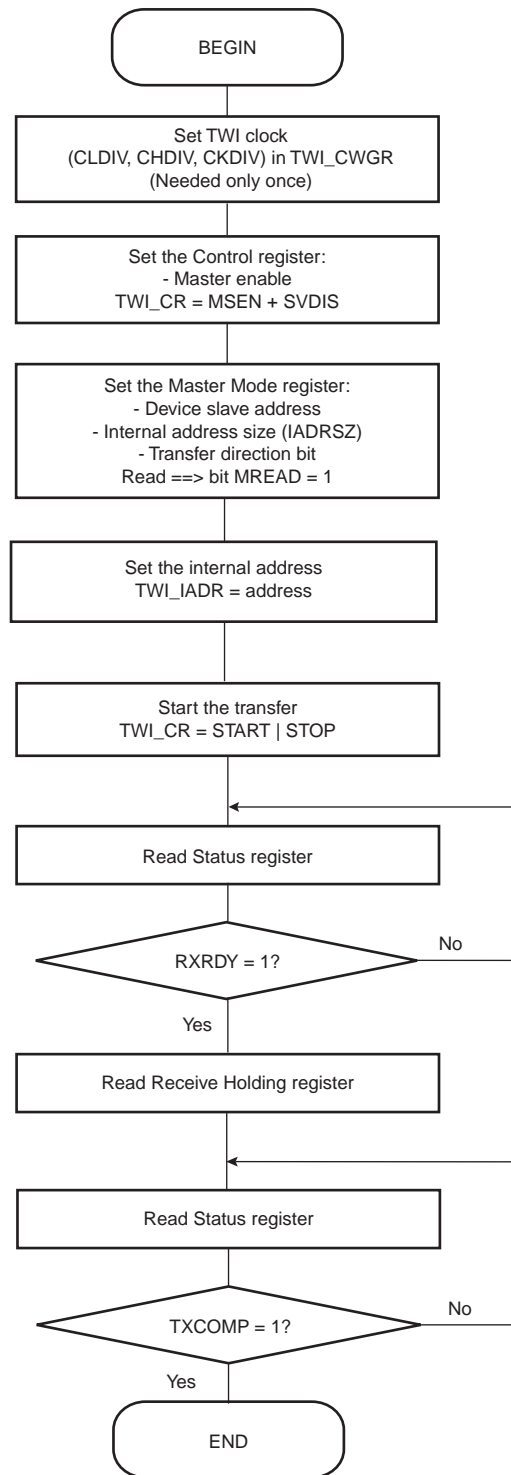
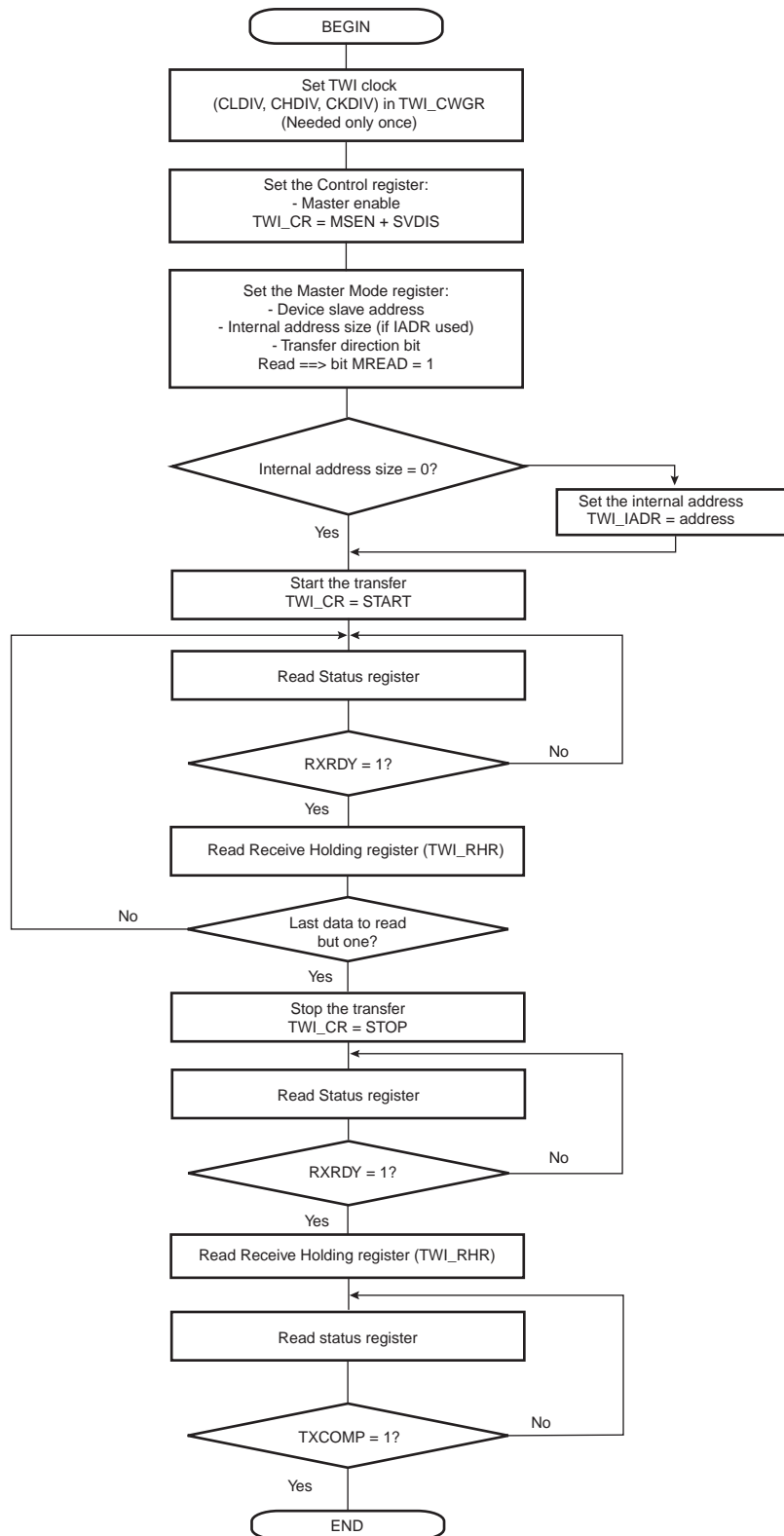

Figure 32-20. TWI Read Operation with Multiple Data Bytes with or without Internal Address



32.9 Multi-master Mode

32.9.1 Definition

More than one master may handle the bus at the same time without data corruption by using arbitration.

Arbitration starts as soon as two or more masters place information on the bus at the same time, and stops (arbitration is lost) for the master that intends to send a logical one while the other master sends a logical zero.

As soon as arbitration is lost by a master, it stops sending data and listens to the bus in order to detect a stop. When the stop is detected, the master who has lost arbitration may put its data on the bus by respecting arbitration.

Arbitration is illustrated in [Figure 32-22 on page 685](#).

32.9.2 Different Multi-master Modes

Two multi-master modes may be distinguished:

1. TWI is considered as a Master only and will never be addressed.
2. TWI may be either a Master or a Slave and may be addressed.

Note: In both Multi-master modes arbitration is supported.

32.9.2.1 *TWI as Master Only*

In this mode, TWI is considered as a Master only (MSEN is always at one) and must be driven like a Master with the ARBLST (ARBitration Lost) flag in addition.

If arbitration is lost (ARBLST = 1), the programmer must reinitiate the data transfer.

If the user starts a transfer (ex.: DADR + START + W + Write in THR) and if the bus is busy, the TWI automatically waits for a STOP condition on the bus to initiate the transfer (see [Figure 32-21 on page 685](#)).

Note: The state of the bus (busy or free) is not indicated in the user interface.

32.9.2.2 *TWI as Master or Slave*

The automatic reversal from Master to Slave is not supported in case of a lost arbitration.

Then, in the case where TWI may be either a Master or a Slave, the programmer must manage the pseudo Multi-master mode described in the steps below.

1. Program TWI in Slave mode (SADR + MSDIS + SVEN) and perform Slave Access (if TWI is addressed).
2. If TWI has to be set in Master mode, wait until TXCOMP flag is at 1.
3. Program Master mode (DADR + SVDIS + MSEN) and start the transfer (ex: START + Write in THR).
4. As soon as the Master mode is enabled, TWI scans the bus in order to detect if it is busy or free. When the bus is considered as free, TWI initiates the transfer.
5. As soon as the transfer is initiated and until a STOP condition is sent, the arbitration becomes relevant and the user must monitor the ARBLST flag.
6. If the arbitration is lost (ARBLST is set to 1), the user must program the TWI in Slave mode in the case where the Master that won the arbitration wanted to access the TWI.
7. If TWI has to be set in Slave mode, wait until TXCOMP flag is at 1 and then program the Slave mode.

Note: In the case where the arbitration is lost and TWI is addressed, TWI will not acknowledge even if it is programmed in Slave mode as soon as ARBLST is set to 1. Then, the Master must repeat SADR.

Figure 32-21. Programmer Sends Data While the Bus is Busy

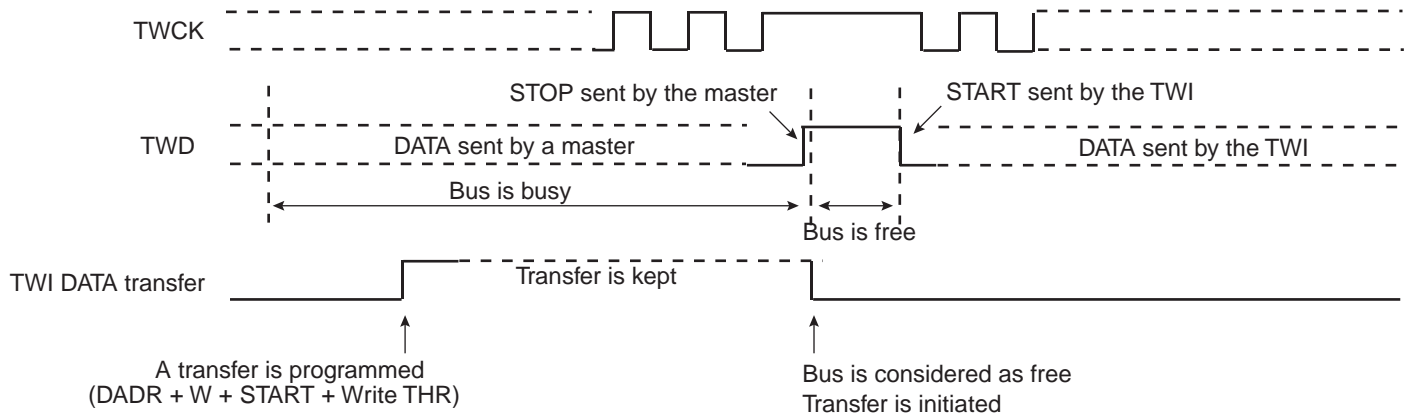
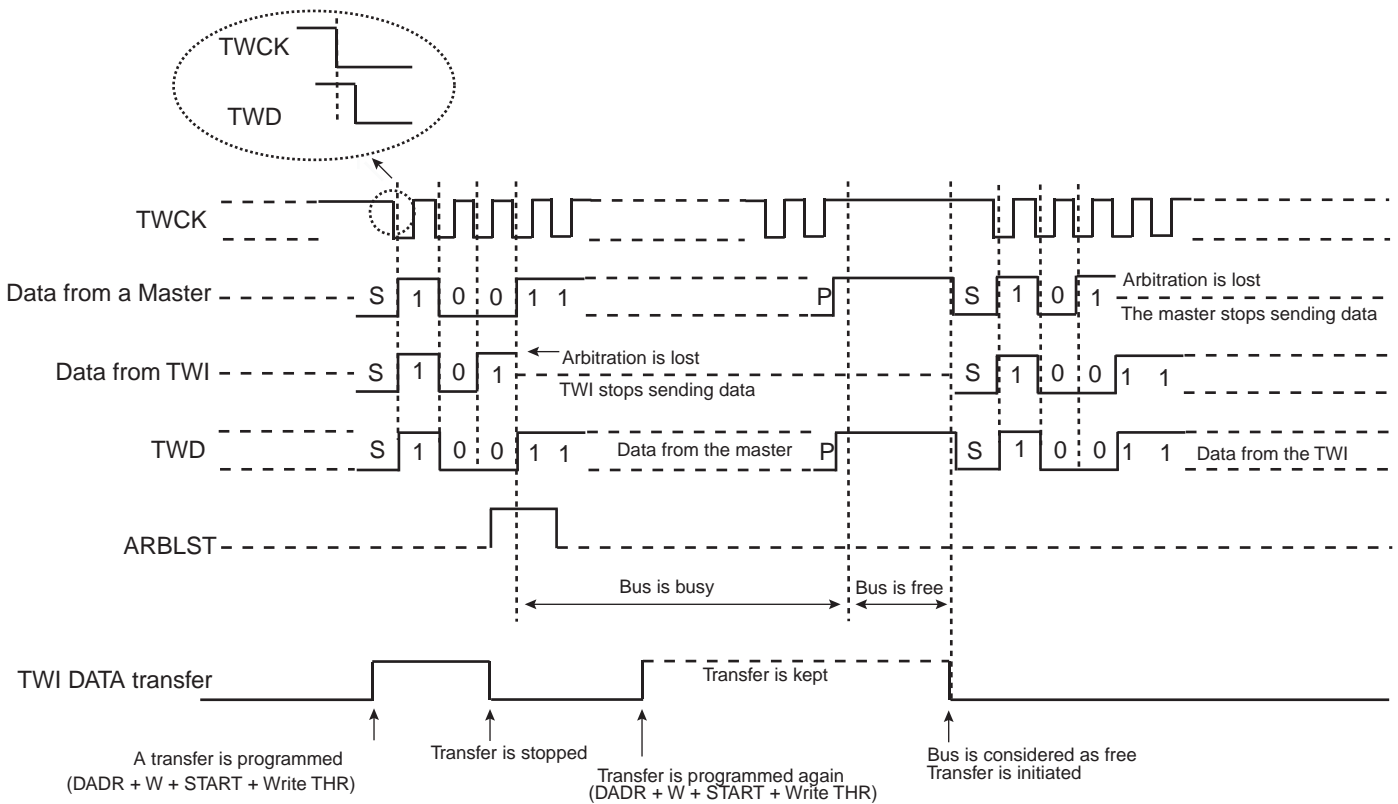
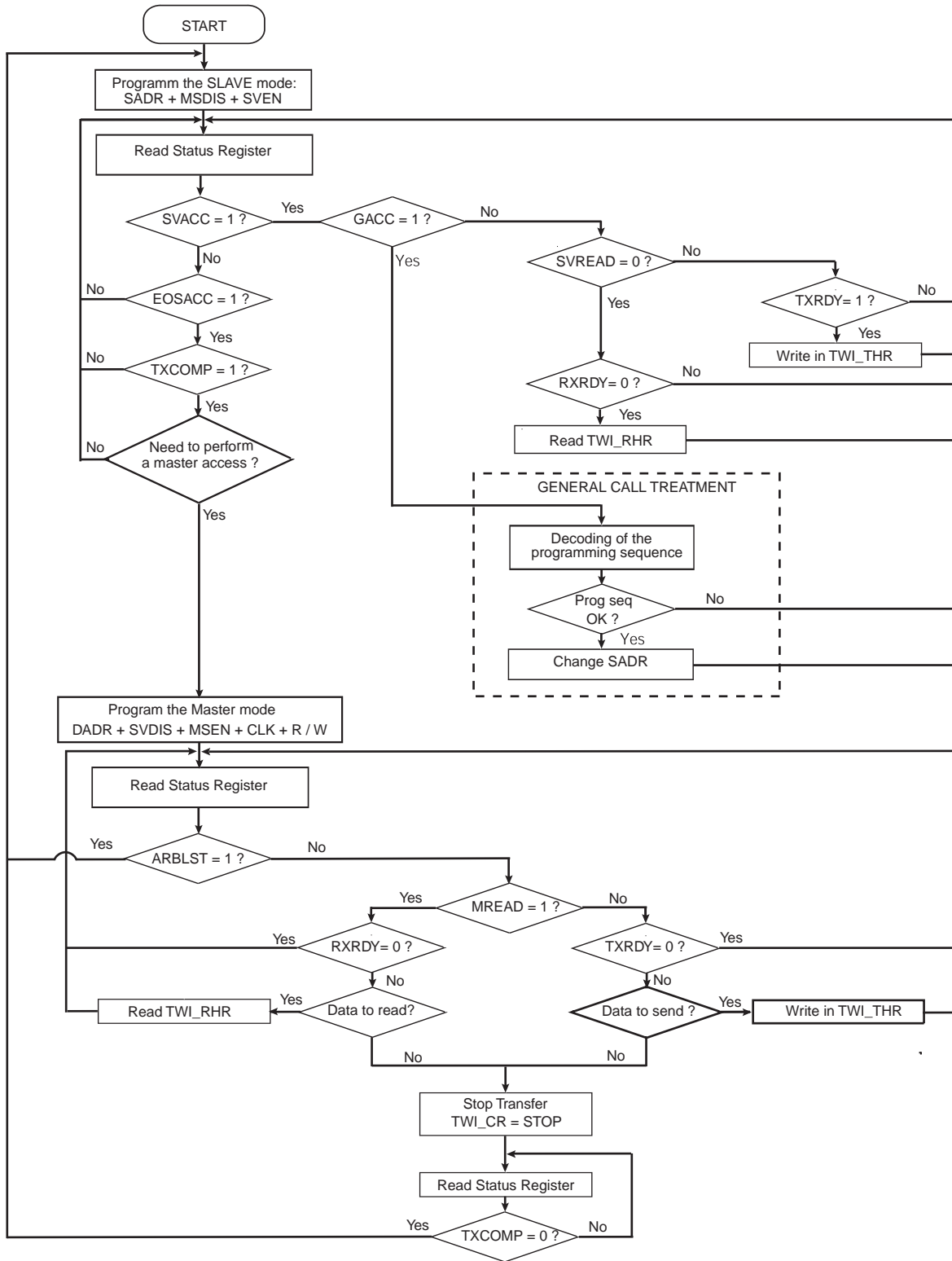

Figure 32-22. Arbitration Cases



The flowchart shown in [Figure 32-23 on page 686](#) gives an example of read and write operations in Multi-master mode.

Figure 32-23. Multi-master Flowchart



32.10 Slave Mode

32.10.1 Definition

The Slave Mode is defined as a mode where the device receives the clock and the address from another device called the master.

In this mode, the device never initiates and never completes the transmission (START, REPEATED_START and STOP conditions are always provided by the master).

32.10.2 Application Block Diagram

Figure 32-24. Slave Mode Typical Application Block Diagram

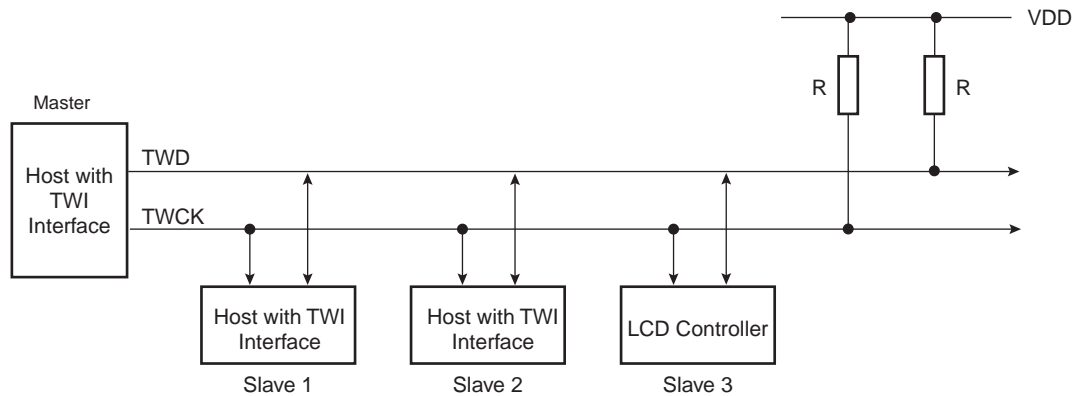

32.10.3 Programming Slave Mode

The following fields must be programmed before entering Slave mode:

1. SADR (TWI_SMR): The slave device address is used in order to be accessed by master devices in read or write mode.
2. MSDIS (TWI_CR): Disable the master mode.
3. SVEN (TWI_CR): Enable the slave mode.

As the device receives the clock, values written in TWI_CWGR are not taken into account.

32.10.4 Receiving Data

After a Start or Repeated Start condition is detected and if the address sent by the Master matches with the Slave address programmed in the SADR (Slave Address) field, SVACC (Slave Access) flag is set and SVREAD (Slave READ) indicates the direction of the transfer.

SVACC remains high until a STOP condition or a repeated START is detected. When such a condition is detected, EOSACC (End Of Slave Access) flag is set.

32.10.4.1 Read Sequence

In the case of a Read sequence (SVREAD is high), TWI transfers data written in the TWI_THR (TWI Transmit Holding Register) until a STOP condition or a REPEATED_START + an address different from SADR is detected. Note that at the end of the read sequence TXCOMP (Transmission Complete) flag is set and SVACC reset.

As soon as data is written in the TWI_THR, TXRDY (Transmit Holding Register Ready) flag is reset, and it is set when the shift register is empty and the sent data acknowledged or not. If the data is not acknowledged, the NACK flag is set.

Note that a STOP or a repeated START always follows a NACK.

See [Figure 32-25 on page 689](#).

32.10.4.2 Write Sequence

In the case of a Write sequence (SVREAD is low), the RXRDY (Receive Holding Register Ready) flag is set as soon as a character has been received in the TWI_RHR (TWI Receive Holding Register). RXRDY is reset when reading the TWI_RHR.

TWI continues receiving data until a STOP condition or a REPEATED_START + an address different from SADR is detected. Note that at the end of the write sequence TXCOMP flag is set and SVACC reset.

See [Figure 32-26 on page 689](#).

32.10.4.3 Clock Synchronization Sequence

In the case where TWI_THR or TWI_RHR is not written/read in time, TWI performs a clock synchronization.

Clock stretching information is given by the SCLWS (Clock Wait state) bit.

See [Figure 32-28 on page 691](#) and [Figure 32-29 on page 692](#).

32.10.4.4 General Call

In the case where a GENERAL CALL is performed, GACC (General Call ACCESS) flag is set.

After GACC is set, it is up to the programmer to interpret the meaning of the GENERAL CALL and to decode the new address programming sequence.

See [Figure 32-27 on page 690](#).

32.10.4.5 PDC

As it is impossible to know the exact number of data to receive/send, the use of PDC is NOT recommended in SLAVE mode.

32.10.5 Data Transfer

32.10.5.1 Read Operation

The read mode is defined as a data requirement from the master.

After a START or a REPEATED START condition is detected, the decoding of the address starts. If the slave address (SADR) is decoded, SVACC is set and SVREAD indicates the direction of the transfer.

Until a STOP or REPEATED START condition is detected, TWI continues sending data loaded in the TWI_THR register.

If a STOP condition or a REPEATED START + an address different from SADR is detected, SVACC is reset.

[Figure 32-25 on page 689](#) describes the write operation.

Figure 32-25. Read Access Ordered by a MASTER

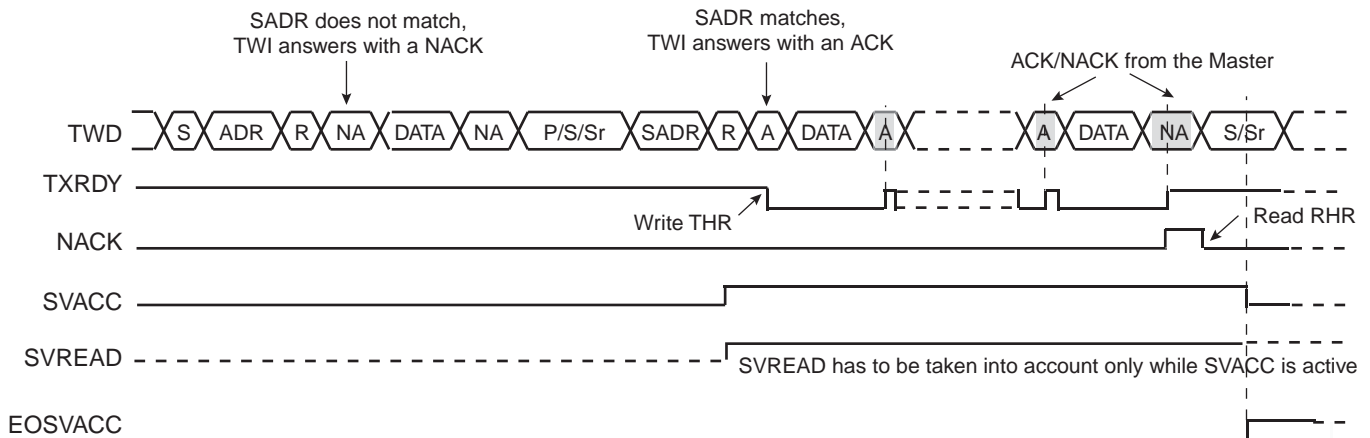

- Notes:
1. When SVACC is low, the state of SVREAD becomes irrelevant.
 2. TXRDY is reset when data has been transmitted from TWI_THR to the shift register and set when this data has been acknowledged or non acknowledged.

32.10.5.2 Write Operation

The write mode is defined as a data transmission from the master.

After a START or a REPEATED START, the decoding of the address starts. If the slave address is decoded, SVACC is set and SVREAD indicates the direction of the transfer (SVREAD is low in this case).

Until a STOP or REPEATED START condition is detected, TWI stores the received data in the TWI_RHR register.

If a STOP condition or a REPEATED START + an address different from SADR is detected, SVACC is reset.

Figure 32-26 on page 689 describes the Write operation.

Figure 32-26. Write Access Ordered by a Master

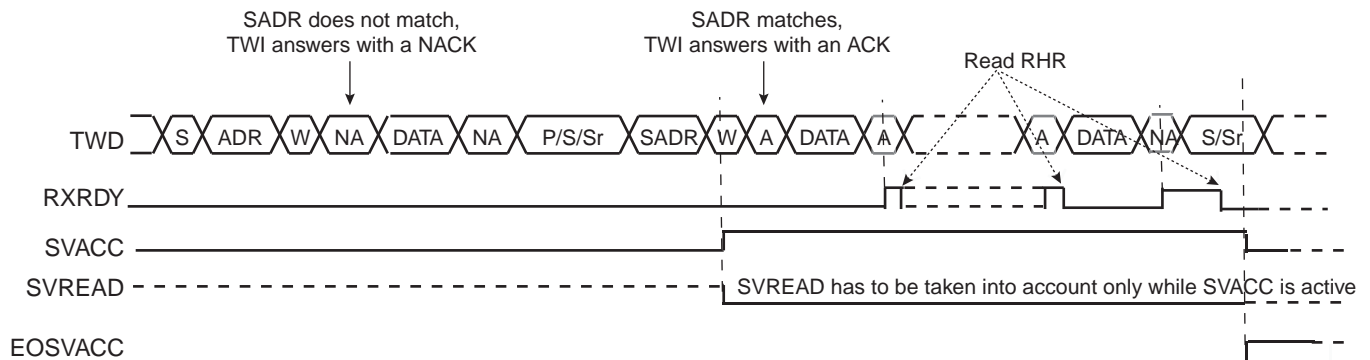

- Notes:
1. When SVACC is low, the state of SVREAD becomes irrelevant.
 2. RXRDY is set when data has been transmitted from the shift register to the TWI_RHR and reset when this data is read.

32.10.5.3 General Call

The general call is performed in order to change the address of the slave.

If a GENERAL CALL is detected, GACC is set.

After the detection of General Call, it is up to the programmer to decode the commands which come afterwards.

In case of a WRITE command, the programmer has to decode the programming sequence and program a new SADR if the programming sequence matches.

Figure 32-27 on page 690 describes the General Call access.

Figure 32-27. Master Performs a General Call

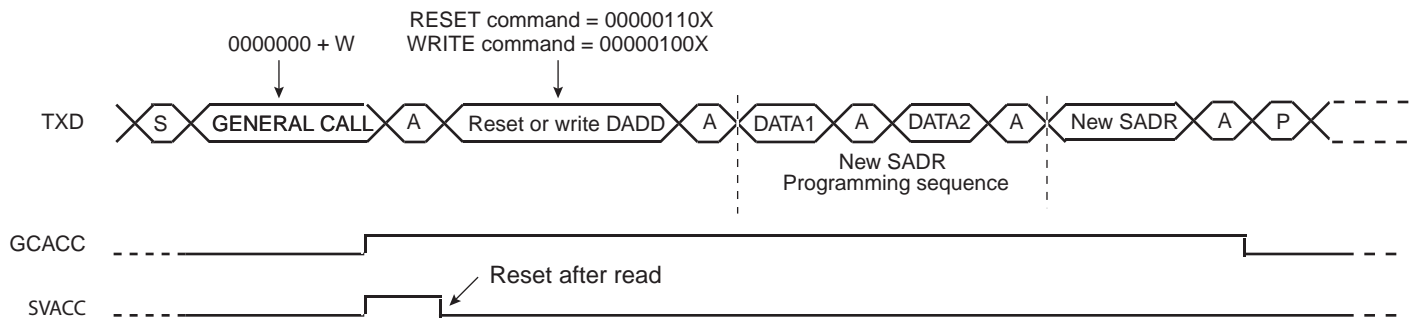

Note: This method allows the user to create an own programming sequence by choosing the programming bytes and the number of them. The programming sequence has to be provided to the master.

32.10.5.4 Clock Synchronization

In both read and write modes, it may happen that TWI_THR/TWI_RHR buffer is not filled /emptied before the emission/reception of a new character. In this case, to avoid sending/receiving undesired data, a clock stretching mechanism is implemented.

Clock Synchronization in Read Mode

The clock is tied low if the shift register is empty and if a STOP or REPEATED START condition was not detected. It is tied low until the shift register is loaded.

Figure 32-28 on page 691 describes the clock synchronization in Read mode.

Figure 32-28. Clock Synchronization in Read Mode

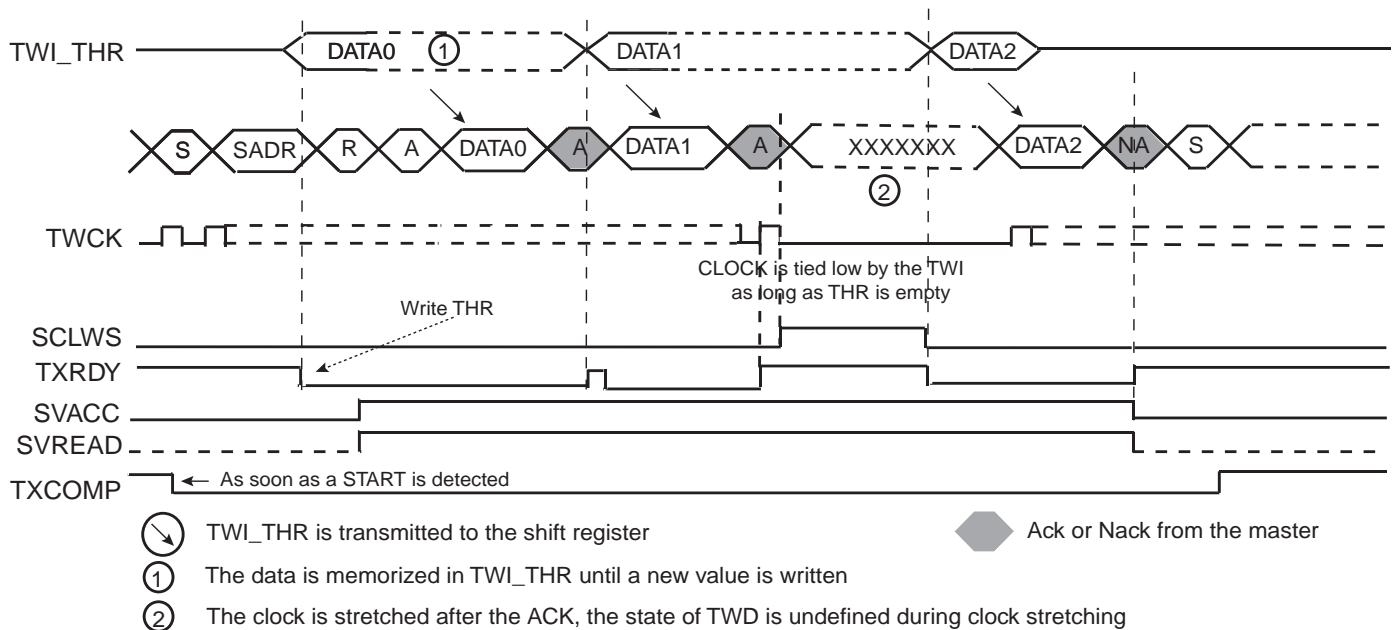

- Notes:
1. TXRDY is reset when data has been written in the TWI_THR to the shift register and set when this data has been acknowledged or non acknowledged.
 2. At the end of the read sequence, TXCOMP is set after a STOP or after a REPEATED_START + an address different from SADR.
 3. SCLWS is automatically set when the clock synchronization mechanism is started.

Clock Synchronization in Write Mode

The clock is tied low if the shift register and the TWI_RHR is full. If a STOP or REPEATED_START condition was not detected, it is tied low until TWI_RHR is read.

Figure 32-29 on page 692 describes the clock synchronization in Read mode.

Figure 32-29. Clock Synchronization in Write Mode

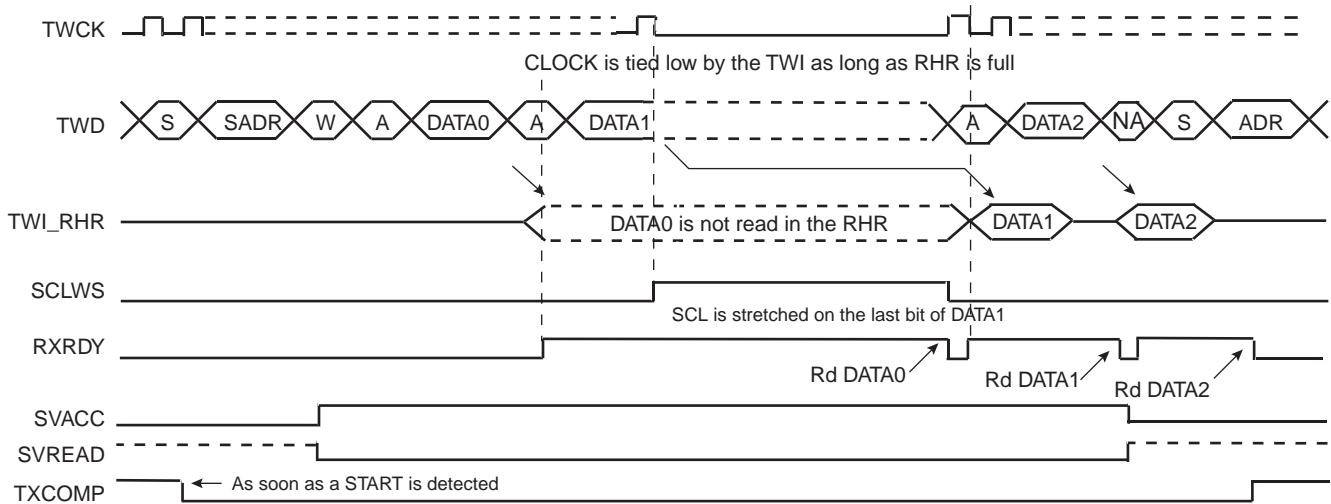

- Notes:
1. At the end of the read sequence, TXCOMP is set after a STOP or after a REPEATED_START + an address different from SADR.
 2. SCLWS is automatically set when the clock synchronization mechanism is started and automatically reset when the mechanism is finished.

32.10.5.5 Reversal after a Repeated Start

Reversal of Read to Write

The master initiates the communication by a read command and finishes it by a write command.

Figure 32-30 on page 693 describes the repeated start + reversal from Read to Write mode.

Figure 32-30. Repeated Start + Reversal from Read to Write Mode

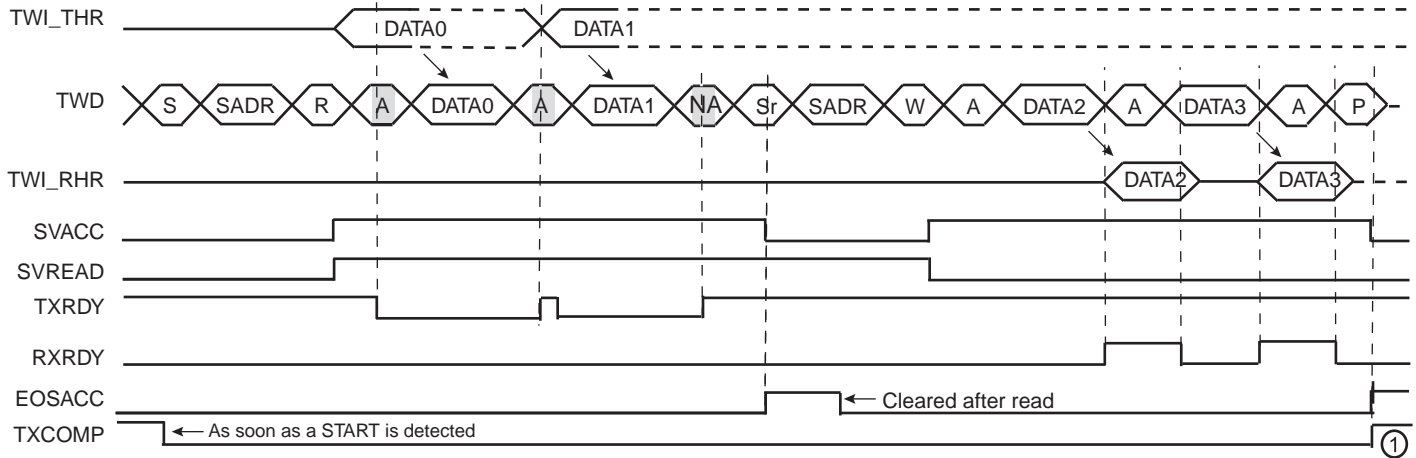

Reversal of Write to Read

The master initiates the communication by a write command and finishes it by a read command. Figure 32-31 on page 693 describes the repeated start + reversal from Write to Read mode.

Figure 32-31. Repeated Start + Reversal from Write to Read Mode

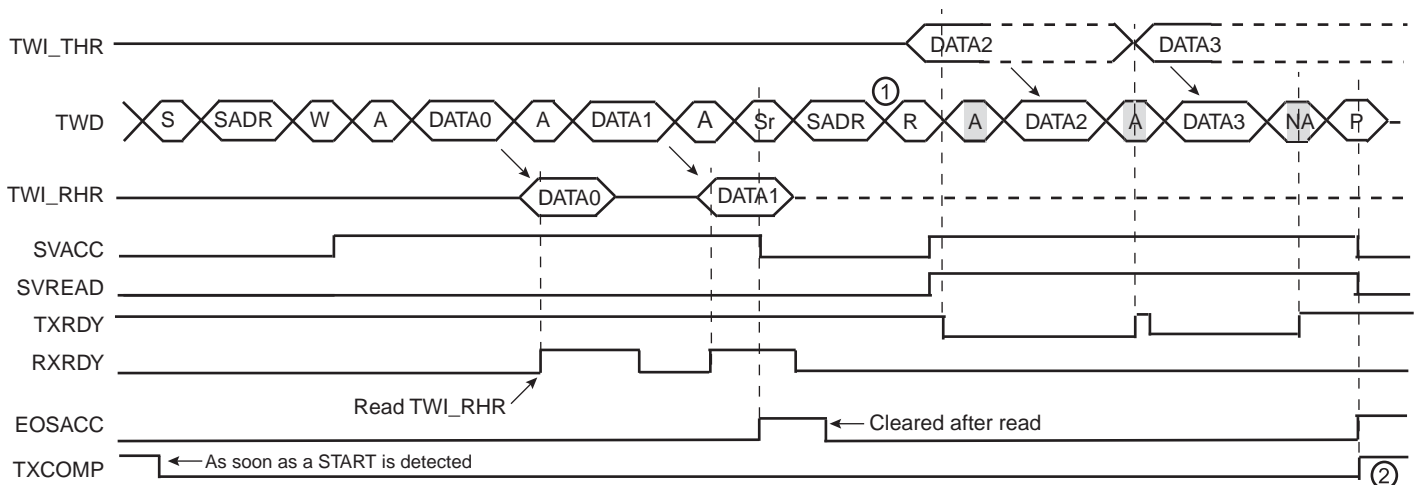

- Notes:
1. In this case, if TWI_THR has not been written at the end of the read command, the clock is automatically stretched before the ACK.
 2. TXCOMP is only set at the end of the transmission because after the repeated start, SADR is detected again.

32.10.6 Read Write Flowcharts

The flowchart shown in [Figure 32-32 on page 694](#) gives an example of read and write operations in Slave mode. A polling or interrupt method can be used to check the status bits. The interrupt method requires that the interrupt enable register (TWI_IER) be configured first.

Figure 32-32. Read Write Flowchart in Slave Mode

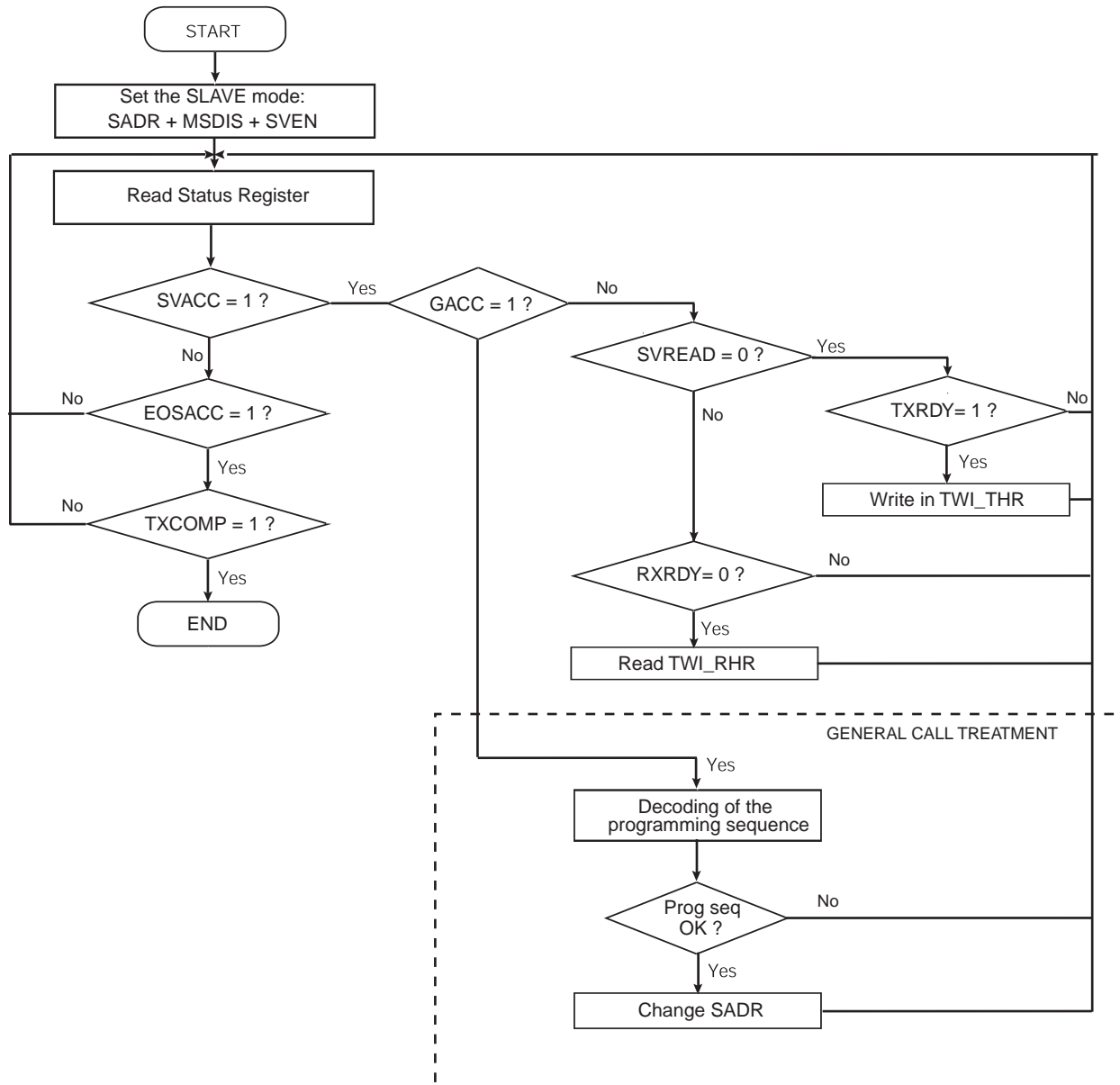

32.11 Two-wire Interface (TWI) User Interface

Table 32-6. Register Mapping

Offset	Register	Name	Access	Reset
0x00	Control Register	TWI_CR	Write-only	N / A
0x04	Master Mode Register	TWI_MMR	Read-write	0x00000000
0x08	Slave Mode Register	TWI_SMR	Read-write	0x00000000
0x0C	Internal Address Register	TWI_IADR	Read-write	0x00000000
0x10	Clock Waveform Generator Register	TWI_CWGR	Read-write	0x00000000
0x14 - 0x1C	Reserved	–	–	–
0x20	Status Register	TWI_SR	Read-only	0x0000F009
0x24	Interrupt Enable Register	TWI_IER	Write-only	N / A
0x28	Interrupt Disable Register	TWI_IDR	Write-only	N / A
0x2C	Interrupt Mask Register	TWI_IMR	Read-only	0x00000000
0x30	Receive Holding Register	TWI_RHR	Read-only	0x00000000
0x34	Transmit Holding Register	TWI_THR	Write-only	0x00000000
0xEC - 0xFC ⁽¹⁾	Reserved	–	–	–
0x100 - 0x124	Reserved for the PDC	–	–	–

Note: 1. All unlisted offset values are considered as “reserved”.

32.11.1 TWI Control Register

Name: TWI_CR

Address: 0x40018000 (0), 0x4001C000 (1)

Access: Write-only

Reset: 0x00000000

31	30	29	28	27	26	25	24
–	–	–	–	–	–	–	–
23	22	21	20	19	18	17	16
–	–	–	–	–	–	–	–
15	14	13	12	11	10	9	8
–	–	–	–	–	–	–	–
7	6	5	4	3	2	1	0
SWRST	QUICK	SVDIS	SVEN	MSDIS	MSEN	STOP	START

- **START: Send a START Condition**

0 = No effect.

1 = A frame beginning with a START bit is transmitted according to the features defined in the mode register.

This action is necessary when the TWI peripheral wants to read data from a slave. When configured in Master Mode with a write operation, a frame is sent as soon as the user writes a character in the Transmit Holding Register (TWI_THR).

- **STOP: Send a STOP Condition**

0 = No effect.

1 = STOP Condition is sent just after completing the current byte transmission in master read mode.

- In single data byte master read, the START and STOP must both be set.
- In multiple data bytes master read, the STOP must be set after the last data received but one.
- In master read mode, if a NACK bit is received, the STOP is automatically performed.
- In master data write operation, a STOP condition will be sent after the transmission of the current data is finished.

- **MSEN: TWI Master Mode Enabled**

0 = No effect.

1 = If MSDIS = 0, the master mode is enabled.

Note: Switching from Slave to Master mode is only permitted when TXCOMP = 1.

- **MSDIS: TWI Master Mode Disabled**

0 = No effect.

1 = The master mode is disabled, all pending data is transmitted. The shifter and holding characters (if it contains data) are transmitted in case of write operation. In read operation, the character being transferred must be completely received before disabling.

- **SVEN: TWI Slave Mode Enabled**

0 = No effect.

1 = If SVDIS = 0, the slave mode is enabled.

Note: Switching from Master to Slave mode is only permitted when TXCOMP = 1.

- **SVDIS: TWI Slave Mode Disabled**

0 = No effect.

1 = The slave mode is disabled. The shifter and holding characters (if it contains data) are transmitted in case of read operation. In write operation, the character being transferred must be completely received before disabling.

- **QUICK: SMBUS Quick Command**

0 = No effect.

1 = If Master mode is enabled, a SMBUS Quick Command is sent.

- **SWRST: Software Reset**

0 = No effect.

1 = Equivalent to a system reset.

32.11.2 TWI Master Mode Register

Name: TWI_MMR

Address: 0x40018004 (0), 0x4001C004 (1)

Access: Read-write

Reset: 0x00000000

31	30	29	28	27	26	25	24
–	–	–	–	–	–	–	–
23	22	21	20	19	18	17	16
–	DADR						
15	14	13	12	11	10	9	8
–	–	–	MREAD	–	–	IADRSZ	
7	6	5	4	3	2	1	0
–	–	–	–	–	–	–	–

- **IADRSZ: Internal Device Address Size**

Value	Name	Description
0	NONE	No internal device address
1	1_BYTE	One-byte internal device address
2	2_BYTE	Two-byte internal device address
3	3_BYTE	Three-byte internal device address

- **MREAD: Master Read Direction**

0 = Master write direction.

1 = Master read direction.

- **DADR: Device Address**

The device address is used to access slave devices in read or write mode. Those bits are only used in Master mode.

32.11.3 TWI Slave Mode Register

Name: TWI_SMR

Address: 0x40018008 (0), 0x4001C008 (1)

Access: Read-write

Reset: 0x00000000

31	30	29	28	27	26	25	24
–	–	–	–	–	–	–	–
23	22	21	20	19	18	17	16
–	SADR						
15	14	13	12	11	10	9	8
–	–	–	–	–	–		
7	6	5	4	3	2	1	0
–	–	–	–	–	–	–	–

- **SADR: Slave Address**

The slave device address is used in Slave mode in order to be accessed by master devices in read or write mode.

SADR must be programmed before enabling the Slave mode or after a general call. Writes at other times have no effect.



32.11.4 TWI Internal Address Register

Name: TWI_IADR

Address: 0x4001800C (0), 0x4001C00C (1)

Access: Read-write

Reset: 0x00000000

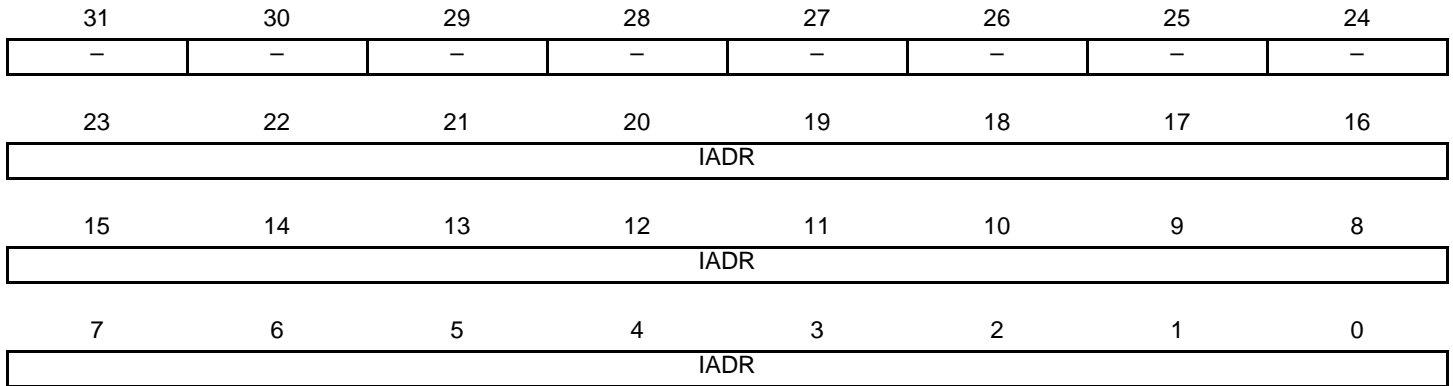

- **IADR: Internal Address**

0, 1, 2 or 3 bytes depending on IADRSZ.



32.11.5 TWI Clock Waveform Generator Register

Name: TWI_CWGR

Address: 0x40018010 (0), 0x4001C010 (1)

Access: Read-write

Reset: 0x00000000

31	30	29	28	27	26	25	24
–	–	–	–	–	–	–	–
23	22	21	20	19	18	17	16
						CKDIV	
15	14	13	12	11	10	9	8
CHDIV							
7	6	5	4	3	2	1	0
CLDIV							

TWI_CWGR is only used in Master mode.

- **CLDIV: Clock Low Divider**

The SCL low period is defined as follows:

$$T_{low} = ((CLDIV \times 2^{CKDIV}) + 4) \times T_{MCK}$$

- **CHDIV: Clock High Divider**

The SCL high period is defined as follows:

$$T_{high} = ((CHDIV \times 2^{CKDIV}) + 4) \times T_{MCK}$$

- **CKDIV: Clock Divider**

The CKDIV is used to increase both SCL high and low periods.

32.11.6 TWI Status Register

Name: TWI_SR

Address: 0x40018020 (0), 0x4001C020 (1)

Access: Read-only

Reset: 0x0000F009

31	30	29	28	27	26	25	24
–	–	–	–	–	–	–	–
23	22	21	20	19	18	17	16
–	–	–	–	–	–	–	–
15	14	13	12	11	10	9	8
TXBUFE	RXBUFF	ENDTX	ENDRX	EOSACC	SCLWS	ARBLST	NACK
7	6	5	4	3	2	1	0
–	OVRE	GACC	SVACC	SVREAD	TXRDY	RXRDY	TXCOMP

- **TXCOMP: Transmission Completed (automatically set / reset)**

TXCOMP used in Master mode:

0 = During the length of the current frame.

1 = When both holding and shifter registers are empty and STOP condition has been sent.

TXCOMP behavior in Master mode can be seen in [Figure 32-8 on page 674](#) and in [Figure 32-10 on page 675](#).

TXCOMP used in Slave mode:

0 = As soon as a Start is detected.

1 = After a Stop or a Repeated Start + an address different from SADR is detected.

TXCOMP behavior in Slave mode can be seen in [Figure 32-28 on page 691](#), [Figure 32-29 on page 692](#), [Figure 32-30 on page 693](#) and [Figure 32-31 on page 693](#).

- **RXRDY: Receive Holding Register Ready (automatically set / reset)**

0 = No character has been received since the last TWI_RHR read operation.

1 = A byte has been received in the TWI_RHR since the last read.

RXRDY behavior in Master mode can be seen in [Figure 32-10 on page 675](#).

RXRDY behavior in Slave mode can be seen in [Figure 32-26 on page 689](#), [Figure 32-29 on page 692](#), [Figure 32-30 on page 693](#) and [Figure 32-31 on page 693](#).

- **TXRDY: Transmit Holding Register Ready (automatically set / reset)**

TXRDY used in Master mode:

0 = The transmit holding register has not been transferred into shift register. Set to 0 when writing into TWI_THR register.

1 = As soon as a data byte is transferred from TWI_THR to internal shifter or if a NACK error is detected, TXRDY is set at the same time as TXCOMP and NACK. TXRDY is also set when MSEN is set (enable TWI).

TXRDY behavior in Master mode can be seen in [Figure 32-8 on page 674](#).

TXRDY used in Slave mode:

0 = As soon as data is written in the TWI_THR, until this data has been transmitted and acknowledged (ACK or NACK).

1 = It indicates that the TWI_THR is empty and that data has been transmitted and acknowledged.

If TXRDY is high and if a NACK has been detected, the transmission will be stopped. Thus when TRDY = NACK = 1, the programmer must not fill TWI_THR to avoid losing it.

TXRDY behavior in Slave mode can be seen in [Figure 32-25 on page 689](#), [Figure 32-28 on page 691](#), [Figure 32-30 on page 693](#) and [Figure 32-31 on page 693](#).

- **SVREAD: Slave Read (automatically set / reset)**

This bit is only used in Slave mode. When SVACC is low (no Slave access has been detected) SVREAD is irrelevant.

0 = Indicates that a write access is performed by a Master.

1 = Indicates that a read access is performed by a Master.

SVREAD behavior can be seen in [Figure 32-25 on page 689](#), [Figure 32-26 on page 689](#), [Figure 32-30 on page 693](#) and [Figure 32-31 on page 693](#).

- **SVACC: Slave Access (automatically set / reset)**

This bit is only used in Slave mode.

0 = TWI is not addressed. SVACC is automatically cleared after a NACK or a STOP condition is detected.

1 = Indicates that the address decoding sequence has matched (A Master has sent SADR). SVACC remains high until a NACK or a STOP condition is detected.

SVACC behavior can be seen in [Figure 32-25 on page 689](#), [Figure 32-26 on page 689](#), [Figure 32-30 on page 693](#) and [Figure 32-31 on page 693](#).

- **GACC: General Call Access (clear on read)**

This bit is only used in Slave mode.

0 = No General Call has been detected.

1 = A General Call has been detected. After the detection of General Call, if need be, the programmer may acknowledge this access and decode the following bytes and respond according to the value of the bytes.

GACC behavior can be seen in [Figure 32-27 on page 690](#).

- **OVRE: Overrun Error (clear on read)**

This bit is only used in Master mode.

0 = TWI_RHR has not been loaded while RXRDY was set

1 = TWI_RHR has been loaded while RXRDY was set. Reset by read in TWI_SR when TXCOMP is set.

- **NACK: Not Acknowledged (clear on read)**

NACK used in Master mode:

0 = Each data byte has been correctly received by the far-end side TWI slave component.

1 = A data byte has not been acknowledged by the slave component. Set at the same time as TXCOMP.

NACK used in Slave Read mode:

0 = Each data byte has been correctly received by the Master.

1 = In read mode, a data byte has not been acknowledged by the Master. When NACK is set the programmer must not fill TWI_THR even if TXRDY is set, because it means that the Master will stop the data transfer or re initiate it.

Note that in Slave Write mode all data are acknowledged by the TWI.

- **ARBLST: Arbitration Lost (clear on read)**

This bit is only used in Master mode.

0: Arbitration won.

1: Arbitration lost. Another master of the TWI bus has won the multi-master arbitration. TXCOMP is set at the same time.

- **SCLWS: Clock Wait State (automatically set / reset)**

This bit is only used in Slave mode.

0 = The clock is not stretched.

1 = The clock is stretched. TWI_THR / TWI_RHR buffer is not filled / emptied before the emission / reception of a new character.

SCLWS behavior can be seen in [Figure 32-28 on page 691](#) and [Figure 32-29 on page 692](#).

- **EOSACC: End Of Slave Access (clear on read)**

This bit is only used in Slave mode.

0 = A slave access is being performing.

1 = The Slave Access is finished. End Of Slave Access is automatically set as soon as SVACC is reset.

EOSACC behavior can be seen in [Figure 32-30 on page 693](#) and [Figure 32-31 on page 693](#)

- **ENDRX: End of RX buffer**

This bit is only used in Master mode.

0 = The Receive Counter Register has not reached 0 since the last write in TWI_RCR or TWI_RNCR.

1 = The Receive Counter Register has reached 0 since the last write in TWI_RCR or TWI_RNCR.

- **ENDTX: End of TX buffer**

This bit is only used in Master mode.

0 = The Transmit Counter Register has not reached 0 since the last write in TWI_TCR or TWI_TNCR.

1 = The Transmit Counter Register has reached 0 since the last write in TWI_TCR or TWI_TNCR.

- **RXBUFF: RX Buffer Full**

This bit is only used in Master mode.

0 = TWI_RCR or TWI_RNCR have a value other than 0.

1 = Both TWI_RCR and TWI_RNCR have a value of 0.

- **TXBUFE: TX Buffer Empty**

This bit is only used in Master mode.

0 = TWI_TCR or TWI_TNCR have a value other than 0.

1 = Both TWI_TCR and TWI_TNCR have a value of 0.

32.11.7 TWI Interrupt Enable Register

Name: TWI_IER

Address: 0x40018024 (0), 0x4001C024 (1)

Access: Write-only

Reset: 0x00000000

31	30	29	28	27	26	25	24
–	–	–	–	–	–	–	–
23	22	21	20	19	18	17	16
–	–	–	–	–	–	–	–
15	14	13	12	11	10	9	8
TXBUFE	RXBUFF	ENDTX	ENDRX	EOSACC	SCL_WS	ARBLST	NACK
7	6	5	4	3	2	1	0
–	OVRE	GACC	SVACC	–	TXRDY	RXRDY	TXCOMP

- **TXCOMP:** Transmission Completed Interrupt Enable
- **RXRDY:** Receive Holding Register Ready Interrupt Enable
- **TXRDY:** Transmit Holding Register Ready Interrupt Enable
- **SVACC:** Slave Access Interrupt Enable
- **GACC:** General Call Access Interrupt Enable
- **OVRE:** Overrun Error Interrupt Enable
- **NACK:** Not Acknowledge Interrupt Enable
- **ARBLST:** Arbitration Lost Interrupt Enable
- **SCL_WS:** Clock Wait State Interrupt Enable
- **EOSACC:** End Of Slave Access Interrupt Enable
- **ENDRX:** End of Receive Buffer Interrupt Enable
- **ENDTX:** End of Transmit Buffer Interrupt Enable
- **RXBUFF:** Receive Buffer Full Interrupt Enable
- **TXBUFE:** Transmit Buffer Empty Interrupt Enable

0 = No effect.

1 = Enables the corresponding interrupt.

32.11.8 TWI Interrupt Disable Register

Name: TWI_IDR

Address: 0x40018028 (0), 0x4001C028 (1)

Access: Write-only

Reset: 0x00000000

31	30	29	28	27	26	25	24
–	–	–	–	–	–	–	–
23	22	21	20	19	18	17	16
–	–	–	–	–	–	–	–
15	14	13	12	11	10	9	8
TXBUFE	RXBUFF	ENDTX	ENDRX	EOSACC	SCL_WS	ARBLST	NACK
7	6	5	4	3	2	1	0
–	OVRE	GACC	SVACC	–	TXRDY	RXRDY	TXCOMP

- **TXCOMP:** Transmission Completed Interrupt Disable
- **RXRDY:** Receive Holding Register Ready Interrupt Disable
- **TXRDY:** Transmit Holding Register Ready Interrupt Disable
- **SVACC:** Slave Access Interrupt Disable
- **GACC:** General Call Access Interrupt Disable
- **OVRE:** Overrun Error Interrupt Disable
- **NACK:** Not Acknowledge Interrupt Disable
- **ARBLST:** Arbitration Lost Interrupt Disable
- **SCL_WS:** Clock Wait State Interrupt Disable
- **EOSACC:** End Of Slave Access Interrupt Disable
- **ENDRX:** End of Receive Buffer Interrupt Disable
- **ENDTX:** End of Transmit Buffer Interrupt Disable
- **RXBUFF:** Receive Buffer Full Interrupt Disable
- **TXBUFE:** Transmit Buffer Empty Interrupt Disable

0 = No effect.

1 = Disables the corresponding interrupt.

32.11.9 TWI Interrupt Mask Register

Name: TWI_IMR

Address: 0x4001802C (0), 0x4001C02C (1)

Access: Read-only

Reset: 0x00000000

31	30	29	28	27	26	25	24
–	–	–	–	–	–	–	–
23	22	21	20	19	18	17	16
–	–	–	–	–	–	–	–
15	14	13	12	11	10	9	8
TXBUFE	RXBUFF	ENDTX	ENDRX	EOSACC	SCL_WS	ARBLST	NACK
7	6	5	4	3	2	1	0
–	OVRE	GACC	SVACC	–	TXRDY	RXRDY	TXCOMP

- **TXCOMP:** Transmission Completed Interrupt Mask
- **RXRDY:** Receive Holding Register Ready Interrupt Mask
- **TXRDY:** Transmit Holding Register Ready Interrupt Mask
- **SVACC:** Slave Access Interrupt Mask
- **GACC:** General Call Access Interrupt Mask
- **OVRE:** Overrun Error Interrupt Mask
- **NACK:** Not Acknowledge Interrupt Mask
- **ARBLST:** Arbitration Lost Interrupt Mask
- **SCL_WS:** Clock Wait State Interrupt Mask
- **EOSACC:** End Of Slave Access Interrupt Mask
- **ENDRX:** End of Receive Buffer Interrupt Mask
- **ENDTX:** End of Transmit Buffer Interrupt Mask
- **RXBUFF:** Receive Buffer Full Interrupt Mask
- **TXBUFE:** Transmit Buffer Empty Interrupt Mask

0 = The corresponding interrupt is disabled.

1 = The corresponding interrupt is enabled.



32.11.10 TWI Receive Holding Register

Name: TWI_RHR

Address: 0x40018030 (0), 0x4001C030 (1)

Access: Read-only

Reset: 0x00000000

31	30	29	28	27	26	25	24
-	-	-	-	-	-	-	-
23	22	21	20	19	18	17	16
-	-	-	-	-	-	-	-
15	14	13	12	11	10	9	8
-	-	-	-	-	-	-	-
7	6	5	4	3	2	1	0
RXDATA							

- RXDATA: Master or Slave Receive Holding Data

32.11.11 TWI Transmit Holding Register

Name: TWI_THR

Address: 0x40018034 (0), 0x4001C034 (1)

Access: Read-write

Reset: 0x00000000

31	30	29	28	27	26	25	24
-	-	-	-	-	-	-	-
23	22	21	20	19	18	17	16
-	-	-	-	-	-	-	-
15	14	13	12	11	10	9	8
-	-	-	-	-	-	-	-
7	6	5	4	3	2	1	0
TXDATA							

- TXDATA: Master or Slave Transmit Holding Data



33. Universal Asynchronous Receiver Transmitter (UART)

33.1 Description

The Universal Asynchronous Receiver Transmitter (UART) features a two-pin UART that can be used for communication and trace purposes and offers an ideal medium for in-situ programming solutions. Moreover, the association with two peripheral DMA controller (PDC) channels permits packet handling for these tasks with processor time reduced to a minimum.

33.2 Embedded Characteristics

- Two-pin UART
 - Independent receiver and transmitter with a common programmable Baud Rate Generator
 - Even, Odd, Mark or Space Parity Generation
 - Parity, Framing and Overrun Error Detection
 - Automatic Echo, Local Loopback and Remote Loopback Channel Modes
 - Support for two PDC channels with connection to receiver and transmitter

33.3 Block Diagram

Figure 33-1. UART Functional Block Diagram

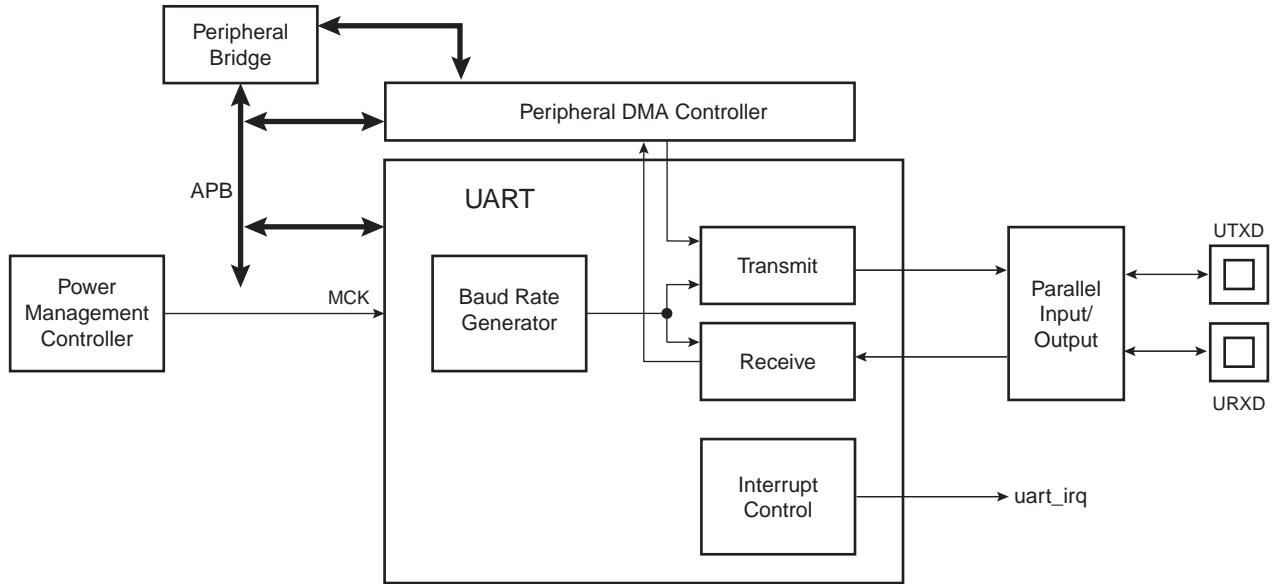

Table 33-1. UART Pin Description

Pin Name	Description	Type
URXD	UART Receive Data	Input
UTXD	UART Transmit Data	Output

33.4 Product Dependencies

33.4.1 I/O Lines

The UART pins are multiplexed with PIO lines. The programmer must first configure the corresponding PIO Controller to enable I/O line operations of the UART.

Table 33-2. I/O Lines

Instance	Signal	I/O Line	Peripheral
UART0	URXD0	PA9	A
UART0	UTXD0	PA10	A
UART1	URXD1	PB2	A
UART1	UTXD1	PB3	A

33.4.2 Power Management

The UART clock is controllable through the Power Management Controller. In this case, the programmer must first configure the PMC to enable the UART clock. Usually, the peripheral identifier used for this purpose is 1.

33.4.3 Interrupt Source

The UART interrupt line is connected to one of the interrupt sources of the Nested Vectored Interrupt Controller (NVIC). Interrupt handling requires programming of the NVIC before configuring the UART.

33.5 UART Operations

The UART operates in asynchronous mode only and supports only 8-bit character handling (with parity). It has no clock pin.

The UART is made up of a receiver and a transmitter that operate independently, and a common baud rate generator. Receiver timeout and transmitter time guard are not implemented. However, all the implemented features are compatible with those of a standard USART.

33.5.1 Baud Rate Generator

The baud rate generator provides the bit period clock named baud rate clock to both the receiver and the transmitter.

The baud rate clock is the master clock divided by 16 times the value (CD) written in UART_BRGR (Baud Rate Generator Register). If UART_BRGR is set to 0, the baud rate clock is disabled and the UART remains inactive. The maximum allowable baud rate is Master Clock divided by 16. The minimum allowable baud rate is Master Clock divided by (16 x 65536).

$$\text{Baud Rate} = \frac{\text{MCK}}{16 \times \text{CD}}$$

Figure 33-2. Baud Rate Generator

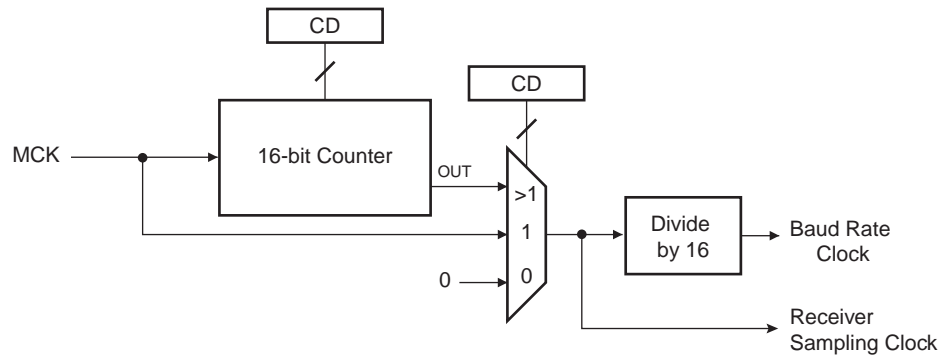

33.5.2 Receiver

33.5.2.1 Receiver Reset, Enable and Disable

After device reset, the UART receiver is disabled and must be enabled before being used. The receiver can be enabled by writing the control register `UART_CR` with the bit `RXEN` at 1. At this command, the receiver starts looking for a start bit.

The programmer can disable the receiver by writing `UART_CR` with the bit `RXDIS` at 1. If the receiver is waiting for a start bit, it is immediately stopped. However, if the receiver has already detected a start bit and is receiving the data, it waits for the stop bit before actually stopping its operation.

The programmer can also put the receiver in its reset state by writing `UART_CR` with the bit `RSTRX` at 1. In doing so, the receiver immediately stops its current operations and is disabled, whatever its current state. If `RSTRX` is applied when data is being processed, this data is lost.

33.5.2.2 Start Detection and Data Sampling

The UART only supports asynchronous operations, and this affects only its receiver. The UART receiver detects the start of a received character by sampling the `URXD` signal until it detects a valid start bit. A low level (space) on `URXD` is interpreted as a valid start bit if it is detected for more than 7 cycles of the sampling clock, which is 16 times the baud rate. Hence, a space that is longer than $7/16$ of the bit period is detected as a valid start bit. A space which is $7/16$ of a bit period or shorter is ignored and the receiver continues to wait for a valid start bit.

When a valid start bit has been detected, the receiver samples the `URXD` at the theoretical midpoint of each bit. It is assumed that each bit lasts 16 cycles of the sampling clock (1-bit period) so the bit sampling point is eight cycles (0.5-bit period) after the start of the bit. The first sampling point is therefore 24 cycles (1.5-bit periods) after the falling edge of the start bit was detected.

Each subsequent bit is sampled 16 cycles (1-bit period) after the previous one.

Figure 33-3. Start Bit Detection

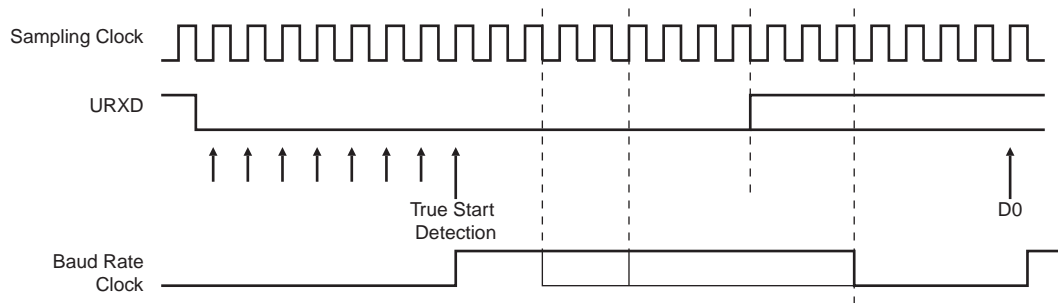
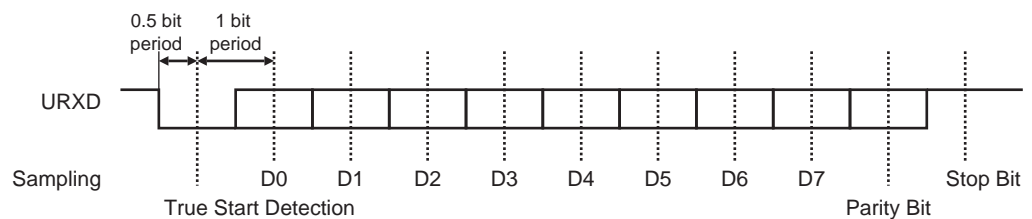

Figure 33-4. Character Reception

Example: 8-bit, parity enabled 1 stop



33.5.2.3 Receiver Ready

When a complete character is received, it is transferred to the UART_RHR and the RXRDY status bit in UART_SR (Status Register) is set. The bit RXRDY is automatically cleared when the receive holding register UART_RHR is read.

Figure 33-5. Receiver Ready

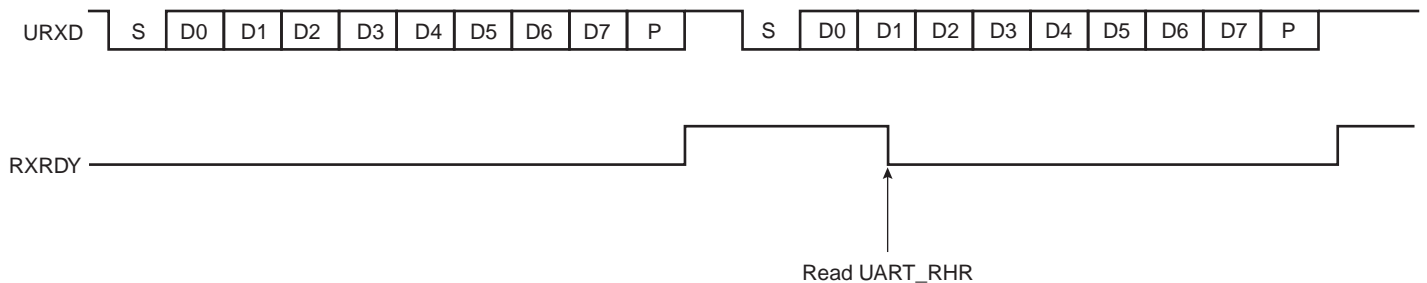

33.5.2.4 Receiver Overrun

If UART_RHR has not been read by the software (or the Peripheral Data Controller or DMA Controller) since the last transfer, the RXRDY bit is still set and a new character is received, the OVRE status bit in UART_SR is set. OVRE is cleared when the software writes the control register UART_CR with the bit RSTSTA (Reset Status) at 1.

Figure 33-6. Receiver Overrun

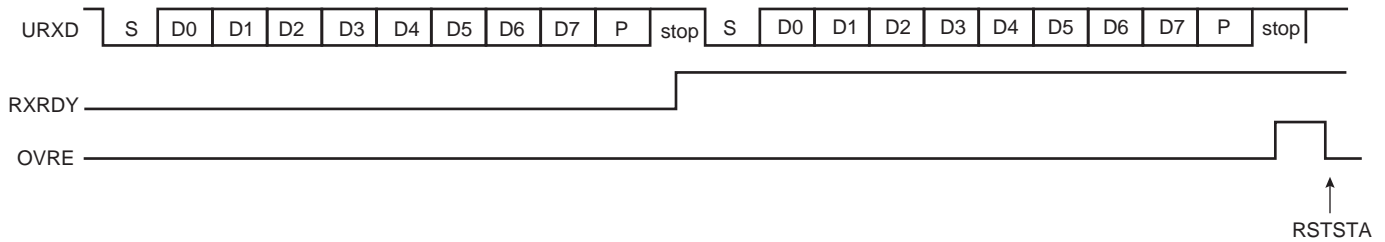

33.5.2.5 Parity Error

Each time a character is received, the receiver calculates the parity of the received data bits, in accordance with the field PAR in UART_MR. It then compares the result with the received parity bit. If different, the parity error bit PARE in UART_SR is set at the same time the RXRDY is set. The parity bit is cleared when the control register UART_CR is written with the bit RSTSTA (Reset Status) at 1. If a new character is received before the reset status command is written, the PARE bit remains at 1.

Figure 33-7. Parity Error

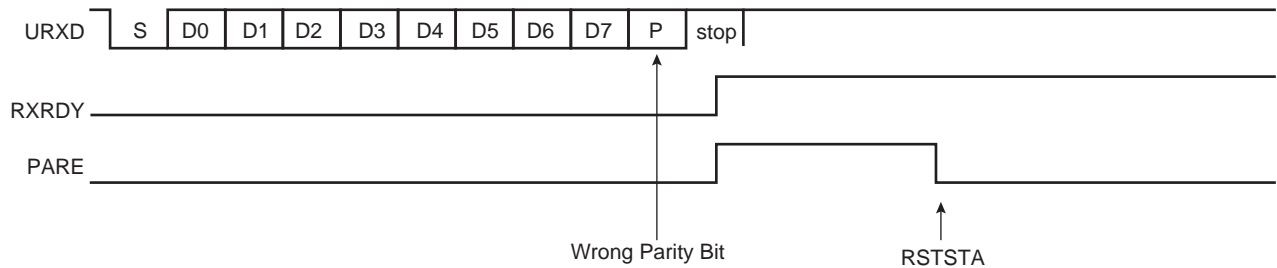

33.5.2.6 Receiver Framing Error

When a start bit is detected, it generates a character reception when all the data bits have been sampled. The stop bit is also sampled and when it is detected at 0, the FRAME (Framing Error) bit in UART_SR is set at the same time the RXRDY bit is set. The FRAME bit remains high until the control register UART_CR is written with the bit RSTSTA at 1.

Figure 33-8. Receiver Framing Error

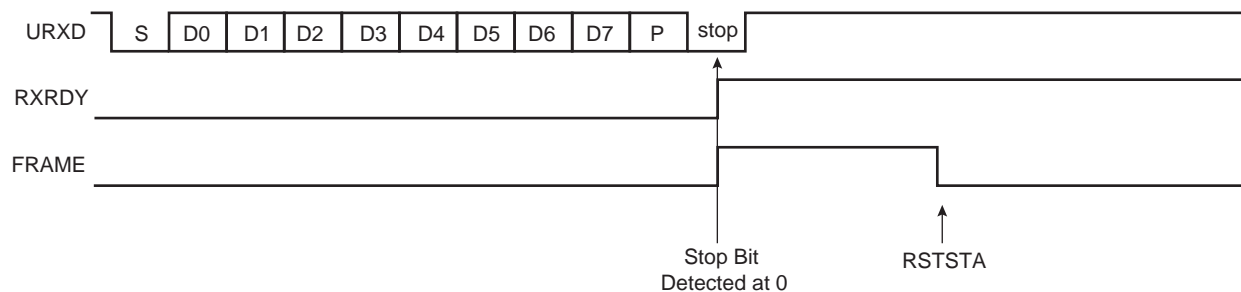

33.5.3 Transmitter

33.5.3.1 Transmitter Reset, Enable and Disable

After device reset, the UART transmitter is disabled and it must be enabled before being used. The transmitter is enabled by writing the control register `UART_CR` with the bit `TXEN` at 1. From this command, the transmitter waits for a character to be written in the Transmit Holding Register (`UART_THR`) before actually starting the transmission.

The programmer can disable the transmitter by writing `UART_CR` with the bit `TXDIS` at 1. If the transmitter is not operating, it is immediately stopped. However, if a character is being processed into the Shift Register and/or a character has been written in the Transmit Holding Register, the characters are completed before the transmitter is actually stopped.

The programmer can also put the transmitter in its reset state by writing the `UART_CR` with the bit `RSTTX` at 1. This immediately stops the transmitter, whether or not it is processing characters.

33.5.3.2 Transmit Format

The UART transmitter drives the pin `UTXD` at the baud rate clock speed. The line is driven depending on the format defined in the Mode Register and the data stored in the Shift Register. One start bit at level 0, then the 8 data bits, from the lowest to the highest bit, one optional parity bit and one stop bit at 1 are consecutively shifted out as shown in the following figure. The field `PARE` in the mode register `UART_MR` defines whether or not a parity bit is shifted out. When a parity bit is enabled, it can be selected between an odd parity, an even parity, or a fixed space or mark bit.

Figure 33-9. Character Transmission

Example: Parity enabled

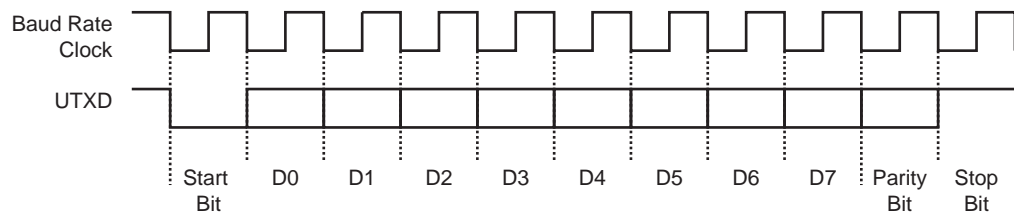

33.5.3.3 Transmitter Control

When the transmitter is enabled, the bit `TXRDY` (Transmitter Ready) is set in the status register `UART_SR`. The transmission starts when the programmer writes in the Transmit Holding Register (`UART_THR`), and after the written character is transferred from `UART_THR` to the Shift Register. The `TXRDY` bit remains high until a second character is written in `UART_THR`. As soon as the first character is completed, the last character written in `UART_THR` is transferred into the shift register and `TXRDY` rises again, showing that the holding register is empty.

When both the Shift Register and `UART_THR` are empty, i.e., all the characters written in `UART_THR` have been processed, the `TXEMPTY` bit rises after the last stop bit has been completed.

Figure 33-10. Transmitter Control

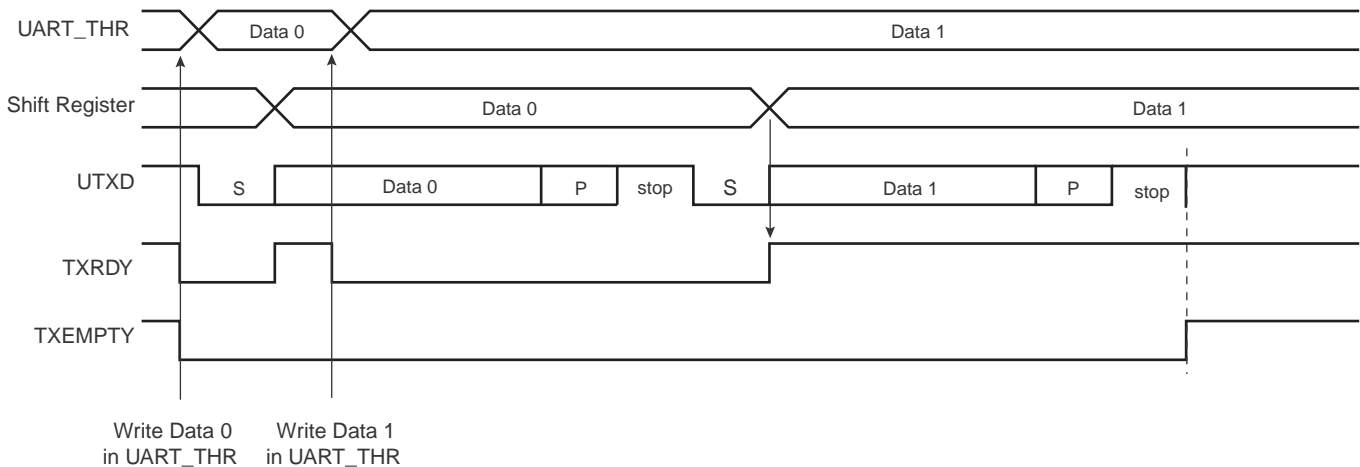

33.5.4 Peripheral DMA Controller

Both the receiver and the transmitter of the UART are connected to a Peripheral DMA Controller (PDC) channel.

The peripheral data controller channels are programmed via registers that are mapped within the UART user interface from the offset 0x100. The status bits are reported in the UART status register (UART_SR) and can generate an interrupt.

The RXRDY bit triggers the PDC channel data transfer of the receiver. This results in a read of the data in UART_RHR. The TXRDY bit triggers the PDC channel data transfer of the transmitter. This results in a write of data in UART_THR.

33.5.5 Test Modes

The UART supports three test modes. These modes of operation are programmed by using the field CHMODE (Channel Mode) in the mode register (UART_MR).

The Automatic Echo mode allows bit-by-bit retransmission. When a bit is received on the URXD line, it is sent to the UTXD line. The transmitter operates normally, but has no effect on the UTXD line.

The Local Loopback mode allows the transmitted characters to be received. UTXD and URXD pins are not used and the output of the transmitter is internally connected to the input of the receiver. The URXD pin level has no effect and the UTXD line is held high, as in idle state.

The Remote Loopback mode directly connects the URXD pin to the UTXD line. The transmitter and the receiver are disabled and have no effect. This mode allows a bit-by-bit retransmission.

Figure 33-11. Test Modes

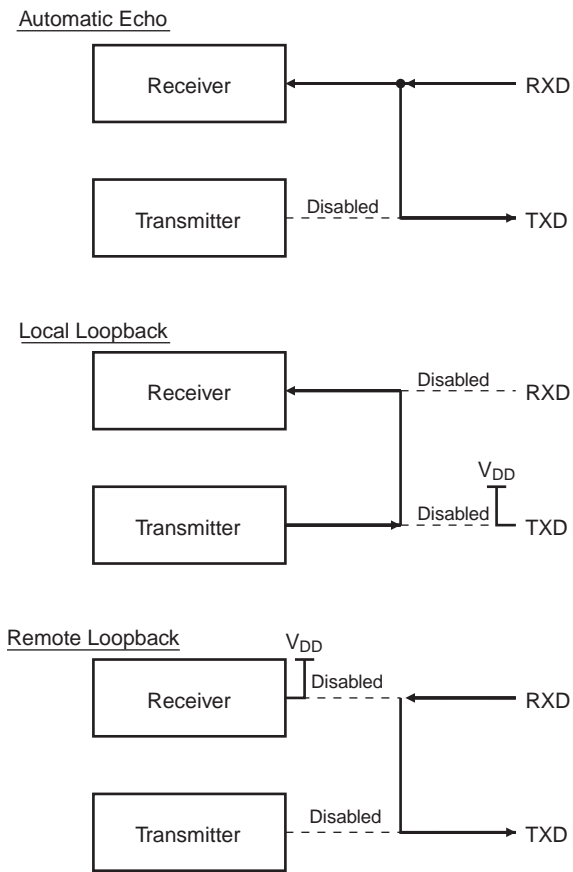

33.6 Universal Asynchronous Receiver Transmitter (UART) User Interface

Table 33-3. Register Mapping

Offset	Register	Name	Access	Reset
0x0000	Control Register	UART_CR	Write-only	–
0x0004	Mode Register	UART_MR	Read-write	0x0
0x0008	Interrupt Enable Register	UART_IER	Write-only	–
0x000C	Interrupt Disable Register	UART_IDR	Write-only	–
0x0010	Interrupt Mask Register	UART_IMR	Read-only	0x0
0x0014	Status Register	UART_SR	Read-only	–
0x0018	Receive Holding Register	UART_RHR	Read-only	0x0
0x001C	Transmit Holding Register	UART_THR	Write-only	–
0x0020	Baud Rate Generator Register	UART_BRGR	Read-write	0x0
0x0024 - 0x003C	Reserved	–	–	–
0x004C - 0x00FC	Reserved	–	–	–
0x0100 - 0x0124	PDC Area	–	–	–

33.6.1 UART Control Register

Name: UART_CR
Address: 0x400E0600 (0), 0x400E0800 (1)
Access: Write-only

31	30	29	28	27	26	25	24
–	–	–	–	–	–	–	–
23	22	21	20	19	18	17	16
–	–	–	–	–	–	–	–
15	14	13	12	11	10	9	8
–	–	–	–	–	–	–	RSTSTA
7	6	5	4	3	2	1	0
TXDIS	TXEN	RXDIS	RXEN	RSTTX	RSTRX	–	–

- **RSTRX: Reset Receiver**

0 = No effect.

1 = The receiver logic is reset and disabled. If a character is being received, the reception is aborted.

- **RSTTX: Reset Transmitter**

0 = No effect.

1 = The transmitter logic is reset and disabled. If a character is being transmitted, the transmission is aborted.

- **RXEN: Receiver Enable**

0 = No effect.

1 = The receiver is enabled if RXDIS is 0.

- **RXDIS: Receiver Disable**

0 = No effect.

1 = The receiver is disabled. If a character is being processed and RSTRX is not set, the character is completed before the receiver is stopped.

- **TXEN: Transmitter Enable**

0 = No effect.

1 = The transmitter is enabled if TXDIS is 0.

- **TXDIS: Transmitter Disable**

0 = No effect.

1 = The transmitter is disabled. If a character is being processed and a character has been written in the UART_THR and RSTTX is not set, both characters are completed before the transmitter is stopped.

- **RSTSTA: Reset Status Bits**

0 = No effect.

1 = Resets the status bits PARE, FRAME and OVRE in the UART_SR.

33.6.2 UART Mode Register

Name: UART_MR

Address: 0x400E0604 (0), 0x400E0804 (1)

Access: Read-write

31	30	29	28	27	26	25	24
–	–	–	–	–	–	–	–
23	22	21	20	19	18	17	16
–	–	–	–	–	–	–	–
15	14	13	12	11	10	9	8
CHMODE		–	–	PAR		–	
7	6	5	4	3	2	1	0
–	–	–	–	–	–	–	–

- **PAR: Parity Type**

Value	Name	Description
0	EVEN	Even parity
1	ODD	Odd parity
2	SPACE	Space: parity forced to 0
3	MARK	Mark: parity forced to 1
4	NO	No parity

- **CHMODE: Channel Mode**

Value	Name	Description
0	NORMAL	Normal Mode
1	AUTOMATIC	Automatic Echo
2	LOCAL_LOOPBACK	Local Loopback
3	REMOTE_LOOPBACK	Remote Loopback

33.6.3 UART Interrupt Enable Register

Name: UART_IER

Address: 0x400E0608 (0), 0x400E0808 (1)

Access: Write-only

31	30	29	28	27	26	25	24
–	–	–	–	–	–	–	–
23	22	21	20	19	18	17	16
–	–	–	–	–	–	–	–
15	14	13	12	11	10	9	8
–	–	–	RXBUFF	TXBUFE	–	TXEMPTY	–
7	6	5	4	3	2	1	0
PARE	FRAME	OVRE	ENDTX	ENDRX	–	TXRDY	RXRDY

- **RXRDY:** Enable RXRDY Interrupt
- **TXRDY:** Enable TXRDY Interrupt
- **ENDRX:** Enable End of Receive Transfer Interrupt
- **ENDTX:** Enable End of Transmit Interrupt
- **OVRE:** Enable Overrun Error Interrupt
- **FRAME:** Enable Framing Error Interrupt
- **PARE:** Enable Parity Error Interrupt
- **TXEMPTY:** Enable TXEMPTY Interrupt
- **TXBUFE:** Enable Buffer Empty Interrupt
- **RXBUFF:** Enable Buffer Full Interrupt

0 = No effect.

1 = Enables the corresponding interrupt.

33.6.4 UART Interrupt Disable Register

Name: UART_IDR
Address: 0x400E060C (0), 0x400E080C (1)
Access: Write-only

31	30	29	28	27	26	25	24
–	–	–	–	–	–	–	–
23	22	21	20	19	18	17	16
–	–	–	–	–	–	–	–
15	14	13	12	11	10	9	8
–	–	–	RXBUFF	TXBUFE	–	TXEMPTY	–
7	6	5	4	3	2	1	0
PARE	FRAME	OVRE	ENDTX	ENDRX	–	TXRDY	RXRDY

- **RXRDY: Disable RXRDY Interrupt**
- **TXRDY: Disable TXRDY Interrupt**
- **ENDRX: Disable End of Receive Transfer Interrupt**
- **ENDTX: Disable End of Transmit Interrupt**
- **OVRE: Disable Overrun Error Interrupt**
- **FRAME: Disable Framing Error Interrupt**
- **PARE: Disable Parity Error Interrupt**
- **TXEMPTY: Disable TXEMPTY Interrupt**
- **TXBUFE: Disable Buffer Empty Interrupt**
- **RXBUFF: Disable Buffer Full Interrupt**

0 = No effect.

1 = Disables the corresponding interrupt.

33.6.5 UART Interrupt Mask Register

Name: UART_IMR

Address: 0x400E0610 (0), 0x400E0810 (1)

Access: Read-only

31	30	29	28	27	26	25	24
–	–	–	–	–	–	–	–
23	22	21	20	19	18	17	16
–	–	–	–	–	–	–	–
15	14	13	12	11	10	9	8
–	–	–	RXBUFF	TXBUFE	–	TXEMPTY	–
7	6	5	4	3	2	1	0
PARE	FRAME	OVRE	ENDTX	ENDRX	–	TXRDY	RXRDY

- **RXRDY: Mask RXRDY Interrupt**
- **TXRDY: Disable TXRDY Interrupt**
- **ENDRX: Mask End of Receive Transfer Interrupt**
- **ENDTX: Mask End of Transmit Interrupt**
- **OVRE: Mask Overrun Error Interrupt**
- **FRAME: Mask Framing Error Interrupt**
- **PARE: Mask Parity Error Interrupt**
- **TXEMPTY: Mask TXEMPTY Interrupt**
- **TXBUFE: Mask TXBUFE Interrupt**
- **RXBUFF: Mask RXBUFF Interrupt**

0 = The corresponding interrupt is disabled.

1 = The corresponding interrupt is enabled.

33.6.6 UART Status Register

Name: UART_SR

Address: 0x400E0614 (0), 0x400E0814 (1)

Access: Read-only

31	30	29	28	27	26	25	24
–	–	–	–	–	–	–	–
23	22	21	20	19	18	17	16
–	–	–	–	–	–	–	–
15	14	13	12	11	10	9	8
–	–	–	RXBUFF	TXBUFE	–	TXEMPTY	–
7	6	5	4	3	2	1	0
PARE	FRAME	OVRE	ENDTX	ENDRX	–	TXRDY	RXRDY

- **RXRDY: Receiver Ready**

0 = No character has been received since the last read of the UART_RHR or the receiver is disabled.

1 = At least one complete character has been received, transferred to UART_RHR and not yet read.

- **TXRDY: Transmitter Ready**

0 = A character has been written to UART_THR and not yet transferred to the Shift Register, or the transmitter is disabled.

1 = There is no character written to UART_THR not yet transferred to the Shift Register.

- **ENDRX: End of Receiver Transfer**

0 = The End of Transfer signal from the receiver Peripheral Data Controller channel is inactive.

1 = The End of Transfer signal from the receiver Peripheral Data Controller channel is active.

- **ENDTX: End of Transmitter Transfer**

0 = The End of Transfer signal from the transmitter Peripheral Data Controller channel is inactive.

1 = The End of Transfer signal from the transmitter Peripheral Data Controller channel is active.

- **OVRE: Overrun Error**

0 = No overrun error has occurred since the last RSTSTA.

1 = At least one overrun error has occurred since the last RSTSTA.

- **FRAME: Framing Error**

0 = No framing error has occurred since the last RSTSTA.

1 = At least one framing error has occurred since the last RSTSTA.

- **PARE: Parity Error**

0 = No parity error has occurred since the last RSTSTA.

1 = At least one parity error has occurred since the last RSTSTA.

- **TXEMPTY: Transmitter Empty**

0 = There are characters in UART_THR, or characters being processed by the transmitter, or the transmitter is disabled.

1 = There are no characters in UART_THR and there are no characters being processed by the transmitter.

- **TXBUFE: Transmission Buffer Empty**

0 = The buffer empty signal from the transmitter PDC channel is inactive.

1 = The buffer empty signal from the transmitter PDC channel is active.

- **RXBUFF: Receive Buffer Full**

0 = The buffer full signal from the receiver PDC channel is inactive.

1 = The buffer full signal from the receiver PDC channel is active.



33.6.7 UART Receiver Holding Register

Name: UART_RHR

Address: 0x400E0618 (0), 0x400E0818 (1)

Access: Read-only

31	30	29	28	27	26	25	24
–	–	–	–	–	–	–	–
23	22	21	20	19	18	17	16
–	–	–	–	–	–	–	–
15	14	13	12	11	10	9	8
–	–	–	–	–	–	–	–
7	6	5	4	3	2	1	0
RXCHR							

- **RXCHR: Received Character**
Last received character if RXRDY is set.



33.6.8 UART Transmit Holding Register

Name: UART_THR

Address: 0x400E061C (0), 0x400E081C (1)

Access: Write-only

31	30	29	28	27	26	25	24
–	–	–	–	–	–	–	–
23	22	21	20	19	18	17	16
–	–	–	–	–	–	–	–
15	14	13	12	11	10	9	8
–	–	–	–	–	–	–	–
7	6	5	4	3	2	1	0
TXCHR							

- **TXCHR: Character to be Transmitted**

Next character to be transmitted after the current character if TXRDY is not set.



33.6.9 UART Baud Rate Generator Register

Name: UART_BRGR

Address: 0x400E0620 (0), 0x400E0820 (1)

Access: Read-write

31	30	29	28	27	26	25	24
–	–	–	–	–	–	–	–
23	22	21	20	19	18	17	16
–	–	–	–	–	–	–	–
15	14	13	12	11	10	9	8
CD							
7	6	5	4	3	2	1	0
CD							

- **CD: Clock Divisor**

0 = Baud Rate Clock is disabled

1 to 65,535 = $MCK / (CD \times 16)$



34. Universal Synchronous Asynchronous Receiver Transmitter (USART)

34.1 Description

The Universal Synchronous Asynchronous Receiver Transceiver (USART) provides one full duplex universal synchronous asynchronous serial link. Data frame format is widely programmable (data length, parity, number of stop bits) to support a maximum of standards. The receiver implements parity error, framing error and overrun error detection. The receiver time-out enables handling variable-length frames and the transmitter timeguard facilitates communications with slow remote devices. Multidrop communications are also supported through address bit handling in reception and transmission.

The USART features three test modes: remote loopback, local loopback and automatic echo.

The USART supports specific operating modes providing interfaces on RS485 and SPI buses, with ISO7816 T = 0 or T = 1 smart card slots, infrared transceivers and connection to modem ports. The hardware handshaking feature enables an out-of-band flow control by automatic management of the pins RTS and CTS.

The USART supports the connection to the Peripheral DMA Controller, which enables data transfers to the transmitter and from the receiver. The PDC provides chained buffer management without any intervention of the processor.

34.2 Embedded Characteristics

- Programmable Baud Rate Generator
- 5- to 9-bit full-duplex synchronous or asynchronous serial communications
 - 1, 1.5 or 2 stop bits in Asynchronous Mode or 1 or 2 stop bits in Synchronous Mode
 - Parity generation and error detection
 - Framing error detection, overrun error detection
 - MSB- or LSB-first
 - Optional break generation and detection
 - By 8 or by-16 over-sampling receiver frequency
 - Hardware handshaking RTS-CTS
 - Receiver time-out and transmitter timeguard
 - Optional Multi-drop Mode with address generation and detection
 - Optional Manchester Encoding
 - Full modem line support on USART1 (DCD-DSR-DTR-RI)
- RS485 with driver control signal
- ISO7816, T = 0 or T = 1 Protocols for interfacing with smart cards
 - NACK handling, error counter with repetition and iteration limit
- SPI Mode
 - Master or Slave
 - Serial Clock programmable Phase and Polarity
 - SPI Serial Clock (SCK) Frequency up to MCK/4
- IrDA modulation and demodulation
 - Communication at up to 115.2 Kbps

- Test Modes
 - Remote Loopback, Local Loopback, Automatic Echo

34.3 Block Diagram

Figure 34-1. USART Block Diagram

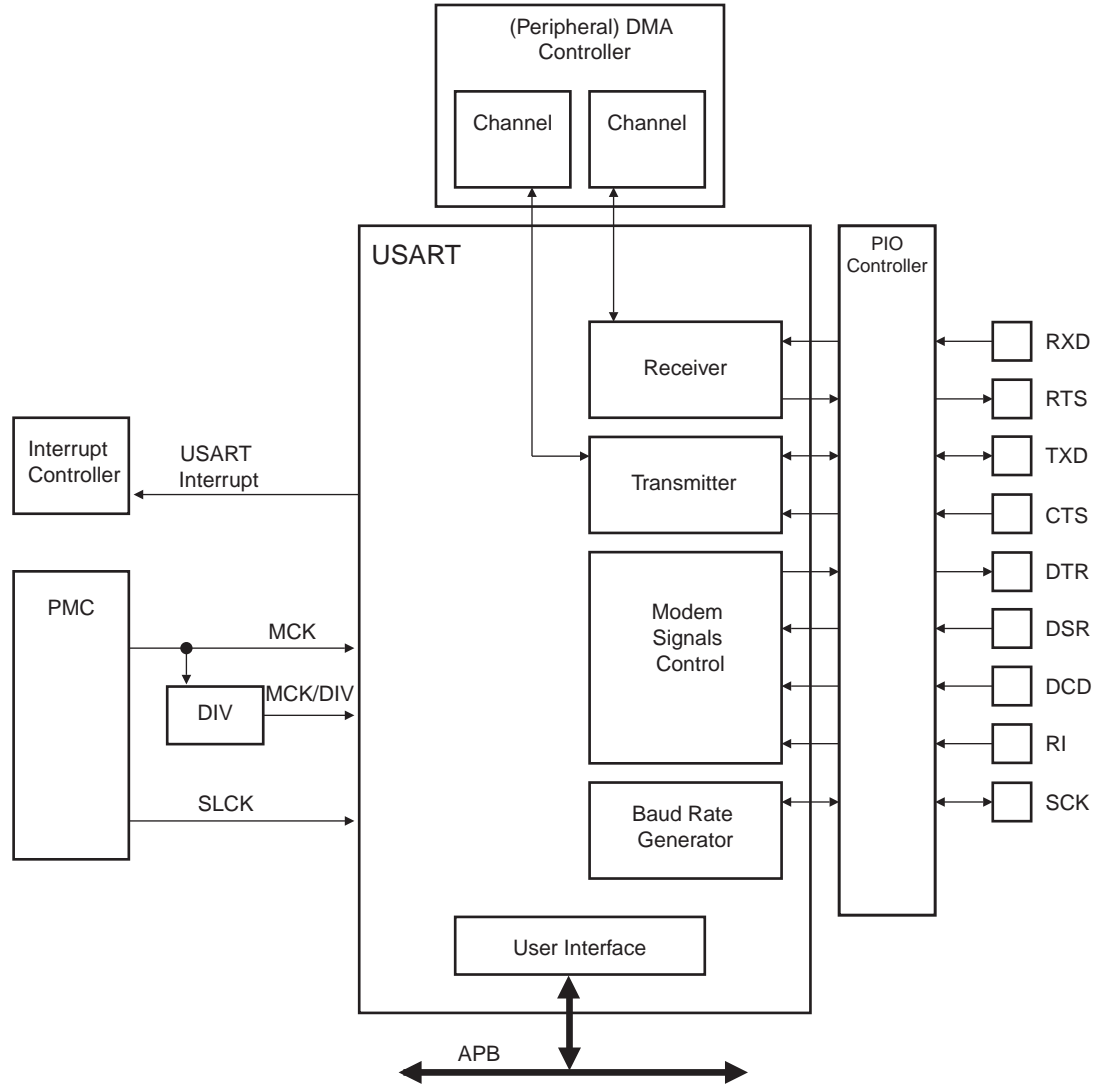
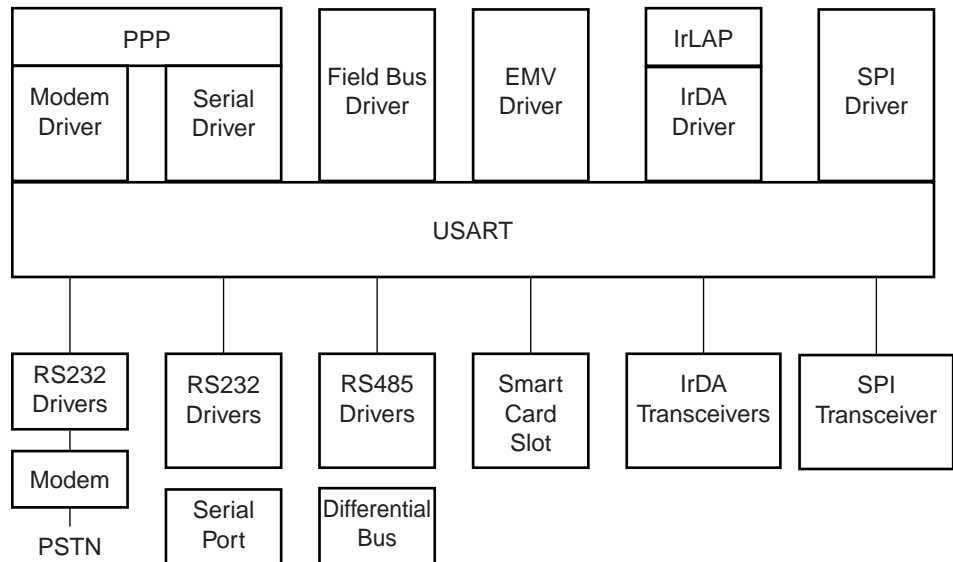

Table 34-1. SPI Operating Mode

PIN	USART	SPI Slave	SPI Master
RXD	RXD	MOSI	MISO
TXD	TXD	MISO	MOSI
RTS	RTS	–	CS
CTS	CTS	CS	–

34.4 Application Block Diagram

Figure 34-2. Application Block Diagram



34.5 I/O Lines Description

Table 34-2. I/O Line Description

Name	Description	Type	Active Level
SCK	Serial Clock	I/O	
TXD	Transmit Serial Data or Master Out Slave In (MOSI) in SPI Master Mode or Master In Slave Out (MISO) in SPI Slave Mode	I/O	
RXD	Receive Serial Data or Master In Slave Out (MISO) in SPI Master Mode or Master Out Slave In (MOSI) in SPI Slave Mode	Input	
RI	Ring Indicator	Input	Low
DSR	Data Set Ready	Input	Low
DCD	Data Carrier Detect	Input	Low
DTR	Data Terminal Ready	Output	Low
CTS	Clear to Send or Slave Select (NSS) in SPI Slave Mode	Input	Low
RTS	Request to Send or Slave Select (NSS) in SPI Master Mode	Output	Low

34.6 Product Dependencies

34.6.1 I/O Lines

The pins used for interfacing the USART may be multiplexed with the PIO lines. The programmer must first program the PIO controller to assign the desired USART pins to their peripheral function. If I/O lines of the USART are not used by the application, they can be used for other purposes by the PIO Controller.

To prevent the TXD line from falling when the USART is disabled, the use of an internal pull up is mandatory. If the hardware handshaking feature or Modem mode is used, the internal pull up on TXD must also be enabled. All the pins of the modems may or may not be implemented on the USART. Only USART1 fully equipped with all the modem signals. On USARTs not equipped with the corresponding pin, the associated control bits and statuses have no effect on the behavior of the USART.

Table 34-3. I/O Lines

Instance	Signal	I/O Line	Peripheral
USART0	CTS0	PA8	A
USART0	RTS0	PA7	A
USART0	RXD0	PA5	A
USART0	SCK0	PA2	B
USART0	TXD0	PA6	A
USART1	CTS1	PA25	A
USART1	DCD1	PA26	A
USART1	DSR1	PA28	A
USART1	DTR1	PA27	A
USART1	RI1	PA29	A
USART1	RTS1	PA24	A
USART1	RXD1	PA21	A
USART1	SCK1	PA23	A
USART1	TXD1	PA22	A

34.6.2 Power Management

The USART is not continuously clocked. The programmer must first enable the USART Clock in the Power Management Controller (PMC) before using the USART. However, if the application does not require USART operations, the USART clock can be stopped when not needed and be restarted later. In this case, the USART will resume its operations where it left off.

Configuring the USART does not require the USART clock to be enabled.

34.6.3 Interrupt

The USART interrupt line is connected on one of the internal sources of the Interrupt Controller. Using the USART interrupt requires the Interrupt Controller to be programmed first. Note that it is not recommended to use the USART interrupt line in edge sensitive mode.

Table 34-4. Peripheral IDs

Instance	ID
USART0	14
USART1	15

34.7 Functional Description

The USART is capable of managing several types of serial synchronous or asynchronous communications.

It supports the following communication modes:

- 5- to 9-bit full-duplex asynchronous serial communication
 - MSB- or LSB-first
 - 1, 1.5 or 2 stop bits
 - Parity even, odd, marked, space or none
 - By 8 or by 16 over-sampling receiver frequency
 - Optional hardware handshaking
 - Optional modem signals management
 - Optional break management
 - Optional multidrop serial communication
- High-speed 5- to 9-bit full-duplex synchronous serial communication
 - MSB- or LSB-first
 - 1 or 2 stop bits
 - Parity even, odd, marked, space or none
 - By 8 or by 16 over-sampling frequency
 - Optional hardware handshaking
 - Optional modem signals management
 - Optional break management
 - Optional multidrop serial communication
- RS485 with driver control signal
- ISO7816, T0 or T1 protocols for interfacing with smart cards
 - NACK handling, error counter with repetition and iteration limit, inverted data.
- InfraRed IrDA Modulation and Demodulation
- SPI Mode
 - Master or Slave
 - Serial Clock Programmable Phase and Polarity
 - SPI Serial Clock (SCK) Frequency up to Internal Clock Frequency MCK/6
- Test modes
 - Remote loopback, local loopback, automatic echo

34.7.1 Baud Rate Generator

The Baud Rate Generator provides the bit period clock named the Baud Rate Clock to both the receiver and the transmitter.

The Baud Rate Generator clock source can be selected by setting the USCLKS field in the Mode Register (US_MR) between:

- The Master Clock MCK
- A division of the Master Clock, the divider being product dependent, but generally set to 8
- The external clock, available on the SCK pin

The Baud Rate Generator is based upon a 16-bit divider, which is programmed with the CD field of the Baud Rate Generator Register (US_BRGR). If CD is programmed to 0, the Baud Rate Generator does not generate any clock. If CD is programmed to 1, the divider is bypassed and becomes inactive.

If the external SCK clock is selected, the duration of the low and high levels of the signal provided on the SCK pin must be longer than a Master Clock (MCK) period. The frequency of the signal provided on SCK must be at least 3 times lower than MCK in USART mode, or 6 in SPI mode.

Figure 34-3. Baud Rate Generator

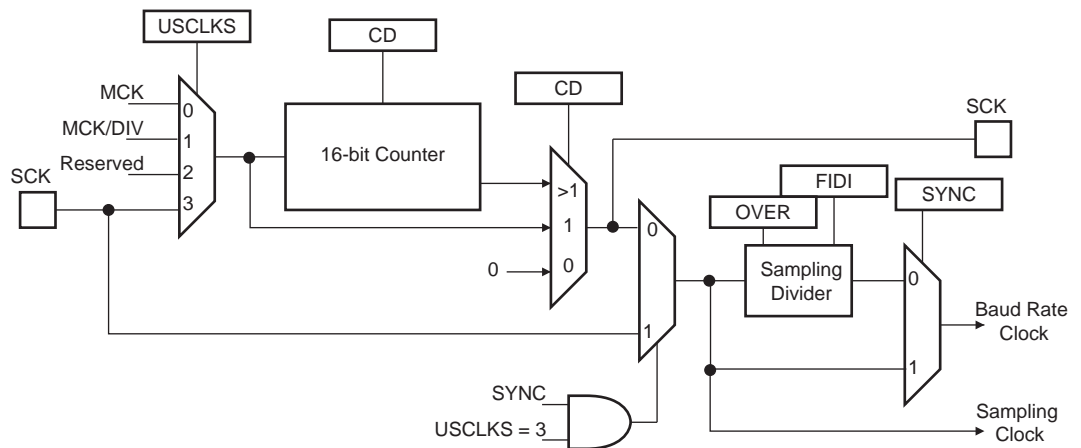

34.7.1.1 Baud Rate in Asynchronous Mode

If the USART is programmed to operate in asynchronous mode, the selected clock is first divided by CD, which is field programmed in the Baud Rate Generator Register (US_BRGR). The resulting clock is provided to the receiver as a sampling clock and then divided by 16 or 8, depending on the programming of the OVER bit in US_MR.

If OVER is set to 1, the receiver sampling is 8 times higher than the baud rate clock. If OVER is cleared, the sampling is performed at 16 times the baud rate clock.

The following formula performs the calculation of the Baud Rate.

$$\text{Baudrate} = \frac{\text{SelectedClock}}{(8(2 - \text{Over})CD)}$$

This gives a maximum baud rate of MCK divided by 8, assuming that MCK is the highest possible clock and that OVER is programmed to 1.

Baud Rate Calculation Example

Table 34-5 shows calculations of CD to obtain a baud rate at 38400 bauds for different source clock frequencies. This table also shows the actual resulting baud rate and the error.

Table 34-5. Baud Rate Example (OVER = 0)

Source Clock	Expected Baud Rate	Calculation Result	CD	Actual Baud Rate	Error
MHz	Bit/s			Bit/s	
3 686 400	38 400	6.00	6	38 400.00	0.00%
4 915 200	38 400	8.00	8	38 400.00	0.00%
5 000 000	38 400	8.14	8	39 062.50	1.70%
7 372 800	38 400	12.00	12	38 400.00	0.00%
8 000 000	38 400	13.02	13	38 461.54	0.16%
12 000 000	38 400	19.53	20	37 500.00	2.40%
12 288 000	38 400	20.00	20	38 400.00	0.00%
14 318 180	38 400	23.30	23	38 908.10	1.31%
14 745 600	38 400	24.00	24	38 400.00	0.00%
18 432 000	38 400	30.00	30	38 400.00	0.00%
24 000 000	38 400	39.06	39	38 461.54	0.16%
24 576 000	38 400	40.00	40	38 400.00	0.00%
25 000 000	38 400	40.69	40	38 109.76	0.76%
32 000 000	38 400	52.08	52	38 461.54	0.16%
32 768 000	38 400	53.33	53	38 641.51	0.63%
33 000 000	38 400	53.71	54	38 194.44	0.54%
40 000 000	38 400	65.10	65	38 461.54	0.16%
50 000 000	38 400	81.38	81	38 580.25	0.47%

The baud rate is calculated with the following formula:

$$\text{BaudRate} = \text{MCK} / \text{CD} \times 16$$

The baud rate error is calculated with the following formula. It is not recommended to work with an error higher than 5%.

$$\text{Error} = 1 - \left(\frac{\text{ExpectedBaudRate}}{\text{ActualBaudRate}} \right)$$

34.7.1.2 Fractional Baud Rate in Asynchronous Mode

The Baud Rate generator previously defined is subject to the following limitation: the output frequency changes by only integer multiples of the reference frequency. An approach to this problem is to integrate a fractional N clock generator that has a high resolution. The generator architecture is modified to obtain Baud Rate changes by a fraction of the reference source clock.

This fractional part is programmed with the FP field in the Baud Rate Generator Register (US_BRGR). If FP is not 0, the fractional part is activated. The resolution is one eighth of the clock divider. This feature is only available when using USART normal mode. The fractional Baud Rate is calculated using the following formula:

$$\text{Baudrate} = \frac{\text{SelectedClock}}{\left(8(2 - \text{Over})\left(\text{CD} + \frac{\text{FP}}{8}\right)\right)}$$

The modified architecture is presented below:

Figure 34-4. Fractional Baud Rate Generator

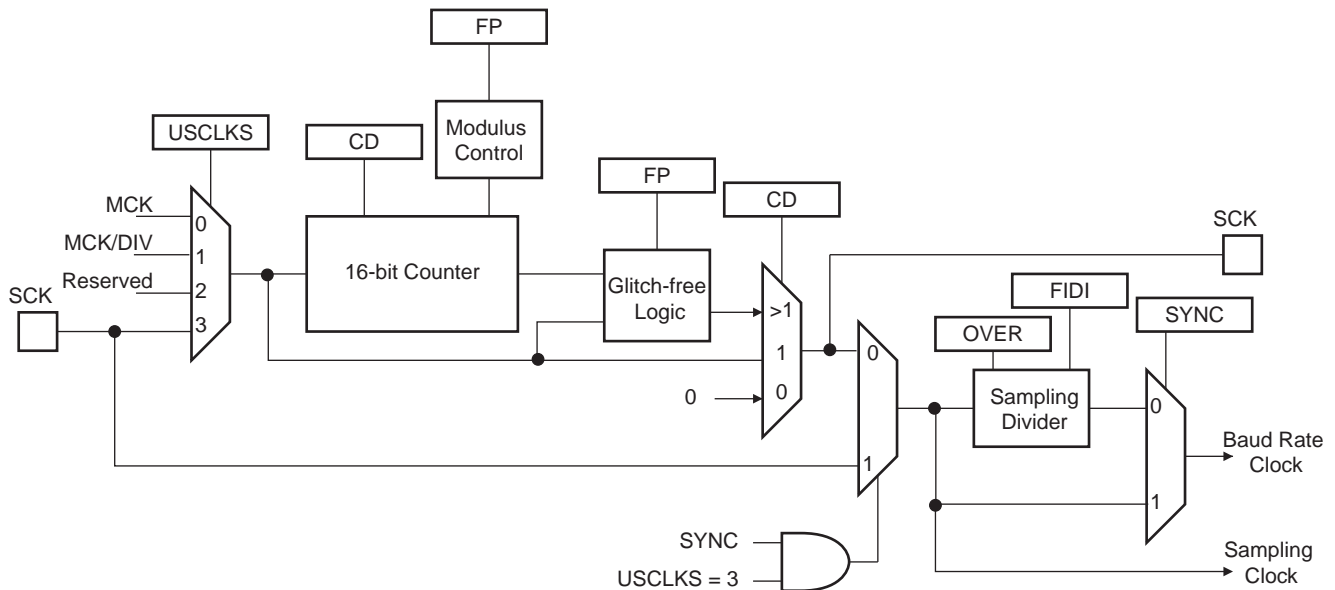

34.7.1.3 Baud Rate in Synchronous Mode or SPI Mode

If the USART is programmed to operate in synchronous mode, the selected clock is simply divided by the field CD in US_BRGR.

$$\text{BaudRate} = \frac{\text{SelectedClock}}{\text{CD}}$$

In synchronous mode, if the external clock is selected (USCLKS = 3), the clock is provided directly by the signal on the USART SCK pin. No division is active. The value written in US_BRGR has no effect. The external clock frequency must be at least 3 times lower than the system clock. In synchronous mode master (USCLKS = 0 or 1, CLK0 set to 1), the receive part limits the SCK maximum frequency to MCK/3 in USART mode, or MCK/6 in SPI mode.

When either the external clock SCK or the internal clock divided (MCK/DIV) is selected, the value programmed in CD must be even if the user has to ensure a 50:50 mark/space ratio on the SCK pin. If the internal clock MCK is selected, the Baud Rate Generator ensures a 50:50 duty cycle on the SCK pin, even if the value programmed in CD is odd.

34.7.1.4 Baud Rate in ISO 7816 Mode

The ISO7816 specification defines the bit rate with the following formula:

$$B = \frac{D_i}{F_i} \times f$$

where:

- B is the bit rate
- Di is the bit-rate adjustment factor
- Fi is the clock frequency division factor
- f is the ISO7816 clock frequency (Hz)

Di is a binary value encoded on a 4-bit field, named DI, as represented in [Table 34-6](#).

Table 34-6. Binary and Decimal Values for Di

DI field	0001	0010	0011	0100	0101	0110	1000	1001
Di (decimal)	1	2	4	8	16	32	12	20

Fi is a binary value encoded on a 4-bit field, named FI, as represented in [Table 34-7](#).

Table 34-7. Binary and Decimal Values for Fi

FI field	0000	0001	0010	0011	0100	0101	0110	1001	1010	1011	1100	1101
Fi (decimal)	372	372	558	744	1116	1488	1860	512	768	1024	1536	2048

[Table 34-8](#) shows the resulting Fi/Di Ratio, which is the ratio between the ISO7816 clock and the baud rate clock.

Table 34-8. Possible Values for the Fi/Di Ratio

Fi/Di	372	558	774	1116	1488	1806	512	768	1024	1536	2048
1	372	558	744	1116	1488	1860	512	768	1024	1536	2048
2	186	279	372	558	744	930	256	384	512	768	1024
4	93	139.5	186	279	372	465	128	192	256	384	512
8	46.5	69.75	93	139.5	186	232.5	64	96	128	192	256
16	23.25	34.87	46.5	69.75	93	116.2	32	48	64	96	128
32	11.62	17.43	23.25	34.87	46.5	58.13	16	24	32	48	64
12	31	46.5	62	93	124	155	42.66	64	85.33	128	170.6
20	18.6	27.9	37.2	55.8	74.4	93	25.6	38.4	51.2	76.8	102.4

If the USART is configured in ISO7816 Mode, the clock selected by the USCLKS field in the Mode Register (US_MR) is first divided by the value programmed in the field CD in the Baud Rate Generator Register (US_BRGR). The resulting clock can be provided to the SCK pin to feed the smart card clock inputs. This means that the CLKO bit can be set in US_MR.

This clock is then divided by the value programmed in the FI_DI_RATIO field in the FI_DI_Ratio register (US_FIDI). This is performed by the Sampling Divider, which performs a division by up to 2047 in ISO7816 Mode. The non-integer values of the Fi/Di Ratio are not supported and the user must program the FI_DI_RATIO field to a value as close as possible to the expected value.

The FI_DI_RATIO field resets to the value 0x174 (372 in decimal) and is the most common divider between the ISO7816 clock and the bit rate (Fi = 372, Di = 1).

Figure 34-5 shows the relation between the Elementary Time Unit, corresponding to a bit time, and the ISO 7816 clock.

Figure 34-5. Elementary Time Unit (ETU)

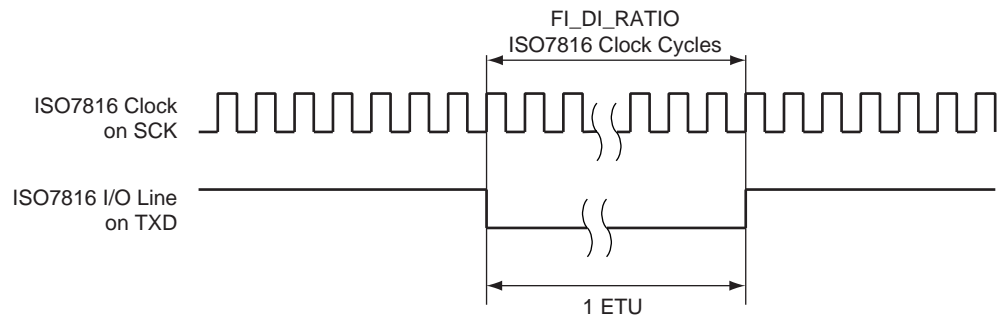

34.7.2 Receiver and Transmitter Control

After reset, the receiver is disabled. The user must enable the receiver by setting the RXEN bit in the Control Register (US_CR). However, the receiver registers can be programmed before the receiver clock is enabled.

After reset, the transmitter is disabled. The user must enable it by setting the TXEN bit in the Control Register (US_CR). However, the transmitter registers can be programmed before being enabled.

The Receiver and the Transmitter can be enabled together or independently.

At any time, the software can perform a reset on the receiver or the transmitter of the USART by setting the corresponding bit, RSTRX and RSTTX respectively, in the Control Register (US_CR). The software resets clear the status flag and reset internal state machines but the user interface configuration registers hold the value configured prior to software reset. Regardless of what the receiver or the transmitter is performing, the communication is immediately stopped.

The user can also independently disable the receiver or the transmitter by setting RXDIS and TXDIS respectively in US_CR. If the receiver is disabled during a character reception, the USART waits until the end of reception of the current character, then the reception is stopped. If the transmitter is disabled while it is operating, the USART waits the end of transmission of both the current character and character being stored in the Transmit Holding Register (US_THR). If a timeguard is programmed, it is handled normally.

34.7.3 Synchronous and Asynchronous Modes

34.7.3.1 Transmitter Operations

The transmitter performs the same in both synchronous and asynchronous operating modes (SYNC = 0 or SYNC = 1). One start bit, up to 9 data bits, one optional parity bit and up to two stop bits are successively shifted out on the TXD pin at each falling edge of the programmed serial clock.

The number of data bits is selected by the CHRL field and the MODE 9 bit in the Mode Register (US_MR). Nine bits are selected by setting the MODE 9 bit regardless of the CHRL field. The parity bit is set according to the PAR field in US_MR. The even, odd, space, marked or none parity bit can be configured. The MSBF field in US_MR configures which data bit is sent first. If written to 1, the most significant bit is sent first. If written to 0, the less significant bit is sent first.

The number of stop bits is selected by the NBSTOP field in US_MR. The 1.5 stop bit is supported in asynchronous mode only.

Figure 34-6. Character Transmit

Example: 8-bit, Parity Enabled One Stop

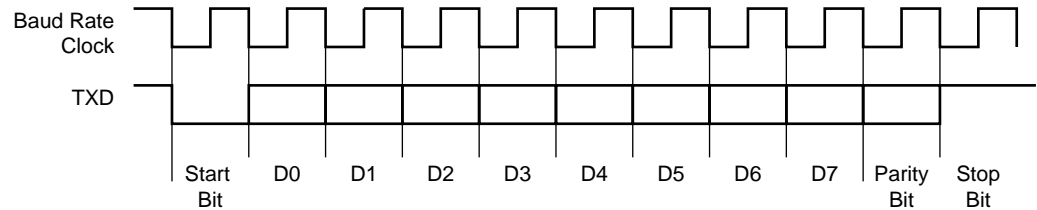

The characters are sent by writing in the Transmit Holding Register (US_THR). The transmitter reports two status bits in the Channel Status Register (US_CSR): TXRDY (Transmitter Ready), which indicates that US_THR is empty and TXEMPTY, which indicates that all the characters written in US_THR have been processed. When the current character processing is completed, the last character written in US_THR is transferred into the Shift Register of the transmitter and US_THR becomes empty, thus TXRDY rises.

Both TXRDY and TXEMPTY bits are low when the transmitter is disabled. Writing a character in US_THR while TXRDY is low has no effect and the written character is lost.

Figure 34-7. Transmitter Status

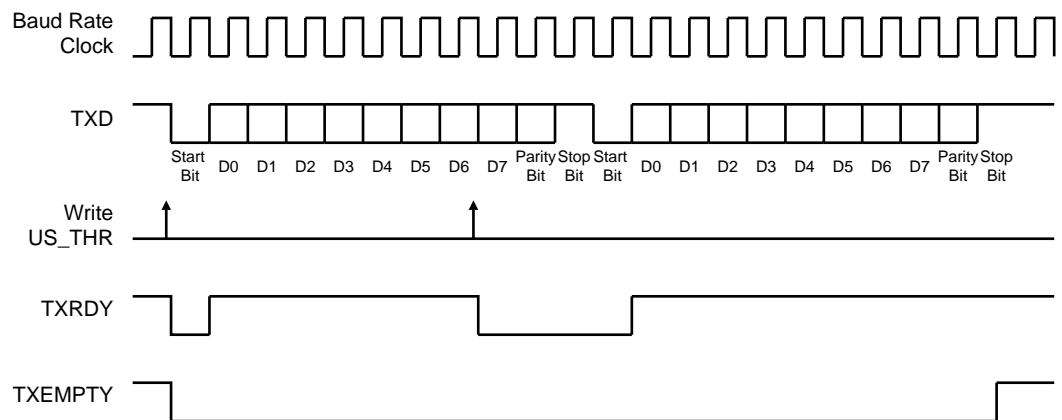

34.7.3.2 Manchester Encoder

When the Manchester encoder is in use, characters transmitted through the USART are encoded based on biphase Manchester II format. To enable this mode, set the MAN field in the US_MR register to 1. Depending on polarity configuration, a logic level (zero or one), is transmitted as a coded signal one-to-zero or zero-to-one. Thus, a transition always occurs at the midpoint of each bit time. It consumes more bandwidth than the original NRZ signal (2x) but the receiver has more error control since the expected input must show a change at the center of a bit cell. An example of Manchester encoded sequence is: the byte 0xB1 or 10110001 encodes to 10 01 10 10 01 01 01 10, assuming the default polarity of the encoder. [Figure 34-8](#) illustrates this coding scheme.

Figure 34-8. NRZ to Manchester Encoding

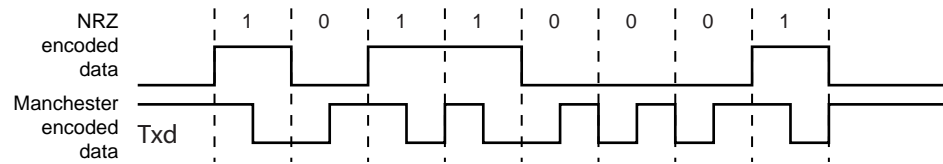

The Manchester encoded character can also be encapsulated by adding both a configurable preamble and a start frame delimiter pattern. Depending on the configuration, the preamble is a training sequence, composed of a pre-defined pattern with a programmable length from 1 to 15 bit times. If the preamble length is set to 0, the preamble waveform is not generated prior to any character. The preamble pattern is chosen among the following sequences: ALL_ONE, ALL_ZERO, ONE_ZERO or ZERO_ONE, writing the field TX_PP in the US_MAN register, the field TX_PL is used to configure the preamble length. Figure 34-9 illustrates and defines the valid patterns. To improve flexibility, the encoding scheme can be configured using the TX_MPOL field in the US_MAN register. If the TX_MPOL field is set to zero (default), a logic zero is encoded with a zero-to-one transition and a logic one is encoded with a one-to-zero transition. If the TX_MPOL field is set to one, a logic one is encoded with a one-to-zero transition and a logic zero is encoded with a zero-to-one transition.

Figure 34-9. Preamble Patterns, Default Polarity Assumed

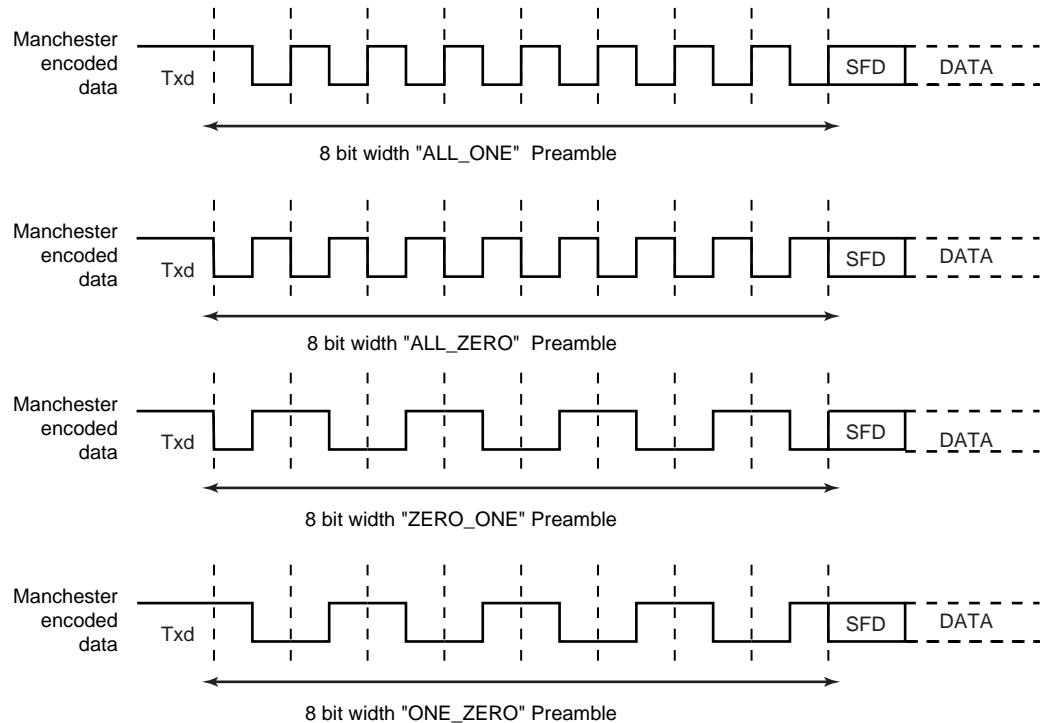

A start frame delimiter is to be configured using the ONEBIT field in the US_MR register. It consists of a user-defined pattern that indicates the beginning of a valid data. Figure 34-10 illustrates these patterns. If the start frame delimiter, also known as start bit, is one bit, (ONEBIT to 1), a logic zero is Manchester encoded and indicates that a new character is being sent serially on the line. If the start frame delimiter is a synchronization pattern also referred to as sync (ONEBIT to 0), a sequence of 3 bit times is sent serially on the line to indicate the start of a new

character. The sync waveform is in itself an invalid Manchester waveform as the transition occurs at the middle of the second bit time. Two distinct sync patterns are used: the command sync and the data sync. The command sync has a logic one level for one and a half bit times, then a transition to logic zero for the second one and a half bit times. If the MODSYNC field in the US_MR register is set to 1, the next character is a command. If it is set to 0, the next character is a data. When direct memory access is used, the MODSYNC field can be immediately updated with a modified character located in memory. To enable this mode, VAR_SYNC field in US_MR register must be set to 1. In this case, the MODSYNC field in US_MR is bypassed and the sync configuration is held in the TXSYNH in the US_THR register. The USART character format is modified and includes sync information.

Figure 34-10. Start Frame Delimiter

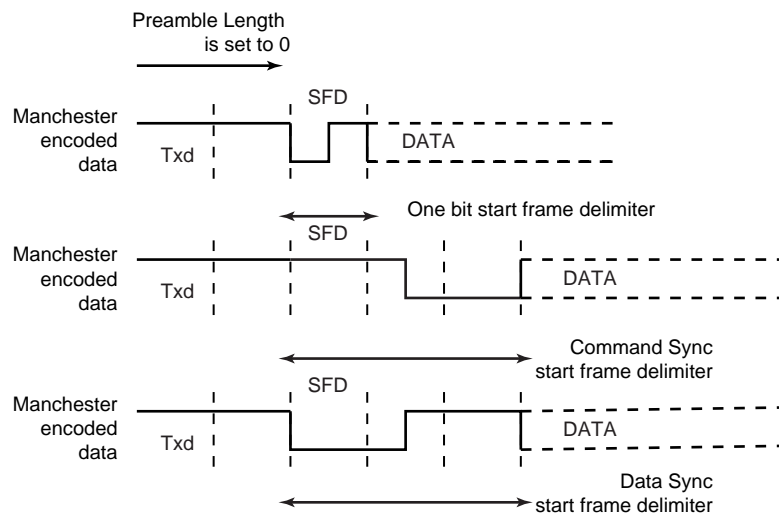

Drift Compensation

Drift compensation is available only in 16X oversampling mode. An hardware recovery system allows a larger clock drift. To enable the hardware system, the bit in the USART_MAN register must be set. If the RXD edge is one 16X clock cycle from the expected edge, this is considered as normal jitter and no corrective actions is taken. If the RXD event is between 4 and 2 clock cycles before the expected edge, then the current period is shortened by one clock cycle. If the RXD event is between 2 and 3 clock cycles after the expected edge, then the current period is lengthened by one clock cycle. These intervals are considered to be drift and so corrective actions are automatically taken.

Figure 34-11. Bit Resynchronization

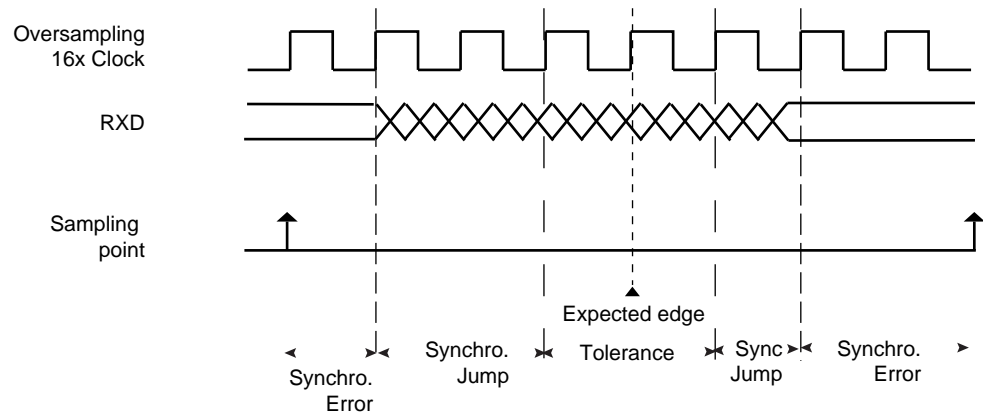

34.7.3.3 Asynchronous Receiver

If the USART is programmed in asynchronous operating mode ($SYNC = 0$), the receiver oversamples the RXD input line. The oversampling is either 16 or 8 times the Baud Rate clock, depending on the OVER bit in the Mode Register (US_MR).

The receiver samples the RXD line. If the line is sampled during one half of a bit time to 0, a start bit is detected and data, parity and stop bits are successively sampled on the bit rate clock.

If the oversampling is 16, (OVER to 0), a start is detected at the eighth sample to 0. Then, data bits, parity bit and stop bit are sampled on each 16 sampling clock cycle. If the oversampling is 8 (OVER to 1), a start bit is detected at the fourth sample to 0. Then, data bits, parity bit and stop bit are sampled on each 8 sampling clock cycle.

The number of data bits, first bit sent and parity mode are selected by the same fields and bits as the transmitter, i.e. respectively CHRL, MODE9, MSBF and PAR. For the synchronization mechanism only, the number of stop bits has no effect on the receiver as it considers only one stop bit, regardless of the field NBSTOP, so that resynchronization between the receiver and the transmitter can occur. Moreover, as soon as the stop bit is sampled, the receiver starts looking for a new start bit so that resynchronization can also be accomplished when the transmitter is operating with one stop bit.

Figure 34-12 and Figure 34-13 illustrate start detection and character reception when USART operates in asynchronous mode.

Figure 34-12. Asynchronous Start Detection

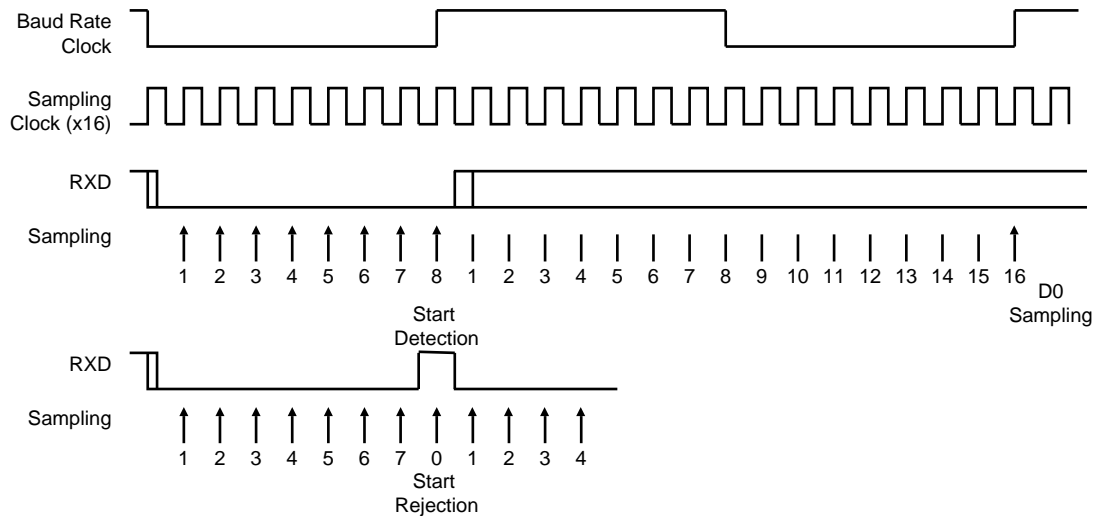
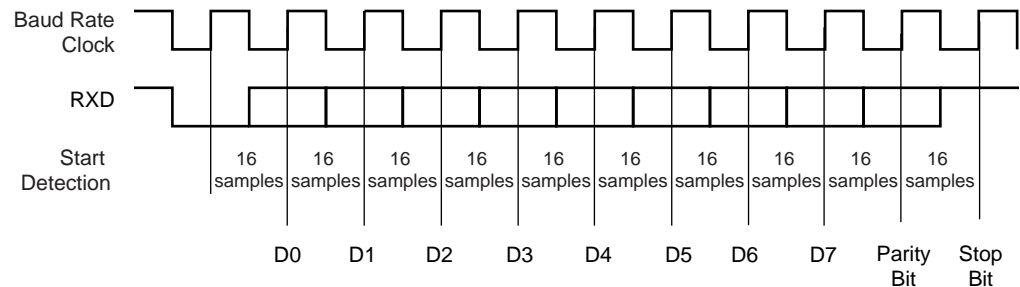

Figure 34-13. Asynchronous Character Reception

Example: 8-bit, Parity Enabled



34.7.3.4 Manchester Decoder

When the MAN field in US_MR register is set to 1, the Manchester decoder is enabled. The decoder performs both preamble and start frame delimiter detection. One input line is dedicated to Manchester encoded input data.

An optional preamble sequence can be defined, its length is user-defined and totally independent of the emitter side. Use RX_PL in US_MAN register to configure the length of the preamble sequence. If the length is set to 0, no preamble is detected and the function is disabled. In addition, the polarity of the input stream is programmable with RX_MPOL field in US_MAN register. Depending on the desired application the preamble pattern matching is to be defined via the RX_PP field in US_MAN. See [Figure 34-9](#) for available preamble patterns.

Unlike preamble, the start frame delimiter is shared between Manchester Encoder and Decoder. So, if ONEBIT field is set to 1, only a zero encoded Manchester can be detected as a valid start frame delimiter. If ONEBIT is set to 0, only a sync pattern is detected as a valid start frame delimiter. Decoder operates by detecting transition on incoming stream. If RXD is sampled during one quarter of a bit time to zero, a start bit is detected. See [Figure 34-14](#). The sample pulse rejection mechanism applies.

In order to increase the compatibility the RXIDLV bit in the US_MAN register allows to inform the USART block of the Rx line idle state value (Rx line undriven), it can be either level one (pull-up) or level zero (pull-down). By default this bit is set to one (Rx line is at level 1 if undriven).

Figure 34-14. Asynchronous Start Bit Detection

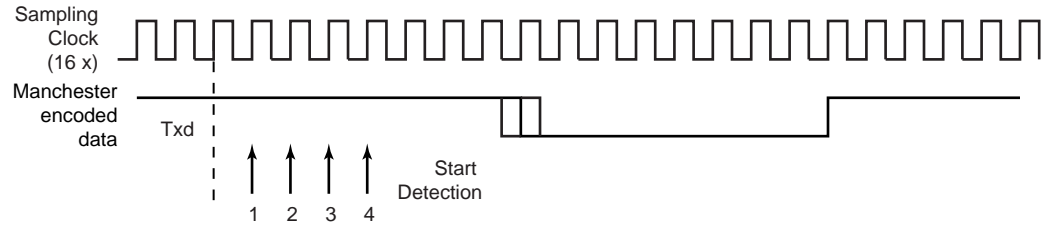

The receiver is activated and starts Preamble and Frame Delimiter detection, sampling the data at one quarter and then three quarters. If a valid preamble pattern or start frame delimiter is detected, the receiver continues decoding with the same synchronization. If the stream does not match a valid pattern or a valid start frame delimiter, the receiver re-synchronizes on the next valid edge. The minimum time threshold to estimate the bit value is three quarters of a bit time.

If a valid preamble (if used) followed with a valid start frame delimiter is detected, the incoming stream is decoded into NRZ data and passed to USART for processing. Figure 34-15 illustrates Manchester pattern mismatch. When incoming data stream is passed to the USART, the receiver is also able to detect Manchester code violation. A code violation is a lack of transition in the middle of a bit cell. In this case, MANE flag in US_CSR register is raised. It is cleared by writing the Control Register (US_CR) with the RSTSTA bit to 1. See Figure 34-16 for an example of Manchester error detection during data phase.

Figure 34-15. Preamble Pattern Mismatch

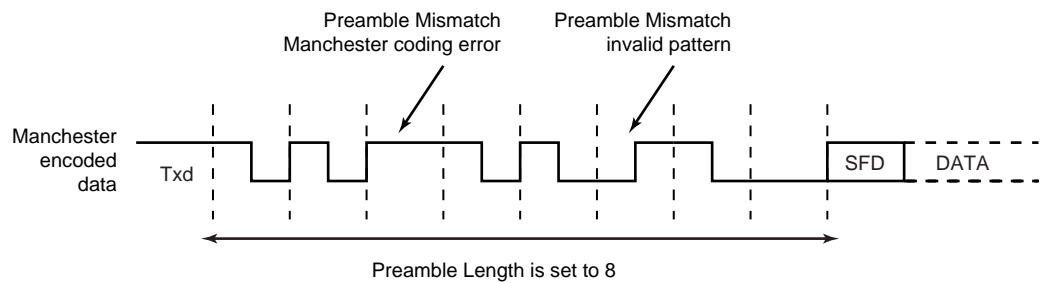
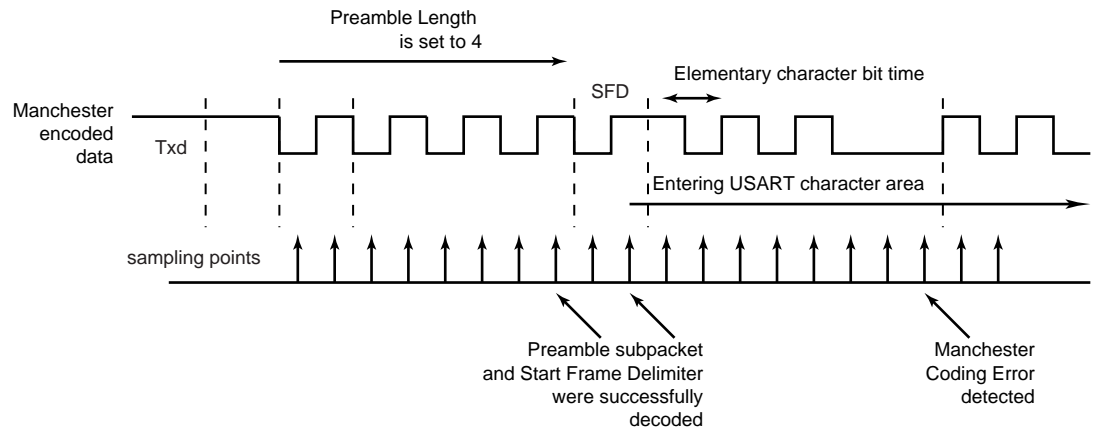

Figure 34-16. Manchester Error Flag



When the start frame delimiter is a sync pattern (ONEBIT field to 0), both command and data delimiter are supported. If a valid sync is detected, the received character is written as RXCHR field in the US_RHR register and the RXSYNH is updated. RXCHR is set to 1 when the received character is a command, and it is set to 0 if the received character is a data. This mechanism alleviates and simplifies the direct memory access as the character contains its own sync field in the same register.

As the decoder is setup to be used in unipolar mode, the first bit of the frame has to be a zero-to-one transition.

34.7.3.5 Radio Interface: Manchester Encoded USART Application

This section describes low data rate RF transmission systems and their integration with a Manchester encoded USART. These systems are based on transmitter and receiver ICs that support ASK and FSK modulation schemes.

The goal is to perform full duplex radio transmission of characters using two different frequency carriers. See the configuration in [Figure 34-17](#).

Figure 34-17. Manchester Encoded Characters RF Transmission

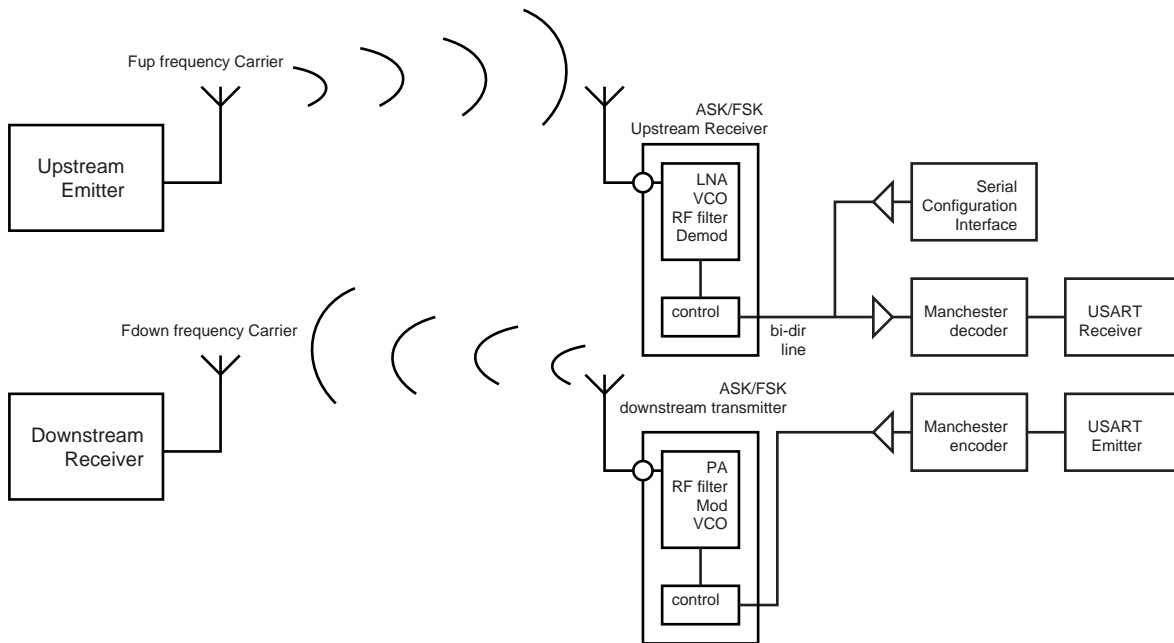

The USART module is configured as a Manchester encoder/decoder. Looking at the downstream communication channel, Manchester encoded characters are serially sent to the RF emitter. This may also include a user defined preamble and a start frame delimiter. Mostly, preamble is used in the RF receiver to distinguish between a valid data from a transmitter and signals due to noise. The Manchester stream is then modulated. See [Figure 34-18](#) for an example of ASK modulation scheme. When a logic one is sent to the ASK modulator, the power amplifier, referred to as PA, is enabled and transmits an RF signal at downstream frequency. When a logic zero is transmitted, the RF signal is turned off. If the FSK modulator is activated, two different frequencies are used to transmit data. When a logic 1 is sent, the modulator outputs an RF signal at frequency F_0 and switches to F_1 if the data sent is a 0. See [Figure 34-19](#).

From the receiver side, another carrier frequency is used. The RF receiver performs a bit check operation examining demodulated data stream. If a valid pattern is detected, the receiver switches to receiving mode. The demodulated stream is sent to the Manchester decoder. Because of bit checking inside RF IC, the data transferred to the microcontroller is reduced by a user-defined number of bits. The Manchester preamble length is to be defined in accordance with the RF IC configuration.

Figure 34-18. ASK Modulator Output

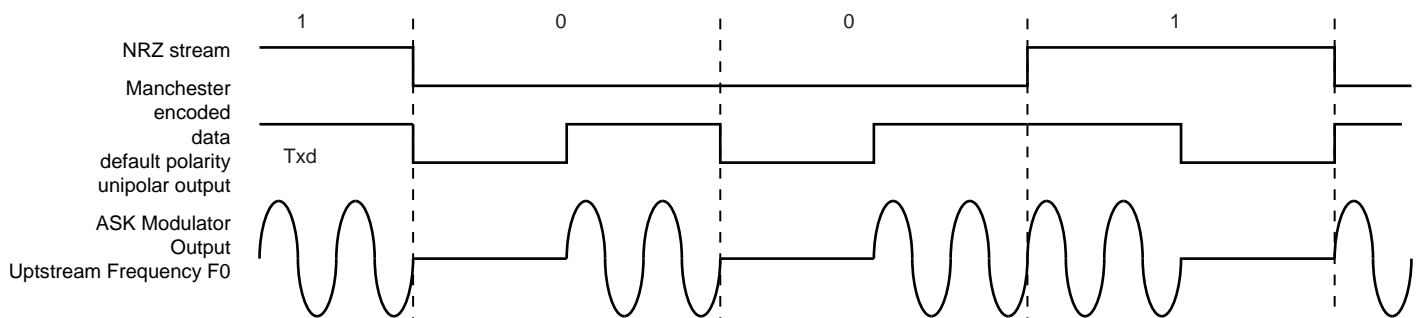
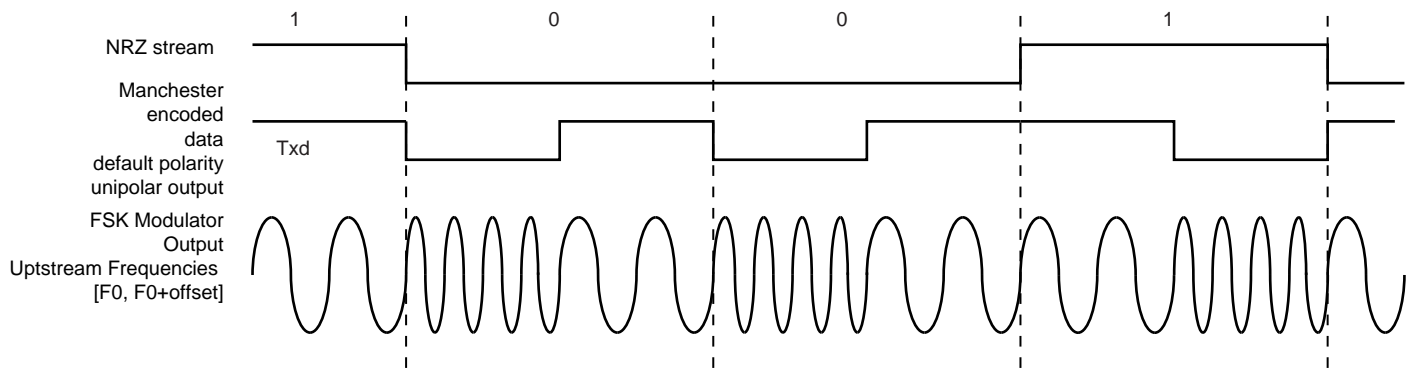

Figure 34-19. FSK Modulator Output



34.7.3.6 Synchronous Receiver

In synchronous mode (SYNC = 1), the receiver samples the RXD signal on each rising edge of the Baud Rate Clock. If a low level is detected, it is considered as a start. All data bits, the parity bit and the stop bits are sampled and the receiver waits for the next start bit. Synchronous mode operations provide a high speed transfer capability.

Configuration fields and bits are the same as in asynchronous mode.

Figure 34-20 illustrates a character reception in synchronous mode.

Figure 34-20. Synchronous Mode Character Reception

Example: 8-bit, Parity Enabled 1 Stop

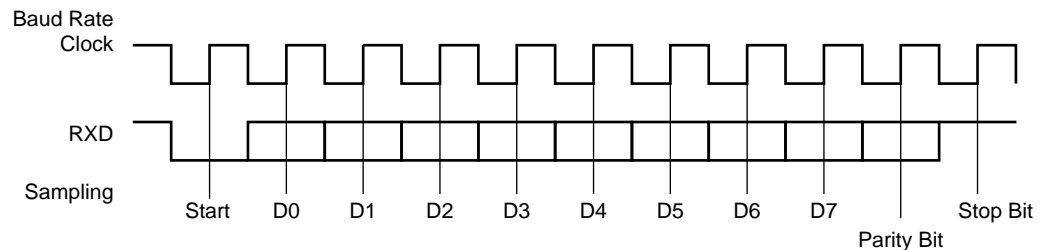

34.7.3.7 Receiver Operations

When a character reception is completed, it is transferred to the Receive Holding Register (US_RHR) and the RXRDY bit in the Status Register (US_CSR) rises. If a character is completed while the RXRDY is set, the OVRE (Overrun Error) bit is set. The last character is transferred into US_RHR and overwrites the previous one. The OVRE bit is cleared by writing the Control Register (US_CR) with the RSTSTA (Reset Status) bit to 1.

Figure 34-21. Receiver Status

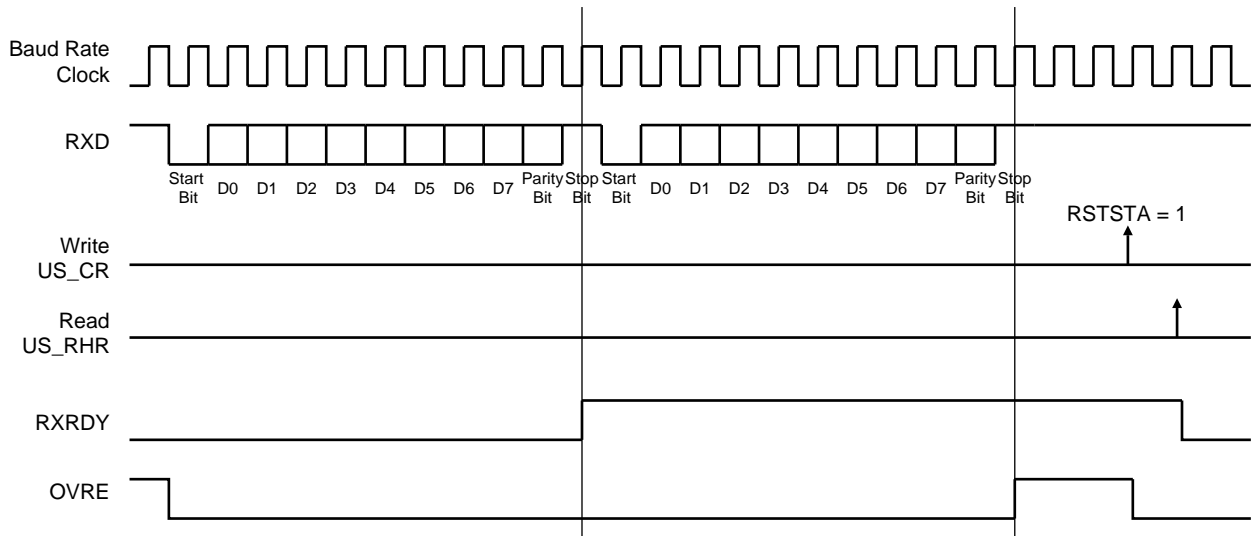

34.7.3.8 Parity

The USART supports five parity modes selected by programming the PAR field in the Mode Register (US_MR). The PAR field also enables the Multidrop mode, see [“Multidrop Mode” on page 749](#). Even and odd parity bit generation and error detection are supported.

If even parity is selected, the parity generator of the transmitter drives the parity bit to 0 if a number of 1s in the character data bit is even, and to 1 if the number of 1s is odd. Accordingly, the receiver parity checker counts the number of received 1s and reports a parity error if the sampled parity bit does not correspond. If odd parity is selected, the parity generator of the transmitter drives the parity bit to 1 if a number of 1s in the character data bit is even, and to 0 if the number of 1s is odd. Accordingly, the receiver parity checker counts the number of received 1s and reports a parity error if the sampled parity bit does not correspond. If the mark parity is used, the parity generator of the transmitter drives the parity bit to 1 for all characters. The receiver parity checker reports an error if the parity bit is sampled to 0. If the space parity is used, the parity generator of the transmitter drives the parity bit to 0 for all characters. The receiver parity checker reports an error if the parity bit is sampled to 1. If parity is disabled, the transmitter does not generate any parity bit and the receiver does not report any parity error.

[Table 34-9](#) shows an example of the parity bit for the character 0x41 (character ASCII “A”) depending on the configuration of the USART. Because there are two bits to 1, 1 bit is added when a parity is odd, or 0 is added when a parity is even.

Table 34-9. Parity Bit Examples

Character	Hexa	Binary	Parity Bit	Parity Mode
A	0x41	0100 0001	1	Odd
A	0x41	0100 0001	0	Even
A	0x41	0100 0001	1	Mark
A	0x41	0100 0001	0	Space
A	0x41	0100 0001	None	None

When the receiver detects a parity error, it sets the PARE (Parity Error) bit in the Channel Status Register (US_CSR). The PARE bit can be cleared by writing the Control Register (US_CR) with the RSTSTA bit to 1. [Figure 34-22](#) illustrates the parity bit status setting and clearing.

Figure 34-22. Parity Error

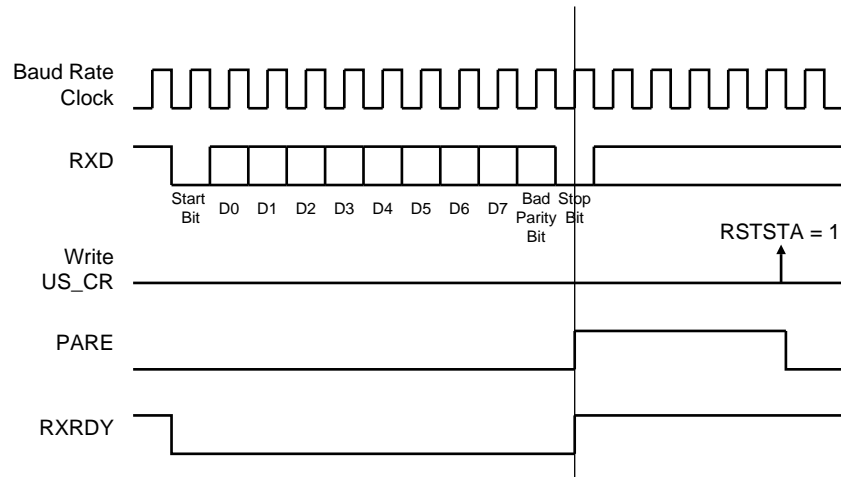

34.7.3.9 Multidrop Mode

If the PAR field in the Mode Register (US_MR) is programmed to the value 0x6 or 0x07, the USART runs in Multidrop Mode. This mode differentiates the data characters and the address characters. Data is transmitted with the parity bit to 0 and addresses are transmitted with the parity bit to 1.

If the USART is configured in multidrop mode, the receiver sets the PARE parity error bit when the parity bit is high and the transmitter is able to send a character with the parity bit high when the Control Register is written with the SENDA bit to 1.

To handle parity error, the PARE bit is cleared when the Control Register is written with the bit RSTSTA to 1.

The transmitter sends an address byte (parity bit set) when SENDA is written to US_CR. In this case, the next byte written to US_THR is transmitted as an address. Any character written in US_THR without having written the command SENDA is transmitted normally with the parity to 0.

34.7.3.10 Transmitter Timeguard

The timeguard feature enables the USART interface with slow remote devices.

The timeguard function enables the transmitter to insert an idle state on the TXD line between two characters. This idle state actually acts as a long stop bit.

The duration of the idle state is programmed in the TG field of the Transmitter Timeguard Register (US_TTGR). When this field is programmed to zero no timeguard is generated. Otherwise, the transmitter holds a high level on TXD after each transmitted byte during the number of bit periods programmed in TG in addition to the number of stop bits.

As illustrated in [Figure 34-23](#), the behavior of TXRDY and TXEMPTY status bits is modified by the programming of a timeguard. TXRDY rises only when the start bit of the next character is sent, and thus remains to 0 during the timeguard transmission if a character has been written in

US_THR. TXEMPTY remains low until the timeguard transmission is completed as the timeguard is part of the current character being transmitted.

Figure 34-23. Timeguard Operations

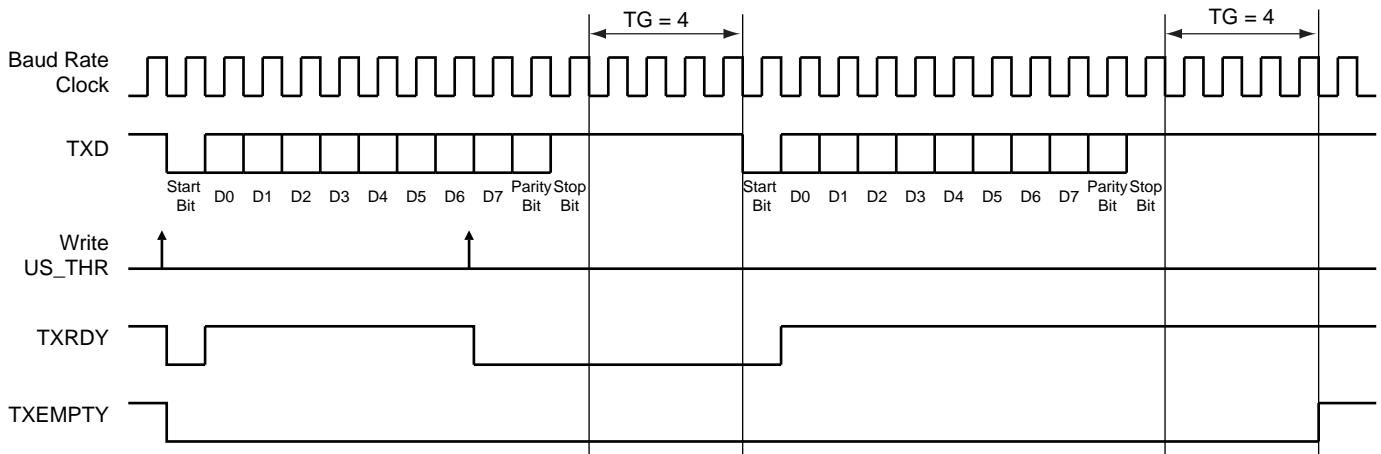

Table 34-10 indicates the maximum length of a timeguard period that the transmitter can handle in relation to the function of the Baud Rate.

Table 34-10. Maximum Timeguard Length Depending on Baud Rate

Baud Rate	Bit time	Timeguard
Bit/sec	μs	ms
1 200	833	212.50
9 600	104	26.56
14400	69.4	17.71
19200	52.1	13.28
28800	34.7	8.85
33400	29.9	7.63
56000	17.9	4.55
57600	17.4	4.43
115200	8.7	2.21

34.7.3.11 Receiver Time-out

The Receiver Time-out provides support in handling variable-length frames. This feature detects an idle condition on the RXD line. When a time-out is detected, the bit TIMEOUT in the Channel Status Register (US_CSR) rises and can generate an interrupt, thus indicating to the driver an end of frame.

The time-out delay period (during which the receiver waits for a new character) is programmed in the TO field of the Receiver Time-out Register (US_RTOR). If the TO field is programmed to 0, the Receiver Time-out is disabled and no time-out is detected. The TIMEOUT bit in US_CSR remains to 0. Otherwise, the receiver loads a 16-bit counter with the value programmed in TO. This counter is decremented at each bit period and reloaded each time a new character is received. If the counter reaches 0, the TIMEOUT bit in the Status Register rises. Then, the user can either:

- Stop the counter clock until a new character is received. This is performed by writing the Control Register (US_CR) with the STTTO (Start Time-out) bit to 1. In this case, the idle state on RXD before a new character is received will not provide a time-out. This prevents having to handle an interrupt before a character is received and allows waiting for the next idle state on RXD after a frame is received.
- Obtain an interrupt while no character is received. This is performed by writing US_CR with the RETTO (Reload and Start Time-out) bit to 1. If RETTO is performed, the counter starts counting down immediately from the value TO. This enables generation of a periodic interrupt so that a user time-out can be handled, for example when no key is pressed on a keyboard.

If STTTO is performed, the counter clock is stopped until a first character is received. The idle state on RXD before the start of the frame does not provide a time-out. This prevents having to obtain a periodic interrupt and enables a wait of the end of frame when the idle state on RXD is detected.

If RETTO is performed, the counter starts counting down immediately from the value TO. This enables generation of a periodic interrupt so that a user time-out can be handled, for example when no key is pressed on a keyboard.

Figure 34-24 shows the block diagram of the Receiver Time-out feature.

Figure 34-24. Receiver Time-out Block Diagram

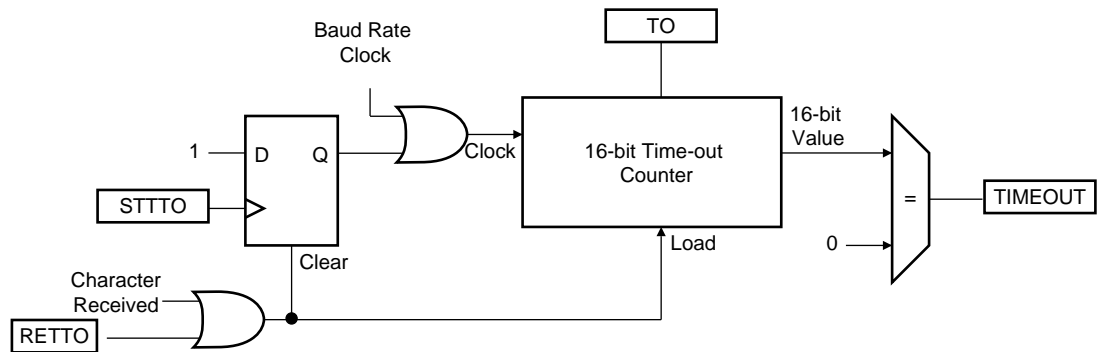

Table 34-11 gives the maximum time-out period for some standard baud rates.

Table 34-11. Maximum Time-out Period

Baud Rate	Bit Time	Time-out
bit/sec	μ s	ms
600	1 667	109 225
1 200	833	54 613
2 400	417	27 306
4 800	208	13 653
9 600	104	6 827
14400	69	4 551
19200	52	3 413
28800	35	2 276
33400	30	1 962

Table 34-11. Maximum Time-out Period (Continued)

Baud Rate	Bit Time	Time-out
56000	18	1 170
57600	17	1 138
200000	5	328

34.7.3.12 Framing Error

The receiver is capable of detecting framing errors. A framing error happens when the stop bit of a received character is detected at level 0. This can occur if the receiver and the transmitter are fully desynchronized.

A framing error is reported on the FRAME bit of the Channel Status Register (US_CSR). The FRAME bit is asserted in the middle of the stop bit as soon as the framing error is detected. It is cleared by writing the Control Register (US_CR) with the RSTSTA bit to 1.

Figure 34-25. Framing Error Status

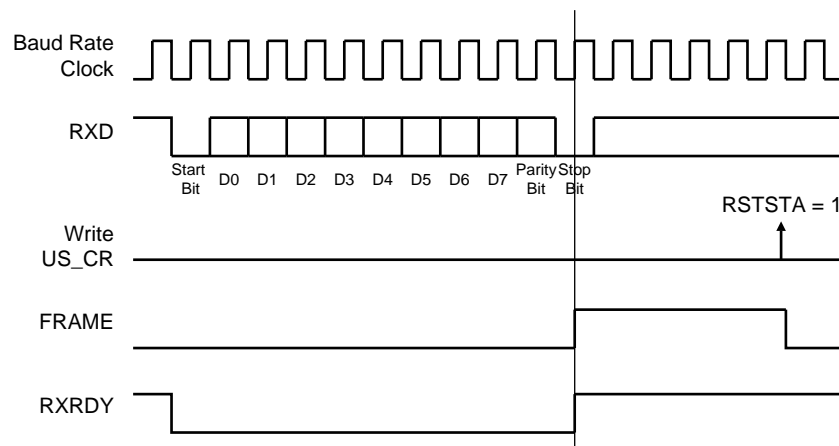

34.7.3.13 Transmit Break

The user can request the transmitter to generate a break condition on the TXD line. A break condition drives the TXD line low during at least one complete character. It appears the same as a 0x00 character sent with the parity and the stop bits to 0. However, the transmitter holds the TXD line at least during one character until the user requests the break condition to be removed.

A break is transmitted by writing the Control Register (US_CR) with the STTBK bit to 1. This can be performed at any time, either while the transmitter is empty (no character in either the Shift Register or in US_THR) or when a character is being transmitted. If a break is requested while a character is being shifted out, the character is first completed before the TXD line is held low.

Once STTBK command is requested further STTBK commands are ignored until the end of the break is completed.

The break condition is removed by writing US_CR with the STPBK bit to 1. If the STPBK is requested before the end of the minimum break duration (one character, including start, data, parity and stop bits), the transmitter ensures that the break condition completes.

The transmitter considers the break as though it is a character, i.e. the STTBK and STPBK commands are taken into account only if the TXRDY bit in US_CSR is to 1 and the start of the break condition clears the TXRDY and TXEMPTY bits as if a character is processed.

Writing US_CR with both STTBK and STPBK bits to 1 can lead to an unpredictable result. All STPBK commands requested without a previous STTBK command are ignored. A byte written into the Transmit Holding Register while a break is pending, but not started, is ignored.

After the break condition, the transmitter returns the TXD line to 1 for a minimum of 12 bit times. Thus, the transmitter ensures that the remote receiver detects correctly the end of break and the start of the next character. If the timeguard is programmed with a value higher than 12, the TXD line is held high for the timeguard period.

After holding the TXD line for this period, the transmitter resumes normal operations.

Figure 34-26 illustrates the effect of both the Start Break (STTBK) and Stop Break (STPBK) commands on the TXD line.

Figure 34-26. Break Transmission

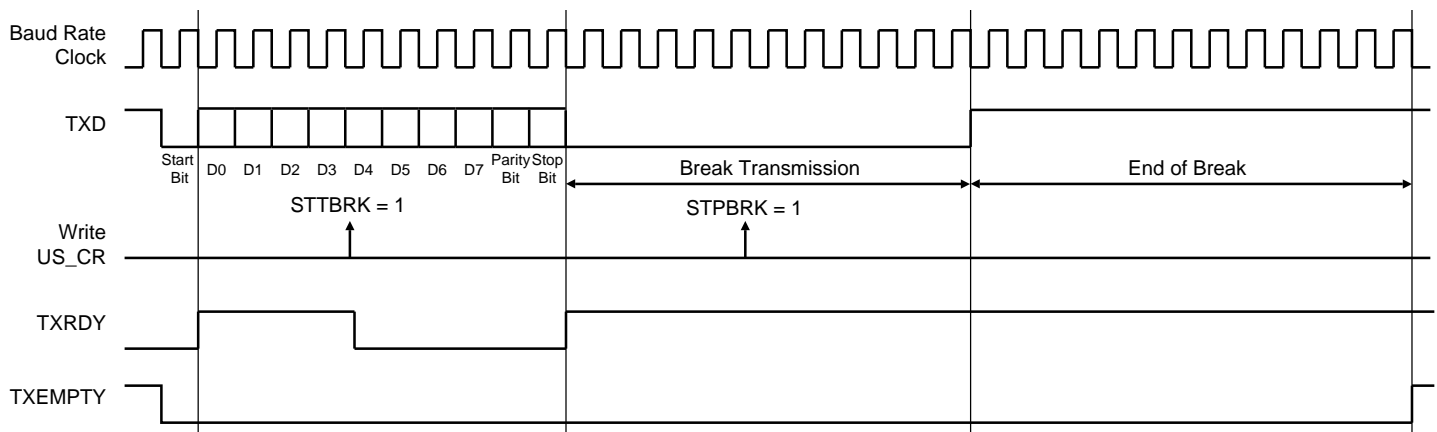

34.7.3.14 Receive Break

The receiver detects a break condition when all data, parity and stop bits are low. This corresponds to detecting a framing error with data to 0x00, but FRAME remains low.

When the low stop bit is detected, the receiver asserts the RXBRK bit in US_CSR. This bit may be cleared by writing the Control Register (US_CR) with the bit RSTSTA to 1.

An end of receive break is detected by a high level for at least 2/16 of a bit period in asynchronous operating mode or one sample at high level in synchronous operating mode. The end of break detection also asserts the RXBRK bit.

34.7.3.15 Hardware Handshaking

The USART features a hardware handshaking out-of-band flow control. The RTS and CTS pins are used to connect with the remote device, as shown in Figure 34-27.

Figure 34-27. Connection with a Remote Device for Hardware Handshaking

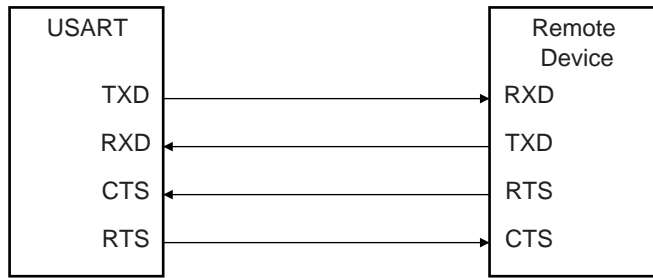

Setting the USART to operate with hardware handshaking is performed by writing the USART_MODE field in the Mode Register (US_MR) to the value 0x2.

The USART behavior when hardware handshaking is enabled is the same as the behavior in standard synchronous or asynchronous mode, except that the receiver drives the RTS pin as described below and the level on the CTS pin modifies the behavior of the transmitter as described below. Using this mode requires using the PDC channel for reception. The transmitter can handle hardware handshaking in any case.

Figure 34-28 shows how the receiver operates if hardware handshaking is enabled. The RTS pin is driven high if the receiver is disabled and if the status RXBUFF (Receive Buffer Full) coming from the PDC channel is high. Normally, the remote device does not start transmitting while its CTS pin (driven by RTS) is high. As soon as the Receiver is enabled, the RTS falls, indicating to the remote device that it can start transmitting. Defining a new buffer to the PDC clears the status bit RXBUFF and, as a result, asserts the pin RTS low.

Figure 34-28. Receiver Behavior when Operating with Hardware Handshaking

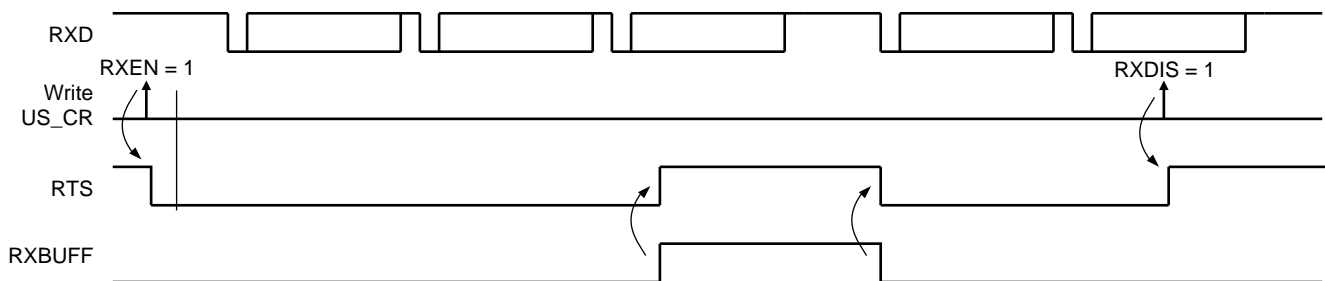

Figure 34-29 shows how the transmitter operates if hardware handshaking is enabled. The CTS pin disables the transmitter. If a character is being processing, the transmitter is disabled only after the completion of the current character and transmission of the next character happens as soon as the pin CTS falls.

Figure 34-29. Transmitter Behavior when Operating with Hardware Handshaking



34.7.4 ISO7816 Mode

The USART features an ISO7816-compatible operating mode. This mode permits interfacing with smart cards and Security Access Modules (SAM) communicating through an ISO7816 link. Both T = 0 and T = 1 protocols defined by the ISO7816 specification are supported.

Setting the USART in ISO7816 mode is performed by writing the USART_MODE field in the Mode Register (US_MR) to the value 0x4 for protocol T = 0 and to the value 0x5 for protocol T = 1.

34.7.4.1 ISO7816 Mode Overview

The ISO7816 is a half duplex communication on only one bidirectional line. The baud rate is determined by a division of the clock provided to the remote device (see [“Baud Rate Generator” on page 734](#)).

The USART connects to a smart card as shown in [Figure 34-30](#). The TXD line becomes bidirectional and the Baud Rate Generator feeds the ISO7816 clock on the SCK pin. As the TXD pin becomes bidirectional, its output remains driven by the output of the transmitter but only when the transmitter is active while its input is directed to the input of the receiver. The USART is considered as the master of the communication as it generates the clock.

Figure 34-30. Connection of a Smart Card to the USART

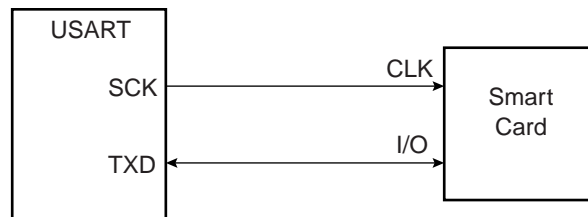

When operating in ISO7816, either in T = 0 or T = 1 modes, the character format is fixed. The configuration is 8 data bits, even parity and 1 or 2 stop bits, regardless of the values programmed in the CHRL, MODE9, PAR and CHMODE fields. MSBF can be used to transmit LSB or MSB first. Parity Bit (PAR) can be used to transmit in normal or inverse mode. Refer to [“USART Mode Register” on page 774](#) and [“PAR: Parity Type” on page 775](#).

The USART cannot operate concurrently in both receiver and transmitter modes as the communication is unidirectional at a time. It has to be configured according to the required mode by enabling or disabling either the receiver or the transmitter as desired. Enabling both the receiver and the transmitter at the same time in ISO7816 mode may lead to unpredictable results.

The ISO7816 specification defines an inverse transmission format. Data bits of the character must be transmitted on the I/O line at their negative value.

34.7.4.2 Protocol T = 0

In T = 0 protocol, a character is made up of one start bit, eight data bits, one parity bit and one guard time, which lasts two bit times. The transmitter shifts out the bits and does not drive the I/O line during the guard time.

If no parity error is detected, the I/O line remains to 1 during the guard time and the transmitter can continue with the transmission of the next character, as shown in [Figure 34-31](#).

If a parity error is detected by the receiver, it drives the I/O line to 0 during the guard time, as shown in [Figure 34-32](#). This error bit is also named NACK, for Non Acknowledge. In this case,

the character lasts 1 bit time more, as the guard time length is the same and is added to the error bit time which lasts 1 bit time.

When the USART is the receiver and it detects an error, it does not load the erroneous character in the Receive Holding Register (US_RHR). It appropriately sets the PARE bit in the Status Register (US_SR) so that the software can handle the error.

Figure 34-31. T = 0 Protocol without Parity Error

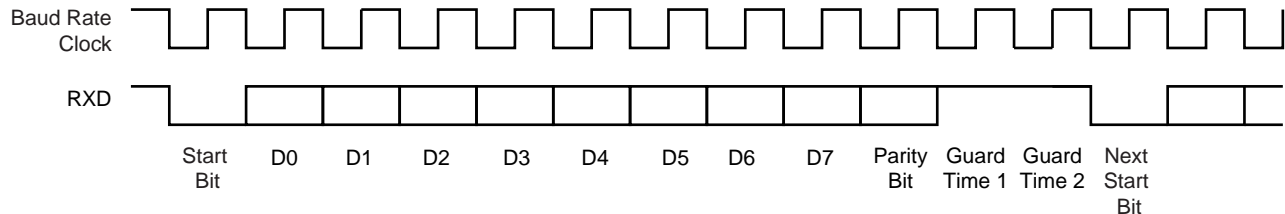
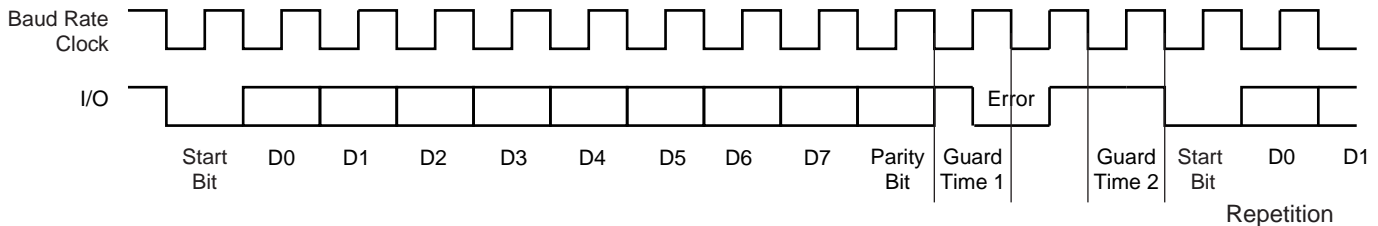

Figure 34-32. T = 0 Protocol with Parity Error



Receive Error Counter

The USART receiver also records the total number of errors. This can be read in the Number of Error (US_NER) register. The NB_ERRORS field can record up to 255 errors. Reading US_NER automatically clears the NB_ERRORS field.

Receive NACK Inhibit

The USART can also be configured to inhibit an error. This can be achieved by setting the INACK bit in the Mode Register (US_MR). If INACK is to 1, no error signal is driven on the I/O line even if a parity bit is detected.

Moreover, if INACK is set, the erroneous received character is stored in the Receive Holding Register, as if no error occurred and the RXRDY bit does rise.

Transmit Character Repetition

When the USART is transmitting a character and gets a NACK, it can automatically repeat the character before moving on to the next one. Repetition is enabled by writing the MAX_ITERATION field in the Mode Register (US_MR) at a value higher than 0. Each character can be transmitted up to eight times; the first transmission plus seven repetitions.

If MAX_ITERATION does not equal zero, the USART repeats the character as many times as the value loaded in MAX_ITERATION.

When the USART repetition number reaches MAX_ITERATION, the ITERATION bit is set in the Channel Status Register (US_CSR). If the repetition of the character is acknowledged by the receiver, the repetitions are stopped and the iteration counter is cleared.

The ITERATION bit in US_CSR can be cleared by writing the Control Register with the RSIT bit to 1.

Disable Successive Receive NACK

The receiver can limit the number of successive NACKs sent back to the remote transmitter. This is programmed by setting the bit DSNACK in the Mode Register (US_MR). The maximum number of NACK transmitted is programmed in the MAX_ITERATION field. As soon as MAX_ITERATION is reached, the character is considered as correct, an acknowledge is sent on the line and the ITERATION bit in the Channel Status Register is set.

34.7.4.3 Protocol T = 1

When operating in ISO7816 protocol T = 1, the transmission is similar to an asynchronous format with only one stop bit. The parity is generated when transmitting and checked when receiving. Parity error detection sets the PARE bit in the Channel Status Register (US_CSR).

34.7.5 IrDA Mode

The USART features an IrDA mode supplying half-duplex point-to-point wireless communication. It embeds the modulator and demodulator which allows a glueless connection to the infrared transceivers, as shown in [Figure 34-33](#). The modulator and demodulator are compliant with the IrDA specification version 1.1 and support data transfer speeds ranging from 2.4 Kb/s to 115.2 Kb/s.

The USART IrDA mode is enabled by setting the USART_MODE field in the Mode Register (US_MR) to the value 0x8. The IrDA Filter Register (US_IF) allows configuring the demodulator filter. The USART transmitter and receiver operate in a normal asynchronous mode and all parameters are accessible. Note that the modulator and the demodulator are activated.

Figure 34-33. Connection to IrDA Transceivers

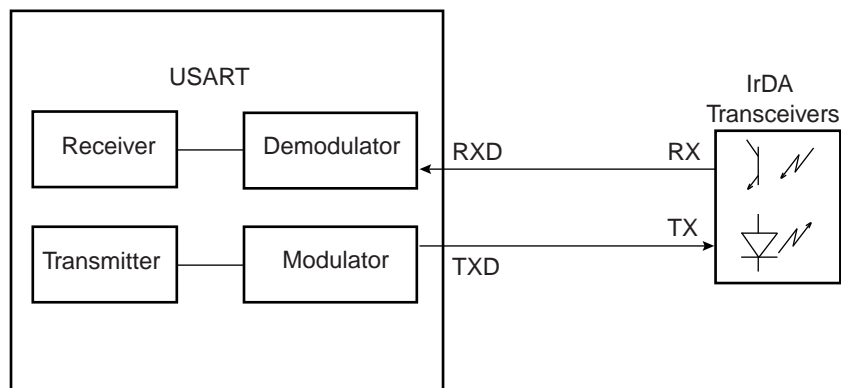

The receiver and the transmitter must be enabled or disabled according to the direction of the transmission to be managed.

To receive IrDA signals, the following needs to be done:

- Disable TX and Enable RX
- Configure the TXD pin as PIO and set it as an output to 0 (to avoid LED emission). Disable the internal pull-up (better for power consumption).
- Receive data

34.7.5.1 IrDA Modulation

For baud rates up to and including 115.2 Kbits/sec, the RZI modulation scheme is used. “0” is represented by a light pulse of 3/16th of a bit time. Some examples of signal pulse duration are shown in [Table 34-12](#).

Table 34-12. IrDA Pulse Duration

Baud Rate	Pulse Duration (3/16)
2.4 Kb/s	78.13 μ s
9.6 Kb/s	19.53 μ s
19.2 Kb/s	9.77 μ s
38.4 Kb/s	4.88 μ s
57.6 Kb/s	3.26 μ s
115.2 Kb/s	1.63 μ s

[Figure 34-34](#) shows an example of character transmission.

Figure 34-34. IrDA Modulation

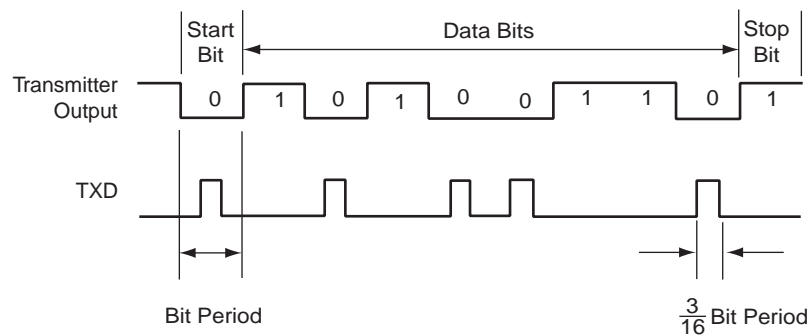

34.7.5.2 IrDA Baud Rate

[Table 34-13](#) gives some examples of CD values, baud rate error and pulse duration. Note that the requirement on the maximum acceptable error of $\pm 1.87\%$ must be met.

Table 34-13. IrDA Baud Rate Error

Peripheral Clock	Baud Rate	CD	Baud Rate Error	Pulse Time
3 686 400	115 200	2	0.00%	1.63
20 000 000	115 200	11	1.38%	1.63
32 768 000	115 200	18	1.25%	1.63
40 000 000	115 200	22	1.38%	1.63
3 686 400	57 600	4	0.00%	3.26
20 000 000	57 600	22	1.38%	3.26
32 768 000	57 600	36	1.25%	3.26
40 000 000	57 600	43	0.93%	3.26
3 686 400	38 400	6	0.00%	4.88
20 000 000	38 400	33	1.38%	4.88

Table 34-13. IrDA Baud Rate Error (Continued)

Peripheral Clock	Baud Rate	CD	Baud Rate Error	Pulse Time
32 768 000	38 400	53	0.63%	4.88
40 000 000	38 400	65	0.16%	4.88
3 686 400	19 200	12	0.00%	9.77
20 000 000	19 200	65	0.16%	9.77
32 768 000	19 200	107	0.31%	9.77
40 000 000	19 200	130	0.16%	9.77
3 686 400	9 600	24	0.00%	19.53
20 000 000	9 600	130	0.16%	19.53
32 768 000	9 600	213	0.16%	19.53
40 000 000	9 600	260	0.16%	19.53
3 686 400	2 400	96	0.00%	78.13
20 000 000	2 400	521	0.03%	78.13
32 768 000	2 400	853	0.04%	78.13

34.7.5.3 IrDA Demodulator

The demodulator is based on the IrDA Receive filter comprised of an 8-bit down counter which is loaded with the value programmed in US_IF. When a falling edge is detected on the RXD pin, the Filter Counter starts counting down at the Master Clock (MCK) speed. If a rising edge is detected on the RXD pin, the counter stops and is reloaded with US_IF. If no rising edge is detected when the counter reaches 0, the input of the receiver is driven low during one bit time.

Figure 34-35 illustrates the operations of the IrDA demodulator.

Figure 34-35. IrDA Demodulator Operations

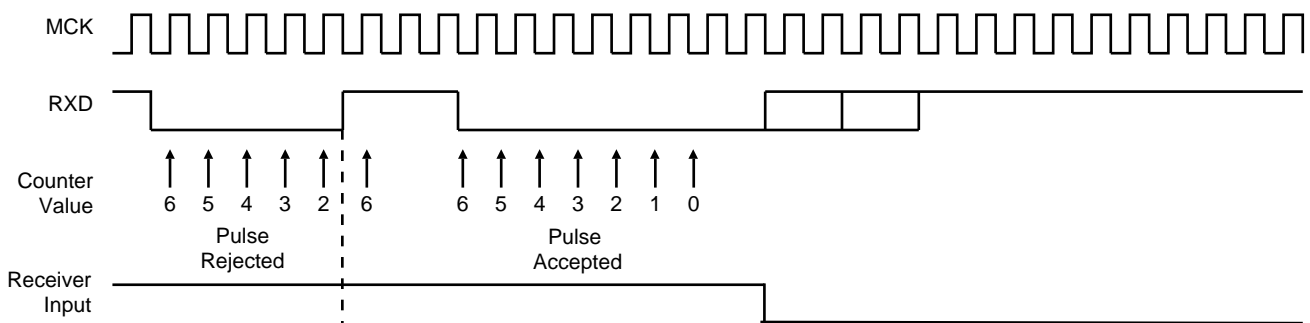

As the IrDA mode uses the same logic as the ISO7816, note that the FI_DI_RATIO field in US_FIDI must be set to a value higher than 0 in order to assure IrDA communications operate correctly.

34.7.6 RS485 Mode

The USART features the RS485 mode to enable line driver control. While operating in RS485 mode, the USART behaves as though in asynchronous or synchronous mode and configuration of all the parameters is possible. The difference is that the RTS pin is driven high when the transmitter is operating. The behavior of the RTS pin is controlled by the TXEMPTY bit. A typical connection of the USART to a RS485 bus is shown in [Figure 34-36](#).

Figure 34-36. Typical Connection to a RS485 Bus

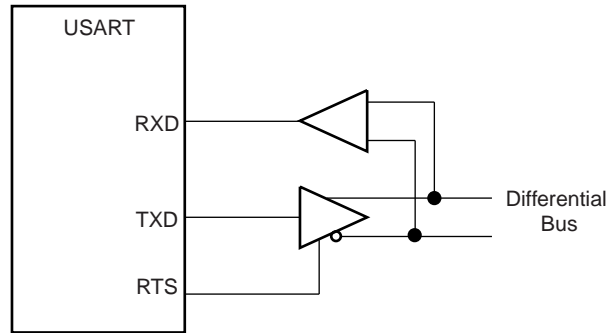

The USART is set in RS485 mode by programming the USART_MODE field in the Mode Register (US_MR) to the value 0x1.

The RTS pin is at a level inverse to the TXEMPTY bit. Significantly, the RTS pin remains high when a timeguard is programmed so that the line can remain driven after the last character completion. [Figure 34-37](#) gives an example of the RTS waveform during a character transmission when the timeguard is enabled.

Figure 34-37. Example of RTS Drive with Timeguard

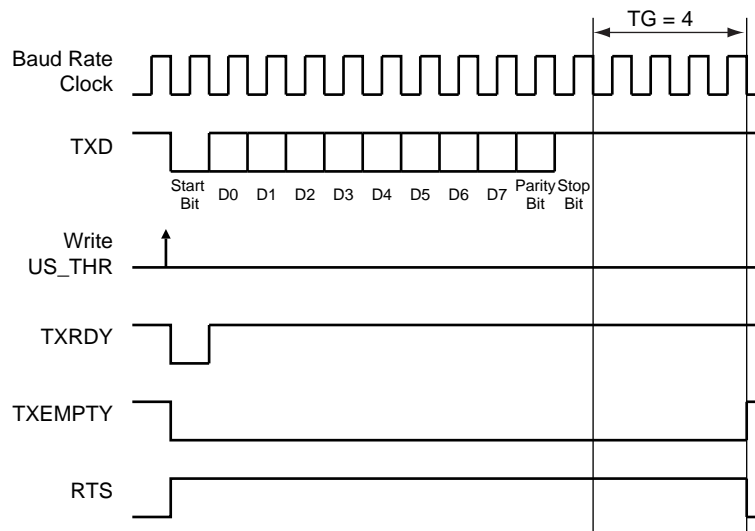

34.7.7 Modem Mode

The USART features modem mode, which enables control of the signals: DTR (Data Terminal Ready), DSR (Data Set Ready), RTS (Request to Send), CTS (Clear to Send), DCD (Data Carrier Detect) and RI (Ring Indicator). While operating in modem mode, the USART behaves as a DTE (Data Terminal Equipment) as it drives DTR and RTS and can detect level change on DSR, DCD, CTS and RI.

Setting the USART in modem mode is performed by writing the USART_MODE field in the Mode Register (US_MR) to the value 0x3. While operating in modem mode the USART behaves as though in asynchronous mode and all the parameter configurations are available.

Table 34-14 gives the correspondence of the USART signals with modem connection standards.

Table 34-14. Circuit References

USART Pin	V24	CCITT	Direction
TXD	2	103	From terminal to modem
RTS	4	105	From terminal to modem
DTR	20	108.2	From terminal to modem
RXD	3	104	From modem to terminal
CTS	5	106	From terminal to modem
DSR	6	107	From terminal to modem
DCD	8	109	From terminal to modem
RI	22	125	From terminal to modem

The control of the DTR output pin is performed by writing the Control Register (US_CR) with the DTRDIS and DTREN bits respectively to 1. The disable command forces the corresponding pin to its inactive level, i.e. high. The enable command forces the corresponding pin to its active level, i.e. low. RTS output pin is automatically controlled in this mode

The level changes are detected on the RI, DSR, DCD and CTS pins. If an input change is detected, the RIIC, DSRIC, DCDIC and CTSIC bits in the Channel Status Register (US_CSR) are set respectively and can trigger an interrupt. The status is automatically cleared when US_CSR is read. Furthermore, the CTS automatically disables the transmitter when it is detected at its inactive state. If a character is being transmitted when the CTS rises, the character transmission is completed before the transmitter is actually disabled.

34.7.8 SPI Mode

The Serial Peripheral Interface (SPI) Mode is a synchronous serial data link that provides communication with external devices in Master or Slave Mode. It also enables communication between processors if an external processor is connected to the system.

The Serial Peripheral Interface is essentially a shift register that serially transmits data bits to other SPIs. During a data transfer, one SPI system acts as the “master” which controls the data flow, while the other devices act as “slaves” which have data shifted into and out by the master. Different CPUs can take turns being masters and one master may simultaneously shift data into multiple slaves. (Multiple Master Protocol is the opposite of Single Master Protocol, where one CPU is always the master while all of the others are always slaves.) However, only one slave may drive its output to write data back to the master at any given time.

A slave device is selected when its NSS signal is asserted by the master. The USART in SPI Master mode can address only one SPI Slave because it can generate only one NSS signal.

The SPI system consists of two data lines and two control lines:

- Master Out Slave In (MOSI): This data line supplies the output data from the master shifted into the input of the slave.
- Master In Slave Out (MISO): This data line supplies the output data from a slave to the input of the master.
- Serial Clock (SCK): This control line is driven by the master and regulates the flow of the data bits. The master may transmit data at a variety of baud rates. The SCK line cycles once for each bit that is transmitted.
- Slave Select (NSS): This control line allows the master to select or deselect the slave.

34.7.8.1 Modes of Operation

The USART can operate in SPI Master Mode or in SPI Slave Mode.

Operation in SPI Master Mode is programmed by writing to 0xE the USART_MODE field in the Mode Register. In this case the SPI lines must be connected as described below:

- The MOSI line is driven by the output pin TXD
- The MISO line drives the input pin RXD
- The SCK line is driven by the output pin SCK
- The NSS line is driven by the output pin RTS

Operation in SPI Slave Mode is programmed by writing to 0xF the USART_MODE field in the Mode Register. In this case the SPI lines must be connected as described below:

- The MOSI line drives the input pin RXD
- The MISO line is driven by the output pin TXD
- The SCK line drives the input pin SCK
- The NSS line drives the input pin CTS

In order to avoid unpredicted behavior, any change of the SPI Mode must be followed by a software reset of the transmitter and of the receiver (except the initial configuration after a hardware reset).

34.7.8.2 Baud Rate

In SPI Mode, the baudrate generator operates in the same way as in USART synchronous mode: See “Baud Rate in Synchronous Mode or SPI Mode” on page 736. However, there are some restrictions:

In SPI Master Mode:

- The external clock SCK must not be selected ($USCLKS \neq 0x3$), and the bit CLKO must be set to “1” in the Mode Register (US_MR), in order to generate correctly the serial clock on the SCK pin.
- To obtain correct behavior of the receiver and the transmitter, the value programmed in CD must be superior or equal to 6.
- If the internal clock divided (MCK/DIV) is selected, the value programmed in CD must be even to ensure a 50:50 mark/space ratio on the SCK pin, this value can be odd if the internal clock is selected (MCK).

In SPI Slave Mode:

- The external clock (SCK) selection is forced regardless of the value of the USCLKS field in the Mode Register (US_MR). Likewise, the value written in US_BRGR has no effect, because the clock is provided directly by the signal on the USART SCK pin.
- To obtain correct behavior of the receiver and the transmitter, the external clock (SCK) frequency must be at least 6 times lower than the system clock.

34.7.8.3 Data Transfer

Up to 9 data bits are successively shifted out on the TXD pin at each rising or falling edge (depending of CPOL and CPHA) of the programmed serial clock. There is no Start bit, no Parity bit and no Stop bit.

The number of data bits is selected by the CHRL field and the MODE 9 bit in the Mode Register (US_MR). The 9 bits are selected by setting the MODE 9 bit regardless of the CHRL field. The MSB data bit is always sent first in SPI Mode (Master or Slave).

Four combinations of polarity and phase are available for data transfers. The clock polarity is programmed with the CPOL bit in the Mode Register. The clock phase is programmed with the CPHA bit. These two parameters determine the edges of the clock signal upon which data is driven and sampled. Each of the two parameters has two possible states, resulting in four possible combinations that are incompatible with one another. Thus, a master/slave pair must use the same parameter pair values to communicate. If multiple slaves are used and fixed in different configurations, the master must reconfigure itself each time it needs to communicate with a different slave.

Table 34-15. SPI Bus Protocol Mode

SPI Bus Protocol Mode	CPOL	CPHA
0	0	1
1	0	0
2	1	1
3	1	0

Figure 34-38. SPI Transfer Format (CPHA=1, 8 bits per transfer)

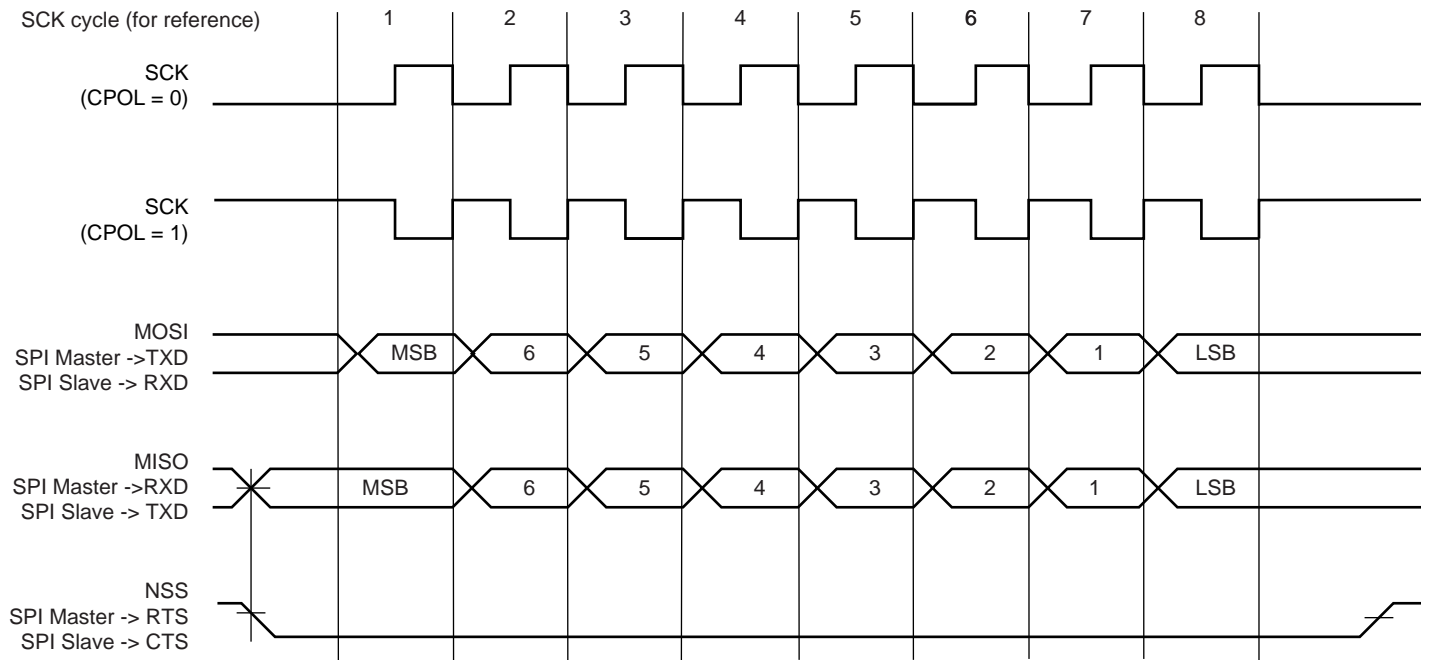
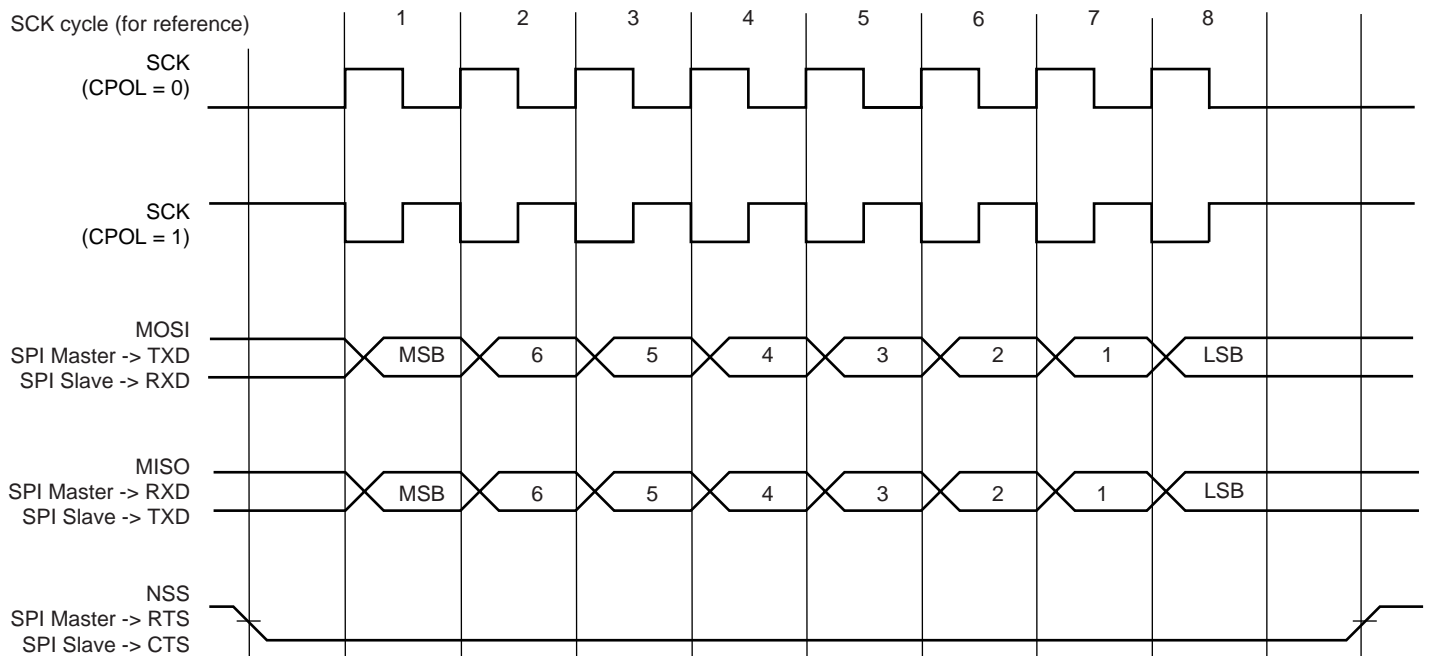

Figure 34-39. SPI Transfer Format (CPHA=0, 8 bits per transfer)



34.7.8.4 Receiver and Transmitter Control

See “Receiver and Transmitter Control” on page 738.

34.7.8.5 Character Transmission

The characters are sent by writing in the Transmit Holding Register (US_THR). An additional condition for transmitting a character can be added when the USART is configured in SPI master mode. In the USART_MR register, the value configured on INACK field can prevent any character transmission (even if US_THR has been written) while the receiver side is not ready (character not read). When WRDBT equals 0, the character is transmitted whatever the receiver status. If WRDBT is set to 1, the transmitter waits for the receiver holding register to be read before transmitting the character (RXRDY flag cleared), thus preventing any overflow (character loss) on the receiver side.

The transmitter reports two status bits in the Channel Status Register (US_CSR): TXRDY (Transmitter Ready), which indicates that US_THR is empty and TXEMPTY, which indicates that all the characters written in US_THR have been processed. When the current character processing is completed, the last character written in US_THR is transferred into the Shift Register of the transmitter and US_THR becomes empty, thus TXRDY rises.

Both TXRDY and TXEMPTY bits are low when the transmitter is disabled. Writing a character in US_THR while TXRDY is low has no effect and the written character is lost.

If the USART is in SPI Slave Mode and if a character must be sent while the Transmit Holding Register (US_THR) is empty, the UNRE (Underrun Error) bit is set. The TXD transmission line stays at high level during all this time. The UNRE bit is cleared by writing the Control Register (US_CR) with the RSTSTA (Reset Status) bit to 1.

In SPI Master Mode, the slave select line (NSS) is asserted at low level 1 Tbit (Time bit) before the transmission of the MSB bit and released at high level 1 Tbit after the transmission of the LSB bit. So, the slave select line (NSS) is always released between each character transmission and a minimum delay of 3 Tbits always inserted. However, in order to address slave devices supporting the CSAAT mode (Chip Select Active After Transfer), the slave select line (NSS) can be forced at low level by writing the Control Register (US_CR) with the RTSEN bit to 1. The slave select line (NSS) can be released at high level only by writing the Control Register (US_CR) with the RTSDIS bit to 1 (for example, when all data have been transferred to the slave device).

In SPI Slave Mode, the transmitter does not require a falling edge of the slave select line (NSS) to initiate a character transmission but only a low level. However, this low level must be present on the slave select line (NSS) at least 1 Tbit before the first serial clock cycle corresponding to the MSB bit.

34.7.8.6 Character Reception

When a character reception is completed, it is transferred to the Receive Holding Register (US_RHR) and the RXRDY bit in the Status Register (US_CSR) rises. If a character is completed while RXRDY is set, the OVRE (Overrun Error) bit is set. The last character is transferred into US_RHR and overwrites the previous one. The OVRE bit is cleared by writing the Control Register (US_CR) with the RSTSTA (Reset Status) bit to 1.

To ensure correct behavior of the receiver in SPI Slave Mode, the master device sending the frame must ensure a minimum delay of 1 Tbit between each character transmission. The receiver does not require a falling edge of the slave select line (NSS) to initiate a character

reception but only a low level. However, this low level must be present on the slave select line (NSS) at least 1 Tbit before the first serial clock cycle corresponding to the MSB bit.

34.7.8.7 Receiver Timeout

Because the receiver baudrate clock is active only during data transfers in SPI Mode, a receiver timeout is impossible in this mode, whatever the Time-out value is (field TO) in the Time-out Register (US_RTOR).

34.7.9 Test Modes

The USART can be programmed to operate in three different test modes. The internal loopback capability allows on-board diagnostics. In the loopback mode the USART interface pins are disconnected or not and reconfigured for loopback internally or externally.

34.7.9.1 Normal Mode

Normal mode connects the RXD pin on the receiver input and the transmitter output on the TXD pin.

Figure 34-40. Normal Mode Configuration

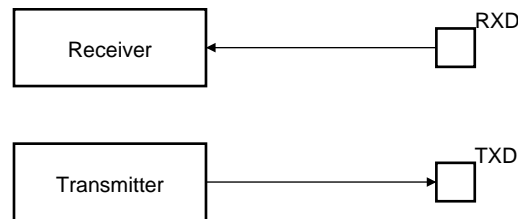

34.7.9.2 Automatic Echo Mode

Automatic echo mode allows bit-by-bit retransmission. When a bit is received on the RXD pin, it is sent to the TXD pin, as shown in [Figure 34-41](#). Programming the transmitter has no effect on the TXD pin. The RXD pin is still connected to the receiver input, thus the receiver remains active.

Figure 34-41. Automatic Echo Mode Configuration

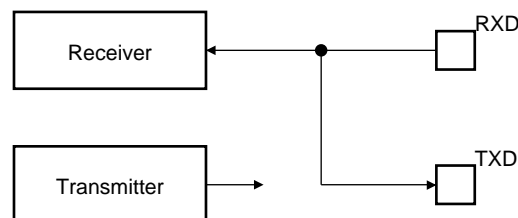

34.7.9.3 Local Loopback Mode

Local loopback mode connects the output of the transmitter directly to the input of the receiver, as shown in [Figure 34-42](#). The TXD and RXD pins are not used. The RXD pin has no effect on the receiver and the TXD pin is continuously driven high, as in idle state.

Figure 34-42. Local Loopback Mode Configuration

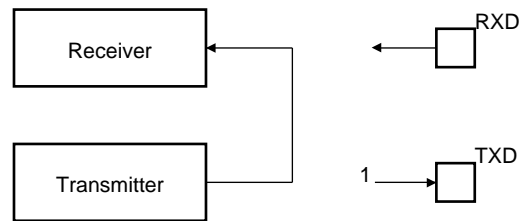

34.7.9.4 Remote Loopback Mode

Remote loopback mode directly connects the RXD pin to the TXD pin, as shown in [Figure 34-43](#). The transmitter and the receiver are disabled and have no effect. This mode allows bit-by-bit retransmission.

Figure 34-43. Remote Loopback Mode Configuration

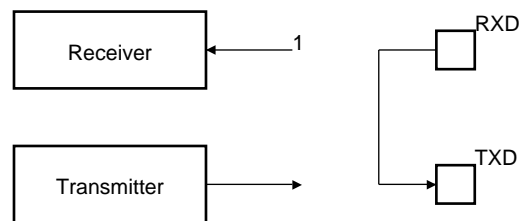

34.7.10 Write Protection Registers

To prevent any single software error that may corrupt USART behavior, certain address spaces can be write-protected by setting the WPEN bit in the USART Write Protect Mode Register (US_WPMR).

If a write access to the protected registers is detected, then the WPVS flag in the USART Write Protect Status Register (US_WPSR) is set and the field WPVSR indicates in which register the write access has been attempted.

The WPVS flag is automatically reset by reading the USART Write Protect Mode Register (US_WPMR) with the appropriate access key, WPKEY.

The protected registers are:

- “USART Mode Register”
- “USART Baud Rate Generator Register”
- “USART Receiver Time-out Register”
- “USART Transmitter Timeguard Register”
- “USART FI DI RATIO Register”
- “USART IrDA FILTER Register”
- “USART Manchester Configuration Register”

34.8 Universal Synchronous Asynchronous Receiver Transceiver (USART) User Interface

Table 34-16. Register Mapping

Offset	Register	Name	Access	Reset
0x0000	Control Register	US_CR	Write-only	–
0x0004	Mode Register	US_MR	Read-write	–
0x0008	Interrupt Enable Register	US_IER	Write-only	–
0x000C	Interrupt Disable Register	US_IDR	Write-only	–
0x0010	Interrupt Mask Register	US_IMR	Read-only	0x0
0x0014	Channel Status Register	US_CSR	Read-only	–
0x0018	Receiver Holding Register	US_RHR	Read-only	0x0
0x001C	Transmitter Holding Register	US_THR	Write-only	–
0x0020	Baud Rate Generator Register	US_BRGR	Read-write	0x0
0x0024	Receiver Time-out Register	US_RTOR	Read-write	0x0
0x0028	Transmitter Timeguard Register	US_TTGR	Read-write	0x0
0x2C - 0x3C	Reserved	–	–	–
0x0040	FI DI Ratio Register	US_FIDI	Read-write	0x174
0x0044	Number of Errors Register	US_NER	Read-only	–
0x0048	Reserved	–	–	–
0x004C	IrDA Filter Register	US_IF	Read-write	0x0
0x0050	Manchester Encoder Decoder Register	US_MAN	Read-write	0xB0011004
0xE4	Write Protect Mode Register	US_WPMR	Read-write	0x0
0xE8	Write Protect Status Register	US_WPSR	Read-only	0x0
0x5C - 0xFC	Reserved	–	–	–
0x100 - 0x128	Reserved for PDC Registers	–	–	–

34.8.1 USART Control Register

Name: US_CR

Address: 0x40024000 (0), 0x40028000 (1)

Access: Write-only

31	30	29	28	27	26	25	24
–	–	–	–	–	–	–	–
23	22	21	20	19	18	17	16
–	–	–	–	RTSDIS	RTSEN	DTRDIS	DTREN
15	14	13	12	11	10	9	8
RETTO	RSTNACK	RSTIT	SENDA	STTTO	STPBRK	STTBRK	RSTSTA
7	6	5	4	3	2	1	0
TXDIS	TXEN	RXDIS	RXEN	RSTTX	RSTRX	–	–

For SPI control, see [“USART Control Register \(SPI_MODE\)” on page 772](#).

- **RSTRX: Reset Receiver**

0: No effect.

1: Resets the receiver.

- **RSTTX: Reset Transmitter**

0: No effect.

1: Resets the transmitter.

- **RXEN: Receiver Enable**

0: No effect.

1: Enables the receiver, if RXDIS is 0.

- **RXDIS: Receiver Disable**

0: No effect.

1: Disables the receiver.

- **TXEN: Transmitter Enable**

0: No effect.

1: Enables the transmitter if TXDIS is 0.

- **TXDIS: Transmitter Disable**

0: No effect.

1: Disables the transmitter.

- **RSTSTA: Reset Status Bits**

0: No effect.

1: Resets the status bits PARE, FRAME, OVRE, MANERR and RXBRK in US_CSR.

- **STTBK: Start Break**

0: No effect.

1: Starts transmission of a break after the characters present in US_THR and the Transmit Shift Register have been transmitted. No effect if a break is already being transmitted.

- **STPBK: Stop Break**

0: No effect.

1: Stops transmission of the break after a minimum of one character length and transmits a high level during 12-bit periods. No effect if no break is being transmitted.

- **STTTO: Start Time-out**

0: No effect.

1: Starts waiting for a character before clocking the time-out counter. Resets the status bit TIMEOUT in US_CSR.

- **SENDA: Send Address**

0: No effect.

1: In Multidrop Mode only, the next character written to the US_THR is sent with the address bit set.

- **RSTIT: Reset Iterations**

0: No effect.

1: Resets ITERATION in US_CSR. No effect if the ISO7816 is not enabled.

- **RSTNACK: Reset Non Acknowledge**

0: No effect

1: Resets NACK in US_CSR.

- **RETTO: Rearm Time-out**

0: No effect

1: Restart Time-out

- **DTREN: Data Terminal Ready Enable**

0: No effect.

1: Drives the pin DTR to 0.

- **DTRDIS: Data Terminal Ready Disable**

0: No effect.

1: Drives the pin DTR to 1.

- **RTSEN: Request to Send Enable**

0: No effect.

1: Drives the pin RTS to 0.

- **RTSDIS: Request to Send Disable**

0: No effect.

1: Drives the pin RTS to 1.

34.8.2 USART Control Register (SPI_MODE)

Name: US_CR (SPI_MODE)
Address: 0x40024000 (0), 0x40028000 (1)
Access: Write-only

31	30	29	28	27	26	25	24
–	–	–	–	–	–	–	–
23	22	21	20	19	18	17	16
–	–	–	–	RCS	FCS	–	–
15	14	13	12	11	10	9	8
–	–	–	–	–	–	–	RSTSTA
7	6	5	4	3	2	1	0
TXDIS	TXEN	RXDIS	RXEN	RSTTX	RSTRX	–	–

This configuration is relevant only if USART_MODE=0xE or 0xF in [“USART Mode Register” on page 774](#).

- **RSTRX: Reset Receiver**

0: No effect.
 1: Resets the receiver.

- **RSTTX: Reset Transmitter**

0: No effect.
 1: Resets the transmitter.

- **RXEN: Receiver Enable**

0: No effect.
 1: Enables the receiver, if RXDIS is 0.

- **RXDIS: Receiver Disable**

0: No effect.
 1: Disables the receiver.

- **TXEN: Transmitter Enable**

0: No effect.
 1: Enables the transmitter if TXDIS is 0.

- **TXDIS: Transmitter Disable**

0: No effect.
 1: Disables the transmitter.

- **RSTSTA: Reset Status Bits**

0: No effect.

1: Resets the status bits OVRE, UNRE in US_CSR.

- **FCS: Force SPI Chip Select**

– Applicable if USART operates in SPI Master Mode (USART_MODE = 0xE):

FCS = 0: No effect.

FCS = 1: Forces the Slave Select Line NSS (RTS pin) to 0, even if USART is not transmitting, in order to address SPI slave devices supporting the CSAAT Mode (Chip Select Active After Transfer).

- **RCS: Release SPI Chip Select**

– Applicable if USART operates in SPI Master Mode (USART_MODE = 0xE):

RCS = 0: No effect.

RCS = 1: Releases the Slave Select Line NSS (RTS pin).



34.8.3 USART Mode Register

Name: US_MR

Address: 0x40024004 (0), 0x40028004 (1)

Access: Read-write

31	30	29	28	27	26	25	24
ONEBIT	MODSYNC	MAN	FILTER	–	MAX_ITERATION		
23	22	21	20	19	18	17	16
INVDATA	VAR_SYNC	DSNACK	INACK	OVER	CLKO	MODE9	MSBF
15	14	13	12	11	10	9	8
CHMODE		NBSTOP			PAR		SYNC
7	6	5	4	3	2	1	0
CHRL		USCLKS			USART_MODE		

This register can only be written if the WPEN bit is cleared in “USART Write Protect Mode Register” on page 803.

For SPI configuration, see “USART Mode Register (SPI_MODE)” on page 778.

• USART_MODE: USART Mode of Operation

Value	Name	Description
0x0	NORMAL	Normal mode
0x1	RS485	RS485
0x2	HW_HANDSHAKING	Hardware Handshaking
0x3	MODEM	Modem
0x4	IS07816_T_0	IS07816 Protocol: T = 0
0x6	IS07816_T_1	IS07816 Protocol: T = 1
0x8	IRDA	IrDA
0xE	SPI_MASTER	SPI Master
0xF	SPI_SLAVE	SPI Slave

• USCLKS: Clock Selection

Value	Name	Description
0	MCK	Master Clock MCK is selected
1	DIV	Internal Clock Divided MCK/DIV (DIV=8) is selected
3	SCK	Serial Clock SLK is selected

- **CHRL: Character Length.**

Value	Name	Description
0	5_BIT	Character length is 5 bits
1	6_BIT	Character length is 6 bits
2	7_BIT	Character length is 7 bits
3	8_BIT	Character length is 8 bits

- **SYNC: Synchronous Mode Select**

0: USART operates in Asynchronous Mode.

1: USART operates in Synchronous Mode.

- **PAR: Parity Type**

Value	Name	Description
0	EVEN	Even parity
1	ODD	Odd parity
2	SPACE	Parity forced to 0 (Space)
3	MARK	Parity forced to 1 (Mark)
4	NO	No parity
6	MULTIDROP	Multidrop mode

- **NBSTOP: Number of Stop Bits**

Value	Name	Description
0	1_BIT	1 stop bit
1	1_5_BIT	1.5 stop bit (SYNC = 0) or reserved (SYNC = 1)
2	2_BIT	2 stop bits

- **CHMODE: Channel Mode**

Value	Name	Description
0	NORMAL	Normal Mode
1	AUTOMATIC	Automatic Echo. Receiver input is connected to the TXD pin.
2	LOCAL_LOOPBACK	Local Loopback. Transmitter output is connected to the Receiver Input.
3	REMOTE_LOOPBACK	Remote Loopback. RXD pin is internally connected to the TXD pin.

- **MSBF: Bit Order**

0: Least Significant Bit is sent/received first.

1: Most Significant Bit is sent/received first.

- **MODE9: 9-bit Character Length**

0: CHRL defines character length.

1: 9-bit character length.

- **CLKO: Clock Output Select**

0: The USART does not drive the SCK pin.

1: The USART drives the SCK pin if USCLKS does not select the external clock SCK.

- **OVER: Oversampling Mode**

0: 16x Oversampling.

1: 8x Oversampling.

- **INACK: Inhibit Non Acknowledge**

0: The NACK is generated.

1: The NACK is not generated.

- **DSNACK: Disable Successive NACK**

0: NACK is sent on the ISO line as soon as a parity error occurs in the received character (unless INACK is set).

1: Successive parity errors are counted up to the value specified in the MAX_ITERATION field. These parity errors generate a NACK on the ISO line. As soon as this value is reached, no additional NACK is sent on the ISO line. The flag ITERATION is asserted.

- **INVDATA: INverted Data**

0: The data field transmitted on TXD line is the same as the one written in US_THR register or the content read in US_RHR is the same as RXD line. Normal mode of operation.

1: The data field transmitted on TXD line is inverted (voltage polarity only) compared to the value written on US_THR register or the content read in US_RHR is inverted compared to what is received on RXD line (or ISO7816 IO line). Inverted Mode of operation, useful for contactless card application. To be used with configuration bit MSBF.

- **VAR_SYNC: Variable Synchronization of Command/Data Sync Start Frame Delimiter**

0: User defined configuration of command or data sync field depending on MODSYNC value.

1: The sync field is updated when a character is written into US_THR register.

- **MAX_ITERATION: Maximum Number of Automatic Iteration**

0 - 7: Defines the maximum number of iterations in mode ISO7816, protocol T= 0.

- **FILTER: Infrared Receive Line Filter**

0: The USART does not filter the receive line.

1: The USART filters the receive line using a three-sample filter (1/16-bit clock) (2 over 3 majority).

- **MAN: Manchester Encoder/Decoder Enable**

0: Manchester Encoder/Decoder are disabled.

1: Manchester Encoder/Decoder are enabled.

- **MODSYNC: Manchester Synchronization Mode**

0: The Manchester Start bit is a 0 to 1 transition

1: The Manchester Start bit is a 1 to 0 transition.

- **ONEBIT: Start Frame Delimiter Selector**

0: Start Frame delimiter is COMMAND or DATA SYNC.

1: Start Frame delimiter is One Bit.

34.8.4 USART Mode Register (SPI_MODE)

Name: US_MR (SPI_MODE)
Address: 0x40024004 (0), 0x40028004 (1)
Access: Read-write

31	30	29	28	27	26	25	24
–	–	–	–	–	–	–	–
23	22	21	20	19	18	17	16
–	–	–	WRDBT		–		CPOL
15	14	13	12	11	10	9	8
–	–	–	–	–	–	–	CPHA
7	6	5	4	3	2	1	0
CHRL		USCLKS		USART_MODE			

This configuration is relevant only if USART_MODE=0xE or 0xF in “USART Mode Register” on page 774.

This register can only be written if the WPEN bit is cleared in “USART Write Protect Mode Register” on page 803.

- **USART_MODE: USART Mode of Operation**

Value	Name	Description
0xE	SPI_MASTER	SPI Master
0xF	SPI_SLAVE	SPI Slave

- **USCLKS: Clock Selection**

Value	Name	Description
0	MCK	Master Clock MCK is selected
1	DIV	Internal Clock Divided MCK/DIV (DIV=8) is selected
3	SCK	Serial Clock SLK is selected

- **CHRL: Character Length.**

Value	Name	Description
3	8_BIT	Character length is 8 bits

- **CPHA: SPI Clock Phase**

– Applicable if USART operates in SPI Mode (USART_MODE = 0xE or 0xF):

CPHA = 0: Data is changed on the leading edge of SPCK and captured on the following edge of SPCK.

CPHA = 1: Data is captured on the leading edge of SPCK and changed on the following edge of SPCK.

CPHA determines which edge of SPCK causes data to change and which edge causes data to be captured. CPHA is used with CPOL to produce the required clock/data relationship between master and slave devices.

- **CHMODE: Channel Mode**

Value	Name	Description
0	NORMAL	Normal Mode
1	AUTOMATIC	Automatic Echo. Receiver input is connected to the TXD pin.
2	LOCAL_LOOPBACK	Local Loopback. Transmitter output is connected to the Receiver Input.
3	REMOTE_LOOPBACK	Remote Loopback. RXD pin is internally connected to the TXD pin.

- **CPOL: SPI Clock Polarity**

- Applicable if USART operates in SPI Mode (Slave or Master, USART_MODE = 0xE or 0xF):

CPOL = 0: The inactive state value of SPCK is logic level zero.

CPOL = 1: The inactive state value of SPCK is logic level one.

CPOL is used to determine the inactive state value of the serial clock (SPCK). It is used with CPHA to produce the required clock/data relationship between master and slave devices.

- **WRDBT: Wait Read Data Before Transfer**

0: the character transmission starts as soon as a character is written into US_THR register (assuming TXRDY was set).

1: The character transmission starts when a character is written and only if RXRDY flag is cleared (Receiver Holding Register has been read).

34.8.5 USART Interrupt Enable Register

Name: US_IER

Address: 0x40024008 (0), 0x40028008 (1)

Access: Write-only

31	30	29	28	27	26	25	24
–	–	–	–	–	–	–	MANE
23	22	21	20	19	18	17	16
–	–	–	–	CTSIC	DCDIC	DSRIC	RIIC
15	14	13	12	11	10	9	8
–	–	NACK	RXBUFF	TXBUFE	ITER	TXEMPTY	TIMEOUT
7	6	5	4	3	2	1	0
PARE	FRAME	OVRE	ENDTX	ENDRX	RXBRK	TXRDY	RXRDY

For SPI specific configuration, see [“USART Interrupt Enable Register \(SPI_MODE\)” on page 782](#).

- **RXRDY:** RXRDY Interrupt Enable
- **TXRDY:** TXRDY Interrupt Enable
- **RXBRK:** Receiver Break Interrupt Enable
- **ENDRX:** End of Receive Transfer Interrupt Enable (available in all USART modes of operation)
- **ENDTX:** End of Transmit Interrupt Enable (available in all USART modes of operation)
- **OVRE:** Overrun Error Interrupt Enable
- **FRAME:** Framing Error Interrupt Enable
- **PARE:** Parity Error Interrupt Enable
- **TIMEOUT:** Time-out Interrupt Enable
- **TXEMPTY:** TXEMPTY Interrupt Enable
- **ITER:** Max number of Repetitions Reached Interrupt Enable
- **TXBUFE:** Buffer Empty Interrupt Enable (available in all USART modes of operation)
- **RXBUFF:** Buffer Full Interrupt Enable (available in all USART modes of operation)
- **NACK:** Non Acknowledge Interrupt Enable
- **RIIC:** Ring Indicator Input Change Enable
- **DSRIC:** Data Set Ready Input Change Enable
- **DCDIC:** Data Carrier Detect Input Change Interrupt Enable

- **CTSIC: Clear to Send Input Change Interrupt Enable**

- **MANE: Manchester Error Interrupt Enable**

0: No effect

1: Enables the corresponding interrupt.

34.8.6 USART Interrupt Enable Register (SPI_MODE)

Name: US_IER (SPI_MODE)

Address: 0x40024008 (0), 0x40028008 (1)

Access: Write-only

31	30	29	28	27	26	25	24
–	–	–	–	–	–	–	–
23	22	21	20	19	18	17	16
–	–	–	–	–	–	–	–
15	14	13	12	11	10	9	8
–	–	–	–	–	UNRE	TXEMPTY	–
7	6	5	4	3	2	1	0
–	–	OVRE	–	–	–	TXRDY	RXRDY

This configuration is relevant only if USART_MODE=0xE or 0xF in “[USART Mode Register](#)” on page 774.

- **RXRDY:** RXRDY Interrupt Enable
- **TXRDY:** TXRDY Interrupt Enable
- **OVRE:** Overrun Error Interrupt Enable
- **TXEMPTY:** TXEMPTY Interrupt Enable
- **UNRE:** SPI Underrun Error Interrupt Enable

0: No effect

1: Enables the corresponding interrupt.

34.8.7 USART Interrupt Disable Register

Name: US_IDR

Address: 0x4002400C (0), 0x4002800C (1)

Access: Write-only

31	30	29	28	27	26	25	24
–	–	–	–	–	–	–	MANE
23	22	21	20	19	18	17	16
–	–	–	–	CTSIC	DCDIC	DSRIC	RIIC
15	14	13	12	11	10	9	8
–	–	NACK	RXBUFF	TXBUFE	ITER	TXEMPTY	TIMEOUT
7	6	5	4	3	2	1	0
PARE	FRAME	OVRE	ENDTX	ENDRX	RXBRK	TXRDY	RXRDY

For SPI specific configuration, see [“USART Interrupt Disable Register \(SPI_MODE\)”](#) on page 785.

- **RXRDY:** RXRDY Interrupt Disable
- **TXRDY:** TXRDY Interrupt Disable
- **RXBRK:** Receiver Break Interrupt Disable
- **ENDRX:** End of Receive Transfer Interrupt Disable (available in all USART modes of operation)
- **ENDTX:** End of Transmit Interrupt Disable (available in all USART modes of operation)
- **OVRE:** Overrun Error Interrupt Enable
- **FRAME:** Framing Error Interrupt Disable
- **PARE:** Parity Error Interrupt Disable
- **TIMEOUT:** Time-out Interrupt Disable
- **TXEMPTY:** TXEMPTY Interrupt Disable
- **ITER:** Max number of Repetitions Reached Interrupt Disable
- **TXBUFE:** Buffer Empty Interrupt Disable (available in all USART modes of operation)
- **RXBUFF:** Buffer Full Interrupt Disable (available in all USART modes of operation)
- **NACK:** Non Acknowledge Interrupt Disable
- **RIIC:** Ring Indicator Input Change Disable
- **DSRIC:** Data Set Ready Input Change Disable
- **DCDIC:** Data Carrier Detect Input Change Interrupt Disable

- **CTSIC: Clear to Send Input Change Interrupt Disable**

- **MANE: Manchester Error Interrupt Disable**

0: No effect

1: Disables the corresponding interrupt.

34.8.8 USART Interrupt Disable Register (SPI_MODE)

Name: US_IDR (SPI_MODE)

Address: 0x4002400C (0), 0x4002800C (1)

Access: Write-only

31	30	29	28	27	26	25	24
–	–	–	–	–	–	–	–
23	22	21	20	19	18	17	16
–	–	–	–	–	–	–	–
15	14	13	12	11	10	9	8
–	–	–	–	–	UNRE	TXEMPTY	–
7	6	5	4	3	2	1	0
–	–	OVRE	–	–	–	TXRDY	RXRDY

This configuration is relevant only if USART_MODE=0xE or 0xF in [“USART Mode Register” on page 774](#).

- **RXRDY:** RXRDY Interrupt Disable
- **TXRDY:** TXRDY Interrupt Disable
- **OVRE:** Overrun Error Interrupt Disable
- **TXEMPTY:** TXEMPTY Interrupt Disable
- **UNRE:** SPI Underrun Error Interrupt Disable

0: No effect

1: Disables the corresponding interrupt.



34.8.9 USART Interrupt Mask Register

Name: US_IMR

Address: 0x40024010 (0), 0x40028010 (1)

Access: Read-only

31	30	29	28	27	26	25	24
–	–	–	–	–	–	–	MANE
23	22	21	20	19	18	17	16
–	–	–	–	CTSIC	DCDIC	DSRIC	RIIC
15	14	13	12	11	10	9	8
–	–	NACK	RXBUFF	TXBUFE	ITER	TXEMPTY	TIMEOUT
7	6	5	4	3	2	1	0
PARE	FRAME	OVRE	ENDTX	ENDRX	RXBRK	TXRDY	RXRDY

For SPI specific configuration, see [“USART Interrupt Mask Register \(SPI_MODE\)” on page 788](#).

- **RXRDY: RXRDY Interrupt Mask**
- **TXRDY: TXRDY Interrupt Mask**
- **RXBRK: Receiver Break Interrupt Mask**
- **ENDRX: End of Receive Transfer Interrupt Mask (available in all USART modes of operation)**
- **ENDTX: End of Transmit Interrupt Mask (available in all USART modes of operation)**
- **OVRE: Overrun Error Interrupt Mask**
- **FRAME: Framing Error Interrupt Mask**
- **PARE: Parity Error Interrupt Mask**
- **TIMEOUT: Time-out Interrupt Mask**
- **TXEMPTY: TXEMPTY Interrupt Mask**
- **ITER: Max number of Repetitions Reached Interrupt Mask**
- **TXBUFE: Buffer Empty Interrupt Mask (available in all USART modes of operation)**
- **RXBUFF: Buffer Full Interrupt Mask (available in all USART modes of operation)**
- **NACK: Non Acknowledge Interrupt Mask**
- **RIIC: Ring Indicator Input Change Mask**
- **DSRIC: Data Set Ready Input Change Mask**
- **DCDIC: Data Carrier Detect Input Change Interrupt Mask**

- **CTSIC: Clear to Send Input Change Interrupt Mask**

- **MANE: Manchester Error Interrupt Mask**

0: The corresponding interrupt is not enabled.

1: The corresponding interrupt is enabled.

34.8.10 USART Interrupt Mask Register (SPI_MODE)

Name: US_IMR (SPI_MODE)

Address: 0x40024010 (0), 0x40028010 (1)

Access: Read-only

31	30	29	28	27	26	25	24
–	–	–	–	–	–	–	–
23	22	21	20	19	18	17	16
–	–	–	–	–	–	–	–
15	14	13	12	11	10	9	8
–	–	–	–	–	UNRE	TXEMPTY	–
7	6	5	4	3	2	1	0
–	–	OVRE	–	–	–	TXRDY	RXRDY

This configuration is relevant only if USART_MODE=0xE or 0xF in [“USART Mode Register” on page 774](#).

- **RXRDY: RXRDY Interrupt Mask**
- **TXRDY: TXRDY Interrupt Mask**
- **OVRE: Overrun Error Interrupt Mask**
- **TXEMPTY: TXEMPTY Interrupt Mask**
- **UNRE: SPI Underrun Error Interrupt Mask**

0: The corresponding interrupt is not enabled.

1: The corresponding interrupt is enabled.

34.8.11 USART Channel Status Register

Name: US_CSR
Address: 0x40024014 (0), 0x40028014 (1)
Access: Read-only

31	30	29	28	27	26	25	24
–	–	–	–	–	–	–	MANERR
23	22	21	20	19	18	17	16
CTS	DCD	DSR	RI	CTSIC	DCDIC	DSRIC	RIIC
15	14	13	12	11	10	9	8
–	–	NACK	RXBUFF	TXBUFE	ITER	TXEMPTY	TIMEOUT
7	6	5	4	3	2	1	0
PARE	FRAME	OVRE	ENDTX	ENDRX	RXBRK	TXRDY	RXRDY

For SPI specific configuration, see [“USART Channel Status Register \(SPI_MODE\)” on page 792](#).

- **RXRDY: Receiver Ready**

0: No complete character has been received since the last read of US_RHR or the receiver is disabled. If characters were being received when the receiver was disabled, RXRDY changes to 1 when the receiver is enabled.

1: At least one complete character has been received and US_RHR has not yet been read.

- **TXRDY: Transmitter Ready**

0: A character is in the US_THR waiting to be transferred to the Transmit Shift Register, or an STTBRK command has been requested, or the transmitter is disabled. As soon as the transmitter is enabled, TXRDY becomes 1.

1: There is no character in the US_THR.

- **RXBRK: Break Received/End of Break**

0: No Break received or End of Break detected since the last RSTSTA.

1: Break Received or End of Break detected since the last RSTSTA.

- **ENDRX: End of Receiver Transfer**

0: The End of Transfer signal from the Receive PDC channel is inactive.

1: The End of Transfer signal from the Receive PDC channel is active.

- **ENDTX: End of Transmitter Transfer**

0: The End of Transfer signal from the Transmit PDC channel is inactive.

1: The End of Transfer signal from the Transmit PDC channel is active.

- **OVRE: Overrun Error**

0: No overrun error has occurred since the last RSTSTA.

1: At least one overrun error has occurred since the last RSTSTA.



- **FRAME: Framing Error**

- 0: No stop bit has been detected low since the last RSTSTA.
- 1: At least one stop bit has been detected low since the last RSTSTA.

- **PARE: Parity Error**

- 0: No parity error has been detected since the last RSTSTA.
- 1: At least one parity error has been detected since the last RSTSTA.

- **TIMEOUT: Receiver Time-out**

- 0: There has not been a time-out since the last Start Time-out command (STTTO in US_CR) or the Time-out Register is 0.
- 1: There has been a time-out since the last Start Time-out command (STTTO in US_CR).

- **TXEMPTY: Transmitter Empty**

- 0: There are characters in either US_THR or the Transmit Shift Register, or the transmitter is disabled.
- 1: There are no characters in US_THR, nor in the Transmit Shift Register.

- **ITER: Max number of Repetitions Reached**

- 0: Maximum number of repetitions has not been reached since the last RSTSTA.
- 1: Maximum number of repetitions has been reached since the last RSTSTA.

- **TXBUFE: Transmission Buffer Empty**

- 0: The signal Buffer Empty from the Transmit PDC channel is inactive.
- 1: The signal Buffer Empty from the Transmit PDC channel is active.

- **RXBUFF: Reception Buffer Full**

- 0: The signal Buffer Full from the Receive PDC channel is inactive.
- 1: The signal Buffer Full from the Receive PDC channel is active.

- **NACK: Non Acknowledge Interrupt**

- 0: Non Acknowledge has not been detected since the last RSTNACK.
- 1: At least one Non Acknowledge has been detected since the last RSTNACK.

- **RIIC: Ring Indicator Input Change Flag**

- 0: No input change has been detected on the RI pin since the last read of US_CSR.
- 1: At least one input change has been detected on the RI pin since the last read of US_CSR.

- **DSRIC: Data Set Ready Input Change Flag**

- 0: No input change has been detected on the DSR pin since the last read of US_CSR.
- 1: At least one input change has been detected on the DSR pin since the last read of US_CSR.

- **DCDIC: Data Carrier Detect Input Change Flag**

- 0: No input change has been detected on the DCD pin since the last read of US_CSR.
- 1: At least one input change has been detected on the DCD pin since the last read of US_CSR.

- **CTSIC: Clear to Send Input Change Flag**

0: No input change has been detected on the CTS pin since the last read of US_CSR.

1: At least one input change has been detected on the CTS pin since the last read of US_CSR.

- **RI: Image of RI Input**

0: RI is set to 0.

1: RI is set to 1.

- **DSR: Image of DSR Input**

0: DSR is set to 0

1: DSR is set to 1.

- **DCD: Image of DCD Input**

0: DCD is set to 0.

1: DCD is set to 1.

- **CTS: Image of CTS Input**

0: CTS is set to 0.

1: CTS is set to 1.

- **MANERR: Manchester Error**

0: No Manchester error has been detected since the last RSTSTA.

1: At least one Manchester error has been detected since the last RSTSTA.

34.8.12 USART Channel Status Register (SPI_MODE)

Name: US_CSR (SPI_MODE)
Address: 0x40024014 (0), 0x40028014 (1)
Access: Read-only

31	30	29	28	27	26	25	24
–	–	–	–	–	–	–	–
23	22	21	20	19	18	17	16
–	–	–	–	–	–	–	–
15	14	13	12	11	10	9	8
–	–	–	–	–	UNRE	TXEMPTY	–
7	6	5	4	3	2	1	0
–	–	OVRE	–	–	–	TXRDY	RXRDY

This configuration is relevant only if USART_MODE=0xE or 0xF in “USART Mode Register” on page 774.

- **RXRDY: Receiver Ready**

0: No complete character has been received since the last read of US_RHR or the receiver is disabled. If characters were being received when the receiver was disabled, RXRDY changes to 1 when the receiver is enabled.

1: At least one complete character has been received and US_RHR has not yet been read.

- **TXRDY: Transmitter Ready**

0: A character is in the US_THR waiting to be transferred to the Transmit Shift Register or the transmitter is disabled. As soon as the transmitter is enabled, TXRDY becomes 1.

1: There is no character in the US_THR.

- **OVRE: Overrun Error**

0: No overrun error has occurred since the last RSTSTA.

1: At least one overrun error has occurred since the last RSTSTA.

- **TXEMPTY: Transmitter Empty**

0: There are characters in either US_THR or the Transmit Shift Register, or the transmitter is disabled.

1: There are no characters in US_THR, nor in the Transmit Shift Register.

- **UNRE: Underrun Error**

0: No SPI underrun error has occurred since the last RSTSTA.

1: At least one SPI underrun error has occurred since the last RSTSTA.

34.8.13 USART Receive Holding Register

Name: US_RHR

Address: 0x40024018 (0), 0x40028018 (1)

Access: Read-only

31	30	29	28	27	26	25	24
–	–	–	–	–	–	–	–
23	22	21	20	19	18	17	16
–	–	–	–	–	–	–	–
15	14	13	12	11	10	9	8
RXSYNH	–	–	–	–	–	–	RXCHR
7	6	5	4	3	2	1	0
RXCHR							

- **RXCHR: Received Character**

Last character received if RXRDY is set.

- **RXSYNH: Received Sync**

0: Last Character received is a Data.

1: Last Character received is a Command.

34.8.14 USART Transmit Holding Register

Name: US_THR

Address: 0x4002401C (0), 0x4002801C (1)

Access: Write-only

31	30	29	28	27	26	25	24
–	–	–	–	–	–	–	–
23	22	21	20	19	18	17	16
–	–	–	–	–	–	–	–
15	14	13	12	11	10	9	8
TXSYNH	–	–	–	–	–	–	TXCHR
7	6	5	4	3	2	1	0
TXCHR							

- **TXCHR: Character to be Transmitted**

Next character to be transmitted after the current character if TXRDY is not set.

- **TXSYNH: Sync Field to be transmitted**

0: The next character sent is encoded as a data. Start Frame Delimiter is DATA SYNC.

1: The next character sent is encoded as a command. Start Frame Delimiter is COMMAND SYNC.

34.8.15 USART Baud Rate Generator Register

Name: US_BRGR
Address: 0x40024020 (0), 0x40028020 (1)
Access: Read-write

31	30	29	28	27	26	25	24
–	–	–	–	–	–	–	–
23	22	21	20	19	18	17	16
–	–	–	–	–	–	FP	–
15	14	13	12	11	10	9	8
CD							
7	6	5	4	3	2	1	0
CD							

This register can only be written if the WPEN bit is cleared in “USART Write Protect Mode Register” on page 803.

- **CD: Clock Divider**

CD	USART_MODE ≠ ISO7816			USART_MODE = ISO7816
	SYNC = 0		SYNC = 1 or USART_MODE = SPI (Master or Slave)	
	OVER = 0	OVER = 1		
0	Baud Rate Clock Disabled			
1 to 65535	Baud Rate = Selected Clock/(16*CD)	Baud Rate = Selected Clock/(8*CD)	Baud Rate = Selected Clock /CD	Baud Rate = Selected Clock/(FI_DI_RATIO*CD)

- **FP: Fractional Part**

0: Fractional divider is disabled.

1 - 7: Baudrate resolution, defined by FP x 1/8.



34.8.16 USART Receiver Time-out Register

Name: US_RTOR

Address: 0x40024024 (0), 0x40028024 (1)

Access: Read-write

31	30	29	28	27	26	25	24
–	–	–	–	–	–	–	–
23	22	21	20	19	18	17	16
–	–	–	–	–	–	–	–
15	14	13	12	11	10	9	8
TO							
7	6	5	4	3	2	1	0
TO							

This register can only be written if the WPEN bit is cleared in [“USART Write Protect Mode Register”](#) on page 803.

- **TO: Time-out Value**

0: The Receiver Time-out is disabled.

1 - 65535: The Receiver Time-out is enabled and the Time-out delay is TO x Bit Period.



34.8.17 USART Transmitter Timeguard Register

Name: US_TTGR
Address: 0x40024028 (0), 0x40028028 (1)
Access: Read-write

31	30	29	28	27	26	25	24
–	–	–	–	–	–	–	–
23	22	21	20	19	18	17	16
–	–	–	–	–	–	–	–
15	14	13	12	11	10	9	8
–	–	–	–	–	–	–	–
7	6	5	4	3	2	1	0
TG							

This register can only be written if the WPEN bit is cleared in [“USART Write Protect Mode Register” on page 803](#).

- **TG: Timeguard Value**

0: The Transmitter Timeguard is disabled.

1 - 255: The Transmitter timeguard is enabled and the timeguard delay is TG x Bit Period.



34.8.18 USART FI DI RATIO Register

Name: US_FIDI
Address: 0x40024040 (0), 0x40028040 (1)
Access: Read-write
Reset Value: 0x174

31	30	29	28	27	26	25	24
–	–	–	–	–	–	–	–
23	22	21	20	19	18	17	16
–	–	–	–	–	–	–	–
15	14	13	12	11	10	9	8
–	–	–	–	–	FI_DI_RATIO		
7	6	5	4	3	2	1	0
FI_DI_RATIO							

This register can only be written if the WPEN bit is cleared in [“USART Write Protect Mode Register” on page 803](#).

• **FI_DI_RATIO: FI Over DI Ratio Value**

0: If ISO7816 mode is selected, the Baud Rate Generator generates no signal.

1 - 2047: If ISO7816 mode is selected, the Baud Rate is the clock provided on SCK divided by FI_DI_RATIO.

34.8.19 USART Number of Errors Register

Name: US_NER

Address: 0x40024044 (0), 0x40028044 (1)

Access: Read-only

31	30	29	28	27	26	25	24
–	–	–	–	–	–	–	–
23	22	21	20	19	18	17	16
–	–	–	–	–	–	–	–
15	14	13	12	11	10	9	8
–	–	–	–	–	–	–	–
7	6	5	4	3	2	1	0
NB_ERRORS							

This register is relevant only if USART_MODE=0x4 or 0x6 in [“USART Mode Register” on page 774](#).

- **NB_ERRORS: Number of Errors**

Total number of errors that occurred during an ISO7816 transfer. This register automatically clears when read.

34.8.20 USART IrDA FILTER Register

Name: US_IF

Address: 0x4002404C (0), 0x4002804C (1)

Access: Read-write

31	30	29	28	27	26	25	24
–	–	–	–	–	–	–	–
23	22	21	20	19	18	17	16
–	–	–	–	–	–	–	–
15	14	13	12	11	10	9	8
–	–	–	–	–	–	–	–
7	6	5	4	3	2	1	0
IRDA_FILTER							

This register is relevant only if USART_MODE=0x8 in “[USART Mode Register](#)” on page 774.

This register can only be written if the WPEN bit is cleared in “[USART Write Protect Mode Register](#)” on page 803.

- **IRDA_FILTER: IrDA Filter**

Sets the filter of the IrDA demodulator.



34.8.21 USART Manchester Configuration Register

Name: US_MAN

Address: 0x40024050 (0), 0x40028050 (1)

Access: Read-write

31	30	29	28	27	26	25	24	
–	DRIFT	ONE	RX_MPOL	–	–	RX_PP		
23	22	21	20	19	18	17	16	
–	–	–	–	RX_PL				–
15	14	13	12	11	10	9	8	
–	–	–	TX_MPOL	–	–	TX_PP		
7	6	5	4	3	2	1	0	
–	–	–	–	TX_PL				–

This register can only be written if the WPEN bit is cleared in [“USART Write Protect Mode Register” on page 803](#).

• **TX_PL: Transmitter Preamble Length**

0: The Transmitter Preamble pattern generation is disabled

1 - 15: The Preamble Length is TX_PL x Bit Period

• **TX_PP: Transmitter Preamble Pattern**

The following values assume that TX_MPOL field is not set:

Value	Name	Description
00	ALL_ONE	The preamble is composed of '1's
01	ALL_ZERO	The preamble is composed of '0's
10	ZERO_ONE	The preamble is composed of '01's
11	ONE_ZERO	The preamble is composed of '10's

• **TX_MPOL: Transmitter Manchester Polarity**

0: Logic Zero is coded as a zero-to-one transition, Logic One is coded as a one-to-zero transition.

1: Logic Zero is coded as a one-to-zero transition, Logic One is coded as a zero-to-one transition.

• **RX_PL: Receiver Preamble Length**

0: The receiver preamble pattern detection is disabled

1 - 15: The detected preamble length is RX_PL x Bit Period

• **RX_PP: Receiver Preamble Pattern detected**

The following values assume that RX_MPOL field is not set:

Value	Name	Description
00	ALL_ONE	The preamble is composed of '1's

01	ALL_ZERO	The preamble is composed of '0's
10	ZERO_ONE	The preamble is composed of '01's
11	ONE_ZERO	The preamble is composed of '10's

- **RX_MPOL: Receiver Manchester Polarity**

0: Logic Zero is coded as a zero-to-one transition, Logic One is coded as a one-to-zero transition.

1: Logic Zero is coded as a one-to-zero transition, Logic One is coded as a zero-to-one transition.

- **ONE: Must Be Set to 1**

Bit 29 must always be set to 1 when programming the US_MAN register.

- **DRIFT: Drift compensation**

0: The USART can not recover from an important clock drift

1: The USART can recover from clock drift. The 16X clock mode must be enabled.

34.8.22 USART Write Protect Mode Register

Name: US_WPMR
Address: 0x400240E4 (0), 0x400280E4 (1)
Access: Read-write
Reset: See [Table 34-16](#)

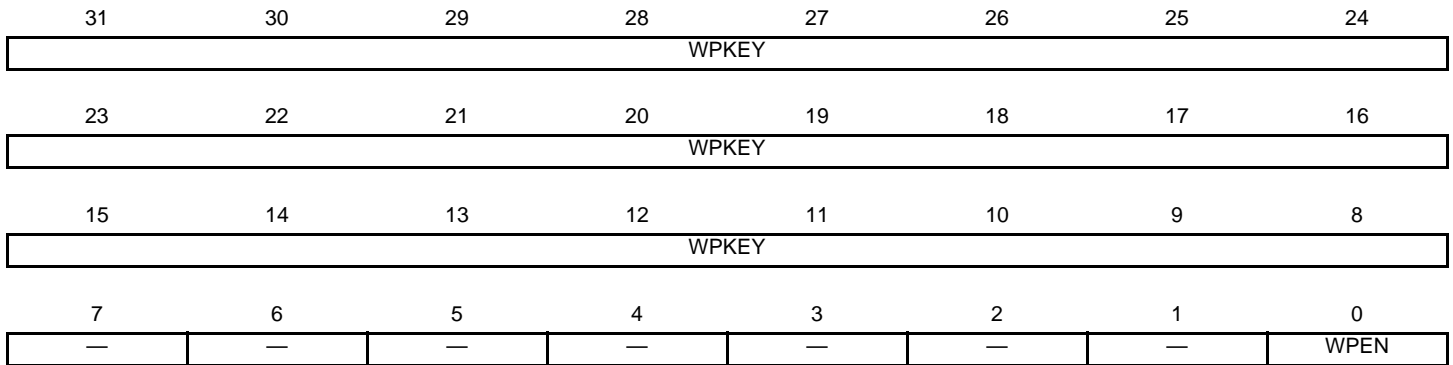

- **WPEN: Write Protect Enable**

0 = Disables the Write Protect if WPKEY corresponds to 0x555341 (“USA” in ASCII).

1 = Enables the Write Protect if WPKEY corresponds to 0x555341 (“USA” in ASCII).

Protects the registers:

- [“USART Mode Register” on page 774](#)
- [“USART Baud Rate Generator Register” on page 795](#)
- [“USART Receiver Time-out Register” on page 796](#)
- [“USART Transmitter Timeguard Register” on page 797](#)
- [“USART FI DI RATIO Register” on page 798](#)
- [“USART IrDA FILTER Register” on page 800](#)
- [“USART Manchester Configuration Register” on page 801](#)

- **WPKEY: Write Protect KEY**

Should be written at value 0x555341 (“USA” in ASCII). Writing any other value in this field aborts the write operation of the WPEN bit. Always reads as 0.

34.8.23 USART Write Protect Status Register

Name: US_WPSR
Address: 0x400240E8 (0), 0x400280E8 (1)
Access: Read-only
Reset: See [Table 34-16](#)

31	30	29	28	27	26	25	24
—	—	—	—	—	—	—	—
23	22	21	20	19	18	17	16
WPVSR							
15	14	13	12	11	10	9	8
WPVSR							
7	6	5	4	3	2	1	0
—	—	—	—	—	—	—	WPVS

- **WPVS: Write Protect Violation Status**

0 = No Write Protect Violation has occurred since the last read of the US_WPSR register.

1 = A Write Protect Violation has occurred since the last read of the US_WPSR register. If this violation is an unauthorized attempt to write a protected register, the associated violation is reported into field WPVSR.

- **WPVSR: Write Protect Violation Source**

When WPVS is active, this field indicates the write-protected register (through address offset or code) in which a write access has been attempted.

Note: Reading US_WPSR automatically clears all fields.

35. Timer Counter (TC)

35.1 Description

The Timer Counter (TC) includes 3 identical 16-bit Timer Counter channels.

Each channel can be independently programmed to perform a wide range of functions including frequency measurement, event counting, interval measurement, pulse generation, delay timing and pulse width modulation.

Each channel has three external clock inputs, five internal clock inputs and two multi-purpose input/output signals which can be configured by the user. Each channel drives an internal interrupt signal which can be programmed to generate processor interrupts.

The Timer Counter (TC) embeds a quadrature decoder logic connected in front of the timers and driven by TIOA0, TIOB0 and TIOA1 inputs. When enabled, the quadrature decoder performs the input lines filtering, decoding of quadrature signals and connects to the timers/counters in order to read the position and speed of the motor through the user interface.

The Timer Counter block has two global registers which act upon all TC channels.

The Block Control Register allows the channels to be started simultaneously with the same instruction.

The Block Mode Register defines the external clock inputs for each channel, allowing them to be chained.

[Table 35-1](#) gives the assignment of the device Timer Counter clock inputs common to Timer Counter 0 to 2.

Table 35-1. Timer Counter Clock Assignment

Name	Definition
TIMER_CLOCK1	MCK/2
TIMER_CLOCK2	MCK/8
TIMER_CLOCK3	MCK/32
TIMER_CLOCK4	MCK/128
TIMER_CLOCK5 ⁽¹⁾	SLCK

Note: 1. When Slow Clock is selected for Master Clock (CSS = 0 in PMC Master Clock Register), TIMER_CLOCK5 input is equivalent to Master Clock.

35.2 Embedded Characteristics

- Six 16-bit Timer Counter Channels
- Wide range of functions including:
 - Frequency Measurement
 - Event Counting
 - Interval Measurement
 - Pulse Generation
 - Delay Timing
 - Pulse Width Modulation
 - Up/down Capabilities

- Each channel is user-configurable and contains:
 - Three external clock inputs
 - Five internal clock inputs
 - Two multi-purpose input/output signals
- Two global registers that act on all three TC Channels
- Quadrature decoder
 - Advanced line filtering
 - Position / revolution / speed
- 2-bit Gray Up/Down Counter for Stepper Motor

35.3 Block Diagram

Figure 35-1. Timer Counter Block Diagram

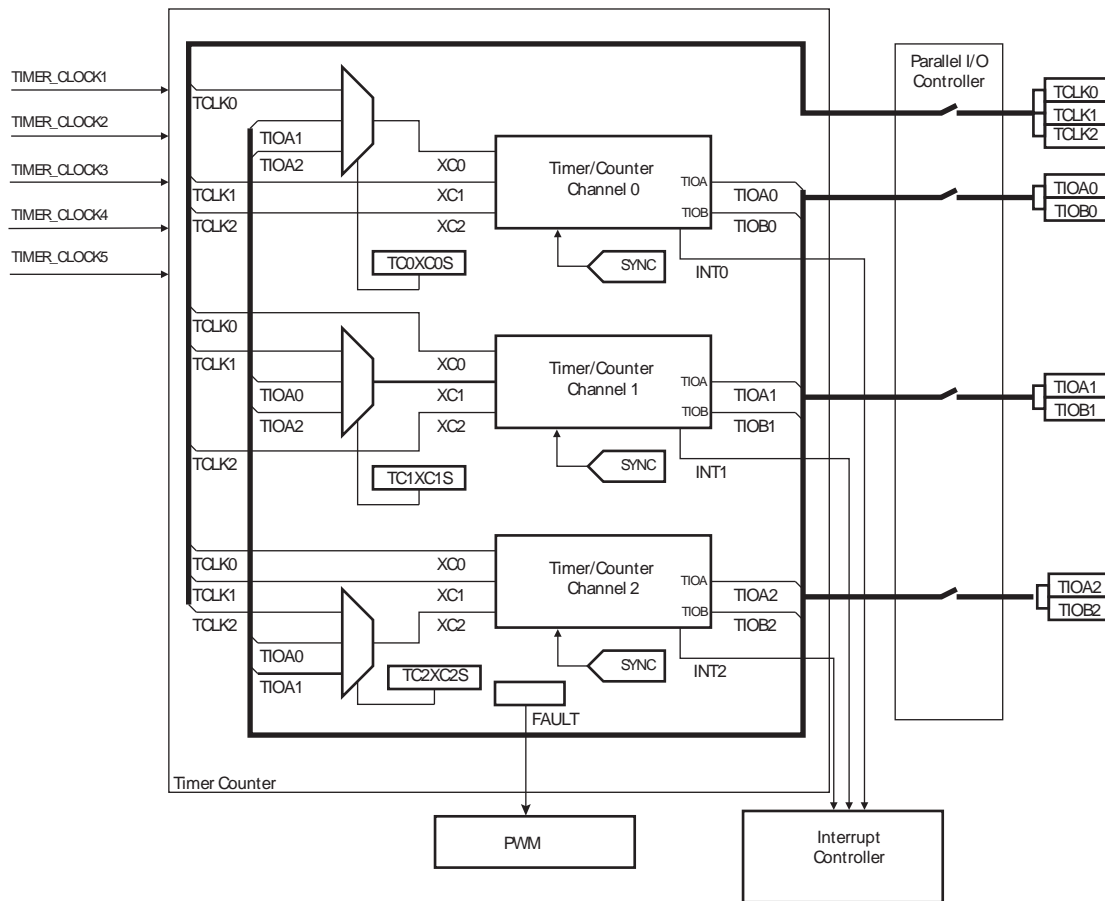

Note: The quadrature decoder logic connections are detailed in [Figure 35-15 "Predefined Connection of the Quadrature Decoder with Timer Counters"](#)

Table 35-2. Signal Name Description

Block/Channel	Signal Name	Description
Channel Signal	XC0, XC1, XC2	External Clock Inputs
	TIOA	Capture Mode: Timer Counter Input Waveform Mode: Timer Counter Output
	TIOB	Capture Mode: Timer Counter Input Waveform Mode: Timer Counter Input/Output
	INT	Interrupt Signal Output (internal signal)
	SYNC	Synchronization Input Signal (from configuration register)

35.4 Pin Name List

Table 35-3. TC pin list

Pin Name	Description	Type
TCLK0-TCLK2	External Clock Input	Input
TIOA0-TIOA2	I/O Line A	I/O
TIOB0-TIOB2	I/O Line B	I/O

35.5 Product Dependencies

35.5.1 I/O Lines

The pins used for interfacing the compliant external devices may be multiplexed with PIO lines. The programmer must first program the PIO controllers to assign the TC pins to their peripheral functions.

Table 35-4. I/O Lines

Instance	Signal	I/O Line	Peripheral
TC0	TCLK0	PA4	B
TC0	TCLK1	PA28	B
TC0	TCLK2	PA29	B
TC0	TIOA0	PA0	B
TC0	TIOA1	PA15	B
TC0	TIOA2	PA26	B
TC0	TIOB0	PA1	B
TC0	TIOB1	PA16	B
TC0	TIOB2	PA27	B
TC1	TCLK3	PC25	B
TC1	TCLK4	PC28	B
TC1	TCLK5	PC31	B
TC1	TIOA3	PC23	B

Table 35-4. I/O Lines

TC1	TIOA4	PC26	B
TC1	TIOA5	PC29	B
TC1	TIOB3	PC24	B
TC1	TIOB4	PC27	B
TC1	TIOB5	PC30	B

35.5.2 Power Management

The TC is clocked through the Power Management Controller (PMC), thus the programmer must first configure the PMC to enable the Timer Counter clock.

35.5.3 Interrupt

The TC has an interrupt line connected to the Interrupt Controller (IC). Handling the TC interrupt requires programming the IC before configuring the TC.

35.5.4 Fault Output

The TC has the FAULT output internally connected to the fault input of PWM. Refer to [Section 35.6.17 "Fault Mode"](#), and to the product Pulse Width Modulation (PWM) implementation.

35.6 Functional Description

35.6.1 TC Description

The 3 channels of the Timer Counter are independent and identical in operation except when quadrature decoder is enabled. The registers for channel programming are listed in [Table 35-5 on page 832](#).

35.6.2 16-bit Counter

Each channel is organized around a 16-bit counter. The value of the counter is incremented at each positive edge of the selected clock. When the counter has reached the value 0xFFFF and passes to 0x0000, an overflow occurs and the COVFS bit in TC_SR (Status Register) is set.

The current value of the counter is accessible in real time by reading the Counter Value Register, TC_CV. The counter can be reset by a trigger. In this case, the counter value passes to 0x0000 on the next valid edge of the selected clock.

35.6.3 Clock Selection

At block level, input clock signals of each channel can either be connected to the external inputs TCLK0, TCLK1 or TCLK2, or be connected to the internal I/O signals TIOA0, TIOA1 or TIOA2 for chaining by programming the TC_BMR (Block Mode). See [Figure 35-2 "Clock Chaining Selection"](#).

Each channel can independently select an internal or external clock source for its counter:

- Internal clock signals: TIMER_CLOCK1, TIMER_CLOCK2, TIMER_CLOCK3, TIMER_CLOCK4, TIMER_CLOCK5
- External clock signals: XC0, XC1 or XC2

This selection is made by the TCCLKS bits in the TC Channel Mode Register.

The selected clock can be inverted with the CLKI bit in TC_CMR. This allows counting on the opposite edges of the clock.

The burst function allows the clock to be validated when an external signal is high. The BURST parameter in the Mode Register defines this signal (none, XC0, XC1, XC2). See [Figure 35-3 "Clock Selection"](#)

Note: In all cases, if an external clock is used, the duration of each of its levels must be longer than the master clock period. The external clock frequency must be at least 2.5 times lower than the master clock

Figure 35-2. Clock Chaining Selection

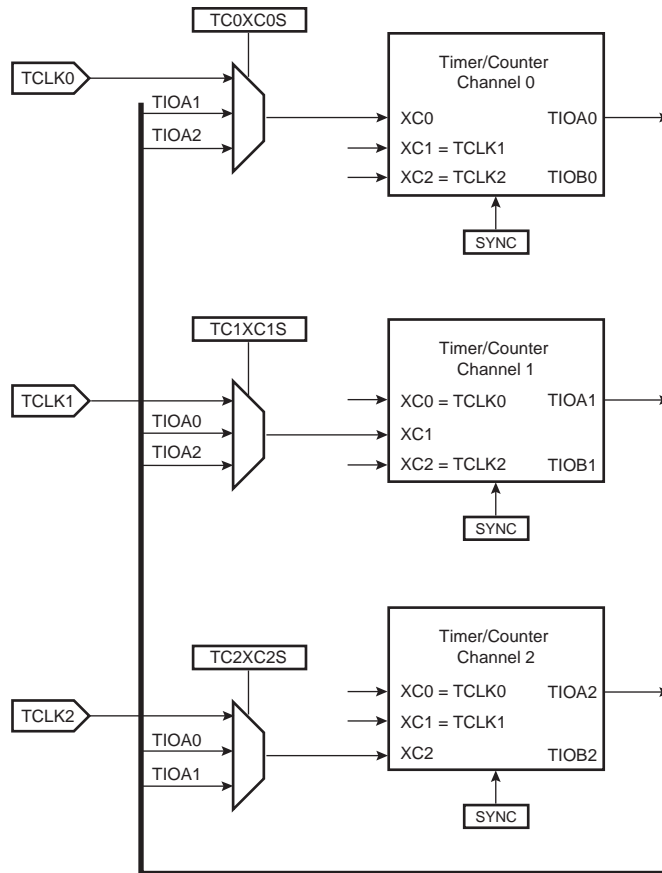
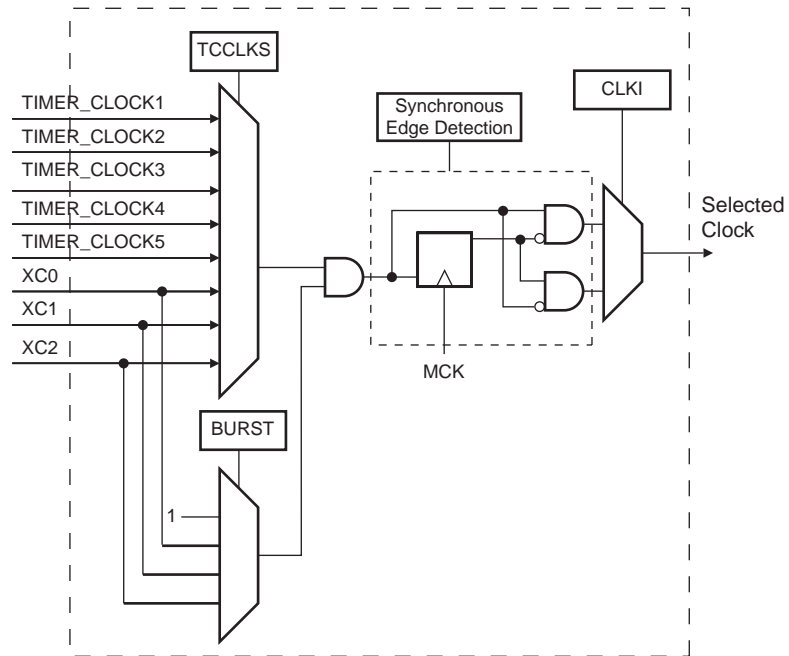

Figure 35-3. Clock Selection



35.6.4 Clock Control

The clock of each counter can be controlled in two different ways: it can be enabled/disabled and started/stopped. See [Figure 35-4](#).

- The clock can be enabled or disabled by the user with the CLKEN and the CLKDIS commands in the Control Register. In Capture Mode it can be disabled by an RB load event if LDBDIS is set to 1 in TC_CMR. In Waveform Mode, it can be disabled by an RC Compare event if CPCDIS is set to 1 in TC_CMR. When disabled, the start or the stop actions have no effect: only a CLKEN command in the Control Register can re-enable the clock. When the clock is enabled, the CLKSTA bit is set in the Status Register.
- The clock can also be started or stopped: a trigger (software, synchro, external or compare) always starts the clock. The clock can be stopped by an RB load event in Capture Mode (LDBSTOP = 1 in TC_CMR) or a RC compare event in Waveform Mode (CPCSTOP = 1 in TC_CMR). The start and the stop commands have effect only if the clock is enabled.

Figure 35-4. Clock Control

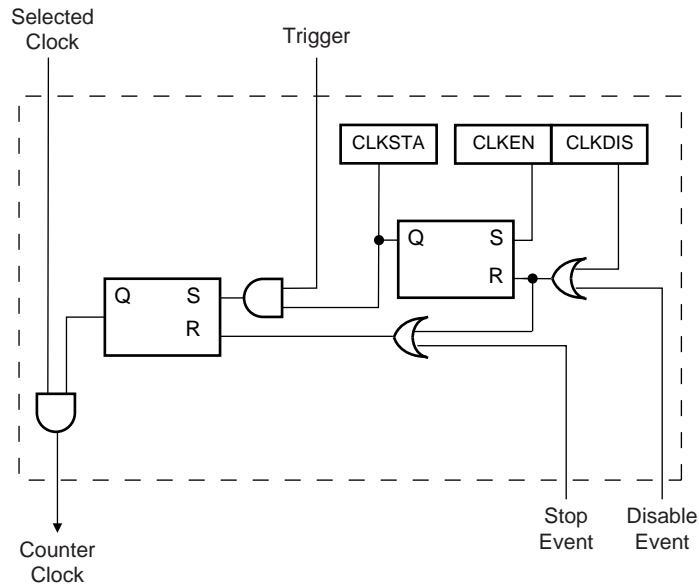

35.6.5 TC Operating Modes

Each channel can independently operate in two different modes:

- Capture Mode provides measurement on signals.
- Waveform Mode provides wave generation.

The TC Operating Mode is programmed with the WAVE bit in the TC Channel Mode Register.

In Capture Mode, TIOA and TIOB are configured as inputs.

In Waveform Mode, TIOA is always configured to be an output and TIOB is an output if it is not selected to be the external trigger.

35.6.6 Trigger

A trigger resets the counter and starts the counter clock. Three types of triggers are common to both modes, and a fourth external trigger is available to each mode.

Regardless of the trigger used, it will be taken into account at the following active edge of the selected clock. This means that the counter value can be read differently from zero just after a trigger, especially when a low frequency signal is selected as the clock.

The following triggers are common to both modes:

- Software Trigger: Each channel has a software trigger, available by setting SWTRG in TC_CCR.
- SYNC: Each channel has a synchronization signal SYNC. When asserted, this signal has the same effect as a software trigger. The SYNC signals of all channels are asserted simultaneously by writing TC_BCR (Block Control) with SYNC set.
- Compare RC Trigger: RC is implemented in each channel and can provide a trigger when the counter value matches the RC value if CPCTRG is set in TC_CMR.

The channel can also be configured to have an external trigger. In Capture Mode, the external trigger signal can be selected between TIOA and TIOB. In Waveform Mode, an external event can be programmed on one of the following signals: TIOB, XC0, XC1 or XC2. This external event can then be programmed to perform a trigger by setting ENETRIG in TC_CMR.

If an external trigger is used, the duration of the pulses must be longer than the master clock period in order to be detected.

35.6.7 Capture Operating Mode

This mode is entered by clearing the WAVE parameter in TC_CMR (Channel Mode Register).

Capture Mode allows the TC channel to perform measurements such as pulse timing, frequency, period, duty cycle and phase on TIOA and TIOB signals which are considered as inputs.

[Figure 35-5](#) shows the configuration of the TC channel when programmed in Capture Mode.

35.6.8 Capture Registers A and B

Registers A and B (RA and RB) are used as capture registers. This means that they can be loaded with the counter value when a programmable event occurs on the signal TIOA.

The LDRA parameter in TC_CMR defines the TIOA selected edge for the loading of register A, and the LDRB parameter defines the TIOA selected edge for the loading of Register B.

RA is loaded only if it has not been loaded since the last trigger or if RB has been loaded since the last loading of RA.

RB is loaded only if RA has been loaded since the last trigger or the last loading of RB.

Loading RA or RB before the read of the last value loaded sets the Overrun Error Flag (LOVRS) in TC_SR (Status Register). In this case, the old value is overwritten.

35.6.9 Trigger Conditions

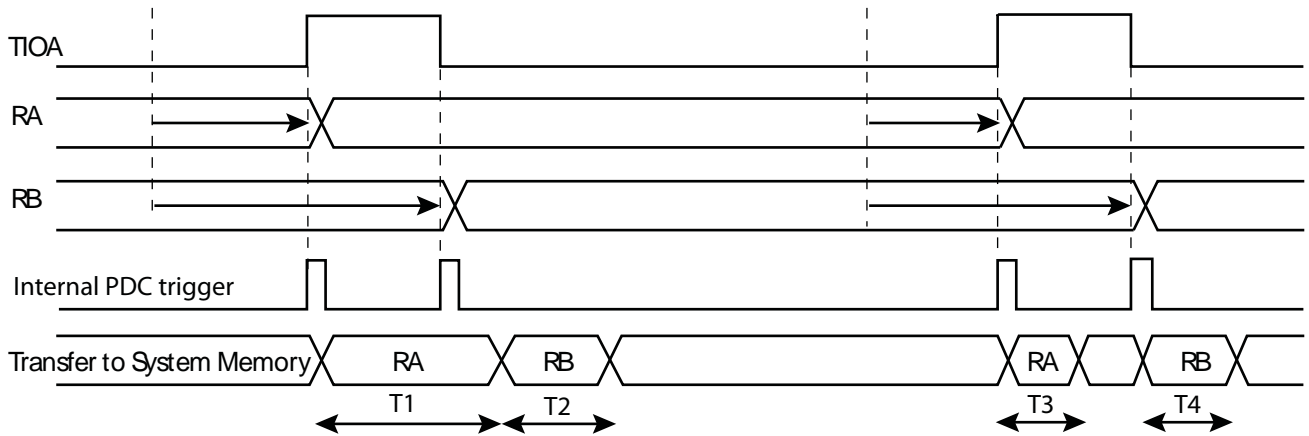

T1,T2,T3,T4 = System Bus load dependent (Tmin = 8 MCK)

ETRGEDG=3, LDRA=3, LDRB=0, ABETRG=0

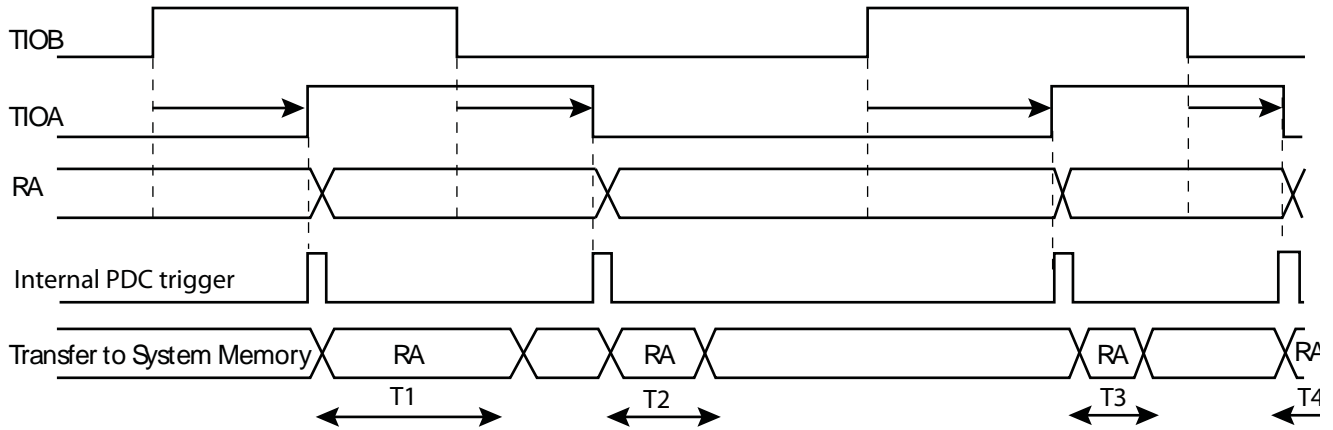

T1,T2,T3,T4 = System Bus load dependent (Tmin = 8 MCK)

In addition to the SYNC signal, the software trigger and the RC compare trigger, an external trigger can be defined.

The ABETRG bit in the TC_CMRR register selects TIOA or TIOB input signal as an external trigger. The ETRGEDG parameter defines the edge (rising, falling or both) detected to generate an external trigger. If ETRGEDG = 0 (none), the external trigger is disabled.

Figure 35-5. Capture Mode

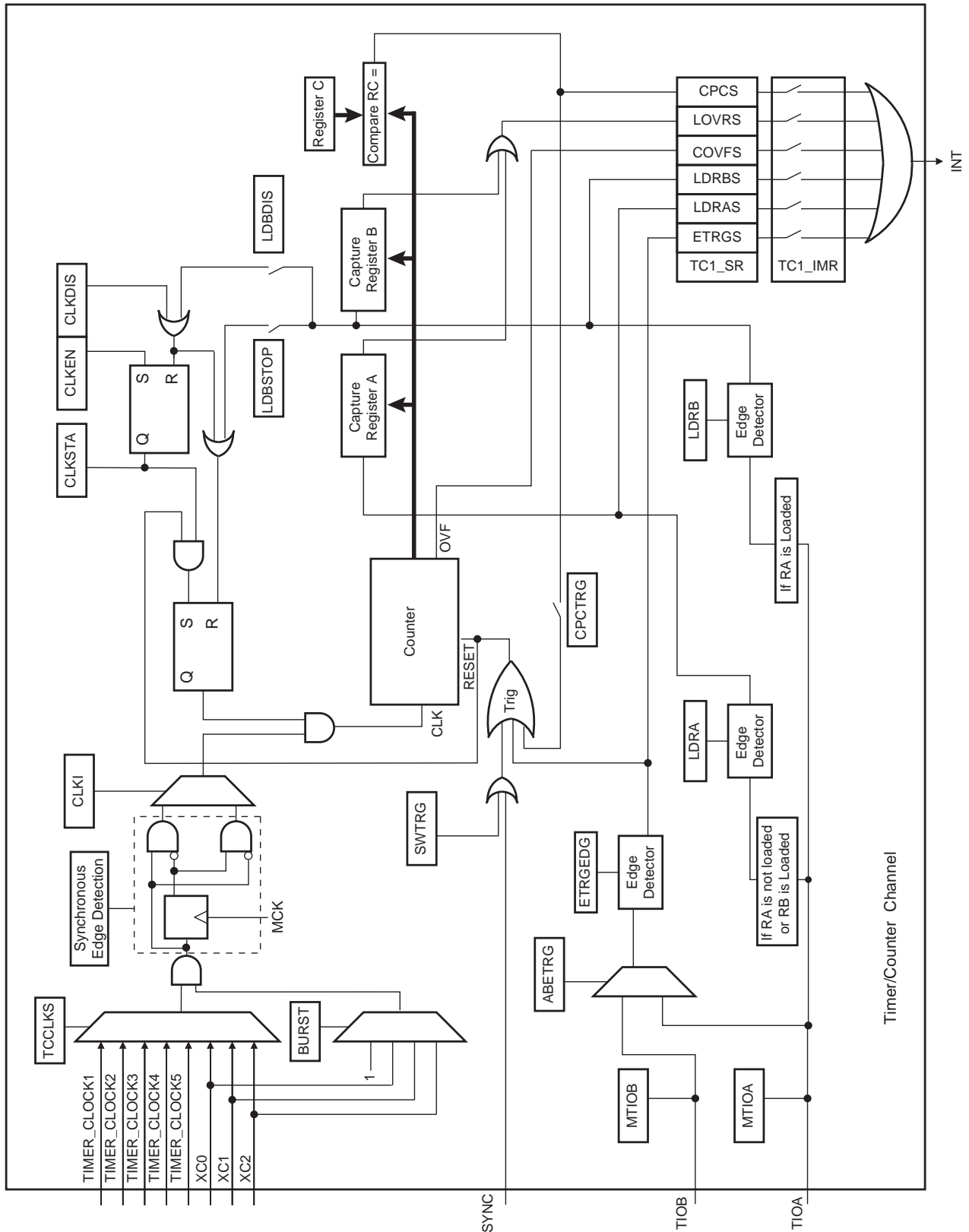

35.6.10 Waveform Operating Mode

Waveform operating mode is entered by setting the WAVE parameter in TC_CMR (Channel Mode Register).

In Waveform Operating Mode the TC channel generates 1 or 2 PWM signals with the same frequency and independently programmable duty cycles, or generates different types of one-shot or repetitive pulses.

In this mode, TIOA is configured as an output and TIOB is defined as an output if it is not used as an external event (EEVT parameter in TC_CMR).

Figure 35-6 shows the configuration of the TC channel when programmed in Waveform Operating Mode.

35.6.11 Waveform Selection

Depending on the WAVSEL parameter in TC_CMR (Channel Mode Register), the behavior of TC_CV varies.

With any selection, RA, RB and RC can all be used as compare registers.

RA Compare is used to control the TIOA output, RB Compare is used to control the TIOB output (if correctly configured) and RC Compare is used to control TIOA and/or TIOB outputs.

Figure 35-6. Waveform Mode

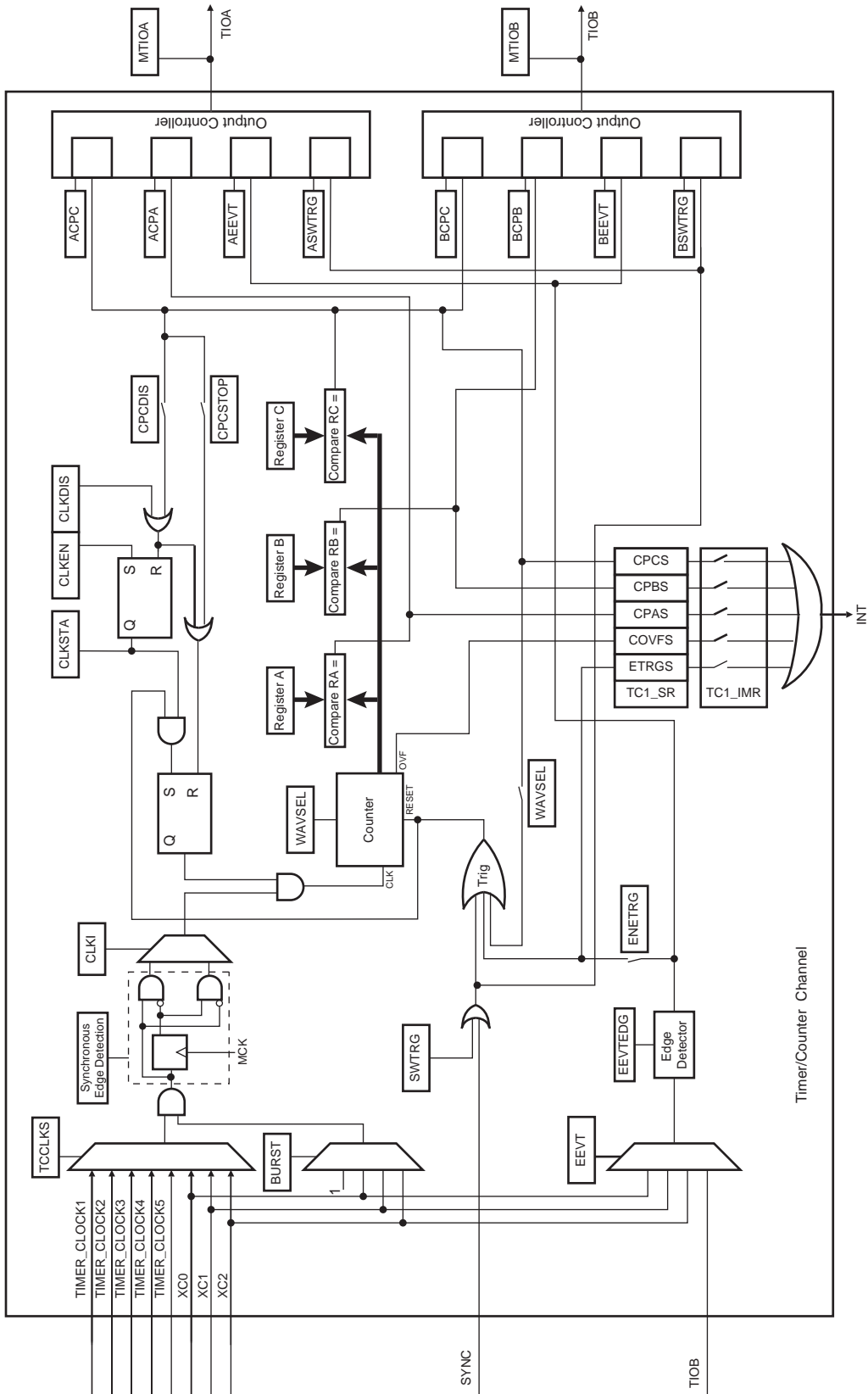

35.6.11.1 WAVSEL = 00

When WAVSEL = 00, the value of TC_CV is incremented from 0 to 0xFFFF. Once 0xFFFF has been reached, the value of TC_CV is reset. Incrementation of TC_CV starts again and the cycle continues. See [Figure 35-7](#).

An external event trigger or a software trigger can reset the value of TC_CV. It is important to note that the trigger may occur at any time. See [Figure 35-8](#).

RC Compare cannot be programmed to generate a trigger in this configuration. At the same time, RC Compare can stop the counter clock (CPCSTOP = 1 in TC_CMR) and/or disable the counter clock (CPCDIS = 1 in TC_CMR).

Figure 35-7. WAVSEL= 00 without trigger

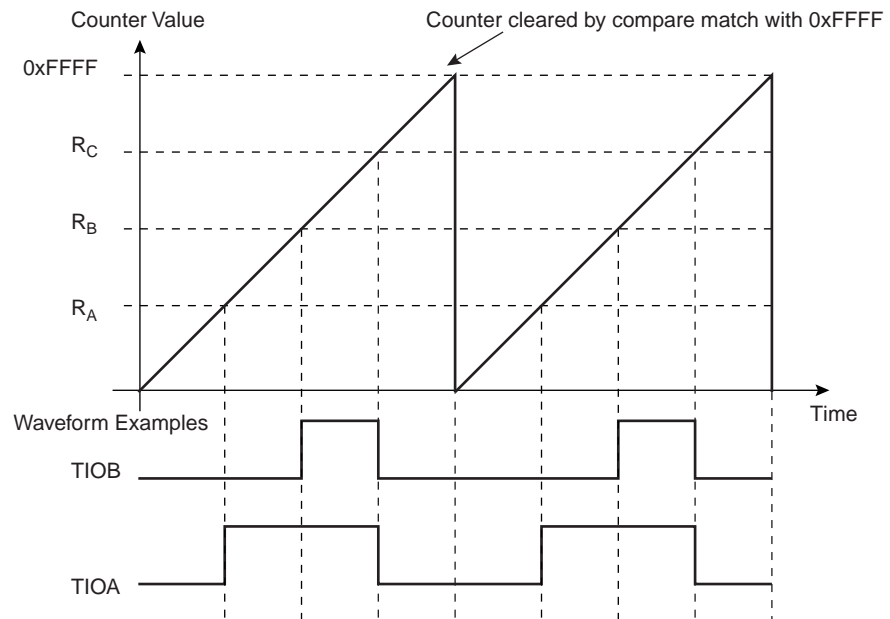
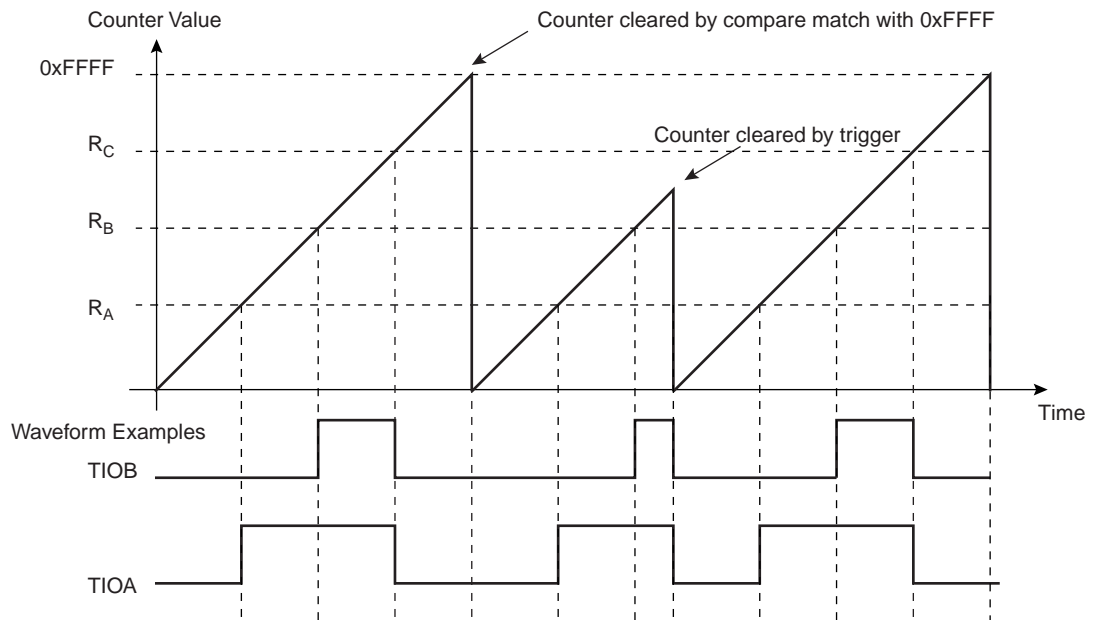

Figure 35-8. WAVSEL= 00 with trigger



35.6.11.2 WAVSEL = 10

When WAVSEL = 10, the value of TC_CV is incremented from 0 to the value of RC, then automatically reset on a RC Compare. Once the value of TC_CV has been reset, it is then incremented and so on. See [Figure 35-9](#).

It is important to note that TC_CV can be reset at any time by an external event or a software trigger if both are programmed correctly. See [Figure 35-10](#).

In addition, RC Compare can stop the counter clock (CPCSTOP = 1 in TC_CMR) and/or disable the counter clock (CPCDIS = 1 in TC_CMR).

Figure 35-9. WAVSEL = 10 Without Trigger

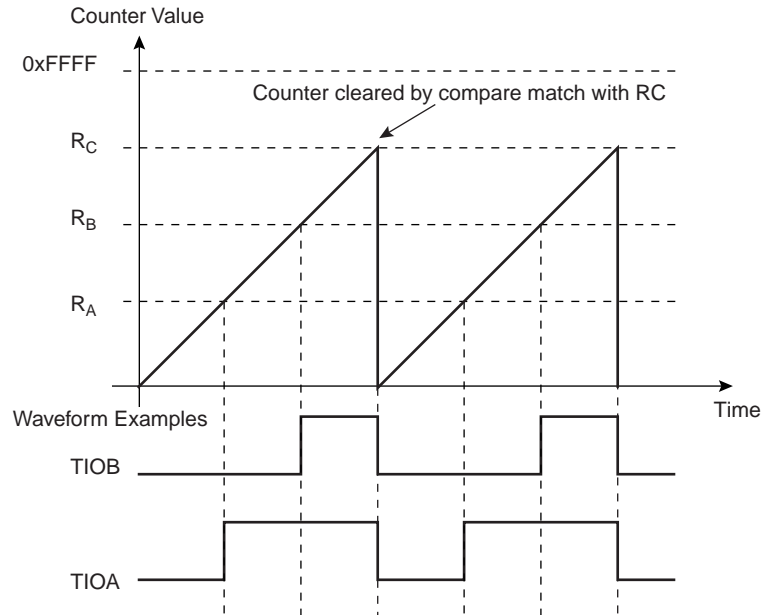
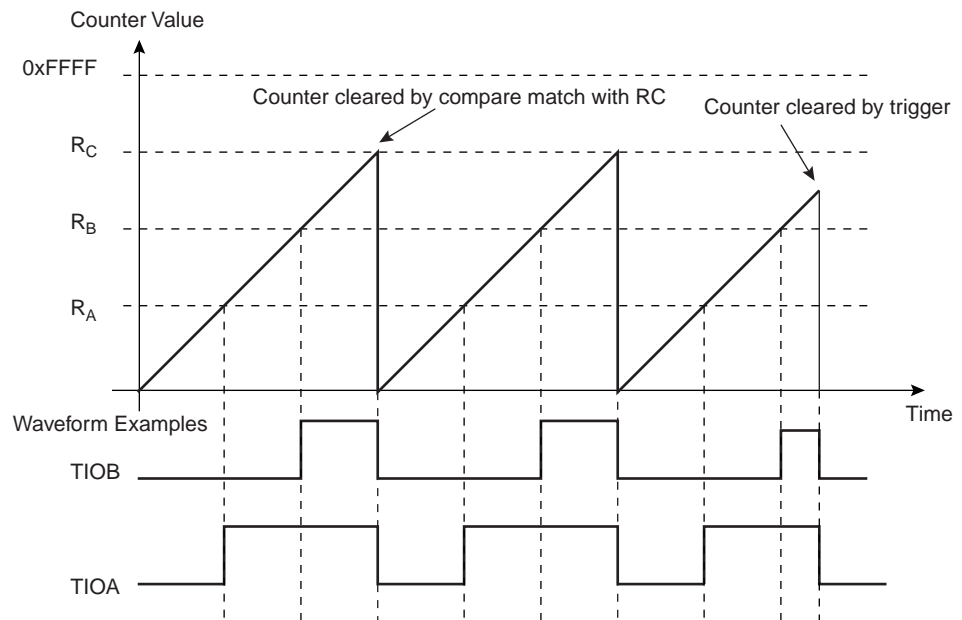

Figure 35-10. WAVSEL = 10 With Trigger



35.6.11.3 WAVSEL = 01

When WAVSEL = 01, the value of TC_CV is incremented from 0 to 0xFFFF. Once 0xFFFF is reached, the value of TC_CV is decremented to 0, then re-incremented to 0xFFFF and so on. See [Figure 35-11](#).

A trigger such as an external event or a software trigger can modify TC_CV at any time. If a trigger occurs while TC_CV is incrementing, TC_CV then decrements. If a trigger is received while TC_CV is decrementing, TC_CV then increments. See [Figure 35-12](#).

RC Compare cannot be programmed to generate a trigger in this configuration.

At the same time, RC Compare can stop the counter clock (CPCSTOP = 1) and/or disable the counter clock (CPCDIS = 1).

Figure 35-11. WAVSEL = 01 Without Trigger

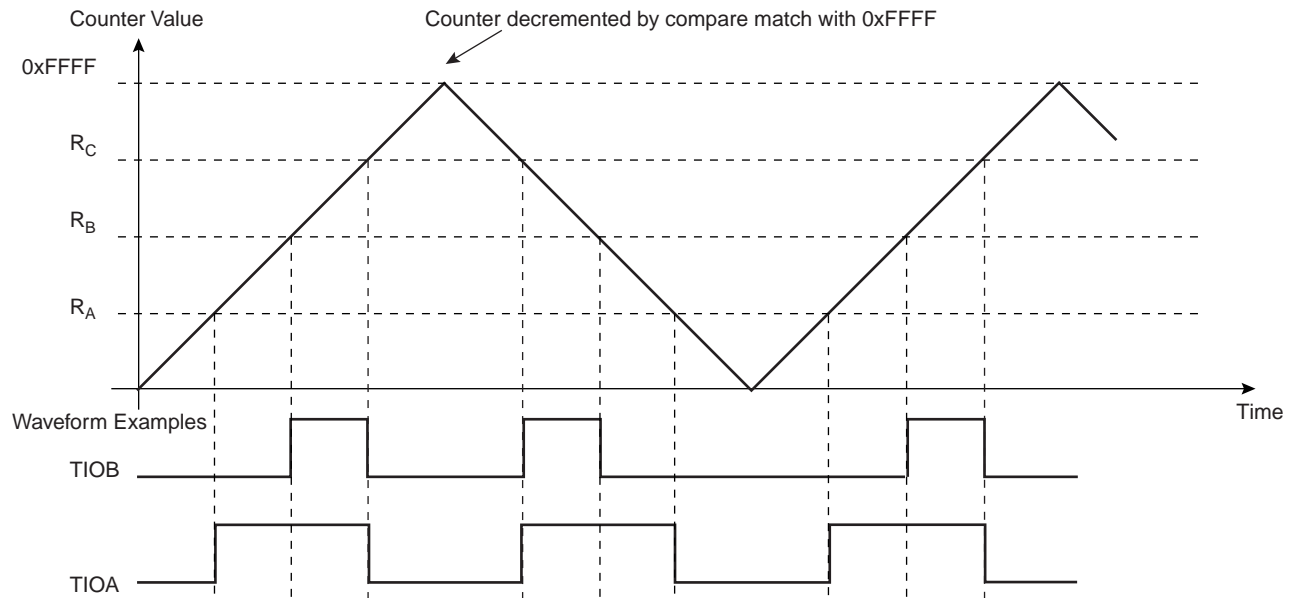
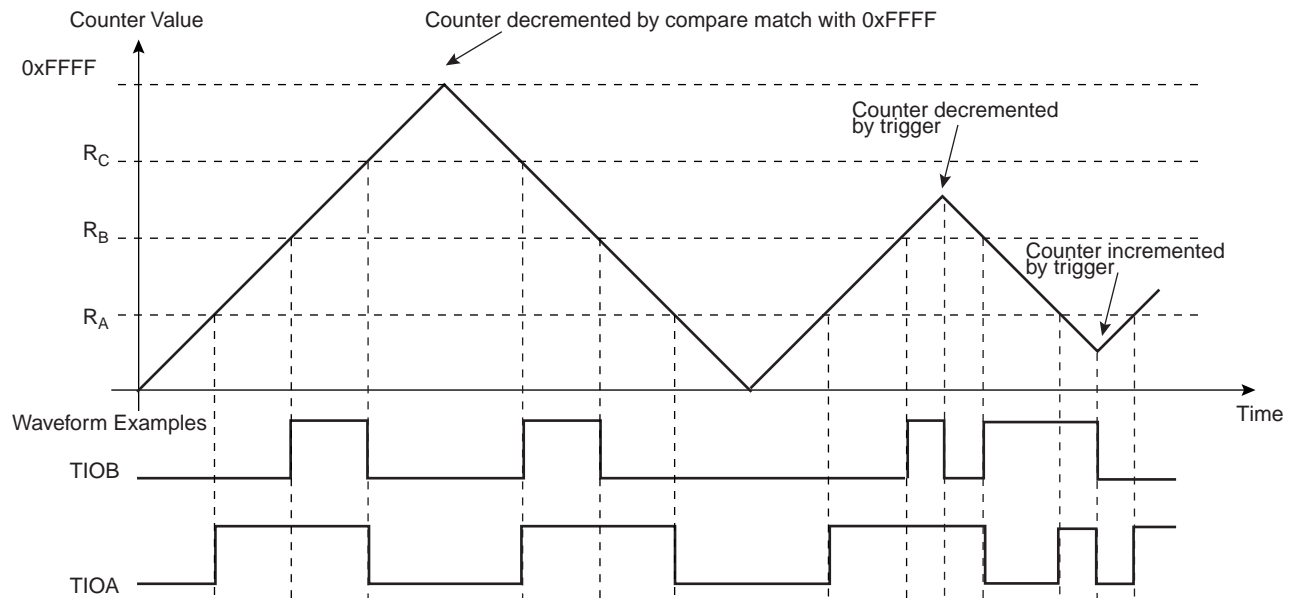

Figure 35-12. WAVSEL = 01 With Trigger



35.6.11.4 WAVSEL = 11

When WAVSEL = 11, the value of TC_CV is incremented from 0 to R_C. Once R_C is reached, the value of TC_CV is decremented to 0, then re-incremented to R_C and so on. See [Figure 35-13](#).

A trigger such as an external event or a software trigger can modify TC_CV at any time. If a trigger occurs while TC_CV is incrementing, TC_CV then decrements. If a trigger is received while TC_CV is decrementing, TC_CV then increments. See [Figure 35-14](#).

R_C Compare can stop the counter clock (CPCSTOP = 1) and/or disable the counter clock (CPCDIS = 1).

Figure 35-13. WAVSEL = 11 Without Trigger

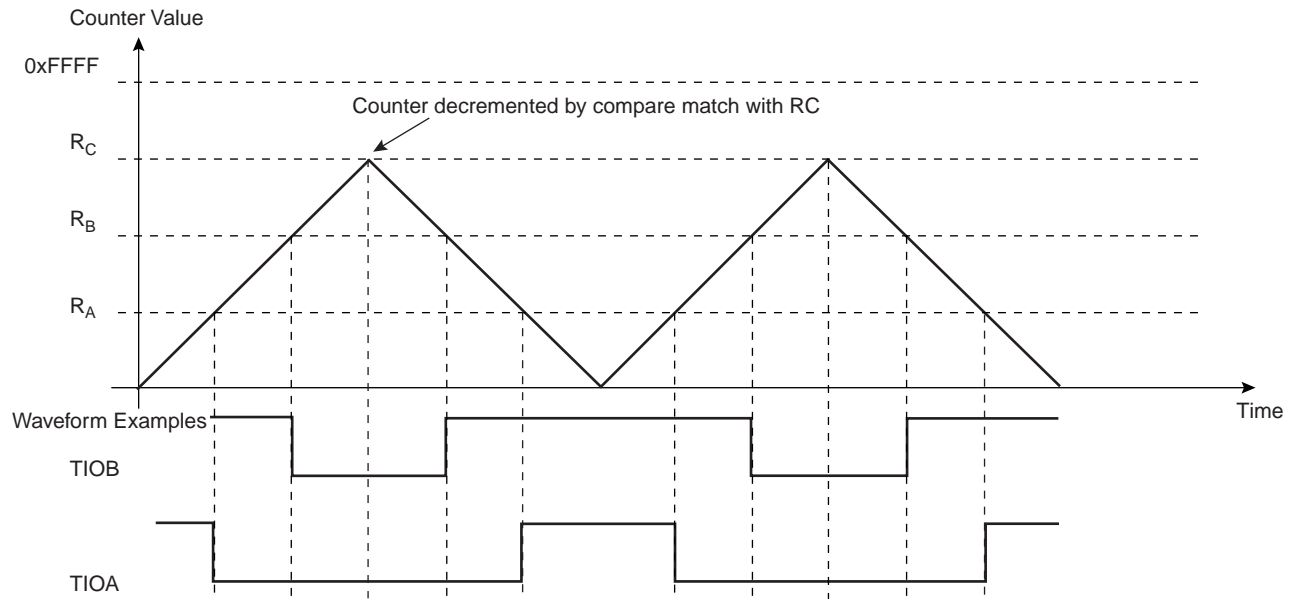
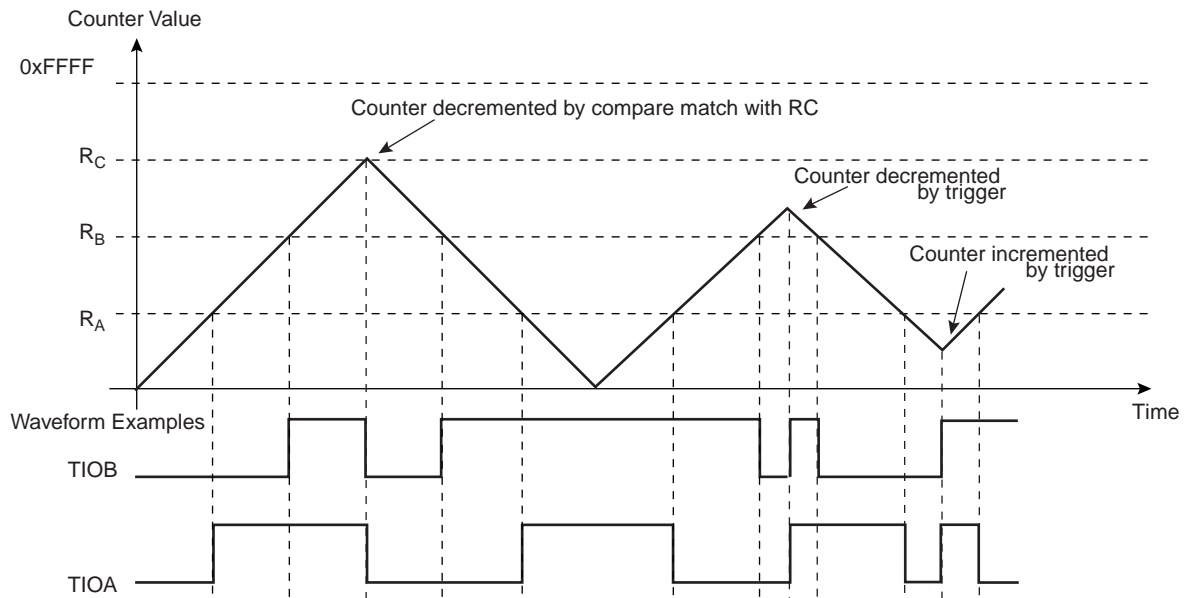

Figure 35-14. WAVSEL = 11 With Trigger



35.6.12 External Event/Trigger Conditions

An external event can be programmed to be detected on one of the clock sources (XC0, XC1, XC2) or TIOB. The external event selected can then be used as a trigger.

The EEVT parameter in TC_CMR selects the external trigger. The EEVTEG parameter defines the trigger edge for each of the possible external triggers (rising, falling or both). If EEVTEG is cleared (none), no external event is defined.

If TIOB is defined as an external event signal (EEVT = 0), TIOB is no longer used as an output and the compare register B is not used to generate waveforms and subsequently no IRQs. In this case the TC channel can only generate a waveform on TIOA.

When an external event is defined, it can be used as a trigger by setting bit ENETR in TC_CMR.

As in Capture Mode, the SYNC signal and the software trigger are also available as triggers. RC Compare can also be used as a trigger depending on the parameter WAVSEL.

35.6.13 Output Controller

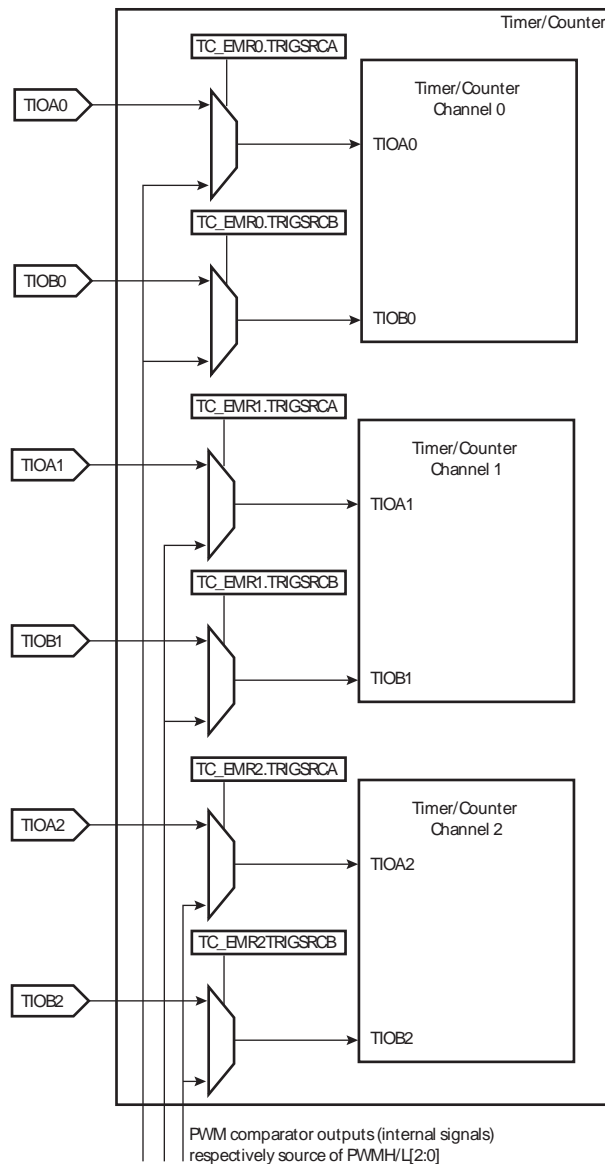

The output controller defines the output level changes on TIOA and TIOB following an event. TIOB control is used only if TIOB is defined as output (not as an external event).

The following events control TIOA and TIOB: software trigger, external event and RC compare. RA compare controls TIOA and RB compare controls TIOB. Each of these events can be programmed to set, clear or toggle the output as defined in the corresponding parameter in TC_CMR.

35.6.14 Quadrature Decoder Logic

35.6.14.1 Description

The quadrature decoder logic is driven by TIOA0, TIOB0, TIOB1 input pins and drives the timer/counter of channel 0 and 1. Channel 2 can be used as a time base in case of speed measurement requirements (refer to [Figure 35.7 "Timer Counter \(TC\) User Interface"](#)).



When writing 0 in the QDEN field of the TC_BMR register, the quadrature decoder logic is totally transparent.

TIOA0 and TIOB0 are to be driven by the 2 dedicated quadrature signals from a rotary sensor mounted on the shaft of the off-chip motor.

A third signal from the rotary sensor can be processed through pin TIOB1 and is typically dedicated to be driven by an index signal if it is provided by the sensor. This signal is not required to decode the quadrature signals PHA, PHB.

TCCLKS field of TC_CMR channels must be configured to select XC0 input (i.e. 0x101). TC0XC0S field has no effect as soon as quadrature decoder is enabled.

Either speed or position/revolution can be measured. Position channel 0 accumulates the edges of PHA, PHB input signals giving a high accuracy on motor position whereas channel 1 accumulates the index pulses of the sensor, therefore the number of rotations. Concatenation of both values provides a high level of precision on motion system position.

In speed mode, position cannot be measured but revolution can be measured.

Inputs from the rotary sensor can be filtered prior to down-stream processing. Accommodation of input polarity, phase definition and other factors are configurable.

Interruptions can be generated on different events.

A compare function (using TC_RC register) is available on channel 0 (speed/position) or channel 1 (rotation) and can generate an interrupt by means of the CPCS flag in the TC_SR registers.

Figure 35-15. Predefined Connection of the Quadrature Decoder with Timer Counters

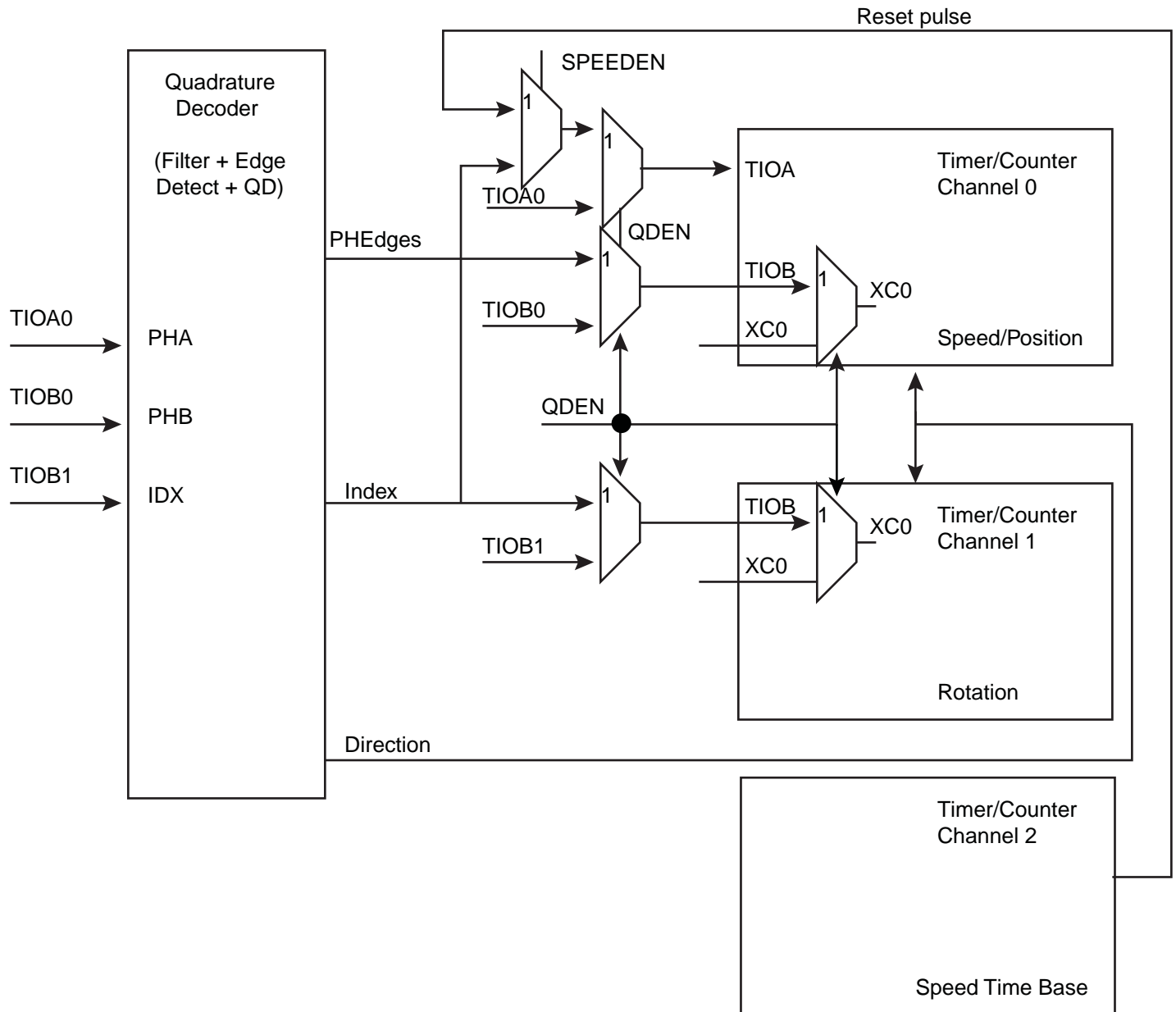

35.6.14.2 Input Pre-processing

Input pre-processing consists of capabilities to take into account rotary sensor factors such as polarities and phase definition followed by configurable digital filtering.

Each input can be negated and swapping PHA, PHB is also configurable.

By means of the MAXFILT field in TC_BMR, it is possible to configure a minimum duration for which the pulse is stated as valid. When the filter is active, pulses with a duration lower than $\text{MAXFILT} + 1 * \text{tMCK ns}$ are not passed to down-stream logic.

Filters can be disabled using the FILTER field in the TC_BMR register.

Figure 35-16. Input Stage

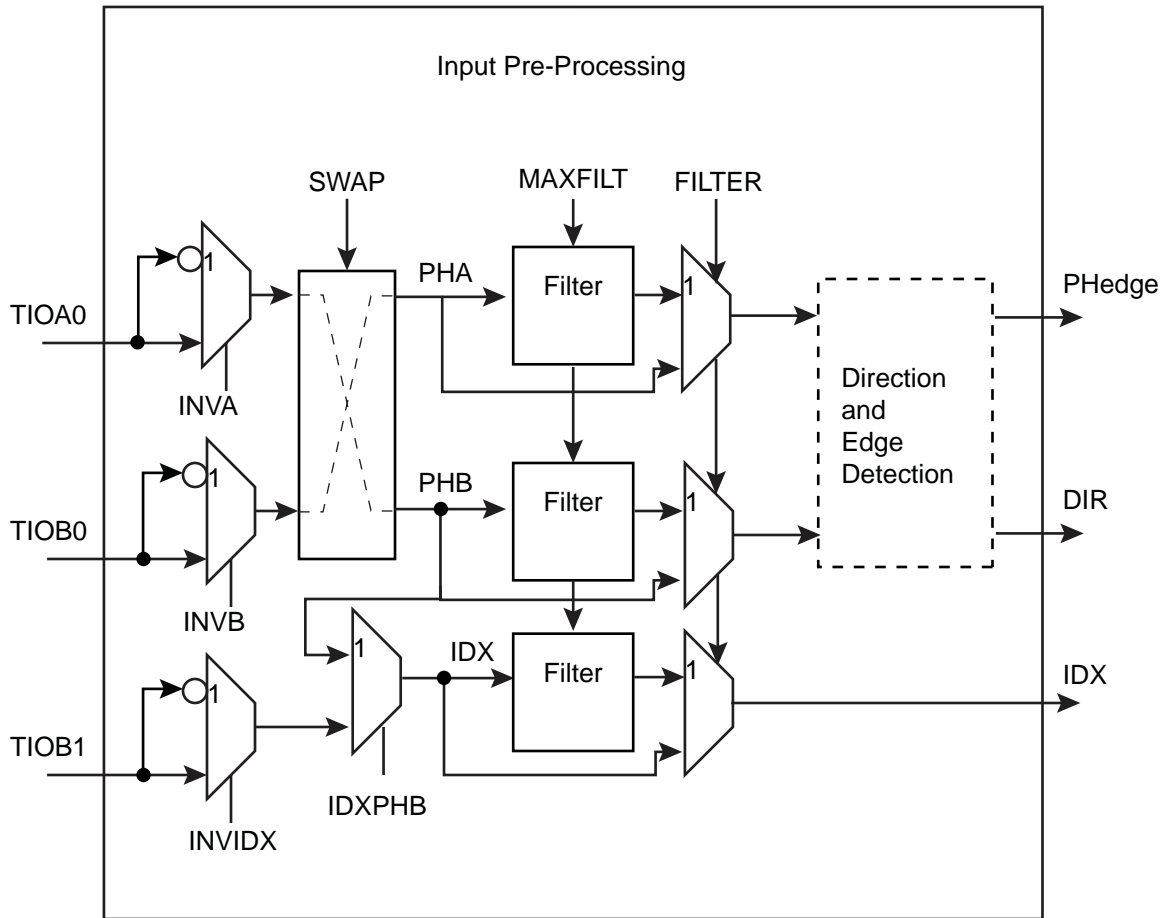

Input filtering can efficiently remove spurious pulses that might be generated by the presence of particulate contamination on the optical or magnetic disk of the rotary sensor.

Spurious pulses can also occur in environments with high levels of electro-magnetic interference. Or, simply if vibration occurs even when rotation is fully stopped and the shaft of the motor is in such a position that the beginning of one of the reflective or magnetic bars on the rotary sensor disk is aligned with the light or magnetic (Hall) receiver cell of the rotary sensor. Any vibration can make the PHA, PHB signals toggle for a short duration.

Figure 35-17. Filtering Examples

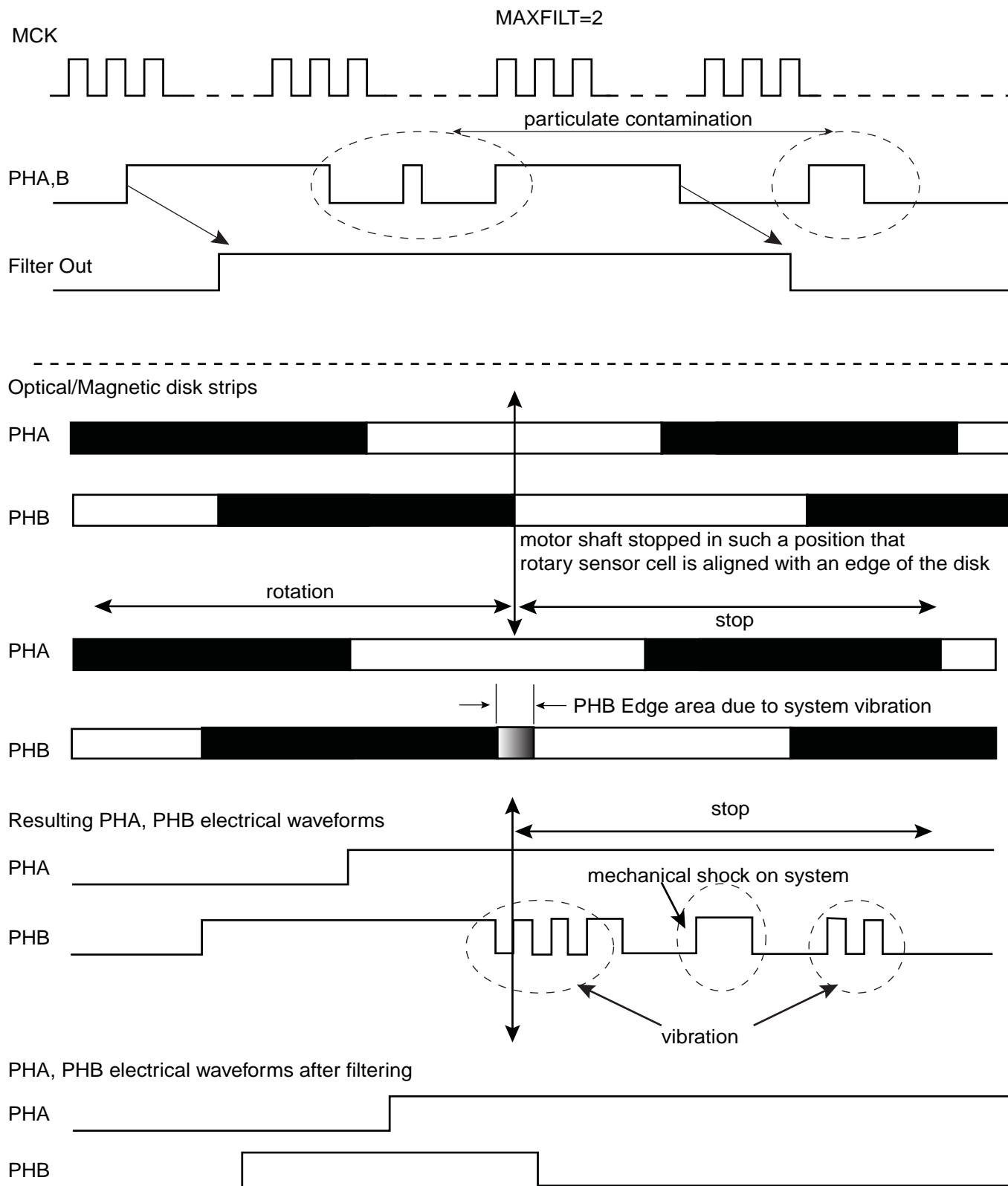

35.6.14.3 Direction Status and Change Detection

After filtering, the quadrature signals are analyzed to extract the rotation direction and edges of the 2 quadrature signals detected in order to be counted by timer/counter logic downstream.

The direction status can be directly read at anytime on TC_QISR register. The polarity of the direction flag status depends on the configuration written in TC_BMR register. INVA, INVB, INVIDX, SWAP modify the polarity of DIR flag.

Any change in rotation direction is reported on TC_QISR register and can generate an interrupt.

The direction change condition is reported as soon as 2 consecutive edges on a phase signal have sampled the same value on the other phase signal and there is an edge on the other signal. The 2 consecutive edges of 1 phase signal sampling the same value on other phase signal is not sufficient to declare a direction change, for the reason that particulate contamination may mask one or more reflective bar on the optical or magnetic disk of the sensor. (Refer to [Figure 35-18 "Rotation Change Detection"](#) for waveforms.)

Figure 35-18. Rotation Change Detection

Direction Change under normal conditions

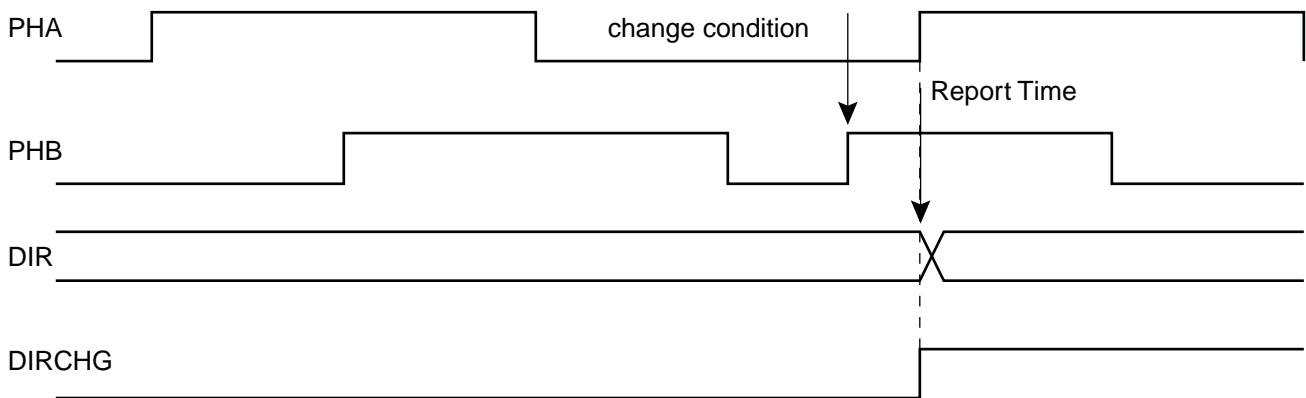

No direction change due to particulate contamination masking a reflective bar

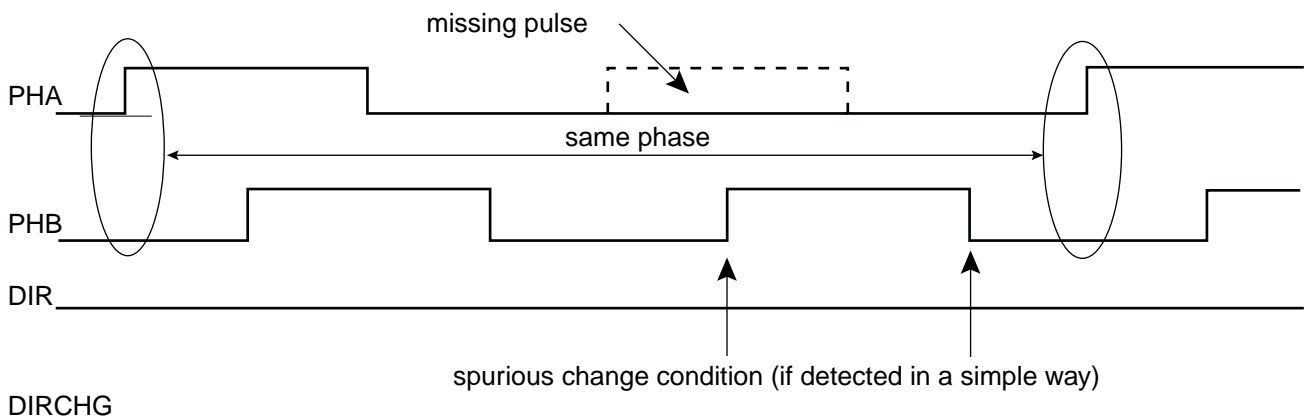

The direction change detection is disabled when QDTRANS is set to 1 in TC_BMR. In this case the DIR flag report must not be used.

A quadrature error is also reported by the quadrature decoder logic. Rather than reporting an error only when 2 edges occur at the same time on PHA and PHB, which is unlikely to occur in real life, there is a report if the time difference between 2 edges on PHA, PHB is lower than a predefined value. This predefined value is configurable and corresponds to $(MAXFILT+1) * tMCK$ ns. After being filtered there is no reason to have 2 edges closer than $(MAXFILT+1) * tMCK$ ns under normal mode of operation. In the instance an anomaly occurs, a quadrature error is reported on QERR flag on TC_QISR register.

Figure 35-19. Quadrature Error Detection

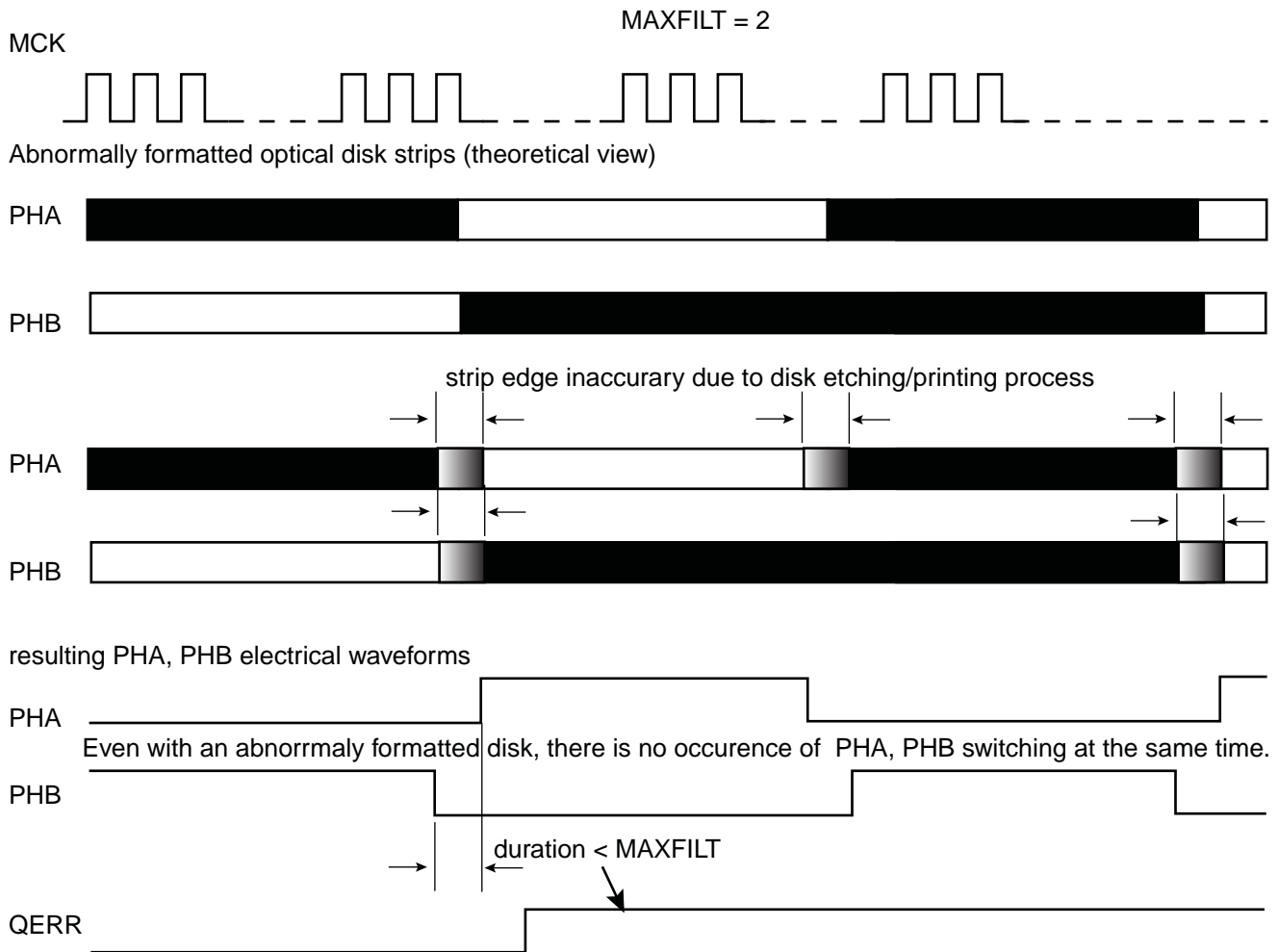

MAXFILT must be tuned according to several factors such as the system clock frequency (MCK), type of rotary sensor and rotation speed to be achieved.

35.6.14.4 Position and Rotation Measurement

When POSEN is set in TC_BMR register, position is processed on channel 0 (by means of the PHA,PHB edge detections) and motor revolutions are accumulated in channel 1 timer/counter and can be read through TC_CV0 and/or TC_CV1 register if the IDX signal is provided on TIOB1 input.

Channel 0 and 1 must be configured in capture mode (WAVE = 0 in TC_CMR0).

In parallel, the number of edges are accumulated on timer/counter channel 0 and can be read on the TC_CV0 register.

Therefore, the accurate position can be read on both TC_CV registers and concatenated to form a 32-bit word.

The timer/counter channel 0 is cleared for each increment of IDX count value.

Depending on the quadrature signals, the direction is decoded and allows to count up or down in timer/counter channels 0 and 1. The direction status is reported on TC_QISR register.

35.6.14.5 *Speed Measurement*

When SPEEDEN is set in TC_BMR register, the speed measure is enabled on channel 0.

A time base must be defined on channel 2 by writing the TC_RC2 period register. Channel 2 must be configured in waveform mode (WAVE bit field set) in TC_CMR2 register. WAVSEL bit field must be defined with 0x10 to clear the counter by comparison and matching with TC_RC value. ACPC field must be defined at 0x11 to toggle TIOA output.

This time base is automatically fed back to TIOA of channel 0 when QDEN and SPEEDEN are set.

Channel 0 must be configured in capture mode (WAVE = 0 in TC_CMR0). ABETRГ bit field of TC_CMR0 must be configured at 1 to get TIOA as a trigger for this channel.

EDGTRG can be set to 0x01, to clear the counter on a rising edge of the TIOA signal and LDRA field must be set accordingly to 0x01, to load TC_RA0 at the same time as the counter is cleared (LDRB must be set to 0x01). As a consequence, at the end of each time base period the differentiation required for the speed calculation is performed.

The process must be started by configuring the TC_CR register with CLKEN and SWTRG.

The speed can be read on TC_RA0 register in TC_CMR0.

Channel 1 can still be used to count the number of revolutions of the motor.

35.6.15 **2-bit Gray Up/Down Counter for Stepper Motor**

Each channel can be independently configured to generate a 2-bit gray count waveform on corresponding TIOA, TIOB outputs by means of GCEN bit in TC_SMMRx registers.

Up or Down count can be defined by writing bit DOWN in TC_SMMRx registers.

It is mandatory to configure the channel in WAVE mode in TC_CMR register.

The period of the counters can be programmed on TC_RCx registers.

Figure 35-20. 2-bit Gray Up/Down Counter.

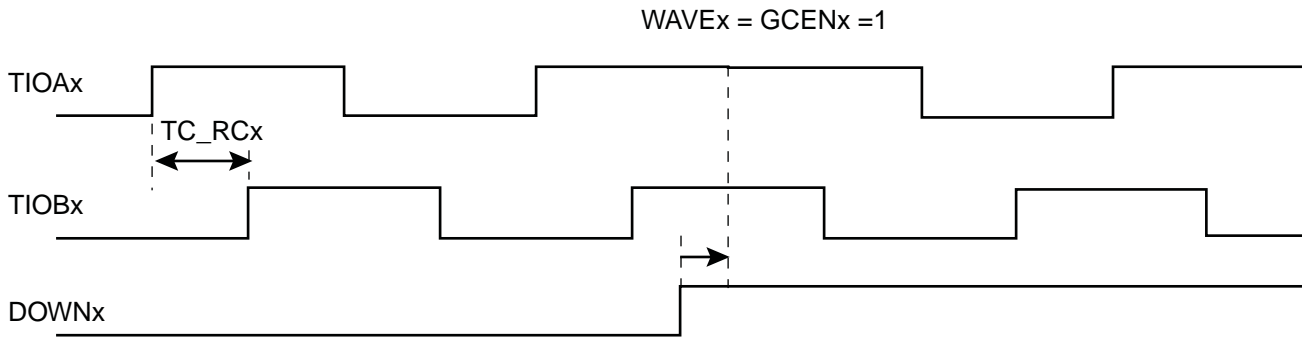

35.6.16 Write Protection System

In order to bring security to the Timer Counter, a write protection system has been implemented.

The write protection mode prevent the write of TC_BMR, TC_FMR, TC_CMRx, TC_SMMRx, TC_RAx, TC_RBx, TC_RCx registers. When this mode is enabled and one of the protected registers write, the register write request canceled.

Due to the nature of the write protection feature, enabling and disabling the write protection mode requires the use of a security code. Thus when enabling or disabling the write protection mode the WPKEY field of the TC_WPMR register must be filled with the "TIM" ASCII code (corresponding to 0x54494D) otherwise the register write will be canceled.

35.6.17 Fault Mode

At anytime, the TC_RCx registers can be used to perform a comparison on the respective current channel counter value (TC_CVx) with the value of TC_RCx register.

The CPCSx flags can be set accordingly and an interrupt can be generated.

This interrupt is processed but requires an unpredictable amount of time to be achieve the required action.

It is possible to trigger the FAULT output of the TIMER1 with CPCS from TC_SR0 register and/or CPCS from TC_SR1 register. Each source can be independently enabled/disabled by means of TC_FMR register.

This can be useful to detect an overflow on speed and/or position when QDEC is processed and to act immediately by using the FAULT output.

Figure 35-21. Fault Output Generation

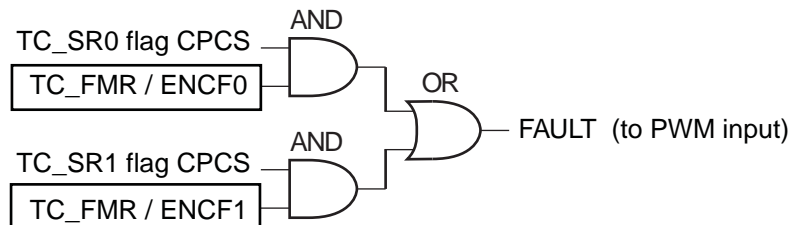

35.7 Timer Counter (TC) User Interface

Table 35-5. Register Mapping

Offset ⁽¹⁾	Register	Name	Access	Reset
0x00 + channel * 0x40 + 0x00	Channel Control Register	TC_CCR	Write-only	–
0x00 + channel * 0x40 + 0x04	Channel Mode Register	TC_CMR	Read-write	0
0x00 + channel * 0x40 + 0x08	Stepper Motor Mode Register	TC_SMMR	Read-write	0
0x00 + channel * 0x40 + 0x0C	Reserved			
0x00 + channel * 0x40 + 0x10	Counter Value	TC_CV	Read-only	0
0x00 + channel * 0x40 + 0x14	Register A	TC_RA	Read-write ⁽²⁾	0
0x00 + channel * 0x40 + 0x18	Register B	TC_RB	Read-write ⁽²⁾	0
0x00 + channel * 0x40 + 0x1C	Register C	TC_RC	Read-write	0
0x00 + channel * 0x40 + 0x20	Status Register	TC_SR	Read-only	0
0x00 + channel * 0x40 + 0x24	Interrupt Enable Register	TC_IER	Write-only	–
0x00 + channel * 0x40 + 0x28	Interrupt Disable Register	TC_IDR	Write-only	–
0x00 + channel * 0x40 + 0x2C	Interrupt Mask Register	TC_IMR	Read-only	0
0xC0	Block Control Register	TC_BCR	Write-only	–
0xC4	Block Mode Register	TC_BMR	Read-write	0
0xC8	QDEC Interrupt Enable Register	TC_QIER	Write-only	–
0xCC	QDEC Interrupt Disable Register	TC_QIDR	Write-only	–
0xD0	QDEC Interrupt Mask Register	TC_QIMR	Read-only	0
0xD4	QDEC Interrupt Status Register	TC_QISR	Read-only	0
0xD8	Fault Mode Register	TC_FMR	Read-write	0
0xE4	Write Protect Mode Register	TC_WPMR	Read-write	0
0xE8 - 0xFC	Reserved	–	–	–

Notes: 1. Channel index ranges from 0 to 2.
2. Read-only if WAVE = 0

35.7.1 TC Channel Control Register

Name: TC_CCRx [x=0..2]

Address: 0x40010000 (0)[0], 0x40010040 (0)[1], 0x40010080 (0)[2], 0x40014000 (1)[0], 0x40014040 (1)[1],
0x40014080 (1)[2]

Access: Write-only

31	30	29	28	27	26	25	24
–	–	–	–	–	–	–	–
23	22	21	20	19	18	17	16
–	–	–	–	–	–	–	–
15	14	13	12	11	10	9	8
–	–	–	–	–	–	–	–
7	6	5	4	3	2	1	0
–	–	–	–	–	SWTRG	CLKDIS	CLKEN

- **CLKEN: Counter Clock Enable Command**

0 = No effect.

1 = Enables the clock if CLKDIS is not 1.

- **CLKDIS: Counter Clock Disable Command**

0 = No effect.

1 = Disables the clock.

- **SWTRG: Software Trigger Command**

0 = No effect.

1 = A software trigger is performed: the counter is reset and the clock is started.

35.7.2 TC Channel Mode Register: Capture Mode

Name: TC_CM Rx [x=0..2] (WAVE = 0)

Address: 0x40010004 (0)[0], 0x40010044 (0)[1], 0x40010084 (0)[2], 0x40014004 (1)[0], 0x40014044 (1)[1],
0x40014084 (1)[2]

Access: Read-write

31	30	29	28	27	26	25	24
–	–	–	–	–	–	–	–
23	22	21	20	19	18	17	16
–	–	–	–	LDRB		LDRA	
15	14	13	12	11	10	9	8
WAVE	CPCTRG	–	–	–	ABETRG	ETRGEDG	
7	6	5	4	3	2	1	0
LDBDIS	LDBSTOP	BURST		CLKI	TCCLKS		

This register can only be written if the WPEN bit is cleared in [“TC Write Protect Mode Register” on page 858](#)

- **TCCLKS: Clock Selection**

Value	Name	Description
0	TIMER_CLOCK1	Clock selected: TCLK1
1	TIMER_CLOCK2	Clock selected: TCLK2
2	TIMER_CLOCK3	Clock selected: TCLK3
3	TIMER_CLOCK4	Clock selected: TCLK4
4	TIMER_CLOCK5	Clock selected: TCLK5
5	XC0	Clock selected: XC0
6	XC1	Clock selected: XC1
7	XC2	Clock selected: XC2

- **CLKI: Clock Invert**

0 = Counter is incremented on rising edge of the clock.

1 = Counter is incremented on falling edge of the clock.

- **BURST: Burst Signal Selection**

Value	Name	Description
0	NONE	The clock is not gated by an external signal.
1	XC0	XC0 is ANDed with the selected clock.
2	XC1	XC1 is ANDed with the selected clock.
3	XC2	XC2 is ANDed with the selected clock.

- **LDBSTOP: Counter Clock Stopped with RB Loading**

0 = Counter clock is not stopped when RB loading occurs.

1 = Counter clock is stopped when RB loading occurs.

- **LDBDIS: Counter Clock Disable with RB Loading**

0 = Counter clock is not disabled when RB loading occurs.

1 = Counter clock is disabled when RB loading occurs.

- **ETRGEDG: External Trigger Edge Selection**

Value	Name	Description
0	NONE	The clock is not gated by an external signal.
1	RISING	Rising edge
2	FALLING	Falling edge
3	EDGE	Each edge

- **ABETRG: TIOA or TIOB External Trigger Selection**

0 = TIOB is used as an external trigger.

1 = TIOA is used as an external trigger.

- **CPCTR: RC Compare Trigger Enable**

0 = RC Compare has no effect on the counter and its clock.

1 = RC Compare resets the counter and starts the counter clock.

- **WAVE: Waveform Mode**

0 = Capture Mode is enabled.

1 = Capture Mode is disabled (Waveform Mode is enabled).

- **LDRA: RA Loading Edge Selection**

Value	Name	Description
0	NONE	None
1	RISING	Rising edge of TIOA
2	FALLING	Falling edge of TIOA
3	EDGE	Each edge of TIOA

- **LDRB: RB Loading Edge Selection**

Value	Name	Description
0	NONE	None
1	RISING	Rising edge of TIOA
2	FALLING	Falling edge of TIOA
3	EDGE	Each edge of TIOA

35.7.3 TC Channel Mode Register: Waveform Mode

Name: TC_CMRx [x=0..2] (WAVE = 1)

Access: Read-write

31	30	29	28	27	26	25	24
BSWTRG		BEEVT		BCPC		BCPB	
23	22	21	20	19	18	17	16
ASWTRG		AEEVT		ACPC		ACPA	
15	14	13	12	11	10	9	8
WAVE	WAVSEL		ENETRГ	EEVT		EEVTEDG	
7	6	5	4	3	2	1	0
CPCDIS	CPCSTOP	BURST		CLKI	TCCLKS		

This register can only be written if the WPEN bit is cleared in “TC Write Protect Mode Register” on page 858

- **TCCLKS: Clock Selection**

Value	Name	Description
0	TIMER_CLOCK1	Clock selected: TCLK1
1	TIMER_CLOCK2	Clock selected: TCLK2
2	TIMER_CLOCK3	Clock selected: TCLK3
3	TIMER_CLOCK4	Clock selected: TCLK4
4	TIMER_CLOCK5	Clock selected: TCLK5
5	XC0	Clock selected: XC0
6	XC1	Clock selected: XC1
7	XC2	Clock selected: XC2

- **CLKI: Clock Invert**

0 = Counter is incremented on rising edge of the clock.

1 = Counter is incremented on falling edge of the clock.

- **BURST: Burst Signal Selection**

Value	Name	Description
0	NONE	The clock is not gated by an external signal.
1	XC0	XC0 is ANDed with the selected clock.
2	XC1	XC1 is ANDed with the selected clock.
3	XC2	XC2 is ANDed with the selected clock.

- **CPCSTOP: Counter Clock Stopped with RC Compare**

0 = Counter clock is not stopped when counter reaches RC.

1 = Counter clock is stopped when counter reaches RC.

- **CPCDIS: Counter Clock Disable with RC Compare**

0 = Counter clock is not disabled when counter reaches RC.

1 = Counter clock is disabled when counter reaches RC.

- **EEVTEDG: External Event Edge Selection**

Value	Name	Description
0	NONE	None
1	RISING	Rising edge
2	FALLING	Falling edge
3	EDGE	Each edge

- **EEVT: External Event Selection**

Signal selected as external event.

Value	Name	Description	TIOB Direction
0	TIOB	TIOB ⁽¹⁾	input
1	XC0	XC0	output
2	XC1	XC1	output
3	XC2	XC2	output

Note: 1. If TIOB is chosen as the external event signal, it is configured as an input and no longer generates waveforms and subsequently no IRQs.

- **ENETRГ: External Event Trigger Enable**

0 = The external event has no effect on the counter and its clock. In this case, the selected external event only controls the TIOA output.

1 = The external event resets the counter and starts the counter clock.

- **WAVSEL: Waveform Selection**

Value	Name	Description
0	UP	UP mode without automatic trigger on RC Compare
1	UPDOWN	UPDOWN mode without automatic trigger on RC Compare
2	UP_RC	UP mode with automatic trigger on RC Compare
3	UPDOWN_RC	UPDOWN mode with automatic trigger on RC Compare

- **WAVE: Waveform Mode**

0 = Waveform Mode is disabled (Capture Mode is enabled).

1 = Waveform Mode is enabled.

- **ACPA: RA Compare Effect on TIOA**

Value	Name	Description
0	NONE	None
1	SET	Set
2	CLEAR	Clear
3	TOGGLE	Toggle

- **ACPC: RC Compare Effect on TIOA**

Value	Name	Description
0	NONE	None
1	SET	Set
2	CLEAR	Clear
3	TOGGLE	Toggle

- **AEEVT: External Event Effect on TIOA**

Value	Name	Description
0	NONE	None
1	SET	Set
2	CLEAR	Clear
3	TOGGLE	Toggle

- **ASWTRG: Software Trigger Effect on TIOA**

Value	Name	Description
0	NONE	None
1	SET	Set
2	CLEAR	Clear
3	TOGGLE	Toggle

- **BCPB: RB Compare Effect on TIOB**

Value	Name	Description
0	NONE	None
1	SET	Set
2	CLEAR	Clear
3	TOGGLE	Toggle

- **BCPC: RC Compare Effect on TIOB**

Value	Name	Description
0	NONE	None
1	SET	Set
2	CLEAR	Clear
3	TOGGLE	Toggle

- **BEEVT: External Event Effect on TIOB**

Value	Name	Description
0	NONE	None
1	SET	Set
2	CLEAR	Clear
3	TOGGLE	Toggle

- **BSWTRG: Software Trigger Effect on TIOB**

Value	Name	Description
0	NONE	None
1	SET	Set
2	CLEAR	Clear
3	TOGGLE	Toggle

35.7.4 TC Stepper Motor Mode Register

Name: TC_SMMRx [x=0..2]

Address: 0x40010008 (0)[0], 0x40010048 (0)[1], 0x40010088 (0)[2], 0x40014008 (1)[0], 0x40014048 (1)[1],
0x40014088 (1)[2]

Access: Read-write

31	30	29	28	27	26	25	24
–	–	–	–	–	–	–	–
23	22	21	20	19	18	17	16
–	–	–	–	–	–	–	–
15	14	13	12	11	10	9	8
–	–	–	–	–	–	–	–
7	6	5	4	3	2	1	0
					–	DOWN	GCEN

This register can only be written if the WPEN bit is cleared in [“TC Write Protect Mode Register” on page 858](#)

- **GCEN: Gray Count Enable**

0 = TIOAx [x=0..2] and TIOBx [x=0..2] are driven by internal counter of channel x.

1 = TIOAx [x=0..2] and TIOBx [x=0..2] are driven by a 2-bit gray counter.

- **DOWN: DOWN Count**

0 = Up counter.

1 = Down counter.

35.7.5 TC Counter Value Register

Name: TC_CVx [x=0..2]

Address: 0x40010010 (0)[0], 0x40010050 (0)[1], 0x40010090 (0)[2], 0x40014010 (1)[0], 0x40014050 (1)[1],
0x40014090 (1)[2]

Access: Read-only

31	30	29	28	27	26	25	24
CV							
23	22	21	20	19	18	17	16
CV							
15	14	13	12	11	10	9	8
CV							
7	6	5	4	3	2	1	0
CV							

- **CV: Counter Value**

CV contains the counter value in real time.



35.7.6 TC Register A

Name: TC_RAx [x=0..2]

Address: 0x40010014 (0)[0], 0x40010054 (0)[1], 0x40010094 (0)[2], 0x40014014 (1)[0], 0x40014054 (1)[1],
0x40014094 (1)[2]

Access: Read-only if WAVE = 0, Read-write if WAVE = 1

31	30	29	28	27	26	25	24
RA							
23	22	21	20	19	18	17	16
RA							
15	14	13	12	11	10	9	8
RA							
7	6	5	4	3	2	1	0
RA							

This register can only be written if the WPEN bit is cleared in [“TC Write Protect Mode Register” on page 858](#)

- **RA: Register A**

RA contains the Register A value in real time.

35.7.7 TC Register B

Name: TC_RBx [x=0..2]

Address: 0x40010018 (0)[0], 0x40010058 (0)[1], 0x40010098 (0)[2], 0x40014018 (1)[0], 0x40014058 (1)[1],
0x40014098 (1)[2]

Access: Read-only if WAVE = 0, Read-write if WAVE = 1

31	30	29	28	27	26	25	24
RB							
23	22	21	20	19	18	17	16
RB							
15	14	13	12	11	10	9	8
RB							
7	6	5	4	3	2	1	0
RB							

This register can only be written if the WPEN bit is cleared in [“TC Write Protect Mode Register” on page 858](#)

- **RB: Register B**

RB contains the Register B value in real time.

35.7.8 TC Register C

Name: TC_RCx [x=0..2]

Address: 0x4001001C (0)[0], 0x4001005C (0)[1], 0x4001009C (0)[2], 0x4001401C (1)[0], 0x4001405C (1)[1],
0x4001409C (1)[2]

Access: Read-write

31	30	29	28	27	26	25	24
RC							
23	22	21	20	19	18	17	16
RC							
15	14	13	12	11	10	9	8
RC							
7	6	5	4	3	2	1	0
RC							

This register can only be written if the WPEN bit is cleared in [“TC Write Protect Mode Register” on page 858](#)

- **RC: Register C**

RC contains the Register C value in real time.

35.7.9 TC Status Register

Name: TC_SRx [x=0..2]

Address: 0x40010020 (0)[0], 0x40010060 (0)[1], 0x400100A0 (0)[2], 0x40014020 (1)[0], 0x40014060 (1)[1],
0x400140A0 (1)[2]

Access: Read-only

31	30	29	28	27	26	25	24
–	–	–	–	–	–	–	–
23	22	21	20	19	18	17	16
–	–	–	–	–	MTIOB	MTIOA	CLKSTA
15	14	13	12	11	10	9	8
–	–	–	–	–	–	–	–
7	6	5	4	3	2	1	0
ETRGS	LDRBS	LDRAS	CPCS	CPBS	CPAS	LOVRS	COVFS

- **COVFS: Counter Overflow Status**

0 = No counter overflow has occurred since the last read of the Status Register.

1 = A counter overflow has occurred since the last read of the Status Register.

- **LOVRS: Load Overrun Status**

0 = Load overrun has not occurred since the last read of the Status Register or WAVE = 1.

1 = RA or RB have been loaded at least twice without any read of the corresponding register since the last read of the Status Register, if WAVE = 0.

- **CPAS: RA Compare Status**

0 = RA Compare has not occurred since the last read of the Status Register or WAVE = 0.

1 = RA Compare has occurred since the last read of the Status Register, if WAVE = 1.

- **CPBS: RB Compare Status**

0 = RB Compare has not occurred since the last read of the Status Register or WAVE = 0.

1 = RB Compare has occurred since the last read of the Status Register, if WAVE = 1.

- **CPCS: RC Compare Status**

0 = RC Compare has not occurred since the last read of the Status Register.

1 = RC Compare has occurred since the last read of the Status Register.

- **LDRAS: RA Loading Status**

0 = RA Load has not occurred since the last read of the Status Register or WAVE = 1.

1 = RA Load has occurred since the last read of the Status Register, if WAVE = 0.

- **LDRBS: RB Loading Status**

0 = RB Load has not occurred since the last read of the Status Register or WAVE = 1.

1 = RB Load has occurred since the last read of the Status Register, if WAVE = 0.

- **ETRGS: External Trigger Status**

0 = External trigger has not occurred since the last read of the Status Register.

1 = External trigger has occurred since the last read of the Status Register.

- **CLKSTA: Clock Enabling Status**

0 = Clock is disabled.

1 = Clock is enabled.

- **MTIOA: TIOA Mirror**

0 = TIOA is low. If WAVE = 0, this means that TIOA pin is low. If WAVE = 1, this means that TIOA is driven low.

1 = TIOA is high. If WAVE = 0, this means that TIOA pin is high. If WAVE = 1, this means that TIOA is driven high.

- **MTIOB: TIOB Mirror**

0 = TIOB is low. If WAVE = 0, this means that TIOB pin is low. If WAVE = 1, this means that TIOB is driven low.

1 = TIOB is high. If WAVE = 0, this means that TIOB pin is high. If WAVE = 1, this means that TIOB is driven high.

35.7.10 TC Interrupt Enable Register

Name: TC_IERx [x=0..2]

Address: 0x40010024 (0)[0], 0x40010064 (0)[1], 0x400100A4 (0)[2], 0x40014024 (1)[0], 0x40014064 (1)[1],
0x400140A4 (1)[2]

Access: Write-only

31	30	29	28	27	26	25	24
–	–	–	–	–	–	–	–
23	22	21	20	19	18	17	16
–	–	–	–	–	–	–	–
15	14	13	12	11	10	9	8
–	–	–	–	–	–	–	–
7	6	5	4	3	2	1	0
ETRGS	LDRBS	LDRAS	CPCS	CPBS	CPAS	LOVRS	COVFS

- **COVFS: Counter Overflow**

0 = No effect.

1 = Enables the Counter Overflow Interrupt.

- **LOVRS: Load Overrun**

0 = No effect.

1 = Enables the Load Overrun Interrupt.

- **CPAS: RA Compare**

0 = No effect.

1 = Enables the RA Compare Interrupt.

- **CPBS: RB Compare**

0 = No effect.

1 = Enables the RB Compare Interrupt.

- **CPCS: RC Compare**

0 = No effect.

1 = Enables the RC Compare Interrupt.

- **LDRAS: RA Loading**

0 = No effect.

1 = Enables the RA Load Interrupt.

- **LDRBS: RB Loading**

0 = No effect.

1 = Enables the RB Load Interrupt.

- **ETRGS: External Trigger**

0 = No effect.

1 = Enables the External Trigger Interrupt.

35.7.11 TC Interrupt Disable Register

Name: TC_IDRx [x=0..2]

Address: 0x40010028 (0)[0], 0x40010068 (0)[1], 0x400100A8 (0)[2], 0x40014028 (1)[0], 0x40014068 (1)[1],
0x400140A8 (1)[2]

Access: Write-only

31	30	29	28	27	26	25	24
–	–	–	–	–	–	–	–
23	22	21	20	19	18	17	16
–	–	–	–	–	–	–	–
15	14	13	12	11	10	9	8
–	–	–	–	–	–	–	–
7	6	5	4	3	2	1	0
ETRGS	LDRBS	LDRAS	CPCS	CPBS	CPAS	LOVRS	COVFS

- **COVFS: Counter Overflow**

0 = No effect.

1 = Disables the Counter Overflow Interrupt.

- **LOVRS: Load Overrun**

0 = No effect.

1 = Disables the Load Overrun Interrupt (if WAVE = 0).

- **CPAS: RA Compare**

0 = No effect.

1 = Disables the RA Compare Interrupt (if WAVE = 1).

- **CPBS: RB Compare**

0 = No effect.

1 = Disables the RB Compare Interrupt (if WAVE = 1).

- **CPCS: RC Compare**

0 = No effect.

1 = Disables the RC Compare Interrupt.

- **LDRAS: RA Loading**

0 = No effect.

1 = Disables the RA Load Interrupt (if WAVE = 0).

- **LDRBS: RB Loading**

0 = No effect.

1 = Disables the RB Load Interrupt (if WAVE = 0).



- **ETRGS: External Trigger**

0 = No effect.

1 = Disables the External Trigger Interrupt.

35.7.12 TC Interrupt Mask Register

Name: TC_IMRx [x=0..2]

Address: 0x4001002C (0)[0], 0x4001006C (0)[1], 0x400100AC (0)[2], 0x4001402C (1)[0], 0x4001406C (1)[1],
0x400140AC (1)[2]

Access: Read-only

31	30	29	28	27	26	25	24
–	–	–	–	–	–	–	–
23	22	21	20	19	18	17	16
–	–	–	–	–	–	–	–
15	14	13	12	11	10	9	8
–	–	–	–	–	–	–	–
7	6	5	4	3	2	1	0
ETRGS	LDRBS	LDRAS	CPCS	CPBS	CPAS	LOVRS	COVFS

- **COVFS: Counter Overflow**

0 = The Counter Overflow Interrupt is disabled.

1 = The Counter Overflow Interrupt is enabled.

- **LOVRS: Load Overrun**

0 = The Load Overrun Interrupt is disabled.

1 = The Load Overrun Interrupt is enabled.

- **CPAS: RA Compare**

0 = The RA Compare Interrupt is disabled.

1 = The RA Compare Interrupt is enabled.

- **CPBS: RB Compare**

0 = The RB Compare Interrupt is disabled.

1 = The RB Compare Interrupt is enabled.

- **CPCS: RC Compare**

0 = The RC Compare Interrupt is disabled.

1 = The RC Compare Interrupt is enabled.

- **LDRAS: RA Loading**

0 = The Load RA Interrupt is disabled.

1 = The Load RA Interrupt is enabled.

- **LDRBS: RB Loading**

0 = The Load RB Interrupt is disabled.

1 = The Load RB Interrupt is enabled.

- **ETRGS: External Trigger**

0 = The External Trigger Interrupt is disabled.

1 = The External Trigger Interrupt is enabled.

35.7.13 TC Block Control Register

Name: TC_BCR

Address: 0x400100C0 (0), 0x400140C0 (1)

Access: Write-only

31	30	29	28	27	26	25	24
–	–	–	–	–	–	–	–
23	22	21	20	19	18	17	16
–	–	–	–	–	–	–	–
15	14	13	12	11	10	9	8
–	–	–	–	–	–	–	–
7	6	5	4	3	2	1	0
–	–	–	–	–	–	–	SYNC

- **SYNC: Synchro Command**

0 = No effect.

1 = Asserts the SYNC signal which generates a software trigger simultaneously for each of the channels.

35.7.14 TC Block Mode Register

Name: TC_BMR
Address: 0x400100C4 (0), 0x400140C4 (1)
Access: Read-write

31	30	29	28	27	26	25	24
–	–	–	–	–	–	MAXFILT	
23	22	21	20	19	18	17	16
MAXFILT				FILTER	–	IDXPBH	SWAP
15	14	13	12	11	10	9	8
INVIDX	INVB	INVA	EDGPHA	QDTRANS	SPEEDEN	POSEN	QDEN
7	6	5	4	3	2	1	0
–	–	TC2XC2S		TC1XC1S		TC0XC0S	

This register can only be written if the WPEN bit is cleared in “TC Write Protect Mode Register” on page 858.

- **TC0XC0S: External Clock Signal 0 Selection**

Value	Name	Description
0	TCLK0	Signal connected to XC0: TCLK0
1	–	Reserved
2	TIOA1	Signal connected to XC0: TIOA1
3	TIOA2	Signal connected to XC0: TIOA2

- **TC1XC1S: External Clock Signal 1 Selection**

Value	Name	Description
0	TCLK1	Signal connected to XC1: TCLK1
1	–	Reserved
2	TIOA0	Signal connected to XC1: TIOA0
3	TIOA2	Signal connected to XC1: TIOA2

- **TC2XC2S: External Clock Signal 2 Selection**

Value	Name	Description
0	TCLK2	Signal connected to XC2: TCLK2
1	–	Reserved
2	TIOA1	Signal connected to XC2: TIOA1
3	TIOA2	Signal connected to XC2: TIOA2

- **QDEN: Quadrature Decoder ENabled**

0 = Disabled.

1 = Enables the quadrature decoder logic (filter, edge detection and quadrature decoding).

Quadrature decoding (direction change) can be disabled using QDTRANS bit.

One of the POSEN or SPEEDEN bits must be also enabled.

- **POSEN: POSition ENabled**

0 = Disable position.

1 = Enables the position measure on channel 0 and 1.

- **SPEEDEN: SPEED ENabled**

0 = Disabled.

1 = Enables the speed measure on channel 0, the time base being provided by channel 2.

- **QDTRANS: Quadrature Decoding TRANSPARENT**

0 = Full quadrature decoding logic is active (direction change detected).

1 = Quadrature decoding logic is inactive (direction change inactive) but input filtering and edge detection are performed.

- **EDGPHA: EDGE on PHA count mode**

0 = Edges are detected on both PHA and PHB.

1 = Edges are detected on PHA only.

- **INVA: INVERTed pH**

0 = PHA (TIOA0) is directly driving quadrature decoder logic.

1 = PHA is inverted before driving quadrature decoder logic.

- **INVB: INVERTed pH**

0 = PHB (TIOB0) is directly driving quadrature decoder logic.

1 = PHB is inverted before driving quadrature decoder logic.

- **SWAP: SWAP PHA and PHB**

0 = No swap between PHA and PHB.

1 = Swap PHA and PHB internally, prior to driving quadrature decoder logic.

- **INVIDX: INVERTed InDeX**

0 = IDX (TIOA1) is directly driving quadrature logic.

1 = IDX is inverted before driving quadrature logic.

- **IDXPHB: InDeX pin is PHB pin**

0 = IDX pin of the rotary sensor must drive TIOA1.

1 = IDX pin of the rotary sensor must drive TIOB0.

- **FILTER:**

0 = IDX,PHA, PHB input pins are not filtered.

1 = IDX,PHA, PHB input pins are filtered using MAXFILT value.

- **MAXFILT: MAXimum FILTer**

1.. 63: Defines the filtering capabilities.

Pulses with a period shorter than MAXFILT+1 MCK clock cycles are discarded.

35.7.15 TC QDEC Interrupt Enable Register

Name: TC_QIER

Address: 0x400100C8 (0), 0x400140C8 (1)

Access: Write-only

31	30	29	28	27	26	25	24
–	–	–	–	–	–	–	–
23	22	21	20	19	18	17	16
–	–	–	–	–	–	–	–
15	14	13	12	11	10	9	8
–	–	–	–	–	–	–	–
7	6	5	4	3	2	1	0
–	–	–	–	–	QERR	DIRCHG	IDX

- **IDX: InDeX**

0 = No effect.

1 = Enables the interrupt when a rising edge occurs on IDX input.

- **DIRCHG: DIRection CHAnGe**

0 = No effect.

1 = Enables the interrupt when a change on rotation direction is detected.

- **QERR: Quadrature ERRor**

0 = No effect.

1 = Enables the interrupt when a quadrature error occurs on PHA,PHB.

35.7.16 TC QDEC Interrupt Disable Register

Name: TC_QIDR

Address: 0x400100CC (0), 0x400140CC (1)

Access: Write-only

31	30	29	28	27	26	25	24
–	–	–	–	–	–	–	–
23	22	21	20	19	18	17	16
–	–	–	–	–	–	–	–
15	14	13	12	11	10	9	8
–	–	–	–	–	–	–	–
7	6	5	4	3	2	1	0
–	–	–	–	–	QERR	DIRCHG	IDX

- **IDX: InDeX**

0 = No effect.

1 = Disables the interrupt when a rising edge occurs on IDX input.

- **DIRCHG: DIRection CHAnGe**

0 = No effect.

1 = Disables the interrupt when a change on rotation direction is detected.

- **QERR: Quadrature ERRor**

0 = No effect.

1 = Disables the interrupt when a quadrature error occurs on PHA, PHB.

35.7.17 TC QDEC Interrupt Mask Register

Name: TC_QIMR

Address: 0x400100D0 (0), 0x400140D0 (1)

Access: Read-only

31	30	29	28	27	26	25	24
–	–	–	–	–	–	–	–
23	22	21	20	19	18	17	16
–	–	–	–	–	–	–	–
15	14	13	12	11	10	9	8
–	–	–	–	–	–	–	–
7	6	5	4	3	2	1	0
–	–	–	–	–	QERR	DIRCHG	IDX

- **IDX: InDeX**

0 = The interrupt on IDX input is disabled.

1 = The interrupt on IDX input is enabled.

- **DIRCHG: DIRection CHAnGe**

0 = The interrupt on rotation direction change is disabled.

1 = The interrupt on rotation direction change is enabled.

- **QERR: Quadrature ERRor**

0 = The interrupt on quadrature error is disabled.

1 = The interrupt on quadrature error is enabled.

35.7.18 TC QDEC Interrupt Status Register

Name: TC_QISR

Address: 0x400100D4 (0), 0x400140D4 (1)

Access: Read-only

31	30	29	28	27	26	25	24
–	–	–	–	–	–	–	–
23	22	21	20	19	18	17	16
–	–	–	–	–	–	–	–
15	14	13	12	11	10	9	8
–	–	–	–	–	–	–	DIR
7	6	5	4	3	2	1	0
–	–	–	–	–	QERR	DIRCHG	IDX

- **IDX: InDeX**

0 = No Index input change since the last read of TC_QISR.

1 = The IDX input has changed since the last read of TC_QISR.

- **DIRCHG: DIRection CHAnGe**

0 = No change on rotation direction since the last read of TC_QISR.

1 = The rotation direction changed since the last read of TC_QISR.

- **QERR: Quadrature ERRor**

0 = No quadrature error since the last read of TC_QISR.

1 = A quadrature error occurred since the last read of TC_QISR.

- **DIR: DIRection**

Returns an image of the actual rotation direction.

35.7.19 TC Fault Mode Register

Name: TC_FMR

Address: 0x400100D8 (0), 0x400140D8 (1)

Access: Read-write

31	30	29	28	27	26	25	24
–	–	–	–	–	–	–	–
23	22	21	20	19	18	17	16
–	–	–	–	–	–	–	–
15	14	13	12	11	10	9	8
–	–	–	–	–	–	–	–
7	6	5	4	3	2	1	0
–	–	–	–	–	–	ENCF1	ENCF0

This register can only be written if the WPEN bit is cleared in [“TC Write Protect Mode Register” on page 858](#)

- **ENCF0: ENable Compare Fault Channel 0**

0 = Disables the FAULT output source (CPCS flag) from channel 0.

1 = Enables the FAULT output source (CPCS flag) from channel 0.

- **ENCF1: ENable Compare Fault Channel 1**

0 = Disables the FAULT output source (CPCS flag) from channel 1.

1 = Enables the FAULT output source (CPCS flag) from channel 1.



35.7.20 TC Write Protect Mode Register

Name: TC_WPMR
Address: 0x400100E4 (0), 0x400140E4 (1)
Access: Read-write

31	30	29	28	27	26	25	24
WPKEY							
23	22	21	20	19	18	17	16
WPKEY							
15	14	13	12	11	10	9	8
WPKEY							
7	6	5	4	3	2	1	0
-	-	-	-	-	-	-	WPEN

- **WPEN: Write Protect Enable**

0 = Disables the Write Protect if WPKEY corresponds to 0x54494D ("TIM" in ASCII).

1 = Enables the Write Protect if WPKEY corresponds to 0x54494D ("TIM" in ASCII).

Protects the registers:

- "TC Block Mode Register"
- "TC Channel Mode Register: Capture Mode"
- "TC Channel Mode Register: Waveform Mode"
- "TC Fault Mode Register"
- "TC Stepper Motor Mode Register"
- "TC Register A"
- "TC Register B"
- "TC Register C"

- **WPKEY: Write Protect KEY**

Should be written at value 0x54494D ("TIM" in ASCII). Writing any other value in this field aborts the write operation of the WPEN bit. Always reads as 0.

36. High Speed Multimedia Card Interface (HSMCI)

36.1 Description

The High Speed Multimedia Card Interface (HSMCI) supports the MultiMedia Card (MMC) Specification V4.3, the SD Memory Card Specification V2.0, the SDIO V2.0 specification and CE-ATA V1.1.

The HSMCI includes a command register, response registers, data registers, timeout counters and error detection logic that automatically handle the transmission of commands and, when required, the reception of the associated responses and data with a limited processor overhead.

The HSMCI supports stream, block and multi block data read and write, and is compatible with the Peripheral DMA Controller (PDC) Channels, minimizing processor intervention for large buffer transfers.

The HSMCI operates at a rate of up to Master Clock divided by 2 and supports the interfacing of 1 slot(s). Each slot may be used to interface with a High Speed MultiMediaCard bus (up to 30 Cards) or with an SD Memory Card. Only one slot can be selected at a time (slots are multiplexed). A bit field in the SD Card Register performs this selection.

The SD Memory Card communication is based on a 9-pin interface (clock, command, four data and three power lines) and the High Speed MultiMedia Card on a 7-pin interface (clock, command, one data, three power lines and one reserved for future use).

The SD Memory Card interface also supports High Speed MultiMedia Card operations. The main differences between SD and High Speed MultiMedia Cards are the initialization process and the bus topology.

HSMCI fully supports CE-ATA Revision 1.1, built on the MMC System Specification v4.0. The module includes dedicated hardware to issue the command completion signal and capture the host command completion signal disable.

36.2 Embedded Characteristics

- 4-bit or 1-bit Interface
- Compatibility with MultiMedia Card Specification Version 4.3
- Compatibility with SD and SDHC Memory Card Specification Version 2.0
- Compatibility with SDIO Specification Version V1.1.
- Compatibility with CE-ATA Specification 1.1
- Cards clock rate up to Master Clock divided by 2
- Boot Operation Mode support
- High Speed mode support
- Embedded power management to slow down clock rate when not used
- MCI has one slot supporting
 - One MultiMediaCard bus (up to 30 cards) or
 - One SD Memory Card
 - One SDIO Card
- Support for stream, block and multi-block data read and write

36.3 Block Diagram

Figure 36-1. Block Diagram

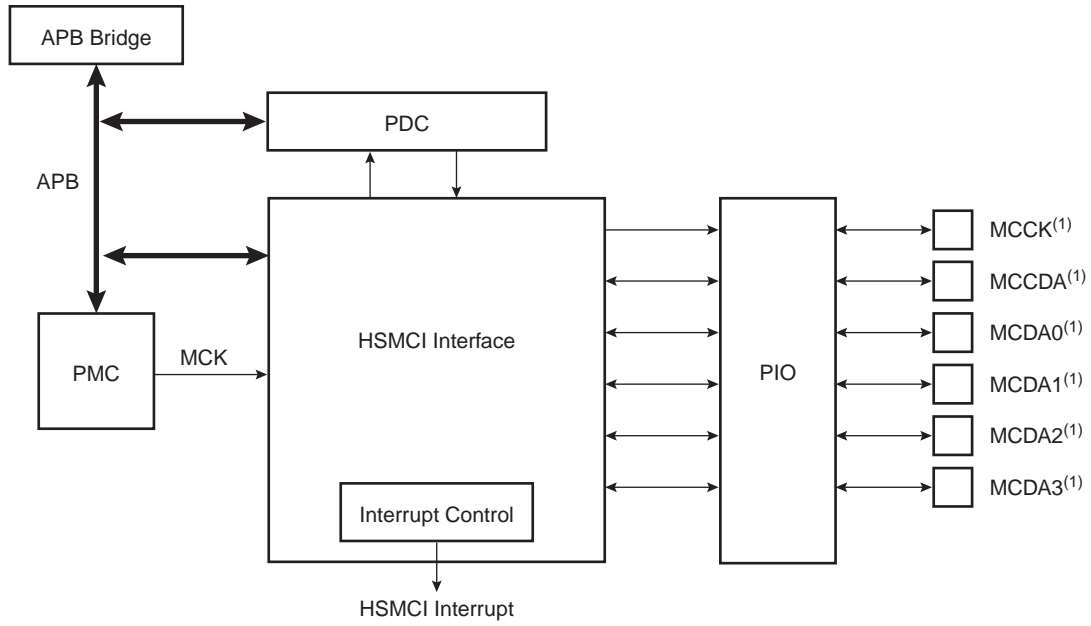

36.4 Application Block Diagram

Figure 36-2. Application Block Diagram

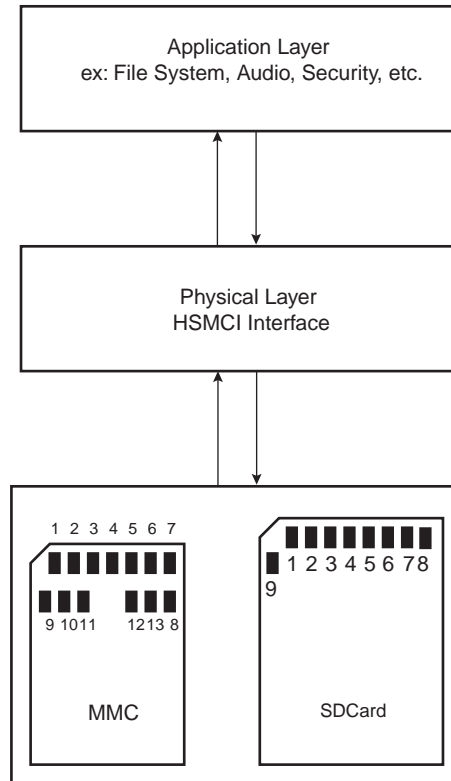

36.5 Pin Name List

Table 36-1. I/O Lines Description for 4-bit Configuration

Pin Name ⁽¹⁾	Pin Description	Type ⁽²⁾	Comments
MCCDA	Command/response	I/O/PP/OD	CMD of an MMC or SDCard/SDIO
MCCK	Clock	I/O	CLK of an MMC or SD Card/SDIO
MCDA0 - MCDA3	Data 0..3 of Slot A	I/O/PP	DAT[0..3] of an MMC DAT[0..3] of an SD Card/SDIO

- Notes:
1. When several HSMCI (x HSMCI) are embedded in a product, MCCK refers to HSMCIx_CK, MCCDA to HSMCIx_CDA, MCDAy to HSMCIx_DAY.
 2. I: Input, O: Output, PP: Push/Pull, OD: Open Drain.

36.6 Product Dependencies

36.6.1 I/O Lines

The pins used for interfacing the High Speed MultiMedia Cards or SD Cards are multiplexed with PIO lines. The programmer must first program the PIO controllers to assign the peripheral functions to HSMCI pins.

Table 36-2. I/O Lines

Instance	Signal	I/O Line	Peripheral
HSMCI	MCCDA	PA28	C
HSMCI	MCKK	PA29	C
HSMCI	MCDA0	PA30	C
HSMCI	MCDA1	PA31	C
HSMCI	MCDA2	PA26	C
HSMCI	MCDA3	PA27	C

36.6.2 Power Management

The HSMCI is clocked through the Power Management Controller (PMC), so the programmer must first configure the PMC to enable the HSMCI clock.

36.6.3 Interrupt

The HSMCI interface has an interrupt line connected to the Nested Vector Interrupt Controller (NVIC).

Handling the HSMCI interrupt requires programming the NVIC before configuring the HSMCI.

Table 36-3. Peripheral IDs

Instance	ID
HSMCI	18

36.7 Bus Topology

Figure 36-3. High Speed MultiMedia Memory Card Bus Topology

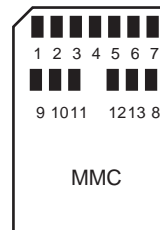

The High Speed MultiMedia Card communication is based on a 13-pin serial bus interface. It has three communication lines and four supply lines.

Table 36-4. Bus Topology

Pin Number	Name	Type ⁽¹⁾	Description	HSMCI Pin Name ⁽²⁾ (Slot z)
1	DAT[3]	I/O/PP	Data	MCDz3
2	CMD	I/O/PP/OD	Command/response	MCCDz
3	VSS1	S	Supply voltage ground	VSS
4	VDD	S	Supply voltage	VDD
5	CLK	I/O	Clock	MCKz
6	VSS2	S	Supply voltage ground	VSS
7	DAT[0]	I/O/PP	Data 0	MCDz0
8	DAT[1]	I/O/PP	Data 1	MCDz1
9	DAT[2]	I/O/PP	Data 2	MCDz2
10	DAT[4]	I/O/PP	Data 4	MCDz4
11	DAT[5]	I/O/PP	Data 5	MCDz5
12	DAT[6]	I/O/PP	Data 6	MCDz6
13	DAT[7]	I/O/PP	Data 7	MCDz7

Notes: 1. I: Input, O: Output, PP: Push/Pull, OD: Open Drain.

2. When several HSMCI (x HSMCI) are embedded in a product, MCKz refers to HSMCIx_CK, MCCDA to HSMCIx_CDA, MCDz to HSMCIx_Dz.

Figure 36-4. MMC Bus Connections (One Slot)

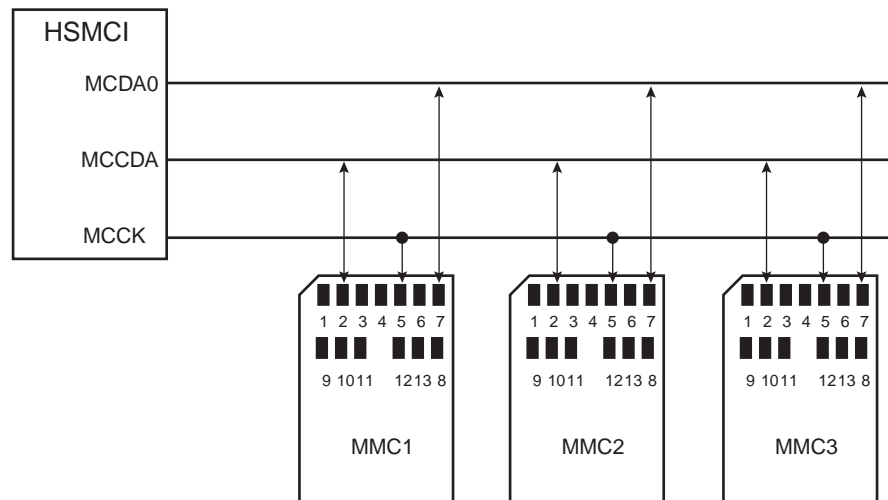

Note: When several HSMCI (x HSMCI) are embedded in a product, MCKz refers to HSMCIx_CK, MCCDA to HSMCIx_CDA, MCDz to HSMCIx_Dz.

Figure 36-5. SD Memory Card Bus Topology

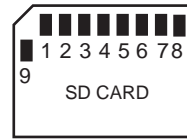

The SD Memory Card bus includes the signals listed in [Table 36-5](#).

Table 36-5. SD Memory Card Bus Signals

Pin Number	Name	Type ⁽¹⁾	Description	HSMCI Pin Name ⁽²⁾ (Slot z)
1	CD/DAT[3]	I/O/PP	Card detect/ Data line Bit 3	MCDz3
2	CMD	PP	Command/response	MCCDz
3	VSS1	S	Supply voltage ground	VSS
4	VDD	S	Supply voltage	VDD
5	CLK	I/O	Clock	MCCK
6	VSS2	S	Supply voltage ground	VSS
7	DAT[0]	I/O/PP	Data line Bit 0	MCDz0
8	DAT[1]	I/O/PP	Data line Bit 1 or Interrupt	MCDz1
9	DAT[2]	I/O/PP	Data line Bit 2	MCDz2

- Notes:
1. I: input, O: output, PP: Push Pull, OD: Open Drain.
 2. When several HSMCI (x HSMCI) are embedded in a product, MCCK refers to HSMCIx_CK, MCCDA to HSMCIx_CDA, MCDAY to HSMCIx_DAY.

Figure 36-6. SD Card Bus Connections with One Slot

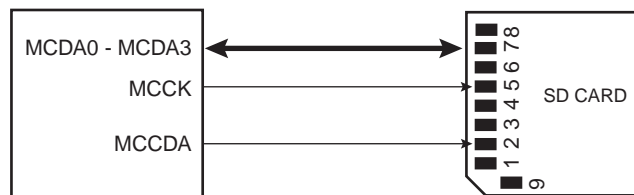

Note: When several HSMCI (x HSMCI) are embedded in a product, MCCK refers to HSMCIx_CK, MCCDA to HSMCIx_CDA, MCDAY to HSMCIx_DAY.

When the HSMCI is configured to operate with SD memory cards, the width of the data bus can be selected in the HSMCI_SDCR register. Clearing the SDCBUS bit in this register means that the width is one bit; setting it means that the width is four bits. In the case of High Speed Multi-Media cards, only the data line 0 is used. The other data lines can be used as independent PIOs.

36.8 High Speed MultiMediaCard Operations

After a power-on reset, the cards are initialized by a special message-based High Speed MultiMediaCard bus protocol. Each message is represented by one of the following tokens:

- **Command:** A command is a token that starts an operation. A command is sent from the host either to a single card (addressed command) or to all connected cards (broadcast command). A command is transferred serially on the CMD line.
- **Response:** A response is a token which is sent from an addressed card or (synchronously) from all connected cards to the host as an answer to a previously received command. A response is transferred serially on the CMD line.
- **Data:** Data can be transferred from the card to the host or vice versa. Data is transferred via the data line.

Card addressing is implemented using a session address assigned during the initialization phase by the bus controller to all currently connected cards. Their unique CID number identifies individual cards.

The structure of commands, responses and data blocks is described in the High Speed MultiMediaCard System Specification. See also [Table 36-6 on page 866](#).

High Speed MultiMediaCard bus data transfers are composed of these tokens.

There are different types of operations. Addressed operations always contain a command and a response token. In addition, some operations have a data token; the others transfer their information directly within the command or response structure. In this case, no data token is present in an operation. The bits on the DAT and the CMD lines are transferred synchronous to the clock HSMCI Clock.

Two types of data transfer commands are defined:

- **Sequential commands:** These commands initiate a continuous data stream. They are terminated only when a stop command follows on the CMD line. This mode reduces the command overhead to an absolute minimum.
- **Block-oriented commands:** These commands send a data block succeeded by CRC bits.

Both read and write operations allow either single or multiple block transmission. A multiple block transmission is terminated when a stop command follows on the CMD line similarly to the sequential read or when a multiple block transmission has a pre-defined block count (See [“Data Transfer Operation” on page 868](#).)

The HSMCI provides a set of registers to perform the entire range of High Speed MultiMedia Card operations.

36.8.1 Command - Response Operation

After reset, the HSMCI is disabled and becomes valid after setting the MCIEN bit in the HSMCI_CR Control Register.

The PWSEN bit saves power by dividing the HSMCI clock by $2^{PWSDIV} + 1$ when the bus is inactive.

The two bits, RDPROOF and WRPROOF in the HSMCI Mode Register (HSMCI_MR) allow stopping the HSMCI Clock during read or write access if the internal FIFO is full. This will guarantee data integrity, not bandwidth.

All the timings for High Speed MultiMedia Card are defined in the High Speed MultiMediaCard System Specification.

The two bus modes (open drain and push/pull) needed to process all the operations are defined in the HSMCI command register. The HSMCI_CMDR allows a command to be carried out.

For example, to perform an ALL_SEND_CID command:

CMD	Host Command					N _{ID} Cycles					CID		
	S	T	Content	CRC	E	Z	*****	Z	S	T	Content	Z	Z

The command ALL_SEND_CID and the fields and values for the HSMCI_CMDR Control Register are described in [Table 36-6](#) and [Table 36-7](#).

Table 36-6. ALL_SEND_CID Command Description

CMD Index	Type	Argument	Resp	Abbreviation	Command Description
CMD2	bcr ⁽¹⁾	[31:0] stuff bits	R2	ALL_SEND_CID	Asks all cards to send their CID numbers on the CMD line

Note: 1. bcr means broadcast command with response.

Table 36-7. Fields and Values for HSMCI_CMDR Command Register

Field	Value
CMDNB (command number)	2 (CMD2)
RSPTYP (response type)	2 (R2: 136 bits response)
SPCMD (special command)	0 (not a special command)
OPCMD (open drain command)	1
MAXLAT (max latency for command to response)	0 (NID cycles ==> 5 cycles)
TRCMD (transfer command)	0 (No transfer)
TRDIR (transfer direction)	X (available only in transfer command)
TRTYP (transfer type)	X (available only in transfer command)
IOSPCMD (SDIO special command)	0 (not a special command)

The HSMCI_ARGR contains the argument field of the command.

To send a command, the user must perform the following steps:

- Fill the argument register (HSMCI_ARGR) with the command argument.
- Set the command register (HSMCI_CMDR) (see [Table 36-7](#)).

The command is sent immediately after writing the command register.

While the card maintains a busy indication (at the end of a STOP_TRANSMISSION command CMD12, for example), a new command shall not be sent. The NOTBUSY flag in the status register (HSMCI_SR) is asserted when the card releases the busy indication.

If the command requires a response, it can be read in the HSMCI response register (HSMCI_RSPR). The response size can be from 48 bits up to 136 bits depending on the command. The HSMCI embeds an error detection to prevent any corrupted data during the transfer.

The following flowchart shows how to send a command to the card and read the response if needed. In this example, the status register bits are polled but setting the appropriate bits in the interrupt enable register (HSMCI_IER) allows using an interrupt method.

Figure 36-7. Command/Response Functional Flow Diagram

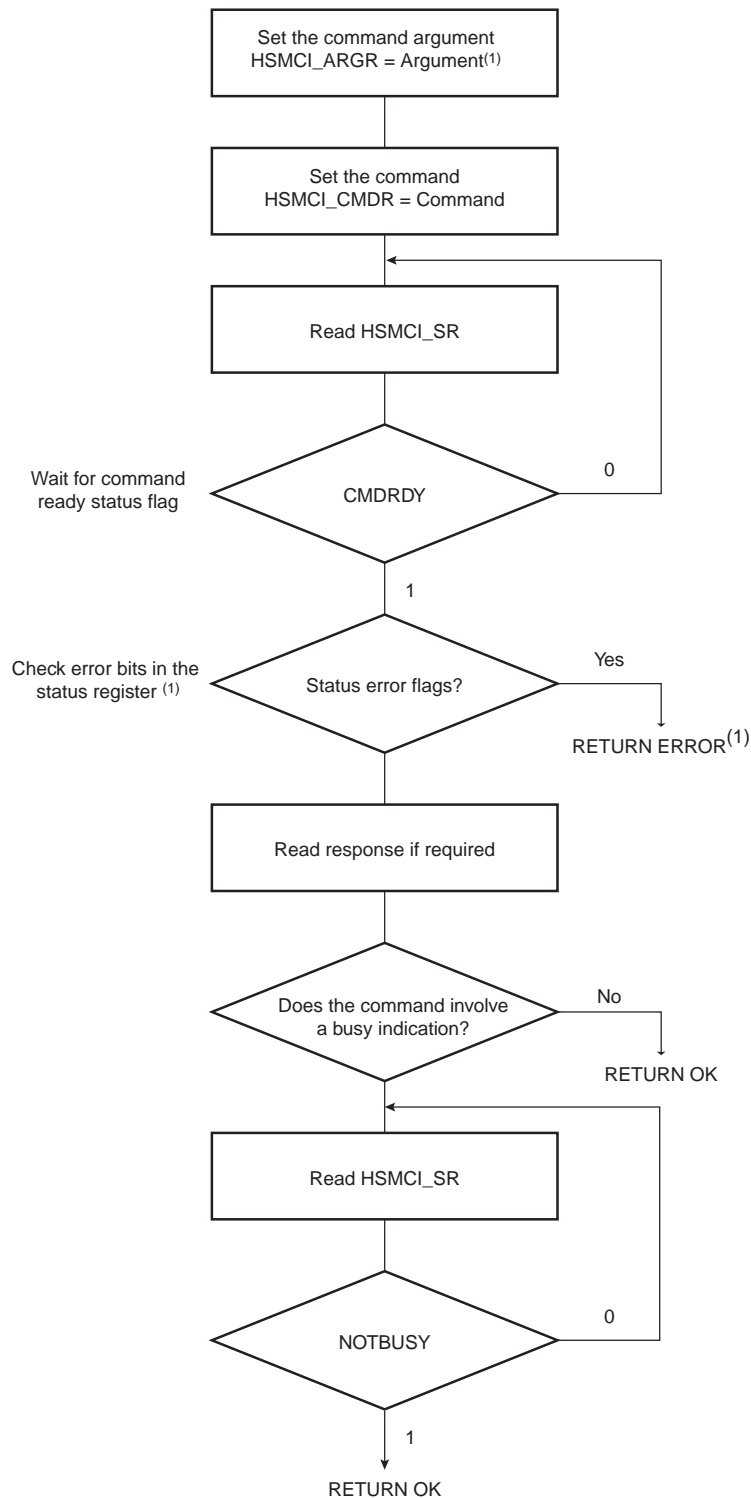

Note: 1. If the command is SEND_OP_COND, the CRC error flag is always present (refer to R3 response in the High Speed MultiMedia Card specification).

36.8.2 Data Transfer Operation

The High Speed MultiMedia Card allows several read/write operations (single block, multiple blocks, stream, etc.). These kinds of transfer can be selected setting the Transfer Type (TRTYP) field in the HSMCI Command Register (HSMCI_CMDR).

These operations can be done using the features of the Peripheral DMA Controller (PDC). If the PDCMODE bit is set in HSMCI_MR, then all reads and writes use the PDC facilities.

In all cases, the block length (BLKLEN field) must be defined either in the mode register HSMCI_MR, or in the Block Register HSMCI_BLKCR. This field determines the size of the data block.

Consequent to MMC Specification 3.1, two types of multiple block read (or write) transactions are defined (the host can use either one at any time):

- Open-ended/Infinite Multiple block read (or write):
The number of blocks for the read (or write) multiple block operation is not defined. The card will continuously transfer (or program) data blocks until a stop transmission command is received.
- Multiple block read (or write) with pre-defined block count (since version 3.1 and higher):
The card will transfer (or program) the requested number of data blocks and terminate the transaction. The stop command is not required at the end of this type of multiple block read (or write), unless terminated with an error. In order to start a multiple block read (or write) with pre-defined block count, the host must correctly program the HSMCI Block Register (HSMCI_BLKCR). Otherwise the card will start an open-ended multiple block read. The BCNT field of the Block Register defines the number of blocks to transfer (from 1 to 65535 blocks). Programming the value 0 in the BCNT field corresponds to an infinite block transfer.

36.8.3 Read Operation

The following flowchart shows how to read a single block with or without use of PDC facilities. In this example (see [Figure 36-8](#)), a polling method is used to wait for the end of read. Similarly, the user can configure the interrupt enable register (HSMCI_IER) to trigger an interrupt at the end of read.

Figure 36-8. Read Functional Flow Diagram

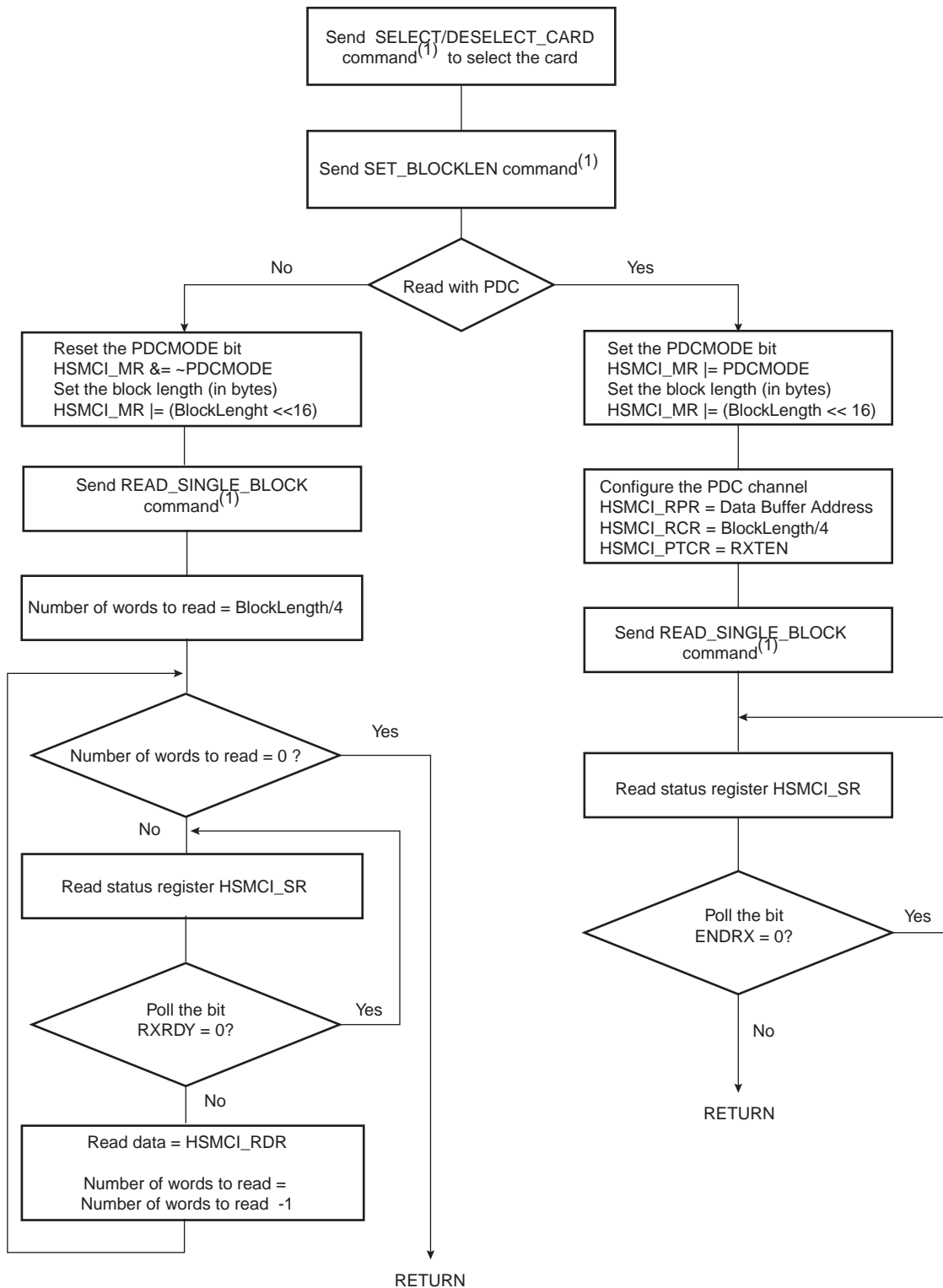

Note: 1. It is assumed that this command has been correctly sent (see [Figure 36-7](#)).

36.8.4 Write Operation

In write operation, the HSMCI Mode Register (HSMCI_MR) is used to define the padding value when writing non-multiple block size. If the bit PDCPADV is 0, then 0x00 value is used when padding data, otherwise 0xFF is used.

If set, the bit PDCMODE enables PDC transfer.

The following flowchart ([Figure 36-9](#)) shows how to write a single block with or without use of PDC facilities. Polling or interrupt method can be used to wait for the end of write according to the contents of the Interrupt Mask Register (HSMCI_IMR).

Figure 36-9. Write Functional Flow Diagram

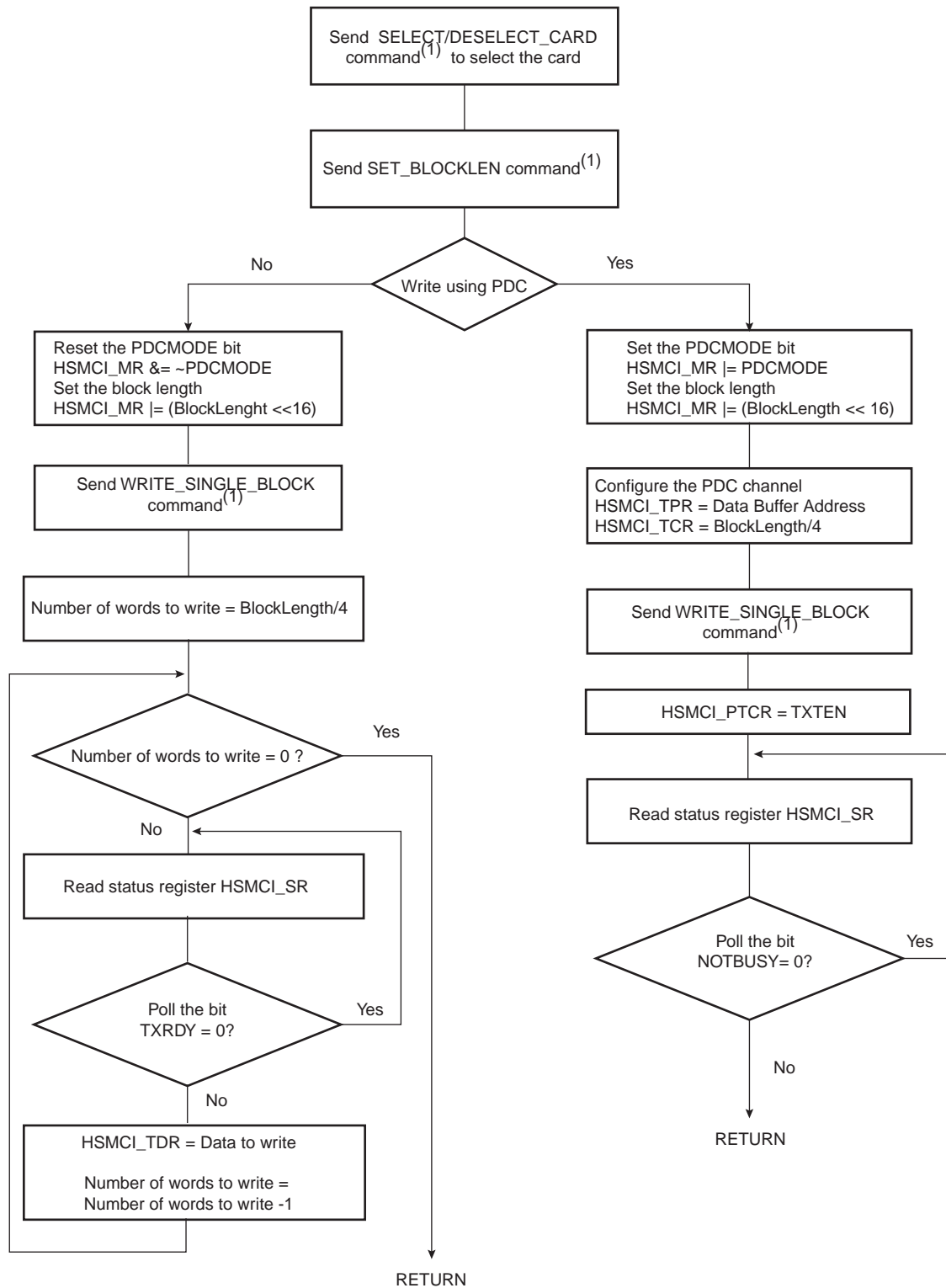

Note: 1. It is assumed that this command has been correctly sent (see Figure 36-7).

The following flowchart (Figure 36-10) shows how to manage a multiple write block transfer with the PDC. Polling or interrupt method can be used to wait for the end of write according to the contents of the Interrupt Mask Register (HSMCI_IMR).

Figure 36-10. Multiple Write Functional Flow Diagram

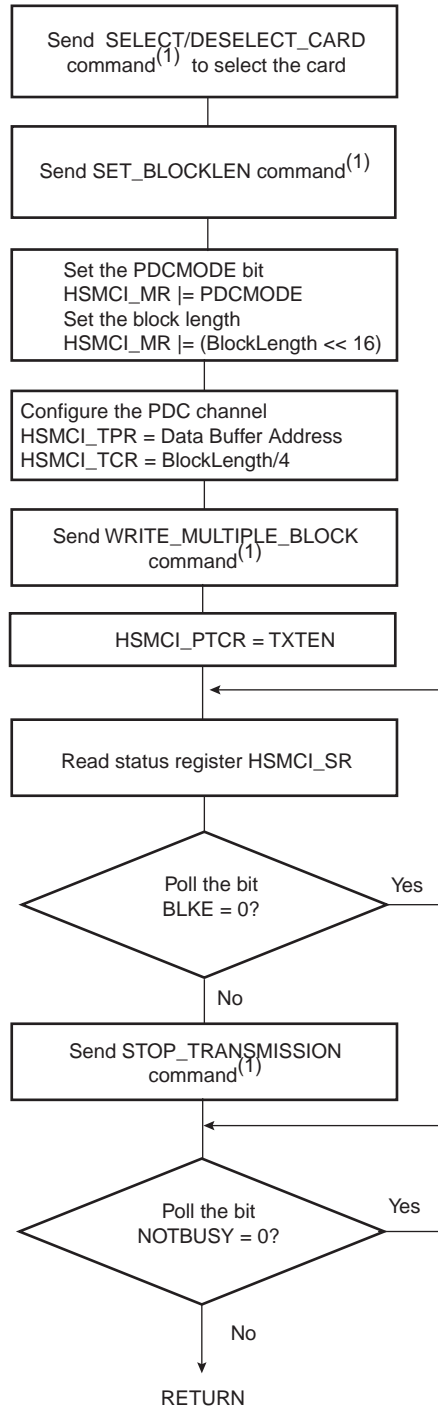

Note: 1. It is assumed that this command has been correctly sent (see Figure 36-7).

36.9 SD/SDIO Card Operation

The High Speed MultiMedia Card Interface allows processing of SD Memory (Secure Digital Memory Card) and SDIO (SD Input Output) Card commands.

SD/SDIO cards are based on the Multi Media Card (MMC) format, but are physically slightly thicker and feature higher data transfer rates, a lock switch on the side to prevent accidental overwriting and security features. The physical form factor, pin assignment and data transfer protocol are forward-compatible with the High Speed MultiMedia Card with some additions. SD slots can actually be used for more than flash memory cards. Devices that support SDIO can use small devices designed for the SD form factor, such as GPS receivers, Wi-Fi or Bluetooth adapters, modems, barcode readers, IrDA adapters, FM radio tuners, RFID readers, digital cameras and more.

SD/SDIO is covered by numerous patents and trademarks, and licensing is only available through the Secure Digital Card Association.

The SD/SDIO Card communication is based on a 9-pin interface (Clock, Command, 4 x Data and 3 x Power lines). The communication protocol is defined as a part of this specification. The main difference between the SD/SDIO Card and the High Speed MultiMedia Card is the initialization process.

The SD/SDIO Card Register (HSMCI_SDCR) allows selection of the Card Slot and the data bus width.

The SD/SDIO Card bus allows dynamic configuration of the number of data lines. After power up, by default, the SD/SDIO Card uses only DAT0 for data transfer. After initialization, the host can change the bus width (number of active data lines).

36.9.1 SDIO Data Transfer Type

SDIO cards may transfer data in either a multi-byte (1 to 512 bytes) or an optional block format (1 to 511 blocks), while the SD memory cards are fixed in the block transfer mode. The TRTYP field in the HSMCI Command Register (HSMCI_CMDR) allows to choose between SDIO Byte or SDIO Block transfer.

The number of bytes/blocks to transfer is set through the BCNT field in the HSMCI Block Register (HSMCI_BLKR). In SDIO Block mode, the field BLKLEN must be set to the data block size while this field is not used in SDIO Byte mode.

An SDIO Card can have multiple I/O or combined I/O and memory (called Combo Card). Within a multi-function SDIO or a Combo card, there are multiple devices (I/O and memory) that share access to the SD bus. In order to allow the sharing of access to the host among multiple devices, SDIO and combo cards can implement the optional concept of suspend/resume (Refer to the SDIO Specification for more details). To send a suspend or a resume command, the host must set the SDIO Special Command field (IOSPCMD) in the HSMCI Command Register.

36.9.2 SDIO Interrupts

Each function within an SDIO or Combo card may implement interrupts (Refer to the SDIO Specification for more details). In order to allow the SDIO card to interrupt the host, an interrupt function is added to a pin on the DAT[1] line to signal the card's interrupt to the host. An SDIO interrupt on each slot can be enabled through the HSMCI Interrupt Enable Register. The SDIO interrupt is sampled regardless of the currently selected slot.

36.10 CE-ATA Operation

CE-ATA maps the streamlined ATA command set onto the MMC interface. The ATA task file is mapped onto MMC register space.

CE-ATA utilizes five MMC commands:

- GO_IDLE_STATE (CMD0): used for hard reset.
- STOP_TRANSMISSION (CMD12): causes the ATA command currently executing to be aborted.
- FAST_IO (CMD39): Used for single register access to the ATA taskfile registers, 8 bit access only.
- RW_MULTIPLE_REGISTERS (CMD60): used to issue an ATA command or to access the control/status registers.
- RW_MULTIPLE_BLOCK (CMD61): used to transfer data for an ATA command.

CE-ATA utilizes the same MMC command sequences for initialization as traditional MMC devices.

36.10.1 Executing an ATA Polling Command

1. Issue READ_DMA_EXT with RW_MULTIPLE_REGISTER (CMD60) for 8kB of DATA.
2. Read the ATA status register until DRQ is set.
3. Issue RW_MULTIPLE_BLOCK (CMD61) to transfer DATA.
4. Read the ATA status register until DRQ && BSY are set to 0.

36.10.2 Executing an ATA Interrupt Command

1. Issue READ_DMA_EXT with RW_MULTIPLE_REGISTER (CMD60) for 8kB of DATA with nIEN field set to zero to enable the command completion signal in the device.
2. Issue RW_MULTIPLE_BLOCK (CMD61) to transfer DATA.
3. Wait for Completion Signal Received Interrupt.

36.10.3 Aborting an ATA Command

If the host needs to abort an ATA command prior to the completion signal it must send a special command to avoid potential collision on the command line. The SPCMD field of the HSMCI_CMDR must be set to 3 to issue the CE-ATA completion Signal Disable Command.

36.10.4 CE-ATA Error Recovery

Several methods of ATA command failure may occur, including:

- No response to an MMC command, such as RW_MULTIPLE_REGISTER (CMD60).
- CRC is invalid for an MMC command or response.
- CRC16 is invalid for an MMC data packet.
- ATA Status register reflects an error by setting the ERR bit to one.
- The command completion signal does not arrive within a host specified time out period.

Error conditions are expected to happen infrequently. Thus, a robust error recovery mechanism may be used for each error event. The recommended error recovery procedure after a timeout is:

- Issue the command completion signal disable if nIEN was cleared to zero and the RW_MULTIPLE_BLOCK (CMD61) response has been received.

- Issue STOP_TRANSMISSION (CMD12) and successfully receive the R1 response.
- Issue a software reset to the CE-ATA device using FAST_IO (CMD39).

If STOP_TRANSMISSION (CMD12) is successful, then the device is again ready for ATA commands. However, if the error recovery procedure does not work as expected or there is another timeout, the next step is to issue GO_IDLE_STATE (CMD0) to the device. GO_IDLE_STATE (CMD0) is a hard reset to the device and completely resets all device states.

Note that after issuing GO_IDLE_STATE (CMD0), all device initialization needs to be completed again. If the CE-ATA device completes all MMC commands correctly but fails the ATA command with the ERR bit set in the ATA Status register, no error recovery action is required. The ATA command itself failed implying that the device could not complete the action requested, however, there was no communication or protocol failure. After the device signals an error by setting the ERR bit to one in the ATA Status register, the host may attempt to retry the command.

36.11 HSMCI Boot Operation Mode

In boot operation mode, the processor can read boot data from the slave (MMC device) by keeping the CMD line low after power-on before issuing CMD1. The data can be read from either the boot area or user area, depending on register setting. As it is not possible to boot directly on SD-CARD, a preliminary boot code must be stored in internal Flash.

36.11.1 Boot Procedure, Processor Mode

1. Configure the HSMCI data bus width programming SDCBUS Field in the HSMCI_SDCR register. The BOOT_BUS_WIDTH field located in the device Extended CSD register must be set accordingly.
2. Set the byte count to 512 bytes and the block count to the desired number of blocks, writing BLKLEN and BCNT fields of the HSMCI_BLKCR Register.
3. Issue the Boot Operation Request command by writing to the HSMCI_CMDR register with SPCMD field set to BOOTREQ, TRDIR set to READ and TRCMD set to “start data transfer”.
4. The BOOT_ACK field located in the HSMCI_CMDR register must be set to one, if the BOOT_ACK field of the MMC device located in the Extended CSD register is set to one.
5. Host processor can copy boot data sequentially as soon as the RXRDY flag is asserted.
6. When Data transfer is completed, host processor shall terminate the boot stream by writing the HSMCI_CMDR register with SPCMD field set to BOOTEND.

36.12 HSMCI Transfer Done Timings

36.12.1 Definition

The XFRDONE flag in the HSMCI_SR indicates exactly when the read or write sequence is finished.

36.12.2 Read Access

During a read access, the XFRDONE flag behaves as shown in [Figure 36-11](#).

Figure 36-11. XFRDONE During a Read Access

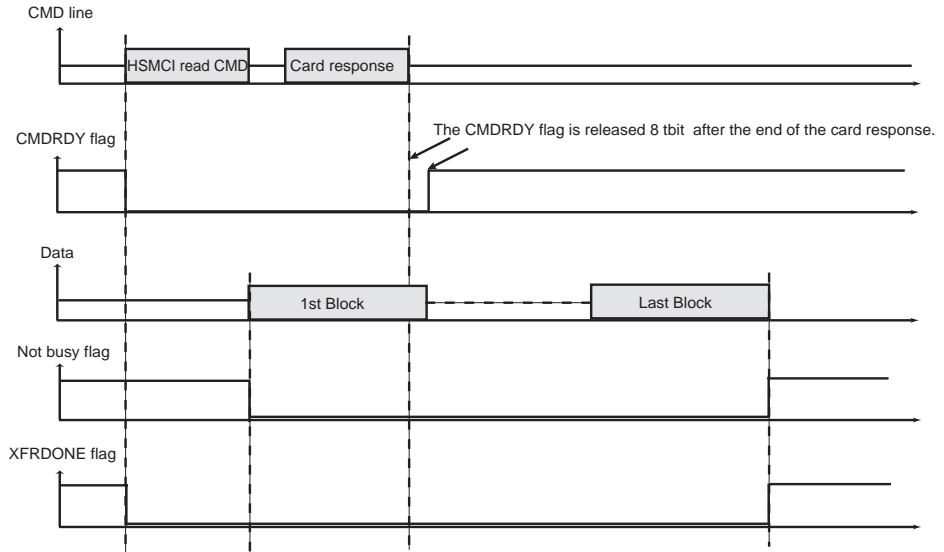

36.12.3 Write Access

During a write access, the XFRDONE flag behaves as shown in [Figure 36-12](#).

Figure 36-12. XFRDONE During a Write Access

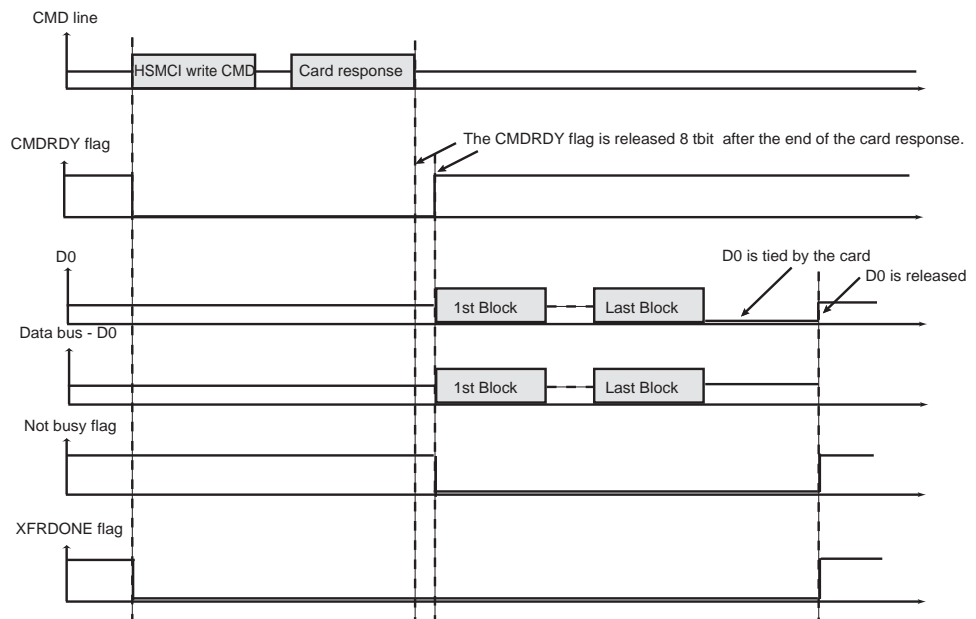

36.13 Write Protection Registers

To prevent any single software error that may corrupt HSMCI behavior, the entire HSMCI address space from address offset 0x000 to 0x00FC can be write-protected by setting the WPEN bit in the “[HSMCI Write Protect Mode Register](#)” (HSMCI_WPMR).

If a write access to anywhere in the HSMCI address space from address offset 0x000 to 0x00FC is detected, then the WPVS flag in the HSMCI Write Protect Status Register (HSMCI_WPSR) is set and the field WPVSR indicates in which register the write access has been attempted.

The WPVS flag is reset by writing the HSMCI Write Protect Mode Register (HSMCI_WPMR) with the appropriate access key, WPKEY.

The protected registers are:

- “[HSMCI Mode Register](#)”
- “[HSMCI Data Timeout Register](#)”
- “[HSMCI SDCard/SDIO Register](#)”
- “[HSMCI Completion Signal Timeout Register](#)”
- “[HSMCI Configuration Register](#)”

36.14 High Speed Multimedia Card Interface (HSMCI) User Interface

Table 36-8. Register Mapping

Offset	Register	Name	Access	Reset
0x00	Control Register	HSMCI_CR	Write	–
0x04	Mode Register	HSMCI_MR	Read-write	0x0
0x08	Data Timeout Register	HSMCI_DTOR	Read-write	0x0
0x0C	SD/SDIO Card Register	HSMCI_SDCR	Read-write	0x0
0x10	Argument Register	HSMCI_ARGR	Read-write	0x0
0x14	Command Register	HSMCI_CMDR	Write	–
0x18	Block Register	HSMCI_BLKR	Read-write	0x0
0x1C	Completion Signal Timeout Register	HSMCI_CSTOR	Read-write	0x0
0x20	Response Register ⁽¹⁾	HSMCI_RSPR	Read	0x0
0x24	Response Register ⁽¹⁾	HSMCI_RSPR	Read	0x0
0x28	Response Register ⁽¹⁾	HSMCI_RSPR	Read	0x0
0x2C	Response Register ⁽¹⁾	HSMCI_RSPR	Read	0x0
0x30	Receive Data Register	HSMCI_RDR	Read	0x0
0x34	Transmit Data Register	HSMCI_TDR	Write	–
0x38 - 0x3C	Reserved	–	–	–
0x40	Status Register	HSMCI_SR	Read	0xC0E5
0x44	Interrupt Enable Register	HSMCI_IER	Write	–
0x48	Interrupt Disable Register	HSMCI_IDR	Write	–
0x4C	Interrupt Mask Register	HSMCI_IMR	Read	0x0
0x50	Reserved	–	–	–
0x54	Configuration Register	HSMCI_CFG	Read-write	0x00
0x58-0xE0	Reserved	–	–	–
0xE4	Write Protection Mode Register	HSMCI_WPMR	Read-write	–
0xE8	Write Protection Status Register	HSMCI_WPSR	Read-only	–
0xEC - 0xFC	Reserved	–	–	–
0x100-0x1FC	Reserved	–	–	–
0x200	FIFO Memory Aperture0	HSMCI_FIFO0	Read-write	0x0
...
0x5FC	FIFO Memory Aperture255	HSMCI_FIFO255	Read-write	0x0

Note: 1. The response register can be read by N accesses at the same HSMCI_RSPR or at consecutive addresses (0x20 to 0x2C). N depends on the size of the response.

36.14.1 HSMCI Control Register

Name: HSMCI_CR
Address: 0x40000000
Access: Write-only

31	30	29	28	27	26	25	24
–	–	–	–	–	–	–	–
23	22	21	20	19	18	17	16
–	–	–	–	–	–	–	–
15	14	13	12	11	10	9	8
–	–	–	–	–	–	–	–
7	6	5	4	3	2	1	0
SWRST	–	–	–	PWSDIS	PWSEN	MCIDIS	MCIEN

- **MCIEN: Multi-Media Interface Enable**

0 = No effect.

1 = Enables the Multi-Media Interface if MCDIS is 0.

- **MCIDIS: Multi-Media Interface Disable**

0 = No effect.

1 = Disables the Multi-Media Interface.

- **PWSEN: Power Save Mode Enable**

0 = No effect.

1 = Enables the Power Saving Mode if PWSDIS is 0.

Warning: Before enabling this mode, the user must set a value different from 0 in the PWSDIV field (Mode Register, HSMCI_MR).

- **PWSDIS: Power Save Mode Disable**

0 = No effect.

1 = Disables the Power Saving Mode.

- **SWRST: Software Reset**

0 = No effect.

1 = Resets the HSMCI. A software triggered hardware reset of the HSMCI interface is performed.

36.14.2 HSMCI Mode Register

Name: HSMCI_MR
Address: 0x40000004
Access: Read-write

31	30	29	28	27	26	25	24
–	–	–	–	–	–	–	–
23	22	21	20	19	18	17	16
–	–	–	–	–	–	–	–
15	14	13	12	11	10	9	8
PDCMODE	PADV	FBYTE	WRPROOF	RDPROOF	PWSDIV		
7	6	5	4	3	2	1	0
CLKDIV							

This register can only be written if the WPEN bit is cleared in “HSMCI Write Protect Mode Register” on page 903.

- **CLKDIV: Clock Divider**

High Speed MultiMedia Card Interface clock (MCK) is Master Clock (MCK) divided by (2*(CLKDIV+1)).

- **PWSDIV: Power Saving Divider**

High Speed MultiMedia Card Interface clock is divided by $2^{(PWSDIV)} + 1$ when entering Power Saving Mode.

Warning: This value must be different from 0 before enabling the Power Save Mode in the HSMCI_CR (HSMCI_PWSEN bit).

- **RDPROOF Read Proof Enable**

Enabling Read Proof allows to stop the HSMCI Clock during read access if the internal FIFO is full. This will guarantee data integrity, not bandwidth.

0 = Disables Read Proof.

1 = Enables Read Proof.

- **WRPROOF Write Proof Enable**

Enabling Write Proof allows to stop the HSMCI Clock during write access if the internal FIFO is full. This will guarantee data integrity, not bandwidth.

0 = Disables Write Proof.

1 = Enables Write Proof.

- **FBYTE: Force Byte Transfer**

Enabling Force Byte Transfer allow byte transfers, so that transfer of blocks with a size different from modulo 4 can be supported.

Warning: BLKLEN value depends on FBYTE.

0 = Disables Force Byte Transfer.

1 = Enables Force Byte Transfer.

- **PADV: Padding Value**

0 = 0x00 value is used when padding data in write transfer.

1 = 0xFF value is used when padding data in write transfer.

PADV may be only in manual transfer.

- **PDCMODE: PDC-oriented Mode**

0 = Disables PDC transfer

1 = Enables PDC transfer. In this case, UNRE and OVRE flags in the MCI Mode Register (MCI_SR) are deactivated after the PDC transfer has been completed.

36.14.3 HSMCI Data Timeout Register

Name: HSMCI_DTOR

Address: 0x40000008

Access: Read-write

31	30	29	28	27	26	25	24
–	–	–	–	–	–	–	–
23	22	21	20	19	18	17	16
–	–	–	–	–	–	–	–
15	14	13	12	11	10	9	8
–	–	–	–	–	–	–	–
7	6	5	4	3	2	1	0
–	DTOMUL			DTOCYC			

This register can only be written if the WPEN bit is cleared in “HSMCI Write Protect Mode Register” on page 903.

- **DTOCYC: Data Timeout Cycle Number**

These fields determine the maximum number of Master Clock cycles that the HSMCI waits between two data block transfers. It equals (DTCYC x Multiplier).

- **DTOMUL: Data Timeout Multiplier**

Multiplier is defined by DTOMUL as shown in the following table:

Value	Name	Description
0	1	DTCYC
1	16	DTCYC x 16
2	128	DTCYC x 128
3	256	DTCYC x 256
4	1024	DTCYC x 1024
5	4096	DTCYC x 4096
6	65536	DTCYC x 65536
7	1048576	DTCYC x 1048576

If the data time-out set by DTCYC and DTOMUL has been exceeded, the Data Time-out Error flag (DTCOE) in the HSMCI Status Register (HSMCI_SR) rises.

36.14.4 HSMCI SDCard/SDIO Register

Name: HSMCI_SDCR

Address: 0x4000000C

Access: Read-write

31	30	29	28	27	26	25	24
–	–	–	–	–	–	–	–
23	22	21	20	19	18	17	16
–	–	–	–	–	–	–	–
15	14	13	12	11	10	9	8
–	–	–	–	–	–	–	–
7	6	5	4	3	2	1	0
SDCBUS		–	–	–	–	SDCSEL	

This register can only be written if the WPEN bit is cleared in “[HSMCI Write Protect Mode Register](#)” on page 903.

- **SDCSEL: SDCard/SDIO Slot**

Value	Name	Description
0	SLOTA	Slot A is selected.
1	SLOTB	–
2	SLOTC	–
3	SLOTD	–

- **SDCBUS: SDCard/SDIO Bus Width**

Value	Name	Description
0	1	1 bit
1	–	Reserved
2	4	4 bit
3	8	8 bit



36.14.5 HSMCI Argument Register

Name: HSMCI_ARGR

Address: 0x40000010

Access: Read-write

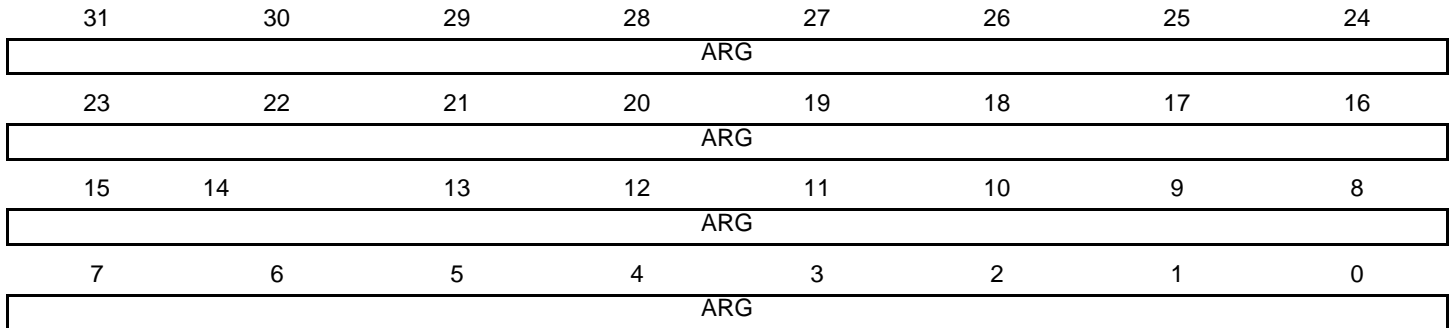

- **ARG: Command Argument**



36.14.6 HSMCI Command Register

Name: HSMCI_CMDR

Address: 0x40000014

Access: Write-only

31	30	29	28	27	26	25	24
–	–	–	–	BOOT_ACK	ATACS	IOSPCMD	
23	22	21	20	19	18	17	16
–	–	TRTYP			TRDIR	TRCMD	
15	14	13	12	11	10	9	8
–	–	–	MAXLAT	OPDCMD	SPCMD		
7	6	5	4	3	2	1	0
RSPTYP			CMDNB				

This register is write-protected while CMDRDY is 0 in HSMCI_SR. If an Interrupt command is sent, this register is only writable by an interrupt response (field SPCMD). This means that the current command execution cannot be interrupted or modified.

- **CMDNB: Command Number**

This is the command index.

- **RSPTYP: Response Type**

Value	Name	Description
0	NORESP	No response.
1	48_BIT	48-bit response.
2	136_BIT	136-bit response.
3	R1B	R1b response type

- **SPCMD: Special Command**

Value	Name	Description
0	STD	Not a special CMD.
1	INIT	Initialization CMD: 74 clock cycles for initialization sequence.
2	SYNC	Synchronized CMD: Wait for the end of the current data block transfer before sending the pending command.
3	CE_ATA	CE-ATA Completion Signal disable Command. The host cancels the ability for the device to return a command completion signal on the command line.
4	IT_CMD	Interrupt command: Corresponds to the Interrupt Mode (CMD40).

Value	Name	Description
5	IT_RESP	Interrupt response: Corresponds to the Interrupt Mode (CMD40).
6	BOR	Boot Operation Request. Start a boot operation mode, the host processor can read boot data from the MMC device directly.
7	EBO	End Boot Operation. This command allows the host processor to terminate the boot operation mode.

- **OPDCMD: Open Drain Command**

0 (PUSHPULL) = Push pull command.

1 (OPENDRAIN) = Open drain command.

- **MAXLAT: Max Latency for Command to Response**

0 (5) = 5-cycle max latency.

1 (64) = 64-cycle max latency.

- **TRCMD: Transfer Command**

Value	Name	Description
0	NO_DATA	No data transfer
1	START_DATA	Start data transfer
2	STOP_DATA	Stop data transfer
3	–	Reserved

- **TRDIR: Transfer Direction**

0 (WRITE) = Write.

1 (READ) = Read.

- **TRTYP: Transfer Type**

Value	Name	Description
0	SINGLE	MMC/SDCard Single Block
1	MULTIPLE	MMC/SDCard Multiple Block
2	STREAM	MMC Stream
4	BYTE	SDIO Byte
5	BLOCK	SDIO Block

- **IOSPCMD: SDIO Special Command**

Value	Name	Description
0	STD	Not an SDIO Special Command
1	SUSPEND	SDIO Suspend Command
2	RESUME	SDIO Resume Command

- **ATACS: ATA with Command Completion Signal**

0 (NORMAL) = Normal operation mode.

1 (COMPLETION) = This bit indicates that a completion signal is expected within a programmed amount of time (HSMCI_CSTOR).

- **BOOT_ACK: Boot Operation Acknowledge.**

The master can choose to receive the boot acknowledge from the slave when a Boot Request command is issued. When set to one this field indicates that a Boot acknowledge is expected within a programmable amount of time defined with DTOMUL and DTOCYC fields located in the HSMCI_DTOR register. If the acknowledge pattern is not received then an acknowledge timeout error is raised. If the acknowledge pattern is corrupted then an acknowledge pattern error is set.



36.14.7 HSMCI Block Register

Name: HSMCI_BLK R

Address: 0x40000018

Access: Read-write

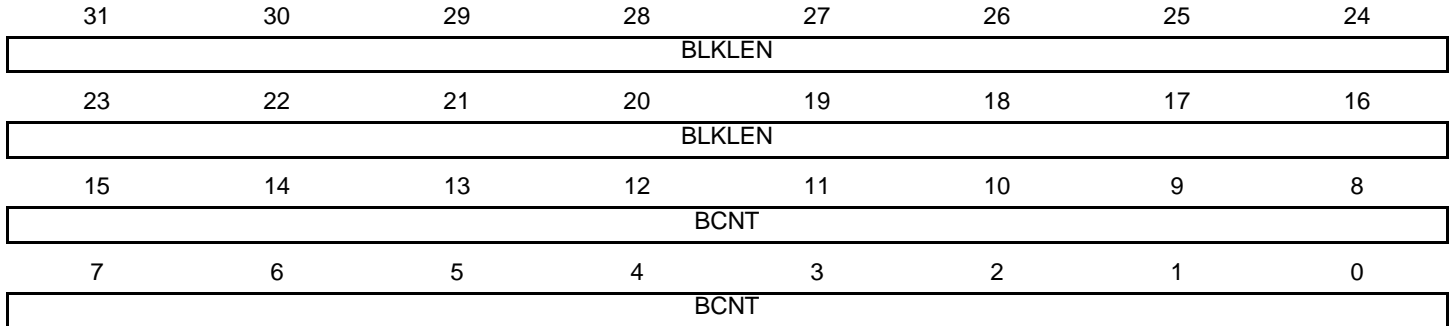

• **BCNT: MMC/SDIO Block Count - SDIO Byte Count**

This field determines the number of data byte(s) or block(s) to transfer.

The transfer data type and the authorized values for BCNT field are determined by the TRTYP field in the HSMCI Command Register (HSMCI_CMDR):

Value	Name	Description
0	MULTIPLE	MMC/SDCARD Multiple Block From 1 to 65635: Value 0 corresponds to an infinite block transfer.
4	BYTE	SDIO Byte From 1 to 512 bytes: Value 0 corresponds to a 512-byte transfer. Values from 0x200 to 0xFFFF are forbidden.
5	BLOCK	SDIO Block From 1 to 511 blocks: Value 0 corresponds to an infinite block transfer. Values from 0x200 to 0xFFFF are forbidden.

Warning: In SDIO Byte and Block modes, writing to the 7 last bits of BCNT field is forbidden and may lead to unpredictable results.

• **BLKLEN: Data Block Length**

This field determines the size of the data block.

This field is also accessible in the HSMCI Mode Register (HSMCI_MR).

Bits 16 and 17 must be set to 0 if FBYTE is disabled.

Note: In SDIO Byte mode, BLKLEN field is not used.

36.14.8 HSMCI Completion Signal Timeout Register

Name: HSMCI_CSTOR

Address: 0x4000001C

Access: Read-write

31	30	29	28	27	26	25	24
–	–	–	–	–	–	–	–
23	22	21	20	19	18	17	16
–	–	–	–	–	–	–	–
15	14	13	12	11	10	9	8
–	–	–	–	–	–	–	–
7	6	5	4	3	2	1	0
–	CSTOMUL			CSTOCYC			

This register can only be written if the WPEN bit is cleared in “[HSMCI Write Protect Mode Register](#)” on page 903.

- **CSTOCYC: Completion Signal Timeout Cycle Number**

These fields determine the maximum number of Master Clock cycles that the HSMCI waits between two data block transfers. Its value is calculated by (CSTOCYC x Multiplier).

- **CSTOMUL: Completion Signal Timeout Multiplier**

These fields determine the maximum number of Master Clock cycles that the HSMCI waits between two data block transfers. Its value is calculated by (CSTOCYC x Multiplier).

These fields determine the maximum number of Master Clock cycles that the HSMCI waits between the end of the data transfer and the assertion of the completion signal. The data transfer comprises data phase and the optional busy phase. If a non-DATA ATA command is issued, the HSMCI starts waiting immediately after the end of the response until the completion signal.

Multiplier is defined by CSTOMUL as shown in the following table:

Value	Name	Description
0	1	CSTOCYC x 1
1	16	CSTOCYC x 16
2	128	CSTOCYC x 128
3	256	CSTOCYC x 256
4	1024	CSTOCYC x 1024
5	4096	CSTOCYC x 4096
6	65536	CSTOCYC x 65536
7	1048576	CSTOCYC x 1048576

If the data time-out set by CSTOCYC and CSTOMUL has been exceeded, the Completion Signal Time-out Error flag (CSTOE) in the HSMCI Status Register (HSMCI_SR) rises.

36.14.9 HSMCI Response Register

Name: HSMCI_RSPR

Address: 0x40000020

Access: Read-only

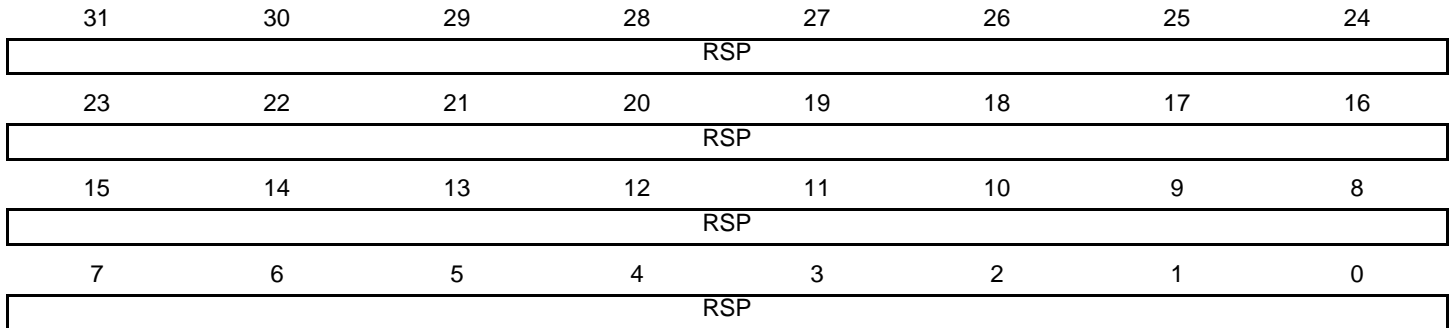

- **RSP: Response**

Note: The response register can be read by N accesses at the same HSMCI_RSPR or at consecutive addresses (0x20 to 0x2C). N depends on the size of the response.

36.14.10 HSMCI Receive Data Register

Name: HSMCI_RDR

Address: 0x40000030

Access: Read-only

31	30	29	28	27	26	25	24
DATA							
23	22	21	20	19	18	17	16
DATA							
15	14	13	12	11	10	9	8
DATA							
7	6	5	4	3	2	1	0
DATA							

- **DATA: Data to Read**

36.14.11 HSMCI Transmit Data Register

Name: HSMCI_TDR

Address: 0x40000034

Access: Write-only

31	30	29	28	27	26	25	24
DATA							
23	22	21	20	19	18	17	16
DATA							
15	14	13	12	11	10	9	8
DATA							
7	6	5	4	3	2	1	0
DATA							

- **DATA: Data to Write**

36.14.12 HSMCI Status Register

Name: HSMCI_SR
Address: 0x40000040
Access: Read-only

31	30	29	28	27	26	25	24
UNRE	OVRE	ACKRCVE	ACKRCV	XFRDONE	FIFOEMPTY	–	–
23	22	21	20	19	18	17	16
CSTOE	DTOE	DCRCE	RTOE	RENDE	RCRCE	RDIRE	RINDE
15	14	13	12	11	10	9	8
TXBUFE	RXBUFF	CSRCV	SDIOWAIT	–	–	–	SDIOIRQA
7	6	5	4	3	2	1	0
ENDTX	ENDRX	NOTBUSY	DTIP	BLKE	TXRDY	RXRDY	CMDRDY

- **CMDRDY: Command Ready**

0 = A command is in progress.

1 = The last command has been sent. Cleared when writing in the HSMCI_CMDR.

- **RXRDY: Receiver Ready**

0 = Data has not yet been received since the last read of HSMCI_RDR.

1 = Data has been received since the last read of HSMCI_RDR.

- **TXRDY: Transmit Ready**

0= The last data written in HSMCI_TDR has not yet been transferred in the Shift Register.

1= The last data written in HSMCI_TDR has been transferred in the Shift Register.

- **BLKE: Data Block Ended**

This flag must be used only for Write Operations.

0 = A data block transfer is not yet finished. Cleared when reading the HSMCI_SR.

1 = A data block transfer has ended, including the CRC16 Status transmission. the flag is set for each transmitted CRC Status.

Refer to the MMC or SD Specification for more details concerning the CRC Status.

- **DTIP: Data Transfer in Progress**

0 = No data transfer in progress.

1 = The current data transfer is still in progress, including CRC16 calculation. Cleared at the end of the CRC16 calculation.

- **NOTBUSY: HSMCI Not Busy**

This flag must be used only for Write Operations.

A block write operation uses a simple busy signalling of the write operation duration on the data (DAT0) line: during a data transfer block, if the card does not have a free data receive buffer, the card indicates this condition by pulling down the data line (DAT0) to LOW. The card stops pulling down the data line as soon as at least one receive buffer for the defined data transfer block length becomes free.

The NOTBUSY flag allows to deal with these different states.

0 = The HSMCI is not ready for new data transfer. Cleared at the end of the card response.

1 = The HSMCI is ready for new data transfer. Set when the busy state on the data line has ended. This corresponds to a free internal data receive buffer of the card.

Refer to the MMC or SD Specification for more details concerning the busy behavior.

For all the read operations, the NOTBUSY flag is cleared at the end of the host command.

For the Infinite Read Multiple Blocks, the NOTBUSY flag is set at the end of the STOP_TRANSMISSION host command (CMD12).

For the Single Block Reads, the NOTBUSY flag is set at the end of the data read block.

For the Multiple Block Reads with pre-defined block count, the NOTBUSY flag is set at the end of the last received data block.

- **ENDRX: End of RX Buffer**

0 = The Receive Counter Register has not reached 0 since the last write in HSMCI_RCR or HSMCI_RNCR.

1 = The Receive Counter Register has reached 0 since the last write in HSMCI_RCR or HSMCI_RNCR.

- **ENDTX: End of TX Buffer**

0 = The Transmit Counter Register has not reached 0 since the last write in HSMCI_TCR or HSMCI_TNCR.

1 = The Transmit Counter Register has reached 0 since the last write in HSMCI_TCR or HSMCI_TNCR.

Note: BLKE and NOTBUSY flags can be used to check that the data has been successfully transmitted on the data lines and not only transferred from the PDC to the HSMCI Controller.

- **SDIOIRQ: SDIO Interrupt for Slot A**

0 = No interrupt detected on SDIO Slot A.

1 = An SDIO Interrupt on Slot A occurred. Cleared when reading the HSMCI_SR.

- **SDIOWAIT: SDIO Read Wait Operation Status**

0 = Normal Bus operation.

1 = The data bus has entered IO wait state.

- **CSRCV: CE-ATA Completion Signal Received**

0 = No completion signal received since last status read operation.

1 = The device has issued a command completion signal on the command line. Cleared by reading in the HSMCI_SR register.

- **RXBUFF: RX Buffer Full**

0 = HSMCI_RCR or HSMCI_RNCR has a value other than 0.

1 = Both HSMCI_RCR and HSMCI_RNCR have a value of 0.

- **TXBUFE: TX Buffer Empty**

0 = HSMCI_TCR or HSMCI_TNCR has a value other than 0.

1 = Both HSMCI_TCR and HSMCI_TNCR have a value of 0.

Note: BLKE and NOTBUSY flags can be used to check that the data has been successfully transmitted on the data lines and not only transferred from the PDC to the HSMCI Controller.

- **RINDE: Response Index Error**

0 = No error.

1 = A mismatch is detected between the command index sent and the response index received. Cleared when writing in the HSMCI_CMDR.

- **RDIRE: Response Direction Error**

0 = No error.

1 = The direction bit from card to host in the response has not been detected.

- **RCRCE: Response CRC Error**

0 = No error.

1 = A CRC7 error has been detected in the response. Cleared when writing in the HSMCI_CMDR.

- **RENDE: Response End Bit Error**

0 = No error.

1 = The end bit of the response has not been detected. Cleared when writing in the HSMCI_CMDR.

- **RTOE: Response Time-out Error**

0 = No error.

1 = The response time-out set by MAXLAT in the HSMCI_CMDR has been exceeded. Cleared when writing in the HSMCI_CMDR.

- **DCRCE: Data CRC Error**

0 = No error.

1 = A CRC16 error has been detected in the last data block. Cleared by reading in the HSMCI_SR register.

- **DTOE: Data Time-out Error**

0 = No error.

1 = The data time-out set by DTOCYC and DTOMUL in HSMCI_DTOR has been exceeded. Cleared by reading in the HSMCI_SR register.

- **CSTOE: Completion Signal Time-out Error**

0 = No error.

1 = The completion signal time-out set by CSTOCYC and CSTOMUL in HSMCI_CSTOR has been exceeded. Cleared by reading in the HSMCI_SR register. Cleared by reading in the HSMCI_SR register.

- **FIFOEMPTY: FIFO empty flag**

0 = FIFO contains at least one byte.

1 = FIFO is empty.

- **XFRDONE: Transfer Done flag**

0 = A transfer is in progress.

1 = Command register is ready to operate and the data bus is in the idle state.

- **ACKRCV: Boot Operation Acknowledge Received**

0 = No Boot acknowledge received since the last read of the status register.

1 = A Boot acknowledge signal has been received. Cleared by reading the HSMCI_SR register.

- **ACKRCVE: Boot Operation Acknowledge Error**

0 = No error

1 = Corrupted Boot Acknowledge signal received.

- **OVRE: Overrun**

0 = No error.

1 = At least one 8-bit received data has been lost (not read). Cleared when sending a new data transfer command.

When FERRCTRL in HSMCI_CFG is set to 1, OVRE becomes reset after read.

- **UNRE: Underrun**

0 = No error.

1 = At least one 8-bit data has been sent without valid information (not written). Cleared when sending a new data transfer command or when setting FERRCTRL in HSMCI_CFG to 1.

When FERRCTRL in HSMCI_CFG is set to 1, UNRE becomes reset after read.



36.14.13 HSMCI Interrupt Enable Register

Name: HSMCI_IER

Address: 0x40000044

Access: Write-only

31	30	29	28	27	26	25	24
UNRE	OVRE	ACKRCVE	ACKRCV	XFRDONE	FIFOEMPTY	–	–
23	22	21	20	19	18	17	16
CSTOE	DTOE	DCRCE	RTOE	RENDE	RCRCE	RDIRE	RINDE
15	14	13	12	11	10	9	8
TXBUFE	RXBUFF	CSRCV	SDIOWAIT	–	–	–	SDIOIRQA
7	6	5	4	3	2	1	0
ENDTX	ENDRX	NOTBUSY	DTIP	BLKE	TXRDY	RXRDY	CMDRDY

- **CMDRDY: Command Ready Interrupt Enable**
- **RXRDY: Receiver Ready Interrupt Enable**
- **TXRDY: Transmit Ready Interrupt Enable**
- **BLKE: Data Block Ended Interrupt Enable**
- **DTIP: Data Transfer in Progress Interrupt Enable**
- **NOTBUSY: Data Not Busy Interrupt Enable**
- **ENDRX: End of Receive Buffer Interrupt Enable**
- **ENDTX: End of Transmit Buffer Interrupt Enable**
- **SDIOIRQA: SDIO Interrupt for Slot A Interrupt Enable**
- **SDIOIRQD: SDIO Interrupt for Slot D Interrupt Enable**
- **SDIOWAIT: SDIO Read Wait Operation Status Interrupt Enable**
- **CSRCV: Completion Signal Received Interrupt Enable**
- **RXBUFF: Receive Buffer Full Interrupt Enable**
- **TXBUFE: Transmit Buffer Empty Interrupt Enable**
- **RINDE: Response Index Error Interrupt Enable**
- **RDIRE: Response Direction Error Interrupt Enable**
- **RCRCE: Response CRC Error Interrupt Enable**
- **RENDE: Response End Bit Error Interrupt Enable**
- **RTOE: Response Time-out Error Interrupt Enable**

- **DCRCE: Data CRC Error Interrupt Enable**
- **DTOE: Data Time-out Error Interrupt Enable**
- **CSTOE: Completion Signal Timeout Error Interrupt Enable**
- **FIFOEMPTY: FIFO empty Interrupt enable**
- **XFRDONE: Transfer Done Interrupt enable**
- **ACKRCV: Boot Acknowledge Interrupt Enable**
- **ACKRCVE: Boot Acknowledge Error Interrupt Enable**
- **OVRE: Overrun Interrupt Enable**
- **UNRE: Underrun Interrupt Enable**

0 = No effect.

1 = Enables the corresponding interrupt.



36.14.14 HSMCI Interrupt Disable Register

Name: HSMCI_IDR

Address: 0x40000048

Access: Write-only

31	30	29	28	27	26	25	24
UNRE	OVRE	ACKRCVE	ACKRCV	XFRDONE	FIFOEMPTY	–	–
23	22	21	20	19	18	17	16
CSTOE	DTOE	DCRCE	RTOE	RENDE	RCRCE	RDIRE	RINDE
15	14	13	12	11	10	9	8
TXBUFE	RXBUFF	CSRCV	SDIOWAIT	–	–	–	SDIOIRQA
7	6	5	4	3	2	1	0
ENDTX	ENDRX	NOTBUSY	DTIP	BLKE	TXRDY	RXRDY	CMDRDY

- **CMDRDY: Command Ready Interrupt Disable**
- **RXRDY: Receiver Ready Interrupt Disable**
- **TXRDY: Transmit Ready Interrupt Disable**
- **BLKE: Data Block Ended Interrupt Disable**
- **DTIP: Data Transfer in Progress Interrupt Disable**
- **NOTBUSY: Data Not Busy Interrupt Disable**
- **ENDRX: End of Receive Buffer Interrupt Disable**
- **ENDTX: End of Transmit Buffer Interrupt Disable**
- **SDIOIRQA: SDIO Interrupt for Slot A Interrupt Disable**
- **SDIOWAIT: SDIO Read Wait Operation Status Interrupt Disable**
- **CSRCV: Completion Signal received interrupt Disable**
- **RXBUFF: Receive Buffer Full Interrupt Disable**
- **TXBUFE: Transmit Buffer Empty Interrupt Disable**
- **RINDE: Response Index Error Interrupt Disable**
- **RDIRE: Response Direction Error Interrupt Disable**
- **RCRCE: Response CRC Error Interrupt Disable**
- **RENDE: Response End Bit Error Interrupt Disable**
- **RTOE: Response Time-out Error Interrupt Disable**
- **DCRCE: Data CRC Error Interrupt Disable**

- **DTOE: Data Time-out Error Interrupt Disable**
- **CSTOE: Completion Signal Time out Error Interrupt Disable**
- **FIFOEMPTY: FIFO empty Interrupt Disable**
- **XFRDONE: Transfer Done Interrupt Disable**
- **ACKRCV: Boot Acknowledge Interrupt Disable**
- **ACKRCVE: Boot Acknowledge Error Interrupt Disable**
- **OVRE: Overrun Interrupt Disable**
- **UNRE: Underrun Interrupt Disable**

0 = No effect.

1 = Disables the corresponding interrupt.



36.14.15 HSMCI Interrupt Mask Register

Name: HSMCI_IMR

Address: 0x4000004C

Access: Read-only

31	30	29	28	27	26	25	24
UNRE	OVRE	ACKRCVE	ACKRCV	XFRDONE	FIFOEMPTY	–	–
23	22	21	20	19	18	17	16
CSTOE	DTOE	DCRCE	RTOE	RENDE	RCRCE	RDIRE	RINDE
15	14	13	12	11	10	9	8
TXBUFE	RXBUFF	CSRCV	SDIOWAIT	–	–	–	SDIOIRQA
7	6	5	4	3	2	1	0
ENDTX	ENDRX	NOTBUSY	DTIP	BLKE	TXRDY	RXRDY	CMDRDY

- **CMDRDY: Command Ready Interrupt Mask**
- **RXRDY: Receiver Ready Interrupt Mask**
- **TXRDY: Transmit Ready Interrupt Mask**
- **BLKE: Data Block Ended Interrupt Mask**
- **DTIP: Data Transfer in Progress Interrupt Mask**
- **NOTBUSY: Data Not Busy Interrupt Mask**
- **ENDRX: End of Receive Buffer Interrupt Mask**
- **ENDTX: End of Transmit Buffer Interrupt Mask**
- **SDIOIRQA: SDIO Interrupt for Slot A Interrupt Mask**
- **SDIOWAIT: SDIO Read Wait Operation Status Interrupt Mask**
- **CSRCV: Completion Signal Received Interrupt Mask**
- **RXBUFF: Receive Buffer Full Interrupt Mask**
- **TXBUFE: Transmit Buffer Empty Interrupt Mask**
- **RINDE: Response Index Error Interrupt Mask**
- **RDIRE: Response Direction Error Interrupt Mask**
- **RCRCE: Response CRC Error Interrupt Mask**
- **RENDE: Response End Bit Error Interrupt Mask**
- **RTOE: Response Time-out Error Interrupt Mask**
- **DCRCE: Data CRC Error Interrupt Mask**

- **DTOE: Data Time-out Error Interrupt Mask**
- **CSTOE: Completion Signal Time-out Error Interrupt Mask**
- **FIFOEMPTY: FIFO Empty Interrupt Mask**
- **XFRDONE: Transfer Done Interrupt Mask**
- **ACKRCV: Boot Operation Acknowledge Received Interrupt Mask**
- **ACKRCVE: Boot Operation Acknowledge Error Interrupt Mask**
- **OVRE: Overrun Interrupt Mask**
- **UNRE: Underrun Interrupt Mask**

0 = The corresponding interrupt is not enabled.

1 = The corresponding interrupt is enabled.



36.14.16 HSMCI Configuration Register

Name: HSMCI_CFG

Address: 0x40000054

Access: Read-write

31	30	29	28	27	26	25	24
		–	–	–	–	–	–
23	22	21	20	19	18	17	16
–	–	–	–	–	–	–	–
15	14	13	12	11	10	9	8
–	–	–	LSYNC	–	–	–	HSMODE
7	6	5	4	3	2	1	0
–	–	–	FERRCTRL	–	–	–	FIFOMODE

This register can only be written if the WPEN bit is cleared in “HSMCI Write Protect Mode Register” on page 903.

• **FIFOMODE: HSMCI Internal FIFO control mode**

0 = A write transfer starts when a sufficient amount of data is written into the FIFO.

When the block length is greater than or equal to 3/4 of the HSMCI internal FIFO size, then the write transfer starts as soon as half the FIFO is filled. When the block length is greater than or equal to half the internal FIFO size, then the write transfer starts as soon as one quarter of the FIFO is filled. In other cases, the transfer starts as soon as the total amount of data is written in the internal FIFO.

1 = A write transfer starts as soon as one data is written into the FIFO.

• **FERRCTRL: Flow Error flag reset control mode**

0 = When an underflow/overflow condition flag is set, a new Write/Read command is needed to reset the flag.

1 = When an underflow/overflow condition flag is set, a read status resets the flag.

• **HSMODE: High Speed Mode**

0 = Default bus timing mode.

1 = If set to one, the host controller outputs command line and data lines on the rising edge of the card clock. The Host driver shall check the high speed support in the card registers.

• **LSYNC: Synchronize on the last block**

0 = The pending command is sent at the end of the current data block.

1 = The pending command is sent at the end of the block transfer when the transfer length is not infinite. (block count shall be different from zero)

36.14.17 HSMCI Write Protect Mode Register

Name: HSMCI_WPMR

Address: 0x400000E4

Access: Read-write

31	30	29	28	27	26	25	24
WP_KEY (0x4D => "M")							
23	22	21	20	19	18	17	16
WP_KEY (0x43 => "C")							
15	14	13	12	11	10	9	8
WP_KEY (0x49 => "I")							
7	6	5	4	3	2	1	0
							WP_EN

- **WP_EN: Write Protection Enable**

0 = Disables the Write Protection if WP_KEY corresponds to 0x4D4349 ("MCI" in ASCII).

1 = Enables the Write Protection if WP_KEY corresponds to 0x4D4349 ("MCI" in ASCII).

- **WP_KEY: Write Protection Key password**

Should be written at value **0x4D4349** (ASCII code for "MCI"). Writing any other value in this field has no effect.

Protects the registers:

- ["HSMCI Mode Register"](#)
- ["HSMCI Data Timeout Register"](#)
- ["HSMCI SDCard/SDIO Register"](#)
- ["HSMCI Completion Signal Timeout Register"](#)
- ["HSMCI Configuration Register"](#)

36.14.18 HSMCI Write Protect Status Register

Name: HSMCI_WPSR

Address: 0x400000E8

Access: Read-only

31	30	29	28	27	26	25	24
–	–	–	–	–	–	–	–
23	22	21	20	19	18	17	16
WP_VSRC							
15	14	13	12	11	10	9	8
WP_VSRC							
7	6	5	4	3	2	1	0
–	–	–	–	WP_VS			

- **WP_VS: Write Protection Violation Status**

Value	Name	Description
0	NONE	No Write Protection Violation occurred since the last read of this register (WP_SR)
1	WRITE	Write Protection detected unauthorized attempt to write a control register had occurred (since the last read.)
2	RESET	Software reset had been performed while Write Protection was enabled (since the last read).
3	BOTH	Both Write Protection violation and software reset with Write Protection enabled have occurred since the last read.

- **WP_VSRC: Write Protection Violation SouRCe**

When WPVS is active, this field indicates the write-protected register (through address offset or code) in which a write access has been attempted.

37. Pulse Width Modulation Controller (PWM)

37.1 Description

The Pulse Width Modulation Controller (PWM) macrocell controls 4 channels independently. Each channel controls two complementary square output waveforms. Characteristics of the output waveforms such as period, duty-cycle, polarity and dead-times (also called dead-bands or non-overlapping times) are configured through the user interface. Each channel selects and uses one of the clocks provided by the clock generator. The clock generator provides several clocks resulting from the division of the PWM master clock (MCK).

All PWM macrocell accesses are made through registers mapped on the peripheral bus. All channels integrate a double buffering system in order to prevent an unexpected output waveform while modifying the period, the duty-cycle or the dead-times.

Channels can be linked together as synchronous channels to be able to update their duty-cycle or dead-times at the same time.

The update of duty-cycles of synchronous channels can be performed by the Peripheral DMA Controller Channel (PDC) which offers buffer transfer without processor Intervention.

The PWM macrocell provides 8 independent comparison units capable of comparing a programmed value to the counter of the synchronous channels (counter of channel 0). These comparisons are intended to generate software interrupts, to trigger pulses on the 2 independent event lines (in order to synchronize ADC conversions with a lot of flexibility independently of the PWM outputs) and to trigger PDC transfer requests.

The PWM outputs can be overridden synchronously or asynchronously to their channel counter.

The PWM block provides a fault protection mechanism with 6 fault inputs, capable of detecting a fault condition and to override the PWM outputs asynchronously (outputs forced to 0, 1).

For safety usage, some configuration registers are write-protected.

37.2 Embedded Characteristics

- One Four-channel 16-bit PWM Controller, 16-bit counter per channel
- Common clock generator, providing Thirteen Different Clocks
 - A Modulo n counter providing eleven clocks
 - Two independent Linear Dividers working on modulo n counter outputs
 - High Frequency Asynchronous clocking mode
- Independent channel programming
 - Independent Enable Disable Commands
 - Independent Clock Selection
 - Independent Period and Duty Cycle, with Double Buffering
 - Programmable selection of the output waveform polarity
 - Programmable center or left aligned output waveform
 - Independent Output Override for each channel
 - Independent complementary Outputs with 12-bit dead time generator for each channel
 - Independent Enable Disable Commands

- Independent Clock Selection
- Independent Period and Duty Cycle, with Double Buffering
- Synchronous Channel mode
 - Synchronous Channels share the same counter
 - Mode to update the synchronous channels registers after a programmable number of periods
- Connection to one PDC channel
 - Provides Buffer transfer without processor intervention, to update duty cycle of synchronous channels
- Two independent event lines which can send up to 4 triggers on ADC within a period
- One programmable Fault Input providing an asynchronous protection of outputs
- Stepper motor control (2 Channels)

37.3 Block Diagram

Figure 37-1. Pulse Width Modulation Controller Block Diagram

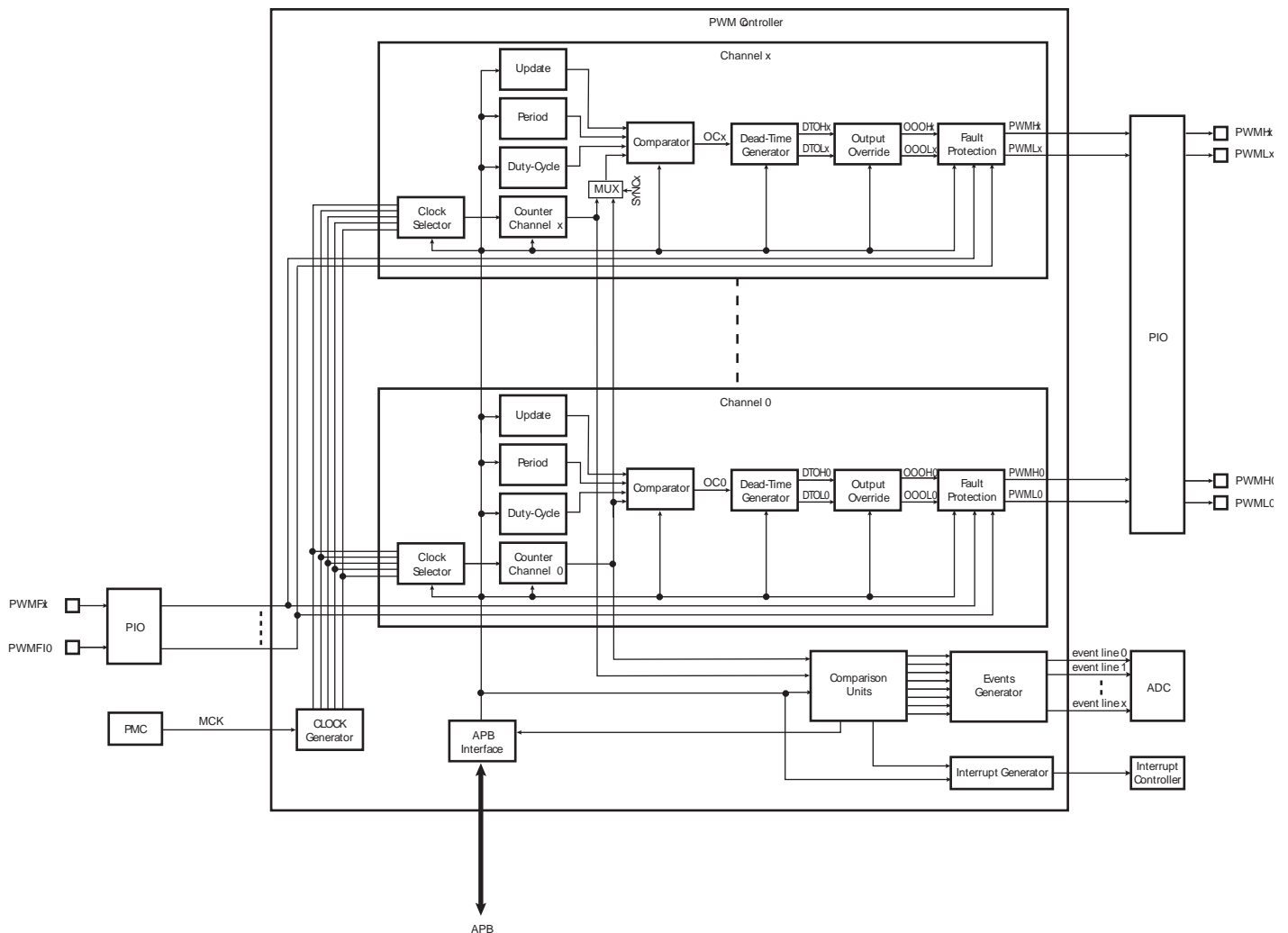

37.4 I/O Lines Description

Each channel outputs two complementary external I/O lines.

Table 37-1. I/O Line Description

Name	Description	Type
PWMHx	PWM Waveform Output High for channel x	Output
PWMLx	PWM Waveform Output Low for channel x	Output
PWMFlx	PWM Fault Input x	Input

37.5 Product Dependencies

37.5.1 I/O Lines

The pins used for interfacing the PWM are multiplexed with PIO lines. The programmer must first program the PIO controller to assign the desired PWM pins to their peripheral function. If I/O lines of the PWM are not used by the application, they can be used for other purposes by the PIO controller.

All of the PWM outputs may or may not be enabled. If an application requires only four channels, then only four PIO lines will be assigned to PWM outputs.

Table 37-2. I/O Lines

Instance	Signal	I/O Line	Peripheral
PWM	PWMFI0	PA9	C
PWM	PWMH0	PA0	A
PWM	PWMH0	PA11	B
PWM	PWMH0	PA23	B
PWM	PWMH0	PB0	A
PWM	PWMH0	PC18	B
PWM	PWMH1	PA1	A
PWM	PWMH1	PA12	B
PWM	PWMH1	PA24	B
PWM	PWMH1	PB1	A
PWM	PWMH1	PC19	B
PWM	PWMH2	PA2	A
PWM	PWMH2	PA13	B
PWM	PWMH2	PA25	B
PWM	PWMH2	PB4	B
PWM	PWMH2	PC20	B
PWM	PWMH3	PA7	B
PWM	PWMH3	PA14	B
PWM	PWMH3	PA17	C
PWM	PWMH3	PB14	B

Table 37-2. I/O Lines

PWM	PWMH3	PC21	B
PWM	PWML0	PA19	B
PWM	PWML0	PB5	B
PWM	PWML0	PC0	B
PWM	PWML0	PC13	B
PWM	PWML1	PA20	B
PWM	PWML1	PB12	A
PWM	PWML1	PC1	B
PWM	PWML1	PC15	B
PWM	PWML2	PA16	C
PWM	PWML2	PA30	A
PWM	PWML2	PB13	A
PWM	PWML2	PC2	B
PWM	PWML3	PA15	C
PWM	PWML3	PC3	B
PWM	PWML3	PC22	B

37.5.2 Power Management

The PWM is not continuously clocked. The programmer must first enable the PWM clock in the Power Management Controller (PMC) before using the PWM. However, if the application does not require PWM operations, the PWM clock can be stopped when not needed and be restarted later. In this case, the PWM will resume its operations where it left off.

In the PWM description, Master Clock (MCK) is the clock of the peripheral bus to which the PWM is connected.

37.5.3 Interrupt Sources

The PWM interrupt line is connected on one of the internal sources of the Interrupt Controller. Using the PWM interrupt requires the Interrupt Controller to be programmed first. Note that it is not recommended to use the PWM interrupt line in edge sensitive mode.

Table 37-3. Peripheral IDs

Instance	ID
PWM	31

37.5.4 Fault Inputs

The PWM has the FAULT inputs connected to the different modules. Please refer to the implementation of these module within the product for detailed information about the fault generation procedure. The PWM receives faults from PIO inputs, PMC, ADC controller, Analog Comparator Controller and Timer/Counters

Table 37-4. Fault Inputs

Fault Inputs	External PWM Fault Input Number	Polarity Level ⁽¹⁾	Fault Input ID
PA9	PWMFIO	User Defined	0
Main OSC	–	1	1
ADC	–	1	2
Analog Comparator	–	1	3
Timer0	1	1	4
Timer1	–	1	5

Note: 1. FPOL bit in PWMC_FMR.

37.6 Functional Description

The PWM macrocell is primarily composed of a clock generator module and 4 channels.

- Clocked by the master clock (MCK), the clock generator module provides 13 clocks.
- Each channel can independently choose one of the clock generator outputs.
- Each channel generates an output waveform with attributes that can be defined independently for each channel through the user interface registers.

37.6.1 PWM Clock Generator

Figure 37-2. Functional View of the Clock Generator Block Diagram

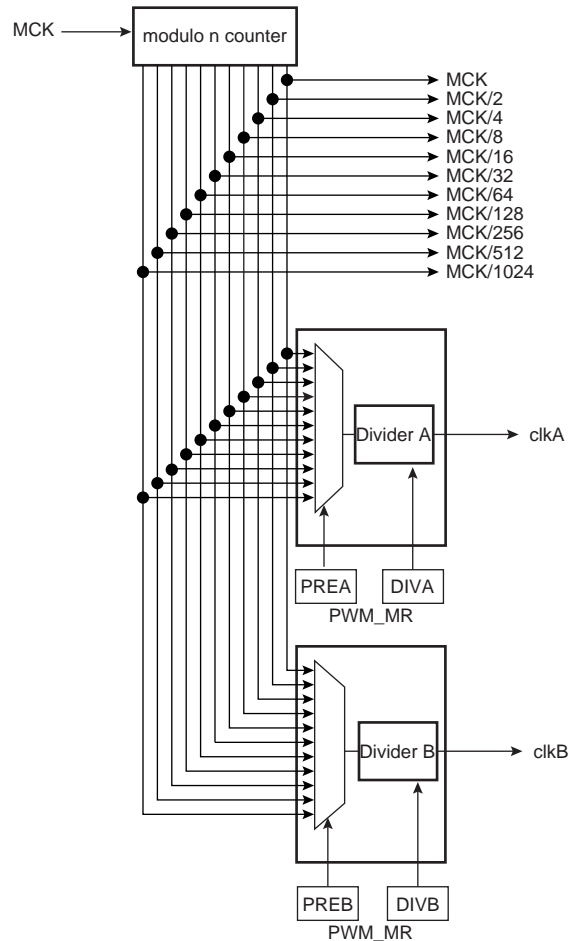

The PWM master clock (MCK) is divided in the clock generator module to provide different clocks available for all channels. Each channel can independently select one of the divided clocks.

The clock generator is divided in three blocks:

- a modulo n counter which provides 11 clocks: F_{MCK} , $F_{MCK}/2$, $F_{MCK}/4$, $F_{MCK}/8$, $F_{MCK}/16$, $F_{MCK}/32$, $F_{MCK}/64$, $F_{MCK}/128$, $F_{MCK}/256$, $F_{MCK}/512$, $F_{MCK}/1024$
- two linear dividers (1, 1/2, 1/3, ... 1/255) that provide two separate clocks: clkA and clkB

Each linear divider can independently divide one of the clocks of the modulo n counter. The selection of the clock to be divided is made according to the PREA (PREB) field of the PWM Clock register (PWM_CLK). The resulting clock clkA (clkB) is the clock selected divided by DIVA (DIVB) field value.

After a reset of the PWM controller, DIVA (DIVB) and PREA (PREB) are set to 0. This implies that after reset clkA (clkB) are turned off.

At reset, all clocks provided by the modulo n counter are turned off except clock "MCK". This situation is also true when the PWM master clock is turned off through the Power Management Controller.

CAUTION:

- Before using the PWM macrocell, the programmer must first enable the PWM clock in the Power Management Controller (PMC).

37.6.2 PWM Channel

37.6.2.1 Channel Block Diagram

Figure 37-3. Functional View of the Channel Block Diagram

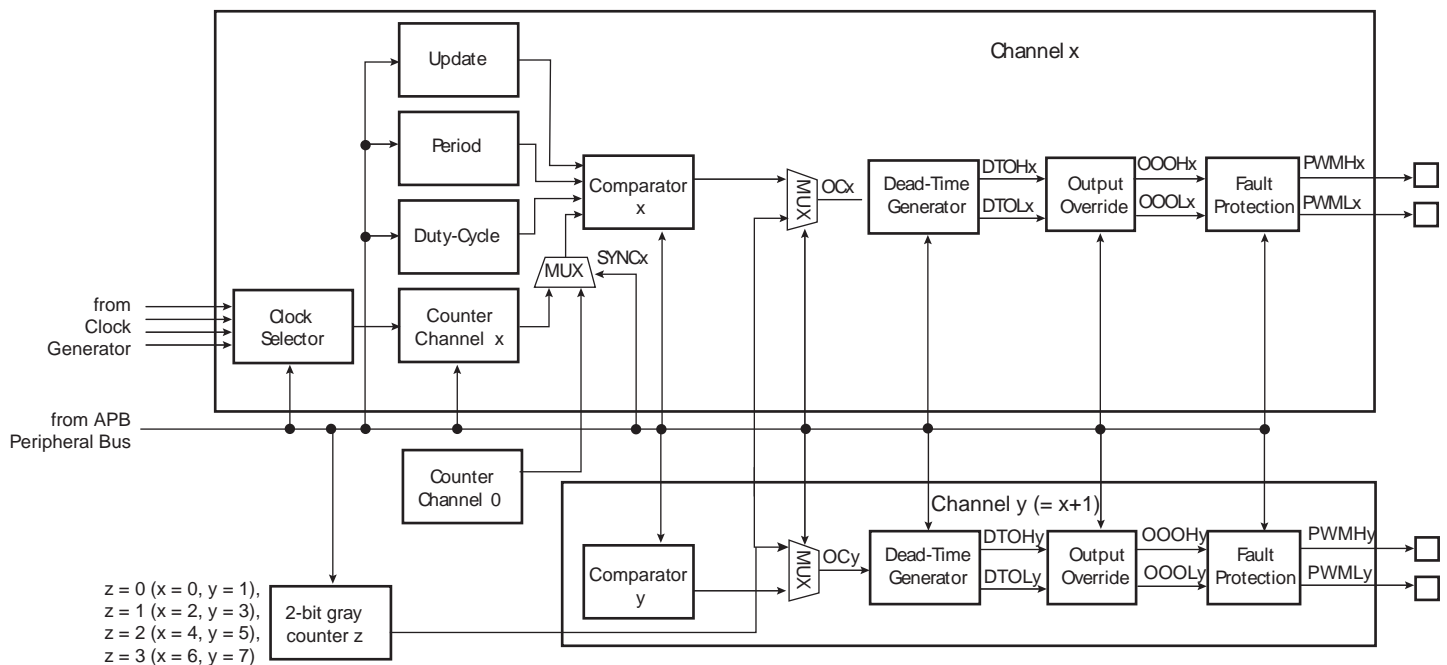

Each of the 4 channels is composed of six blocks:

- A clock selector which selects one of the clocks provided by the clock generator (described in [Section 37.6.1 on page 910](#)).
- A counter clocked by the output of the clock selector. This counter is incremented or decremented according to the channel configuration and comparators matches. The size of the counter is 16 bits.
- A comparator used to compute the OCx output waveform according to the counter value and the configuration. The counter value can be the one of the channel counter or the one of the channel 0 counter according to SYNCx bit in the “[PWM Sync Channels Mode Register](#)” on [page 942](#) (PWM_SCM).
- A 2-bit configurable gray counter enables the stepper motor driver. One gray counter drives 2 channels.

- A dead-time generator providing two complementary outputs (DTHx/DTOLx) which allows to drive external power control switches safely.
- An output override block that can force the two complementary outputs to a programmed value (OOHx/OOOLx).
- An asynchronous fault protection mechanism that has the highest priority to override the two complementary outputs (PWMHx/PWMLx) in case of fault detection (outputs forced to 0, 1).

37.6.2.2 Comparator

The comparator continuously compares its counter value with the channel period defined by CPRD in the “PWM Channel Period Register” on page 974 (PWM_CPRDx) and the duty-cycle defined by CDTY in the “PWM Channel Duty Cycle Register” on page 972 (PWM_CDTYx) to generate an output signal OCx accordingly.

The different properties of the waveform of the output OCx are:

- the **clock selection**. The channel counter is clocked by one of the clocks provided by the clock generator described in the previous section. This channel parameter is defined in the CPRE field of the “PWM Channel Mode Register” on page 970 (PWM_CMRx). This field is reset at 0.
- the **waveform period**. This channel parameter is defined in the CPRD field of the PWM_CPRDx register.

If the waveform is left aligned, then the output waveform period depends on the counter source clock and can be calculated:

By using the PWM master clock (MCK) divided by an X given prescaler value (with X being 1, 2, 4, 8, 16, 32, 64, 128, 256, 512, or 1024), the resulting period formula will be:

$$\frac{(X \times CPRD)}{MCK}$$

By using the PWM master clock (MCK) divided by one of both DIVA or DIVB divider, the formula becomes, respectively:

$$\frac{(CPRD \times DIVA)}{MCK} \text{ or } \frac{(CPRD \times DIVB)}{MCK}$$

If the waveform is center aligned then the output waveform period depends on the counter source clock and can be calculated:

By using the PWM master clock (MCK) divided by an X given prescaler value (with X being 1, 2, 4, 8, 16, 32, 64, 128, 256, 512, or 1024). The resulting period formula will be:

$$\frac{(2 \times X \times CPRD)}{MCK}$$

By using the PWM master clock (MCK) divided by one of both DIVA or DIVB divider, the formula becomes, respectively:

$$\frac{(2 \times CPRD \times DIVA)}{MCK} \text{ or } \frac{(2 \times CPRD \times DIVB)}{MCK}$$

- the **waveform duty-cycle**. This channel parameter is defined in the CDTY field of the PWM_CDTYx register.
If the waveform is left aligned then:

$$\text{duty cycle} = \frac{(\text{period} - 1 / f_{\text{channel_x_clock}} \times \text{CDTY})}{\text{period}}$$

If the waveform is center aligned, then:

$$\text{duty cycle} = \frac{((\text{period} / 2) - 1 / f_{\text{channel_x_clock}} \times \text{CDTY})}{(\text{period} / 2)}$$

- the **waveform polarity**. At the beginning of the period, the signal can be at high or low level. This property is defined in the CPOL field of the PWM_CMRx register. By default the signal starts by a low level.
- the **waveform alignment**. The output waveform can be left or center aligned. Center aligned waveforms can be used to generate non overlapped waveforms. This property is defined in the CALG field of the PWM_CMRx register. The default mode is left aligned.

Figure 37-4. Non Overlapped Center Aligned Waveforms

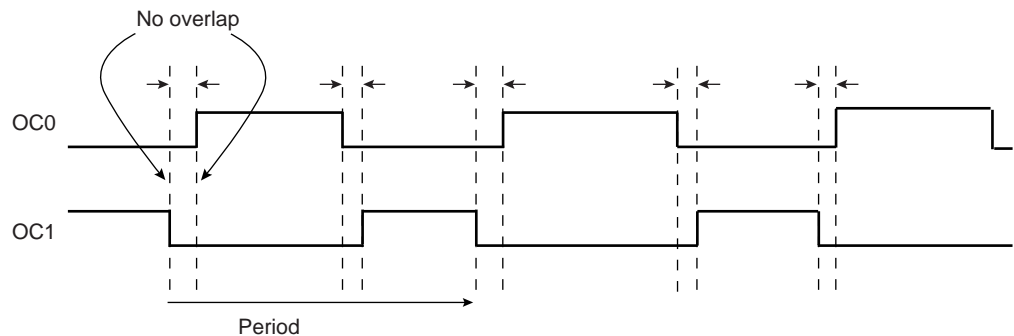

Note: 1. See [Figure 37-5 on page 914](#) for a detailed description of center aligned waveforms.

When center aligned, the channel counter increases up to CPRD and decreases down to 0. This ends the period.

When left aligned, the channel counter increases up to CPRD and is reset. This ends the period.

Thus, for the same CPRD value, the period for a center aligned channel is twice the period for a left aligned channel.

Waveforms are fixed at 0 when:

- CDTY = CPRD and CPOL = 0
- CDTY = 0 and CPOL = 1

Waveforms are fixed at 1 (once the channel is enabled) when:

- CDTY = 0 and CPOL = 0
- CDTY = CPRD and CPOL = 1

The waveform polarity must be set before enabling the channel. This immediately affects the channel output level.

Modifying CPOL in “[PWM Channel Mode Register](#)” on [page 970](#) while the channel is enabled can lead to an unexpected behavior of the device being driven by PWM.

Besides generating output signals OCx, the comparator generates interrupts in function of the counter value. When the output waveform is left aligned, the interrupt occurs at the end of the counter period. When the output waveform is center aligned, the bit CES of the PWM_CMRx register defines when the channel counter interrupt occurs. If CES is set to 0, the interrupt

occurs at the end of the counter period. If CES is set to 1, the interrupt occurs at the end of the counter period and at half of the counter period.

Figure 37-5 “Waveform Properties” illustrates the counter interrupts in function of the configuration.

Figure 37-5. Waveform Properties

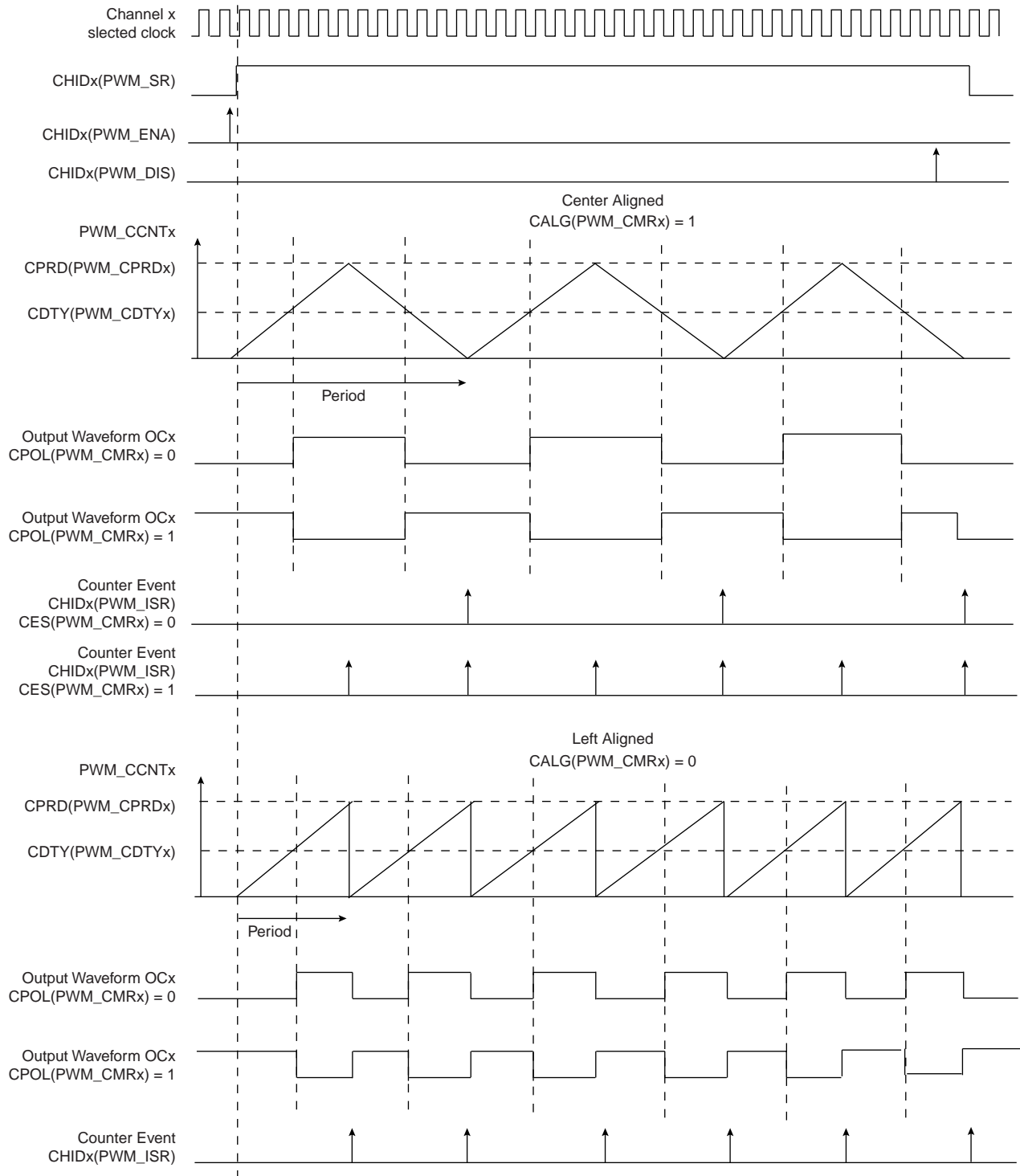

37.6.2.3 2-bit Gray Up/Down Counter for Stepper Motor

It is possible to configure a couple of channels to provide a 2-bit gray count waveform on 2 outputs. Dead-Time Generator and other downstream logic can be configured on these channels.

Up or down count mode can be configured on-the-fly by means of PWM_SMMR configuration registers.

When GCEN0 is set to 1, channels 0 and 1 outputs are driven with gray counter.

Figure 37-6. 2-bit Gray Up/Down Counter

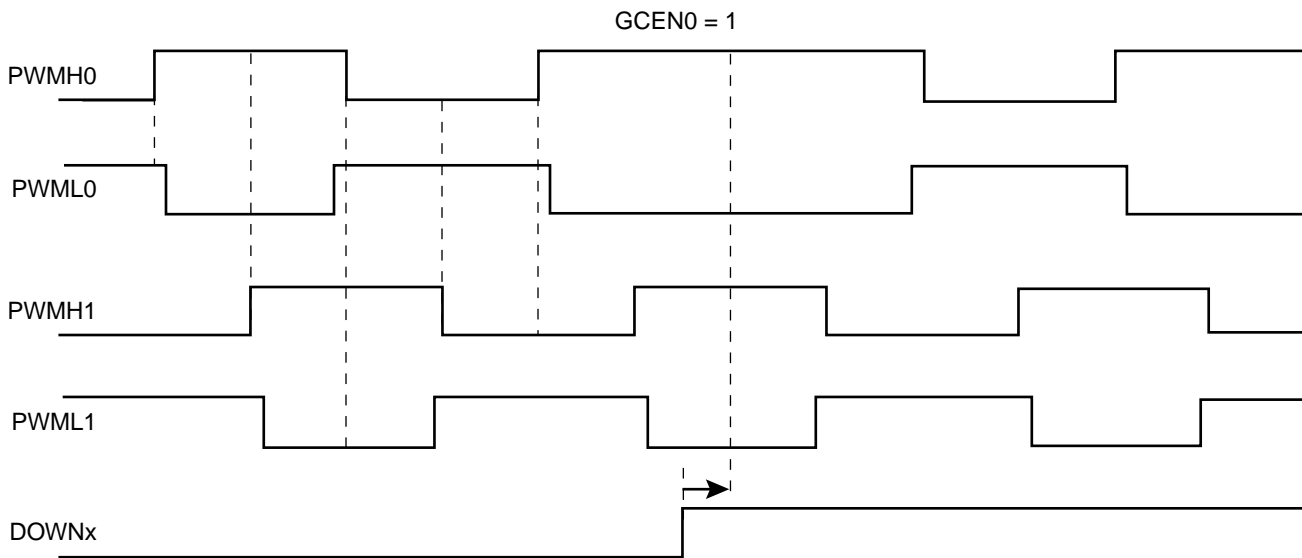

37.6.2.4 Dead-Time Generator

The dead-time generator uses the comparator output OCx to provide the two complementary outputs DTOHx and DTOLx, which allows the PWM macrocell to drive external power control switches safely. When the dead-time generator is enabled by setting the bit DTE to 1 or 0 in the “PWM Channel Mode Register” (PWM_CMRx), dead-times (also called dead-bands or non-overlapping times) are inserted between the edges of the two complementary outputs DTOHx and DTOLx. Note that enabling or disabling the dead-time generator is allowed only if the channel is disabled.

The dead-time is adjustable by the “PWM Channel Dead Time Register” (PWM_DT_x). Both outputs of the dead-time generator can be adjusted separately by DTH and DTL. The dead-time values can be updated synchronously to the PWM period by using the “PWM Channel Dead Time Update Register” (PWM_DTUPD_x).

The dead-time is based on a specific counter which uses the same selected clock that feeds the channel counter of the comparator. Depending on the edge and the configuration of the dead-time, DTOHx and DTOLx are delayed until the counter has reached the value defined by DTH or DTL. An inverted configuration bit (DTHI and DTLI bit in the PWM_CMRx register) is provided for each output to invert the dead-time outputs. The following figure shows the waveform of the dead-time generator.

Figure 37-7. Complementary Output Waveforms

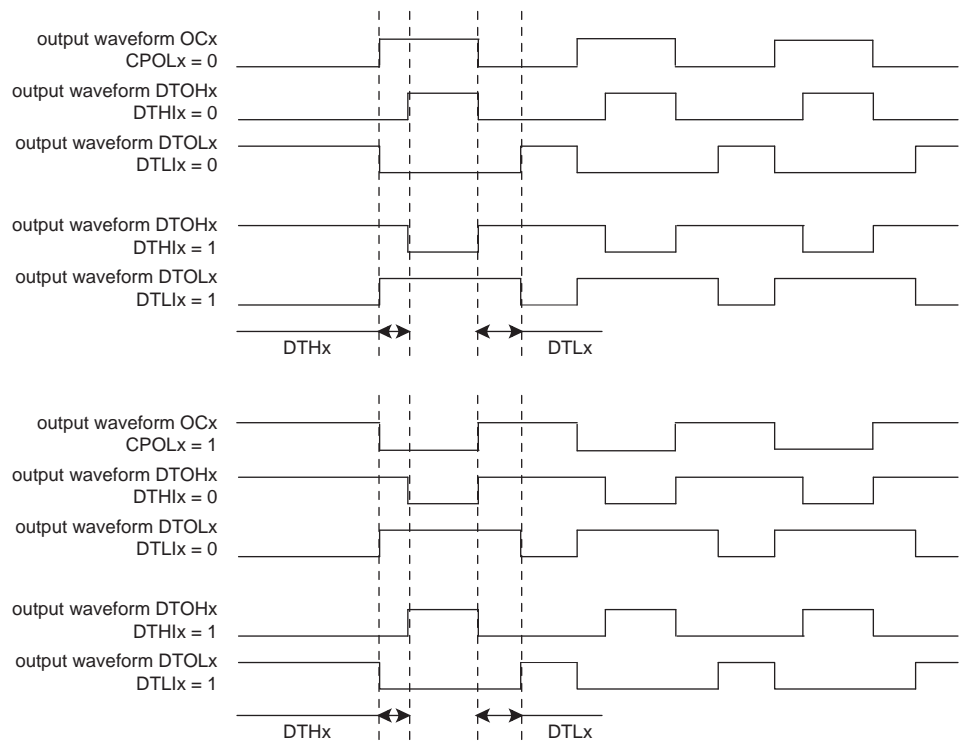

37.6.2.5 Output Override

The two complementary outputs DTHx and DTOLx of the dead-time generator can be forced to a value defined by the software.

Figure 37-8. Override Output Selection

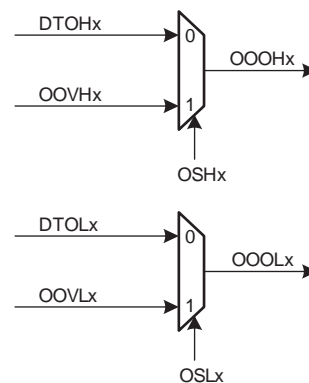

The fields OSHx and OSLx in the “PWM Output Selection Register” (PWM_OS) allow the outputs of the dead-time generator DTHx and DTOLx to be overridden by the value defined in the fields OOVHx and OOVLx in the “PWM Output Override Value Register” (PWM_OOV).

The set registers “PWM Output Selection Set Register” and “PWM Output Selection Set Update Register” (PWM_OSS and PWM_OSSUPD) enable the override of the outputs of a channel regardless of other channels. In the same way, the clear registers “PWM Output Selection Clear Register” and “PWM Output Selection Clear Update Register” (PWM_OSC and PWM_OSCUPD) disable the override of the outputs of a channel regardless of other channels.

By using buffer registers PWM_OSSUPD and PWM_OSCUPD, the output selection of PWM outputs is done synchronously to the channel counter, at the beginning of the next PWM period.

By using registers PWM_OSS and PWM_OSC, the output selection of PWM outputs is done asynchronously to the channel counter, as soon as the register is written.

The value of the current output selection can be read in PWM_OS.

While overriding PWM outputs, the channel counters continue to run, only the PWM outputs are forced to user defined values.

37.6.2.6 Fault Protection

6 inputs provide fault protection which can force any of the PWM output pair to a programmable value. This mechanism has priority over output overriding.

Figure 37-9. Fault Protection

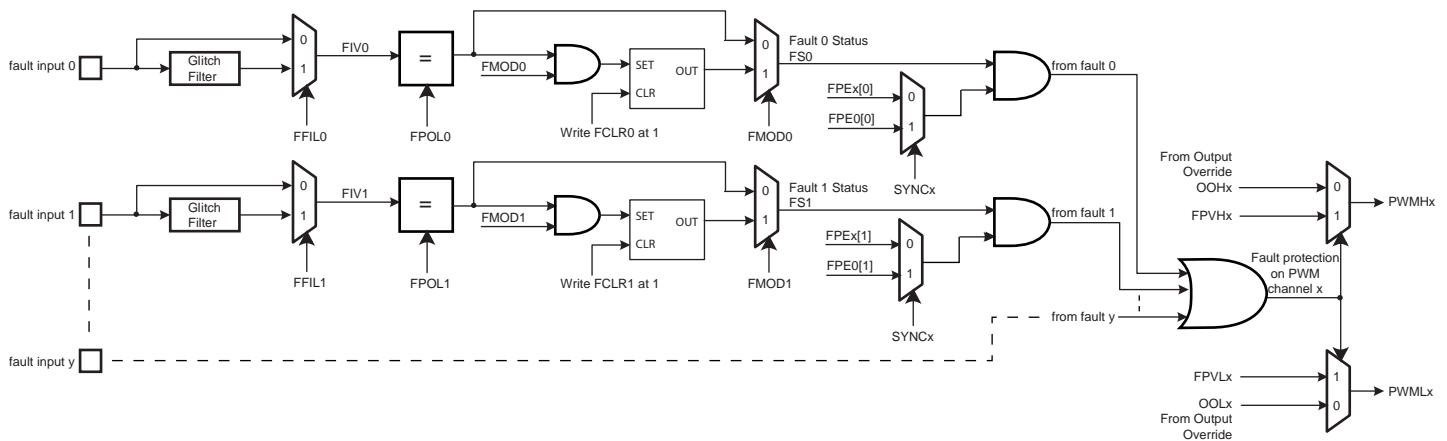

The polarity level of the fault inputs is configured by the FPOL field in the “[PWM Fault Mode Register](#)” (PWM_FMR). For fault inputs coming from internal peripherals such as ADC, Timer Counter, to name but a few, the polarity level must be FPOL = 1. For fault inputs coming from external GPIO pins the polarity level depends on the user's implementation.

The configuration of the Fault Activation Mode (FMOD bit in PWM_FMR) depends on the peripheral generating the fault. If the corresponding peripheral does not have “Fault Clear” management, then the FMOD configuration to use must be FMOD = 1, to avoid spurious fault detection. Check the corresponding peripheral documentation for details on handling fault generation.

The fault inputs can be glitch filtered or not in function of the FFIL field in the PWM_FMR register. When the filter is activated, glitches on fault inputs with a width inferior to the PWM master clock (MCK) period are rejected.

A fault becomes active as soon as its corresponding fault input has a transition to the programmed polarity level. If the corresponding bit FMOD is set to 0 in the PWM_FMR register, the fault remains active as long as the fault input is at this polarity level. If the corresponding FMOD bit is set to 1, the fault remains active until the fault input is not at this polarity level anymore and until it is cleared by writing the corresponding bit FCLR in the “[PWM Fault Clear Register](#)” (PWM_FSCR). By reading the “[PWM Fault Status Register](#)” (PWM_FSR), the user can read the

current level of the fault inputs by means of the field FIV, and can know which fault is currently active thanks to the FS field.

Each fault can be taken into account or not by the fault protection mechanism in each channel. To be taken into account in the channel x, the fault y must be enabled by the bit FPEX[y] in the “PWM Fault Protection Enable Registers” (PWM_FPE1). However the synchronous channels (see [Section 37.6.2.7 “Synchronous Channels”](#)) do not use their own fault enable bits, but those of the channel 0 (bits FPE0[y]).

The fault protection on a channel is triggered when this channel is enabled and when any one of the faults that are enabled for this channel is active. It can be triggered even if the PWM master clock (MCK) is not running but only by a fault input that is not glitch filtered.

When the fault protection is triggered on a channel, the fault protection mechanism resets the counter of this channel and forces the channel outputs to the values defined by the fields FPVHx and FPVLx in the “PWM Fault Protection Value Register” (PWM_FPV). The output forcing is made asynchronously to the channel counter.

CAUTION:

- To prevent an unexpected activation of the status flag FSy in the PWM_FSR register, the FMODy bit can be set to “1” only if the FPOLy bit has been previously configured to its final value.
- To prevent an unexpected activation of the Fault Protection on the channel x, the bit FPEX[y] can be set to “1” only if the FPOLy bit has been previously configured to its final value.

If a comparison unit is enabled (see [Section 37.6.3 “PWM Comparison Units”](#)) and if a fault is triggered in the channel 0, in this case the comparison cannot match.

As soon as the fault protection is triggered on a channel, an interrupt (different from the interrupt generated at the end of the PWM period) can be generated but only if it is enabled and not masked. The interrupt is reset by reading the interrupt status register, even if the fault which has caused the trigger of the fault protection is kept active.

37.6.2.7 Synchronous Channels

Some channels can be linked together as synchronous channels. They have the same source clock, the same period, the same alignment and are started together. In this way, their counters are synchronized together.

The synchronous channels are defined by the SYNCx bits in the “[PWM Sync Channels Mode Register](#)” (PWM_SCM). Only one group of synchronous channels is allowed.

When a channel is defined as a synchronous channel, the channel 0 is automatically defined as a synchronous channel too, because the channel 0 counter configuration is used by all the synchronous channels.

If a channel x is defined as a synchronous channel, it uses the following configuration fields of the channel 0 instead of its own:

- CPRE0 field in PWM_CMRO register instead of CPREx field in PWM_CMRx register (same source clock)
- CPRD0 field in PWM_CMRO register instead of CPRDx field in PWM_CMRx register (same period)
- CALG0 field in PWM_CMRO register instead of CALGx field in PWM_CMRx register (same alignment)

Thus writing these fields of a synchronous channel has no effect on the output waveform of this channel (except channel 0 of course).

Because counters of synchronous channels must start at the same time, they are all enabled together by enabling the channel 0 (by the CHID0 bit in PWM_ENA register). In the same way, they are all disabled together by disabling channel 0 (by the CHID0 bit in PWM_DIS register). However, a synchronous channel x different from channel 0 can be enabled or disabled independently from others (by the CHIDx bit in PWM_ENA and PWM_DIS registers).

Defining a channel as a synchronous channel while it is an asynchronous channel (by writing the bit SYNCx to 1 while it was at 0) is allowed only if the channel is disabled at this time (CHIDx = 0 in PWM_SR register). In the same way, defining a channel as an asynchronous channel while it is a synchronous channel (by writing the SYNCx bit to 0 while it was 1) is allowed only if the channel is disabled at this time.

The field UPDM (Update Mode) in the PWM_SCM register allow to select one of the three methods to update the registers of the synchronous channels:

- Method 1 (UPDM = 0): the period value, the duty-cycle values and the dead-time values must be written by the CPU in their respective update registers (respectively PWM_CPRDUPDx, PWM_CDTYUPDx and PWM_DTUPDx). The update is triggered at the next PWM period as soon as the bit UPDULOCK in the “[PWM Sync Channels Update Control Register](#)” (PWM_SCUC) is set to 1 (see “[Method 1: Manual write of duty-cycle values and manual trigger of the update](#)” on page 920).
- Method 2 (UPDM = 1): the period value, the duty-cycle values, the dead-time values and the update period value must be written by the CPU in their respective update registers (respectively PWM_CPRDUPDx, PWM_CDTYUPDx and PWM_DTUPD). The update of the period value and of the dead-time values is triggered at the next PWM period as soon as the bit UPDULOCK in the “[PWM Sync Channels Update Control Register](#)” (PWM_SCUC) is set to 1. The update of the duty-cycle values and the update period value is triggered automatically after an update period defined by the field UPR in the “[PWM Sync Channels](#)

[Update Period Register](#) (PWM_SCUP) (see [“Method 2: Manual write of duty-cycle values and automatic trigger of the update”](#) on page 921).

- Method 3 (UPDM = 2): same as Method 2 apart from the fact that the duty-cycle values of ALL synchronous channels are written by the Peripheral DMA Controller (PDC) (see [“Method 3: Automatic write of duty-cycle values and automatic trigger of the update”](#) on page 923). The user can choose to synchronize the PDC transfer request with a comparison match (see [Section 37.6.3 “PWM Comparison Units”](#)), by the fields PTRM and PTRCS in the PWM_SCM register.

Table 37-5. Summary of the Update of Registers of Synchronous Channels

	UPDM=0	UPDM=1	UPDM=2
Period Value (PWM_CPRDUPDx)	Write by the CPU		
	Update is triggered at the next PWM period as soon as the bit UPDULOCK is set to 1		
Dead-Time Values (PWM_DTUPDx)	Write by the CPU		
	Update is triggered at the next PWM period as soon as the bit UPDULOCK is set to 1		
Duty-Cycle Values (PWM_CDTYUPDx)	Write by the CPU	Write by the CPU	Write by the PDC
	Update is triggered at the next PWM period as soon as the bit UPDULOCK is set to 1	Update is triggered at the next PWM period as soon as the update period counter has reached the value UPR	
Update Period Value (PWM_SCUPUPD)	Not applicable	Write by the CPU	
	Not applicable	Update is triggered at the next PWM period as soon as the update period counter has reached the value UPR	

Method 1: Manual write of duty-cycle values and manual trigger of the update

In this mode, the update of the period value, the duty-cycle values and the dead-time values must be done by writing in their respective update registers with the CPU (respectively PWM_CPRDUPDx, PWM_CDTYUPDx and PWM_DTUPDx).

To trigger the update, the user must use the bit UPDULOCK of the [“PWM Sync Channels Update Control Register”](#) (PWM_SCUC) which allows to update synchronously (at the same PWM period) the synchronous channels:

- If the bit UPDULOCK is set to 1, the update is done at the next PWM period of the synchronous channels.
- If the UPDULOCK bit is not set to 1, the update is locked and cannot be performed.

After writing the UPDULOCK bit to 1, it is held at this value until the update occurs, then it is read 0.

Sequence for Method 1:

1. Select the manual write of duty-cycle values and the manual update by setting the UPDM field to 0 in the PWM_SCM register
2. Define the synchronous channels by the SYNCx bits in the PWM_SCM register.
3. Enable the synchronous channels by writing CHID0 in the PWM_ENA register.
4. If an update of the period value and/or the duty-cycle values and/or the dead-time values is required, write registers that need to be updated (PWM_CPRDUPDx, PWM_CDTYUPDx and PWM_DTUPDx).
5. Set UPDULOCK to 1 in PWM_SCUC.
6. The update of the registers will occur at the beginning of the next PWM period. At this moment the UPDULOCK bit is reset, go to [Step 4.](#) for new values.

Figure 37-10. Method 1 (UPDM = 0)

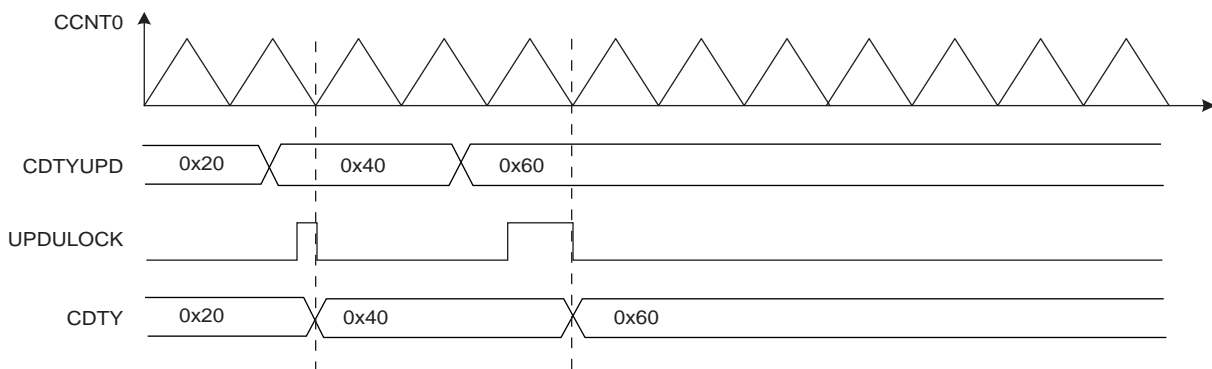

Method 2: Manual write of duty-cycle values and automatic trigger of the update

In this mode, the update of the period value, the duty-cycle values, the dead-time values and the update period value must be done by writing in their respective update registers with the CPU (respectively PWM_CPRDUPDx, PWM_CDTYUPDx, PWM_DTUPDx and PWM_SCUPUPD).

To trigger the update of the period value and the dead-time values, the user must use the bit UPDULOCK of the “[PWM Sync Channels Update Control Register](#)” (PWM_SCUC) which allows to update synchronously (at the same PWM period) the synchronous channels:

- If the bit UPDULOCK is set to 1, the update is done at the next PWM period of the synchronous channels.
- If the UPDULOCK bit is not set to 1, the update is locked and cannot be performed.

After writing the UPDULOCK bit to 1, it is held at this value until the update occurs, then it is read 0.

The update of the duty-cycle values and the update period is triggered automatically after an update period.

To configure the automatic update, the user must define a value for the Update Period by the UPR field in the “[PWM Sync Channels Update Period Register](#)” (PWM_SCUP). The PWM controller waits UPR+1 period of synchronous channels before updating automatically the duty values and the update period value.

The status of the duty-cycle value write is reported in the “PWM Interrupt Status Register 2” (PWM_ISR2) by the following flags:

- WRDY: this flag is set to 1 when the PWM Controller is ready to receive new duty-cycle values and a new update period value. It is reset to 0 when the PWM_ISR2 register is read.

Depending on the interrupt mask in the PWM_IMR2 register, an interrupt can be generated by these flags.

Sequence for Method 2:

1. Select the manual write of duty-cycle values and the automatic update by setting the field UPDM to 1 in the PWM_SCM register
2. Define the synchronous channels by the bits SYNCx in the PWM_SCM register.
3. Define the update period by the field UPR in the PWM_SCUP register.
4. Enable the synchronous channels by writing CHID0 in the PWM_ENA register.
5. If an update of the period value and/or of the dead-time values is required, write registers that need to be updated (PWM_CPRDUPDx, PWM_DTUPDx), else go to [Step 8](#).
6. Set UPDULOCK to 1 in PWM_SCUC.
7. The update of these registers will occur at the beginning of the next PWM period. At this moment the bit UPDULOCK is reset, go to [Step 5](#). for new values.
8. If an update of the duty-cycle values and/or the update period is required, check first that write of new update values is possible by polling the flag WRDY (or by waiting for the corresponding interrupt) in the PWM_ISR2 register.
9. Write registers that need to be updated (PWM_CDTYUPDx, PWM_SCUPUPD).
10. The update of these registers will occur at the next PWM period of the synchronous channels when the Update Period is elapsed. Go to [Step 8](#). for new values.

Figure 37-11. Method 2 (UPDM=1)

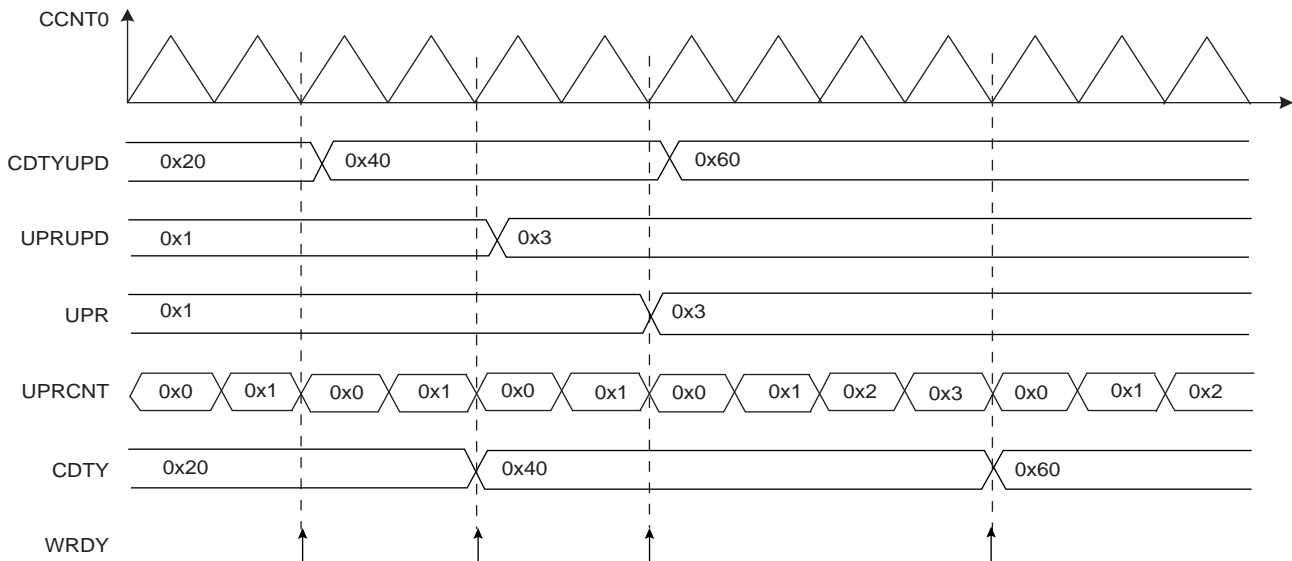

Method 3: Automatic write of duty-cycle values and automatic trigger of the update

In this mode, the update of the duty cycle values is made automatically by the Peripheral DMA Controller (PDC). The update of the period value, the dead-time values and the update period value must be done by writing in their respective update registers with the CPU (respectively PWM_CPRDUPDx, PWM_DTUPDx and PWM_SCUPUPD).

To trigger the update of the period value and the dead-time values, the user must use the bit UPDULOCK which allows to update synchronously (at the same PWM period) the synchronous channels:

- If the bit UPDULOCK is set to 1, the update is done at the next PWM period of the synchronous channels.
- If the UPDULOCK bit is not set to 1, the update is locked and cannot be performed.

After writing the UPDULOCK bit to 1, it is held at this value until the update occurs, then it is read 0.

The update of the duty-cycle values and the update period value is triggered automatically after an update period.

To configure the automatic update, the user must define a value for the Update Period by the field UPR in the “PWM Sync Channels Update Period Register” (PWM_SCUP). The PWM controller waits UPR+1 periods of synchronous channels before updating automatically the duty values and the update period value.

Using the PDC removes processor overhead by reducing its intervention during the transfer. This significantly reduces the number of clock cycles required for a data transfer, which improves microcontroller performance.

The PDC must write the duty-cycle values in the synchronous channels index order. For example if the channels 0, 1 and 3 are synchronous channels, the PDC must write the duty-cycle of the channel 0 first, then the duty-cycle of the channel 1, and finally the duty-cycle of the channel 3.

The status of the PDC transfer is reported in the “PWM Interrupt Status Register 2” (PWM_ISR2) by the following flags:

- WRDY: this flag is set to 1 when the PWM Controller is ready to receive new duty-cycle values and a new update period value. It is reset to 0 when the PWM_ISR2 register is read. The user can choose to synchronize the WRDY flag and the PDC transfer request with a comparison match (see [Section 37.6.3 “PWM Comparison Units”](#)), by the fields PTRM and PTRCS in the PWM_SCM register.
- ENDTX: this flag is set to 1 when a PDC transfer is completed
- TXBUFE: this flag is set to 1 when the PDC buffer is empty (no pending PDC transfers)
- UNRE: this flag is set to 1 when the update period defined by the UPR field has elapsed while the whole data has not been written by the PDC. It is reset to 0 when the PWM_ISR2 register is read.

Depending on the interrupt mask in the PWM_IMR2 register, an interrupt can be generated by these flags.

Sequence for Method 3:

1. Select the automatic write of duty-cycle values and automatic update by setting the field UPDM to 2 in the PWM_SCM register.
2. Define the synchronous channels by the bits SYNCx in the PWM_SCM register.
3. Define the update period by the field UPR in the PWM_SCUP register.
4. Define when the WRDY flag and the corresponding PDC transfer request must be set in the update period by the PTRM bit and the PTRCS field in the PWM_SCM register (at the end of the update period or when a comparison matches).
5. Define the PDC transfer settings for the duty-cycle values and enable it in the PDC registers
6. Enable the synchronous channels by writing CHID0 in the PWM_ENA register.
7. If an update of the period value and/or of the dead-time values is required, write registers that need to be updated (PWM_CPRDUPDx, PWM_DTUPDx), else go to [Step 10](#).
8. Set UPDULOCK to 1 in PWM_SCUC.
9. The update of these registers will occur at the beginning of the next PWM period. At this moment the bit UPDULOCK is reset, go to [Step 7](#). for new values.
10. If an update of the update period value is required, check first that write of a new update value is possible by polling the flag WRDY (or by waiting for the corresponding interrupt) in the PWM_ISR2 register, else go to [Step 13](#).
11. Write the register that needs to be updated (PWM_SCUPUPD).
12. The update of this register will occur at the next PWM period of the synchronous channels when the Update Period is elapsed. Go to [Step 10](#). for new values.
13. Check the end of the PDC transfer by the flag ENDTX. If the transfer has ended, define a new PDC transfer in the PDC registers for new duty-cycle values. Go to [Step 5](#).

Figure 37-12. Method 3 (UPDM=2 and PTRM=0)

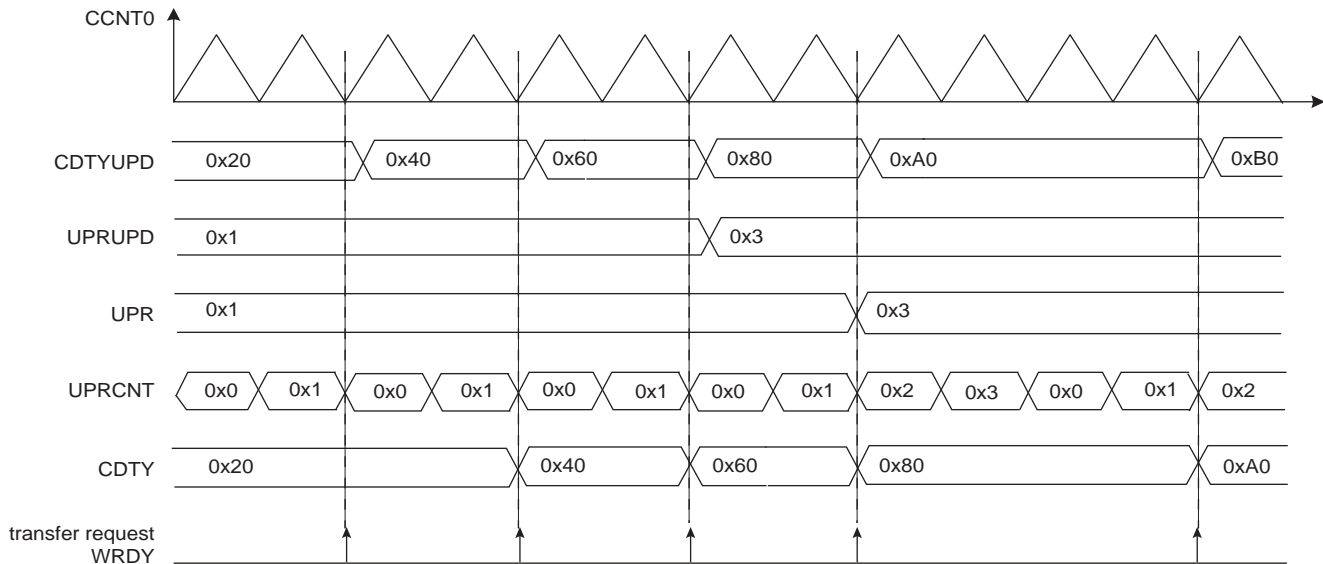
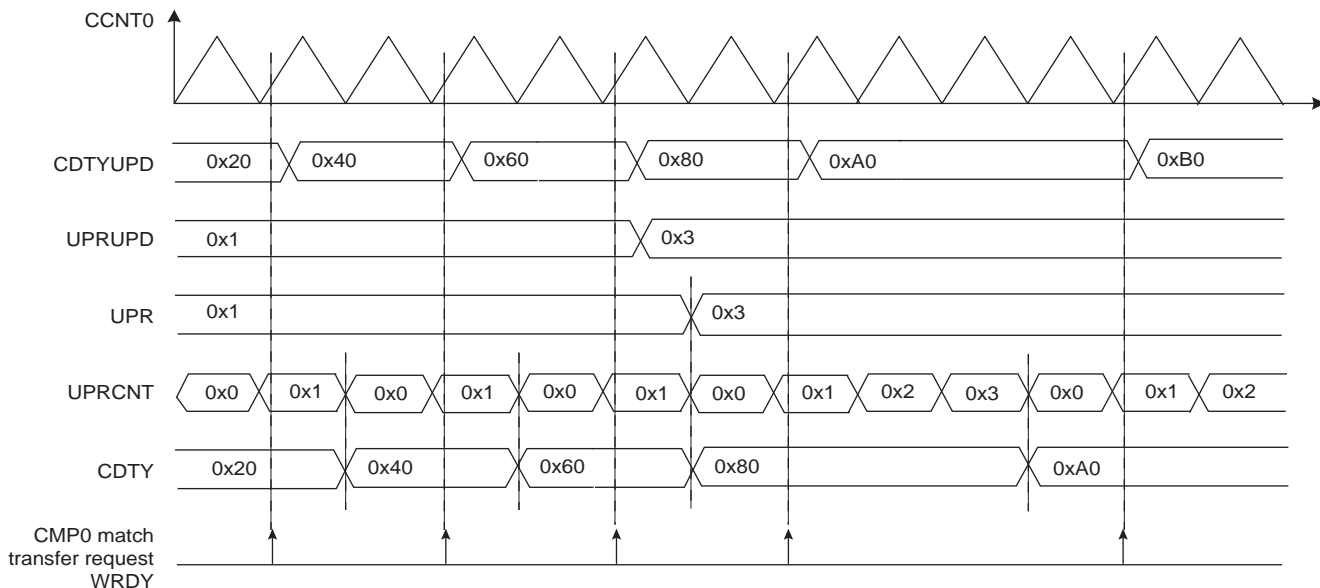

Figure 37-13. Method 3 (UPDM=2 and PTRM=1 and PTRCS=0)



37.6.3 PWM Comparison Units

The PWM provides 8 independent comparison units able to compare a programmed value with the current value of the channel 0 counter (which is the channel counter of all synchronous channels, [Section 37.6.2.7 “Synchronous Channels”](#)). These comparisons are intended to generate pulses on the event lines (used to synchronize ADC, see [Section 37.6.4 “PWM Event Lines”](#)), to generate software interrupts and to trigger PDC transfer requests for the synchronous channels (see [“Method 3: Automatic write of duty-cycle values and automatic trigger of the update”](#) on page 923).

Figure 37-14. Comparison Unit Block Diagram

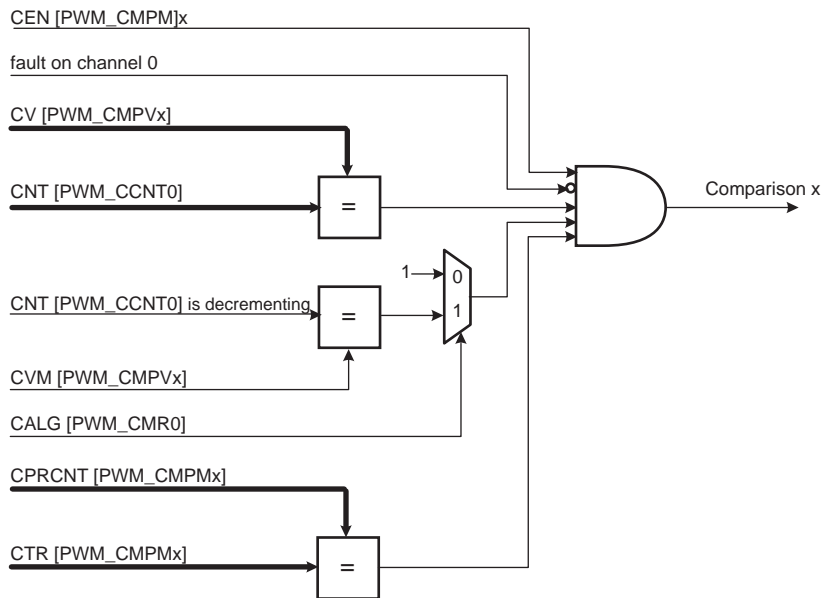

The comparison x matches when it is enabled by the bit CEN in the “[PWM Comparison x Mode Register](#)” (PWM_CMPMx for the comparison x) and when the counter of the channel 0 reaches the comparison value defined by the field CV in “[PWM Comparison x Value Register](#)” (PWM_CMPVx for the comparison x). If the counter of the channel 0 is center aligned (CALG = 1 in “[PWM Channel Mode Register](#)”), the bit CVM (in PWM_CMPVx) defines if the comparison is made when the counter is counting up or counting down (in left alignment mode CALG=0, this bit is useless).

If a fault is active on the channel 0, the comparison is disabled and cannot match (see [Section 37.6.2.6 “Fault Protection”](#)).

The user can define the periodicity of the comparison x by the fields CTR and CPR (in PWM_CMPVx). The comparison is performed periodically once every CPR+1 periods of the counter of the channel 0, when the value of the comparison period counter CPRCNT (in PWM_CMPMx) reaches the value defined by CTR. CPR is the maximum value of the comparison period counter CPRCNT. If CPR=CTR=0, the comparison is performed at each period of the counter of the channel 0.

The comparison x configuration can be modified while the channel 0 is enabled by using the “[PWM Comparison x Mode Update Register](#)” (PWM_CMPMUPDx registers for the comparison x). In the same way, the comparison x value can be modified while the channel 0 is enabled by using the “[PWM Comparison x Value Update Register](#)” (PWM_CMPVUPDx registers for the comparison x).

The update of the comparison x configuration and the comparison x value is triggered periodically after the comparison x update period. It is defined by the field CUPR in the PWM_CMPMx. The comparison unit has an update period counter independent from the period counter to trigger this update. When the value of the comparison update period counter CUPRCNT (in PWM_CMPMx) reaches the value defined by CUPR, the update is triggered. The comparison x update period CUPR itself can be updated while the channel 0 is enabled by using the PWM_CMPMUPDx register.

CAUTION: to be taken into account, the write of the register PWM_CMPVUPDx must be followed by a write of the register PWM_CMPMUPDx.

The comparison match and the comparison update can be source of an interrupt, but only if it is enabled and not masked. These interrupts can be enabled by the “[PWM Interrupt Enable Register 2](#)” and disabled by the “[PWM Interrupt Disable Register 2](#)”. The comparison match interrupt and the comparison update interrupt are reset by reading the “[PWM Interrupt Status Register 2](#)”.

Figure 37-15. Comparison Waveform

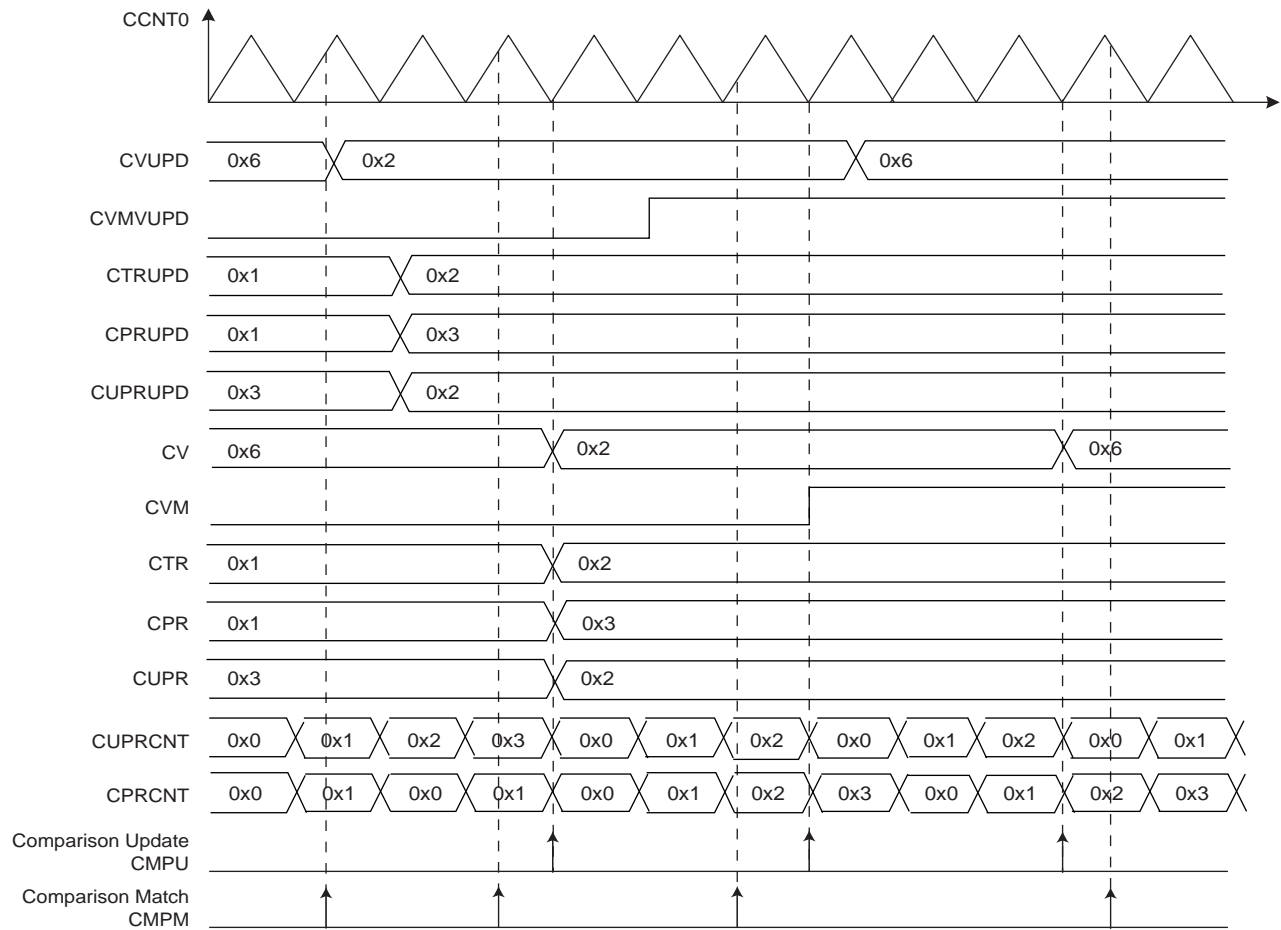

37.6.4 PWM Event Lines

The PWM provides 2 independent event lines intended to trigger actions in other peripherals (in particular for ADC (Analog-to-Digital Converter)).

A pulse (one cycle of the master clock (MCK)) is generated on an event line, when at least one of the selected comparisons is matching. The comparisons can be selected or unselected independently by the CSEL bits in the “PWM Event Line x Register” (PWM_ELMRx for the Event Line x).

Figure 37-16. Event Line Block Diagram

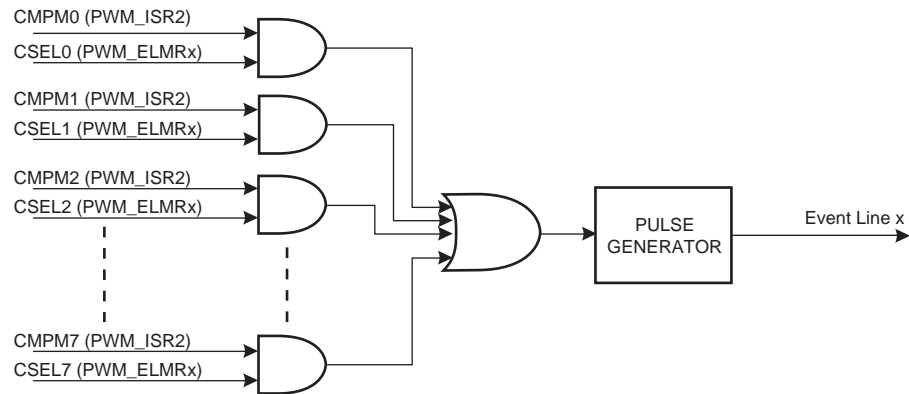

37.6.5 PWM Controller Operations

37.6.5.1 Initialization

Before enabling the channels, they must have been configured by the software application:

- Unlock User Interface by writing the WPCMD field in the PWM_WPCR Register.
- Configuration of the clock generator (DIVA, PREA, DIVB, PREB in the PWM_CLK register if required).
- Selection of the clock for each channel (CPRE field in the PWM_CMRx register)
- Configuration of the waveform alignment for each channel (CALG field in the PWM_CMRx register)
- Selection of the counter event selection (if CALG = 1) for each channel (CES field in the PWM_CMRx register)
- Configuration of the output waveform polarity for each channel (CPOL in the PWM_CMRx register)
- Configuration of the period for each channel (CPRD in the PWM_CPRDx register). Writing in PWM_CPRDx register is possible while the channel is disabled. After validation of the channel, the user must use PWM_CPRDUPDx register to update PWM_CPRDx as explained below.
- Configuration of the duty-cycle for each channel (CDTY in the PWM_CDTYx register). Writing in PWM_CDTYx register is possible while the channel is disabled. After validation of the channel, the user must use PWM_CDTYUPDx register to update PWM_CDTYx as explained below.
- Configuration of the dead-time generator for each channel (DTH and DTL in PWM_DTx) if enabled (DTE bit in the PWM_CMRx register). Writing in the PWM_DTx register is possible while the channel is disabled. After validation of the channel, the user must use PWM_DTUPDx register to update PWM_DTx
- Selection of the synchronous channels (SYNCx in the PWM_SCM register)
- Selection of the moment when the WRDY flag and the corresponding PDC transfer request are set (PTRM and PTRCS in the PWM_SCM register)
- Configuration of the update mode (UPDM in the PWM_SCM register)
- Configuration of the update period (UPR in the PWM_SCUP register) if needed.
- Configuration of the comparisons (PWM_CMPVx and PWM_CMPMx).

- Configuration of the event lines (PWM_ELMRx).
- Configuration of the fault inputs polarity (FPOL in PWM_FMR)
- Configuration of the fault protection (FMOD and FFIL in PWM_FMR, PWM_FPV and PWM_FPE1)
- Enable of the Interrupts (writing CHIDx and FCHIDx in PWM_IER1 register, and writing WRDYE, ENDTXE, TXBUFE, UNRE, CMPMx and CMPUx in PWM_IER2 register)
- Enable of the PWM channels (writing CHIDx in the PWM_ENA register)

37.6.5.2 Source Clock Selection Criteria

The large number of source clocks can make selection difficult. The relationship between the value in the “PWM Channel Period Register” (PWM_CPRDx) and the “PWM Channel Duty Cycle Register” (PWM_CDTYx) can help the user in choosing. The event number written in the Period Register gives the PWM accuracy. The Duty-Cycle quantum cannot be lower than $1/CPRDx$ value. The higher the value of PWM_CPRDx, the greater the PWM accuracy.

For example, if the user sets 15 (in decimal) in PWM_CPRDx, the user is able to set a value from between 1 up to 14 in PWM_CDTYx Register. The resulting duty-cycle quantum cannot be lower than 1/15 of the PWM period.

37.6.5.3 Changing the Duty-Cycle, the Period and the Dead-Times

It is possible to modulate the output waveform duty-cycle, period and dead-times.

To prevent unexpected output waveform, the user must use the “PWM Channel Duty Cycle Update Register”, the “PWM Channel Period Update Register” and the “PWM Channel Dead Time Update Register” (PWM_CDTYUPDx, PWM_CPRDUPDx and PWM_DTUPDx) to change waveform parameters while the channel is still enabled.

- If the channel is an asynchronous channel (SYNCx = 0 in “PWM Sync Channels Mode Register” (PWM_SCM)), these registers hold the new period, duty-cycle and dead-times values until the end of the current PWM period and update the values for the next period.
- If the channel is a synchronous channel and update method 0 is selected (SYNCx = 1 and UPDM = 0 in PWM_SCM register), these registers hold the new period, duty-cycle and dead-times values until the bit UPDULOCK is written at “1” (in “PWM Sync Channels Update Control Register” (PWM_SCUC)) and the end of the current PWM period, then update the values for the next period.
- If the channel is a synchronous channel and update method 1 or 2 is selected (SYNCx=1 and UPDM=1 or 2 in PWM_SCM register):
 - registers PWM_CPRDUPDx and PWM_DTUPDx hold the new period and dead-times values until the bit UPDULOCK is written at “1” (in PWM_SCUC register) and the end of the current PWM period, then update the values for the next period.
 - register PWM_CDTYUPDx holds the new duty-cycle value until the end of the update period of synchronous channels (when UPRCNT is equal to UPR in “PWM Sync Channels Update Period Register” (PWM_SCUP)) and the end of the current PWM period, then updates the value for the next period.

Note: If the update registers PWM_CDTYUPDx, PWM_CPRDUPDx and PWM_DTUPDx are written several times between two updates, only the last written value is taken into account.

Figure 37-17. Synchronized Period, Duty-Cycle and Dead-Times Update

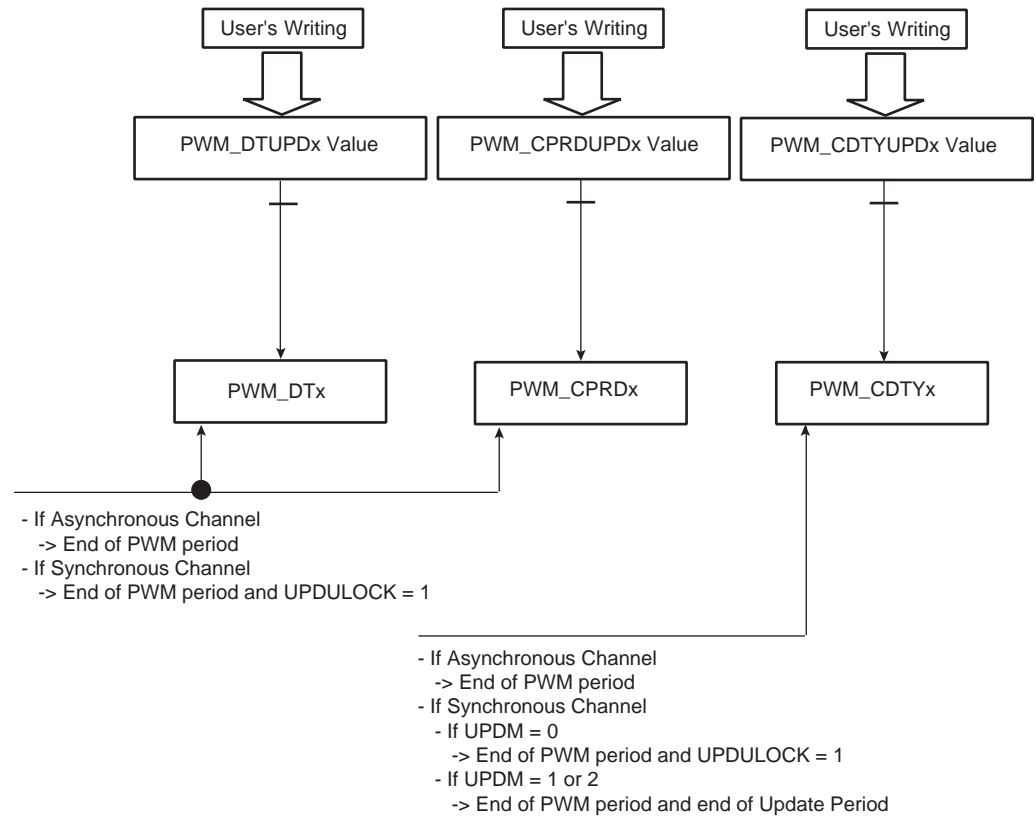

37.6.5.4 Changing the Synchronous Channels Update Period

It is possible to change the update period of synchronous channels while they are enabled. (See [“Method 2: Manual write of duty-cycle values and automatic trigger of the update”](#) on page 921 and [“Method 3: Automatic write of duty-cycle values and automatic trigger of the update”](#) on page 923.)

To prevent an unexpected update of the synchronous channels registers, the user must use the [“PWM Sync Channels Update Period Update Register”](#) (PWM_SCUPUPD) to change the update period of synchronous channels while they are still enabled. This register holds the new value until the end of the update period of synchronous channels (when UPRCNT is equal to UPR in [“PWM Sync Channels Update Period Register”](#) (PWM_SCUP)) and the end of the current PWM period, then updates the value for the next period.

Note: If the update register PWM_SCUPUPD is written several times between two updates, only the last written value is taken into account.

Note: Changing the update period does make sense only if there is one or more synchronous channels and if the update method 1 or 2 is selected (UPDM = 1 or 2 in [“PWM Sync Channels Mode Register”](#)).

Figure 37-18. Synchronized Update of Update Period Value of Synchronous Channels

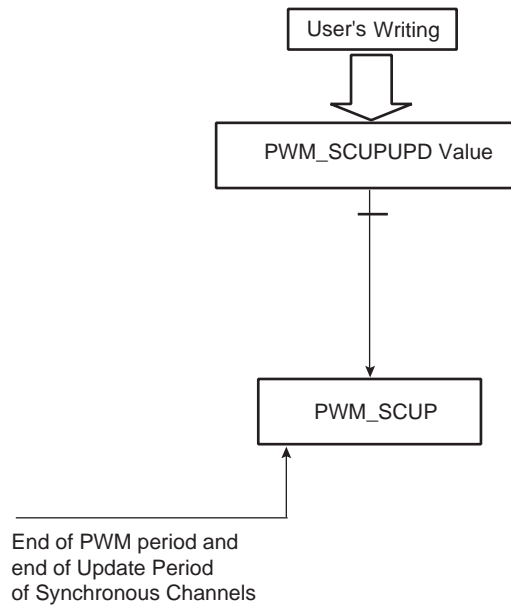

37.6.5.5 Changing the Comparison Value and the Comparison Configuration

It is possible to change the comparison values and the comparison configurations while the channel 0 is enabled (see [Section 37.6.3 “PWM Comparison Units”](#)).

To prevent unexpected comparison match, the user must use the “[PWM Comparison x Value Update Register](#)” and the “[PWM Comparison x Mode Update Register](#)” (PWM_CMPVUPDx and PWM_CMPMUPDx) to change respectively the comparison values and the comparison configurations while the channel 0 is still enabled. These registers hold the new values until the end of the comparison update period (when CUPRCNT is equal to CUPR in “[PWM Comparison x Mode Register](#)” (PWM_CMPMx) and the end of the current PWM period, then update the values for the next period.

CAUTION: to be taken into account, the write of the register PWM_CMPVUPDx must be followed by a write of the register PWM_CMPMUPDx.

Note: If the update registers PWM_CMPVUPDx and PWM_CMPMUPDx are written several times between two updates, only the last written value are taken into account.

Figure 37-19. Synchronized Update of Comparison Values and Configurations

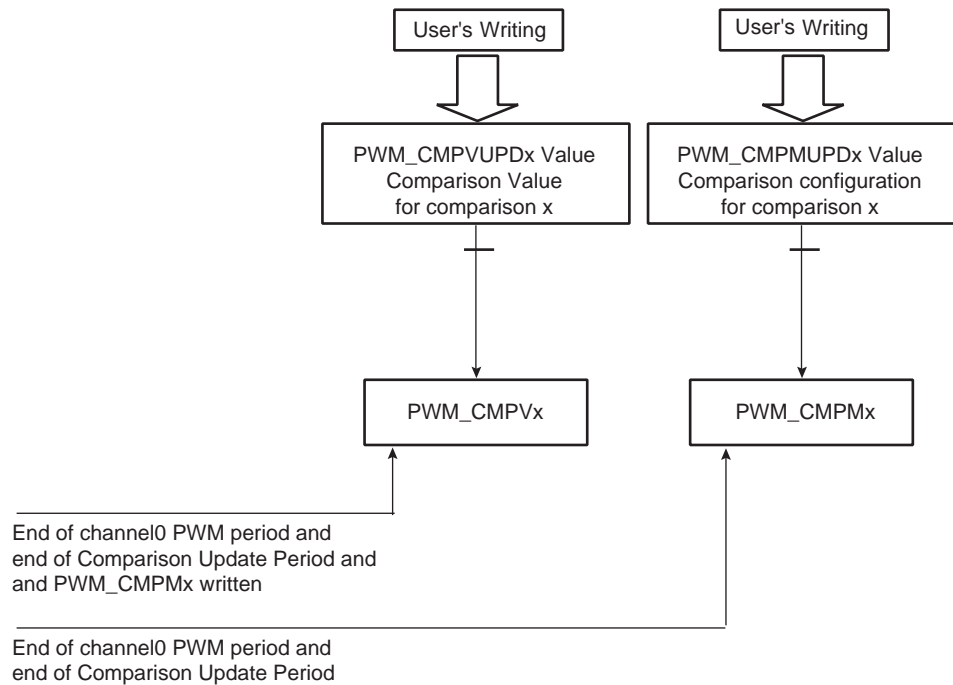

37.6.5.6 Interrupts

Depending on the interrupt mask in the PWM_IMR1 and PWM_IMR2 registers, an interrupt can be generated at the end of the corresponding channel period (CHIDx in the PWM_ISR1 register), after a fault event (FCHIDx in the PWM_ISR1 register), after a comparison match (CMPMx in the PWM_ISR2 register), after a comparison update (CMPUx in the PWM_ISR2 register) or according to the transfer mode of the synchronous channels (WRDY, ENDTX, TXBUFE and UNRE in the PWM_ISR2 register).

If the interrupt is generated by the flags CHIDx or FCHIDx, the interrupt remains active until a read operation in the PWM_ISR1 register occurs.

If the interrupt is generated by the flags WRDY or UNRE or CMPMx or CMPUx, the interrupt remains active until a read operation in the PWM_ISR2 register occurs.

A channel interrupt is enabled by setting the corresponding bit in the PWM_IER1 and PWM_IER2 registers. A channel interrupt is disabled by setting the corresponding bit in the PWM_IDR1 and PWM_IDR2 registers.

37.6.5.7 Write Protect Registers

To prevent any single software error that may corrupt PWM behavior, the registers listed below can be write-protected by writing the field WPCMD in the “PWM Write Protect Control Register” on page 963 (PWM_WPCR). They are divided into 6 groups:

- Register group 0:
 - “PWM Clock Register” on page 937
- Register group 1:
 - “PWM Disable Register” on page 938

- Register group 2:
 - “PWM Sync Channels Mode Register” on page 942
 - “PWM Channel Mode Register” on page 970
 - “PWM Stepper Motor Mode Register” on page 962
 -
- Register group 3:
 - “PWM Channel Period Register” on page 974
 - “PWM Channel Period Update Register” on page 975
- Register group 4:
 - “PWM Channel Dead Time Register” on page 977
 - “PWM Channel Dead Time Update Register” on page 978
- Register group 5:
 - “PWM Fault Mode Register” on page 956
 - “PWM Fault Protection Value Register” on page 959

There are two types of Write Protect:

- Write Protect SW, which can be enabled or disabled.
- Write Protect HW, which can just be enabled, only a hardware reset of the PWM controller can disable it.

Both types of Write Protect can be applied independently to a particular register group by means of the WPCMD and WPRG fields in PWM_WPCR register. If at least one Write Protect is active, the register group is write-protected. The field WPCMD allows to perform the following actions depending on its value:

- 0 = Disabling the Write Protect SW of the register groups of which the bit WPRG is at 1.
- 1 = Enabling the Write Protect SW of the register groups of which the bit WPRG is at 1.
- 2 = Enabling the Write Protect HW of the register groups of which the bit WPRG is at 1.

At any time, the user can determine which Write Protect is active in which register group by the fields WPSWS and WPHWS in the “PWM Write Protect Status Register” on page 965 (PWM_WPSR).

If a write access in a write-protected register is detected, then the WPVS flag in the PWM_WPSR register is set and the field WPVSRC indicates in which register the write access has been attempted, through its address offset without the two LSBs.

The WPVS and PWM_WPSR fields are automatically reset after reading the PWM_WPSR register.

37.7 Pulse Width Modulation Controller (PWM) Controller User Interface

Table 37-6. Register Mapping

Offset	Register	Name	Access	Reset
0x00	PWM Clock Register	PWM_CLK	Read-write	0x0
0x04	PWM Enable Register	PWM_ENA	Write-only	–
0x08	PWM Disable Register	PWM_DIS	Write-only	–
0x0C	PWM Status Register	PWM_SR	Read-only	0x0
0x10	PWM Interrupt Enable Register 1	PWM_IER1	Write-only	–
0x14	PWM Interrupt Disable Register 1	PWM_IDR1	Write-only	–
0x18	PWM Interrupt Mask Register 1	PWM_IMR1	Read-only	0x0
0x1C	PWM Interrupt Status Register 1	PWM_ISR1	Read-only	0x0
0x20	PWM Sync Channels Mode Register	PWM_SCM	Read-write	0x0
0x24	Reserved	–	–	–
0x28	PWM Sync Channels Update Control Register	PWM_SCUC	Read-write	0x0
0x2C	PWM Sync Channels Update Period Register	PWM_SCUP	Read-write	0x0
0x30	PWM Sync Channels Update Period Update Register	PWM_SCUPUPD	Write-only	0x0
0x34	PWM Interrupt Enable Register 2	PWM_IER2	Write-only	–
0x38	PWM Interrupt Disable Register 2	PWM_IDR2	Write-only	–
0x3C	PWM Interrupt Mask Register 2	PWM_IMR2	Read-only	0x0
0x40	PWM Interrupt Status Register 2	PWM_ISR2	Read-only	0x0
0x44	PWM Output Override Value Register	PWM_OOV	Read-write	0x0
0x48	PWM Output Selection Register	PWM_OS	Read-write	0x0
0x4C	PWM Output Selection Set Register	PWM_OSS	Write-only	–
0x50	PWM Output Selection Clear Register	PWM_OSC	Write-only	–
0x54	PWM Output Selection Set Update Register	PWM_OSSUPD	Write-only	–
0x58	PWM Output Selection Clear Update Register	PWM_OSCUPD	Write-only	–
0x5C	PWM Fault Mode Register	PWM_FMR	Read-write	0x0
0x60	PWM Fault Status Register	PWM_FSR	Read-only	0x0
0x64	PWM Fault Clear Register	PWM_FCR	Write-only	–
0x68	PWM Fault Protection Value Register	PWM_FPV	Read-write	0x0
0x6C	PWM Fault Protection Enable Register	PWM_FPE	Read-write	0x0
0x70-0x78	Reserved	–	–	–
0x7C	PWM Event Line 0 Mode Register	PWM_ELMR0	Read-write	0x0
0x80	PWM Event Line 1 Mode Register	PWM_ELMR1	Read-write	0x0
0x84-0x9C	Reserved	–	–	–
0xA0 - 0xAC	Reserved	–	–	–
0xB0	PWM Stepper Motor Mode Register	PWM_SMMR	Read-write	0x0

Table 37-6. Register Mapping (Continued)

Offset	Register	Name	Access	Reset
0xB4-0xBC	Reserved	–	–	–
0xC0-E0	Reserved	–	–	–
0xE4	PWM Write Protect Control Register	PWM_WPCR	Write-only	–
0xE8	PWM Write Protect Status Register	PWM_WPSR	Read-only	0x0
0xEC - 0xFC	Reserved	–	–	–
0x100 - 0x128	Reserved for PDC registers	–	–	–
0x12C	Reserved	–	–	–
0x130	PWM Comparison 0 Value Register	PWM_CMPV0	Read-write	0x0
0x134	PWM Comparison 0 Value Update Register	PWM_CMPVUPD0	Write-only	–
0x138	PWM Comparison 0 Mode Register	PWM_CMPM0	Read-write	0x0
0x13C	PWM Comparison 0 Mode Update Register	PWM_CMPMUPD0	Write-only	–
0x140	PWM Comparison 1 Value Register	PWM_CMPV1	Read-write	0x0
0x144	PWM Comparison 1 Value Update Register	PWM_CMPVUPD1	Write-only	–
0x148	PWM Comparison 1 Mode Register	PWM_CMPM1	Read-write	0x0
0x14C	PWM Comparison 1 Mode Update Register	PWM_CMPMUPD1	Write-only	–
0x150	PWM Comparison 2 Value Register	PWM_CMPV2	Read-write	0x0
0x154	PWM Comparison 2 Value Update Register	PWM_CMPVUPD2	Write-only	–
0x158	PWM Comparison 2 Mode Register	PWM_CMPM2	Read-write	0x0
0x15C	PWM Comparison 2 Mode Update Register	PWM_CMPMUPD2	Write-only	–
0x160	PWM Comparison 3 Value Register	PWM_CMPV3	Read-write	0x0
0x164	PWM Comparison 3 Value Update Register	PWM_CMPVUPD3	Write-only	–
0x168	PWM Comparison 3 Mode Register	PWM_CMPM3	Read-write	0x0
0x16C	PWM Comparison 3 Mode Update Register	PWM_CMPMUPD3	Write-only	–
0x170	PWM Comparison 4 Value Register	PWM_CMPV4	Read-write	0x0
0x174	PWM Comparison 4 Value Update Register	PWM_CMPVUPD4	Write-only	–
0x178	PWM Comparison 4 Mode Register	PWM_CMPM4	Read-write	0x0
0x17C	PWM Comparison 4 Mode Update Register	PWM_CMPMUPD4	Write-only	–
0x180	PWM Comparison 5 Value Register	PWM_CMPV5	Read-write	0x0
0x184	PWM Comparison 5 Value Update Register	PWM_CMPVUPD5	Write-only	–
0x188	PWM Comparison 5 Mode Register	PWM_CMPM5	Read-write	0x0
0x18C	PWM Comparison 5 Mode Update Register	PWM_CMPMUPD5	Write-only	–
0x190	PWM Comparison 6 Value Register	PWM_CMPV6	Read-write	0x0
0x194	PWM Comparison 6 Value Update Register	PWM_CMPVUPD6	Write-only	–
0x198	PWM Comparison 6 Mode Register	PWM_CMPM6	Read-write	0x0
0x19C	PWM Comparison 6 Mode Update Register	PWM_CMPMUPD6	Write-only	–
0x1A0	PWM Comparison 7 Value Register	PWM_CMPV7	Read-write	0x0



Table 37-6. Register Mapping (Continued)

Offset	Register	Name	Access	Reset
0x1A4	PWM Comparison 7 Value Update Register	PWM_CMPVUPD7	Write-only	–
0x1A8	PWM Comparison 7 Mode Register	PWM_CPM7	Read-write	0x0
0x1AC	PWM Comparison 7 Mode Update Register	PWM_CPMUPD7	Write-only	–
0x1B0 - 0x1FC	Reserved	–	–	–
0x200 + ch_num * 0x20 + 0x00	PWM Channel Mode Register ⁽¹⁾	PWM_CMR	Read-write	0x0
0x200 + ch_num * 0x20 + 0x04	PWM Channel Duty Cycle Register ⁽¹⁾	PWM_CDTY	Read-write	0x0
0x200 + ch_num * 0x20 + 0x08	PWM Channel Duty Cycle Update Register ⁽¹⁾	PWM_CDTYUPD	Write-only	–
0x200 + ch_num * 0x20 + 0x0C	PWM Channel Period Register ⁽¹⁾	PWM_CPRD	Read-write	0x0
0x200 + ch_num * 0x20 + 0x10	PWM Channel Period Update Register ⁽¹⁾	PWM_CPRDUPD	Write-only	–
0x200 + ch_num * 0x20 + 0x14	PWM Channel Counter Register ⁽¹⁾	PWM_CCNT	Read-only	0x0
0x200 + ch_num * 0x20 + 0x18	PWM Channel Dead Time Register ⁽¹⁾	PWM_DT	Read-write	0x0
0x200 + ch_num * 0x20 + 0x1C	PWM Channel Dead Time Update Register ⁽¹⁾	PWM_DTUPD	Write-only	–

Note: 1. Some registers are indexed with “ch_num” index ranging from 0 to 3.

37.7.1 PWM Clock Register

Name: PWM_CLK

Address: 0x40020000

Access: Read-write

31	30	29	28	27	26	25	24
-				PREB			
23	22	21	20	19	18	17	16
DIVB							
15	14	13	12	11	10	9	8
-				PREA			
7	6	5	4	3	2	1	0
DIVA							

This register can only be written if the bits WPSWS0 and WPHWS0 are cleared in “PWM Write Protect Status Register” on page 965.

- DIVA, DIVB: CLKA, CLKB Divide Factor**

DIVA, DIVB	CLKA, CLKB
0	CLKA, CLKB clock is turned off
1	CLKA, CLKB clock is clock selected by PREA, PREB
2-255	CLKA, CLKB clock is clock selected by PREA, PREB divided by DIVA, DIVB factor.

- PREA, PREB: CLKA, CLKB Source Clock Selection**

PREA, PREB				Divider Input Clock
0	0	0	0	MCK
0	0	0	1	MCK/2
0	0	1	0	MCK/4
0	0	1	1	MCK/8
0	1	0	0	MCK/16
0	1	0	1	MCK/32
0	1	1	0	MCK/64
0	1	1	1	MCK/128
1	0	0	0	MCK/256
1	0	0	1	MCK/512
1	0	1	0	MCK/1024
Other				Reserved

37.7.2 PWM Enable Register

Name: PWM_ENA
Address: 0x40020004
Access: Write-only

31	30	29	28	27	26	25	24
–	–	–	–	–	–	–	–
23	22	21	20	19	18	17	16
–	–	–	–	–	–	–	–
15	14	13	12	11	10	9	8
–	–	–	–	–	–	–	–
7	6	5	4	3	2	1	0
–	–	–	–	CHID3	CHID2	CHID1	CHID0

- **CHIDx: Channel ID**

0 = No effect.

1 = Enable PWM output for channel x.

37.7.3 PWM Disable Register

Name: PWM_DIS
Address: 0x40020008
Access: Write-only

31	30	29	28	27	26	25	24
–	–	–	–	–	–	–	–
23	22	21	20	19	18	17	16
–	–	–	–	–	–	–	–
15	14	13	12	11	10	9	8
–	–	–	–	–	–	–	–
7	6	5	4	3	2	1	0
–	–	–	–	CHID3	CHID2	CHID1	CHID0

This register can only be written if the bits WPSWS1 and WPHWS1 are cleared in “PWM Write Protect Status Register” on [page 965](#).

- **CHIDx: Channel ID**

0 = No effect.

1 = Disable PWM output for channel x.

37.7.4 PWM Status Register

Name: PWM_SR

Address: 0x4002000C

Access: Read-only

31	30	29	28	27	26	25	24
–	–	–	–	–	–	–	–
23	22	21	20	19	18	17	16
–	–	–	–	–	–	–	–
15	14	13	12	11	10	9	8
–	–	–	–	–	–	–	–
7	6	5	4	3	2	1	0
–	–	–	–	CHID3	CHID2	CHID1	CHID0

- **CHIDx: Channel ID**

0 = PWM output for channel x is disabled.

1 = PWM output for channel x is enabled.

37.7.5 PWM Interrupt Enable Register 1

Name: PWM_IER1

Address: 0x40020010

Access: Write-only

31	30	29	28	27	26	25	24
–	–	–	–	–	–	–	–
23	22	21	20	19	18	17	16
–	–	–	–	FCHID3	FCHID2	FCHID1	FCHID0
15	14	13	12	11	10	9	8
–	–	–	–	–	–	–	–
7	6	5	4	3	2	1	0
–	–	–	–	CHID3	CHID2	CHID1	CHID0

- **CHIDx: Counter Event on Channel x Interrupt Enable**

- **FCHIDx: Fault Protection Trigger on Channel x Interrupt Enable**

37.7.6 PWM Interrupt Disable Register 1

Name: PWM_IDR1
Address: 0x40020014
Access: Write-only

31	30	29	28	27	26	25	24
–	–	–	–	–	–	–	–
23	22	21	20	19	18	17	16
–	–	–	–	FCHID3	FCHID2	FCHID1	FCHID0
15	14	13	12	11	10	9	8
–	–	–	–	–	–	–	–
7	6	5	4	3	2	1	0
–	–	–	–	CHID3	CHID2	CHID1	CHID0

- **CHIDx: Counter Event on Channel x Interrupt Disable**
- **FCHIDx: Fault Protection Trigger on Channel x Interrupt Disable**

37.7.7 PWM Interrupt Mask Register 1

Name: PWM_IMR1
Address: 0x40020018
Access: Read-only

31	30	29	28	27	26	25	24
–	–	–	–	–	–	–	–
23	22	21	20	19	18	17	16
–	–	–	–	FCHID3	FCHID2	FCHID1	FCHID0
15	14	13	12	11	10	9	8
–	–	–	–	–	–	–	–
7	6	5	4	3	2	1	0
–	–	–	–	CHID3	CHID2	CHID1	CHID0

- **CHIDx: Counter Event on Channel x Interrupt Mask**
- **FCHIDx: Fault Protection Trigger on Channel x Interrupt Mask**

37.7.8 PWM Interrupt Status Register 1

Name: PWM_ISR1
Address: 0x4002001C
Access: Read-only

31	30	29	28	27	26	25	24
–	–	–	–	–	–	–	–
23	22	21	20	19	18	17	16
–	–	–	–	FCHID3	FCHID2	FCHID1	FCHID0
15	14	13	12	11	10	9	8
–	–	–	–	–	–	–	–
7	6	5	4	3	2	1	0
–	–	–	–	CHID3	CHID2	CHID1	CHID0

- **CHIDx: Counter Event on Channel x**

0 = No new counter event has occurred since the last read of the PWM_ISR1 register.

1 = At least one counter event has occurred since the last read of the PWM_ISR1 register.

- **FCHIDx: Fault Protection Trigger on Channel x**

0 = No new trigger of the fault protection since the last read of the PWM_ISR1 register.

1 = At least one trigger of the fault protection since the last read of the PWM_ISR1 register.

Note: Reading PWM_ISR1 automatically clears CHIDx and FCHIDx flags.

37.7.9 PWM Sync Channels Mode Register

Name: PWM_SCM
Address: 0x40020020
Access: Read-write

31	30	29	28	27	26	25	24
–	–	–	–	–	–	–	–
23	22	21	20	19	18	17	16
PTRCS			PTRM	–	–	UPDM	
15	14	13	12	11	10	9	8
–	–	–	–	–	–	–	–
7	6	5	4	3	2	1	0
–	–	–	–	SYNC3	SYNC2	SYNC1	SYNC0

This register can only be written if the bits WPSWS2 and WPHWS2 are cleared in “PWM Write Protect Status Register” on page 965.

- **SYNCx: Synchronous Channel x**

0 = Channel x is not a synchronous channel.

1 = Channel x is a synchronous channel.

- **UPDM: Synchronous Channels Update Mode**

Value	Name	Description
0	MODE0	Manual write of double buffer registers and manual update of synchronous channels ⁽¹⁾
1	MODE1	Manual write of double buffer registers and automatic update of synchronous channels ⁽²⁾
2	MODE2	Automatic write of duty-cycle update registers by the PDC and automatic update of synchronous channels ⁽²⁾
3	–	Reserved

Notes: 1. The update occurs at the beginning of the next PWM period, when the UPDULOCK bit in “PWM Sync Channels Update Control Register” is set.

2. The update occurs when the Update Period is elapsed.

- **PTRM: PDCDMA Transfer Request Mode**

UPDM	PTRM	WRDY Flag and PDC Transfer Request
0	x	The WRDY flag in “PWM Interrupt Status Register 2” on page 949 and the PDC transfer request are never set to 1.
1	x	The WRDY flag in “PWM Interrupt Status Register 2” on page 949 is set to 1 as soon as the update period is elapsed, the PDC transfer request is never set to 1.
2	0	The WRDY flag in “PWM Interrupt Status Register 2” on page 949 and the PDC transfer request are set to 1 as soon as the update period is elapsed.
	1	The WRDY flag in “PWM Interrupt Status Register 2” on page 949 and the PDC transfer request are set to 1 as soon as the selected comparison matches.

- **PTRCS: PDCDMA Transfer Request Comparison Selection**

Selection of the comparison used to set the flag WRDY and the corresponding PDC transfer request.

37.7.10 PWM Sync Channels Update Control Register

Name: PWM_SCUC

Address: 0x40020028

Access: Read-write

31	30	29	28	27	26	25	24
–	–	–	–	–	–	–	–
23	22	21	20	19	18	17	16
–	–	–	–	–	–	–	–
15	14	13	12	11	10	9	8
–	–	–	–	–	–	–	–
7	6	5	4	3	2	1	0
–	–	–	–	–	–	–	UPDULOCK

- **UPDULOCK: Synchronous Channels Update Unlock**

0 = No effect

1 = If the UPDM field is set to “0” in [“PWM Sync Channels Mode Register” on page 942](#), writing the UPDULOCK bit to “1” triggers the update of the period value, the duty-cycle and the dead-time values of synchronous channels at the beginning of the next PWM period. If the field UPDM is set to “1” or “2”, writing the UPDULOCK bit to “1” triggers only the update of the period value and of the dead-time values of synchronous channels.

This bit is automatically reset when the update is done.

37.7.11 PWM Sync Channels Update Period Register

Name: PWM_SCUP

Address: 0x4002002C

Access: Read-write

31	30	29	28	27	26	25	24
–	–	–	–	–	–	–	–
23	22	21	20	19	18	17	16
–	–	–	–	–	–	–	–
15	14	13	12	11	10	9	8
–	–	–	–	–	–	–	–
7	6	5	4	3	2	1	0
UPRCNT				UPR			

- **UPR: Update Period**

Defines the time between each update of the synchronous channels if automatic trigger of the update is activated (UPDM = 1 or UPDM = 2 in “[PWM Sync Channels Mode Register](#)” on page 942). This time is equal to UPR+1 periods of the synchronous channels.

- **UPRCNT: Update Period Counter**

Reports the value of the Update Period Counter.

37.7.12 PWM Sync Channels Update Period Update Register

Name: PWM_SCUPUPD

Address: 0x40020030

Access: Write-only

31	30	29	28	27	26	25	24
–	–	–	–	–	–	–	–
23	22	21	20	19	18	17	16
–	–	–	–	–	–	–	–
15	14	13	12	11	10	9	8
–	–	–	–	–	–	–	–
7	6	5	4	3	2	1	0
–	–	–	–	UPRUPD			

This register acts as a double buffer for the UPR value. This prevents an unexpected automatic trigger of the update of synchronous channels.

- **UPRUPD: Update Period Update**

Defines the wanted time between each update of the synchronous channels if automatic trigger of the update is activated (UPDM = 1 or UPDM = 2 in “[PWM Sync Channels Mode Register](#)” on page 942). This time is equal to UPR+1 periods of the synchronous channels.

37.7.13 PWM Interrupt Enable Register 2

Name: PWM_IER2

Address: 0x40020034

Access: Write-only

31	30	29	28	27	26	25	24
–	–	–	–	–	–	–	–
23	22	21	20	19	18	17	16
CMPU7	CMPU6	CMPU5	CMPU4	CMPU3	CMPU2	CMPU1	CMPU0
15	14	13	12	11	10	9	8
CMPM7	CMPM6	CMPM5	CMPM4	CMPM3	CMPM2	CMPM1	CMPM0
7	6	5	4	3	2	1	0
–	–	–	–	UNRE	TXBUFE	ENDTX	WRDY

- **WRDY:** Write Ready for Synchronous Channels Update Interrupt Enable
- **ENDTX:** PDC End of TX Buffer Interrupt Enable
- **TXBUFE:** PDC TX Buffer Empty Interrupt Enable
- **UNRE:** Synchronous Channels Update Underrun Error Interrupt Enable
- **CMPMx:** Comparison x Match Interrupt Enable
- **CMPUx:** Comparison x Update Interrupt Enable

37.7.14 PWM Interrupt Disable Register 2

Name: PWM_IDR2

Address: 0x40020038

Access: Write-only

31	30	29	28	27	26	25	24
–	–	–	–	–	–	–	–
23	22	21	20	19	18	17	16
CMPU7	CMPU6	CMPU5	CMPU4	CMPU3	CMPU2	CMPU1	CMPU0
15	14	13	12	11	10	9	8
CMPM7	CMPM6	CMPM5	CMPM4	CMPM3	CMPM2	CMPM1	CMPM0
7	6	5	4	3	2	1	0
–	–	–	–	UNRE	TXBUFE	ENDTX	WRDY

- **WRDY:** Write Ready for Synchronous Channels Update Interrupt Disable
- **ENDTX:** PDC End of TX Buffer Interrupt Disable
- **TXBUFE:** PDC TX Buffer Empty Interrupt Disable
- **UNRE:** Synchronous Channels Update Underrun Error Interrupt Disable
- **CMPMx:** Comparison x Match Interrupt Disable
- **CMPUx:** Comparison x Update Interrupt Disable

37.7.15 PWM Interrupt Mask Register 2

Name: PWM_IMR2

Address: 0x4002003C

Access: Read-only

31	30	29	28	27	26	25	24
–	–	–	–	–	–	–	–
23	22	21	20	19	18	17	16
CMPU7	CMPU6	CMPU5	CMPU4	CMPU3	CMPU2	CMPU1	CMPU0
15	14	13	12	11	10	9	8
CMPM7	CMPM6	CMPM5	CMPM4	CMPM3	CMPM2	CMPM1	CMPM0
7	6	5	4	3	2	1	0
–	–	–	–	UNRE	TXBUFE	ENDTX	WRDY

- **WRDY:** Write Ready for Synchronous Channels Update Interrupt Mask
- **ENDTX:** PDC End of TX Buffer Interrupt Mask
- **TXBUFE:** PDC TX Buffer Empty Interrupt Mask
- **UNRE:** Synchronous Channels Update Underrun Error Interrupt Mask
- **CMPMx:** Comparison x Match Interrupt Mask
- **CMPUx:** Comparison x Update Interrupt Mask

37.7.16 PWM Interrupt Status Register 2

Name: PWM_ISR2
Address: 0x40020040
Access: Read-only

31	30	29	28	27	26	25	24
–	–	–	–	–	–	–	–
23	22	21	20	19	18	17	16
CMPU7	CMPU6	CMPU5	CMPU4	CMPU3	CMPU2	CMPU1	CMPU0
15	14	13	12	11	10	9	8
CMPM7	CMPM6	CMPM5	CMPM4	CMPM3	CMPM2	CMPM1	CMPM0
7	6	5	4	3	2	1	0
–	–	–	–	UNRE	TXBUFE	ENDTX	WRDY

- **WRDY: Write Ready for Synchronous Channels Update**
 0 = New duty-cycle and dead-time values for the synchronous channels cannot be written.
 1 = New duty-cycle and dead-time values for the synchronous channels can be written.
- **ENDTX: PDC End of TX Buffer**
 0 = The Transmit Counter register has not reached 0 since the last write of the PDC.
 1 = The Transmit Counter register has reached 0 since the last write of the PDC.
- **TXBUFE: PDC TX Buffer Empty**
 0 = PWM_TCR or PWM_TCNR has a value other than 0.
 1 = Both PWM_TCR and PWM_TCNR have a value other than 0.
- **UNRE: Synchronous Channels Update Underrun Error**
 0 = No Synchronous Channels Update Underrun has occurred since the last read of the PWM_ISR2 register.
 1 = At least one Synchronous Channels Update Underrun has occurred since the last read of the PWM_ISR2 register.
- **CMPMx: Comparison x Match**
 0 = The comparison x has not matched since the last read of the PWM_ISR2 register.
 1 = The comparison x has matched at least one time since the last read of the PWM_ISR2 register.
- **CMPUx: Comparison x Update**
 0 = The comparison x has not been updated since the last read of the PWM_ISR2 register.
 1 = The comparison x has been updated at least one time since the last read of the PWM_ISR2 register.

Note: Reading PWM_ISR2 automatically clears flags WRDY, UNRE and CMPSx.

37.7.17 PWM Output Override Value Register

Name: PWM_OOV

Address: 0x40020044

Access: Read-write

31	30	29	28	27	26	25	24
–	–	–	–	–	–	–	–
23	22	21	20	19	18	17	16
–	–	–	–	OOVL3	OOVL2	OOVL1	OOVL0
15	14	13	12	11	10	9	8
–	–	–	–	–	–	–	–
7	6	5	4	3	2	1	0
–	–	–	–	OOVH3	OOVH2	OOVH1	OOVH0

- **OOVHx: Output Override Value for PWMH output of the channel x**

0 = Override value is 0 for PWMH output of channel x.

1 = Override value is 1 for PWMH output of channel x.

- **OOVLx: Output Override Value for PWML output of the channel x**

0 = Override value is 0 for PWML output of channel x.

1 = Override value is 1 for PWML output of channel x.

37.7.18 PWM Output Selection Register

Name: PWM_OS

Address: 0x40020048

Access: Read-write

31	30	29	28	27	26	25	24
–	–	–	–	–	–	–	–
23	22	21	20	19	18	17	16
–	–	–	–	OSL3	OSL2	OSL1	OSL0
15	14	13	12	11	10	9	8
–	–	–	–	–	–	–	–
7	6	5	4	3	2	1	0
–	–	–	–	OSH3	OSH2	OSH1	OSH0

- **OSHx: Output Selection for PWMH output of the channel x**

0 = Dead-time generator output DTOHx selected as PWMH output of channel x.

1 = Output override value OOVHx selected as PWMH output of channel x.

- **OSLx: Output Selection for PWML output of the channel x**

0 = Dead-time generator output DTOLx selected as PWML output of channel x.

1 = Output override value OOVLx selected as PWML output of channel x.

37.7.19 PWM Output Selection Set Register

Name: PWM_OSS

Address: 0x4002004C

Access: Write-only

31	30	29	28	27	26	25	24
–	–	–	–	–	–	–	–
23	22	21	20	19	18	17	16
–	–	–	–	OSSL3	OSSL2	OSSL1	OSSL0
15	14	13	12	11	10	9	8
–	–	–	–	–	–	–	–
7	6	5	4	3	2	1	0
–	–	–	–	OSSH3	OSSH2	OSSH1	OSSH0

- **OSSHx: Output Selection Set for PWMH output of the channel x**

0 = No effect.

1 = Output override value OOVHx selected as PWMH output of channel x.

- **OSSLx: Output Selection Set for PWML output of the channel x**

0 = No effect.

1 = Output override value OOVLx selected as PWML output of channel x.

37.7.20 PWM Output Selection Clear Register

Name: PWM_OSC

Address: 0x40020050

Access: Write-only

31	30	29	28	27	26	25	24
–	–	–	–	–	–	–	–
23	22	21	20	19	18	17	16
–	–	–	–	OSCL3	OSCL2	OSCL1	OSCL0
15	14	13	12	11	10	9	8
–	–	–	–	–	–	–	–
7	6	5	4	3	2	1	0
–	–	–	–	OSCH3	OSCH2	OSCH1	OSCH0

- **OSCHx: Output Selection Clear for PWMH output of the channel x**

0 = No effect.

1 = Dead-time generator output DTOHx selected as PWMH output of channel x.

- **OSCLx: Output Selection Clear for PWML output of the channel x**

0 = No effect.

1 = Dead-time generator output DTOLx selected as PWML output of channel x.

37.7.21 PWM Output Selection Set Update Register

Name: PWM_OSSUPD

Address: 0x40020054

Access: Write-only

31	30	29	28	27	26	25	24
–	–	–	–	–	–	–	–
23	22	21	20	19	18	17	16
–	–	–	–	OSSUPL3	OSSUPL2	OSSUPL1	OSSUPL0
15	14	13	12	11	10	9	8
–	–	–	–	–	–	–	–
7	6	5	4	3	2	1	0
–	–	–	–	OSSUPH3	OSSUPH2	OSSUPH1	OSSUPH0

- **OSSUPHx: Output Selection Set for PWMH output of the channel x**

0 = No effect.

1 = Output override value OOVHx selected as PWMH output of channel x at the beginning of the next channel x PWM period.

- **OSSUPLx: Output Selection Set for PWML output of the channel x**

0 = No effect.

1 = Output override value OOVLx selected as PWML output of channel x at the beginning of the next channel x PWM period.

37.7.22 PWM Output Selection Clear Update Register

Name: PWM_OSCUPD

Address: 0x40020058

Access: Write-only

31	30	29	28	27	26	25	24
–	–	–	–	–	–	–	–
23	22	21	20	19	18	17	16
–	–	–	–	OSCUPL3	OSCUPL2	OSCUPL1	OSCUPL0
15	14	13	12	11	10	9	8
–	–	–	–	–	–	–	–
7	6	5	4	3	2	1	0
–	–	–	–	OSCUPL3	OSCUPL2	OSCUPL1	OSCUPL0

- **OSCUPLx: Output Selection Clear for PWML output of the channel x**

0 = No effect.

1 = Dead-time generator output DTOHx selected as PWML output of channel x at the beginning of the next channel x PWM period.

- **OSCUPLx: Output Selection Clear for PWMH output of the channel x**

0 = No effect.

1 = Dead-time generator output DTOLx selected as PWMH output of channel x at the beginning of the next channel x PWM period.

37.7.23 PWM Fault Mode Register

Name: PWM_FMR
Address: 0x4002005C
Access: Read-write

31	30	29	28	27	26	25	24
-							
23	22	21	20	19	18	17	16
FFIL							
15	14	13	12	11	10	9	8
FMOD							
7	6	5	4	3	2	1	0
FPOL							

This register can only be written if the bits WPSWS5 and WPHWS5 are cleared in “PWM Write Protect Status Register” on page 965.

- **FPOL: Fault Polarity (fault input bit varies from 0 to 5)**

For each field bit y (fault input number):

- 0 = The fault y becomes active when the fault input y is at 0.
- 1 = The fault y becomes active when the fault input y is at 1.

- **FMOD: Fault Activation Mode (fault input bit varies from 0 to 5)**

For each field bit y (fault input number):

- 0 = The fault y is active until the Fault condition is removed at the peripheral⁽¹⁾ level.
- 1 = The fault y stays active until the Fault condition is removed at the peripheral⁽¹⁾ level AND until it is cleared in the “PWM Fault Clear Register” .

Note: 1. The Peripheral generating the fault.

- **FFIL: Fault Filtering (fault input bit varies from 0 to 5)**

For each field bit y (fault input number):

- 0 = The fault input y is not filtered.
- 1 = The fault input y is filtered.

CAUTION: To prevent an unexpected activation of the status flag FSy in the “PWM Fault Status Register” on page 957, the bit FMODEy can be set to “1” only if the FPOLy bit has been previously configured to its final value.

37.7.24 PWM Fault Status Register

Name: PWM_FSR

Address: 0x40020060

Access: Read-only

31	30	29	28	27	26	25	24
-							
23	22	21	20	19	18	17	16
-							
15	14	13	12	11	10	9	8
FS							
7	6	5	4	3	2	1	0
FIV							

- **FIV: Fault Input Value (fault input bit varies from 0 to 5)**

For each field bit y (fault input number):

- 0 = The current sampled value of the fault input y is 0 (after filtering if enabled).
- 1 = The current sampled value of the fault input y is 1 (after filtering if enabled).

- **FS: Fault Status (fault input bit varies from 0 to 5)**

For each field bit y (fault input number):

- 0 = The fault y is not currently active.
- 1 = The fault y is currently active.

37.7.25 PWM Fault Clear Register

Name: PWM_FCR

Address: 0x40020064

Access: Write-only

31	30	29	28	27	26	25	24
-							
23	22	21	20	19	18	17	16
-							
15	14	13	12	11	10	9	8
-							
7	6	5	4	3	2	1	0
FCLR							

- **FCLR: Fault Clear (fault input bit varies from 0 to 5)**

For each field bit y (fault input number):

0 = No effect.

1 = If bit y of FMODE field is set to 1 and if the fault input y is not at the level defined by the bit y of FPOL field, the fault y is cleared and becomes inactive (FMODE and FPOL fields belong to [“PWM Fault Mode Register” on page 956](#)), else writing this bit to 1 has no effect.

37.7.26 PWM Fault Protection Value Register

Name: PWM_FPV
Address: 0x40020068
Access: Read-write

31	30	29	28	27	26	25	24
–	–	–	–	–	–	–	–
23	22	21	20	19	18	17	16
–	–	–	–	FPVL3	FPVL2	FPVL1	FPVL0
15	14	13	12	11	10	9	8
–	–	–	–	–	–	–	–
7	6	5	4	3	2	1	0
–	–	–	–	FPVH3	FPVH2	FPVH1	FPVH0

This register can only be written if the bits WPSWS5 and WPHWS5 are cleared in “PWM Write Protect Status Register” on [page 965](#).

- **FPVHx: Fault Protection Value for PWMH output on channel x**

0 = PWMH output of channel x is forced to 0 when fault occurs.

1 = PWMH output of channel x is forced to 1 when fault occurs.

- **FPVLx: Fault Protection Value for PWML output on channel x**

0 = PWML output of channel x is forced to 0 when fault occurs.

1 = PWML output of channel x is forced to 1 when fault occurs.

37.7.27 PWM Fault Protection Enable Register

Name: PWM_FPE
Address: 0x4002006C
Access: Read-write

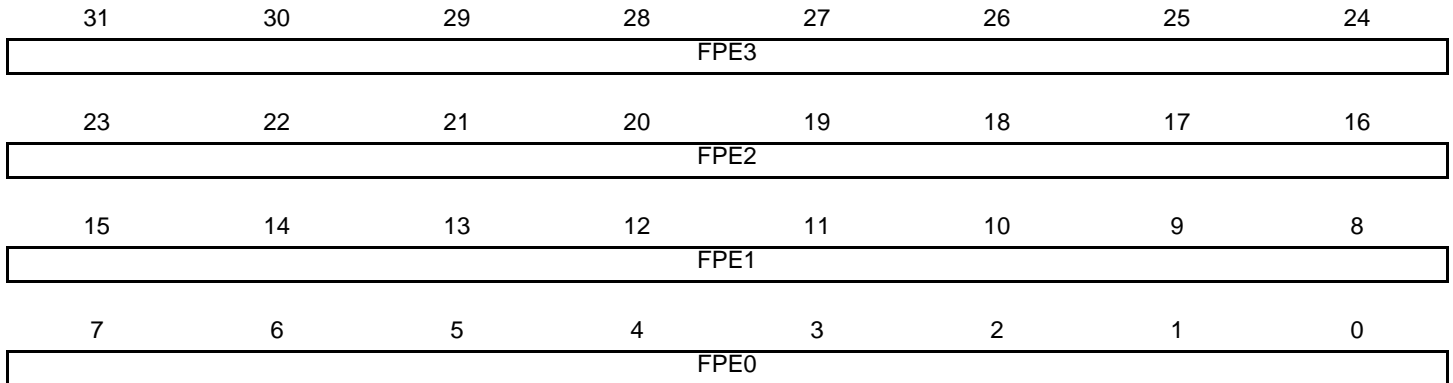

This register can only be written if the bits WPSWS5 and WPHWS5 are cleared in [“PWM Write Protect Status Register” on page 965](#).

Only the first 6 bits (number of fault input pins) of fields FPE0, FPE1, FPE2 and FPE3 are significant.

- **FPE_x: Fault Protection Enable for channel x (fault input bit varies from 0 to 5)**

For each field bit y (fault input number):

- 0 = Fault y is not used for the Fault Protection of channel x.
- 1 = Fault y is used for the Fault Protection of channel x.

CAUTION: To prevent an unexpected activation of the Fault Protection, the bit y of FPE_x field can be set to “1” only if the corresponding FPOL bit has been previously configured to its final value in [“PWM Fault Mode Register” on page 956](#).

37.7.28 PWM Event Line x Register

Name: PWM_ELMRx

Address: 0x4002007C

Access: Read-write

31	30	29	28	27	26	25	24
–	–	–	–	–	–	–	–
23	22	21	20	19	18	17	16
–	–	–	–	–	–	–	–
15	14	13	12	11	10	9	8
–	–	–	–	–	–	–	–
7	6	5	4	3	2	1	0
CSEL7	CSEL6	CSEL5	CSEL4	CSEL3	CSEL2	CSEL1	CSEL0

- **CSELy: Comparison y Selection**

0 = A pulse is not generated on the event line x when the comparison y matches.

1 = A pulse is generated on the event line x when the comparison y match.

37.7.29 PWM Stepper Motor Mode Register

Name: PWM_SMMR

Address: 0x400200B0

Access: Read-write

31	30	29	28	27	26	25	24
–	–	–	–	–	–	–	–
23	22	21	20	19	18	17	16
–	–	–	–	–	–	DOWN1	DOWN0
15	14	13	12	11	10	9	8
–	–	–	–	–	–	–	–
7	6	5	4	3	2	1	0
–	–	–	–	–	–	GCEN1	GCEN0

- **GCENx: Gray Count ENable**

0 = Disable gray count generation on PWML[2*x], PWMH[2*x], PWML[2*x +1], PWMH[2*x +1]

1 = enable gray count generation on PWML[2*x], PWMH[2*x], PWML[2*x +1], PWMH[2*x +1].

- **DOWNx: DOWN Count**

0 = Up counter.

1 = Down counter.

37.7.30 PWM Write Protect Control Register

Name: PWM_WPCR

Address: 0x400200E4

Access: Write-only

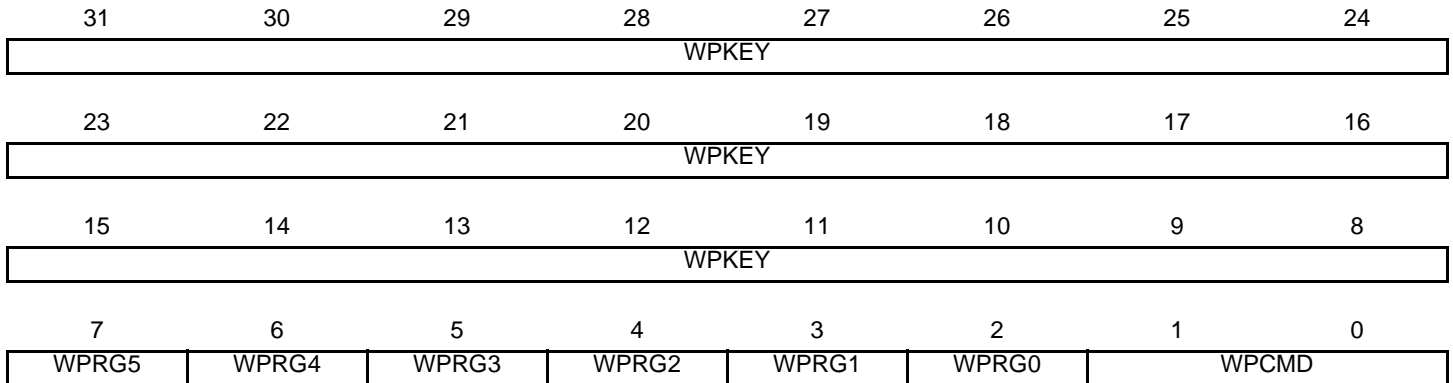

• **WPCMD: Write Protect Command**

This command is performed only if the WPKEY value is correct.

- 0 = Disable the Write Protect SW of the register groups of which the bit WPRGx is at 1.
- 1 = Enable the Write Protect SW of the register groups of which the bit WPRGx is at 1.
- 2 = Enable the Write Protect HW of the register groups of which the bit WPRGx is at 1.

Moreover, to meet security requirements, in this mode of operation, the PIO lines associated with PWM can not be configured through the PIO interface, not even by the PIO controller.

3 = No effect.

Note: Only a hardware reset of the PWM controller can disable the Write Protect HW.

• **WPRGx: Write Protect Register Group x**

- 0 = The WPCMD command has no effect on the register group x.
- 1 = The WPCMD command is applied to the register group x.

• **WPKEY: Write Protect Key**

Should be written at value 0x50574D (“PWM” in ASCII). Writing any other value in this field aborts the write operation of the WPCMD field. Always reads as 0.

List of register groups:

- Register group 0:
 - [“PWM Clock Register” on page 937](#)
- Register group 1:
 - [“PWM Disable Register” on page 938](#)
- Register group 2:
 - [“PWM Sync Channels Mode Register” on page 942](#)
 - [“PWM Channel Mode Register” on page 970](#)
 - [“PWM Stepper Motor Mode Register” on page 962](#)

- Register group 3:
 - “PWM Channel Period Register” on page 974
 - “PWM Channel Period Update Register” on page 975
- Register group 4:
 - “PWM Channel Dead Time Register” on page 977
 - “PWM Channel Dead Time Update Register” on page 978
- Register group 5:
 - “PWM Fault Mode Register” on page 956
 - “PWM Fault Protection Value Register” on page 959

37.7.31 PWM Write Protect Status Register

Name: PWM_WPSR

Address: 0x400200E8

Access: Read-only

31	30	29	28	27	26	25	24
WPVSR							
23	22	21	20	19	18	17	16
WPVSR							
15	14	13	12	11	10	9	8
-	-	WPHWS5	WPHWS4	WPHWS3	WPHWS2	WPHWS1	WPHWS0
7	6	5	4	3	2	1	0
WPVS	-	WPSWS5	WPSWS4	WPSWS3	WPSWS2	WPSWS1	WPSWS0

- **WPSWSx: Write Protect SW Status**

0 = The Write Protect SW x of the register group x is disabled.

1 = The Write Protect SW x of the register group x is enabled.

- **WPHWSx: Write Protect HW Status**

0 = The Write Protect HW x of the register group x is disabled.

1 = The Write Protect HW x of the register group x is enabled.

- **WPVS: Write Protect Violation Status**

0 = No Write Protect violation has occurred since the last read of the PWM_WPSR register.

1 = At least one Write Protect violation has occurred since the last read of the PWM_WPSR register. If this violation is an unauthorized attempt to write a protected register, the associated violation is reported into field WPVSR.

- **WPVSR: Write Protect Violation Source**

When WPVS is active, this field indicates the write-protected register (through address offset) in which a write access has been attempted.

Note: The two LSBs of the address offset of the write-protected register are not reported

Note: Reading PWM_WPSR automatically clears WPVS and WPVSR fields.

37.7.32 PWM Comparison x Value Register

Name: PWM_CMPVx

Address: 0x40020130 [0], 0x40020140 [1], 0x40020150 [2], 0x40020160 [3], 0x40020170 [4], 0x40020180 [5],
0x40020190 [6], 0x400201A0 [7]

Access: Read-write

31	30	29	28	27	26	25	24
–	–	–	–	–	–	–	CVM
23	22	21	20	19	18	17	16
CV							
15	14	13	12	11	10	9	8
CV							
7	6	5	4	3	2	1	0
CV							

Only the first 16 bits (channel counter size) of field CV are significant.

- **CV: Comparison x Value**

Define the comparison x value to be compared with the counter of the channel 0.

- **CVM: Comparison x Value Mode**

0 = The comparison x between the counter of the channel 0 and the comparison x value is performed when this counter is incrementing.

1 = The comparison x between the counter of the channel 0 and the comparison x value is performed when this counter is decrementing.

Note: This bit is useless if the counter of the channel 0 is left aligned (CALG = 0 in [“PWM Channel Mode Register” on page 970](#))

37.7.33 PWM Comparison x Value Update Register

Name: PWM_CMPVUPDx

Address: 0x40020134 [0], 0x40020144 [1], 0x40020154 [2], 0x40020164 [3], 0x40020174 [4], 0x40020184 [5],
0x40020194 [6], 0x400201A4 [7]

Access: Write-only

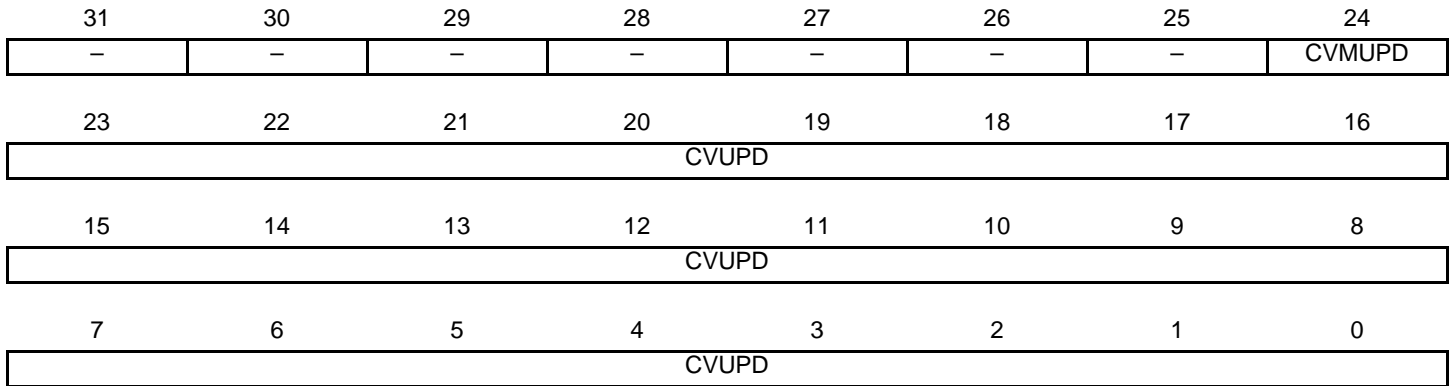

This register acts as a double buffer for the CV and CVM values. This prevents an unexpected comparison x match.

Only the first 16 bits (channel counter size) of field CVUPD are significant.

- **CVUPD: Comparison x Value Update**

Define the comparison x value to be compared with the counter of the channel 0.

- **CVMUPD: Comparison x Value Mode Update**

0 = The comparison x between the counter of the channel 0 and the comparison x value is performed when this counter is incrementing.

1 = The comparison x between the counter of the channel 0 and the comparison x value is performed when this counter is decrementing.

Note: This bit is useless if the counter of the channel 0 is left aligned (CALG = 0 in [“PWM Channel Mode Register” on page 970](#))

CAUTION: to be taken into account, the write of the register PWM_CMPVUPDx must be followed by a write of the register PWM_CMPMUPDx.

37.7.34 PWM Comparison x Mode Register

Name: PWM_CMPMx

Address: 0x40020138 [0], 0x40020148 [1], 0x40020158 [2], 0x40020168 [3], 0x40020178 [4], 0x40020188 [5],
0x40020198 [6], 0x400201A8 [7]

Access: Read-write

31	30	29	28	27	26	25	24
–	–	–	–	–	–	–	–
23	22	21	20	19	18	17	16
CUPRCNT				CUPR			
15	14	13	12	11	10	9	8
CPRCNT				CPR			
7	6	5	4	3	2	1	0
CTR				–	–	–	CEN

- **CEN: Comparison x Enable**

0 = The comparison x is disabled and can not match.

1 = The comparison x is enabled and can match.

- **CTR: Comparison x Trigger**

The comparison x is performed when the value of the comparison x period counter (CPRCNT) reaches the value defined by CTR.

- **CPR: Comparison x Period**

CPR defines the maximum value of the comparison x period counter (CPRCNT). The comparison x value is performed periodically once every CPR+1 periods of the channel 0 counter.

- **CPRCNT: Comparison x Period Counter**

Reports the value of the comparison x period counter.

Note: The field CPRCNT is read-only

- **CUPR: Comparison x Update Period**

Defines the time between each update of the comparison x mode and the comparison x value. This time is equal to CUPR+1 periods of the channel 0 counter.

- **CUPRCNT: Comparison x Update Period Counter**

Reports the value of the comparison x update period counter.

Note: The field CUPRCNT is read-only

37.7.35 PWM Comparison x Mode Update Register

Name: PWM_CMPMUPDx

Address: 0x4002013C [0], 0x4002014C [1], 0x4002015C [2], 0x4002016C [3], 0x4002017C [4], 0x4002018C [5],
0x4002019C [6], 0x400201AC [7]

Access: Write-only

31	30	29	28	27	26	25	24
–	–	–	–	–	–	–	–
23	22	21	20	19	18	17	16
–	–	–	–	CUPRUPD			
15	14	13	12	11	10	9	8
–	–	–	–	CPRUPD			
7	6	5	4	3	2	1	0
CTRUPD				–	–	–	CENUPD

This register acts as a double buffer for the CEN, CTR, CPR and CUPR values. This prevents an unexpected comparison x match.

- **CENUPD: Comparison x Enable Update**

0 = The comparison x is disabled and can not match.

1 = The comparison x is enabled and can match.

- **CTRUPD: Comparison x Trigger Update**

The comparison x is performed when the value of the comparison x period counter (CPRCNT) reaches the value defined by CTR.

- **CPRUPD: Comparison x Period Update**

CPR defines the maximum value of the comparison x period counter (CPRCNT). The comparison x value is performed periodically once every CPR+1 periods of the channel 0 counter.

- **CUPRUPD: Comparison x Update Period Update**

Defines the time between each update of the comparison x mode and the comparison x value. This time is equal to CUPR+1 periods of the channel 0 counter.



37.7.36 PWM Channel Mode Register

Name: PWM_CMRx [x=0..3]

Address: 0x40020200 [0], 0x40020220 [1], 0x40020240 [2], 0x40020260 [3]

Access: Read-write

31	30	29	28	27	26	25	24
–	–	–	–	–	–	–	–
23	22	21	20	19	18	17	16
–	–	–	–	–	DTLI	DTHI	DTE
15	14	13	12	11	10	9	8
–	–	–	–	–	CES	CPOL	CALG
7	6	5	4	3	2	1	0
–	–	–	–			CPRE	

This register can only be written if the bits WPSWS2 and WPHWS2 are cleared in “PWM Write Protect Status Register” on page 965.

• **CPRE: Channel Pre-scaler**

Value	Name	Description
0b0000	MCK	Master clock
0b0001	MCK_DIV_2	Master clock/2
0b0010	MCK_DIV_4	Master clock/4
0b0011	MCK_DIV_8	Master clock/8
0b0100	MCK_DIV_16	Master clock/16
0b0101	MCK_DIV_32	Master clock/32
0b0110	MCK_DIV_64	Master clock/64
0b0111	MCK_DIV_128	Master clock/128
0b1000	MCK_DIV_256	Master clock/256
0b1001	MCK_DIV_512	Master clock/512
0b1010	MCK_DIV_1024	Master clock/1024
0b1011	CLKA	Clock A
0b1100	CLKB	Clock B

• **CALG: Channel Alignment**

0 = The period is left aligned.

1 = The period is center aligned.

• **CPOL: Channel Polarity**

0 = The OCx output waveform (output from the comparator) starts at a low level.

1 = The OCx output waveform (output from the comparator) starts at a high level.

- **CES: Counter Event Selection**

The bit CES defines when the channel counter event occurs when the period is center aligned (flag CHIDx in the [“PWM Interrupt Status Register 1”](#) on page 941).

CALG = 0 (Left Alignment):

0/1 = The channel counter event occurs at the end of the PWM period.

CALG = 1 (Center Alignment):

0 = The channel counter event occurs at the end of the PWM period.

1 = The channel counter event occurs at the end of the PWM period and at half the PWM period.

- **DTE: Dead-Time Generator Enable**

0 = The dead-time generator is disabled.

1 = The dead-time generator is enabled.

- **DTHI: Dead-Time PWMHx Output Inverted**

0 = The dead-time PWMHx output is not inverted.

1 = The dead-time PWMHx output is inverted.

- **DTLI: Dead-Time PWMLx Output Inverted**

0 = The dead-time PWMLx output is not inverted.

1 = The dead-time PWMLx output is inverted.

37.7.37 PWM Channel Duty Cycle Register

Name: PWM_CDTYx [x=0..3]

Address: 0x40020204 [0], 0x40020224 [1], 0x40020244 [2], 0x40020264 [3]

Access: Read-write

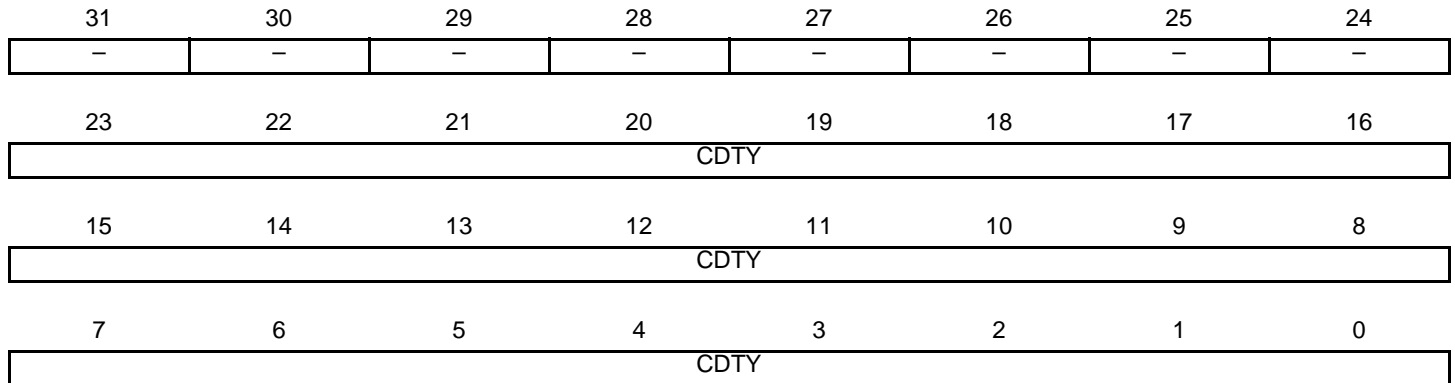

Only the first 16 bits (channel counter size) are significant.

- **CDTY: Channel Duty-Cycle**

Defines the waveform duty-cycle. This value must be defined between 0 and CPRD (PWM_CPRx).

37.7.38 PWM Channel Duty Cycle Update Register

Name: PWM_CDTYUPD_x [x=0..3]

Address: 0x40020208 [0], 0x40020228 [1], 0x40020248 [2], 0x40020268 [3]

Access: Write-only.

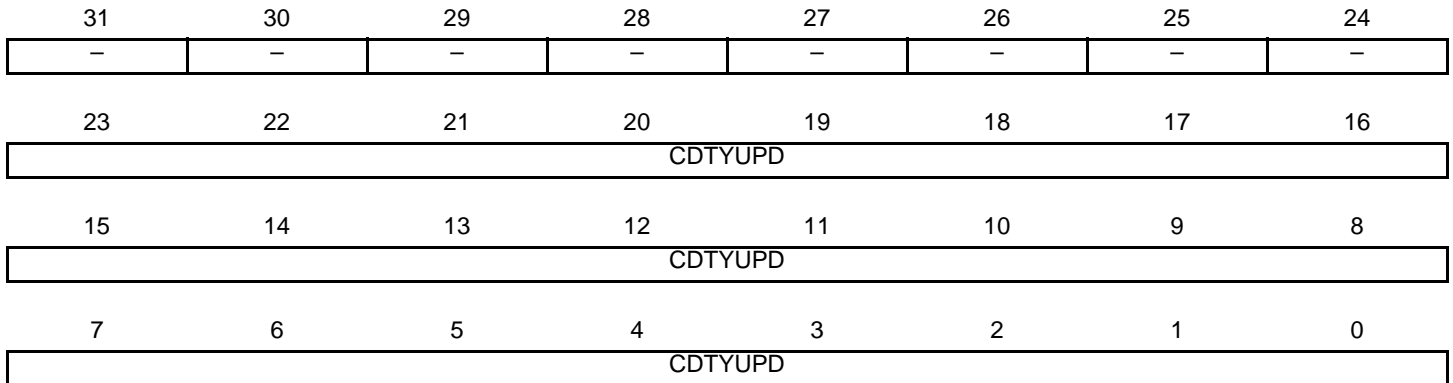

This register acts as a double buffer for the CDTY value. This prevents an unexpected waveform when modifying the waveform duty-cycle.

Only the first 16 bits (channel counter size) are significant.

- **CDTYUPD: Channel Duty-Cycle Update**

Defines the waveform duty-cycle. This value must be defined between 0 and CPRD (PWM_CPR_x).

37.7.39 PWM Channel Period Register

Name: PWM_CPRDx [x=0..3]

Address: 0x4002020C [0], 0x4002022C [1], 0x4002024C [2], 0x4002026C [3]

Access: Read-write

31	30	29	28	27	26	25	24
–	–	–	–	–	–	–	–
23	22	21	20	19	18	17	16
CPRD							
15	14	13	12	11	10	9	8
CPRD							
7	6	5	4	3	2	1	0
CPRD							

This register can only be written if the bits WPSWS3 and WPHWS3 are cleared in “PWM Write Protect Status Register” on page 965.

Only the first 16 bits (channel counter size) are significant.

- **CPRD: Channel Period**

If the waveform is left-aligned, then the output waveform period depends on the channel counter source clock and can be calculated:

- By using the PWM master clock (MCK) divided by an X given prescaler value (with X being 1, 2, 4, 8, 16, 32, 64, 128, 256, 512, or 1024). The resulting period formula will be:

$$\frac{(X \times CPRD)}{MCK}$$

- By using the PWM master clock (MCK) divided by one of both DIVA or DIVB divider, the formula becomes, respectively:

$$\frac{(CPRD \times DIVA)}{MCK} \text{ or } \frac{(CPRD \times DIVB)}{MCK}$$

If the waveform is center-aligned, then the output waveform period depends on the channel counter source clock and can be calculated:

- By using the PWM master clock (MCK) divided by an X given prescaler value (with X being 1, 2, 4, 8, 16, 32, 64, 128, 256, 512, or 1024). The resulting period formula will be:

$$\frac{(2 \times X \times CPRD)}{MCK}$$

- By using the PWM master clock (MCK) divided by one of both DIVA or DIVB divider, the formula becomes, respectively:

$$\frac{(2 \times CPRD \times DIVA)}{MCK} \text{ or } \frac{(2 \times CPRD \times DIVB)}{MCK}$$

37.7.40 PWM Channel Period Update Register

Name: PWM_CPRDUPx [x=0..3]

Address: 0x40020210 [0], 0x40020230 [1], 0x40020250 [2], 0x40020270 [3]

Access: Write-only

31	30	29	28	27	26	25	24
–	–	–	–	–	–	–	–
23	22	21	20	19	18	17	16
CPRDUPD							
15	14	13	12	11	10	9	8
CPRDUPD							
7	6	5	4	3	2	1	0
CPRDUPD							

This register can only be written if the bits WPSWS3 and WPHWS3 are cleared in “PWM Write Protect Status Register” on page 965.

This register acts as a double buffer for the CPRD value. This prevents an unexpected waveform when modifying the waveform period.

Only the first 16 bits (channel counter size) are significant.

• CPRDUPD: Channel Period Update

If the waveform is left-aligned, then the output waveform period depends on the channel counter source clock and can be calculated:

- By using the PWM master clock (MCK) divided by an X given prescaler value (with X being 1, 2, 4, 8, 16, 32, 64, 128, 256, 512, or 1024). The resulting period formula will be:

$$\frac{(X \times \text{CPRDUPD})}{\text{MCK}}$$

- By using the PWM master clock (MCK) divided by one of both DIVA or DIVB divider, the formula becomes, respectively:

$$\frac{(\text{CPRDUPD} \times \text{DIVA})}{\text{MCK}} \text{ or } \frac{(\text{CPRDUPD} \times \text{DIVB})}{\text{MCK}}$$

If the waveform is center-aligned, then the output waveform period depends on the channel counter source clock and can be calculated:

- By using the PWM master clock (MCK) divided by an X given prescaler value (with X being 1, 2, 4, 8, 16, 32, 64, 128, 256, 512, or 1024). The resulting period formula will be:

$$\frac{(2 \times X \times \text{CPRDUPD})}{\text{MCK}}$$

- By using the PWM master clock (MCK) divided by one of both DIVA or DIVB divider, the formula becomes, respectively:

$$\frac{(2 \times \text{CPRDUPD} \times \text{DIVA})}{\text{MCK}} \text{ or } \frac{(2 \times \text{CPRDUPD} \times \text{DIVB})}{\text{MCK}}$$



37.7.41 PWM Channel Counter Register

Name: PWM_CCNTx [x=0..3]

Address: 0x40020214 [0], 0x40020234 [1], 0x40020254 [2], 0x40020274 [3]

Access: Read-only

31	30	29	28	27	26	25	24
–	–	–	–	–	–	–	–
23	22	21	20	19	18	17	16
CNT							
15	14	13	12	11	10	9	8
CNT							
7	6	5	4	3	2	1	0
CNT							

Only the first 16 bits (channel counter size) are significant.

- **CNT: Channel Counter Register**

Channel counter value. This register is reset when:

- the channel is enabled (writing CHIDx in the PWM_ENA register).
- the channel counter reaches CPRD value defined in the PWM_CPRDx register if the waveform is left aligned.

37.7.42 PWM Channel Dead Time Register

Name: PWM_DT_x [x=0..3]

Address: 0x40020218 [0], 0x40020238 [1], 0x40020258 [2], 0x40020278 [3]

Access: Read-write

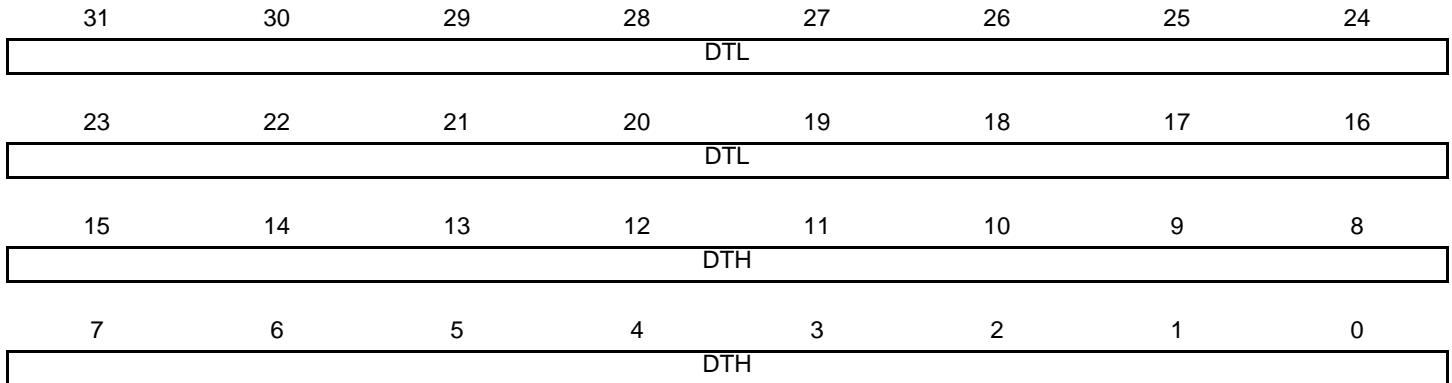

This register can only be written if the bits WPSWS4 and WPHWS4 are cleared in “[PWM Write Protect Status Register](#)” on [page 965](#).

Only the first 12 bits (dead-time counter size) of fields DTH and DTL are significant.

- **DTH: Dead-Time Value for PWMHx Output**

Defines the dead-time value for PWMHx output. This value must be defined between 0 and CPRD-CDTY (PWM_CPR_x and PWM_CDTY_x).

- **DTL: Dead-Time Value for PWMLx Output**

Defines the dead-time value for PWMLx output. This value must be defined between 0 and CDTY (PWM_CDTY_x).

37.7.43 PWM Channel Dead Time Update Register

Name: PWM_DTUPDx [x=0..3]

Address: 0x4002021C [0], 0x4002023C [1], 0x4002025C [2], 0x4002027C [3]

Access: Write-only

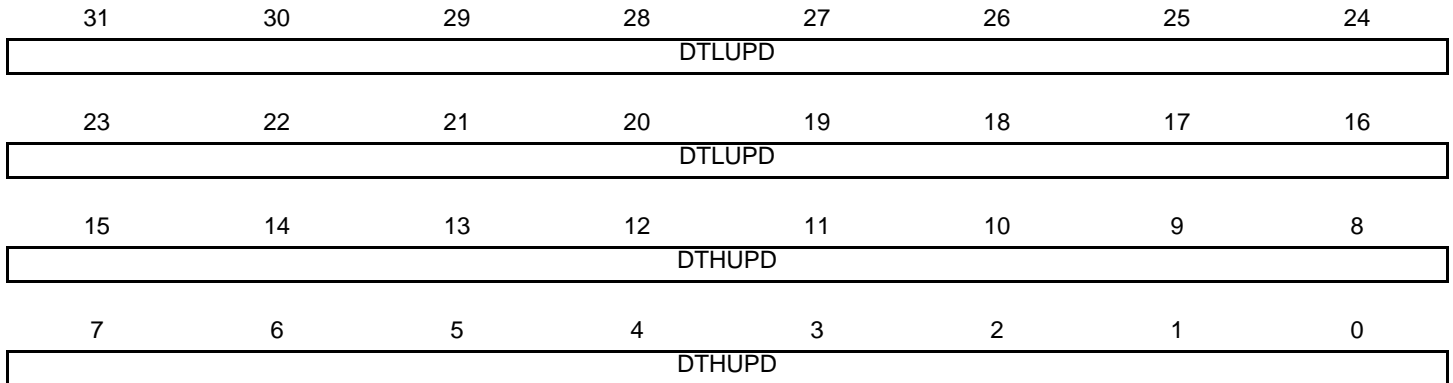

This register can only be written if the bits WPSWS4 and WPHWS4 are cleared in “[PWM Write Protect Status Register](#)” on [page 965](#).

This register acts as a double buffer for the DTH and DTL values. This prevents an unexpected waveform when modifying the dead-time values.

Only the first 12 bits (dead-time counter size) of fields DTHUPD and DTLUPD are significant.

- **DTHUPD: Dead-Time Value Update for PWMHx Output**

Defines the dead-time value for PWMHx output. This value must be defined between 0 and CPRD-CDTY (PWM_CPRx and PWM_CDTYx). This value is applied only at the beginning of the next channel x PWM period.

- **DTLUPD: Dead-Time Value Update for PWMLx Output**

Defines the dead-time value for PWMLx output. This value must be defined between 0 and CDTY (PWM_CDTYx). This value is applied only at the beginning of the next channel x PWM period.

38. USB Device Port (UDP)

38.1 Description

The USB Device Port (UDP) is compliant with the Universal Serial Bus (USB) V2.0 full-speed device specification.

Each endpoint can be configured in one of several USB transfer types. It can be associated with one or two banks of a dual-port RAM used to store the current data payload. If two banks are used, one DPR bank is read or written by the processor, while the other is read or written by the USB device peripheral. This feature is mandatory for isochronous endpoints. Thus the device maintains the maximum bandwidth (1M bytes/s) by working with endpoints with two banks of DPR.

Table 38-1. USB Endpoint Description

Endpoint Number	Mnemonic	Dual-Bank ⁽¹⁾	Max. Endpoint Size	Endpoint Type
0	EP0	No	64	Control/Bulk/Interrupt
1	EP1	Yes	64	Bulk/Iso/Interrupt
2	EP2	Yes	64	Bulk/Iso/Interrupt
3	EP3	No	64	Control/Bulk/Interrupt
4	EP4	Yes	512	Bulk/Iso/Interrupt
5	EP5	Yes	512	Bulk/Iso/Interrupt
6	EP6	Yes	64	Bulk/Iso/Interrupt
7	EP7	Yes	64	Bulk/Iso/Interrupt

Note: 1. The Dual-Bank function provides two banks for an endpoint. This feature is used for ping-pong mode.

Suspend and resume are automatically detected by the USB device, which notifies the processor by raising an interrupt. Depending on the product, an external signal can be used to send a wake up to the USB host controller.

38.2 Embedded Characteristics

- USB V2.0 full-speed compliant, 12 Mbits per second
- Embedded USB V2.0 full-speed transceiver
- Embedded 2688-byte dual-port RAM for endpoints
- Eight endpoints
 - Endpoint 0: 64bytes
 - Endpoint 1 and 2: 64 bytes ping-pong
 - Endpoint 3: 64 bytes
 - Endpoint 4 and 5: 512 bytes ping-pong
 - Endpoint 6 and 7: 64 bytes ping-pong
 - Ping-pong Mode (two memory banks) for Isochronous and bulk endpoints
- Suspend/resume logic
- Integrated Pull-up on DDP
- Pull-down resistor on DDM and DDP when disabled

38.3 Block Diagram

Figure 38-1. Block Diagram

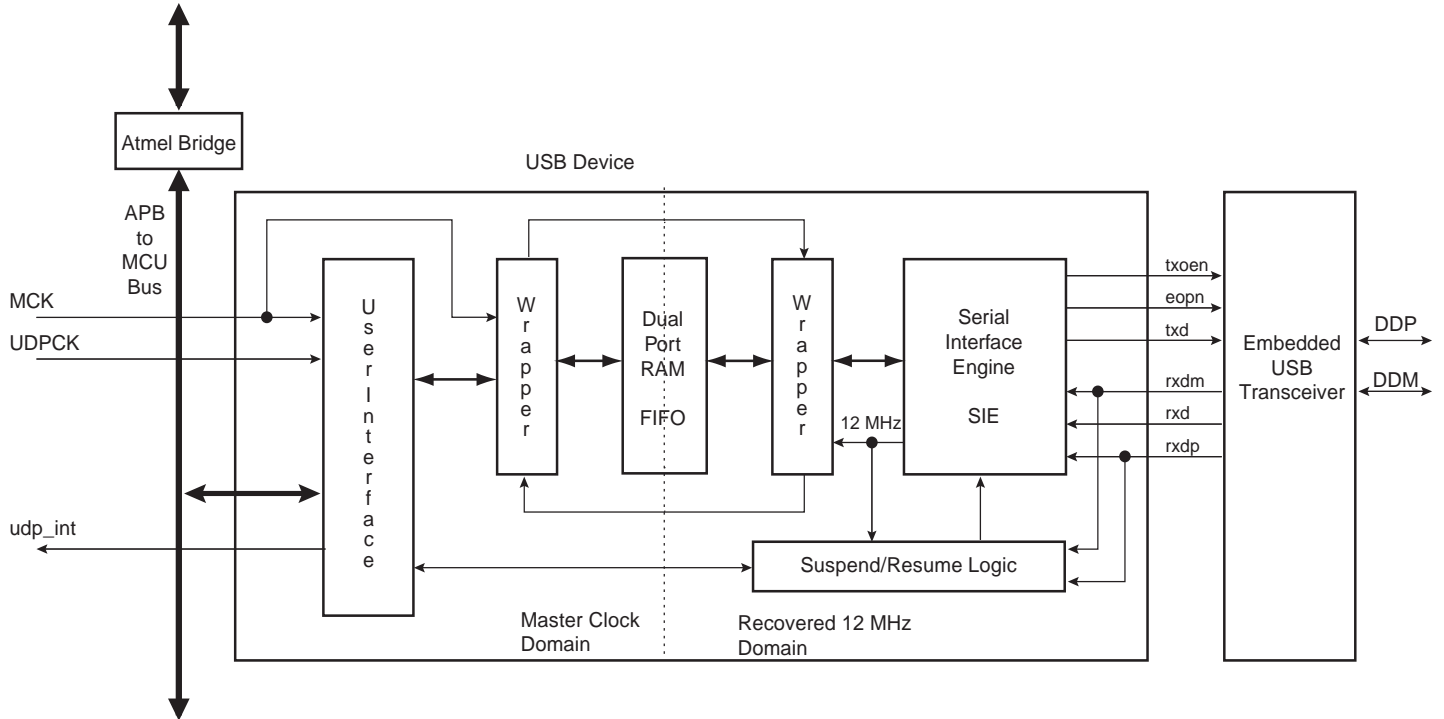

Access to the UDP is via the APB bus interface. Read and write to the data FIFO are done by reading and writing 8-bit values to APB registers.

The UDP peripheral requires two clocks: one peripheral clock used by the Master Clock domain (MCK) and a 48 MHz clock (UDPCCK) used by the 12 MHz domain.

A USB 2.0 full-speed pad is embedded and controlled by the Serial Interface Engine (SIE).

The signal external_resume is optional. It allows the UDP peripheral to wake up once in system mode. The host is then notified that the device asks for a resume. This optional feature must also be negotiated with the host during the enumeration.

38.3.1 Signal Description

Table 38-2. Signal Names

Signal Name	Description	Type
UDPCCK	48 MHz clock	input
MCK	Master clock	input
udp_int	Interrupt line connected to the Interrupt Controller	input
DDP	USB D+ line	I/O
DDM	USB D- line	I/O

38.4 Product Dependencies

For further details on the USB Device hardware implementation, see the specific Product Properties document.

The USB physical transceiver is integrated into the product. The bidirectional differential signals DDP and DDM are available from the product boundary.

One I/O line may be used by the application to check that VBUS is still available from the host. Self-powered devices may use this entry to be notified that the host has been powered off. In this case, the pullup on DP must be disabled in order to prevent feeding current to the host. The application should disconnect the transceiver, then remove the pullup.

38.4.1 I/O Lines

The USB pins are shared with PIO lines. By default, the USB function is activated, and pins DDP and DDM are used for USB. To configure DDP or DDM as PIOs, the user needs to configure the system I/O configuration register (CCFG_SYSIO) in the MATRIX.

38.4.2 Power Management

The USB device peripheral requires a 48 MHz clock. This clock must be generated by a PLL with an accuracy of $\pm 0.25\%$.

Thus, the USB device receives two clocks from the Power Management Controller (PMC): the master clock, MCK, used to drive the peripheral user interface, and the UDPCK, used to interface with the bus USB signals (recovered 12 MHz domain).

WARNING: The UDP peripheral clock in the Power Management Controller (PMC) must be enabled before any read/write operations to the UDP registers including the UDP_TXVC register.

38.4.3 Interrupt

The USB device interface has an interrupt line connected to the Interrupt Controller.

Handling the USB device interrupt requires programming the Interrupt Controller before configuring the UDP.

Table 38-3. Peripheral IDs

Instance	ID
UDP	34

38.5 Typical Connection

Figure 38-2. Board Schematic to Interface Device Peripheral

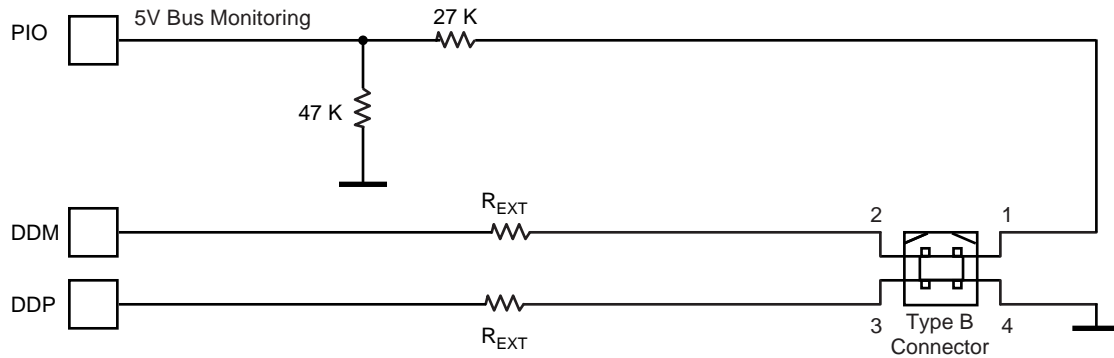

38.5.1 USB Device Transceiver

The USB device transceiver is embedded in the product. A few discrete components are required as follows:

- The application detects all device states as defined in chapter 9 of the USB specification;
 - VBUS monitoring
- To reduce power consumption the host is disconnected
- For line termination.

38.5.2 VBUS Monitoring

VBUS monitoring is required to detect host connection. VBUS monitoring is done using a standard PIO with internal pullup disabled. When the host is switched off, it should be considered as a disconnect, the pullup must be disabled in order to prevent powering the host through the pull-up resistor.

When the host is disconnected and the transceiver is enabled, then DDP and DDM are floating. This may lead to over consumption. A solution is to enable the integrated pulldown by disabling the transceiver ($TXVDIS = 1$) and then remove the pullup ($PUON = 0$).

A termination serial resistor must be connected to DDP and DDM. The resistor value is defined in the electrical specification of the product (R_{EXT}).

38.6 Functional Description

38.6.1 USB V2.0 Full-speed Introduction

The USB V2.0 full-speed provides communication services between host and attached USB devices. Each device is offered with a collection of communication flows (pipes) associated with each endpoint. Software on the host communicates with a USB device through a set of communication flows.

Figure 38-3. Example of USB V2.0 Full-speed Communication Control

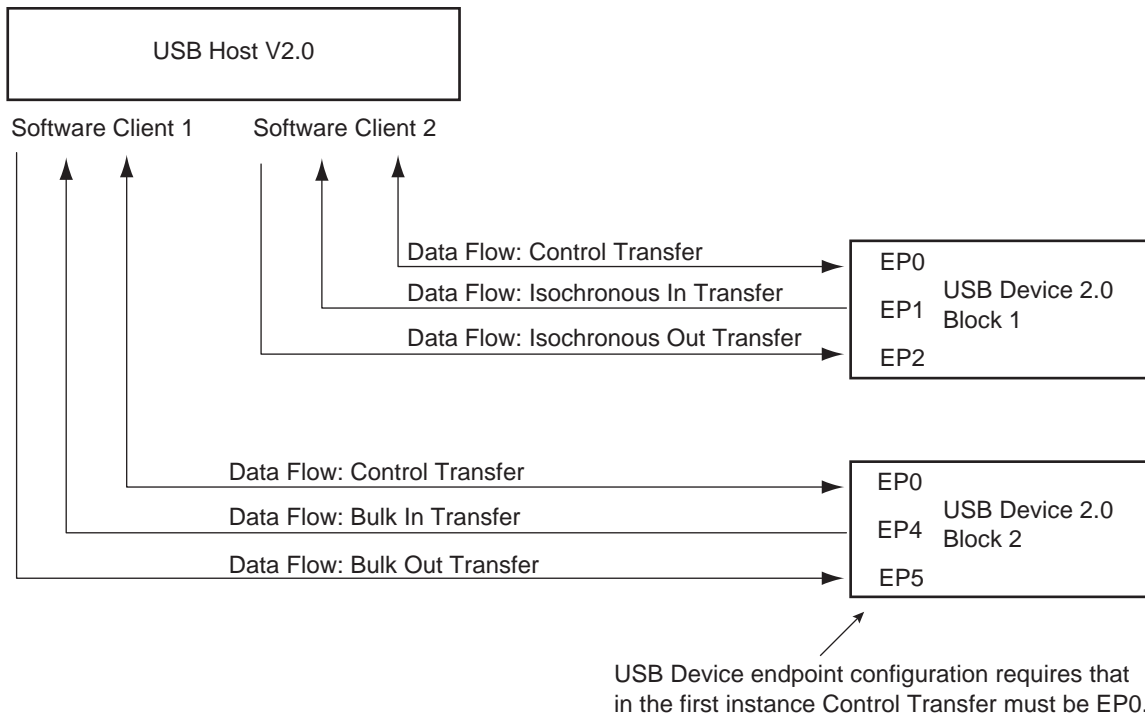

Figure 38-4.

The Control Transfer endpoint EP0 is always used when a USB device is first configured (USB v. 2.0 specifications).

38.6.1.1 USB V2.0 Full-speed Transfer Types

A communication flow is carried over one of four transfer types defined by the USB device.

Table 38-4. USB Communication Flow

Transfer	Direction	Bandwidth	Supported Endpoint Size	Error Detection	Retrying
Control	Bidirectional	Not guaranteed	8, 16, 32, 64	Yes	Automatic
Isochronous	Unidirectional	Guaranteed	512	Yes	No
Interrupt	Unidirectional	Not guaranteed	≤64	Yes	Yes
Bulk	Unidirectional	Not guaranteed	8, 16, 32, 64	Yes	Yes

38.6.1.2 USB Bus Transactions

Each transfer results in one or more transactions over the USB bus. There are three kinds of transactions flowing across the bus in packets:

1. Setup Transaction
2. Data IN Transaction
3. Data OUT Transaction

38.6.1.3 USB Transfer Event Definitions

As indicated below, transfers are sequential events carried out on the USB bus.

Table 38-5. USB Transfer Events

Control Transfers ^{(1) (3)}	<ul style="list-style-type: none"> • Setup transaction > Data IN transactions > Status OUT transaction • Setup transaction > Data OUT transactions > Status IN transaction • Setup transaction > Status IN transaction
Interrupt IN Transfer (device toward host)	<ul style="list-style-type: none"> • Data IN transaction > Data IN transaction
Interrupt OUT Transfer (host toward device)	<ul style="list-style-type: none"> • Data OUT transaction > Data OUT transaction
Isochronous IN Transfer ⁽²⁾ (device toward host)	<ul style="list-style-type: none"> • Data IN transaction > Data IN transaction
Isochronous OUT Transfer ⁽²⁾ (host toward device)	<ul style="list-style-type: none"> • Data OUT transaction > Data OUT transaction
Bulk IN Transfer (device toward host)	<ul style="list-style-type: none"> • Data IN transaction > Data IN transaction
Bulk OUT Transfer (host toward device)	<ul style="list-style-type: none"> • Data OUT transaction > Data OUT transaction

- Notes:
1. Control transfer must use endpoints with no ping-pong attributes.
 2. Isochronous transfers must use endpoints with ping-pong attributes.
 3. Control transfers can be aborted using a stall handshake.

A status transaction is a special type of host-to-device transaction used only in a control transfer. The control transfer must be performed using endpoints with no ping-pong attributes. According to the control sequence (read or write), the USB device sends or receives a status transaction.

Figure 38-5. Control Read and Write Sequences

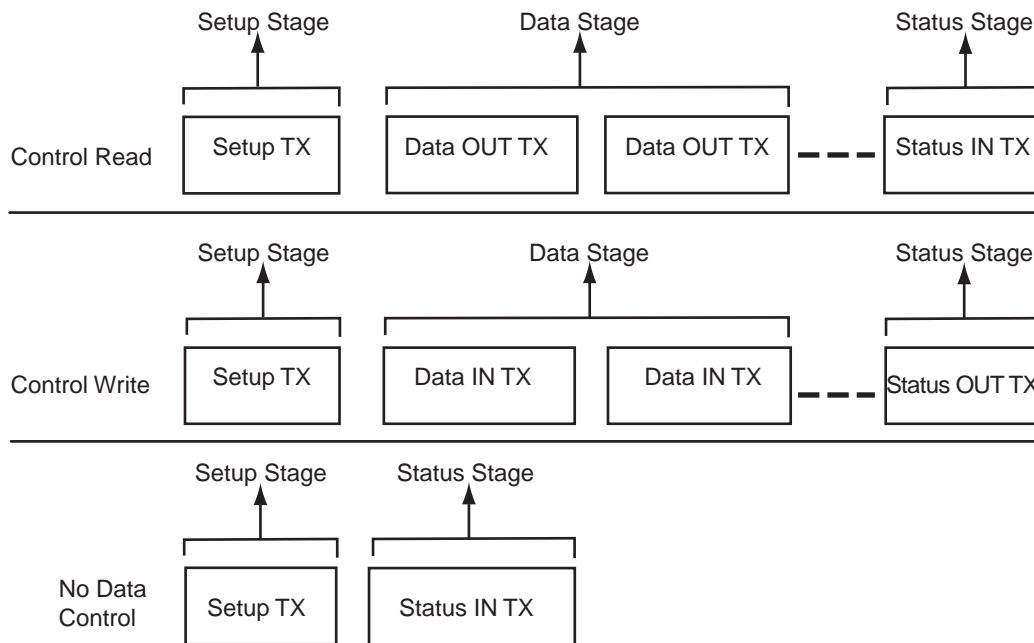

- Notes:
1. During the Status IN stage, the host waits for a zero length packet (Data IN transaction with no data) from the device using DATA1 PID. Refer to Chapter 8 of the *Universal Serial Bus Specification, Rev. 2.0*, for more information on the protocol layer.
 2. During the Status OUT stage, the host emits a zero length packet to the device (Data OUT transaction with no data).

38.6.2 Handling Transactions with USB V2.0 Device Peripheral

38.6.2.1 Setup Transaction

Setup is a special type of host-to-device transaction used during control transfers. Control transfers must be performed using endpoints with no ping-pong attributes. A setup transaction needs to be handled as soon as possible by the firmware. It is used to transmit requests from the host to the device. These requests are then handled by the USB device and may require more arguments. The arguments are sent to the device by a Data OUT transaction which follows the setup transaction. These requests may also return data. The data is carried out to the host by the next Data IN transaction which follows the setup transaction. A status transaction ends the control transfer.

When a setup transfer is received by the USB endpoint:

- The USB device automatically acknowledges the setup packet
- RXSETUP is set in the UDP_CSRx register
- An endpoint interrupt is generated while the RXSETUP is not cleared. This interrupt is carried out to the microcontroller if interrupts are enabled for this endpoint.

Thus, firmware must detect the RXSETUP polling the UDP_CSRx or catching an interrupt, read the setup packet in the FIFO, then clear the RXSETUP. RXSETUP cannot be cleared before the setup packet has been read in the FIFO. Otherwise, the USB device would accept the next Data OUT transfer and overwrite the setup packet in the FIFO.

Figure 38-6. Setup Transaction Followed by a Data OUT Transaction

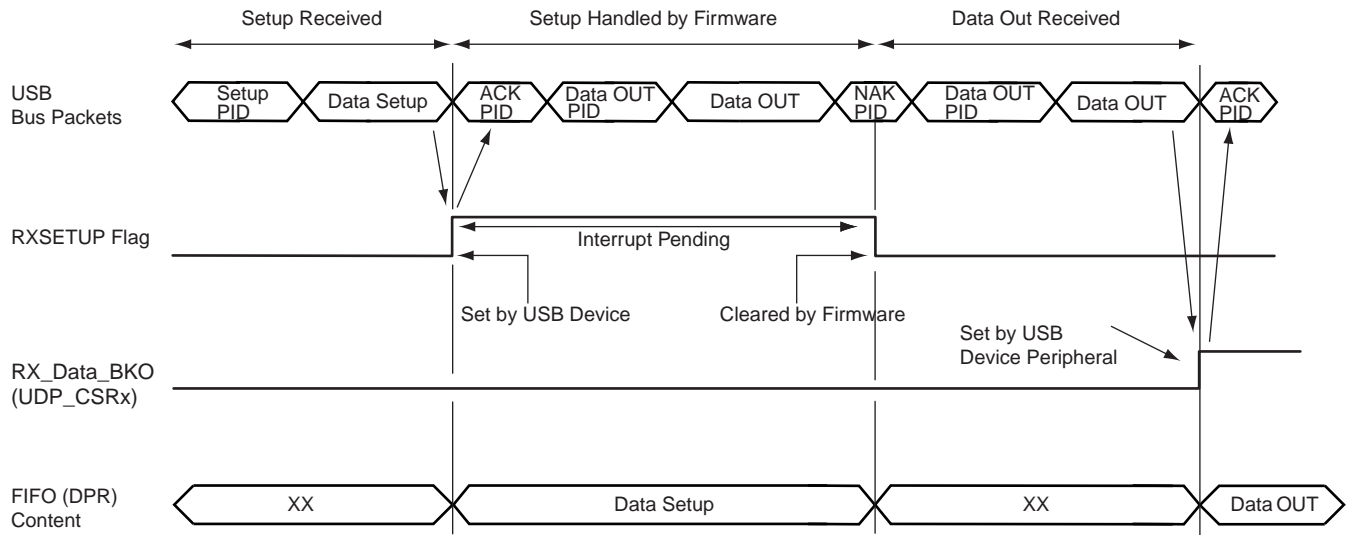

38.6.2.2 Data IN Transaction

Data IN transactions are used in control, isochronous, bulk and interrupt transfers and conduct the transfer of data from the device to the host. Data IN transactions in isochronous transfer must be done using endpoints with ping-pong attributes.

Using Endpoints Without Ping-pong Attributes

To perform a Data IN transaction using a non ping-pong endpoint:

1. The application checks if it is possible to write in the FIFO by polling TXPKTRDY in the endpoint's UDP_CSRx register (TXPKTRDY must be cleared).
2. The application writes the first packet of data to be sent in the endpoint's FIFO, writing zero or more byte values in the endpoint's UDP_FDRx register,
3. The application notifies the USB peripheral it has finished by setting the TXPKTRDY in the endpoint's UDP_CSRx register.
4. The application is notified that the endpoint's FIFO has been released by the USB device when TXCOMP in the endpoint's UDP_CSRx register has been set. Then an interrupt for the corresponding endpoint is pending while TXCOMP is set.
5. The microcontroller writes the second packet of data to be sent in the endpoint's FIFO, writing zero or more byte values in the endpoint's UDP_FDRx register,
6. The microcontroller notifies the USB peripheral it has finished by setting the TXPKTRDY in the endpoint's UDP_CSRx register.
7. The application clears the TXCOMP in the endpoint's UDP_CSRx.

After the last packet has been sent, the application must clear TXCOMP once this has been set.

TXCOMP is set by the USB device when it has received an ACK PID signal for the Data IN packet. An interrupt is pending while TXCOMP is set.

Warning: TX_COMP must be cleared after TX_PKTRDY has been set.

Note: Refer to Chapter 8 of the *Universal Serial Bus Specification, Rev 2.0*, for more information on the Data IN protocol layer.

Figure 38-7. Data IN Transfer for Non Ping-pong Endpoint

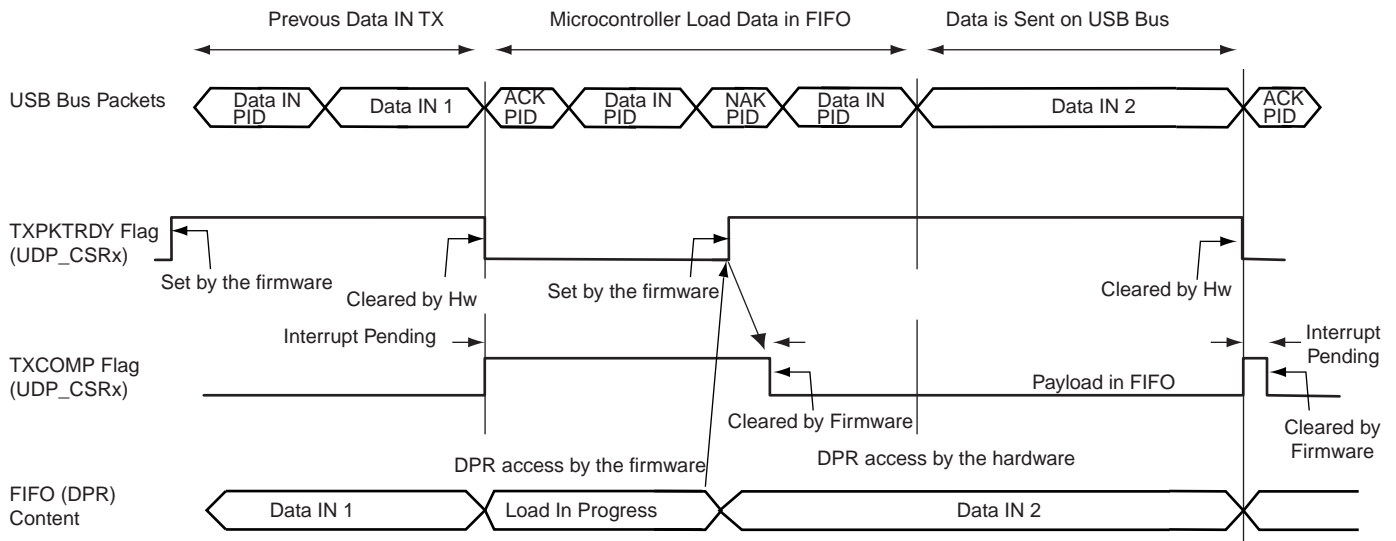

Using Endpoints With Ping-pong Attribute

The use of an endpoint with ping-pong attributes is necessary during isochronous transfer. This also allows handling the maximum bandwidth defined in the USB specification during bulk transfer. To be able to guarantee a constant or the maximum bandwidth, the microcontroller must prepare the next data payload to be sent while the current one is being sent by the USB device. Thus two banks of memory are used. While one is available for the microcontroller, the other one is locked by the USB device.

Figure 38-8. Bank Swapping Data IN Transfer for Ping-pong Endpoints

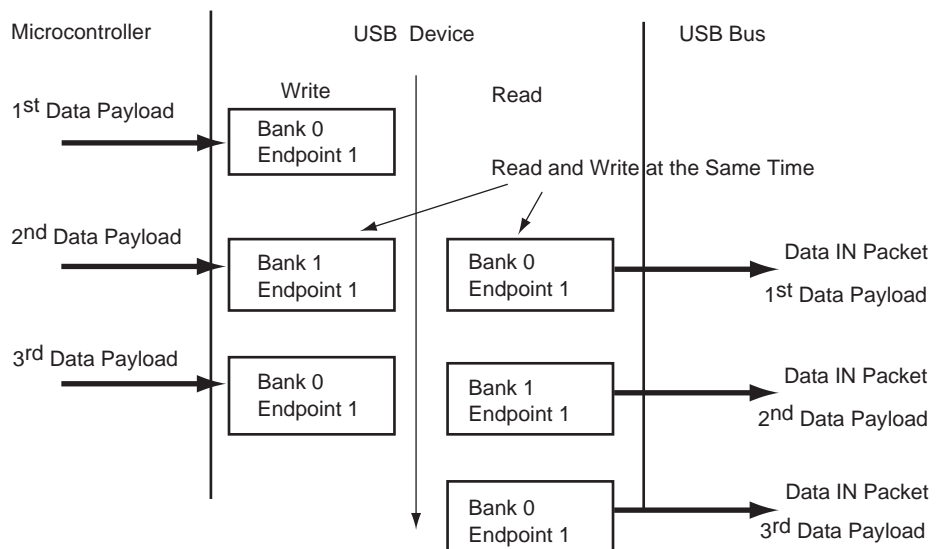

When using a ping-pong endpoint, the following procedures are required to perform Data IN transactions:

1. The microcontroller checks if it is possible to write in the FIFO by polling TXPKTRDY to be cleared in the endpoint's UDP_CSRx register.
2. The microcontroller writes the first data payload to be sent in the FIFO (Bank 0), writing zero or more byte values in the endpoint's UDP_FDRx register.
3. The microcontroller notifies the USB peripheral it has finished writing in Bank 0 of the FIFO by setting the TXPKTRDY in the endpoint's UDP_CSRx register.
4. Without waiting for TXPKTRDY to be cleared, the microcontroller writes the second data payload to be sent in the FIFO (Bank 1), writing zero or more byte values in the endpoint's UDP_FDRx register.
5. The microcontroller is notified that the first Bank has been released by the USB device when TXCOMP in the endpoint's UDP_CSRx register is set. An interrupt is pending while TXCOMP is being set.
6. Once the microcontroller has received TXCOMP for the first Bank, it notifies the USB device that it has prepared the second Bank to be sent, raising TXPKTRDY in the endpoint's UDP_CSRx register.
7. At this step, Bank 0 is available and the microcontroller can prepare a third data payload to be sent.

Figure 38-9. Data IN Transfer for Ping-pong Endpoint

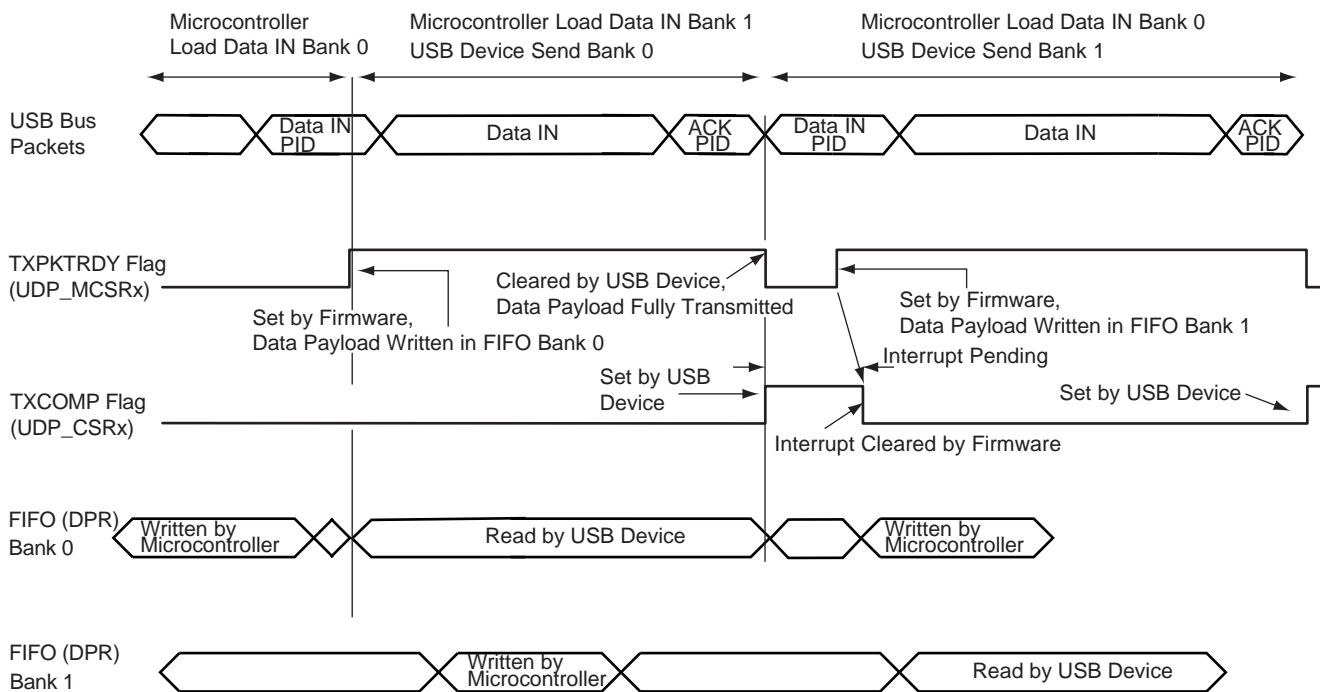

Warning: There is software critical path due to the fact that once the second bank is filled, the driver has to wait for TX_COMP to set TX_PKTRDY. If the delay between receiving TX_COMP is set and TX_PKTRDY is set too long, some Data IN packets may be NACKed, reducing the bandwidth.

Warning: TX_COMP must be cleared after TX_PKTRDY has been set.

38.6.2.3 Data OUT Transaction

Data OUT transactions are used in control, isochronous, bulk and interrupt transfers and conduct the transfer of data from the host to the device. Data OUT transactions in isochronous transfers must be done using endpoints with ping-pong attributes.

Data OUT Transaction Without Ping-pong Attributes

To perform a Data OUT transaction, using a non ping-pong endpoint:

1. The host generates a Data OUT packet.
2. This packet is received by the USB device endpoint. While the FIFO associated to this endpoint is being used by the microcontroller, a NAK PID is returned to the host. Once the FIFO is available, data are written to the FIFO by the USB device and an ACK is automatically carried out to the host.
3. The microcontroller is notified that the USB device has received a data payload polling RX_DATA_BK0 in the endpoint's UDP_CSRx register. An interrupt is pending for this endpoint while RX_DATA_BK0 is set.
4. The number of bytes available in the FIFO is made available by reading RXBYTECNT in the endpoint's UDP_CSRx register.
5. The microcontroller carries out data received from the endpoint's memory to its memory. Data received is available by reading the endpoint's UDP_FDRx register.
6. The microcontroller notifies the USB device that it has finished the transfer by clearing RX_DATA_BK0 in the endpoint's UDP_CSRx register.
7. A new Data OUT packet can be accepted by the USB device.

Figure 38-10. Data OUT Transfer for Non Ping-pong Endpoints

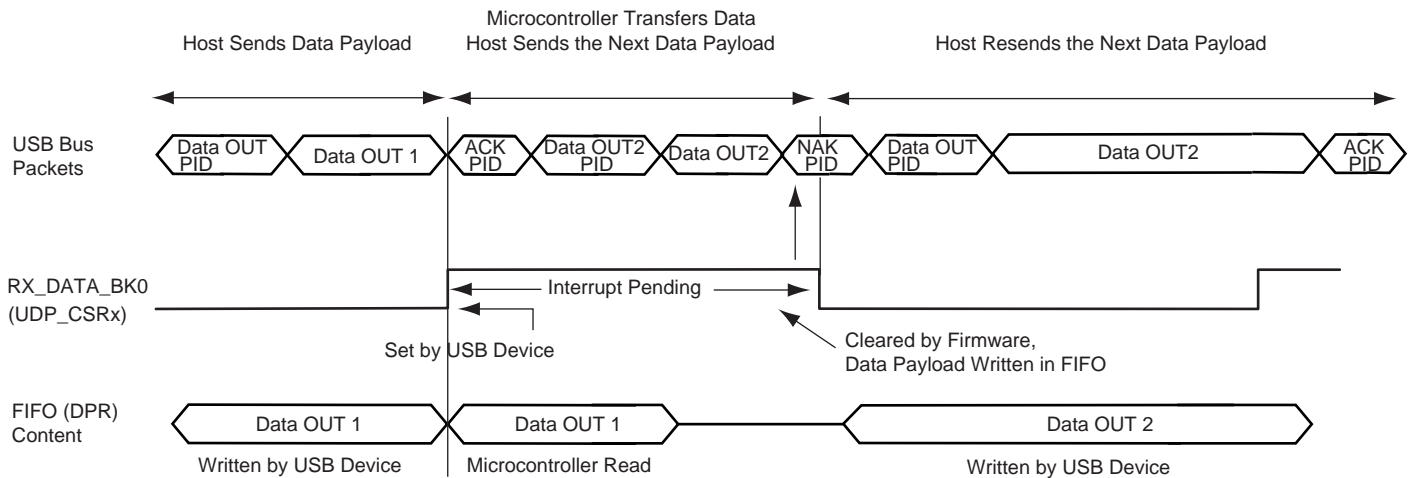

An interrupt is pending while the flag RX_DATA_BK0 is set. Memory transfer between the USB device, the FIFO and microcontroller memory can not be done after RX_DATA_BK0 has been cleared. Otherwise, the USB device would accept the next Data OUT transfer and overwrite the current Data OUT packet in the FIFO.

Using Endpoints With Ping-pong Attributes

During isochronous transfer, using an endpoint with ping-pong attributes is obligatory. To be able to guarantee a constant bandwidth, the microcontroller must read the previous data payload sent by the host, while the current data payload is received by the USB device. Thus two

banks of memory are used. While one is available for the microcontroller, the other one is locked by the USB device.

Figure 38-11. Bank Swapping in Data OUT Transfers for Ping-pong Endpoints

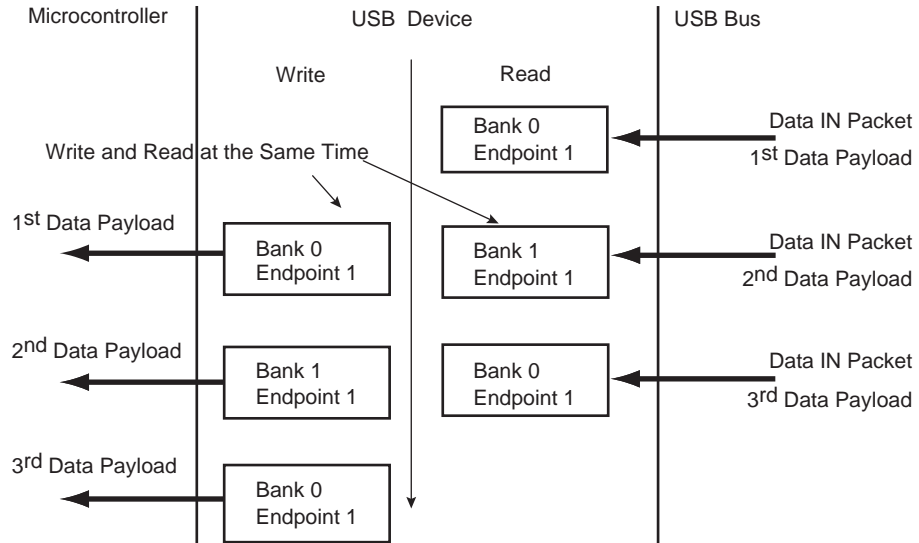

When using a ping-pong endpoint, the following procedures are required to perform Data OUT transactions:

1. The host generates a Data OUT packet.
2. This packet is received by the USB device endpoint. It is written in the endpoint's FIFO Bank 0.
3. The USB device sends an ACK PID packet to the host. The host can immediately send a second Data OUT packet. It is accepted by the device and copied to FIFO Bank 1.
4. The microcontroller is notified that the USB device has received a data payload, polling `RX_DATA_BK0` in the endpoint's `UDP_CSRx` register. An interrupt is pending for this endpoint while `RX_DATA_BK0` is set.
5. The number of bytes available in the FIFO is made available by reading `RXBYTECNT` in the endpoint's `UDP_CSRx` register.
6. The microcontroller transfers out data received from the endpoint's memory to the microcontroller's memory. Data received is made available by reading the endpoint's `UDP_FDRx` register.
7. The microcontroller notifies the USB peripheral device that it has finished the transfer by clearing `RX_DATA_BK0` in the endpoint's `UDP_CSRx` register.
8. A third Data OUT packet can be accepted by the USB peripheral device and copied in the FIFO Bank 0.
9. If a second Data OUT packet has been received, the microcontroller is notified by the flag `RX_DATA_BK1` set in the endpoint's `UDP_CSRx` register. An interrupt is pending for this endpoint while `RX_DATA_BK1` is set.
10. The microcontroller transfers out data received from the endpoint's memory to the microcontroller's memory. Data received is available by reading the endpoint's `UDP_FDRx` register.

11. The microcontroller notifies the USB device it has finished the transfer by clearing RX_DATA_BK1 in the endpoint's UDP_CSRx register.
12. A fourth Data OUT packet can be accepted by the USB device and copied in the FIFO Bank 0.

Figure 38-12. Data OUT Transfer for Ping-pong Endpoint

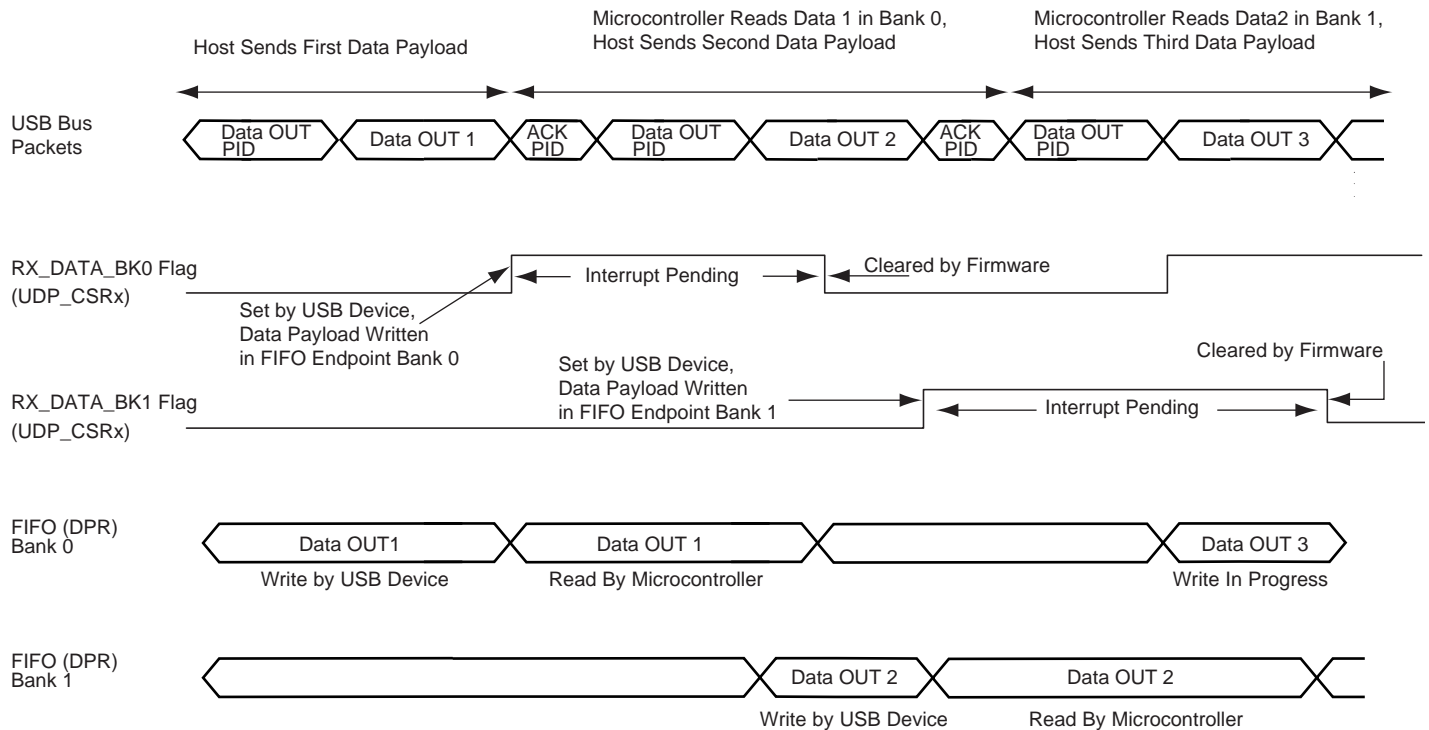

Note: An interrupt is pending while the RX_DATA_BK0 or RX_DATA_BK1 flag is set.

Warning: When RX_DATA_BK0 and RX_DATA_BK1 are both set, there is no way to determine which one to clear first. Thus the software must keep an internal counter to be sure to clear alternately RX_DATA_BK0 then RX_DATA_BK1. This situation may occur when the software application is busy elsewhere and the two banks are filled by the USB host. Once the application comes back to the USB driver, the two flags are set.

38.6.2.4 Stall Handshake

A stall handshake can be used in one of two distinct occasions. (For more information on the stall handshake, refer to Chapter 8 of the *Universal Serial Bus Specification, Rev 2.0*.)

- A functional stall is used when the halt feature associated with the endpoint is set. (Refer to Chapter 9 of the *Universal Serial Bus Specification, Rev 2.0*, for more information on the halt feature.)
- To abort the current request, a protocol stall is used, but uniquely with control transfer.

The following procedure generates a stall packet:

1. The microcontroller sets the FORCESTALL flag in the UDP_CSRx endpoint's register.
2. The host receives the stall packet.

3. The microcontroller is notified that the device has sent the stall by polling the STALLSENT to be set. An endpoint interrupt is pending while STALLSENT is set. The microcontroller must clear STALLSENT to clear the interrupt.

When a setup transaction is received after a stall handshake, STALLSENT must be cleared in order to prevent interrupts due to STALLSENT being set.

Figure 38-13. Stall Handshake (Data IN Transfer)

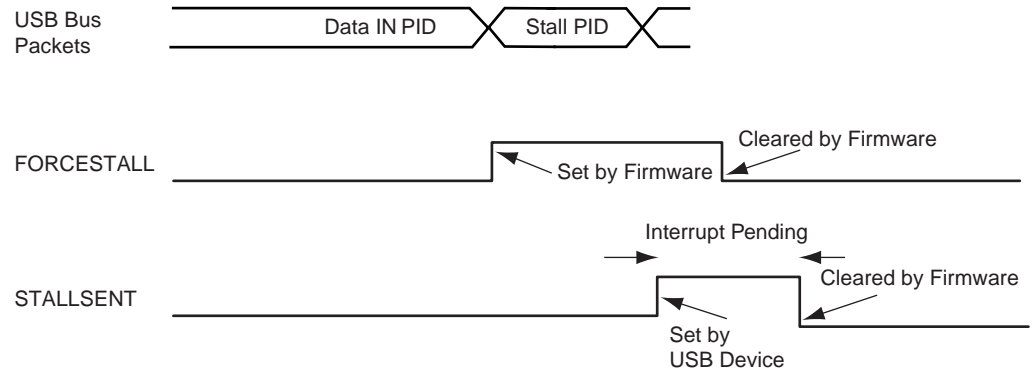
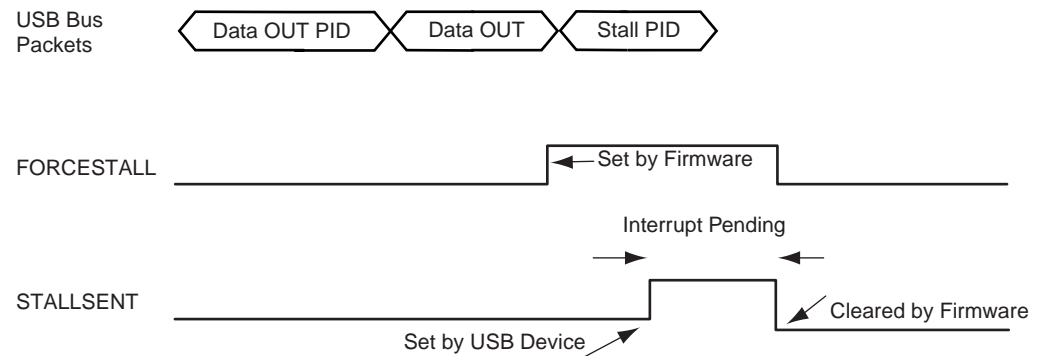

Figure 38-14. Stall Handshake (Data OUT Transfer)



38.6.2.5 Transmit Data Cancellation

Some endpoints have dual-banks whereas some endpoints have only one bank. The procedure to cancel transmission data held in these banks is described below.

To see the organization of dual-bank availability refer to [Table 38-1 "USB Endpoint Description"](#).

Endpoints **Without** Dual-Banks

There are two possibilities: In one case, TXPKTRDY field in UDP_CSR has already been set. In the other instance, TXPKTRDY is not set.

- TXPKTRDY is not set:
 - Reset the endpoint to clear the FIFO (pointers). (See, [Section 38.7.9 "UDP Reset Endpoint Register"](#).)
- TXPKTRDY has already been set:
 - Clear TXPKTRDY so that no packet is ready to be sent
 - Reset the endpoint to clear the FIFO (pointers). (See, [Section 38.7.9 "UDP Reset Endpoint Register"](#).)

Endpoints **With** Dual-Banks

There are two possibilities: In one case, TXPKTRDY field in UDP_CSR has already been set. In the other instance, TXPKTRDY is not set.

- TXPKTRDY is not set:
 - Reset the endpoint to clear the FIFO (pointers). (See, [Section 38.7.9 "UDP Reset Endpoint Register"](#).)
- TXPKTRDY has already been set:
 - Clear TXPKTRDY and read it back until actually read at 0.
 - Set TXPKTRDY and read it back until actually read at 1.
 - Clear TXPKTRDY so that no packet is ready to be sent.
 - Reset the endpoint to clear the FIFO (pointers). (See, [Section 38.7.9 "UDP Reset Endpoint Register"](#).)

38.6.3 Controlling Device States

A USB device has several possible states. Refer to Chapter 9 of the *Universal Serial Bus Specification, Rev 2.0*.

Figure 38-15. USB Device State Diagram

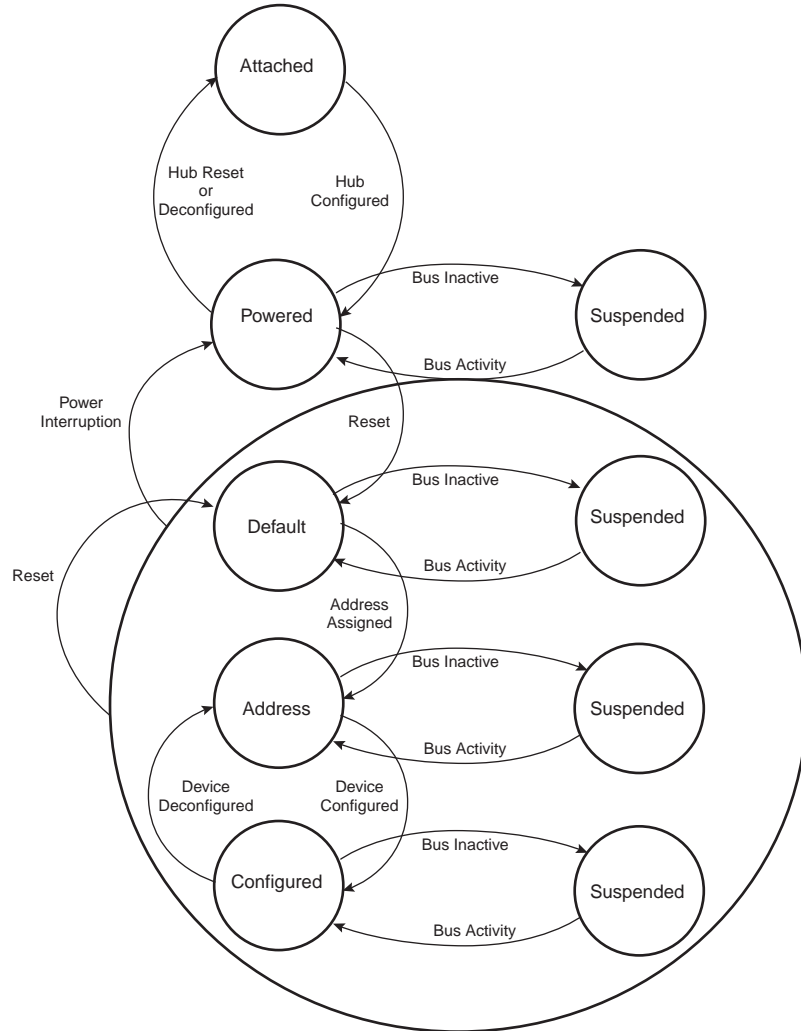

Movement from one state to another depends on the USB bus state or on standard requests sent through control transactions via the default endpoint (endpoint 0).

After a period of bus inactivity, the USB device enters Suspend Mode. Accepting Suspend/Resume requests from the USB host is mandatory. Constraints in Suspend Mode are very strict for bus-powered applications; devices may not consume more than 500 μ A on the USB bus.

While in Suspend Mode, the host may wake up a device by sending a resume signal (bus activity) or a USB device may send a wake up request to the host, e.g., waking up a PC by moving a USB mouse.

The wake up feature is not mandatory for all devices and must be negotiated with the host.

38.6.3.1 *Not Powered State*

Self powered devices can detect 5V VBUS using a PIO as described in the typical connection section. When the device is not connected to a host, device power consumption can be reduced by disabling MCK for the UDP, disabling UDPCK and disabling the transceiver. DDP and DDM lines are pulled down by 330 K Ω resistors.

38.6.3.2 *Entering Attached State*

To enable integrated pullup, the PUON bit in the UDP_TXVC register must be set.

Warning: To write to the UDP_TXVC register, MCK clock must be enabled on the UDP. This is done in the Power Management Controller.

After pullup connection, the device enters the powered state. In this state, the UDPCK and MCK must be enabled in the Power Management Controller. The transceiver can remain disabled.

38.6.3.3 *From Powered State to Default State*

After its connection to a USB host, the USB device waits for an end-of-bus reset. The unmaskable flag ENDBUSRES is set in the register UDP_ISR and an interrupt is triggered.

Once the ENDBUSRES interrupt has been triggered, the device enters Default State. In this state, the UDP software must:

- Enable the default endpoint, setting the EPEDS flag in the UDP_CSR[0] register and, optionally, enabling the interrupt for endpoint 0 by writing 1 to the UDP_IER register. The enumeration then begins by a control transfer.
- Configure the interrupt mask register which has been reset by the USB reset detection
- Enable the transceiver clearing the TXVDIS flag in the UDP_TXVC register.

In this state UDPCK and MCK must be enabled.

Warning: Each time an ENDBUSRES interrupt is triggered, the Interrupt Mask Register and UDP_CSR registers have been reset.

38.6.3.4 *From Default State to Address State*

After a set address standard device request, the USB host peripheral enters the address state.

Warning: Before the device enters in address state, it must achieve the Status IN transaction of the control transfer, i.e., the UDP device sets its new address once the TXCOMP flag in the UDP_CSR[0] register has been received and cleared.

To move to address state, the driver software sets the FADDEN flag in the UDP_GLB_STAT register, sets its new address, and sets the FEN bit in the UDP_FADDR register.

38.6.3.5 *From Address State to Configured State*

Once a valid Set Configuration standard request has been received and acknowledged, the device enables endpoints corresponding to the current configuration. This is done by setting the EPEDS and EPTYPE fields in the UDP_CSRx registers and, optionally, enabling corresponding interrupts in the UDP_IER register.

38.6.3.6 *Entering in Suspend State*

When a Suspend (no bus activity on the USB bus) is detected, the RXSUSP signal in the UDP_ISR register is set. This triggers an interrupt if the corresponding bit is set in the UDP_IMR

register. This flag is cleared by writing to the UDP_ICR register. Then the device enters Suspend Mode.

In this state bus powered devices must drain less than 500uA from the 5V VBUS. As an example, the microcontroller switches to slow clock, disables the PLL and main oscillator, and goes into Idle Mode. It may also switch off other devices on the board.

The USB device peripheral clocks can be switched off. Resume event is asynchronously detected. MCK and UDPCK can be switched off in the Power Management controller and the USB transceiver can be disabled by setting the TXVDIS field in the UDP_TXVC register.

Warning: Read, write operations to the UDP registers are allowed only if MCK is enabled for the UDP peripheral. Switching off MCK for the UDP peripheral must be one of the last operations after writing to the UDP_TXVC and acknowledging the RXSUSP.

38.6.3.7 *Receiving a Host Resume*

In suspend mode, a resume event on the USB bus line is detected asynchronously, transceiver and clocks are disabled (however the pullup shall not be removed).

Once the resume is detected on the bus, the WAKEUP signal in the UDP_ISR is set. It may generate an interrupt if the corresponding bit in the UDP_IMR register is set. This interrupt may be used to wake up the core, enable PLL and main oscillators and configure clocks.

Warning: Read, write operations to the UDP registers are allowed only if MCK is enabled for the UDP peripheral. MCK for the UDP must be enabled before clearing the WAKEUP bit in the UDP_ICR register and clearing TXVDIS in the UDP_TXVC register.

38.6.3.8 *Sending a Device Remote Wakeup*

In Suspend state it is possible to wake up the host sending an external resume.

- The device must wait at least 5 ms after being entered in suspend before sending an external resume.
- The device has 10 ms from the moment it starts to drain current and it forces a K state to resume the host.
- The device must force a K state from 1 to 15 ms to resume the host

Before sending a K state to the host, MCK, UDPCK and the transceiver must be enabled. Then to enable the remote wakeup feature, the RMWUPE bit in the UDP_GLB_STAT register must be enabled. To force the K state on the line, a transition of the ESR bit from 0 to 1 has to be done in the UDP_GLB_STAT register. This transition must be accomplished by first writing a 0 in the ESR bit and then writing a 1.

The K state is automatically generated and released according to the USB 2.0 specification.

38.7 USB Device Port (UDP) User Interface

WARNING: The UDP peripheral clock in the Power Management Controller (PMC) must be enabled before any read/write operations to the UDP registers, including the UDP_TXVC register.

Table 38-6. Register Mapping

Offset	Register	Name	Access	Reset
0x000	Frame Number Register	UDP_FRM_NUM	Read-only	0x0000_0000
0x004	Global State Register	UDP_GLB_STAT	Read-write	0x0000_0010
0x008	Function Address Register	UDP_FADDR	Read-write	0x0000_0100
0x00C	Reserved	–	–	–
0x010	Interrupt Enable Register	UDP_IER	Write-only	
0x014	Interrupt Disable Register	UDP_IDR	Write-only	
0x018	Interrupt Mask Register	UDP_IMR	Read-only	0x0000_1200
0x01C	Interrupt Status Register	UDP_ISR	Read-only	– ⁽¹⁾
0x020	Interrupt Clear Register	UDP_ICR	Write-only	
0x024	Reserved	–	–	–
0x028	Reset Endpoint Register	UDP_RST_EP	Read-write	0x0000_0000
0x02C	Reserved	–	–	–
0x030	Endpoint Control and Status Register 0	UDP_CSR0	Read-write	0x0000_0000
...
0x030 + 0x4 * 7	Endpoint Control and Status Register 7	UDP_CSR7	Read-write	0x0000_0000
0x050	Endpoint FIFO Data Register 0	UDP_FDR0	Read-write	0x0000_0000
...
0x050 + 0x4 * 7	Endpoint FIFO Data Register 7	UDP_FDR7	Read-write	0x0000_0000
0x070	Reserved	–	–	–
0x074	Transceiver Control Register	UDP_TXVC ⁽²⁾	Read-write	0x0000_0100
0x078 - 0xFC	Reserved	–	–	–

- Notes: 1. Reset values are not defined for UDP_ISR.
 2. See Warning above the "Register Mapping" on this page.

38.7.1 UDP Frame Number Register

Name: UDP_FRM_NUM

Address: 0x40034000

Access: Read-only

31	30	29	28	27	26	25	24
---	---	---	---	---	---	---	---
23	22	21	20	19	18	17	16
-	-	-	-	-	-	FRM_OK	FRM_ERR
15	14	13	12	11	10	9	8
-	-	-	-	-	FRM_NUM		
7	6	5	4	3	2	1	0
FRM_NUM							

- **FRM_NUM[10:0]: Frame Number as Defined in the Packet Field Formats**

This 11-bit value is incremented by the host on a per frame basis. This value is updated at each start of frame.

Value Updated at the SOF_EOP (Start of Frame End of Packet).

- **FRM_ERR: Frame Error**

This bit is set at SOF_EOP when the SOF packet is received containing an error.

This bit is reset upon receipt of SOF_PID.

- **FRM_OK: Frame OK**

This bit is set at SOF_EOP when the SOF packet is received without any error.

This bit is reset upon receipt of SOF_PID (Packet Identification).

In the Interrupt Status Register, the SOF interrupt is updated upon receiving SOF_PID. This bit is set without waiting for EOP.

Note: In the 8-bit Register Interface, FRM_OK is bit 4 of FRM_NUM_H and FRM_ERR is bit 3 of FRM_NUM_L.

38.7.2 UDP Global State Register

Name: UDP_GLB_STAT

Address: 0x40034004

Access: Read-write

31	30	29	28	27	26	25	24
–	–	–	–	–	–	–	–
23	22	21	20	19	18	17	16
–	–	–	–	–	–	–	–
15	14	13	12	11	10	9	8
–	–	–	–	–	–	–	–
7	6	5	4	3	2	1	0
–	–	–	RMWUPE	RSMINPR	ESR	CONFIG	FADDEN

This register is used to get and set the device state as specified in Chapter 9 of the *USB Serial Bus Specification, Rev.2.0*.

- **FADDEN: Function Address Enable**

Read:

0 = Device is not in address state.

1 = Device is in address state.

Write:

0 = No effect, only a reset can bring back a device to the default state.

1 = Sets device in address state. This occurs after a successful Set Address request. Beforehand, the UDP_FADDR register must have been initialized with Set Address parameters. Set Address must complete the Status Stage before setting FADDEN. Refer to chapter 9 of the *Universal Serial Bus Specification, Rev. 2.0* for more details.

- **CONFIG: Configured**

Read:

0 = Device is not in configured state.

1 = Device is in configured state.

Write:

0 = Sets device in a non configured state

1 = Sets device in configured state.

The device is set in configured state when it is in address state and receives a successful Set Configuration request. Refer to Chapter 9 of the *Universal Serial Bus Specification, Rev. 2.0* for more details.

- **ESR: Enable Send Resume**

0 = Mandatory value prior to starting any Remote Wake Up procedure.

1 = Starts the Remote Wake Up procedure if this bit value was 0 and if RMWUPE is enabled.

- **RMWUPE: Remote Wake Up Enable**

0 = The Remote Wake Up feature of the device is disabled.

1 = The Remote Wake Up feature of the device is enabled.

38.7.3 UDP Function Address Register

Name: UDP_FADDR

Address: 0x40034008

Access: Read-write

31	30	29	28	27	26	25	24
–	–	–	–	–	–	–	–
23	22	21	20	19	18	17	16
–	–	–	–	–	–	–	–
15	14	13	12	11	10	9	8
–	–	–	–	–	–	–	FEN
7	6	5	4	3	2	1	0
–	FADD						

- **FADD[6:0]: Function Address Value**

The Function Address Value must be programmed by firmware once the device receives a set address request from the host, and has achieved the status stage of the no-data control sequence. Refer to the *Universal Serial Bus Specification, Rev. 2.0* for more information. After power up or reset, the function address value is set to 0.

- **FEN: Function Enable**

Read:

0 = Function endpoint disabled.

1 = Function endpoint enabled.

Write:

0 = Disables function endpoint.

1 = Default value.

The Function Enable bit (FEN) allows the microcontroller to enable or disable the function endpoints. The microcontroller sets this bit after receipt of a reset from the host. Once this bit is set, the USB device is able to accept and transfer data packets from and to the host.

38.7.4 UDP Interrupt Enable Register

Name: UDP_IER
Address: 0x40034010
Access: Write-only

31	30	29	28	27	26	25	24
–	–	–	–	–	–	–	–
23	22	21	20	19	18	17	16
–	–	–	–	–	–	–	–
15	14	13	12	11	10	9	8
–	–	WAKEUP	–	SOFINT	EXTRSM	RXRSM	RXSUSP
7	6	5	4	3	2	1	0
EP7INT	EP6INT	EP5INT	EP4INT	EP3INT	EP2INT	EP1INT	EPOINT

- **EP0INT: Enable Endpoint 0 Interrupt**
 - **EP1INT: Enable Endpoint 1 Interrupt**
 - **EP2INT: Enable Endpoint 2 Interrupt**
 - **EP3INT: Enable Endpoint 3 Interrupt**
 - **EP4INT: Enable Endpoint 4 Interrupt**
 - **EP5INT: Enable Endpoint 5 Interrupt**
 - **EP6INT: Enable Endpoint 6 Interrupt**
 - **EP7INT: Enable Endpoint 7 Interrupt**
- 0 = No effect.
 1 = Enables corresponding Endpoint Interrupt.
- **RXSUSP: Enable UDP Suspend Interrupt**
- 0 = No effect.
 1 = Enables UDP Suspend Interrupt.
- **RXRSM: Enable UDP Resume Interrupt**
- 0 = No effect.
 1 = Enables UDP Resume Interrupt.
- **SOFINT: Enable Start Of Frame Interrupt**
- 0 = No effect.
 1 = Enables Start Of Frame Interrupt.
- **WAKEUP: Enable UDP bus Wakeup Interrupt**
- 0 = No effect.
 1 = Enables USB bus Interrupt.

38.7.5 UDP Interrupt Disable Register

Name: UDP_IDR
Address: 0x40034014
Access: Write-only

31	30	29	28	27	26	25	24
–	–	–	–	–	–	–	–
23	22	21	20	19	18	17	16
–	–	–	–	–	–	–	–
15	14	13	12	11	10	9	8
–	–	WAKEUP	–	SOFINT	EXTRSM	RXRSM	RXSUSP
7	6	5	4	3	2	1	0
EP7INT	EP6INT	EP5INT	EP4INT	EP3INT	EP2INT	EP1INT	EPOINT

- **EP0INT: Disable Endpoint 0 Interrupt**
 - **EP1INT: Disable Endpoint 1 Interrupt**
 - **EP2INT: Disable Endpoint 2 Interrupt**
 - **EP3INT: Disable Endpoint 3 Interrupt**
 - **EP4INT: Disable Endpoint 4 Interrupt**
 - **EP5INT: Disable Endpoint 5 Interrupt**
 - **EP6INT: Disable Endpoint 6 Interrupt**
 - **EP7INT: Disable Endpoint 7 Interrupt**
- 0 = No effect.
 1 = Disables corresponding Endpoint Interrupt.
- **RXSUSP: Disable UDP Suspend Interrupt**
- 0 = No effect.
 1 = Disables UDP Suspend Interrupt.
- **RXRSM: Disable UDP Resume Interrupt**
- 0 = No effect.
 1 = Disables UDP Resume Interrupt.
- **SOFINT: Disable Start Of Frame Interrupt**
- 0 = No effect.
 1 = Disables Start Of Frame Interrupt
- **WAKEUP: Disable USB Bus Interrupt**
- 0 = No effect.
 1 = Disables USB Bus Wakeup Interrupt.

38.7.6 UDP Interrupt Mask Register

Name: UDP_IMR

Address: 0x40034018

Access: Read-only

31	30	29	28	27	26	25	24
–	–	–	–	–	–	–	–
23	22	21	20	19	18	17	16
–	–	–	–	–	–	–	–
15	14	13	12	11	10	9	8
–	–	WAKEUP	BIT12	SOFINT	EXTRSM	RXRSM	RXSUSP
7	6	5	4	3	2	1	0
EP7INT	EP6INT	EP5INT	EP4INT	EP3INT	EP2INT	EP1INT	EPOINT

- **EP0INT: Mask Endpoint 0 Interrupt**
- **EP1INT: Mask Endpoint 1 Interrupt**
- **EP2INT: Mask Endpoint 2 Interrupt**
- **EP3INT: Mask Endpoint 3 Interrupt**
- **EP4INT: Mask Endpoint 4 Interrupt**
- **EP5INT: Mask Endpoint 5 Interrupt**
- **EP6INT: Mask Endpoint 6 Interrupt**
- **EP7INT: Mask Endpoint 7 Interrupt**

0 = Corresponding Endpoint Interrupt is disabled.

1 = Corresponding Endpoint Interrupt is enabled.

- **RXSUSP: Mask UDP Suspend Interrupt**

0 = UDP Suspend Interrupt is disabled.

1 = UDP Suspend Interrupt is enabled.

- **RXRSM: Mask UDP Resume Interrupt.**

0 = UDP Resume Interrupt is disabled.

1 = UDP Resume Interrupt is enabled.

- **SOFINT: Mask Start Of Frame Interrupt**

0 = Start of Frame Interrupt is disabled.

1 = Start of Frame Interrupt is enabled.

- **BIT12: UDP_IMR Bit 12**

Bit 12 of UDP_IMR cannot be masked and is always read at 1.



- **WAKEUP: USB Bus WAKEUP Interrupt**

0 = USB Bus Wakeup Interrupt is disabled.

1 = USB Bus Wakeup Interrupt is enabled.

Note: When the USB block is in suspend mode, the application may power down the USB logic. In this case, any USB HOST resume request that is made must be taken into account and, thus, the reset value of the RXRSM bit of the register UDP_IMR is enabled.

38.7.7 UDP Interrupt Status Register

Name: UDP_ISR

Address: 0x4003401C

Access: Read-only

31	30	29	28	27	26	25	24
–	–	–	–	–	–	–	–
23	22	21	20	19	18	17	16
–	–	–	–	–	–	–	–
15	14	13	12	11	10	9	8
–	–	WAKEUP	ENDBUSRES	SOFINT	EXTRSM	RXRSM	RXSUSP
7	6	5	4	3	2	1	0
EP7INT	EP6INT	EP5INT	EP4INT	EP3INT	EP2INT	EP1INT	EP0INT

- **EP0INT: Endpoint 0 Interrupt Status**
- **EP1INT: Endpoint 1 Interrupt Status**
- **EP2INT: Endpoint 2 Interrupt Status**
- **EP3INT: Endpoint 3 Interrupt Status**
- **EP4INT: Endpoint 4 Interrupt Status**
- **EP5INT: Endpoint 5 Interrupt Status**
- **EP6INT: Endpoint 6 Interrupt Status**
- **EP7INT: Endpoint 7 Interrupt Status**

0 = No Endpoint0 Interrupt pending.

1 = Endpoint0 Interrupt has been raised.

Several signals can generate this interrupt. The reason can be found by reading UDP_CSR0:

RXSETUP set to 1

RX_DATA_BK0 set to 1

RX_DATA_BK1 set to 1

TXCOMP set to 1

STALLSENT set to 1

EP0INT is a sticky bit. Interrupt remains valid until EP0INT is cleared by writing in the corresponding UDP_CSR0 bit.

- **RXSUSP: UDP Suspend Interrupt Status**

0 = No UDP Suspend Interrupt pending.

1 = UDP Suspend Interrupt has been raised.

The USB device sets this bit when it detects no activity for 3ms. The USB device enters Suspend mode.

- **RXRSM: UDP Resume Interrupt Status**

0 = No UDP Resume Interrupt pending.

1 =UDP Resume Interrupt has been raised.

The USB device sets this bit when a UDP resume signal is detected at its port.

After reset, the state of this bit is undefined, the application must clear this bit by setting the RXRSM flag in the UDP_ICR register.

- **SOFINT: Start of Frame Interrupt Status**

0 = No Start of Frame Interrupt pending.

1 = Start of Frame Interrupt has been raised.

This interrupt is raised each time a SOF token has been detected. It can be used as a synchronization signal by using isochronous endpoints.

- **ENDBUSRES: End of BUS Reset Interrupt Status**

0 = No End of Bus Reset Interrupt pending.

1 = End of Bus Reset Interrupt has been raised.

This interrupt is raised at the end of a UDP reset sequence. The USB device must prepare to receive requests on the endpoint 0. The host starts the enumeration, then performs the configuration.

- **WAKEUP: UDP Resume Interrupt Status**

0 = No Wakeup Interrupt pending.

1 = A Wakeup Interrupt (USB Host Sent a RESUME or RESET) occurred since the last clear.

After reset the state of this bit is undefined, the application must clear this bit by setting the WAKEUP flag in the UDP_ICR register.

38.7.8 UDP Interrupt Clear Register

Name: UDP_ICR

Address: 0x40034020

Access: Write-only

31	30	29	28	27	26	25	24
–	–	–	–	–	–	–	–
23	22	21	20	19	18	17	16
–	–	–	–	–	–	–	–
15	14	13	12	11	10	9	8
–	–	WAKEUP	ENDBUSRES	SOFINT	EXTRSM	RXRSM	RXSUSP
7	6	5	4	3	2	1	0
–	–	–	–	–	–	–	–

- **RXSUSP: Clear UDP Suspend Interrupt**

0 = No effect.

1 = Clears UDP Suspend Interrupt.

- **RXRSM: Clear UDP Resume Interrupt**

0 = No effect.

1 = Clears UDP Resume Interrupt.

- **SOFINT: Clear Start Of Frame Interrupt**

0 = No effect.

1 = Clears Start Of Frame Interrupt.

- **ENDBUSRES: Clear End of Bus Reset Interrupt**

0 = No effect.

1 = Clears End of Bus Reset Interrupt.

- **WAKEUP: Clear Wakeup Interrupt**

0 = No effect.

1 = Clears Wakeup Interrupt.

38.7.9 UDP Reset Endpoint Register

Name: UDP_RST_EP

Address: 0x40034028

Access: Read-write

31	30	29	28	27	26	25	24
–	–	–	–	–	–	–	–
23	22	21	20	19	18	17	16
–	–	–	–	–	–	–	–
15	14	13	12	11	10	9	8
–	–	–	–	–	–	–	–
7	6	5	4	3	2	1	0
EP7	EP6	EP5	EP4	EP3	EP2	EP1	EP0

- **EP0: Reset Endpoint 0**
- **EP1: Reset Endpoint 1**
- **EP2: Reset Endpoint 2**
- **EP3: Reset Endpoint 3**
- **EP4: Reset Endpoint 4**
- **EP5: Reset Endpoint 5**
- **EP6: Reset Endpoint 6**
- **EP7: Reset Endpoint 7**

This flag is used to reset the FIFO associated with the endpoint and the bit RXBYTECOUNT in the register UDP_CSRx. It also resets the data toggle to DATA0. It is useful after removing a HALT condition on a BULK endpoint. Refer to Chapter 5.8.5 in the *USB Serial Bus Specification, Rev.2.0*.

Warning: This flag must be cleared at the end of the reset. It does not clear UDP_CSRx flags.

0 = No reset.

1 = Forces the corresponding endpoint FIFO pointers to 0, therefore RXBYTECNT field is read at 0 in UDP_CSRx register.

Resetting the endpoint is a two-step operation:

1. Set the corresponding EPx field.
2. Clear the corresponding EPx field.

38.7.10 UDP Endpoint Control and Status Register

Name: UDP_CSRx [x = 0..7]

Address: 0x40034030

Access: Read-write

31	30	29	28	27	26	25	24
–	–	–	–	–	RXBYTECNT		
23	22	21	20	19	18	17	16
RXBYTECNT							
15	14	13	12	11	10	9	8
EPEDS	–	–	–	DTGLE	EPTYPE		
7	6	5	4	3	2	1	0
DIR	RX_DATA_BK1	FORCESTALL	TXPKTRDY	STALLSENT/ ISOERROR	RXSETUP	RX_DATA_BK0	TXCOMP

WARNING: Due to synchronization between MCK and UDPCK, the software application must wait for the end of the write operation before executing another write by polling the bits which must be set/cleared.

```

#if defined ( __ICCARM__ )
    #define nop() ( __no_operation() )

#elif defined ( __GNUC__ )
    #define nop() __asm__ __volatile__ ( "nop" )

#endif

// Bitmap for all status bits in CSR that are not effected by a value 1.
#define REG_NO_EFFECT_1_ALL    AT91C_UDP_RX_DATA_BK0\
                               | AT91C_UDP_RX_DATA_BK1\
                               | AT91C_UDP_STALLSENT\
                               | AT91C_UDP_RXSETUP\
                               | AT91C_UDP_TXCOMP

// Sets the specified bit(s) in the UDP_CSR register.
// \param endpoint The endpoint number of the CSR to process.
// \param flags The bitmap to set to 1.
#define SET_CSR(endpoint, flags) \
{ \
    volatile unsigned int reg; \
    reg = AT91C_BASE_UDP->UDP_CSR[endpoint] ; \
    reg |= REG_NO_EFFECT_1_ALL; \
    reg |= (flags); \
    AT91C_BASE_UDP->UDP_CSR[endpoint] = reg; \
    for( nop_count=0; nop_count<15; nop_count++ ) {\
        nop();\
    }

```

```

    }\
}

// Clears the specified bit(s) in the UDP_CSR register.
// \param endpoint The endpoint number of the CSR to process.
// \param flags The bitmap to clear to 0.
#define CLEAR_CSR(endpoint, flags) \
{ \
    volatile unsigned int reg; \
    reg = AT91C_BASE_UDP->UDP_CSR[endpoint]; \
    reg |= REG_NO_EFFECT_1_ALL; \
    reg &= ~(flags); \
    AT91C_BASE_UDP->UDP_CSR[endpoint] = reg; \
    for( nop_count=0; nop_count<15; nop_count++ ) {\
        nop();\
    }\
}

```

In a preemptive environment, set or clear the flag and wait for a time of 1 UDPCK clock cycle and 1 peripheral clock cycle. However, RX_DATA_BK0, TXPKTRDY, RX_DATA_BK1 require wait times of 3 UDPCK clock cycles and 5 peripheral clock cycles before accessing DPR.

- **TXCOMP: Generates an IN Packet with Data Previously Written in the DPR**

This flag generates an interrupt while it is set to one.

Write (Cleared by the firmware):

0 = Clear the flag, clear the interrupt.

1 = No effect.

Read (Set by the USB peripheral):

0 = Data IN transaction has not been acknowledged by the Host.

1 = Data IN transaction is achieved, acknowledged by the Host.

After having issued a Data IN transaction setting TXPKTRDY, the device firmware waits for TXCOMP to be sure that the host has acknowledged the transaction.

- **RX_DATA_BK0: Receive Data Bank 0**

This flag generates an interrupt while it is set to one.

Write (Cleared by the firmware):

0 = Notify USB peripheral device that data have been read in the FIFO's Bank 0.

1 = To leave the read value unchanged.

Read (Set by the USB peripheral):

0 = No data packet has been received in the FIFO's Bank 0.

1 = A data packet has been received, it has been stored in the FIFO's Bank 0.

When the device firmware has polled this bit or has been interrupted by this signal, it must transfer data from the FIFO to the microcontroller memory. The number of bytes received is available in RXBYTCENT field. Bank 0 FIFO values are read

through the UDP_FDRx register. Once a transfer is done, the device firmware must release Bank 0 to the USB peripheral device by clearing RX_DATA_BK0.

After setting or clearing this bit, a wait time of 3 UDPCCK clock cycles and 3 peripheral clock cycles is required before accessing DPR.

- **RXSETUP: Received Setup**

This flag generates an interrupt while it is set to one.

Read:

0 = No setup packet available.

1 = A setup data packet has been sent by the host and is available in the FIFO.

Write:

0 = Device firmware notifies the USB peripheral device that it has read the setup data in the FIFO.

1 = No effect.

This flag is used to notify the USB device firmware that a valid Setup data packet has been sent by the host and successfully received by the USB device. The USB device firmware may transfer Setup data from the FIFO by reading the UDP_FDRx register to the microcontroller memory. Once a transfer has been done, RXSETUP must be cleared by the device firmware.

Ensuing Data OUT transaction is not accepted while RXSETUP is set.

- **STALLSENT: Stall Sent (Control, Bulk Interrupt Endpoints)/ISOERROR (Isochronous Endpoints)**

This flag generates an interrupt while it is set to one.

STALLSENT: This ends a STALL handshake.

Read:

0 = The host has not acknowledged a STALL.

1 = Host has acknowledged the stall.

Write:

0 = Resets the STALLSENT flag, clears the interrupt.

1 = No effect.

This is mandatory for the device firmware to clear this flag. Otherwise the interrupt remains.

Refer to chapters 8.4.5 and 9.4.5 of the *Universal Serial Bus Specification, Rev. 2.0* for more information on the STALL handshake.

ISOERROR: A CRC error has been detected in an isochronous transfer.

Read:

0 = No error in the previous isochronous transfer.

1 = CRC error has been detected, data available in the FIFO are corrupted.

Write:

0 = Resets the ISOERROR flag, clears the interrupt.

1 = No effect.

- **TXPKTRDY: Transmit Packet Ready**

This flag is cleared by the USB device.

This flag is set by the USB device firmware.

Read:

0 = There is no data to send.

1 = The data is waiting to be sent upon reception of token IN.

Write:

0 = Can be used in the procedure to cancel transmission data. (See, [Section 38.6.2.5 “Transmit Data Cancellation” on page 993](#))

1 = A new data payload has been written in the FIFO by the firmware and is ready to be sent.

This flag is used to generate a Data IN transaction (device to host). Device firmware checks that it can write a data payload in the FIFO, checking that TXPKTRDY is cleared. Transfer to the FIFO is done by writing in the UDP_FDRx register. Once the data payload has been transferred to the FIFO, the firmware notifies the USB device setting TXPKTRDY to one. USB bus transactions can start. TXCOMP is set once the data payload has been received by the host.

After setting or clearing this bit, a wait time of 3 UDPOCK clock cycles and 3 peripheral clock cycles is required before accessing DPR.

- **FORCESTALL: Force Stall (used by Control, Bulk and Isochronous Endpoints)**

Read:

0 = Normal state.

1 = Stall state.

Write:

0 = Return to normal state.

1 = Send STALL to the host.

Refer to chapters 8.4.5 and 9.4.5 of the *Universal Serial Bus Specification, Rev. 2.0* for more information on the STALL handshake.

Control endpoints: During the data stage and status stage, this bit indicates that the microcontroller cannot complete the request.

Bulk and interrupt endpoints: This bit notifies the host that the endpoint is halted.

The host acknowledges the STALL, device firmware is notified by the STALLSENT flag.

- **RX_DATA_BK1: Receive Data Bank 1 (only used by endpoints with ping-pong attributes)**

This flag generates an interrupt while it is set to one.

Write (Cleared by the firmware):

0 = Notifies USB device that data have been read in the FIFO's Bank 1.

1 = To leave the read value unchanged.

Read (Set by the USB peripheral):

0 = No data packet has been received in the FIFO's Bank 1.

1 = A data packet has been received, it has been stored in FIFO's Bank 1.

When the device firmware has polled this bit or has been interrupted by this signal, it must transfer data from the FIFO to microcontroller memory. The number of bytes received is available in RXBYTECNT field. Bank 1 FIFO values are read through UDP_FDRx register. Once a transfer is done, the device firmware must release Bank 1 to the USB device by clearing RX_DATA_BK1.

After setting or clearing this bit, a wait time of 3 UDPCCK clock cycles and 3 peripheral clock cycles is required before accessing DPR.

- **DIR: Transfer Direction (only available for control endpoints)**

Read-write

0 = Allows Data OUT transactions in the control data stage.

1 = Enables Data IN transactions in the control data stage.

Refer to Chapter 8.5.3 of the *Universal Serial Bus Specification, Rev. 2.0* for more information on the control data stage.

This bit must be set before UDP_CSRx/RXSETUP is cleared at the end of the setup stage. According to the request sent in the setup data packet, the data stage is either a device to host (DIR = 1) or host to device (DIR = 0) data transfer. It is not necessary to check this bit to reverse direction for the status stage.

- **EPTYPE[2:0]: Endpoint Type**

Read-Write

Value	Name	Description
000	CTRL	Control
001	ISO_OUT	Isochronous OUT
101	ISO_IN	Isochronous IN
010	BULK_OUT	Bulk OUT
110	BULK_IN	Bulk IN
011	INT_OUT	Interrupt OUT
111	INT_IN	Interrupt IN

- **DTGLE: Data Toggle**

Read-only

0 = Identifies DATA0 packet.

1 = Identifies DATA1 packet.

Refer to Chapter 8 of the *Universal Serial Bus Specification, Rev. 2.0* for more information on DATA0, DATA1 packet definitions.

- **EPEDS: Endpoint Enable Disable**

Read:

0 = Endpoint disabled.

1 = Endpoint enabled.

Write:

0 = Disables endpoint.

1 = Enables endpoint.



Control endpoints are always enabled. Reading or writing this field has no effect on control endpoints.

Note: After reset, all endpoints are configured as control endpoints (zero).

- **RXBYTECNT[10:0]: Number of Bytes Available in the FIFO**

Read-only

When the host sends a data packet to the device, the USB device stores the data in the FIFO and notifies the microcontroller. The microcontroller can load the data from the FIFO by reading RXBYTECENT bytes in the UDP_FDRx register.

38.7.11 UDP FIFO Data Register

Name: UDP_FDRx [x = 0..7]

Address: 0x40034050

Access: Read-write

31	30	29	28	27	26	25	24
–	–	–	–	–	–	–	–
23	22	21	20	19	18	17	16
–	–	–	–	–	–	–	–
15	14	13	12	11	10	9	8
–	–	–	–	–	–	–	–
7	6	5	4	3	2	1	0
FIFO_DATA							

- **FIFO_DATA[7:0]: FIFO Data Value**

The microcontroller can push or pop values in the FIFO through this register.

RXBYTECNT in the corresponding UDP_CSRx register is the number of bytes to be read from the FIFO (sent by the host).

The maximum number of bytes to write is fixed by the Max Packet Size in the Standard Endpoint Descriptor. It can not be more than the physical memory size associated to the endpoint. Refer to the *Universal Serial Bus Specification, Rev. 2.0* for more information.



38.7.12 UDP Transceiver Control Register

Name: UDP_TXVC
Address: 0x40034074
Access: Read-write

31	30	29	28	27	26	25	24
–	–	–	–	–	–	–	–
23	22	21	20	19	18	17	16
–	–	–	–	–	–	–	–
15	14	13	12	11	10	9	8
–	–	–	–	–	–	PUON	TXVDIS
7	6	5	4	3	2	1	0
–	–	–	–	–	–	–	–

WARNING: The UDP peripheral clock in the Power Management Controller (PMC) must be enabled before any read/write operations to the UDP registers including the UDP_TXVC register.

- **TXVDIS: Transceiver Disable**

When UDP is disabled, power consumption can be reduced significantly by disabling the embedded transceiver. This can be done by setting TXVDIS field.

To enable the transceiver, TXVDIS must be cleared.

- **PUON: Pullup On**

0: The 1.5KΩ integrated pullup on DDP is disconnected.

1: The 1.5 KΩ integrated pullup on DDP is connected.

NOTE: If the USB pullup is not connected on DDP, the user should not write in any UDP register other than the UDP_TXVC register. This is because if DDP and DDM are floating at 0, or pulled down, then SE0 is received by the device with the consequence of a USB Reset.

39. Analog Comparator Controller (ACC)

39.1 Description

The Analog Comparator Controller (ACC) configures the Analog Comparator and generates an interrupt according to the user settings. The analog comparator embeds 8 to 1 multiplexers on both inputs.

The Analog Comparator compares two voltages and the result of this comparison gives a compare output. The user can select a high-speed or low-power option. Additionally, the hysteresis level, edge detection and polarity are configurable.

The ACC can also generate a compare event which can be used by the PWM.

Refer to [Figure 39-1 on page 1018](#) for detailed schematics.

39.2 Embedded Characteristics

- 8 User Analog Inputs Selectable for Comparison
- 4 Voltage References Selectable for Comparison: Temperature Sensor, ADVREF, DAC0 and DAC1
- Interrupt Generation
- Compare Event Fault Generation for PWM

39.3 Block Diagram

Figure 39-1. Analog Comparator Controller Block Diagram

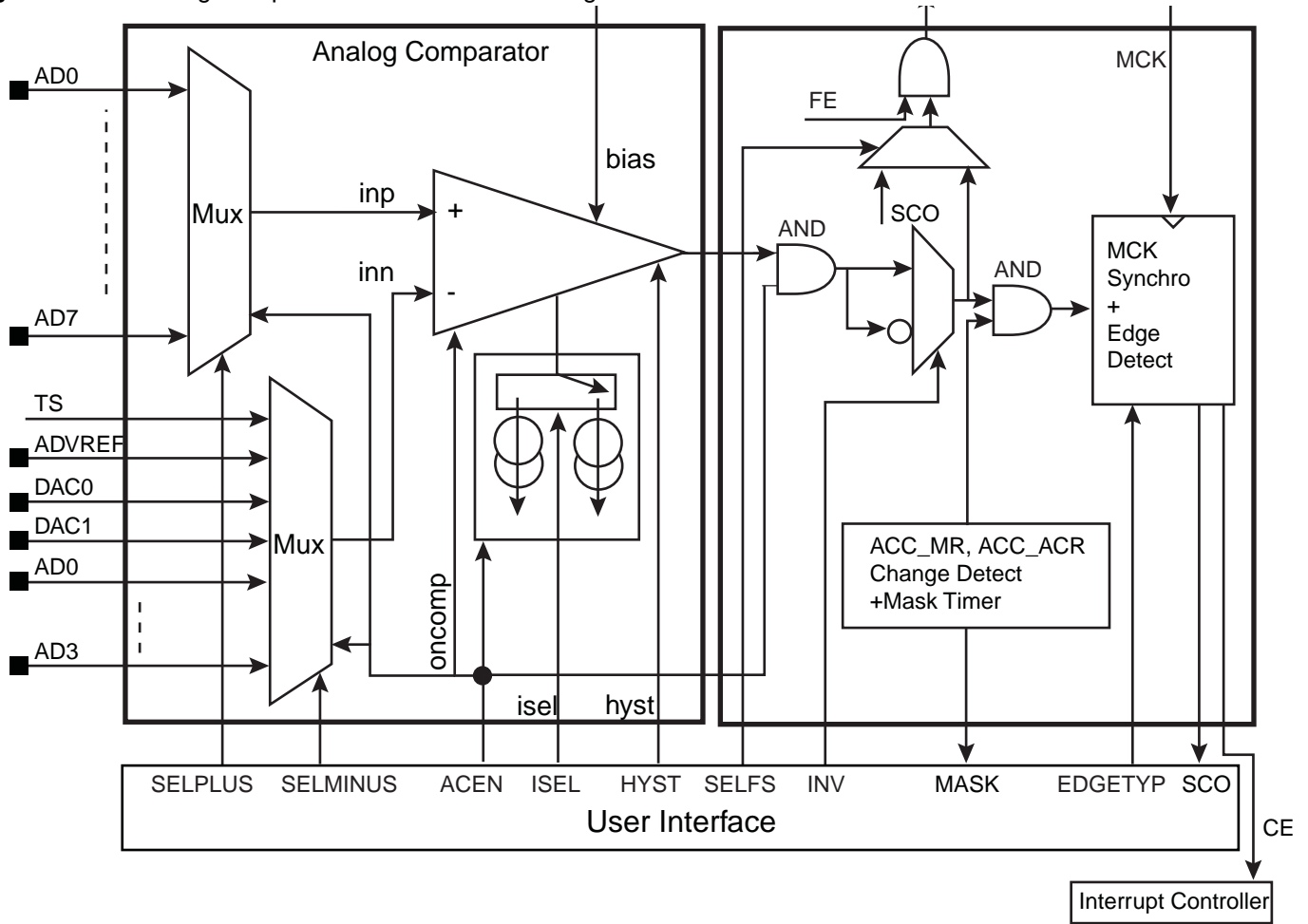

39.4 Pin Name List**Table 39-1.** ACC Pin List

Pin Name	Description	Type
AD0..AD7	Analog Inputs	Input
TS	On-Chip Temperature Sensor	Input
ADVREF	ADC Voltage Reference.	Input
DAC0, DAC1	On-Chip DAC Outputs	Input
FAULT	Drives internal fault input of PWM	Output

39.5 Product Dependencies

39.5.1 I/O Lines

The analog input pins (AD0-AD7 and DAC0-1) are multiplexed with PIO lines. In this case, the assignment of the ACC inputs is automatically done as soon as the corresponding input is enabled by writing the ACC Mode register (SELMINUS and SELPLUS).

39.5.2 Power Management

The ACC is clocked through the Power Management Controller (PMC), thus the programmer must first configure the PMC to enable the Analog Comparator Controller clock.

Note that the voltage regulator needs to be activated to use the Analog Comparator.

39.5.3 Interrupt

The ACC has an interrupt line connected to the Interrupt Controller (IC). Handling the ACC interrupt requires programming the Interrupt Controller before configuring the ACC.

Table 39-2. Peripheral IDs

Instance	ID
ACC	33

39.5.4 Fault Output

The ACC has the FAULT output connected to the FAULT input of PWM. Please refer to chapter [Section 39.6.5 "Fault Mode"](#) and implementation of the PWM in the product.

39.6 Functional Description

39.6.1 ACC Description

The Analog Comparator Controller mainly controls the analog comparator settings. There is also post processing of the analog comparator output.

The output of the analog comparator is masked for the time the output may be invalid. This situation is encountered as soon as the analog comparator settings are modified.

A comparison flag is triggered by an event on the output of the analog comparator and an interrupt can be generated accordingly. The event on the analog comparator output can be selected among falling edge, rising edge or any edge.

The registers for programming are listed in [Table 39-3 on page 1022](#).

39.6.2 Analog Settings

The user can select the input hysteresis and configure high-speed or low-speed options.

- shortest propagation delay/highest current consumption
- longest propagation delay/lowest current consumption

39.6.3 Write Protection System

In order to provide security to the Analog Comparator Controller, a write protection system has been implemented.

The write protection mode prevents writing [ACC Mode Register](#) and [ACC Analog Control Register](#). When this mode is enabled and one of the protected registers is written, the register write request is canceled.

Due to the nature of the write protection feature, enabling and disabling the write protection mode requires a security code. Thus when enabling or disabling the write protection mode, the WPKEY field of the ACC_WPMR register must be filled with the "ACC" ASCII code (corresponding to 0x414343), otherwise the register write will be canceled.

39.6.4 Automatic Output Masking Period

As soon as the analog comparator settings change, the output is invalid for a duration depending on ISEL current.

A masking period is automatically triggered as soon as a write access is performed on ACC_MR or ACC_ACR registers (whatever the register data content).

When ISEL = 0, the mask period is $8 \cdot tMCK$, else $128 \cdot tMCK$.

The masking period is reported by reading a negative value (bit 31 set) on ACC_ISR register

39.6.5 Fault Mode

The FAULT output can be used to propagate a comparison match and act immediately via combinatorial logic by using the FAULT output which is directly connected to the FAULT input of the PWM.

The source of the FAULT output can be configured to be either a combinational value derived from the analog comparator output or the MCK resynchronized value (Refer to [Figure 39-1 "Analog Comparator Controller Block Diagram"](#)).

39.7 Analog Comparator Controller (ACC) User Interface

Table 39-3. Register Mapping

Offset	Register	Name	Access	Reset
0x00	Control Register	ACC_CR	Write-only	
0x04	Mode Register	ACC_MR	Read-write	0
0x08-0x20	Reserved			
0x24	Interrupt Enable Register	ACC_IER	Write-only	
0x28	Interrupt Disable Register	ACC_IDR	Write-only	
0x2C	Interrupt Mask Register	ACC_IMR	Read-only	0
0x30	Interrupt Status Register	ACC_ISR	Read-only	0
0x34-0x90	Reserved			
0x94	Analog Control Register	ACC_ACR	Read-write	0
0x98-0xE0	Reserved			
0xE4	Write Protect Mode Register	ACC_WPMR	Read-write	0
0xE8	Write Protect Status Register	ACC_WPSR	Read-only	0
0xEC-0xF8	Reserved			
0xFC	Reserved	–	–	–

39.7.1 ACC Control Register

Name: ACC_CR
Address: 0x40040000
Access: Write-only

31	30	29	28	27	26	25	24
–	–	–	–	–	–	–	–
23	22	21	20	19	18	17	16
–	–	–	–	–	–	–	–
15	14	13	12	11	10	9	8
–	–	–	–	–	–	–	–
7	6	5	4	3	2	1	0
–	–	–	–	–	–	–	SWRST

- **SWRST: SoftWare ReSeT**

0 = No effect.

1 = Resets the module.

39.7.2 ACC Mode Register

Name: ACC_MR
Address: 0x40040004
Access: Read-write

31	30	29	28	27	26	25	24
–	–	–	–	–	–	–	–
23	22	21	20	19	18	17	16
–	–	–	–	–	–	–	–
15	14	13	12	11	10	9	8
–	FE	SELFS	INV	–	EDGETYP	–	ACEN
7	6	5	4	3	2	1	0
–	SELPLUS			–	SELMINUS		

This register can only be written if the WPEN bit is cleared in the [ACC Write Protect Mode Register](#).

- **SELMINUS: SElection for MINUS comparator input**

0..7 = Selects the input to apply on analog comparator SELMINUS comparison input.

Value	Name	Description
0	TS	SelectTS
1	ADVREF	Select ADVREF
2	DAC0	Select DAC0
3	DAC1	Select DAC1
4	AD0	Select AD0
5	AD1	Select AD1
6	AD2	Select AD2
7	AD3	Select AD3

- **SELPLUS: SElection for PLUS comparator input**

0..7 = selects the input to apply on analog comparator SELPLUS comparison input.

Value	Name	Description
0	AD0	Select AD0
1	AD1	Select AD1
2	AD2	Select AD2
3	AD3	Select AD3
4	AD4	Select AD4
5	AD5	Select AD5
6	AD6	Select AD6
7	AD7	Select AD7

- **ACEN: Analog Comparator ENable**

0 (DIS) = Analog Comparator Disabled.

1 (EN) = Analog Comparator Enabled.

- **EDGETYP: EDGE TYPEe**

Value	Name	Description
0	RISING	only rising edge of comparator output
1	FALLING	falling edge of comparator output
2	ANY	any edge of comparator output

- **INV: INVert comparator output**

0 (DIS) = Analog Comparator output is directly processed.

1 (EN) = Analog Comparator output is inverted prior to being processed.

- **SELFS: SElection of Fault Source**

0 (CF) = The CF flag is used to drive the FAULT output.

1 (OUTPUT) = The output of the Analog Comparator flag is used to drive the FAULT output.

- **FE: Fault Enable**

0 (DIS) = The FAULT output is tied to 0.

1 (EN) = The FAULT output is driven by the signal defined by SELFS.



39.7.3 ACC Interrupt Enable Register

Name: ACC_IER

Address: 0x40040024

Access: Write-only

31	30	29	28	27	26	25	24
–	–	–	–	–	–	–	–
23	22	21	20	19	18	17	16
–	–	–	–	–	–	–	–
15	14	13	12	11	10	9	8
–	–	–	–	–	–	–	–
7	6	5	4	3	2	1	0
–	–	–	–	–	–	–	CE

- **CE: Comparison Edge**

0 = No effect.

1 = Enables the interruption when the selected edge (defined by EDGETYP) occurs.



39.7.4 ACC Interrupt Disable Register

Name: ACC_IDR

Address: 0x40040028

Access: Write-only

31	30	29	28	27	26	25	24
–	–	–	–	–	–	–	–
23	22	21	20	19	18	17	16
–	–	–	–	–	–	–	–
15	14	13	12	11	10	9	8
–	–	–	–	–	–	–	–
7	6	5	4	3	2	1	0
–	–	–	–	–	–	–	CE

- **CE: Comparison Edge**

0 = No effect.

1 = Disables the interruption when the selected edge (defined by EDGETYP) occurs.

39.7.5 ACC Interrupt Mask Register

Name: ACC_IMR

Address: 0x4004002C

Access: Read-only

31	30	29	28	27	26	25	24
–	–	–	–	–	–	–	–
23	22	21	20	19	18	17	16
–	–	–	–	–	–	–	–
15	14	13	12	11	10	9	8
–	–	–	–	–	–	–	–
7	6	5	4	3	2	1	0
–	–	–	–	–	–	–	CE

- **CE: Comparison Edge**

0 = The interruption is disabled.

1 = The interruption is enabled.

39.7.6 ACC Interrupt Status Register

Name: ACC_ISR
Address: 0x40040030
Access: Read-only

31	30	29	28	27	26	25	24
MASK	–	–	–	–	–	–	–
23	22	21	20	19	18	17	16
–	–	–	–	–	–	–	–
15	14	13	12	11	10	9	8
–	–	–	–	–	–	–	–
7	6	5	4	3	2	1	0
–	–	–	–	–	–	SCO	CE

- **CE: Comparison Edge**

0 = No edge occurred (defined by EDGETYP) on analog comparator output since the last read of ACC_ISR register.

1 = A selected edge (defined by EDGETYP) on analog comparator output occurred since the last read of ACC_ISR register.

- **SCO: Synchronized Comparator Output**

Returns an image of Analog Comparator Output after being pre-processed (refer to [Figure 39-1 on page 1018](#)).

If INV = 0

SCO = 0 if inn > inp

SCO = 1 if inp > inn

If INV = 1

SCO = 1 if inn > inp

SCO = 0 if inp > inn

- **MASK:**

0 = The CE flag is valid.

1 = The CE flag and SCO value are invalid.



39.7.7 ACC Analog Control Register

Name: ACC_ACR
Address: 0x40040094
Access: Read-write

31	30	29	28	27	26	25	24
–	–	–	–	–	–	–	–
23	22	21	20	19	18	17	16
–	–	–	–	–	–	–	–
15	14	13	12	11	10	9	8
–	–	–	–	–	–	–	–
7	6	5	4	3	2	1	0
–	–	–	–	–	HYST		ISEL

This register can only be written if the WPEN bit is cleared in [ACC Write Protect Mode Register](#).

- **ISEL: Current SElection**

Refer to the product Electrical Characteristics.

0 (LOPW) = Low power option.

1 (HISP) = High speed option.

- **HYST: HYSTeresis selection**

0 to 3: Refer to the product Electrical Characteristics.

39.7.8 ACC Write Protect Mode Register

Name: ACC_WPMR

Address: 0x400400E4

Access: Read-write

31	30	29	28	27	26	25	24
WPKEY							
23	22	21	20	19	18	17	16
WPKEY							
15	14	13	12	11	10	9	8
WPKEY							
7	6	5	4	3	2	1	0
-	-	-	-	-	-	-	WPEN

- **WPEN: Write Protect Enable**

0 = Disables the Write Protect if WPKEY corresponds to 0x414343 (“ACC” in ASCII).

1 = Enables the Write Protect if WPKEY corresponds to 0x414343 (“ACC” in ASCII).

Protects the registers:

- [“ACC Mode Register” on page 1024](#)
- [“ACC Analog Control Register” on page 1030](#)

- **WPKEY: Write Protect KEY**

This security code is needed to set/reset the WPROT bit value (see [Section 39.6.3 “Write Protection System”](#) for details).

Must be filled with “ACC” ASCII code.



39.7.9 ACC Write Protect Status Register

Name: ACC_WPSR

Address: 0x400400E8

Access: Read-only

31	30	29	28	27	26	25	24
–	–	–	–	–	–	–	–
23	22	21	20	19	18	17	16
–	–	–	–	–	–	–	–
15	14	13	12	11	10	9	8
–	–	–	–	–	–	–	–
7	6	5	4	3	2	1	0
–	–	–	–	–	–	–	WPROTERR

- **WPROTERR: Write PROTECTION ERROR**

0 = No Write Protect Violation has occurred since the last read of the ACC_WPSR register.

1 = A Write Protect Violation (WPEN = 1) has occurred since the last read of the ACC_WPSR register.

40. Analog-to-Digital Converter (ADC)

40.1 Description

The Analog-to-Digital Converter (ADC) is based on a 12-bit Analog-to-Digital Converter (ADC) managed by an ADC Controller. Refer to the Block Diagram: [Figure 40-1](#). It also integrates a 16-to-1 analog multiplexer, making possible the analog-to-digital conversions of 16 analog lines. The conversions extend from 0V to ADVREF. The ADC supports an 10-bit or 12-bit resolution mode, and conversion results are reported in a common register for all channels, as well as in a channel-dedicated register.

Software trigger, external trigger on rising edge of the ADTRG pin or internal triggers from Timer Counter output(s) are configurable.

The comparison circuitry allows automatic detection of values below a threshold, higher than a threshold, in a given range or outside the range, thresholds and ranges being fully configurable.

The ADC Controller internal fault output is directly connected to PWM Fault input. This input can be asserted by means of comparison circuitry in order to immediately put the PWM outputs in a safe state (pure combinational path).

The ADC also integrates a Sleep Mode and a conversion sequencer and connects with a PDC channel. These features reduce both power consumption and processor intervention.

This ADC has a selectable single-ended or fully differential input and benefits from a 2-bit programmable gain. A whole set of reference voltages is generated internally from a single external reference voltage node that may be equal to the analog supply voltage. An external decoupling capacitance is required for noise filtering.

A digital error correction circuit based on the multi-bit redundant signed digit (RSD) algorithm is employed in order to reduce INL and DNL errors.

Finally, the user can configure ADC timings, such as Startup Time and Tracking Time.

40.2 Embedded Characteristics

- Up to 16 Channels, 12-bit ADC
- 10/12-bit resolution
- Up to 1 MSample/s
- Programmable conversion sequence conversion on each channel
- Integrated temperature sensor
- Automatic calibration mode
- Single ended/differential conversion
- Hardware or Software Trigger
 - External Trigger Pin
 - TimerPWM Event Line
 - Counter Outputs (Corresponding TIOA Trigger)
- Drive of PWM Fault Input
- Programmable gain: 1, 2, 4

40.3 Block Diagram

Figure 40-1. Analog-to-Digital Converter Block Diagram

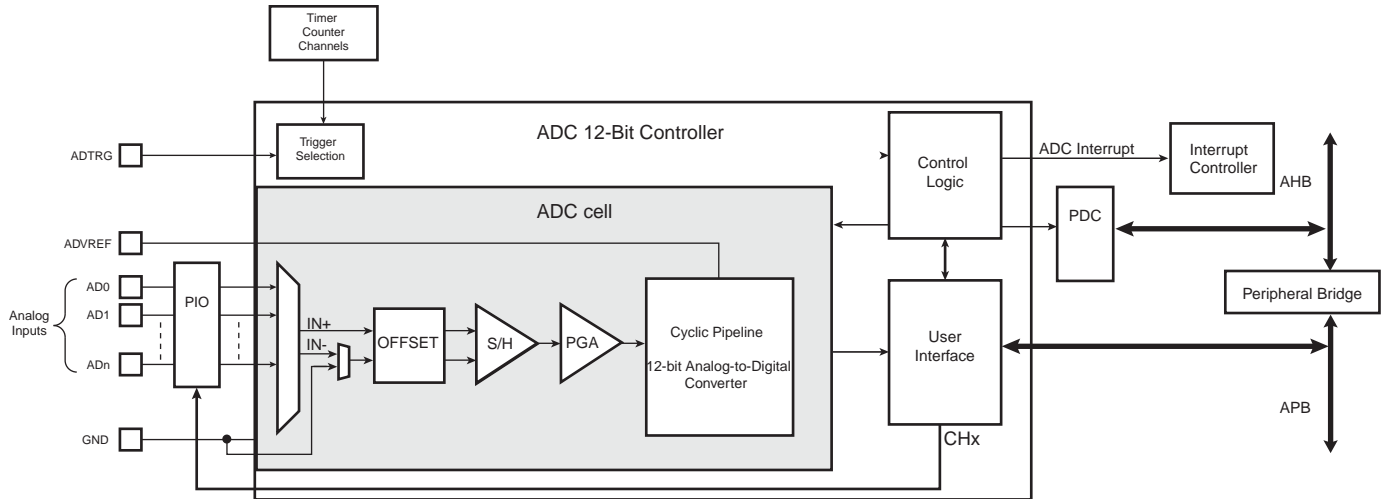

40.4 Signal Description

Table 40-1. ADC Pin Description

Pin Name	Description
ADVREF	Reference voltage
AD0 - AD15 ⁽¹⁾	Analog input channels
ADTRG	External trigger

Note: 1. AD15 is not an actual pin but is connected to a temperature sensor.

40.5 Product Dependencies

40.5.1 Power Management

The ADC Controller is not continuously clocked. The programmer must first enable the ADC Controller MCK in the Power Management Controller (PMC) before using the ADC Controller. However, if the application does not require ADC operations, the ADC Controller clock can be stopped when not needed and restarted when necessary. Configuring the ADC Controller does not require the ADC Controller clock to be enabled.

40.5.2 Interrupt Sources

The ADC interrupt line is connected on one of the internal sources of the Interrupt Controller. Using the ADC interrupt requires the interrupt controller to be programmed first.

Table 40-2. Peripheral IDs

Instance	ID
ADC	29

40.5.3 Analog Inputs

The analog input pins can be multiplexed with PIO lines. In this case, the assignment of the ADC input is automatically done as soon as the corresponding channel is enabled by writing the register ADC_CHER. By default, after reset, the PIO line is configured as input with its pull-up enabled and the ADC input is connected to the GND.

40.5.4 Temperature Sensor

The temperature sensor is internally connected to channel 15 of the ADC.

The temperature sensor provides an output voltage V_T that is proportional to the absolute temperature (PTAT). To activate the temperature sensor, TSON bit (ADC_ACR) needs to be set. After being set, the startup time of the temperature sensor must be achieved prior to initiating any measure.

40.5.5 I/O Lines

The pin ADTRG may be shared with other peripheral functions through the PIO Controller. In this case, the PIO Controller should be set accordingly to assign the pin ADTRG to the ADC function.

Table 40-3. I/O Lines

Instance	Signal	I/O Line	Peripheral
ADC	ADTRG	PA8	B
ADC	AD0	PA17	X1
ADC	AD1	PA18	X1
ADC	AD2/WKUP9	PA19	X1
ADC	AD3/WKUP10	PA20	X1
ADC	AD4/RTCOUT0	PB0	X1
ADC	AD5/RTCOUT1	PB1	X1
ADC	AD6/WKUP12	PB2	X1
ADC	AD7	PB3	X1
ADC	AD8	PA21	X1
ADC	AD9	PA22	X1
ADC	AD10	PC13	X1
ADC	AD11	PC15	X1
ADC	AD12	PC12	X1
ADC	AD13	PC29	X1
ADC	AD14	PC30	X1

40.5.6 Timer Triggers

Timer Counters may or may not be used as hardware triggers depending on user requirements. Thus, some or all of the timer counters may be unconnected.

40.5.7 PWM Event Line

PWM Event Lines may or may not be used as hardware triggers depending on user requirements.

40.5.8 Fault Output

The ADC Controller has the FAULT output connected to the FAULT input of PWM. Please refer to [Section 40.6.13 "Fault Output"](#) and implementation of the PWM in the product.

40.5.9 Conversion Performances

For performance and electrical characteristics of the ADC, see the product DC Characteristics section.

40.6 Functional Description

40.6.1 Analog-to-digital Conversion

The ADC uses the ADC Clock to perform conversions. Converting a single analog value to a 12-bit digital data requires Tracking Clock cycles as defined in the field TRACKTIM of the ["ADC Mode Register"](#) on page 1049 and Transfer Clock cycles as defined in the field TRANSFER of the same register. The ADC Clock frequency is selected in the PRESCAL field of the Mode Register (ADC_MR). The tracking phase starts during the conversion of the previous channel. If the tracking time is longer than the conversion time, the tracking phase is extended to the end of the previous conversion.

The ADC clock range is between $MCK/2$, if PRESCAL is 0, and $MCK/512$, if PRESCAL is set to 255 (0xFF). PRESCAL must be programmed in order to provide an ADC clock frequency according to the parameters given in the product Electrical Characteristics section.

Figure 40-2. Sequence of ADC conversions when Tracking time > Conversion time

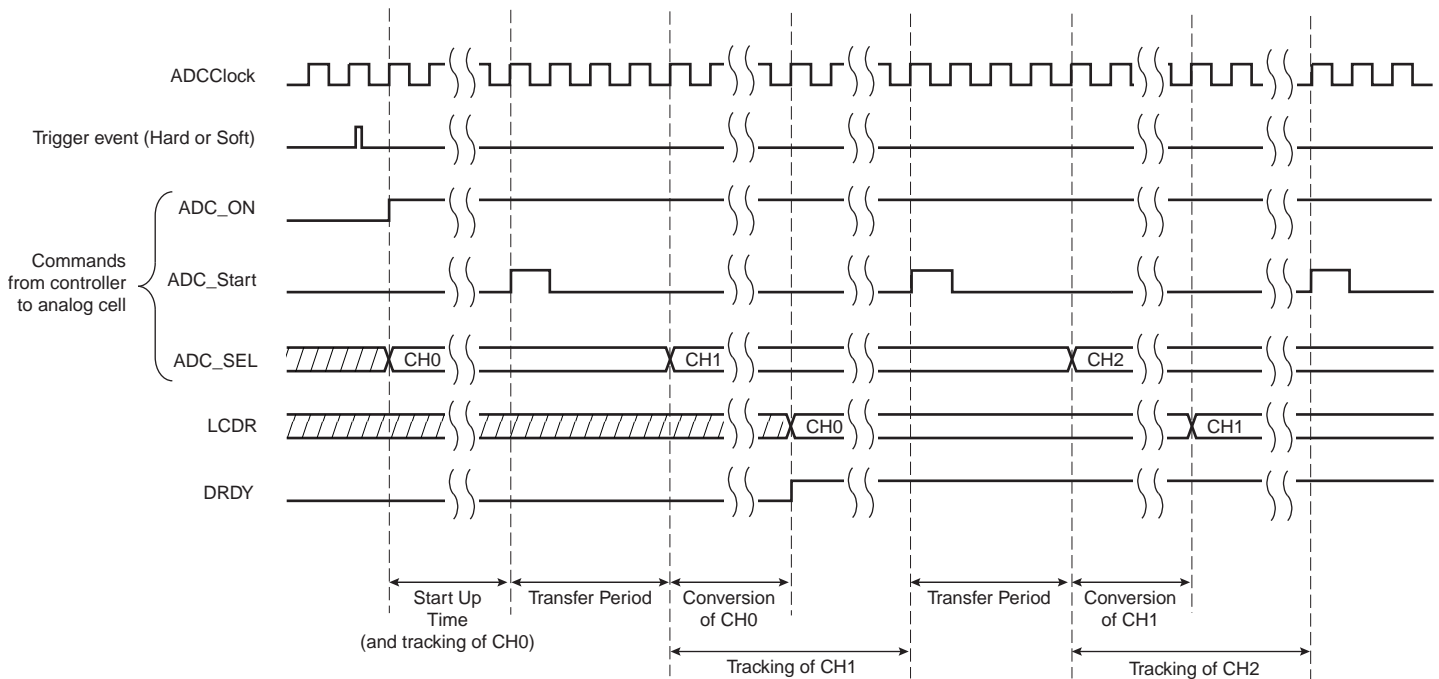
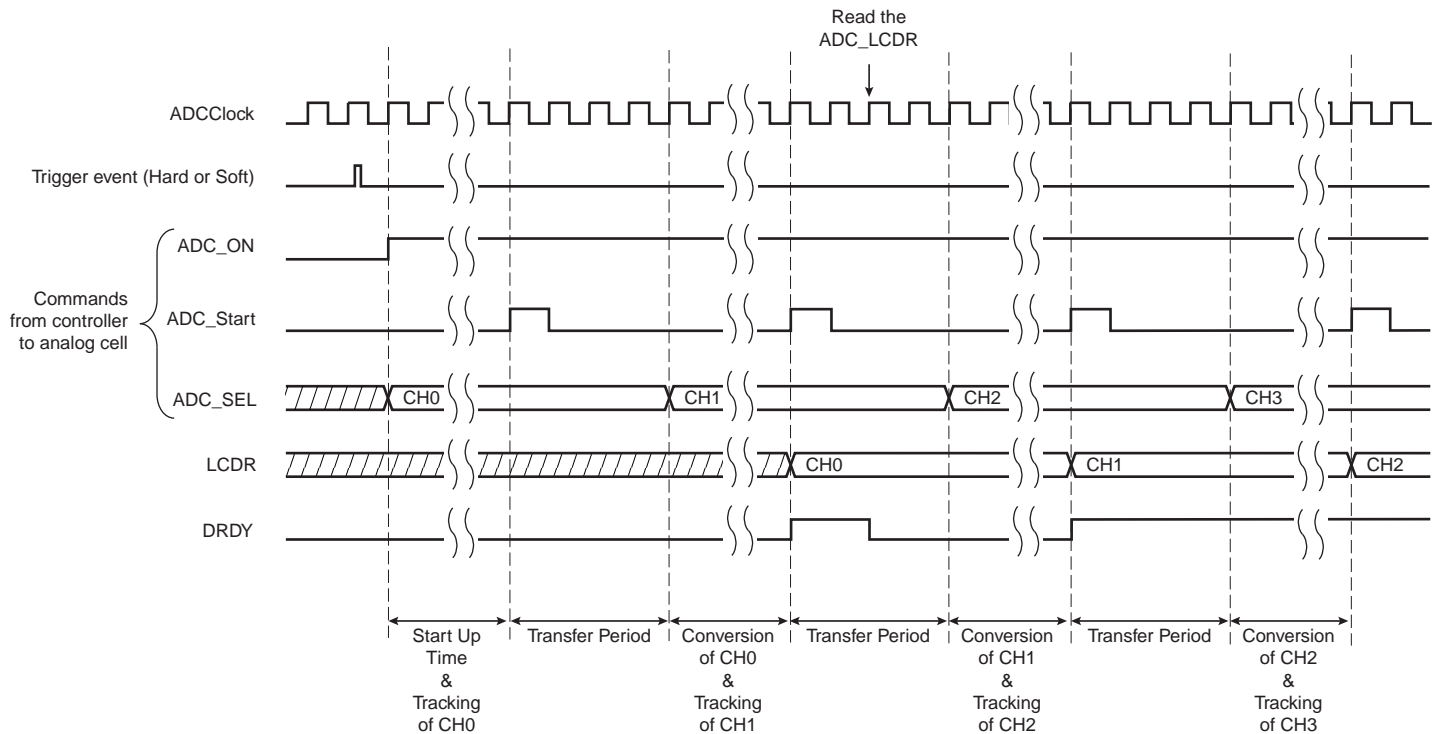

Figure 40-3. Sequence of ADC conversions when Tracking time < Conversion time



40.6.2 Conversion Reference

The conversion is performed on a full range between 0V and the reference voltage pin ADVREF. Analog inputs between these voltages convert to values based on a linear conversion.

40.6.3 Conversion Resolution

The ADC supports 10-bit or 12-bit resolutions. The 10-bit selection is performed by setting the LOWRES bit in the ADC Mode Register (ADC_MR). By default, after a reset, the resolution is the highest and the DATA field in the data registers is fully used. By setting the LOWRES bit, the ADC switches to the lowest resolution and the conversion results can be read in the lowest significant bits of the data registers. The two highest bits of the DATA field in the corresponding ADC_CDR register and of the LDATA field in the ADC_LDCR register read 0.

Moreover, when a PDC channel is connected to the ADC, 12-bit or 10-bit resolution sets the transfer request size to 16 bits.

40.6.4 Conversion Results

When a conversion is completed, the resulting 12-bit digital value is stored in the Channel Data Register (ADC_CDRx) of the current channel and in the ADC Last Converted Data Register (ADC_LDCR). By setting the TAG option in the ADC_EMR, the ADC_LDCR presents the channel number associated to the last converted data in the CHNB field.

The channel EOC bit in the Status Register (ADC_SR) is set and the DRDY is set. In the case of a connected PDC channel, DRDY rising triggers a data transfer request. In any case, either EOC and DRDY can trigger an interrupt.

Reading one of the ADC_CDR registers clears the corresponding EOC bit. Reading ADC_LDCR clears the DRDY bit and EOC bit corresponding to the last converted channel.

Figure 40-4. EOCx and DRDY Flag Behavior

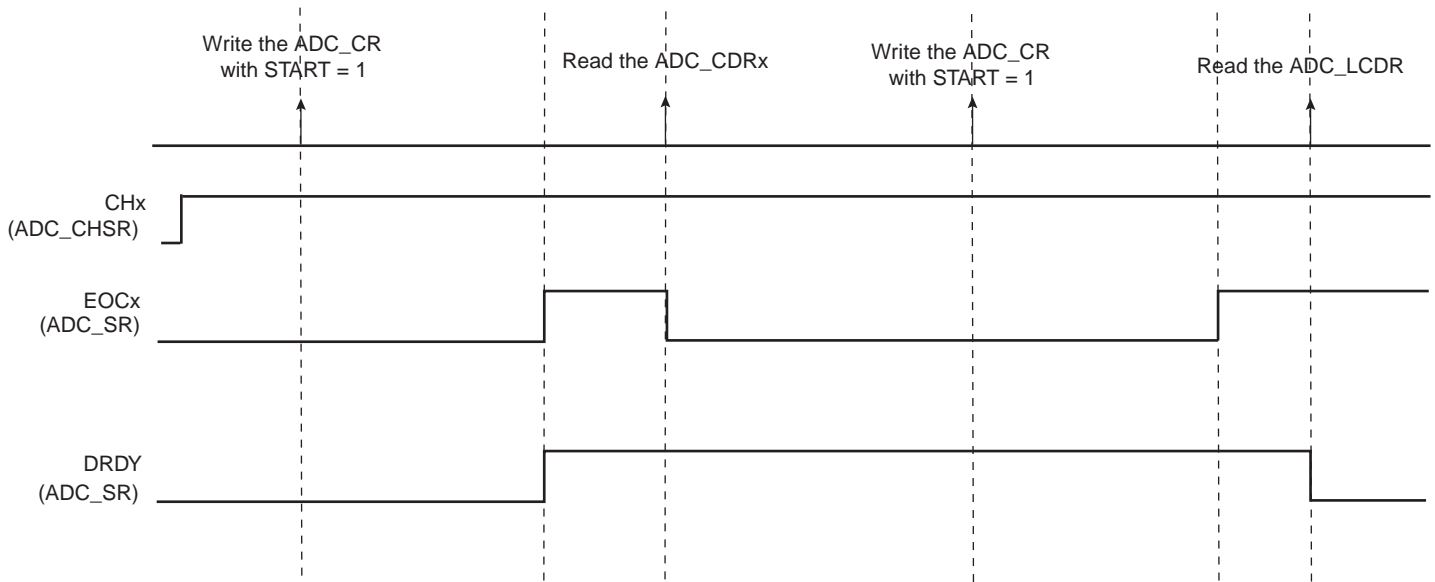

If the ADC_CDR is not read before further incoming data is converted, the corresponding Overrun Error (OVREx) flag is set in the Overrun Status Register (ADC_OVER).

Likewise, new data converted when DRDY is high sets the GOVRE bit (General Overrun Error) in ADC_SR.

The OVREx flag is automatically cleared when ADC_OVER is read, and GOVRE flag is automatically cleared when ADC_SR is read.

Figure 40-5. GOVRE and OVREx Flag Behavior

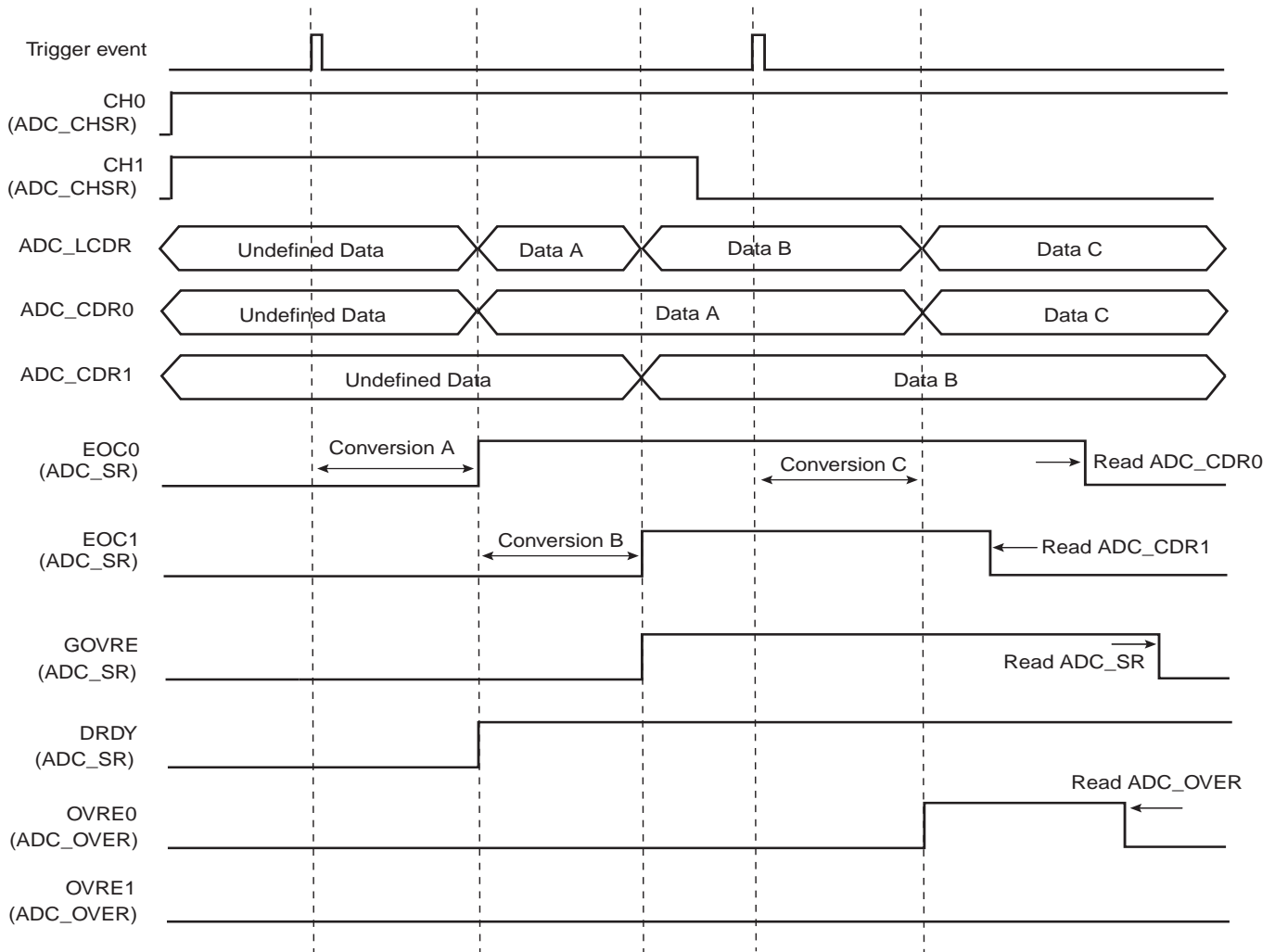

Warning: If the corresponding channel is disabled during a conversion or if it is disabled and then re-enabled during a conversion, its associated data and its corresponding EOC and OVRE flags in ADC_SR are unpredictable.

40.6.5 Conversion Triggers

Conversions of the active analog channels are started with a software or hardware trigger. The software trigger is provided by writing the Control Register (ADC_CR) with the START bit at 1.

The hardware trigger can be one of the TIOA outputs of the Timer Counter channels, PWM Event line, or the external trigger input of the ADC (ADTRG). The hardware trigger is selected with the TRGSEL field in the Mode Register (ADC_MR). The selected hardware trigger is enabled with the TRGEN bit in the “ADC Mode Register”.

The minimum time between 2 consecutive trigger events must be strictly greater than the duration time of the longest conversion sequence according to configuration of registers ADC_MR, ADC_CHSR, ADC_SEQR1, ADC_SEQR2.

If a hardware trigger is selected, the start of a conversion is triggered after a delay starting at each rising edge of the selected signal. Due to asynchronous handling, the delay may vary in a range of 2 MCK clock periods to 1 ADC clock period.

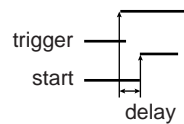

If one of the TIOA outputs is selected, the corresponding Timer Counter channel must be programmed in Waveform Mode.

Only one start command is necessary to initiate a conversion sequence on all the channels. The ADC hardware logic automatically performs the conversions on the active channels, then waits for a new request. The Channel Enable (ADC_CHER) and Channel Disable (ADC_CHDR) Registers permit the analog channels to be enabled or disabled independently.

If the ADC is used with a PDC, only the transfers of converted data from enabled channels are performed and the resulting data buffers should be interpreted accordingly.

40.6.6 Sleep Mode and Conversion Sequencer

The ADC Sleep Mode maximizes power saving by automatically deactivating the ADC when it is not being used for conversions. Sleep Mode is selected by setting the SLEEP bit in the Mode Register ADC_MR.

The Sleep mode is automatically managed by a conversion sequencer, which can automatically process the conversions of all channels at lowest power consumption.

This mode can be used when the minimum period of time between 2 successive trigger events is greater than the startup period of Analog-Digital converter (See the product ADC Characteristics section).

When a start conversion request occurs, the ADC is automatically activated. As the analog cell requires a start-up time, the logic waits during this time and starts the conversion on the enabled channels. When all conversions are complete, the ADC is deactivated until the next trigger. Triggers occurring during the sequence are not taken into account.

A fast wake-up mode is available in the ADC Mode Register (ADC_MR) as a compromise between power saving strategy and responsiveness. Setting the FWUP bit to ‘1’ enables the fast wake-up mode. In fast wake-up mode the ADC cell is not fully deactivated while no conversion is requested, thereby providing less power saving but faster wake-up.

The conversion sequencer allows automatic processing with minimum processor intervention and optimized power consumption. Conversion sequences can be performed periodically using

a Timer/Counter output or the PWM event line. The periodic acquisition of several samples can be processed automatically without any intervention of the processor thanks to the PDC.

The sequence can be customized by programming the Sequence Channel Registers, ADC_SEQR1 and ADC_SEQR2 and setting to 1 the USEQ bit of the Mode Register (ADC_MR). The user can choose a specific order of channels and can program up to 16 conversions by sequence. The user is totally free to create a personal sequence, by writing channel numbers in ADC_SEQR1 and ADC_SEQR2. Not only can channel numbers be written in any sequence, channel numbers can be repeated several times. Only enabled sequence bitfields are converted, consequently to program a 15-conversion sequence, the user can simply put a disable in ADC_CHSR[15], thus disabling the 16THCH field of ADC_SEQR2.

If all ADC channels (i.e. 16) are used on an application board, there is no restriction of usage of the user sequence. But as soon as some ADC channels are not enabled for conversion but rather used as pure digital inputs, the respective indexes of these channels cannot be used in the user sequence fields (ADC_SEQR1, ADC_SEQR2 bitfields). For example, if channel 4 is disabled (ADC_CSR[4] = 0), ADC_SEQR1, ADC_SEQR2 register bitfields USCH1 up to USCH16 must not contain the value 4. Thus the length of the user sequence may be limited by this behavior.

As an example, if only 4 channels over 16 (CH0 up to CH3) are selected for ADC conversions, the user sequence length cannot exceed 4 channels. Each trigger event may launch up to 4 successive conversions of any combination of channels 0 up to 3 but no more (i.e. in this case the sequence CH0, CH0, CH1, CH1 is impossible).

A sequence that repeats several times the same channel requires more enabled channels than channels actually used for conversion. For example, a sequence like CH0, CH0, CH1, CH1 requires 4 enabled channels (4 free channels on application boards) whereas only CH0, CH1 are really converted.

Note: The reference voltage pins always remain connected in normal mode as in sleep mode.

40.6.7 Comparison Window

The ADC Controller features automatic comparison functions. It compares converted values to a low threshold or a high threshold or both, according to the CMPMODE function chosen in the Extended Mode Register (ADC_EMR). The comparison can be done on all channels or only on the channel specified in CMPSEL field of ADC_EMR. To compare all channels the CMP_ALL parameter of ADC_EMR should be set.

The flag can be read on the COMPE bit of the Interrupt Status Register (ADC_ISR) and can trigger an interrupt.

The High Threshold and the Low Threshold can be read/write in the Comparison Window Register (ADC_CWR).

If the comparison window is to be used with LOWRES bit in ADC_MR set to 1, the thresholds do not need to be adjusted as adjustment will be done internally. Whether or not the LOWRES bit is set, thresholds must always be configured in consideration of the maximum ADC resolution.

40.6.8 Differential Inputs

The ADC can be used either as a single ended ADC (DIFF bit equal to 0) or as a fully differential ADC (DIFF bit equal to 1) as shown in [Figure 40-6](#). By default, after a reset, the ADC is in single ended mode.

If ANACH is set in ADC_MR the ADC can apply a different mode on each channel. Otherwise the parameters of CH0 are applied to all channels.

The same inputs are used in single ended or differential mode.

In single ended mode, inputs are managed by a 16:1 channels analog multiplexer. In the fully differential mode, inputs are managed by an 8:1 channels analog multiplexer. See [Table 40-4](#) and [Table 40-5](#).

Table 40-4. Input Pins and Channel Number in Single Ended Mode

Input Pins	Channel Number
AD0	CH0
AD1	CH1
AD2	CH2
AD3	CH3
AD4	CH4
AD5	CH5
AD6	CH6
AD7	CH7
AD8	CH8
AD9	CH9
AD10	CH10
AD11	CH11
AD12	CH12
AD13	CH13
AD14	CH14
AD15	CH15

Table 40-5. Input Pins and Channel Number In Differential Mode

Input Pins	Channel Number
AD0-AD1	CH0
AD2-AD3	CH2
AD4-AD5	CH4
AD6-AD7	CH6
AD8-AD9	CH8
AD10-AD11	CH10
AD12-AD13	CH12
AD14-AD15	CH14

40.6.9 Input Gain and Offset

The ADC has a built in Programmable Gain Amplifier (PGA) and Programmable Offset.

The Programmable Gain Amplifier can be set to gains of 1/2, 1, 2 and 4. The Programmable Gain Amplifier can be used either for single ended applications or for fully differential applications.

If ANACH is set in ADC_MR the ADC can apply different gain and offset on each channel. Otherwise the parameters of CH0 are applied to all channels.

The gain is configurable through the GAIN bit of the Channel Gain Register (ADC_CGR) as shown in [Table 40-6](#).

Table 40-6. Gain of the Sample and Hold Unit: GAIN Bits and DIFF Bit.

GAIN<0:1>	GAIN (DIFF = 0)	GAIN (DIFF = 1)
00	1	0.5
01	1	1
10	2	2
11	4	2

To allow full range, analog offset of the ADC can be configured by the OFFSET bit of the Channel Offset Register (ADC_COR). The Offset is only available in Single Ended Mode.

Table 40-7. Offset of the Sample and Hold Unit: OFFSET DIFF and Gain (G)

OFFSET Bit	OFFSET (DIFF = 0)	OFFSET (DIFF = 1)
0	0	0
1	$(G-1)V_{refin}/2$	

Figure 40-6. Analog Full Scale Ranges in Single Ended/Differential Applications Versus Gain and Offset

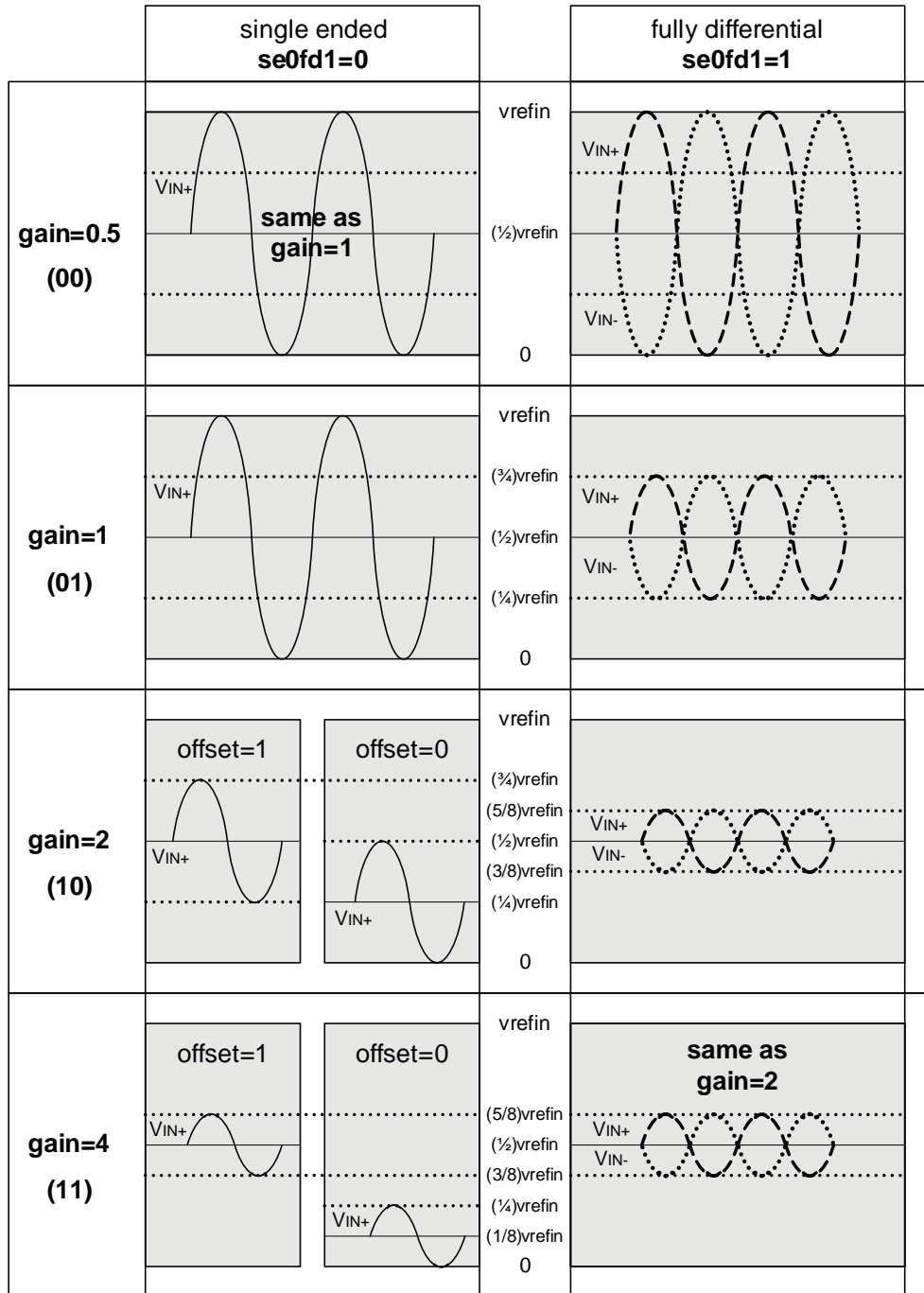

40.6.10 ADC Timings

Each ADC has its own minimal Startup Time that is programmed through the field STARTUP in the Mode Register, ADC_MR.

A minimal Tracking Time is necessary for the ADC to guarantee the best converted final value between two channel selections. This time has to be programmed through the TRACKTIM bit field in the Mode Register, ADC_MR.

When the gain, offset or differential input parameters of the analog cell change between two channels, the analog cell may need a specific settling time before starting the tracking phase. In that case, the controller automatically waits during the settling time defined in the “ADC Mode Register”. Obviously, if the ANACH option is not set, this time is unused.

Warning: No input buffer amplifier to isolate the source is included in the ADC. This must be taken into consideration to program a precise value in the TRACKTIM field. See the product ADC Characteristics section.

40.6.11 Automatic Calibration

The ADC features an automatic calibration (AUTOCALIB) mode for gain errors (calibration).

The automatic calibration sequence can be started at any time writing to '1' the AUTOCAL bit of the ADC Control Register. The automatic calibration sequence requires a software reset command (SWRST in the ADC_CR register) prior to write AUTOCAL bit. The end of calibration sequence is given by the EOCAL bit in the interrupt status register (ADC_ISR), and an interrupt is generated if EOCAL interrupt has been enabled (ADC_IER register).

The calibration sequence will perform an automatic calibration on all enabled channels. The channels required for conversion do not need to be all enabled during the calibration process if they are programmed with the same gain. Only channels with different gain settings need to be enabled. The gain settings of all enabled channels must be set before starting the AUTOCALIB sequence. If the gain settings (ADC_CGR and ADC_COR registers) for a given channel are changed, the AUTOCALIB sequence must then be started again.

The calibration data (on one or more enabled channels) is stored in the internal ADC memory.

Then, when a new conversion is started (on one or more enabled channels), the converted value (in ADC_LCDR or ADC_CDRx registers) is a calibrated value.

Autocalibration is for settings, not for channels. Therefore, if a specific combination of gain has been already calibrated, and a new channel with the same settings is enabled after the initial calibration, there is no need to restart a calibration. If different enabled channels have different gain settings, the corresponding channels must be enabled before starting the calibration.

If a software reset is performed (SWRST bit in ADC_CR) or after power up (or wake-up from Backup mode), the calibration data in the ADC memory is lost.

Changing the ADC running mode (in ADC_CR register) does not affect the calibration data.

Changing the ADC reference voltage (ADVREF pin) requires a new calibration sequence.

For calibration time, gain error after calibration, refer to the 12-bit ADC electrical characteristics section of the product.

40.6.12 Buffer Structure

The PDC read channel is triggered each time a new data is stored in ADC_LCDR register. The same structure of data is repeatedly stored in ADC_LCDR register each time a trigger event occurs. Depending on user mode of operation (ADC_MR, ADC_CHSR, ADC_SEQR1, ADC_SEQR2) the structure differs. Each data transferred to PDC buffer, carried on a half-word (16-bit), consists of last converted data right aligned and when TAG is set in ADC_EMR register, the 4 most significant bits are carrying the channel number thus allowing an easier post-processing in the PDC buffer or better checking the PDC buffer integrity.

40.6.13 Fault Output

The ADC Controller internal fault output is directly connected to PWM fault input. Fault output may be asserted according to the configuration of ADC_EMR (Extended Mode Register) and ADC_CWR (Compare Window Register) and converted values. When the Compare occurs, the ADC fault output generates a pulse of one Master Clock Cycle to the PWM fault input. This fault line can be enabled or disabled within PWM. Should it be activated and asserted by the ADC Controller, the PWM outputs are immediately placed in a safe state (pure combinational path). Note that the ADC fault output connected to the PWM is not the COMPE bit. Thus the Fault Mode (FMODE) within the PWM configuration must be FMODE = 1.

40.6.14 Write Protected Registers

To prevent any single software error that may corrupt ADC behavior, certain address spaces can be write-protected by setting the WPEN bit in the [“ADC Write Protect Mode Register”](#) (ADC_WPMR).

If a write access to the protected registers is detected, then the WPVS flag in the ADC Write Protect Status Register (ADC_WPSR) is set and the field WPVSR indicates in which register the write access has been attempted.

The WPVS flag is automatically reset by reading the ADC Write Protect Status Register (ADC_WPSR).

The protected registers are:

- [“ADC Mode Register” on page 1049](#)
- [“ADC Channel Sequence 1 Register” on page 1052](#)
- [“ADC Channel Sequence 2 Register” on page 1053](#)
- [“ADC Channel Enable Register” on page 1054](#)
- [“ADC Channel Disable Register” on page 1055](#)
- [“ADC Extended Mode Register” on page 1063](#)
- [“ADC Compare Window Register” on page 1064](#)
- [“ADC Channel Gain Register” on page 1065](#)
- [“ADC Channel Offset Register” on page 1066](#)

40.7 Analog-to-Digital Converter (ADC) User Interface

Any offset not listed in [Table 40-8](#) must be considered as “reserved”.

Table 40-8. Register Mapping

Offset	Register	Name	Access	Reset
0x00	Control Register	ADC_CR	Write-only	–
0x04	Mode Register	ADC_MR	Read-write	0x00000000
0x08	Channel Sequence Register 1	ADC_SEQR1	Read-write	0x00000000
0x0C	Channel Sequence Register 2	ADC_SEQR2	Read-write	0x00000000
0x10	Channel Enable Register	ADC_CHER	Write-only	–
0x14	Channel Disable Register	ADC_CHDR	Write-only	–
0x18	Channel Status Register	ADC_CHSR	Read-only	0x00000000
0x1C	Reserved	–	–	–
0x20	Last Converted Data Register	ADC_LCDR	Read-only	0x00000000
0x24	Interrupt Enable Register	ADC_IER	Write-only	–
0x28	Interrupt Disable Register	ADC_IDR	Write-only	–
0x2C	Interrupt Mask Register	ADC_IMR	Read-only	0x00000000
0x30	Interrupt Status Register	ADC_ISR	Read-only	0x00000000
0x3C	Overrun Status Register	ADC_OVER	Read-only	0x00000000
0x40	Extended Mode Register	ADC_EMR	Read-write	0x00000000
0x44	Compare Window Register	ADC_CWR	Read-write	0x00000000
0x48	Channel Gain Register	ADC_CGR	Read-write	0x00000000
0x4C	Channel Offset Register	ADC_COR	Read-write	0x00000000
0x50	Channel Data Register 0	ADC_CDR0	Read-only	0x00000000
0x54	Channel Data Register 1	ADC_CDR1	Read-only	0x00000000
...
0x8C	Channel Data Register 15	ADC_CDR15	Read-only	0x00000000
0x90 - 0x90	Reserved	–	–	–
0x94	Analog Control Register	ADC_ACR	Read-write	0x00000100
0x98 - 0xAC	Reserved	–	–	–
0xC4 - 0xE0	Reserved	–	–	–
0xE4	Write Protect Mode Register	ADC_WPMR	Read-write	0x00000000
0xE8	Write Protect Status Register	ADC_WPSR	Read-only	0x00000000
0xEC - 0xF8	Reserved	–	–	–
0xFC	Reserved	–	–	–
0x100 - 0x124	Reserved for PDC Registers	–	–	–

Note: If an offset is not listed in the table it must be considered as “reserved”.

40.7.1 ADC Control Register

Name: ADC_CR
Address: 0x40038000
Access: Write-only

31	30	29	28	27	26	25	24
–	–	–	–	–	–	–	–
23	22	21	20	19	18	17	16
–	–	–	–	–	–	–	–
15	14	13	12	11	10	9	8
–	–	–	–	–	–	–	–
7	6	5	4	3	2	1	0
–	–	–	–	AUTOCAL	–	START	SWRST

- **SWRST: Software Reset**

0 = No effect.

1 = Resets the ADC simulating a hardware reset.

- **START: Start Conversion**

0 = No effect.

1 = Begins analog-to-digital conversion.

- **AUTOCAL: Automatic Calibration of ADC**

0 = No effect.

1 = Launch an automatic calibration of the ADC cell on next sequence.

40.7.2 ADC Mode Register

Name: ADC_MR
Address: 0x40038004
Access: Read-write

31	30	29	28	27	26	25	24
USEQ	–	TRANSFER		TRACKTIM			
23	22	21	20	19	18	17	16
ANACH	–	SETTLING		STARTUP			
15	14	13	12	11	10	9	8
PRESCAL							
7	6	5	4	3	2	1	0
FREERUN	FWUP	SLEEP	LOWRES	TRGSEL		TRGEN	

This register can only be written if the WPEN bit is cleared in “ADC Write Protect Mode Register” on page 1069.

- **TRGEN: Trigger Enable**

Value	Name	Description
0	DIS	Hardware triggers are disabled. Starting a conversion is only possible by software.
1	EN	Hardware trigger selected by TRGSEL field is enabled.

- **TRGSEL: Trigger Selection**

Value	Name	Description
0	ADC_TRIG0	External trigger
1	ADC_TRIG1	TIO Output of the Timer Counter Channel 0
2	ADC_TRIG2	TIO Output of the Timer Counter Channel 1
3	ADC_TRIG3	TIO Output of the Timer Counter Channel 2
4	ADC_TRIG4	PWM Event Line 0
5	ADC_TRIG5	PWM Event Line 1
6	ADC_TRIG6	Reserved
7	–	Reserved

- **LOWRES: Resolution**

Value	Name	Description
0	BITS_12	12-bit resolution
1	BITS_10	10-bit resolution

- **SLEEP: Sleep Mode**

Value	Name	Description
0	NORMAL	Normal Mode: The ADC Core and reference voltage circuitry are kept ON between conversions
1	SLEEP	Sleep Mode: The ADC Core and reference voltage circuitry are OFF between conversions

- **FWUP: Fast Wake Up**

Value	Name	Description
0	OFF	Normal Sleep Mode: The sleep mode is defined by the SLEEP bit
1	ON	Fast Wake Up Sleep Mode: The Voltage reference is ON between conversions and ADC Core is OFF

- **FREERUN: Free Run Mode**

Value	Name	Description
0	OFF	Normal Mode
1	ON	Free Run Mode: Never wait for any trigger.

- **PRESCAL: Prescaler Rate Selection**

$$\text{ADCClock} = \text{MCK} / ((\text{PRESCAL} + 1) * 2)$$

- **STARTUP: Start Up Time**

Value	Name	Description
0	SUT0	0 periods of ADCClock
1	SUT8	8 periods of ADCClock
2	SUT16	16 periods of ADCClock
3	SUT24	24 periods of ADCClock
4	SUT64	64 periods of ADCClock
5	SUT80	80 periods of ADCClock
6	SUT96	96 periods of ADCClock
7	SUT112	112 periods of ADCClock
8	SUT512	512 periods of ADCClock
9	SUT576	576 periods of ADCClock
10	SUT640	640 periods of ADCClock
11	SUT704	704 periods of ADCClock
12	SUT768	768 periods of ADCClock
13	SUT832	832 periods of ADCClock
14	SUT896	896 periods of ADCClock
15	SUT960	960 periods of ADCClock

- **SETTLING: Analog Settling Time**

Value	Name	Description
0	AST3	3 periods of ADCClock
1	AST5	5 periods of ADCClock
2	AST9	9 periods of ADCClock
3	AST17	17 periods of ADCClock

- **ANACH: Analog Change**

Value	Name	Description
0	NONE	No analog change on channel switching: DIFF0, GAIN0 and OFF0 are used for all channels
1	ALLOWED	Allows different analog settings for each channel. See ADC_CGR and ADC_COR Registers

- **TRACKTIM: Tracking Time**

Tracking Time = (TRACKTIM + 1) * ADCClock periods.

- **TRANSFER: Transfer Period**

Transfer Period = (TRANSFER * 2 + 3) ADCClock periods.

- **USEQ: Use Sequence Enable**

Value	Name	Description
0	NUM_ORDER	Normal Mode: The controller converts channels in a simple numeric order depending only on the channel index.
1	REG_ORDER	User Sequence Mode: The sequence respects what is defined in ADC_SEQR1 and ADC_SEQR2 registers and can be used to convert several times the same channel.



40.7.3 ADC Channel Sequence 1 Register

Name: ADC_SEQR1

Address: 0x40038008

Access: Read-write

31	30	29	28	27	26	25	24
–	USCH8				–	USCH7	
23	22	21	20	19	18	17	16
–	USCH6				–	USCH5	
15	14	13	12	11	10	9	8
–	USCH4				–	USCH3	
7	6	5	4	3	2	1	0
–	USCH2				–	USCH1	

This register can only be written if the WPEN bit is cleared in [“ADC Write Protect Mode Register” on page 1069](#).

• **USCHx: User Sequence Number x**

The sequence number x (USCHx) can be programmed by the Channel number CHy where y is the value written in this field. The allowed range is 0 up to 7. So it is only possible to use the sequencer from CH0 to CH7.

This register activates only if ADC_MR(USEQ) field is set to ‘1’.

Any USCHx field is taken into account only if ADC_CHSR(CHx) register field reads logical ‘1’ else any value written in USCHx does not add the corresponding channel in the conversion sequence.

When configuring consecutive fields with the same value, the associated channel is sampled as many time as the number of consecutive values, this part of the conversion sequence being triggered by a unique event.

Configuring the same value in different fields leads to multiple samples of the same channel during the conversion sequence. This can be done consecutively, or not, according to user needs.

40.7.4 ADC Channel Sequence 2 Register

Name: ADC_SEQR2

Address: 0x4003800C

Access: Read-write

31	30	29	28	27	26	25	24
–	USCH16			–	USCH15		
23	22	21	20	19	18	17	16
–	USCH14			–	USCH13		
15	14	13	12	11	10	9	8
–	USCH12			–	USCH11		
7	6	5	4	3	2	1	0
–	USCH10			–	USCH9		

This register can only be written if the WPEN bit is cleared in [“ADC Write Protect Mode Register” on page 1069](#).

- **USCHx: User Sequence Number x**

The sequence number x (USCHx) can be programmed by the Channel number CHy where y is the value written in this field. The allowed range is 0 up to 7. So it is only possible to use the sequencer from CH0 to CH7.

This register activates only if ADC_MR(USEQ) field is set to ‘1’.

Any USCHx field is taken into account only if ADC_CHSR(CHx) register field reads logical ‘1’ else any value written in USCHx does not add the corresponding channel in the conversion sequence.

When configuring consecutive fields with the same value, the associated channel is sampled as many time as the number of consecutive values, this part of the conversion sequence being triggered by a unique event.

Configuring the same value in different fields leads to multiple samples of the same channel during the conversion sequence. This can be done consecutively, or not, according to user needs.

40.7.5 ADC Channel Enable Register

Name: ADC_CHER

Address: 0x40038010

Access: Write-only

31	30	29	28	27	26	25	24
–	–	–	–	–	–	–	–
23	22	21	20	19	18	17	16
–	–	–	–	–	–	–	–
15	14	13	12	11	10	9	8
CH15	CH14	CH13	CH12	CH11	CH10	CH9	CH8
7	6	5	4	3	2	1	0
CH7	CH6	CH5	CH4	CH3	CH2	CH1	CH0

This register can only be written if the WPEN bit is cleared in [“ADC Write Protect Mode Register” on page 1069](#).

- **CHx: Channel x Enable**

0 = No effect.

1 = Enables the corresponding channel.

Note: if USEQ = 1 in ADC_MR register, CHx corresponds to the xth channel of the sequence described in ADC_SEQR1 and ADC_SEQR2.

40.7.6 ADC Channel Disable Register

Name: ADC_CHDR

Address: 0x40038014

Access: Write-only

31	30	29	28	27	26	25	24
–	–	–	–	–	–	–	–
23	22	21	20	19	18	17	16
–	–	–	–	–	–	–	–
15	14	13	12	11	10	9	8
CH15	CH14	CH13	CH12	CH11	CH10	CH9	CH8
7	6	5	4	3	2	1	0
CH7	CH6	CH5	CH4	CH3	CH2	CH1	CH0

This register can only be written if the WPEN bit is cleared in [“ADC Write Protect Mode Register” on page 1069](#).

- **CHx: Channel x Disable**

0 = No effect.

1 = Disables the corresponding channel.

Warning: If the corresponding channel is disabled during a conversion or if it is disabled then reenabled during a conversion, its associated data and its corresponding EOC and OVRE flags in ADC_SR are unpredictable.



40.7.7 ADC Channel Status Register

Name: ADC_CHSR

Address: 0x40038018

Access: Read-only

31	30	29	28	27	26	25	24
–	–	–	–	–	–	–	–
23	22	21	20	19	18	17	16
–	–	–	–	–	–	–	–
15	14	13	12	11	10	9	8
CH15	CH14	CH13	CH12	CH11	CH10	CH9	CH8
7	6	5	4	3	2	1	0
CH7	CH6	CH5	CH4	CH3	CH2	CH1	CH0

- **CHx: Channel x Status**

0 = Corresponding channel is disabled.

1 = Corresponding channel is enabled.

40.7.8 ADC Last Converted Data Register

Name: ADC_LCDR

Address: 0x40038020

Access: Read-only

31	30	29	28	27	26	25	24
–	–	–	–	–	–	–	–
23	22	21	20	19	18	17	16
–	–	–	–	–	–	–	–
15	14	13	12	11	10	9	8
CHNB				LDATA			
7	6	5	4	3	2	1	0
LDATA							

- **LDATA: Last Data Converted**

The analog-to-digital conversion data is placed into this register at the end of a conversion and remains until a new conversion is completed.

- **CHNB: Channel Number**

Indicates the last converted channel when the TAG option is set to 1 in the ADC_EMR register. If the TAG option is not set, CHNB = 0.



40.7.9 ADC Interrupt Enable Register

Name: ADC_IER

Address: 0x40038024

Access: Write-only

31	30	29	28	27	26	25	24
–	–	–	RXBUFF	ENDRX	COMPE	GOVRE	DRDY
23	22	21	20	19	18	17	16
EOCAL	–	–	–	–	–	–	–
15	14	13	12	11	10	9	8
EOC15	EOC14	EOC13	EOC12	EOC11	EOC10	EOC9	EOC8
7	6	5	4	3	2	1	0
EOC7	EOC6	EOC5	EOC4	EOC3	EOC2	EOC1	EOC0

- **EOCx:** End of Conversion Interrupt Enable x
- **EOCAL:** End of Calibration Sequence
- **DRDY:** Data Ready Interrupt Enable
- **GOVRE:** General Overrun Error Interrupt Enable
- **COMPE:** Comparison Event Interrupt Enable
- **ENDRX:** End of Receive Buffer Interrupt Enable
- **RXBUFF:** Receive Buffer Full Interrupt Enable

0 = No effect.

1 = Enables the corresponding interrupt.

40.7.10 ADC Interrupt Disable Register

Name: ADC_IDR
Address: 0x40038028
Access: Write-only

31	30	29	28	27	26	25	24
–	–	–	RXBUFF	ENDRX	COMPE	GOVRE	DRDY
23	22	21	20	19	18	17	16
EOCAL	–	–	–	–	–	–	–
15	14	13	12	11	10	9	8
EOC15	EOC14	EOC13	EOC12	EOC11	EOC10	EOC9	EOC8
7	6	5	4	3	2	1	0
EOC7	EOC6	EOC5	EOC4	EOC3	EOC2	EOC1	EOC0

- **EOCx:** End of Conversion Interrupt Disable x
- **EOCAL:** End of Calibration Sequence
- **DRDY:** Data Ready Interrupt Disable
- **GOVRE:** General Overrun Error Interrupt Disable
- **COMPE:** Comparison Event Interrupt Disable
- **ENDRX:** End of Receive Buffer Interrupt Disable
- **RXBUFF:** Receive Buffer Full Interrupt Disable

0 = No effect.

1 = Disables the corresponding interrupt.

40.7.11 ADC Interrupt Mask Register

Name: ADC_IMR

Address: 0x4003802C

Access: Read-only

31	30	29	28	27	26	25	24
–	–	–	RXBUFF	ENDRX	COMPE	GOVRE	DRDY
23	22	21	20	19	18	17	16
EOCAL	–	–	–	–	–	–	–
15	14	13	12	11	10	9	8
EOC15	EOC14	EOC13	EOC12	EOC11	EOC10	EOC9	EOC8
7	6	5	4	3	2	1	0
EOC7	EOC6	EOC5	EOC4	EOC3	EOC2	EOC1	EOC0

- **EOCx:** End of Conversion Interrupt Mask x
- **EOCAL:** End of Calibration Sequence
- **DRDY:** Data Ready Interrupt Mask
- **GOVRE:** General Overrun Error Interrupt Mask
- **COMPE:** Comparison Event Interrupt Mask
- **ENDRX:** End of Receive Buffer Interrupt Mask
- **RXBUFF:** Receive Buffer Full Interrupt Mask

0 = The corresponding interrupt is disabled.

1 = The corresponding interrupt is enabled.

40.7.12 ADC Interrupt Status Register

Name: ADC_ISR
Address: 0x40038030
Access: Read-only

31	30	29	28	27	26	25	24
–	–	–	RXBUFF	ENDRX	COMPE	GOVRE	DRDY
23	22	21	20	19	18	17	16
EOCAL	–	–	–	–	–	–	–
15	14	13	12	11	10	9	8
EOC15	EOC14	EOC13	EOC12	EOC11	EOC10	EOC9	EOC8
7	6	5	4	3	2	1	0
EOC7	EOC6	EOC5	EOC4	EOC3	EOC2	EOC1	EOC0

- **EOCx: End of Conversion x**

0 = Corresponding analog channel is disabled, or the conversion is not finished. This flag is cleared when reading the corresponding ADC_CDRx registers.

1 = Corresponding analog channel is enabled and conversion is complete.

- **EOCAL: End of Calibration Sequence**

0 = Calibration sequence is on going, or no calibration sequence has been requested.

1 = Calibration sequence is complete.

- **DRDY: Data Ready**

0 = No data has been converted since the last read of ADC_LCDR.

1 = At least one data has been converted and is available in ADC_LCDR.

- **GOVRE: General Overrun Error**

0 = No General Overrun Error occurred since the last read of ADC_ISR.

1 = At least one General Overrun Error has occurred since the last read of ADC_ISR.

- **COMPE: Comparison Error**

0 = No Comparison Error since the last read of ADC_ISR.

1 = At least one Comparison Error (defined in the ADC_EMR and ADC_CWR registers) has occurred since the last read of ADC_ISR.

- **ENDRX: End of RX Buffer**

0 = The Receive Counter Register has not reached 0 since the last write in ADC_RCR or ADC_RNCR.

1 = The Receive Counter Register has reached 0 since the last write in ADC_RCR or ADC_RNCR.

- **RXBUFF: RX Buffer Full**

0 = ADC_RCR or ADC_RNCR have a value other than 0.

1 = Both ADC_RCR and ADC_RNCR have a value of 0.

40.7.13 ADC Overrun Status Register

Name: ADC_OVER

Address: 0x4003803C

Access: Read-only

31	30	29	28	27	26	25	24
–	–	–	–	–	–	–	–
23	22	21	20	19	18	17	16
–	–	–	–	–	–	–	–
15	14	13	12	11	10	9	8
OVRE15	OVRE14	OVRE13	OVRE12	OVRE11	OVRE10	OVRE9	OVRE8
7	6	5	4	3	2	1	0
OVRE7	OVRE6	OVRE5	OVRE4	OVRE3	OVRE2	OVRE1	OVRE0

- **OVREx: Overrun Error x**

0 = No overrun error on the corresponding channel since the last read of ADC_OVER.

1 = There has been an overrun error on the corresponding channel since the last read of ADC_OVER.

40.7.14 ADC Extended Mode Register

Name: ADC_EMR
Address: 0x40038040
Access: Read-write

31	30	29	28	27	26	25	24
–	–	–	–	–	–	–	TAG
23	22	21	20	19	18	17	16
–	–	–	–	–	–	–	–
15	14	13	12	11	10	9	8
–	–	–	–	–	–	CMPALL	–
7	6	5	4	3	2	1	0
CMPSEL				–	–	CMPMODE	

This register can only be written if the WPEN bit is cleared in “[ADC Write Protect Mode Register](#)” on page 1069.

- **CMPMODE: Comparison Mode**

Value	Name	Description
0	LOW	Generates an event when the converted data is lower than the low threshold of the window.
1	HIGH	Generates an event when the converted data is higher than the high threshold of the window.
2	IN	Generates an event when the converted data is in the comparison window.
3	OUT	Generates an event when the converted data is out of the comparison window.

- **CMPSEL: Comparison Selected Channel**

If CMPALL = 0: CMPSEL indicates which channel has to be compared.

If CMPALL = 1: No effect.

- **CMPALL: Compare All Channels**

0 = Only channel indicated in CMPSEL field is compared.

1 = All channels are compared.

- **TAG: TAG of the ADC_LDCR register**

0 = Set CHNB to zero in ADC_LDCR.

1 = Append the channel number to the conversion result in ADC_LDCR register.

40.7.15 ADC Compare Window Register

Name: ADC_CWR
Address: 0x40038044
Access: Read-write

31	30	29	28	27	26	25	24
–	–	–	–	HIGHTHRES			
23	22	21	20	19	18	17	16
HIGHTHRES							
15	14	13	12	11	10	9	8
–	–	–	–	LOWTHRES			
7	6	5	4	3	2	1	0
LOWTHRES							

This register can only be written if the WPEN bit is cleared in “[ADC Write Protect Mode Register](#)” on page 1069.

- **LOWTHRES: Low Threshold**

Low threshold associated to compare settings of the ADC_EMR register.

If LOWRES is set in ADC_MR, only the 12 LSB of LOWTHRES must be programmed. The 2 LSB will be automatically discarded to match the value carried on ADC_CDR (10-bit).

- **HIGHTHRES: High Threshold**

High threshold associated to compare settings of the ADC_EMR register.

If LOWRES is set in ADC_MR, only the 12 LSB of HIGHTHRES must be programmed. The 2 LSB will be automatically discarded to match the value carried on ADC_CDR (10-bit).

40.7.16 ADC Channel Gain Register

Name: ADC_CGR
Address: 0x40038048
Access: Read-write

31	30	29	28	27	26	25	24
GAIN15		GAIN14		GAIN13		GAIN12	
23	22	21	20	19	18	17	16
GAIN11		GAIN10		GAIN9		GAIN8	
15	14	13	12	11	10	9	8
GAIN7		GAIN6		GAIN5		GAIN4	
7	6	5	4	3	2	1	0
GAIN3		GAIN2		GAIN1		GAIN0	

This register can only be written if the WPEN bit is cleared in [“ADC Write Protect Mode Register” on page 1069](#).

- **GAINx: Gain for channel x**

Gain applied on input of analog-to-digital converter.

GAINx		Gain applied when DIFFx = 0	Gain applied when DIFFx = 1
0	0	1	0.5
0	1	1	1
1	0	2	2
1	1	4	2

The DIFFx mentioned in this table is described in the following register, ADC_COR.



40.7.17 ADC Channel Offset Register

Name: ADC_COR

Address: 0x4003804C

Access: Read-write

31	30	29	28	27	26	25	24
DIFF15	DIFF14	DIFF13	DIFF12	DIFF11	DIFF10	DIFF9	DIFF8
23	22	21	20	19	18	17	16
DIFF7	DIFF6	DIFF5	DIFF4	DIFF3	DIFF2	DIFF1	DIFF0
15	14	13	12	11	10	9	8
OFF15	OFF14	OFF13	OFF12	OFF11	OFF10	OFF9	OFF8
7	6	5	4	3	2	1	0
OFF7	OFF6	OFF5	OFF4	OFF3	OFF2	OFF1	OFF0

This register can only be written if the WPEN bit is cleared in [“ADC Write Protect Mode Register” on page 1069](#).

- **OFFx: Offset for channel x**

0 = No Offset.

1 = Center the analog signal on $V_{refin}/2$ before the gain scaling. The Offset applied is: $(G-1)V_{refin}/2$

where G is the gain applied (see description of ADC_CGR register).

- **DIFFx: Differential inputs for channel x**

0 = Single Ended Mode.

1 = Fully Differential Mode.

40.7.18 ADC Channel Data Register

Name: ADC_CDRx [x=0..15]

Address: 0x40038050

Access: Read-write

31	30	29	28	27	26	25	24
–	–	–	–	–	–	–	–
23	22	21	20	19	18	17	16
–	–	–	–	–	–	–	–
15	14	13	12	11	10	9	8
–	–	–	–	DATA			
7	6	5	4	3	2	1	0
DATA							

- DATA: Converted Data**

The analog-to-digital conversion data is placed into this register at the end of a conversion and remains until a new conversion is completed. The Convert Data Register (CDR) is only loaded if the corresponding analog channel is enabled.



40.7.19 ADC Analog Control Register

Name: ADC_ACR

Address: 0x40038094

Access: Read-write

31	30	29	28	27	26	25	24
–	–	–	–	–	–	–	–
23	22	21	20	19	18	17	16
–	–	–	–	–	–	–	–
15	14	13	12	11	10	9	8
–	–	–	–	–	–	IBCTL	
7	6	5	4	3	2	1	0
–	–	–	TSON	–	–	–	

This register can only be written if the WPEN bit is cleared in [“ADC Write Protect Mode Register” on page 1069](#).

- **TSON: Temperature Sensor On**

0 = Temperature sensor is off.

1 = Temperature sensor is on.

- **IBCTL: ADC Bias Current Control**

Allows to adapt performance versus power consumption. (See the product electrical characteristics for further details.)

40.7.20 ADC Write Protect Mode Register

Name: ADC_WPMR

Address: 0x400380E4

Access: Read-write

31	30	29	28	27	26	25	24
WPKEY							
23	22	21	20	19	18	17	16
WPKEY							
15	14	13	12	11	10	9	8
WPKEY							
7	6	5	4	3	2	1	0
-	-	-	-	-	-	-	WPEN

- **WPEN: Write Protect Enable**

0 = Disables the Write Protect if WPKEY corresponds to 0x414443 (“ADC” in ASCII).

1 = Enables the Write Protect if WPKEY corresponds to 0x414443 (“ADC” in ASCII).

Protects the registers:

[“ADC Mode Register” on page 1049](#)

[“ADC Channel Sequence 1 Register” on page 1052](#)

[“ADC Channel Sequence 2 Register” on page 1053](#)

[“ADC Channel Enable Register” on page 1054](#)

[“ADC Channel Disable Register” on page 1055](#)

[“ADC Extended Mode Register” on page 1063](#)

[“ADC Compare Window Register” on page 1064](#)

[“ADC Channel Gain Register” on page 1065](#)

[“ADC Channel Offset Register” on page 1066](#)

[“ADC Analog Control Register” on page 1068](#)

- **WPKEY: Write Protect KEY**

Should be written at value 0x414443 (“ADC” in ASCII). Writing any other value in this field aborts the write operation of the WPEN bit. Always reads as 0.

40.7.21 ADC Write Protect Status Register

Name: ADC_WPSR

Address: 0x400380E8

Access: Read-only

31	30	29	28	27	26	25	24
-	-	-	-	-	-	-	-
23	22	21	20	19	18	17	16
WPVSR							
15	14	13	12	11	10	9	8
WPVSR							
7	6	5	4	3	2	1	0
-	-	-	-	-	-	-	WPVS

- **WPVS: Write Protect Violation Status**

0 = No Write Protect Violation has occurred since the last read of the ADC_WPSR register.

1 = A Write Protect Violation has occurred since the last read of the ADC_WPSR register. If this violation is an unauthorized attempt to write a protected register, the associated violation is reported into field WPVSR.

- **WPVSR: Write Protect Violation Source**

When WPVS is active, this field indicates the write-protected register (through address offset or code) in which a write access has been attempted.

Reading ADC_WPSR automatically clears all fields.

41. Digital-to-Analog Converter Controller (DACC)

41.1 Description

The Digital-to-Analog Converter Controller (DACC) offers up to 2 analog outputs, making it possible for the digital-to-analog conversion to drive up to 2 independent analog lines.

The DACC supports 12-bit resolution. Data to be converted are sent in a common register for all channels. External triggers or free running mode are configurable.

The DACC integrates a Sleep Mode and connects with a PDC channel. These features reduce both power consumption and processor intervention.

The user can configure DACC timings, such as Startup Time and Refresh Period.

41.2 Embedded Characteristics

- Up to 2 channel 12-bit DAC
- Up to 2 mega-samples conversion rate in single channel mode
- Flexible conversion range
- Multiple trigger sources for each channel
- 2 Sample/Hold (S/H) outputs
- Built-in offset and gain calibration
- Possibility to drive output to ground
- Possibility to use as input to analog comparator or ADC (as an internal wire and without S/H stage)
- Two PDC channels
- Power reduction mode

41.3 Block Diagram

Figure 41-1. Digital-to-Analog Converter Controller Block Diagram

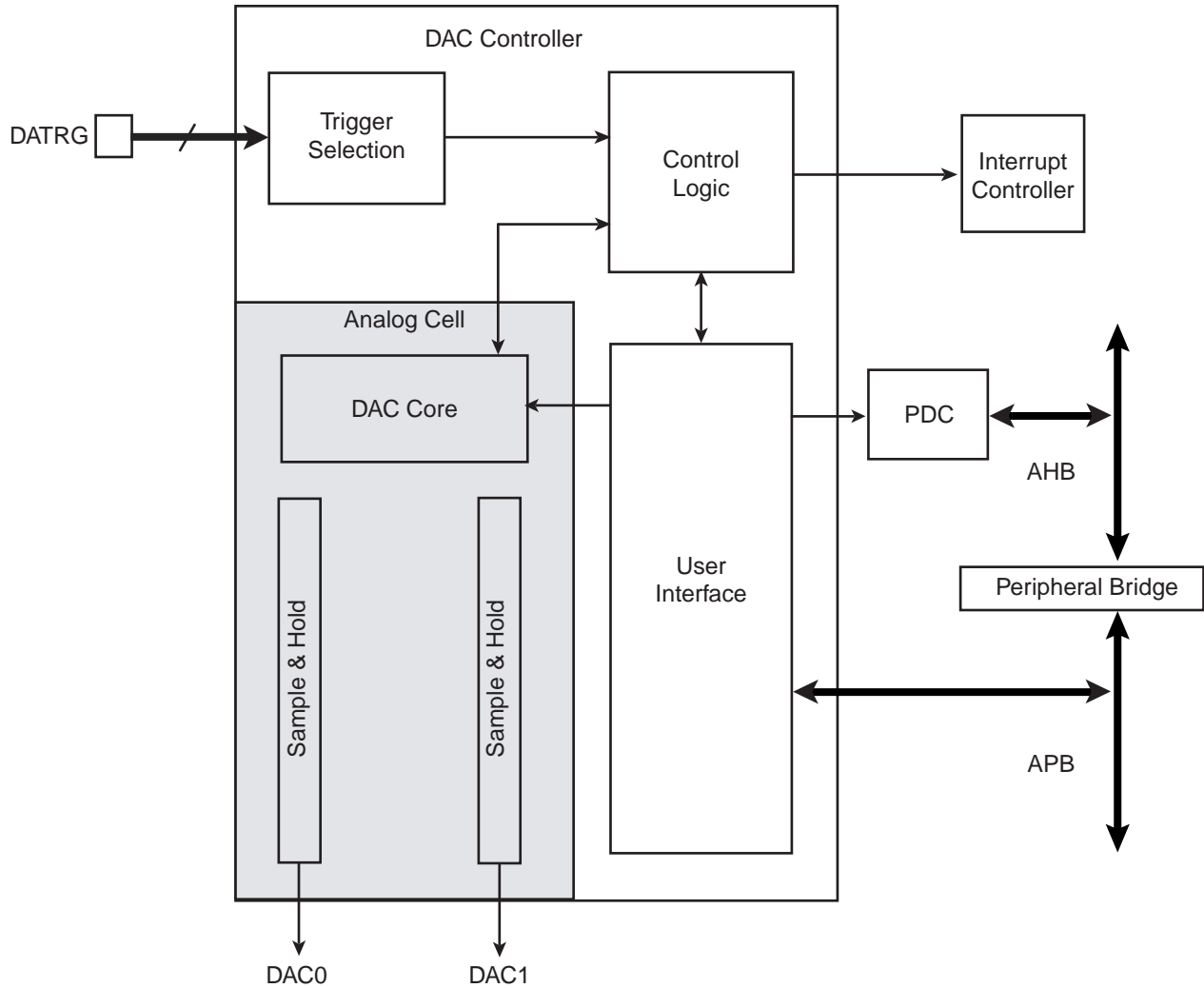

41.4 Signal Description

Table 41-1. DACC Pin Description

Pin Name	Description
DAC0 - DAC1	Analog output channels
DATRG	External triggers

41.5 Product Dependencies

41.5.1 Power Management

The DACC becomes active as soon as a conversion is requested and at least one channel is enabled. The DACC is automatically deactivated when no channels are enabled.

For power saving options see [Section 41.6.6 "Sleep Mode"](#).

41.5.2 Interrupt Sources

The DACC interrupt line is connected on one of the internal sources of the interrupt controller. Using the DACC interrupt requires the interrupt controller to be programmed first.

Table 41-2. Peripheral IDs

Instance	ID
DACC	30

41.5.3 Conversion Performances

For performance and electrical characteristics of the DACC, see the product DC Characteristics section.

41.6 Functional Description

41.6.1 Digital-to-Analog Conversion

The DACC uses the master clock (MCK) divided by two to perform conversions. This clock is named DACC Clock. Once a conversion starts the DACC takes 25 clock periods to provide the analog result on the selected analog output.

41.6.2 Conversion Results

When a conversion is completed, the resulting analog value is available at the selected DACC channel output and the EOC bit in the [DACC Interrupt Status Register](#), is set.

Reading the DACC_ISR register clears the EOC bit.

41.6.3 Conversion Triggers

In free running mode, conversion starts as soon as at least one channel is enabled and data is written in the [DACC Conversion Data Register](#), then 25 DACC Clock periods later, the converted data is available at the corresponding analog output as stated above.

In external trigger mode, the conversion waits for a rising edge on the selected trigger to begin.

Warning: Disabling the external trigger mode automatically sets the DACC in free running mode.

41.6.4 Conversion FIFO

A 4 half-word FIFO is used to handle the data to be converted.

As long as the TXRDY flag in the [DACC Interrupt Status Register](#) is active the DAC Controller is ready to accept conversion requests by writing data into [DACC Conversion Data Register](#). Data which cannot be converted immediately are stored in the DACC FIFO.

When the FIFO is full or the DACC is not ready to accept conversion requests, the TXRDY flag is inactive.

The WORD field of the [DACC Mode Register](#) allows the user to switch between half-word and word transfer for writing into the FIFO.

In half-word transfer mode only the 16 LSB of DACC_CDR data are taken into account, DACC_CDR[15:0] is stored into the FIFO.

DACC_CDR[11:0] field is used as data and the DACC_CDR[15:12] bits are used for channel selection if the TAG field is set in DACC_MR register.

In word transfer mode each time the DACC_CDR register is written 2 data items are stored in the FIFO. The first data item sampled for conversion is DACC_CDR[15:0] and the second DACC_CDR[31:16].

Fields DACC_CDR[15:12] and DACC_CDR[31:28] are used for channel selection if the TAG field is set in DACC_MR register.

Warning: Writing in the DACC_CDR register while TXRDY flag is inactive will corrupt FIFO data.

41.6.5 Channel Selection

There are two means by which to select the channel to perform data conversion.

- By default, to select the channel where to convert the data, is to use the USER_SEL field of the [DACC Mode Register](#). Data requests will merely be converted to the channel selected with the USER_SEL field.
- A more flexible option to select the channel for the data to be converted to is to use the tag mode, setting the TAG field of the [DACC Mode Register](#) to 1. In this mode the 2 bits, DACC_CDR[13:12] which are otherwise unused, are employed to select the channel in the same way as with the USER_SEL field. Finally, if the WORD field is set, the 2 bits, DACC_CDR[13:12] are used for channel selection of the first data and the 2 bits, DACC_CDR[29:28] for channel selection of the second data.

41.6.6 Sleep Mode

The DACC Sleep Mode maximizes power saving by automatically deactivating the DACC when it is not being used for conversions.

When a start conversion request occurs, the DACC is automatically activated. As the analog cell requires a start-up time, the logic waits during this time and starts the conversion on the selected channel. When all conversion requests are complete, the DACC is deactivated until the next request for conversion.

A fast wake-up mode is available in the [DACC Mode Register](#) as a compromise between power saving strategy and responsiveness. Setting the FASTW bit to 1 enables the fast wake-up mode. In fast wake-up mode the DACC is not fully deactivated while no conversion is requested, thereby providing less power saving but faster wake-up (4 times faster).

41.6.7 DACC Timings

The DACC startup time must be defined by the user in the STARTUP field of the [DACC Mode Register](#).

This startup time differs depending of the use of the fast wake-up mode along with sleep mode, in this case the user must set the STARTUP time corresponding to the fast wake up and not the standard startup time.

A max speed mode is available by setting the MAXS bit to 1 in the DACC_MR register. Using this mode, the DAC Controller no longer waits to sample the end of cycle signal coming from the DACC block to start the next conversion and uses an internal counter instead. This mode gains 2 DACC Clock periods between each consecutive conversion.

Warning: Using this mode, the EOC interrupt of the DACC_IER register should not be used as it is 2 DACC Clock periods late.

After 20 μ s the analog voltage resulting from the converted data will start decreasing, therefore it is necessary to refresh the channel on a regular basis to prevent this voltage loss. This is the purpose of the REFRESH field in the DACC Mode Register where the user will define the period for the analog channels to be refreshed.

Warning: A REFRESH PERIOD field set to 0 will disable the refresh function of the DACC channels.

Figure 41-2. Conversion Sequence

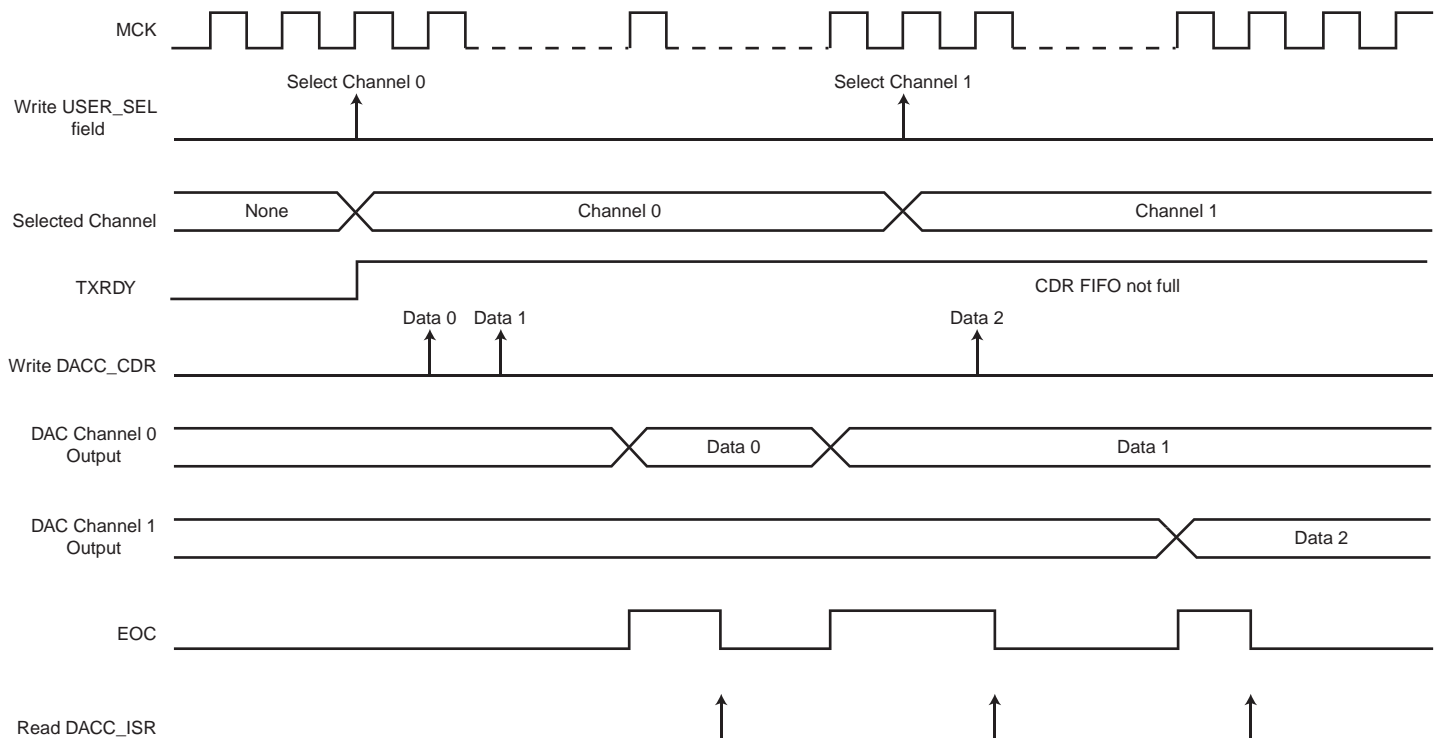

41.6.8 Write Protection Registers

In order to provide security to the DACC, a write protection system has been implemented.

The write protection mode prevents the writing of certain registers. When this mode is enabled and one of the protected registers is written, an error is generated in the [DACC Write Protect Status Register](#) and the register write request is canceled. When a write protection error occurs, the WPROTERR flag is set and the address of the corresponding canceled register write is available in the WPROTADRR field of the [DACC Write Protect Status Register](#).

Due to the nature of the write protection feature, enabling and disabling the write protection mode requires the use of a security code. Thus when enabling or disabling the write protection mode the WPKEY field of the [DACC Write Protect Mode Register](#) must be filled with the “DAC” ASCII code (corresponding to 0x444143) otherwise the register write is canceled.

The protected registers are:

[DACC Mode Register](#)

[DACC Channel Enable Register](#)

[DACC Channel Disable Register](#)

[DACC Analog Current Register](#)

41.7 Digital-to-Analog Converter Controller (DACC) User Interface

Table 41-3. Register Mapping

Offset	Register	Name	Access	Reset
0x00	Control Register	DACC_CR	Write-only	–
0x04	Mode Register	DACC_MR	Read-write	0x00000000
0x08	Reserved	–	–	–
0x0C	Reserved	–	–	–
0x10	Channel Enable Register	DACC_CHER	Write-only	–
0x14	Channel Disable Register	DACC_CHDR	Write-only	–
0x18	Channel Status Register	DACC_CHSR	Read-only	0x00000000
0x1C	Reserved	–	–	–
0x20	Conversion Data Register	DACC_CDR	Write-only	0x00000000
0x24	Interrupt Enable Register	DACC_IER	Write-only	–
0x28	Interrupt Disable Register	DACC_IDR	Write-only	–
0x2C	Interrupt Mask Register	DACC_IMR	Read-only	0x00000000
0x30	Interrupt Status Register	DACC_ISR	Read-only	0x00000000
0x94	Analog Current Register	DACC_ACR	Read-write	0x00000000
0xE4	Write Protect Mode register	DACC_WPMR	Read-write	0x00000000
0xE8	Write Protect Status register	DACC_WPSR	Read-only	0x00000000
...
0xEC - 0xFC	Reserved	–	–	–



41.7.1 DACC Control Register

Name: DACC_CR

Address: 0x4003C000

Access: Write-only

31	30	29	28	27	26	25	24
–	–	–	–	–	–	–	–
23	22	21	20	19	18	17	16
–	–	–	–	–	–	–	–
15	14	13	12	11	10	9	8
–	–	–	–	–	–	–	–
7	6	5	4	3	2	1	0
–	–	–	–	–	–	–	SWRST

- **SWRST: Software Reset**

0 = No effect.

1 = Resets the DACC simulating a hardware reset.

41.7.2 DACC Mode Register

Name: DACC_MR
Address: 0x4003C004
Access: Read-write

31	30	29	28	27	26	25	24
-		-		STARTUP			
23	22	21	20	19	18	17	16
-		MAXS	TAG	-		USER_SEL	
15	14	13	12	11	10	9	8
REFRESH							
7	6	5	4	3	2	1	0
-		FASTWKUP	SLEEP	WORD	TRGSEL		TRGEN

This register can only be written if the WPEN bit is cleared in [DACC Write Protect Mode Register](#).

- TRGEN: Trigger Enable**

Value	Name	Description
0	DIS	External trigger mode disabled. DACC in free running mode.
1	EN	External trigger mode enabled.

- TRGSEL: Trigger Selection**

TRGSEL			Selected TRGSEL
0	0	0	External trigger
0	0	1	TIO Output of the Timer Counter Channel 0
0	1	0	TIO Output of the Timer Counter Channel 1
0	1	1	TIO Output of the Timer Counter Channel 2
1	0	0	PWM Event Line 0
1	0	1	PWM Event Line 1
1	1	0	Reserved
1	1	1	Reserved

- WORD: Word Transfer**

Value	Name	Description
0	HALF	Half-Word transfer
1	WORD	Word Transfer

- **SLEEP: Sleep Mode**

SLEEP	Selected Mode
0	Normal Mode
1	Sleep Mode

0 = Normal Mode: The DAC Core and reference voltage circuitry are kept ON between conversions.

After reset, the DAC is in normal mode but with the voltage reference and the DAC core off. For the first conversion, a startup time must be defined in the STARTUP field. Note that in this mode, STARTUP time is only required once, at start up.

1 = Sleep Mode: The DAC Core and reference voltage circuitry are OFF between conversions.

- **FASTWKUP: Fast Wake up Mode**

FASTWKUP	Selected Mode
0	Normal Sleep Mode
1	Fast Wake up Sleep Mode

0 = Normal Sleep Mode: The sleep mode is defined by the SLEEP bit.

1 = Fast Wake Up Sleep Mode: The voltage reference is ON between conversions and DAC Core is OFF.

- **REFRESH: Refresh Period**

Refresh Period = $1024 * \text{REFRESH} / \text{DACC Clock}$

- **USER_SEL: User Channel Selection**

Value	Name	Description
0	CHANNEL0	Channel 0
1	CHANNEL1	Channel 1
2		Reserved
3		Reserved

- **TAG: Tag Selection Mode**

Value	Name	Description
0	DIS	Tag selection mode disabled. Using USER_SEL to select the channel for the conversion.
1	EN	Tag selection mode enabled

- **MAXS: Max Speed Mode**

MAX SPEED	Selected Mode
0	Normal Mode
1	Max Speed Mode enabled

- **STARTUP: Startup Time Selection**

Value	Name	Description
0	0	0 periods of DACClock
1	8	8 periods of DACClock
2	16	16 periods of DACClock
3	24	24 periods of DACClock
4	64	64 periods of DACClock
5	80	80 periods of DACClock
6	96	96 periods of DACClock
7	112	112 periods of DACClock
8	512	512 periods of DACClock
9	576	576 periods of DACClock
10	640	640 periods of DACClock
11	704	704 periods of DACClock
12	768	768 periods of DACClock
13	832	832 periods of DACClock
14	896	896 periods of DACClock
15	960	960 periods of DACClock
16	1024	1024 periods of DACClock
17	1088	1088 periods of DACClock
18	1152	1152 periods of DACClock
19	1216	1216 periods of DACClock
20	1280	1280 periods of DACClock
21	1344	1344 periods of DACClock
22	1408	1408 periods of DACClock
23	1472	1472 periods of DACClock
24	1536	1536 periods of DACClock
25	1600	1600 periods of DACClock
26	1664	1664 periods of DACClock
27	1728	1728 periods of DACClock
28	1792	1792 periods of DACClock
29	1856	1856 periods of DACClock
30	1920	1920 periods of DACClock
31	1984	1984 periods of DACClock

Value	Name	Description
32	2048	2048 periods of DACClock
33	2112	2112 periods of DACClock
34	2176	2176 periods of DACClock
35	2240	2240 periods of DACClock
36	2304	2304 periods of DACClock
37	2368	2368 periods of DACClock
38	2432	2432 periods of DACClock
39	2496	2496 periods of DACClock
40	2560	2560 periods of DACClock
41	2624	2624 periods of DACClock
42	2688	2688 periods of DACClock
43	2752	2752 periods of DACClock
44	2816	2816 periods of DACClock
45	2880	2880 periods of DACClock
46	2944	2944 periods of DACClock
47	3008	3008 periods of DACClock
48	3072	3072 periods of DACClock
49	3136	3136 periods of DACClock
50	3200	3200 periods of DACClock
51	3264	3264 periods of DACClock
52	3328	3328 periods of DACClock
53	3392	3392 periods of DACClock
54	3456	3456 periods of DACClock
55	3520	3520 periods of DACClock
56	3584	3584 periods of DACClock
57	3648	3648 periods of DACClock
58	3712	3712 periods of DACClock
59	3776	3776 periods of DACClock
60	3840	3840 periods of DACClock
61	3904	3904 periods of DACClock
62	3968	3968 periods of DACClock
63	4032	4032 periods of DACClock

Note: Refer to the product DAC electrical characteristics section for Startup Time value.

41.7.3 DACC Channel Enable Register

Name: DACC_CHER

Address: 0x4003C010

Access: Write-only

31	30	29	28	27	26	25	24
–	–	–	–	–	–	–	–
23	22	21	20	19	18	17	16
–	–	–	–	–	–	–	–
15	14	13	12	11	10	9	8
–	–	–	–	–	–	–	–
7	6	5	4	3	2	1	0
–	–	–	–	–		CH1	CH0

This register can only be written if the WPEN bit is cleared in [DACC Write Protect Mode Register](#).

- **CHx: Channel x Enable**

0 = No effect.

1 = Enables the corresponding channel.

41.7.4 DACC Channel Disable Register

Name: DACC_CHDR

Address: 0x4003C014

Access: Write-only

31	30	29	28	27	26	25	24
–	–	–	–	–	–	–	–
23	22	21	20	19	18	17	16
–	–	–	–	–	–	–	–
15	14	13	12	11	10	9	8
–	–	–	–	–	–	–	–
7	6	5	4	3	2	1	0
–	–	–	–	–		CH1	CH0

This register can only be written if the WPEN bit is cleared in [DACC Write Protect Mode Register](#).

- **CHx: Channel x Disable**

0 = No effect.

1 = Disables the corresponding channel.

Warning: If the corresponding channel is disabled during a conversion or if it is disabled then re-enabled during a conversion, its associated analog value and its corresponding EOC flags in DACC_ISR are unpredictable.

41.7.5 DACC Channel Status Register

Name: DACC_CHSR

Address: 0x4003C018

Access: Read-only

31	30	29	28	27	26	25	24
–	–	–	–	–	–	–	–
23	22	21	20	19	18	17	16
–	–	–	–	–	–	–	–
15	14	13	12	11	10	9	8
–	–	–	–	–	–	–	–
7	6	5	4	3	2	1	0
–	–	–	–	–		CH1	CH0

- **CHx: Channel x Status**

0 = Corresponding channel is disabled.

1 = Corresponding channel is enabled.

41.7.6 DACC Conversion Data Register

Name: DACC_CDR

Address: 0x4003C020

Access: Write-only

31	30	29	28	27	26	25	24
DATA							
23	22	21	20	19	18	17	16
DATA							
15	14	13	12	11	10	9	8
DATA							
7	6	5	4	3	2	1	0
DATA							

- **DATA: Data to Convert**

When the WORD bit in DACC_MR register is cleared, only DATA[15:0] is used else DATA[31:0] is used to write 2 data to be converted.



41.7.7 DACC Interrupt Enable Register

Name: DACC_IER

Address: 0x4003C024

Access: Write-only

31	30	29	28	27	26	25	24
–	–	–	–	–	–	–	–
23	22	21	20	19	18	17	16
–	–	–	–	–	–	–	–
15	14	13	12	11	10	9	8
–	–	–	–	–	–	–	–
7	6	5	4	3	2	1	0
–	–	–	–	TXBUFE	ENDTX	EOC	TXRDY

- **TXRDY:** Transmit Ready Interrupt Enable
- **EOC:** End of Conversion Interrupt Enable
- **ENDTX:** End of Transmit Buffer Interrupt Enable
- **TXBUFE:** Transmit Buffer Empty Interrupt Enable

41.7.8 DACC Interrupt Disable Register

Name: DACC_IDR

Address: 0x4003C028

Access: Write-only

31	30	29	28	27	26	25	24
–	–	–	–	–	–	–	–
23	22	21	20	19	18	17	16
–	–	–	–	–	–	–	–
15	14	13	12	11	10	9	8
–	–	–	–	–	–	–	–
7	6	5	4	3	2	1	0
–	–	–	–	TXBUFE	ENDTX	EOC	TXRDY

- **TXRDY:** Transmit Ready Interrupt Disable.
- **EOC:** End of Conversion Interrupt Disable
- **ENDTX:** End of Transmit Buffer Interrupt Disable
- **TXBUFE:** Transmit Buffer Empty Interrupt Disable



41.7.9 DACC Interrupt Mask Register

Name: DACC_IMR

Address: 0x4003C02C

Access: Read-only

31	30	29	28	27	26	25	24
–	–	–	–	–	–	–	–
23	22	21	20	19	18	17	16
–	–	–	–	–	–	–	–
15	14	13	12	11	10	9	8
–	–	–	–	–	–	–	–
7	6	5	4	3	2	1	0
–	–	–	–	TXBUFE	ENDTX	EOC	TXRDY

- **TXRDY:** Transmit Ready Interrupt Mask
- **EOC:** End of Conversion Interrupt Mask
- **ENDTX:** End of Transmit Buffer Interrupt Mask
- **TXBUFE:** Transmit Buffer Empty Interrupt Mask

41.7.10 DACC Interrupt Status Register

Name: DACC_ISR
Address: 0x4003C030
Access: Read-only

31	30	29	28	27	26	25	24
–	–	–	–	–	–	–	–
23	22	21	20	19	18	17	16
–	–	–	–	–	–	–	–
15	14	13	12	11	10	9	8
–	–	–	–	–	–	–	–
7	6	5	4	3	2	1	0
–	–	–	–	TXBUFE	ENDTX	EOC	TXRDY

- **TXRDY: Transmit Ready Interrupt Flag**

0 = DACC is not ready to accept new conversion requests.

1 = DACC is ready to accept new conversion requests.

- **EOC: End of Conversion Interrupt Flag**

0 = No conversion has been performed since the last DACC_ISR read.

1 = At least one conversion has been performed since the last DACC_ISR read.

- **ENDTX: End of DMA Interrupt Flag**

0 = The Transmit Counter Register has not reached 0 since the last write in DACC_TCR or DACC_TNCR.

1 = The Transmit Counter Register has reached 0 since the last write in DACC_TCR or DACC_TNCR

- **TXBUFE: Transmit Buffer Empty**

0 = The Transmit Counter Register has not reached 0 since the last write in DACC_TCR or DACC_TNCR.

1 = The Transmit Counter Register has reached 0 since the last write in DACC_TCR or DACC_TNCR.

41.7.11 DACC Analog Current Register

Name: DACC_ACR

Address: 0x4003C094

Access: Read-write

31	30	29	28	27	26	25	24
–	–	–	–	–	–	–	–
23	22	21	20	19	18	17	16
–	–	–	–	–	–	–	–
15	14	13	12	11	10	9	8
–	–	–	–	–	–	IBCTLDACCORE	
7	6	5	4	3	2	1	0
–	–	–	–	IBCTLCH1		IBCTLCH0	

This register can only be written if the WPEN bit is cleared in [DACC Write Protect Mode Register](#).

- **IBCTLCHx: Analog Output Current Control**

Allows to adapt the slew rate of the analog output. (See the product electrical characteristics for further details.)

- **IBCTLDACCORE: Bias Current Control for DAC Core**

Allows to adapt performance versus power consumption. (See the product electrical characteristics for further details.)

41.7.12 DACC Write Protect Mode Register

Name: DACC_WPMR

Address: 0x4003C0E4

Access: Read-write

31	30	29	28	27	26	25	24
WPKEY							
23	22	21	20	19	18	17	16
WPKEY							
15	14	13	12	11	10	9	8
WPKEY							
7	6	5	4	3	2	1	0
-	-	-	-	-	-	-	WPEN

- **WPEN: Write Protect Enable**

0 = Disables the Write Protect if WPKEY corresponds to 0x444143 (“DAC” in ASCII).

1 = Enables the Write Protect if WPKEY corresponds to 0x444143 (“DAC” in ASCII).

The protected registers are:

[DACC Mode Register](#)

[DACC Channel Enable Register](#)

[DACC Channel Disable Register](#)

[DACC Analog Current Register](#)

- **WPKEY: Write Protect KEY**

This security code is needed to set/reset the WPROT bit value (see [Section 41.6.8 “Write Protection Registers”](#) for details).

Must be filled with “DAC” ASCII code.

41.7.13 DACC Write Protect Status Register

Name: DACC_WPSR

Address: 0x4003C0E8

Access: Read-only

31	30	29	28	27	26	25	24
–	–	–	–	–	–	–	–
23	22	21	20	19	18	17	16
–	–	–	–	–	–	–	–
15	14	13	12	11	10	9	8
WPROTADDR							
7	6	5	4	3	2	1	0
–	–	–	–	–	–	–	WPROTERR

- **WPROTADDR: Write protection error address**

Indicates the address of the register write request which generated the error.

- **WPROTERR: Write protection error**

Indicates a write protection error.

42. SAM4S Electrical Characteristics

42.1 Absolute Maximum Ratings

Table 42-1. Absolute Maximum Ratings*

Operating Temperature (Industrial)	-40°C to + 85°C
Storage Temperature.....	-60°C to + 150°C
Voltage on Input Pins with Respect to Ground.....	-0.3V to + 4.0V
Maximum Operating Voltage (VDDCORE).....	1.32V
Maximum Operating Voltage (VDDIO).....	4.0V
Total DC Output Current on all I/O lines	
100-lead LQFP.....	150 mA
100-ball TFBGA.....	150 mA
100-ball VFBGA.....	150 mA
64-lead LQFP.....	100 mA
64-lead QFN.....	100 mA

*NOTICE: Stresses beyond those listed under “Absolute Maximum Ratings” may cause permanent damage to the device. This is a stress rating only and functional operation of the device at these or other conditions beyond those indicated in the operational sections of this specification is not implied. **Exposure to absolute maximum rating conditions for extended periods may affect device reliability.**

42.2 DC Characteristics

The following characteristics are applicable to the operating temperature range: $T_A = -40^{\circ}\text{C}$ to 85°C , unless otherwise specified.

Table 42-2. DC Characteristics

Symbol	Parameter	Conditions	Min	Typ	Max	Units
V_{DDCORE}	DC Supply Core		1.08	1.20	1.32	V
V_{VDDIO}	DC Supply I/Os	(2) (3)	1.62	3.3	3.6	V
V_{VDDPLL}	PLL A, PLLB and Main Oscillator Supply		1.08		1.32	V
V_{IL}	Input Low-level Voltage	PA0-PA31, PB0-PB14, PC0-PC31	-0.3		MIN [0.8V:0.3 x V_{VDDIO}]	V
V_{IH}	Input High-level Voltage	PA0-PA31, PB0-PB14, PC0-PC31	MIN[2.0V:0.7 x V_{VDDIO}]		$V_{\text{VDDIO}} + 0.3\text{V}$	V
V_{OH}	Output High-level Voltage	PA0-PA31, PB0-PB9, PB12-PB14, PC0-PC31 $I_{\text{OL}} = 4.0\text{ mA}$	$V_{\text{VDDIO}} - 0.4\text{V}$			V
		VDDIO [3.0V : 3.60V] PB10-PB11	$V_{\text{VDDIO}} - 0.15\text{V}$			
V_{OL}	Output Low-level Voltage	PA0-PA31, PB0-PB9, PB12-PB14, PC0-PC31 $I_{\text{OH}} = 4.0\text{ mA}$			0.4	V
		VDDIO [3.0V : 3.60V] PB10-PB11			0.15	
V_{Hys}	Hysteresis Voltage	PA0-PA31, PB0-PB9, PB12-PB14, PC0-PC31 (Hysteresis mode enabled)	150			mV
I_{O}	I_{OH} (or I_{SOURCE})	VDDIO [1.65V : 3.60V] ; $V_{\text{OH}} = V_{\text{VDDIO}} - 0.4\text{V}$ - PA14 (SPCK), PA29 (MCCK) pins - PA[12-13], PA[26-28], PA[30-31] pins - PA[0-3] - Other pins ⁽¹⁾			-4 -4 -2 -2	mA
		VDDIO [3.0V : 3.60V] - PB[10-11]			-30	
		VDDIO [1.65V : 3.60V] ; $V_{\text{OH}} = V_{\text{VDDIO}} - 0.4\text{V}$ - NRST			-2	
I_{O}	I_{OL} (or I_{SINK})	VDDIO [1.65V : 3.60V] ; $V_{\text{OL}} = 0.4\text{V}$ - PA14 (SPCK), PA29 (MCCK) pins - PA[12-13], PA[26-28], PA[30-31] pins - PA[0-3] - Other pins ⁽¹⁾			4 4 2 2	mA
		VDDIO [3.0V : 3.60V] - PB[10-11]			30	
		VDDIO [1.65V : 3.60V] ; $V_{\text{OL}} = 0.4\text{V}$ - NRST			2	
I_{IL}	Input Low	Pull_up OFF	-1		1	μA
		Pull_up ON	10		50	

Table 42-2. DC Characteristics (Continued)

Symbol	Parameter	Conditions	Min	Typ	Max	Units
I _{IH}	Input High	Pull_down OFF	-1		1	μA
		Pull_down ON	10		50	
R _{PULLUP}	Pull-up Resistor	PA0-PA31, PB0-PB14, PC0-PC31 NRST	70	100	130	kΩ
R _{PULLDOWN}	Pull-down Resistor	PA0-PA31, PB0-PB14, PC0-PC31 NRST	70	100	130	kΩ
R _{ODT}	On-die Series Termination Resistor	PA4-PA31, PB0-PB9, PB12-PB14, PC0-PC31		36		Ω
		PA0-PA3		18		

- Note:
1. PA[4-11], PA[15-25], PB[0-9], PB[12-14], PC[0-31]
 2. At power-up VDDIO needs to reach 0.6V before VDDIN reaches 1.0V
 3. VDDIO voltage needs to be equal or below to (VDDIN voltage +0.5V)

Table 42-3. 1.2V Voltage Regulator Characteristics

Symbol	Parameter	Conditions	Min	Typ	Max	Units
V _{VDDIN}	DC Input Voltage Range	(4) (5)	1.6	3.3	3.6	V
V _{VDDOUT}	DC Output Voltage	Normal Mode Standby Mode		1.2 0		V
V _{ACCURACY}	Output Voltage Accuracy	I _{Load} = 0.8mA to 80 mA (after trimming)	-3		3	%
I _{LOAD}	Maximum DC Output Current	V _{VDDIN} > 1.8V V _{VDDIN} ≤ 1.8V			80 40	mA
I _{LOAD-START}	Maximum Peak Current during startup	See Note ⁽³⁾ .			400	mA
D _{DROPOUT}	Dropout Voltage	V _{VDDIN} = 1.6V, I _{Load} = Max		400		mV
V _{LINE}	Line Regulation	V _{VDDIN} from 2.7V to 3.6V; I _{Load} MAX		10	30	mV
V _{LINE-TR}	Transient Line regulation	V _{VDDIN} from 2.7V to 3.6V; tr = tf = 5μs; I _{Load} Max		50	150	
V _{LOAD}	Load Regulation	V _{VDDIN} ≥ 1.8V; I _{Load} = 10% to 90% MAX V _{VDDIN} ≥ 1.8V;		20	40	mV
V _{LOAD-TR}	Transient Load Regulation	I _{Load} = 10% to 90% MAX tr = tf = 5 μs		50	150	
I _Q	Quiescent Current	Normal Mode; @ I _{Load} = 0 mA @ I _{Load} = 80 mA Standby Mode;		5 500	1	μA
CD _{IN}	Input Decoupling Capacitor	Cf. External Capacitor Requirements ⁽¹⁾		4.7		μF
CD _{OUT}	Output Decoupling Capacitor	Cf. External Capacitor Requirements ⁽²⁾	1.85	2.2	5.9	μF
		ESR	0.1		10	Ohm
T _{ON}	Turn on Time	CD _{OUT} = 2.2μF, V _{VDDOUT} reaches 1.2V (+/- 3%)		300		μs
T _{OFF}	Turn off Time	CD _{OUT} = 2.2μF			40	ms

- Notes:
1. A 10μF or higher ceramic capacitor must be connected between VDDIN and the closest GND pin of the device. This large decoupling capacitor is mandatory to reduce startup current, improving transient response and noise rejection.
 2. To ensure stability, an external 2.2μF output capacitor, CD_{OUT} must be connected between the VDDOUT and the closest GND pin of the device. The ESR (Equivalent Series Resistance) of the capacitor must be in the range 0.1 to 10 ohms. Solid tantalum, and multilayer ceramic capacitors are all suitable as output capacitor. A 100nF bypass capacitor between VDDOUT and the closest GND pin of the device helps decreasing output noise and improves the load transient response.
 3. Defined as the current needed to charge external bypass/decoupling capacitor network.
 4. At power-up VDDIO needs to reach 0.6V before VDDIN reaches 1.0V
 5. VDDIO voltage needs to be equal or below to (VDDIN voltage +0.5V)

Table 42-4. Core Power Supply Brownout Detector Characteristics

Symbol	Parameter	Conditions	Min	Typ	Max	Units
V_{TH-}	Supply Falling Threshold ⁽¹⁾		0.98	1.0	1.04	V
V_{HYST}	Hysteresis				110	mV
V_{TH+}	Supply Rising Threshold		0.8	1.0	1.08	V
I_{DDON}	Current Consumption on VDDCORE	Brownout Detector enabled			24	μ A
I_{DDOFF}		Brownout Detector disabled			2	μ A
I_{DD33ON}	Current Consumption on VDDIO	Brownout Detector enabled			24	μ A
$I_{DD33OFF}$		Brownout Detector disabled			2	μ A
T_{d-}	V_{TH-} detection propagation time	$V_{DDCORE} = V_{TH+}$ to $(V_{TH-} - 100mV)$		200	300	ns
T_{START}	Startup Time	From disabled state to enabled state			300	μ s

Note: 1. The product is guaranteed to be functional at V_{TH-} .

Figure 42-1. Core Brownout Output Waveform

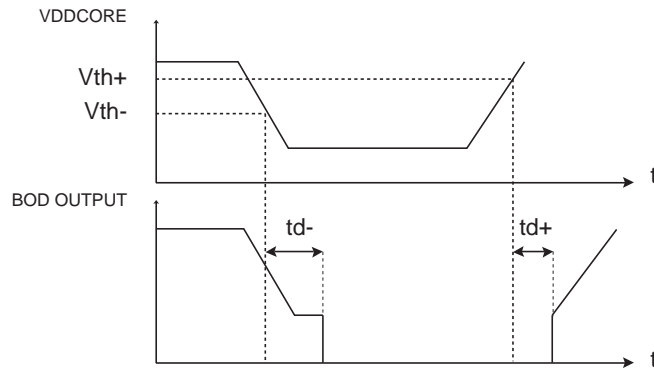

Table 42-5. VDDIO Supply Monitor

Symbol	Parameter	Conditions	Min	Typ	Max	Units
V_{TH}	Supply Monitor Threshold	16 selectable steps	1.6		3.4	V
$T_{ACCURACY}$	Threshold Level Accuracy	$[-40/+85^{\circ}C]$	-2.5		+2.5	%
V_{HYST}	Hysteresis			20	30	mV
I_{DDON}	Current Consumption on VDDCORE	Enabled			40	μ A
I_{DDOFF}		Disabled			10	
T_{START}	Startup Time	From disabled state to enabled state			320	μ s

Table 42-6. Threshold Selection

Digital Code	Threshold min (V)	Threshold typ (V)	Threshold max (V)
0000	1.58	1.6	1.62
0001	1.7	1.72	1.74
0010	1.82	1.84	1.86
0011	1.94	1.96	1.98
0100	2.05	2.08	2.11
0101	2.17	2.2	2.23
0110	2.29	2.32	2.35
0111	2.41	2.44	2.47
1000	2.53	2.56	2.59
1001	2.65	2.68	2.71
1010	2.77	2.8	2.83
1011	2.8	2.92	2.95
1100	3.0	3.04	3.07
1101	3.12	3.16	3.2
1110	3.24	3.28	3.32
1111	3.36	3.4	3.44

Figure 42-2. VDDIO Supply Monitor

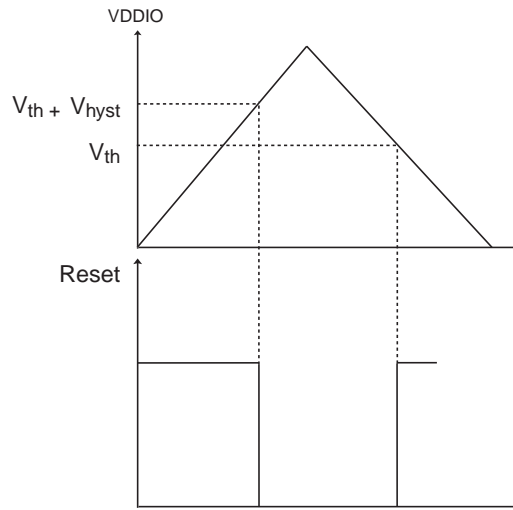

Table 42-7. Zero-Power-on Reset Characteristics

Symbol	Parameter	Conditions	Min	Typ	Max	Units
V_{th+}	Threshold voltage rising	At Startup	1.45	1.53	1.59	V
V_{th-}	Threshold voltage falling		1.35	1.45	1.55	V
Tres	Reset Time-out Period		100	240	500	μ s

Figure 42-3. Zero-Power-on Reset Characteristics

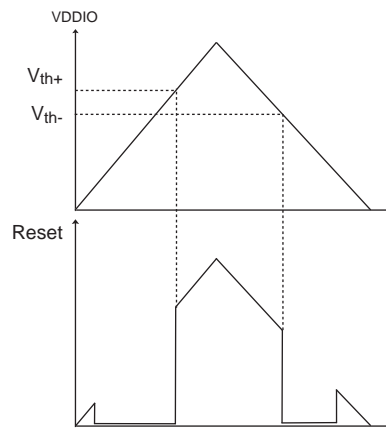

Table 42-8. DC Flash Characteristics

Symbol	Parameter	Conditions	Typ	Max	Units
I_{CC}	Active current	Random 144-bit Read: Maximum Read Frequency onto VDDCORE = 1.2V @ 25°C	16	25	mA
		Random 72-bit Read: Maximum Read Frequency onto VDDCORE = 1.2V @ 25°C	10	18	mA
		Program onto VDDCORE = 1.2V @ 25°C	3	5	mA

42.3 Power Consumption

- Power consumption of the device according to the different Low Power Mode Capabilities (Backup, Wait, Sleep) and Active Mode.
- Power consumption on power supply in different modes: Backup, Wait, Sleep and Active.
- Power consumption by peripheral: calculated as the difference in current measurement after having enabled then disabled the corresponding clock.

42.3.1 Backup Mode Current Consumption

The Backup Mode configuration and measurements are defined as follows.

Figure 42-4. Measurement Setup

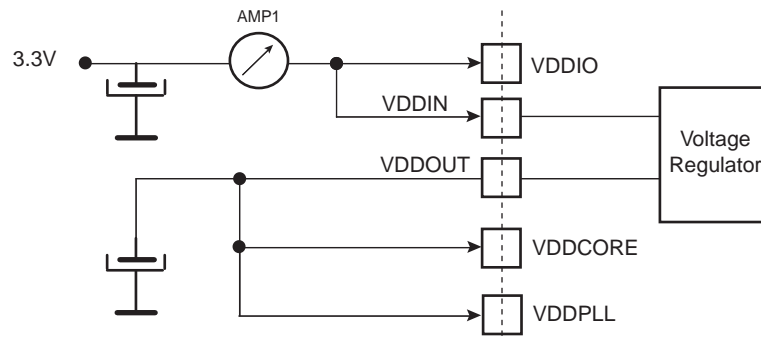

42.3.1.1 Configuration A

- Supply Monitor on VDDIO is disabled
- RTT and RTC not used
- Embedded slow clock RC Oscillator used
- One WKUPx enabled
- Current measurement on AMP1 (See [Figure 42-4](#))

42.3.1.2 Configuration B

- Supply Monitor on VDDIO is disabled
- RTT used
- One WKUPx enabled
- Current measurement on AMP1 (See [Figure 42-4](#))
- 32 KHz Crystal Oscillator used

Table 42-9. Power Consumption for Backup Mode Configuration A and B

Conditions	Total Consumption (AMP1) Configuration A	Total Consumption (AMP1) Configuration B	Unit
VDDIO = 3.3V @25°C	1.98	1.85	μA
VDDIO = 3.0V @25°C	1.79	1.66	
VDDIO = 2.5V @25°C	1.51	1.37	
VDDIO = 1.8V @25°C	1	0.95	
VDDIO = 3.3V @85°C	13.0	12.42	μA
VDDIO = 3.0V @85°C	12.0	11.42	
VDDIO = 2.5V @85°C	10.5	10.05	
VDDIO = 1.8V @85°C	8.78	8.42	

42.3.2 Sleep and Wait Mode Current Consumption

The Wait Mode and Sleep Mode configuration and measurements are defined below.

Figure 42-5. Measurement Setup for Sleep Mode

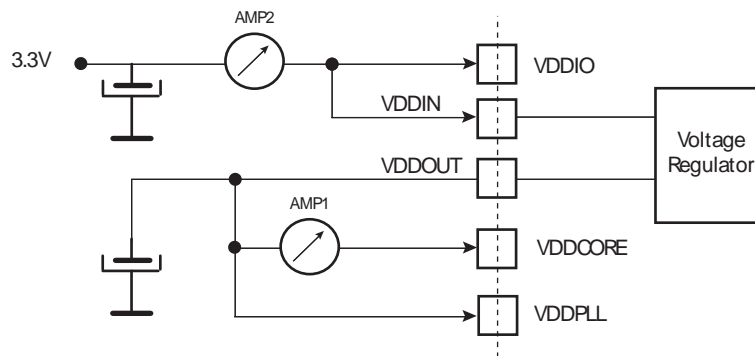

42.3.2.1 Sleep Mode

- Core Clock OFF
- Master Clock (MCK) running at various frequencies with PLLA or the fast RC oscillator.
- Fast start-up through WKUP0-15 pins
- Current measurement as shown in figure [Figure 42-6](#)
- All peripheral clocks deactivated

[Table 42-10](#) below gives current consumption in typical conditions.

Table 42-10. Typical Current Consumption for Sleep Mode

Conditions	VDDCORE Consumption (AMP1)	Total Consumption (AMP2)	Unit
Figure 42-6 on page 1102 @25°C MCK = 48 MHz There is no activity on the I/Os of the device.	2.52	3.04	mA

Figure 42-6. Current Consumption in Sleep Mode (AMP1) versus Master Clock ranges (Condition from [Table 42-10](#))

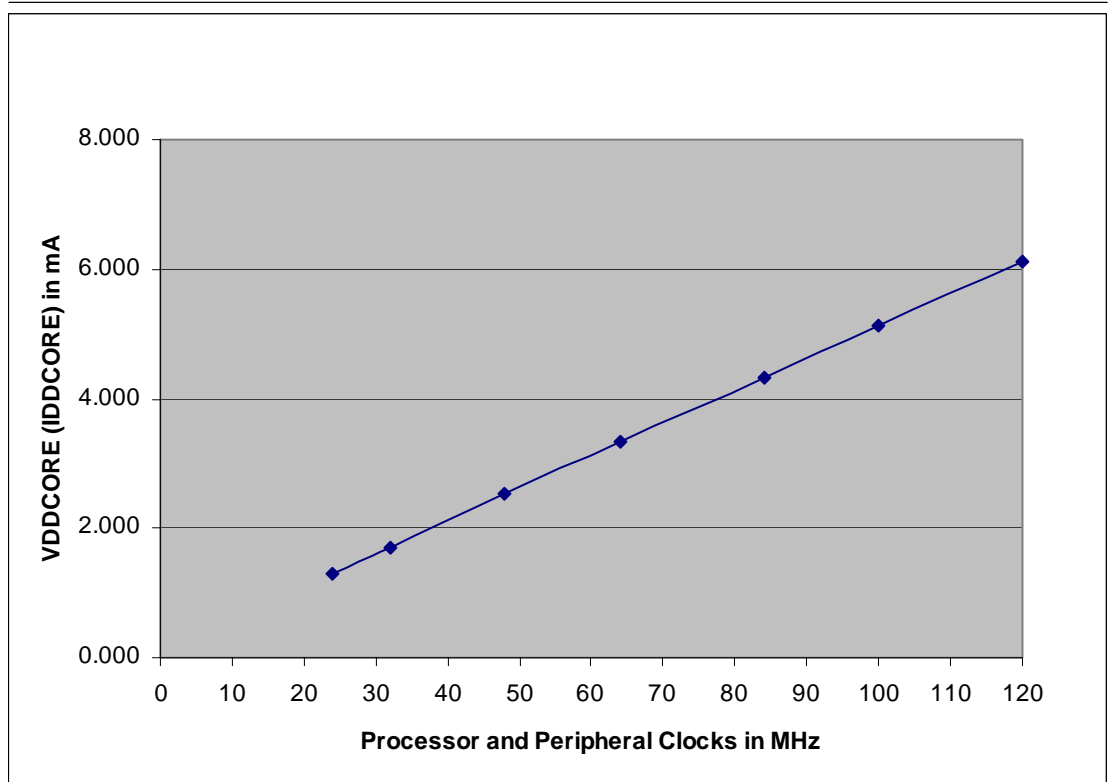
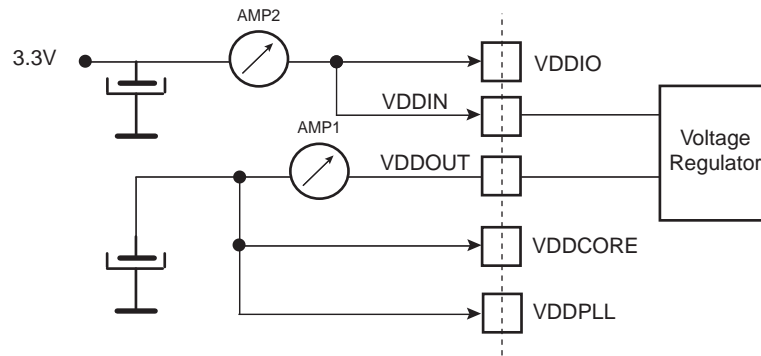

Table 42-11. Sleep mode Current consumption versus Master Clock (MCK) variation with PLLA

Core Clock/MCK (MHz)	VDDCORE Consumption (AMP1)	Total Consumption (AMP2)	Unit
120	8.1	9.9	mA
100	6.7	8.3	mA
84	5.7	7.1	mA
64	4.5	6.4	mA
48	3.4	4.8	mA
32	2.3	3.38	mA
24	1.8	3.31	mA

42.3.2.2 Wait Mode

Figure 42-7. Measurement Setup for Wait Mode



- Core Clock and Master Clock Stopped
- Current measurement as shown in the above figure
- All Peripheral clocks deactivated

Table 42-12 gives current consumption in typical conditions.

Table 42-12. Typical Current Consumption in Wait Mode

Conditions	VDDOUT Consumption (AMP1)	Total Consumption (AMP2)	Unit
See Figure 42-7 on page 1103 @25°C There is no activity on the I/Os of the device. With the Flash in Standby Mode	20.4	32.2	μA
See Figure 42-7 on page 1103 @25°C There is no activity on the I/Os of the device. With the Flash in Deep Power Down Mode	20.5	27.6	μA

42.3.3 Active Mode Power Consumption

The Active Mode configuration and measurements are defined as follows:

- VDDIO = VDDIN = 3.3V
- VDDCORE = 1.2V (Internal Voltage regulator used)
- T_A = 25°C
- Application Running from Flash Memory with 128-bit access Mode
- All Peripheral clocks are deactivated.
- Master Clock (MCK) running at various frequencies with PLLA or the fast RC oscillator.
- Current measurement on AMP1 (VDDCORE) and total current on AMP2

Figure 42-8. Active Mode Measurement Setup

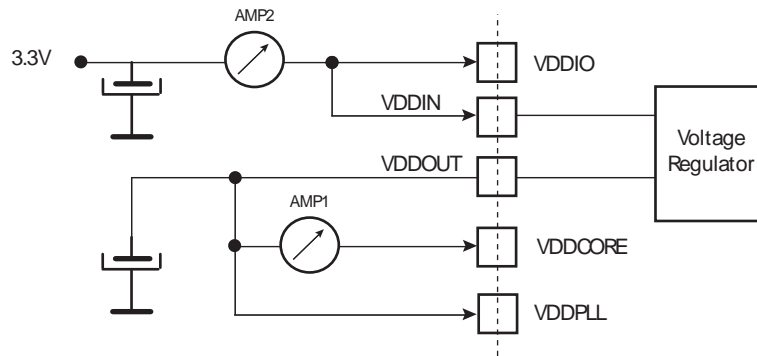

Tables below give Active Mode Current Consumption in typical conditions.

- VDDCORE at 1.2V
- Temperature = 25°C

Table 42-13. Active Power Consumption with VDDCORE @ 1.2V running from Flash Memory or SRAM

Core Clock (MHz)	CoreMark				Unit
	128-bit Flash access ⁽¹⁾		64-bit Flash access ⁽¹⁾		
	AMP1	AMP2	AMP1	AMP2	
120	24.9	28.8	18	21.4	mA
100	21.9	25.4	16.3	19.5	
84	18.5	21.4	13.8	16.6	
64	15.0	17.6	11.4	13.9	
48	11.9	14.3	9.6	11.8	
32	8.1	9.9	7.4	9.3	
24	6.0	7.7	5.8	7.5	
12	3.4	6.1	3.2	6.0	
8	2.3	4.5	2.2	4.5	
4	1.2	2.6	1.2	2.9	
2	0.7	1.9	0.7	2.0	
1	0.4	1.3	0.4	1.6	
0.5	0.3	1.1	0.3	1.3	

Note: 1. Flash Wait State (FWS) in EEFC_FMR adjusted versus Core Frequency

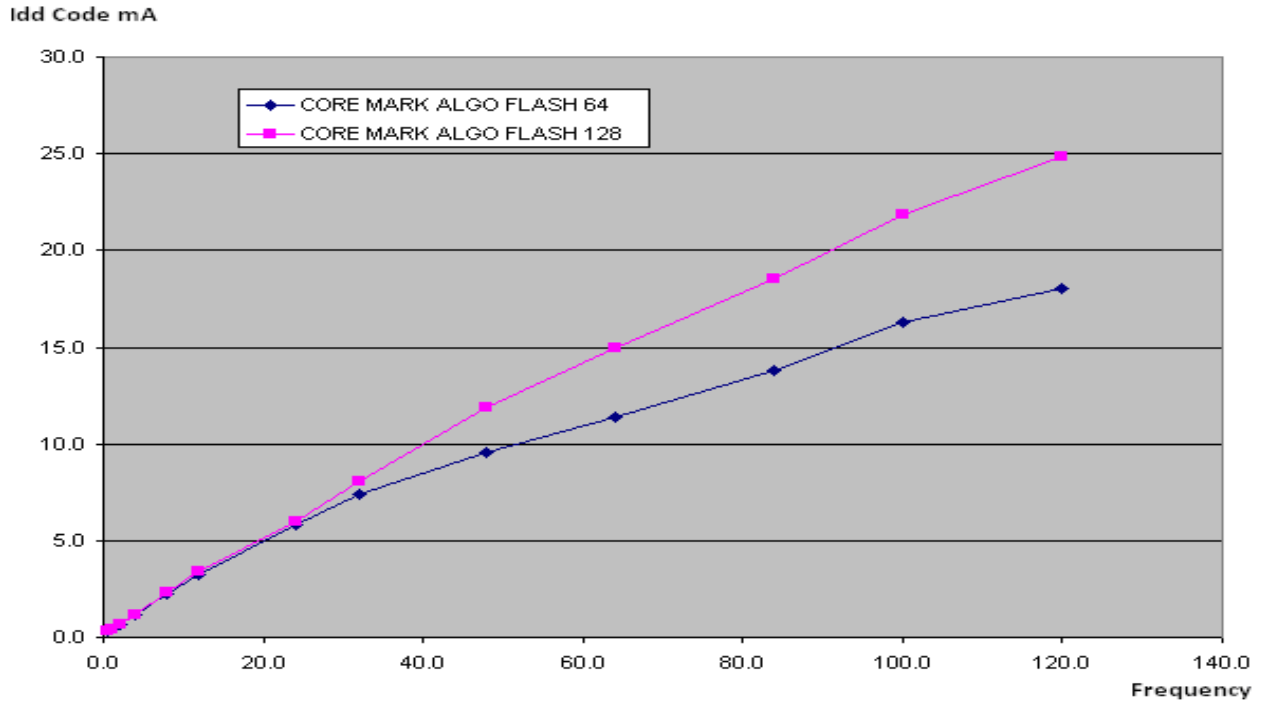

42.3.4 Peripheral Power Consumption in Active Mode

Table 42-14. Power Consumption on V_{DDCORE} ⁽¹⁾

Peripheral	Consumption (Typ)	Unit
PIO Controller A (PIOA)	5.6	μA/MHz
PIO Controller B (PIOB)	7.5	
PIO Controller C (PIOC)	5.9	
UART	3.8	
USART	7.7	
PWM	10.5	
TWI	5.8	
SPI	6.9	
Timer Counter (TCx)	4.7	
ADC	5.2	
DACC	5.2	
ACC	1.3	
HSMCI	7.7	
CRCCU	1.4	
SMC	3.6	
SSC	6.1	
UDP	5	

Note: 1. Note: $V_{DDIO} = 3.3V$, $V_{DDCORE} = 1.08V$, $T_A = 25^\circ C$

42.4 Oscillator Characteristics

42.4.1 32 kHz RC Oscillator Characteristics

Table 42-15. 32 kHz RC Oscillator Characteristics

Symbol	Parameter	Conditions	Min	Typ	Max	Unit
	RC Oscillator Frequency		20	32	44	kHz
	Frequency Supply Dependency		-3		3	%/V
	Frequency Temperature Dependency	Over temperature range (-40°C/ +85°C) versus 25°C	-7		7	%
Duty	Duty Cycle		45	50	55	%
T _{ON}	Startup Time				100	μs
I _{DDON}	Current Consumption	After Startup Time Temp. Range = -40°C to +125°C Typical Consumption at 2.2V supply and Temp = 25°C		540	860	nA

42.4.2 4/8/12 MHz RC Oscillators Characteristics

Table 42-16. 4/8/12 MHz RC Oscillators Characteristics

Symbol	Parameter	Conditions	Min	Typ	Max	Unit
F _{Range}	RC Oscillator Frequency Range	(1)	4		12	MHz
ACC ₄	4 MHz Total Accuracy	-40°C<Temp<+85°C 4 MHz output selected (1)(2)			±30	%
ACC ₈	8 MHz Total Accuracy	-40°C<Temp<+85°C 8 MHz output selected (1)(2)			±30	%
		-40°C<Temp<+85°C 8 MHz output selected (1)(3)			±5	
ACC ₁₂	12 MHz Total Accuracy	-40°C<Temp<+85°C 12 MHz output selected (1)(2)			±30	%
		-40°C<Temp<+85°C 12 MHz output selected (1)(3)			±5	
	Frequency deviation versus trimming code	8 MHz 12 MHz		47 64		kHz/trimming code
Duty	Duty Cycle		45	50	55	%
T _{ON}	Startup Time				10	μs
I _{DDON}	Active Current Consumption ⁽²⁾	4MHz		50	75	μA
		8MHz		65	95	
		12MHz		82	118	

- Notes: 1. Frequency range can be configured in the Supply Controller Registers
 2. Not trimmed from factory
 3. After Trimming from factory

The 4/8/12 MHz Fast RC oscillator is calibrated in production. This calibration can be read through the Get CALIB Bit command (see EEFC section) and the frequency can be trimmed by software through the PMC.

42.4.3 32.768 kHz Crystal Oscillator Characteristics

Table 42-17. 32.768 kHz Crystal Oscillator Characteristics

Symbol	Parameter	Conditions	Min	Typ	Max	Unit
F_{req}	Operating Frequency	Normal mode with crystal			32.768	KHz
	Supply Ripple Voltage (on VDDIO)	Rms value, 10 KHz to 10 MHz			30	mV
	Duty Cycle		40	50	60	%
	Startup Time	$R_s < 50K\Omega$ $C_{crystal} = 12.5pF$ $C_{crystal} = 6pF$			900 300	ms
		$R_s < 100K\Omega$ (1) $C_{crystal} = 12.5pF$ $C_{crystal} = 6pF$			1200 500	
I_{ddon}	Current consumption	$R_s < 50K\Omega$ $C_{crystal} = 12.5pF$ $C_{crystal} = 6pF$		550 380	1150 980	nA
		$R_s < 100K\Omega$ (1) $C_{crystal} = 12.5pF$ $C_{crystal} = 6pF$		820 530	1600 1350	
P_{ON}	Drive level				0.1	μW
R_f	Internal resistor	between XIN32 and XOUT32		10		$M\Omega$
C_{LEXT}	Maximum external capacitor on XIN32 and XOUT32				20	pF
C_{para}	Internal Parasitic Capacitance		0.6	0.7	0.8	pF

Note: 1. R_S is the series resistor.

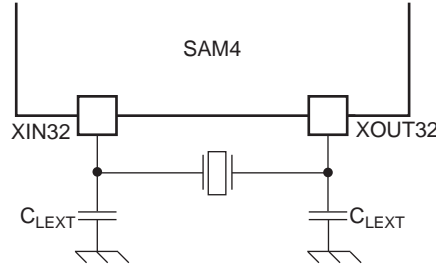

$$C_{LEXT} = 2X(C_{CRYSTAL} - C_{para} - C_{PCB}).$$

Where C_{PCB} is the capacitance of the printed circuit board (PCB) track layout from the crystal to the SAM4 pin.

42.4.4 32.768 kHz Crystal Characteristics

Table 42-18. Crystal Characteristics

Symbol	Parameter	Conditions	Min	Typ	Max	Unit
ESR	Equivalent Series Resistor (R_S)	Crystal @ 32.768 KHz		50	100	$K\Omega$
C_M	Motional capacitance	Crystal @ 32.768 KHz	0.6		3	fF
C_{SHUNT}	Shunt capacitance	Crystal @ 32.768 KHz	0.6		2	pF

42.4.5 3 to 20 MHz Crystal Oscillator Characteristics

Table 42-19. 3 to 20 MHz Crystal Oscillator Characteristics

Symbol	Parameter	Conditions	Min	Typ	Max	Unit
F_{req}	Operating Frequency	Normal mode with crystal	3	16	20	MHz
	Supply Ripple Voltage (on VDDPLL)	Rms value, 10 KHz to 10 MHz			30	mV
	Duty Cycle		40	50	60	%
T_{ON}	Startup Time	3 MHz, $C_{SHUNT} = 3pF$ 8 MHz, $C_{SHUNT} = 7pF$ 16 MHz, $C_{SHUNT} = 7pF$ with $C_m = 8fF$ 16 MHz, $C_{SHUNT} = 7pF$ with $C_m = 1.6fF$ 20 MHz, $C_{SHUNT} = 7pF$			14.5 4 1.4 2.5 1	ms
I_{DD_ON}	Current consumption (on VDDIO)	3 MHz ⁽²⁾ 8 MHz ⁽³⁾ 16 MHz ⁽⁴⁾ 20 MHz ⁽⁵⁾		230 300 390 450	350 400 470 560	μA
P_{ON}	Drive level	3 MHz 8 MHz 16 MHz, 20 MHz			15 30 50	μW
R_f	Internal resistor	between XIN and XOUT		0.5		$M\Omega$
C_{LEXT}	Maximum external capacitor on XIN and XOUT		12.5		17.5	pF
C_L	Internal Equivalent Load Capacitance	Integrated Load Capacitance (XIN and XOUT in series)	7.5	9.5	10.5	pF

- Notes:
- R_S is the series resistor
 - $R_s = 100-200$ Ohms; $C_s = 2.0 - 2.5pF$; $C_m = 2 - 1.5$ fF (typ, worst case) using 1 K Ω serial resistor on XOUT.
 - $R_s = 50-100$ Ohms; $C_s = 2.0 - 2.5pF$; $C_m = 4 - 3$ fF (typ, worst case).
 - $R_s = 25-50$ Ohms; $C_s = 2.5 - 3.0pF$; $C_m = 7 - 5$ fF (typ, worst case).
 - $R_s = 20-50$ Ohms; $C_s = 3.2 - 4.0pF$; $C_m = 10 - 8$ fF (typ, worst case).

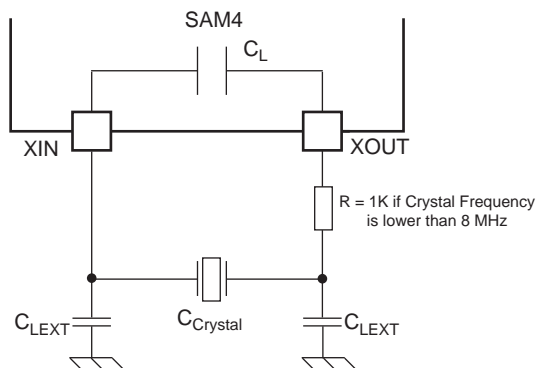

$$C_{LEXT} = 2x(C_{CRYSTAL} - C_L - C_{PCB}).$$

Where C_{PCB} is the capacitance of the printed circuit board (PCB) track layout from the crystal to the SAM4 pin.

42.4.6 3 to 20 MHz Crystal Characteristics

Table 42-20. Crystal Characteristics

Symbol	Parameter	Conditions	Min	Typ	Max	Unit
ESR	Equivalent Series Resistor (Rs)	Fundamental @ 3 MHz			200	Ω
		Fundamental @ 8 MHz			100	
		Fundamental @ 12 MHz			80	
		Fundamental @ 16 MHz			80	
		Fundamental @ 20 MHz			50	
C_M	Motional capacitance				8	fF
C_{SHUNT}	Shunt capacitance				7	pF

42.4.7 Crystal Oscillator Design Considerations Information

42.4.7.1 Choosing a Crystal

When choosing a crystal for the 32768 Hz Slow Clock Oscillator or for the 3-20 MHz Oscillator, several parameters must be taken into account. Important parameters between crystal and SAM4S specifications are as follows:

- Load Capacitance
 - $C_{crystal}$ is the equivalent capacitor value the oscillator must “show” to the crystal in order to oscillate at the target frequency. The crystal must be chosen according to the internal load capacitance (C_L) of the on-chip oscillator. Having a mismatch for the load capacitance will result in a frequency drift.
- Drive Level
 - Crystal drive level \geq Oscillator Drive Level. Having a crystal drive level number lower than the oscillator specification may damage the crystal.
- Equivalent Series Resistor (ESR)
 - Crystal ESR \leq Oscillator ESR Max. Having a crystal with ESR value higher than the oscillator may cause the oscillator to not start.
- Shunt Capacitance
 - Max. crystal Shunt capacitance \leq Oscillator Shunt Capacitance (C_{SHUNT}). Having a crystal with ESR value higher than the oscillator may cause the oscillator to not start.

42.4.7.2 Printed Circuit Board (PCB)

SAM4S Oscillators are low power oscillators requiring particular attention when designing PCB systems.

42.5 PLLA, PLLB Characteristics

Table 42-21. Supply Voltage Phase Lock Loop Characteristics

Symbol	Parameter	Conditions	Min	Typ	Max	Unit
VDDPLL	Supply Voltage Range		1.08	1.2	1.32	V
	Allowable Voltage Ripple	RMS Value 10 kHz to 10 MHz RMS Value > 10 MHz			20 10	mV

Table 42-22. PLLA and PLLB Characteristics

Symbol	Parameter	Conditions	Min	Typ	Max	Unit
F_{IN}	Input Frequency		3		32	MHz
F_{OUT}	Output Frequency		80		240	MHz
I_{PLL}	Current Consumption	Active mode @ 80 MHz @1.2V Active mode @ 96 MHz @1.2V Active mode @ 160 MHz @1.2V Active Mode @240 MHz @1.2V		0.94 1.2 2.1 3.34	1.2 1.5 2.5 4	mA
T_{START}	Settling Time			60	150	μ S

42.6 USB Transceiver Characteristics

42.6.1 Typical Connection

For typical connection please refer to the USB Device Section.

42.6.2 Electrical Characteristics

Table 42-23. Electrical Parameters

Symbol	Parameter	Conditions	Min	Typ	Max	Unit
Input Levels						
V_{IL}	Low Level				0.8	V
V_{IH}	High Level		2.0			V
V_{DI}	Differential Input Sensitivity	$ (D+) - (D-) $	0.2			V
V_{CM}	Differential Input Common Mode Range		0.8		2.5	V
C_{IN}	Transceiver capacitance	Capacitance to ground on each line			9.18	pF
I	Hi-Z State Data Line Leakage	$0V < V_{IN} < 3.3V$	-10		+10	μA
R_{EXT}	Recommended External USB Series Resistor	In series with each USB pin with $\pm 5\%$		27		Ω
Output Levels						
V_{OL}	Low Level Output	Measured with R_L of 1.425 k Ω tied to 3.6V	0.0		0.3	V
V_{OH}	High Level Output	Measured with R_L of 14.25 k Ω tied to GND	2.8		3.6	V
V_{CRS}	Output Signal Crossover Voltage	Measure conditions described in Figure 42-9 "USB Data Signal Rise and Fall Times"	1.3		2.0	V
Consumption						
I_{VDDIO}	Current Consumption	Transceiver enabled in input mode DDP = 1 and DDM = 0		105	200	μA
$I_{VDDCORE}$	Current Consumption			80	150	μA
Pull-up Resistor						
R_{PUI}	Bus Pull-up Resistor on Upstream Port (idle bus)		0.900		1.575	k Ω
R_{PUA}	Bus Pull-up Resistor on Upstream Port (upstream port receiving)		1.425		3.090	k Ω

42.6.3 Switching Characteristics

Table 42-24. In Full Speed

Symbol	Parameter	Conditions	Min	Typ	Max	Unit
t_{FR}	Transition Rise Time	$C_{LOAD} = 50 \text{ pF}$	4		20	ns
t_{FE}	Transition Fall Time	$C_{LOAD} = 50 \text{ pF}$	4		20	ns
t_{FRFM}	Rise/Fall time Matching		90		111.11	%

Figure 42-9. USB Data Signal Rise and Fall Times

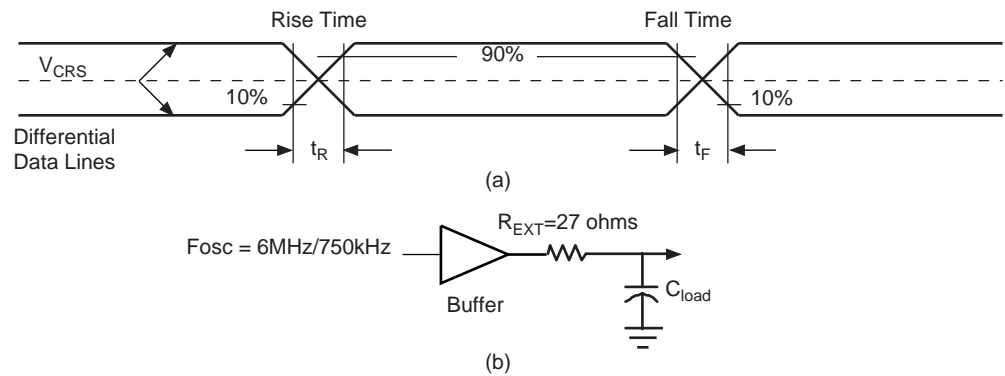

42.7 12-Bit ADC Characteristics

Table 42-25. Analog Power Supply Characteristics

Symbol	Parameter	Conditions	Min	Typ	Max	Units
V_{VDDIN}	ADC Analog Supply	12-bit or 10 bit resolution	2.4	3.0	3.6	V
	ADC Analog Supply	10 bit resolution	2.0		3.6	V
	Max. Voltage Ripple	rms value, 10 kHz to 20 MHz			20	mV
I_{VDDIN}	Current Consumption	Sleep Mode (Clock OFF)		2	4	μ A
		Fast Wake Up Mode (Standby CLK = 20MHz, IBCTL= 01)		2.4	3.5	mA
		Normal Mode (IBCTL= 01)		4.3	6	mA

Note: Use IBCTL = 00 for Sampling Frequency below 500 kHz and IBCTL = 01 between 500 kHz and 1MHz.

Table 42-26. Channel Conversion Time and ADC Clock

Symbol	Parameter	Conditions	Min	Typ	Max	Units
f_{ADC}	ADC Clock Frequency		1		20	MHz
t_{CP_ADC}	ADC Clock Period		50		1000	ns
f_s	Sampling Frequency				1	MHz
$t_{START-UP}$	ADC Startup time	From OFF Mode to Normal Mode: - Voltage Reference OFF - Analog Circuitry OFF	20	30	40	μ s
		From Standby Mode to Normal Mode: - Voltage Reference ON - Analog Circuitry OFF	4	8	12	
$t_{TRACKTIM}$	Track and Hold Time	See Section 42.7.1.1 "Track and Hold Time versus Source Output Impedance" for more details	160			ns
t_{CONV}	Conversion Time			20		T_{CP_ADC}
t_{cal}	Calibration Time				306	T_{CP_ADC}
t_{SETTLE}	Settling Time	Settling time to change offset and gain	200			ns

Table 42-27. External Voltage Reference Input

Parameter	Conditions	Min	Typ	Max	Units
ADVREF Input Voltage Range, 12-bit	$2.4V < V_{VDDIN} < 3.6V$	2.4	-	VDDIN	V
ADVREF Input Voltage Range, 10-bit	$2.0V < V_{VDDIN} < 3.6V$	2.0	-	VDDIN	V
ADVREF Input DC impedance		6	8	10	k Ω

42.7.1 Static performance characteristics

In the following tables, the LSB is relative to analog scale:

- Single Ended (ex: ADVREF=3.0V),
 - Gain = 1, LSB = (3.0V / 4096) = 732uV
 - Gain = 2, LSB = (1.5V / 4096) = 366uV
 - Gain = 4, LSB = (750mV / 4096) = 183uV
- Differential (ex: ADVREF=3.0V),
 - Gain = 0.5, LSB = (6.0V / 4096) = 1465uV
 - Gain = 1, LSB = (3.0V / 4096) = 732uV
 - Gain = 2, LSB = (1.5V / 4096) = 366uV

Table 42-28. INL, DNL, 12-bit mode, VDDIN 2.4V to 3.6V supply voltage conditions

Parameter	Conditions	Min	Typ	Max	Units
Resolution			12		Bit
Integral Non-linearity (INL)	Differential mode or single mode, Gain =xx	-4	±1	4	LSB
Differential Non-linearity (DNL)	Differential mode or single mode, Gain =xx	-2	±0.5	2	LSB

Table 42-29. Gain and Error offset, 12-bit Mode, VDDIN 2.4V to 3.6V supply voltage conditions

Parameter	Conditions	Min	Typ	Max	Units
Offset Error	Differential mode, Gain =xx	-24	±8	24	LSB
	Single Ended Gain = 1	-16	±5	16	
	Single Ended Gain = 2	-26	±8	26	
	Single Ended Gain = 4	-39	±13	39	
Gain Error, uncalibrated	Any gain and offset values	-45		45	
Gain Error, after calibration	Single Ended or Differential mode, Gain ≤1	-12		12	
	Single Ended or Differential mode, Gain = 2	-22		22	
	Single Ended or Differential mode Gain = 4	-28		28	

Table 42-30. Static Performance Characteristics -10 bits mode ⁽¹⁾

Parameter	Conditions	Min	Typ	Max	Units
Resolution			10		Bit
Integral Non-linearity (INL)			±0.5	±1	LSB
Differential Non-linearity (DNL)	No missing code		±0.5	±1	LSB
Offset Error		-10		10	LSB
Gain Error		-7		7	LSB

Note: 1. Single ended or differential mode, any gain values.

Table 42-31. Dynamic Performance Characteristics in Single ended and 12 bits mode ⁽¹⁾

Parameter	Conditions	Min	Typ	Max	Units
Signal to Noise Ratio - SNR		58	64	72	dB
Total Harmonic Distortion - THD		-84	-74	-66	dB
Signal to Noise and Distortion - SINAD		55	62	71	dB
Effective Number of Bits - ENOB		9	10.5	12	bits

Note: 1. ADC Clock (F_{ADC}) = 20 MHz, F_s =1 MHz, F_{in} = 127 kHz, $IBCTL$ = 01, FFT using 1024 points or more, Frequency band = [1 kHz, 500 kHz] – Nyquist conditions fulfilled.

Table 42-32. Dynamic Performance Characteristics in Differential and 12 bits mode ⁽¹⁾

Parameter	Conditions	Min	Typ	Max	Units
Signal to Noise Ratio - SNR		60	70	74	dB
Total Harmonic Distortion - THD		-90	-80	-72	dB
Signal to Noise and Distortion - SINAD		60	68	73	dB
Effective Number of Bits - ENOB		9.5	11	12	bits

Note: 1. ADC Clock (F_{ADC}) = 20 MHz, F_s = 1MHz, F_{in} = 127kHz, $IBCTL$ = 01, FFT using 1024 points or more, Frequency band = [1kHz, 500kHz] – Nyquist conditions fulfilled.

42.7.1.1 Track and Hold Time versus Source Output Impedance

The following figure gives a simplified acquisition path.

Figure 42-10. Simplified Acquisition Path

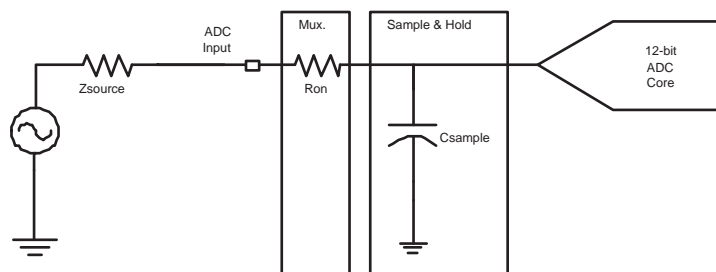

During the tracking phase the ADC needs to track the input signal during the tracking time shown below:

- 10-bit mode: $t_{TRACK} = 0.042 \times Z_{source} + 160$
- 12-bit mode: $t_{TRACK} = 0.054 \times Z_{source} + 205$

With t_{TRACK} expressed in ns and Z_{SOURCE} expressed in Ohms.

Two cases must be considered:

1. The calculated tracking time (t_{TRACK}) is lower than $15 t_{CP_ADC}$.

Set TRANSFER = 1 and TRACTIM = 0.

In this case, the allowed Z_{source} can be computed versus the ADC frequency with the hypothesis of $t_{TRACK} = 15 \times t_{CP_ADC}$:

Where $t_{CP_ADC} = 1/f_{ADC}$.

f_{ADC} = ADC clock (MHz)	Z_{SOURCE} (kOhms) for 12 bits	Z_{SOURCE} (kOhms) for 10 bits
20.00	10	14
16.00	14	19
10.67	22	30
8.00	31	41
6.40	40	52
5.33	48	63
4.57	57	74
4.00	66	85
3.56	74	97
3.20	83	108
2.91	92	119
2.67	100	130
2.46	109	141
2.29	118	152
2.13	126	164
2.00	135	175
1.00	274	353

2. The calculated tracking time (t_{TRACK}) is higher than $15 t_{CP_ADC}$.

Set TRANSFER = 1 and TRACTIM = 0.

In this case, a timer will trigger the ADC in order to set the correct sampling rate according to the Track time.

The maximum possible sampling frequency will be defined by t_{TRACK} in nano seconds, computed by the previous formula but with minus $15 \times t_{CP_ADC}$ and plus TRANSFER time.

- 10 bit mode: $1/f_S = t_{TRACK} - 15 \times t_{CP_ADC} + 5 t_{CP_ADC}$
- 12 bit mode: $1/f_S = t_{TRACK} - 15 \times t_{CP_ADC} + 5 t_{CP_ADC}$

Note: C_{sample} and R_{on} are taken into account in the formulas

Table 42-33. Analog Inputs

Parameter	Min	Typ	Max	Units
Input Voltage Range	0		V_{ADVREF}	
Input Leakage Current			± 0.5	μA
Input Capacitance			8	pF

Note: 1. Input Voltage range can be up to VDDIN without destruction or over-consumption.
If $VDDIO < V_{ADVREF}$ max input voltage is VDDIO.

42.8 12-Bit DAC Characteristics

Table 42-34. Analog Power Supply Characteristics

Symbol	Parameter	Conditions	Min	Typ	Max	Units
V_{VDDIN}	Analog Supply		2.4	3.0	3.6	V
	Max. Voltage Ripple	rms value, 10 kHz to 20 MHz			20	mV
I_{VDDIN}	Current Consumption	Sleep Mode (Clock OFF)			3	μA
		Fast Wake Up (Standby Mode, Clock on)		2	3	mA
		Normal Mode with 1 Output On (IBCTLDACCORE = 01, IBCTLCHx = 10)		4.3	5.6	mA
		Normal Mode with 2 Outputs On (IBCTLDACCORE = 01, IBCTLCHx = 10)		5	6.5	mA

Table 42-35. Channel Conversion Time and DAC Clock

Symbol	Parameter	Conditions	Min	Typ	Max	Units
F_{DAC}	Clock Frequency		1		50	MHz
T_{CP_DAC}	Clock Period				20	ns
F_S	Sampling Frequency				2	MHz
$T_{START-UP}$	Startup time	From Sleep Mode to Normal Mode: - Voltage Reference OFF - DAC Core OFF	20	30	40	μs
		From Fast Wake Up to Normal Mode: - Voltage Reference ON - DAC Core OFF	2.5	3.75	5	
T_{CONV}	Conversion Time				25	T_{CP_DAC}

External voltage reference for DAC is ADVREF. See the ADC voltage reference characteristics [Table 42-27 on page 1114](#)

Table 42-36. Static Performance Characteristics

Parameter	Conditions	Min	Typ	Max	Units
Resolution			12		Bit
Integral Non-linearity (INL)	$2.4V < V_{VDDIN} < 2.7V$	-6		+6	LSB
	$2.7V < V_{VDDIN} < 3.6V$	-2	±1	+2	
Differential Non-linearity (DNL)	$2.4V < V_{VDDIN} < 2.7V$	-2.5	±1	2.5	LSB
	$2.7V < V_{VDDIN} < 3.6V$				
Offset Error		-32	±8	32	LSB
Gain Error		-32	±2	32	LSB

Note: DAC Clock (F_{DAC}) = 5 MHz, F_s = 200 kHz, IBCTL = 01.

Table 42-37. Dynamic Performance Characteristics

Parameter	Conditions	Min	Typ	Max	Units
Signal to Noise Ratio - SNR	$2.4V < V_{VDDIN} < 2.7V$	50	62	70	dB
	$2.7V < V_{VDDIN} < 3.6V$	62	70	74	
Total Harmonic Distortion - THD	$2.4V < V_{VDDIN} < 2.7V$	-78	-64	-60	dB
	$2.7V < V_{VDDIN} < 3.6V$	-80	-74	-72	
Signal to Noise and Distortion - SINAD	$2.4V < V_{VDDIN} < 2.7V$	50	60	70	dB
	$2.7V < V_{VDDIN} < 3.6V$	62	68	73	
Effective Number of Bits - ENOB	$2.4V < V_{VDDIN} < 2.7V$	8	10	12	bits
	$2.7V < V_{VDDIN} < 3.6V$	10	11	12	

Note: DAC Clock (F_{DAC}) = 50 MHz, F_s = 2 MHz, F_{in} = 241kHz, IBCTL = 01, FFT using 1024 points or more, Frequency band = [10 kHz, 1MHz] – Nyquist conditions fulfilled.

Table 42-38. Analog Outputs

Parameter	Conditions	Min	Typ	Max	Units
Voltage Range		$(1/6) \times V_{ADVREF}$		$(5/6) \times V_{ADVREF}$	V
Slew Rate	Channel Output Current versus Slew Rate (IBCTL for DAC0 or DAC1, noted IBCTLCHx) $R_{LOAD} = 10k\Omega/0pF < C_{LOAD} < 50 pF$ IBCTLCHx = 00 IBCTLCHx = 01 IBCTLCHx = 10 IBCTLCHx = 11		2.7 5.3 8 10.7		V/ μ s
Output Channel Current Consumption	No resistive load IBCTLCHx = 00 IBCTLCHx = 01 IBCTLCHx = 10 IBCTLCHx = 11		0.23 0.45 0.67 0.89		mA
Settling Time	$R_{LOAD} = 10k\Omega/0pF < C_{LOAD} < 50pF,$			0.5	μ s
R_{LOAD}	Output Load Resistor	10			k Ω
C_{LOAD}	Output Load Capacitor		30	50	pF

42.9 Analog Comparator Characteristics

Analog Comparator Characteristics

Parameter	Conditions	Min	Typ	Max	Units
Voltage Range	The Analog Comparator is supplied by VDDIN	1.62	3.3	3.6	V
Input Voltage Range		GND + 0.2		VDDIN - 0.2	V
Input Offset Voltage				20	mV
Current Consumption	On VDDIN Low Power Option (ISEL = 0) High Speed Option (ISEL = 1)			25 170	μ A
Hysteresis	HYST = 0x01 or 0x10 HYST = 0x11		15 30	50 90	mV
Settling Time	Given for overdrive > 100 mV Low Power Option High Speed Option			1 0.1	μ s

42.10 Temperature Sensor

The temperature sensor is connected to Channel 15 of the ADC.

The temperature sensor provides an output voltage (V_T) that is proportional to absolute temperature (PTAT). The V_T output voltage linearly varies with a temperature slope $dV_T/dT = 4.72$ mV/°C.

The V_T voltage equals 1.44V at 27°C, with a ± 50 mV accuracy. The V_T slope versus temperature $dV_T/dT = 4.72$ mV/°C only shows a $\pm 8\%$ slight variation over process, mismatch and supply voltage.

The user needs to calibrate it (offset calibration) at ambient temperature in order to get rid of the V_T spread at ambient temperature ($\pm 15\%$).

Table 42-39. Temperature Sensor Characteristics

Symbol	Parameter	Conditions	Min	Typ	Max	Units
V_T	Output Voltage	$T^\circ = 27^\circ \text{C}$		1.44		V
ΔV_T	Output Voltage Accuracy	$T^\circ = 27^\circ \text{C}$	-50		+50	mV
dV_T/dT	Temperature Sensitivity (slope voltage versus temperature)			4.72		mV/°C
	Slope accuracy	Over temperature range [-40°C / +85°C]	-8		+8	%
	Temperature accuracy	After offset calibration Over temperature range [-40°C / +85°C]	-5		+5	°C
		After offset calibration Over temperature range [0°C / +80°C]	-3		+3	°C
$T_{\text{START-UP}}$	Startup Time	After TSON = 1		5	10	μs
I_{VDDCORE}	Current Consumption		50	70	80	μA

42.11 AC Characteristics

42.11.1 Master Clock Characteristics

Table 42-40. Master Clock Waveform Parameters

Symbol	Parameter	Conditions	Min	Max	Units
$1/(t_{\text{CPMCK}})$	Master Clock Frequency	VDDCORE @ 1.20V		120	MHz
$1/(t_{\text{CPMCK}})$	Master Clock Frequency	VDDCORE @ 1.08V		100	MHz

42.11.2 I/O Characteristics

Criteria used to define the maximum frequency of the I/Os:

- Output duty cycle (40%-60%)
- Minimum output swing: 100 mV to VDDIO - 100 mV
- Minimum output swing: 100 mV to VDDIO - 100 mV
- Addition of rising and falling time inferior to 75% of the period

Table 42-41. I/O Characteristics

Symbol	Parameter	Conditions		Min	Max	Units
FreqMax1	Pin Group 1 ⁽¹⁾ Maximum output frequency	10 pF	$V_{DDIO} = 1.62V$		70	MHz
		30 pF	$V_{DDIO} = 1.62V$		45	
PulseminH ₁	Pin Group 1 ⁽¹⁾ High Level Pulse Width	10 pF	$V_{DDIO} = 1.62V$	7.2		ns
		30 pF	$V_{DDIO} = 1.62V$	11		
PulseminL ₁	Pin Group 1 ⁽¹⁾ Low Level Pulse Width	10 pF	$V_{DDIO} = 1.62V$	7.2		ns
		30 pF	$V_{DDIO} = 1.62V$	11		
FreqMax2	Pin Group 2 ⁽²⁾ Maximum output frequency	10 pF	$V_{DDIO} = 1.62V$		46	MHz
		25 pF	$V_{DDIO} = 1.62V$		23	
PulseminH ₂	Pin Group 2 ⁽²⁾ High Level Pulse Width	10 pF	$V_{DDIO} = 1.62V$	11		ns
		25pF	$V_{DDIO} = 1.62V$	21.8		
PulseminL ₂	Pin Group 2 ⁽²⁾ Low Level Pulse Width	10 pF	$V_{DDIO} = 1.62V$	11		ns
		25 pF	$V_{DDIO} = 1.62V$	21.8		
FreqMax3	Pin Group 3 ⁽³⁾ Maximum output frequency	10 pF	$V_{DDIO} = 1.62V$		70	MHz
		25 pF	$V_{DDIO} = 1.62V$		35	
PulseminH ₃	Pin Group 3 ⁽³⁾ High Level Pulse Width	10 pF	$V_{DDIO} = 1.62V$	7.2		ns
		25 pF	$V_{DDIO} = 1.62V$	14.2		
PulseminL ₃	Pin Group 3 ⁽³⁾ Low Level Pulse Width	10 pF	$V_{DDIO} = 1.62V$	7.2		ns
		25 pF	$V_{DDIO} = 1.62V$	14.2		
FreqMax4	Pin Group 4 ⁽⁴⁾ Maximum output frequency	10 pF	$V_{DDIO} = 1.62V$		58	MHz
		25 pF	$V_{DDIO} = 1.62V$		29	
PulseminH ₄	Pin Group 4 ⁽⁴⁾ High Level Pulse Width	10 pF	$V_{DDIO} = 1.62V$	8.6		ns
		25pF	$V_{DDIO} = 1.62V$	17.2		
PulseminL ₄	Pin Group 4 ⁽⁴⁾ Low Level Pulse Width	10 pF	$V_{DDIO} = 1.62V$	8.6		ns
		25 pF	$V_{DDIO} = 1.62V$	17.2		
FreqMax5	Pin Group 5 ⁽⁵⁾ Maximum output frequency	25 pF	$V_{DDIO} = 1.62V$		25	MHz

- Notes:
1. Pin Group 1 = PA14, PA29
 2. Pin Group 2 = PA[4-11], PA[15-25], PA[30-31], PB[0-9], PB[12-14], PC[0-31]
 3. Pin Group 3 = PA[12-13], PA[26-28], PA[30-31]
 4. Pin Group 4 = PA[0-3]
 5. Pin Group 5 = PB[10-11]

42.11.3 SPI Characteristics

Figure 42-11. SPI Master Mode with (CPOL= NCPHA = 0) or (CPOL= NCPHA= 1)

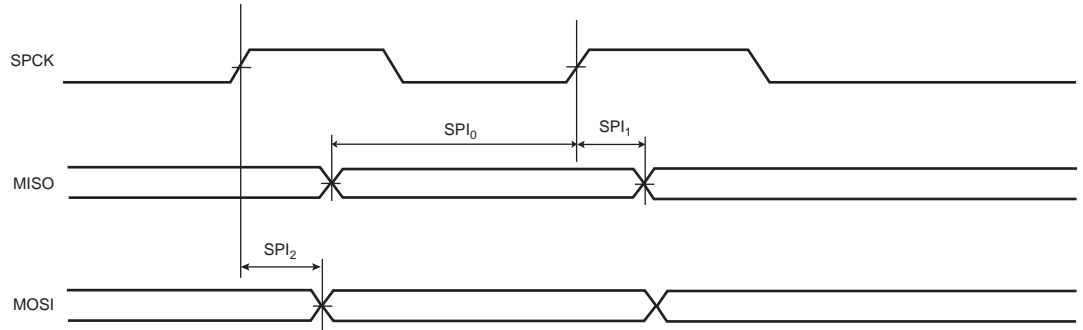

Figure 42-12. SPI Master Mode with (CPOL = 0 and NCPHA=1) or (CPOL=1 and NCPHA= 0)

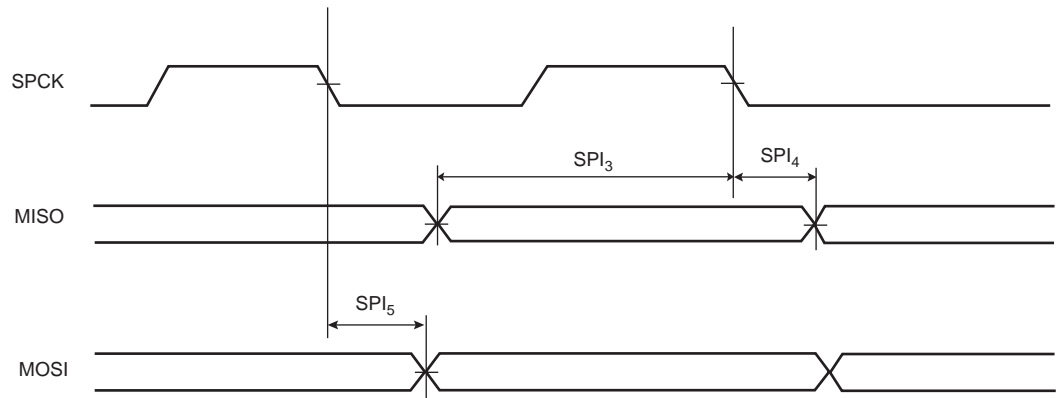

Figure 42-13. SPI Slave Mode with (CPOL=0 and NCPHA=1) or (CPOL=1 and NCPHA=0)

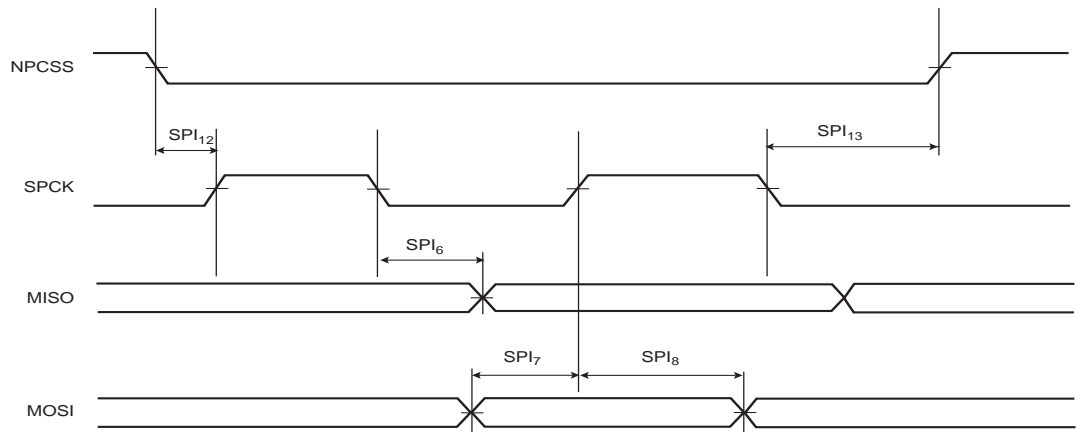
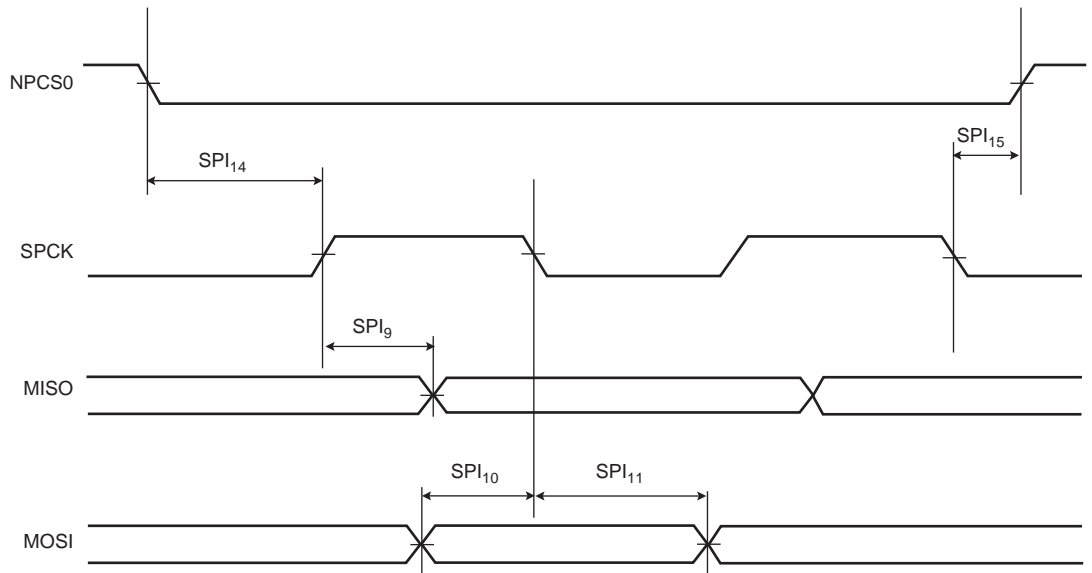

Figure 42-14. SPI Slave Mode with (CPOL = NCPHA = 0) or (CPOL= NCPHA= 1)



42.11.3.1 Maximum SPI Frequency

The following formulas give maximum SPI frequency in Master read and write modes and in Slave read and write modes.

Master Write Mode

The SPI is only sending data to a slave device such as an LCD, for example. The limit is given by SPI_2 (or SPI_5) timing. Since it gives a maximum frequency above the maximum pad speed (see Section 42.11.2 “I/O Characteristics”), the max SPI frequency is the one from the pad.

Master Read Mode

$$f_{SPCK}^{Max} = \frac{1}{SPI_0(\text{or } SPI_3) + T_{valid}}$$

T_{valid} is the slave time response to output data after detecting an SPCK edge. For Atmel SPI DataFlash (AT45DB642D), T_{valid} (or T_v) is 12 ns Max.

In the formula above, $F_{SPCK}^{Max} = 33.0 \text{ MHz @ } VDDIO = 3.3V$.

Slave Read Mode

In slave mode, SPCK is the input clock for the SPI. The max SPCK frequency is given by setup and hold timings SPI_7/SPI_8 (or SPI_{10}/SPI_{11}). Since this gives a frequency well above the pad limit, the limit in slave read mode is given by SPCK pad.

Slave Write Mode

$$f_{SPCK}^{Max} = \frac{1}{2x(SPI_{6max}(\text{or } SPI_{9max}) + T_{setup})}$$

For 3.3V I/O domain and SPI_6 , $F_{SPCK}^{Max} = 25 \text{ MHz}$. T_{setup} is the setup time from the master before sampling data.

42.11.3.2 SPI Timings

Table 42-42. SPI Timings

Symbol	Parameter	Conditions	Min	Max	Units
SPI ₀	MISO Setup time before SPCK rises (master)	3.3V domain ⁽¹⁾	11.3		ns
		1.8V domain ⁽²⁾	13.3		ns
SPI ₁	MISO Hold time after SPCK rises (master)	3.3V domain ⁽¹⁾	0		ns
		1.8V domain ⁽²⁾	0		ns
SPI ₂	SPCK rising to MOSI Delay (master)	3.3V domain ⁽¹⁾	-2.0	1.9	ns
		1.8V domain ⁽²⁾	-1.9	1.0	ns
SPI ₃	MISO Setup time before SPCK falls (master)	3.3V domain ⁽¹⁾	16.2		ns
		1.8V domain ⁽²⁾	18.4		ns
SPI ₄	MISO Hold time after SPCK falls (master)	3.3V domain ⁽¹⁾	0		ns
		1.8V domain ⁽²⁾	0		ns
SPI ₅	SPCK falling to MOSI Delay (master)	3.3V domain ⁽¹⁾	-7	-3.6	ns
		1.8V domain ⁽²⁾	-6.7	-4.2	ns
SPI ₆	SPCK falling to MISO Delay (slave)	3.3V domain ⁽¹⁾	3.4	11.1	ns
		1.8V domain ⁽²⁾	4.1	13.1	ns
SPI ₇	MOSI Setup time before SPCK rises (slave)	3.3V domain ⁽¹⁾	0		ns
		1.8V domain ⁽²⁾	0		ns
SPI ₈	MOSI Hold time after SPCK rises (slave)	3.3V domain ⁽¹⁾	1.3		ns
		1.8V domain ⁽²⁾	0.9		ns
SPI ₉	SPCK rising to MISO Delay (slave)	3.3V domain ⁽¹⁾	3.6	11.5	ns
		1.8V domain ⁽²⁾	4.1	12.9	ns
SPI ₁₀	MOSI Setup time before SPCK falls (slave)	3.3V domain ⁽¹⁾	0		ns
		1.8V domain ⁽²⁾	0		ns
SPI ₁₁	MOSI Hold time after SPCK falls (slave)	3.3V domain ⁽¹⁾	0.8		ns
		1.8V domain ⁽²⁾	0.9		ns
SPI ₁₂	NPCS setup to SPCK rising (slave)	3.3V domain ⁽¹⁾	3.3		ns
		1.8V domain ⁽²⁾	3.5		ns
SPI ₁₃	NPCS hold after SPCK falling (slave)	3.3V domain ⁽¹⁾	0		ns
		1.8V domain ⁽²⁾	0		ns
SPI ₁₄	NPCS setup to SPCK falling (slave)	3.3V domain ⁽¹⁾	4		ns
		1.8V domain ⁽²⁾	3.6		ns
SPI ₁₅	NPCS hold after SPCK falling (slave)	3.3V domain ⁽¹⁾	0		ns
		1.8V domain ⁽²⁾	0		ns

- Notes: 1. 3.3V domain: V_{VDDIO} from 2.85 V to 3.6V, maximum external capacitor = 40 pF.
 2. 1.8V domain: V_{VDDIO} from 1.65V to 1.95V, maximum external capacitor = 20 pF.

Note that in SPI master mode the SAM4S does not sample the data (MISO) on the opposite edge where data clocks out (MOSI) but the same edge is used as shown in [Figure 42-11](#) and [Figure 42-12](#).

42.11.4 HSMCI Timings

The High Speed MultiMedia Card Interface (HSMCI) supports the MultiMedia Card (MMC) Specification V4.3, the SD Memory Card Specification V2.0, the SDIO V2.0 specification and CE-ATA V1.1.

42.11.5 SSC Timings

Timings are given in the following domain:

1.8V domain: VDDIO from 1.65V to 1.95V, maximum external capacitor = 20 pF

3.3V domain: VDDIO from 2.85V to 3.6V, maximum external capacitor = 30 pF.

Figure 42-15. SSC Transmitter, TK and TF as output

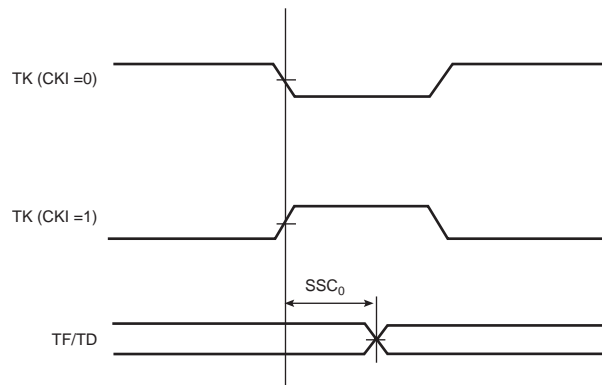

Figure 42-16. SSC Transmitter, TK as input and TF as output

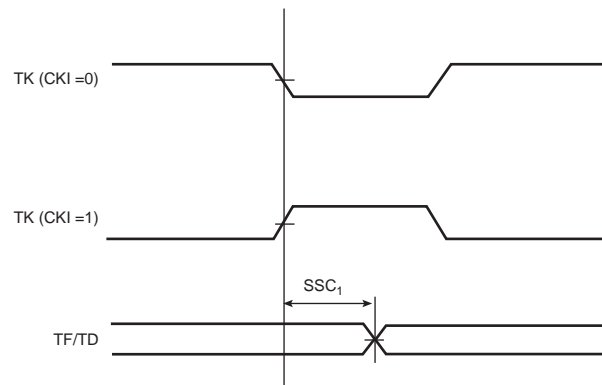

Figure 42-17. SSC Transmitter, TK as output and TF as input

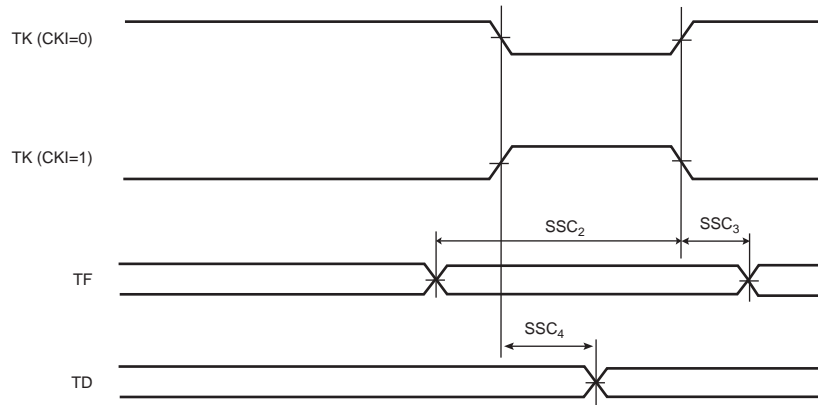

Figure 42-18. SSC Transmitter, TK and TF as input

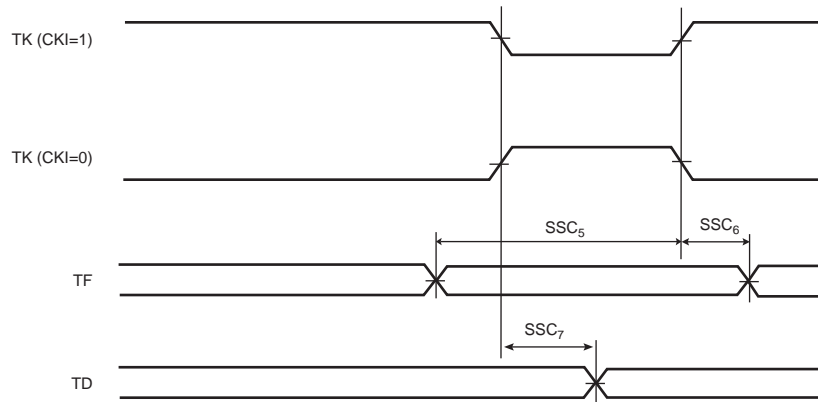

Figure 42-19. SSC Receiver RK and RF as input

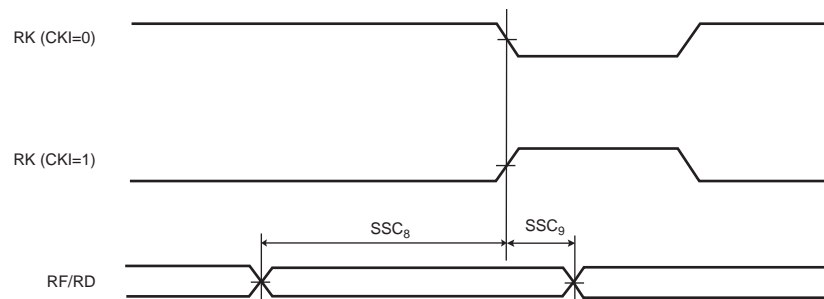

Figure 42-20. SSC Receiver, RK as input and RF as output

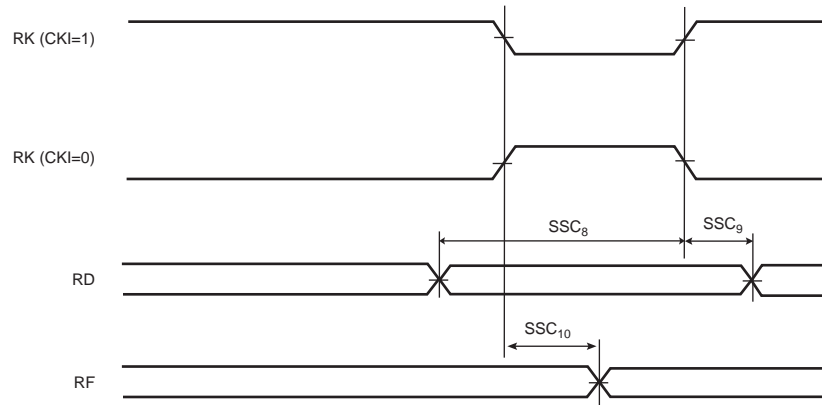

Figure 42-21. SSC Receiver, RK and RF as output

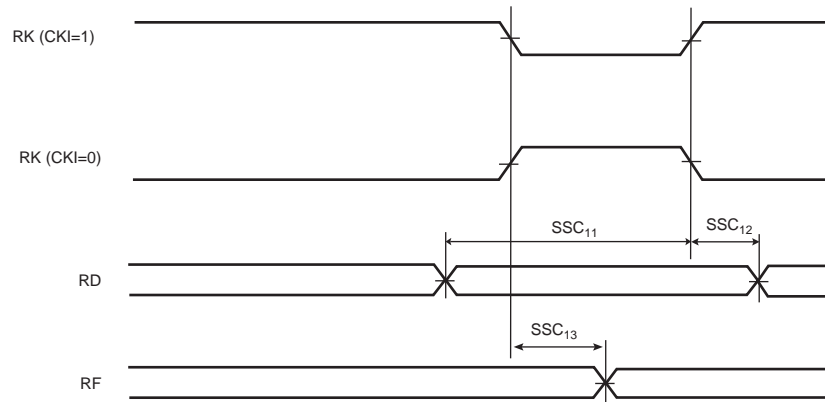
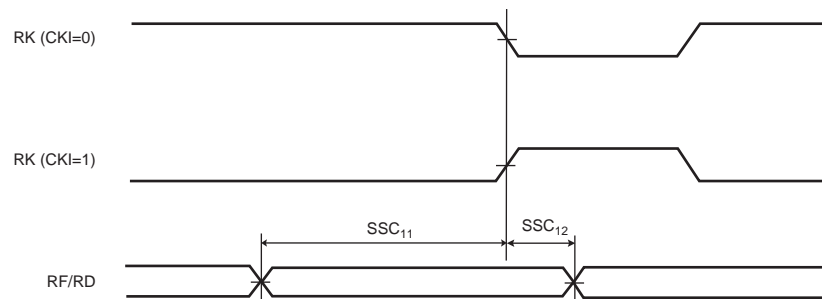

Figure 42-22. SSC Receiver, RK as output and RF as input



42.11.5.1 SSC Timings

Table 42-43. SSC Timings

Symbol	Parameter	Condition	Min	Max	Units
Transmitter					
SSC ₀	TK edge to TF/TD (TK output, TF output)	1.8v domain ⁽³⁾ 3.3v domain ⁽⁴⁾	-3 -2.6	5.4 5.0	ns
SSC ₁	TK edge to TF/TD (TK input, TF output)	1.8v domain ⁽³⁾ 3.3v domain ⁽⁴⁾	4.5 3.8	16.3 13.3	ns
SSC ₂	TF setup time before TK edge (TK output)	1.8v domain ⁽³⁾ 3.3v domain ⁽⁴⁾	14.8 12.0		ns
SSC ₃	TF hold time after TK edge (TK output)	1.8v domain ⁽³⁾ 3.3v domain ⁽⁴⁾	0		ns
SSC ₄ ⁽¹⁾	TK edge to TF/TD (TK output, TF input)	1.8v domain ⁽³⁾ 3.3v domain ⁽⁴⁾	2.6(+2*t _{CPMCK}) ⁽¹⁾⁽⁴⁾ 2.3(+2*t _{CPMCK}) ⁽¹⁾⁽⁴⁾	5.4(+2*t _{CPMCK}) ⁽¹⁾⁽⁴⁾ 5.0(+2*t _{CPMCK}) ⁽¹⁾⁽⁴⁾	ns
SSC ₅	TF setup time before TK edge (TK input)	1.8v domain ⁽³⁾ 3.3v domain ⁽⁴⁾	0		ns
SSC ₆	TF hold time after TK edge (TK input)	1.8v domain ⁽³⁾ 3.3v domain ⁽⁴⁾	t _{CPMCK}		ns
SSC ₇ ⁽¹⁾	TK edge to TF/TD (TK input, TF input)	1.8v domain ⁽³⁾ 3.3v domain ⁽⁴⁾	4.5(+3*t _{CPMCK}) ⁽¹⁾⁽⁴⁾ 3.8(+3*t _{CPMCK}) ⁽¹⁾⁽⁴⁾	16.3(+3*t _{CPMCK}) ⁽¹⁾⁽⁴⁾ 13.3(+3*t _{CPMCK}) ⁽¹⁾⁽⁴⁾	ns
Receiver					
SSC ₈	RF/RD setup time before RK edge (RK input)	1.8v domain ⁽³⁾ 3.3v domain ⁽⁴⁾	0		ns
SSC ₉	RF/RD hold time after RK edge (RK input)	1.8v domain ⁽³⁾ 3.3v domain ⁽⁴⁾	t _{CPMCK}		ns
SSC ₁₀	RK edge to RF (RK input)	1.8v domain ⁽³⁾ 3.3v domain ⁽⁴⁾	4.7 4	16.1 12.8	ns
SSC ₁₁	RF/RD setup time before RK edge (RK output)	1.8v domain ⁽³⁾ 3.3v domain ⁽⁴⁾	15.8 - t _{CPMCK} 12.5 - t _{CPMCK}		ns
SSC ₁₂	RF/RD hold time after RK edge (RK output)	1.8v domain ⁽³⁾ 3.3v domain ⁽⁴⁾	t _{CPMCK} - 4.3 t _{CPMCK} - 3.6		ns
SSC ₁₃	RK edge to RF (RK output)	1.8v domain ⁽³⁾ 3.3v domain ⁽⁴⁾	-3 -2.6	4.3 3.8	ns

- Notes:
1. Timings SSC4 and SSC7 depend on the start condition. When STTDLY = 0 (Receive start delay) and START = 4, or 5 or 7 (Receive Start Selection), two Periods of the MCK must be added to timings.
 2. For output signals (TF, TD, RF), Min and Max access times are defined. The Min access time is the time between the TK (or RK) edge and the signal change. The Max access timing is the time between the TK edge and the signal stabilization. [Figure 42-23](#) illustrates Min and Max accesses for SSC0. The same applies for SSC1, SSC4, and SSC7, SSC10 and SSC13.
 3. 1.8V domain: V_{VDDIO} from 1.65V to 1.95V, maximum external capacitor = 20 pF.
 4. 3.3V domain: V_{VDDIO} from 2.85V to 3.6V, maximum external capacitor = 30 pF.

Figure 42-23. Min and Max Access Time of Output Signals

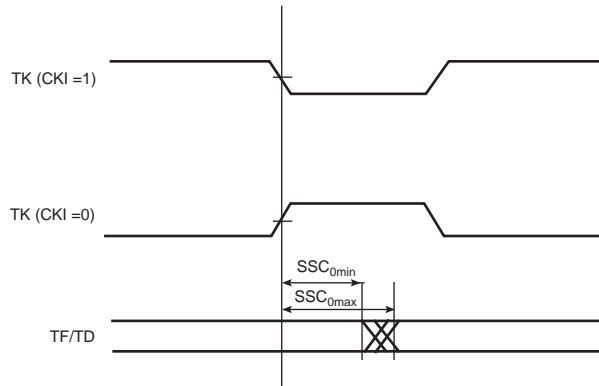

42.11.6 SMC Timings

Timings are given in the following domain:

1.8V domain: VDDIO from 1.65V to 1.95V, maximum external capacitor = 30 pF

3.3V domain: VDDIO from 2.85V to 3.6V, maximum external capacitor = 50 pF.

Timings are given assuming a capacitance load on data, control and address pads:

In the following tables t_{CPMCK} is MCK period. Timing extraction

42.11.6.1 Read Timings

Table 42-44. SMC Read Signals - NRD Controlled (READ_MODE = 1)

Symbol	Parameter	Min		Max		Units
		1.8V ⁽²⁾	3.3V ⁽³⁾	1.8V ⁽²⁾	3.3V ⁽³⁾	
NO HOLD SETTINGS (nrd hold = 0)						
SMC ₁	Data Setup before NRD High	19.9	17.9			ns
SMC ₂	Data Hold after NRD High	0	0			ns
HOLD SETTINGS (nrd hold ≠ 0)						
SMC ₃	Data Setup before NRD High	16.0	14.0			ns
SMC ₄	Data Hold after NRD High	0	0			ns
HOLD or NO HOLD SETTINGS (nrd hold ≠ 0, nrd hold = 0)						
SMC ₅	A0 - A22 Valid before NRD High	(nrd setup + nrd pulse) * $t_{CPMCK} - 6.5$	(nrd setup + nrd pulse) * $t_{CPMCK} - 6.3$			ns
SMC ₆	NCS low before NRD High	(nrd setup + nrd pulse - ncs rd setup) * $t_{CPMCK} - 4.6$	(nrd setup + nrd pulse - ncs rd setup) * $t_{CPMCK} - 5.1$			ns
SMC ₇	NRD Pulse Width	nrd pulse * $t_{CPMCK} - 7.2$	nrd pulse * $t_{CPMCK} - 6.2$			ns

Table 42-45. SMC Read Signals - NCS Controlled (READ_MODE= 0)

Symbol	Parameter	Min		Max		Units
		1.8V ⁽²⁾	3.3V ⁽³⁾	1.8V ⁽²⁾	3.3V ⁽³⁾	
	VDDIO supply	1.8V⁽²⁾	3.3V⁽³⁾	1.8V⁽²⁾	3.3V⁽³⁾	
NO HOLD SETTINGS (ncs rd hold = 0)						
SMC ₈	Data Setup before NCS High	20.7	18.4			ns
SMC ₉	Data Hold after NCS High	0	0			ns
HOLD SETTINGS (ncs rd hold ≠ 0)						
SMC ₁₀	Data Setup before NCS High	16.8	14.5			ns
SMC ₁₁	Data Hold after NCS High	0	0			ns
HOLD or NO HOLD SETTINGS (ncs rd hold ≠ 0, ncs rd hold = 0)						
SMC ₁₂	A0 - A22 valid before NCS High	(ncs rd setup + ncs rd pulse) * t _{CPMCK} - 6.5	(ncs rd setup + ncs rd pulse) * t _{CPMCK} - 6.3			ns
SMC ₁₃	NRD low before NCS High	(ncs rd setup + ncs rd pulse - nrd setup) * t _{CPMCK} - 5.6	(ncs rd setup + ncs rd pulse - nrd setup) * t _{CPMCK} - 5.4			ns
SMC ₁₄	NCS Pulse Width	ncs rd pulse length * t _{CPMCK} - 7.7	ncs rd pulse length * t _{CPMCK} - 6.7			ns

42.11.6.2 Write Timings

Table 42-46. SMC Write Signals - NWE Controlled (WRITE_MODE = 1)

Symbol	Parameter	Min		Max		Units
		1.8V ⁽²⁾	3.3V ⁽³⁾	1.8V ⁽²⁾	3.3V ⁽³⁾	
HOLD or NO HOLD SETTINGS (nwe hold ≠ 0, nwe hold = 0)						
SMC ₁₅	Data Out Valid before NWE High	nwe pulse * t _{CPMCK} - 6.9	nwe pulse * t _{CPMCK} - 6.7			ns
SMC ₁₆	NWE Pulse Width	nwe pulse * t _{CPMCK} - 7.3	nwe pulse * t _{CPMCK} - 6.3			ns
SMC ₁₇	A0 - A22 valid before NWE low	nwe setup * t _{CPMCK} - 7.2	nwe setup * t _{CPMCK} - 7.0			ns
SMC ₁₈	NCS low before NWE high	(nwe setup - ncs rd setup + nwe pulse) * t _{CPMCK} - 7.1	(nwe setup - ncs rd setup + nwe pulse) * t _{CPMCK} - 6.8			ns



Table 42-46. SMC Write Signals - NWE Controlled (WRITE_MODE = 1) (Continued)

Symbol	Parameter	Min		Max		Units
		1.8V ⁽²⁾	3.3V ⁽³⁾	1.8V ⁽²⁾	3.3V ⁽³⁾	
HOLD SETTINGS (nwe hold ≠ 0)						
SMC ₁₉	NWE High to Data OUT, NBS0/A0 NBS1, NBS2/A1, NBS3, A2 - A25 change	nwe hold * t _{CPMCK} - 8.8	nwe hold * t _{CPMCK} - 6.9			ns
SMC ₂₀	NWE High to NCS Inactive ⁽¹⁾	(nwe hold - ncs wr hold)* t _{CPMCK} - 5.2	(nwe hold - ncs wr hold)* t _{CPMCK} - 5.0			ns
NO HOLD SETTINGS (nwe hold = 0)						
SMC ₂₁	NWE High to Data OUT, NBS0/A0 NBS1, NBS2/A1, NBS3, A2 - A25, NCS change ⁽¹⁾	3.0	2.8			ns

Table 42-47. SMC Write NCS Controlled (WRITE_MODE = 0)

Symbol	Parameter	Min		Max		Units
		1.8V ⁽²⁾	3.3V ⁽³⁾	1.8V ⁽²⁾	3.3V ⁽³⁾	
SMC ₂₂	Data Out Valid before NCS High	ncs wr pulse * t _{CPMCK} - 6.3	ncs wr pulse * t _{CPMCK} - 6.2			ns
SMC ₂₃	NCS Pulse Width	ncs wr pulse * t _{CPMCK} - 7.7	ncs wr pulse * t _{CPMCK} - 6.7			ns
SMC ₂₄	A0 - A22 valid before NCS low	ncs wr setup * t _{CPMCK} - 6.5	ncs wr setup * t _{CPMCK} - 6.3			ns
SMC ₂₅	NWE low before NCS high	(ncs wr setup - nwe setup + ncs pulse)* t _{CPMCK} - 5.1	(ncs wr setup - nwe setup + ncs pulse)* t _{CPMCK} - 4.9			ns
SMC ₂₆	NCS High to Data Out, A0 - A25, change	ncs wr hold * t _{CPMCK} - 10.2	ncs wr hold * t _{CPMCK} - 8.4			ns
SMC ₂₇	NCS High to NWE Inactive	(ncs wr hold - nwe hold)* t _{CPMCK} - 7.4	(ncs wr hold - nwe hold)* t _{CPMCK} - 7.1			ns

- Notes: 1. Hold length = total cycle duration - setup duration - pulse duration. "hold length" is for "ncs wr hold length" or "NWE hold length".
 2. 1.8V domain: VDDIO from 1.65 V to 1.95V, maximum external capacitor = 30pF
 3. 3.3V domain: VDDIO from 2.85V to 3.6V, maximum external capacitor = 50pF.

Figure 42-24. SMC Timings - NCS Controlled Read and Write

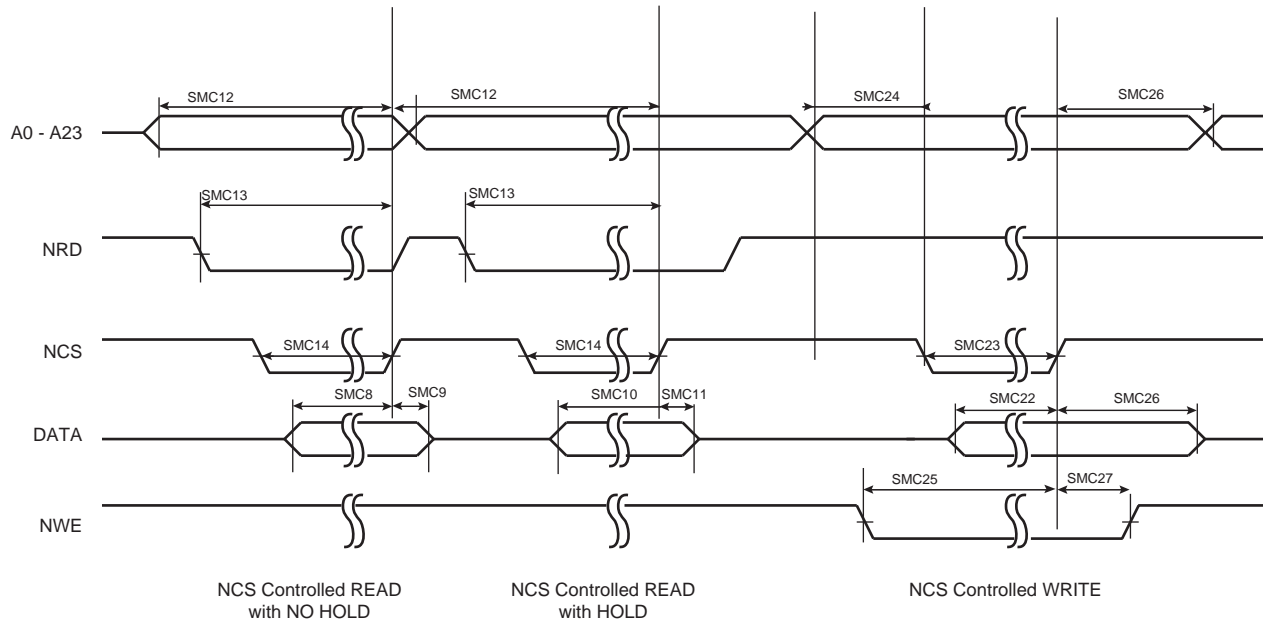
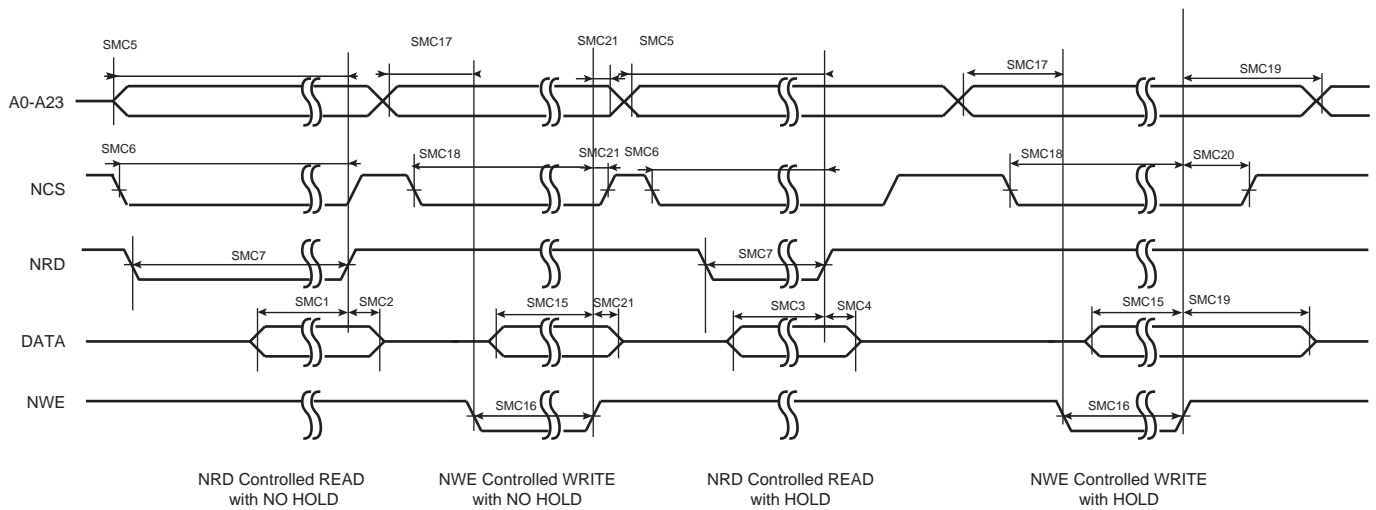

Figure 42-25. SMC Timings - NRD Controlled Read and NWE Controlled Write



42.11.7 USART in SPI Mode Timings

Timings are given in the following domain:

1.8V domain: VDDIO from 1.65V to 1.95V, maximum external capacitor = 20 pF

3.3V domain: VDDIO from 2.85V to 3.6V, maximum external capacitor = 40 pF.

Figure 42-26. USART SPI Master Mode

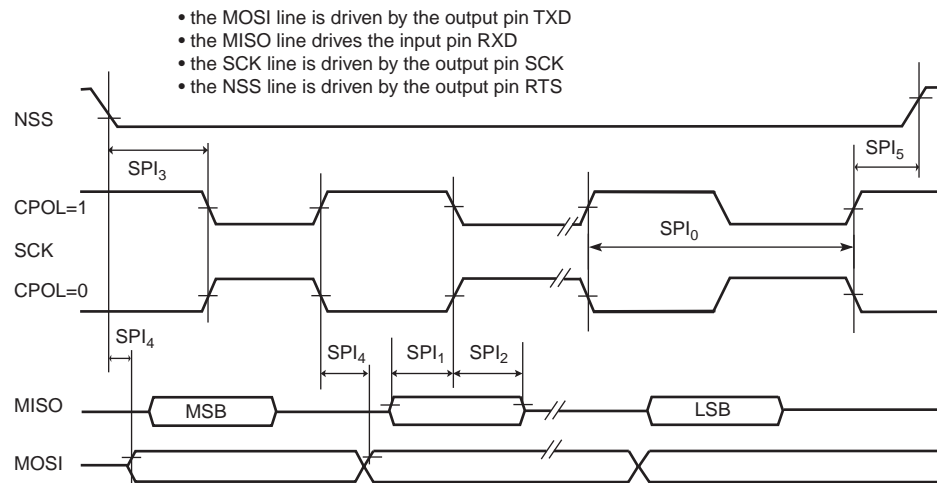

Figure 42-27. USART SPI Slave Mode: (Mode 1 or 2)

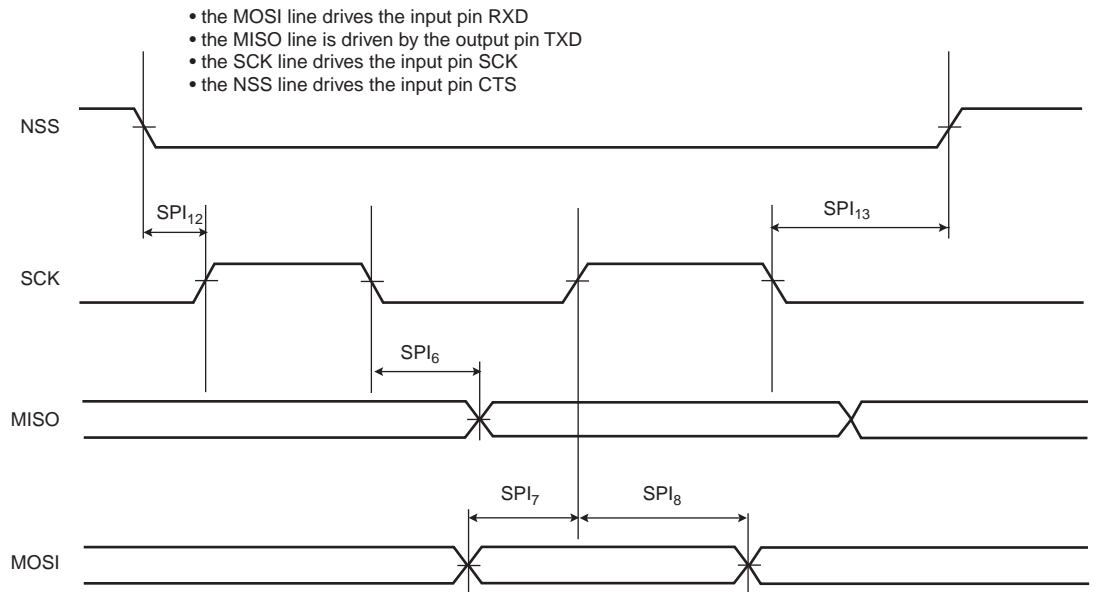
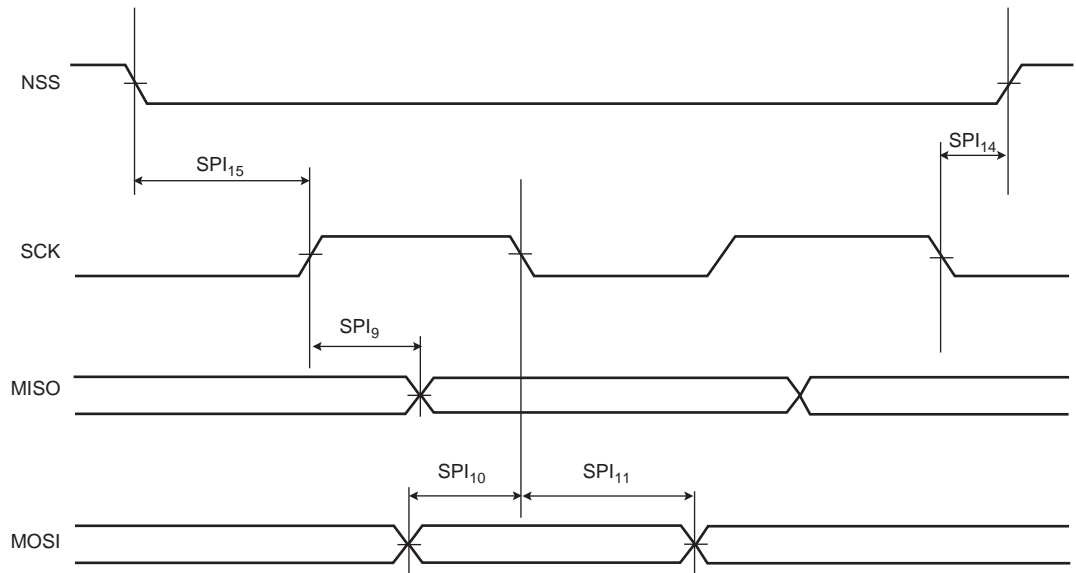

Figure 42-28. USART SPI Slave mode: (Mode 0 or 3)



42.11.7.1 USART SPI Timings

Table 42-48. USART SPI Timings

Symbol	Parameter	Conditions	Min	Max	Units
Master Mode					
SPI ₀	SCK Period	1.8v domain 3.3v domain	MCK/6		ns
SPI ₁	Input Data Setup Time	1.8v domain 3.3v domain	0.5 * MCK + 0.8 0.5 * MCK + 1.0		ns
SPI ₂	Input Data Hold Time	1.8v domain 3.3v domain	1.5 * MCK + 0.3 1.5 * MCK + 0.1		ns
SPI ₃	Chip Select Active to Serial Clock	1.8v domain 3.3v domain	1.5 * SPCK - 1.5 1.5 * SPCK - 2.1		ns
SPI ₄	Output Data Setup Time	1.8v domain 3.3v domain	- 7.9 - 7.2	9.9 10.7	ns
SPI ₅	Serial Clock to Chip Select Inactive	1.8v domain 3.3v domain	1 * SPCK - 4.1 1 * SPCK - 4.8		ns
Slave Mode					
SPI ₆	SCK falling to MISO	1.8V domain 3.3V domain	4.7 4	17.3 15.2	ns
SPI ₇	MOSI Setup time before SCK rises	1.8V domain 3.3V domain	2 * MCK + 0.7 2 * MCK		ns
SPI ₈	MOSI Hold time after SCK rises	1.8v domain 3.3v domain	0 0.1		ns

Table 42-48. USART SPI Timings (Continued)

Symbol	Parameter	Conditions	Min	Max	Units
SPI ₉	SCK rising to MISO	1.8v domain	4.7	17.1	ns
		3.3v domain	4.1	15.5	
SPI ₁₀	MOSI Setup time before SCK falls	1.8v domain	2 * MCK + 0.7		ns
		3.3v domain	2 * MCK + 0.6		
SPI ₁₁	MOSI Hold time after SCK falls	1.8v domain	0.2		ns
		3.3v domain	0.1		
SPI ₁₂	NPCS0 setup to SCK rising	1.8v domain	2,5 * MCK + 0.5		ns
		3.3v domain	2,5 * MCK		
SPI ₁₃	NPCS0 hold after SCK falling	1.8v domain	1,5 * MCK + 0.2		ns
		3.3v domain	1,5 * MCK		
SPI ₁₄	NPCS0 setup to SCK falling	1.8v domain	2,5 * MCK + 0.5		ns
		3.3v domain	2,5 * MCK + 0.3		
SPI ₁₅	NPCS0 hold after SCK rising	1.8v domain	1,5 * MCK		ns
		3.3v domain	1,5 * MCK		

- Notes: 1. 1.8V domain: VDDIO from 1.65V to 1.95V, maximum external capacitor = 20 pF
 2. 3.3V domain: VDDIO from 2.85V to 3.6V, maximum external capacitor = 40 pF.

42.11.8 Two-wire Serial Interface Characteristics

Table 50 describes the requirements for devices connected to the Two-wire Serial Bus. For timing symbols refer to [Figure 42-29](#).

Table 42-49. Two-wire Serial Bus Requirements

Symbol	Parameter	Condition	Min	Max	Units
V _{IL}	Input Low-voltage		-0.3	0.3 V _{VDDIO}	V
V _{IH}	Input High-voltage		0.7×V _{VDDIO}	V _{CC} + 0.3	V
V _{HYS}	Hysteresis of Schmitt Trigger Inputs		0.150	–	V
V _{OL}	Output Low-voltage	3 mA sink current	-	0.4	V
t _R	Rise Time for both TWD and TWCK		20 + 0.1C _b ⁽¹⁾⁽²⁾	300	ns
t _{OF}	Output Fall Time from V _{IHmin} to V _{ILmax}	10 pF < C _b < 400 pF Figure 42-29	20 + 0.1C _b ⁽¹⁾⁽²⁾	250	ns
C _i ⁽¹⁾	Capacitance for each I/O Pin		–	10	pF
f _{TWCK}	TWCK Clock Frequency		0	400	kHz
R _p	Value of Pull-up resistor	f _{TWCK} ≤ 100 kHz	$\frac{V_{VDDIO} - 0,4V}{3mA}$	$\frac{1000ns}{C_b}$	Ω
		f _{TWCK} > 100 kHz	$\frac{V_{VDDIO} - 0,4V}{3mA}$	$\frac{300ns}{C_b}$	Ω
t _{LOW}	Low Period of the TWCK clock	f _{TWCK} ≤ 100 kHz	(3)	–	μs
		f _{TWCK} > 100 kHz	(3)	–	μs
t _{HIGH}	High period of the TWCK clock	f _{TWCK} ≤ 100 kHz	(4)	–	μs
		f _{TWCK} > 100 kHz	(4)	–	μs
t _{HD;STA}	Hold Time (repeated) START Condition	f _{TWCK} ≤ 100 kHz	t _{HIGH}	–	μs
		f _{TWCK} > 100 kHz	t _{HIGH}	–	μs
t _{SU;STA}	Set-up time for a repeated START condition	f _{TWCK} ≤ 100 kHz	t _{HIGH}	–	μs
		f _{TWCK} > 100 kHz	t _{HIGH}	–	μs
t _{HD;DAT}	Data hold time	f _{TWCK} ≤ 100 kHz	0	3 × T _{CP_MCK} ⁽⁵⁾	μs
		f _{TWCK} > 100 kHz	0	3 × T _{CP_MCK} ⁽⁵⁾	μs
t _{SU;DAT}	Data setup time	f _{TWCK} ≤ 100 kHz	$t_{LOW} - 3 \times t_{CP_MCK}^{(5)}$	–	ns
		f _{TWCK} > 100 kHz	$t_{LOW} - 3 \times t_{CP_MCK}^{(5)}$	–	ns
t _{SU;STO}	Setup time for STOP condition	f _{TWCK} ≤ 100 kHz	t _{HIGH}	–	μs
		f _{TWCK} > 100 kHz	t _{HIGH}	–	μs
t _{HD;STA}	Hold Time (repeated) START Condition	f _{TWCK} ≤ 100 kHz	t _{HIGH}	–	μs
		f _{TWCK} > 100 kHz	t _{HIGH}	–	μs

Notes: 1. Required only for f_{TWCK} > 100 kHz.

2. C_B = capacitance of one bus line in pF. Per I2C Standard, C_B Max = 400pF

3. The TWCK low Period is defined as follows: $T_{low} = ((CLDIV \times 2^{CKDIV}) + 4) \times T_{MCK}$

4. The TWCK high period is defined as follows: $T_{high} = ((CHDIV \times 2^{CKDIV}) + 4) \times T_{MCK}$

5. t_{CP_MCK} = MCK Bus Period.



Figure 42-29. Two-wire Serial Bus Timing

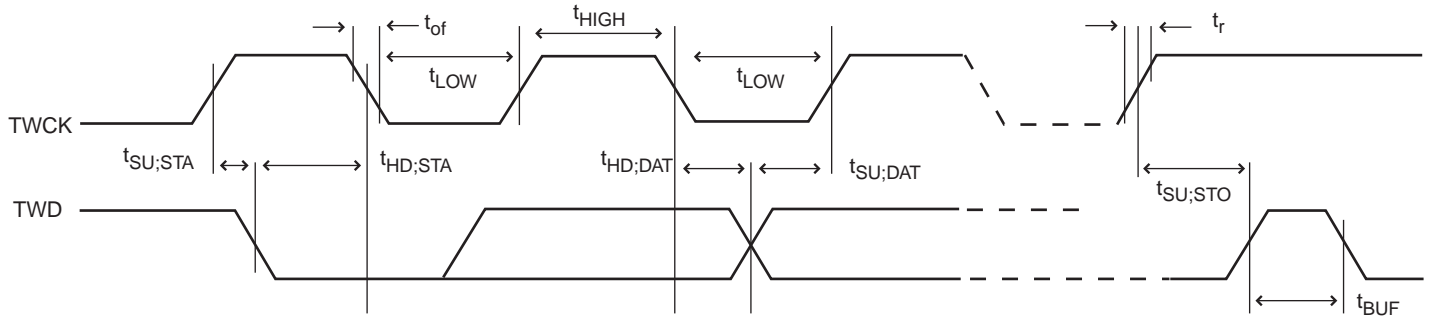

42.11.9 Embedded Flash Characteristics

The maximum operating frequency is given in tables 42-50 to 42-53 below but is limited by the Embedded Flash access time when the processor is fetching code out of it. The tables 42-50 to 42-53 below give the device maximum operating frequency depending on the field FWS of the MC_FMR register. This field defines the number of wait states required to access the Embedded Flash Memory.

The embedded flash is fully tested during production test, the flash contents are not set to a known state prior to shipment. Therefore, the flash contents should be erased prior to programming an application.

Table 42-50. Embedded Flash Wait State VDDCORE set at 1.08V and VDDIO 1.62V to 3.6V @85C

FWS	Read Operations	Maximum Operating Frequency (MHz)
0	1 cycle	16
1	2 cycles	33
2	3 cycles	50
3	4 cycles	67
4	5 cycles	84
5	6 cycles	100

Table 42-51. Embedded Flash Wait State VDDCORE set at 1.08V and VDDIO 2.7V to 3.6V @85C

FWS	Read Operations	Maximum Operating Frequency (MHz)
0	1 cycle	20
1	2 cycles	40
2	3 cycles	60
3	4 cycles	80
4	5 cycles	100

Table 42-52. Embedded Flash Wait State VDDCORE set at 1.2V and VDDIO 1.62V to 3.6V @ 85C

FWS	Read Operations	Maximum Operating Frequency (MHz)
0	1 cycle	17
1	2 cycles	34
2	3 cycles	52
3	4 cycles	69
4	5 cycles	87
5	6 cycles	104
6	7 cycles	121

Table 42-53. Embedded Flash Wait State VDDCORE set at 1.20V and VDDIO 2.7V to 3.6V @ 85C

FWS	Read Operations	Maximum Operating Frequency (MHz)
0	1 cycle	21
1	2 cycles	42
2	3 cycles	63
3	4 cycles	84
4	5 cycles	105
5	6 cycles	123

Table 42-54. AC Flash Characteristics

Parameter	Conditions	Min	Typ	Max	Units
Program Cycle Time	Erase page mode		10	50	ms
	Erase block mode (by 4Kbytes)		50	200	ms
	Erase sector mode		400	950	ms
Full Chip Erase	1 MBytes 512 KBytes		9 5.5	18 11	s
Data Retention	Not Powered or Powered		20		Years
Endurance	Write/Erase cycles per page, block or sector @ 25°C Write/Erase cycles per page, block or sector @ 85°C	10K	100K		cycles

43. SAM4S Mechanical Characteristics

Figure 43-1. 100-lead LQFP Package Mechanical Drawing

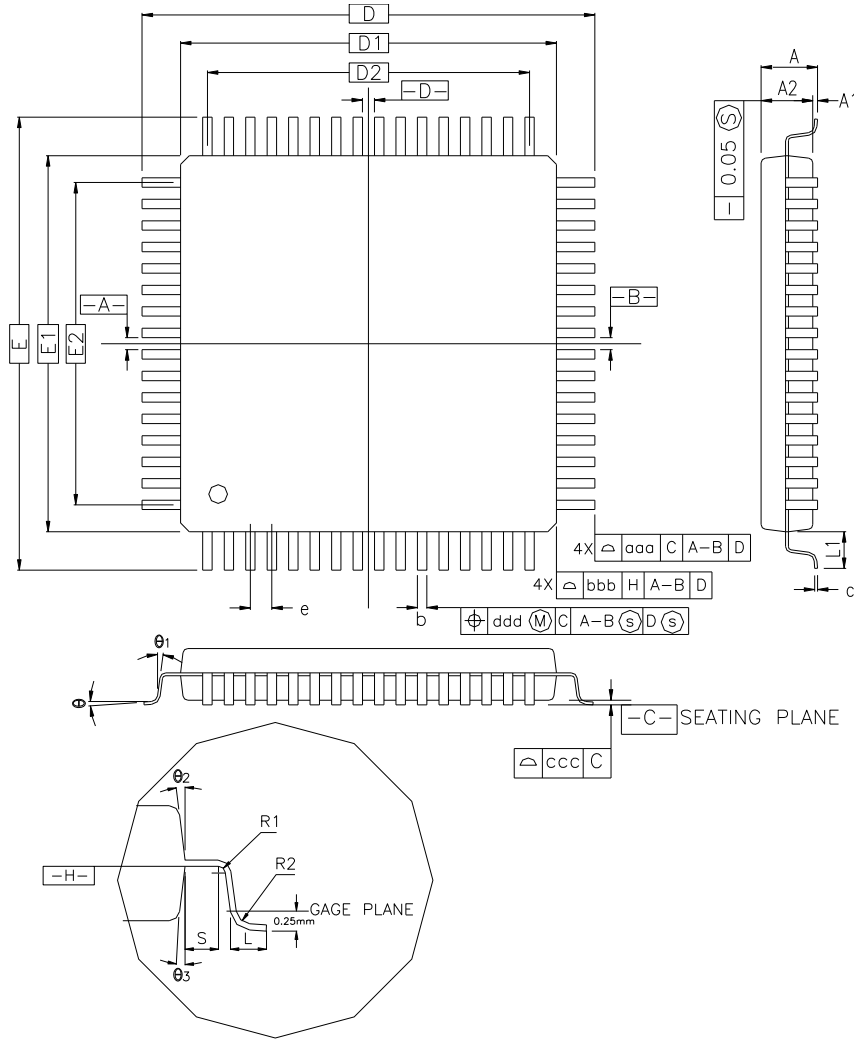

COTROL DIMENSIONS ARE IN MILLIMETERS.

SYMBOL	MILLIMETER			INCH		
	MIN.	NOM.	MAX.	MIN.	NOM.	MAX.
A	—	—	1.60	—	—	0.063
A1	0.05	—	0.15	0.002	—	0.006
A2	1.35	1.40	1.45	0.053	0.055	0.057
D	16.00 BSC.			0.630 BSC.		
D1	14.00 BSC.			0.551 BSC.		
E	16.00 BSC.			0.630 BSC.		
E1	14.00 BSC.			0.551 BSC.		
R2	0.08	—	0.20	0.003	—	0.008
R1	0.08	—	—	0.003	—	—
θ	0°	3.5°	7°	0°	3.5°	7°
θ_1	0°	—	—	0°	—	—
θ_2	11°	12°	13°	11°	12°	13°
θ_3	11°	12°	13°	11°	12°	13°
c	0.09	—	0.20	0.004	—	0.008
L	0.45	0.60	0.75	0.018	0.024	0.030
L ₁	1.00 REF			0.039 REF		
S	0.20	—	—	0.008	—	—
b	0.17	0.20	0.27	0.007	0.008	0.011
e	0.50 BSC.			0.020 BSC.		
D2	12.00			0.472		
E2	12.00			0.472		
TOLERANCES OF FORM AND POSITION						
aaa	0.20			0.008		
bbb	0.20			0.008		
ccc	0.08			0.003		
ddd	0.08			0.003		

Note : 1. This drawing is for general information only. Refer to JEDEC Drawing MS-026 for additional information.

Table 43-1. Device and LQFP Package Maximum Weight

SAM4S	800	mg
-------	-----	----

Table 43-2. Package Reference

JEDEC Drawing Reference	MS-026
JESD97 Classification	e3

Table 43-3. LQFP Package Characteristics

Moisture Sensitivity Level	3
----------------------------	---

This package respects the recommendations of the NEMI User Group.

Figure 43-2. 100-ball TFBGA Package Drawing

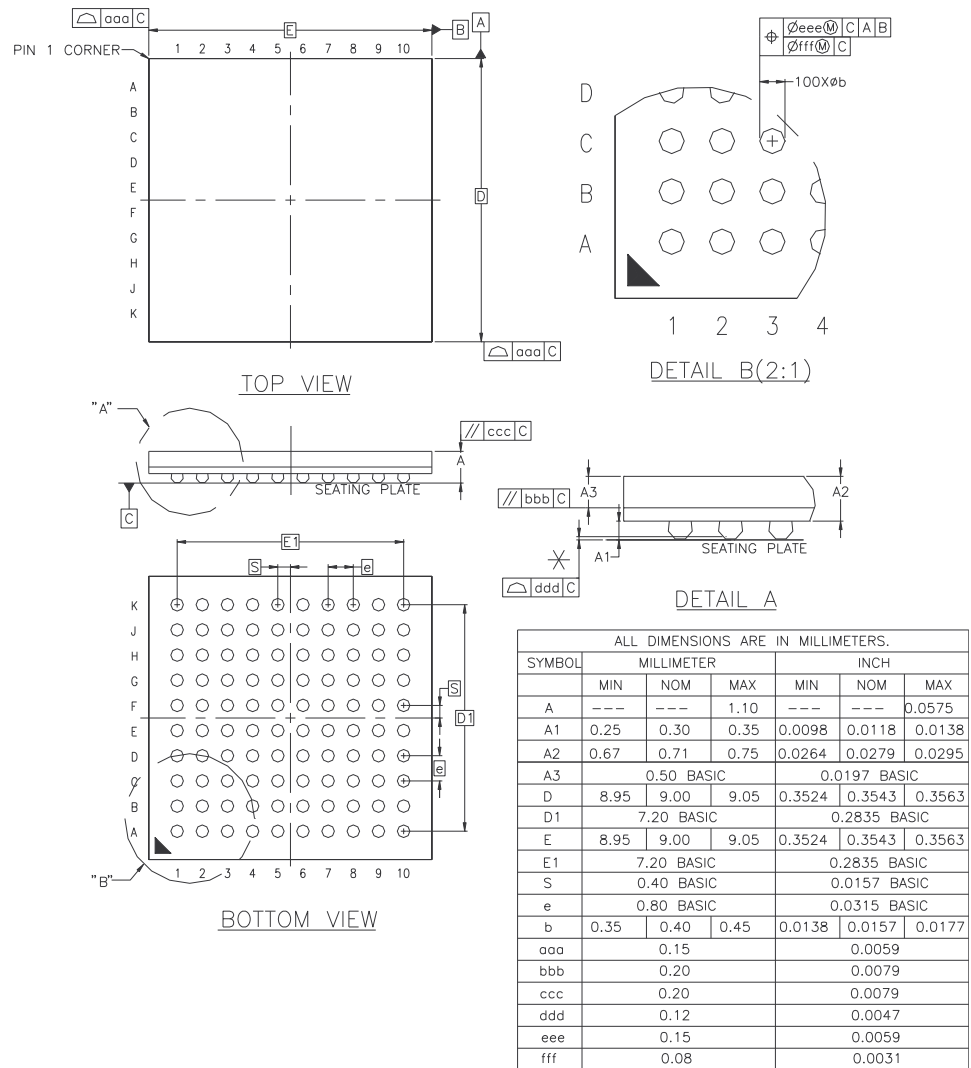

Table 43-4. Soldering Information (Substrate Level)

Ball Land	TBD
Soldering Mask Opening	TBD

Table 43-5. Device Maximum Weight

TBD	mg
-----	----

Table 43-6. 100-ball Package Characteristics

Moisture Sensitivity Level	3
----------------------------	---

Table 43-7. Package Reference

JEDEC Drawing Reference	TBD
JESD97 Classification	e1

Figure 43-3. 100-ball VFBGA Package Drawing

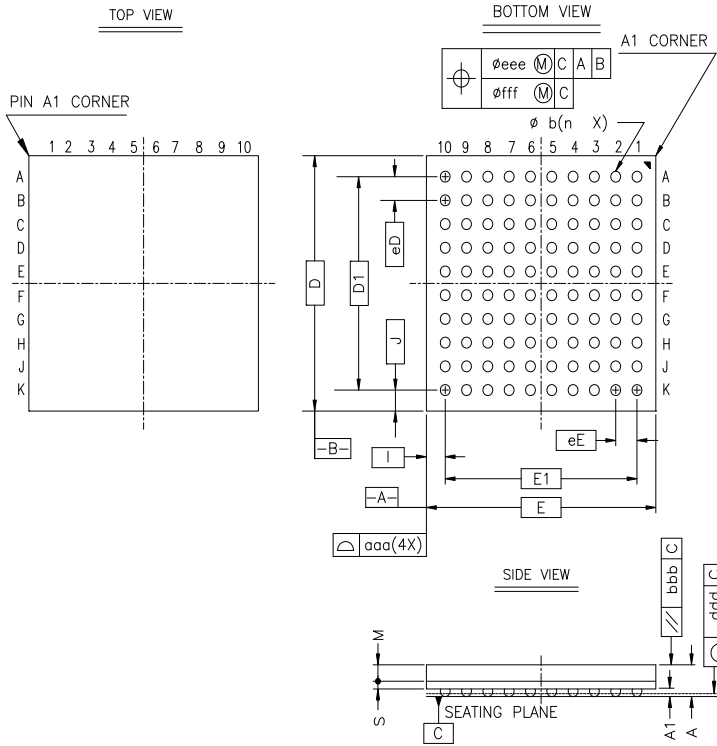

	Symbol	Common Dimensions
Package :		VFBGA
Body Size:	X	E 7.000±0.100
	Y	D 7.000±0.100
Ball Pitch :	X	eE 0.650
	Y	eD 0.650
Total Thickness :	A	1.000 MAX
Mold Thickness :	M	0.450 Ref.
Substrate Thickness :	s	0.210 Ref.
Ball Diameter :		0.300
Stand Off :	A1	0.160 ~ 0.260
Ball Width :	b	0.270 ~ 0.370
Package Edge Tolerance :	aaa	0.100
Mold Flatness :	bbb	0.100
Coplanarity:	ddd	0.080
Ball Offset (Package) :	eee	0.150
Ball Offset (Ball) :	fff	0.080
Ball Count :	n	100
Edge Ball Center to Center :	X	E1 5.850
	Y	D1 5.850
Corner Ball Center to Package Edge:	X	I 0.575
	Y	J 0.575

Figure 43-4. 64-lead LQFP Package Drawing

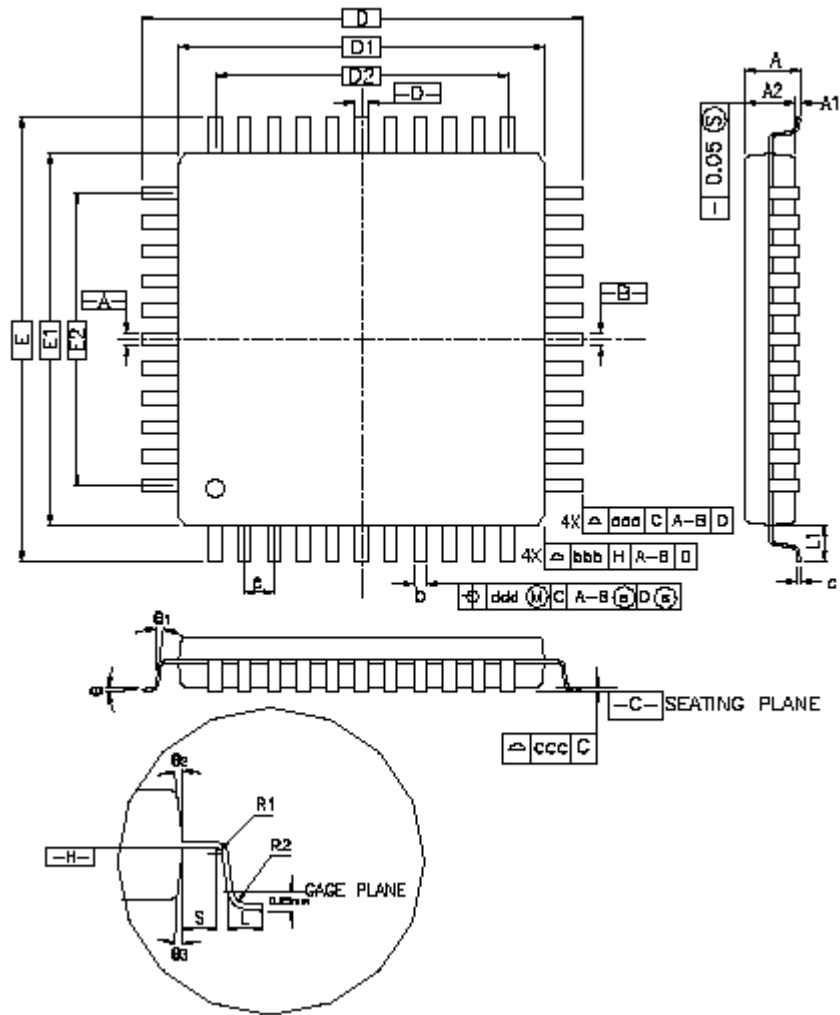



Table 43-8. 64-lead LQFP Package Dimensions (in mm)

Symbol	Millimeter			Inch		
	Min	Nom	Max	Min	Nom	Max
A	–	–	1.60	–	–	0.063
A1	0.05	–	0.15	0.002	–	0.006
A2	1.35	1.40	1.45	0.053	0.055	0.057
D	12.00 BSC			0.472 BSC		
D1	10.00 BSC			0.383 BSC		
E	12.00 BSC			0.472 BSC		
E1	10.00 BSC			0.383 BSC		
R2	0.08	–	0.20	0.003	–	0.008
R1	0.08	–	–	0.003	–	–
θ	0°	3.5°	7°	0°	3.5°	7°
$\theta 1$	0°	–	–	0°	–	–
$\theta 2$	11°	12°	13°	11°	12°	13°
$\theta 3$	11°	12°	13°	11°	12°	13°
c	0.09	–	0.20	0.004	–	0.008
L	0.45	0.60	0.75	0.018	0.024	0.030
L1	1.00 REF			0.039 REF		
S	0.20	–	–	0.008	–	–
b	0.17	0.20	0.27	0.007	0.008	0.011
e	0.50 BSC.			0.020 BSC.		
D2	7.50			0.285		
E2	7.50			0.285		
Tolerances of Form and Position						
aaa	0.20			0.008		
bbb	0.20			0.008		
ccc	0.08			0.003		
ddd	0.08			0.003		

Table 43-9. Device and LQFP Package Maximum Weight

SAM4S	750	mg
-------	-----	----

Table 43-10. LQFP Package Reference

JEDEC Drawing Reference	MS-026
JESD97 Classification	e3

Table 43-11. LQFP and QFN Package Characteristics

Moisture Sensitivity Level	3
----------------------------	---

This package respects the recommendations of the NEMI User Group.

Figure 43-5. 64-lead QFN Package Drawing

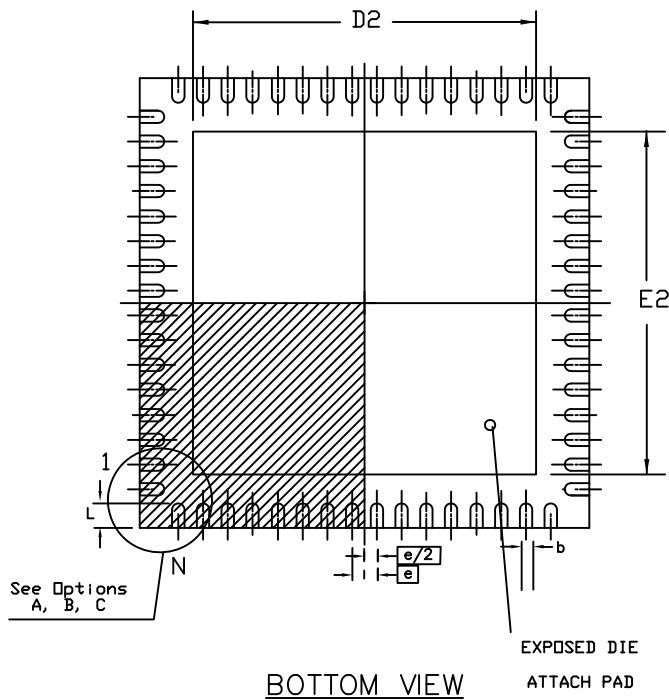
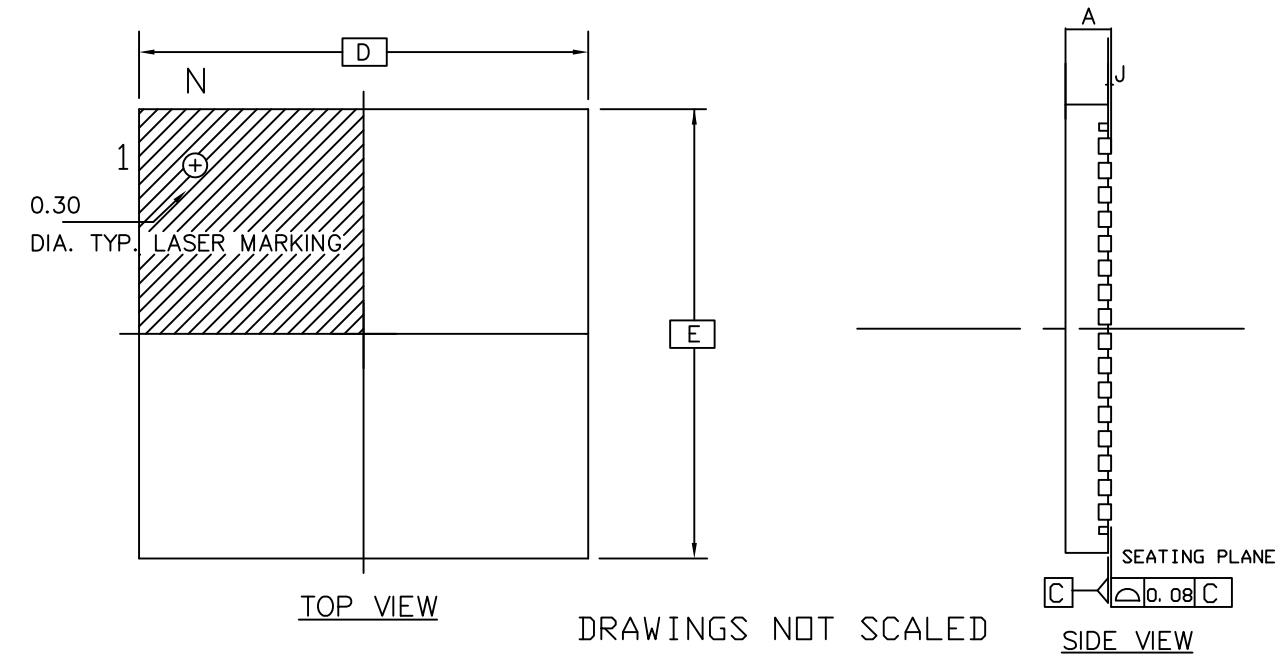

COMMON DIMENSIONS IN MM

SYMBOL	MIN.	NOM.	MAX.	NOTES
A	0.80	----	1.00	
J	0.00	----	0.05	
D/E	9.00 BSC			
D2/E2	3.25	----	7.50	
N	64			
e	0.50 BSC			
L	0.30	0.40	0.55	
b	0.18	0.25	0.30	

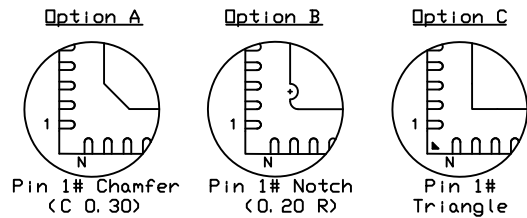



Table 43-12. 64-lead QFN Package Dimensions (in mm)

Symbol	Millimeter			Inch		
	Min	Nom	Max	Min	Nom	Max
A	–	–	090	–	–	0.035
A1	–	–	0.05	–	–	0.001
A2	–	0.65	0.70	–	0.026	0.028
A3	0.20 REF			0.008 REF		
b	0.23	0.25	0.28	0.009	0.010	0.011
D	9.00 bsc			0.354 bsc		
D2	6.95	7.10	7.25	0.274	0.280	0.285
E	9.00 bsc			0.354 bsc		
E2	6.95	7.10	7.25	0.274	0.280	0.285
L	0.35	0.40	0.45	0.014	0.016	0.018
e	0.50 bsc			0.020 bsc		
R	0.125	–	–	0.0005	–	–
Tolerances of Form and Position						
aaa	0.10			0.004		
bbb	0.10			0.004		
ccc	0.05			0.002		

Table 43-13. Device and QFN Package Maximum Weight (Preliminary)

SAM4S	280	mg
-------	-----	----

Table 43-14. QFN Package Reference

JEDEC Drawing Reference	MO-220
JESD97 Classification	e3

Table 43-15. QFN Package Characteristics

Moisture Sensitivity Level	3
----------------------------	---

This package respects the recommendations of the NEMI User Group.

43.1 Soldering Profile

Table 43-16 gives the recommended soldering profile from J-STD-020C.

Table 43-16. Soldering Profile

Profile Feature	Green Package
Average Ramp-up Rate (217°C to Peak)	3° C/sec. max.
Preheat Temperature 175°C ±25°C	180 sec. max.
Temperature Maintained Above 217°C	60 sec. to 150 sec.
Time within 5° C of Actual Peak Temperature	20 sec. to 40 sec.
Peak Temperature Range	260° C
Ramp-down Rate	6° C/sec. max.
Time 25° C to Peak Temperature	8 min. max.

Note: The package is certified to be backward compatible with Pb/Sn soldering profile.

A maximum of three reflow passes is allowed per component.

43.2 Packaging Resources

Land Pattern Definition.

Refer to the following IPC Standards:

- IPC-7351A and IPC-782 (*Generic Requirements for Surface Mount Design and Land Pattern Standards*) <http://landpatterns.ipc.org/default.asp>
- Atmel Green and RoHS Policy and Package Material Declaration Data Sheet <http://www.atmel.com/green/>

44. SAM4S Series Errata

Please refer to the dedicated documents “Errata on SAM4S8/S16 Engineering Sample Devices” and “Errata on SAM4SA16/SD16/SD32 Engineering Sample Devices”.

45. Ordering Information

Table 45-1. Ordering Codes for SAM4S Devices

Ordering Code	MRL	Flash (Kbytes)	Package	Package Type	Temperature Operating Range
ATSAM4SD32CA-CU	A	2*1024	TFBGA100	Green	Industrial (-40°C to +85°C)
ATSAM4SD32CA-CFU	A	2*1024	VFBGA100	Green	Industrial (-40°C to +85°C)
ATSAM4SD32CA-AU	A	2*1024	LQFP100	Green	Industrial (-40°C to +85°C)
ATSAM4SD32BA-MU	A	2*1024	QFN64	Green	Industrial (-40°C to +85°C)
ATSAM4SD32BA-AU	A	2*1024	LQFP64	Green	Industrial (-40°C to +85°C)
ATSAM4SD16CA-CU	A	2*512	TFBGA100	Green	Industrial (-40°C to +85°C)
ATSAM4SD16CA-CFU	A	2*512	VFBGA100	Green	Industrial (-40°C to +85°C)
ATSAM4SD16CA-AU	A	2*512	LQFP100	Green	Industrial (-40°C to +85°C)
ATSAM4SD16BA-MU	A	2*512	QFN64	Green	Industrial (-40°C to +85°C)
ATSAM4SD16BA-AU	A	2*512	LQFP64	Green	Industrial (-40°C to +85°C)
ATSAM4SA16CA-CU	A	1024	TFBGA100	Green	Industrial (-40°C to +85°C)
ATSAM4SA16CA-CFU	A	1024	VFBGA100	Green	Industrial (-40°C to +85°C)
ATSAM4SA16CA-AU	A	1024	LQFP100	Green	Industrial (-40°C to +85°C)
ATSAM4SA16BA-MU	A	1024	QFN64	Green	Industrial (-40°C to +85°C)
ATSAM4SA16BA-AU	A	1024	LQFP64	Green	Industrial (-40°C to +85°C)
ATSAM4S16CA-CU	A	1024	TFBGA100	Green	Industrial (-40°C to +85°C)
ATSAM4S16CA-CFU	A	1024	VFBGA100	Green	Industrial (-40°C to +85°C)
ATSAM4S16CA-AU	A	1024	LQFP100	Green	Industrial (-40°C to +85°C)
ATSAM4S16BA-MU	A	1024	QFN64	Green	Industrial (-40°C to +85°C)
ATSAM4S16BA-AU	A	1024	LQFP64	Green	Industrial (-40°C to +85°C)



Table 45-1. Ordering Codes for SAM4S Devices

Ordering Code	MRL	Flash (Kbytes)	Package	Package Type	Temperature Operating Range
ATSAM4S8CA-CU	A	512	TFBGA100	Green	Industrial (-40°C to +85°C)
ATSAM4S8CA-CFU	A	512	VF BGA100	Green	Industrial (-40°C to +85°C)
ATSAM4S8CA-AU	A	512	LQFP100	Green	Industrial (-40°C to +85°C)
ATSAM4S8BA-MU	A	512	QFN64	Green	Industrial (-40°C to +85°C)
ATSAM4S8BA-AU	A	512	LQFP64	Green	Industrial (-40°C to +85°C)

Doc. Rev. 11100B	Comments	Change Request Ref.
	<p>SUPC References to WFE instructions deleted in Section 17.4.3 “Voltage Regulator Control/Backup Low Power Mode” on page 306. Supply monitor threshold values modified in Section 17.4.4 “Supply Monitor” on page 307. SMTH bit table replaced by a cross-reference to Electrical characteristics in Section 17.5.4 “Supply Controller Supply Monitor Mode Register” on page 316. Typo in Section 17.5.8 “Supply Controller Status Register” on page 321 is now fixed. “half” replaced with “first half” in Section 17.5.6 “Supply Controller Wake Up Mode Register” on page 318 and in Section 17.4.7.2 “Low Power Debouncer Inputs” on page 311. Figure 17-4 on page 310 modified. Push-to-Break figure example Figure 17-6 on page 312 added, title of Figure 17-5 on page 312 modified. “square waveform ..” changed to “duty cycle ..” in Section 17.4.7.2 “Low Power Debouncer Inputs” on page 311. Switching time of slow crystal oscillator updated in Section 17.4.2 “Slow Clock Generator” on page 306.</p>	rfo 8024 8067 8064, 8082 8082 8226 8266
	<p>EEFC Added GPNVM command line in Section • “FARG: Flash Command Argument” on page 342. Unique identifier address changed in Section 19.4.3.8 “Unique Identifier” on page 338. User Signature address changed in Section 19.4.3.9 “User Signature” on page 338. Changed the System Controller base address from 0x400E0800 to 0x400E0A00 in Section 19.5 “Enhanced Embedded Flash Controller (EEFC) User Interface” on page 340.</p>	8076 8274 rfo
	<p>FFPI All references, tables, figures related to 48-bit devices cleared in this whole chapter.</p>	rfo
	<p>CMCC New chapter.</p>	
	<p>CRCCU Typos: CCIT802 corrected to CCITT802, CCIT16 corrected to CCITT16 in Section 22.5.1 “CRC Calculation Unit description” on page 371 and Section 22.7.10 “CRCCU Mode Register” on page 387. TRC_RC corrected to TR_CRC in Section 22.7.10 “CRCCU Mode Register” on page 387.</p>	7803
	<p>SMC “turned out” changed to “switched to output mode” in Section 25.8.4 “Write Mode” on page 426. Removed DBW which is not required for 8-bit only in Section 25.15.4 “SMC MODE Register” on page 453.</p>	7925 8307
	<p>PMC Added a note in Section 27.2.16.7 “PMC Clock Generator Main Oscillator Register” on page 504. Max MULA/MULB value changed from 2047 to 62 in Section 27.2.16.9 “PMC Clock Generator PLLA Register” on page 507 and Section 27.2.16.10 “PMC Clock Generator PLLB Register” on page 508. Step 5 in Section 27.2.13 “Programming Sequence” on page 489: Master Clock option added in CSS field. Third paragraph added in Section 27.2.12 “Main Crystal Clock Failure Detector” on page 488. WAITMODE bit added in Section 27.2.16.7 “PMC Clock Generator Main Oscillator Register” on page 504.</p>	7848 8064 8170 8208
	<p>CHIPID Table 28-1 on page 528 modified.</p>	rfo
	<p>TC Changed TIOA1 in TIOB1 in Section 35.6.14.1 “Description” on page 823 and Section 35.6.14.4 “Position and Rotation Measurement” on page 829.</p>	8101

Doc. Rev. 11100B	Comments	Change Request Ref.
	<p>PWM Font size enlarged in Section 37-14 “Comparison Unit Block Diagram” on page 925. “CMPS” replaced with “CMPM” in whole document.</p>	7910 8021
	<p>ADC EOCAL pin and description added in Section 40.7.12 “ADC Interrupt Status Register” on page 1061. PDC register row added in Section 40.7 “Analog-to-Digital Converter (ADC) User Interface” on page 1047. Added comment in Section 40.7.15 “ADC Compare Window Register” on page 1064. Features added in Section 40.2 “Embedded Characteristics” on page 1033. Comments added, and removed “offset” in Section 40.6.11 “Automatic Calibration” on page 1045.</p>	rfo 7969 8045 8088 8133
	<p>Electrical Characteristics Whole chapter updated. In tables, values updated, and missing values added. Comment for flash erasing added in Section 42.11.9 “Embedded Flash Characteristics” on page 1138. Updated conditions for $V_{LINE-TR}$ and $V_{LOAD-TR}$ in Table 42-3 on page 1096. Removed the “ADREF Current” row from Table 42-27 on page 1114. Updated the “Offset Error” parameter description in Table 42-29 on page 1115. Updated the $T_{ACCURACY}$ parameter description in Table 42-5 on page 1097. Updated the temperature sensor description in Section 42.10 “Temperature Sensor” and the slope accuracy parameter data in Table 42-39 on page 1121.</p>	8085, 8245 8223 rfo rfo rfo
	<p>Mechanical Characteristics 48 pins packages (SAM4S16A and SAM4S8A devices) removed. 100-ball VFBGA package drawing added in Figure 43-3 on page 1142.</p>	8100 rfo
	<p>Ordering Information Table 45-1 on page 1149 completed with new devices and reordered.</p>	rfo
	<p>Errata Removed the Flash Memory section. Added Section 45.3.3.2 “FLASH: Read Error after GPVNM or Lock Bit Writing” on page 1153. Removed the Errata section and added references for two separate errata documents in Section 44. “SAM4S Series Errata” on page 1148.</p>	rfo rfo
	<p>Fixed incorrectly applied variable IP_Name. Fixed incorrectly applied conditions. Specified the preliminary status of the datasheet.</p>	rfo rfo rfo

Doc. Rev. 11100A	Comments	Change Request Ref.
	First issue.	

Table of Contents

	Features	1
1	Description	2
	1.1 Configuration Summary	3
2	Block Diagram	4
3	Signal Description	8
4	Package and Pinout	12
	4.1 SAM4SD32/SD16/SA16/S16/S8C Package and Pinout	12
	4.2 SAM4SD32/SD16/SA16/S16/S8 Package and Pinout	17
5	Power Considerations	19
	5.1 Power Supplies	19
	5.2 Voltage Regulator	19
	5.3 Typical Powering Schematics	19
	5.4 Active Mode	21
	5.5 Low-power Modes	21
	5.6 Wake-up Sources	24
	5.7 Fast Startup	25
6	Input/Output Lines	26
	6.1 General Purpose I/O Lines	26
	6.2 System I/O Lines	26
	6.3 Test Pin	28
	6.4 NRST Pin	28
	6.5 ERASE Pin	28
7	Product Mapping	29
8	Memories	30
	8.1 Embedded Memories	30
	8.2 External Memories	36
9	System Controller	36
	9.1 System Controller and Peripheral Mapping	38
	9.2 Power-on-Reset, Brownout and Supply Monitor	38
10	Peripherals	39

10.1	Peripheral Identifiers	39
10.2	Peripheral Signal Multiplexing on I/O Lines	40
11	ARM Cortex-M4	45
11.1	Description	45
11.2	Embedded Characteristics	46
11.3	Block Diagram	47
11.4	Cortex-M4 Models	48
11.5	Power Management	79
11.6	Cortex-M4 Instruction Set	81
11.7	Cortex-M4 Core Peripherals	180
11.8	Nested Vectored Interrupt Controller (NVIC)	181
11.9	System Control Block (SCB)	192
11.10	System Timer (SysTick)	220
11.11	Memory Protection Unit (MPU)	225
11.12	Glossary	239
12	Debug and Test Features	243
12.1	Description	243
12.2	Embedded Characteristics	243
12.3	Application Examples	244
12.4	Debug and Test Pin Description	245
12.5	Functional Description	246
13	Reset Controller (RSTC)	251
13.1	Description	251
13.2	Embedded Characteristics	251
13.3	Block Diagram	251
13.4	Functional Description	252
13.5	Reset Controller (RSTC) User Interface	259
14	Real-time Timer (RTT)	263
14.1	Description	263
14.2	Embedded Characteristics	263
14.3	Block Diagram	263
14.4	Functional Description	264
14.5	Real-Time Timer (RTT) User Interface	266
15	Real Time Clock (RTC)	271

15.1	Description	271
15.2	Embedded Characteristics	271
15.3	Block Diagram	272
15.4	Product Dependencies	273
15.5	Functional Description	273
15.6	Real-Time Clock (RTC) User Interface	280
16	<i>Watchdog Timer (WDT)</i>	295
16.1	Description	295
16.2	Embedded Characteristics	295
16.3	Block Diagram	296
16.4	Functional Description	297
16.5	Watchdog Timer (WDT) User Interface	299
17	<i>Supply Controller (SUPC)</i>	303
17.1	Description	303
17.2	Embedded Characteristics	303
17.3	Block Diagram	304
17.4	Supply Controller Functional Description	305
17.5	Supply Controller (SUPC) User Interface	314
18	<i>General Purpose Backup Registers (GPBR)</i>	323
18.1	Description	323
18.2	Embedded Characteristics	323
18.3	General Purpose Backup Registers (GPBR) User Interface	323
19	<i>Enhanced Embedded Flash Controller (EEFC)</i>	325
19.1	Description	325
19.2	Embedded Characteristics	325
19.3	Product Dependencies	326
19.4	Functional Description	327
19.5	Enhanced Embedded Flash Controller (EEFC) User Interface	340
20	<i>Fast Flash Programming Interface (FFPI)</i>	345
20.1	Description	345
20.2	Parallel Fast Flash Programming	346
21	<i>Cortex M Cache Controller (CMCC)</i> <i>(ONLY FOR SAM4SD32/SD16/SA16)</i>	355
21.1	Description	355

21.2	Embedded Characteristics	355
21.3	Block Diagram	356
21.4	Functional Description	357
21.5	Cortex M Cache Controller (CMCC) User Interface	358
22	<i>Cyclic Redundancy Check Calculation Unit (CRCCU)</i>	369
22.1	Description	369
22.2	Embedded Characteristics	369
22.3	CRCCU Block Diagram	370
22.4	Product Dependencies	371
22.5	CRCCU Functional Description	371
22.6	Transfer Control Registers Memory Mapping	373
22.7	Cyclic Redundancy Check Calculation Unit (CRCCU) User Interface	377
23	<i>SAM4S Boot Program</i>	393
23.1	Description	393
23.2	Hardware and Software Constraints	393
23.3	Flow Diagram	393
23.4	Device Initialization	394
23.5	SAM-BA Monitor	395
24	<i>Bus Matrix (MATRIX)</i>	399
24.1	Description	399
24.2	Embedded Characteristics	399
24.3	Memory Mapping	400
24.4	Special Bus Granting Techniques	400
24.5	Arbitration	401
24.6	System I/O Configuration	403
24.7	Write Protect Registers	403
24.8	Bus Matrix (MATRIX) User Interface	404
25	<i>Static Memory Controller (SMC)</i>	413
25.1	Description	413
25.2	Embedded Characteristics	413
25.3	I/O Lines Description	414
25.4	Product Dependencies	415
25.5	External Memory Mapping	415
25.6	Connection to External Devices	416
25.7	Application Example	419

25.8	Standard Read and Write Protocols	421
25.9	Scrambling/Unscrambling Function	429
25.10	Automatic Wait States	429
25.11	Data Float Wait States	433
25.12	External Wait	438
25.13	Slow Clock Mode	444
25.14	Asynchronous Page Mode	446
25.15	Static Memory Controller (SMC) User Interface	449
26	<i>Peripheral DMA Controller (PDC)</i>	459
26.1	Description	459
26.2	Embedded Characteristics	459
26.3	Block Diagram	461
26.4	Functional Description	462
26.5	Peripheral DMA Controller (PDC) User Interface	464
27	<i>Power Management Controller (PMC)</i>	475
27.1	Clock Generator	475
27.2	Power Management Controller (PMC)	483
28	<i>Chip Identifier (CHIPID)</i>	527
28.1	Description	527
28.2	Embedded Characteristics	527
28.3	Chip Identifier (CHIPID) User Interface	529
29	<i>Parallel Input/Output Controller (PIO)</i>	535
29.1	Description	535
29.2	Embedded Characteristics	535
29.3	Block Diagram	536
29.4	Product Dependencies	538
29.5	Functional Description	539
29.6	I/O Lines Programming Example	552
29.7	Parallel Input/Output Controller (PIO) User Interface	553
30	<i>Synchronous Serial Controller (SSC)</i>	589
30.1	Description	589
30.2	Embedded Characteristics	589
30.3	Block Diagram	590
30.4	Application Block Diagram	590

30.5	Pin Name List	591
30.6	Product Dependencies	591
30.7	Functional Description	592
30.8	SSC Application Examples	603
30.9	Synchronous Serial Controller (SSC) User Interface	606
31	<i>Serial Peripheral Interface (SPI)</i>	633
31.1	Description	633
31.2	Embedded Characteristics	633
31.3	Block Diagram	634
31.4	Application Block Diagram	634
31.5	Signal Description	635
31.6	Product Dependencies	636
31.7	Functional Description	637
31.8	Serial Peripheral Interface (SPI) User Interface	651
32	<i>Two-wire Interface (TWI)</i>	667
32.1	Description	667
32.2	Embedded Characteristics	667
32.3	List of Abbreviations	668
32.4	Block Diagram	668
32.5	Application Block Diagram	669
32.6	Product Dependencies	670
32.7	Functional Description	671
32.8	Master Mode	672
32.9	Multi-master Mode	684
32.10	Slave Mode	687
32.11	Two-wire Interface (TWI) User Interface	695
33	<i>Universal Asynchronous Receiver Transmitter (UART)</i>	709
33.1	Description	709
33.2	Embedded Characteristics	709
33.3	Block Diagram	710
33.4	Product Dependencies	711
33.5	UART Operations	711
33.6	Universal Asynchronous Receiver Transmitter (UART) User Interface	718
34	<i>Universal Synchronous Asynchronous Receiver Transmitter (USART)</i>	729

34.1	Description	729
34.2	Embedded Characteristics	729
34.3	Block Diagram	730
34.4	Application Block Diagram	731
34.5	I/O Lines Description	731
34.6	Product Dependencies	732
34.7	Functional Description	733
34.8	Universal Synchronous Asynchronous Receiver Transceiver (USART) User Interface	768
35	<i>Timer Counter (TC)</i>	805
35.1	Description	805
35.2	Embedded Characteristics	805
35.3	Block Diagram	806
35.4	Pin Name List	807
35.5	Product Dependencies	807
35.6	Functional Description	808
35.7	Timer Counter (TC) User Interface	832
36	<i>High Speed Multimedia Card Interface (HSMCI)</i>	859
36.1	Description	859
36.2	Embedded Characteristics	859
36.3	Block Diagram	860
36.4	Application Block Diagram	861
36.5	Pin Name List	861
36.6	Product Dependencies	862
36.7	Bus Topology	862
36.8	High Speed MultiMediaCard Operations	865
36.9	SD/SDIO Card Operation	873
36.10	CE-ATA Operation	874
36.11	HSMCI Boot Operation Mode	875
36.12	HSMCI Transfer Done Timings	876
36.13	Write Protection Registers	877
36.14	High Speed Multimedia Card Interface (HSMCI) User Interface	878
37	<i>Pulse Width Modulation Controller (PWM)</i>	905
37.1	Description	905
37.2	Embedded Characteristics	905





37.3	Block Diagram	906
37.4	I/O Lines Description	907
37.5	Product Dependencies	907
37.6	Functional Description	909
37.7	Pulse Width Modulation Controller (PWM) Controller User Interface	934
38	<i>USB Device Port (UDP)</i>	979
38.1	Description	979
38.2	Embedded Characteristics	979
38.3	Block Diagram	980
38.4	Product Dependencies	981
38.5	Typical Connection	982
38.6	Functional Description	982
38.7	USB Device Port (UDP) User Interface	997
39	<i>Analog Comparator Controller (ACC)</i>	1017
39.1	Description	1017
39.2	Embedded Characteristics	1017
39.3	Block Diagram	1018
39.4	Pin Name List	1019
39.5	Product Dependencies	1020
39.6	Functional Description	1021
39.7	Analog Comparator Controller (ACC) User Interface	1022
40	<i>Analog-to-Digital Converter (ADC)</i>	1033
40.1	Description	1033
40.2	Embedded Characteristics	1033
40.3	Block Diagram	1034
40.4	Signal Description	1034
40.5	Product Dependencies	1034
40.6	Functional Description	1036
40.7	Analog-to-Digital Converter (ADC) User Interface	1047
41	<i>Digital-to-Analog Converter Controller (DACC)</i>	1071
41.1	Description	1071
41.2	Embedded Characteristics	1071
41.3	Block Diagram	1072
41.4	Signal Description	1073
41.5	Product Dependencies	1073

41.6	Functional Description	1073
41.7	Digital-to-Analog Converter Controller (DACC) User Interface	1077
42	SAM4S Electrical Characteristics	1093
42.1	Absolute Maximum Ratings	1093
42.2	DC Characteristics	1094
42.3	Power Consumption	1100
42.4	Oscillator Characteristics	1107
42.5	PLLA, PLLB Characteristics	1111
42.6	USB Transceiver Characteristics	1112
42.7	12-Bit ADC Characteristics	1114
42.8	12-Bit DAC Characteristics	1118
42.9	Analog Comparator Characteristics	1120
42.10	Temperature Sensor	1121
42.11	AC Characteristics	1121
43	SAM4S Mechanical Characteristics	1140
43.1	Soldering Profile	1147
43.2	Packaging Resources	1147
44	SAM4S Series Errata	1148
45	Ordering Information	1149
	Revision History.....	1151
	Table of Contents.....	i



Headquarters

Atmel Corporation

2325 Orchard Parkway
San Jose, CA 95131
USA
Tel: (+1) (408) 441-0311
Fax: (+1) (408) 487-2600

International

Atmel Asia Limited

Unit 01-5 & 16, 19F
BEA Tower, Millennium City 5
418 Kwun Tong Road
Kwun Tong, Kowloon
HONG KONG
Tel: (+852) 2245-6100
Fax: (+852) 2722-1369

Atmel Munich GmbH

Business Campus
Parking 4
D-85748 Garching b. Munich
GERMANY
Tel: (+49) 89-31970-0
Fax: (+49) 89-3194621

Atmel Japan

9F, Tonetsu Shinkawa Bldg.
1-24-8 Shinkawa
Chuo-ku, Tokyo 104-0033
JAPAN
Tel: (81) 3-3523-3551
Fax: (81) 3-3523-7581

Product Contact

Web Site

www.atmel.com
www.atmel.com/AT91SAM

Technical Support

[AT91SAM Support](mailto:AT91SAM_Support@atmel.com)
[Atmel technical support](mailto:Atmel_technical_support@atmel.com)

Sales Contacts

www.atmel.com/contacts/

Literature Requests

www.atmel.com/literature

Disclaimer: The information in this document is provided in connection with Atmel products. No license, express or implied, by estoppel or otherwise, to any intellectual property right is granted by this document or in connection with the sale of Atmel products. **EXCEPT AS SET FORTH IN ATMEL'S TERMS AND CONDITIONS OF SALE LOCATED ON ATMEL'S WEB SITE, ATMEL ASSUMES NO LIABILITY WHATSOEVER AND DISCLAIMS ANY EXPRESS, IMPLIED OR STATUTORY WARRANTY RELATING TO ITS PRODUCTS INCLUDING, BUT NOT LIMITED TO, THE IMPLIED WARRANTY OF MERCHANTABILITY, FITNESS FOR A PARTICULAR PURPOSE, OR NON-INFRINGEMENT. IN NO EVENT SHALL ATMEL BE LIABLE FOR ANY DIRECT, INDIRECT, CONSEQUENTIAL, PUNITIVE, SPECIAL OR INCIDENTAL DAMAGES (INCLUDING, WITHOUT LIMITATION, DAMAGES FOR LOSS OF PROFITS, BUSINESS INTERRUPTION, OR LOSS OF INFORMATION) ARISING OUT OF THE USE OR INABILITY TO USE THIS DOCUMENT, EVEN IF ATMEL HAS BEEN ADVISED OF THE POSSIBILITY OF SUCH DAMAGES.** Atmel makes no representations or warranties with respect to the accuracy or completeness of the contents of this document and reserves the right to make changes to specifications and product descriptions at any time without notice. Atmel does not make any commitment to update the information contained herein. Unless specifically provided otherwise, Atmel products are not suitable for, and shall not be used in, automotive applications. Atmel's products are not intended, authorized, or warranted for use as components in applications intended to support or sustain life.



© 2012 Atmel Corporation. All rights reserved. Atmel®, Atmel logo and combinations thereof, DataFlash®, SAM-BA® and others are registered trademarks or trademarks of Atmel Corporation or its subsidiaries. ARM®, ARMPowered® logo, Cortex™, Thumb® -2 and others are registered trademarks or trademarks of ARM Ltd. Windows® and others are registered trademarks or trademarks of Microsoft Corporation in the US and/or other countries. Other terms and product names may be trademarks of others.