



## Precision Analog-to-Digital Converter (ADC) and Digital-to-Analog Converters (DACs) with 8051 Microcontroller and Flash Memory

### FEATURES

#### ANALOG FEATURES

- 24-BITS NO MISSING CODES
- 22-BITS EFFECTIVE RESOLUTION AT 10Hz  
Low Noise: 75nV
- PGA FROM 1 TO 128
- PRECISION ON-CHIP VOLTAGE REFERENCE:  
Accuracy: 0.2%  
Drift: 5ppm/°C
- 8 DIFFERENTIAL/SINGLE-ENDED CHANNELS
- ON-CHIP OFFSET/GAIN CALIBRATION
- OFFSET DRIFT: 0.02PPM/°C
- GAIN DRIFT: 0.5PPM/°C
- ON-CHIP TEMPERATURE SENSOR
- SELECTABLE BUFFER INPUT
- BURNOUT DETECT
- QUAD 16-BIT MONOTONIC VOLTAGE DACs:  
2 VDACs Can Be Programmed as IDACs  
8 $\mu$ s Settling Time

#### DIGITAL FEATURES

##### Microcontroller Core

- 8051 COMPATIBLE
- HIGH SPEED CORE:  
4 Clocks per Instruction Cycle
- DC TO 30MHz
- SINGLE INSTRUCTION 133ns
- DUAL DATA POINTER

##### Memory

- UP TO 32kB FLASH DATA MEMORY
- FLASH MEMORY PARTITIONING
- ENDURANCE 1M ERASE/WRITE CYCLES,  
100 YEAR DATA RETENTION
- IN-SYSTEM SERIALLY PROGRAMMABLE
- EXTERNAL PROGRAM/DATA MEMORY (64kB)
- 1280 BYTES DATA SRAM
- FLASH MEMORY SECURITY
- 2kB BOOT ROM
- PROGRAMMABLE WAIT STATE CONTROL

#### Peripheral Features

- 34 I/O PINS
- ADDITIONAL 32-BIT ACCUMULATOR
- THREE 16-BIT TIMER/COUNTERS
- SYSTEM TIMERS
- PROGRAMMABLE WATCHDOG TIMER
- FULL DUPLEX DUAL UART
- MASTER/SLAVE SPI™ WITH DMA
- 16-BIT PWM
- POWER MANAGEMENT CONTROL
- INTERNAL CLOCK DIVIDER
- IDLE MODE CURRENT < 200 $\mu$ A
- STOP MODE CURRENT < 100nA
- PROGRAMMABLE BROWNOUT RESET
- PROGRAMMABLE LOW VOLTAGE DETECT
- 21 INTERRUPT SOURCES
- TWO HARDWARE BREAKPOINTS

#### GENERAL FEATURES

- PIN COMPATIBLE WITH MSC1210, MSC1211  
FAMILY
- PACKAGE: TQFP-64
- LOW POWER: 4mW
- INDUSTRIAL TEMPERATURE RANGE:  
–40°C to +85°C
- POWER SUPPLY: 2.7V to 5.25V

### APPLICATIONS

- INDUSTRIAL PROCESS CONTROL
- INSTRUMENTATION
- LIQUID/GAS CHROMATOGRAPHY
- BLOOD ANALYSIS
- SMART TRANSMITTERS
- PORTABLE INSTRUMENTS
- WEIGH SCALES
- PRESSURE TRANSDUCERS
- INTELLIGENT SENSORS
- PORTABLE APPLICATIONS
- DAS SYSTEMS



Please be aware that an important notice concerning availability, standard warranty, and use in critical applications of Texas Instruments semiconductor products and disclaimers thereto appears at the end of this data sheet.

All trademarks are the property of their respective owners.

PRODUCTION DATA information is current as of publication date. Products conform to specifications per the terms of Texas Instruments standard warranty. Production processing does not necessarily include testing of all parameters.

## PACKAGE/ORDERING INFORMATION

| PRODUCT   | FLASH MEMORY | PACKAGE-LEAD | PACKAGE DESIGNATOR <sup>(1)</sup> | SPECIFIED TEMPERATURE RANGE | PACKAGE MARKING | ORDERING NUMBER | TRANSPORT MEDIA, QUANTITY |
|-----------|--------------|--------------|-----------------------------------|-----------------------------|-----------------|-----------------|---------------------------|
| MSC1212Y2 | 4k           | TQFP-64      | PAG                               | -40°C to +85°C              | MSC1212Y2       | MSC1212Y2PAGT   | Tape and Reel, 250        |
| MSC1212Y2 | 4k           | "            | "                                 | "                           | "               | MSC1212Y2PAGR   | Tape and Reel, 2000       |
| MSC1212Y3 | 8k           | TQFP-64      | PAG                               | -40°C to +85°C              | MSC1212Y3       | MSC1212Y3PAGT   | Tape and Reel, 250        |
| MSC1212Y3 | 8k           | "            | "                                 | "                           | "               | MSC1212Y3PAGR   | Tape and Reel, 2000       |
| MSC1212Y4 | 16k          | TQFP-64      | PAG                               | -40°C to +85°C              | MSC1212Y4       | MSC1212Y4PAGT   | Tape and Reel, 250        |
| MSC1212Y4 | 16k          | "            | "                                 | "                           | "               | MSC1212Y4PAGR   | Tape and Reel, 2000       |
| MSC1212Y5 | 32k          | TQFP-64      | PAG                               | -40°C to +85°C              | MSC1212Y5       | MSC1212Y5PAGT   | Tape and Reel, 250        |
| MSC1212Y5 | 32k          | "            | "                                 | "                           | "               | MSC1212Y5PAGR   | Tape and Reel, 2000       |

NOTE: (1) For the most current specifications and package information, refer to our web site at [www.ti.com/msc](http://www.ti.com/msc).

## ABSOLUTE MAXIMUM RATINGS<sup>(1)</sup>

|   |  |
|---|--|
| Analog Inputs   |  |
| Input Current .....   | 100mA, Momentary                       |
| Input Current .....   | 10mA, Continuous                       |
| Input Voltage .....   | AGND - 0.5V to AV <sub>DD</sub> + 0.5V |
| Power Supply  |  |
| DV <sub>DD</sub> to DGND .....                                  | -0.3V to 6V                            |
| AV <sub>DD</sub> to AGND .....                                  | -0.3V to 6V                            |
| AGND to DGND .....  | -0.3V to +0.3V                         |
| V <sub>REF</sub> to AGND .....                                  | -0.3V to AV <sub>DD</sub> + 0.3V       |
| Digital Input Voltage to DGND .....                             | -0.3V to DV <sub>DD</sub> + 0.3V       |
| Digital Output Voltage to DGND .....                            | -0.3V to DV <sub>DD</sub> + 0.3V       |
| Maximum Junction Temperature .....                              | +150°C                                 |
| Operating Temperature Range .....                               | -40°C to +85°C                         |
| Storage Temperature Range .....                                 | -65°C to +150°C                        |
| Lead Temperature (soldering, 10s) .....                         | +300°C                                 |
| Package Power Dissipation .....                                 | 900mW                                  |
| Output Current All Pins .....                                   | 200mA                                  |
| Output Pin Short Circuit .....                                  | 10s                                    |
| Thermal Resistance, Junction-to-Ambient ( $\theta_{JA}$ ) ..... | 66.6°C/W                               |
| Thermal Resistance, Junction-to-Case ( $\theta_{JC}$ ) .....    | 4.3°C/W                                |
| Digital Outputs   |  |
| Output Current .....  | 100mA, Continuous                      |
| I/O Source/Sink Current .....                                   | 100mA                                  |
| Power Pin Maximum .....   | 300mA                                  |

NOTE: (1) Stresses beyond those listed under "Absolute Maximum Ratings" may cause permanent damage to the device. Exposure to absolute-maximum-rated conditions for extended periods may affect device reliability.

## MSC1212Yx FAMILY FEATURES

| FEATURES <sup>(1)</sup>              | MSC1212Y2 <sup>(2)</sup> | MSC1212Y3 <sup>(2)</sup> | MSC1212Y4 <sup>(2)</sup> | MSC1212Y5 <sup>(2)</sup> |
|--------------------------------------|--------------------------|--------------------------|--------------------------|--------------------------|
| Flash Program Memory (Bytes)         | Up to 4k                 | Up to 8k                 | Up to 16k                | Up to 32k                |
| Flash Data Memory (Bytes)            | Up to 4k                 | Up to 8k                 | Up to 16k                | Up to 32k                |
| Internal Scratchpad RAM (Bytes)      | 256                      | 256                      | 256                      | 256                      |
| Internal MOVX SRAM (Bytes)           | 1024                     | 1024                     | 1024                     | 1024                     |
| Externally Accessible Memory (Bytes) | 64k Program, 64k Data    | 64k Program, 64k Data    | 64k Program, 64k Data    | 64k Program, 64k Data    |

NOTES: (1) All peripheral features are the same on all devices; the flash memory size is the only difference. (2) The last digit of the part number (N) represents the onboard flash size = (2<sup>N</sup>)kBytes.



## ELECTROSTATIC DISCHARGE SENSITIVITY

This integrated circuit can be damaged by ESD. Texas Instruments recommends that all integrated circuits be handled with appropriate precautions. Failure to observe proper handling and installation procedures can cause damage.

ESD damage can range from subtle performance degradation to complete device failure. Precision integrated circuits may be more susceptible to damage because very small parametric changes could cause the device not to meet its published specifications.

# ELECTRICAL CHARACTERISTICS: $AV_{DD} = 5V$

All specifications from  $T_{MIN}$  to  $T_{MAX}$ ,  $DV_{DD} = +2.7V$  to  $5.25V$ ,  $f_{MOD} = 15.625kHz$ ,  $PGA = 1$ , Buffer ON,  $f_{DATA} = 10Hz$ , Bipolar, and  $V_{REF} \equiv (REF\ IN+) - (REF\ IN-) = +2.5V$ , unless otherwise noted. For  $V_{DAC}$ ,  $V_{REF} = AV_{DD}$ ,  $R_{LOAD} = 10k\Omega$ , and  $C_{LOAD} = 200pF$ , unless otherwise noted.

| PARAMETER  | CONDITION  | MSC1212Yx                 |                             |   | UNITS         |
|--|--|---------------------------|-----------------------------|---|---------------|
|  |  | MIN                       | TYP                         | MAX   |               |
| <b>ANALOG INPUT</b> (AIN0-AIN7, AINCOM)<br>Analog Input Range      | Buffer OFF<br>Buffer ON  | AGND – 0.1<br>AGND + 50mV |                             | $AV_{DD} + 0.1$<br>$AV_{DD} - 1.5$<br>$\pm V_{REF}/PGA$ | V<br>V        |
| Full-Scale Input Voltage Range                                     | (In+) – (In–) See Figure 4   |                           |                             |   | V             |
| Differential Input Impedance                                       | Buffer OFF   |                           | 5/PGA                       |   | MΩ            |
| Input Current  | Buffer ON  |                           | 0.5                         |   | nA            |
| Bandwidth  |  |                           |                             |   |               |
| Fast Settling Filter   | –3dB   |                           | $0.469 \cdot f_{DATA}$      |   |               |
| Sinc <sup>2</sup> Filter   | –3dB   |                           | $0.318 \cdot f_{DATA}$      |   |               |
| Sinc <sup>3</sup> Filter   | –3dB   |                           | $0.262 \cdot f_{DATA}$      |   |               |
| Programmable Gain Amplifier  | User-Selectable Gain Ranges  | 1                         |                             | 128   |               |
| Input Capacitance  | Buffer ON  |                           | 4                           |   | pF            |
| Input Leakage Current  | Multiplexer Channel Off, T = +25°C                                 |                           | 0.5                         |   | pA            |
| Burnout Current Sources  | Sensor Input Open Circuit  |                           | ±2                          |   | μA            |
| <b>ADC OFFSET DAC</b><br>Offset DAC Range                          |  | 8                         | $\pm V_{REF}/(2 \cdot PGA)$ |   | V             |
| Offset DAC Monotonicity  |  |                           |                             |   | Bits          |
| Offset DAC Gain Error  |  |                           | ±1.5                        |   | % of Range    |
| Offset DAC Gain Error Drift  |  |                           | 1                           |   | ppm/°C        |
| <b>SYSTEM PERFORMANCE</b><br>Resolution                            |  | 24                        |                             |   | Bits          |
| ENOB   |  |                           | 22                          |   | Bits          |
| Output Noise   |  |                           | See Typical Characteristics |   |               |
| No Missing Codes   | Sinc <sup>3</sup> Filter   | 24                        |                             |   | Bits          |
| Integral Nonlinearity  | End Point Fit, Differential Input                                  |                           |                             | ±0.0015   | %FSR          |
| Offset Error   | After Calibration  |                           | 7.5                         |   | ppm of FS     |
| Offset Drift <sup>(1)</sup>  | Before Calibration   |                           | 0.02                        |   | ppm of FS/°C  |
| Gain Error <sup>(2)</sup>  | After Calibration  |                           | 0.005                       |   | %             |
| Gain Error Drift <sup>(1)</sup>                                    | Before Calibration   |                           | 0.5                         |   | ppm/°C        |
| System Gain Calibration Range                                      |  | 80                        |                             | 120   | % of FS       |
| System Offset Calibration Range                                    |  | –50                       |                             | 50  | % of FS       |
| Common-Mode Rejection  | At DC  | 100                       | 115                         |   | dB            |
|  | $f_{CM} = 60Hz, f_{DATA} = 10Hz$                                   |                           | 130                         |   | dB            |
|  | $f_{CM} = 50Hz, f_{DATA} = 50Hz$                                   |                           | 120                         |   | dB            |
|  | $f_{CM} = 60Hz, f_{DATA} = 60Hz$                                   |                           | 120                         |   | dB            |
| Normal Mode Rejection  | $f_{SIG} = 50Hz, f_{DATA} = 50Hz$                                  |                           | 100                         |   | dB            |
|  | $f_{SIG} = 60Hz, f_{DATA} = 60Hz$                                  |                           | 100                         |   | dB            |
| Power-Supply Rejection   | At DC, dB = $-20\log(\Delta V_{OUT}/\Delta V_{DD})$ <sup>(3)</sup> |                           | 88                          |   | dB            |
| <b>VOLTAGE REFERENCE INPUTS</b><br>Reference Input Range           | REF IN+, REF IN–   | 0.0                       |                             | $AV_{DD}$ <sup>(2)</sup>                                | V             |
| ADC $V_{REF}$  | $V_{REF} \equiv (REF\ IN+) - (REF\ IN-)$                           | 0.3                       | 2.5                         | $AV_{DD}$   | V             |
| Common-Mode Rejection  | At DC  |                           | 110                         |   | dB            |
| Input Current <sup>(4)</sup>                                       | $V_{REF} = 2.5V$ , ADC Only  |                           | 10                          |   | μA            |
| DAC Reference Current  | For Each DAC, 5V Reference   |                           | 25                          |   | μA            |
| <b>ON-CHIP VOLTAGE REFERENCE</b><br>Output Voltage                 | $V_{REFH} = 1$ at +25°C, PGA = 1, 2, 4, 8<br>$V_{REFH} = 0$        | 2.495                     | 2.5<br>1.25                 | 2.505   | V<br>V        |
| Power-Supply Rejection Ratio                                       |  |                           | 65                          |   | dB            |
| Short-Circuit Current Source                                       |  |                           | 8                           |   | mA            |
| Short-Circuit Current Sink   |  |                           | 50                          |   | μA            |
| Short-Circuit Duration   | Sink or Source   |                           | Indefinite                  |   |               |
| Drift  |  |                           | 5                           |   | ppm/°C        |
| Output Impedance   | Sourcing 100μA   |                           | 3                           |   | Ω             |
| Startup Time from Power ON   | $C_{REFOUT} = 0.1\mu F$  |                           | 8                           |   | ms            |
| Temperature Sensor   |  |                           |                             |   |               |
| Temperature Sensor Voltage   | T = +25°C  |                           | 115                         |   | mV            |
| Temperature Sensor Coefficient                                     |  |                           | 375                         |   | μV/°C         |
| <b>VOLTAGE DAC STATIC PERFORMANCE</b> <sup>(5)</sup><br>Resolution |  | 16                        |                             |   | Bits          |
| Relative Accuracy  |  |                           | ±0.05                       | ±0.146  | %             |
| Differential Nonlinearity  |  |                           |                             | ±1  | LSB           |
| Zero Code Error  | All 0s Loaded to DAC Register                                      |                           | +13                         | +35   | mV            |
| Full-Scale Error   | All 1s Loaded to DAC Register                                      | –1.25                     | 0                           |   | % of FSR      |
| Gain Error   |  | –1.25                     | 0                           | +1.25   | % of FSR      |
| Zero Code Error Drift  |  |                           | ±20                         |   | μV/°C         |
| Gain Temperature Coefficient                                       |  |                           | ±5                          |   | ppm of FSR/°C |

# ELECTRICAL CHARACTERISTICS: $AV_{DD} = 5V$ (Cont.)

All specifications from  $T_{MIN}$  to  $T_{MAX}$ ,  $DV_{DD} = +2.7V$  to  $5.25V$ ,  $f_{MOD} = 15.625kHz$ ,  $PGA = 1$ , Buffer ON,  $f_{DATA} = 10Hz$ , Bipolar, and  $V_{REF} \equiv (REF\ IN+) - (REF\ IN-) = +2.5V$ , unless otherwise noted. For  $V_{DAC}$ ,  $V_{REF} = AV_{DD}$ ,  $R_{LOAD} = 10k\Omega$ , and  $C_{LOAD} = 200pF$ , unless otherwise noted.

| PARAMETER   | CONDITION   | MSC1212Yx |   |           | UNITS  |
|---|---|-----------|---|-----------|--|
|   |   | MIN       | TYP   | MAX       |  |
| <b>VOLTAGE DAC OUTPUT CHARACTERISTICS<sup>(6)</sup></b><br>Output Voltage Range<br>Output Voltage Settling Time<br>Slew Rate<br>DC Output Impedance<br>Short-Circuit Current                              | To $\pm 0.003\%$ FSR, 0200 <sub>H</sub> to FD00 <sub>H</sub><br><br>All 1s Loaded to DAC Register   | AGND      | 8<br>1<br>7<br>20   | $AV_{DD}$ | V<br>$\mu s$<br>V/ $\mu s$<br>$\Omega$<br>mA                   |
| <b>IDAC OUTPUT CHARACTERISTICS</b><br>Full-Scale Output Current<br>Maximum Short-Circuit Current Duration<br>Compliance Voltage<br>Relative Accuracy<br>Zero Code Error<br>Full-Scale Error<br>Gain Error | Maximum $V_{REF} = 2.5V$<br><br>Over Full Range   |           | 25<br>Indefinite<br>$AV_{DD} - 1.5$<br>0.185<br>0.5<br>-0.4<br>-0.6 |           | mA<br><br>V<br>% of FSR<br>% of FSR<br>% of FSR<br>% of FSR    |
| <b>ANALOG POWER-SUPPLY REQUIREMENTS</b><br>Power-Supply Voltage<br>Analog Current<br>ADC Current<br><br>VDAC Current<br>$V_{REF}$ Supply Current  | $AV_{DD}$<br>Analog OFF, PDAD = 1<br>PGA = 1, Buffer OFF<br>PGA = 128, Buffer OFF<br>PGA = 1, Buffer ON<br>PGA = 128, Buffer ON<br>Excluding Load Current External Reference<br>ADC ON, $V_{DAC}$ OFF | 4.75      | < 1<br>200<br>500<br>240<br>850<br>250<br>250                       | 5.25      | V<br>nA<br>$\mu A$<br>$\mu A$<br>$\mu A$<br>$\mu A$<br>$\mu A$ |

NOTES: (1) Calibration can minimize these errors. (2) The gain calibration cannot have a REF IN+ of more than  $AV_{DD} - 1.5V$  with buffer ON. To calibrate gain, turn buffer off. (3)  $DV_{OUT}$  is change in digital result. (4) 12pF switched capacitor at  $f_{SAMP}$  clock frequency (see Figure 6). (5) Linearity calculated using a reduced code range of 512 to 65024; output unloaded. (6) Ensured by design and characterization, not production tested.

# ELECTRICAL CHARACTERISTICS: $AV_{DD} = 3V$

All specifications from  $T_{MIN}$  to  $T_{MAX}$ ,  $AV_{DD} = +3V$ ,  $DV_{DD} = +2.7V$  to  $5.25V$ ,  $f_{MOD} = 15.625kHz$ ,  $PGA = 1$ , Buffer ON,  $f_{DATA} = 10Hz$ , Bipolar, and  $V_{REF} \equiv (REF\ IN+) - (REF\ IN-) = +1.25V$ , unless otherwise noted. For  $V_{DAC}$ ,  $V_{REF} = AV_{DD}$ ,  $R_{LOAD} = 10k\Omega$ , and  $C_{LOAD} = 200pF$ , unless otherwise noted.

| PARAMETER   | CONDITION   | MSC1212Yx                 |  |  | UNITS  |
|---|---|---------------------------|--|--|--|
|   |   | MIN                       | TYP  | MAX  |  |
| <b>ANALOG INPUT (AIN0-AIN7, AINCOM)</b><br>Analog Input Range<br><br>Full-Scale Input Voltage Range<br>Differential Input Impedance<br>Input Current<br>Bandwidth<br>Fast Settling Filter<br>Sinc <sup>2</sup> Filter<br>Sinc <sup>3</sup> Filter<br>Programmable Gain Amplifier<br>Input Capacitance<br>Input Leakage Current<br>Burnout Current Sources | Buffer OFF<br>Buffer ON<br>(In+) - (In-) See Figure 4<br>Buffer OFF<br>Buffer ON<br><br>User-Selectable Gain Ranges<br>Buffer On<br>Multiplexer Channel Off, T = +25°C<br>Sensor Input Open Circuit | AGND - 0.1<br>AGND + 50mV | 5/PGA<br>0.5<br><br>0.469 • $f_{DATA}$<br>0.318 • $f_{DATA}$<br>0.262 • $f_{DATA}$ | $AV_{DD} + 0.1$<br>$AV_{DD} - 1.5$<br>$\pm V_{REF}/PGA$<br><br>128 | V<br>V<br>V<br>M $\Omega$<br>nA<br><br>pF<br>pA<br>$\mu A$   |
| <b>ADC OFFSET DAC</b><br>Offset DAC Range<br>Offset DAC Monotonicity<br>Offset DAC Gain Error<br>Offset DAC Gain Error Drift  |   | 8                         | $\pm V_{REF}/(2 \cdot PGA)$<br><br>$\pm 1.5$<br>1                                  |  | V<br>Bits<br>% of Range<br>ppm/°C  |
| <b>SYSTEM PERFORMANCE</b><br>Resolution<br>ENOB<br>Output Noise<br>No Missing Codes<br>Integral Nonlinearity<br>Offset Error<br>Offset Drift <sup>(1)</sup><br>Gain Error <sup>(2)</sup><br>Gain Error Drift <sup>(1)</sup><br>System Gain Calibration Range<br>System Offset Calibration Range   | Sinc <sup>3</sup> Filter<br>End Point Fit, Differential Input<br>After Calibration<br>Before Calibration<br>After Calibration<br>Before Calibration   | 24<br><br>24              | 22<br><br>See Typical Characteristics<br>7.5<br>0.02<br>0.005<br>1.0               | $\pm 0.0015$   | Bits<br>Bits<br><br>Bits<br>%FSR<br>ppm of FS<br>ppm of FS/°C<br>%<br>ppm/°C<br>% of FS<br>% of FS |

# ELECTRICAL CHARACTERISTICS: $AV_{DD} = 3V$ (Cont.)

All specifications from  $T_{MIN}$  to  $T_{MAX}$ ,  $AV_{DD} = +3V$ ,  $DV_{DD} = +2.7V$  to  $5.25V$ ,  $f_{MOD} = 15.625kHz$ ,  $PGA = 1$ , Buffer ON,  $f_{DATA} = 10Hz$ , and Bipolar,  $V_{REF} = (REF\ IN+) - (REF\ IN-) = +1.25V$ , unless otherwise noted. For  $V_{DAC}$ ,  $V_{REF} = AV_{DD}$ ,  $R_{LOAD} = 10k\Omega$ , and  $C_{LOAD} = 200pF$ , unless otherwise noted.

| PARAMETER   | CONDITION  | MSC1212Yx |                 |                 | UNITS                   |
|---|--|-----------|-----------------|-----------------|-------------------------|
|   |  | MIN       | TYP             | MAX             |                         |
| <b>SYSTEM PERFORMANCE (Cont.)</b>                       |  |           |                 |                 |                         |
| Common-Mode Rejection                                   | At DC  | 100       | 115             |                 | dB                      |
|   | $f_{CM} = 60Hz, f_{DATA} = 10Hz$                             |           | 130             |                 | dB                      |
|   | $f_{CM} = 50Hz, f_{DATA} = 50Hz$                             |           | 120             |                 | dB                      |
| Normal Mode Rejection                                   | $f_{CM} = 60Hz, f_{DATA} = 60Hz$                             |           | 120             |                 | dB                      |
|   | $f_{SIG} = 50Hz, f_{DATA} = 50Hz$                            |           | 100             |                 | dB                      |
|   | $f_{SIG} = 60Hz, f_{DATA} = 60Hz$                            |           | 100             |                 | dB                      |
| Power-Supply Rejection                                  | At DC, $dB = -20\log(DV_{OUT}/DV_{DD})^{(3)}$                |           | 85              |                 | dB                      |
| <b>VOLTAGE REFERENCE INPUTS</b>                         |  |           |                 |                 |                         |
| Reference Input Range                                   | REF IN+, REF IN-   | 0.0       |                 | $AV_{DD}^{(2)}$ | V                       |
| ADC $V_{REF}$   | $V_{REF} = (REF\ IN+) - (REF\ IN-)$                          | 0.3       | 1.25            | $AV_{DD}$       | V                       |
| Common-Mode Rejection                                   | At DC  |           | 110             |                 | dB                      |
| Input Current <sup>(4)</sup>                            | $V_{REF} = 1.25V$ , ADC Only                                 |           | 10              |                 | $\mu A$                 |
| DAC Reference Current                                   | For each DAC, 3V Reference                                   |           | 25              |                 | $\mu A$                 |
| <b>ON-CHIP VOLTAGE REFERENCE</b>                        |  |           |                 |                 |                         |
| Output Voltage  | $V_{REFH} = 0$ at $+25^{\circ}C$ , $PGA = 1, 2, 4, 8$        | 1.245     | 1.25            | 1.255           | V                       |
| Power-Supply Rejection Ratio                            |  |           | 65              |                 | dB                      |
| Short-Circuit Current Source                            |  |           | 2.6             |                 | mA                      |
| Short-Circuit Current Sink                              |  |           | 50              |                 | $\mu A$                 |
| Short-Circuit Duration                                  | Sink or Source   |           | Indefinite      |                 |                         |
| Drift   |  |           | 5               |                 | ppm/ $^{\circ}C$        |
| Output Impedance  | Sourcing 100 $\mu A$   |           | 3               |                 | $\Omega$                |
| Startup Time from Power ON                              | $C_{REFOUT} = 0.1\mu F$                                      |           | 8               |                 | ms                      |
| Temperature Sensor                                      |  |           |                 |                 |                         |
| Temperature Sensor Voltage                              | $T = +25^{\circ}C$   |           | 115             |                 | mV                      |
| Temperature Sensor Coefficient                          |  |           | 375             |                 | $\mu V/^{\circ}C$       |
| <b>VOLTAGE DAC STATIC PERFORMANCE<sup>(5)</sup></b>     |  |           |                 |                 |                         |
| Resolution  |  | 16        |                 |                 | Bits                    |
| Relative Accuracy                                       |  |           | $\pm 0.05$      | $\pm 0.146$     | % of FSR                |
| Differential Nonlinearity                               | Ensured Monotonic by Design                                  |           |                 | $\pm 1$         | LSB                     |
| Zero Code Error   | All 0s Loaded to DAC Register                                |           | +13             | +35             | mV                      |
| Full-Scale Error  | All 1s Loaded to DAC Register                                | -1.25     | 0               |                 | % of FSR                |
| Gain Error  |  | -1.25     | 0               | $\pm 1.25$      | % of FSR                |
| Zero Code Error Drift                                   |  |           | $\pm 20$        |                 | $\mu V/^{\circ}C$       |
| Gain Temperature Coefficient                            |  |           | $\pm 5$         |                 | ppm of FSR/ $^{\circ}C$ |
| <b>VOLTAGE DAC OUTPUT CHARACTERISTICS<sup>(6)</sup></b> |  |           |                 |                 |                         |
| Output Voltage Range                                    |  | AGND      |                 | $AV_{DD}$       | V                       |
| Output Voltage Settling Time                            | To $\pm 0.003\%$ FSR, 0200 <sub>H</sub> to FD00 <sub>H</sub> |           | 8               |                 | $\mu s$                 |
| Slew Rate   |  |           | 1               |                 | V/ $\mu s$              |
| DC Output Impedance                                     |  |           | 7               |                 | $\Omega$                |
| Short-Circuit Current                                   | All 1s Loaded to DAC Register                                |           | 16              |                 | mA                      |
| <b>IDAC OUTPUT CHARACTERISTICS</b>                      |  |           |                 |                 |                         |
| Full-Scale Output Current                               | Maximum $V_{REF} = 2.5V$                                     |           | 25              |                 | mA                      |
| Maximum Short-Circuit Current Duration                  |  |           | Indefinite      |                 |                         |
| Compliance Voltage                                      |  |           | $AV_{DD} - 1.5$ |                 |                         |
| Relative Accuracy                                       | Over Full Range  |           | 0.185           |                 | % of FSR                |
| Zero Code Error   |  |           | 0.5             |                 | % of FSR                |
| Full-Scale Error  |  |           | -0.4            |                 | % of FSR                |
| Gain Error  |  |           | -0.6            |                 | % of FSR                |
| <b>POWER-SUPPLY REQUIREMENTS</b>                        |  |           |                 |                 |                         |
| Power-Supply Voltage                                    | $AV_{DD}$  | 2.7       |                 | 3.6             | V                       |
| Analog Current  | Analog OFF, PDAD = 1   |           | < 1             |                 | nA                      |
| ADC Current   | $I_{ADC} + I_{VREF}$<br>$I_{ADC}$<br>PGA = 1, Buffer OFF     |           | 200             |                 | $\mu A$                 |
|   | PGA = 128, Buffer OFF  |           | 500             |                 | $\mu A$                 |
|   | PGA = 1, Buffer ON   |           | 240             |                 | $\mu A$                 |
|   | PGA = 128, Buffer ON   |           | 850             |                 | $\mu A$                 |
| $V_{DAC}$ Current                                       | $I_{VDAC}$<br>Excluding Load Current External Reference      |           | 250             |                 | $\mu A$                 |
| $V_{REF}$ Current                                       | $I_{VREF}$   |           | 250             |                 | $\mu A$                 |

NOTES: (1) Calibration can minimize these errors. (2) The gain calibration cannot have a REF IN+ of more than  $AV_{DD} - 1.5V$  with buffer ON. To calibrate gain, turn buffer off. (3)  $DV_{OUT}$  is change in digital result. (4) 12pF switched capacitor at  $f_{SAMP}$  clock frequency (see Figure 6). (5) Linearity calculated using a reduced code range of 512 to 65024; output unloaded. (6) Ensured by design and characterization, not production tested.

# DIGITAL CHARACTERISTICS: $DV_{DD} = 2.7V$ to $5.25V$

All specifications from  $T_{MIN}$  to  $T_{MAX}$ , unless otherwise specified.

| PARAMETER  | CONDITION  | MSC1212Yx   |  |   | UNITS  |
|--|--|---|--|---|--|
|  |  | MIN   | TYP  | MAX   |  |
| <b>POWER-SUPPLY REQUIREMENTS</b>   | $DV_{DD}$<br>Normal Mode, $f_{OSC} = 1MHz$<br>Normal Mode, $f_{OSC} = 8MHz$<br>Stop Mode   | 2.7   | 1.3<br>6<br>100  | 3.6   | V<br>mA<br>mA<br>nA  |
|  | $DV_{DD}$<br>Normal Mode, $f_{OSC} = 1MHz$<br>Normal Mode, $f_{OSC} = 8MHz$<br>Stop Mode   | 4.75  | 2.2<br>14<br>100   | 5.25  | V<br>mA<br>mA<br>nA  |
| <b>DIGITAL INPUT/OUTPUT (CMOS)</b><br>Logic Level: $V_{IH}$ (except XIN pin)<br>$V_{IL}$ (except XIN pin)<br>Ports 0-3, Input Leakage Current, Input Mode<br>Pins $\overline{EA}$ , XIN Input Leakage Current<br>$V_{OL}$ , ALE, $\overline{PSEN}$ , Ports 0-3, All Output Modes<br>$V_{OL}$ , ALE, $\overline{PSEN}$ , Ports 0-3, All Output Modes<br>$V_{OH}$ , ALE, $\overline{PSEN}$ , Ports 0-3, Strong Drive Output<br>$V_{OH}$ , ALE, $\overline{PSEN}$ , Ports 0-3, Strong Drive Output<br>Ports 0-3 Pull-Up Resistors<br>Pins ALE, $\overline{PSEN}$ , Pull-Up Resistors<br>Pin RST, Pull-Down Resistor | $V_{IH} = DV_{DD}$ or $V_{IH} = 0V$<br><br>$I_{OL} = 1mA$<br>$I_{OL} = 30mA, 3V (20mA)$<br>$I_{OH} = 1mA$<br>$I_{OH} = 30mA, 3V (20mA)$<br><br>Flash Programming Mode Only | $0.6 \cdot DV_{DD}$<br>DGND<br>-10<br><br>DGND<br><br>$DV_{DD} - 0.4$ | <br>0<br>0<br>1.5<br>$DV_{DD} - 0.1$<br>$DV_{DD} - 1.5$<br>9<br>9<br>200 | $DV_{DD}$<br>$0.2 \cdot DV_{DD}$<br>+10<br>0.4<br>$DV_{DD}$ | V<br>V<br>$\mu A$<br>$\mu A$<br>V<br>V<br>V<br>V<br>k $\Omega$<br>k $\Omega$<br>k $\Omega$ |

# FLASH MEMORY CHARACTERISTICS: $DV_{DD} = 2.7V$ to $5.25V$

$t_{USEC} = 1\mu s$ ,  $t_{MSEC} = 1ms$

| PARAMETER                   | CONDITION                   | MSC1212Yx |           |     | UNITS   |
|-----------------------------|-----------------------------|-----------|-----------|-----|---------|
|                             |                             | MIN       | TYP       | MAX |         |
| Flash Memory Endurance      |                             | 100,000   | 1,000,000 |     | cycles  |
| Flash Memory Data Retention |                             | 100       |           |     | Years   |
| Mass and Page Erase Time    | Set with FER Value in FTCON | 10        |           |     | ms      |
| Flash Memory Data Retention | Set with FWR Value in FTCON | 30        |           | 40  | $\mu s$ |

# AC ELECTRICAL CHARACTERISTICS<sup>(1)(2)</sup>: $V_{DD} = 2.7V$ to $5.25V$

| SYMBOL                | FIGURE | PARAMETER  | 2.7V to 3.6V      |                             | 4.75V to 5.25V   |                             | UNITS |
|-----------------------|--------|--|-------------------|-----------------------------|------------------|-----------------------------|-------|
|                       |        |  | MIN               | MAX                         | MIN              | MAX                         |       |
| <b>System Clock</b>   |        |  |                   |                             |                  |                             |       |
| $f_{OSC}^{(3)}$       | D      | External Crystal Frequency ( $f_{OSC}$ )   | 1                 | 16                          | 1                | 30                          | MHz   |
| $1/t_{OSC}^{(3)}$     | D      | External Clock Frequency ( $f_{OSC}$ )   | 0                 | 16                          | 1                | 30                          | MHz   |
| $f_{OSC}^{(3)}$       | D      | External Ceramic Resonator Frequency ( $f_{OSC}$ )                                   | 1                 | 12                          | 1                | 12                          | MHz   |
| <b>Program Memory</b> |        |  |                   |                             |                  |                             |       |
| $t_{LHLL}$            | A      | ALE Pulse Width  | $1.5t_{CLK} - 5$  |                             | $1.5t_{CLK} - 5$ |                             | ns    |
| $t_{AVLL}$            | A      | Address Valid to ALE LOW   | $0.5t_{CLK} - 10$ |                             | $0.5t_{CLK} - 7$ |                             | ns    |
| $t_{LLAX}$            | A      | Address Hold After ALE LOW   | $0.5t_{CLK}$      |                             | $0.5t_{CLK}$     |                             | ns    |
| $t_{LLIV}$            | A      | ALE LOW to Valid Instruction In  |                   | $2.5t_{CLK} - 35$           |                  | $2.5t_{CLK} - 25$           | ns    |
| $t_{LLPL}$            | A      | ALE LOW to $\overline{PSEN}$ LOW   | $0.5t_{CLK}$      |                             | $0.5t_{CLK}$     |                             | ns    |
| $t_{PLPH}$            | A      | $\overline{PSEN}$ Pulse Width  | $2t_{CLK} - 5$    |                             | $2t_{CLK} - 5$   |                             | ns    |
| $t_{PLIV}$            | A      | $\overline{PSEN}$ LOW to Valid Instruction In  |                   | $2t_{CLK} - 40$             |                  | $2t_{CLK} - 30$             | ns    |
| $t_{PXIX}$            | A      | Input Instruction Hold After $\overline{PSEN}$                                       | 5                 |                             | -5               |                             | ns    |
| $t_{PXIZ}$            | A      | Input Instruction Float After $\overline{PSEN}$                                      |                   | $t_{CLK} - 5$               |                  | $t_{CLK}$                   | ns    |
| $t_{AVIV}$            | A      | Address to Valid Instruction In  |                   | $3t_{CLK} - 40$             |                  | $3t_{CLK} - 25$             | ns    |
| $t_{PLAZ}$            | A      | $\overline{PSEN}$ LOW to Address Float   |                   | 0                           |                  | 0                           | ns    |
| <b>Data Memory</b>    |        |  |                   |                             |                  |                             |       |
| $t_{RLRH}$            | B      | $\overline{RD}$ Pulse Width ( $t_{MCS} = 0$ ) <sup>(4)</sup>                         | $2t_{CLK} - 5$    |                             | $2t_{CLK} - 5$   |                             | ns    |
|                       | B      | $\overline{RD}$ Pulse Width ( $t_{MCS} > 0$ ) <sup>(4)</sup>                         | $t_{MCS} - 5$     |                             | $t_{MCS} - 5$    |                             | ns    |
| $t_{WLWH}$            | C      | $\overline{WR}$ Pulse Width ( $t_{MCS} = 0$ ) <sup>(4)</sup>                         | $2t_{CLK} - 5$    |                             | $2t_{CLK} - 5$   |                             | ns    |
|                       | C      | Pulse Width ( $t_{MCS} > 0$ ) <sup>(4)</sup>   | $t_{MCS} - 5$     |                             | $t_{MCS} - 5$    |                             | ns    |
| $t_{RLDV}$            | B      | $\overline{RD}$ LOW to Valid Data In ( $t_{MCS} = 0$ ) <sup>(4)</sup>                |                   | $2t_{CLK} - 40$             |                  | $2t_{CLK} - 30$             | ns    |
|                       | B      | $\overline{RD}$ LOW to Valid Data In ( $t_{MCS} > 0$ ) <sup>(4)</sup>                |                   | $t_{MCS} - 40$              |                  | $t_{MCS} - 30$              | ns    |
| $t_{RHDX}$            | B      | Data Hold After Read   | -5                |                             | -5               |                             | ns    |
| $t_{RHDZ}$            | B      | Data Float After Read ( $t_{MCS} = 0$ ) <sup>(4)</sup>                               |                   | $t_{CLK}$                   |                  | $t_{CLK}$                   | ns    |
|                       | B      | Data Float After Read ( $t_{MCS} > 0$ ) <sup>(4)</sup>                               |                   | $2t_{CLK}$                  |                  | $2t_{CLK}$                  | ns    |
| $t_{LLDV}$            | B      | ALE LOW to Valid Data In ( $t_{MCS} = 0$ ) <sup>(4)</sup>                            |                   | $2.5t_{CLK} - 40$           |                  | $2.5t_{CLK} - 25$           | ns    |
|                       | B      | ALE LOW to Valid Data In ( $t_{MCS} > 0$ ) <sup>(4)</sup>                            |                   | $t_{CLK} + t_{MCS} - 40$    |                  | $t_{CLK} + t_{MCS} - 25$    | ns    |
| $t_{AVDV}$            | B      | Address to Valid Data In ( $t_{MCS} = 0$ ) <sup>(4)</sup>                            |                   | $3t_{CLK} - 40$             |                  | $3t_{CLK} - 25$             | ns    |
|                       | B      | Address to Valid Data In ( $t_{MCS} > 0$ ) <sup>(4)</sup>                            |                   | $1.5t_{CLK} + t_{MCS} - 40$ |                  | $1.5t_{CLK} + t_{MCS} - 25$ | ns    |
| $t_{LLWL}$            | B, C   | ALE LOW to $\overline{RD}$ or $\overline{WR}$ LOW ( $t_{MCS} = 0$ ) <sup>(4)</sup>   | $0.5t_{CLK} - 5$  | $0.5t_{CLK} + 5$            | $0.5t_{CLK} - 5$ | $0.5t_{CLK} + 5$            | ns    |
|                       | B, C   | ALE LOW to $\overline{RD}$ or $\overline{WR}$ LOW ( $t_{MCS} > 0$ ) <sup>(4)</sup>   | $t_{CLK} - 5$     | $t_{CLK} + 5$               | $t_{CLK} - 5$    | $t_{CLK} + 5$               | ns    |
| $t_{AVWL}$            | B, C   | Address to $\overline{RD}$ or $\overline{WR}$ LOW ( $t_{MCS} = 0$ ) <sup>(4)</sup>   | $t_{CLK} - 5$     |                             | $t_{CLK} - 5$    |                             | ns    |
|                       | B, C   | Address to $\overline{RD}$ or $\overline{WR}$ LOW ( $t_{MCS} > 0$ ) <sup>(4)</sup>   | $2t_{CLK} - 5$    |                             | $2t_{CLK} - 5$   |                             | ns    |
| $t_{QVWX}$            | C      | Data Valid to $\overline{WR}$ Transition   | -8                |                             | -5               |                             | ns    |
| $t_{WHQX}$            | C      | Data Hold After $\overline{WR}$  | $t_{CLK} - 8$     |                             | $t_{CLK} - 5$    |                             | ns    |
| $t_{RLAZ}$            | B      | $\overline{RD}$ LOW to Address Float   |                   | $-0.5t_{CLK} - 5$           |                  | $-0.5t_{CLK} - 5$           | ns    |
| $t_{WHLH}$            | B, C   | $\overline{RD}$ or $\overline{WR}$ HIGH to ALE HIGH ( $t_{MCS} = 0$ ) <sup>(4)</sup> | -5                | 5                           | -5               | 5                           | ns    |
|                       | B, C   | $\overline{RD}$ or $\overline{WR}$ HIGH to ALE HIGH ( $t_{MCS} > 0$ ) <sup>(4)</sup> | $t_{CLK} - 5$     | $t_{CLK} + 5$               | $t_{CLK} - 5$    | $t_{CLK} + 5$               | ns    |
| <b>External Clock</b> |        |  |                   |                             |                  |                             |       |
| $t_{HIGH}$            | D      | HIGH Time <sup>(5)</sup>   | 15                |                             | 10               |                             | ns    |
| $t_{LOW}$             | D      | LOW Time <sup>(5)</sup>  | 15                |                             | 10               |                             | ns    |
| $t_R$                 | D      | Rise Time <sup>(5)</sup>   |                   | 5                           |                  | 5                           | ns    |
| $t_F$                 | D      | Fall Time <sup>(5)</sup>   |                   | 5                           |                  | 5                           | ns    |

NOTES: (1) Parameters are valid over operating temperature range, unless otherwise specified. (2) Load capacitance for Port 0, ALE, and  $\overline{PSEN} = 100pF$ , load capacitance for all other outputs =  $80pF$ . (3)  $t_{CLK} = 1/f_{OSC}$  = one oscillator clock period for clock divider = 1. (4)  $t_{MCS}$  is a time period related to the Stretch MOVX selection. The following table shows the value of  $t_{MCS}$  for each stretch selection. (5) These values are characterized but not 100% production tested.

| MD2 | MD1 | MD0 | MOVX DURATION              | $t_{MCS}$   |
|-----|-----|-----|----------------------------|-------------|
| 0   | 0   | 0   | 2 Machine Cycles           | 0           |
| 0   | 0   | 1   | 3 Machine Cycles (default) | $4t_{CLK}$  |
| 0   | 1   | 0   | 4 Machine Cycles           | $8t_{CLK}$  |
| 0   | 1   | 1   | 5 Machine Cycles           | $12t_{CLK}$ |
| 1   | 0   | 0   | 6 Machine Cycles           | $16t_{CLK}$ |
| 1   | 0   | 1   | 7 Machine Cycles           | $20t_{CLK}$ |
| 1   | 1   | 0   | 8 Machine Cycles           | $24t_{CLK}$ |
| 1   | 1   | 1   | 9 Machine Cycles           | $28t_{CLK}$ |

# EXPLANATION OF THE AC SYMBOLS

Each Timing Symbol has five characters. The first character is always 't' (= time). The other characters, depending on their positions, indicate the name of a signal or the logical status of that signal. The designators are:

- A—Address
- C—Clock
- D—Input Data
- H—Logic Level HIGH
- I—Instruction (program memory contents)
- L—Logic Level LOW, or ALE
- P— $\overline{\text{PSEN}}$
- Q—Output Data

- R— $\overline{\text{RD}}$  Signal
- t—Time
- V—Valid
- W— $\overline{\text{WR}}$  Signal
- X—No Longer a Valid Logic Level
- Z—Float

Examples: (1)  $t_{\text{AVLL}}$  = Time for address valid to ALE LOW. (2)  $t_{\text{LLPL}}$  = Time for ALE LOW to  $\overline{\text{PSEN}}$  LOW.

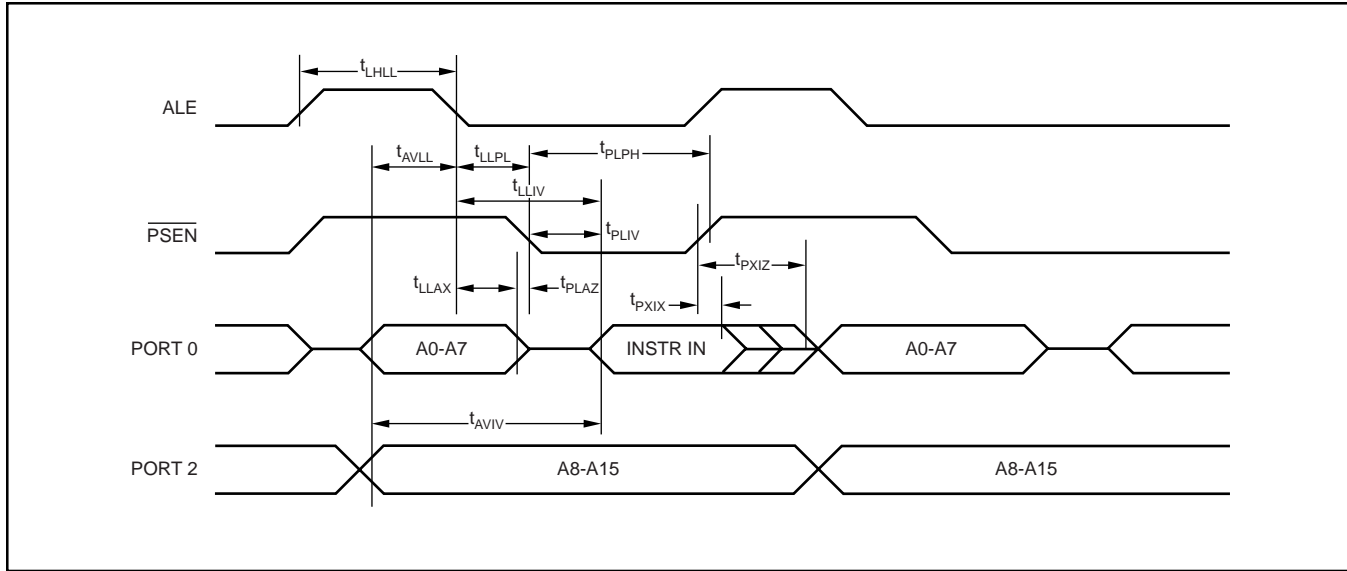

FIGURE A. External Program Memory Read Cycle.

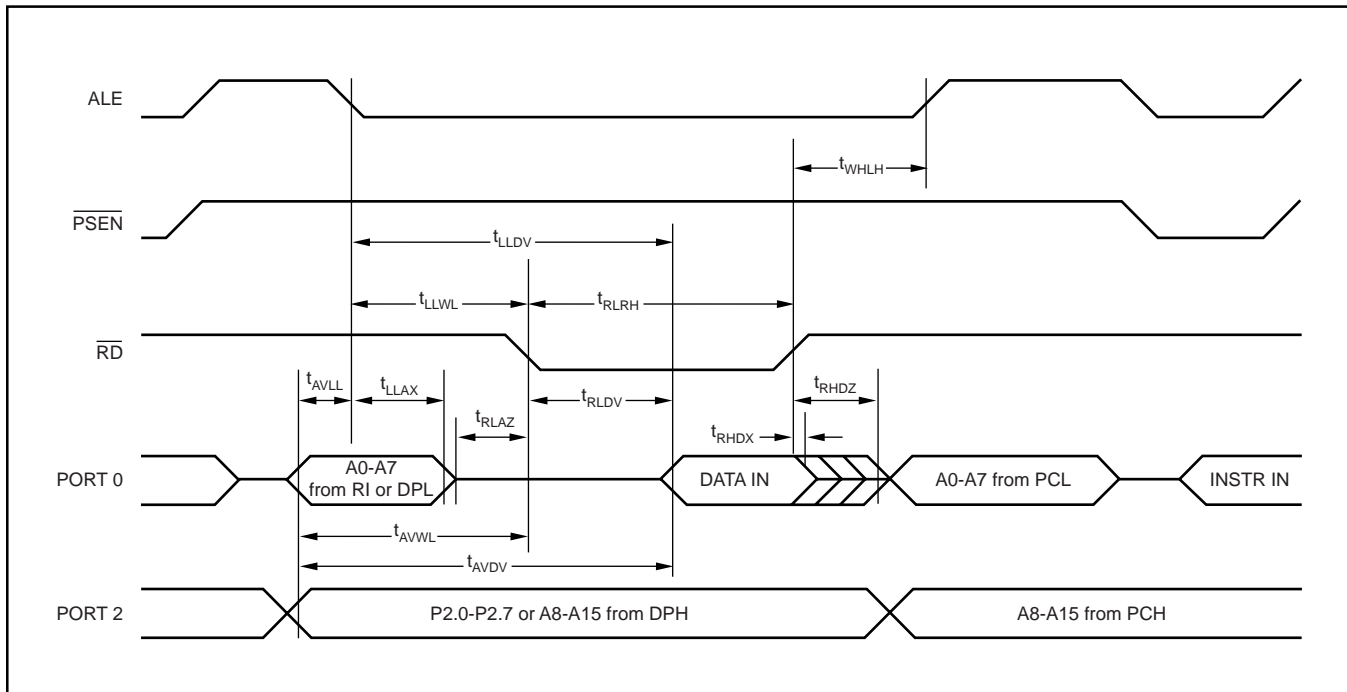

FIGURE B. External Data Memory Read Cycle.

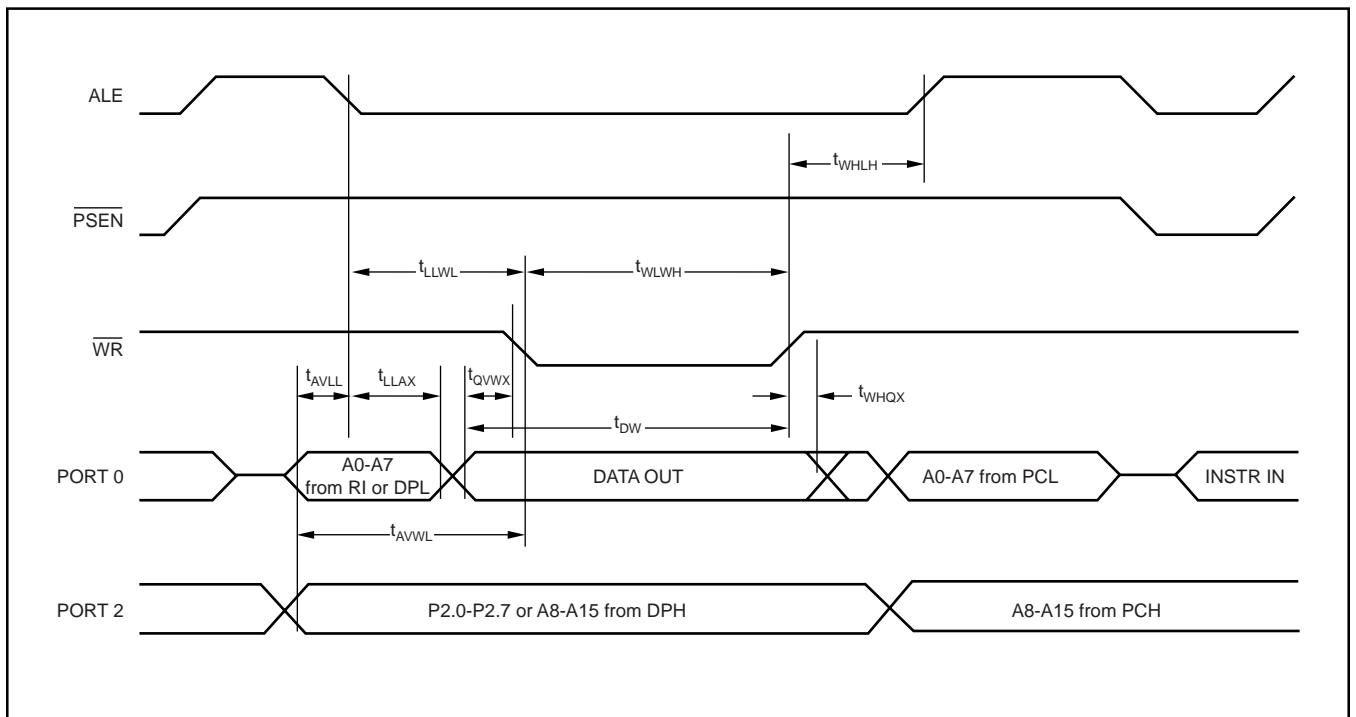

FIGURE C. External Data Memory Write Cycle.

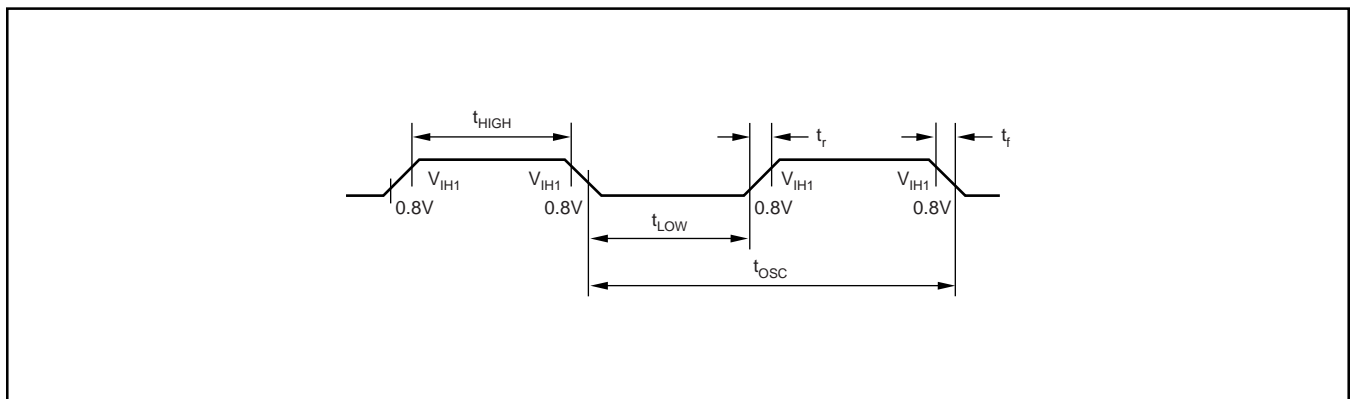

FIGURE D. External Clock Drive CLK.

## RESET AND POWER-ON TIMING

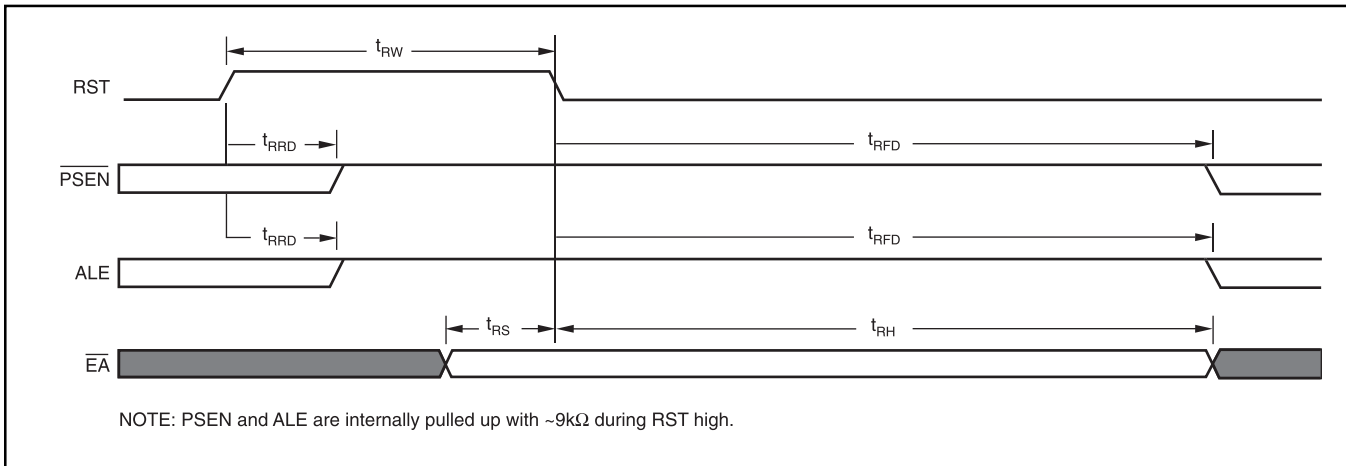

FIGURE E. Reset Timing.

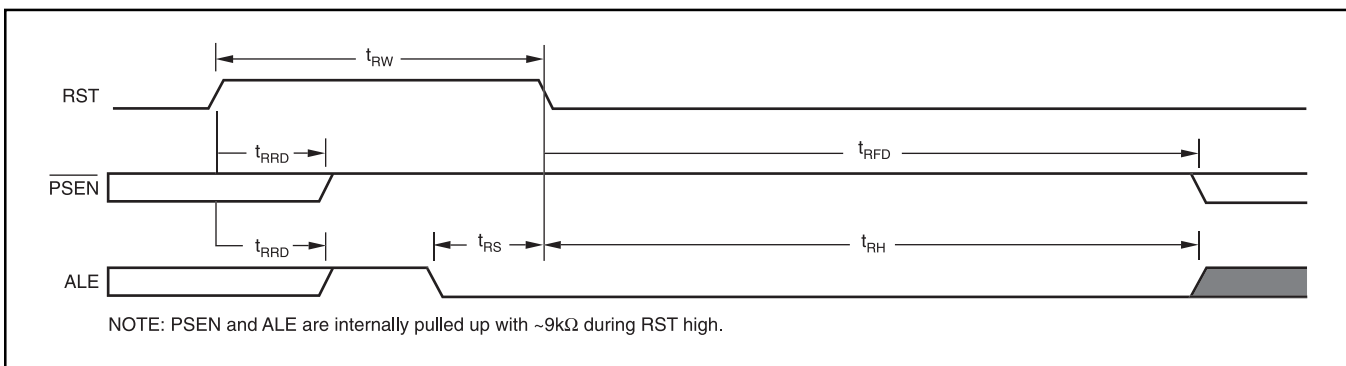

FIGURE F. Parallel Flash Programming Power-On Timing ( $\overline{EA}$  is ignored).

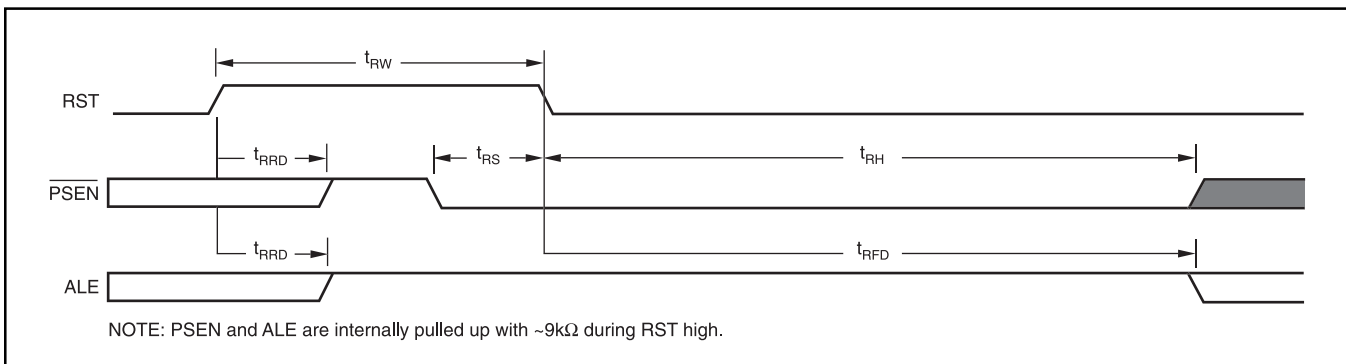
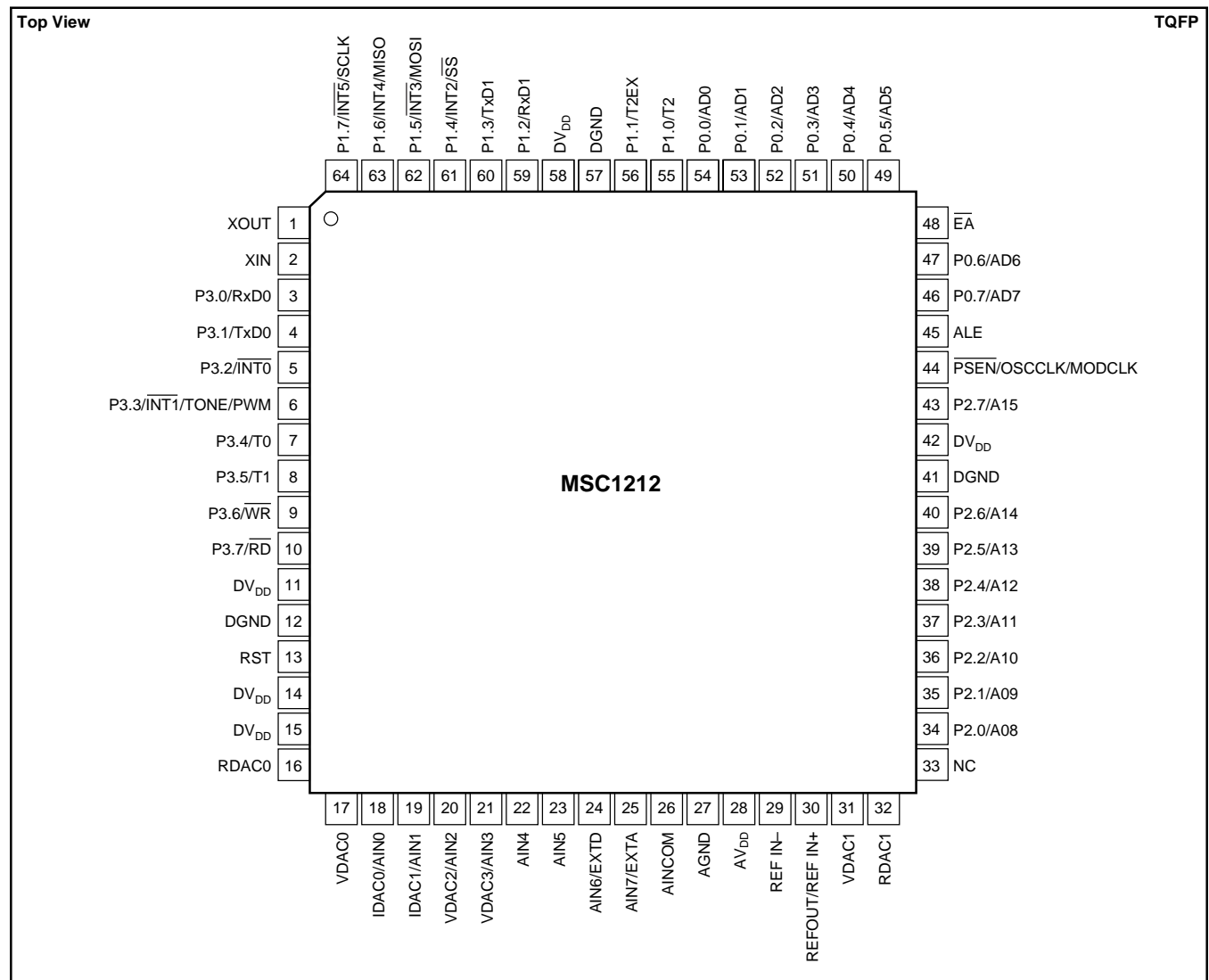

FIGURE G. Serial Flash Programming Power-On Timing ( $\overline{EA}$  is ignored).

| SYMBOL    | PARAMETER  | MIN                      | MAX                      | UNIT    |
|-----------|--|--------------------------|--------------------------|---------|
| $t_{RW}$  | RST width  | $2 t_{osc}$              | —                        | ns      |
| $t_{RRD}$ | RST rise to $\overline{PSEN}$ ALE internal pull high | —                        | 5                        | $\mu s$ |
| $t_{RFD}$ | RST falling to $\overline{PSEN}$ and ALE start       | —                        | $(2^{17} + 512) t_{osc}$ | ns      |
| $t_{RS}$  | Input signal to RST falling setup time               | $t_{osc}$                | —                        | ns      |
| $t_{RH}$  | RST falling to input signal hold time                | $(2^{17} + 512) t_{osc}$ | —                        | ns      |

## PIN CONFIGURATION



## PIN DESCRIPTIONS

| PIN #              | NAME                               | DESCRIPTION  |      |           |      |      |      |                     |      |      |                      |      |                          |                      |      |                                    |                                      |      |    |                        |      |    |                        |      |                        |                                   |      |                        |                                  |
|--------------------|------------------------------------|--|------|-----------|------|------|------|---------------------|------|------|----------------------|------|--------------------------|----------------------|------|------------------------------------|--------------------------------------|------|----|------------------------|------|----|------------------------|------|------------------------|-----------------------------------|------|------------------------|----------------------------------|
| 1                  | XOUT                               | The crystal oscillator pin XOUT supports parallel resonant AT cut crystals and ceramic resonators. XOUT serves as the output of the crystal amplifier.   |      |           |      |      |      |                     |      |      |                      |      |                          |                      |      |                                    |                                      |      |    |                        |      |    |                        |      |                        |                                   |      |                        |                                  |
| 2                  | XIN                                | The crystal oscillator pin XIN supports parallel resonant AT cut crystals and ceramic resonators. XIN can also be an input if there is an external clock source instead of a crystal.  |      |           |      |      |      |                     |      |      |                      |      |                          |                      |      |                                    |                                      |      |    |                        |      |    |                        |      |                        |                                   |      |                        |                                  |
| 3-10               | P3.0-P3.7                          | Port 3 is a bidirectional I/O port. The alternate functions for Port 3 are listed below.<br>Port 3—Alternate Functions:  |      |           |      |      |      |                     |      |      |                      |      |                          |                      |      |                                    |                                      |      |    |                        |      |    |                        |      |                        |                                   |      |                        |                                  |
|                    |                                    | <table border="1"> <thead> <tr> <th>PORT</th> <th>ALTERNATE</th> <th>MODE</th> </tr> </thead> <tbody> <tr> <td>P3.0</td> <td>RxD0</td> <td>Serial Port 0 Input</td> </tr> <tr> <td>P3.1</td> <td>TxD0</td> <td>Serial Port 0 Output</td> </tr> <tr> <td>P3.2</td> <td><math>\overline{\text{INT0}}</math></td> <td>External Interrupt 0</td> </tr> <tr> <td>P3.3</td> <td><math>\overline{\text{INT1}}</math>/TONE/PWM</td> <td>External Interrupt 1/TONE/PWM Output</td> </tr> <tr> <td>P3.4</td> <td>T0</td> <td>Timer 0 External Input</td> </tr> <tr> <td>P3.5</td> <td>T1</td> <td>Timer 1 External Input</td> </tr> <tr> <td>P3.6</td> <td><math>\overline{\text{WR}}</math></td> <td>External Data Memory Write Strobe</td> </tr> <tr> <td>P3.7</td> <td><math>\overline{\text{RD}}</math></td> <td>External Data Memory Read Strobe</td> </tr> </tbody> </table> | PORT | ALTERNATE | MODE | P3.0 | RxD0 | Serial Port 0 Input | P3.1 | TxD0 | Serial Port 0 Output | P3.2 | $\overline{\text{INT0}}$ | External Interrupt 0 | P3.3 | $\overline{\text{INT1}}$ /TONE/PWM | External Interrupt 1/TONE/PWM Output | P3.4 | T0 | Timer 0 External Input | P3.5 | T1 | Timer 1 External Input | P3.6 | $\overline{\text{WR}}$ | External Data Memory Write Strobe | P3.7 | $\overline{\text{RD}}$ | External Data Memory Read Strobe |
| PORT               | ALTERNATE                          | MODE   |      |           |      |      |      |                     |      |      |                      |      |                          |                      |      |                                    |                                      |      |    |                        |      |    |                        |      |                        |                                   |      |                        |                                  |
| P3.0               | RxD0                               | Serial Port 0 Input  |      |           |      |      |      |                     |      |      |                      |      |                          |                      |      |                                    |                                      |      |    |                        |      |    |                        |      |                        |                                   |      |                        |                                  |
| P3.1               | TxD0                               | Serial Port 0 Output   |      |           |      |      |      |                     |      |      |                      |      |                          |                      |      |                                    |                                      |      |    |                        |      |    |                        |      |                        |                                   |      |                        |                                  |
| P3.2               | $\overline{\text{INT0}}$           | External Interrupt 0   |      |           |      |      |      |                     |      |      |                      |      |                          |                      |      |                                    |                                      |      |    |                        |      |    |                        |      |                        |                                   |      |                        |                                  |
| P3.3               | $\overline{\text{INT1}}$ /TONE/PWM | External Interrupt 1/TONE/PWM Output   |      |           |      |      |      |                     |      |      |                      |      |                          |                      |      |                                    |                                      |      |    |                        |      |    |                        |      |                        |                                   |      |                        |                                  |
| P3.4               | T0                                 | Timer 0 External Input   |      |           |      |      |      |                     |      |      |                      |      |                          |                      |      |                                    |                                      |      |    |                        |      |    |                        |      |                        |                                   |      |                        |                                  |
| P3.5               | T1                                 | Timer 1 External Input   |      |           |      |      |      |                     |      |      |                      |      |                          |                      |      |                                    |                                      |      |    |                        |      |    |                        |      |                        |                                   |      |                        |                                  |
| P3.6               | $\overline{\text{WR}}$             | External Data Memory Write Strobe  |      |           |      |      |      |                     |      |      |                      |      |                          |                      |      |                                    |                                      |      |    |                        |      |    |                        |      |                        |                                   |      |                        |                                  |
| P3.7               | $\overline{\text{RD}}$             | External Data Memory Read Strobe   |      |           |      |      |      |                     |      |      |                      |      |                          |                      |      |                                    |                                      |      |    |                        |      |    |                        |      |                        |                                   |      |                        |                                  |
| 11, 14, 15, 42, 58 | DV <sub>DD</sub>                   | Digital Power Supply   |      |           |      |      |      |                     |      |      |                      |      |                          |                      |      |                                    |                                      |      |    |                        |      |    |                        |      |                        |                                   |      |                        |                                  |
| 12, 41, 57         | DGND                               | Digital Ground   |      |           |      |      |      |                     |      |      |                      |      |                          |                      |      |                                    |                                      |      |    |                        |      |    |                        |      |                        |                                   |      |                        |                                  |
| 13                 | RST                                | A HIGH on the reset input for two t <sub>OSC</sub> periods will reset the device.  |      |           |      |      |      |                     |      |      |                      |      |                          |                      |      |                                    |                                      |      |    |                        |      |    |                        |      |                        |                                   |      |                        |                                  |
| 16                 | RDAC0                              | RDAC0 Output   |      |           |      |      |      |                     |      |      |                      |      |                          |                      |      |                                    |                                      |      |    |                        |      |    |                        |      |                        |                                   |      |                        |                                  |
| 17                 | VDAC0                              | VDAC0 Output   |      |           |      |      |      |                     |      |      |                      |      |                          |                      |      |                                    |                                      |      |    |                        |      |    |                        |      |                        |                                   |      |                        |                                  |
| 27                 | AGND                               | Analog Ground  |      |           |      |      |      |                     |      |      |                      |      |                          |                      |      |                                    |                                      |      |    |                        |      |    |                        |      |                        |                                   |      |                        |                                  |
| 18                 | IDAC0/AIN0                         | IDAC0 Output/Analog Input Channel 0  |      |           |      |      |      |                     |      |      |                      |      |                          |                      |      |                                    |                                      |      |    |                        |      |    |                        |      |                        |                                   |      |                        |                                  |
| 19                 | IDAC1/AIN1                         | IDAC1 Output/Analog Input Channel 1  |      |           |      |      |      |                     |      |      |                      |      |                          |                      |      |                                    |                                      |      |    |                        |      |    |                        |      |                        |                                   |      |                        |                                  |

## PIN DESCRIPTIONS (Cont.)

| PIN #   | NAME   | DESCRIPTION  |      |                          |                                     |      |     |  |      |      |                      |      |      |                    |      |      |                    |      |                             |                                 |      |                               |  |      |                               |  |      |                               |                                 |
|---|--|--|------|--------------------------|-------------------------------------|------|-----|--|------|------|----------------------|------|------|--------------------|------|------|--------------------|------|-----------------------------|---------------------------------|------|-------------------------------|--|------|-------------------------------|--|------|-------------------------------|---------------------------------|
| 20  | VDAC2/AIN2                                   | VDAC2 Output/Analog Input Channel 2  |      |                          |                                     |      |     |  |      |      |                      |      |      |                    |      |      |                    |      |                             |                                 |      |                               |  |      |                               |  |      |                               |                                 |
| 21  | VDAC3/AIN3                                   | VDAC3 Output/Analog Input Channel 3  |      |                          |                                     |      |     |  |      |      |                      |      |      |                    |      |      |                    |      |                             |                                 |      |                               |  |      |                               |  |      |                               |                                 |
| 22  | AIN4   | Analog Input Channel 4   |      |                          |                                     |      |     |  |      |      |                      |      |      |                    |      |      |                    |      |                             |                                 |      |                               |  |      |                               |  |      |                               |                                 |
| 23  | AIN5   | Analog Input Channel 5   |      |                          |                                     |      |     |  |      |      |                      |      |      |                    |      |      |                    |      |                             |                                 |      |                               |  |      |                               |  |      |                               |                                 |
| 24  | AIN6, EXT <sub>D</sub>                       | Analog Input Channel 6, Low Voltage Detect Input Generates DLVD Interrupt  |      |                          |                                     |      |     |  |      |      |                      |      |      |                    |      |      |                    |      |                             |                                 |      |                               |  |      |                               |  |      |                               |                                 |
| 25  | AIN7, EXT <sub>A</sub>                       | Analog Input Channel 7, Low Voltage Detect Input Generates ALVD Interrupt  |      |                          |                                     |      |     |  |      |      |                      |      |      |                    |      |      |                    |      |                             |                                 |      |                               |  |      |                               |  |      |                               |                                 |
| 26  | AINCOM                                       | Analog Common for Single-Ended Inputs  |      |                          |                                     |      |     |  |      |      |                      |      |      |                    |      |      |                    |      |                             |                                 |      |                               |  |      |                               |  |      |                               |                                 |
| 28  | AV <sub>DD</sub>                             | Analog Power Supply  |      |                          |                                     |      |     |  |      |      |                      |      |      |                    |      |      |                    |      |                             |                                 |      |                               |  |      |                               |  |      |                               |                                 |
| 29  | REF IN <sup>-</sup>                          | Voltage Reference Negative Input   |      |                          |                                     |      |     |  |      |      |                      |      |      |                    |      |      |                    |      |                             |                                 |      |                               |  |      |                               |  |      |                               |                                 |
| 30  | REFOUT/REF IN <sup>+</sup>                   | Voltage Reference Output/ Voltage Reference Positive Input   |      |                          |                                     |      |     |  |      |      |                      |      |      |                    |      |      |                    |      |                             |                                 |      |                               |  |      |                               |  |      |                               |                                 |
| 31  | VDAC1  | VDAC1 Output   |      |                          |                                     |      |     |  |      |      |                      |      |      |                    |      |      |                    |      |                             |                                 |      |                               |  |      |                               |  |      |                               |                                 |
| 32  | RDAC1  | RDAC1 Output   |      |                          |                                     |      |     |  |      |      |                      |      |      |                    |      |      |                    |      |                             |                                 |      |                               |  |      |                               |  |      |                               |                                 |
| 33  | NC   | No Connection  |      |                          |                                     |      |     |  |      |      |                      |      |      |                    |      |      |                    |      |                             |                                 |      |                               |  |      |                               |  |      |                               |                                 |
| 34-40, 43   | P2.0-P2.7                                    | Port 2 is a bidirectional I/O port. The alternate functions for Port 2 are listed below.<br>Port 2—Alternate Functions:  |      |                          |                                     |      |     |  |      |      |                      |      |      |                    |      |      |                    |      |                             |                                 |      |                               |  |      |                               |  |      |                               |                                 |
| <table border="1"> <thead> <tr> <th>PORT</th> <th>ALTERNATE</th> <th>MODE</th> </tr> </thead> <tbody> <tr> <td>P2.0</td> <td>A8</td> <td>Address Bit 8</td> </tr> <tr> <td>P2.1</td> <td>A9</td> <td>Address Bit 9</td> </tr> <tr> <td>P2.2</td> <td>A10</td> <td>Address Bit 10</td> </tr> <tr> <td>P2.3</td> <td>A11</td> <td>Address Bit 11</td> </tr> <tr> <td>P2.4</td> <td>A12</td> <td>Address Bit 12</td> </tr> <tr> <td>P2.5</td> <td>A13</td> <td>Address Bit 13</td> </tr> <tr> <td>P2.6</td> <td>A14</td> <td>Address Bit 14</td> </tr> <tr> <td>P2.7</td> <td>A15</td> <td>Address Bit 15</td> </tr> </tbody> </table>   |  |  | PORT | ALTERNATE                | MODE                                | P2.0 | A8  | Address Bit 8                            | P2.1 | A9   | Address Bit 9        | P2.2 | A10  | Address Bit 10     | P2.3 | A11  | Address Bit 11     | P2.4 | A12                         | Address Bit 12                  | P2.5 | A13                           | Address Bit 13                         | P2.6 | A14                           | Address Bit 14                         | P2.7 | A15                           | Address Bit 15                  |
| PORT  | ALTERNATE                                    | MODE   |      |                          |                                     |      |     |  |      |      |                      |      |      |                    |      |      |                    |      |                             |                                 |      |                               |  |      |                               |  |      |                               |                                 |
| P2.0  | A8   | Address Bit 8  |      |                          |                                     |      |     |  |      |      |                      |      |      |                    |      |      |                    |      |                             |                                 |      |                               |  |      |                               |  |      |                               |                                 |
| P2.1  | A9   | Address Bit 9  |      |                          |                                     |      |     |  |      |      |                      |      |      |                    |      |      |                    |      |                             |                                 |      |                               |  |      |                               |  |      |                               |                                 |
| P2.2  | A10  | Address Bit 10   |      |                          |                                     |      |     |  |      |      |                      |      |      |                    |      |      |                    |      |                             |                                 |      |                               |  |      |                               |  |      |                               |                                 |
| P2.3  | A11  | Address Bit 11   |      |                          |                                     |      |     |  |      |      |                      |      |      |                    |      |      |                    |      |                             |                                 |      |                               |  |      |                               |  |      |                               |                                 |
| P2.4  | A12  | Address Bit 12   |      |                          |                                     |      |     |  |      |      |                      |      |      |                    |      |      |                    |      |                             |                                 |      |                               |  |      |                               |  |      |                               |                                 |
| P2.5  | A13  | Address Bit 13   |      |                          |                                     |      |     |  |      |      |                      |      |      |                    |      |      |                    |      |                             |                                 |      |                               |  |      |                               |  |      |                               |                                 |
| P2.6  | A14  | Address Bit 14   |      |                          |                                     |      |     |  |      |      |                      |      |      |                    |      |      |                    |      |                             |                                 |      |                               |  |      |                               |  |      |                               |                                 |
| P2.7  | A15  | Address Bit 15   |      |                          |                                     |      |     |  |      |      |                      |      |      |                    |      |      |                    |      |                             |                                 |      |                               |  |      |                               |  |      |                               |                                 |
| 44  | $\overline{\text{PSEN}}$<br>OSCCLK<br>MODCLK | Program Store Enable: Connected to optional external memory as a chip enable. $\overline{\text{PSEN}}$ will provide an active low pulse. In programming mode, $\overline{\text{PSEN}}$ is used as an input along with ALE to define serial or parallel programming mode. $\overline{\text{PSEN}}$ is held HIGH for parallel programming and tied LOW for serial programming. This pin can also be selected (when not using external memory) to output the Oscillator clock, Modulator clock, HIGH, or LOW for light loads.   |      |                          |                                     |      |     |  |      |      |                      |      |      |                    |      |      |                    |      |                             |                                 |      |                               |  |      |                               |  |      |                               |                                 |
| <table border="1"> <thead> <tr> <th>ALE</th> <th><math>\overline{\text{PSEN}}</math></th> <th>PROGRAM MODE SELECTION DURING RESET</th> </tr> </thead> <tbody> <tr> <td>NC</td> <td>NC</td> <td>Normal Operation (user application mode)</td> </tr> <tr> <td>0</td> <td>NC</td> <td>Parallel Programming</td> </tr> <tr> <td>NC</td> <td>0</td> <td>Serial Programming</td> </tr> <tr> <td>0</td> <td>0</td> <td>Reserved</td> </tr> </tbody> </table>   |  |  | ALE  | $\overline{\text{PSEN}}$ | PROGRAM MODE SELECTION DURING RESET | NC   | NC  | Normal Operation (user application mode) | 0    | NC   | Parallel Programming | NC   | 0    | Serial Programming | 0    | 0    | Reserved           |      |                             |                                 |      |                               |  |      |                               |  |      |                               |                                 |
| ALE   | $\overline{\text{PSEN}}$                     | PROGRAM MODE SELECTION DURING RESET  |      |                          |                                     |      |     |  |      |      |                      |      |      |                    |      |      |                    |      |                             |                                 |      |                               |  |      |                               |  |      |                               |                                 |
| NC  | NC   | Normal Operation (user application mode)   |      |                          |                                     |      |     |  |      |      |                      |      |      |                    |      |      |                    |      |                             |                                 |      |                               |  |      |                               |  |      |                               |                                 |
| 0   | NC   | Parallel Programming   |      |                          |                                     |      |     |  |      |      |                      |      |      |                    |      |      |                    |      |                             |                                 |      |                               |  |      |                               |  |      |                               |                                 |
| NC  | 0  | Serial Programming   |      |                          |                                     |      |     |  |      |      |                      |      |      |                    |      |      |                    |      |                             |                                 |      |                               |  |      |                               |  |      |                               |                                 |
| 0   | 0  | Reserved   |      |                          |                                     |      |     |  |      |      |                      |      |      |                    |      |      |                    |      |                             |                                 |      |                               |  |      |                               |  |      |                               |                                 |
| 45  | ALE  | Address Latch Enable: Used for latching the low byte of the address during an access to external memory. ALE is emitted at a constant rate of 1/2 the oscillator frequency, and can be used for external timing or clocking. One ALE pulse is skipped during each access to external data memory. In programming mode, ALE is used as an input along with $\overline{\text{PSEN}}$ to define serial or parallel programming mode. ALE is held HIGH for serial programming and tied LOW for parallel programming. This pin can also be selected (when not using external memory) to output HIGH or LOW for light loads. |      |                          |                                     |      |     |  |      |      |                      |      |      |                    |      |      |                    |      |                             |                                 |      |                               |  |      |                               |  |      |                               |                                 |
| 48  | $\overline{\text{EA}}$                       | External Access Enable: $\overline{\text{EA}}$ must be externally held LOW to enable the device to fetch code from external program memory locations starting with 0000 <sub>H</sub> .   |      |                          |                                     |      |     |  |      |      |                      |      |      |                    |      |      |                    |      |                             |                                 |      |                               |  |      |                               |  |      |                               |                                 |
| 46, 47, 49-54   | P0.0-P0.7                                    | Port 0 is a bidirectional I/O port. The alternate functions for Port 0 are listed below.<br>Port 0—Alternate Functions:  |      |                          |                                     |      |     |  |      |      |                      |      |      |                    |      |      |                    |      |                             |                                 |      |                               |  |      |                               |  |      |                               |                                 |
| <table border="1"> <thead> <tr> <th>PORT</th> <th>ALTERNATE</th> <th>MODE</th> </tr> </thead> <tbody> <tr> <td>P0.0</td> <td>AD0</td> <td>Address/Data Bit 0</td> </tr> <tr> <td>P0.1</td> <td>AD1</td> <td>Address/Data Bit 1</td> </tr> <tr> <td>P0.2</td> <td>AD2</td> <td>Address/Data Bit 2</td> </tr> <tr> <td>P0.3</td> <td>AD3</td> <td>Address/Data Bit 3</td> </tr> <tr> <td>P0.4</td> <td>AD4</td> <td>Address/Data Bit 4</td> </tr> <tr> <td>P0.5</td> <td>AD5</td> <td>Address/Data Bit 5</td> </tr> <tr> <td>P0.6</td> <td>AD6</td> <td>Address/Data Bit 6</td> </tr> <tr> <td>P0.7</td> <td>AD7</td> <td>Address/Data Bit 7</td> </tr> </tbody> </table>   |  |  | PORT | ALTERNATE                | MODE                                | P0.0 | AD0 | Address/Data Bit 0                       | P0.1 | AD1  | Address/Data Bit 1   | P0.2 | AD2  | Address/Data Bit 2 | P0.3 | AD3  | Address/Data Bit 3 | P0.4 | AD4                         | Address/Data Bit 4              | P0.5 | AD5                           | Address/Data Bit 5                     | P0.6 | AD6                           | Address/Data Bit 6                     | P0.7 | AD7                           | Address/Data Bit 7              |
| PORT  | ALTERNATE                                    | MODE   |      |                          |                                     |      |     |  |      |      |                      |      |      |                    |      |      |                    |      |                             |                                 |      |                               |  |      |                               |  |      |                               |                                 |
| P0.0  | AD0  | Address/Data Bit 0   |      |                          |                                     |      |     |  |      |      |                      |      |      |                    |      |      |                    |      |                             |                                 |      |                               |  |      |                               |  |      |                               |                                 |
| P0.1  | AD1  | Address/Data Bit 1   |      |                          |                                     |      |     |  |      |      |                      |      |      |                    |      |      |                    |      |                             |                                 |      |                               |  |      |                               |  |      |                               |                                 |
| P0.2  | AD2  | Address/Data Bit 2   |      |                          |                                     |      |     |  |      |      |                      |      |      |                    |      |      |                    |      |                             |                                 |      |                               |  |      |                               |  |      |                               |                                 |
| P0.3  | AD3  | Address/Data Bit 3   |      |                          |                                     |      |     |  |      |      |                      |      |      |                    |      |      |                    |      |                             |                                 |      |                               |  |      |                               |  |      |                               |                                 |
| P0.4  | AD4  | Address/Data Bit 4   |      |                          |                                     |      |     |  |      |      |                      |      |      |                    |      |      |                    |      |                             |                                 |      |                               |  |      |                               |  |      |                               |                                 |
| P0.5  | AD5  | Address/Data Bit 5   |      |                          |                                     |      |     |  |      |      |                      |      |      |                    |      |      |                    |      |                             |                                 |      |                               |  |      |                               |  |      |                               |                                 |
| P0.6  | AD6  | Address/Data Bit 6   |      |                          |                                     |      |     |  |      |      |                      |      |      |                    |      |      |                    |      |                             |                                 |      |                               |  |      |                               |  |      |                               |                                 |
| P0.7  | AD7  | Address/Data Bit 7   |      |                          |                                     |      |     |  |      |      |                      |      |      |                    |      |      |                    |      |                             |                                 |      |                               |  |      |                               |  |      |                               |                                 |
| 55, 56, 59-64   | P1.0-P1.7                                    | Port 1 is a bidirectional I/O port. The alternate functions for Port 1 are listed below.<br>Port 1—Alternate Functions:  |      |                          |                                     |      |     |  |      |      |                      |      |      |                    |      |      |                    |      |                             |                                 |      |                               |  |      |                               |  |      |                               |                                 |
| <table border="1"> <thead> <tr> <th>PORT</th> <th>ALTERNATE</th> <th>MODE</th> </tr> </thead> <tbody> <tr> <td>P1.0</td> <td>T2</td> <td>T2 Input</td> </tr> <tr> <td>P1.1</td> <td>T2EX</td> <td>T2 External Input</td> </tr> <tr> <td>P1.2</td> <td>RxD1</td> <td>Serial Port Input</td> </tr> <tr> <td>P1.3</td> <td>TxD1</td> <td>Serial Port Output</td> </tr> <tr> <td>P1.4</td> <td><math>\overline{\text{INT2/SS}}</math></td> <td>External Interrupt/Slave Select</td> </tr> <tr> <td>P1.5</td> <td><math>\overline{\text{INT3/MOSI}}</math></td> <td>External Interrupt/Master Out-Slave In</td> </tr> <tr> <td>P1.6</td> <td><math>\overline{\text{INT4/MISO}}</math></td> <td>External Interrupt/Master In-Slave Out</td> </tr> <tr> <td>P1.7</td> <td><math>\overline{\text{INT5/SCLK}}</math></td> <td>External Interrupt/Serial Clock</td> </tr> </tbody> </table> |  |  | PORT | ALTERNATE                | MODE                                | P1.0 | T2  | T2 Input                                 | P1.1 | T2EX | T2 External Input    | P1.2 | RxD1 | Serial Port Input  | P1.3 | TxD1 | Serial Port Output | P1.4 | $\overline{\text{INT2/SS}}$ | External Interrupt/Slave Select | P1.5 | $\overline{\text{INT3/MOSI}}$ | External Interrupt/Master Out-Slave In | P1.6 | $\overline{\text{INT4/MISO}}$ | External Interrupt/Master In-Slave Out | P1.7 | $\overline{\text{INT5/SCLK}}$ | External Interrupt/Serial Clock |
| PORT  | ALTERNATE                                    | MODE   |      |                          |                                     |      |     |  |      |      |                      |      |      |                    |      |      |                    |      |                             |                                 |      |                               |  |      |                               |  |      |                               |                                 |
| P1.0  | T2   | T2 Input   |      |                          |                                     |      |     |  |      |      |                      |      |      |                    |      |      |                    |      |                             |                                 |      |                               |  |      |                               |  |      |                               |                                 |
| P1.1  | T2EX   | T2 External Input  |      |                          |                                     |      |     |  |      |      |                      |      |      |                    |      |      |                    |      |                             |                                 |      |                               |  |      |                               |  |      |                               |                                 |
| P1.2  | RxD1   | Serial Port Input  |      |                          |                                     |      |     |  |      |      |                      |      |      |                    |      |      |                    |      |                             |                                 |      |                               |  |      |                               |  |      |                               |                                 |
| P1.3  | TxD1   | Serial Port Output   |      |                          |                                     |      |     |  |      |      |                      |      |      |                    |      |      |                    |      |                             |                                 |      |                               |  |      |                               |  |      |                               |                                 |
| P1.4  | $\overline{\text{INT2/SS}}$                  | External Interrupt/Slave Select  |      |                          |                                     |      |     |  |      |      |                      |      |      |                    |      |      |                    |      |                             |                                 |      |                               |  |      |                               |  |      |                               |                                 |
| P1.5  | $\overline{\text{INT3/MOSI}}$                | External Interrupt/Master Out-Slave In   |      |                          |                                     |      |     |  |      |      |                      |      |      |                    |      |      |                    |      |                             |                                 |      |                               |  |      |                               |  |      |                               |                                 |
| P1.6  | $\overline{\text{INT4/MISO}}$                | External Interrupt/Master In-Slave Out   |      |                          |                                     |      |     |  |      |      |                      |      |      |                    |      |      |                    |      |                             |                                 |      |                               |  |      |                               |  |      |                               |                                 |
| P1.7  | $\overline{\text{INT5/SCLK}}$                | External Interrupt/Serial Clock  |      |                          |                                     |      |     |  |      |      |                      |      |      |                    |      |      |                    |      |                             |                                 |      |                               |  |      |                               |  |      |                               |                                 |

# TYPICAL CHARACTERISTICS

$AV_{DD} = +5V$ ,  $DV_{DD} = +5V$ ,  $f_{OSC} = 8MHz$ ,  $PGA = 1$ ,  $f_{MOD} = 15.625kHz$ , Bipolar, Buffer On, and  $V_{REF} \equiv (REF\ IN+) - (REF\ IN-) = +2.5V$ , unless otherwise specified. For  $V_{DAC}$ ,  $V_{REF} = AV_{DD}$ ,  $R_{LOAD} = 10k\Omega$ , and  $C_{LOAD} = 200pF$ , unless otherwise noted.

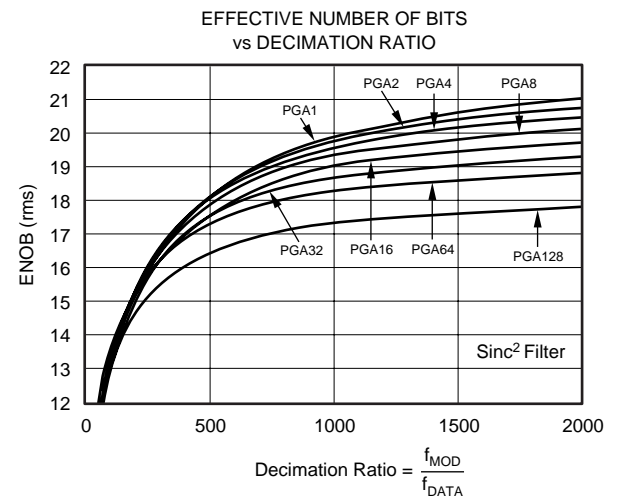
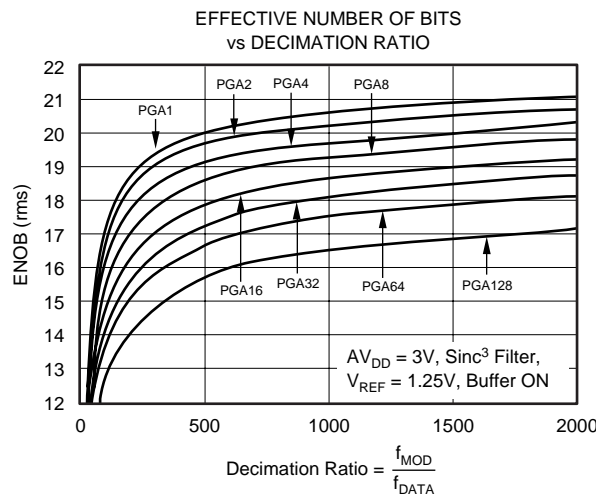
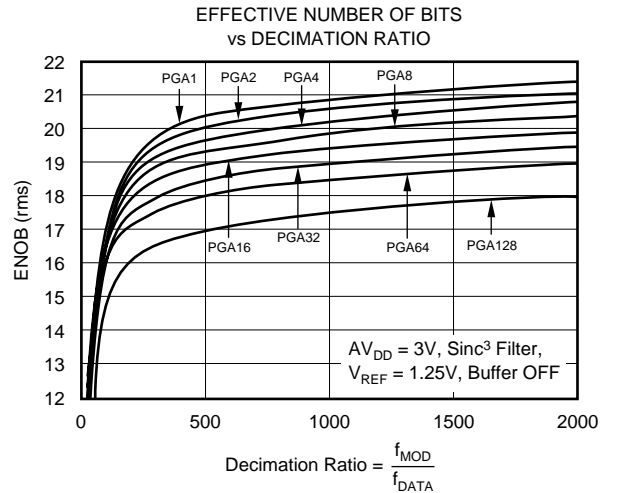
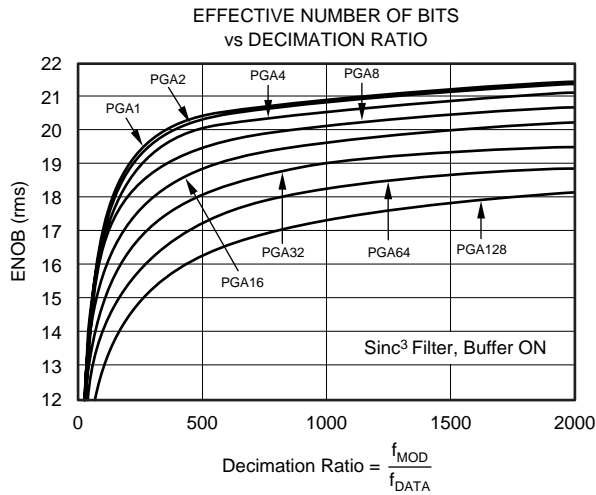
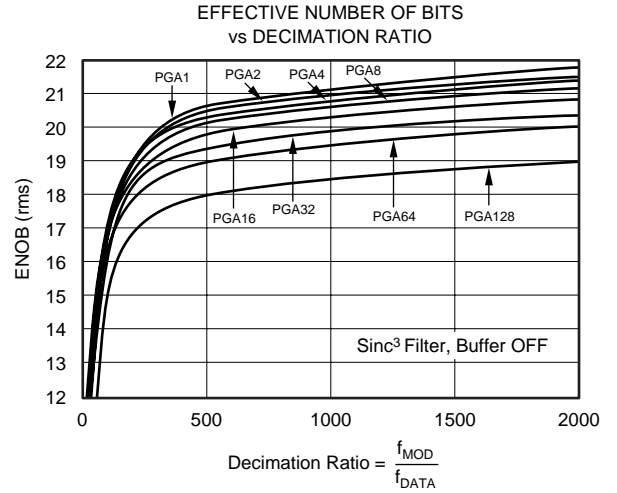
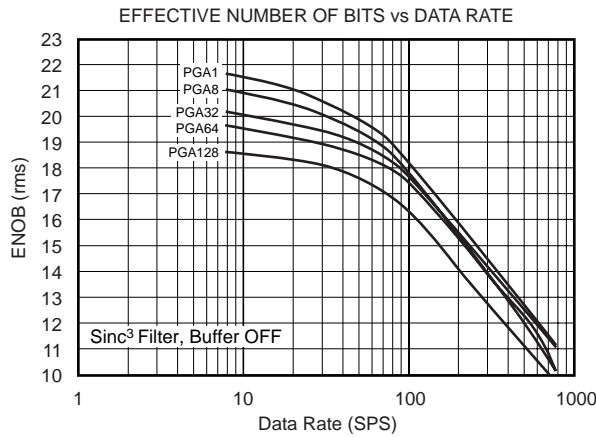

# TYPICAL CHARACTERISTICS (Cont.)

$AV_{DD} = +5V$ ,  $DV_{DD} = +5V$ ,  $f_{OSC} = 8MHz$ ,  $PGA = 1$ ,  $f_{MOD} = 15.625kHz$ , Bipolar, Buffer On, and  $V_{REF} \equiv (REF IN+) - (REF IN-) = +2.5V$ , unless otherwise specified. For  $V_{DAC}$ ,  $V_{REF} = AV_{DD}$ ,  $R_{LOAD} = 10k\Omega$ , and  $C_{LOAD} = 200pF$ , unless otherwise noted.

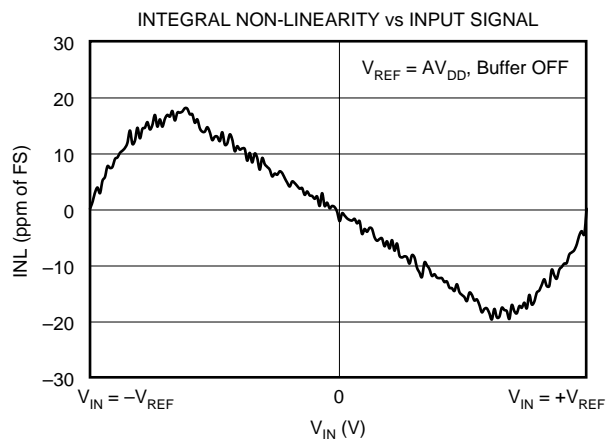
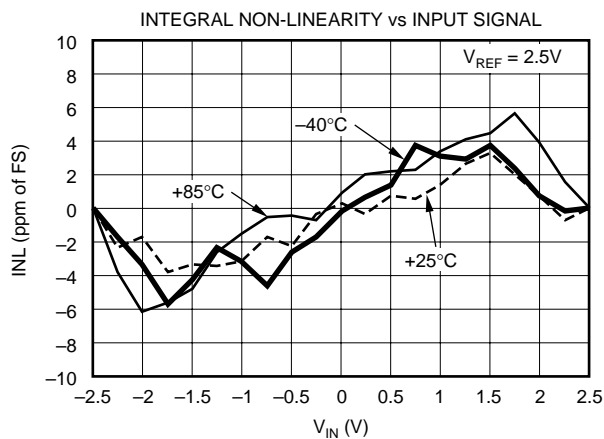
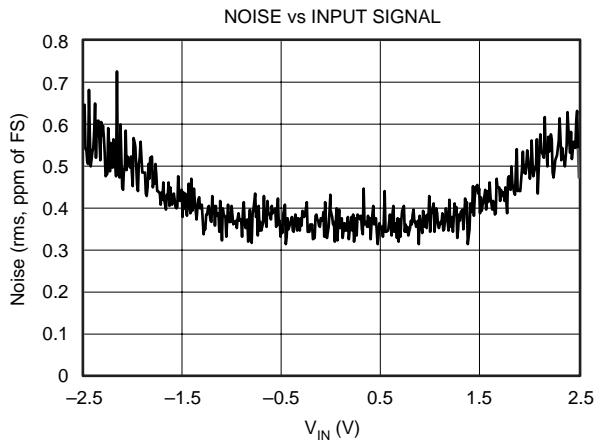
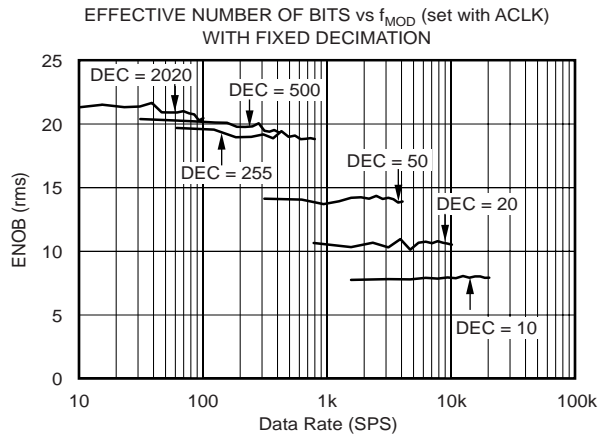
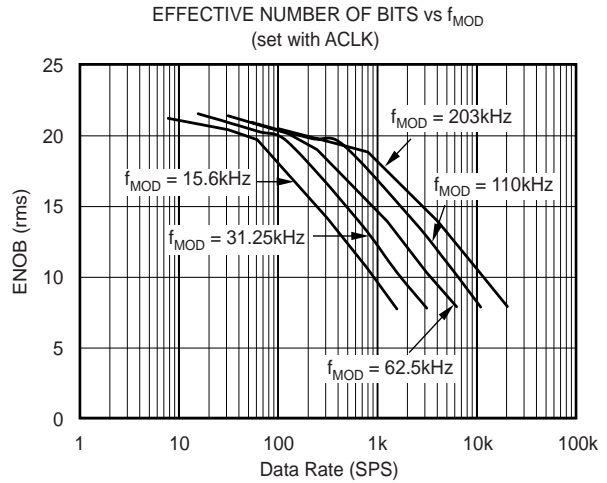
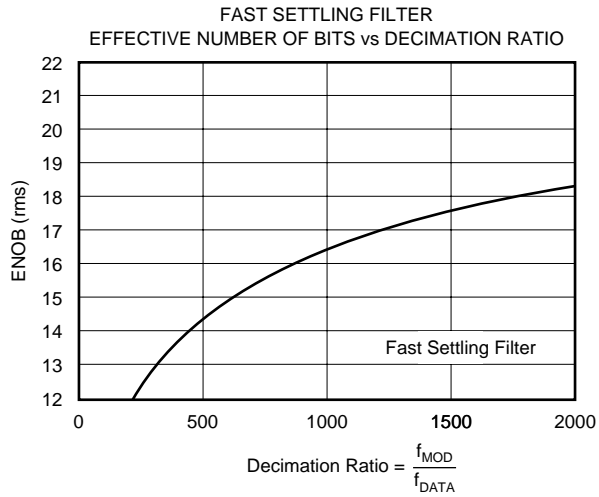

# TYPICAL CHARACTERISTICS (Cont.)

$AV_{DD} = +5V$ ,  $DV_{DD} = +5V$ ,  $f_{OSC} = 8MHz$ ,  $PGA = 1$ ,  $f_{MOD} = 15.625kHz$ , Bipolar, Buffer On, and  $V_{REF} \equiv (REF\ IN+) - (REF\ IN-) = +2.5V$ , unless otherwise specified. For  $V_{DAC}$ ,  $V_{REF} = AV_{DD}$ ,  $R_{LOAD} = 10k\Omega$ , and  $C_{LOAD} = 200pF$ , unless otherwise noted.

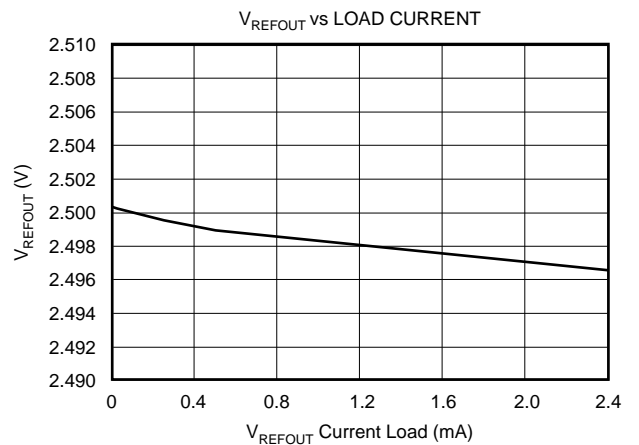
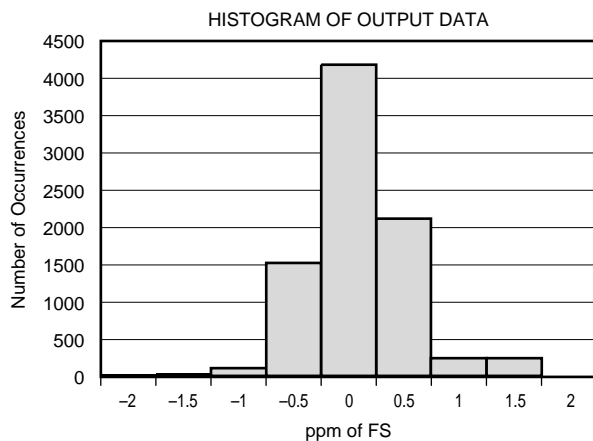
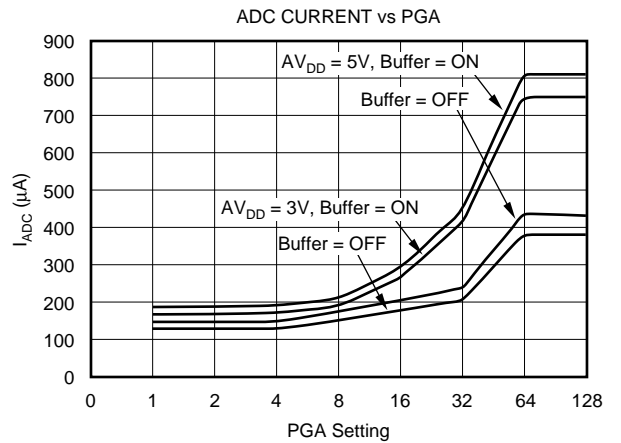
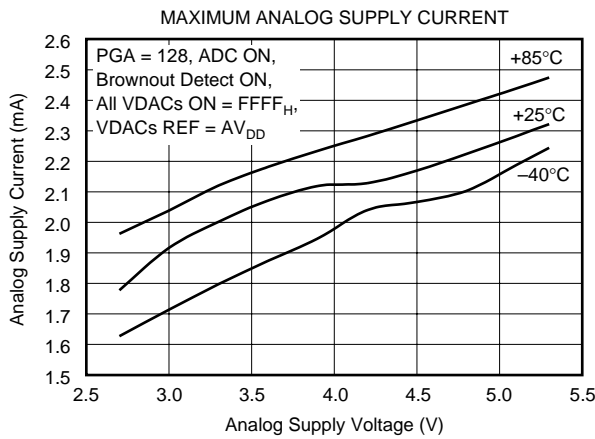
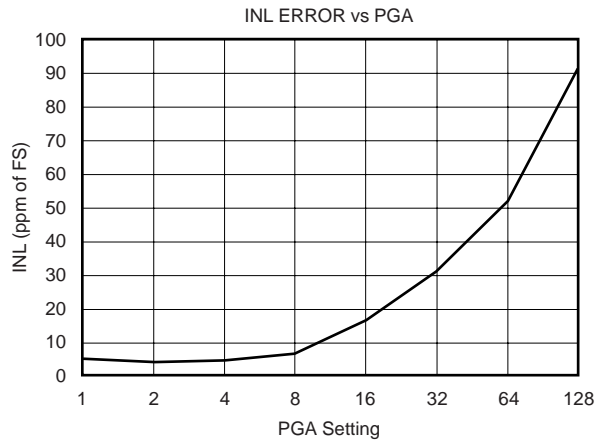
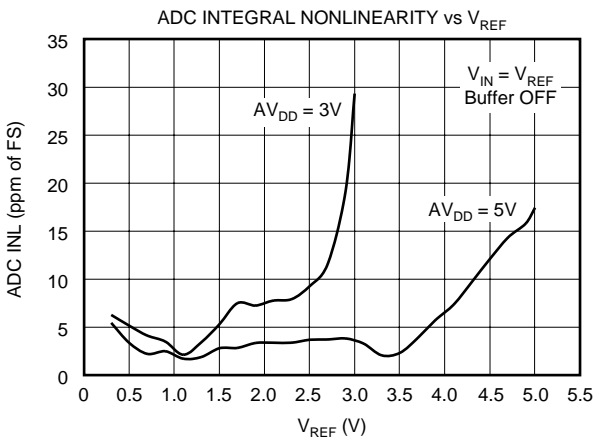

# TYPICAL CHARACTERISTICS (Cont.)

$V_{DD} = +5V$ ,  $DV_{DD} = +5V$ ,  $f_{OSC} = 8MHz$ ,  $PGA = 1$ ,  $f_{MOD} = 15.625kHz$ , Bipolar, Buffer On, and  $V_{REF} \equiv (REF\ IN+) - (REF\ IN-) = +2.5V$ , unless otherwise specified. For  $V_{DAC}$ ,  $V_{REF} = AV_{DD}$ ,  $R_{LOAD} = 10k\Omega$ , and  $C_{LOAD} = 200pF$ , unless otherwise noted.

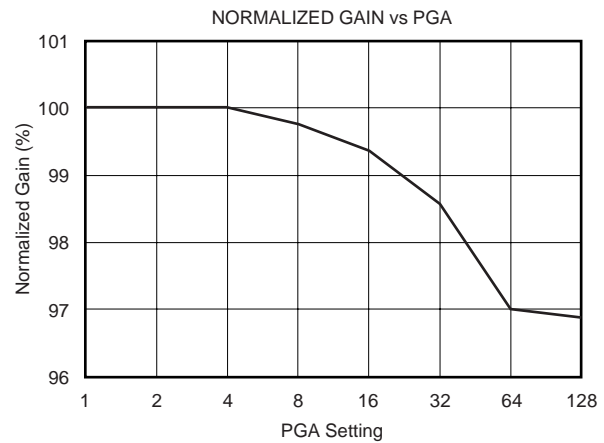
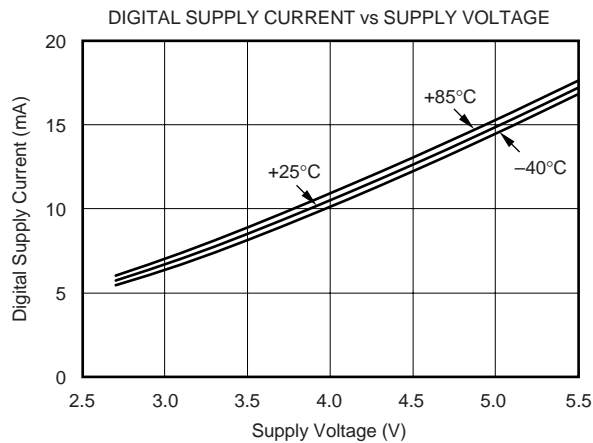
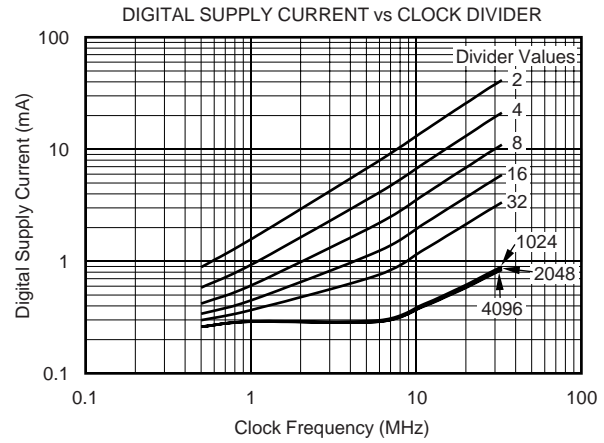
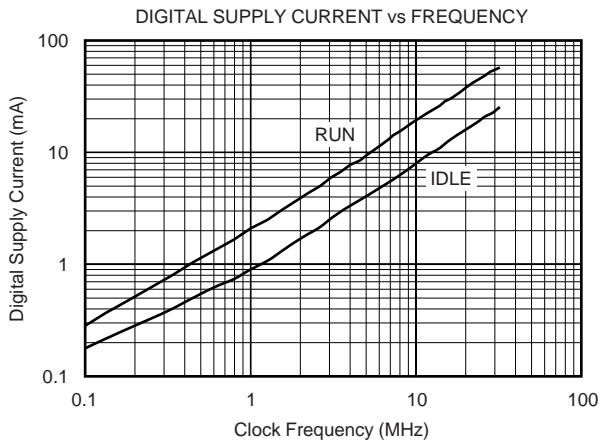
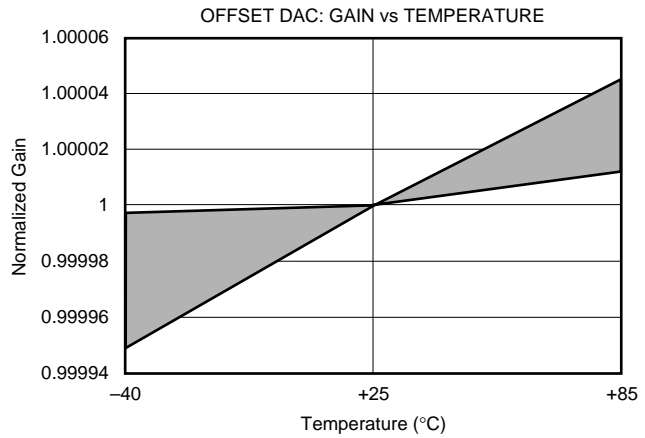
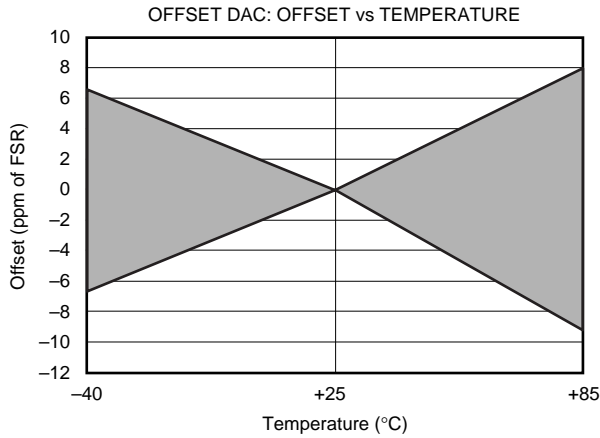

# TYPICAL CHARACTERISTICS (Cont.)

$AV_{DD} = +5V$ ,  $DV_{DD} = +5V$ ,  $f_{OSC} = 8MHz$ ,  $PGA = 1$ ,  $f_{MOD} = 15.625kHz$ , Bipolar, Buffer On, and  $V_{REF} \equiv (REF\ IN+) - (REF\ IN-) = +2.5V$ , unless otherwise specified. For  $V_{DAC}$ ,  $V_{REF} = AV_{DD}$ ,  $R_{LOAD} = 10k\Omega$ , and  $C_{LOAD} = 200pF$ , unless otherwise noted.

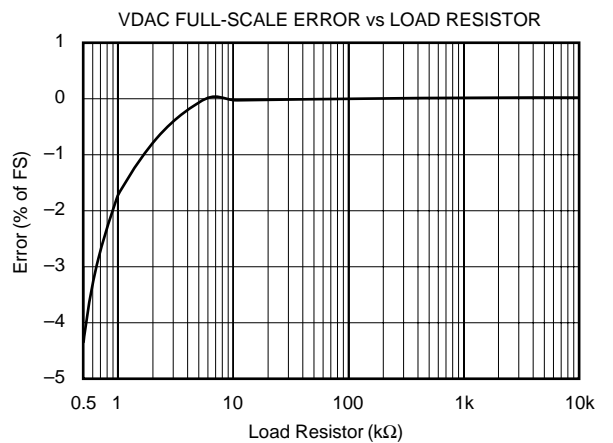
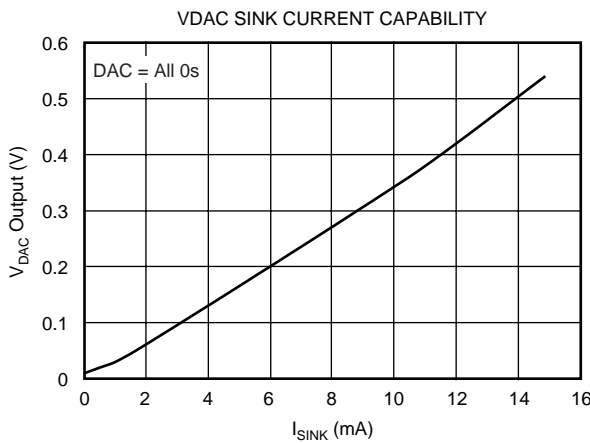
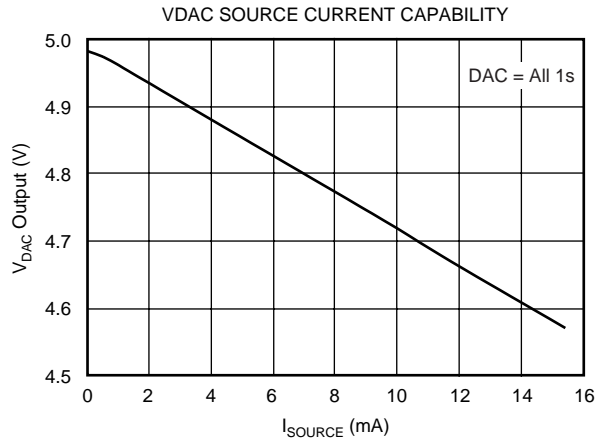
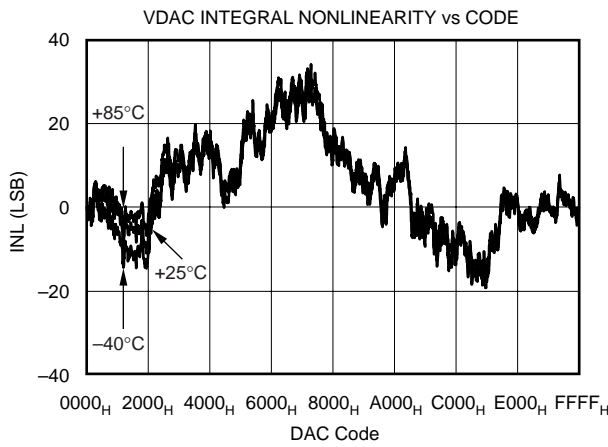
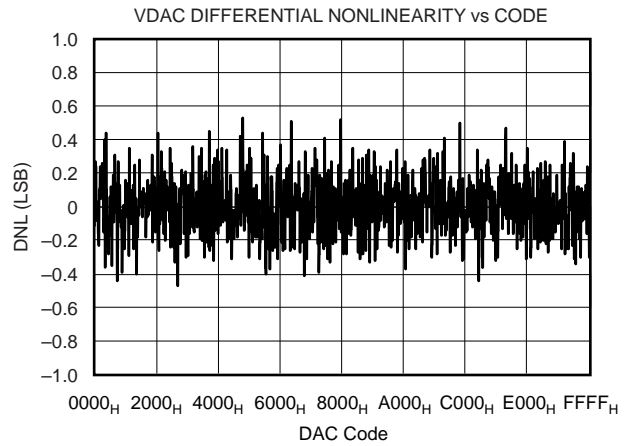
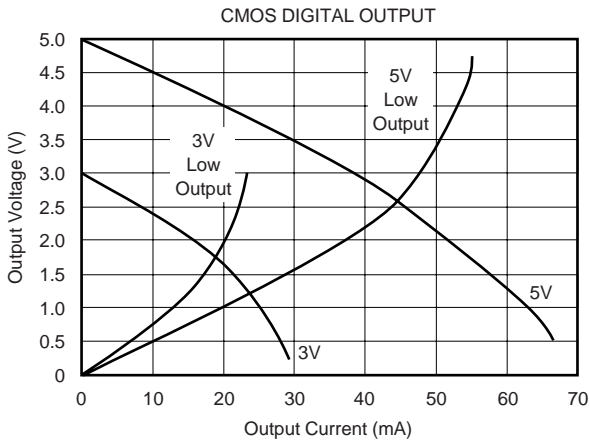

# TYPICAL CHARACTERISTICS (Cont.)

$AV_{DD} = +5V$ ,  $DV_{DD} = +5V$ ,  $f_{OSC} = 8MHz$ ,  $PGA = 1$ ,  $f_{MOD} = 15.625kHz$ , Bipolar, Buffer On, and  $V_{REF} \equiv (REF\ IN+) - (REF\ IN-) = +2.5V$ , unless otherwise specified. For  $V_{DAC}$ ,  $V_{REF} = AV_{DD}$ ,  $R_{LOAD} = 10k\Omega$ , and  $C_{LOAD} = 200pF$ , unless otherwise noted.

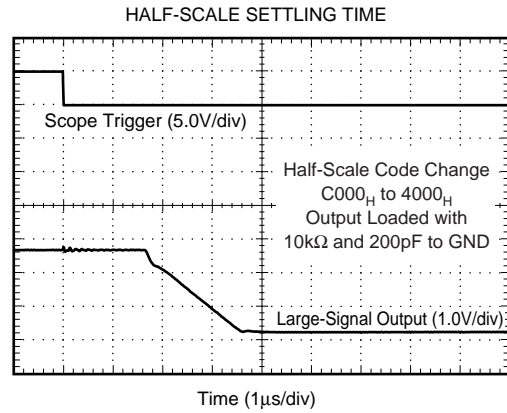
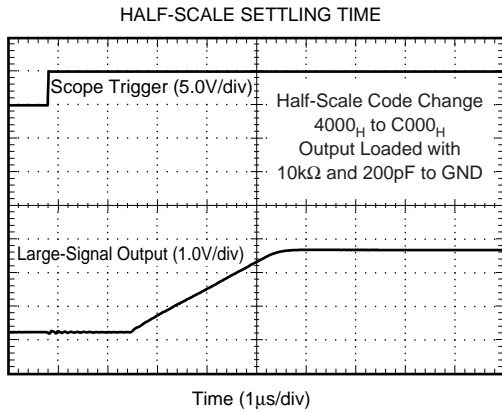
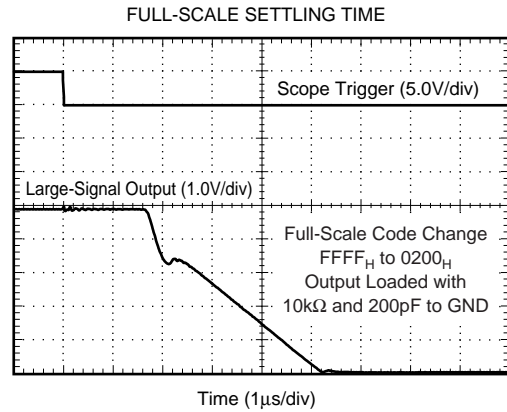
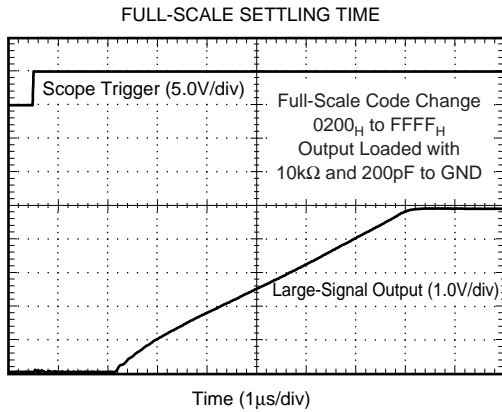

# DESCRIPTION

The MSC1212Yx is a completely integrated family of mixed-signal devices incorporating a high-resolution delta-sigma ADC, quad 16-bit DACs, 8-channel multiplexer, burnout detect current sources, selectable buffered input, offset DAC (Digital-to-Analog Converter), Programmable Gain Amplifier (PGA), temperature sensor, voltage reference, 8-bit microcontroller, Flash Program Memory, Flash Data Memory, and Data SRAM, as shown in Figure 1.

On-chip peripherals include an additional 32-bit accumulator, an SPI compatible serial port with FIFO, dual UARTs, multiple digital input/output ports, watchdog timer, low-voltage detect, on-chip power-on reset, 16-bit PWM, breakpoints, brownout reset, three timer/counters, and a system clock divider.

The device accepts low-level differential or single-ended signals directly from a transducer. The ADC provides 24 bits of resolution and 24 bits of no-missing-code performance using a sinc<sup>3</sup> filter with a programmable sample rate. The ADC also has a selectable filter that allows for high-resolution single-cycle conversion.

The microcontroller core is 8051 instruction set compatible. The microcontroller core is an optimized 8051 core which executes up to three times faster than the standard 8051 core, given the same clock source. That makes it possible to run the device at a lower external clock frequency and achieve the same performance at lower power than the standard 8051 core.

The MSC1212Yx allows the user to uniquely configure the Flash and SRAM memory maps to meet the needs of their application. The Flash is programmable down to 2.7V using both serial and parallel programming methods. The Flash endurance is 100k Erase/Write cycles. In addition, 1280 bytes of RAM are incorporated on-chip.

The part has separate analog and digital supplies, which can be independently powered from 2.7V to +5.5V. At +3V operation, the power dissipation for the part is typically less than 4mW. The MSC1212Yx is packaged in a TQFP-64 package.

The MSC1212Yx is designed for high-resolution measurement applications in smart transmitters, industrial process control, weigh scales, chromatography, and portable instrumentation.

## ENHANCED 8051 CORE

All instructions in the MSC1212 family perform exactly the same functions as they would in a standard 8051. The effect on bits, flags, and registers is the same. However, the timing is different. The MSC1212 family utilizes an efficient 8051 core which results in an improved instruction execution speed of between 1.5 and 3 times faster than the original core for the same external clock speed (4 clock cycles per instruction versus 12 clock cycles per instruction, as shown in Figure 2). This translates into an effective throughput improvement of more than 2.5 times, using the same code and same external clock speed. Therefore, a device frequency of 30MHz for the MSC1212Yx actually performs at an

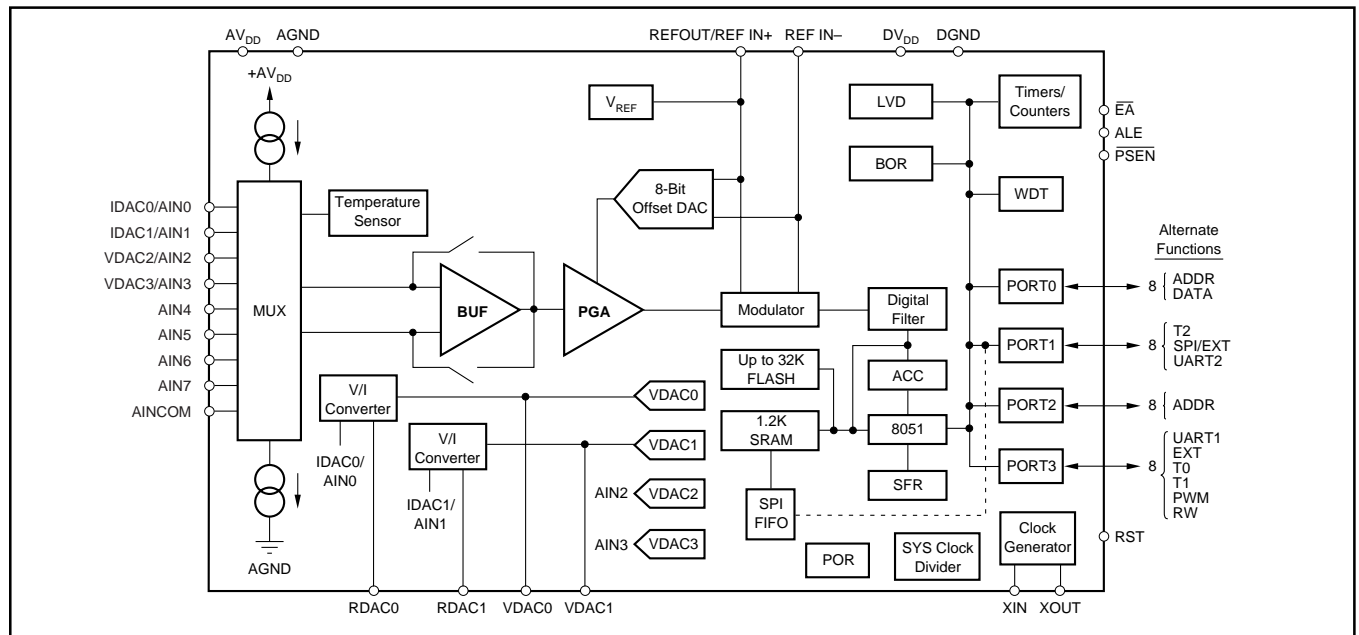

FIGURE 1. Block Diagram.

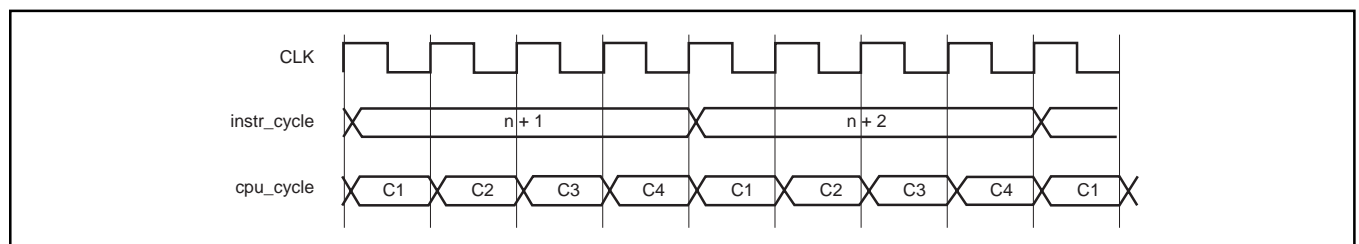

FIGURE 2. Instruction Cycle Timing.

equivalent execution speed of 75MHz compared to the standard 8051 core. This allows the user to run the device at slower external clock speeds which reduces system noise and power consumption, but provides greater throughput. This performance difference can be seen in Figure 3. The timing of software loops will be faster with the MSC1212. However, the timer/counter operation of the MSC1212 may be maintained at 12 clocks per increment or optionally run at 4 clocks per increment.

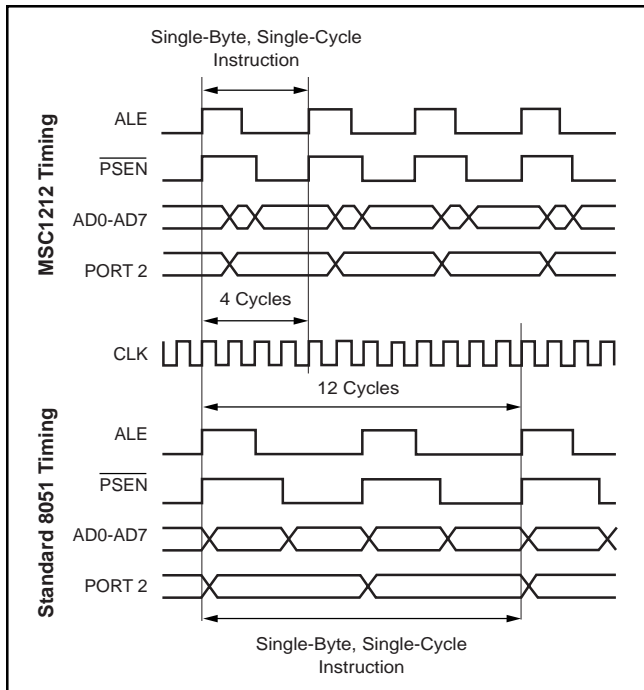

FIGURE 3. Comparison of MSC1212 Timing to Standard 8051 Timing.

The MSC1212 also provides dual data pointers (DPTRs) to speed block Data Memory moves.

Additionally, it can stretch the number of memory cycles to access external Data Memory from between two and nine instruction cycles in order to accommodate different speeds of memory or devices, as shown in Table I. The MSC1212 provides an external memory interface with a 16-bit address bus (P0 and P2). The 16-bit address bus makes it necessary to multiplex the low address byte through the P0 port. To enhance P0 and P2 for high-speed memory access, hardware configuration control is provided to configure the ports for external memory/peripheral interface or general-purpose I/O.

| CKCON (8E <sub>H</sub> ) MD2:MD0 | INSTRUCTION CYCLES (for MOVX) | RD or WR STROBE WIDTH (SYS CLKs) | RD or WR STROBE WIDTH (μs) AT 12MHz |
|----------------------------------|-------------------------------|----------------------------------|-------------------------------------|
| 000                              | 2                             | 2                                | 0.167                               |
| 001                              | 3 (default)                   | 4                                | 0.333                               |
| 010                              | 4                             | 8                                | 0.667                               |
| 011                              | 5                             | 12                               | 1.000                               |
| 100                              | 6                             | 16                               | 1.333                               |
| 101                              | 7                             | 20                               | 1.667                               |
| 110                              | 8                             | 24                               | 2.000                               |
| 111                              | 9                             | 28                               | 2.333                               |

TABLE I. Memory Cycle Stretching. Stretching of MOVX timing as defined by MD2, MD1, and MD0 bits in CKCON register (address 8E<sub>H</sub>).

Furthermore, improvements were made to peripheral features that off-load processing from the core, and the user, to further improve efficiency. For instance, the SPI interface uses a FIFO, which allows the SPI interface to transmit and receive data with minimum overhead needed from the core. Also, a 32-bit accumulator was added to significantly reduce the processing overhead for the multiple byte data from the ADC or other sources. This allows for 24-bit addition and shifting to be accomplished in a few instruction cycles, compared to hundreds of instruction cycles through software implementation.

### Family Device Compatibility

The hardware functionality and pin configuration across the MSC1212 family is fully compatible. To the user the only difference between family members is the memory configuration. This makes migration between family members simple. Code written for the MSC1212Y2 can be executed directly on an MSC1212Y3, MSC1212Y4, or MSC1212Y5. This gives the user the ability to add or subtract software functions and to freely migrate between family members. Thus, the MSC1212 can become a standard device used across several application platforms.

### Family Development Tools

The MSC1212 is fully compatible with the standard 8051 instruction set. This means that the user can develop software for the MSC1212 with their existing 8051 development tools. Additionally, a complete, integrated development environment is provided with each demo board, and third-party developers also provide support.

### Power Down Modes

The MSC1212 can power several of the peripherals and put the CPU into IDLE. This is accomplished by shutting off the clocks to those sections, as shown in Figure 4.

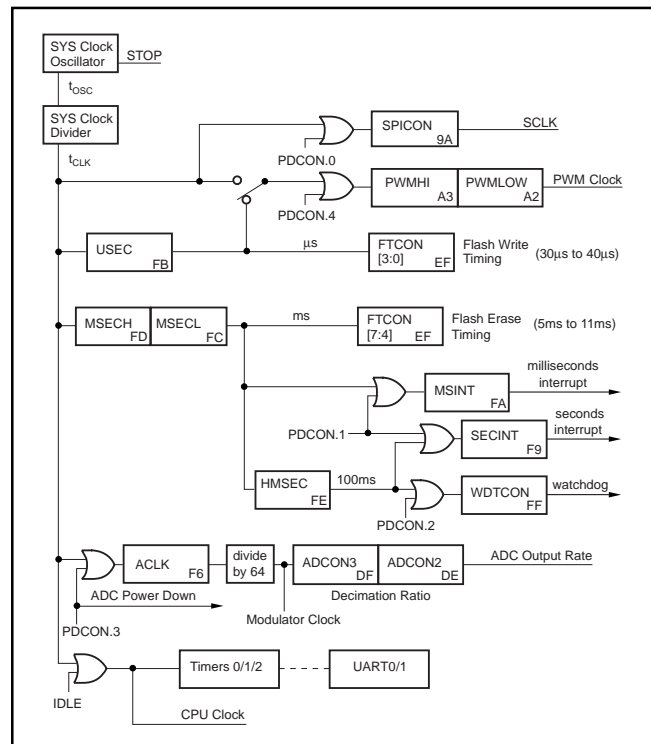

FIGURE 4. MSC1212 Timing Chain and Clock Control.

# OVERVIEW

## INPUT MULTIPLEXER

The input multiplexer provides for any combination of differential inputs to be selected as the input channel, as shown in Figure 5. If A<sub>IN0</sub> is selected as the positive differential input channel, any other channel can be selected as the negative differential input channel. With this method, it is possible to have up to eight fully differential input channels. It is also possible to switch the polarity of the differential input pair to negate any offset voltages.

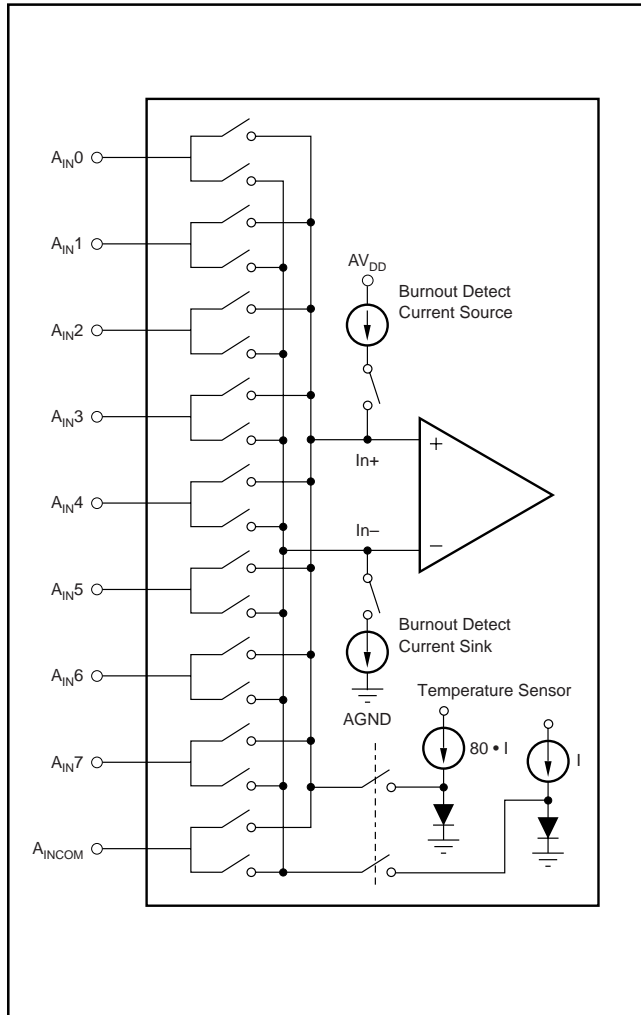

FIGURE 5. Input Multiplexer Configuration.

In addition, current sources are supplied that will source or sink current to detect open or short circuits on the pins.

## TEMPERATURE SENSOR

On-chip diodes provide temperature sensing capability. When the configuration register for the input MUX is set to all 1s, the diodes are connected to the input of the ADC. All other channels are open.

## BURNOUT DETECT

When the Burnout Detect (BOD) bit is set in the ADC control configuration register (ADCON0 DC<sub>H</sub>), two current sources are enabled. The current source on the positive input channel sources approximately 2μA of current. The current source on the negative input channel sinks approximately 2μA. This allows for the detection of an open circuit (full-scale reading) or short circuit (small differential reading) on the selected input differential pair.

## INPUT BUFFER

The analog input impedance is always high, regardless of PGA setting (when the buffer is enabled). With the buffer enabled, the input voltage range is reduced and the analog power-supply current is higher. If the limitation of input voltage range is acceptable, then the buffer is always preferred.

The input impedance of the MSC1212 without the buffer is 5MΩ/PGA. The buffer is controlled by the state of the BUF bit in the ADC control register (ADCON0 DC<sub>H</sub>).

## ANALOG INPUT

When the buffer is not selected, the input impedance of the analog input changes with ACLK clock frequency (ACLK F<sub>6H</sub>) and gain (PGA). The relationship is:

$$A_{IN} \text{ Impedance } (\Omega) = \left( \frac{1\text{MHz}}{\text{ACLK Frequency}} \right) \cdot \left( \frac{5\text{M}\Omega}{\text{PGA}} \right)$$

where ACLK frequency =  $f_{CLK}/(\text{ACLK} + 1)$ .

Figure 6 shows the basic input structure of the MSC1212. The sampling frequency varies according to the PGA settings, as shown in Table II.

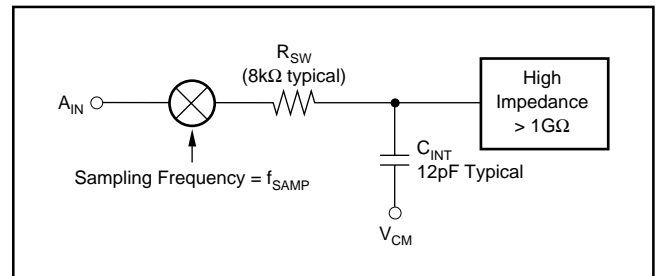

FIGURE 6. Analog Input Structure.

| PGA | FULL-SCALE RANGE       | SAMPLING FREQUENCY     |
|-----|------------------------|------------------------|
| 1   | ±V <sub>REF</sub>      | f <sub>SAMP</sub>      |
| 2   | ±V <sub>REF</sub> /2   | f <sub>SAMP</sub>      |
| 4   | ±V <sub>REF</sub> /4   | f <sub>SAMP</sub>      |
| 8   | ±V <sub>REF</sub> /8   | f <sub>SAMP</sub> • 2  |
| 16  | ±V <sub>REF</sub> /16  | f <sub>SAMP</sub> • 4  |
| 32  | ±V <sub>REF</sub> /32  | f <sub>SAMP</sub> • 8  |
| 64  | ±V <sub>REF</sub> /64  | f <sub>SAMP</sub> • 16 |
| 128 | ±V <sub>REF</sub> /128 | f <sub>SAMP</sub> • 16 |

NOTE: f<sub>SAMP</sub> = ACLK frequency/64.

TABLE II. Sampling Frequency Versus PGA Setting.

## PGA

The PGA can be set to gains of 1, 2, 4, 8, 16, 32, 64, or 128. Using the PGA can actually improve the effective resolution of the ADC. For instance, with a PGA of 1 on a  $\pm 2.5\text{V}$  full-scale range, the ADC can resolve to  $1.5\mu\text{V}$ . With a PGA of 128 on a  $\pm 19\text{mV}$  full-scale range, the ADC can resolve to  $75\text{nV}$ . With a PGA of 1 on a  $\pm 2.5\text{V}$  full-scale range, it would require a 26-bit ADC to resolve  $75\text{nV}$ , as shown in Table III.

| PGA SETTING | FULL-SCALE RANGE (V) | ENOB AT 10Hz | RMS MEASUREMENT RESOLUTION (nV) | EQUIVALENT ENOB AT PGA = 1 (5V RANGE) |
|-------------|----------------------|--------------|---------------------------------|---------------------------------------|
| 1           | $\pm 2.5\text{V}$    | 21.7         | 1468                            | 21.7                                  |
| 2           | $\pm 1.25$           | 21.5         | 843                             | 22.5                                  |
| 4           | $\pm 0.625$          | 21.4         | 452                             | 23.4                                  |
| 8           | $\pm 0.313$          | 21.2         | 259                             | 24.2                                  |
| 16          | $\pm 0.156$          | 20.8         | 171                             | 24.8                                  |
| 32          | $\pm 0.0781$         | 20.4         | 113                             | 25.4                                  |
| 64          | $\pm 0.039$          | 20           | 74.5                            | 26                                    |
| 128         | $\pm 0.019$          | 19           | 74.5                            | 26                                    |

TABLE III. ENOB Versus PGA.

## OFFSET DAC

The analog input to the PGA can be offset by up to half the full-scale input range of the PGA by using the ODAC register (SFR E6<sub>H</sub>). The ODAC (Offset DAC) register is an 8-bit value; the MSB is the sign and the seven LSBs provide the magnitude of the offset. Since the ODAC introduces an analog (instead of digital) offset to the PGA, using the ODAC does not reduce the performance of the ADC.

## MODULATOR

The modulator is a single-loop 2nd-order system. The modulator runs at a clock speed ( $f_{\text{MOD}}$ ) that is derived from the CLK using the value in the Analog Clock register (ACLK). The data output rate is:

$$\text{Data Rate} = f_{\text{MOD}} / \text{Decimation Ratio}$$

$$\text{where } f_{\text{MOD}} = f_{\text{CLK}} / (\text{ACLK} + 1) / 64$$

## CALIBRATION

The offset and gain errors in the MSC1212, or the complete system, can be reduced with calibration. Calibration is controlled through the ADCON1 register (SFR DD<sub>H</sub>), bits CAL2:CAL0. Each calibration process takes seven  $t_{\text{DATA}}$  periods (data conversion time) to complete. Therefore, it takes 14  $t_{\text{DATA}}$  periods to complete both an offset and gain calibration.

For system calibration, the appropriate signal must be applied to the inputs. The system offset command requires a “zero” differential input signal. It then computes an offset that will nullify offset in the system. The system gain command

requires a positive “full-scale” differential input signal. It then computes a value to nullify gain errors in the system. Each of these calibrations will take seven  $t_{\text{DATA}}$  periods to complete.

Calibration should be performed after power on, a change in temperature, decimation ratio, buffer, or a change of the PGA. Calibration will remove the effects of the Offset DAC, therefore, changes to the Offset DAC register must be done after calibration.

At the completion of calibration, the ADC Interrupt bit goes HIGH which indicates the calibration is finished and valid data is available.

## DIGITAL FILTER

The Digital Filter can use either the Fast Settling, sinc<sup>2</sup>, or sinc<sup>3</sup> filter, as shown in Figure 7. In addition, the Auto mode changes the sinc filter after the input channel or PGA is changed. When switching to a new channel, it will use the Fast Settling filter, for the next two conversions the first of which should be discarded. It will then use the sinc<sup>2</sup> followed by the sinc<sup>3</sup> filter to improve noise performance. This combines the low-noise advantage of the sinc<sup>3</sup> filter with the quick response of the Fast Settling Time filter. The frequency response of each filter is shown in Figure 8.

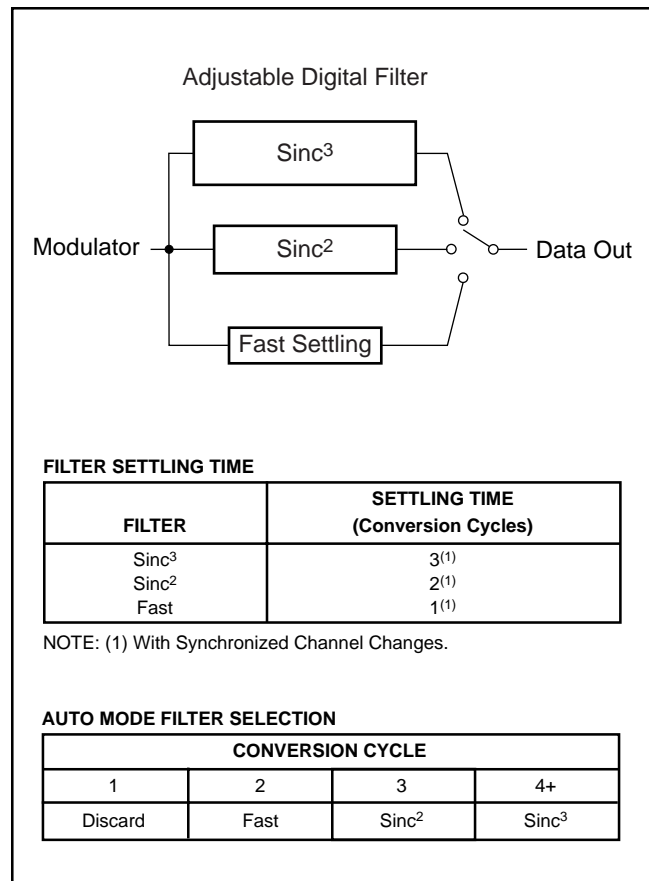

FIGURE 7. Filter Step Responses.

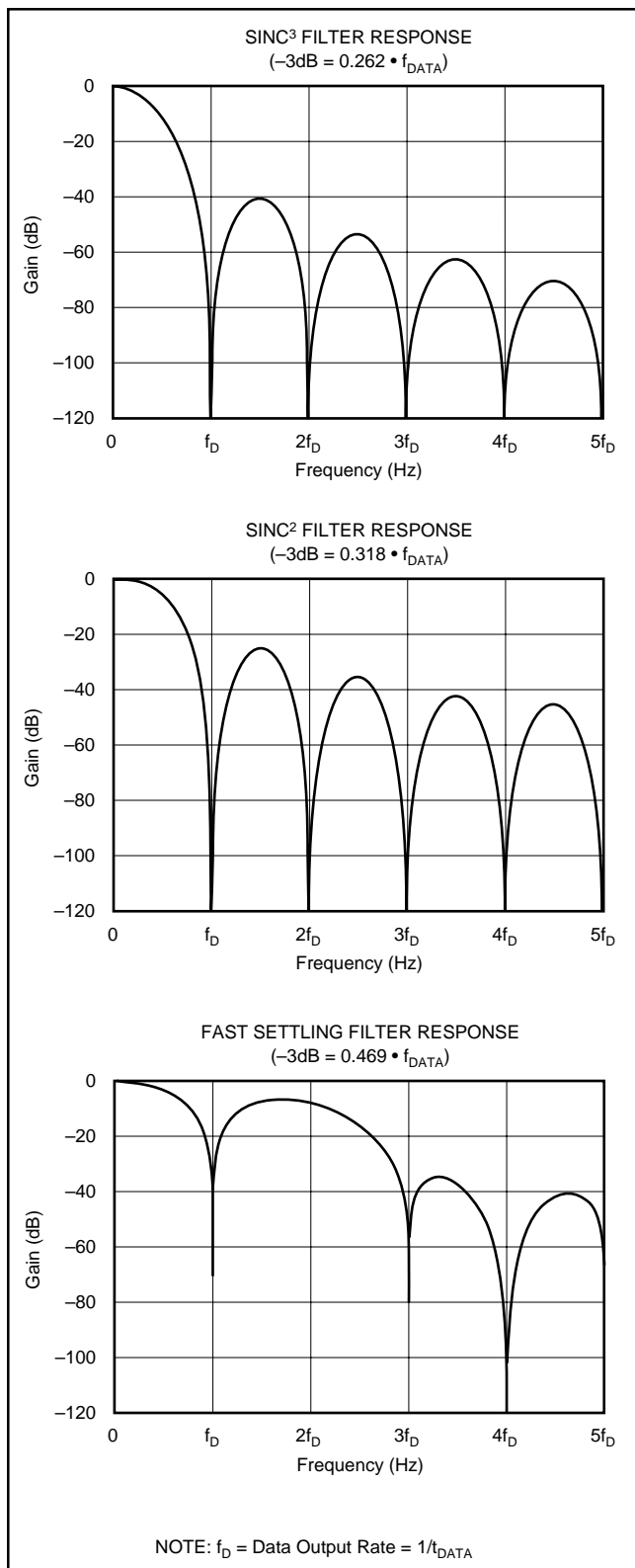

FIGURE 8. Filter Frequency Responses.

## VOLTAGE REFERENCE

The voltage reference used for the MSC1212 can either be internal or external. The power-up configuration for the voltage reference is 2.5V internal. The selection for the voltage reference is made through the ADCON0 register (SFR DC<sub>H</sub>). The internal voltage reference is selectable as either 1.25V (AV<sub>DD</sub> = 2.7V to 5.25V) or 2.5V (AV<sub>DD</sub> = 4.5V to 5.25V). If the internal V<sub>REF</sub> is not used, it should be turned off to reduce noise and power consumption. The V<sub>REFOUT</sub> pin should have a 0.1μF capacitor to AGND.

The external voltage reference is differential and is represented by the voltage difference between the pins: REF IN+ and REF IN-. The absolute voltage on either pin (REF IN+ and REF IN-) can range from AGND to AV<sub>DD</sub>, however, the differential voltage must not exceed 2.6V. The differential voltage reference provides easy means of performing ratiometric measurement.

## DAC

The architecture consists of a string DAC followed by an output buffer amplifier. Figure 9 shows a block diagram of the DAC architecture.

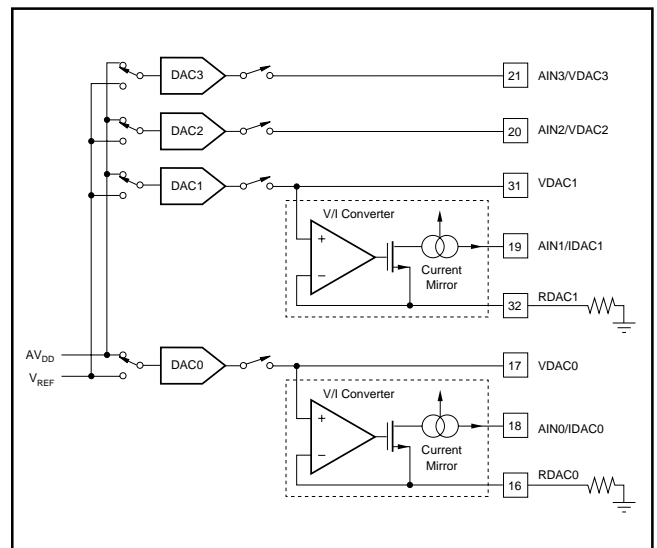

FIGURE 9. DAC Architecture.

The input coding to the DAC is straight binary, so the ideal output voltage is given by:

$$VDAC = V_{REF} \cdot \frac{D}{65536}$$

where D = decimal equivalent of the binary code that is loaded to the DAC register; it can range from 0 to 65535.

## RESISTOR STRING

The DAC selects the voltage from a string of resistors from the reference to AGND. It is essentially a string of resistors, each of value R. The code loaded into the DAC register determines at which node on the string the voltage is tapped off to be fed into the output amplifier by closing one of the switches connecting the string to the amplifier. It is ensured monotonic because it is a string of resistors.

## OUTPUT AMPLIFIER

The output buffer amplifier is capable of generating rail-to-rail voltages on its output which gives an output range of AGND to  $AV_{DD}$ . It is capable of driving a load of  $2k\Omega$  in parallel with  $1000pF$  to GND. The source and sink capabilities of the output amplifier can be seen in the typical curves. The slew rate is  $1V/\mu s$  with a full-scale settling time of  $8\mu s$  with the output unloaded.

## DAC REFERENCE

Each DAC can be selected to use the internal REFOUT/REF IN+ voltage or the supply voltage  $AV_{DD}$  as the reference for the DAC. The full range of the voltage DAC is limited according to Table IV. The full range of the current DAC is limited according to Table V.

| DAC REFERENCE      | $AV_{DD} = 5V$ | $AV_{DD} = 3V$  | $AV_{DD} < 3.0V$ |
|--------------------|----------------|-----------------|------------------|
| DACREF = $AV_{DD}$ | Full Range     | Full Range      | Not Recommended  |
| DACREF = 2.5V      | Full Range     | Not Recommended | Not Recommended  |
| DACREF = 1.25V     | Full Range     | Full Range      | Not Recommended  |

TABLE IV. Voltage DAC Code Range.

| DAC REFERENCE      | $AV_{DD} = 5V$         | $AV_{DD} = 3V$         | $AV_{DD} < 3.0V$ |
|--------------------|------------------------|------------------------|------------------|
| DACREF = $AV_{DD}$ | 0000-7FFF <sub>H</sub> | 0000-3FFF <sub>H</sub> | Not Recommended  |
| DACREF = 2.5V      | Full Range             | Not Recommended        | Not Recommended  |
| DACREF = 1.25V     | Full Range             | Full Range             | Not Recommended  |

TABLE V. Current DAC Code Range.

## DAC LOADING

The DAC can be selected to be turned off with a  $1k\Omega$ ,  $100k\Omega$ , or open circuit on the DAC outputs.

## BIPOLAR OPERATION USING THE DAC

The DAC can be used for a bipolar output range, as shown in Figure 10. The circuit shown will give an output voltage range of  $\pm V_{REF}$ . Rail-to-rail operation at the amplifier output is achievable using an OPA703 as the output amplifier.

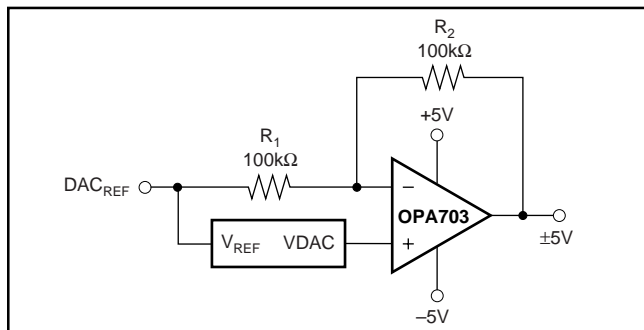

FIGURE 10. Bipolar Operation with the DAC.

The output voltage for any input code can be calculated as follows:

$$V_O = \left[ DAC_{REF} \cdot \left( \frac{D}{65536} \right) \cdot \left( \frac{R_1 + R_2}{R_1} \right) - DAC_{REF} \cdot \left( \frac{R_2}{R_1} \right) \right]$$

where D represents the input code in decimal (0–65535).

With  $DAC_{REF} = 5V$ ,  $R_1 = R_2 = 10k\Omega$ :

$$V_O = \left( \frac{10 \cdot D}{65536} \right) - 5V$$

This is an output voltage range of  $\pm 5V$  with 0000<sub>H</sub> corresponding to a  $-5V$  output and FFFF<sub>H</sub> corresponding to a  $+5V$  output. Similarly, using  $V_{REF} = 2.5V$ , a  $\pm 2.5V$  output voltage can be achieved.

## IDAC

The compliance specification of the IDAC output defines the maximum output voltage to achieve the expected current. Refer to Figure 9 for the IDAC structure and to Table V for the DAC reference selection and code range.

## POWER-UP—SUPPLY VOLTAGE RAMP RATE

The built-in (on-chip) power-on reset circuitry was designed to accommodate analog or digital supply ramp rates as slow as  $1V/10ms$ . To ensure proper operation, the power supply should ramp monotonically at the specified rate. If BOR is enabled, the ramp rate can be slower.

## MEMORY MAP

The MSC1212 contains on-chip SFR, Flash Memory, Scratchpad RAM Memory, Boot ROM, and SRAM. The SFR registers are primarily used for control and status. The standard 8051 features and additional peripheral features of the MSC1212 are controlled through the SFR. Reading from undefined SFR will return zero and writing to undefined SFR registers is not recommended and will have indeterminate effects.

Flash Memory is used for both Program Memory and Data Memory. The user has the ability to select the partition size of Program and Data Memories. The partition size is set through hardware configuration bits, which are programmed through either the parallel or serial programming methods. Both Program and Data Flash Memories are erasable and writable (programmable) in user application mode. However, only program execution can occur from Program Memory. As an added precaution, a lock feature can be activated through the hardware configuration bits, which disables erase and writes to 4kB of Program Flash Memory or the entire Program Flash Memory in user application mode.

The MSC1212 includes 1kB of SRAM on-chip. SRAM starts at address 0 and is accessed through the MOVX instruction. This SRAM can also be located to start at 8400<sub>H</sub> and can be accessed as both Program and Data Memory.

## FLASH MEMORY

The MSC1212 uses a memory addressing scheme that separates Program Memory (FLASH/ROM) from Data Memory (FLASH/RAM). Each area is 64kB beginning at address 0000<sub>H</sub> and ending at FFFF<sub>H</sub>, as shown in Figure 11. The program and data segments can overlap since they are accessed in different ways. Program Memory is fetched by the microcontroller automatically. There is one instruction (MOVC) that is used to explicitly read the program area. This is commonly used to read lookup tables. The Data Memory area is accessed explicitly using the MOVX instruction. This instruction provides multiple ways of specifying the target address. It is used to access the 64kB of Data Memory. The address and data range of devices with on-chip Program and Data Memory overlap the 64kB memory space. When on-chip memory is enabled, accessing memory in the on-chip range will cause the device to access internal memory. Memory accesses beyond the internal range will be addressed externally via Ports 0 and 2.

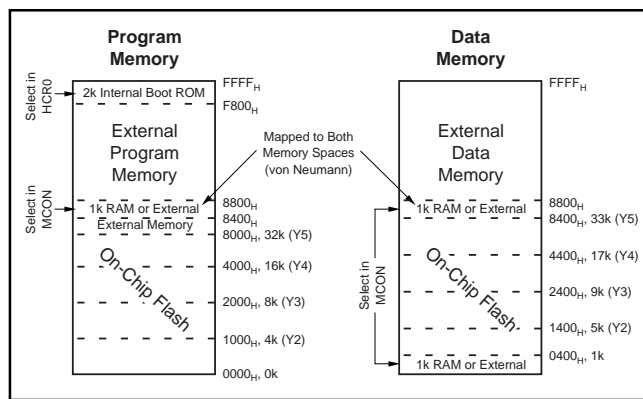

FIGURE 11. Memory Map.

The MSC1212 has two Hardware Configuration registers (HCR0 and HCR1) that are programmable only during Flash Memory Programming mode.

The MSC1212 allows the user to partition the Flash Memory between Program Memory and Data Memory. For instance, the MSC1212Y5 contains 32kB of Flash Memory on-chip. Through the HW configuration registers, the user can define the partition between Program Memory (PM) and Data Memory (DM), as shown in Tables VI and VII. The MSC1212 family offers four memory configurations.

| HCR0          | MSC1212Y2 |     | MSC1212Y3 |     | MSC1212Y4 |      | MSC1212Y5 |      |
|---------------|-----------|-----|-----------|-----|-----------|------|-----------|------|
| DFSEL         | PM        | DM  | PM        | DM  | PM        | DM   | PM        | DM   |
| 000           | 0kB       | 4kB | 0kB       | 8kB | 0kB       | 16kB | 0kB       | 32kB |
| 001           | 0kB       | 4kB | 0kB       | 8kB | 0kB       | 16kB | 0kB       | 32kB |
| 010           | 0kB       | 4kB | 0kB       | 8kB | 0kB       | 16kB | 16kB      | 16kB |
| 011           | 0kB       | 4kB | 0kB       | 8kB | 8kB       | 8kB  | 24kB      | 8kB  |
| 100           | 0kB       | 4kB | 4kB       | 4kB | 12kB      | 4kB  | 28kB      | 4kB  |
| 101           | 2kB       | 2kB | 6kB       | 2kB | 14kB      | 2kB  | 30kB      | 2kB  |
| 110           | 3kB       | 1kB | 7kB       | 1kB | 15kB      | 1kB  | 31kB      | 1kB  |
| 111 (default) | 4kB       | 0kB | 8kB       | 0kB | 16kB      | 0kB  | 32kB      | 0kB  |

NOTE: When a 0kB program memory configuration is selected program execution is external.

TABLE VI. MSC1212Y Flash Partitioning.

| HCR0          | MSC1212Y2 |           | MSC1212Y3 |           | MSC1212Y4 |           | MSC1212Y5 |           |
|---------------|-----------|-----------|-----------|-----------|-----------|-----------|-----------|-----------|
| DFSEL         | PM        | DM        | PM        | DM        | PM        | DM        | PM        | DM        |
| 000           | 0000      | 0400-13FF | 0000      | 0400-23FF | 0000      | 0400-43FF | 0000      | 0400-83FF |
| 001           | 0000      | 0400-13FF | 0000      | 0400-23FF | 0000      | 0400-43FF | 0000      | 0400-83FF |
| 010           | 0000      | 0400-13FF | 0000      | 0400-23FF | 0000      | 0400-43FF | 0000-3FFF | 0400-43FF |
| 011           | 0000      | 0400-13FF | 0000      | 0400-23FF | 0000-1FFF | 0400-23FF | 0000-5FFF | 0400-23FF |
| 100           | 0000      | 0400-13FF | 0000-0FFF | 0400-13FF | 0000-2FFF | 0400-13FF | 0000-6FFF | 0400-13FF |
| 101           | 0000-07FF | 0400-0BFF | 0000-17FF | 0400-0BFF | 0000-37FF | 0400-0BFF | 0000-77FF | 0400-0BFF |
| 110           | 0000-0BFF | 0400-07FF | 0000-1BFF | 0400-07FF | 0000-3BFF | 0400-07FF | 0000-7BFF | 0400-07FF |
| 111 (default) | 0000-0FFF | 0000      | 0000-1FFF | 0000      | 0000-3FFF | 0000      | 0000-7FFF | 0000      |

NOTE: Program memory accesses above the highest listed address will access external program memory.

TABLE VII. Flash Memory Partitioning.

It is important to note that the Flash Memory is readable and writable (depending on the MXWS bit in the MWS SFR) by the user through the MOVX instruction when configured as either Program or Data Memory. This means that the user may partition the device for maximum Flash Program Memory size (no Flash Data Memory) and use Flash Program Memory as Flash Data Memory. This may lead to undesirable behavior if the PC points to an area of Flash Program Memory that is being used for data storage. Therefore, it is recommended to use Flash partitioning when Flash Memory is used for data storage. Flash partitioning prohibits execution of code from Data Flash Memory. Additionally, the Program Memory erase/write can be disabled through hardware configuration bits (HCR0), while still providing access (read/write/erase) to Data Flash Memory.

The effect of memory mapping on Program and Data Memory is straightforward. The Program Memory is decreased in size from the top of internal Program Memory. Therefore, if the MSC1212Y5 is partitioned with 31kB of Flash Program Memory and 1kB of Flash Data Memory, external Program Memory execution will begin at 7C00<sub>H</sub> (versus 8000<sub>H</sub> for 32kB). The Flash Data Memory is added on top of the SRAM memory. Therefore, access to Data Memory (through MOVX) will access SRAM for addresses 0000<sub>H</sub>-03FF<sub>H</sub> and access Flash Memory for addresses 0400<sub>H</sub>-07FF<sub>H</sub>.

### Data Memory

The MSC1212 can address 64kB of Data Memory. Scratchpad Memory provides 256 bytes in addition to the 64kB of Data Memory. The MOVX instruction is used to access the Data SRAM Memory. This includes 1024 bytes of on-chip Data SRAM Memory. The data bus values do not appear on Port 0 (during data bus timing) for internal memory access.

The MSC1212 also has on-chip Flash Data Memory which is readable and writable (depending on Memory Write Select register) during normal operation (full V<sub>DD</sub> range). This memory is mapped into the external Data Memory space directly above the SRAM.

## REGISTER MAP

The Register Map is illustrated in Figure 12. It is entirely separate from the Program and Data Memory areas mentioned before. A separate class of instructions is used to access the registers. There are 256 potential register locations. In practice, the MSC1212 has 256 bytes of Scratchpad RAM and up to 128 SFRs. This is possible, since the upper 128 Scratchpad RAM locations can only be accessed indirectly. That is, the contents of a Working Register (described below) will designate the RAM location. Thus, a direct reference to one of the upper 128 locations must be an SFR access. Direct RAM is reached at locations 0 to 7F<sub>H</sub> (0 to 127).

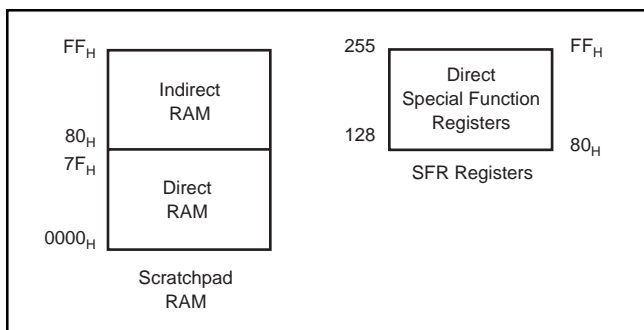

FIGURE 12. Register Map.

SFRs are accessed directly between 80<sub>H</sub> and FF<sub>H</sub> (128 to 255). The RAM locations between 128 and 255 can be reached through an indirect reference to those locations. Scratchpad RAM is available for general-purpose data storage. It is commonly used in place of off-chip RAM when the total data contents are small. When off-chip RAM is needed, the Scratchpad area will still provide the fastest general-purpose access. Within the 256 bytes of RAM, there are several special-purpose areas.

### Bit Addressable Locations

In addition to direct register access, some individual bits are also accessible. These are individually addressable bits in both the RAM and SFR area. In the Scratchpad RAM area, registers 20<sub>H</sub> to 2F<sub>H</sub> are bit addressable. This provides 128 (16 • 8) individual bits available to software. A bit access is distinguished from a full-register access by the type of instruction. In the SFR area, any register location ending in a 0 or 8 is bit addressable. Figure 13 shows details of the on-chip RAM addressing including the locations of individual RAM bits.

### Working Registers

As part of the lower 128 bytes of RAM, there are four banks of Working Registers, as shown in Figure 13. The Working Registers are general-purpose RAM locations that can be addressed in a special way. They are designated R0 through R7. Since there are four banks, the currently selected bank will be used by any instruction using R0-R7. This allows software to change context by simply switching banks. This is controlled via the Program Status Word register (PSW; 0D0<sub>H</sub>) in the SFR area described below. Registers R0 and R1 also allow their contents to be used for indirect addressing of the upper 128 bytes of RAM. Thus, an instruction can designate the value

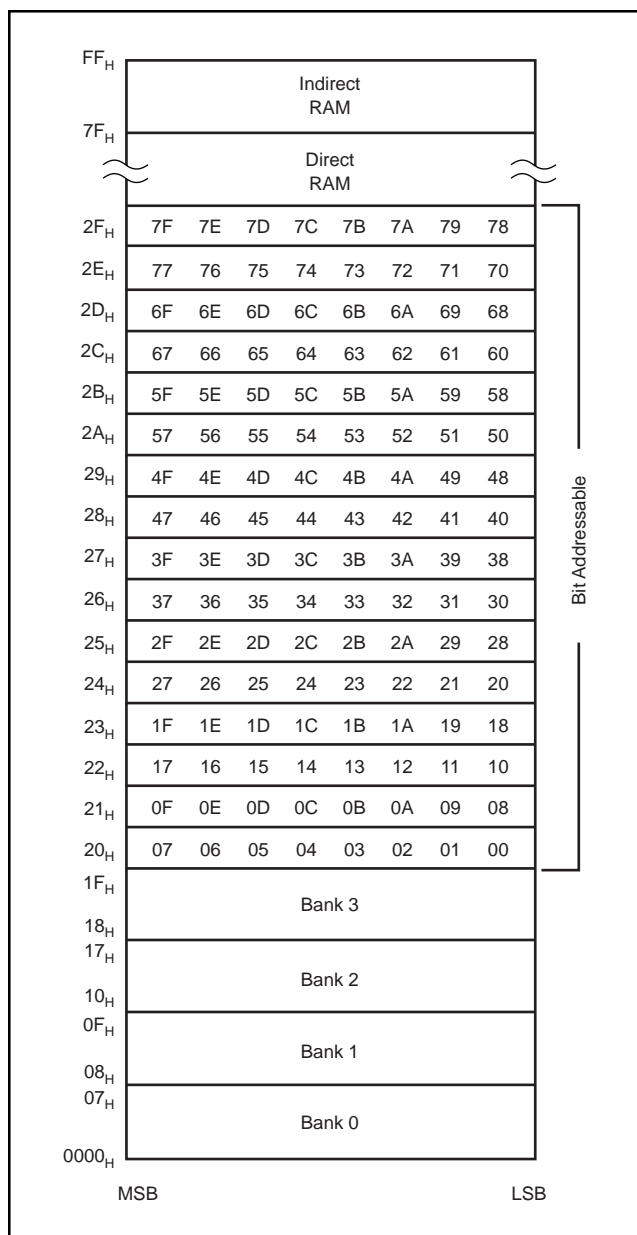

FIGURE 13. Scratchpad Register Addressing.

stored in R0 (for example) to address the upper RAM. The 16 bytes immediately above these registers are bit addressable. So any of the 128 bits in this area can be directly accessed using bit addressable instructions.

### Stack

Another use of the Scratchpad area is for the programmer's stack. This area is selected using the Stack Pointer (SP; 81<sub>H</sub>) SFR. Whenever a call or interrupt is invoked, the return address is placed on the Stack. It also is available to the programmer for variables, etc., since the Stack can be moved and there is no fixed location within the RAM designated as Stack. The Stack Pointer will default to 07<sub>H</sub> on reset. The user can then move it as needed. A convenient location would be the upper RAM area (> 7F<sub>H</sub>) since this is only available indirectly. The SP will point to the last used value. Therefore, the next value placed on the Stack is put at SP + 1. Each PUSH or CALL will increment the SP by the appropriate value. Each POP or RET will decrement as well.

## Program Memory

After reset, the CPU begins execution from Program Memory location 0000<sub>H</sub>. The selection of where Program Memory execution begins is made by tying the  $\overline{EA}$  pin to  $V_{DD}$  for internal access, or DGND for external access. When  $\overline{EA}$  is tied to  $V_{DD}$ , any PC fetches outside the internal Program Memory address occur from external memory. If  $\overline{EA}$  is tied to DGND, then all PC fetches address external memory. The standard internal Program Memory size for MSC1212 family members is shown in Table VIII. Refer to the Accessing External Memory section for details on using external Program Memory. If enabled the Boot ROM will appear from address F800<sub>H</sub> to FFFF<sub>H</sub>.

| MODEL NUMBER | STANDARD INTERNAL PROGRAM MEMORY SIZE (BYTES) |
|--------------|---|
| MSC1212Y5    | 32k   |
| MSC1212Y4    | 16k   |
| MSC1212Y3    | 8k  |
| MSC1212Y2    | 4k  |

TABLE VIII. MSC1212 Maximum Internal Program Memory Sizes.

## ACCESSING EXTERNAL MEMORY

If external memory is used, P0 and P2 can be configured as address and data lines. If external memory is not used, P0 and P2 can be configured as general-purpose I/O lines through the Hardware Configuration Register.

To enable access to external memory bits 0 and 1 of the HCR1 register must be set to 0. When these bits are enabled all memory accesses for both internal and external memory will appear on ports 0 and 2. During the data portion of the cycle for internal memory, Port 0 will be zero for security purposes.

Accesses to external memory are of two types: accesses to external Program Memory and accesses to external Data Memory. Accesses to external Program Memory use signal  $\overline{PSEN}$  (program store enable) as the read strobe. Accesses to external Data Memory use  $\overline{RD}$  or  $\overline{WR}$  (alternate functions of P3.7 and P3.6) to strobe the memory.

External Program Memory and external Data Memory may be combined if desired by applying the  $\overline{RD}$  and  $\overline{PSEN}$  signals to the inputs of an AND gate and using the output of the gate as the read strobe to the external Program/Data Memory.

A program fetch from external Program Memory uses a 16-bit address. Accesses to external Data Memory can use either a 16-bit address (MOVX @DPTR) or an 8-bit address (MOVX @R<sub>i</sub>).

If Port 2 is selected for external memory use (HCR1, bit 0), it can not be used as a general-purpose I/O. This bit (or Bit 1 of HCR1) also forces bits P3.6 and P3.7 to be used for  $\overline{WR}$  and  $\overline{RD}$  instead of I/O. Port 2, P3.6, and P3.7 should all be written to '1'.

If an 8-bit address is being used (MOVX @R<sub>i</sub>), the contents of the MPAGE (92<sub>H</sub>) SFR remain at the Port 2 pins throughout the external memory cycle. This will facilitate paging.

In any case, the low byte of the address is time-multiplexed with the data byte on Port 0. The ADDR/DATA signals use CMOS drivers in the Port 0, Port 2,  $\overline{WR}$ , and  $\overline{RD}$  output buffers. Thus, in this application the Port 0 pins are not open-drain outputs, and do not require external pull-ups for high-speed access. Signal ALE (Address Latch Enable) should be used to capture the address byte into an external latch. The address byte is valid at the negative transition of ALE. Then, in a write cycle, the data byte to be written appears on Port 0 just before  $\overline{WR}$  is activated, and remains there until after  $\overline{WR}$  is deactivated. In a read cycle, the incoming byte is accepted at Port 0 just before the read strobe is deactivated.

The function of Port 0 and Port 2 is selected in Hardware Configuration Register 1. This can only be changed during the Flash Program mode. There is no conflict in the use of these registers; they will either be used as general-purpose I/O or for external memory access. The default state is for Port 0 and Port 2 to be used as general-purpose I/O. If an external memory access is attempted when they are configured as general-purpose I/O, the values of Port 0 and Port 2 will not be affected.

External Program Memory is accessed under two conditions:

- 1) Whenever signal  $\overline{EA}$  is LOW during reset, then all future accesses are external, or
- 2) Whenever the Program Counter (PC) contains a number that is outside of the internal Program Memory address range, if the ports are enabled.

If Port 0 and Port 2 is selected for external memory, all 8 bits of Port 0 and Port 2, as well as P3.6 and P3.7, are dedicated to an output function and may not be used for general-purpose I/O. During external program fetches, Port 2 outputs the high byte of the PC.

## Programming Flash Memory

There are four sections of Flash Memory for programming.

1. 128 configuration bytes.
2. Reset sector (4kB) (not to be confused with the 2kB Boot ROM).
3. Program Memory.
4. Data Memory.

## Boot Rom

There is a 2kB Boot ROM that controls operation during serial or parallel programming. Additionally, the Boot ROM routines can be accessed during the user mode if it is enabled. When enabled, the Boot ROM routines will be located at memory addresses F800<sub>H</sub>-FFFF<sub>H</sub> during user mode. In program mode the Boot ROM is located in the first 2kB of Program Memory.

## Flash Programming Mode

There are two programming modes: parallel and serial. The programming mode is selected by the state of the ALE and  $\overline{\text{PSEN}}$  signals during power-on reset. Serial programming mode is selected with  $\overline{\text{PSEN}} = 0$  and ALE = 1. Parallel programming mode is selected with  $\overline{\text{PSEN}} = 1$  and ALE = 0 (see Figure 14). If they are both HIGH, the MSC1212 will

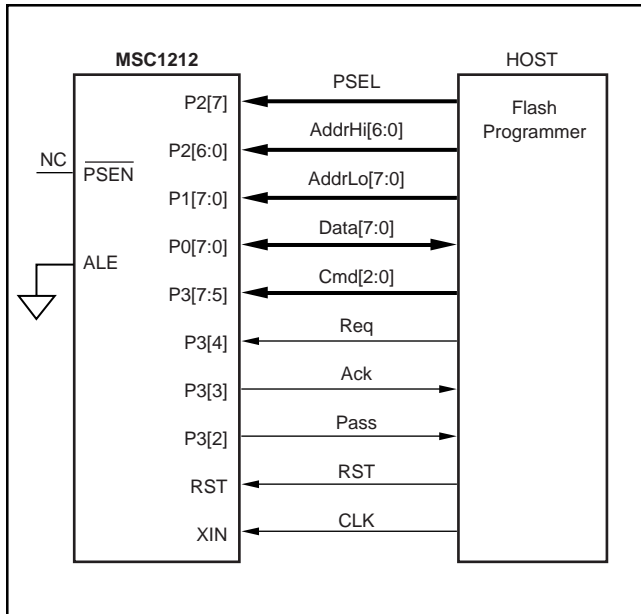

FIGURE 14. Parallel Programming Configuration.

operate in normal user mode. Both signals LOW is a reserved mode and is not defined. Programming mode is exited with a power-on reset signal and the normal mode selected.

The MSC1212 is shipped with Flash Memory erased (all 1s). Parallel programming methods typically involve a third-party programmer. Serial programming methods typically involve in-system programming. User Application mode allows Flash Program and Data Memory programming. The actual code for Flash programming can not execute from Flash. That code must execute from the Boot ROM or internal (von Neumann) RAM.

## INTERRUPTS

The MSC1212 uses a three-priority interrupt system. As shown in Table IX, each interrupt source has an independent priority bit, flag, interrupt vector, and enable (except that nine interrupts share the Auxiliary Interrupt (AI) at the highest priority). In addition, interrupts can be globally enabled or disabled. The interrupt structure is compatible with the original 8051 family. All of the standard interrupts are available.

## HARDWARE CONFIGURATION MEMORY

The 128 configuration bytes can only be written during the program mode. The bytes are accessed through SFR registers CADDR (SFR 93<sub>H</sub>) and CDATA (SFR 94<sub>H</sub>). Two of the configuration bytes control Flash partitioning and system control. If the security bit is set, these bits can not be changed except with a Mass Erase command that erases all of the Flash Memory including the 128 configuration bytes.

| INTERRUPT/EVENT                            | INTERRUPT       |     | PRIORITY | FLAG   | PRIORITY ENABLE  | CONTROL     |
|--|-----------------|-----|----------|--|--|-------------|
|  | ADDR            | NUM |          |  |  |             |
| DV <sub>DD</sub> Low Voltage/HW Breakpoint | 33 <sub>H</sub> | 6   | HIGH     | EDLVB (AIE.0) <sup>(1)</sup><br>EBP (BPCON.0) <sup>(1)</sup> | EDLVV (AIE.0) <sup>(1)</sup><br>EBP (BPCON.0) <sup>(1)</sup> | N/A         |
| AV <sub>DD</sub> Low Voltage               | 33 <sub>H</sub> | 6   | 0        | EALV (AIE.1) <sup>(1)</sup>                                  | EALV (AIE.1) <sup>(1)</sup>                                  | N/A         |
| SPI Receive                                | 33 <sub>H</sub> | 6   | 0        | ESPIR (AIE.2) <sup>(1)</sup>                                 | ESPIR (AIE.2) <sup>(1)</sup>                                 | N/A         |
| SPI Transmit                               | 33 <sub>H</sub> | 6   | 0        | ESPIT (AIE.3) <sup>(1)</sup>                                 | ESPIT (AIE.3) <sup>(1)</sup>                                 | N/A         |
| Milliseconds Timer                         | 33 <sub>H</sub> | 6   | 0        | EMSEC (AIE.4) <sup>(1)</sup>                                 | EMSEC (AIE.4) <sup>(1)</sup>                                 | N/A         |
| ADC  | 33 <sub>H</sub> | 6   | 0        | EADC (AIE.5) <sup>(1)</sup>                                  | EADC (AIE.5) <sup>(1)</sup>                                  | N/A         |
| Summation Register                         | 33 <sub>H</sub> | 6   | 0        | ESUM (AIE.6) <sup>(1)</sup>                                  | ESUM (AIE.6) <sup>(1)</sup>                                  | N/A         |
| Seconds Timer                              | 33 <sub>H</sub> | 6   | 0        | ESEC (AIE.7) <sup>(1)</sup>                                  | ESEC (AIE.7) <sup>(1)</sup>                                  | N/A         |
| External Interrupt 0                       | 03 <sub>H</sub> | 0   | 1        | IE0 (TCON.1) <sup>(2)</sup>                                  | EX0 (IE.0) <sup>(4)</sup>                                    | PX0 (IP.0)  |
| Timer 0 Overflow                           | 0B <sub>H</sub> | 1   | 2        | TF0 (TCON.5) <sup>(3)</sup>                                  | ET0 (IE.1) <sup>(4)</sup>                                    | PT0 (IP.1)  |
| External Interrupt 1                       | 13 <sub>H</sub> | 2   | 3        | IE1 (TCON.3) <sup>(2)</sup>                                  | EX1 (IE.2) <sup>(4)</sup>                                    | PX1 (IP.2)  |
| Timer 1 Overflow                           | 1B <sub>H</sub> | 3   | 4        | TF1 (TCON.7) <sup>(3)</sup>                                  | ET1 (IE.3) <sup>(4)</sup>                                    | PT1 (IP.3)  |
| Serial Port 0                              | 23 <sub>H</sub> | 4   | 5        | RI_0 (SCON0.0)<br>TI_0 (SCON0.1)                             | ES0 (IE.4) <sup>(4)</sup>                                    | PS0 (IP.4)  |
| Timer 2 Overflow                           | 2B <sub>H</sub> | 5   | 6        | TF2 (T2CON.7)  | ET2 (IE.5) <sup>(4)</sup>                                    | PT2 (IP.5)  |
| Serial Port 1                              | 3B <sub>H</sub> | 7   | 7        | RI_1 (SCON1.0)<br>TI_1 (SCON1.1)                             | ES1 (IE.6) <sup>(4)</sup>                                    | PS1 (IP.6)  |
| External Interrupt 2                       | 43 <sub>H</sub> | 8   | 8        | IE2 (EXIF.4)   | EX2 (EIE.0) <sup>(4)</sup>                                   | PX2 (IP.0)  |
| External Interrupt 3                       | 4B <sub>H</sub> | 9   | 9        | IE3 (EXIF.5)   | EX3 (EIE.1) <sup>(4)</sup>                                   | PX3 (IP.1)  |
| External Interrupt 4                       | 53 <sub>H</sub> | 10  | 10       | IE4 (EXIF.6)   | EX4 (EIE.2) <sup>(4)</sup>                                   | PX4 (IP.2)  |
| External Interrupt 5                       | 5B <sub>H</sub> | 11  | 11       | IE5 (EXIF.7)   | EX5 (EIE.3) <sup>(4)</sup>                                   | PX5 (IP.3)  |
| Watchdog                                   | 63 <sub>H</sub> | 12  | LOW      | WDTI (EICON.3)   | EWDI (EIE.4) <sup>(4)</sup>                                  | PWDI (IP.4) |

NOTES: (1) These interrupts set the AI flag (EICON.4) and are enabled by EAI (EICON.5). (2) If edge triggered, cleared automatically by hardware when the service routine is vectored to. If level triggered, the flag follows the state of the pin. (3) Cleared automatically by hardware when interrupt vector occurs. (4) Globally enabled by EA (IE.7).

TABLE IX. Interrupt Summary.

## Hardware Configuration Register 0 (HCR0)—Accessed Using SFR Registers CADDR and CDATA.

|                       | bit 7 | bit 6 | bit 5 | bit 4 | bit 3 | bit 2  | bit 1  | bit 0  |
|-----------------------|-------|-------|-------|-------|-------|--------|--------|--------|
| CADDR 7F <sub>H</sub> | EPMA  | PML   | RSL   | EBR   | EWDR  | DFSEL2 | DFSEL1 | DFSEL0 |

For access to this register during normal operation, refer to the register descriptions for CADDR and CDATA.

### **EPMA Enable Programming Memory Access (Security Bit).**

bit 7 0: After reset in programming modes, Flash Memory can only be accessed in UAM mode until a mass erase is done.  
1: Fully Accessible (default)

### **PML Program Memory Lock. (PML has Priority Over RSL)**

bit 6 0: Enable all Flash Programming Modes in program mode, can be written in UAM.  
1: Enable read only for program mode, can't be written in UAM (default).

### **RSL Reset Sector Lock.**

bit 5 0: Enable Reset Sector Writing  
1: Enable Read Only Mode for Reset Sector (4kB) (default)

### **EBR Enable Boot Rom.** Boot Rom is 2kB of code located in ROM, not to be confused with the 4kB Boot Sector located in Flash Memory.

bit 4 0: Disable Internal Boot Rom  
1: Enable Internal Boot Rom (default)

### **EWDR Enable Watchdog Reset.**

bit 3 0: Disable Watchdog Reset  
1: Enable Watchdog Reset (default)

### **DFSEL Data Flash Memory Size. (see Table III)**

bits 2-0 000: Reserved  
001: 32kB, 16kB, 8kB, or 4kB Data Flash Memory  
010: 16kB, 8kB, or 4kB Data Flash Memory  
011: 8kB or 4kB Data Flash Memory  
100: 4kB Data Flash Memory  
101: 2kB Data Flash Memory  
110: 1kB Data Flash Memory  
111: No Data Flash Memory (default)

The reset sector can be used to provide another method of Flash Memory programming. This will allow Program Memory updates without changing the jumpers for in-circuit code updates or program development. The code in this boot sector would then provide the monitor and programming routines with the ability to jump into the main Flash code when programming is finished.

## Hardware Configuration Register 1 (HCR1)

|                       | 7       | 6       | 5       | 4       | 3   | 2   | 1    | 0     |
|-----------------------|---------|---------|---------|---------|-----|-----|------|-------|
| CADDR 7E <sub>H</sub> | DBLSEL1 | DBLSEL0 | ABLSEL1 | ABLSEL0 | DAB | DDB | EGP0 | EGP23 |

For access to this register during normal operation, refer to the register descriptions for CADDR and CDATA.

### **DBLSEL Digital Brownout Level Select**

bits 7-6 00: 4.5V  
01: 4.2V  
10: 2.7V  
11: 2.5V (default)

### **ABLSEL Analog Brownout Level Select**

bits 5-4 00: 4.5V  
01: 4.2V  
10: 2.7V  
11: 2.5V (default)

### **DAB Disable Analog Power-Supply Brownout Detection**

bit 3 0: Enable Analog Brownout Detection  
1: Disable Analog Brownout Detection (default).

### **DDB Disable Digital Power-Supply Brownout Detection**

bit 2 0: Enable Digital Brownout Detection  
1: Disable Digital Brownout Detection (default)

### **EGP0 Enable General-Purpose I/O for Port 0**

bit 1 0: Port 0 is Used for External Memory, P3.6 and P3.7 Used for  $\overline{WR}$  and  $\overline{RD}$ .  
1: Port 0 is Used as General-Purpose I/O (default)

### **EGP23 Enable General-Purpose I/O for Ports 2 and 3**

bit 0 0: Port 2 is Used for External Memory, P3.6 and P3.7 Used for  $\overline{WR}$  and  $\overline{RD}$ .  
1: Port 2 and Port3 are Used as General-Purpose I/O (default)

## **Configuration Memory Programming**

Certain key functions such as Brownout Reset and Watchdog Timer are controlled by the hardware configuration bits. These bits are nonvolatile and can only be changed through serial and parallel programming. Other peripheral control and status functions, such as ADC configuration timer setup, and Flash control are controlled through the SFRs.

## SFR Definitions (Boldface is unique to the MSC1212)

| ADDRESS         | REGISTER          | BIT 7                   | BIT 6                   | BIT 5                   | BIT 4                   | BIT 3                   | BIT 2                   | BIT 1                 | BIT 0                 | RESET VALUES          |                 |
|-----------------|-------------------|-------------------------|-------------------------|-------------------------|-------------------------|-------------------------|-------------------------|-----------------------|-----------------------|-----------------------|-----------------|
| 80 <sub>H</sub> | P0                | P0.7                    | P0.6                    | P0.5                    | P0.4                    | P0.3                    | P0.2                    | P0.1                  | P0.0                  | FF <sub>H</sub>       |                 |
| 81 <sub>H</sub> | SP                |                         |                         |                         |                         |                         |                         |                       |                       | 07 <sub>H</sub>       |                 |
| 82 <sub>H</sub> | DPL0              |                         |                         |                         |                         |                         |                         |                       |                       | 00 <sub>H</sub>       |                 |
| 83 <sub>H</sub> | DPH0              |                         |                         |                         |                         |                         |                         |                       |                       | 00 <sub>H</sub>       |                 |
| 84 <sub>H</sub> | DPL1              |                         |                         |                         |                         |                         |                         |                       |                       | 00 <sub>H</sub>       |                 |
| 85 <sub>H</sub> | DPH1              |                         |                         |                         |                         |                         |                         |                       |                       | 00 <sub>H</sub>       |                 |
| 86 <sub>H</sub> | DPS               | <b>0</b>                | <b>0</b>                | <b>0</b>                | <b>0</b>                | <b>0</b>                | <b>0</b>                | <b>0</b>              | <b>SEL</b>            | <b>00<sub>H</sub></b> |                 |
| 87 <sub>H</sub> | PCON              | <b>SMOD</b>             | <b>0</b>                | <b>1</b>                | <b>1</b>                | <b>GF1</b>              | <b>GF0</b>              | <b>STOP</b>           | <b>IDLE</b>           | <b>30<sub>H</sub></b> |                 |
| 88 <sub>H</sub> | TCON              | TF1                     | TR1                     | TF0                     | TR0                     | IE1                     | IT1                     | IE0                   | IT0                   | 00 <sub>H</sub>       |                 |
| 89 <sub>H</sub> | TMOD              | -----Timer 1 -----      |                         |                         |                         | -----Timer 0 -----      |                         |                       |                       |                       | 00 <sub>H</sub> |
|                 |                   | GATE                    | C/ $\bar{T}$            | M1                      | M0                      | GATE                    | C/ $\bar{T}$            | M1                    | M0                    |                       |                 |
| 8A <sub>H</sub> | TL0               |                         |                         |                         |                         |                         |                         |                       |                       | 00 <sub>H</sub>       |                 |
| 8B <sub>H</sub> | TL1               |                         |                         |                         |                         |                         |                         |                       |                       | 00 <sub>H</sub>       |                 |
| 8C <sub>H</sub> | TH0               |                         |                         |                         |                         |                         |                         |                       |                       | 00 <sub>H</sub>       |                 |
| 8D <sub>H</sub> | TH1               |                         |                         |                         |                         |                         |                         |                       |                       | 00 <sub>H</sub>       |                 |
| 8E <sub>H</sub> | CKCON             | <b>0</b>                | <b>0</b>                | <b>T2M</b>              | <b>T1M</b>              | <b>T0M</b>              | <b>MD2</b>              | <b>MD1</b>            | <b>MD0</b>            | <b>01<sub>H</sub></b> |                 |
| 8F <sub>H</sub> | MWS               | <b>0</b>                | <b>0</b>                | <b>0</b>                | <b>0</b>                | <b>0</b>                | <b>0</b>                | <b>0</b>              | <b>MXWS</b>           | <b>00<sub>H</sub></b> |                 |
| 90 <sub>H</sub> | P1                | P1.7<br>INT5/SCLK       | P1.6<br>INT4/MISO       | P1.5<br>INT3/MOSI       | P1.4<br>INT2/SS         | P1.3<br>TXD1            | P1.2<br>RXD1            | P1.1<br>T2EX          | P1.0<br>T2            | FF <sub>H</sub>       |                 |
| 91 <sub>H</sub> | EXIF              | IE5                     | IE4                     | IE3                     | IE2                     | 1                       | 0                       | 0                     | 0                     | 08 <sub>H</sub>       |                 |
| 92 <sub>H</sub> | MPAGE             |                         |                         |                         |                         |                         |                         |                       |                       | 00 <sub>H</sub>       |                 |
| 93 <sub>H</sub> | CADDR             |                         |                         |                         |                         |                         |                         |                       |                       | 00 <sub>H</sub>       |                 |
| 94 <sub>H</sub> | CDATA             |                         |                         |                         |                         |                         |                         |                       |                       | 00 <sub>H</sub>       |                 |
| 95 <sub>H</sub> | MCON              | <b>BPSEL</b>            | <b>0</b>                | <b>0</b>                |                         |                         |                         |                       | <b>RAMMAP</b>         | <b>00<sub>H</sub></b> |                 |
| 96 <sub>H</sub> |                   |                         |                         |                         |                         |                         |                         |                       |                       |                       |                 |
| 97 <sub>H</sub> |                   |                         |                         |                         |                         |                         |                         |                       |                       |                       |                 |
| 98 <sub>H</sub> | SCON0             | SM0_0                   | SM1_0                   | SM2_0                   | REN_0                   | TB8_0                   | RB8_0                   | TL_0                  | RI_0                  | 00 <sub>H</sub>       |                 |
| 99 <sub>H</sub> | SBUF0             |                         |                         |                         |                         |                         |                         |                       |                       | 00 <sub>H</sub>       |                 |
| 9A <sub>H</sub> | SPICON            | <b>SCLK2</b>            | <b>SCLK1</b>            | <b>SCLK0</b>            | <b>FIFO</b>             | <b>ORDER</b>            | <b>MSTR</b>             | <b>CPHA</b>           | <b>CPOL</b>           | <b>00<sub>H</sub></b> |                 |
| 9B <sub>H</sub> | SPIDATA           |                         |                         |                         |                         |                         |                         |                       |                       | 00 <sub>H</sub>       |                 |
| 9C <sub>H</sub> | SPIRCON           | RXCNT7<br>RXFLUSH       | RXCNT6                  | RXCNT5                  | RXCNT4                  | RXCNT3                  | RXCNT2<br>RXIRQ2        | RXCNT1<br>RXIRQ1      | RXCNT0<br>RXIRQ0      | 00 <sub>H</sub>       |                 |
| 9D <sub>H</sub> | SPITCON           | TXCNT7<br>TXFLUSH       | TXCNT6                  | TXCNT5<br>CLK_EN        | TXCNT4<br>DRV_DLY       | TXCNT3<br>DRV_EN        | TXCNT2<br>TXIRQ2        | TXCNT1<br>TXIRQ1      | TXCNT0<br>TXIRQ0      | 00 <sub>H</sub>       |                 |
| 9E <sub>H</sub> | SPISTART          | 1                       |                         |                         |                         |                         |                         |                       |                       | 80 <sub>H</sub>       |                 |
| 9F <sub>H</sub> | SPIEND            | 1                       |                         |                         |                         |                         |                         |                       |                       | 80 <sub>H</sub>       |                 |
| A0 <sub>H</sub> | P2                | P2.7                    | P2.6                    | P2.5                    | P2.4                    | P2.3                    | P2.2                    | P2.1                  | P2.0                  | FF <sub>H</sub>       |                 |
| A1 <sub>H</sub> | PWMCON            |                         |                         | <b>PPOL</b>             | <b>PWMSEL</b>           | <b>SPDSEL</b>           | <b>TPCNTL2</b>          | <b>TPCNTL1</b>        | <b>TPCNTL0</b>        | <b>00<sub>H</sub></b> |                 |
| A2 <sub>H</sub> | PWMLow<br>TONELOW | <b>PWM7<br/>TDIV7</b>   | <b>PWM6<br/>TDIV6</b>   | <b>PWM5<br/>TDIV5</b>   | <b>PWM4<br/>TDIV4</b>   | <b>PWM3<br/>TDIV3</b>   | <b>PWM2<br/>TDIV2</b>   | <b>PWM1<br/>TDIV1</b> | <b>PWM0<br/>TDIV0</b> | <b>00<sub>H</sub></b> |                 |
| A3 <sub>H</sub> | PWMHI<br>TONEHI   | <b>PWM15<br/>TDIV15</b> | <b>PWM14<br/>TDIV14</b> | <b>PWM13<br/>TDIV13</b> | <b>PWM12<br/>TDIV12</b> | <b>PWM11<br/>TDIV11</b> | <b>PWM10<br/>TDIV10</b> | <b>PWM9<br/>TDIV9</b> | <b>PWM8<br/>TDIV8</b> | <b>00<sub>H</sub></b> |                 |
| A4 <sub>H</sub> |                   |                         |                         |                         |                         |                         |                         |                       |                       |                       |                 |
| A5 <sub>H</sub> | PAI               | <b>0</b>                | <b>0</b>                | <b>0</b>                | <b>0</b>                | <b>PAI3</b>             | <b>PAI2</b>             | <b>PAI1</b>           | <b>PAI0</b>           | <b>00<sub>H</sub></b> |                 |
| A6 <sub>H</sub> | AIE               | <b>ESEC</b>             | <b>ESUM</b>             | <b>EADC</b>             | <b>EMSEC</b>            | <b>ESPIT</b>            | <b>ESPIR</b>            | <b>EALV</b>           | <b>EDLVB</b>          | <b>00<sub>H</sub></b> |                 |
| A7 <sub>H</sub> | AISTAT            | <b>SEC</b>              | <b>SUM</b>              | <b>ADC</b>              | <b>MSEC</b>             | <b>SPIT</b>             | <b>SPIR</b>             | <b>ALVD</b>           | <b>DLVD</b>           | <b>00<sub>H</sub></b> |                 |
| A8 <sub>H</sub> | IE                | EA                      | ES1                     | ET2                     | ES0                     | ET1                     | EX1                     | ET0                   | EX0                   | 00 <sub>H</sub>       |                 |
| A9 <sub>H</sub> | BPCON             | <b>BP</b>               | <b>0</b>                | <b>0</b>                | <b>0</b>                | <b>0</b>                | <b>0</b>                | <b>PMSSEL</b>         | <b>EBP</b>            | <b>00<sub>H</sub></b> |                 |
| AA <sub>H</sub> | BPL               |                         |                         |                         |                         |                         |                         |                       |                       |                       |                 |
| AB <sub>H</sub> | BPH               |                         |                         |                         |                         |                         |                         |                       |                       |                       |                 |
| AC <sub>H</sub> | P0DDRl            | P03H                    | P03L                    | P02H                    | P02L                    | P01H                    | P01L                    | P00H                  | P00L                  | 00 <sub>H</sub>       |                 |
| AD <sub>H</sub> | P0DDRH            | P07H                    | P07L                    | P06H                    | P06L                    | P05H                    | P05L                    | P04H                  | P04L                  | 00 <sub>H</sub>       |                 |
| AE <sub>H</sub> | P1DDRl            | P13H                    | P13L                    | P12H                    | P12L                    | P11H                    | P11L                    | P10H                  | P10L                  | 00 <sub>H</sub>       |                 |
| AF <sub>H</sub> | P1DDRH            | P17H                    | P17L                    | P16H                    | P16L                    | P15H                    | P15L                    | P14H                  | P14L                  | 00 <sub>H</sub>       |                 |
| B0 <sub>H</sub> | P3                | P3.7<br>RD              | P3.6<br>WR              | P3.5<br>T1              | P3.4<br>T0              | P3.3<br>INT1            | P3.2<br>INT0            | P3.1<br>TXD0          | P3.0<br>RXD0          | FF <sub>H</sub>       |                 |
| B1 <sub>H</sub> | P2DDRl            | P23H                    | P23L                    | P22H                    | P22L                    | P21H                    | P21L                    | P20H                  | P20L                  | 00 <sub>H</sub>       |                 |
| B2 <sub>H</sub> | P2DDRH            | P27H                    | P27L                    | P26H                    | P26L                    | P25H                    | P25L                    | P24H                  | P24L                  | 00 <sub>H</sub>       |                 |
| B3 <sub>H</sub> | P3DDRl            | P33H                    | P33L                    | P32H                    | P32L                    | P31H                    | P31L                    | P30H                  | P30L                  | 00 <sub>H</sub>       |                 |
| B4 <sub>H</sub> | P3DDRH            | P37H                    | P37L                    | P36H                    | P36L                    | P35H                    | P35L                    | P34H                  | P34L                  | 00 <sub>H</sub>       |                 |
| B5 <sub>H</sub> | DAcL              |                         |                         |                         |                         |                         |                         |                       |                       |                       |                 |
| B6 <sub>H</sub> | DAcH              |                         |                         |                         |                         |                         |                         |                       |                       |                       |                 |
| B7 <sub>H</sub> | DACCON            | <b>DSEL7</b>            | <b>DSEL6</b>            | <b>DSEL5</b>            | <b>DSEL4</b>            | <b>DSEL3</b>            | <b>DSEL2</b>            | <b>DSEL1</b>          | <b>DSEL0</b>          | <b>00<sub>H</sub></b> |                 |
| B8 <sub>H</sub> | IP                | 1                       | PS1                     | PT2                     | PS0                     | PT1                     | PX1                     | PT0                   | PX0                   | 80 <sub>H</sub>       |                 |
| B9 <sub>H</sub> |                   |                         |                         |                         |                         |                         |                         |                       |                       |                       |                 |

| ADDRESS         | REGISTER | BIT 7  | BIT 6   | BIT 5   | BIT 4   | BIT 3   | BIT 2   | BIT 1       | BIT 0   | RESET VALUES           |
|-----------------|----------|--------|---------|---------|---------|---------|---------|-------------|---------|------------------------|
| BA <sub>H</sub> |          |        |         |         |         |         |         |             |         |                        |
| BB <sub>H</sub> |          |        |         |         |         |         |         |             |         |                        |
| BC <sub>H</sub> |          |        |         |         |         |         |         |             |         |                        |
| BD <sub>H</sub> |          |        |         |         |         |         |         |             |         |                        |
| BE <sub>H</sub> |          |        |         |         |         |         |         |             |         |                        |
| BF <sub>H</sub> |          |        |         |         |         |         |         |             |         |                        |
| C0 <sub>H</sub> | SCON1    | SM0_1  | SM1_1   | SM2_1   | REN_1   | TB8_1   | RB8_1   | TI_1        | RI_1    | 00 <sub>H</sub>        |
| C1 <sub>H</sub> | SBUF1    |        |         |         |         |         |         |             |         | 00 <sub>H</sub>        |
| C2 <sub>H</sub> |          |        |         |         |         |         |         |             |         |                        |
| C3 <sub>H</sub> |          |        |         |         |         |         |         |             |         |                        |
| C4 <sub>H</sub> |          |        |         |         |         |         |         |             |         |                        |
| C5 <sub>H</sub> |          |        |         |         |         |         |         |             |         |                        |
| C6 <sub>H</sub> | EWU      |        |         |         |         |         | EWUWDT  | EWUEX1      | EWUEX0  | 00 <sub>H</sub>        |
| C7 <sub>H</sub> | SYCLK    | 0      | 0       | DIVMOD1 | DIVMOD0 | 0       | DIV2    | DIV1        | DIV0    | 00 <sub>H</sub>        |
| C8 <sub>H</sub> | T2CON    | TF2    | EXF2    | RCLK    | TCLK    | EXEN2   | TR2     | C/T2        | CP/RL2  | 00 <sub>H</sub>        |
| C9 <sub>H</sub> |          |        |         |         |         |         |         |             |         |                        |
| CA <sub>H</sub> | RCAP2L   |        |         |         |         |         |         |             |         | 00 <sub>H</sub>        |
| CB <sub>H</sub> | RCAP2H   |        |         |         |         |         |         |             |         | 00 <sub>H</sub>        |
| CC <sub>H</sub> | TL2      |        |         |         |         |         |         |             |         | 00 <sub>H</sub>        |
| CD <sub>H</sub> | TH2      |        |         |         |         |         |         |             |         | 00 <sub>H</sub>        |
| CE <sub>H</sub> |          |        |         |         |         |         |         |             |         |                        |
| CF <sub>H</sub> |          |        |         |         |         |         |         |             |         |                        |
| D0 <sub>H</sub> | PSW      | CY     | AC      | F0      | RS1     | RS0     | OV      | F1          | P       | 00 <sub>H</sub>        |
| D1 <sub>H</sub> | OCL      |        |         |         |         |         |         |             | LSB     | 00 <sub>H</sub>        |
| D2 <sub>H</sub> | OCM      |        |         |         |         |         |         |             |         | 00 <sub>H</sub>        |
| D3 <sub>H</sub> | OCH      | MSB    |         |         |         |         |         |             |         | 00 <sub>H</sub>        |
| D4 <sub>H</sub> | GCL      |        |         |         |         |         |         |             | LSB     | 24 <sub>H</sub>        |
| D5 <sub>H</sub> | GCM      |        |         |         |         |         |         |             |         | 90 <sub>H</sub>        |
| D6 <sub>H</sub> | GCH      | MSB    |         |         |         |         |         |             |         | 67 <sub>H</sub>        |
| D7 <sub>H</sub> | ADMUX    | INP3   | INP2    | INP1    | INP0    | INN3    | INN2    | INN1        | INN0    | 01 <sub>H</sub>        |
| D8 <sub>H</sub> | EICON    | SMOD1  | 1       | EAI     | AI      | WDT1    | 0       | 0           | 0       | 40 <sub>H</sub>        |
| D9 <sub>H</sub> | ADRESL   |        |         |         |         |         |         |             | LSB     | 00 <sub>H</sub>        |
| DA <sub>H</sub> | ADRESM   |        |         |         |         |         |         |             |         | 00 <sub>H</sub>        |
| DB <sub>H</sub> | ADRESH   | MSB    |         |         |         |         |         |             |         | 00 <sub>H</sub>        |
| DC <sub>H</sub> | ADCON0   | —      | BOD     | EVREF   | VREFH   | EBUF    | PGA2    | PGA1        | PGA0    | 38 <sub>H</sub>        |
| DD <sub>H</sub> | ADCON1   | —      | POL     | SM1     | SM0     | —       | CAL2    | CAL1        | CAL0    | x000_0000 <sub>B</sub> |
| DE <sub>H</sub> | ADCON2   | DR7    | DR6     | DR5     | DR4     | DR3     | DR2     | DR1         | DR0     | 1B <sub>H</sub>        |
| DF <sub>H</sub> | ADCON3   | 0      | 0       | 0       | 0       | 0       | DR10    | DR9         | DR8     | 06 <sub>H</sub>        |
| E0 <sub>H</sub> | ACC      |        |         |         |         |         |         |             |         | 00 <sub>H</sub>        |
| E1 <sub>H</sub> | SSCON    | SSCON1 | SSCON0  | SCNT2   | SCNT1   | SCNT0   | SHF2    | SHF1        | SHF0    | 00 <sub>H</sub>        |
| E2 <sub>H</sub> | SUMR0    |        |         |         |         |         |         |             |         | 00 <sub>H</sub>        |
| E3 <sub>H</sub> | SUMR1    |        |         |         |         |         |         |             |         | 00 <sub>H</sub>        |
| E4 <sub>H</sub> | SUMR2    |        |         |         |         |         |         |             |         | 00 <sub>H</sub>        |
| E5 <sub>H</sub> | SUMR3    |        |         |         |         |         |         |             |         | 00 <sub>H</sub>        |
| E6 <sub>H</sub> | ODAC     |        |         |         |         |         |         |             |         | 00 <sub>H</sub>        |
| E7 <sub>H</sub> | LVDCON   | ALVDIS | ALVD2   | ALVD1   | ALVD0   | DLVDIS  | DLVD2   | DLVD1       | DLVD0   | 00 <sub>H</sub>        |
| E8 <sub>H</sub> | EIE      | 1      | 1       | 1       | EWDI    | EX5     | EX4     | EX3         | EX2     | E0 <sub>H</sub>        |
| E9 <sub>H</sub> | HWPC0    |        |         |         |         |         | 1       | MEMORY SIZE |         | 0000_01xx <sub>B</sub> |
| EA <sub>H</sub> | HWPC1    |        |         |         |         | 1       |         |             |         | 08 <sub>H</sub>        |
| EB <sub>H</sub> | HWVER    |        |         |         |         |         |         |             |         |                        |
| EC <sub>H</sub> | Reserved |        |         |         |         |         |         |             |         | 00 <sub>H</sub>        |
| ED <sub>H</sub> | Reserved |        |         |         |         |         |         |             |         | 00 <sub>H</sub>        |
| EE <sub>H</sub> | FMCON    | 0      | PGERA   | 0       | FRCM    | 0       | BUSY    | 1           | 0       | 02 <sub>H</sub>        |
| EF <sub>H</sub> | FTCON    | FER3   | FER2    | FER1    | FER0    | FWR3    | FWR2    | FWR1        | FWR0    | A5 <sub>H</sub>        |
| F0 <sub>H</sub> | B        |        |         |         |         |         |         |             |         | 00 <sub>H</sub>        |
| F1 <sub>H</sub> | PDCON    | 0      | PDDAC   | 1       | PDPWM   | PDAD    | PDWDT   | PDST        | PDSPI   | 7F <sub>H</sub>        |
| F2 <sub>H</sub> | PASEL    | 0      | 0       | PSEN2   | PSEN1   | PSEN0   | 0       | ALE1        | ALE0    | 00 <sub>H</sub>        |
| F3 <sub>H</sub> |          |        |         |         |         |         |         |             |         |                        |
| F4 <sub>H</sub> |          |        |         |         |         |         |         |             |         |                        |
| F5 <sub>H</sub> |          |        |         |         |         |         |         |             |         |                        |
| F6 <sub>H</sub> | ACLK     | 0      | FREQ6   | FREQ5   | FREQ4   | FREQ3   | FREQ2   | FREQ1       | FREQ0   | 03 <sub>H</sub>        |
| F7 <sub>H</sub> | SRST     | 0      | 0       | 0       | 0       | 0       | 0       | 0           | RSTREQ  | 00 <sub>H</sub>        |
| F8 <sub>H</sub> | EIP      | 1      | 1       | 1       | PWDI    | PX5     | PX4     | PX3         | PX2     | E0 <sub>H</sub>        |
| F9 <sub>H</sub> | SECINT   | WRT    | SECINT6 | SECINT5 | SECINT4 | SECINT3 | SECINT2 | SECINT1     | SECINT0 | 7F <sub>H</sub>        |
| FA <sub>H</sub> | MSINT    | WRT    | MSINT6  | MSINT5  | MSINT4  | MSINT3  | MSINT2  | MSINT1      | MSINT0  | 7F <sub>H</sub>        |
| FB <sub>H</sub> | USEC     | 0      | 0       | FREQ5   | FREQ4   | FREQ3   | FREQ2   | FREQ1       | FREQ0   | 03 <sub>H</sub>        |
| FC <sub>H</sub> | MSECL    |        |         |         |         |         |         |             |         | 9F <sub>H</sub>        |
| FD <sub>H</sub> | MSECH    |        |         |         |         |         |         |             |         | 0F <sub>H</sub>        |
| FE <sub>H</sub> | HMSEC    |        |         |         |         |         |         |             |         | 63 <sub>H</sub>        |
| FF <sub>H</sub> | WDTCON   | EWDT   | DWDT    | RWDT    | WDCNT4  | WDCNT3  | WDCNT2  | WDCNT1      | WDCNT0  | 00 <sub>H</sub>        |

## Port 0 (P0)

|                     | 7    | 6    | 5    | 4    | 3    | 2    | 1    | 0    | Reset Value     |
|---------------------|------|------|------|------|------|------|------|------|-----------------|
| SFR 80 <sub>H</sub> | P0.7 | P0.6 | P0.5 | P0.4 | P0.3 | P0.2 | P0.1 | P0.0 | FF <sub>H</sub> |

**P0.7-0** bits 7-0 **Port 0.** This port functions as a multiplexed address/data bus during external memory access, and as a general-purpose I/O port when external memory access is not needed. During external memory cycles, this port will contain the LSB of the address when ALE is HIGH, and Data when ALE is LOW. When used as a general-purpose I/O, this port drive is selected by P0DDR<sub>L</sub> and P0DDR<sub>H</sub> (AC<sub>H</sub>, AD<sub>H</sub>). Whether Port 0 is used as general-purpose I/O or for external memory access is determined by the Flash Configuration Register (HCR1.1) (see SFR CADDR 93<sub>H</sub>).

## Stack Pointer (SP)

|                     | 7    | 6    | 5    | 4    | 3    | 2    | 1    | 0    | Reset Value     |
|---------------------|------|------|------|------|------|------|------|------|-----------------|
| SFR 81 <sub>H</sub> | SP.7 | SP.6 | SP.5 | SP.4 | SP.3 | SP.2 | SP.1 | SP.0 | 07 <sub>H</sub> |

**SP.7-0** bits 7-0 **Stack Pointer.** The stack pointer identifies the location where the stack will begin. The stack pointer is incremented before every PUSH or CALL operation and decremented after each POP or RET/RETI. This register defaults to 07<sub>H</sub> after reset.

## Data Pointer Low 0 (DPL0)

|                     | 7      | 6      | 5      | 4      | 3      | 2      | 1      | 0      | Reset Value     |
|---------------------|--------|--------|--------|--------|--------|--------|--------|--------|-----------------|
| SFR 82 <sub>H</sub> | DPL0.7 | DPL0.6 | DPL0.5 | DPL0.4 | DPL0.3 | DPL0.2 | DPL0.1 | DPL0.0 | 00 <sub>H</sub> |

**DPL0.7-0** bits 7-0 **Data Pointer Low 0.** This register is the low byte of the standard 8051 16-bit data pointer. DPL0 and DPH0 are used to point to non-scratchpad data RAM. The current data pointer is selected by DPS (SFR 86<sub>H</sub>).

## Data Pointer High 0 (DPH0)

|                     | 7      | 6      | 5      | 4      | 3      | 2      | 1      | 0      | Reset Value     |
|---------------------|--------|--------|--------|--------|--------|--------|--------|--------|-----------------|
| SFR 83 <sub>H</sub> | DPH0.7 | DPH0.6 | DPH0.5 | DPH0.4 | DPH0.3 | DPH0.2 | DPH0.1 | DPH0.0 | 00 <sub>H</sub> |

**DPH0.7-0** bits 7-0 **Data Pointer High 0.** This register is the high byte of the standard 8051 16-bit data pointer. DPL0 and DPH0 are used to point to non-scratchpad data RAM. The current data pointer is selected by DPS (SFR 86<sub>H</sub>).

## Data Pointer Low 1 (DPL1)

|                     | 7      | 6      | 5      | 4      | 3      | 2      | 1      | 0      | Reset Value     |
|---------------------|--------|--------|--------|--------|--------|--------|--------|--------|-----------------|
| SFR 84 <sub>H</sub> | DPL1.7 | DPL1.6 | DPL1.5 | DPL1.4 | DPL1.3 | DPL1.2 | DPL1.1 | DPL1.0 | 00 <sub>H</sub> |

**DPL1.7-0** bits 7-0 **Data Pointer Low 1.** This register is the low byte of the auxiliary 16-bit data pointer. When the SEL bit (DPS.0) (SFR 86<sub>H</sub>) is set, DPL1 and DPH1 are used in place of DPL0 and DPH0 during DPTR operations.

## Data Pointer High 1 (DPH1)

|                     | 7      | 6      | 5      | 4      | 3      | 2      | 1      | 0      | Reset Value     |
|---------------------|--------|--------|--------|--------|--------|--------|--------|--------|-----------------|
| SFR 85 <sub>H</sub> | DPH1.7 | DPH1.6 | DPH1.5 | DPH1.4 | DPH1.3 | DPH1.2 | DPH1.1 | DPH1.0 | 00 <sub>H</sub> |

**DPH1.7-0** bits 7-0 **Data Pointer High 1.** This register is the high byte of the auxiliary 16-bit data pointer. When the SEL bit (DPS.0) (SFR 86<sub>H</sub>) is set, DPL1 and DPH1 are used in place of DPL0 and DPH0 during DPTR operations.

## Data Pointer Select (DPS)

|                     | 7 | 6 | 5 | 4 | 3 | 2 | 1 | 0   | Reset Value     |
|---------------------|---|---|---|---|---|---|---|-----|-----------------|
| SFR 86 <sub>H</sub> | 0 | 0 | 0 | 0 | 0 | 0 | 0 | SEL | 00 <sub>H</sub> |

**SEL** bit 0 **Data Pointer Select.** This bit selects the active data pointer.  
0: Instructions that use the DPTR will use DPL0 and DPH0.  
1: Instructions that use the DPTR will use DPL1 and DPH1.

## Power Control (PCON)

|                     | 7    | 6 | 5 | 4 | 3   | 2   | 1    | 0    | Reset Value     |
|---------------------|------|---|---|---|-----|-----|------|------|-----------------|
| SFR 87 <sub>H</sub> | SMOD | 0 | 1 | 1 | GF1 | GF0 | STOP | IDLE | 30 <sub>H</sub> |

- SMOD** **Serial Port 0 Baud Rate Doubler Enable.** The serial baud rate doubling function for Serial Port 0.  
bit 7  
0: Serial Port 0 baud rate will be a standard baud rate.  
1: Serial Port 0 baud rate will be double that defined by baud rate generation equation.
- GF1** **General-Purpose User Flag 1.** This is a general-purpose flag for software control.  
bit 3
- GF0** **General-Purpose User Flag 0.** This is a general-purpose flag for software control.  
bit 2
- STOP** **Stop Mode Select.** Setting this bit will halt the oscillator and block external clocks. This bit will always read as a 0. Exit with RESET.  
bit 1
- IDLE** **Idle Mode Select.** Setting this bit will freeze the CPU, Timer 0, 1, and 2, and the UARTs; other peripherals remain active. This bit will always be read as a 0. Exit with AI (A6<sub>H</sub>) and EWU (C6<sub>H</sub>) interrupts.  
bit 0

## Timer/Counter Control (TCON)

|                     | 7   | 6   | 5   | 4   | 3   | 2   | 1   | 0   | Reset Value     |
|---------------------|-----|-----|-----|-----|-----|-----|-----|-----|-----------------|
| SFR 88 <sub>H</sub> | TF1 | TR1 | TF0 | TR0 | IE1 | IT1 | IE0 | IT0 | 00 <sub>H</sub> |

- TF1** **Timer 1 Overflow Flag.** This bit indicates when Timer 1 overflows its maximum count as defined by the current mode. This bit can be cleared by software and is automatically cleared when the CPU vectors to the Timer 1 interrupt service routine.  
bit 7  
0: No Timer 1 overflow has been detected.  
1: Timer 1 has overflowed its maximum count.
- TR1** **Timer 1 Run Control.** This bit enables/disables the operation of Timer 1. Halting this timer will preserve the current bit 6 count in TH1, TL1.  
0: Timer is halted.  
1: Timer is enabled.
- TF0** **Timer 0 Overflow Flag.** This bit indicates when Timer 0 overflows its maximum count as defined by the current mode. This bit can be cleared by software and is automatically cleared when the CPU vectors to the Timer 0 interrupt service routine.  
bit 5  
0: No Timer 0 overflow has been detected.  
1: Timer 0 has overflowed its maximum count.
- TR0** **Timer 0 Run Control.** This bit enables/disables the operation of Timer 0. Halting this timer will preserve the current count in TH0, TL0.  
bit 4  
0: Timer is halted.  
1: Timer is enabled.
- IE1** **Interrupt 1 Edge Detect.** This bit is set when an edge/level of the type defined by IT1 is detected. If IT1 = 1, this bit will remain set until cleared in software or the start of the External Interrupt 1 service routine. If IT1 = 0, this bit will inversely reflect the state of the  $\overline{\text{INT1}}$  pin.  
bit 3
- IT1** **Interrupt 1 Type Select.** This bit selects whether the  $\overline{\text{INT1}}$  pin will detect edge or level triggered interrupts.  
bit 2  
0:  $\overline{\text{INT1}}$  is level triggered.  
1:  $\overline{\text{INT1}}$  is edge triggered.
- IE0** **Interrupt 0 Edge Detect.** This bit is set when an edge/level of the type defined by IT0 is detected. If IT0 = 1, this bit will remain set until cleared in software or the start of the External Interrupt 0 service routine. If IT0 = 0, this bit will inversely reflect the state of the  $\overline{\text{INT0}}$  pin.  
bit 3
- IT0** **Interrupt 0 Type Select.** This bit selects whether the  $\overline{\text{INT0}}$  pin will detect edge or level triggered interrupts.  
bit 2  
0:  $\overline{\text{INT0}}$  is level triggered.  
1:  $\overline{\text{INT0}}$  is edge triggered.

## Timer Mode Control (TMOD)

|                     |         |     |    |    |         |     |    |    |                                |
|---------------------|---------|-----|----|----|---------|-----|----|----|--------------------------------|
|                     | 7       | 6   | 5  | 4  | 3       | 2   | 1  | 0  | Reset Value<br>00 <sub>H</sub> |
|                     | TIMER 1 |     |    |    | TIMER 0 |     |    |    |                                |
| SFR 89 <sub>H</sub> | GATE    | C/T | M1 | M0 | GATE    | C/T | M1 | M0 |                                |

**GATE** **Timer 1 Gate Control.** This bit enables/disables the ability of Timer 1 to increment.  
bit 7 0: Timer 1 will clock when TR1 = 1, regardless of the state of pin  $\overline{INT1}$ .  
1: Timer 1 will clock only when TR1 = 1 and pin  $\overline{INT1}$  = 1.

**C/T** **Timer 1 Counter/Timer Select.**  
bit 6 0: Timer is incremented by internal clocks.  
1: Timer is incremented by pulses on T1 pin when TR1 (TCON.6, SFR 88<sub>H</sub>) is 1.

**M1, M0** **Timer 1 Mode Select.** These bits select the operating mode of Timer 1.  
bits 5-4

| M1 | M0 | MODE  |
|----|----|---|
| 0  | 0  | Mode 0: 8-bit counter with 5-bit prescale.      |
| 0  | 1  | Mode 1: 16 bits.                                |
| 1  | 0  | Mode 2: 8-bit counter with auto reload.         |
| 1  | 1  | Mode 3: Timer 1 is halted, but holds its count. |

**GATE** **Timer 0 Gate Control.** This bit enables/disables the ability of Timer 0 to increment.  
bit 3 0: Timer 0 will clock when TR0 = 1, regardless of the state of pin  $\overline{INT0}$  (software control).  
1: Timer 0 will clock only when TR0 = 1 and pin  $\overline{INT0}$  = 1 (hardware control).

**C/T** **Timer 0 Counter/Timer Select.**  
bit 2 0: Timer is incremented by internal clocks.  
1: Timer is incremented by pulses on pin T0 when TR0 (TCON.4, SFR 88<sub>H</sub>) is 1.

**M1, M0** **Timer 0 Mode Select.** These bits select the operating mode of Timer 0.  
bits 1-0

| M1 | M0 | MODE  |
|----|----|---|
| 0  | 0  | Mode 0: 8-bit counter with 5-bit prescale.      |
| 0  | 1  | Mode 1: 16 bits.                                |
| 1  | 0  | Mode 2: 8-bit counter with auto reload.         |
| 1  | 1  | Mode 3: Timer 1 is halted, but holds its count. |

## Timer 0 LSB (TL0)

|                     |       |       |       |       |       |       |       |       |                 |
|---------------------|-------|-------|-------|-------|-------|-------|-------|-------|-----------------|
|                     | 7     | 6     | 5     | 4     | 3     | 2     | 1     | 0     | Reset Value     |
| SFR 8A <sub>H</sub> | TL0.7 | TL0.6 | TL0.5 | TL0.4 | TL0.3 | TL0.2 | TL0.1 | TL0.0 | 00 <sub>H</sub> |

TL0.7-0 **Timer 0 LSB.** This register contains the least significant byte of Timer 0.  
bits 7-0

## Timer 1 LSB (TL1)

|                     |       |       |       |       |       |       |       |       |                 |
|---------------------|-------|-------|-------|-------|-------|-------|-------|-------|-----------------|
|                     | 7     | 6     | 5     | 4     | 3     | 2     | 1     | 0     | Reset Value     |
| SFR 8B <sub>H</sub> | TL1.7 | TL1.6 | TL1.5 | TL1.4 | TL1.3 | TL1.2 | TL1.1 | TL1.0 | 00 <sub>H</sub> |

TL1.7-0 **Timer 1 LSB.** This register contains the least significant byte of Timer 1.  
bits 7-0

## Timer 0 MSB (TH0)

|                     |       |       |       |       |       |       |       |       |                 |
|---------------------|-------|-------|-------|-------|-------|-------|-------|-------|-----------------|
|                     | 7     | 6     | 5     | 4     | 3     | 2     | 1     | 0     | Reset Value     |
| SFR 8C <sub>H</sub> | TH0.7 | TH0.6 | TH0.5 | TH0.4 | TH0.3 | TH0.2 | TH0.1 | TH0.0 | 00 <sub>H</sub> |

TH0.7-0 **Timer 0 MSB.** This register contains the most significant byte of Timer 0.  
bits 7-0

## Timer 1 MSB (TH1)

|                     |       |       |       |       |       |       |       |       |                 |
|---------------------|-------|-------|-------|-------|-------|-------|-------|-------|-----------------|
|                     | 7     | 6     | 5     | 4     | 3     | 2     | 1     | 0     | Reset Value     |
| SFR 8D <sub>H</sub> | TH1.7 | TH1.6 | TH1.5 | TH1.4 | TH1.3 | TH1.2 | TH1.1 | TH1.0 | 00 <sub>H</sub> |

**TH1.7-0** **Timer 1 MSB.** This register contains the most significant byte of Timer 1.  
bits 7-0

## Clock Control (CKCON)

|                     |   |   |     |     |     |     |     |     |                 |
|---------------------|---|---|-----|-----|-----|-----|-----|-----|-----------------|
|                     | 7 | 6 | 5   | 4   | 3   | 2   | 1   | 0   | Reset Value     |
| SFR 8E <sub>H</sub> | 0 | 0 | T2M | T1M | T0M | MD2 | MD1 | MD0 | 01 <sub>H</sub> |

**T2M** **Timer 2 Clock Select.** This bit controls the division of the system clock that drives Timer 2. This bit has no effect when the timer is in baud rate generator or clock output modes. Clearing this bit to 0 maintains 8051 compatibility. This bit has no effect on instruction cycle timing.

0: Timer 2 uses a divide by 12 of the crystal frequency.

1: Timer 2 uses a divide by 4 of the crystal frequency.

**T1M** **Timer 1 Clock Select.** This bit controls the division of the system clock that drives Timer 1. Clearing this bit to 0 maintains 8051 compatibility. This bit has no effect on instruction cycle timing.

0: Timer 1 uses a divide by 12 of the crystal frequency.

1: Timer 1 uses a divide by 4 of the crystal frequency.

**T0M** **Timer 0 Clock Select.** This bit controls the division of the system clock that drives Timer 0. Clearing this bit to 0 maintains 8051 compatibility. This bit has no effect on instruction cycle timing.

0: Timer 0 uses a divide by 12 of the crystal frequency.

1: Timer 0 uses a divide by 4 of the crystal frequency.

**MD2, MD1, MD0** **Stretch MOVX Select 2-0.** These bits select the time by which external MOVX cycles are to be stretched. This allows slower memory or peripherals to be accessed without using ports or manual software intervention. The for  $\overline{RD}$  or  $\overline{WR}$  strobe will be stretched by the specified interval, which will be transparent to the software except for the increased time to execute the MOVX instruction. All internal MOVX instructions on devices containing MOVX SRAM are performed at the 2 instruction cycle rate.

bits 2-0

| MD2 | MD1 | MD0 | STRETCH VALUE | MOVX DURATION                  | $\overline{RD}$ or $\overline{WR}$ STROBE WIDTH (SYS CLKs) | $\overline{RD}$ or $\overline{WR}$ STROBE WIDTH ( $\mu$ s) AT 12MHz |
|-----|-----|-----|---------------|--------------------------------|--|---|
| 0   | 0   | 0   | 0             | 2 Instruction Cycles           | 2  | 0.167   |
| 0   | 0   | 1   | 1             | 3 Instruction Cycles (default) | 4  | 0.333   |
| 0   | 1   | 0   | 2             | 4 Instruction Cycles           | 8  | 0.667   |
| 0   | 1   | 1   | 3             | 5 Instruction Cycles           | 12   | 1.000   |
| 1   | 0   | 0   | 4             | 6 Instruction Cycles           | 16   | 1.333   |
| 1   | 0   | 1   | 5             | 7 Instruction Cycles           | 20   | 1.667   |
| 1   | 1   | 0   | 6             | 8 Instruction Cycles           | 24   | 2.000   |
| 1   | 1   | 1   | 7             | 9 Instruction Cycles           | 28   | 2.333   |

## Memory Write Select (MWS)

|                     |   |   |   |   |   |   |   |      |                 |
|---------------------|---|---|---|---|---|---|---|------|-----------------|
|                     | 7 | 6 | 5 | 4 | 3 | 2 | 1 | 0    | Reset Value     |
| SFR 8F <sub>H</sub> | 0 | 0 | 0 | 0 | 0 | 0 | 0 | MXWS | 00 <sub>H</sub> |

**MXWS** **MOVX Write Select.** This allows writing to the internal Flash program memory.

bit 0

0: No writes are allowed to the internal Flash program memory.

1: Writing is allowed to the internal Flash program memory, unless PML (HCR0) or RSL (HCR0) are on.

## Port 1 (P1)

|                     | 7                 | 6                 | 5                 | 4               | 3            | 2            | 1            | 0          | Reset Value     |
|---------------------|-------------------|-------------------|-------------------|-----------------|--------------|--------------|--------------|------------|-----------------|
| SFR 90 <sub>H</sub> | P1.7<br>INT5/SCLK | P1.6<br>INT4/MISO | P1.5<br>INT3/MOSI | P1.4<br>INT2/SS | P1.3<br>TXD1 | P1.2<br>RXD1 | P1.1<br>T2EX | P1.0<br>T2 | FF <sub>H</sub> |

**P1.7-0** bits 7-0 **General-Purpose I/O Port 1.** This register functions as a general-purpose I/O port. In addition, all the pins have an alternative function listed below. Each of the functions is controlled by several other SFRs. The associated Port 1 latch bit must contain a logic '1' before the pin can be used in its alternate function capacity. To use the alternate function, set the appropriate mode in P1DDRL (SFR AE<sub>H</sub>), P1DDRH (SFR AF<sub>H</sub>).

**INT5/SCLK** bit 7 **External Interrupt 5.** A falling edge on this pin will cause an external interrupt 5 if enabled.  
**SPI Clock.** The master clock for SPI data transfers.

**INT4/MISO** bit 6 **External Interrupt 4.** A rising edge on this pin will cause an external interrupt 4 if enabled.  
**Master In Slave Out.** For SPI data transfers, this pin receives data for the master and transmits data from the slave.

**INT3/MOSI** bit 5 **External Interrupt 3.** A falling edge on this pin will cause an external interrupt 3 if enabled.  
**Master Out Slave In.** For SPI data transfers, this pin transmits master data and receives slave data.

**INT2/SS** bit 4 **External Interrupt 2.** A rising edge on this pin will cause an external interrupt 2 if enabled.  
**Slave Select.** During SPI operation, this pin provides the select signal for the slave device.

**TXD1** bit 3 **Serial Port 1 Transmit.** This pin transmits the serial Port 1 data in serial port modes 1, 2, 3, and emits the synchronizing clock in serial port mode 0.

**RXD1** bit 2 **Serial Port 1 Receive.** This pin receives the serial Port 1 data in serial port modes 1, 2, 3, and is a bidirectional data transfer pin in serial port mode 0.

**T2EX** bit 1 **Timer 2 Capture/Reload Trigger.** A 1 to 0 transition on this pin will cause the value in the T2 registers to be transferred into the capture registers if enabled by EXEN2 (T2CON.3, SFR C8<sub>H</sub>). When in auto-reload mode, a 1 to 0 transition on this pin will reload the Timer 2 registers with the value in RCAP2L and RCAP2H if enabled by EXEN2 (T2CON.3, SFR C8<sub>H</sub>).

**T2** bit 0 **Time 2 External Input.** A 1 to 0 transition on this pin will cause Timer 2 to increment or decrement depending on the timer configuration.

## External Interrupt Flag (EXIF)

|                     | 7   | 6   | 5   | 4   | 3 | 2 | 1 | 0 | Reset Value     |
|---------------------|-----|-----|-----|-----|---|---|---|---|-----------------|
| SFR 91 <sub>H</sub> | IE5 | IE4 | IE3 | IE2 | 1 | 0 | 0 | 0 | 08 <sub>H</sub> |

**IE5** bit 7 **External Interrupt 5 Flag.** This bit will be set when a falling edge is detected on  $\overline{\text{INT5}}$ . This bit must be cleared manually by software. Setting this bit in software will cause an interrupt if enabled.

**IE4** bit 6 **External Interrupt 4 Flag.** This bit will be set when a rising edge is detected on INT4. This bit must be cleared manually by software. Setting this bit in software will cause an interrupt if enabled.

**IE3** bit 5 **External Interrupt 3 Flag.** This bit will be set when a falling edge is detected on  $\overline{\text{INT3}}$ . This bit must be cleared manually by software. Setting this bit in software will cause an interrupt if enabled.

**IE2** bit 4 **External Interrupt 2 Flag.** This bit will be set when a rising edge is detected on INT2. This bit must be cleared manually by software. Setting this bit in software will cause an interrupt if enabled.

## Memory Page (MPAGE)

|                     | 7 | 6 | 5 | 4 | 3 | 2 | 1 | 0 | Reset Value     |
|---------------------|---|---|---|---|---|---|---|---|-----------------|
| SFR 92 <sub>H</sub> |   |   |   |   |   |   |   |   | 00 <sub>H</sub> |

**MPAGE** bits 7-0 The 8051 uses Port 2 for the upper 8 bits of the external data memory access by MOVX A@R<sub>i</sub> and MOVX @R<sub>i</sub>, A instructions. The MSC1212 uses register MPAGE instead of Port 2. To access external data memory using the MOVX A@R<sub>i</sub> and MOVX @R<sub>i</sub>, A instructions, the user should preload the upper byte of the address into MPAGE (versus preloading into P2 for the standard 8051).

### Configuration Address Register (CADDR) (write only)

|                     |   |   |   |   |   |   |   |   |                 |
|---------------------|---|---|---|---|---|---|---|---|-----------------|
|                     | 7 | 6 | 5 | 4 | 3 | 2 | 1 | 0 | Reset Value     |
| SFR 93 <sub>H</sub> |   |   |   |   |   |   |   |   | 00 <sub>H</sub> |

**CADDR** Configuration Address Register. This register supplies the address for reading bytes in the 128 bytes of Flash Configuration Memory. WARNING: If this register is written to while executing from Flash Memory, the CADDR register will be incorrect.

### Configuration Data Register (CDATA)

|                     |   |   |   |   |   |   |   |   |                 |
|---------------------|---|---|---|---|---|---|---|---|-----------------|
|                     | 7 | 6 | 5 | 4 | 3 | 2 | 1 | 0 | Reset Value     |
| SFR 94 <sub>H</sub> |   |   |   |   |   |   |   |   | 00 <sub>H</sub> |

**CDATA** Configuration Data Register. This register will contain the data in the 128 bytes of Flash Configuration Memory that is located at the last written address in the CADDR register. This is a read-only register.

### Memory Control (MCON)

|                     |       |   |   |   |   |   |   |        |                 |
|---------------------|-------|---|---|---|---|---|---|--------|-----------------|
|                     | 7     | 6 | 5 | 4 | 3 | 2 | 1 | 0      | Reset Value     |
| SFR 95 <sub>H</sub> | BPSEL | 0 | 0 | — | — | — | — | RAMMAP | 00 <sub>H</sub> |

**BPSEL** Breakpoint Address Selection  
 bit 7 Write: Select one of two Breakpoint registers: 0 or 1.  
 0: Select breakpoint register 0.  
 1: Select breakpoint register 1.  
 Read: Provides the Breakpoint register that created the last interrupt: 0 or 1.

**RAMMAP** Memory Map 1kB extended SRAM.  
 bit 0 0: Address is: 0000<sub>H</sub>-03FF<sub>H</sub> (default) (Data Memory)  
 1: Address is 8400<sub>H</sub>-87FF<sub>H</sub> (Data and Program Memory)

### Serial Port 0 Control (SCON0)

|                     |       |       |       |       |       |       |      |      |                 |
|---------------------|-------|-------|-------|-------|-------|-------|------|------|-----------------|
|                     | 7     | 6     | 5     | 4     | 3     | 2     | 1    | 0    | Reset Value     |
| SFR 98 <sub>H</sub> | SM0_0 | SM1_0 | SM2_0 | REN_0 | TB8_0 | RB8_0 | TI_0 | RI_0 | 00 <sub>H</sub> |

**SM0-2** Serial Port 0 Mode. These bits control the mode of serial Port 0. Modes 1, 2, and 3 have 1 start and 1 stop bit in addition to the 8 or 9 data bits.

| MODE             | SM0 | SM1 | SM2 | FUNCTION                                       | LENGTH  | PERIOD   |
|------------------|-----|-----|-----|--|---------|--|
| 0                | 0   | 0   | 0   | Synchronous                                    | 8 bits  | 12 p <sub>CLK</sub> <sup>(1)</sup>   |
| 0                | 0   | 0   | 1   | Synchronous                                    | 8 bits  | 4 p <sub>CLK</sub> <sup>(1)</sup>  |
| 1 <sup>(2)</sup> | 0   | 1   | x   | Asynchronous                                   | 10 bits | Timer 1 or 2 Baud Rate Equation  |
| 2                | 1   | 0   | 0   | Asynchronous                                   | 11 bits | 64 p <sub>CLK</sub> <sup>(1)</sup> (SMOD = 0)<br>32 p <sub>CLK</sub> <sup>(1)</sup> (SMOD = 1) |
| 2                | 1   | 0   | 1   | Asynchronous with Multiprocessor Communication | 11 bits | 64 p <sub>CLK</sub> <sup>(1)</sup> (SMOD = 0)<br>32 p <sub>CLK</sub> <sup>(1)</sup> (SMOD = 1) |
| 3 <sup>(2)</sup> | 1   | 1   | 0   | Asynchronous                                   | 11 bits | Timer 1 or 2 Baud Rate Equation  |
| 3 <sup>(2)</sup> | 1   | 1   | 1   | Asynchronous with Multiprocessor Communication | 11 bits | Timer 1 or 2 Baud Rate Equation  |

NOTE: (1) p<sub>CLK</sub> will be equal to t<sub>CLK</sub>, except that p<sub>CLK</sub> will stop for IDLE. (2) For modes 1 and 3, the selection of Timer 1 or 2 for baud rate is specified via the T2CON (C8<sub>H</sub>) register.

**REN\_0** Receive Enable. This bit enables/disables the serial Port 0 received shift register.  
 bit 4 0: Serial Port 0 reception disabled.  
 1: Serial Port 0 received enabled (modes 1, 2, and 3). Initiate synchronous reception (mode 0).

**TB8\_0** 9th Transmission Bit State. This bit defines the state of the 9th transmission bit in serial Port 0 modes 2 and 3.  
 bit 3

**RB8\_0** 9th Received Bit State. This bit identifies the state of the 9th reception bit of received data in serial Port 0 modes 2 and 3. In serial port mode 1, when SM2\_0 = 0, RB8\_0 is the state of the stop bit. RB8\_0 is not used in mode 0.  
 bit 2

**TI\_0** Transmitter Interrupt Flag. This bit indicates that data in the serial Port 0 buffer has been completely shifted out. In serial port mode 0, TI\_0 is set at the end of the 8th data bit. In all other modes, this bit is set at the end of the last data bit. This bit must be manually cleared by software.  
 bit 1

**RI\_0** **Receiver Interrupt Flag.** This bit indicates that a byte of data has been received in the serial Port 0 buffer. In serial port mode 0, RI\_0 is set at the end of the 8th bit. In serial port mode 1, RI\_0 is set after the last sample of the incoming stop bit subject to the state of SM2\_0. In modes 2 and 3, RI\_0 is set after the last sample of RB8\_0. This bit must be manually cleared by software.

### Serial Data Buffer 0 (SBUF0)

|                     |   |   |   |   |   |   |   |   |                 |
|---------------------|---|---|---|---|---|---|---|---|-----------------|
|                     | 7 | 6 | 5 | 4 | 3 | 2 | 1 | 0 | Reset Value     |
| SFR 99 <sub>H</sub> |   |   |   |   |   |   |   |   | 00 <sub>H</sub> |

**SBUF0** **Serial Data Buffer 0.** Data for Serial Port 0 is read from or written to this location. The serial transmit and receive buffers are separate registers, but both are addressed at this location.

**SPI Control (SPICON).** Any change resets the SPI interface, counters, and pointers. PDCON controls which is enabled.

|                     |       |       |       |      |       |      |      |      |                 |
|---------------------|-------|-------|-------|------|-------|------|------|------|-----------------|
|                     | 7     | 6     | 5     | 4    | 3     | 2    | 1    | 0    | Reset Value     |
| SFR 9A <sub>H</sub> | SCLK2 | SCLK1 | SCLK0 | FIFO | ORDER | MSTR | CPHA | CPOL | 00 <sub>H</sub> |

**SCLK** **SCK Selection.** Selection of  $t_{CLK}$  divider for generation of SCK in Master mode.  
bits 7-5

| SCLK2 | SCLK1 | SCLK0 | SCK PERIOD    |
|-------|-------|-------|---------------|
| 0     | 0     | 0     | $t_{CLK}/2$   |
| 0     | 0     | 1     | $t_{CLK}/4$   |
| 0     | 1     | 0     | $t_{CLK}/8$   |
| 0     | 1     | 1     | $t_{CLK}/16$  |
| 1     | 0     | 0     | $t_{CLK}/32$  |
| 1     | 0     | 1     | $t_{CLK}/64$  |
| 1     | 1     | 0     | $t_{CLK}/128$ |
| 1     | 1     | 1     | $t_{CLK}/256$ |

**FIFO** **Enable FIFO in on-chip indirect memory.**  
bit 4  
0: Both transmit and receive are double buffers  
1: Circular FIFO used for transmit and receive bytes

**ORDER** **Set Bit Order for Transmit and Receive.**  
bit 3  
0: Most Significant Bits First  
1: Least Significant Bits First

**MSTR** **SPI Master Mode.**  
bit 2  
0: Slave Mode  
1: Master Mode

**CPHA** **Serial Clock Phase Control.**  
bit 1  
0: Valid data starting from half SCK period before the first edge of SCK  
1: Valid data starting from the first edge of SCK

**CPOL** **Serial Clock Polarity.**  
bit 0  
0: SCK idle at logic LOW  
1: SCK idle at logic HIGH

### SPI Data Register (SPIDATA)

|                     |   |   |   |   |   |   |   |   |                 |
|---------------------|---|---|---|---|---|---|---|---|-----------------|
|                     | 7 | 6 | 5 | 4 | 3 | 2 | 1 | 0 | Reset Value     |
| SFR 9B <sub>H</sub> |   |   |   |   |   |   |   |   | 00 <sub>H</sub> |

**SPIDATA** **SPI Data Register.** Data for SPI is read from or written to this location. The SPI transmit and receive buffers are separate registers, but both are addressed at this location.

## SPI Receive Control Register (SPIRCON)

|                     | 7                 | 6      | 5      | 4      | 3      | 2                | 1                | 0                | Reset Value     |
|---------------------|-------------------|--------|--------|--------|--------|------------------|------------------|------------------|-----------------|
| SFR 9C <sub>H</sub> | RXCNT7<br>RXFLUSH | RXCNT6 | RXCNT5 | RXCNT4 | RXCNT3 | RXCNT2<br>RXIRQ2 | RXCNT1<br>RXIRQ1 | RXCNT0<br>RXIRQ0 | 00 <sub>H</sub> |

**RXCNT** **Receive Counter.** Read only bits which read the number of bytes in the receive buffer (0 to 128).  
bits 7-0

**RXFLUSH** **Flush Receive FIFO.** Write only.  
bit 7  
0: No Action  
1: SPI Receive Buffer Set to Empty

**RXIRQ** **Read IRQ Level.** Write only.  
bits 2-0

|     |  |
|-----|--|
| 000 | Generate IRQ when Receive Count = 1 or more.   |
| 001 | Generate IRQ when Receive Count = 2 or more.   |
| 010 | Generate IRQ when Receive Count = 4 or more.   |
| 011 | Generate IRQ when Receive Count = 8 or more.   |
| 100 | Generate IRQ when Receive Count = 16 or more.  |
| 101 | Generate IRQ when Receive Count = 32 or more.  |
| 110 | Generate IRQ when Receive Count = 64 or more.  |
| 111 | Generate IRQ when Receive Count = 128 or more. |

## SPI Transmit Control Register (SPITCON)

|                     | 7                 | 6      | 5                | 4                 | 3                | 2                | 1                | 0                | Reset Value     |
|---------------------|-------------------|--------|------------------|-------------------|------------------|------------------|------------------|------------------|-----------------|
| SFR 9D <sub>H</sub> | TXCNT7<br>TXFLUSH | TXCNT6 | TXCNT5<br>CLK_EN | TXCNT4<br>DRV_DLY | TXCNT3<br>DRV_EN | TXCNT2<br>TXIRQ2 | TXCNT1<br>TXIRQ1 | TXCNT0<br>TXIRQ0 | 00 <sub>H</sub> |

**TXCNT** **Transmit Counter.** Read only bits which read the number of bytes in the transmit buffer (0 to 128).  
bits 7-0

**TXFLUSH** **Flush Transmit FIFO.** This bit is write only. When set, the SPI transmit pointer is set equal to the FIFO Output pointer. This bit is 0 for a read operation.  
bit 7

**CLK\_EN** **SCLK Driver Enable.**  
bit 5  
0: Disable SCLK Driver (Master Mode)  
1: Enable SCLK Driver (Master Mode)

**DRV\_DLY** **Drive Delay (refer to DRV\_EN bit).**  
bit 4  
0: Drive Output Immediately  
1: Drive Output After Current Byte Transfer

**DRV\_EN** **Drive Enable.**  
bit 3

| DRV_DLY | DRV_EN | MOSI or MISO OUTPUT CONTROL              |
|---------|--------|--|
| 0       | 0      | Tristate Immediately                     |
| 0       | 1      | Drive Immediately                        |
| 1       | 0      | Tristate After the Current Byte Transfer |
| 1       | 1      | Drive After the Current Byte Transfer    |

**TXIRQ** **Transmit IRQ Level.** Write only bits.  
bits 2-0

|     |   |
|-----|---|
| 000 | Generate IRQ when Transmit count = 1 or less.   |
| 001 | Generate IRQ when Transmit count = 2 or less.   |
| 010 | Generate IRQ when Transmit count = 4 or less.   |
| 011 | Generate IRQ when Transmit count = 8 or less.   |
| 100 | Generate IRQ when Transmit count = 16 or less.  |
| 101 | Generate IRQ when Transmit count = 32 or less.  |
| 110 | Generate IRQ when Transmit count = 64 or less.  |
| 111 | Generate IRQ when Transmit count = 128 or less. |

### SPI Buffer Start Address (SPISTART)

|                     | 7 | 6 | 5 | 4 | 3 | 2 | 1 | 0 | Reset Value     |
|---------------------|---|---|---|---|---|---|---|---|-----------------|
| SFR 9E <sub>H</sub> | 1 |   |   |   |   |   |   |   | 80 <sub>H</sub> |

**SPISTART** **SPI FIFO Start Address.** Write only. This specifies the start address of the SPI data buffer. This is a circular FIFO that is located in the 128 bytes of indirect RAM. The FIFO starts at this address and ends at the address specified in SPIEND. Must be less than SPIEND. Writing clears SPI transmit and receive counters.  
bits 6-0

**SPI TP** **SPI Transmit Pointer.** Read Only. This is the FIFO address for SPI transmissions. This is where the next byte will be written into the SPI FIFO buffer. This pointer increments after each write to the SPI Data register unless that would make it equal to the SPI Receive pointer.  
bits 6-0

### SPI Buffer End Address (SPIEND)

|                     | 7 | 6 | 5 | 4 | 3 | 2 | 1 | 0 | Reset Value     |
|---------------------|---|---|---|---|---|---|---|---|-----------------|
| SFR 9F <sub>H</sub> | 1 |   |   |   |   |   |   |   | 80 <sub>H</sub> |

**SPIEND** **SPI FIFO End Address.** Write only. This specifies the end address of the SPI data FIFO. This is a circular buffer that is located in the 128 bytes of indirect RAM. The buffer starts at SPISTART and ends at this address.  
bits 6-0

**SPI RP** **SPI Receive Pointer.** Read Only. This is the FIFO address for SPI received bytes. This is the location of the next byte to be read from the SPI FIFO. This increments with each read from the SPI Data register until the RxCNT is zero.  
bits 6-0

### Port 2 (P2)

|                     | 7 | 6 | 5 | 4 | 3 | 2 | 1 | 0 | Reset Value     |
|---------------------|---|---|---|---|---|---|---|---|-----------------|
| SFR A0 <sub>H</sub> |   |   |   |   |   |   |   |   | FF <sub>H</sub> |

**P2** **Port 2.** This port functions as an address bus during external memory access, and as a general-purpose I/O port. During external memory cycles, this port will contain the MSB of the address. Whether Port 2 is used as general-purpose I/O or for external memory access is determined by the Flash Configuration Register (HCR1.0).  
bits 7-0

### PWM Control (PWMCON)

|                     | 7 | 6 | 5    | 4      | 3      | 2        | 1        | 0        | Reset Value     |
|---------------------|---|---|------|--------|--------|----------|----------|----------|-----------------|
| SFR A1 <sub>H</sub> | — | — | PPOL | PWMSEL | SPDSEL | TPCNTL.2 | TPCNTL.1 | TPCNTL.0 | 00 <sub>H</sub> |

**PPOL** **Period Polarity.** Specifies the starting level of the PWM pulse.  
bit 5  
0: ON Period. PWM Duty register programs the ON period.  
1: OFF Period. PWM Duty register programs the OFF period.

**PWMSEL** **PWM Register Select.** Select which 16-bit register is accessed by PWMLOW/PWMHIGH.  
bit 4  
0: Period (must be 0 for TONE mode)  
1: Duty

**SPDSEL** **Speed Select.**  
bit 3  
0: 1MHz (the USEC Clock)  
1: SYSCLK

**TPCNTL** **Tone Generator/Pulse Width Modulation Control.**

| bits 2-0 | TPCNTL.2 | TPCNTL.1 | TPCNTL.0 | MODE              |
|----------|----------|----------|----------|-------------------|
|          | 0        | 0        | 0        | Disable (default) |
|          | 0        | 0        | 1        | PWM               |
|          | 0        | 1        | 1        | TONE—Square       |
|          | 1        | 1        | 1        | TONE—Staircase    |

### Tone Low (TONELOW) /PWM Low (PWMLOW)

|                     | 7             | 6             | 5             | 4             | 3             | 2             | 1             | 0             | Reset Value     |
|---------------------|---------------|---------------|---------------|---------------|---------------|---------------|---------------|---------------|-----------------|
| SFR A2 <sub>H</sub> | PWM7<br>TDIV7 | PWM6<br>TDIV6 | PWM5<br>TDIV5 | PWM4<br>TDIV4 | PWM3<br>TDIV3 | PWM2<br>TDIV2 | PWM1<br>TDIV1 | PWM0<br>TDIV0 | 00 <sub>H</sub> |

**PWMLOW** **Pulse Width Modulator Low Bits.** These 8 bits are the least significant 8 bits of the PWM register.  
bits 7-0

**TDIV7-0** **Tone Divisor.** The low order bits that define the half-time period. For staircase mode the output is high impedance for the last 1/4 of this period.  
bits 7-0

## Tone High (TONEHI)/PWM High (PWMHI)

|                     | 7               | 6               | 5               | 4               | 3               | 2               | 1             | 0             | Reset Value     |
|---------------------|-----------------|-----------------|-----------------|-----------------|-----------------|-----------------|---------------|---------------|-----------------|
| SFR A3 <sub>H</sub> | PWM15<br>TDIV15 | PWM14<br>TDIV14 | PWM13<br>TDIV13 | PWM12<br>TDIV12 | PWM11<br>TDIV11 | PWM10<br>TDIV10 | PWM9<br>TDIV9 | PWM8<br>TDIV8 | 00 <sub>H</sub> |

**PWMHI** **Pulse Width Modulator High Bits.** These 8 bits are the high order bits of the PWM register.  
bits 7-0

**TDIV15-8** **Tone Divisor.** The high order bits that define the half time period. For staircase mode the output is high impedance for the last 1/4 of this period.  
bits 7-0

## Pending Auxiliary Interrupt (PAI)

|                     | 7 | 6 | 5 | 4 | 3    | 2    | 1    | 0    | Reset Value     |
|---------------------|---|---|---|---|------|------|------|------|-----------------|
| SFR A5 <sub>H</sub> | 0 | 0 | 0 | 0 | PAI3 | PAI2 | PAI1 | PAI0 | 00 <sub>H</sub> |

**PAI** **Pending Auxiliary Interrupt Register.** The results of this register can be used as an index to vector to the appropriate interrupt routine. All of these interrupts vector through address 0033<sub>H</sub>.  
bits 3-0

| PAI3 | PAI2 | PAI1 | PAI0 | AUXILIARY INTERRUPT STATUS               |
|------|------|------|------|--|
| 0    | 0    | 0    | 0    | No Pending Auxiliary IRQ                 |
| 0    | 0    | 0    | 1    | Digital Low Voltage IRQ Pending          |
| 0    | 0    | 1    | 0    | Analog Low Voltage IRQ Pending           |
| 0    | 0    | 1    | 1    | SPI Receive IRQ Pending                  |
| 0    | 1    | 0    | 0    | SPI Transmit IRQ Pending                 |
| 0    | 1    | 0    | 1    | One Millisecond System Timer IRQ Pending |
| 0    | 1    | 1    | 0    | Analog to Digital Conversion IRQ Pending |
| 0    | 1    | 1    | 1    | Accumulator IRQ Pending                  |
| 1    | 0    | 0    | 0    | One Second System Timer IRQ Pending      |

## Auxiliary Interrupt Enable (AIE)

|                     | 7    | 6    | 5    | 4     | 3     | 2     | 1    | 0     | Reset Value     |
|---------------------|------|------|------|-------|-------|-------|------|-------|-----------------|
| SFR A6 <sub>H</sub> | ESEC | ESUM | EADC | EMSEC | ESPIT | ESPIR | EALV | EDLVB | 00 <sub>H</sub> |

Interrupts are enabled by EICON.4 (SFR D8<sub>H</sub>). The other interrupts are controlled by the IE and EIE registers.

**ESEC** **Enable Seconds Timer Interrupt (lowest priority auxiliary interrupt).**  
bit 7  
Write: Set mask bit for this interrupt 0 = masked, 1 = enabled.  
Read: Current value of **Seconds Timer Interrupt** before masking.

**ESUM** **Enable Summation Interrupt.**  
bit 6  
Write: Set mask bit for this interrupt 0 = masked, 1 = enabled.  
Read: Current value of **Summation Interrupt** before masking.

**EADC** **Enable ADC Interrupt.**  
bit 5  
Write: Set mask bit for this interrupt 0 = masked, 1 = enabled.  
Read: Current value of **ADC Interrupt** before masking.

**EMSEC** **Enable Millisecond System Timer Interrupt.**  
bit 4  
Write: Set mask bit for this interrupt 0 = masked, 1 = enabled.  
Read: Current value of **Millisecond System Timer Interrupt** before masking.

**ESPIT** **Enable SPI Transmit Interrupt.**  
bit 3  
Write: Set mask bit for this interrupt 0 = masked, 1 = enabled.  
Read: Current value of **SPI Transmit Interrupt** before masking.

**ESPIR** **Enable SPI Receive Interrupt.**  
bit 2  
Write: Set mask bit for this interrupt 0 = masked, 1 = enabled.  
Read: Current value of **SPI Receive Interrupt** before masking.

**EALV** **Enable Analog Low Voltage Interrupt.**  
bit 1  
Write: Set mask bit for this interrupt 0 = masked, 1 = enabled.  
Read: Current value of **Analog Low Voltage Interrupt** before masking.

**EDLVB** **Enable Digital Low Voltage or Breakpoint Interrupt (highest priority auxiliary interrupt).**  
bit 0  
Write: Set mask bit for this interrupt 0 = masked, 1 = enabled.  
Read: Current value of **Digital Low Voltage or Breakpoint Interrupt** before masking.

## Auxiliary Interrupt Status Register (AISTAT)

|                     | 7   | 6   | 5   | 4    | 3    | 2    | 1    | 0    | Reset Value     |
|---------------------|-----|-----|-----|------|------|------|------|------|-----------------|
| SFR A7 <sub>H</sub> | SEC | SUM | ADC | MSEC | SPIT | SPIR | ALVD | DLVD | 00 <sub>H</sub> |

### SEC Second System Timer Interrupt Status Flag (lowest priority AI).

bit 7  
0: SEC interrupt inactive or masked.  
1: SEC Interrupt active.

### SUM Summation Register Interrupt Status Flag.

bit 6  
0: SUM interrupt inactive or masked (if active, it is set inactive by reading the lowest byte of the Summation register).  
1: SUM interrupt active.

### ADC ADC Interrupt Status Flag.

bit 5  
0: ADC interrupt inactive or masked (If active, it is set inactive by reading the lowest byte of the Data Output Register).  
1: ADC interrupt active (If active no new data will be written to the Data Output Register).

### MSEC Millisecond System Timer Interrupt Status Flag.

bit 4  
0: MSEC interrupt inactive or masked.  
1: MSEC interrupt active.

### SPIT SPI Transmit Interrupt Status Flag.

bit 3  
0: SPI transmit interrupt inactive or masked.  
1: SPI transmit interrupt active.

### SPIR SPI Receive Interrupt Status Flag.

bit 2  
0: SPI receive interrupt inactive or masked.  
1: SPI receive interrupt active.

### ALVD Analog Low Voltage Detect Interrupt Status Flag.

bit 1  
0: ALVD interrupt inactive or masked.  
1: ALVD interrupt active.

### DLVD Digital Low Voltage Detect or Breakpoint Interrupt Status Flag (highest priority AI).

bit 0  
0: DLVD interrupt inactive or masked.  
1: DLVD interrupt active.

## Interrupt Enable (IE)

|                     | 7  | 6   | 5   | 4   | 3   | 2   | 1   | 0   | Reset Value     |
|---------------------|----|-----|-----|-----|-----|-----|-----|-----|-----------------|
| SFR A8 <sub>H</sub> | EA | ES1 | ET2 | ES0 | ET1 | EX1 | ET0 | EX0 | 00 <sub>H</sub> |

**EA Global Interrupt Enable.** This bit controls the global masking of all interrupts except those in AIE (SFR A6<sub>H</sub>).  
bit 7  
0: Disable interrupt sources. This bit overrides individual interrupt mask settings for this register.  
1: Enable all individual interrupt masks. Individual interrupts in this register will occur if enabled.

**ES1 Enable Serial Port 1 Interrupt.** This bit controls the masking of the serial Port 1 interrupt.  
bit 6  
0: Disable all serial Port 1 interrupts.  
1: Enable interrupt requests generated by the RI\_1 (SCON1.0, SFR C0<sub>H</sub>) or TI\_1 (SCON1.1, SFR C0<sub>H</sub>) flags.

**ET2 Enable Timer 2 Interrupt.** This bit controls the masking of the Timer 2 interrupt.  
bit 5  
0: Disable all Timer 2 interrupts.  
1: Enable interrupt requests generated by the TF2 flag (T2CON.7, SFR C8<sub>H</sub>).

**ES0 Enable Serial port 0 interrupt.** This bit controls the masking of the serial Port 0 interrupt.  
bit 4  
0: Disable all serial Port 0 interrupts.  
1: Enable interrupt requests generated by the RI\_0 (SCON0.0, SFR 98<sub>H</sub>) or TI\_0 (SCON0.1, SFR 98<sub>H</sub>) flags.

- ET1** **Enable Timer 1 Interrupt.** This bit controls the masking of the Timer 1 interrupt.  
bit 3  
0: Disable Timer 1 interrupt.  
1: Enable interrupt requests generated by the TF1 flag (TCON.7, SFR 88<sub>H</sub>).
- EX1** **Enable External Interrupt 1.** This bit controls the masking of external interrupt 1.  
bit 2  
0: Disable external interrupt 1.  
1: Enable interrupt requests generated by the  $\overline{\text{INT1}}$  pin.
- ET0** **Enable Timer 0 Interrupt.** This bit controls the masking of the Timer 0 interrupt.  
bit 1  
0: Disable all Timer 0 interrupts.  
1: Enable interrupt requests generated by the TF0 flag (TCON.5, SFR 88<sub>H</sub>).
- EX0** **Enable External Interrupt 0.** This bit controls the masking of external interrupt 0.  
bit 0  
0: Disable external interrupt 0.  
1: Enable interrupt requests generated by the  $\overline{\text{INT0}}$  pin.

### Breakpoint Control (BPCON)

|                     | 7  | 6 | 5 | 4 | 3 | 2 | 1     | 0   | Reset Value     |
|---------------------|----|---|---|---|---|---|-------|-----|-----------------|
| SFR A9 <sub>H</sub> | BP | 0 | 0 | 0 | 0 | 0 | PMSEL | EBP | 00 <sub>H</sub> |

Writing to register sets the breakpoint condition specified by MCON, BPL, and BPH.

- BP** **Breakpoint Interrupt.** This bit indicates that a break condition has been recognized by a hardware breakpoint register(s).  
bit 7  
Read: Status of Breakpoint Interrupt. Will indicate a breakpoint match for any of the breakpoint registers.  
Write: 0: No effect.  
1: Clear Breakpoint 1 for breakpoint register selected by MCON (SFR 95<sub>H</sub>).
- PMSEL** **Program Memory Select.** Write this bit to select memory for address breakpoints of register selected in MCON (SFR 95<sub>H</sub>).  
bit 1  
0: Break on address in data memory.  
1: Break on address in program memory.
- EBP** **Enable Breakpoint.** This bit enables this breakpoint register. Address of breakpoint register selected by MCON (SFR 95<sub>H</sub>).  
bit 0  
0: Breakpoint disabled.  
1: Breakpoint enabled.

### Breakpoint Low (BPL) Address for BP Register Selected in MCON (95<sub>H</sub>)

|                     | 7     | 6     | 5     | 4     | 3     | 2     | 1     | 0     | Reset Value     |
|---------------------|-------|-------|-------|-------|-------|-------|-------|-------|-----------------|
| SFR AA <sub>H</sub> | BPL.7 | BPL.6 | BPL.5 | BPL.4 | BPL.3 | BPL.2 | BPL.1 | BPL.0 | 00 <sub>H</sub> |

**BPL.7-0** **Breakpoint Low Address.** The low 8 bits of the 16 bit breakpoint address.  
bits 7-0

### Breakpoint High Address (BPH) Address for BP Register Selected in MCON (95<sub>H</sub>)

|                     | 7     | 6     | 5     | 4     | 3     | 2     | 1     | 0     | Reset Value     |
|---------------------|-------|-------|-------|-------|-------|-------|-------|-------|-----------------|
| SFR AB <sub>H</sub> | BPH.7 | BPH.6 | BPH.5 | BPH.4 | BPH.3 | BPH.2 | BPH.1 | BPH.0 | 00 <sub>H</sub> |

**BPH.7-0** **Breakpoint High Address.** The high 8 bits of the 16 bit breakpoint address.  
bits 7-0

## Port 0 Data Direction Low Register (P0DDRL)

|                     | 7    | 6    | 5    | 4    | 3    | 2    | 1    | 0    | Reset Value     |
|---------------------|------|------|------|------|------|------|------|------|-----------------|
| SFR AC <sub>H</sub> | P03H | P03L | P02H | P02L | P01H | P01L | P00H | P00L | 00 <sub>H</sub> |

### P0.3 Port 0 bit 3 control.

bits 7-6

| P03H | P03L |                        |
|------|------|------------------------|
| 0    | 0    | Standard 8051(Pull-Up) |
| 0    | 1    | CMOS Output            |
| 1    | 0    | Open Drain Output      |
| 1    | 1    | Input                  |

### P0.2 Port 0 bit 2 control.

bits 5-4

| P02H | P02L |                        |
|------|------|------------------------|
| 0    | 0    | Standard 8051(Pull-Up) |
| 0    | 1    | CMOS Output            |
| 1    | 0    | Open Drain Output      |
| 1    | 1    | Input                  |

### P0.1 Port 0 bit 1 control.

bits 3-2

| P01H | P01L |                        |
|------|------|------------------------|
| 0    | 0    | Standard 8051(Pull-Up) |
| 0    | 1    | CMOS Output            |
| 1    | 0    | Open Drain Output      |
| 1    | 1    | Input                  |

### P0.0 Port 0 bit 0 control.

bits 1-0

| P00H | P00L |                        |
|------|------|------------------------|
| 0    | 0    | Standard 8051(Pull-Up) |
| 0    | 1    | CMOS Output            |
| 1    | 0    | Open Drain Output      |
| 1    | 1    | Input                  |

NOTE: Port 0 also controlled by  $\overline{EA}$  and Memory Access Control HCR1.1.

## Port 0 Data Direction High Register (P0DDRH)

|                     | 7    | 6    | 5    | 4    | 3    | 2    | 1    | 0    | Reset Value     |
|---------------------|------|------|------|------|------|------|------|------|-----------------|
| SFR AD <sub>H</sub> | P07H | P07L | P06H | P06L | P05H | P05L | P04H | P04L | 00 <sub>H</sub> |

### P0.7 Port 0 bit 7 control.

bits 7-6

| P07H | P07L |                        |
|------|------|------------------------|
| 0    | 0    | Standard 8051(Pull-Up) |
| 0    | 1    | CMOS Output            |
| 1    | 0    | Open Drain Output      |
| 1    | 1    | Input                  |

### P0.6 Port 0 bit 6 control.

bits 5-4

| P06H | P06L |                        |
|------|------|------------------------|
| 0    | 0    | Standard 8051(Pull-Up) |
| 0    | 1    | CMOS Output            |
| 1    | 0    | Open Drain Output      |
| 1    | 1    | Input                  |

### P0.5 Port 0 bit 5 control.

bits 3-2

| P05H | P05L |                        |
|------|------|------------------------|
| 0    | 0    | Standard 8051(Pull-Up) |
| 0    | 1    | CMOS Output            |
| 1    | 0    | Open Drain Output      |
| 1    | 1    | Input                  |

### P0.4 Port 0 bit 4 control.

bits 1-0

| P04H | P04L |                        |
|------|------|------------------------|
| 0    | 0    | Standard 8051(Pull-Up) |
| 0    | 1    | CMOS Output            |
| 1    | 0    | Open Drain Output      |
| 1    | 1    | Input                  |

NOTE: Port 0 also controlled by  $\overline{EA}$  and Memory Access Control HCR1.1.

## Port 1 Data Direction Low Register (P1DDRL)

|                     | 7    | 6    | 5    | 4    | 3    | 2    | 1    | 0    | Reset Value     |
|---------------------|------|------|------|------|------|------|------|------|-----------------|
| SFR AE <sub>H</sub> | P13H | P13L | P12H | P12L | P11H | P11L | P10H | P10L | 00 <sub>H</sub> |

### P1.3 Port 1 bit 3 control.

bits 7-6

| P13H | P13L |                   |
|------|------|-------------------|
| 0    | 0    | Standard 8051     |
| 0    | 1    | CMOS Output       |
| 1    | 0    | Open Drain Output |
| 1    | 1    | Input             |

### P1.2 Port 1 bit 2 control.

bits 5-4

| P12H | P12L |                   |
|------|------|-------------------|
| 0    | 0    | Standard 8051     |
| 0    | 1    | CMOS Output       |
| 1    | 0    | Open Drain Output |
| 1    | 1    | Input             |

### P1.1 Port 1 bit 1 control.

bits 3-2

| P11H | P11L |                   |
|------|------|-------------------|
| 0    | 0    | Standard 8051     |
| 0    | 1    | CMOS Output       |
| 1    | 0    | Open Drain Output |
| 1    | 1    | Input             |

### P1.0 Port 1 bit 0 control.

bits 1-0

| P10H | P10L |                   |
|------|------|-------------------|
| 0    | 0    | Standard 8051     |
| 0    | 1    | CMOS Output       |
| 1    | 0    | Open Drain Output |
| 1    | 1    | Input             |

## Port 1 Data Direction High Register (P1DDRH)

|                     | 7    | 6    | 5    | 4    | 3    | 2    | 1    | 0    | Reset Value     |
|---------------------|------|------|------|------|------|------|------|------|-----------------|
| SFR AF <sub>H</sub> | P17H | P17L | P16H | P16L | P15H | P15L | P14H | P14L | 00 <sub>H</sub> |

### P1.7 Port 1 bit 7 control.

bits 7-6

| P17H | P17L |                   |
|------|------|-------------------|
| 0    | 0    | Standard 8051     |
| 0    | 1    | CMOS Output       |
| 1    | 0    | Open Drain Output |
| 1    | 1    | Input             |

### P1.6 Port 1 bit 6 control.

bits 5-4

| P16H | P16L |                   |
|------|------|-------------------|
| 0    | 0    | Standard 8051     |
| 0    | 1    | CMOS Output       |
| 1    | 0    | Open Drain Output |
| 1    | 1    | Input             |

### P1.5 Port 1 bit 5 control.

bits 3-2

| P15H | P15L |                   |
|------|------|-------------------|
| 0    | 0    | Standard 8051     |
| 0    | 1    | CMOS Output       |
| 1    | 0    | Open Drain Output |
| 1    | 1    | Input             |

### P1.4 Port 1 bit 4 control.

bits 1-0

| P14H | P14L |                   |
|------|------|-------------------|
| 0    | 0    | Standard 8051     |
| 0    | 1    | CMOS Output       |
| 1    | 0    | Open Drain Output |
| 1    | 1    | Input             |

## Port 3 (P3)

|                     | 7                       | 6                       | 5          | 4          | 3                         | 2                         | 1            | 0            | Reset Value     |
|---------------------|-------------------------|-------------------------|------------|------------|---------------------------|---------------------------|--------------|--------------|-----------------|
| SFR B0 <sub>H</sub> | P3.7<br>$\overline{RD}$ | P3.6<br>$\overline{WR}$ | P3.5<br>T1 | P3.4<br>T0 | P3.3<br>$\overline{INT1}$ | P3.2<br>$\overline{INT0}$ | P3.1<br>TXD0 | P3.0<br>RXD0 | FF <sub>H</sub> |

**P3.7-0** bits 7-0 **General-Purpose I/O Port 3.** This register functions as a general-purpose I/O port. In addition, all the pins have an alternative function listed below. Each of the functions is controlled by several other SFRs. The associated Port 3 latch bit must contain a logic '1' before the pin can be used in its alternate function capacity.

**$\overline{RD}$**  bit 7 **External Data Memory Read Strobe.** This pin provides an active low read strobe to an external memory device. If Port 0 or Port 2 is selected for external memory in the HCR1 register, this function will be enabled even if a 1 is not written to this latch bit. When external memory is selected, the settings of P3DRRH are ignored.

**$\overline{WR}$**  bit 6 **External Data Memory Write Strobe.** This pin provides an active low write strobe to an external memory device. If Port 0 or Port 2 is selected for external memory in the HCR1 register, this function will be enabled even if a 1 is not written to this latch bit. When external memory is selected, the settings of P3DRRH are ignored.

**T1** bit 5 **Timer/Counter 1 External Input.** A 1 to 0 transition on this pin will increment Timer 1.

**T0** bit 4 **Timer/Counter 0 External Input.** A 1 to 0 transition on this pin will increment Timer 0.

**$\overline{INT1}$**  bit 3 **External Interrupt 1.** A falling edge/low level on this pin will cause an external interrupt 1 if enabled.

**$\overline{INT0}$**  bit 2 **External Interrupt 0.** A falling edge/low level on this pin will cause an external interrupt 0 if enabled.

**TXD0** bit 1 **Serial Port 0 Transmit.** This pin transmits the serial Port 0 data in serial port modes 1, 2, 3, and emits the synchronizing clock in serial port mode 0.

**RXD0** bit 0 **Serial Port 0 Receive.** This pin receives the serial Port 0 data in serial port modes 1, 2, 3, and is a bidirectional data transfer pin in serial port mode 0.

## Port 2 Data Direction Low Register (P2DDRL)

|                     | 7    | 6    | 5    | 4    | 3    | 2    | 1    | 0    | Reset Value     |
|---------------------|------|------|------|------|------|------|------|------|-----------------|
| SFR B1 <sub>H</sub> | P23H | P23L | P22H | P22L | P21H | P21L | P20H | P20L | 00 <sub>H</sub> |

**P2.3** bits 7-6 **Port 2 bit 3 control.**

| P23H | P23L |                   |
|------|------|-------------------|
| 0    | 0    | Standard 8051     |
| 0    | 1    | CMOS Output       |
| 1    | 0    | Open Drain Output |
| 1    | 1    | Input             |

**P2.2** bits 5-4 **Port 2 bit 2 control.**

| P22H | P22L |                   |
|------|------|-------------------|
| 0    | 0    | Standard 8051     |
| 0    | 1    | CMOS Output       |
| 1    | 0    | Open Drain Output |
| 1    | 1    | Input             |

**P2.1** bits 3-2 **Port 2 bit 1 control.**

| P21H | P21L |                   |
|------|------|-------------------|
| 0    | 0    | Standard 8051     |
| 0    | 1    | CMOS Output       |
| 1    | 0    | Open Drain Output |
| 1    | 1    | Input             |

**P2.0** bits 1-0 **Port 2 bit 0 control.**

| P20H | P20L |                   |
|------|------|-------------------|
| 0    | 0    | Standard 8051     |
| 0    | 1    | CMOS Output       |
| 1    | 0    | Open Drain Output |
| 1    | 1    | Input             |

NOTE: Port 2 also controlled by  $\overline{EA}$  and Memory Access Control HCR1.1.

## Port 2 Data Direction High Register (P2DDRH)

|                     | 7    | 6    | 5    | 4    | 3    | 2    | 1    | 0    | Reset Value     |
|---------------------|------|------|------|------|------|------|------|------|-----------------|
| SFR B2 <sub>H</sub> | P27H | P27L | P26H | P26L | P25H | P25L | P24H | P24L | 00 <sub>H</sub> |

### P2.7 Port 2 bit 7 control.

bits 7-6

| P27H | P27L |                   |
|------|------|-------------------|
| 0    | 0    | Standard 8051     |
| 0    | 1    | CMOS Output       |
| 1    | 0    | Open Drain Output |
| 1    | 1    | Input             |

### P2.6 Port 2 bit 6 control.

bits 5-4

| P26H | P26L |                   |
|------|------|-------------------|
| 0    | 0    | Standard 8051     |
| 0    | 1    | CMOS Output       |
| 1    | 0    | Open Drain Output |
| 1    | 1    | Input             |

### P2.5 Port 2 bit 5 control.

bits 3-2

| P25H | P25L |                   |
|------|------|-------------------|
| 0    | 0    | Standard 8051     |
| 0    | 1    | CMOS Output       |
| 1    | 0    | Open Drain Output |
| 1    | 1    | Input             |

### P2.4 Port 2 bit 4 control.

bits 1-0

| P24H | P24L |                   |
|------|------|-------------------|
| 0    | 0    | Standard 8051     |
| 0    | 1    | CMOS Output       |
| 1    | 0    | Open Drain Output |
| 1    | 1    | Input             |

NOTE: Port 2 also controlled by  $\overline{EA}$  and Memory Access Control HCR1.1.

## Port 3 Data Direction Low Register (P3DDRL)

|                     | 7    | 6    | 5    | 4    | 3    | 2    | 1    | 0    | Reset Value     |
|---------------------|------|------|------|------|------|------|------|------|-----------------|
| SFR B3 <sub>H</sub> | P33H | P33L | P32H | P32L | P31H | P31L | P30H | P30L | 00 <sub>H</sub> |

### P3.3 Port 3 bit 3 control.

bits 7-6

| P33H | P33L |                   |
|------|------|-------------------|
| 0    | 0    | Standard 8051     |
| 0    | 1    | CMOS Output       |
| 1    | 0    | Open Drain Output |
| 1    | 1    | Input             |

### P3.2 Port 3 bit 2 control.

bits 5-4

| P32H | P32L |                   |
|------|------|-------------------|
| 0    | 0    | Standard 8051     |
| 0    | 1    | CMOS Output       |
| 1    | 0    | Open Drain Output |
| 1    | 1    | Input             |

### P3.1 Port 3 bit 1 control.

bits 3-2

| P31H | P31L |                   |
|------|------|-------------------|
| 0    | 0    | Standard 8051     |
| 0    | 1    | CMOS Output       |
| 1    | 0    | Open Drain Output |
| 1    | 1    | Input             |

### P3.0 Port 3 bit 0 control.

bits 1-0

| P30H | P30L |                   |
|------|------|-------------------|
| 0    | 0    | Standard 8051     |
| 0    | 1    | CMOS Output       |
| 1    | 0    | Open Drain Output |
| 1    | 1    | Input             |

## Port 3 Data Direction High Register (P3DDRH)

|                     | 7    | 6    | 5    | 4    | 3    | 2    | 1    | 0    | Reset Value     |
|---------------------|------|------|------|------|------|------|------|------|-----------------|
| SFR B4 <sub>H</sub> | P37H | P37L | P36H | P36L | P35H | P35L | P34H | P34L | 00 <sub>H</sub> |

### P3.7 Port 3 bit 7 control.

bits 7-6

| P37H | P37L |                   |
|------|------|-------------------|
| 0    | 0    | Standard 8051     |
| 0    | 1    | CMOS Output       |
| 1    | 0    | Open Drain Output |
| 1    | 1    | Input             |

NOTE: Port 3.7 also controlled by  $\overline{EA}$  and Memory Access Control HCR1.1.

### P3.6 Port 3 bit 6 control.

bits 5-4

| P36H | P36L |                   |
|------|------|-------------------|
| 0    | 0    | Standard 8051     |
| 0    | 1    | CMOS Output       |
| 1    | 0    | Open Drain Output |
| 1    | 1    | Input             |

NOTE: Port 3.6 also controlled by  $\overline{EA}$  and Memory Access Control HCR1.1.

### P3.5 Port 3 bit 5 control.

bits 3-2

| P35H | P35L |                   |
|------|------|-------------------|
| 0    | 0    | Standard 8051     |
| 0    | 1    | CMOS Output       |
| 1    | 0    | Open Drain Output |
| 1    | 1    | Input             |

### P3.4 Port 3 bit 4 control.

bits 1-0

| P34H | P34L |                   |
|------|------|-------------------|
| 0    | 0    | Standard 8051     |
| 0    | 1    | CMOS Output       |
| 1    | 0    | Open Drain Output |
| 1    | 1    | Input             |

## DAC Low Byte (DACL)

|                     | 7 | 6 | 5 | 4 | 3 | 2 | 1 | 0 | Reset Value     |
|---------------------|---|---|---|---|---|---|---|---|-----------------|
| SFR B5 <sub>H</sub> |   |   |   |   |   |   |   |   | 00 <sub>H</sub> |

### DACL7-0 Least Significant Bit Register for DAC0-3 and DAC Control (0 and 2).

bits 7-0

## DAC High Byte (DACH)

|                     | 7 | 6 | 5 | 4 | 3 | 2 | 1 | 0 | Reset Value     |
|---------------------|---|---|---|---|---|---|---|---|-----------------|
| SFR B6 <sub>H</sub> |   |   |   |   |   |   |   |   | 00 <sub>H</sub> |

### DACH7-0 Most Significant Byte Register for DAC0-3 and DAC Control (1 and 3).

bits 7-0

## DAC Select Register (DACSEL)

|                     | 7     | 6     | 5     | 4     | 3     | 2     | 1     | 0     | Reset Value     |
|---------------------|-------|-------|-------|-------|-------|-------|-------|-------|-----------------|
| SFR B7 <sub>H</sub> | DSEL7 | DSEL6 | DSEL5 | DSEL4 | DSEL3 | DSEL2 | DSEL1 | DSEL0 | 00 <sub>H</sub> |

**DSEL7-0 DAC and DAC Control Select.** The DACSEL register selects which DAC output register or which DAC control register is accessed by the DACL and DACH registers.

| DACSEL (B7 <sub>H</sub> ) | DACH (B6 <sub>H</sub> ) | DACL (B5 <sub>H</sub> ) | RESET VALUE       |
|---------------------------|-------------------------|-------------------------|-------------------|
| 00 <sub>H</sub>           | DAC0 (high)             | DAC0 (low)              | 0000 <sub>H</sub> |
| 01 <sub>H</sub>           | DAC1 (high)             | DAC1 (low)              | 0000 <sub>H</sub> |
| 02 <sub>H</sub>           | DAC2 (high)             | DAC2 (low)              | 0000 <sub>H</sub> |
| 03 <sub>H</sub>           | DAC3 (high)             | DAC3 (low)              | 0000 <sub>H</sub> |
| 04 <sub>H</sub>           | DACCON1                 | DACCON0                 | 6363 <sub>H</sub> |
| 05 <sub>H</sub>           | DACCON3                 | DACCON2                 | 0303 <sub>H</sub> |
| 06 <sub>H</sub>           | —                       | LOADCON                 | --00 <sub>H</sub> |
| 07 <sub>H</sub>           | —                       | —                       | —                 |

## DAC0 Control Register (DACCON0)

| DACSEL = 04 <sub>H</sub> | 7    | 6    | 5        | 4 | 3 | 2       | 1      | 0      | Reset Value     |
|--------------------------|------|------|----------|---|---|---------|--------|--------|-----------------|
| SFR B5 <sub>H</sub>      | COR0 | EOD0 | IDAC0DIS | 0 | 0 | SELREF0 | DOM0_1 | DOM0_0 | 63 <sub>H</sub> |

### COR0 Current Over Range on DAC0

bit 7 Write: 0 = Clear to release from high-impedance state back to normal mode unless an over-range condition exists.  
1 = NOP

Read: 0 = No current over range for DAC0.  
1 = COR0 signal after 3ms filter (EOD0 = 1) or raw signal (EOD0 = 0).

### EOD0 Enable Over-Current Detection

bit 6 0 = Disable over-current detection.  
1 = Enable over-current detection (default).

### IDAC0DIS IDAC0 Disable (for DOM0 = 00)

bit 5 0 = IDAC on mode for DAC0.  
1 = IDAC off mode for DAC0 (default).

### Not Used

bits 4-3

### SELREF0 Select the Reference Voltage for DAC0 Voltage Reference.

bit 2 0 = DAC0  $V_{REF} = AV_{DD}$  (default).  
1 = DAC0  $V_{REF} =$  internal  $V_{REF}$ .

### DOM0\_1-0 DAC Output Mode DAC0.

bits 1-0

| DOM0 | OUTPUT MODE FOR DAC0  |
|------|---|
| 00   | Normal VDAC output, IDAC controlled by IDAC0DIS bit.                |
| 01   | Power-Down mode—VDAC output off 1k $\Omega$ to AGND, IDAC off.      |
| 10   | Power-Down mode—VDAC output off 100k $\Omega$ to AGND, IDAC off.    |
| 11   | Power-Down mode—VDAC output off high impedance, IDAC off (default). |

## DAC1 Control Register (DACCON1)

| DACSEL = 04 <sub>H</sub> | 7    | 6    | 5        | 4 | 3 | 2       | 1      | 0      | Reset Value     |
|--------------------------|------|------|----------|---|---|---------|--------|--------|-----------------|
| SFR B6 <sub>H</sub>      | COR1 | EOD1 | IDAC1DIS | 0 | 0 | SELREF1 | DOM1_1 | DOM1_0 | 63 <sub>H</sub> |

### COR1 Current Over Range on DAC1

bit 7 Write: 0 = Clear to release from high-impedance state back to normal mode unless an over-range condition exists.  
1 = NOP

Read: 0 = No current over range for DAC1.  
1 = COR1 signal after 3ms filter (EOD1 = 1) or raw signal (EOD1 = 0).

### EOD1 Enable Over-Current Detection

bit 6 0 = Disable over-current detection.  
1 = Enable over-current detection (default).

### IDAC1DIS IDAC1 Disable (for DOM1 = 00)

bit 5 0 = IDAC on mode for DAC1.  
1 = IDAC off mode for DAC1 (default).

### Not Used

bits 4-3

### SELREF1 Select the Reference Voltage for DAC1 Voltage Reference.

bit 2 0 = DAC1  $V_{REF} = AV_{DD}$  (default).  
1 = DAC1  $V_{REF} =$  internal  $V_{REF}$ .

### DOM1\_1-0 DAC Output Mode DAC1.

bits 1-0

| DOM1 | OUTPUT MODE FOR DAC1  |
|------|---|
| 00   | Normal VDAC output, IDAC controlled by IDAC1DIS bit.                |
| 01   | Power-Down mode—VDAC output off 1k $\Omega$ to AGND, IDAC off.      |
| 10   | Power-Down mode—VDAC output off 100k $\Omega$ to AGND, IDAC off.    |
| 11   | Power-Down mode—VDAC output off high impedance, IDAC off (default). |

### DAC2 Control Register (DACCON2)

| DACSEL = 05 <sub>H</sub> | 7 | 6 | 5 | 4 | 3 | 2       | 1      | 0      | Reset Value     |
|--------------------------|---|---|---|---|---|---------|--------|--------|-----------------|
| SFR B5 <sub>H</sub>      | 0 | 0 | 0 | 0 | 0 | SELREF2 | DOM2_1 | DOM2_0 | 03 <sub>H</sub> |

#### SELREF2 Select the Reference Voltage for DAC2 Voltage Reference.

bit 2 0 = DAC2  $V_{REF} = AV_{DD}$  (default).  
 1 = DAC2  $V_{REF} =$  internal  $V_{REF}$ .

#### DOM2\_1-0 DAC Output Mode DAC2.

bits 1-0

| DOM2 | OUTPUT MODE FOR DAC2  |
|------|---|
| 00   | Normal VDAC output.   |
| 01   | Power-Down mode—VDAC output off 1k $\Omega$ to AGND, IDAC off.      |
| 10   | Power-Down mode—VDAC output off 100k $\Omega$ to AGND, IDAC off.    |
| 11   | Power-Down mode—VDAC output off high impedance, IDAC off (default). |

### DAC3 Control Register (DACCON3)

| DACSEL = 05 <sub>H</sub> | 7 | 6 | 5 | 4 | 3 | 2       | 1      | 0      | Reset Value     |
|--------------------------|---|---|---|---|---|---------|--------|--------|-----------------|
| SFR B6 <sub>H</sub>      | 0 | 0 | 0 | 0 | 0 | SELREF3 | DOM3_1 | DOM3_0 | 03 <sub>H</sub> |

#### SELREF3 Select the Reference Voltage for DAC3 Voltage Reference.

bit 2 0 = DAC2  $V_{REF} = AV_{DD}$  (default).  
 1 = DAC2  $V_{REF} =$  internal  $V_{REF}$ .

#### DOM3\_1-0 DAC Output Mode DAC3.

bits 1-0

| DOM2 | OUTPUT MODE FOR DAC2  |
|------|---|
| 00   | Normal VDAC output.   |
| 01   | Power-Down mode—VDAC output off 1k $\Omega$ to AGND, IDAC off.      |
| 10   | Power-Down mode—VDAC output off 100k $\Omega$ to AGND, IDAC off.    |
| 11   | Power-Down mode—VDAC output off high impedance, IDAC off (default). |

### DAC Load Control Register (LOADCON)

| DACSEL = 06 <sub>H</sub> | 7       | 6       | 5       | 4       | 3       | 2       | 1       | 0       | Reset Value     |
|--------------------------|---------|---------|---------|---------|---------|---------|---------|---------|-----------------|
| SFR B5 <sub>H</sub>      | D3LOAD1 | D3LOAD0 | D2LOAD1 | D2LOAD0 | D1LOAD1 | D1LOAD0 | D0LOAD1 | D0LOAD0 | 00 <sub>H</sub> |

#### D3LOAD1-0 DAC Load Options.

bit 7-6

#### D2LOAD1-0

bit 5-4

#### D1LOAD1-0

bit 3-2

#### D0LOAD1-0

bit 1-0

| DxLOAD | OUTPUT MODE FOR DACx  |
|--------|---|
| 00     | Direct load: write to DACxL directly loads the DAC buffer and the DAC output (write to DACxH does not load DAC output).   |
| 01     | Delay load: the values last written to DACxL/DACxH will be transferred to the DAC output on the next MSEC timer tick.   |
| 10     | Delay load: the values last written to DACxL/DACxH will be transferred to the DAC output on the next HMSEC timer tick.  |
| 11     | Sync load: the values contained in the DACxL/DACxH registers will be transferred to the DAC output immediately after 11 <sub>B</sub> is written to this register. |

## Interrupt Priority (IP)

|                     | 7 | 6   | 5   | 4   | 3   | 2   | 1   | 0   | Reset Value     |
|---------------------|---|-----|-----|-----|-----|-----|-----|-----|-----------------|
| SFR B8 <sub>H</sub> | 1 | PS1 | PT2 | PS0 | PT1 | PX1 | PT0 | PX0 | 80 <sub>H</sub> |

**PS1** **Serial Port 1 Interrupt.** This bit controls the priority of the serial Port 1 interrupt.  
 bit 6 0 = Serial Port 1 priority is determined by the natural priority order.  
 1 = Serial Port 1 is a high priority interrupt.

**PT2** **Timer 2 Interrupt.** This bit controls the priority of the Timer 2 interrupt.  
 bit 5 0 = Timer 2 priority is determined by the natural priority order.  
 1 = Timer 2 priority is a high priority interrupt.

**PS0** **Serial Port 0 Interrupt.** This bit controls the priority of the serial Port 0 interrupt.  
 bit 4 0 = Serial Port 0 priority is determined by the natural priority order.  
 1 = Serial Port 0 is a high priority interrupt.

**PT1** **Timer 1 Interrupt.** This bit controls the priority of the Timer 1 interrupt.  
 bit 3 0 = Timer 1 priority is determined by the natural priority order.  
 1 = Timer 1 priority is a high priority interrupt.

**PX1** **External Interrupt 1.** This bit controls the priority of external interrupt 1.  
 bit 2 0 = External interrupt 1 priority is determined by the natural priority order.  
 1 = External interrupt 1 is a high priority interrupt.

**PT0** **Timer 0 Interrupt.** This bit controls the priority of the Timer 0 interrupt.  
 bit 1 0 = Timer 0 priority is determined by the natural priority order.  
 1 = Timer 0 priority is a high priority interrupt.

**PX0** **External Interrupt 0.** This bit controls the priority of external interrupt 0.  
 bit 0 0 = External interrupt 0 priority is determined by the natural priority order.  
 1 = External interrupt 0 is a high priority interrupt.

## Serial Port 1 Control (SCON1)

|                     | 7     | 6     | 5     | 4     | 3     | 2     | 1    | 0    | Reset Value     |
|---------------------|-------|-------|-------|-------|-------|-------|------|------|-----------------|
| SFR C0 <sub>H</sub> | SM0_1 | SM1_1 | SM2_1 | REN_1 | TB8_1 | RB8_1 | TI_1 | RI_1 | 00 <sub>H</sub> |

**SM0-2** **Serial Port 1 Mode.** These bits control the mode of serial Port 1. Modes 1, 2, and 3 have 1 start and 1 stop bit in addition to the 8 or 9 data bits.  
 bits 7-5

| MODE             | SM0 | SM1 | SM2 | FUNCTION                                       | LENGTH  | PERIOD   |
|------------------|-----|-----|-----|--|---------|--|
| 0                | 0   | 0   | 0   | Synchronous                                    | 8 bits  | 12 p <sub>CLK</sub> <sup>(1)</sup>   |
| 0                | 0   | 0   | 1   | Synchronous                                    | 8 bits  | 4 p <sub>CLK</sub> <sup>(1)</sup>  |
| 1 <sup>(2)</sup> | 0   | 1   | x   | Asynchronous                                   | 10 bits | Timer 1 or 2 Baud Rate Equation  |
| 2                | 1   | 0   | 0   | Asynchronous                                   | 11 bits | 64 p <sub>CLK</sub> <sup>(1)</sup> (SMOD = 0)<br>32 p <sub>CLK</sub> <sup>(1)</sup> (SMOD = 1) |
| 2                | 1   | 0   | 1   | Asynchronous with Multiprocessor Communication | 11 bits | 64 p <sub>CLK</sub> <sup>(1)</sup> (SMOD = 0)<br>32 p <sub>CLK</sub> <sup>(1)</sup> (SMOD = 1) |
| 3 <sup>(2)</sup> | 1   | 1   | 0   | Asynchronous                                   | 11 bits | Timer 1 or 2 Baud Rate Equation  |
| 3 <sup>(2)</sup> | 1   | 1   | 1   | Asynchronous with Multiprocessor Communication | 11 bits | Timer 1 or 2 Baud Rate Equation  |

NOTE: (1) p<sub>CLK</sub> will be equal to t<sub>CLK</sub>, except that p<sub>CLK</sub> will stop for IDLE. (2) For modes 1 and 3, the selection of Timer 1 or 2 for baud rate is specified via the SCON register.

**REN\_1** **Receive Enable.** This bit enables/disables the serial Port 1 received shift register.  
 bit 4 0 = Serial Port 1 reception disabled.  
 1 = Serial Port 1 received enabled (modes 1, 2, and 3). Initiate synchronous reception (mode 0).

**TB8\_1** **9th Transmission Bit State.** This bit defines the state of the 9th transmission bit in serial Port 1 modes 2 and 3.  
 bit 3

**RB8\_1** **9th Received Bit State.** This bit identifies the state of the 9th reception bit of received data in serial Port 1 modes 2 and 3. In serial port mode 1, when SM2\_1 = 0, RB8\_1 is the state of the stop bit. RB8\_1 is not used in mode 0.  
 bit 2

**TI\_1** **Transmitter Interrupt Flag.** This bit indicates that data in the serial Port 1 buffer has been completely shifted out. In serial port mode 0, TI\_1 is set at the end of the 8th data bit. In all other modes, this bit is set at the end of the last data bit. This bit must be cleared by software to transmit the next byte.  
 bit 1

**RI\_1** **Receiver Interrupt Flag.** This bit indicates that a byte of data has been received in the serial Port 1 buffer. In serial port mode 0, RI\_1 is set at the end of the 8th bit. In serial port mode 1, RI\_1 is set after the last sample of the incoming stop bit subject to the state of SM2\_1. In modes 2 and 3, RI\_1 is set after the last sample of RB8\_1. This bit must be cleared by software to receive the next byte.

### Serial Data Buffer 1 (SBUF1)

|                     |   |   |   |   |   |   |   |   |                    |
|---------------------|---|---|---|---|---|---|---|---|--------------------|
|                     | 7 | 6 | 5 | 4 | 3 | 2 | 1 | 0 | <b>Reset Value</b> |
| SFR C1 <sub>H</sub> |   |   |   |   |   |   |   |   | 00 <sub>H</sub>    |

**SBUF1.7-0 Serial Data Buffer 1.** Data for serial Port 1 is read from or written to this location. The serial transmit and receive bits 7-0 buffers are separate registers, but both are addressed at this location.

### Enable Wake Up (EWU) Waking Up from IDLE Mode

|                     |   |   |   |   |   |        |        |        |                    |
|---------------------|---|---|---|---|---|--------|--------|--------|--------------------|
|                     | 7 | 6 | 5 | 4 | 3 | 2      | 1      | 0      | <b>Reset Value</b> |
| SFR C6 <sub>H</sub> | — | — | — | — | — | EWUWDT | EWUEX1 | EWUEX0 | 00 <sub>H</sub>    |

Auxiliary interrupts will wake up from IDLE. They are enabled with EAI (EICON.5).

**EWUWDT Enable Wake Up Watchdog Timer.** Wake using watchdog timer interrupt.  
 bit 2 0 = Don't wake up on watchdog timer interrupt.  
 1 = Wake up on watchdog timer interrupt.

**EWUEX1 Enable Wake Up External 1.** Wake using external interrupt source 1.  
 bit 1 0 = Don't wake up on external interrupt source 1.  
 1 = Wake up on external interrupt source 1.

**EWUEX0 Enable Wake Up External 0.** Wake using external interrupt source 0.  
 bit 0 0 = Don't wake up on external interrupt source 0.  
 1 = Wake up on external interrupt source 0.

### System Clock Divider Register (SYSCCLK)

|                     |   |   |         |         |   |      |      |      |                    |
|---------------------|---|---|---------|---------|---|------|------|------|--------------------|
|                     | 7 | 6 | 5       | 4       | 3 | 2    | 1    | 0    | <b>Reset Value</b> |
| SFR C7 <sub>H</sub> | 0 | 0 | DIVMOD1 | DIVMOD0 | 0 | DIV2 | DIV1 | DIV0 | 00 <sub>H</sub>    |

#### DIVMOD1-0 Clock Divide Mode

bits 5-4 Write:

| DIVMOD | DIVIDE MODE   |
|--------|---|
| 00     | Normal mode (default, no divide)  |
| 01     | Immediate mode: start divide immediately, return to Normal mode on IDLE wakeup condition..  |
| 10     | Delay mode: same as Immediate mode, except that the mode changes with the millisecond interrupt (MSINT). If MSINT is enabled, the divide will start on the next MSINT and return to normal mode on the following MSINT. If MSINT is not enabled, the divide will start on the next MSINT condition (even if masked) but will not leave the divide mode until the MSINT counter overflows, which follows a wakeup condition. |
| 11     | Reserved  |

Read:

| DIVMOD | DIVISION MODE STATUS         |
|--------|------------------------------|
| 00     | No divide                    |
| 01     | Divider is in Immediate mode |
| 10     | Divider is in Delay mode     |
| 11     | Reserved                     |

#### NOTE:

Do not clear the DIVMOD register to exit Immediate or Delay modes. Exit these modes only through the appropriate interrupt (the interrupt can be either normally generated or software generated).

#### DIV2-0 Divide Mode

bit 2-0

| DIV | DIVISOR               |
|-----|-----------------------|
| 000 | Divide by 2 (default) |
| 001 | Divide by 4           |
| 010 | Divide by 8           |
| 011 | Divide by 16          |
| 100 | Divide by 32          |
| 101 | Divide by 1024        |
| 110 | Divide by 2048        |
| 111 | Divide by 4096        |

## Timer 2 Control (T2CON)

|                     | 7   | 6    | 5    | 4    | 3     | 2   | 1    | 0      | Reset Value     |
|---------------------|-----|------|------|------|-------|-----|------|--------|-----------------|
| SFR C8 <sub>H</sub> | TF2 | EXF2 | RCLK | TCLK | EXEN2 | TR2 | C/T2 | CP/RL2 | 00 <sub>H</sub> |

**TF2** bit 7 **Timer 2 Overflow Flag.** This flag will be set when Timer 2 overflows from FFFF<sub>H</sub>. It must be cleared by software. TF2 will only be set if RCLK and TCLK are both cleared to 0. Writing a 1 to TF2 forces a Timer 2 interrupt if enabled.

**EXF2** bit 6 **Timer 2 External Flag.** A negative transition on the T2EX pin (P1.1) will cause this flag to be set based on the EXEN2 (T2CON.3) bit. If set by a negative transition, this flag must be cleared to 0 by software. Setting this bit in software will force a timer interrupt if enabled.

**RCLK** bit 5 **Receive Clock Flag.** This bit determines the serial Port 0 timebase when receiving data in serial modes 1 or 3.  
 0 = Timer 1 overflow is used to determine receiver baud rate for UART0.  
 1 = Timer 2 overflow is used to determine receiver baud rate for UART0.  
 Setting this bit will force Timer 2 into baud rate generation mode. The timer will operate from a divide by 2 of the external clock.

**TCLK** bit 4 **Transmit Clock Flag.** This bit determines the serial Port 0 timebase when transmitting data in serial modes 1 or 3.  
 0 = Timer 1 overflow is used to determine transmitter baud rate for UART0.  
 1 = Timer 2 overflow is used to determine transmitter baud rate for UART0.  
 Setting this bit will force Timer 2 into baud rate generation mode. The timer will operate from a divide by 2 of the external clock.

**EXEN2** bit 3 **Timer 2 External Enable.** This bit enables the capture/reload function on the T2EX pin if Timer 2 is not generating baud rates for the serial port.  
 0 = Timer 2 will ignore all external events at T2EX.  
 1 = Timer 2 will capture or reload a value if a negative transition is detected on the T2EX pin.

**TR2** bit 2 **Timer 1 Run Control.** This bit enables/disables the operation of Timer 2. Halting this timer will preserve the current count in TH2, TL2.  
 0 = Timer 2 is halted.  
 1 = Timer 2 is enabled.

**C/T2** bit 1 **Counter/Timer Select.** This bit determines whether Timer 2 will function as a timer or counter. Independent of this bit, Timer 2 runs at 2 clocks per tick when used in baud rate generator mode.  
 0 = Timer 2 functions as a timer. The speed of Timer 2 is determined by the T2M bit (CKCON.5).  
 1 = Timer 2 will count negative transitions on the T2 pin (P1.0).

**CP/RL2** bit 0 **Capture/Reload Select.** This bit determines whether the capture or reload function will be used for Timer 2. If either RCLK or TCLK is set, this bit will not function and the timer will function in an auto-reload mode following each overflow.  
 0 = Auto-reloads will occur when Timer 2 overflows or a falling edge is detected on T2EX if EXEN2 = 1.  
 1 = Timer 2 captures will occur when a falling edge is detected on T2EX if EXEN2 = 1.

## Timer 2 Capture LSB (RCAP2L)

|                     | 7 | 6 | 5 | 4 | 3 | 2 | 1 | 0 | Reset Value     |
|---------------------|---|---|---|---|---|---|---|---|-----------------|
| SFR CA <sub>H</sub> |   |   |   |   |   |   |   |   | 00 <sub>H</sub> |

**RCAP2L** bits 7-0 **Timer 2 Capture LSB.** This register is used to capture the TL2 value when Timer 2 is configured in capture mode. RCAP2L is also used as the LSB of a 16-bit reload value when Timer 2 is configured in auto-reload mode.

### Timer 2 Capture MSB (RCAP2H)

|                     |   |   |   |   |   |   |   |   |                 |
|---------------------|---|---|---|---|---|---|---|---|-----------------|
|                     | 7 | 6 | 5 | 4 | 3 | 2 | 1 | 0 | Reset Value     |
| SFR CB <sub>H</sub> |   |   |   |   |   |   |   |   | 00 <sub>H</sub> |

**RCAP2H**      **Timer 2 Capture MSB.** This register is used to capture the TH2 value when Timer 2 is configured in capture mode. RCAP2H is also used as the MSB of a 16-bit reload value when Timer 2 is configured in auto-reload mode.  
bits 7-0

### Timer 2 LSB (TL2)

|                     |   |   |   |   |   |   |   |   |                 |
|---------------------|---|---|---|---|---|---|---|---|-----------------|
|                     | 7 | 6 | 5 | 4 | 3 | 2 | 1 | 0 | Reset Value     |
| SFR CC <sub>H</sub> |   |   |   |   |   |   |   |   | 00 <sub>H</sub> |

**TL2**      **Timer 2 LSB.** This register contains the least significant byte of Timer 2.  
bits 7-0

### Timer 2 MSB (TH2)

|                     |   |   |   |   |   |   |   |   |                 |
|---------------------|---|---|---|---|---|---|---|---|-----------------|
|                     | 7 | 6 | 5 | 4 | 3 | 2 | 1 | 0 | Reset Value     |
| SFR CD <sub>H</sub> |   |   |   |   |   |   |   |   | 00 <sub>H</sub> |

**TH2**      **Timer 2 MSB.** This register contains the most significant byte of Timer 2.  
bits 7-0

### Program Status Word (PSW)

|                     |    |    |    |     |     |    |    |   |                 |
|---------------------|----|----|----|-----|-----|----|----|---|-----------------|
|                     | 7  | 6  | 5  | 4   | 3   | 2  | 1  | 0 | Reset Value     |
| SFR D0 <sub>H</sub> | CY | AC | F0 | RS1 | RS0 | OV | F1 | P | 00 <sub>H</sub> |

**CY**      **Carry Flag.** This bit is set when the last arithmetic operation resulted in a carry (during addition) or a borrow (during subtraction). Otherwise it is cleared to 0 by all arithmetic operations.  
bit 7

**AC**      **Auxiliary Carry Flag.** This bit is set to 1 if the last arithmetic operation resulted in a carry into (during addition), or a borrow (during subtraction) from the high order nibble. Otherwise it is cleared to 0 by all arithmetic operations.  
bit 6

**F0**      **User Flag 0.** This is a bit-addressable, general-purpose flag for software control.  
bit 5

**RS1, RS0**      **Register Bank Select 1-0.** These bits select which register bank is addressed during register accesses.  
bits 4-3

| RS1 | RS0 | REGISTER BANK | ADDRESS                          |
|-----|-----|---------------|----------------------------------|
| 0   | 0   | 0             | 00 <sub>H</sub> -07 <sub>H</sub> |
| 0   | 1   | 1             | 08 <sub>H</sub> -0F <sub>H</sub> |
| 1   | 0   | 2             | 10 <sub>H</sub> -17 <sub>H</sub> |
| 1   | 1   | 3             | 18 <sub>H</sub> -1F <sub>H</sub> |

**OV**      **Overflow Flag.** This bit is set to 1 if the last arithmetic operation resulted in a carry (addition), borrow (subtraction), or overflow (multiply or divide). Otherwise it is cleared to 0 by all arithmetic operations.  
bit 2

**F1**      **User Flag 1.** This is a bit-addressable, general-purpose flag for software control.  
bit 1

**P**      **Parity Flag.** This bit is set to 1 if the modulo-2 sum of the 8 bits of the accumulator is 1 (odd parity); and cleared to 0 on even parity.  
bit 0

### ADC Offset Calibration Register Low Byte (OCL)

|                     |   |   |   |   |   |   |   |   |                 |
|---------------------|---|---|---|---|---|---|---|---|-----------------|
|                     | 7 | 6 | 5 | 4 | 3 | 2 | 1 | 0 | Reset Value     |
| SFR D1 <sub>H</sub> |   |   |   |   |   |   |   |   | 00 <sub>H</sub> |

**OCL**      **ADC Offset Calibration Register Low Byte.** This is the low byte of the 24-bit word that contains the ADC offset calibration. A value which is written to this location will set the ADC offset calibration value.  
bits 7-0

### ADC Offset Calibration Register Middle Byte (OCM)

|                     |   |   |   |   |   |   |   |   |                 |
|---------------------|---|---|---|---|---|---|---|---|-----------------|
|                     | 7 | 6 | 5 | 4 | 3 | 2 | 1 | 0 | Reset Value     |
| SFR D2 <sub>H</sub> |   |   |   |   |   |   |   |   | 00 <sub>H</sub> |

**OCM** ADC Offset Calibration Register Middle Byte. This is the middle byte of the 24-bit word that contains the ADC offset calibration. A value which is written to this location will set the ADC offset calibration value.

### ADC Offset Calibration Register High Byte (OCH)

|                     |   |   |   |   |   |   |   |   |                 |
|---------------------|---|---|---|---|---|---|---|---|-----------------|
|                     | 7 | 6 | 5 | 4 | 3 | 2 | 1 | 0 | Reset Value     |
| SFR D3 <sub>H</sub> |   |   |   |   |   |   |   |   | 00 <sub>H</sub> |

**OCH** ADC Offset Calibration Register High Byte. This is the high byte of the 24-bit word that contains the ADC offset calibration. A value which is written to this location will set the ADC offset calibration value.

### ADC Gain Calibration Register Low Byte (GCL)

|                     |   |   |   |   |   |   |   |   |                 |
|---------------------|---|---|---|---|---|---|---|---|-----------------|
|                     | 7 | 6 | 5 | 4 | 3 | 2 | 1 | 0 | Reset Value     |
| SFR D4 <sub>H</sub> |   |   |   |   |   |   |   |   | 5A <sub>H</sub> |

**GCL** ADC Gain Calibration Register Low Byte. This is the low byte of the 24-bit word that contains the ADC gain calibration. A value which is written to this location will set the ADC gain calibration value.

### ADC Gain Calibration Register Middle Byte (GCM)

|                     |   |   |   |   |   |   |   |   |                 |
|---------------------|---|---|---|---|---|---|---|---|-----------------|
|                     | 7 | 6 | 5 | 4 | 3 | 2 | 1 | 0 | Reset Value     |
| SFR D5 <sub>H</sub> |   |   |   |   |   |   |   |   | EC <sub>H</sub> |

**GCM** ADC Gain Calibration Register Middle Byte. This is the middle byte of the 24-bit word that contains the ADC gain calibration. A value which is written to this location will set the ADC gain calibration value.

### ADC Gain Calibration Register High Byte (GCH)

|                     |   |   |   |   |   |   |   |   |                 |
|---------------------|---|---|---|---|---|---|---|---|-----------------|
|                     | 7 | 6 | 5 | 4 | 3 | 2 | 1 | 0 | Reset Value     |
| SFR D6 <sub>H</sub> |   |   |   |   |   |   |   |   | 5F <sub>H</sub> |

**GCH** ADC Gain Calibration Register High Byte. This is the high byte of the 24-bit word that contains the ADC gain calibration. A value which is written to this location will set the ADC gain calibration value.

### ADC Multiplexer Register (ADMUX)

|                     |      |      |      |      |      |      |      |      |                 |
|---------------------|------|------|------|------|------|------|------|------|-----------------|
|                     | 7    | 6    | 5    | 4    | 3    | 2    | 1    | 0    | Reset Value     |
| SFR D7 <sub>H</sub> | INP3 | INP2 | INP1 | INP0 | INN3 | INN2 | INN1 | INN0 | 01 <sub>H</sub> |

**INP3-0** Input Multiplexer Positive Channel. This selects the positive signal input.  
bits 7-4

| INP3 | INP2 | INP1 | INP0 | POSITIVE INPUT   |
|------|------|------|------|--|
| 0    | 0    | 0    | 0    | AIN0 (default)   |
| 0    | 0    | 0    | 1    | AIN1   |
| 0    | 0    | 1    | 0    | AIN2   |
| 0    | 0    | 1    | 1    | AIN3   |
| 0    | 1    | 0    | 0    | AIN4   |
| 0    | 1    | 0    | 1    | AIN5   |
| 0    | 1    | 1    | 0    | AIN6   |
| 0    | 1    | 1    | 1    | AIN7   |
| 1    | 0    | 0    | 0    | AINCOM   |
| 1    | 1    | 1    | 1    | Temperature Sensor (Requires ADMUX = FF <sub>H</sub> ) |

**INN3-0**  
bits 3-0

**Input Multiplexer Negative Channel.** This selects the negative signal input.

| INN3 | INN2 | INN1 | INN0 | NEGATIVE INPUT   |
|------|------|------|------|--|
| 0    | 0    | 0    | 0    | AIN0   |
| 0    | 0    | 0    | 1    | AIN1 (default)   |
| 0    | 0    | 1    | 0    | AIN2   |
| 0    | 0    | 1    | 1    | AIN3   |
| 0    | 1    | 0    | 0    | AIN4   |
| 0    | 1    | 0    | 1    | AIN5   |
| 0    | 1    | 1    | 0    | AIN6   |
| 0    | 1    | 1    | 1    | AIN7   |
| 1    | 0    | 0    | 0    | AINCOM   |
| 1    | 1    | 1    | 1    | Temperature Sensor (Requires ADMUX = FF <sub>H</sub> ) |

### Enable Interrupt Control (EICON)

|                     | 7     | 6 | 5   | 4  | 3    | 2 | 1 | 0 | Reset Value     |
|---------------------|-------|---|-----|----|------|---|---|---|-----------------|
| SFR D8 <sub>H</sub> | SMOD1 | 1 | EAI | AI | WDTI | 0 | 0 | 0 | 40 <sub>H</sub> |

**SMOD1** **Serial Port 1 Mode.** When this bit is set the serial baud rate for Port 1 will be doubled.  
bit 7  
0 = Standard baud rate for Port 1 (default).  
1 = Double baud rate for Port 1.

**EAI** **Enable Auxiliary Interrupt.** The Auxiliary Interrupt accesses nine different interrupts which are masked and identified by SFR registers PAI (SFR A5<sub>H</sub>), AIE (SFR A6<sub>H</sub>), and AISTAT (SFR A7<sub>H</sub>).  
bit 5  
0 = Auxiliary Interrupt disabled (default).  
1 = Auxiliary Interrupt enabled.

**AI** **Auxiliary Interrupt Flag.** AI must be cleared by software before exiting the interrupt service routine, after the source of the interrupt is cleared. Otherwise, the interrupt occurs again. Setting AI in software generates an Auxiliary Interrupt, if enabled.  
bit 4  
0 = No Auxiliary Interrupt detected (default).  
1 = Auxiliary Interrupt detected.

**WDTI** **Watchdog Timer Interrupt Flag.** WDTI must be cleared by software before exiting the interrupt service routine. Otherwise, the interrupt occurs again. Setting WDTI in software generates a watchdog time interrupt, if enabled. The Watchdog timer can generate an interrupt or reset. The interrupt is available only if the reset action is disabled in HCR0.  
bit 3  
0 = No Watchdog Timer Interrupt Detected (default).  
1 = Watchdog Timer Interrupt Detected.

### ADC Results Register Low Byte (ADRESL)

|                     | 7 | 6 | 5 | 4 | 3 | 2 | 1 | 0 | Reset Value     |
|---------------------|---|---|---|---|---|---|---|---|-----------------|
| SFR D9 <sub>H</sub> |   |   |   |   |   |   |   |   | 00 <sub>H</sub> |

**ADRESL** **The ADC Results Low Byte.** This is the low byte of the 24-bit word that contains the ADC Converter Results. Reading from this register clears the ADC interrupt.  
bits 7-0

### ADC Results Register Middle Byte (ADRESM)

|                     | 7 | 6 | 5 | 4 | 3 | 2 | 1 | 0 | Reset Value     |
|---------------------|---|---|---|---|---|---|---|---|-----------------|
| SFR DA <sub>H</sub> |   |   |   |   |   |   |   |   | 00 <sub>H</sub> |

**ADRESM** **The ADC Results Middle Byte.** This is the middle byte of the 24-bit word that contains the ADC Converter Results.  
bits 7-0

### ADC Results Register High Byte (ADRESH)

|                     | 7 | 6 | 5 | 4 | 3 | 2 | 1 | 0 | Reset Value     |
|---------------------|---|---|---|---|---|---|---|---|-----------------|
| SFR DB <sub>H</sub> |   |   |   |   |   |   |   |   | 00 <sub>H</sub> |

**ADRESH** **The ADC Results High Byte.** This is the high byte of the 24-bit word that contains the ADC Converter Results.  
bits 7-0

### ADC Control Register 0 (ADCON0)

|                     | 7 | 6   | 5     | 4     | 3    | 2    | 1    | 0    | Reset Value     |
|---------------------|---|-----|-------|-------|------|------|------|------|-----------------|
| SFR DC <sub>H</sub> | — | BOD | EVREF | VREFH | EBUF | PGA2 | PGA1 | PGA0 | 30 <sub>H</sub> |

**BOD** **Burnout Detect.** When enabled this connects a positive current source to the positive channel and a negative current source to the negative channel. If the channel is open circuit then the ADC results will be full-scale.

bit 6

0 = Burnout Current Sources Off (default).

1 = Burnout Current Sources On.

**EVREF** **Enable Internal Voltage Reference.** If the internal voltage reference is not used, it should be turned off to save power and reduce noise.

bit 5

0 = Internal Voltage Reference Off.

1 = Internal Voltage Reference On (default).

**VREFH** **Voltage Reference High Select.** The internal voltage reference can be selected to be 2.5V or 1.25V.

bit 4

0 = REFOUT/REF IN+ is 1.25V.

1 = REFOUT/REF IN+ is 2.5V (default).

**EBUF** **Enable Buffer.** Enable the input buffer to provide higher input impedance but limits the input voltage range and dissipates more power.

bit 3

0 = Buffer disabled (default).

1 = Buffer enabled.

**PGA2-0** **Programmable Gain Amplifier.** Sets the gain for the PGA from 1 to 128.

bits 2-0

| PGA2 | PGA1 | PGA0 | GAIN        |
|------|------|------|-------------|
| 0    | 0    | 0    | 1 (default) |
| 0    | 0    | 1    | 2           |
| 0    | 1    | 0    | 4           |
| 0    | 1    | 1    | 8           |
| 1    | 0    | 0    | 16          |
| 1    | 0    | 1    | 32          |
| 1    | 1    | 0    | 64          |
| 1    | 1    | 1    | 128         |

### ADC Control Register 1 (ADCON1)

|                     | 7 | 6   | 5   | 4   | 3 | 2    | 1    | 0    | Reset Value            |
|---------------------|---|-----|-----|-----|---|------|------|------|------------------------|
| SFR DD <sub>H</sub> | — | POL | SM1 | SM0 | — | CAL2 | CAL1 | CAL0 | x000 0000 <sub>B</sub> |

**POL** **Polarity.** Polarity of the ADC result and Summation register.

bit 6

0 = Bipolar.

1 = Unipolar.

| POL | ANALOG INPUT | DIGITAL OUTPUT |
|-----|--------------|----------------|
| 0   | +FSR         | 0x7FFFFFFF     |
|     | ZERO         | 0x000000       |
|     | -FSR         | 0x800000       |
| 1   | +FSR         | 0xFFFFFFFF     |
|     | ZERO         | 0x000000       |
|     | -FSR         | 0x000000       |

**SM1-0** **Settling Mode.** Selects the type of filter or auto select which defines the digital filter settling characteristics.

bits 5-4

| SM1 | SM0 | SETTLING MODE            |
|-----|-----|--------------------------|
| 0   | 0   | Auto                     |
| 0   | 1   | Fast Settling Filter     |
| 1   | 0   | Sinc <sup>2</sup> Filter |
| 1   | 1   | Sinc <sup>3</sup> Filter |

**CAL2-0 Calibration Mode Control Bits.**

bits 2-0

| CAL2 | CAL1 | CAL0 | CALIBRATION MODE                  |
|------|------|------|-----------------------------------|
| 0    | 0    | 0    | No Calibration (default)          |
| 0    | 0    | 1    | Self Calibration, Offset and Gain |
| 0    | 1    | 0    | Self Calibration, Offset Only     |
| 0    | 1    | 1    | Self Calibration, Gain Only       |
| 1    | 0    | 0    | System Calibration, Offset Only   |
| 1    | 0    | 1    | System Calibration, Gain Only     |
| 1    | 1    | 0    | Reserved                          |
| 1    | 1    | 1    | Reserved                          |

Read Value—000<sub>B</sub>.

**ADC Control Register 2 (ADCON2)**

|                     | 7   | 6   | 5   | 4   | 3   | 2   | 1   | 0   | Reset Value     |
|---------------------|-----|-----|-----|-----|-----|-----|-----|-----|-----------------|
| SFR DE <sub>H</sub> | DR7 | DR6 | DR5 | DR4 | DR3 | DR2 | DR1 | DR0 | 1B <sub>H</sub> |

**DR7-0 Decimation Ratio LSB.**

bits 7-0

**ADC Control Register 3 (ADCON3)**

|                     | 7 | 6 | 5 | 4 | 3 | 2    | 1   | 0   | Reset Value     |
|---------------------|---|---|---|---|---|------|-----|-----|-----------------|
| SFR DF <sub>H</sub> | — | — | — | — | — | DR10 | DR9 | DR8 | 06 <sub>H</sub> |

**DR10-8 Decimation Ratio Most Significant 3 Bits.** The output data rate = (ACLK + 1)/64/Decimation Ratio.

bits 2-0

**Accumulator (A or ACC)**

|                     | 7     | 6     | 5     | 4     | 3     | 2     | 1     | 0     | Reset Value     |
|---------------------|-------|-------|-------|-------|-------|-------|-------|-------|-----------------|
| SFR E0 <sub>H</sub> | ACC.7 | ACC.6 | ACC.5 | ACC.4 | ACC.3 | ACC.2 | ACC.1 | ACC.0 | 00 <sub>H</sub> |

**ACC.7-0 Accumulator.** This register serves as the accumulator for arithmetic and logic operations.

bits 7-0

**Summation/Shifter Control (SSCON)**

|                     | 7      | 6      | 5     | 4     | 3     | 2    | 1    | 0    | Reset Value     |
|---------------------|--------|--------|-------|-------|-------|------|------|------|-----------------|
| SFR E1 <sub>H</sub> | SSCON1 | SSCON0 | SCNT2 | SCNT1 | SCNT0 | SHF2 | SHF1 | SHF0 | 00 <sub>H</sub> |

The Summation register is powered down when the ADC is powered down. If all zeroes are written to this register the 32-bit SUMR3-0 registers will be cleared. The Summation registers will do sign extend if Bipolar is selected in ADCON1.

**SSCON1-0 Summation/Shift Control.**

bits 7-6

| SSCON1 | SSCON0 | SCNT2    | SCNT1    | SCNT0    | SHF2     | SHF1     | SHF0     | DESCRIPTION                                  |
|--------|--------|----------|----------|----------|----------|----------|----------|--|
| 0      | 0      | 0        | 0        | 0        | 0        | 0        | 0        | Clear Summation Register                     |
| 0      | 0      | 0        | 1        | 0        | 0        | 0        | 0        | CPU Summation on Write to SUMR0              |
| 0      | 0      | 1        | 0        | 0        | 0        | 0        | 0        | CPU Subtraction on Write to SUMR0            |
| 1      | 0      | x        | x        | x        | Note (1) | Note (1) | Note (1) | CPU Shift Only                               |
| 0      | 1      | Note (1) | Note (1) | Note (1) | x        | x        | x        | ADC Summation Only                           |
| 1      | 1      | Note (1) | Note (1) | Note (1) | Note (1) | Note (1) | Note (1) | ADC Summation Completes then Shift Completes |

NOTES: (1) Refer to register bit definition.

**SCNT2-0 Summation Count.** When the summation is complete an interrupt will be generated unless masked. Reading the SUMR0 register clears the interrupt.

bits 5-3

| SCNT2 | SCNT1 | SCNT0 | SUMMATION COUNT |
|-------|-------|-------|-----------------|
| 0     | 0     | 0     | 2               |
| 0     | 0     | 1     | 4               |
| 0     | 1     | 0     | 8               |
| 0     | 1     | 1     | 16              |
| 1     | 0     | 0     | 32              |
| 1     | 0     | 1     | 64              |
| 1     | 1     | 0     | 128             |
| 1     | 1     | 1     | 256             |

**SHF2-0 Shift Count.**

bits 2-0

| SHF2 | SHF1 | SHF0 | SHIFT | DIVIDE |
|------|------|------|-------|--------|
| 0    | 0    | 0    | 1     | 2      |
| 0    | 0    | 1    | 2     | 4      |
| 0    | 1    | 0    | 3     | 8      |
| 0    | 1    | 1    | 4     | 16     |
| 1    | 0    | 0    | 5     | 32     |
| 1    | 0    | 1    | 6     | 64     |
| 1    | 1    | 0    | 7     | 128    |
| 1    | 1    | 1    | 8     | 256    |

**Summation Register 0 (SUMR0)**

|                     | 7 | 6 | 5 | 4 | 3 | 2 | 1 | 0 | Reset Value     |
|---------------------|---|---|---|---|---|---|---|---|-----------------|
| SFR E2 <sub>H</sub> |   |   |   |   |   |   |   |   | 00 <sub>H</sub> |

**SUMR0 Summation Register 0.** This is the least significant byte of the 32-bit summation register or bits 0 to 7.

bits 7-0 Write: will cause values in SUMR3-0 to be added to the summation register.

Read: will clear the Summation Count Interrupt.

**Summation Register 1 (SUMR1)**

|                     | 7 | 6 | 5 | 4 | 3 | 2 | 1 | 0 | Reset Value     |
|---------------------|---|---|---|---|---|---|---|---|-----------------|
| SFR E3 <sub>H</sub> |   |   |   |   |   |   |   |   | 00 <sub>H</sub> |

**SUMR1 Summation Register 1.** This is the most significant byte of the lowest 16 bits of the summation register or bits 8-15.

bits 7-0

**Summation Register 2 (SUMR2)**

|                     | 7 | 6 | 5 | 4 | 3 | 2 | 1 | 0 | Reset Value     |
|---------------------|---|---|---|---|---|---|---|---|-----------------|
| SFR E4 <sub>H</sub> |   |   |   |   |   |   |   |   | 00 <sub>H</sub> |

**SUMR2 Summation Register 2.** This is the most significant byte of the lowest 24 bits of the summation register or bits 16-23.

bits 7-0

**Summation Register 3 (SUMR3)**

|                     | 7 | 6 | 5 | 4 | 3 | 2 | 1 | 0 | Reset Value     |
|---------------------|---|---|---|---|---|---|---|---|-----------------|
| SFR E5 <sub>H</sub> |   |   |   |   |   |   |   |   | 00 <sub>H</sub> |

**SUMR3 Summation Register 3.** This is the most significant byte of the 32-bit summation register or bits 24-31.

bits 7-0

**Offset DAC Register (ODAC)**

|                     | 7 | 6 | 5 | 4 | 3 | 2 | 1 | 0 | Reset Value     |
|---------------------|---|---|---|---|---|---|---|---|-----------------|
| SFR E6 <sub>H</sub> |   |   |   |   |   |   |   |   | 00 <sub>H</sub> |

**ODAC Offset DAC Register.** This register will shift the input by up to half of the ADC input range. The least significant bit is equal to the input voltage range divided by 256. The input range will depend on the setting of the PGA. The ODAC is a signed magnitude register with bit 7 providing the sign of the offset and bits 6-0 providing the magnitude.

bit 7 Offset DAC Sign bit.

0 = Positive

1 = Negative

$$\text{bit 6-0 Offset} = \frac{V_{\text{REF}}}{2 \cdot \text{PGA}} \cdot \left( \frac{\text{ODAC}[6:0]}{127} \right) \cdot (-1)^{\text{bit 7}}$$

NOTE: The offset must be used after calibration or the calibration will nullify the effects.

## Low Voltage Detect Control (LVDCON)

|                     | 7      | 6     | 5     | 4     | 3      | 2     | 1     | 0     | Reset Value     |
|---------------------|--------|-------|-------|-------|--------|-------|-------|-------|-----------------|
| SFR E7 <sub>H</sub> | ALVDIS | ALVD2 | ALVD1 | ALVD0 | DLVDIS | DLVD2 | DLVD1 | DLVD0 | 00 <sub>H</sub> |

**ALVDIS** **Analog Low Voltage Detect Disable.**  
 bit 7  
 0 = Enable Detection of Low Analog Supply Voltage.  
 1 = Disable Detection of Low Analog Supply Voltage.

**ALVD2-0** **Analog Voltage Detection Level.**  
 bits 6-4

| ALVD2 | ALVD1 | ALVD0 | VOLTAGE LEVEL                          |
|-------|-------|-------|--|
| 0     | 0     | 0     | AV <sub>DD</sub> 2.7V (default)        |
| 0     | 0     | 1     | AV <sub>DD</sub> 3.0V                  |
| 0     | 1     | 0     | AV <sub>DD</sub> 3.3V                  |
| 0     | 1     | 1     | AV <sub>DD</sub> 4.0V                  |
| 1     | 0     | 0     | AV <sub>DD</sub> 4.2V                  |
| 1     | 0     | 1     | AV <sub>DD</sub> 4.5V                  |
| 1     | 1     | 0     | AV <sub>DD</sub> 4.7V                  |
| 1     | 1     | 1     | External Voltage AIN7 Compared to 1.2V |

**DLVDIS** **Digital Low Voltage Detect Disable.**  
 bit 3  
 0 = Enable Detection of Low Digital Supply Voltage.  
 1 = Disable Detection of Low Digital Supply Voltage.

**DLVD2-0** **Digital Voltage Detection Level.**  
 bits 2-0

| DLVD2 | DLVD1 | DLVD0 | VOLTAGE LEVEL                          |
|-------|-------|-------|--|
| 0     | 0     | 0     | DV <sub>DD</sub> 2.7V (default)        |
| 0     | 0     | 1     | DV <sub>DD</sub> 3.0V                  |
| 0     | 1     | 0     | DV <sub>DD</sub> 3.3V                  |
| 0     | 1     | 1     | DV <sub>DD</sub> 4.0V                  |
| 1     | 0     | 0     | DV <sub>DD</sub> 4.2V                  |
| 1     | 0     | 1     | DV <sub>DD</sub> 4.5V                  |
| 1     | 1     | 0     | DV <sub>DD</sub> 4.7V                  |
| 1     | 1     | 1     | External Voltage AIN6 Compared to 1.2V |

## Extended Interrupt Enable (EIE)

|                     | 7 | 6 | 5 | 4    | 3   | 2   | 1   | 0   | Reset Value     |
|---------------------|---|---|---|------|-----|-----|-----|-----|-----------------|
| SFR E8 <sub>H</sub> | 1 | 1 | 1 | EWDI | EX5 | EX4 | EX3 | EX2 | E0 <sub>H</sub> |

**EWDI** **Enable Watchdog Interrupt.** This bit enables/disables the watchdog interrupt. The Watchdog timer is enabled by the WDTCON (SFR FF<sub>H</sub>) and PDCON (SFR F1<sub>H</sub>) registers.  
 bit 4  
 0 = Disable the Watchdog Interrupt  
 1 = Enable Interrupt Request Generated by the Watchdog Timer

**EX5** **External Interrupt 5 Enable.** This bit enables/disables external interrupt 5.  
 bit 3  
 0 = Disable External Interrupt 5  
 1 = Enable External Interrupt 5

**EX4** **External Interrupt 4 Enable.** This bit enables/disables external interrupt 4.  
 bit 2  
 0 = Disable External Interrupt 4  
 1 = Enable External Interrupt 4

**EX3** **External Interrupt 3 Enable.** This bit enables/disables external interrupt 3.  
 bit 1  
 0 = Disable External Interrupt 3  
 1 = Enable External Interrupt 3

**EX2** **External Interrupt 2 Enable.** This bit enables/disables external interrupt 2.  
 bit 0  
 0 = Disable External Interrupt 2  
 1 = Enable External Interrupt 2

## Hardware Product Code Register 0 (HWPC0)

|                     | 7       | 6       | 5       | 4       | 3       | 2 | 1           | 0 | Reset Value             |
|---------------------|---------|---------|---------|---------|---------|---|-------------|---|-------------------------|
| SFR E9 <sub>H</sub> | HWPC0.7 | HWPC0.6 | HWPC0.5 | HWPC0.4 | HWPC0.3 | 1 | MEMORY SIZE |   | 0000_001xx <sub>B</sub> |

**HWPC0.7-0**      **Hardware Product Code LSB.** Read only.  
bits 7-0

| MEMORY SIZE |   | MODEL     | FLASH MEMORY |
|-------------|---|-----------|--------------|
| 0           | 0 | MSC1212Y2 | 4kB          |
| 0           | 1 | MSC1212Y3 | 8kB          |
| 1           | 0 | MSC1212Y4 | 16kB         |
| 1           | 1 | MSC1212Y5 | 32kB         |

## Hardware Product Code Register 1 (HWPC1)

|                     | 7 | 6 | 5 | 4 | 3 | 2 | 1 | 0 | Reset Value     |
|---------------------|---|---|---|---|---|---|---|---|-----------------|
| SFR EA <sub>H</sub> |   |   |   |   | 1 |   |   |   | 08 <sub>H</sub> |

**HWPC1.7-0**      **Hardware Product Code MSB.** Read only.  
bits 7-0

## Hardware Version Register (HDWVER)

|                     | 7 | 6 | 5 | 4 | 3 | 2 | 1 | 0 | Reset Value |
|---------------------|---|---|---|---|---|---|---|---|-------------|
| SFR EB <sub>H</sub> |   |   |   |   |   |   |   |   |             |

## Flash Memory Control (FMCON)

|                     | 7 | 6     | 5 | 4    | 3 | 2    | 1 | 0 | Reset Value     |
|---------------------|---|-------|---|------|---|------|---|---|-----------------|
| SFR EE <sub>H</sub> | 0 | PGERA | 0 | FRCM | 0 | BUSY | 1 | 0 | 02 <sub>H</sub> |

**PGERA**      **Page Erase.** Available in both user and program modes.

bit 6      0 = Disable Page Erase Mode  
            1 = Enable Page Erase Mode

**FRCM**      **Frequency Control Mode.** The bypass is only used for slow clocks to save power.

bit 4      0 = Bypass (default)  
            1 = Use Delay Line. Saves power (Recommended).

**BUSY**      **Write/Erase BUSY Signal.**

bit 2      0 = Idle or Available  
            1 = Busy

## Flash Memory Timing Control Register (FTCON)

|                     | 7    | 6    | 5    | 4    | 3    | 2    | 1    | 0    | Reset Value     |
|---------------------|------|------|------|------|------|------|------|------|-----------------|
| SFR EF <sub>H</sub> | FER3 | FER2 | FER1 | FER0 | FWR3 | FWR2 | FWR1 | FWR0 | A5 <sub>H</sub> |

Refer to Flash Timing Characteristics

**FER3-0**      **Set Erase.** Flash Erase Time = (1 + FER) • (MSEC + 1) • t<sub>CLK</sub>.

bits 7-4      11ms industrial temperature range.  
                5ms commercial temperature range.

**FWR3-0**      **Set Write.** Flash Write Time = (1 + FWR) • (USEC + 1) • 5 • t<sub>CLK</sub>.

bits 3-0      30µs to 40µs.

## B Register (B)

|                     | 7   | 6   | 5   | 4   | 3   | 2   | 1   | 0   | Reset Value     |
|---------------------|-----|-----|-----|-----|-----|-----|-----|-----|-----------------|
| SFR F0 <sub>H</sub> | B.7 | B.6 | B.5 | B.4 | B.3 | B.2 | B.1 | B.0 | 00 <sub>H</sub> |

**B.7-0 B Register.** This register serves as a second accumulator for certain arithmetic operations. bits 7-0

## Power-Down Control Register (PDCON)

|                     | 7 | 6     | 5 | 4     | 3    | 2     | 1    | 0     | Reset Value     |
|---------------------|---|-------|---|-------|------|-------|------|-------|-----------------|
| SFR F1 <sub>H</sub> | 0 | PDDAC | 1 | PDPWM | PDAD | PDWDT | PDST | PDSPi | 7F <sub>H</sub> |

Turning peripheral modules off puts the MSC1212 in the lowest power mode.

### **PDDAC Pulse Width Module Control.**

bit 6 0 = DACs On  
1 = DACs Power Down

### **PDPWM Pulse Width Module Control.**

bit 4 0 = PWM On  
1 = PWM Power Down

### **PDAD ADC Control.**

bit 3 0 = ADC On  
1 = ADC, V<sub>REF</sub>, Summation registers, and Analog Brownout are powered down. Analog current = 0.

### **PDWDT Watchdog Timer Control.**

bit 2 0 = Watchdog Timer On  
1 = Watchdog Timer Power Down

### **PDST System Timer Control.**

bit 1 0 = System Timer On  
1 = System Timer Power Down

### **PDSPi SPI System Control.**

bit 0 0 = SPI System On  
1 = SPI System Power Down

## PSEN/ALE Select (PASEL)

|                     | 7 | 6 | 5     | 4     | 3     | 2 | 1    | 0    | Reset Value     |
|---------------------|---|---|-------|-------|-------|---|------|------|-----------------|
| SFR F2 <sub>H</sub> | 0 | 0 | PSEN2 | PSEN1 | PSEN0 | 0 | ALE1 | ALE0 | 00 <sub>H</sub> |

### **PSEN2-0 PSEN Mode Select.**

bits 5-3

| PSEN2 | PSEN1 | PSEN0 |                          |
|-------|-------|-------|--------------------------|
| 0     | 0     | X     | $\overline{\text{PSEN}}$ |
| 0     | 1     | X     | CLK                      |
| 1     | 0     | X     | ADC MODCLK               |
| 1     | 1     | 0     | LOW                      |
| 1     | 1     | 1     | HIGH                     |

### **ALE1-0 ALE Mode Select.**

bits 1-0

| ALE1 | ALE0 |      |
|------|------|------|
| 0    | X    | ALE  |
| 1    | 0    | LOW  |
| 1    | 1    | HIGH |

## Analog Clock (ACLK)

|                     | 7 | 6     | 5     | 4     | 3     | 2     | 1     | 0     | Reset Value     |
|---------------------|---|-------|-------|-------|-------|-------|-------|-------|-----------------|
| SFR F6 <sub>H</sub> | 0 | FREQ6 | FREQ5 | FREQ4 | FREQ3 | FREQ2 | FREQ1 | FREQ0 | 03 <sub>H</sub> |

**FREQ6-0 Clock Frequency** – 1. This value + 1 divides the system clock to create the ADC clock.

bits 6-0  
 $ACLK\ frequency = f_{CLK}/(FREQ + 1)$   
 $f_{MOD} = f_{CLK}/(FREQ + 1)/64$   
 Data Rate =  $f_{MOD}/Decimation$

## System Reset Register (SRST)

|                     | 7 | 6 | 5 | 4 | 3 | 2 | 1 | 0      | Reset Value     |
|---------------------|---|---|---|---|---|---|---|--------|-----------------|
| SFR F7 <sub>H</sub> | 0 | 0 | 0 | 0 | 0 | 0 | 0 | RSTREQ | 00 <sub>H</sub> |

**RSTREQ Reset Request.** Setting this bit to 1 and then clearing to 0 will generate a system reset.

bit 0

## Extended Interrupt Priority (EIP)

|                     | 7 | 6 | 5 | 4    | 3   | 2   | 1   | 0   | Reset Value     |
|---------------------|---|---|---|------|-----|-----|-----|-----|-----------------|
| SFR F8 <sub>H</sub> | 1 | 1 | 1 | PWDI | PX5 | PX4 | PX3 | PX2 | E0 <sub>H</sub> |

**PWDI Watchdog Interrupt Priority.** This bit controls the priority of the watchdog interrupt.

bit 4  
 0 = The watchdog interrupt is low priority.  
 1 = The watchdog interrupt is high priority.

**PX5 External Interrupt 5 Priority.** This bit controls the priority of external interrupt 5.

bit 3  
 0 = External interrupt 5 is low priority.  
 1 = External interrupt 5 is high priority.

**PX4 External Interrupt 4 Priority.** This bit controls the priority of external interrupt 4.

bit 2  
 0 = External interrupt 4 is low priority.  
 1 = External interrupt 4 is high priority.

**PX3 External Interrupt 3 Priority.** This bit controls the priority of external interrupt 3.

bit 1  
 0 = External interrupt 3 is low priority.  
 1 = External interrupt 3 is high priority.

**PX2 External Interrupt 2 Priority.** This bit controls the priority of external interrupt 2.

bit 0  
 0 = External interrupt 2 is low priority.  
 1 = External interrupt 2 is high priority.

## Seconds Timer Interrupt (SECINT)

|                     | 7   | 6       | 5       | 4       | 3       | 2       | 1       | 0       | Reset Value     |
|---------------------|-----|---------|---------|---------|---------|---------|---------|---------|-----------------|
| SFR F9 <sub>H</sub> | WRT | SECINT6 | SECINT5 | SECINT4 | SECINT3 | SECINT2 | SECINT1 | SECINT0 | 7F <sub>H</sub> |

This system clock is divided by the value of the 16-bit register MSECH:MSECL. Then that 1ms timer tick is divided by the register HMSEC which provides the 100ms signal used by this seconds timer. Therefore, this seconds timer can generate an interrupt which occurs from 100ms to 12.8 seconds. Reading this register will clear the Seconds Interrupt. This Interrupt can be monitored in the AIE register.

**WRT Write Control.** Determines whether to write the value immediately or wait until the current count is finished.

bit 7  
 Read = 0.  
 0 = Delay Write Operation. The SEC value is loaded when the current count expires.  
 1 = Write Immediately. The counter is loaded once the CPU completes the write operation.

**SECINT6-0 Seconds Count.** Normal operation would use 100ms as the clock interval.

bits 6-0  
 $Seconds\ Interrupt = (1 + SEC) \cdot (HMSEC + 1) \cdot (MSEC + 1) \cdot t_{CLK}$ .

### Milliseconds Interrupt (MSINT)

|                     | 7   | 6      | 5      | 4      | 3      | 2      | 1      | 0      | Reset Value     |
|---------------------|-----|--------|--------|--------|--------|--------|--------|--------|-----------------|
| SFR FA <sub>H</sub> | WRT | MSINT6 | MSINT5 | MSINT4 | MSINT3 | MSINT2 | MSINT1 | MSINT0 | 7F <sub>H</sub> |

The clock used for this timer is the 1ms clock which results from dividing the system clock by the values in registers MSEC:MSECL. Reading this register will clear the interrupt.

**WRT** **Write Control.** Determines whether to write the value immediately or wait until the current count is finished. Read = 0.  
 bit 7 0 = Delay Write Operation. The MSINT value is loaded when the current count expires.  
 1 = Write Immediately. The MSINT counter is loaded once the CPU completes the write operation.

**MSINT6-0** **Seconds Count.** Normal operation would use 1ms as the clock interval.  
 bits 6-0 MS Interrupt Interval = (1 + MSINT) • (MSEC + 1) • t<sub>CLK</sub>

### One Microsecond Register (USEC)

|                     | 7 | 6 | 5 | 4     | 3     | 2     | 1     | 0     | Reset Value     |
|---------------------|---|---|---|-------|-------|-------|-------|-------|-----------------|
| SFR FB <sub>H</sub> | 0 | 0 | 0 | FREQ4 | FREQ3 | FREQ2 | FREQ1 | FREQ0 | 03 <sub>H</sub> |

**FREQ4-0** **Clock Frequency – 1.** This value + 1 divides the system clock to create a 1µs Clock.  
 bits 4-0 USEC = CLK/(FREQ + 1). This clock is used to set Flash write time. See FTCON (SFR EF<sub>H</sub>).

### One Millisecond Low Register (MSECL)

|                     | 7      | 6      | 5      | 4      | 3      | 2      | 1      | 0      | Reset Value     |
|---------------------|--------|--------|--------|--------|--------|--------|--------|--------|-----------------|
| SFR FC <sub>H</sub> | MSECL7 | MSECL6 | MSECL5 | MSECL4 | MSECL3 | MSECL2 | MSECL1 | MSECL0 | 9F <sub>H</sub> |

**MSECL7-0** **One Millisecond Low.** This value in combination with the next register is used to create a 1ms Clock.  
 bits 7-0 1ms Clock = (MSECH • 256 + MSECL + 1) • t<sub>CLK</sub>. This clock is used to set Flash erase time. See FTCON (SFR EF<sub>H</sub>).

### One Millisecond High Register (MSECH)

|                     | 7      | 6      | 5      | 4      | 3      | 2      | 1      | 0      | Reset Value     |
|---------------------|--------|--------|--------|--------|--------|--------|--------|--------|-----------------|
| SFR FD <sub>H</sub> | MSECH7 | MSECH6 | MSECH5 | MSECH4 | MSECH3 | MSECH2 | MSECH1 | MSECH0 | 0F <sub>H</sub> |

**MSECH7-0** **One Millisecond High.** This value in combination with the previous register is used to create a 1ms clock.  
 bits 7-0 1ms = (MSECH • 256 + MSECL + 1) • t<sub>CLK</sub>.

### One Hundred Millisecond Register (HMSEC)

|                     | 7      | 6      | 5      | 4      | 3      | 2      | 1      | 0      | Reset Value     |
|---------------------|--------|--------|--------|--------|--------|--------|--------|--------|-----------------|
| SFR FE <sub>H</sub> | HMSEC7 | HMSEC6 | HMSEC5 | HMSEC4 | HMSEC3 | HMSEC2 | HMSEC1 | HMSEC0 | 63 <sub>H</sub> |

**HMSEC7-0** **One Hundred Millisecond.** This clock divides the 1ms clock to create a 100ms clock.  
 bits 7-0 100ms = (MSECH • 256 + MSECL + 1) • (HMSEC + 1) • t<sub>CLK</sub>.

### Watchdog Timer Register (WDTCON)

|                     | 7    | 6    | 5    | 4      | 3      | 2      | 1      | 0      | Reset Value     |
|---------------------|------|------|------|--------|--------|--------|--------|--------|-----------------|
| SFR FF <sub>H</sub> | EWDT | DWDT | RWDT | WDCNT4 | WDCNT3 | WDCNT2 | WDCNT1 | WDCNT0 | 00 <sub>H</sub> |

**EWDT** **Enable Watchdog (R/W).**  
 bit 7 Write 1/Write 0 sequence sets the Watchdog Enable Counting bit.

**DWDT** **Disable Watchdog (R/W).**  
 bit 6 Write 1/Write 0 sequence clears the Watchdog Enable Counting bit.

**RWDT** **Reset Watchdog (R/W).**  
 bit 5 Write 1/Write 0 sequence restarts the Watchdog Counter.

**WDCNT4-0** **Watchdog Count (R/W).**  
 bits 4-0 Watchdog expires in (WDCNT + 1) • HMSEC to (WDCNT + 2) • HMSEC, if the sequence is not asserted. There is an uncertainty of 1 count.

PAG (S-PQFP-G64)

PLASTIC QUAD FLATPACK

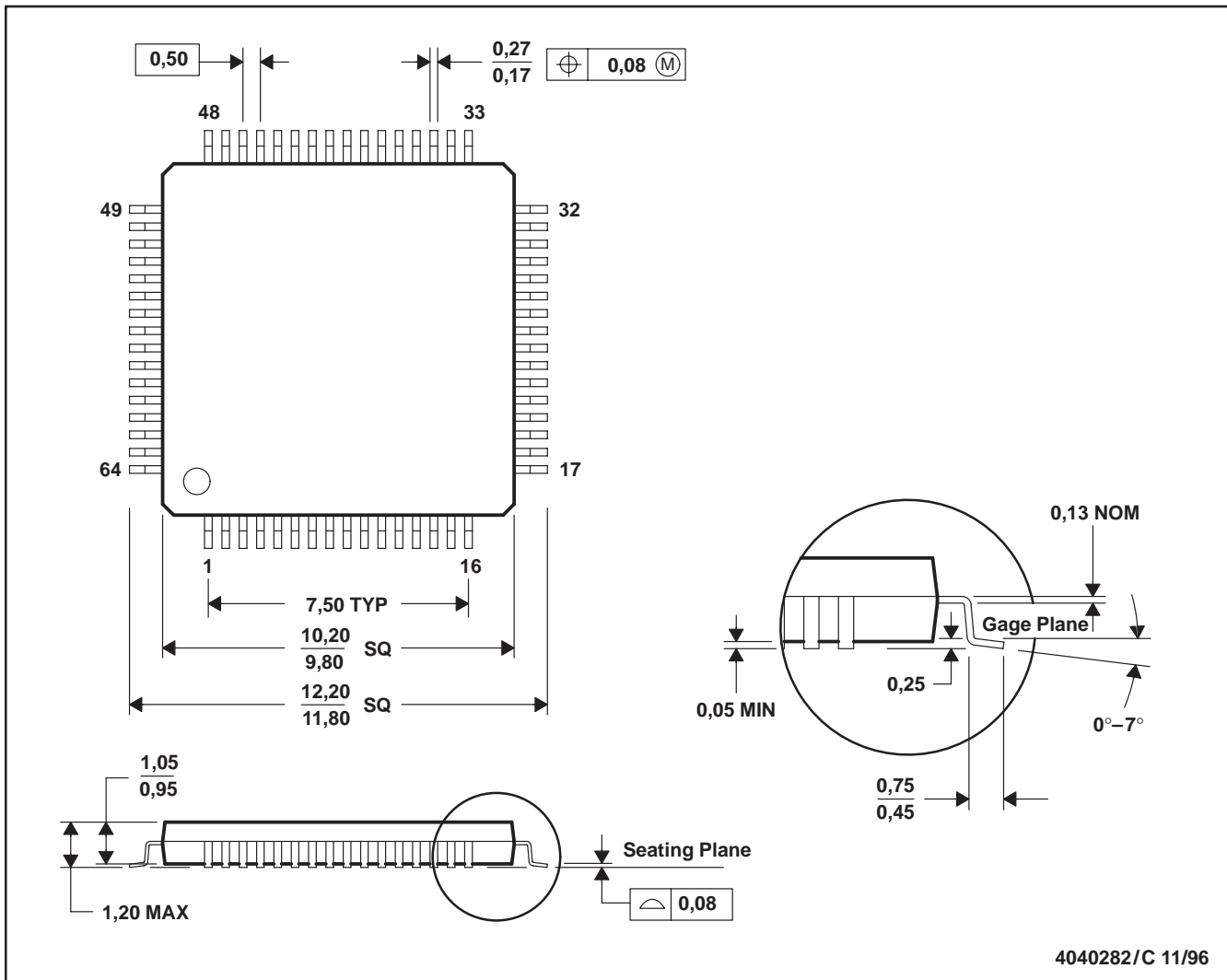

4040282/C 11/96

- NOTES: A. All linear dimensions are in millimeters.  
 B. This drawing is subject to change without notice.  
 C. Falls within JEDEC MS-026

## IMPORTANT NOTICE

Texas Instruments Incorporated and its subsidiaries (TI) reserve the right to make corrections, modifications, enhancements, improvements, and other changes to its products and services at any time and to discontinue any product or service without notice. Customers should obtain the latest relevant information before placing orders and should verify that such information is current and complete. All products are sold subject to TI's terms and conditions of sale supplied at the time of order acknowledgment.

TI warrants performance of its hardware products to the specifications applicable at the time of sale in accordance with TI's standard warranty. Testing and other quality control techniques are used to the extent TI deems necessary to support this warranty. Except where mandated by government requirements, testing of all parameters of each product is not necessarily performed.

TI assumes no liability for applications assistance or customer product design. Customers are responsible for their products and applications using TI components. To minimize the risks associated with customer products and applications, customers should provide adequate design and operating safeguards.

TI does not warrant or represent that any license, either express or implied, is granted under any TI patent right, copyright, mask work right, or other TI intellectual property right relating to any combination, machine, or process in which TI products or services are used. Information published by TI regarding third-party products or services does not constitute a license from TI to use such products or services or a warranty or endorsement thereof. Use of such information may require a license from a third party under the patents or other intellectual property of the third party, or a license from TI under the patents or other intellectual property of TI.

Reproduction of information in TI data books or data sheets is permissible only if reproduction is without alteration and is accompanied by all associated warranties, conditions, limitations, and notices. Reproduction of this information with alteration is an unfair and deceptive business practice. TI is not responsible or liable for such altered documentation.

Resale of TI products or services with statements different from or beyond the parameters stated by TI for that product or service voids all express and any implied warranties for the associated TI product or service and is an unfair and deceptive business practice. TI is not responsible or liable for any such statements.

### Mailing Address:

Texas Instruments  
Post Office Box 655303  
Dallas, Texas 75265