

ANALOG PERIPHERALS

Comparator

- Programmable Hysteresis and Response Time
- Configurable as Wake-up or Reset Source
- Low Current (0.4uA)

ON-CHIP DEBUG

- On-Chip Debug Circuitry Facilitates Full Speed, Non-Intrusive In-System Debug (No Emulator Required!)
- Provides Breakpoints, Single Stepping, Watchpoints
- Inspect/Modify Memory, Registers, and Stack
- Superior Performance to Emulation Systems Using ICE-Chips, Target Pods, and Sockets
- Low Cost, **Complete** Development Kit

SUPPLY VOLTAGE 2.7V to 3.6V

- Typical Operating Current: 6.4mA @ 25MHz
9uA @ 32kHz
- Typical Stop Mode Current: <0.1uA

Temperature Range: -40°C to +85°C

20-Pin Micro Lead Package

- 4 x 4mm PCB Footprint

HIGH SPEED 8051 μ C Core

- Pipelined Instruction Architecture; Executes 70% of Instructions in 1 or 2 System Clocks
- Up to 25MIPS Throughput with 25MHz Clock
- Expanded Interrupt Handler

MEMORY

- 768 Bytes Internal Data RAM (256 + 512 XRAM)
- 8k Bytes FLASH; In-System Programmable in 512 byte Sectors

DIGITAL PERIPHERALS

- 17 Port I/O; All 5V tolerant with High Sink Current
- Enhanced Hardware UART, SPI™, and SMBus™ Serial Ports
- Four General Purpose 16-Bit Counter/Timers
- 16-bit Programmable Counter Array with Three Capture/Compare Modules, WDT
- Real Time Clock Mode using PCA or Timer and External Clock Source

CLOCK SOURCES

- Two Internal Oscillators:
25MHz, 2% Accuracy Supports UART Operation
80kHz Low Frequency, Low-power
- External Oscillator:
Crystal, RC, C, or Clock (1 or 2 Pin Modes)
- Can Switch Between Clock Sources on-the-fly; Useful in Power Saving Modes

SMBus is a trademark of Intel Corp.; SPI is a trademark of Motorola, Inc.

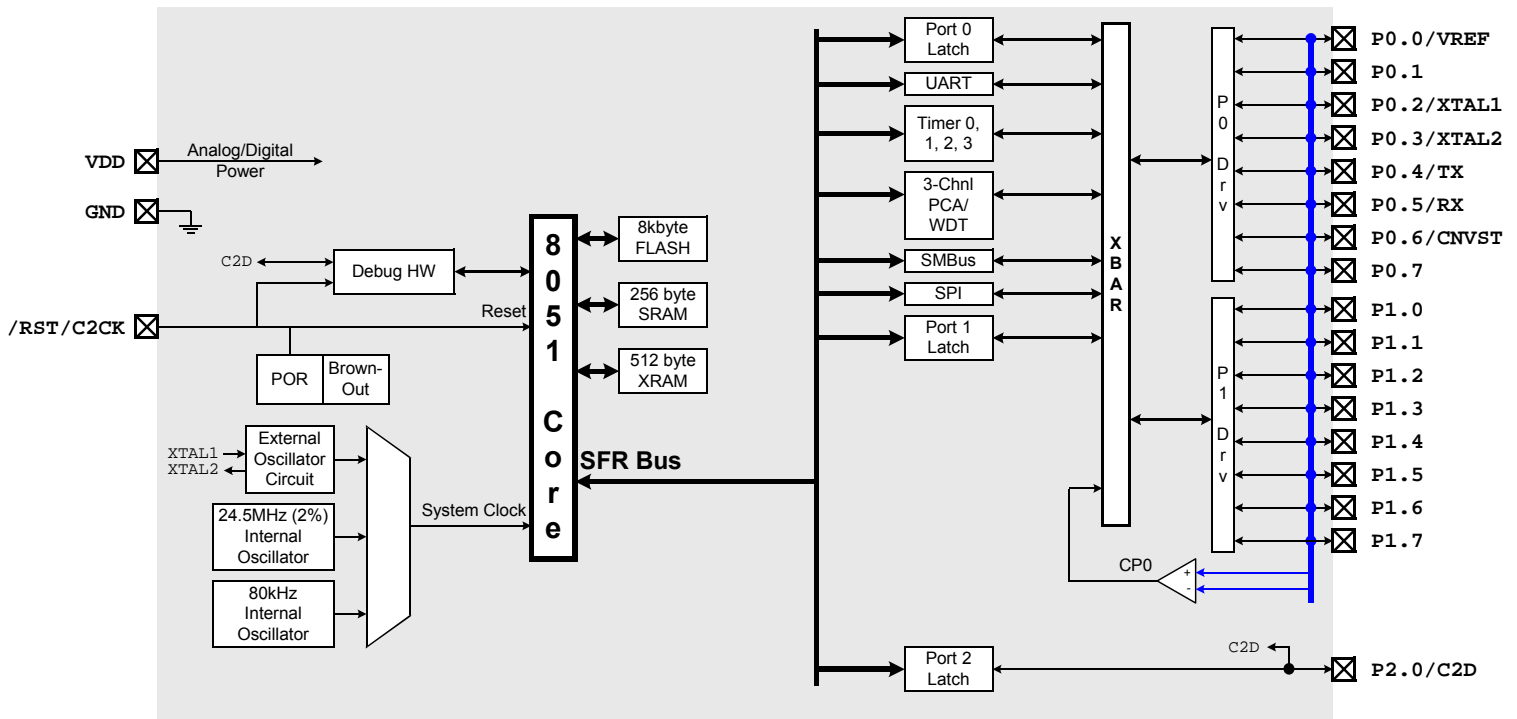

SELECTED ELECTRICAL SPECIFICATIONS $T_A = -40^{\circ}\text{C}$ to $+85^{\circ}\text{C}$, $V_{DD} = 2.7\text{V}$ unless otherwise specified.

PARAMETER	CONDITIONS	MIN	TYP	MAX	UNITS
GLOBAL CHARACTERISTICS					
Supply Voltage		2.7		3.6	V
Supply Current with CPU active	Clock=25MHz		6.4		mA
	Clock=1MHz		0.36		mA
	Clock=80kHz; VDD Monitor Disabled		20		μA
	Clock=32kHz; VDD Monitor Disabled		9		μA
Supply Current (shutdown)	Oscillator off; VDD Monitor Disabled		<0.1		μA
Clock Frequency Range		DC		25	MHz
INTERNAL OSCILLATORS					
Frequency (OSC0)		24.0	24.5	25.0	MHz
Frequency (OSC1)	Note 1		80		kHz
COMPARATOR					
Response Time Mode0	$(\text{CP}+) - (\text{CP}-) = 100\text{mV}$		0.1		μs
Current Consumption Mode0			7.6		μA
Response Time Mode1	$(\text{CP}+) - (\text{CP}-) = 100\text{mV}$		0.18		μs
Current Consumption Mode1			3.2		μA
Response Time Mode2	$(\text{CP}+) - (\text{CP}-) = 100\text{mV}$		0.32		μs
Current Consumption Mode2			1.3		μA
Response Time Mode3	$(\text{CP}+) - (\text{CP}-) = 100\text{mV}$		1		μs
Current Consumption Mode3			0.4		μA

Note 1: OSC1 can be calibrated in 2.5% steps using an internal calibration register

