



**ARM Cortex™-M0  
32-BIT MICROCONTROLLER**

**NuMicro™ NUC100 Series  
NUC100/NUC120  
Technical Reference Manual**

*The information described in this document is the exclusive intellectual property of Nuvoton Technology Corporation and shall not be reproduced without permission from Nuvoton.*

*Nuvoton is providing this document only for reference purposes of NuMicro microcontroller based system design. Nuvoton assumes no responsibility for errors or omissions.*

*All data and specifications are subject to change without notice.*

*For additional information or questions, please contact: Nuvoton Technology Corporation.*



## Contents

1	GENERAL DESCRIPTION .....	12
2	FEATURES .....	13
2.1	NuMicro™ NUC100 Features – Advanced Line .....	13
2.2	NuMicro™ NUC120 Features – USB Line .....	17
3	PARTS INFORMATION LIST AND PIN CONFIGURATION .....	21
3.1	NuMicro™ NUC100 Products Selection Guide .....	21
3.1.1	NuMicro™ NUC100 Medium Density Advance Line Selection Guide .....	21
3.1.2	NuMicro™ NUC100 Low Density Advance Line Selection Guide .....	21
3.2	NuMicro™ NUC120 Products Selection Guide .....	22
3.2.1	NuMicro™ NUC120 Medium Density USB Line Selection Guide .....	22
3.2.2	NuMicro™ NUC120 Low Density USB Line Selection Guide .....	22
3.3	Pin Configuration .....	24
3.3.1	NuMicro™ NUC100/NUC120 Medium Density Pin Diagram .....	24
3.3.2	NuMicro™ NUC100/NUC120 Low Density Pin Diagram .....	30
3.4	Pin Description .....	34
3.4.1	NuMicro™ NUC100/NUC120 Medium Density Pin Description .....	34
3.4.2	NuMicro™ NUC100/NUC120 Low Density Pin Description .....	48
4	BLOCK DIAGRAM .....	58
4.1	NuMicro™ NUC100/NUC120 Medium Density Block Diagram .....	58
4.1.1	NuMicro™ NUC100 Medium Density Block Diagram .....	58
4.1.2	NuMicro™ NUC120 Medium Density Block Diagram .....	59
4.2	NuMicro™ NUC100/NUC120 Low Density Block Diagram .....	60
4.2.1	NuMicro™ NUC100 Low Density Block Diagram .....	60
4.2.2	NuMicro™ NUC120 Low Density Block Diagram .....	61
5	FUNCTIONAL DESCRIPTION .....	62
5.1	ARM® Cortex™-M0 Core .....	62
5.2	System Manager .....	64
5.2.1	Overview .....	64
5.2.2	System Reset .....	64
5.2.3	System Power Distribution .....	65
5.2.4	System Memory Map .....	67
5.2.5	System Manager Control Registers .....	69
5.2.6	System Timer (SysTick) .....	104
5.2.7	Nested Vectored Interrupt Controller (NVIC) .....	109
5.2.8	System Control Register .....	133
5.3	Clock Controller .....	141
5.3.1	Overview .....	141
5.3.2	Clock Generator .....	143
5.3.3	System Clock and SysTick Clock .....	144



5.3.4	Peripherals Clock .....	145
5.3.5	Power Down Mode Clock .....	145
5.3.6	Frequency Divider Output.....	146
5.3.7	Register Map .....	147
5.3.8	Register Description .....	148
5.4	USB Device Controller (USB) .....	166
5.4.1	Overview .....	166
5.4.2	Features .....	166
5.4.3	Block Diagram .....	167
5.4.4	Function Description.....	168
5.4.5	Register and Memory Map .....	172
5.4.6	Register Description .....	174
5.5	General Purpose I/O (GPIO) .....	190
5.5.1	Overview .....	190
5.5.2	Features .....	190
5.5.3	Function Description.....	191
5.5.4	Register Map .....	194
5.5.5	Register Description .....	200
5.6	I <sup>2</sup> C Serial Interface Controller (Master/Slave) (I <sup>2</sup> C) .....	213
5.6.1	Overview .....	213
5.6.2	Features .....	214
5.6.3	Function Description.....	215
5.6.4	Protocol Registers .....	218
5.6.5	Register Map .....	222
5.6.6	Register Description .....	223
5.6.7	Modes of Operation .....	231
5.7	PWM Generator and Capture Timer (PWM) .....	237
5.7.1	Overview .....	237
5.7.2	Features .....	238
5.7.3	Block Diagram .....	239
5.7.4	Function Description.....	243
5.7.5	Register Map .....	251
5.7.6	Register Description .....	254
5.8	Real Time Clock (RTC).....	276
5.8.1	Overview .....	276
5.8.2	Features .....	276
5.8.3	Block Diagram .....	277
5.8.4	Function Description.....	278
5.8.5	Register Map .....	280
5.8.6	Register Description .....	281
5.9	Serial Peripheral Interface (SPI) .....	294
5.9.1	Overview .....	294
5.9.2	Features .....	294
5.9.3	Block Diagram .....	295
5.9.4	Function Description.....	296



5.9.5	Timing Diagram .....	303
5.9.6	Programming Examples .....	306
5.9.7	Register Map .....	308
5.9.8	Register Description .....	309
5.10	Timer Controller (TMR) .....	319
5.10.1	Overview .....	319
5.10.2	Features .....	319
5.10.3	Block Diagram .....	320
5.10.4	Function Description .....	321
5.10.5	Register Map .....	323
5.10.6	Register Description .....	324
5.11	Watchdog Timer (WDT) .....	329
5.11.1	Overview .....	329
5.11.2	Features .....	331
5.11.3	Block Diagram .....	331
5.11.4	Register Map .....	332
5.11.5	Register Description .....	333
5.12	UART Interface Controller (UART) .....	335
5.12.1	Overview .....	335
5.12.2	Features .....	337
5.12.3	Block Diagram .....	338
5.12.4	IrDA Mode .....	341
5.12.5	RS-485 function mode (NuMicro™ NUC100/NUC120 Low Density Only) .....	343
5.12.6	Register Map .....	345
5.12.7	Register Description .....	347
5.13	PS/2 Device Controller (PS2D) .....	371
5.13.1	Overview .....	371
5.13.2	Features .....	371
5.13.3	Block Diagram .....	372
5.13.4	Functional Description .....	373
5.13.5	Register Map .....	378
5.13.6	Register Description .....	379
5.14	I <sup>2</sup> S Controller (I <sup>2</sup> S) .....	386
5.14.1	Overview .....	386
5.14.2	Features .....	386
5.14.3	Block Diagram .....	387
5.14.4	Functional Description .....	388
5.14.5	Register Map .....	390
5.14.6	Register Description .....	391
5.15	Analog-to-Digital Converter (ADC) .....	402
5.15.1	Overview .....	402
5.15.2	Features .....	402
5.15.3	Block Diagram .....	403
5.15.4	Functional Description .....	404
5.15.5	Register Map .....	410



	5.15.6	Register Description .....	411
5.16		Analog Comparator (CMP) .....	425
	5.16.1	Overview .....	425
	5.16.2	Features .....	425
	5.16.3	Block Diagram .....	425
	5.16.4	Functional Description .....	426
	5.16.5	Register Map .....	427
	5.16.6	Register Description .....	428
5.17		PDMA Controller (PDMA) .....	431
	5.17.1	Overview .....	431
	5.17.2	Features .....	431
	5.17.3	Block Diagram .....	432
	5.17.4	Function Description .....	434
	5.17.5	Register Map .....	435
	5.17.6	Register Description .....	436
5.18		External Bus Interface (EBI) .....	457
	5.18.1	Overview .....	457
	5.18.2	Features .....	457
	5.18.3	Block Diagram .....	458
	5.18.4	Function Description .....	458
	5.18.5	Register Map .....	464
	5.18.6	Register Description .....	464
6		FLASH MEMORY CONTROLLER (FMC) .....	467
	6.1	Overview .....	467
	6.2	Features .....	467
	6.3	Block Diagram .....	468
	6.4	Flash Memory Organization .....	470
	6.5	Boot Selection .....	473
	6.6	Data Flash .....	473
	6.7	User Configuration .....	475
	6.8	In System Program (ISP) .....	478
	6.8.1	ISP Procedure .....	478
	6.9	Flash Control Register Map .....	481
	6.10	Flash Control Register Description .....	482
7		ELECTRICAL CHARACTERISTICS .....	491
	7.1	Absolute Maximum Ratings .....	491
	7.2	DC Electrical Characteristics .....	492
	7.2.1	NuMicro™ NUC100/NUC120 Medium Density DC Electrical Characteristics .....	492
	7.2.2	NuMicro™ NUC100/NUC120 Low Density DC Electrical Characteristics .....	497
	7.2.3	Operating Current Curve (Test condition: run NOP) .....	502
	7.2.4	Idle Current Curve .....	504
	7.2.5	Power Down Current Curve .....	506



7.3	AC Electrical Characteristics .....	507
7.3.1	External 4~24 MHz High Speed Crystal .....	507
7.3.2	External 32.768 kHz Low Speed Crystal .....	508
7.3.3	Internal 22.1184 MHz High Speed Oscillator.....	508
7.3.4	Internal 10 kHz Low Speed Oscillator.....	508
7.4	Analog Characteristics .....	510
7.4.1	Specification of 12-bit SARADC .....	510
7.4.2	Specification of LDO and Power management.....	511
7.4.3	Specification of Low Voltage Reset .....	512
7.4.4	Specification of Brown-Out Detector.....	512
7.4.5	Specification of Power-On Reset (5 V).....	512
7.4.6	Specification of Temperature Sensor .....	513
7.4.7	Specification of Comparator .....	513
7.4.8	Specification of USB PHY .....	514
7.5	Flash DC Electrical Characteristics .....	515
7.6	SPI Dynamic Characteristics .....	516
8	PACKAGE DIMENSIONS .....	518
8.1	100L LQFP (14x14x1.4 mm footprint 2.0mm) .....	518
8.2	64L LQFP (10x10x1.4mm footprint 2.0 mm) .....	519
8.3	48L LQFP (7x7x1.4mm footprint 2.0mm) .....	520
9	REVISION HISTORY .....	521

## Figures

Figure 3-1 NuMicro™ NUC100 Series selection code .....	23
Figure 3-2 NuMicro™ NUC100 Medium Density LQFP 100-pin Pin Diagram .....	24
Figure 3-3 NuMicro™ NUC100 Medium Density LQFP 64-pin Pin Diagram .....	25
Figure 3-4 NuMicro™ NUC100 Medium Density LQFP 48-pin Pin Diagram .....	26
Figure 3-5 NuMicro™ NUC120 Medium Density LQFP 100-pin Pin Diagram .....	27
Figure 3-6 NuMicro™ NUC120 Medium Density LQFP 64-pin Pin Diagram .....	28
Figure 3-7 NuMicro™ NUC120 Medium Density LQFP 48-pin Pin Diagram .....	29
Figure 3-8 NuMicro™ NUC100 Low Density LQFP 64-pin Pin Diagram.....	30
Figure 3-9 NuMicro™ NUC100 Low Density LQFP 48-pin Pin Diagram.....	31
Figure 3-10 NuMicro™ NUC120 Low Density LQFP 64-pin Pin Diagram.....	32
Figure 3-11 NuMicro™ NUC120 Low Density LQFP 48-pin Pin Diagram.....	33
Figure 4-1 NuMicro™ NUC100 Medium Density Block Diagram .....	58
Figure 4-2 NuMicro™ NUC120 Medium Density Block Diagram .....	59
Figure 4-3 NuMicro™ NUC100 Low Density Block Diagram .....	60
Figure 4-4 NuMicro™ NUC120 Low Density Block Diagram .....	61
Figure 5-1 Functional Controller Diagram .....	62
Figure 5-2 NuMicro™ NUC120 Power Distribution Diagram.....	65
Figure 5-3 NuMicro™ NUC100 Power Distribution Diagram.....	66
Figure 5-4 Clock generator global view diagram .....	142
Figure 5-5 Clock generator block diagram.....	143
Figure 5-6 System Clock Block Diagram .....	144
Figure 5-7 SysTick Clock Control Block Diagram .....	144
Figure 5-8 Clock Source of Frequency Divider .....	146
Figure 5-9 Block Diagram of Frequency Divider .....	146
Figure 5-10 USB Block Diagram .....	167
Figure 5-11 Wake-up Interrupt Operation Flow .....	169
Figure 5-12 Endpoint SRAM Structure .....	170
Figure 5-13 Setup Transaction followed by Data in Transaction .....	171
Figure 5-14 Data Out Transfer .....	172
Figure 5-15 Push-Pull Output.....	191
Figure 5-16 Open-Drain Output .....	192
Figure 5-17 Quasi-bidirectional I/O Mode .....	192

Figure 5-18 I <sup>2</sup> C Bus Timing .....	213
Figure 5-19 I <sup>2</sup> C Protocol.....	215
Figure 5-20 Master Transmits Data to Slave .....	215
Figure 5-21 Master Reads Data from Slave .....	216
Figure 5-22 START and STOP condition.....	216
Figure 5-23 Bit Transfer on the I <sup>2</sup> C bus .....	217
Figure 5-24 Acknowledge on the I <sup>2</sup> C bus.....	217
Figure 5-25 I <sup>2</sup> C Data Shifting Direction .....	219
Figure 5-26: I <sup>2</sup> C Time-out Count Block Diagram .....	221
Figure 5-27 Legend for the following five figures .....	231
Figure 5-28 Master Transmitter Mode .....	232
Figure 5-29 Master Receiver Mode.....	233
Figure 5-30 Slave Receiver Mode.....	234
Figure 5-31 Slave Transmitter Mode.....	235
Figure 5-32 GC Mode .....	236
Figure 5-33 PWM Generator 0 Clock Source Control.....	239
Figure 5-34 PWM Generator 0 Architecture Diagram.....	239
Figure 5-35 PWM Generator 2 Clock Source Control.....	240
Figure 5-36 PWM Generator 2 Architecture Diagram.....	240
Figure 5-37 PWM Generator 4 Clock Source Control.....	241
Figure 5-38 PWM Generator 4 Architecture Diagram.....	241
Figure 5-39 PWM Generator 6 Clock Source Control.....	242
Figure 5-40 PWM Generator 6 Architecture Diagram.....	242
Figure 5-41 Legend of Internal Comparator Output of PWM-Timer .....	243
Figure 5-42 PWM-Timer Operation Timing .....	244
Figure 5-43 PWM Double Buffering Illustration.....	245
Figure 5-44 PWM Controller Output Duty Ratio.....	246
Figure 5-45 Paired-PWM Output with Dead Zone Generation Operation .....	246
Figure 5-46 Capture Operation Timing .....	247
Figure 5-47 PWM Group A PWM-Timer Interrupt Architecture Diagram.....	248
Figure 5-48 PWM Group B PWM-Timer Interrupt Architecture Diagram.....	248
Figure 5-49 RTC Block Diagram .....	277
Figure 5-50 SPI Block Diagram.....	295
Figure 5-51 SPI Master Mode Application Block Diagram.....	296
Figure 5-52 SPI Slave Mode Application Block Diagram.....	297
Figure 5-53 Variable Serial Clock Frequency .....	298



Figure 5-54 32-Bit in one Transaction.....	298
Figure 5-55 Two Transactions in One Transfer (Burst Mode) .....	299
Figure 5-56 Byte Reorder.....	300
Figure 5-57 Timing Waveform for Byte Suspend.....	301
Figure 5-58 Two Bits Transfer Mode (slave mode).....	302
Figure 5-59 SPI Timing in Master Mode .....	303
Figure 5-60 SPI Timing in Master Mode (Alternate Phase of SPICLK) .....	304
Figure 5-61 SPI Timing in Slave Mode .....	304
Figure 5-62 SPI Timing in Slave Mode (Alternate Phase of SPICLK) .....	305
Figure 5-63 Timer Controller Block Diagram .....	320
Figure 5-64 Clock Source of Timer Controller .....	320
Figure 5-65 Continuous Counting Mode .....	322
Figure 5-66 Timing of Interrupt and Reset Signal .....	330
Figure 5-67 Watchdog Timer Clock Control.....	331
Figure 5-68 Watchdog Timer Block Diagram.....	331
Figure 5-69 UART Clock Control Diagram.....	338
Figure 5-70 UART Block Diagram.....	338
Figure 5-71 Auto Flow Control Block Diagram.....	340
Figure 5-72 IrDA Block Diagram .....	341
Figure 5-73 IrDA TX/RX Timing Diagram .....	342
Figure 5-74 Structure of RS-485 Frame .....	344
Figure 5-75 PS/2 Device Block Diagram .....	372
Figure 5-76 Data Format of Device-to-Host.....	374
Figure 5-77 Data Format of Host-to-Device.....	374
Figure 5-78 PS/2 Bit Data Format.....	375
Figure 5-79 PS/2 Bus Timing.....	375
Figure 5-80 PS/2 Data Format.....	377
Figure 5-81 I <sup>2</sup> S Clock Control Diagram.....	387
Figure 5-82 I <sup>2</sup> S Controller Block Diagram .....	387
Figure 5-83 I <sup>2</sup> S Bus Timing Diagram (Format =0) .....	388
Figure 5-84 MSB Justified Timing Diagram (Format=1) .....	388
Figure 5-85 FIFO contents for various I <sup>2</sup> S modes .....	389
Figure 5-86 ADC Controller Block Diagram .....	403
Figure 5-87 ADC Converter Self-Calibration Timing Diagram .....	404
Figure 5-88 ADC Clock Control.....	405
Figure 5-89 Single Mode Conversion Timing Diagram.....	405

Figure 5-90 Single-Cycle Scan on Enabled Channels Timing Diagram .....	406
Figure 5-91 Continuous Scan on Enabled Channels Timing Diagram .....	407
Figure 5-92 A/D Conversion Result Monitor Logics Diagram .....	408
Figure 5-93 A/D Controller Interrupt.....	409
Figure 5-94 ADC single-end input conversion voltage and conversion result mapping diagram	413
Figure 5-95 ADC differential input conversion voltage and conversion result mapping diagram	413
Figure 5-96 Analog Comparator Block Diagram .....	425
Figure 5-97 Comparator Controller Interrupt Sources .....	426
Figure 5-98 NuMicro™ NUC100/NUC120 Medium Density PDMA Controller Block Diagram ....	432
Figure 5-99 NuMicro™ NUC100/NUC120 Low Density PDMA Controller Block Diagram .....	433
Figure 5-100 EBI Block Diagram.....	458
Figure 5-101 Connection of 16-bit EBI Data Width with 16-bit Device .....	459
Figure 5-102 Connection of 8-bit EBI Data Width with 8-bit Device .....	459
Figure 5-103 Timing Control Waveform for 16-bit Data Width.....	461
Figure 5-104 Timing Control Waveform for 8-bit Data Width.....	462
Figure 5-105 Timing Control Waveform for Insert Idle Cycle.....	463
Figure 6-1 NuMicro™ NUC100/NUC120 Medium Density Flash Memory Control Block Diagram .....	468
Figure 6-2 NuMicro™ NUC100/NUC120 Low Density Flash Memory Control Block Diagram ....	469
Figure 6-3 NuMicro™ NUC100/NUC120 Medium Density Flash Memory Organization .....	471
Figure 6-4 NuMicro™ NUC100/NUC120 Low Density Flash Memory Organization.....	472
Figure 6-5 NuMicro™ NUC100/NUC120 Medium Density Flash Memory Structure .....	473
Figure 6-6 NuMicro™ NUC100/NUC120 Low Density Flash Memory Structure .....	474
Figure 7-1 Typical Crystal Application Circuit .....	508
Figure 7-2 SPI Master dynamic characteristics timing.....	517
Figure 7-3 SPI Slave dynamic characteristics timing.....	517



**Tables**

Table 1-1 Connectivity Supported Table..... 12

Table 5-1 Address Space Assignments for On-Chip Controllers..... 68

Table 5-2 Exception Model ..... 110

Table 5-3 System Interrupt Map..... 111

Table 5-4 Vector Table Format ..... 112

Table 5-5 Power Down Mode Control Table ..... 150

Table 5-6 I<sup>2</sup>C Status Code Description Table ..... 220

Table 5-7 Byte Order and Byte Suspend Conditions..... 301

Table 5-8 Watchdog Timeout Interval Selection ..... 330

Table 5-9 UART Baud Rate Equation ..... 335

Table 5-10 UART Baud Rate Setting Table ..... 336

Table 5-11 UART Interrupt Sources and Flags Table In DMA Mode ..... 363

Table 5-12 UART Interrupt Sources and Flags Table In Software Mode ..... 363

Table 5-13 Baud rate equation table..... 366

Table 6-1 NuMicro™ NUC100/NUC120 Medium Density Memory Address Map..... 470

Table 6-2 NuMicro™ NUC100/NUC120 Low Density Memory Address Map..... 470

Table 6-3 ISP Mode ..... 480



## 1 GENERAL DESCRIPTION

The NuMicro™ NUC100 Series is 32-bit microcontrollers with embedded ARM® Cortex™-M0 core for industrial control and applications which need rich communication interfaces. The Cortex™-M0 is the newest ARM® embedded processor with 32-bit performance and at a cost equivalent to traditional 8-bit microcontroller. NuMicro™ NUC100 Series includes NUC100, NUC120, NUC130 and NUC140 product line.

The NuMicro™ NUC100 Advanced Line embeds Cortex™-M0 core running up to 50 MHz with 32K/64K/128K-byte embedded flash, 4K/8K/16K-byte embedded SRAM, and 4K-byte loader ROM for the ISP. It also equips with plenty of peripheral devices, such as Timers, Watchdog Timer, RTC, PDMA, UART, SPI, I<sup>2</sup>C, I<sup>2</sup>S, PWM Timer, GPIO, PS/2, 12-bit ADC, Analog Comparator, Low Voltage Reset Controller and Brown-Out Detector.

The NuMicro™ NUC120 USB Line with USB 2.0 full-speed function embeds Cortex™-M0 core running up to 50 MHz with 32K/64K/128K-byte embedded flash, 4K/8K/16K-byte embedded SRAM, and 4K-byte loader ROM for the ISP. It also equips with plenty of peripheral devices, such as Timers, Watchdog Timer, RTC, PDMA, UART, SPI, I<sup>2</sup>C, I<sup>2</sup>S, PWM Timer, GPIO, PS/2, USB 2.0 FS Device, 12-bit ADC, Analog Comparator, Low Voltage Reset Controller and Brown-Out Detector.

Product Line	UART	SPI	I <sup>2</sup> C	USB	LIN	CAN	PS/2	I <sup>2</sup> S
NUC100	•	•	•				•	•
NUC120	•	•	•	•			•	•
NUC130	•	•	•		•	•	•	•
NUC140	•	•	•	•	•	•	•	•

Table 1-1 Connectivity Supported Table

## 2 FEATURES

The equipped features are dependent on the product line and their sub products.

### 2.1 NuMicro™ NUC100 Features – Advanced Line

- Core
  - ARM® Cortex™-M0 core runs up to 50 MHz
  - One 24-bit system timer
  - Supports low power sleep mode
  - Single-cycle 32-bit hardware multiplier
  - NVIC for the 32 interrupt inputs, each with 4-levels of priority
  - Serial Wire Debug supports with 2 watchpoints/4 breakpoints
- Build-in LDO for wide operating voltage ranges from 2.5 V to 5.5 V
- Flash Memory
  - 32K/64K/128K bytes Flash for program code (128KB only support in NuMicro™ NUC100/NUC120 Medium Density)
  - 4KB flash for ISP loader
  - Support In-system program (ISP) application code update
  - 512 byte page erase for flash
  - Configurable data flash address and size for 128KB system, fixed 4KB data flash for the 32KB and 64KB system
  - Support 2 wire ICP update through SWD/ICE interface
  - Support fast parallel programming mode by external programmer
- SRAM Memory
  - 4K/8K/16K bytes embedded SRAM (16KB only support in NuMicro™ NUC100/NUC120 Medium Density)
  - Support PDMA mode
- PDMA (Peripheral DMA)
  - Support 9 channels PDMA for automatic data transfer between SRAM and peripherals (Only support 1 channel in NuMicro™ NUC100/NUC120 Low Density)
- Clock Control
  - Flexible selection for different applications
  - Built-in 22.1184 MHz high speed OSC for system operation
    - ◆ Trimmed to  $\pm 1\%$  at  $+25\text{ }^{\circ}\text{C}$  and  $V_{DD} = 5\text{ V}$
    - ◆ Trimmed to  $\pm 3\%$  at  $-40\text{ }^{\circ}\text{C} \sim +85\text{ }^{\circ}\text{C}$  and  $V_{DD} = 2.5\text{ V} \sim 5.5\text{ V}$
  - Built-in 10 kHz low speed OSC for Watchdog Timer and Wake-up operation
  - Support one PLL, up to 50 MHz, for high performance system operation
  - External 4~24 MHz high speed crystal input for precise timing operation
  - External 32.768 kHz low speed crystal input for RTC function and low power system operation
- GPIO
  - Four I/O modes:
    - ◆ Quasi bi-direction
    - ◆ Push-Pull output
    - ◆ Open-Drain output
    - ◆ Input only with high impedance



- TTL/Schmitt trigger input selectable
- I/O pin can be configured as interrupt source with edge/level setting
- High driver and high sink IO mode support
- Timer
  - Support 4 sets of 32-bit timers with 24-bit up-timer and one 8-bit pre-scale counter
  - Independent clock source for each timer
  - Provides one-shot, periodic, toggle and continuous counting operation modes (NuMicro™ NUC100/NUC120 Medium Density only support one-shot and periodic mode)
  - Support event counting function (NuMicro™ NUC100/NUC120 Low Density only)
- Watchdog Timer
  - Multiple clock sources
  - 8 selectable time out period from 1.6ms ~ 26.0sec (depends on clock source)
  - WDT can wake-up from power down or idle mode
  - Interrupt or reset selectable on watchdog time-out
- RTC
  - Support software compensation by setting frequency compensate register (FCR)
  - Support RTC counter (second, minute, hour) and calendar counter (day, month, year)
  - Support Alarm registers (second, minute, hour, day, month, year)
  - Selectable 12-hour or 24-hour mode
  - Automatic leap year recognition
  - Support periodic time tick interrupt with 8 period options 1/128, 1/64, 1/32, 1/16, 1/8, 1/4, 1/2 and 1 second
  - Support wake-up function
- PWM/Capture
  - Built-in up to four 16-bit PWM generators provide eight PWM outputs or four complementary paired PWM outputs
  - Each PWM generator equipped with one clock source selector, one clock divider, one 8-bit prescaler and one Dead-Zone generator for complementary paired PWM
  - Up to eight 16-bit digital Capture timers (shared with PWM timers) provide eight rising/falling capture inputs
  - Support Capture interrupt
- UART
  - Up to three UART controllers (NuMicro™ NUC100/NUC120 Low Density only support 2 UART controllers)
  - UART ports with flow control (TXD, RXD, CTS and RTS)
  - UART0 with 63-byte FIFO is for high speed
  - UART1/2(optional) with 15-byte FIFO for standard device
  - Support IrDA (SIR) function
  - Support RS-485 9-bit mode and direction control. (NuMicro™ NUC100/NUC120 Low Density Only)
  - Programmable baud-rate generator up to 1/16 system clock
  - Support PDMA mode
- SPI
  - Up to four sets of SPI controller (NuMicro™ NUC100/NUC120 Low Density only support 2 SPI controllers)
  - Master up to 16 MHz, and Slave up to 10 MHz (chip working @ 5V)
  - Support SPI master/slave mode



- Full duplex synchronous serial data transfer
- Variable length of transfer data from 1 to 32 bits
- MSB or LSB first data transfer
- Rx and Tx on both rising or falling edge of serial clock independently
- 2 slave/device select lines when it is as the master, and 1 slave/device select line when it is as the slave
- Support byte suspend mode in 32-bit transmission
- Support PDMA mode
- I<sup>2</sup>C
  - Up to two sets of I<sup>2</sup>C device
  - Master/Slave mode
  - Bidirectional data transfer between masters and slaves
  - Multi-master bus (no central master)
  - Arbitration between simultaneously transmitting masters without corruption of serial data on the bus
  - Serial clock synchronization allows devices with different bit rates to communicate via one serial bus
  - Serial clock synchronization can be used as a handshake mechanism to suspend and resume serial transfer
  - Programmable clocks allow versatile rate control
  - Support multiple address recognition (four slave address with mask option)
- I<sup>2</sup>S
  - Interface with external audio CODEC
  - Operate as either master or slave mode
  - Capable of handling 8-, 16-, 24- and 32-bit word sizes
  - Mono and stereo audio data supported
  - I<sup>2</sup>S and MSB justified data format supported
  - Two 8 word FIFO data buffers are provided, one for transmit and one for receive
  - Generates interrupt requests when buffer levels cross a programmable boundary
  - Support two DMA requests, one for transmit and one for receive
- PS/2 Device Controller
  - Host communication inhibit and request to send detection
  - Reception frame error detection
  - Programmable 1 to 16 bytes transmit buffer to reduce CPU intervention
  - Double buffer for data reception
  - S/W override bus
- EBI (External bus interface) support (NuMicro™ NUC100/NUC120 Low Density 64-pin Package Only)
  - Accessible space: 64KB in 8-bit mode or 128KB in 16-bit mode
  - Support 8-/16-bit data width
  - Support byte write in 16-bit data width mode
- ADC
  - 12-bit SAR ADC with 600K SPS
  - Up to 8-ch single-end input or 4-ch differential input
  - Single scan/single cycle scan/continuous scan
  - Each channel with individual result register
  - Scan on enabled channels
  - Threshold voltage detection
  - Conversion start by software programming or external input
  - Support PDMA mode



- Analog Comparator
  - Up to two analog comparators
  - External input or internal bandgap voltage selectable at negative node
  - Interrupt when compare result change
  - Power down wake-up
- One built-in temperature sensor with 1°C resolution
- Brown-Out detector
  - With 4 levels: 4.5 V/3.8 V/2.7 V/2.2 V
  - Support Brown-Out Interrupt and Reset option
- Low Voltage Reset
  - Threshold voltage levels: 2.0 V
- Operating Temperature: -40°C~85°C
- Packages:
  - All Green package (RoHS)
  - LQFP 100-pin / 64-pin / 48-pin (100-pin for NuMicro™ NUC100/NUC120 Medium Density Only)



## 2.2 NuMicro™ NUC120 Features – USB Line

- Core
  - ARM® Cortex™-M0 core runs up to 50 MHz
  - One 24-bit system timer
  - Supports low power sleep mode
  - Single-cycle 32-bit hardware multiplier
  - NVIC for the 32 interrupt inputs, each with 4-levels of priority
  - Serial Wire Debug supports with 2 watchpoints/4 breakpoints
- Build-in LDO for wide operating voltage ranges from 2.5 V to 5.5 V
- Flash Memory
  - 32K/64K/128K bytes Flash for program code (128KB only support in NuMicro™ NUC100/NUC120 Medium Density)
  - 4KB flash for ISP loader
  - Support In-system program (ISP) application code update
  - 512 byte page erase for flash
  - Configurable data flash address and size for 128KB system, fixed 4KB data flash for the 32KB and 64KB system
  - Support 2 wire ICP update through SWD/ICE interface
  - Support fast parallel programming mode by external programmer
- SRAM Memory
  - 4K/8K/16K bytes embedded SRAM (16KB only support in NuMicro™ NUC100/NUC120 Medium Density)
  - Support PDMA mode
- PDMA (Peripheral DMA)
  - Support 9 channels PDMA for automatic data transfer between SRAM and peripherals (Only support 1 channel in NuMicro™ NUC100/NUC120 Low Density)
- Clock Control
  - Flexible selection for different applications
  - Built-in 22.1184 MHz high speed OSC for system operation
    - ◆ Trimmed to  $\pm 1\%$  at +25 °C and  $V_{DD} = 5\text{ V}$
    - ◆ Trimmed to  $\pm 3\%$  at -40 °C ~ +85 °C and  $V_{DD} = 2.5\text{ V} \sim 5.5\text{ V}$
  - Built-in 10 KHz low speed OSC for Watchdog Timer and Wake-up operation
  - Support one PLL, up to 50 MHz, for high performance system operation
  - External 4~24 MHz high speed crystal input for USB and precise timing operation
  - External 32.768 kHz low speed crystal input for RTC function and low power system operation
- GPIO
  - Four I/O modes:
    - ◆ Quasi bi-direction
    - ◆ Push-Pull output
    - ◆ Open-Drain output
    - ◆ Input only with high impedance
  - TTL/Schmitt trigger input selectable
  - I/O pin can be configured as interrupt source with edge/level setting
  - High driver and high sink IO mode support

- Timer
  - Support 4 sets of 32-bit timers with 24-bit up-timer and one 8-bit pre-scale counter
  - Independent clock source for each timer
  - Provides one-shot, periodic, toggle and continuous counting operation modes (NuMicro™ NUC100/NUC120 Medium Density only support one-shot and periodic mode)
  - Support event counting function (NuMicro™ NUC100/NUC120 Low Density only)
- Watchdog Timer
  - Multiple clock sources
  - 8 selectable time out period from 1.6ms ~ 26.0sec (depends on clock source)
  - WDT can wake-up from power down or idle mode
  - Interrupt or reset selectable on watchdog time-out
- RTC
  - Support software compensation by setting frequency compensate register (FCR)
  - Support RTC counter (second, minute, hour) and calendar counter (day, month, year)
  - Support Alarm registers (second, minute, hour, day, month, year)
  - Selectable 12-hour or 24-hour mode
  - Automatic leap year recognition
  - Support periodic time tick interrupt with 8 period options 1/128, 1/64, 1/32, 1/16, 1/8, 1/4, 1/2 and 1 second
  - Support wake-up function
- PWM/Capture
  - Built-in up to four 16-bit PWM generators provide eight PWM outputs or four complementary paired PWM outputs
  - Each PWM generator equipped with one clock source selector, one clock divider, one 8-bit prescaler and one Dead-Zone generator for complementary paired PWM
  - Up to eight 16-bit digital Capture timers (shared with PWM timers) provide eight rising/falling capture inputs
  - Support Capture interrupt
- UART
  - Up to three UART controllers (NuMicro™ NUC100/NUC120 Low Density only support 2 UART controllers)
  - UART ports with flow control (TXD, RXD, CTS and RTS)
  - UART0 with 63-byte FIFO is for high speed
  - UART1/2(optional) with 15-byte FIFO for standard device
  - Support IrDA (SIR) function
  - Support RS-485 9-bit mode and direction control. (NuMicro™ NUC100/NUC120 Low Density Only)
  - Programmable baud-rate generator up to 1/16 system clock
  - Support PDMA mode
- SPI
  - Up to four sets of SPI controller (NuMicro™ NUC100/NUC120 Low Density only support 2 SPI controllers)
  - Master up to 16 MHz, and Slave up to 10 MHz (chip working @ 5V)
  - Support SPI master/slave mode
  - Full duplex synchronous serial data transfer
  - Variable length of transfer data from 1 to 32 bits
  - MSB or LSB first data transfer
  - Rx and Tx on both rising or falling edge of serial clock independently



- 2 slave/device select lines when it is as the master, and 1 slave/device select line when it is as the slave
- Support byte suspend mode in 32-bit transmission
- Support PDMA mode
- I<sup>2</sup>C
  - Up to two sets of I<sup>2</sup>C device
  - Master/Slave mode
  - Bidirectional data transfer between masters and slaves
  - Multi-master bus (no central master)
  - Arbitration between simultaneously transmitting masters without corruption of serial data on the bus
  - Serial clock synchronization allows devices with different bit rates to communicate via one serial bus
  - Serial clock synchronization can be used as a handshake mechanism to suspend and resume serial transfer
  - Programmable clocks allow versatile rate control
  - Support multiple address recognition (four slave address with mask option)
- I<sup>2</sup>S
  - Interface with external audio CODEC
  - Operate as either master or slave mode
  - Capable of handling 8-, 16-, 24- and 32-bit word sizes
  - Mono and stereo audio data supported
  - I<sup>2</sup>S and MSB justified data format supported
  - Two 8 word FIFO data buffers are provided, one for transmit and one for receive
  - Generates interrupt requests when buffer levels cross a programmable boundary
  - Support two DMA requests, one for transmit and one for receive
- PS/2 Device Controller
  - Host communication inhibit and request to send detection
  - Reception frame error detection
  - Programmable 1 to 16 bytes transmit buffer to reduce CPU intervention
  - Double buffer for data reception
  - S/W override bus
- USB 2.0 Full-Speed Device
  - One set of USB 2.0 FS Device 12Mbps
  - On-chip USB Transceiver
  - Provide 1 interrupt source with 4 interrupt events
  - Support Control, Bulk In/Out, Interrupt and Isochronous transfers
  - Auto suspend function when no bus signaling for 3 ms
  - Provide 6 programmable endpoints
  - Include 512 Bytes internal SRAM as USB buffer
  - Provide remote wake-up capability
- EBI (External bus interface) support (NuMicro™ NUC100/NUC120 Low Density 64-pin Package Only)
  - Accessible space: 64KB in 8-bit mode or 128KB in 16-bit mode
  - Support 8-/16-bit data width
  - Support byte write in 16-bit data width mode
- ADC
  - 12-bit SAR ADC with 600K SPS
  - Up to 8-ch single-end input or 4-ch differential input



- Single scan/single cycle scan/continuous scan
- Each channel with individual result register
- Scan on enabled channels
- Threshold voltage detection
- Conversion start by software programming or external input
- Support PDMA mode
- Analog Comparator
  - Up to two analog comparators
  - External input or internal bandgap voltage selectable at negative node
  - Interrupt when compare result change
  - Power down wake-up
- One built-in temperature sensor with 1°C resolution
- Brown-Out detector
  - With 4 levels: 4.5 V/3.8 V/2.7 V/2.2 V
  - Support Brown-Out Interrupt and Reset option
- Low Voltage Reset
  - Threshold voltage levels: 2.0 V
- Operating Temperature: -40°C~85°C
- Packages:
  - All Green package (RoHS)
  - LQFP 100-pin / 64-pin / 48-pin (100-pin for NuMicro™ NUC100/NUC120 Medium Density Only)



## 3 PARTS INFORMATION LIST AND PIN CONFIGURATION

### 3.1 NuMicro™ NUC100 Products Selection Guide

#### 3.1.1 NuMicro™ NUC100 Medium Density Advance Line Selection Guide

Part number	APROM	RAM	Data Flash	ISP Loader ROM	I/O	Timer	Connectivity						i <sup>2</sup> S	Comp.	PWM	ADC	RTC	EBI	ISP ICP	Package
							UART	SPI	I <sup>2</sup> C	USB	LIN	CAN								
NUC100LD3AN	64 KB	16 KB	4 KB	4 KB	up to 35	4x32-bit	2	1	2	-	-	-	1	1	6	8x12-bit	v	-	v	LQFP48
NUC100LE3AN	128 KB	16 KB	Definable	4 KB	up to 35	4x32-bit	2	1	2	-	-	-	1	1	6	8x12-bit	v	-	v	LQFP48
NUC100RD3AN	64 KB	16 KB	4 KB	4 KB	up to 49	4x32-bit	3	2	2	-	-	-	1	2	6	8x12-bit	v	-	v	LQFP64
NUC100RE3AN	128 KB	16 KB	Definable	4 KB	up to 49	4x32-bit	3	2	2	-	-	-	1	2	6	8x12-bit	v	-	v	LQFP64
NUC100VD2AN	64 KB	8 KB	4 KB	4 KB	up to 80	4x32-bit	3	4	2	-	-	-	1	2	8	8x12-bit	v	-	v	LQFP100
NUC100VD3AN	64 KB	16 KB	4 KB	4 KB	up to 80	4x32-bit	3	4	2	-	-	-	1	2	8	8x12-bit	v	-	v	LQFP100
NUC100VE3AN	128 KB	16 KB	Definable	4 KB	up to 80	4x32-bit	3	4	2	-	-	-	1	2	8	8x12-bit	v	-	v	LQFP100

#### 3.1.2 NuMicro™ NUC100 Low Density Advance Line Selection Guide

Part number	APROM	RAM	Data Flash	ISP Loader ROM	I/O	Timer	Connectivity						i <sup>2</sup> S	Comp.	PWM	ADC	RTC	EBI	ISP ICP	Package
							UART	SPI	I <sup>2</sup> C	USB	LIN	CAN								
NUC100LC1BN	32 KB	4 KB	4 KB	4 KB	up to 35	4x32-bit	2	1	2	-	-	-	1	1	4	8x12-bit	v	-	v	LQFP48
NUC100LD1BN	64 KB	4 KB	4 KB	4 KB	up to 35	4x32-bit	2	1	2	-	-	-	1	1	4	8x12-bit	v	-	v	LQFP48
NUC100LD2BN	64 KB	8 KB	4 KB	4 KB	up to 35	4x32-bit	2	1	2	-	-	-	1	1	4	8x12-bit	v	-	v	LQFP48
NUC100RC1BN	32 KB	4 KB	4 KB	4 KB	up to 49	4x32-bit	2	2	2	-	-	-	1	2	4	8x12-bit	v	v	v	LQFP64
NUC100RD1BN	64 KB	4 KB	4 KB	4 KB	up to 49	4x32-bit	2	2	2	-	-	-	1	2	4	8x12-bit	v	v	v	LQFP64
NUC100RD2BN	64 KB	8 KB	4 KB	4 KB	up to 49	4x32-bit	2	2	2	-	-	-	1	2	4	8x12-bit	v	v	v	LQFP64



## 3.2 NuMicro™ NUC120 Products Selection Guide

### 3.2.1 NuMicro™ NUC120 Medium Density USB Line Selection Guide

Part number	APROM	RAM	Data Flash	ISP Loader ROM	I/O	Timer	Connectivity						i <sup>2</sup> S	Comp.	PWM	ADC	RTC	EBI	ISP ICP	Package
							UART	SPI	I <sup>2</sup> C	USB	LIN	CAN								
NUC120LD3AN	64 KB	16 KB	4 KB	4 KB	up to 31	4x32-bit	2	1	2	1	-	-	1	1	4	8x12-bit	v	-	v	LQFP48
NUC120LE3AN	128 KB	16 KB	Definable	4 KB	up to 31	4x32-bit	2	1	2	1	-	-	1	1	4	8x12-bit	v	-	v	LQFP48
NUC120RD3AN	64 KB	16 KB	4 KB	4 KB	up to 45	4x32-bit	2	2	2	1	-	-	1	2	6	8x12-bit	v	-	v	LQFP64
NUC120RE3AN	128 KB	16 KB	Definable	4 KB	up to 45	4x32-bit	2	2	2	1	-	-	1	2	6	8x12-bit	v	-	v	LQFP64
NUC120VD2AN	64 KB	8 KB	4 KB	4 KB	up to 76	4x32-bit	3	4	2	1	-	-	1	2	8	8x12-bit	v	-	v	LQFP100
NUC120VD3AN	64 KB	16 KB	4 KB	4 KB	up to 76	4x32-bit	3	4	2	1	-	-	1	2	8	8x12-bit	v	-	v	LQFP100
NUC120VE3AN	128 KB	16 KB	Definable	4 KB	up to 76	4x32-bit	3	4	2	1	-	-	1	2	8	8x12-bit	v	-	v	LQFP100

### 3.2.2 NuMicro™ NUC120 Low Density USB Line Selection Guide

Part number	APROM	RAM	Data Flash	ISP Loader ROM	I/O	Timer	Connectivity						i <sup>2</sup> S	Comp.	PWM	ADC	RTC	EBI	ISP ICP	Package
							UART	SPI	I <sup>2</sup> C	USB	LIN	CAN								
NUC120LC1BN	32 KB	4 KB	4 KB	4 KB	up to 31	4x32-bit	2	1	2	1	-	-	1	1	4	8x12-bit	v	-	v	LQFP48
NUC120LD1BN	64 KB	4 KB	4 KB	4 KB	up to 31	4x32-bit	2	1	2	1	-	-	1	1	4	8x12-bit	v	-	v	LQFP48
NUC120LD2BN	64 KB	8 KB	4 KB	4 KB	up to 31	4x32-bit	2	1	2	1	-	-	1	1	4	8x12-bit	v	-	v	LQFP48
NUC120RC1BN	32 KB	4 KB	4 KB	4 KB	up to 45	4x32-bit	2	2	2	1	-	-	1	2	4	8x12-bit	v	v	v	LQFP64
NUC120RD1BN	64 KB	4 KB	4 KB	4 KB	up to 45	4x32-bit	2	2	2	1	-	-	1	2	4	8x12-bit	v	v	v	LQFP64
NUC120RD2BN	64 KB	8 KB	4 KB	4 KB	up to 45	4x32-bit	2	2	2	1	-	-	1	2	4	8x12-bit	v	v	v	LQFP64

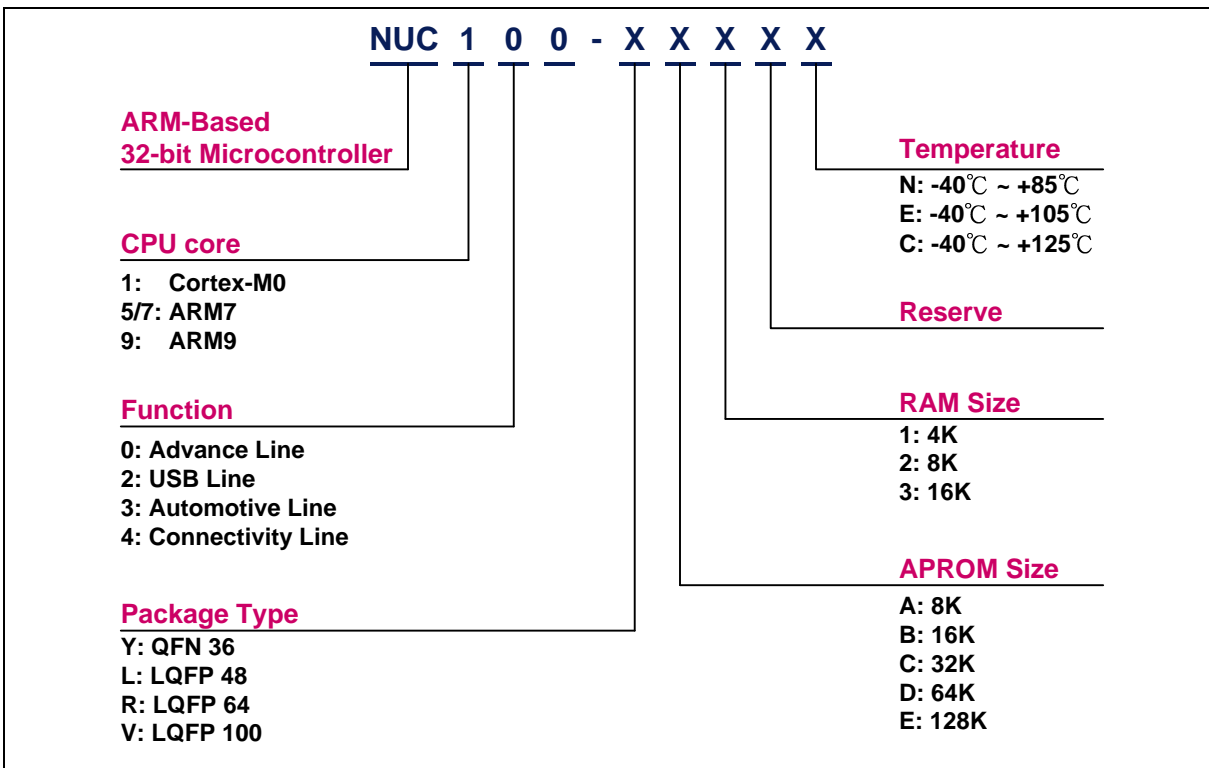

Figure 3-1 NuMicro™ NUC100 Series selection code



## 3.3 Pin Configuration

### 3.3.1 NuMicro™ NUC100/NUC120 Medium Density Pin Diagram

#### 3.3.1.1 NuMicro™ NUC100 Medium Density LQFP 100 pin

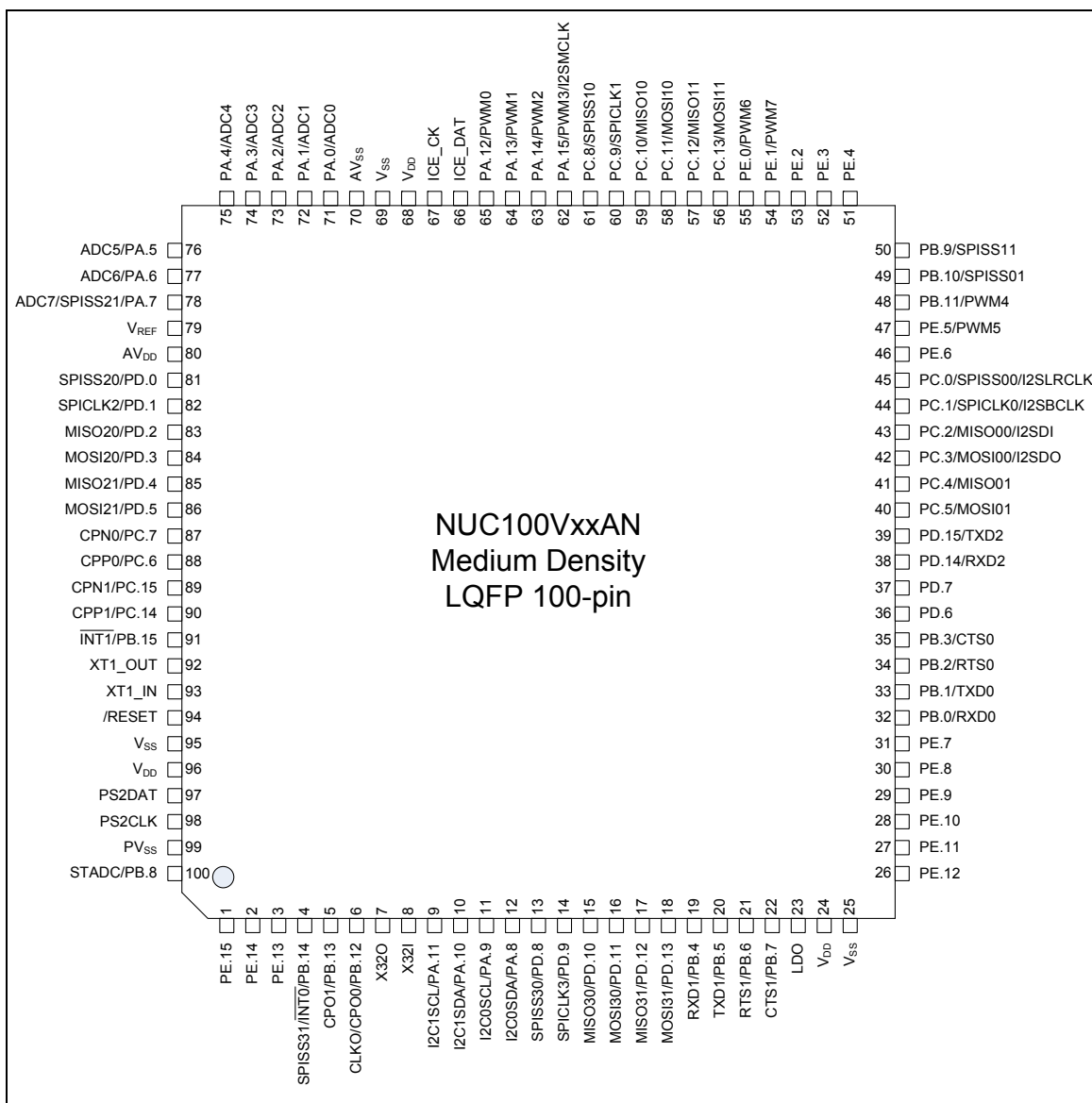

Figure 3-2 NuMicro™ NUC100 Medium Density LQFP 100-pin Pin Diagram





## 3.3.1.2 NuMicro™ NUC100 Medium Density LQFP 64 pin

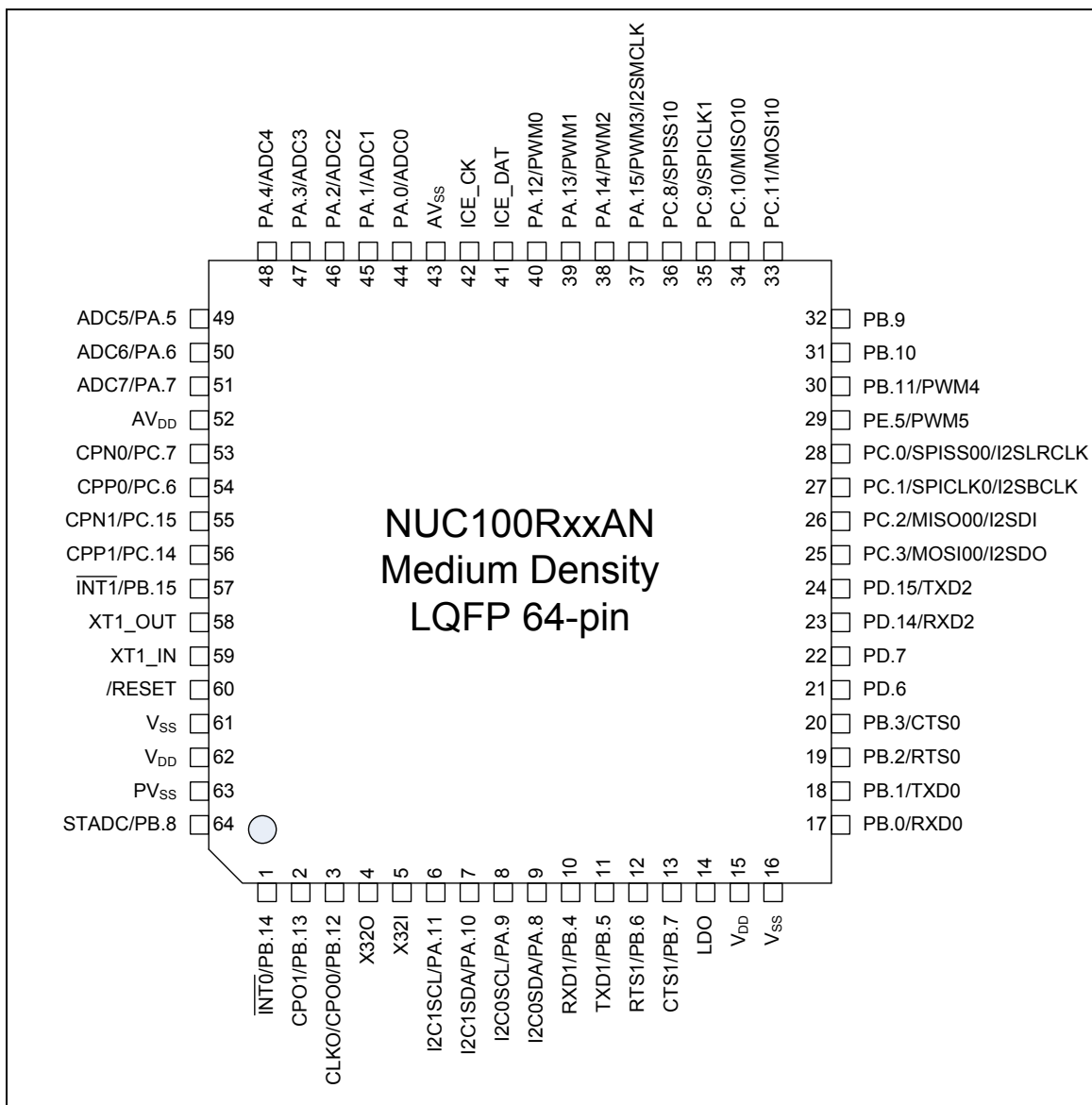

Figure 3-3 NuMicro™ NUC100 Medium Density LQFP 64-pin Pin Diagram



### 3.3.1.3 NuMicro™ NUC100 Medium Density LQFP 48 pin

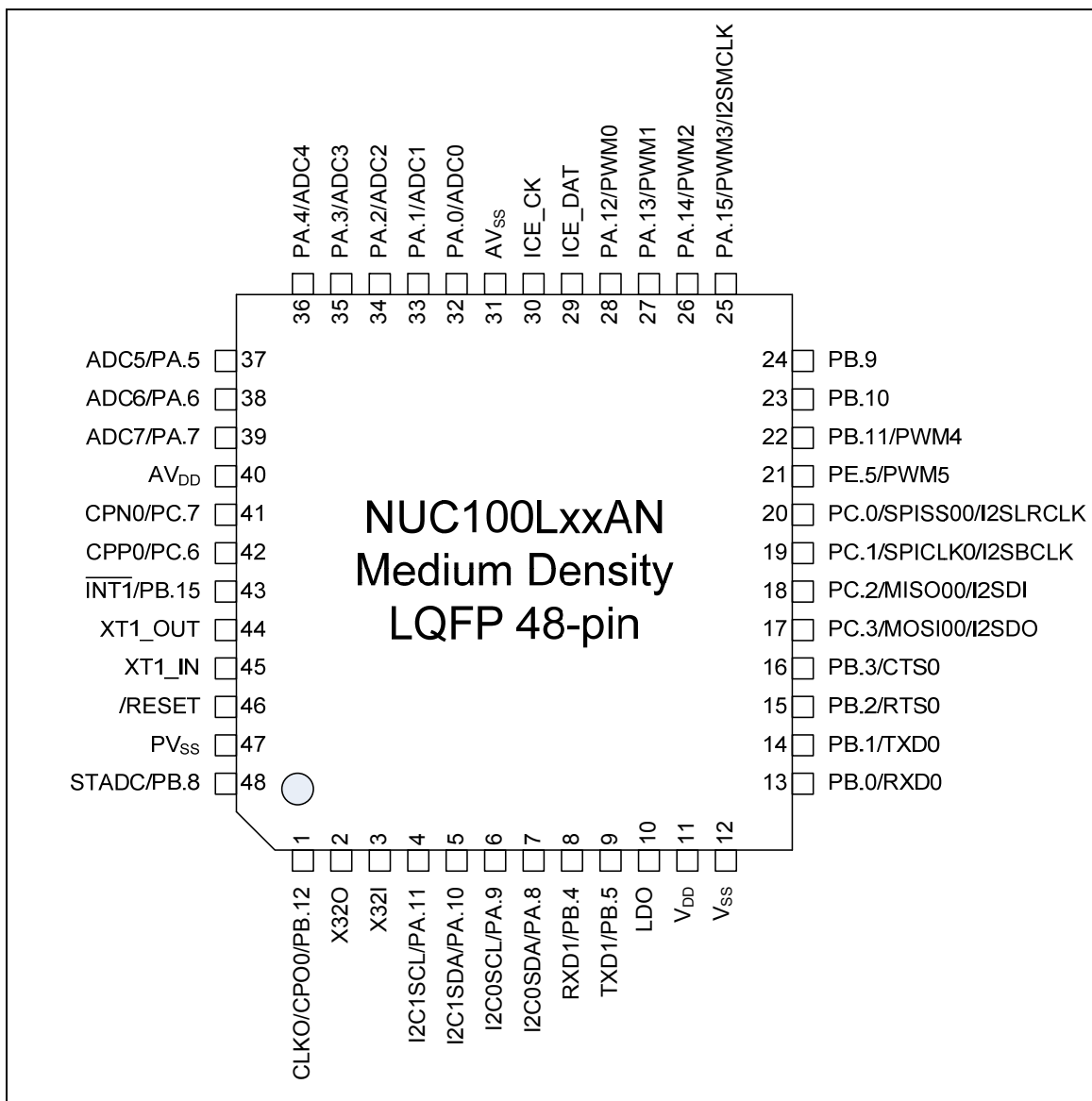

Figure 3-4 NuMicro™ NUC100 Medium Density LQFP 48-pin Pin Diagram



## 3.3.1.4 NuMicro™ NUC120 Medium Density LQFP 100 pin

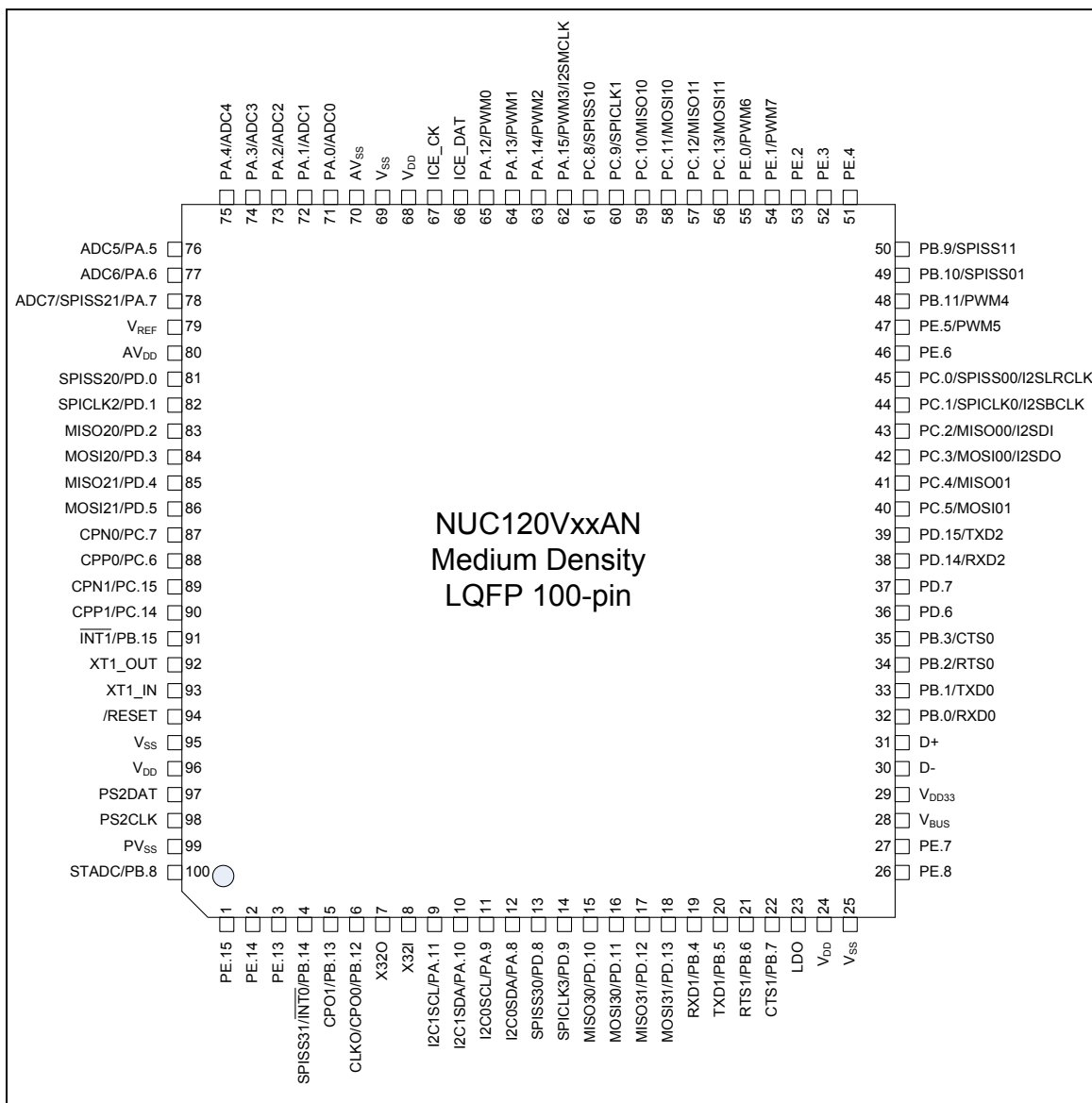

Figure 3-5 NuMicro™ NUC120 Medium Density LQFP 100-pin Pin Diagram



## 3.3.1.5 NuMicro™ NUC120 Medium Density LQFP 64 pin

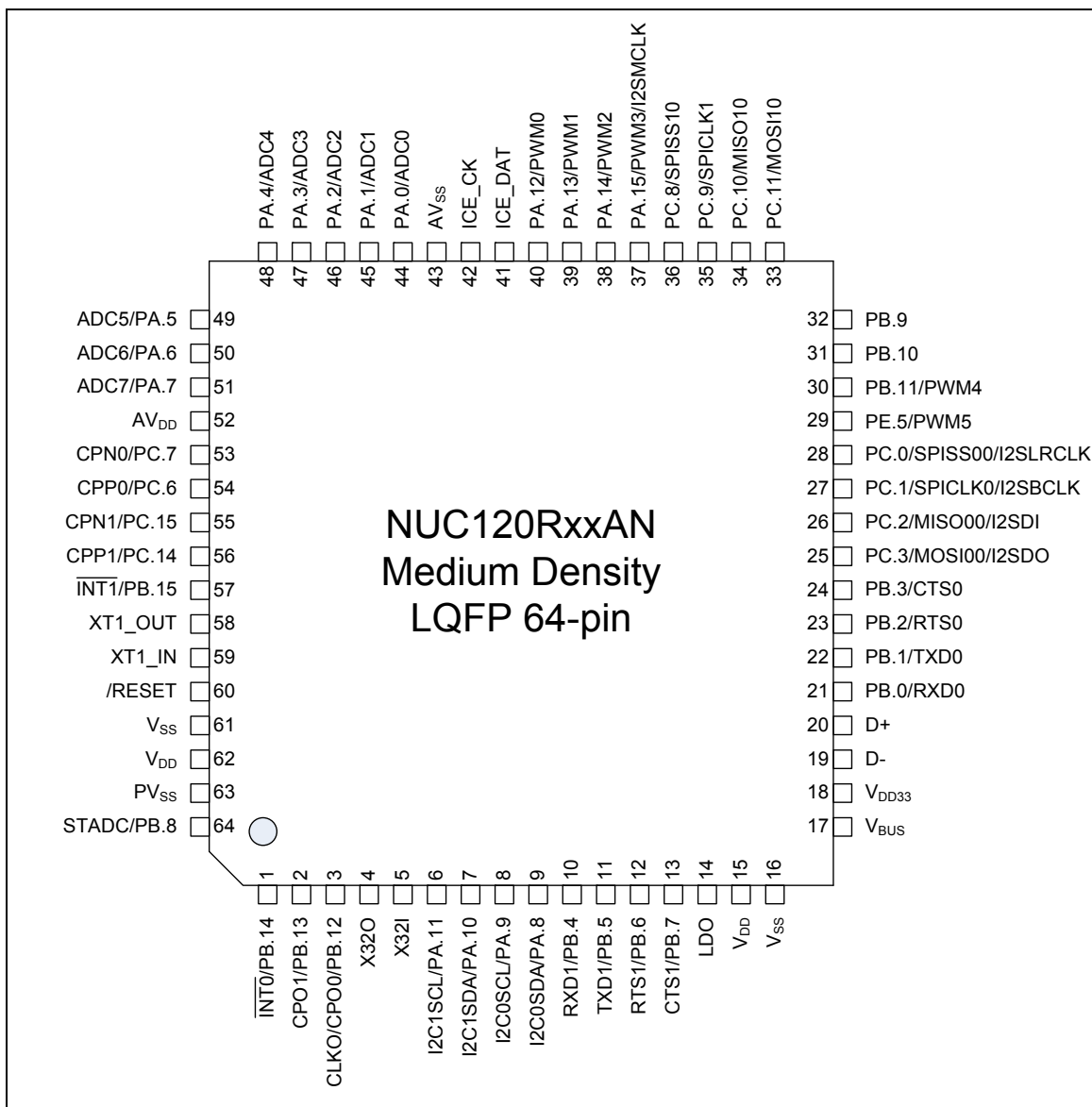

Figure 3-6 NuMicro™ NUC120 Medium Density LQFP 64-pin Pin Diagram



## 3.3.1.6 NuMicro™ NUC120 Medium Density LQFP 48 pin

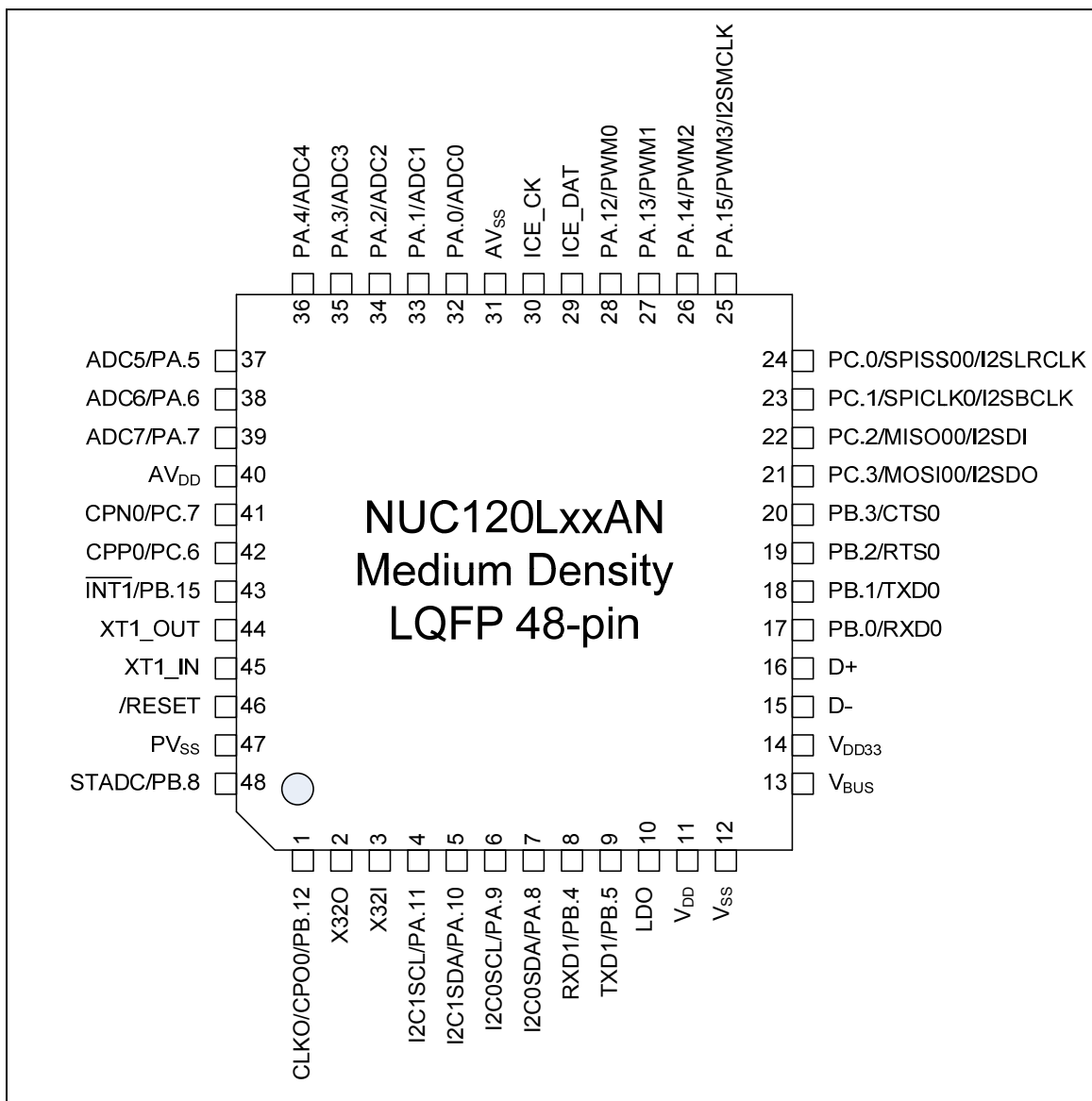

Figure 3-7 NuMicro™ NUC120 Medium Density LQFP 48-pin Pin Diagram



## 3.3.2 NuMicro™ NUC100/NUC120 Low Density Pin Diagram

### 3.3.2.1 NuMicro™ NUC100 Low Density LQFP 64 pin

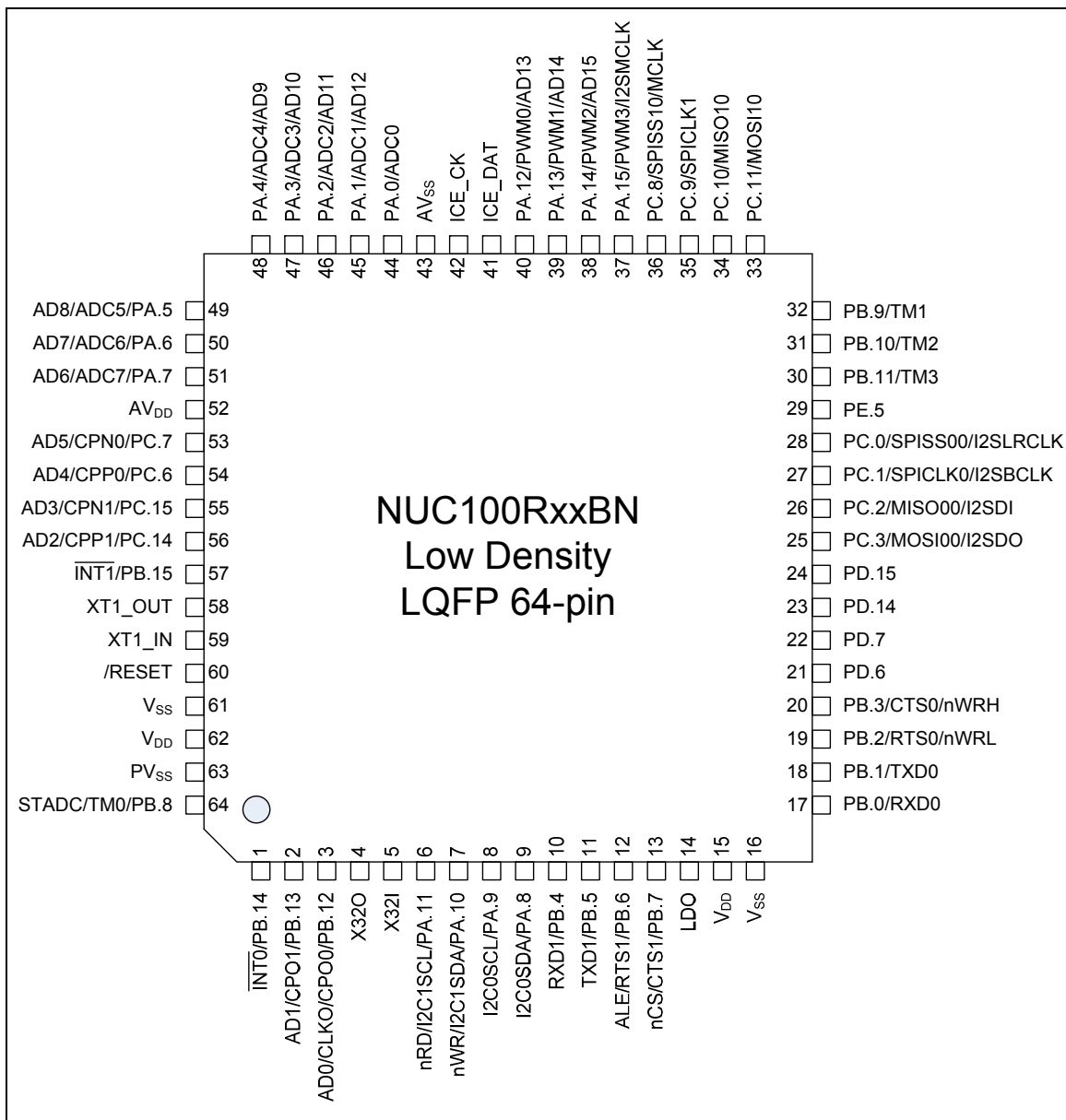

Figure 3-8 NuMicro™ NUC100 Low Density LQFP 64-pin Pin Diagram



## 3.3.2.2 NuMicro™ NUC100 Low Density LQFP 48 pin

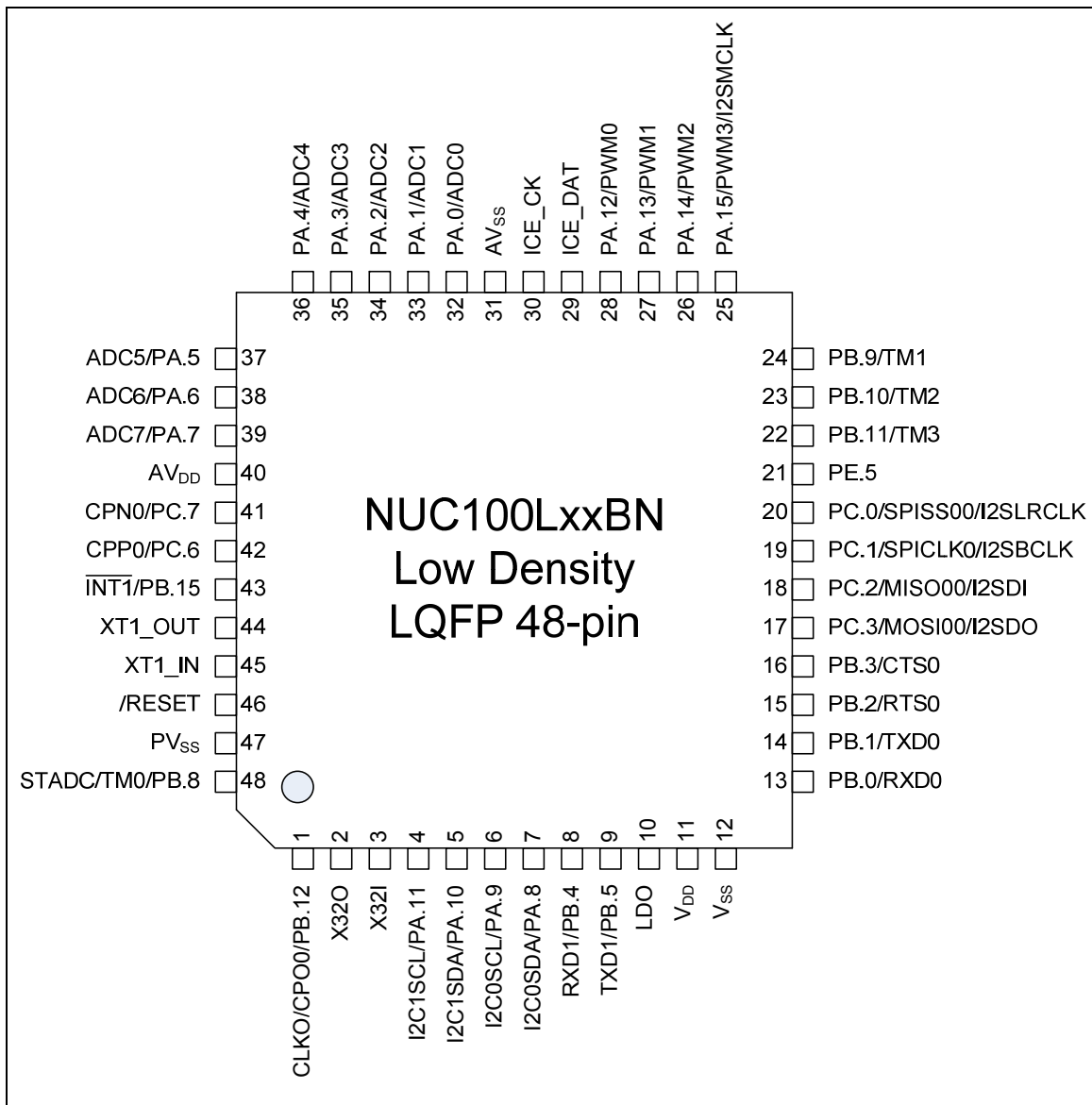

Figure 3-9 NuMicro™ NUC100 Low Density LQFP 48-pin Pin Diagram



### 3.3.2.3 NuMicro™ NUC120 Low Density LQFP 64 pin

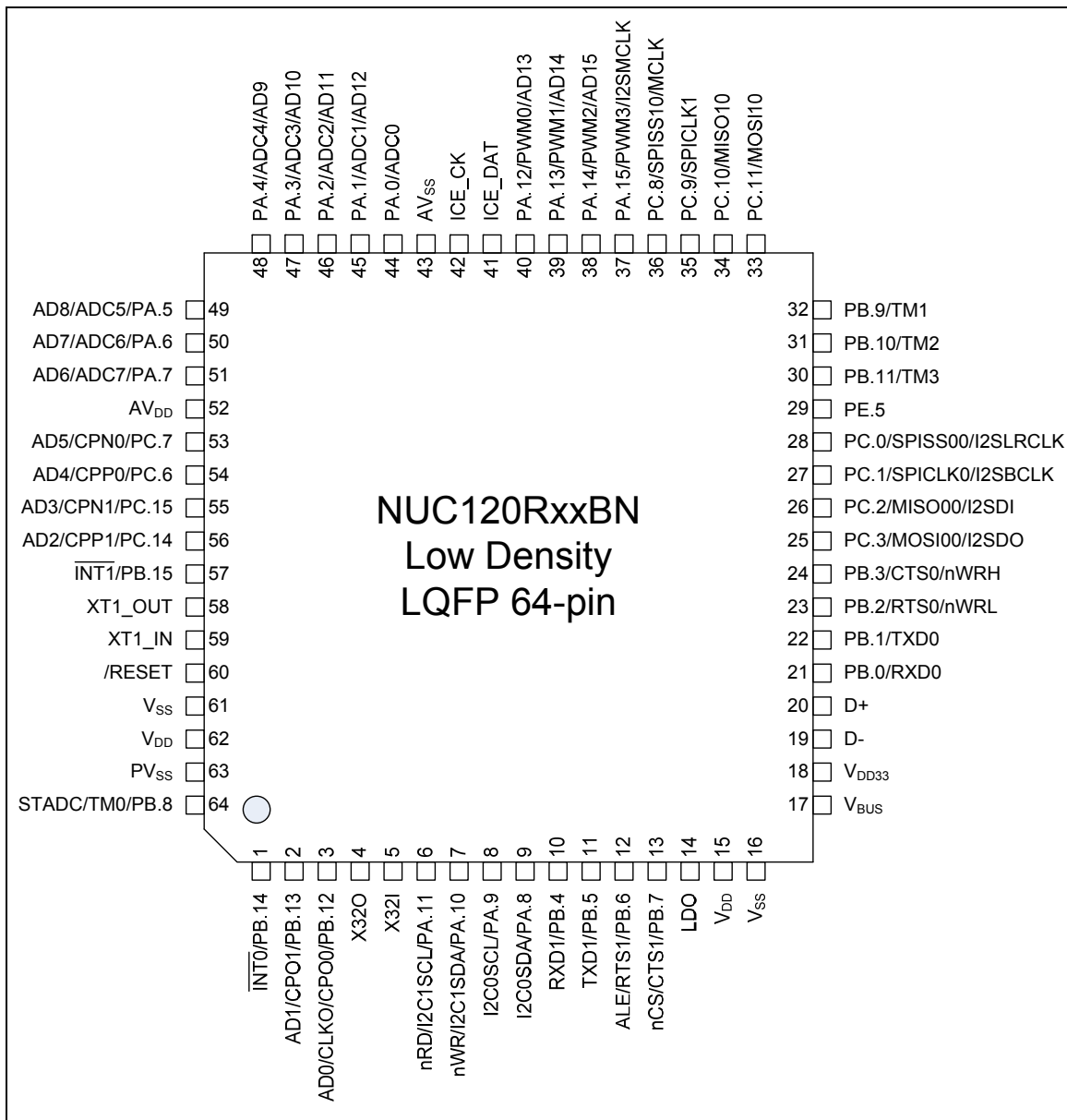

Figure 3-10 NuMicro™ NUC120 Low Density LQFP 64-pin Pin Diagram





## 3.3.2.4 NuMicro™ NUC120 Low Density LQFP 48 pin

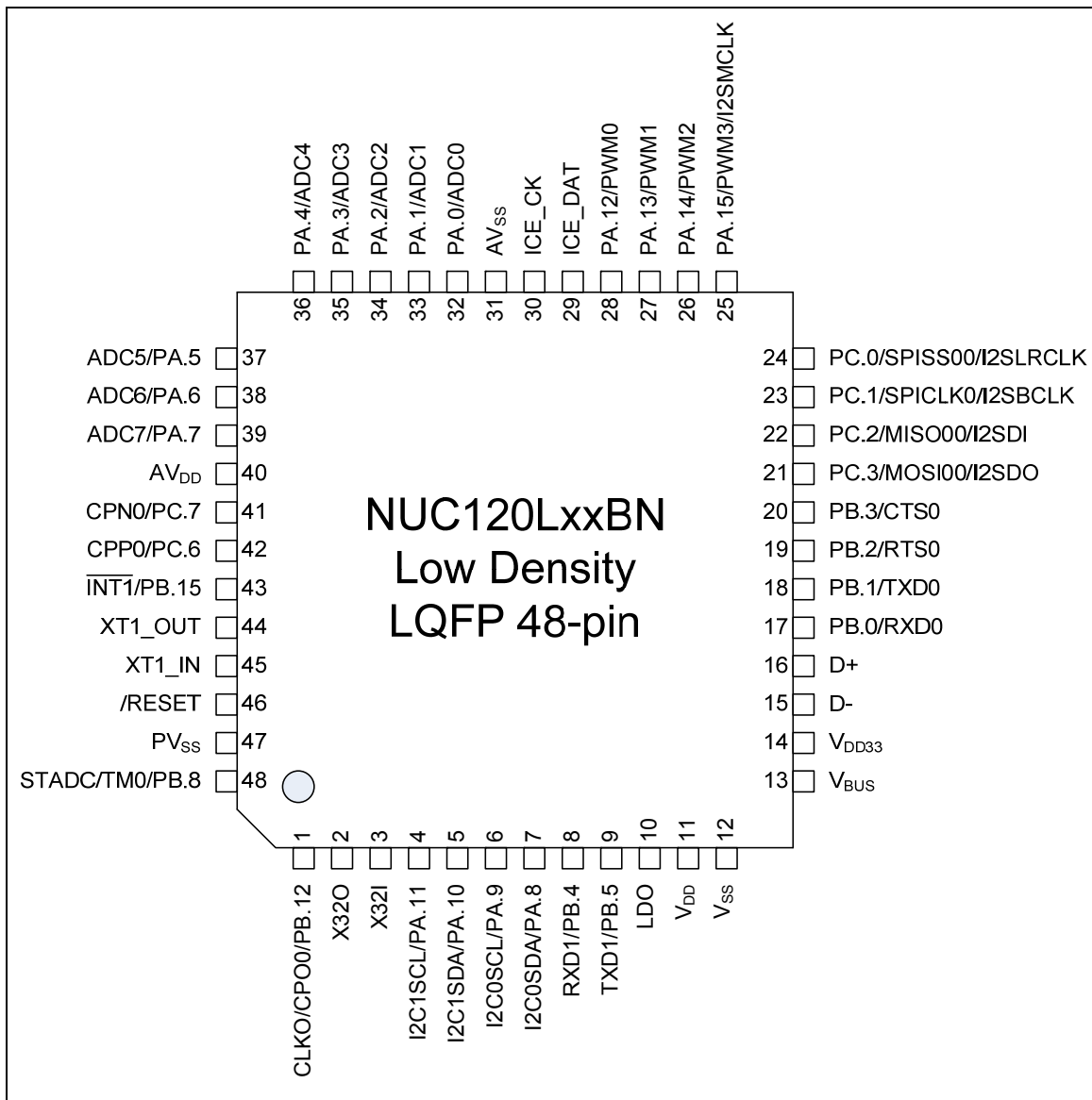

Figure 3-11 NuMicro™ NUC120 Low Density LQFP 48-pin Pin Diagram



## 3.4 Pin Description

### 3.4.1 NuMicro™ NUC100/NUC120 Medium Density Pin Description

#### 3.4.1.1 NuMicro™ NUC100 Medium Density Pin Description

Pin No.			Pin Name	Pin Type	Description
LQFP 100	LQFP 64	LQFP 48			
1			PE.15	I/O	General purpose input/output digital pin
2			PE.14	I/O	General purpose input/output digital pin
3			PE.13	I/O	General purpose input/output digital pin
4	1		PB.14	I/O	General purpose input/output digital pin
			/INT0	I	/INT0: External interrupt1 input pin
			SPISS31	I/O	SPISS31: SPI3 2 <sup>nd</sup> slave select pin
5	2		PB.13	I/O	General purpose input/output digital pin
			CPO1	O	Comparator1 output pin
6	3	1	PB.12	I/O	General purpose input/output digital pin
			CPO0	O	Comparator0 output pin
			CLKO	O	Frequency Divider output pin
7	4	2	X32O	O	External 32.768 kHz low speed crystal output pin
8	5	3	X32I	I	External 32.768 kHz low speed crystal input pin
9	6	4	PA.11	I/O	General purpose input/output digital pin
			I2C1SCL	I/O	I2C1SCL: I <sup>2</sup> C1 clock pin
10	7	5	PA.10	I/O	General purpose input/output digital pin
			I2C1SDA	I/O	I2C1SDA: I <sup>2</sup> C1 data input/output pin
11	8	6	PA.9	I/O	General purpose input/output digital pin
			I2C0SCL	I/O	I2C0SCL: I <sup>2</sup> C0 clock pin
12	9	7	PA.8	I/O	General purpose input/output digital pin
			I2C0SDA	I/O	I2C0SDA: I <sup>2</sup> C0 data input/output pin
13			PD.8	I/O	General purpose input/output digital pin
			SPISS30	I/O	SPISS30: SPI3 slave select pin
14			PD.9	I/O	General purpose input/output digital pin
			SPICLK3	I/O	SPICLK3: SPI3 serial clock pin



Pin No.			Pin Name	Pin Type	Description
LQFP 100	LQFP 64	LQFP 48			
15			PD.10	I/O	General purpose input/output digital pin
			MISO30	I/O	MISO30: SPI3 MISO (Master In, Slave Out) pin
16			PD.11	I/O	General purpose input/output digital pin
			MOSI30	I/O	MOSI30: SPI3 MOSI (Master Out, Slave In) pin
17			PD.12	I/O	General purpose input/output digital pin
			MISO31	I/O	MISO31: SPI3 2 <sup>nd</sup> MISO (Master In, Slave Out) pin
18			PD.13	I/O	General purpose input/output digital pin
			MOSI31	I/O	MOSI31: SPI3 2 <sup>nd</sup> MOSI (Master Out, Slave In) pin
19	10	8	PB.4	I/O	General purpose input/output digital pin
			RXD1	I	RXD1: Data receiver input pin for UART1
20	11	9	PB.5	I/O	General purpose input/output digital pin
			TXD1	O	TXD1: Data transmitter output pin for UART1
21	12		PB.6	I/O	General purpose input/output digital pin
			RTS1	O	RTS1: Request to Send output pin for UART1
22	13		PB.7	I/O	General purpose input/output digital pin
			CTS1	I	CTS1: Clear to Send input pin for UART1
23	14	10	LDO	P	LDO output pin
24	15	11	V <sub>DD</sub>	P	Power supply for I/O ports and LDO source for internal PLL and digital function
25	16	12	V <sub>SS</sub>	P	Ground
26			PE.12	I/O	General purpose input/output digital pin
27			PE.11	I/O	General purpose input/output digital pin
28			PE.10	I/O	General purpose input/output digital pin
29			PE.9	I/O	General purpose input/output digital pin
30			PE.8	I/O	General purpose input/output digital pin
31			PE.7	I/O	General purpose input/output digital pin
32	17	13	PB.0	I/O	General purpose input/output digital pin
			RXD0	I	RXD0: Data receiver input pin for UART0
33	18	14	PB.1	I/O	General purpose input/output digital pin
			TXD0	O	TXD0: Data transmitter output pin for UART0



Pin No.			Pin Name	Pin Type	Description
LQFP 100	LQFP 64	LQFP 48			
34	19	15	PB.2	I/O	General purpose input/output digital pin
			RTS0	O	RTS0: Request to Send output pin for UART0
35	20	16	PB.3	I/O	General purpose input/output digital pin
			CTS0	I	CTS0: Clear to Send input pin for UART0
36	21		PD.6	I/O	General purpose input/output digital pin
37	22		PD.7	I/O	General purpose input/output digital pin
38	23		PD.14	I/O	General purpose input/output digital pin
			RXD2	I	RXD2: Data receiver input pin for UART2
39	24		PD.15	I/O	General purpose input/output digital pin
			TXD2	O	TXD2: Data transmitter output pin for UART2
40			PC.5	I/O	General purpose input/output digital pin
			MOSI01	I/O	MOSI01: SPI0 2 <sup>nd</sup> MOSI (Master Out, Slave In) pin
41			PC.4	I/O	General purpose input/output digital pin
			MISO01	I/O	MISO01: SPI0 2 <sup>nd</sup> MISO (Master In, Slave Out) pin
42	25	17	PC.3	I/O	General purpose input/output digital pin
			MOSI00	I/O	MOSI00: SPI0 MOSI (Master Out, Slave In) pin
			I2SDO	O	I2SDO: I <sup>2</sup> S data output
43	26	18	PC.2	I/O	General purpose input/output digital pin
			MISO00	I/O	MISO00: SPI0 MISO (Master In, Slave Out) pin
			I2SDI	I	I2SDI: I <sup>2</sup> S data input
44	27	19	PC.1	I/O	General purpose input/output digital pin
			SPICLK0	I/O	SPICLK0: SPI0 serial clock pin
			I2SBCLK	I/O	I2SBCLK: I <sup>2</sup> S bit clock pin
45	28	20	PC.0	I/O	General purpose input/output digital pin
			SPISS00	I/O	SPISS00: SPI0 slave select pin
			I2SLRCLK	I/O	I2SLRCLK: I <sup>2</sup> S left right channel clock
46			PE.6	I/O	General purpose input/output digital pin
47	29	21	PE.5	I/O	General purpose input/output digital pin
			PWM5	I/O	PWM5: PWM output/Capture input



Pin No.			Pin Name	Pin Type	Description
LQFP 100	LQFP 64	LQFP 48			
48	30	22	PB.11	I/O	General purpose input/output digital pin
			PWM4	I/O	PWM4: PWM output/Capture input
49	31	23	PB.10	I/O	General purpose input/output digital pin
			SPISS01	I/O	SPISS01: SPI0 2 <sup>nd</sup> slave select pin
50	32	24	PB.9	I/O	General purpose input/output digital pin
			SPISS11	I/O	SPISS11: SPI1 2 <sup>nd</sup> slave select pin
51			PE.4	I/O	General purpose input/output digital pin
52			PE.3	I/O	General purpose input/output digital pin
53			PE.2	I/O	General purpose input/output digital pin
54			PE.1	I/O	General purpose input/output digital pin
			PWM7	I/O	PWM7: PWM output/Capture input
55			PE.0	I/O	General purpose input/output digital pin
			PWM6	I/O	PWM6: PWM output/Capture input
56			PC.13	I/O	General purpose input/output digital pin
			MOSI11	I/O	MOSI11: SPI1 2 <sup>nd</sup> MOSI (Master Out, Slave In) pin
57			PC.12	I/O	General purpose input/output digital pin
			MISO11	I/O	MISO11: SPI1 2 <sup>nd</sup> MISO (Master In, Slave Out) pin
58	33		PC.11	I/O	General purpose input/output digital pin
			MOSI10	I/O	MOSI10: SPI1 MOSI (Master Out, Slave In) pin
59	34		PC.10	I/O	General purpose input/output digital pin
			MISO10	I/O	MISO10: SPI1 MISO (Master In, Slave Out) pin
60	35		PC.9	I/O	General purpose input/output digital pin
			SPICLK1	I/O	SPICLK1: SPI1 serial clock pin
61	36		PC.8	I/O	General purpose input/output digital pin
			SPISS10	I/O	SPISS10: SPI1 slave select pin
62	37	25	PA.15	I/O	General purpose input/output digital pin
			PWM3	I/O	PWM3: PWM output/Capture input
			I2SMCLK	O	I2SMCLK: I <sup>2</sup> S master clock output pin
63	38	26	PA.14	I/O	General purpose input/output digital pin



Pin No.			Pin Name	Pin Type	Description
LQFP 100	LQFP 64	LQFP 48			
			PWM2	I/O	PWM2: PWM output/Capture input
64	39	27	PA.13	I/O	General purpose input/output digital pin
			PWM1	I/O	PWM1: PWM output/Capture input
65	40	28	PA.12	I/O	General purpose input/output digital pin
			PWM0	I/O	PWM0: PWM output/Capture input
66	41	29	ICE_DAT	I/O	Serial Wired Debugger Data pin
67	42	30	ICE_CK	I	Serial Wired Debugger Clock pin
68			V <sub>DD</sub>	P	Power supply for I/O ports and LDO source for internal PLL and digital circuit
69			V <sub>SS</sub>	P	Ground
70	43	31	AV <sub>SS</sub>	AP	Ground Pin for analog circuit
71	44	32	PA.0	I/O	General purpose input/output digital pin
			ADC0	AI	ADC0: ADC analog input
72	45	33	PA.1	I/O	General purpose input/output digital pin
			ADC1	AI	ADC1: ADC analog input
73	46	34	PA.2	I/O	General purpose input/output digital pin
			ADC2	AI	ADC2: ADC analog input
74	47	35	PA.3	I/O	General purpose input/output digital pin
			ADC3	AI	ADC3: ADC analog input
75	48	36	PA.4	I/O	General purpose input/output digital pin
			ADC4	AI	ADC4: ADC analog input
76	49	37	PA.5	I/O	General purpose input/output digital pin
			ADC5	AI	ADC5: ADC analog input
77	50	38	PA.6	I/O	General purpose input/output digital pin
			ADC6	AI	ADC6: ADC analog input
78	51	39	PA.7	I/O	General purpose input/output digital pin
			ADC7	AI	ADC7: ADC analog input
			SPISS21	I/O	SPISS21: SPI2 2 <sup>nd</sup> slave select pin
79			V <sub>ref</sub>	AP	Voltage reference input for ADC
80	52	40	AV <sub>DD</sub>	AP	Power supply for internal analog circuit



Pin No.			Pin Name	Pin Type	Description
LQFP 100	LQFP 64	LQFP 48			
81			PD.0	I/O	General purpose input/output digital pin
			SPISS20	I/O	SPISS20: SPI2 slave select pin
82			PD.1	I/O	General purpose input/output digital pin
			SPICLK2	I/O	SPICLK2: SPI2 serial clock pin
83			PD.2	I/O	General purpose input/output digital pin
			MISO20	I/O	MISO20: SPI2 MISO (Master In, Slave Out) pin
84			PD.3	I/O	General purpose input/output digital pin
			MOSI20	I/O	MOSI20: SPI2 MOSI (Master Out, Slave In) pin
85			PD.4	I/O	General purpose input/output digital pin
			MISO21	I/O	MISO21: SPI2 2 <sup>nd</sup> MISO (Master In, Slave Out) pin
86			PD.5	I/O	General purpose input/output digital pin
			MOSI21	I/O	MOSI21: SPI2 2 <sup>nd</sup> MOSI (Master Out, Slave In) pin
87	53	41	PC.7	I/O	General purpose input/output digital pin
			CPN0	AI	CPN0: Comparator0 Negative input pin
88	54	42	PC.6	I/O	General purpose input/output digital pin
			CPP0	AI	CPP0: Comparator0 Positive input pin
89	55		PC.15	I/O	General purpose input/output digital pin
			CPN1	AI	CPN1: Comparator1 Negative input pin
90	56		PC.14	I/O	General purpose input/output digital pin
			CPP1	AI	CPP1: Comparator1 Positive input pin
91	57	43	PB.15	I/O	General purpose input/output digital pin
			/INT1	I	/INT1: External interrupt0 input pin
92	58	44	XT1_OUT	O	External 4~24 MHz high speed crystal output pin
93	59	45	XT1_IN	I	External 4~24 MHz high speed crystal input pin
94	60	46	/RESET	I	External reset input: Low active, set this pin low reset chip to initial state. With internal pull-up.
95	61		V <sub>SS</sub>	P	Ground
96	62		V <sub>DD</sub>	P	Power supply for I/O ports and LDO source for internal PLL and digital circuit
97			PS2DAT	I/O	PS/2 Data pin



Pin No.			Pin Name	Pin Type		Description
LQFP 100	LQFP 64	LQFP 48				
98			PS2CLK	I/O		PS/2 clock pin
99	63	47	PV <sub>SS</sub>	P		PLL Ground
100	64	48	PB.8	I/O		General purpose input/output digital pin
			STADC	I		STADC: ADC external trigger input.

Note: Pin Type I=Digital Input, O=Digital Output; AI=Analog Input; P=Power Pin; AP=Analog Power





### 3.4.1.2 NuMicro™ NUC120 Medium Density Pin Description

Pin No.			Pin Name	Pin Type	Description
LQFP 100	LQFP 64	LQFP 48			
1			PE.15	I/O	General purpose input/output digital pin
2			PE.14	I/O	General purpose input/output digital pin
3			PE.13	I/O	General purpose input/output digital pin
4	1		PB.14	I/O	General purpose input/output digital pin
			/INT0	I	/INT0: External interrupt1 input pin
			SPISS31	I/O	SPISS31: SPI3 2 <sup>nd</sup> slave select pin
5	2		PB.13	I/O	General purpose input/output digital pin
			CPO1	O	Comparator1 output pin
6	3	1	PB.12	I/O	General purpose input/output digital pin
			CPO0	O	Comparator0 output pin
			CLKO	O	Frequency Divider output pin
7	4	2	X32O	O	External 32.768 kHz low speed crystal output pin
8	5	3	X32I	I	External 32.768 kHz low speed crystal input pin
9	6	4	PA.11	I/O	General purpose input/output digital pin
			I2C1SCL	I/O	I2C1SCL: I <sup>2</sup> C1 clock pin
10	7	5	PA.10	I/O	General purpose input/output digital pin
			I2C1SDA	I/O	I2C1SDA: I <sup>2</sup> C1 data input/output pin
11	8	6	PA.9	I/O	General purpose input/output digital pin
			I2C0SCL	I/O	I2C0SCL: I <sup>2</sup> C0 clock pin
12	9	7	PA.8	I/O	General purpose input/output digital pin
			I2C0SDA	I/O	I2C0SDA: I <sup>2</sup> C0 data input/output pin
13			PD.8	I/O	General purpose input/output digital pin
			SPISS30	I/O	SPISS30: SPI3 slave select pin
14			PD.9	I/O	General purpose input/output digital pin
			SPICLK3	I/O	SPICLK3: SPI3 serial clock pin
15			PD.10	I/O	General purpose input/output digital pin
			MISO30	I/O	MISO30: SPI3 MISO (Master In, Slave Out) pin



Pin No.			Pin Name	Pin Type	Description
LQFP 100	LQFP 64	LQFP 48			
16			PD.11	I/O	General purpose input/output digital pin
			MOSI30	I/O	MOSI30: SPI3 MOSI (Master Out, Slave In) pin
17			PD.12	I/O	General purpose input/output digital pin
			MISO31	I/O	MISO31: SPI3 2 <sup>nd</sup> MISO (Master In, Slave Out) pin
18			PD.13	I/O	General purpose input/output digital pin
			MOSI31	I/O	MOSI31: SPI3 2 <sup>nd</sup> MOSI (Master Out, Slave In) pin
19	10	8	PB.4	I/O	General purpose input/output digital pin
			RXD1	I	RXD1: Data receiver input pin for UART1
20	11	9	PB.5	I/O	General purpose input/output digital pin
			TXD1	O	TXD1: Data transmitter output pin for UART1
21	12		PB.6	I/O	General purpose input/output digital pin
			RTS1	O	RTS1: Request to Send output pin for UART1
22	13		PB.7	I/O	General purpose input/output digital pin
			CTS1	I	CTS1: Clear to Send input pin for UART1
23	14	10	LDO	P	LDO output pin
24	15	11	V <sub>DD</sub>	P	Power supply for I/O ports and LDO source for internal PLL and digital function
25	16	12	V <sub>SS</sub>	P	Ground
26			PE.8	I/O	General purpose input/output digital pin
27			PE.7	I/O	General purpose input/output digital pin
28	17	13	V <sub>BUS</sub>	USB	POWER SUPPLY: From USB Host or HUB.
29	18	14	V <sub>DD33</sub>	USB	Internal Power Regulator Output 3.3 V Decoupling Pin
30	19	15	D-	USB	USB Differential Signal D-
31	20	16	D+	USB	USB Differential Signal D+
32	21	17	PB.0	I/O	General purpose input/output digital pin
			RXD0	I	RXD0: Data receiver input pin for UART0
33	22	18	PB.1	I/O	General purpose input/output digital pin
			TXD0	O	TXD0: Data transmitter output pin for UART0
34	23	19	PB.2	I/O	General purpose input/output digital pin



Pin No.			Pin Name	Pin Type	Description
LQFP 100	LQFP 64	LQFP 48			
			RTS0	O	RTS0: Request to Send output pin for UART0
35	24	20	PB.3	I/O	General purpose input/output digital pin
			CTS0	I	CTS0: Clear to Send input pin for UART0
36			PD.6	I/O	General purpose input/output digital pin
37			PD.7	I/O	General purpose input/output digital pin
38			PD.14	I/O	General purpose input/output digital pin
			RXD2	I	RXD2: Data receiver input pin for UART2
39			PD.15	I/O	General purpose input/output digital pin
			TXD2	O	TXD2: Data transmitter output pin for UART2
40			PC.5	I/O	General purpose input/output digital pin
			MOSI01	I/O	MOSI01: SPI0 2 <sup>nd</sup> MOSI (Master Out, Slave In) pin
41			PC.4	I/O	General purpose input/output digital pin
			MISO01	I/O	MISO01: SPI0 2 <sup>nd</sup> MISO (Master In, Slave Out) pin
42	25	21	PC.3	I/O	General purpose input/output digital pin
			MOSI00	I/O	MOSI00: SPI0 MOSI (Master Out, Slave In) pin
			I2SDO	O	I2SDO: I <sup>2</sup> S data output
43	26	22	PC.2	I/O	General purpose input/output digital pin
			MISO00	I/O	MISO00: SPI0 MISO (Master In, Slave Out) pin
			I2SDI	I	I2SDI: I <sup>2</sup> S data input
44	27	23	PC.1	I/O	General purpose input/output digital pin
			SPICLK0	I/O	SPICLK0: SPI0 serial clock pin
			I2SBCLK	I/O	I2SBCLK: I <sup>2</sup> S bit clock pin
45	28	24	PC.0	I/O	General purpose input/output digital pin
			SPISS00	I/O	SPISS00: SPI0 slave select pin
			I2SLRCLK	I/O	I2SLRCLK: I <sup>2</sup> S left right channel clock
46			PE.6	I/O	General purpose input/output digital pin
47	29		PE.5	I/O	General purpose input/output digital pin
			PWM5	I/O	PWM5: PWM output/Capture input
48	30		PB.11	I/O	General purpose input/output digital pin



Pin No.			Pin Name	Pin Type	Description
LQFP 100	LQFP 64	LQFP 48			
			PWM4	I/O	PWM4: PWM output/Capture input
49	31		PB.10	I/O	General purpose input/output digital pin
			SPISS01	I/O	SPISS01: SPI0 2 <sup>nd</sup> slave select pin
50	32		PB.9	I/O	General purpose input/output digital pin
			SPISS11	I/O	SPISS11: SPI1 2 <sup>nd</sup> slave select pin
51			PE.4	I/O	General purpose input/output digital pin
52			PE.3	I/O	General purpose input/output digital pin
53			PE.2	I/O	General purpose input/output digital pin
54			PE.1	I/O	General purpose input/output digital pin
			PWM7	I/O	PWM7: PWM output/Capture input
55			PE.0	I/O	General purpose input/output digital pin
			PWM6	I/O	PWM6: PWM output/Capture input
56			PC.13	I/O	General purpose input/output digital pin
			MOSI11	I/O	MOSI11: SPI1 2 <sup>nd</sup> MOSI (Master Out, Slave In) pin
57			PC.12	I/O	General purpose input/output digital pin
			MISO11	I/O	MISO11: SPI1 2 <sup>nd</sup> MISO (Master In, Slave Out) pin
58	33		PC.11	I/O	General purpose input/output digital pin
			MOSI10	I/O	MOSI10: SPI1 MOSI (Master Out, Slave In) pin
59	34		PC.10	I/O	General purpose input/output digital pin
			MISO10	I/O	MISO10: SPI1 MISO (Master In, Slave Out) pin
60	35		PC.9	I/O	General purpose input/output digital pin
			SPICLK1	I/O	SPICLK1: SPI1 serial clock pin
61	36		PC.8	I/O	General purpose input/output digital pin
			SPISS10	I/O	SPISS10: SPI1 slave select pin
62	37	25	PA.15	I/O	General purpose input/output digital pin
			PWM3	I/O	PWM3: PWM output/Capture input
			I2SMCLK	O	I2SMCLK: I <sup>2</sup> S master clock output pin
63	38	26	PA.14	I/O	General purpose input/output digital pin
			PWM2	I/O	PWM2: PWM output/Capture input



Pin No.			Pin Name	Pin Type	Description
LQFP 100	LQFP 64	LQFP 48			
64	39	27	PA.13	I/O	General purpose input/output digital pin
			PWM1	I/O	PWM1: PWM output/Capture input
65	40	28	PA.12	I/O	General purpose input/output digital pin
			PWM0	I/O	PWM0: PWM output/Capture input
66	41	29	ICE_DAT	I/O	Serial Wired Debugger Data pin
67	42	30	ICE_CK	I	Serial Wired Debugger Clock pin
68			V <sub>DD</sub>	P	Power supply for I/O ports and LDO source for internal PLL and digital circuit
69			V <sub>SS</sub>	P	Ground
70	43	31	AV <sub>SS</sub>	AP	Ground Pin for analog circuit
71	44	32	PA.0	I/O	General purpose input/output digital pin
			ADC0	AI	ADC0: ADC analog input
72	45	33	PA.1	I/O	General purpose input/output digital pin
			ADC1	AI	ADC1: ADC analog input
73	46	34	PA.2	I/O	General purpose input/output digital pin
			ADC2	AI	ADC2: ADC analog input
74	47	35	PA.3	I/O	General purpose input/output digital pin
			ADC3	AI	ADC3: ADC analog input
75	48	36	PA.4	I/O	General purpose input/output digital pin
			ADC4	AI	ADC4: ADC analog input
76	49	37	PA.5	I/O	General purpose input/output digital pin
			ADC5	AI	ADC5: ADC analog input
77	50	38	PA.6	I/O	General purpose input/output digital pin
			ADC6	AI	ADC6: ADC analog input
78	51	39	PA.7	I/O	General purpose input/output digital pin
			ADC7	AI	ADC7: ADC analog input
			SPISS21	I/O	SPISS21: SPI2 2 <sup>nd</sup> slave select pin
79			V <sub>ref</sub>	AP	Voltage reference input for ADC
80	52	40	AV <sub>DD</sub>	AP	Power supply for internal analog circuit
81			PD.0	I/O	General purpose input/output digital pin



Pin No.			Pin Name	Pin Type	Description
LQFP 100	LQFP 64	LQFP 48			
			SPISS20	I/O	SPISS20: SPI2 slave select pin
82			PD.1	I/O	General purpose input/output digital pin
			SPICLK2	I/O	SPICLK2: SPI2 serial clock pin
83			PD.2	I/O	General purpose input/output digital pin
			MISO20	I/O	MISO20: SPI2 MISO (Master In, Slave Out) pin
84			PD.3	I/O	General purpose input/output digital pin
			MOSI20	I/O	MOSI20: SPI2 MOSI (Master Out, Slave In) pin
85			PD.4	I/O	General purpose input/output digital pin
			MISO21	I/O	MISO21: SPI2 2 <sup>nd</sup> MISO (Master In, Slave Out) pin
86			PD.5	I/O	General purpose input/output digital pin
			MOSI21	I/O	MOSI21: SPI2 2 <sup>nd</sup> MOSI (Master Out, Slave In) pin
87	53	41	PC.7	I/O	General purpose input/output digital pin
			CPN0	AI	CPN0: Comparator0 Negative input pin
88	54	42	PC.6	I/O	General purpose input/output digital pin
			CPP0	AI	CPP0: Comparator0 Positive input pin
89	55		PC.15	I/O	General purpose input/output digital pin
			CPN1	AI	CPN1: Comparator1 Negative input pin
90	56		PC.14	I/O	General purpose input/output digital pin
			CPP1	AI	CPP1: Comparator1 Positive input pin
91	57	43	PB.15	I/O	General purpose input/output digital pin
			/INT1	I	/INT1: External interrupt0 input pin
92	58	44	XT1_OUT	O	External 4~24 MHz high speed crystal output pin
93	59	45	XT1_IN	I	External 4~24 MHz high speed crystal input pin
94	60	46	/RESET	I	External reset input: Low active, set this pin low reset chip to initial state. With internal pull-up.
95	61		V <sub>SS</sub>	P	Ground
96	62		V <sub>DD</sub>	P	Power supply for I/O ports and LDO source for internal PLL and digital circuit
97			PS2DAT	I/O	PS/2 Data pin
98			PS2CLK	I/O	PS/2 clock pin



Pin No.			Pin Name	Pin Type		Description
LQFP 100	LQFP 64	LQFP 48				
99	63	47	PV <sub>SS</sub>	<b>P</b>		PLL Ground
100	64	48	PB.8	<b>I/O</b>		General purpose input/output digital pin
			STADC	<b>I</b>		STADC: ADC external trigger input.

Note: Pin Type I=Digital Input, O=Digital Output; AI=Analog Input; P=Power Pin; AP=Analog Power



## 3.4.2 NuMicro™ NUC100/NUC120 Low Density Pin Description

### 3.4.2.1 NuMicro™ NUC100 Low Density Pin Description

Pin No.		Pin Name	Pin Type		Description
LQFP 64	LQFP 48				
1		PB.14	I/O		General purpose input/output digital pin
		/INT0	I		/INT0: External interrupt1 input pin
2		PB.13	I/O		General purpose input/output digital pin
		CPO1	O		Comparator1 output pin
		AD1	I/O		EBI Address/Data bus bit1 (64pin package only)
3	1	PB.12	I/O		General purpose input/output digital pin
		CPO0	O		Comparator0 output pin
		CLKO	O		Frequency Divider output pin
		AD0	I/O		EBI Address/Data bus bit0 (64pin package only)
4	2	X32O	O		External 32.768 kHz low speed crystal output pin
5	3	X32I	I		External 32.768 kHz low speed crystal input pin
6	4	PA.11	I/O		General purpose input/output digital pin
		I2C1SCL	I/O		I2C1SCL: I <sup>2</sup> C1 clock pin
		nRD	O		EBI read enable output pin (64pin package only)
7	5	PA.10	I/O		General purpose input/output digital pin
		I2C1SDA	I/O		I2C1SDA: I <sup>2</sup> C1 data input/output pin
		nWR	O		EBI write enable output pin (64pin package only)
8	6	PA.9	I/O		General purpose input/output digital pin
		I2C0SCL	I/O		I2C0SCL: I <sup>2</sup> C0 clock pin
9	7	PA.8	I/O		General purpose input/output digital pin
		I2C0SDA	I/O		I2C0SDA: I <sup>2</sup> C0 data input/output pin
10	8	PB.4	I/O		General purpose input/output digital pin
		RXD1	I		RXD1: Data receiver input pin for UART1
11	9	PB.5	I/O		General purpose input/output digital pin
		TXD1	O		TXD1: Data transmitter output pin for UART1
12		PB.6	I/O		General purpose input/output digital pin





Pin No.		Pin Name	Pin Type		Description
LQFP 64	LQFP 48				
		RTS1	O		RTS1: Request to Send output pin for UART1
		ALE	O		EBI address latch enable output pin (64pin package only)
13		PB.7	I/O		General purpose input/output digital pin
		CTS1	I		CTS1: Clear to Send input pin for UART1
		nCS	O		EBI chip select enable output pin (64pin package only)
14	10	LDO	P		LDO output pin
15	11	V <sub>DD</sub>	P		Power supply for I/O ports and LDO source for internal PLL and digital function
16	12	V <sub>SS</sub>	P		Ground
17	13	PB.0	I/O		General purpose input/output digital pin
		RXD0	I		RXD0: Data receiver input pin for UART0
18	14	PB.1	I/O		General purpose input/output digital pin
		TXD0	O		TXD0: Data transmitter output pin for UART0
19	15	PB.2	I/O		General purpose input/output digital pin
		RTS0	O		RTS0: Request to Send output pin for UART0
		nWRL	O		EBI low byte write enable output pin (64pin package only)
20	16	PB.3	I/O		General purpose input/output digital pin
		CTS0	I		CTS0: Clear to Send input pin for UART0
		nWRH	O		EBI high byte write enable output pin (64pin package only)
21		PD.6	I/O		General purpose input/output digital pin
22		PD.7	I/O		General purpose input/output digital pin
23		PD.14	I/O		General purpose input/output digital pin
24		PD.15	I/O		General purpose input/output digital pin
25	17	PC.3	I/O		General purpose input/output digital pin
		MOSI00	I/O		MOSI00: SPI0 MOSI (Master Out, Slave In) pin
		I2SDO	O		I2SDO: I <sup>2</sup> S data output
26	18	PC.2	I/O		General purpose input/output digital pin
		MISO00	I/O		MISO00: SPI0 MISO (Master In, Slave Out) pin



Pin No.		Pin Name	Pin Type	Description
LQFP 64	LQFP 48			
		I2SDI	I	I2SDI: I <sup>2</sup> S data input
27	19	PC.1	I/O	General purpose input/output digital pin
		SPICLK0	I/O	SPICLK0: SPI0 serial clock pin
		I2SBCLK	I/O	I2SBCLK: I <sup>2</sup> S bit clock pin
28	20	PC.0	I/O	General purpose input/output digital pin
		SPISS00	I/O	SPISS00: SPI0 slave select pin
		I2SLRCLK	I/O	I2SLRCLK: I <sup>2</sup> S left right channel clock
29	21	PE.5	I/O	General purpose input/output digital pin
30	22	PB.11	I/O	General purpose input/output digital pin
		TM3	I/O	TM3: Timer3 event counter input / toggle output
31	23	PB.10	I/O	General purpose input/output digital pin
		TM2	I/O	TM2: Timer2 event counter input / toggle output
32	24	PB.9	I/O	General purpose input/output digital pin
		TM1	I/O	TM1: Timer1 event counter input / toggle output
33		PC.11	I/O	General purpose input/output digital pin
		MOSI10	I/O	MOSI10: SPI1 MOSI (Master Out, Slave In) pin
34		PC.10	I/O	General purpose input/output digital pin
		MISO10	I/O	MISO10: SPI1 MISO (Master In, Slave Out) pin
35		PC.9	I/O	General purpose input/output digital pin
		SPICLK1	I/O	SPICLK1: SPI1 serial clock pin
36		PC.8	I/O	General purpose input/output digital pin
		SPISS10	I/O	SPISS10: SPI1 slave select pin
		MCLK	O	EBI external clock output pin (64pin package only)
37	25	PA.15	I/O	General purpose input/output digital pin
		PWM3	I/O	PWM3: PWM output/Capture input
		I2SMCLK	O	I2SMCLK: I <sup>2</sup> S master clock output pin
38	26	PA.14	I/O	General purpose input/output digital pin
		PWM2	I/O	PWM2: PWM output/Capture input
			AD15	I/O



Pin No.		Pin Name	Pin Type		Description
LQFP 64	LQFP 48				
39	27	PA.13	I/O		General purpose input/output digital pin
		PWM1	I/O		PWM1: PWM output/Capture input
		AD14	I/O		EBI Address/Data bus bit14 (64pin package only)
40	28	PA.12	I/O		General purpose input/output digital pin
		PWM0	I/O		PWM0: PWM output/Capture input
		AD13	I/O		EBI Address/Data bus bit13 (64pin package only)
41	29	ICE_DAT	I/O		Serial Wired Debugger Data pin
42	30	ICE_CK	I		Serial Wired Debugger Clock pin
43	31	AV <sub>SS</sub>	AP		Ground Pin for analog circuit
44	32	PA.0	I/O		General purpose input/output digital pin
		ADC0	AI		ADC0: ADC analog input
45	33	PA.1	I/O		General purpose input/output digital pin
		ADC1	AI		ADC1: ADC analog input
		AD12	I/O		EBI Address/Data bus bit12 (64pin package only)
46	34	PA.2	I/O		General purpose input/output digital pin
		ADC2	AI		ADC2: ADC analog input
		AD11	I/O		EBI Address/Data bus bit11 (64pin package only)
47	35	PA.3	I/O		General purpose input/output digital pin
		ADC3	AI		ADC3: ADC analog input
		AD10	I/O		EBI Address/Data bus bit10 (64pin package only)
48	36	PA.4	I/O		General purpose input/output digital pin
		ADC4	AI		ADC4: ADC analog input
		AD9	I/O		EBI Address/Data bus bit9 (64pin package only)
49	37	PA.5	I/O		General purpose input/output digital pin
		ADC5	AI		ADC5: ADC analog input
		AD8	I/O		EBI Address/Data bus bit8 (64pin package only)
50	38	PA.6	I/O		General purpose input/output digital pin
		ADC6	AI		ADC6: ADC analog input
		AD7	I/O		EBI Address/Data bus bit7 (64pin package only)



Pin No.		Pin Name	Pin Type		Description
LQFP 64	LQFP 48				
51	39	PA.7	I/O		General purpose input/output digital pin
		ADC7	AI		ADC7: ADC analog input
		AD6	I/O		EBI Address/Data bus bit6 (64pin package only)
52	40	AV <sub>DD</sub>	AP		Power supply for internal analog circuit
53	41	PC.7	I/O		General purpose input/output digital pin
		CPN0	AI		CPN0: Comparator0 Negative input pin
		AD5	I/O		EBI Address/Data bus bit5 (64pin package only)
54	42	PC.6	I/O		General purpose input/output digital pin
		CPP0	AI		CPP0: Comparator0 Positive input pin
		AD4	I/O		EBI Address/Data bus bit4 (64pin package only)
55		PC.15	I/O		General purpose input/output digital pin
		CPN1	AI		CPN1: Comparator1 Negative input pin
		AD3	I/O		EBI Address/Data bus bit3 (64pin package only)
56		PC.14	I/O		General purpose input/output digital pin
		CPP1	AI		CPP1: Comparator1 Positive input pin
		AD2	I/O		EBI Address/Data bus bit2 (64pin package only)
57	43	PB.15	I/O		General purpose input/output digital pin
		/INT1	I		/INT1: External interrupt0 input pin
58	44	XT1_OUT	O		External 4~24 MHz high speed crystal output pin
59	45	XT1_IN	I		External 4~24 MHz high speed crystal input pin
60	46	/RESET	I		External reset input: Low active, set this pin low reset chip to initial state. With internal pull-up.
61		V <sub>SS</sub>	P		Ground
62		V <sub>DD</sub>	P		Power supply for I/O ports and LDO source for internal PLL and digital circuit
63	47	PV <sub>SS</sub>	P		PLL Ground
64	48	PB.8	I/O		General purpose input/output digital pin
		STADC	I		STADC: ADC external trigger input.
		TM0	I/O		TM0: Timer0 event counter input / toggle output

Note: Pin Type I=Digital Input, O=Digital Output; AI=Analog Input; P=Power Pin; AP=Analog Power



### 3.4.2.2 NuMicro™ NUC120 Low Density Pin Description

Pin No.		Pin Name	Pin Type		Description
LQFP 64	LQFP 48				
1		PB.14	I/O		General purpose input/output digital pin
		/INT0	I		/INT0: External interrupt1 input pin
2		PB.13	I/O		General purpose input/output digital pin
		CPO1	O		Comparator1 output pin
		AD1	I/O		EBI Address/Data bus bit1 (64pin package only)
3	1	PB.12	I/O		General purpose input/output digital pin
		CPO0	O		Comparator0 output pin
		CLKO	O		Frequency Divider output pin
		AD0	I/O		EBI Address/Data bus bit0 (64pin package only)
4	2	X32O	O		External 32.768 kHz low speed crystal output pin
5	3	X32I	I		External 32.768 kHz low speed crystal input pin
6	4	PA.11	I/O		General purpose input/output digital pin
		I2C1SCL	I/O		I2C1SCL: I <sup>2</sup> C1 clock pin
		nRD	O		EBI read enable output pin (64pin package only)
7	5	PA.10	I/O		General purpose input/output digital pin
		I2C1SDA	I/O		I2C1SDA: I <sup>2</sup> C1 data input/output pin
		nWR	O		EBI write enable output pin (64pin package only)
8	6	PA.9	I/O		General purpose input/output digital pin
		I2C0SCL	I/O		I2C0SCL: I <sup>2</sup> C0 clock pin
9	7	PA.8	I/O		General purpose input/output digital pin
		I2C0SDA	I/O		I2C0SDA: I <sup>2</sup> C0 data input/output pin
10	8	PB.4	I/O		General purpose input/output digital pin
		RXD1	I		RXD1: Data receiver input pin for UART1
11	9	PB.5	I/O		General purpose input/output digital pin
		TXD1	O		TXD1: Data transmitter output pin for UART1
12		PB.6	I/O		General purpose input/output digital pin
		RTS1	O		RTS1: Request to Send output pin for UART1



Pin No.		Pin Name	Pin Type		Description
LQFP 64	LQFP 48				
		ALE	O		EBI address latch enable output pin (64pin package only)
13		PB.7	I/O		General purpose input/output digital pin
		CTS1	I		CTS1: Clear to Send input pin for UART1
		nCS	O		EBI chip select enable output pin (64pin package only)
14	10	LDO	P		LDO output pin
15	11	V <sub>DD</sub>	P		Power supply for I/O ports and LDO source for internal PLL and digital function
16	12	V <sub>SS</sub>	P		Ground
17	13	V <sub>BUS</sub>	USB		POWER SUPPLY: From USB Host or HUB.
18	14	V <sub>DD33</sub>	USB		Internal Power Regulator Output 3.3 V Decoupling Pin
19	15	D-	USB		USB Differential Signal D-
20	16	D+	USB		USB Differential Signal D+
21	17	PB.0	I/O		General purpose input/output digital pin
		RXD0	I		RXD0: Data receiver input pin for UART0
22	18	PB.1	I/O		General purpose input/output digital pin
		TXD0	O		TXD0: Data transmitter output pin for UART0
23	19	PB.2	I/O		General purpose input/output digital pin
		RTS0	O		RTS0: Request to Send output pin for UART0
	nWRL	O		EBI low byte write enable output pin (64pin package only)	
24	20	PB.3	I/O		General purpose input/output digital pin
		CTS0	I		CTS0: Clear to Send input pin for UART0
	nWRH	O		EBI high byte write enable output pin (64pin package only)	
25	21	PC.3	I/O		General purpose input/output digital pin
		MOSI00	I/O		MOSI00: SPI0 MOSI (Master Out, Slave In) pin
		I2SDO	O		I2SDO: I <sup>2</sup> S data output
26	22	PC.2	I/O		General purpose input/output digital pin
		MISO00	I/O		MISO00: SPI0 MISO (Master In, Slave Out) pin



Pin No.		Pin Name	Pin Type		Description
LQFP 64	LQFP 48				
		I2SDI	I		I2SDI: I <sup>2</sup> S data input
27	23	PC.1	I/O		General purpose input/output digital pin
		SPICLK0	I/O		SPICLK0: SPI0 serial clock pin
		I2SBCLK	I/O		I2SBCLK: I <sup>2</sup> S bit clock pin
28	24	PC.0	I/O		General purpose input/output digital pin
		SPISS00	I/O		SPISS00: SPI0 slave select pin
		I2SLRCLK	I/O		I2SLRCLK: I <sup>2</sup> S left right channel clock
29		PE.5	I/O		General purpose input/output digital pin
30		PB.11	I/O		General purpose input/output digital pin
		TM3	I/O		TM3: Timer3 event counter input / toggle output
31		PB.10	I/O		General purpose input/output digital pin
		TM2	I/O		TM2: Timer2 event counter input / toggle output
32		PB.9	I/O		General purpose input/output digital pin
		TM1	I/O		TM1: Timer1 event counter input / toggle output
33		PC.11	I/O		General purpose input/output digital pin
		MOSI10	I/O		MOSI10: SPI1 MOSI (Master Out, Slave In) pin
34		PC.10	I/O		General purpose input/output digital pin
		MISO10	I/O		MISO10: SPI1 MISO (Master In, Slave Out) pin
35		PC.9	I/O		General purpose input/output digital pin
		SPICLK1	I/O		SPICLK1: SPI1 serial clock pin
36		PC.8	I/O		General purpose input/output digital pin
		SPISS10	I/O		SPISS10: SPI1 slave select pin
		MCLK	O		EBI external clock output pin (64pin package only)
37	25	PA.15	I/O		General purpose input/output digital pin
		PWM3	I/O		PWM3: PWM output/Capture input
		I2SMCLK	O		I2SMCLK: I <sup>2</sup> S master clock output pin
38	26	PA.14	I/O		General purpose input/output digital pin
		PWM2	I/O		PWM2: PWM output/Capture input
			AD15	I/O	



Pin No.		Pin Name	Pin Type		Description
LQFP 64	LQFP 48				
39	27	PA.13	I/O		General purpose input/output digital pin
		PWM1	I/O		PWM1: PWM output/Capture input
		AD14	I/O		EBI Address/Data bus bit14 (64pin package only)
40	28	PA.12	I/O		General purpose input/output digital pin
		PWM0	I/O		PWM0: PWM output/Capture input
		AD13	I/O		EBI Address/Data bus bit13 (64pin package only)
41	29	ICE_DAT	I/O		Serial Wired Debugger Data pin
42	30	ICE_CK	I		Serial Wired Debugger Clock pin
43	31	AV <sub>SS</sub>	AP		Ground Pin for analog circuit
44	32	PA.0	I/O		General purpose input/output digital pin
		ADC0	AI		ADC0: ADC analog input
45	33	PA.1	I/O		General purpose input/output digital pin
		ADC1	AI		ADC1: ADC analog input
		AD12	I/O		EBI Address/Data bus bit12 (64pin package only)
46	34	PA.2	I/O		General purpose input/output digital pin
		ADC2	AI		ADC2: ADC analog input
		AD11	I/O		EBI Address/Data bus bit11 (64pin package only)
47	35	PA.3	I/O		General purpose input/output digital pin
		ADC3	AI		ADC3: ADC analog input
		AD10	I/O		EBI Address/Data bus bit10 (64pin package only)
48	36	PA.4	I/O		General purpose input/output digital pin
		ADC4	AI		ADC4: ADC analog input
		AD9	I/O		EBI Address/Data bus bit9 (64pin package only)
49	37	PA.5	I/O		General purpose input/output digital pin
		ADC5	AI		ADC5: ADC analog input
		AD8	I/O		EBI Address/Data bus bit8 (64pin package only)
50	38	PA.6	I/O		General purpose input/output digital pin
		ADC6	AI		ADC6: ADC analog input
		AD7	I/O		EBI Address/Data bus bit7 (64pin package only)





Pin No.		Pin Name	Pin Type		Description
LQFP 64	LQFP 48				
51	39	PA.7	I/O		General purpose input/output digital pin
		ADC7	AI		ADC7: ADC analog input
		AD6	I/O		EBI Address/Data bus bit6 (64pin package only)
52	40	AV <sub>DD</sub>	AP		Power supply for internal analog circuit
53	41	PC.7	I/O		General purpose input/output digital pin
		CPN0	AI		CPN0: Comparator0 Negative input pin
		AD5	I/O		EBI Address/Data bus bit5 (64pin package only)
54	42	PC.6	I/O		General purpose input/output digital pin
		CPP0	AI		CPP0: Comparator0 Positive input pin
		AD4	I/O		EBI Address/Data bus bit4 (64pin package only)
55		PC.15	I/O		General purpose input/output digital pin
		CPN1	AI		CPN1: Comparator1 Negative input pin
		AD3	I/O		EBI Address/Data bus bit3 (64pin package only)
56		PC.14	I/O		General purpose input/output digital pin
		CPP1	AI		CPP1: Comparator1 Positive input pin
		AD2	I/O		EBI Address/Data bus bit2 (64pin package only)
57	43	PB.15	I/O		General purpose input/output digital pin
		/INT1	I		/INT1: External interrupt0 input pin
58	44	XT1_OUT	O		External 4~24 MHz high speed crystal output pin
59	45	XT1_IN	I		External 4~24 MHz high speed crystal input pin
60	46	/RESET	I		External reset input: Low active, set this pin low reset chip to initial state. With internal pull-up.
61		V <sub>SS</sub>	P		Ground
62		V <sub>DD</sub>	P		Power supply for I/O ports and LDO source for internal PLL and digital circuit
63	47	PV <sub>SS</sub>	P		PLL Ground
64	48	PB.8	I/O		General purpose input/output digital pin
		STADC	I		STADC: ADC external trigger input.
		TM0	I/O		TM0: Timer0 event counter input / toggle output

Note: Pin Type I=Digital Input, O=Digital Output; AI=Analog Input; P=Power Pin; AP=Analog Power

## 4 BLOCK DIAGRAM

### 4.1 NuMicro™ NUC100/NUC120 Medium Density Block Diagram

#### 4.1.1 NuMicro™ NUC100 Medium Density Block Diagram

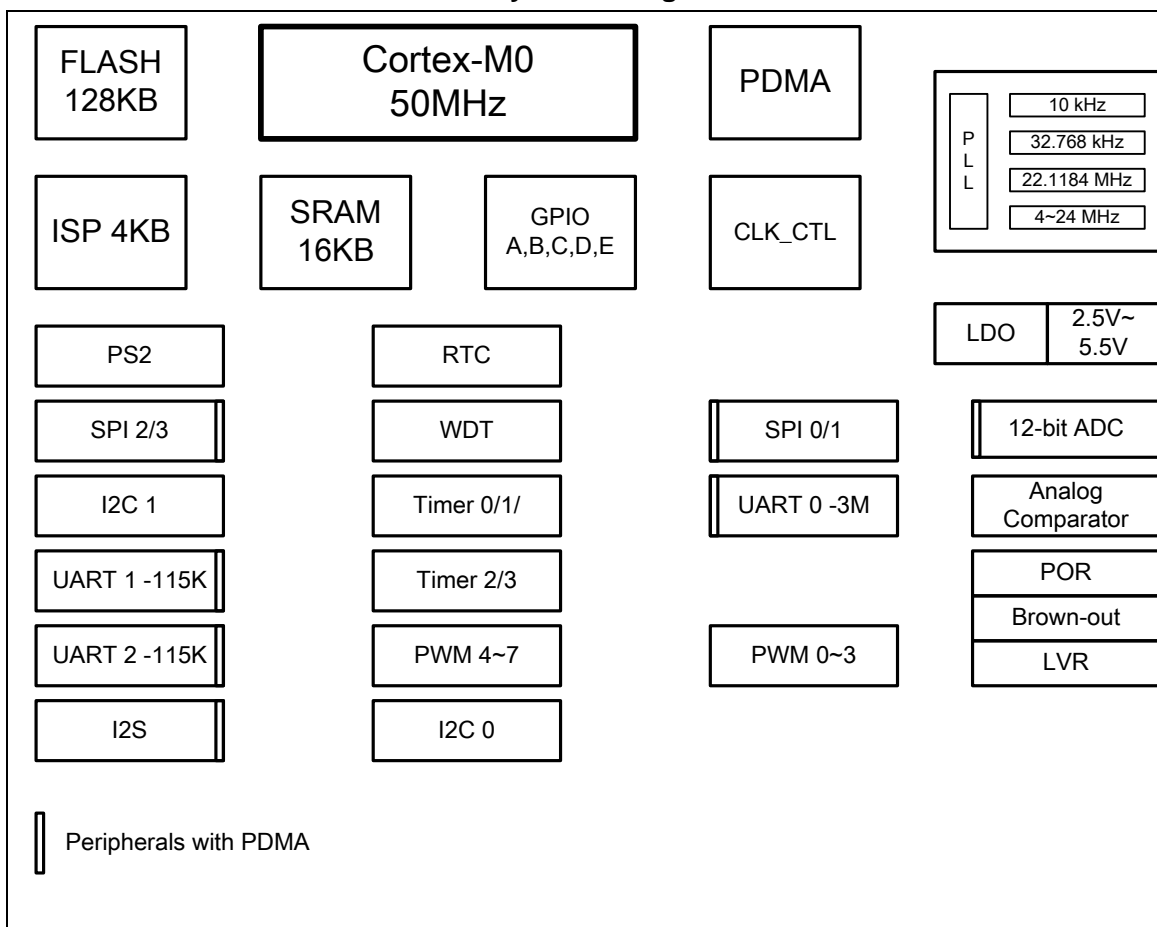

Figure 4-1 NuMicro™ NUC100 Medium Density Block Diagram

## 4.1.2 NuMicro™ NUC120 Medium Density Block Diagram

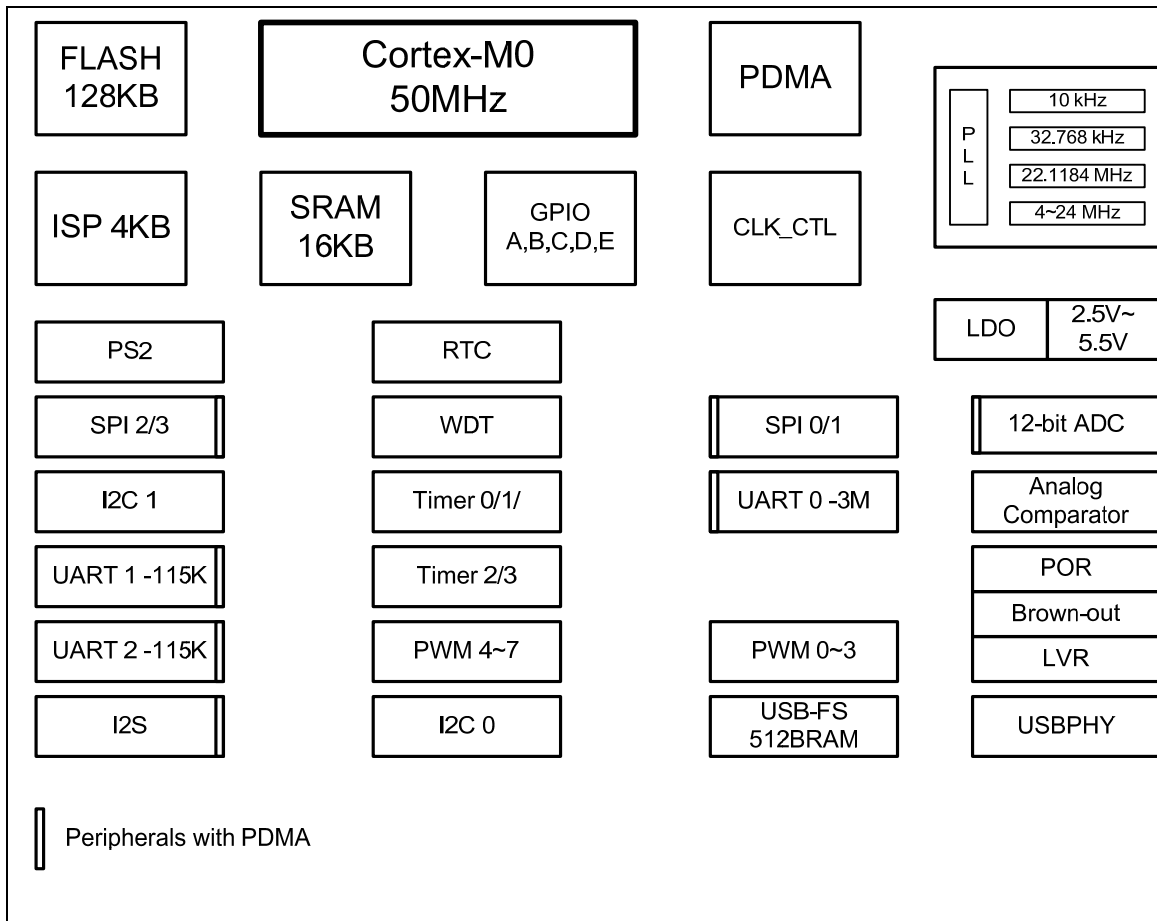

Figure 4-2 NuMicro™ NUC120 Medium Density Block Diagram

## 4.2 NuMicro™ NUC100/NUC120 Low Density Block Diagram

### 4.2.1 NuMicro™ NUC100 Low Density Block Diagram

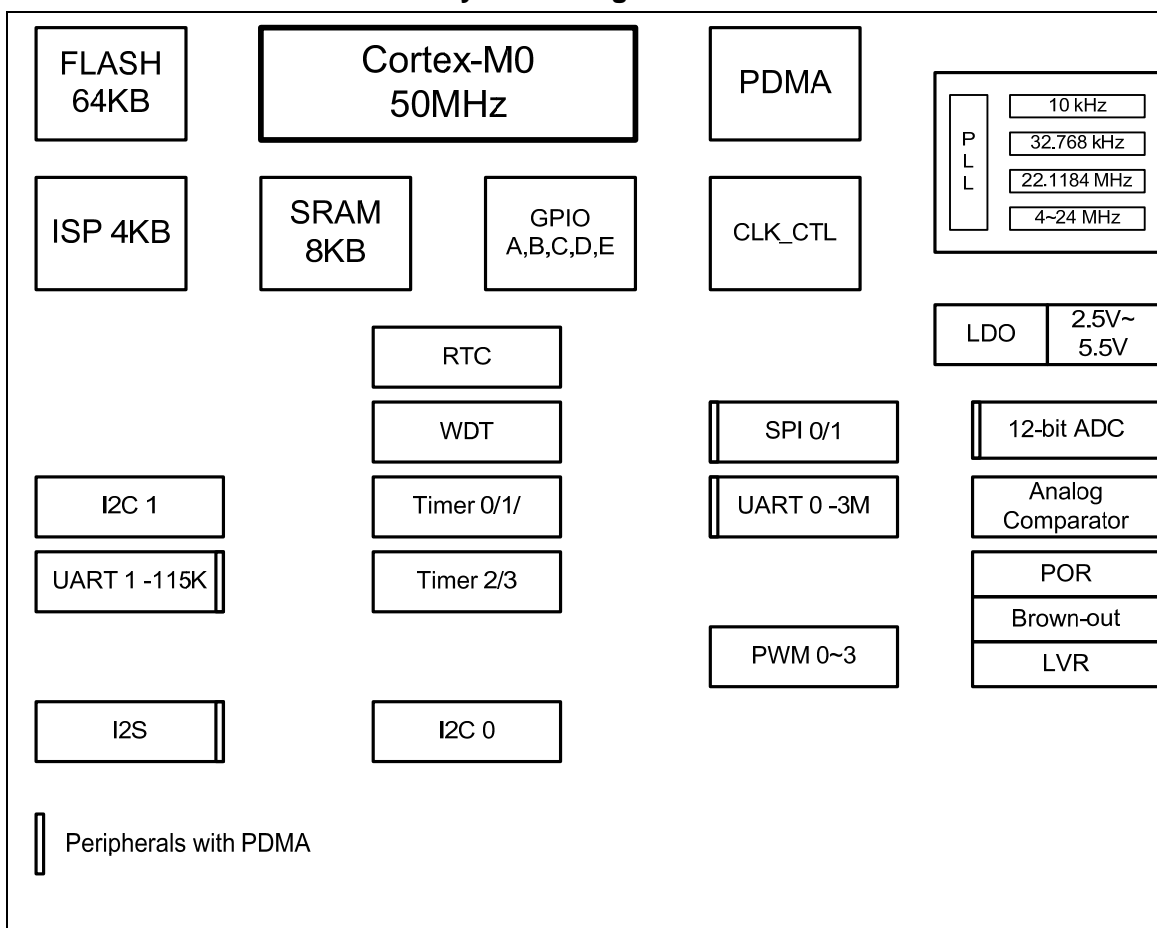

Figure 4-3 NuMicro™ NUC100 Low Density Block Diagram

## 4.2.2 NuMicro™ NUC120 Low Density Block Diagram

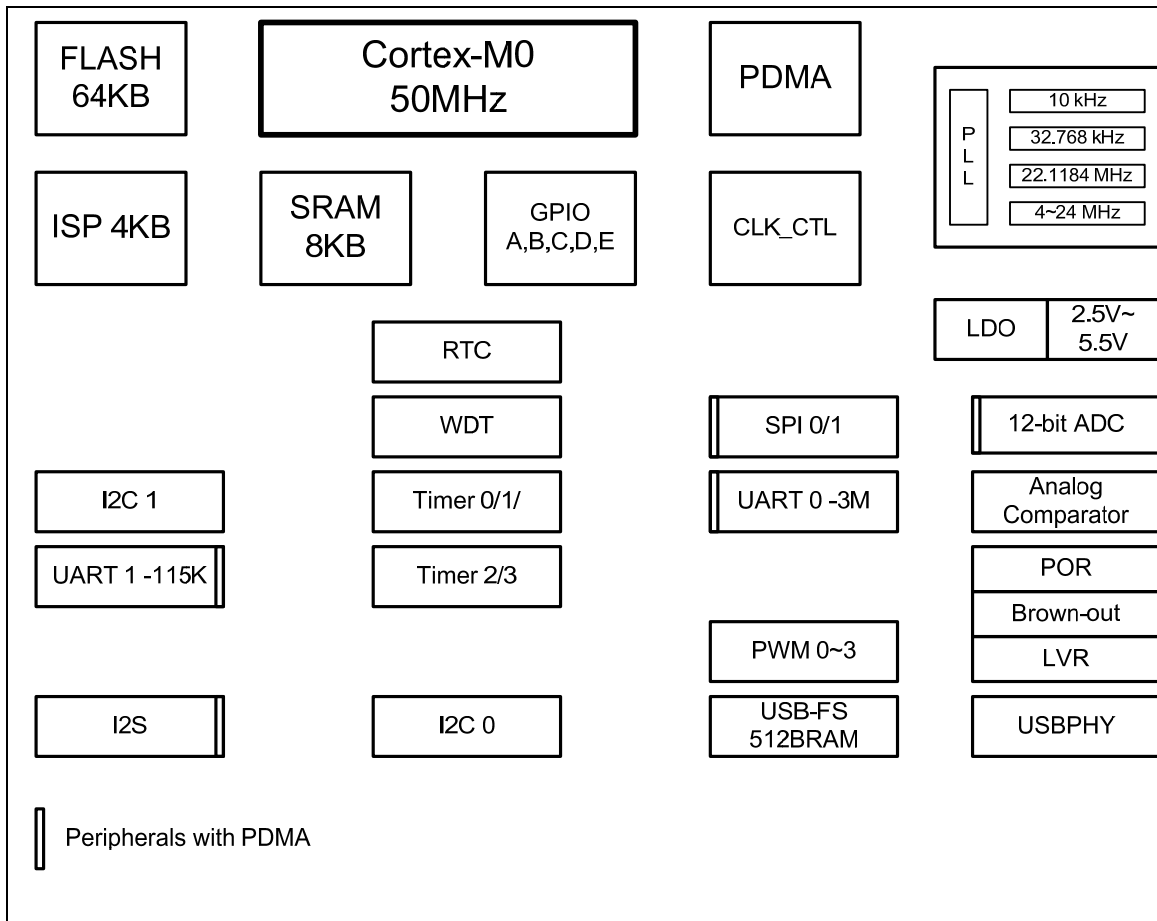

Figure 4-4 NuMicro™ NUC120 Low Density Block Diagram

## 5 FUNCTIONAL DESCRIPTION

### 5.1 ARM® Cortex™-M0 Core

The Cortex™-M0 processor is a configurable, multistage, 32-bit RISC processor. It has an AMBA AHB-Lite interface and includes an NVIC component. It also has optional hardware debug functionality. The processor can execute Thumb code and is compatible with other Cortex-M profile processor. The profile supports two modes -Thread mode and Handler mode. Handler mode is entered as a result of an exception. An exception return can only be issued in Handler mode. Thread mode is entered on Reset, and can be entered as a result of an exception return. Figure 5-1 shows the functional controller of processor.

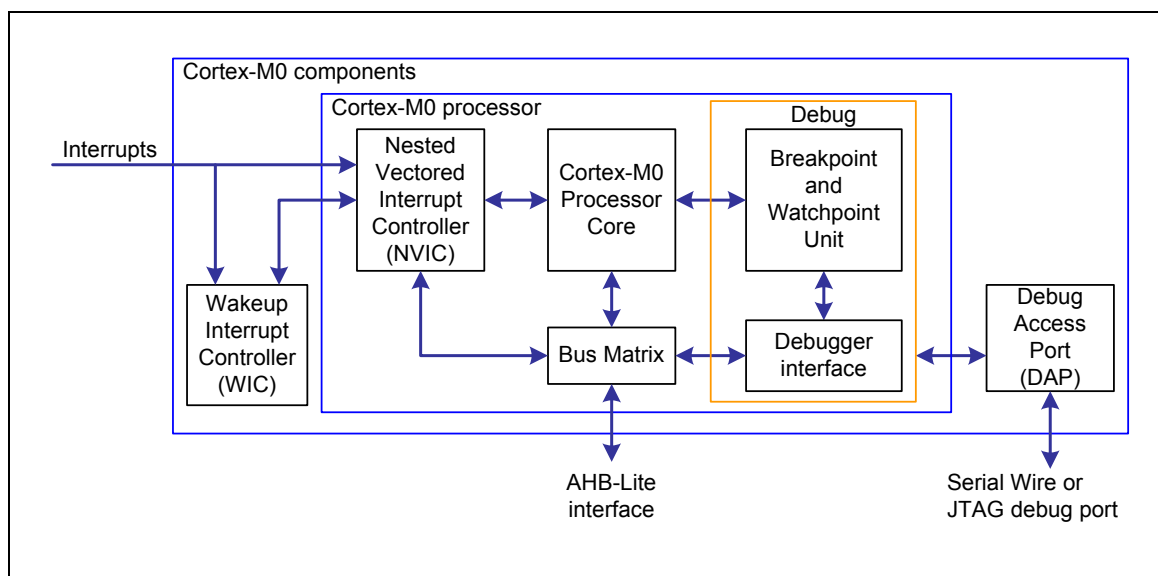

Figure 5-1 Functional Controller Diagram

The implemented device provides:

- A low gate count processor that features:
  - ◆ The ARMv6-M Thumb® instruction set
  - ◆ Thumb-2 technology
  - ◆ ARMv6-M compliant 24-bit SysTick timer
  - ◆ A 32-bit hardware multiplier
  - ◆ The system interface supports little-endian data accesses
  - ◆ The ability to have deterministic, fixed-latency, interrupt handling
  - ◆ Load/store-multiples and multicycle-multiplies that can be abandoned and restarted to facilitate rapid interrupt handling
  - ◆ C Application Binary Interface compliant exception model. This is the ARMv6-M, C Application Binary Interface (C-ABI) compliant exception model that enables the use of pure C functions as interrupt handlers



- ◆ Low power sleep mode entry using Wait For Interrupt (WFI), Wait For Event (WFE) instructions, or the return from interrupt sleep-on-exit feature
- NVIC that features:
  - ◆ 32 external interrupt inputs, each with four levels of priority
  - ◆ Dedicated Non-Maskable Interrupt (NMI) input.
  - ◆ Support for both level-sensitive and pulse-sensitive interrupt lines
  - ◆ Wake-up Interrupt Controller (WIC), providing ultra-low power sleep mode support.
- Debug support
  - ◆ Four hardware breakpoints.
  - ◆ Two watchpoints.
  - ◆ Program Counter Sampling Register (PCSR) for non-intrusive code profiling.
  - ◆ Single step and vector catch capabilities.
- Bus interfaces:
  - ◆ Single 32-bit AMBA-3 AHB-Lite system interface that provides simple integration to all system peripherals and memory.
  - ◆ Single 32-bit slave port that supports the DAP (Debug Access Port).

## 5.2 System Manager

### 5.2.1 Overview

System management includes these following sections:

- System Resets
- System Memory Map
- System management registers for Part Number ID, chip reset and on-chip controllers reset , multi-functional pin control
- System Timer (SysTick)
- Nested Vectored Interrupt Controller (NVIC)
- System Control registers

### 5.2.2 System Reset

The system reset can be issued by one of the below listed events. For these reset event flags can be read by RSTSRC register.

- The Power-On Reset
- The low level on the /RESET pin
- Watchdog Time Out Reset
- Low Voltage Reset
- Brown-Out Detector Reset
- CPU Reset
- System Reset

System Reset and Power-On Reset all reset the whole chip including all peripherals. The difference between System Reset and Power-On Reset is external crystal circuit and ISPCON.BS bit. System Reset doesn't reset external crystal circuit and ISPCON.BS bit, but Power-On Reset does.



## 5.2.3 System Power Distribution

In this chip, the power distribution is divided into three segments.

- Analog power from  $AV_{DD}$  and  $AV_{SS}$  provides the power for analog components operation.
- Digital power from  $V_{DD}$  and  $V_{SS}$  supplies the power to the internal regulator which provides a fixed 2.5 V power for digital operation and I/O pins.
- USB transceiver power from  $V_{BUS}$  offers the power for operating the USB transceiver. (For NuMicro™ NUC120 only)

The outputs of internal voltage regulators, LDO and  $V_{DD33}$ , require an external capacitor which should be located close to the corresponding pin. Analog power ( $AV_{DD}$ ) should be the same voltage level of the digital power ( $V_{DD}$ ). Figure 5-2 shows the power distribution of NuMicro™ NUC120 and Figure 5-3 shows the power distribution of NuMicro™ NUC100.

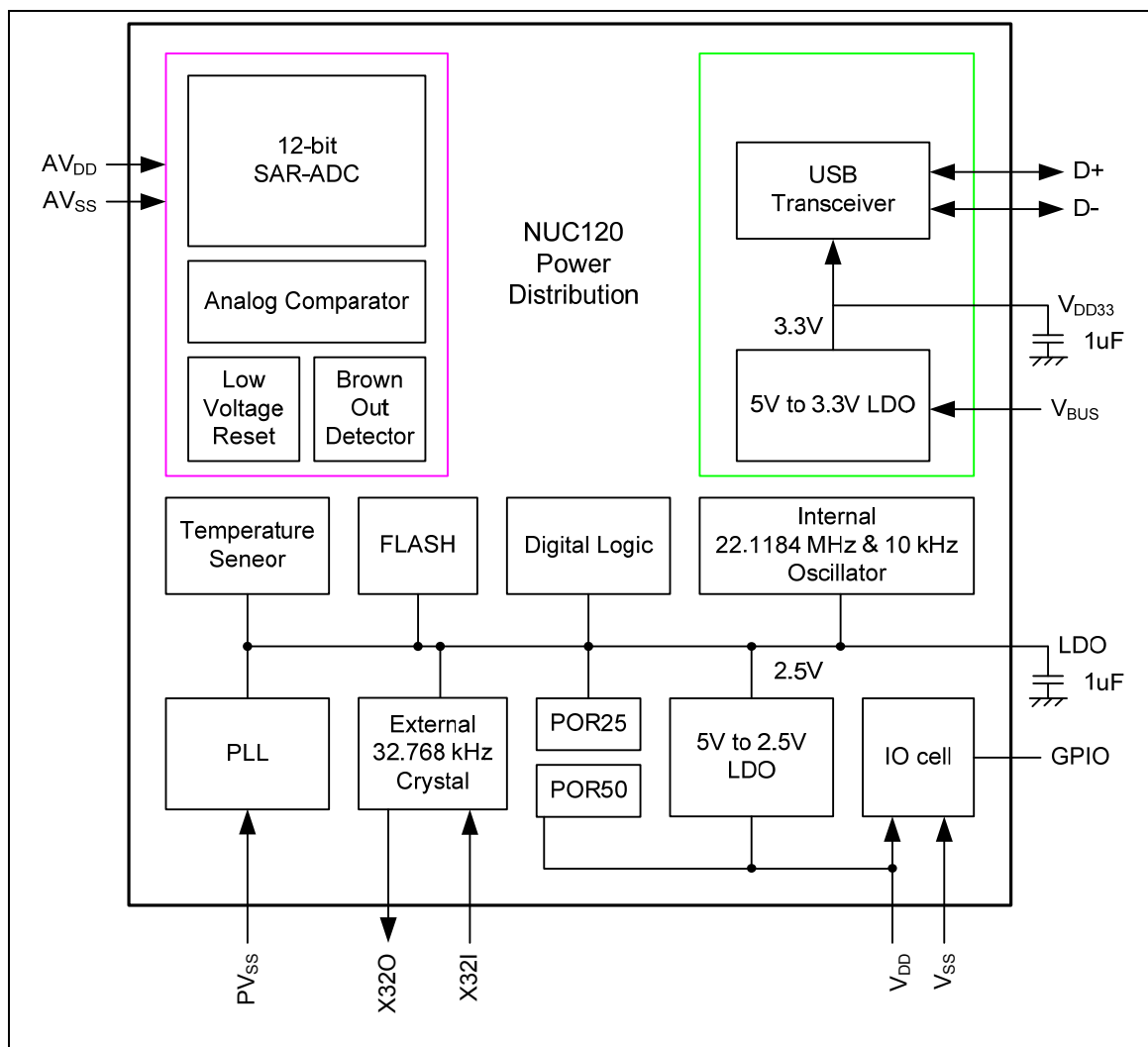

Figure 5-2 NuMicro™ NUC120 Power Distribution Diagram

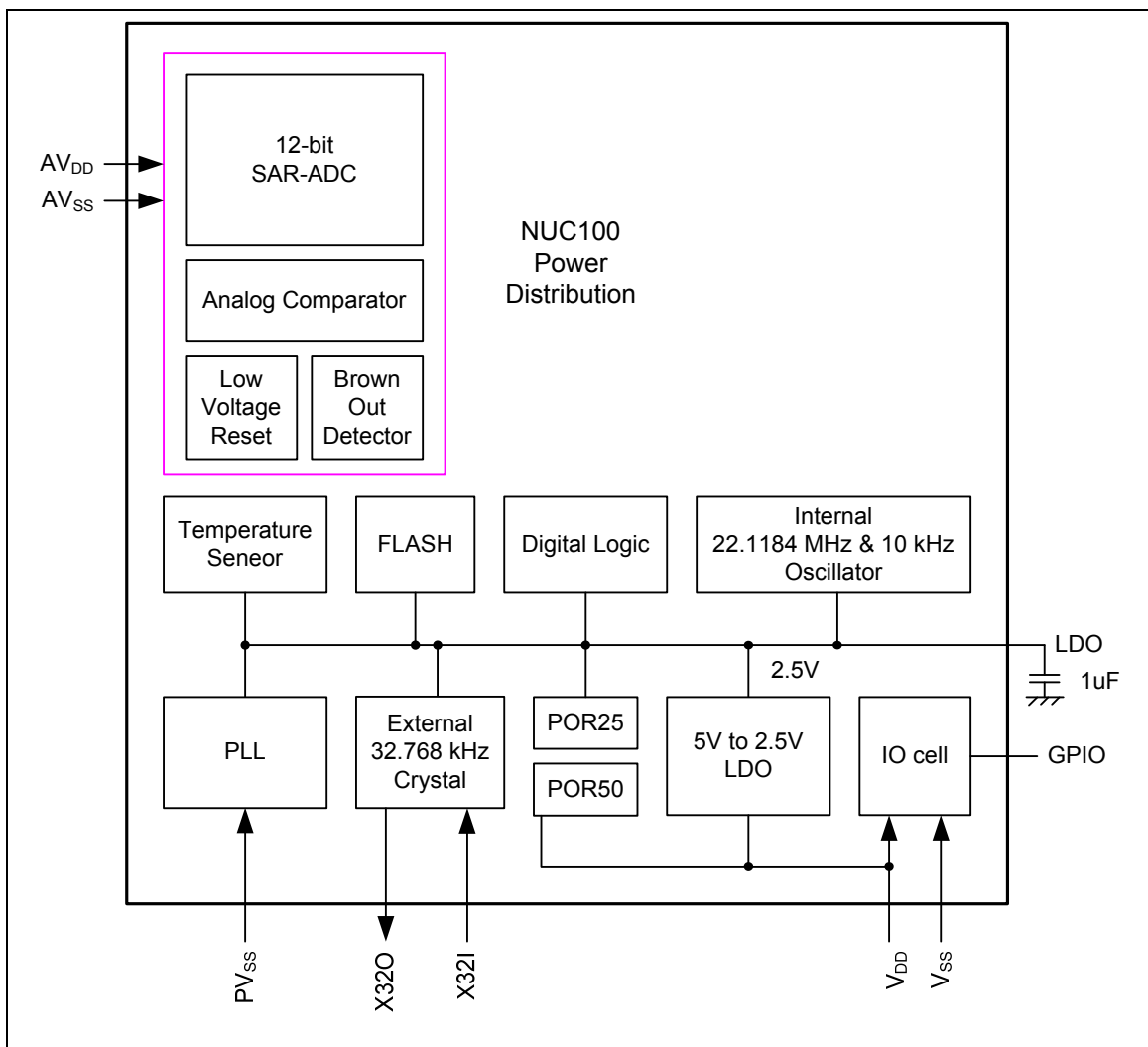

Figure 5-3 NuMicro™ NUC100 Power Distribution Diagram



## 5.2.4 System Memory Map

NuMicro™ NUC100 Series provides 4G-byte addressing space. The memory locations assigned to each on-chip controllers are shown in the following table. The detailed register definition, memory space, and programming detailed will be described in the following sections for each on-chip peripherals. NuMicro™ NUC100 Series only supports little-endian data format.

Address Space	Token	Controllers
<b>Flash and SRAM Memory Space</b>		
0x0000_0000 – 0x0001_FFFF	FLASH_BA	FLASH Memory Space (128KB)
0x2000_0000 – 0x2000_3FFF	SRAM_BA	SRAM Memory Space (16KB)
0x6000_0000 – 0x6001_FFFF	EXTMEM_BA	External Memory Space (128KB) (NuMicro™ NUC100/NUC120 Low Density 64-pin Only)
<b>AHB Controllers Space (0x5000_0000 – 0x501F_FFFF)</b>		
0x5000_0000 – 0x5000_01FF	GCR_BA	System Global Control Registers
0x5000_0200 – 0x5000_02FF	CLK_BA	Clock Control Registers
0x5000_0300 – 0x5000_03FF	INT_BA	Interrupt Multiplexer Control Registers
0x5000_4000 – 0x5000_7FFF	GPIO_BA	GPIO Control Registers
0x5000_8000 – 0x5000_BFFF	PDMA_BA	Peripheral DMA Control Registers
0x5000_C000 – 0x5000_FFFF	FMC_BA	Flash Memory Control Registers
0x5001_0000 – 0x5001_03FF	EBI_BA	External Bus Interface Control Registers (NuMicro™ NUC100/NUC120 Low Density 64-pin Only)
<b>APB1 Controllers Space (0x4000_0000 ~ 0x400F_FFFF)</b>		
0x4000_4000 – 0x4000_7FFF	WDT_BA	Watchdog Timer Control Registers
0x4000_8000 – 0x4000_BFFF	RTC_BA	Real Time Clock (RTC) Control Register
0x4001_0000 – 0x4001_3FFF	TMR01_BA	Timer0/Timer1 Control Registers
0x4002_0000 – 0x4002_3FFF	I2C0_BA	I <sup>2</sup> C0 Interface Control Registers
0x4003_0000 – 0x4003_3FFF	SPI0_BA	SPI0 with master/slave function Control Registers
0x4003_4000 – 0x4003_7FFF	SPI1_BA	SPI1 with master/slave function Control Registers
0x4004_0000 – 0x4004_3FFF	PWMA_BA	PWM0/1/2/3 Control Registers
0x4005_0000 – 0x4005_3FFF	UART0_BA	UART0 Control Registers
0x4006_0000 – 0x4006_3FFF	USBD_BA	USB 2.0 FS device Controller Registers
0x400D_0000 – 0x400D_3FFF	ACMP_BA	Analog Comparator Control Registers



Address Space	Token	Controllers
0x400E_0000 – 0x400E_FFFF	ADC_BA	Analog-Digital-Converter (ADC) Control Registers
<b>APB2 Controllers Space (0x4010_0000 ~ 0x401F_FFFF)</b>		
0x4010_0000 – 0x4010_3FFF	PS2_BA	PS/2 Interface Control Registers
0x4011_0000 – 0x4011_3FFF	TMR23_BA	Timer2/Timer3 Control Registers
0x4012_0000 – 0x4012_3FFF	I2C1_BA	I <sup>2</sup> C1 Interface Control Registers
0x4013_0000 – 0x4013_3FFF	SPI2_BA	SPI2 with master/slave function Control Registers (NuMicro™ NUC100/NUC120 Medium Density Only)
0x4013_4000 – 0x4013_7FFF	SPI3_BA	SPI3 with master/slave function Control Registers (NuMicro™ NUC100/NUC120 Medium Density Only)
0x4014_0000 – 0x4014_3FFF	PWMB_BA	PWM4/5/6/7 Control Registers (NuMicro™ NUC100/NUC120 Medium Density Only)
0x4015_0000 – 0x4015_3FFF	UART1_BA	UART1 Control Registers
0x4015_4000 – 0x4015_7FFF	UART2_BA	UART2 Control Registers (NuMicro™ NUC100/NUC120 Medium Density Only)
0x401A_0000 – 0x401A_3FFF	I2S_BA	I <sup>2</sup> S Interface Control Registers
<b>System Controllers Space (0xE000_E000 ~ 0xE000_EFFF)</b>		
0xE000_E010 – 0xE000_E0FF	SCS_BA	System Timer Control Registers
0xE000_E100 – 0xE000_ECFF	SCS_BA	External Interrupt Controller Control Registers
0xE000_ED00 – 0xE000_ED8F	SCS_BA	System Control Registers

Table 5-1 Address Space Assignments for On-Chip Controllers



### 5.2.5 System Manager Control Registers

R: read only, W: write only, R/W: both read and write

Register	Offset	R/W	Description	Reset Value
<b>GCR_BA = 0x5000_0000</b>				
<b>PDID</b>	GCR_BA+0x00	R	Part Device Identification Number Register	0x0014_0018 <sup>[1]</sup>
<b>RSTSRC</b>	GCR_BA+0x04	R/W	System Reset Source Register	0x0000_00XX
<b>IPRSTC1</b>	GCR_BA+0x08	R/W	IP Reset Control Register1	0x0000_0000
<b>IPRSTC2</b>	GCR_BA+0x0C	R/W	IP Reset Control Register2	0x0000_0000
<b>CPR</b>	GCR_BA+0x10	R/W	Chip Performance Register	0x0000_0000
<b>BODCR</b>	GCR_BA+0x18	R/W	Brown-Out Detector Control Register	0x0000_008X
<b>TEMPCR</b>	GCR_BA+0x1C	R/W	Temperature Sensor Control Register	0x0000_0000
<b>PORCR</b>	GCR_BA+0x24	R/W	Power-On-Reset Controller Register	0x0000_00XX
<b>GPA_MFP</b>	GCR_BA+0x30	R/W	GPIOA Multiple Function and Input Type Control Register	0x0000_0000
<b>GPB_MFP</b>	GCR_BA+0x34	R/W	GPIOB Multiple Function and Input Type Control Register	0x0000_0000
<b>GPC_MFP</b>	GCR_BA+0x38	R/W	GPIOC Multiple Function and Input Type Control Register	0x0000_0000
<b>GPD_MFP</b>	GCR_BA+0x3C	R/W	GPIOD Multiple Function and Input Type Control Register	0x0000_0000
<b>GPE_MFP</b>	GCR_BA+0x40	R/W	GPIOE Multiple Function and Input Type Control Register	0x0000_0000
<b>ALT_MFP</b>	GCR_BA+0x50	R/W	Alternative Multiple Function Pin Control Register	0x0000_0000
<b>REGWRPROT</b>	GCR_BA+0x100	R/W	Register Write Protect register	0x0000_0000

Note: [1] Depends on part number.



## Part Device ID Code Register (PDID)

Register	Offset	R/W	Description	Reset Value
PDID	GCR_BA+0x00	R	Part Device Identification Number Register	0x0014_0018 <sup>[1]</sup>

[1] Each part number has a unique default reset value.

31	30	29	28	27	26	25	24
PDID[31:24]							
23	22	21	20	19	18	17	16
PDID[23:16]							
15	14	13	12	11	10	9	8
PDID[15:8]							
7	6	5	4	3	2	1	0
PDID[7:0]							

Bits	Descriptions	
[31:0]	<b>PDID</b>	<p><b>Part Device Identification Number</b></p> <p>This register reflects device part number code. S/W can read this register to identify which device is used.</p>



## System Reset Source Register (RSTSRC)

This register provides specific information for software to identify this chip's reset source from last operation.

Register	Offset	R/W	Description	Reset Value
RSTSRC	GCR_BA+0x04	R/W	System Reset Source Register	0x0000_00XX

31	30	29	28	27	26	25	24
Reserved							
23	22	21	20	19	18	17	16
Reserved							
15	14	13	12	11	10	9	8
Reserved							
7	6	5	4	3	2	1	0
RSTS_CPU	Reserved	RSTS_SYS	RSTS_BOD	RSTS_LVR	RSTS_WDT	RSTS_RESE T	RSTS_POR

Bits	Descriptions	
[31:8]	Reserved	Reserved
[7]	RSTS_CPU	The RSTS_CPU flag is set by hardware if software writes CPU_RST (IPRSTC1[1]) 1 to reset Cortex-M0 CPU kernel and Flash memory controller (FMC).  1 = The Cortex-M0 CPU kernel and FMC are reset by software setting CPU_RST to 1. 0 = No reset from CPU  Software can write 1 to clear this bit to zero.
[6]	Reserved	Reserved
[5]	RSTS_SYS	The RSTS_SYS flag is set by the "reset signal" from the Cortex_M0 kernel to indicate the previous reset source.  1 = The Cortex_M0 had issued the reset signal to reset the system by software writing 1 to bit SYSRESETREQ(AIRCR[2], Application Interrupt and Reset Control Register, address = 0xE000ED0C) in system control registers of Cortex_M0 kernel.  0 = No reset from Cortex_M0  Software can write 1 to clear this bit to zero.
[4]	RSTS_BOD	The RSTS_BOD flag is set by the "reset signal" from the Brown-Out-Detector to indicate the previous reset source.  1 = The BOD had issued the reset signal to reset the system 0 = No reset from BOD  Software can write 1 to clear this bit to zero.
[3]	RSTS_LVR	The RSTS_LVR flag is set by the "reset signal" from the Low-Voltage-Reset controller to indicate the previous reset source.



Bits	Descriptions	
		1 = The LVR controller had issued the reset signal to reset the system. 0 = No reset from LVR Software can write 1 to clear this bit to zero.
[2]	<b>RSTS_WDT</b>	The RSTS_WDT flag is set by the “reset signal” from the watchdog timer to indicate the previous reset source. 1 = The watchdog timer had issued the reset signal to reset the system. 0 = No reset from watchdog timer Software can write 1 to clear this bit to zero.
[1]	<b>RSTS_RESET</b>	The RSTS_RESET flag is set by the “reset signal” from the /RESET pin to indicate the previous reset source. 1 = The Pin /RESET had issued the reset signal to reset the system. 0 = No reset from /RESET pin Software can write 1 to clear this bit to zero.
[0]	<b>RSTS_POR</b>	The RSTS_POR flag is set by the “reset signal” from the Power-On Reset (POR) controller or bit CHIP_RST (IPRSTC1[0]) to indicate the previous reset source. 1 = The Power-On Reset (POR) or CHIP_RST had issued the reset signal to reset the system. 0 = No reset from POR or CHIP_RST Software can write 1 to clear this bit to zero.





## Peripheral Reset Control Register1 (IPRSTC1)

Register	Offset	R/W	Description	Reset Value
IPRSTC1	GCR_BA+0x08	R/W	IP Reset Control Register 1	0x0000_0000

31	30	29	28	27	26	25	24
Reserved							
23	22	21	20	19	18	17	16
Reserved							
15	14	13	12	11	10	9	8
Reserved							
7	6	5	4	3	2	1	0
Reserved				EBI_RST	PDMA_RST	CPU_RST	CHIP_RST

Bits	Descriptions	
[31:4]	Reserved	Reserved
[3]	<b>EBI_RST</b>	<p><b>EBI Controller Reset</b> (NuMicro™ NUC100/NUC120 Low Density 64 pin package Only) (write-protection bit in NuMicro™ NUC100/NUC120 Low Density 64-pin package)</p> <p>Set this bit to 1 will generate a reset signal to the EBI. User need to set this bit to 0 to release from the reset state.</p> <p>This bit is the protected bit, It means programming this bit needs to write “59h”, “16h”, “88h” to address 0x5000_0100 to disable register protection. Reference the register REGWRPROT at address GCR_BA+0x100</p> <p>1 = EBI controller reset 0 = EBI controller normal operation</p>
[2]	<b>PDMA_RST</b>	<p><b>PDMA Controller Reset</b> (write-protection bit in NuMicro™ NUC100/NUC120 Low Density)</p> <p>Setting this bit to 1 will generate a reset signal to the PDMA. User need to set this bit to 0 to release from reset state.</p> <p>This bit is the protected bit, It means programming this bit needs to write “59h”, “16h”, “88h” to address 0x5000_0100 to disable register protection. Reference the register REGWRPROT at address GCR_BA+0x100.</p> <p>1 = PDMA controller reset 0 = PDMA controller normal operation</p>
[1]	<b>CPU_RST</b>	<p><b>CPU kernel one shot reset</b> (write-protection bit)</p> <p>Setting this bit will only reset the CPU kernel and Flash Memory Controller(FMC), and this bit will automatically return to 0 after the 2 clock cycles</p> <p>This bit is the protected bit, It means programming this bit needs to write “59h”, “16h”, “88h” to address 0x5000_0100 to disable register protection. Reference the register REGWRPROT at address GCR_BA+0x100</p> <p>1 = CPU one shot reset</p>



Bits	Descriptions	
		0 = CPU normal operation
[0]	<b>CHIP_RST</b>	<p><b>CHIP one shot reset</b> (write-protection bit)</p> <p>Setting this bit will reset the whole chip, including CPU kernel and all peripherals, and this bit will automatically return to 0 after the 2 clock cycles.</p> <p>The CHIP_RST is same as the POR reset, all the chip controllers is reset and the chip setting from flash are also reload.</p> <p>About the difference between CHIP_RST and SYSRESETREQ, please refer to section 5.2.2</p> <p>This bit is the protected bit. It means programming this bit needs to write "59h", "16h", "88h" to address 0x5000_0100 to disable register protection. Reference the register REGWRPROT at address GCR_BA+0x100</p> <p>1 = CHIP one shot reset 0 = CHIP normal operation</p>



## Peripheral Reset Control Register2 (IPRSTC2)

Setting these bits 1 will generate asynchronous reset signals to the corresponding IP controller. Users need to set these bits to 0 to release corresponding IP controller from reset state

Register	Offset	R/W	Description	Reset Value
IPRSTC2	GCR_BA+0x0C	R/W	Peripheral Controller Reset Control Register 2	0x0000_0000

31	30	29	28	27	26	25	24
Reserved		I2S_RST	ADC_RST	USBD_RST	Reserved		
23	22	21	20	19	18	17	16
PS2_RST	ACMP_RST	PWM47_RST	PWM03_RST	Reserved	UART2_RST	UART1_RST	UART0_RST
15	14	13	12	11	10	9	8
SPI3_RST	SPI2_RST	SPI1_RST	SPI0_RST	Reserved		I2C1_RST	I2C0_RST
7	6	5	4	3	2	1	0
Reserved		TMR3_RST	TMR2_RST	TMR1_RST	TMR0_RST	GPIO_RST	Reserved

Bits	Descriptions	
[31:30]	Reserved	Reserved
[29]	I2S_RST	<b>I<sup>2</sup>S Controller Reset</b> 1 = I <sup>2</sup> S controller reset 0 = I <sup>2</sup> S controller normal operation
[28]	ADC_RST	<b>ADC Controller Reset</b> 1 = ADC controller reset 0 = ADC controller normal operation
[27]	USBD_RST	<b>USB Device Controller Reset</b> 1 = USB device controller reset 0 = USB device controller normal operation
[26:24]	Reserved	Reserved
[23]	PS2_RST	<b>PS/2 Controller Reset</b> 1 = PS/2 controller reset 0 = PS/2 controller normal operation
[22]	ACMP_RST	<b>Analog Comparator Controller Reset</b> 1 = Analog Comparator controller reset 0 = Analog Comparator controller normal operation
[21]	PWM47_RST	<b>PWM47 controller Reset (NuMicro™ NUC100/NUC120 Medium Density Only)</b> 1 = PWM47 controller reset



Bits	Descriptions	
		0 = PWM47 controller normal operation
[20]	<b>PWM03_RST</b>	<b>PWM03 controller Reset</b> 1 = PWM03 controller reset 0 = PWM03 controller normal operation
[19]	<b>Reserved</b>	Reserved
[18]	<b>UART2_RST</b>	<b>UART2 controller Reset</b> (NuMicro™ NUC100/NUC120 Medium Density Only) 1 = UART2 controller reset 0 = UART2 controller normal operation
[17]	<b>UART1_RST</b>	<b>UART1 controller Reset</b> 1 = UART1 controller reset 0 = UART1 controller normal operation
[16]	<b>UART0_RST</b>	<b>UART0 controller Reset</b> 1 = UART0 controller reset 0 = UART0 controller normal operation
[15]	<b>SPI3_RST</b>	<b>SPI3 controller Reset</b> (NuMicro™ NUC100/NUC120 Medium Density Only) 1 = SPI3 controller reset 0 = SPI3 controller normal operation
[14]	<b>SPI2_RST</b>	<b>SPI2 controller Reset</b> (NuMicro™ NUC100/NUC120 Medium Density Only) 1 = SPI2 controller reset 0 = SPI2 controller normal operation
[13]	<b>SPI1_RST</b>	<b>SPI1 controller Reset</b> 1 = SPI1 controller reset 0 = SPI1 controller normal operation
[12]	<b>SPI0_RST</b>	<b>SPI0 controller Reset</b> 1 = SPI0 controller reset 0 = SPI0 controller normal operation
[11:10]	<b>Reserved</b>	Reserved
[9]	<b>I2C1_RST</b>	<b>I<sup>2</sup>C1 controller Reset</b> 1 = I <sup>2</sup> C1 controller reset 0 = I <sup>2</sup> C1 controller normal operation
[8]	<b>I2C0_RST</b>	<b>I<sup>2</sup>C0 controller Reset</b> 1 = I <sup>2</sup> C0 controller reset 0 = I <sup>2</sup> C0 controller normal operation
[7:6]	<b>Reserved</b>	Reserved
[5]	<b>TMR3_RST</b>	<b>Timer3 controller Reset</b> 1 = Timer3 controller reset



Bits	Descriptions	
		0 = Timer3 controller normal operation
[4]	<b>TMR2_RST</b>	<b>Timer2 controller Reset</b> 1 = Timer2 controller reset 0 = Timer2 controller normal operation
[3]	<b>TMR1_RST</b>	<b>Timer1 controller Reset</b> 1 = Timer1 controller reset 0 = Timer1 controller normal operation
[2]	<b>TMR0_RST</b>	<b>Timer0 controller Reset</b> 1 = Timer0 controller reset 0 = Timer0 controller normal operation
[1]	<b>GPIO_RST</b>	<b>GPIO controller Reset</b> 1 = GPIO controller reset 0 = GPIO controller normal operation
[0]	<b>Reserved</b>	Reserved



## Chip Performance Register (CPR)

This register is used to control CHIP performance (Low Density Only)

Register	Offset	R/W	Description	Reset Value
CPR	GCR_BA+0x10	R/W	Chip Performance Register	0x0000_0000

31	30	29	28	27	26	25	24
Reserved							
23	22	21	20	19	18	17	16
Reserved							
15	14	13	12	11	10	9	8
Reserved							
7	6	5	4	3	2	1	0
Reserved							HPE

Bits	Descriptions	
[31:1]	Reserved	Reserved
[0]	HPE	<p><b>High Performance Enable</b> (write-protection bit)</p> <p>This bit is used to control chip operation performance.</p> <p>When this bit set, internal RAM and GPIO access is working with zero wait state, and Flash controller will predict next address more efficiently. The high performance is enabled without limiting by chip operation frequency.</p> <p>1 = Chip operation at high performance mode 0 = Chip operation at normal mode</p>



## Brown-Out Detector Control Register (BODCR)

Partial of the BODCR control registers values are initiated by the flash configuration and partial bits are write-protected bit. Programming write-protected bits needs to write “59h”, “16h”, “88h” to address 0x5000\_0100 to disable register protection. Reference the register REGWRPROT at address GCR\_BA+0x100

Register	Offset	R/W	Description	Reset Value
BODCR	GCR_BA+0x18	R/W	Brown-Out Detector Control Register	0x0000_008X

31	30	29	28	27	26	25	24
Reserved							
23	22	21	20	19	18	17	16
Reserved							
15	14	13	12	11	10	9	8
Reserved							
7	6	5	4	3	2	1	0
LVR_EN	BOD_OUT	BOD_LPM	BOD_INTF	BOD_RSTEN	BOD_VL		BOD_EN

Bits	Descriptions
[31:8]	<b>Reserved</b> Reserved
[7]	<p><b>LVR_EN</b></p> <p><b>Low Voltage Reset Enable</b> (write-protection bit)</p> <p>The LVR function reset the chip when the input power voltage is lower than LVR circuit setting. LVR function is enabled in default.</p> <p>1 = Enabled Low Voltage Reset function – After enabling the bit, the LVR function will be active with 100uS delay for LVR output stable. (Default).</p> <p>0 = Disabled Low Voltage Reset function</p> <p>This bit is the protected bit. It means programming this needs to write “59h”, “16h”, “88h” to address 0x5000_0100 to disable register protection. Reference the register REGWRPROT at address GCR_BA+0x100</p>
[6]	<p><b>BOD_OUT</b></p> <p><b>Brown-Out Detector output status</b></p> <p>1 = Brown-Out Detector output status is 1. It means the detected voltage is lower than BOD_VL setting. If the BOD_EN is 0, BOD function disabled, this bit always responds 0</p> <p>0 = Brown-Out Detector output status is 0. It means the detected voltage is higher than BOD_VL setting or BOD_EN is 0</p>
[5]	<p><b>BOD_LPM</b></p> <p><b>Brown-Out Detector Low power Mode</b> (write-protection bit)</p> <p>1 = Enable the BOD low power mode</p> <p>0 = BOD operate in normal mode (default)</p> <p>The BOD consumes about 100 uA in normal mode, the low power mode can reduce the current to about 1/10 but slow the BOD response.</p>



Bits	Descriptions																
		This bit is the protected bit. It means programming this needs to write "59h", "16h", "88h" to address 0x5000_0100 to disable register protection. Reference the register REGWRPROT at address GCR_BA+0x100.															
[4]	<b>BOD_INTF</b>	<p><b>Brown-Out Detector Interrupt Flag</b></p> <p>1 = When Brown-Out Detector detects the V<sub>DD</sub> is dropped down through the voltage of BOD_VL setting or the V<sub>DD</sub> is raised up through the voltage of BOD_VL setting, this bit is set to 1 and the Brown-Out interrupt is requested if Brown-Out interrupt is enabled.</p> <p>0 = Brown-Out Detector does not detect any voltage draft at V<sub>DD</sub> down through or up through the voltage of BOD_VL setting.</p> <p>Software can write 1 to clear this bit to zero.</p>															
[3]	<b>BOD_RSTEN</b>	<p><b>Brown-Out Reset Enable</b> (write-protection bit)</p> <p>1 = Enable the Brown-Out "RESET" function</p> <p>While the Brown-Out Detector function is enabled (BOD_EN high) and BOD reset function is enabled (BOD_RSTEN high), BOD will assert a signal to reset chip when the detected voltage is lower than the threshold (BOD_OUT high).</p> <p>0 = Enable the Brown-Out "INTERRUPT" function</p> <p>While the BOD function is enabled (BOD_EN high) and BOD interrupt function is enabled (BOD_RSTEN low), BOD will assert an interrupt if BOD_OUT is high. BOD interrupt will keep till to the BOD_EN set to 0. BOD interrupt can be blocked by disabling the NVIC BOD interrupt or disabling BOD function (set BOD_EN low).</p> <p>The default value is set by flash controller user configuration register config0 bit[20].</p> <p>This bit is the protected bit. It means programming this needs to write "59h", "16h", "88h" to address 0x5000_0100 to disable register protection. Reference the register REGWRPROT at address GCR_BA+0x100.</p>															
[2:1]	<b>BOD_VL</b>	<p><b>Brown-Out Detector Threshold Voltage Selection</b> (write-protection bits)</p> <p>The default value is set by flash controller user configuration register config0 bit[22:21]</p> <p>This bit is the protected bit. It means programming this needs to write "59h", "16h", "88h" to address 0x5000_0100 to disable register protection. Reference the register REGWRPROT at address GCR_BA+0x100.</p> <table border="1" style="width: 100%; border-collapse: collapse;"> <thead> <tr> <th style="text-align: center;">BOV_VL[1]</th> <th style="text-align: center;">BOV_VL[0]</th> <th style="text-align: center;">Brown-Out voltage</th> </tr> </thead> <tbody> <tr> <td style="text-align: center;">1</td> <td style="text-align: center;">1</td> <td style="text-align: center;">4.5 V</td> </tr> <tr> <td style="text-align: center;">1</td> <td style="text-align: center;">0</td> <td style="text-align: center;">3.8 V</td> </tr> <tr> <td style="text-align: center;">0</td> <td style="text-align: center;">1</td> <td style="text-align: center;">2.7 V</td> </tr> <tr> <td style="text-align: center;">0</td> <td style="text-align: center;">0</td> <td style="text-align: center;">2.2 V</td> </tr> </tbody> </table>	BOV_VL[1]	BOV_VL[0]	Brown-Out voltage	1	1	4.5 V	1	0	3.8 V	0	1	2.7 V	0	0	2.2 V
BOV_VL[1]	BOV_VL[0]	Brown-Out voltage															
1	1	4.5 V															
1	0	3.8 V															
0	1	2.7 V															
0	0	2.2 V															
[0]	<b>BOD_EN</b>	<p><b>Brown-Out Detector Enable</b> (write-protection bit)</p> <p>The default value is set by flash controller user configuration register config0 bit[23]</p> <p>1 = Brown-Out Detector function is enabled</p> <p>0 = Brown-Out Detector function is disabled</p> <p>This bit is the protected bit. It means programming this needs to write "59h", "16h", "88h" to address 0x5000_0100 to disable register protection. Reference the register REGWRPROT at address GCR_BA+0x100.</p>															





## Temperature Sensor Control Register (TEMPCR)

Register	Offset	R/W	Description	Reset Value
TEMPCR	GCR_BA+0x1C	R/W	Temperature Sensor Control Register	0x0000_0000

31	30	29	28	27	26	25	24
Reserved							
23	22	21	20	19	18	17	16
Reserved							
15	14	13	12	11	10	9	8
Reserved							
7	6	5	4	3	2	1	0
Reserved							VTEMP_EN

Bits	Descriptions	
[31:1]	Reserved	Reserved
[0]	VTEMP_EN	<p><b>Temperature sensor Enable</b></p> <p>This bit is used to enable/disable temperature sensor function.</p> <p>1 = Enabled temperature sensor function</p> <p>0 = Disabled temperature sensor function (default)</p> <p>After this bit is set to 1, the value of temperature can get from ADC conversion result by ADC channel selecting channel 7 and alternative multiplexer channel selecting temperature sensor. Detail ADC conversion function please reference ADC function chapter.</p>



**Power-On-Reset Control Register (PORCR)**

Register	Offset	R/W	Description	Reset Value
PORCR	GCR_BA+0x24	R/W	Power-On-Reset Controller Register	0x0000_00XX

31	30	29	28	27	26	25	24
Reserved							
23	22	21	20	19	18	17	16
Reserved							
15	14	13	12	11	10	9	8
POR_DIS_CODE[15:8]							
7	6	5	4	3	2	1	0
POR_DIS_CODE[7:0]							

Bits	Descriptions	
[31:16]	Reserved	Reserved
[15:0]	POR_DIS_CODE	<p><b>The register is used for the Power-On-Reset enable control</b> (write-protection bits)</p> <p>When power on, the POR circuit generates a reset signal to reset the whole chip function, but noise on the power may cause the POR active again. User can disable internal POR circuit to avoid unpredictable noise to cause chip reset by writing 0x5AA5 to this field.</p> <p>The POR function will be active again when this field is set to another value or chip is reset by other reset source, including:</p> <p>/RESET, Watchdog, LVR reset, BOD reset, ICE reset command and the software-chip reset function</p> <p>This bit is the protected bit. It means programming this needs to write "59h", "16h", "88h" to address 0x5000_0100 to disable register protection. Reference the register REGWRPROT at address GCR_BA+0x100.</p>



## Multiple Function Pin GPIOA Control Register (GPA\_MFP)

Register	Offset	R/W	Description	Reset Value
GPA_MFP	GCR_BA+0x30	R/W	GPIOA Multiple Function and Input Type Control Register	0x0000_0000

31	30	29	28	27	26	25	24
GPA_TYPE[15:8]							
23	22	21	20	19	18	17	16
GPA_TYPE[7:0]							
15	14	13	12	11	10	9	8
GPA_MFP[15:8]							
7	6	5	4	3	2	1	0
GPA_MFP[7:0]							

Bits	Descriptions																			
[31:16]	<b>GPA_TYPEn</b>	1 = Enable GPIOA[15:0] I/O input Schmitt Trigger function 0 = Disable GPIOA[15:0] I/O input Schmitt Trigger function																		
[15]	<b>GPA_MFP15</b>	<b>PA.15 Pin Function Selection</b> The pin function depends on GPA_MFP15 and PA15_I2SMCLK (ALT_MFP[9]). <table border="1" style="width: 100%; margin-top: 5px;"> <thead> <tr> <th>PA15_I2SMCLK</th> <th>GPA_MFP[15]</th> <th>PA.15 function</th> </tr> </thead> <tbody> <tr> <td>0</td> <td>0</td> <td>GPIO</td> </tr> <tr> <td>0</td> <td>1</td> <td>PWM3 (PWM)</td> </tr> <tr> <td>1</td> <td>1</td> <td>I2SMCLK (I<sup>2</sup>S)</td> </tr> </tbody> </table>			PA15_I2SMCLK	GPA_MFP[15]	PA.15 function	0	0	GPIO	0	1	PWM3 (PWM)	1	1	I2SMCLK (I <sup>2</sup> S)				
PA15_I2SMCLK	GPA_MFP[15]	PA.15 function																		
0	0	GPIO																		
0	1	PWM3 (PWM)																		
1	1	I2SMCLK (I <sup>2</sup> S)																		
[14]	<b>GPA_MFP14</b>	<b>PA.14 Pin Function Selection</b> The pin function depends on GPA_MFP14 and EBI_HB_EN[7] (ALT_MFP[23]) and EBI_EN (ALT_MFP[11]). <table border="1" style="width: 100%; margin-top: 5px;"> <thead> <tr> <th>EBI_HB_EN[7]</th> <th>EBI_EN</th> <th>GPA_MFP[14]</th> <th>PA.14 function</th> </tr> </thead> <tbody> <tr> <td>0</td> <td>0</td> <td>0</td> <td>GPIO</td> </tr> <tr> <td>0</td> <td>0</td> <td>1</td> <td>PWM2 (PWM)</td> </tr> <tr> <td>1</td> <td>1</td> <td>1</td> <td>AD15 (EBI AD bus bit 15)</td> </tr> </tbody> </table>			EBI_HB_EN[7]	EBI_EN	GPA_MFP[14]	PA.14 function	0	0	0	GPIO	0	0	1	PWM2 (PWM)	1	1	1	AD15 (EBI AD bus bit 15)
EBI_HB_EN[7]	EBI_EN	GPA_MFP[14]	PA.14 function																	
0	0	0	GPIO																	
0	0	1	PWM2 (PWM)																	
1	1	1	AD15 (EBI AD bus bit 15)																	
[13]	<b>GPA_MFP13</b>	<b>PA.13 Pin Function Selection</b> The pin function depends on GPA_MFP13 and EBI_HB_EN[6] (ALT_MFP[22]) and EBI_EN (ALT_MFP[11]). <table border="1" style="width: 100%; margin-top: 5px;"> <thead> <tr> <th>EBI_HB_EN[6]</th> <th>EBI_EN</th> <th>GPA_MFP[13]</th> <th>PA.13 function</th> </tr> </thead> <tbody> <tr> <td>0</td> <td>0</td> <td>0</td> <td>GPIO</td> </tr> <tr> <td>0</td> <td>0</td> <td>1</td> <td>PWM1 (PWM)</td> </tr> </tbody> </table>			EBI_HB_EN[6]	EBI_EN	GPA_MFP[13]	PA.13 function	0	0	0	GPIO	0	0	1	PWM1 (PWM)				
EBI_HB_EN[6]	EBI_EN	GPA_MFP[13]	PA.13 function																	
0	0	0	GPIO																	
0	0	1	PWM1 (PWM)																	



Bits	Descriptions				
		1	1	1	AD14 (EBI AD bus bit 14)
[12]	<b>GPA_MFP12</b>	<b>PA.12 Pin Function Selection</b> The pin function depends on GPA_MFP12 and EBI_HB_EN[5] (ALT_MFP[21]) and EBI_EN (ALT_MFP[11]).			
		EBI_HB_EN[5]	EBI_EN	GPA_MFP[12]	PA.12 function
		0	0	0	GPIO
		0	0	1	PWM0 (PWM)
		1	1	1	AD13 (EBI AD bus bit 13)
[11]	<b>GPA_MFP11</b>	<b>PA.11 Pin Function Selection</b> The pin function depends on GPA_MFP11 and EBI_EN (ALT_MFP[11]).			
		EBI_EN	GPA_MFP[11]	PA.11 function	
		0	0	GPIO	
		0	1	SCL1 (I <sup>2</sup> C)	
		1	1	nRD (EBI)	
[10]	<b>GPA_MFP10</b>	<b>PA.10 Pin Function Selection</b> The pin function depends on GPA_MFP10 and EBI_EN (ALT_MFP[11]).			
		EBI_EN	GPA_MFP[10]	PA.10 function	
		0	0	GPIO	
		0	1	SDA1 (I <sup>2</sup> C)	
		1	1	nWR (EBI)	
[9]	<b>GPA_MFP9</b>	<b>PA.9 Pin Function Selection</b> 1 = The I <sup>2</sup> C0 SCL function is selected to the pin PA.9 0 = The GPIOA[9] is selected to the pin PA.9			
[8]	<b>GPA_MFP8</b>	<b>PA.8 Pin Function Selection</b> 1 = The I <sup>2</sup> C0 SDA function is selected to the pin PA.8 0 = The GPIOA[8] is selected to the pin PA.8			
[7]	<b>GPA_MFP7</b>	<b>PA.7 Pin Function Selection</b> The pin function depends on GPA_MFP7 and PA7_S21 (ALT_MFP[2]) and EBI_EN (ALT_MFP[11]).			
		EBI_EN	PA7_S21	GPA_MFP[7]	PA.7 function
		0	0	0	GPIO
		0	0	1	ADC7 (ADC)
		0	1	1	SPISS21 (SPI2)
		1	0	1	AD6 (EBI AD bus bit 6)
[6]	<b>GPA_MFP6</b>	<b>PA.6 Pin Function Selection</b>			



Bits	Descriptions				
		The pin function depends on GPA_MFP6 and EBI_EN (ALT_MFP[11]).			
		EBI_EN	GPA_MFP[6]	PA.6 function	
		0	0	GPIO	
		0	1	ADC6 (ADC)	
		1	1	AD7 (EBI AD bus bit 7)	
[5]	GPA_MFP5	<b>PA.5 Pin Function Selection</b> The pin function depends on GPA_MFP5 and EBI_HB_EN[0] (ALT_MFP[16]) and EBI_EN (ALT_MFP[11]).			
		EBI_HB_EN[0]	EBI_EN	GPA_MFP[5]	PA.5 function
		0	0	0	GPIO
		0	0	1	ADC5 (ADC)
		1	1	1	AD8 (EBI AD bus bit 8)
[4]	GPA_MFP4	<b>PA.4 Pin Function Selection</b> The pin function depends on GPA_MFP4 and EBI_HB_EN[1] (ALT_MFP[17]) and EBI_EN (ALT_MFP[11]).			
		EBI_HB_EN[1]	EBI_EN	GPA_MFP[4]	PA.4 function
		0	0	0	GPIO
		0	0	1	ADC4 (ADC)
		1	1	1	AD9 (EBI AD bus bit 9)
[3]	GPA_MFP3	<b>PA.3 Pin Function Selection</b> The pin function depends on GPA_MFP3 and EBI_HB_EN[2] (ALT_MFP[18]) and EBI_EN (ALT_MFP[11]).			
		EBI_HB_EN[2]	EBI_EN	GPA_MFP[3]	PA.3 function
		0	0	0	GPIO
		0	0	1	ADC3 (ADC)
		1	1	1	AD10 (EBI AD bus bit 10)
[2]	GPA_MFP2	<b>PA.2 Pin Function Selection</b> The pin function depends on GPA_MFP2 and EBI_HB_EN[3] (ALT_MFP[19]) and EBI_EN (ALT_MFP[11]).			
		EBI_HB_EN[3]	EBI_EN	GPA_MFP[2]	PA.2 function
		0	0	0	GPIO
		0	0	1	ADC2 (ADC)
		1	1	1	AD11 (EBI AD bus bit 11)
[1]	GPA_MFP1	<b>PA.1 Pin Function Selection</b> The pin function depends on GPA_MFP1 and EBI_HB_EN[4] (ALT_MFP[20]) and EBI_EN (ALT_MFP[11]).			



Bits	Descriptions				
		EBI_HB_EN[4]	EBI_EN	GPA_MFP[1]	PA.1 function
		0	0	0	GPIO
		0	0	1	ADC1 (ADC)
		1	1	1	AD12 (EBI AD bus bit 12)
[0]	<b>GPA_MFP0</b>	<b>PA.0 Pin Function Selection</b> 1 = The ADC0 (Analog-to-Digital converter channel 0) function is selected to the pin PA.0 0 = The GPIOA[0] is selected to the pin PA.0			



## Multiple Function Pin GPIOB Control Register (GPB\_MFP)

Register	Offset	R/W	Description	Reset Value
GPB_MFP	GCR_BA+0x34	R/W	GPIOB Multiple Function and Input Type Control Register	0x0000_0000

31	30	29	28	27	26	25	24
GPB_TYPE[15:8]							
23	22	21	20	19	18	17	16
GPB_TYPE[7:0]							
15	14	13	12	11	10	9	8
GPB_MFP[15:8]							
7	6	5	4	3	2	1	0
GPB_MFP[7:0]							

Bits	Descriptions													
[31:16]	<b>GPB_TYPE<sub>n</sub></b>	1 = Enable GPIOB[15:0] I/O input Schmitt Trigger function 0 = Disable GPIOB[15:0] I/O input Schmitt Trigger function												
[15]	<b>GPB_MFP15</b>	<b>PB.15 Pin Function Selection</b> 1 = The External Interrupt INT1 function is selected to the pin PB.15 0 = The GPIOB[15] is selected to the pin PB.15												
[14]	<b>GPB_MFP14</b>	<b>PB.14 Pin Function Selection</b> The pin function depends on GPB_MFP14 and PB14_S31 (ALT_MFP[3]) <table border="1" style="margin-left: 20px;"> <thead> <tr> <th>PB14_S31</th> <th>GPB_MFP[14]</th> <th>PB.14 function</th> </tr> </thead> <tbody> <tr> <td>0</td> <td>0</td> <td>GPIO</td> </tr> <tr> <td>0</td> <td>1</td> <td>/INT0</td> </tr> <tr> <td>1</td> <td>1</td> <td>SPISS31 (SPI3)</td> </tr> </tbody> </table>	PB14_S31	GPB_MFP[14]	PB.14 function	0	0	GPIO	0	1	/INT0	1	1	SPISS31 (SPI3)
PB14_S31	GPB_MFP[14]	PB.14 function												
0	0	GPIO												
0	1	/INT0												
1	1	SPISS31 (SPI3)												
[13]	<b>GPB_MFP13</b>	<b>PB.13 Pin Function Selection</b> The pin function depends on GPB_MFP13 and EBI_EN (ALT_MFP[11]). <table border="1" style="margin-left: 20px;"> <thead> <tr> <th>EBI_EN</th> <th>GPB_MFP[13]</th> <th>PB.13 function</th> </tr> </thead> <tbody> <tr> <td>0</td> <td>0</td> <td>GPIO</td> </tr> <tr> <td>0</td> <td>1</td> <td>CPO1 (CMP)</td> </tr> <tr> <td>1</td> <td>1</td> <td>AD1 (EBI AD bus bit 1)</td> </tr> </tbody> </table>	EBI_EN	GPB_MFP[13]	PB.13 function	0	0	GPIO	0	1	CPO1 (CMP)	1	1	AD1 (EBI AD bus bit 1)
EBI_EN	GPB_MFP[13]	PB.13 function												
0	0	GPIO												
0	1	CPO1 (CMP)												
1	1	AD1 (EBI AD bus bit 1)												
[12]	<b>GPB_MFP12</b>	<b>PB.12 Pin Function Selection</b> The pin function depends on GPB_MFP12 and PB12_CLKO (ALT_MFP[10]) and EBI_EN (ALT_MFP[11]).												



Bits	Descriptions				
		EBI_EN	PB12_CLKO	GPB_MFP[12]	PB.12 function
		0	0	0	GPIO
		0	0	1	CPO0 (CMP)
		0	1	1	CLKO (Clock Driver output)
		1	0	1	AD0 (EBI AD bus bit 0)
[11]	GPB_MFP11	<b>PB.11 Pin Function Selection</b> The pin function depends on GPB_MFP11 and PB11_PWM4 (ALT_MFP[4]).			
		PB11_PWM4	GPB_MFP[11]	PB.11 function	
		0	0	GPIO	
		0	1	TM3	
		1	1	PWM4 (PWM)	
[10]	GPB_MFP10	<b>PB.10 Pin Function Selection</b> The pin function depends on GPB_MFP10 and PB10_S01 (ALT_MFP[0]).			
		PB10_S01	GPB_MFP[10]	PB.10 function	
		0	0	GPIO	
		0	1	TM2	
		1	1	SPISS01 (SPI0)	
[9]	GPB_MFP9	<b>PB.9 Pin Function Selection</b> The pin function depends on GPB_MFP9 and PB9_S11 (ALT_MFP[1]).			
		PB9_S11	GPB_MFP[9]	PB.9 function	
		0	0	GPIO	
		0	1	TM1	
		1	1	SPISS11 (SPI1)	
[8]	GPB_MFP8	<b>PB.8 Pin Function Selection</b> 1 = The TM0 (Timer/Counter external trigger clock input) function is selected to the pin PB.8 0 = The GPIOB[8] is selected to the pin PB.8			
[7]	GPB_MFP7	<b>PB.7 Pin Function Selection</b> The pin function depends on GPB_MFP7 and EBI_EN (ALT_MFP[11]).			
		EBI_EN	GPB_MFP[7]	PB.7 function	
		0	0	GPIO	
		0	1	CTS1 (UART1)	
		1	1	nCS (EBI)	
[6]	GPB_MFP6	<b>PB.6 Pin Function Selection</b> The pin function depends on GPB_MFP6 and EBI_EN (ALT_MFP[11]).			





Bits	Descriptions			
		EBI_EN	GPB_MFP[6]	PB.6 function
		0	0	GPIO
		0	1	RTS1 (UART1)
		1	1	ALE (EBI)
[5]	<b>GPB_MFP5</b>	<b>PB.5 Pin Function Selection</b> 1 = The UART1 TXD function is selected to the pin PB.5 0 = The GPIOB[5] is selected to the pin PB.5		
[4]	<b>GPB_MFP4</b>	<b>PB.4 Pin Function Selection</b> 1 = The UART1 RXD function is selected to the pin PB.4 0 = The GPIOB[4] is selected to the pin PB.4		
[3]	<b>GPB_MFP3</b>	<b>PB.3 Pin Function Selection</b> The pin function depends on GPB_MFP3 and EBI_nWRH_EN (ALT_MFP[14]) and EBI_EN (ALT_MFP[11]).		
		EBI_nWRH_EN	EBI_EN	GPB_MFP[3] PB.3 function
		0	0	GPIO
		0	0	CTS0 (UART0)
		1	1	nWRH (EBI write high byte enable)
[2]	<b>GPB_MFP2</b>	<b>PB.2 Pin Function Selection</b> The pin function depends on GPB_MFP2 and EBI_nWRL_EN (ALT_MFP[13]) and EBI_EN (ALT_MFP[11]).		
		EBI_nWRL_EN	EBI_EN	GPB_MFP[2] PB.2 function
		0	0	GPIO
		0	0	RTS0 (UART0)
		1	1	nWRL (EBI write low byte enable)
[1]	<b>GPB_MFP1</b>	<b>PB.1 Pin Function Selection</b> 1 = The UART0 TXD function is selected to the pin PB.1 0 = The GPIOB[1] is selected to the pin PB.1		
[0]	<b>GPB_MFP0</b>	<b>PB.0 Pin Function Selection</b> 1 = The UART0 RXD function is selected to the pin PB.0 0 = The GPIOB[0] is selected to the pin PB.0		



**Multiple Function Pin GPIOC Control Register (GPC\_MFP)**

Register	Offset	R/W	Description	Reset Value
GPC_MFP	GCR_BA+0x38	R/W	GPIOC Multiple Function and Input Type Control Register	0x0000_0000

31	30	29	28	27	26	25	24
GPC_TYPE[15:8]							
23	22	21	20	19	18	17	16
GPC_TYPE[7:0]							
15	14	13	12	11	10	9	8
GPC_MFP[15:8]							
7	6	5	4	3	2	1	0
GPC_MFP[7:0]							

Bits	Descriptions														
[31:16]	<b>GPC_TYPEn</b>	1 = Enable GPIOC[15:0] I/O input Schmitt Trigger function 0 = Disable GPIOC[15:0] I/O input Schmitt Trigger function													
[15]	<b>GPC_MFP15</b>	<p><b>PC.15 Pin Function Selection</b> The pin function depends on GPC_MFP15 and EBI_EN (ALT_MFP[11]).</p> <table border="1"> <thead> <tr> <th>EBI_EN</th> <th>GPC_MFP[15]</th> <th>PC.15 function</th> </tr> </thead> <tbody> <tr> <td>0</td> <td>0</td> <td>GPIO</td> </tr> <tr> <td>0</td> <td>1</td> <td>CPN1 (CMP)</td> </tr> <tr> <td>1</td> <td>1</td> <td>AD3 (EBI AD bus bit 3)</td> </tr> </tbody> </table>		EBI_EN	GPC_MFP[15]	PC.15 function	0	0	GPIO	0	1	CPN1 (CMP)	1	1	AD3 (EBI AD bus bit 3)
EBI_EN	GPC_MFP[15]	PC.15 function													
0	0	GPIO													
0	1	CPN1 (CMP)													
1	1	AD3 (EBI AD bus bit 3)													
[14]	<b>GPC_MFP14</b>	<p><b>PC.14 Pin Function Selection</b> The pin function depends on GPC_MFP14 and EBI_EN (ALT_MFP[11]).</p> <table border="1"> <thead> <tr> <th>EBI_EN</th> <th>GPC_MFP[14]</th> <th>PC.14 function</th> </tr> </thead> <tbody> <tr> <td>0</td> <td>0</td> <td>GPIO</td> </tr> <tr> <td>0</td> <td>1</td> <td>CPP1 (CMP)</td> </tr> <tr> <td>1</td> <td>1</td> <td>AD2 (EBI AD bus bit 2)</td> </tr> </tbody> </table>		EBI_EN	GPC_MFP[14]	PC.14 function	0	0	GPIO	0	1	CPP1 (CMP)	1	1	AD2 (EBI AD bus bit 2)
EBI_EN	GPC_MFP[14]	PC.14 function													
0	0	GPIO													
0	1	CPP1 (CMP)													
1	1	AD2 (EBI AD bus bit 2)													
[13]	<b>GPC_MFP13</b>	<p><b>PC.13 Pin Function Selection</b> 1 = The SPI1 MOSI1 (master output, slave input pin-1) function is selected to the pin PC.13 0 = The GPIOC[13] is selected to the pin PC.13</p>													
[12]	<b>GPC_MFP12</b>	<p><b>PC.12 Pin Function Selection</b> 1 = The SPI1 MISO1 (master input, slave output pin-1) function is selected to the pin PC.12</p>													



Bits	Descriptions																	
		0 = The GPIOC[12] is selected to the pin PC.12																
[11]	<b>GPC_MFP11</b>	<p><b>PC.11 Pin Function Selection</b></p> <p>1 = The SPI1 MOSI0 (master output, slave input pin-0) function is selected to the pin PC.11</p> <p>0 = The GPIOC[11] is selected to the pin PC.11</p>																
[10]	<b>GPC_MFP10</b>	<p><b>PC.10 Pin Function Selection</b></p> <p>1 = The SPI1 MISO0 (master input, slave output pin-0) function is selected to the pin PC.10</p> <p>0 = The GPIOC[10] is selected to the pin PC.10</p>																
[9]	<b>GPC_MFP9</b>	<p><b>PC.9 Pin Function Selection</b></p> <p>1 = The SPI1 SPICLK function is selected to the pin PC.9</p> <p>0 = The GPIOC[9] is selected to the pin PC.9</p>																
[8]	<b>GPC_MFP8</b>	<p><b>PC.8 Pin Function Selection</b></p> <p>The pin function depends on GPC_MFP8 and EBI_MCLK_EN (ALT_MFP[12]) and EBI_EN (ALT_MFP[11]).</p> <table border="1" style="width: 100%; border-collapse: collapse;"> <thead> <tr> <th style="text-align: center;">EBI_MCLK_EN</th> <th style="text-align: center;">EBI_EN</th> <th style="text-align: center;">GPC_MFP[8]</th> <th style="text-align: center;">PC.8 function</th> </tr> </thead> <tbody> <tr> <td style="text-align: center;">0</td> <td style="text-align: center;">0</td> <td style="text-align: center;">0</td> <td>GPIO</td> </tr> <tr> <td style="text-align: center;">0</td> <td style="text-align: center;">0</td> <td style="text-align: center;">1</td> <td>SPISS10 (SPI1)</td> </tr> <tr> <td style="text-align: center;">1</td> <td style="text-align: center;">1</td> <td style="text-align: center;">1</td> <td>MCLK (EBI Clock output)</td> </tr> </tbody> </table>	EBI_MCLK_EN	EBI_EN	GPC_MFP[8]	PC.8 function	0	0	0	GPIO	0	0	1	SPISS10 (SPI1)	1	1	1	MCLK (EBI Clock output)
EBI_MCLK_EN	EBI_EN	GPC_MFP[8]	PC.8 function															
0	0	0	GPIO															
0	0	1	SPISS10 (SPI1)															
1	1	1	MCLK (EBI Clock output)															
[7]	<b>GPC_MFP7</b>	<p><b>PC.7 Pin Function Selection</b></p> <p>The pin function depends on GPC_MFP7 and EBI_EN (ALT_MFP[11]).</p> <table border="1" style="width: 100%; border-collapse: collapse;"> <thead> <tr> <th style="text-align: center;">EBI_EN</th> <th style="text-align: center;">GPC_MFP[7]</th> <th style="text-align: center;">PC.7 function</th> </tr> </thead> <tbody> <tr> <td style="text-align: center;">0</td> <td style="text-align: center;">0</td> <td>GPIO</td> </tr> <tr> <td style="text-align: center;">0</td> <td style="text-align: center;">1</td> <td>CPN0 (CMP)</td> </tr> <tr> <td style="text-align: center;">1</td> <td style="text-align: center;">1</td> <td>AD5 (EBI AD bus bit 5)</td> </tr> </tbody> </table>	EBI_EN	GPC_MFP[7]	PC.7 function	0	0	GPIO	0	1	CPN0 (CMP)	1	1	AD5 (EBI AD bus bit 5)				
EBI_EN	GPC_MFP[7]	PC.7 function																
0	0	GPIO																
0	1	CPN0 (CMP)																
1	1	AD5 (EBI AD bus bit 5)																
[6]	<b>GPC_MFP6</b>	<p><b>PC.6 Pin Function Selection</b></p> <p>The pin function depends on GPC_MFP6 and EBI_EN (ALT_MFP[11]).</p> <table border="1" style="width: 100%; border-collapse: collapse;"> <thead> <tr> <th style="text-align: center;">EBI_EN</th> <th style="text-align: center;">GPC_MFP[6]</th> <th style="text-align: center;">PC.6 function</th> </tr> </thead> <tbody> <tr> <td style="text-align: center;">0</td> <td style="text-align: center;">0</td> <td>GPIO</td> </tr> <tr> <td style="text-align: center;">0</td> <td style="text-align: center;">1</td> <td>CPP0 (CMP)</td> </tr> <tr> <td style="text-align: center;">1</td> <td style="text-align: center;">1</td> <td>AD4 (EBI AD bus bit 4)</td> </tr> </tbody> </table>	EBI_EN	GPC_MFP[6]	PC.6 function	0	0	GPIO	0	1	CPP0 (CMP)	1	1	AD4 (EBI AD bus bit 4)				
EBI_EN	GPC_MFP[6]	PC.6 function																
0	0	GPIO																
0	1	CPP0 (CMP)																
1	1	AD4 (EBI AD bus bit 4)																
[5]	<b>GPC_MFP5</b>	<p><b>PC.5 Pin Function Selection</b></p> <p>1 = The SPI0 MOSI1 (master output, slave input pin-1) function is selected to the pin PC.5</p> <p>0 = The GPIOC[5] is selected to the pin PC.5</p>																
[4]	<b>GPC_MFP4</b>	<p><b>PC.4 Pin Function Selection</b></p> <p>1 = The SPI0 MISO1 (master input, slave output pin-1) function is selected to the pin</p>																



Bits	Descriptions														
		PC.4 0 = The GPIOC[4] is selected to the pin PC.4													
[3]	<b>GPC_MFP3</b>	<b>PC.3 Pin Function Selection</b> Bits PC3_I2SDO (ALT_MFP[8]) and GPC_MFP[3] determine the PC.3 function. <table border="1" style="width: 100%; margin-top: 5px;"> <thead> <tr> <th style="text-align: center;">PC3_I2SDO</th> <th style="text-align: center;">GPC_MFP[3]</th> <th style="text-align: center;">PC.3 function</th> </tr> </thead> <tbody> <tr> <td style="text-align: center;">0</td> <td style="text-align: center;">0</td> <td>GPIO</td> </tr> <tr> <td style="text-align: center;">0</td> <td style="text-align: center;">1</td> <td>MOSI00 (SPI0)</td> </tr> <tr> <td style="text-align: center;">1</td> <td style="text-align: center;">1</td> <td>I2SDO (I<sup>2</sup>S)</td> </tr> </tbody> </table>		PC3_I2SDO	GPC_MFP[3]	PC.3 function	0	0	GPIO	0	1	MOSI00 (SPI0)	1	1	I2SDO (I <sup>2</sup> S)
PC3_I2SDO	GPC_MFP[3]	PC.3 function													
0	0	GPIO													
0	1	MOSI00 (SPI0)													
1	1	I2SDO (I <sup>2</sup> S)													
[2]	<b>GPC_MFP2</b>	<b>PC.2 Pin Function Selection</b> Bits PC2_I2SDI (ALT_MFP[7]) and GPC_MFP[2] determine the PC.2 function. <table border="1" style="width: 100%; margin-top: 5px;"> <thead> <tr> <th style="text-align: center;">PC2_I2SDI</th> <th style="text-align: center;">GPC_MFP[2]</th> <th style="text-align: center;">PC.2 function</th> </tr> </thead> <tbody> <tr> <td style="text-align: center;">0</td> <td style="text-align: center;">0</td> <td>GPIO</td> </tr> <tr> <td style="text-align: center;">0</td> <td style="text-align: center;">1</td> <td>MISO00 (SPI0)</td> </tr> <tr> <td style="text-align: center;">1</td> <td style="text-align: center;">1</td> <td>I2SDI (I<sup>2</sup>S)</td> </tr> </tbody> </table>		PC2_I2SDI	GPC_MFP[2]	PC.2 function	0	0	GPIO	0	1	MISO00 (SPI0)	1	1	I2SDI (I <sup>2</sup> S)
PC2_I2SDI	GPC_MFP[2]	PC.2 function													
0	0	GPIO													
0	1	MISO00 (SPI0)													
1	1	I2SDI (I <sup>2</sup> S)													
[1]	<b>GPC_MFP1</b>	<b>PC.1 Pin Function Selection</b> Bits PC1_I2SBCLK (ALT_MFP[6]) and GPC_MFP[1] determine the PC.1 function. <table border="1" style="width: 100%; margin-top: 5px;"> <thead> <tr> <th style="text-align: center;">PC1_I2SBCLK</th> <th style="text-align: center;">GPC_MFP[1]</th> <th style="text-align: center;">PC.1 function</th> </tr> </thead> <tbody> <tr> <td style="text-align: center;">0</td> <td style="text-align: center;">0</td> <td>GPIO</td> </tr> <tr> <td style="text-align: center;">0</td> <td style="text-align: center;">1</td> <td>SPICLK0 (SPI0)</td> </tr> <tr> <td style="text-align: center;">1</td> <td style="text-align: center;">1</td> <td>I2SBCLK (I<sup>2</sup>S)</td> </tr> </tbody> </table>		PC1_I2SBCLK	GPC_MFP[1]	PC.1 function	0	0	GPIO	0	1	SPICLK0 (SPI0)	1	1	I2SBCLK (I <sup>2</sup> S)
PC1_I2SBCLK	GPC_MFP[1]	PC.1 function													
0	0	GPIO													
0	1	SPICLK0 (SPI0)													
1	1	I2SBCLK (I <sup>2</sup> S)													
[0]	<b>GPC_MFP0</b>	<b>PC.0 Pin Function Selection</b> Bits PC0_I2SLRCLK (ALT_MFP[5]) and GPC_MFP[0] determine the PC.0 function. <table border="1" style="width: 100%; margin-top: 5px;"> <thead> <tr> <th style="text-align: center;">PC0_I2SLRCLK</th> <th style="text-align: center;">GPC_MFP[0]</th> <th style="text-align: center;">PC.0 function</th> </tr> </thead> <tbody> <tr> <td style="text-align: center;">0</td> <td style="text-align: center;">0</td> <td>GPIO</td> </tr> <tr> <td style="text-align: center;">0</td> <td style="text-align: center;">1</td> <td>SPISS00 (SPI0)</td> </tr> <tr> <td style="text-align: center;">1</td> <td style="text-align: center;">1</td> <td>I2SLRCLK (I<sup>2</sup>S)</td> </tr> </tbody> </table>		PC0_I2SLRCLK	GPC_MFP[0]	PC.0 function	0	0	GPIO	0	1	SPISS00 (SPI0)	1	1	I2SLRCLK (I <sup>2</sup> S)
PC0_I2SLRCLK	GPC_MFP[0]	PC.0 function													
0	0	GPIO													
0	1	SPISS00 (SPI0)													
1	1	I2SLRCLK (I <sup>2</sup> S)													



## Multiple Function Pin GPIO Control Register (GPD\_MFP)

Register	Offset	R/W	Description	Reset Value
GPD_MFP	GCR_BA+0x3C	R/W	GPIO Multiple Function and Input Type Control Register	0x0000_0000

31	30	29	28	27	26	25	24
<b>GPD_TYPE[15:8]</b>							
23	22	21	20	19	18	17	16
<b>GPD_TYPE[7:0]</b>							
15	14	13	12	11	10	9	8
<b>GPD_MFP[15:8]</b>							
7	6	5	4	3	2	1	0
<b>GPD_MFP[7:0]</b>							

Bits	Descriptions	
[31:16]	<b>GPD_TYPEn</b>	1 = Enable GPIO[15:0] I/O input Schmitt Trigger function 0 = Disable GPIO[15:0] I/O input Schmitt Trigger function
[15]	<b>GPD_MFP15</b>	<b>PD.15 Pin Function Selection</b> (NuMicro™ NUC100/NUC120 Medium Density Only) 1 = The UART2 TXD function is selected to the pin PD.15 0 = The GPIO[15] selected to the pin PD.15
[14]	<b>GPD_MFP14</b>	<b>PD.14 Pin Function Selection</b> (NuMicro™ NUC100/NUC120 Medium Density Only) 1 = The UART2 RXD function is selected to the pin PD.14 0 = The GPIO[14] selected to the pin PD.14
[13]	<b>GPD_MFP13</b>	<b>PD.13 Pin Function Selection</b> (NuMicro™ NUC100/NUC120 Medium Density Only) 1 = The SPI3 MOSI1 (master output, slave input pin-1) function is selected to the pin PD.13 0 = The GPIO[13] is selected to the pin PD.13
[12]	<b>GPD_MFP12</b>	<b>PD.12 Pin Function Selection</b> (NuMicro™ NUC100/NUC120 Medium Density Only) 1 = The SPI3 MISO1 (master input, slave output pin-1) function is selected to the pin PD.12 0 = The GPIO[12] is selected to the pin PD.12
[11]	<b>GPD_MFP11</b>	<b>PD.11 Pin Function Selection</b> (NuMicro™ NUC100/NUC120 Medium Density Only) 1 = The SPI3 MOSI0 (master output, slave input pin-0) function is selected to the pin PD.11 0 = The GPIO[11] is selected to the pin PD.11
[10]	<b>GPD_MFP10</b>	<b>PD.10 Pin Function Selection</b> (NuMicro™ NUC100/NUC120 Medium Density Only) 1 = The SPI3 MISO0 (master input, slave output pin-0) function is selected to the pin PD.10 0 = The GPIO[10] is selected to the pin PD.10



Bits	Descriptions	
		0 = The GPIOD[10] is selected to the pin PD.10
[9]	<b>GPD_MFP9</b>	<b>PD.9 Pin Function Selection</b> (NuMicro™ NUC100/NUC120 Medium Density Only) 1 = The SPI3 SPICLK function is selected to the pin PD.9 0 = The GPIOD[9] is selected to the pin PD.9
[8]	<b>GPD_MFP8</b>	<b>PD.8 Pin Function Selection</b> (NuMicro™ NUC100/NUC120 Medium Density Only) 1 = The SPI3 SS30 function is selected to the pin PD8 0 = The GPIOD[8] is selected to the pin PD8
[7]	<b>GPD_MFP7</b>	Reserved
[6]	<b>GPD_MFP6</b>	Reserved
[5]	<b>GPD_MFP5</b>	<b>PD.5 Pin Function Selection</b> (NuMicro™ NUC100/NUC120 Medium Density Only) 1 = The SPI2 MOSI1 (master output, slave input pin-1) function is selected to the pin PD.5 0 = The GPIOD[5] is selected to the pin PD.5
[4]	<b>GPD_MFP4</b>	<b>PD.4 Pin Function Selection</b> (NuMicro™ NUC100/NUC120 Medium Density Only) 1 = The SPI2 MISO1 (master input, slave output pin-1) function is selected to the pin PD.4 0 = The GPIOD[4] is selected to the pin PD.4
[3]	<b>GPD_MFP3</b>	<b>PD.3 Pin Function Selection</b> For NuMicro™ NUC100/NUC120 Medium Density 1 = The SPI2 MOSI0 (master output, slave input pin-0) function is selected to the pin PD.3 0 = The GPIOD[3] is selected to the pin PD.3 For NuMicro™ NUC100/NUC120 Low Density Reserved
[2]	<b>GPD_MFP2</b>	<b>PD.2 Pin Function Selection</b> For NuMicro™ NUC100/NUC120 Medium Density 1 = The SPI2 MISO0 (master input, slave output pin-0) function is selected to the pin PD.2 0 = The GPIOD[2] is selected to the pin PD.2 For NuMicro™ NUC100/NUC120 Low Density Reserved
[1]	<b>GPD_MFP1</b>	<b>PD.1 Pin Function Selection</b> For NuMicro™ NUC100/NUC120 Medium Density 1 = The SPI2 SPICLK function is selected to the pin PD.1 0 = The GPIOD[1] is selected to the pin PD.1 For NuMicro™ NUC100/NUC120 Low Density Reserved
[0]	<b>GPD_MFP0</b>	<b>PD.0 Pin Function Selection</b> (NuMicro™ NUC100/NUC120 Medium Density Only) 1 = The SPI2 SS20 function is selected to the pin PD.0 0 = The GPIOD[0] is selected to the pin PD.0



## Multiple Function Pin GPIOE Control Register (GPE\_MFP)

Register	Offset	R/W	Description	Reset Value
GPE_MFP	GCR_BA+0x40	R/W	GPIOE Multiple Function and Input Type Control Register	0x0000_0000

In this register, NuMicro™ NUC100/NUC120 Low Density only has GPE\_TYPE5 register bit

31	30	29	28	27	26	25	24
<b>GPE_TYPE[15:8]</b>							
23	22	21	20	19	18	17	16
<b>GPE_TYPE[7:0]</b>							
15	14	13	12	11	10	9	8
<b>Reserved</b>							
7	6	5	4	3	2	1	0
<b>Reserved</b>		<b>GPE_MFP5</b>	<b>Reserved</b>			<b>GPE_MFP1</b>	<b>GPE_MFP0</b>

Bits	Descriptions	
[31:16]	<b>GPE_TYPEn</b>	1 = Enable GPIOE[15:0] I/O input Schmitt Trigger function 0 = Disable GPIOE[15:0] I/O input Schmitt Trigger function Note: In this field, NuMicro™ NUC100/NUC120 Low Density only has GPE_TYPE5 bit
[15:6]	<b>Reserved</b>	Reserved
[5]	<b>GPE_MFP5</b>	<b>PE.5 Pin Function Selection</b> (NuMicro™ NUC100/NUC120 Medium Density Only) 1 = The PWM5 function is selected to the pin PE.5 0 = The GPIOE[5] is selected to the pin PE.5
[4:2]	<b>Reserved</b>	Reserved
[1]	<b>GPE_MFP1</b>	<b>PE.1 Pin Function Selection</b> (NuMicro™ NUC100/NUC120 Medium Density Only) 1 = The PWM7 function is selected to the pin PE.1 0 = The GPIOE[1] is selected to the pin PE.1
[0]	<b>GPE_MFP0</b>	<b>PE.0 Pin Function Selection</b> (NuMicro™ NUC100/NUC120 Medium Density Only) 1 = The PWM6 function is selected to the pin PE.0 0 = The GPIOE[0] is selected to the pin PE.0



**Alternative Multiple Function Pin Control Register (ALT\_MFP)**

Register	Offset	R/W	Description	Reset Value
ALT_MFP	GCR_BA+0x50	R/W	Alternative Multiple Function Pin Control Register	0x0000_0000

31	30	29	28	27	26	25	24
Reserved							
23	22	21	20	19	18	17	16
EBI_HB_EN							
15	14	13	12	11	10	9	8
Reserved	EBI_nWRH_EN	EBI_nWRL_EN	EBI_MCLK_EN	EBI_EN	PB12_CLKO	PA15_I2SMCLK	PC3_I2SDO
7	6	5	4	3	2	1	0
PC2_I2SDI	PC1_I2SBCLK	PC0_I2SLRLK	PB11_PWM4	PB14_S31	PA7_S21	PB9_S11	PB10_S01

Bits	Descriptions				
[31:24]	Reserved		Reserved		
[23]	EBI_HB_EN[7]	EBI_HB_EN is use to switch GPIO function to EBI address/data bus high byte (AD[15:8]), EBI_HB_EN, EBI_EN and corresponding GPx_MFP[y] determine the Px.y function. Bits EBI_HB_EN[7], EBI_EN and GPA_MFP[14] determine the PA.14 function.			
		EBI_HB_EN[7]	EBI_EN	GPA_MFP[14]	PA.14 function
		0	0	0	GPIO
		0	0	1	PWM2 (PWM)
[22]	EBI_HB_EN[6]	Bits EBI_HB_EN[6], EBI_EN and GPA_MFP[13] determine the PA.13 function.			
		EBI_HB_EN[6]	EBI_EN	GPA_MFP[13]	PA.13 function
		0	0	0	GPIO
		0	0	1	PWM1 (PWM)
[21]	EBI_HB_EN[5]	Bits EBI_HB_EN[5], EBI_EN and GPA_MFP[12] determine the PA.12 function.			
		EBI_HB_EN[5]	EBI_EN	GPA_MFP[12]	PA.12 function
		0	0	0	GPIO
		0	0	1	PWM0 (PWM)





Bits	Descriptions				
		1	1	1	AD13 (EBI AD bus bit 13)
[20]	<b>EBI_HB_EN[4]</b>	Bits EBI_HB_EN[4], EBI_EN and GPA_MFP[1] determine the PA.1 function.			
		EBI_HB_EN[4]	EBI_EN	GPA_MFP[1]	PA.1 function
		0	0	0	GPIO
		0	0	1	ADC1 (ADC)
		1	1	1	AD12 (EBI AD bus bit 12)
[19]	<b>EBI_HB_EN[3]</b>	Bits EBI_HB_EN[3], EBI_EN and GPA_MFP[2] determine the PA.2 function.			
		EBI_HB_EN[3]	EBI_EN	GPA_MFP[2]	PA.2 function
		0	0	0	GPIO
		0	0	1	ADC2 (ADC)
		1	1	1	AD11 (EBI AD bus bit 11)
[18]	<b>EBI_HB_EN[2]</b>	Bits EBI_HB_EN[2], EBI_EN and GPA_MFP[3] determine the PA.3 function.			
		EBI_HB_EN[2]	EBI_EN	GPA_MFP[3]	PA.3 function
		0	0	0	GPIO
		0	0	1	ADC3 (ADC)
		1	1	1	AD10 (EBI AD bus bit 10)
[17]	<b>EBI_HB_EN[1]</b>	Bits EBI_HB_EN[1], EBI_EN and GPA_MFP[4] determine the PA.4 function.			
		EBI_HB_EN[1]	EBI_EN	GPA_MFP[4]	PA.4 function
		0	0	0	GPIO
		0	0	1	ADC4 (ADC)
		1	1	1	AD9 (EBI AD bus bit 9)
[16]	<b>EBI_HB_EN[0]</b>	Bits EBI_HB_EN[0], EBI_EN and GPA_MFP[5] determine the PA.5 function.			
		EBI_HB_EN[0]	EBI_EN	GPA_MFP[5]	PA.5 function
		0	0	0	GPIO
		0	0	1	ADC5 (ADC)
		1	1	1	AD8 (EBI AD bus bit 8)
[15]	<b>Reserved</b>	Reserved			
[14]	<b>EBI_nWRH_EN</b>	Bits EBI_nWRH_EN, EBI_EN and GPB_MFP[3] determine the PB.3 function.			
		EBI_nWRH_EN	EBI_EN	GPB_MFP[3]	PB.3 function
		0	0	0	GPIO
		0	0	1	CTS0 (UART0)
		1	1	1	nWRH (EBI write high byte enable)



Bits	Descriptions				
[13]	<b>EBI_nWRL_EN</b>	Bits EBI_nWRL_EN, EBI_EN and GPB_MFP[2] determine the PB.2 function.			
		EBI_nWRL_EN	EBI_EN	GPB_MFP[2]	PB.2 function
		0	0	0	GPIO
		0	0	1	RTS0 (UART0)
		1	1	nWRL (EBI write low byte enable)	
[12]	<b>EBI_MCLK_EN</b>	Bits EBI_MCLK_EN, EBI_EN and GPC_MFP[8] determine the PC.8 function.			
		EBI_MCLK_EN	EBI_EN	GPC_MFP[8]	PC.8 function
		0	0	0	GPIO
		0	0	1	SPISS10 (SPI1)
		1	1	MCLK (EBI Clock output)	
[11]	<b>EBI_EN</b>	EBI_EN is use to switch GPIO function to EBI function (AD[15:0], ALE, RE, WE, CS, MCLK), it need additional registers EBI_EN[7:0] and EBI_MCLK_EN for some GPIO to switch to EBI function(AD[15:8], MCLK)			
		EBI_EN	GPA_MFP[6]	PA.6 function	
		0	0	GPIO	
		0	1	ADC5 (ADC)	
		1	1	AD7 (EBI AD bus bit 7)	
		EBI_EN	GPA_MFP[7]	PA.7 function	
		0	0	GPIO	
		0	1	ADC7 (ADC)	
		1	1	AD6 (EBI AD bus bit 6)	
		EBI_EN	GPC_MFP[7]	PC.7 function	
		0	0	GPIO	
		0	1	CPN0 (CMP)	
		1	1	AD5 (EBI AD bus bit 5)	
		EBI_EN	GPC_MFP[6]	PC.6 function	
		0	0	GPIO	
		0	1	CPP0 (CMP)	
		1	1	AD4 (EBI AD bus bit 4)	



Bits	Descriptions			
	EBI_EN	GPC_MFP[15]	PC.15 function	
	0	0	GPIO	
	0	1	CPN1 (CMP)	
	1	1	AD3 (EBI AD bus bit 3)	
	EBI_EN	GPC_MFP[14]	PC.14 function	
	0	0	GPIO	
	0	1	CPP1 (CMP)	
	1	1	AD2 (EBI AD bus bit 2)	
	EBI_EN	GPB_MFP[13]	PB.13 function	
	0	0	GPIO	
	0	1	CPO1 (CMP)	
	1	1	AD1 (EBI AD bus bit 1)	
	EBI_EN	PB12_CLKO	GPB_MFP[12]	PB.12 function
	0	0	0	GPIO
	0	0	1	CPO0 (CMP)
	0	1	1	CLKO (Clock Driver output)
	1	1	1	AD0 (EBI AD bus bit 0)
	EBI_EN	GPA_MFP[11]	PA.11 function	
	0	0	GPIO	
	0	1	SCL1 (I <sup>2</sup> C)	
	1	1	nRD (EBI)	
	EBI_EN	GPA_MFP[10]	PA.10 function	
	0	0	GPIO	
	0	1	SDA1 (I <sup>2</sup> C)	
	1	1	nWR (EBI)	
	EBI_EN	GPB_MFP[6]	PB.6 function	
	0	0	GPIO	



Bits	Descriptions				
		0	1	RTS1 (UART1)	
		1	1	ALE (EBI)	
		EBI_EN	GPB_MFP[7]	PB.7 function	
		0	0	GPIO	
		0	1	CTS1 (UART1)	
		1	1	nCS (EBI)	
[10]	<b>PB12_CLKO</b>	Bits PB12_CLKO, GPB_MFP[12] and EBI_EN (ALT_MFP[11]) determine the PB.12 function.			
		EBI_EN	PB12_CLKO	GPB_MFP[12]	PB.12 function
		0	0	0	GPIO
		0	0	1	CPO0 (CMP)
		0	1	1	CLKO (Clock Driver output)
		1	1	1	AD0 (EBI AD bus bit 0)
[9]	<b>PA15_I2SMCLK</b>	Bits PA15_I2SMCLK and GPA_MFP[15] determine the PA.15 function.			
		PA15_I2SMCLK	GPA_MFP[15]	PA.15 function	
		0	0	GPIO	
		0	1	PWM3 (PWM)	
		1	1	I2SMCLK (I <sup>2</sup> S)	
[8]	<b>PC3_I2SDO</b>	Bits PC3_I2SDO and GPC_MFP[3] determine the PC.3 function.			
		PC3_I2SDO	GPC_MFP[3]	PC.3 function	
		0	0	GPIO	
		0	1	MOSI00 (SPI0)	
		1	1	I2SDO (I <sup>2</sup> S)	
[7]	<b>PC2_I2SDI</b>	Bits PC2_I2SDI and GPC_MFP[2] determine the PC.2 function.			
		PC2_I2SDI	GPC_MFP[2]	PC.2 function	
		0	0	GPIO	
		0	1	MISO00 (SPI0)	
		1	1	I2SDI (I <sup>2</sup> S)	
[6]	<b>PC1_I2SBCLK</b>	Bits PC1_I2SBCLK and GPC_MFP[1] determine the PC.1 function.			
		PC1_I2SBCLK	GPC_MFP[1]	PC.1 function	
		0	0	GPIO	
		0	1	SPICK0 (SPI0)	



Bits	Descriptions				
		1	1	I2SBCLK (I <sup>2</sup> S)	
[5]	<b>PC0_I2SLRCLK</b>	Bits PC0_I2SLRCLK and GPC_MFP[0] determine the PC.0 function.			
		PC0_I2SLRCLK	GPC_MFP[0]	PC.0 function	
		0	0	GPIO	
		0	1	SPISS00 (SPI0)	
		1	1	I2SLRCLK (I <sup>2</sup> S)	
[4]	<b>PB11_PWM4</b>	Bits PB11_PWM4 and GPB_MFP[11] determine the PB.11 function.			
		PB11_PWM4	GPB_MFP[11]	PB.11 function	
		0	0	GPIO	
		0	1	TM3	
		1	1	PWM4 (PWM)	
[3]	<b>PB14_S31</b>	Bits PB14_S31 and GPB_MFP[14] determine the PB.14 function.			
		PB14_S31	GPB_MFP[14]	PB.14 function	
		0	0	GPIO	
		0	1	/INT0	
		1	1	SPISS31 (SPI3)	
[2]	<b>PA7_S21</b>	Bits PA7_S21, GPA_MFP[7] and EBI_EN (ALT_MFP[11]).determine the PA.7 function.			
		EBI_EN	PA7_S21	GPA_MFP[7]	PA.7 function
		0	0	0	GPIO
		0	0	1	ADC7 (ADC)
		0	1	1	SPISS21 (SPI2)
		1	0	1	AD6 (EBI AD bus bit 6)
[1]	<b>PB9_S11</b>	Bits PB9_S11 and GPB_MFP[9] determine the PB.9 function.			
		PB9_S11	GPB_MFP[9]	PB.9 function	
		0	0	GPIO	
		0	1	TM1	
		1	1	SPISS11 (SPI1)	
[0]	<b>PB10_S01</b>	Bits PB10_S01 and GPB_MFP[10] determine the PB.10 function.			
		PB10_S01	GPB_MFP[10]	PB.10 function	
		0	0	GPIO	
		0	1	TM2	
		1	1	SPISS01 (SPI0)	



## Register Write-Protection Control Register (REGWRPROT)

Some of the system control registers need to be protected to avoid inadvertent write and disturb the chip operation. These system control registers are protected after the power on reset till user to disable register protection. For user to program these protected registers, a register protection disable sequence needs to be followed by a special programming. The register protection disable sequence is writing the data “59h”, “16h” “88h” to the register REGWRPROT address at 0x5000\_0100 continuously. Any different data value, different sequence or any other write to other address during these three data writing will abort the whole sequence.

After the protection is disabled, user can check the protection disable bit at address 0x5000\_0100 bit0, 1 is protection disable, and 0 is protection enable. Then user can update the target protected register value and then write any data to the address “0x5000\_0100” to enable register protection.

This register is write for disable/enable register protection and read for the REGPROTDIS status

Register	Offset	R/W	Description	Reset Value
REGWRPROT	GCR_BA+0x100	R/W	Register Write-Protection Control Register	0x0000_0000

31	30	29	28	27	26	25	24
Reserved							
23	22	21	20	19	18	17	16
Reserved							
15	14	13	12	11	10	9	8
Reserved							
7	6	5	4	3	2	1	0
REGWRPROT[7:1]							REGWRPROT [0]
							REGPROTDIS

Bits	Descriptions	
[31:16]	Reserved	Reserved
[7:0]	REGWRPROT	<b>Register Write-Protection Code</b> (Write Only) Some registers have write-protection function. Writing these registers have to disable the protected function by writing the sequence value “59h”, “16h”, “88h” to this field. After this sequence is completed, the REGPROTDIS bit will be set to 1 and write-protection registers can be normal write.
[0]	REGPROTDIS	<b>Register Write-Protection Disable index</b> (Read only) 1 = Write-protection is disabled for writing protected registers 0 = Write-protection is enabled for writing protected registers. Any write to the protected register is ignored.  The Protected registers are: <b>IPRSTC1</b> : address 0x5000_0008

	<p><b>CPR:</b> address 0x5000_0010 (Low Density only)</p> <p><b>BODCR:</b> address 0x5000_0018</p> <p><b>PORCR:</b> address 0x5000_0024</p> <p><b>PWRCON:</b> address 0x5000_0200 (bit[6] is not protected for power wake-up interrupt clear)</p> <p><b>APBCLK bit[0]:</b> address 0x5000_0208 (bit[0] is watchdog clock enable)</p> <p><b>CLKSEL0:</b> address 0x5000_0210 (for HCLK and CPU STCLK clock source select)</p> <p><b>CLKSEL1 bit[1:0]:</b> address 0x5000_0214 (for watchdog clock source select)</p> <p><b>ISPCON:</b> address 0x5000_C000 (Flash ISP Control register)</p> <p><b>ISPTRG:</b> address 0x5000_C010 (ISP Trigger Control register)</p> <p><b>WTCR:</b> address 0x4000_4000</p> <p><b>FATCON:</b> address 0x5000_C018</p>
--	---

## 5.2.6 System Timer (SysTick)

The Cortex-M0 includes an integrated system timer, SysTick. SysTick provides a simple, 24-bit clear-on-write, decrementing, wrap-on-zero counter with a flexible control mechanism. The counter can be used as a Real Time Operating System (RTOS) tick timer or as a simple counter.

When system timer is enabled, it will count down from the value in the SysTick Current Value Register (SYST\_CVR) to zero, and reload (wrap) to the value in the SysTick Reload Value Register (SYST\_RVR) on the next clock cycle, then decrement on subsequent clocks. When the counter transitions to zero, the COUNTFLAG status bit is set. The COUNTFLAG bit clears on reads.

The SYST\_CVR value is UNKNOWN on reset. Software should write to the register to clear it to zero before enabling the feature. This ensures the timer will count from the SYST\_RVR value rather than an arbitrary value when it is enabled.

If the SYST\_RVR is zero, the timer will be maintained with a current value of zero after it is reloaded with this value. This mechanism can be used to disable the feature independently from the timer enable bit.

For more detailed information, please refer to the documents “ARM® Cortex™-M0 Technical Reference Manual” and “ARM® v6-M Architecture Reference Manual”.





## 5.2.6.1 System Timer Control Register Map

R: read only, W: write only, R/W: both read and write

Register	Offset	R/W	Description	Reset Value
<b>SCS_BA = 0xE000_E000</b>				
<b>SYST_CSR</b>	SCS_BA+0x10	R/W	SysTick Control and Status Register	0x0000_0000
<b>SYST_RVR</b>	SCS_BA+0x14	R/W	SysTick Reload value Register	0xFFFF_FFFF
<b>SYST_CVR</b>	SCS_BA+0x18	R/W	SysTick Current value Register	0xFFFF_FFFF



## 5.2.6.2 System Timer Control Register Description

### SysTick Control and Status Register (SYST\_CSR)

Register	Offset	R/W	Description	Reset Value
SYST_CSR	SCS_BA+0x10	R/W	SysTick Control and Status Register	0x0000_0000

31	30	29	28	27	26	25	24
Reserved							
23	22	21	20	19	18	17	16
Reserved							COUNTFLAG
15	14	13	12	11	10	9	8
Reserved							
7	6	5	4	3	2	1	0
Reserved					CLKSRC	TICKINT	ENABLE

Bits	Descriptions	
[31:17]	Reserved	Reserved
[16]	COUNTFLAG	Returns 1 if timer counted to 0 since last time this register was read. COUNTFLAG is set by a count transition from 1 to 0. COUNTFLAG is cleared on read or by a write to the Current Value register.
[15:3]	Reserved	Reserved
[2]	CLKSRC	1 = Core clock used for SysTick. 0 = Clock source is (optional) external reference clock
[1]	TICKINT	1 = Counting down to 0 will cause the SysTick exception to be pended. Clearing the SysTick Current Value register by a register write in software will not cause SysTick to be pended. 0 = Counting down to 0 does not cause the SysTick exception to be pended. Software can use COUNTFLAG to determine if a count to zero has occurred.
[0]	ENABLE	1 = The counter will operate in a multi-shot manner 0 = The counter is disabled



## SysTick Reload Value Register (SYST\_RVR)

Register	Offset	R/W	Description	Reset Value
SYST_RVR	SCS_BA+0x14	R/W	SysTick Reload Value Register	0xFFFF_FFFF

31	30	29	28	27	26	25	24
Reserved							
23	22	21	20	19	18	17	16
RELOAD[23:16]							
15	14	13	12	11	10	9	8
RELOAD[15:8]							
7	6	5	4	3	2	1	0
RELOAD[7:0]							

Bits	Descriptions	
[31:24]	Reserved	Reserved
[23:0]	RELOAD	Value to load into the Current Value register when the counter reaches 0.



## SysTick Current Value Register (SYST\_CVR)

Register	Offset	R/W	Description	Reset Value
SYST_CVR	SCS_BA+0x18	R/W	SysTick Current Value Register	0xFFFF_XXXX

31	30	29	28	27	26	25	24
Reserved							
23	22	21	20	19	18	17	16
CURRENT [23:16]							
15	14	13	12	11	10	9	8
CURRENT [15:8]							
7	6	5	4	3	2	1	0
CURRENT[7:0]							

Bits	Descriptions	
[31:24]	<b>Reserved</b>	Reserved
[23:0]	<b>CURRENT</b>	Current counter value. This is the value of the counter at the time it is sampled. The counter does not provide read-modify-write protection. The register is write-clear. A software write of any value will clear the register to 0.

### 5.2.7 Nested Vectored Interrupt Controller (NVIC)

Cortex-M0 provides an interrupt controller as an integral part of the exception mode, named as “Nested Vectored Interrupt Controller (NVIC)”. It is closely coupled to the processor kernel and provides following features:

- Nested and Vectored interrupt support
- Automatic processor state saving and restoration
- Reduced and deterministic interrupt latency

The NVIC prioritizes and handles all supported exceptions. All exceptions are handled in “Handler Mode”. This NVIC architecture supports 32 (IRQ[31:0]) discrete interrupts with 4 levels of priority. All of the interrupts and most of the system exceptions can be configured to different priority levels. When an interrupt occurs, the NVIC will compare the priority of the new interrupt to the current running one’s priority. If the priority of the new interrupt is higher than the current one, the new interrupt handler will override the current handler.

When any interrupts is accepted, the starting address of the interrupt service routine (ISR) is fetched from a vector table in memory. There is no need to determine which interrupt is accepted and branch to the starting address of the correlated ISR by software. While the starting address is fetched, NVIC will also automatically save processor state including the registers “PC, PSR, LR, R0~R3, R12” to the stack. At the end of the ISR, the NVIC will restore the mentioned registers from stack and resume the normal execution. Thus it will take less and deterministic time to process the interrupt request.

The NVIC supports “Tail Chaining” which handles back-to-back interrupts efficiently without the overhead of states saving and restoration and therefore reduces delay time in switching to pending ISR at the end of current ISR. The NVIC also supports “Late Arrival” which improves the efficiency of concurrent ISRs. When a higher priority interrupt request occurs before the current ISR starts to execute (at the stage of state saving and starting address fetching), the NVIC will give priority to the higher one without delay penalty. Thus it advances the real-time capability.

For more detailed information, please refer to the documents “ARM® Cortex™-M0 Technical Reference Manual” and “ARM® v6-M Architecture Reference Manual”.



## 5.2.7.1 Exception Model and System Interrupt Map

Table 5-2 lists the exception model supported by NuMicro™ NUC100 Series. Software can set four levels of priority on some of these exceptions as well as on all interrupts. The highest user-configurable priority is denoted as “0” and the lowest priority is denoted as “3”. The default priority of all the user-configurable interrupts is “0”. Note that priority “0” is treated as the fourth priority on the system, after three system exceptions “Reset”, “NMI” and “Hard Fault”.

Exception Name	Vector Number	Priority
Reset	1	-3
NMI	2	-2
Hard Fault	3	-1
Reserved	4 ~ 10	Reserved
SVCall	11	Configurable
Reserved	12 ~ 13	Reserved
PendSV	14	Configurable
SysTick	15	Configurable
Interrupt (IRQ0 ~ IRQ31)	16 ~ 47	Configurable

Table 5-2 Exception Model

Vector Number	Interrupt Number (Bit in Interrupt Registers)	Interrupt Name	Source IP	Interrupt description
0 ~ 15	-	-	-	System exceptions
16	0	<b>BOD_OUT</b>	Brown-Out	Brown-Out low voltage detected interrupt
17	1	<b>WDT_INT</b>	WDT	Watchdog Timer interrupt
18	2	<b>EINT0</b>	GPIO	External signal interrupt from PB.14 pin
19	3	<b>EINT1</b>	GPIO	External signal interrupt from PB.15 pin
20	4	<b>GPAB_INT</b>	GPIO	External signal interrupt from PA[15:0]/PB[13:0]
21	5	<b>GPCDE_INT</b>	GPIO	External interrupt from PC[15:0]/PD[15:0]/PE[15:0]
22	6	<b>PWMA_INT</b>	PWM0~3	PWM0, PWM1, PWM2 and PWM3 interrupt
23	7	<b>PWMB_INT</b>	PWM4~7	PWM4, PWM5, PWM6 and PWM7 interrupt
24	8	<b>TMR0_INT</b>	TMR0	Timer 0 interrupt
25	9	<b>TMR1_INT</b>	TMR1	Timer 1 interrupt



Vector Number	Interrupt Number (Bit in Interrupt Registers)	Interrupt Name	Source IP	Interrupt description
26	10	TMR2_INT	TMR2	Timer 2 interrupt
27	11	TMR3_INT	TMR3	Timer 3 interrupt
28	12	UART02_INT	UART0/2	UART0 and UART2 interrupt
29	13	UART1_INT	UART1	UART1 interrupt
30	14	SPI0_INT	SPI0	SPI0 interrupt
31	15	SPI1_INT	SPI1	SPI1 interrupt
32	16	SPI2_INT	SPI2	SPI2 interrupt
33	17	SPI3_INT	SPI3	SPI3 interrupt
34	18	I2C0_INT	I <sup>2</sup> C0	I <sup>2</sup> C0 interrupt
35	19	I2C1_INT	I <sup>2</sup> C1	I <sup>2</sup> C1 interrupt
36	20	Reserved	Reserved	Reserved
37	21	Reserved	Reserved	Reserved
38	22	Reserved	Reserved	Reserved
39	23	USB_INT	USBD	USB 2.0 FS Device interrupt
40	24	PS2_INT	PS/2	PS/2 interrupt
41	25	ACMP_INT	ACMP	Analog Comparator-0 or Comaprator-1 interrupt
42	26	PDMA_INT	PDMA	PDMA interrupt
43	27	I2S_INT	I <sup>2</sup> S	I <sup>2</sup> S interrupt
44	28	PWRWU_INT	CLKC	Clock controller interrupt for chip wake-up from power down state
45	29	ADC_INT	ADC	ADC interrupt
46	30	Reserved	Reserved	Reserved
47	31	RTC_INT	RTC	Real time clock interrupt

Table 5-3 System Interrupt Map

### 5.2.7.2 Vector Table

When any interrupts is accepted, the processor will automatically fetch the starting address of the interrupt service routine (ISR) from a vector table in memory. For ARMv6-M, the vector table base address is fixed at 0x00000000. The vector table contains the initialization value for the stack pointer on reset, and the entry point addresses for all exception handlers. The vector number on previous page defines the order of entries in the vector table associated with exception handler entry as illustrated in previous section.

Vector Table Word Offset	Description
0	SP_main – The Main stack pointer
Vector Number	Exception Entry Pointer using that Vector Number

Table 5-4 Vector Table Format

### 5.2.7.3 Operation Description

NVIC interrupts can be enabled and disabled by writing to their corresponding Interrupt Set-Enable or Interrupt Clear-Enable register bit-field. The registers use a write-1-to-enable and write-1-to-clear policy, both registers reading back the current enabled state of the corresponding interrupts. When an interrupt is disabled, interrupt assertion will cause the interrupt to become Pending, however, the interrupt will not activate. If an interrupt is Active when it is disabled, it remains in its Active state until cleared by reset or an exception return. Clearing the enable bit prevents new activations of the associated interrupt.

NVIC interrupts can be pended/un-pended using a complementary pair of registers to those used to enable/disable the interrupts, named the Set-Pending Register and Clear-Pending Register respectively. The registers use a write-1-to-enable and write-1-to-clear policy, both registers reading back the current pended state of the corresponding interrupts. The Clear-Pending Register has no effect on the execution status of an Active interrupt.

NVIC interrupts are prioritized by updating an 8-bit field within a 32-bit register (each register supporting four interrupts).

The general registers associated with the NVIC are all accessible from a block of memory in the System Control Space and will be described in next section.





## 5.2.7.4 NVIC Control Registers

R: read only, W: write only, R/W: both read and write

Register	Offset	R/W	Description	Reset Value
<b>SCS_BA = 0xE000_E000</b>				
<b>NVIC_ISER</b>	SCS_BA+0x100	R/W	IRQ0 ~ IRQ31 Set-Enable Control Register	0x0000_0000
<b>NVIC_ICER</b>	SCS_BA+0x180	R/W	IRQ0 ~ IRQ31 Clear-Enable Control Register	0x0000_0000
<b>NVIC_ISPR</b>	SCS_BA+0x200	R/W	IRQ0 ~ IRQ31 Set-Pending Control Register	0x0000_0000
<b>NVIC_ICPR</b>	SCS_BA+0x280	R/W	IRQ0 ~ IRQ31 Clear-Pending Control Register	0x0000_0000
<b>NVIC_IPR0</b>	SCS_BA+0x400	R/W	IRQ0 ~ IRQ3 Priority Control Register	0x0000_0000
<b>NVIC_IPR1</b>	SCS_BA+0x404	R/W	IRQ4 ~ IRQ7 Priority Control Register	0x0000_0000
<b>NVIC_IPR2</b>	SCS_BA+0x408	R/W	IRQ8 ~ IRQ11 Priority Control Register	0x0000_0000
<b>NVIC_IPR3</b>	SCS_BA+0x40C	R/W	IRQ12 ~ IRQ15 Priority Control Register	0x0000_0000
<b>NVIC_IPR4</b>	SCS_BA+0x410	R/W	IRQ16 ~ IRQ19 Priority Control Register	0x0000_0000
<b>NVIC_IPR5</b>	SCS_BA+0x414	R/W	IRQ20 ~ IRQ23 Priority Control Register	0x0000_0000
<b>NVIC_IPR6</b>	SCS_BA+0x418	R/W	IRQ24 ~ IRQ27 Priority Control Register	0x0000_0000
<b>NVIC_IPR7</b>	SCS_BA+0x41C	R/W	IRQ28 ~ IRQ31 Priority Control Register	0x0000_0000



## IRQ0 ~ IRQ31 Set-Enable Control Register (NVIC\_ISER)

Register	Offset	R/W	Description	Reset Value
NVIC_ISER	SCS_BA+0x100	R/W	IRQ0 ~ IRQ31 Set-Enable Control Register	0x0000_0000

31	30	29	28	27	26	25	24
SETENA[31:24]							
23	22	21	20	19	18	17	16
SETENA [23:16]							
15	14	13	12	11	10	9	8
SETENA [15:8]							
7	6	5	4	3	2	1	0
SETENA[7:0]							

Bits	Descriptions	
[31:0]	<b>SETENA</b>	Enable one or more interrupts within a group of 32. Each bit represents an interrupt number from IRQ0 ~ IRQ31 (Vector number from 16 ~ 47). Writing 1 will enable the associated interrupt. Writing 0 has no effect. The register reads back with the current enable state.



## IRQ0 ~ IRQ31 Clear-Enable Control Register (NVIC\_ICER)

Register	Offset	R/W	Description	Reset Value
NVIC_ICER	SCS_BA+0x180	R/W	IRQ0 ~ IRQ31 Clear-Enable Control Register	0x0000_0000

31	30	29	28	27	26	25	24
CLRENA[31:24]							
23	22	21	20	19	18	17	16
CLRENA [23:16]							
15	14	13	12	11	10	9	8
CLRENA [15:8]							
7	6	5	4	3	2	1	0
CLRENA[7:0]							

Bits	Descriptions	
[31:0]	<b>CLRENA</b>	<p>Disable one or more interrupts within a group of 32. Each bit represents an interrupt number from IRQ0 ~ IRQ31 (Vector number from 16 ~ 47).</p> <p>Writing 1 will disable the associated interrupt.</p> <p>Writing 0 has no effect.</p> <p>The register reads back with the current enable state.</p>



## IRQ0 ~ IRQ31 Set-Pending Control Register (NVIC ISPR)

Register	Offset	R/W	Description	Reset Value
NVIC_ISPR	SCS_BA+0x200	R/W	IRQ0 ~ IRQ31 Set-Pending Control Register	0x0000_0000

31	30	29	28	27	26	25	24
SETPEND[31:24]							
23	22	21	20	19	18	17	16
SETPEND [23:16]							
15	14	13	12	11	10	9	8
SETPEND [15:8]							
7	6	5	4	3	2	1	0
SETPEND [7:0]							

Bits	Descriptions
[31:0]	<p><b>SETPEND</b></p> <p>Writing 1 to a bit to set pending state of the associated interrupt under software control. Each bit represents an interrupt number from IRQ0 ~ IRQ31 (Vector number from 16 ~ 47).</p> <p>Writing 0 has no effect.</p> <p>The register reads back with the current pending state.</p>



## IRQ0 ~ IRQ31 Clear-Pending Control Register (NVIC\_ICPR)

Register	Offset	R/W	Description	Reset Value
NVIC_ICPR	SCS_BA+0x280	R/W	IRQ0 ~ IRQ31 Clear-Pending Control Register	0x0000_0000

31	30	29	28	27	26	25	24
CLRPEND [31:24]							
23	22	21	20	19	18	17	16
CLRPEND [23:16]							
15	14	13	12	11	10	9	8
CLRPEND [15:8]							
7	6	5	4	3	2	1	0
CLRPEND [7:0]							

Bits	Descriptions	
[31:0]	<b>CLRPEND</b>	<p>Writing 1 to a bit to remove the pending state of associated interrupt under software control. Each bit represents an interrupt number from IRQ0 ~ IRQ31 (Vector number from 16 ~ 47).</p> <p>Writing 0 has no effect.</p> <p>The register reads back with the current pending state.</p>



## IRQ0 ~ IRQ3 Interrupt Priority Register (NVIC IPR0)

Register	Offset	R/W	Description	Reset Value
NVIC_IPR0	SCS_BA+0x400	R/W	IRQ0 ~ IRQ3 Interrupt Priority Control Register	0x0000_0000

31	30	29	28	27	26	25	24
PRI_3		Reserved					
23	22	21	20	19	18	17	16
PRI_2		Reserved					
15	14	13	12	11	10	9	8
PRI_1		Reserved					
7	6	5	4	3	2	1	0
PRI_0		Reserved					

Bits	Descriptions	
[31:30]	PRI_3	<b>Priority of IRQ3</b> "0" denotes the highest priority and "3" denotes lowest priority
[29:24]	Reserved	Reserved
[23:22]	PRI_2	<b>Priority of IRQ2</b> "0" denotes the highest priority and "3" denotes lowest priority
[21:16]	Reserved	Reserved
[15:14]	PRI_1	<b>Priority of IRQ1</b> "0" denotes the highest priority and "3" denotes lowest priority
[13:8]	Reserved	Reserved
[7:6]	PRI_0	<b>Priority of IRQ0</b> "0" denotes the highest priority and "3" denotes lowest priority
[5:0]	Reserved	Reserved



## IRQ4 ~ IRQ7 Interrupt Priority Register (NVIC IPR1)

Register	Offset	R/W	Description	Reset Value
NVIC_IPR1	SCS_BA+0x404	R/W	IRQ4 ~ IRQ7 Interrupt Priority Control Register	0x0000_0000

31	30	29	28	27	26	25	24
PRI_7		Reserved					
23	22	21	20	19	18	17	16
PRI_6		Reserved					
15	14	13	12	11	10	9	8
PRI_5		Reserved					
7	6	5	4	3	2	1	0
PRI_4		Reserved					

Bits	Descriptions	
[31:30]	PRI_7	<b>Priority of IRQ7</b> "0" denotes the highest priority and "3" denotes lowest priority
[29:24]	Reserved	Reserved
[23:22]	PRI_6	<b>Priority of IRQ6</b> "0" denotes the highest priority and "3" denotes lowest priority
[21:16]	Reserved	Reserved
[15:14]	PRI_5	<b>Priority of IRQ5</b> "0" denotes the highest priority and "3" denotes lowest priority
[13:8]	Reserved	Reserved
[7:6]	PRI_4	<b>Priority of IRQ4</b> "0" denotes the highest priority and "3" denotes lowest priority
[5:0]	Reserved	Reserved



## IRQ8 ~ IRQ11 Interrupt Priority Register (NVIC IPR2)

Register	Offset	R/W	Description	Reset Value
NVIC_IPR2	SCS_BA+0x408	R/W	IRQ8 ~ IRQ11 Interrupt Priority Control Register	0x0000_0000

31	30	29	28	27	26	25	24
PRI_11		Reserved					
23	22	21	20	19	18	17	16
PRI_10		Reserved					
15	14	13	12	11	10	9	8
PRI_9		Reserved					
7	6	5	4	3	2	1	0
PRI_8		Reserved					

Bits	Descriptions	
[31:30]	PRI_11	<b>Priority of IRQ11</b> "0" denotes the highest priority and "3" denotes lowest priority
[29:24]	Reserved	Reserved
[23:22]	PRI_10	<b>Priority of IRQ10</b> "0" denotes the highest priority and "3" denotes lowest priority
[21:16]	Reserved	Reserved
[15:14]	PRI_9	<b>Priority of IRQ9</b> "0" denotes the highest priority and "3" denotes lowest priority
[13:8]	Reserved	Reserved
[7:6]	PRI_8	<b>Priority of IRQ8</b> "0" denotes the highest priority and "3" denotes lowest priority
[5:0]	Reserved	Reserved





## IRQ12 ~ IRQ15 Interrupt Priority Register (NVIC IPR3)

Register	Offset	R/W	Description	Reset Value
NVIC_IPR3	SCS_BA+0x40C	R/W	IRQ12 ~ IRQ15 Interrupt Priority Control Register	0x0000_0000

31	30	29	28	27	26	25	24
PRI_15		Reserved					
23	22	21	20	19	18	17	16
PRI_14		Reserved					
15	14	13	12	11	10	9	8
PRI_13		Reserved					
7	6	5	4	3	2	1	0
PRI_12		Reserved					

Bits	Descriptions	
[31:30]	PRI_15	<b>Priority of IRQ15</b> "0" denotes the highest priority and "3" denotes lowest priority
[29:24]	Reserved	Reserved
[23:22]	PRI_14	<b>Priority of IRQ14</b> "0" denotes the highest priority and "3" denotes lowest priority
[21:16]	Reserved	Reserved
[15:14]	PRI_13	<b>Priority of IRQ13</b> "0" denotes the highest priority and "3" denotes lowest priority
[13:8]	Reserved	Reserved
[7:6]	PRI_12	<b>Priority of IRQ12</b> "0" denotes the highest priority and "3" denotes lowest priority
[5:0]	Reserved	Reserved



## IRQ16 ~ IRQ19 Interrupt Priority Register (NVIC IPR4)

Register	Offset	R/W	Description	Reset Value
NVIC_IPR4	SCS_BA+0x410	R/W	IRQ16 ~ IRQ19 Interrupt Priority Control Register	0x0000_0000

31	30	29	28	27	26	25	24
PRI_19		Reserved					
23	22	21	20	19	18	17	16
PRI_18		Reserved					
15	14	13	12	11	10	9	8
PRI_17		Reserved					
7	6	5	4	3	2	1	0
PRI_16		Reserved					

Bits	Descriptions	
[31:30]	PRI_19	<b>Priority of IRQ19</b> "0" denotes the highest priority and "3" denotes lowest priority
[29:24]	Reserved	Reserved
[23:22]	PRI_18	<b>Priority of IRQ18</b> "0" denotes the highest priority and "3" denotes lowest priority
[21:16]	Reserved	Reserved
[15:14]	PRI_17	<b>Priority of IRQ17</b> "0" denotes the highest priority and "3" denotes lowest priority
[13:8]	Reserved	Reserved
[7:6]	PRI_16	<b>Priority of IRQ16</b> "0" denotes the highest priority and "3" denotes lowest priority
[5:0]	Reserved	Reserved



## IRQ20 ~ IRQ23 Interrupt Priority Register (NVIC IPR5)

Register	Offset	R/W	Description	Reset Value
NVIC_IPR5	SCS_BA+0x414	R/W	IRQ20 ~ IRQ23 Interrupt Priority Control Register	0x0000_0000

31	30	29	28	27	26	25	24
PRI_23		Reserved					
23	22	21	20	19	18	17	16
PRI_22		Reserved					
15	14	13	12	11	10	9	8
PRI_21		Reserved					
7	6	5	4	3	2	1	0
PRI_20		Reserved					

Bits	Descriptions	
[31:30]	PRI_23	<b>Priority of IRQ23</b> "0" denotes the highest priority and "3" denotes lowest priority
[29:24]	Reserved	Reserved
[23:22]	PRI_22	<b>Priority of IRQ22</b> "0" denotes the highest priority and "3" denotes lowest priority
[21:16]	Reserved	Reserved
[15:14]	PRI_21	<b>Priority of IRQ21</b> "0" denotes the highest priority and "3" denotes lowest priority
[13:8]	Reserved	Reserved
[7:6]	PRI_20	<b>Priority of IRQ20</b> "0" denotes the highest priority and "3" denotes lowest priority
[5:0]	Reserved	Reserved



## IRQ24 ~ IRQ27 Interrupt Priority Register (NVIC IPR6)

Register	Offset	R/W	Description	Reset Value
NVIC_IPR6	SCS_BA+0x418	R/W	IRQ24 ~ IRQ27 Interrupt Priority Control Register	0x0000_0000

31	30	29	28	27	26	25	24
PRI_27		Reserved					
23	22	21	20	19	18	17	16
PRI_26		Reserved					
15	14	13	12	11	10	9	8
PRI_25		Reserved					
7	6	5	4	3	2	1	0
PRI_24		Reserved					

Bits	Descriptions	
[31:30]	PRI_27	<b>Priority of IRQ27</b> "0" denotes the highest priority and "3" denotes lowest priority
[29:24]	Reserved	Reserved
[23:22]	PRI_26	<b>Priority of IRQ26</b> "0" denotes the highest priority and "3" denotes lowest priority
[21:16]	Reserved	Reserved
[15:14]	PRI_25	<b>Priority of IRQ25</b> "0" denotes the highest priority and "3" denotes lowest priority
[13:8]	Reserved	Reserved
[7:6]	PRI_24	<b>Priority of IRQ24</b> "0" denotes the highest priority and "3" denotes lowest priority
[5:0]	Reserved	Reserved



## IRQ28 ~ IRQ31 Interrupt Priority Register (NVIC IPR7)

Register	Offset	R/W	Description	Reset Value
NVIC_IPR7	SCS_BA+0x41C	R/W	IRQ28 ~ IRQ31 Interrupt Priority Control Register	0x0000_0000

31	30	29	28	27	26	25	24
PRI_31		Reserved					
23	22	21	20	19	18	17	16
PRI_30		Reserved					
15	14	13	12	11	10	9	8
PRI_29		Reserved					
7	6	5	4	3	2	1	0
PRI_28		Reserved					

Bits	Descriptions	
[31:30]	PRI_31	<b>Priority of IRQ31</b> "0" denotes the highest priority and "3" denotes lowest priority
[29:24]	Reserved	Reserved
[23:22]	PRI_30	<b>Priority of IRQ30</b> "0" denotes the highest priority and "3" denotes lowest priority
[21:16]	Reserved	Reserved
[15:14]	PRI_29	<b>Priority of IRQ29</b> "0" denotes the highest priority and "3" denotes lowest priority
[13:8]	Reserved	Reserved
[7:6]	PRI_28	<b>Priority of IRQ28</b> "0" denotes the highest priority and "3" denotes lowest priority
[5:0]	Reserved	Reserved



## 5.2.7.5 Interrupt Source Control Registers

Besides the interrupt control registers associated with the NVIC, NuMicro™ NUC100 Series also implement some specific control registers to facilitate the interrupt functions, including “interrupt source identification”, “NMI source selection” and “interrupt test mode”. They are described as below.

**R:** read only, **W:** write only, **R/W:** both read and write

Register	Offset	R/W	Description	Reset Value
<b>INT_BA = 0x5000_0300</b>				
<b>IRQ0_SRC</b>	INT_BA+0x00	R	IRQ0 (BOD) interrupt source identity	0xFFFF_XXXX
<b>IRQ1_SRC</b>	INT_BA+0x04	R	IRQ1 (WDT) interrupt source identity	0xFFFF_XXXX
<b>IRQ2_SRC</b>	INT_BA+0x08	R	IRQ2 (EINT0) interrupt source identity	0xFFFF_XXXX
<b>IRQ3_SRC</b>	INT_BA+0x0C	R	IRQ3 (EINT1) interrupt source identity	0xFFFF_XXXX
<b>IRQ4_SRC</b>	INT_BA+0x10	R	IRQ4 (GPA/B) interrupt source identity	0xFFFF_XXXX
<b>IRQ5_SRC</b>	INT_BA+0x14	R	IRQ5 (GPC/D/E) interrupt source identity	0xFFFF_XXXX
<b>IRQ6_SRC</b>	INT_BA+0x18	R	IRQ6 (PWMA) interrupt source identity	0xFFFF_XXXX
<b>IRQ7_SRC</b>	INT_BA+0x1C	R	IRQ7 (PWMB) interrupt source identity	0xFFFF_XXXX
<b>IRQ8_SRC</b>	INT_BA+0x20	R	IRQ8 (TMR0) interrupt source identity	0xFFFF_XXXX
<b>IRQ9_SRC</b>	INT_BA+0x24	R	IRQ9 (TMR1) interrupt source identity	0xFFFF_XXXX
<b>IRQ10_SRC</b>	INT_BA+0x28	R	IRQ10 (TMR2) interrupt source identity	0xFFFF_XXXX
<b>IRQ11_SRC</b>	INT_BA+0x2C	R	IRQ11 (TMR3) interrupt source identity	0xFFFF_XXXX
<b>IRQ12_SRC</b>	INT_BA+0x30	R	IRQ12 (URT0) interrupt source identity	0xFFFF_XXXX
<b>IRQ13_SRC</b>	INT_BA+0x34	R	IRQ13 (URT1) interrupt source identity	0xFFFF_XXXX
<b>IRQ14_SRC</b>	INT_BA+0x38	R	IRQ14 (SPI0) interrupt source identity	0xFFFF_XXXX
<b>IRQ15_SRC</b>	INT_BA+0x3C	R	IRQ15 (SPI1) interrupt source identity	0xFFFF_XXXX
<b>IRQ16_SRC</b>	INT_BA+0x40	R	IRQ16 (SPI2) interrupt source identity	0xFFFF_XXXX
<b>IRQ17_SRC</b>	INT_BA+0x44	R	IRQ17 (SPI3) interrupt source identity	0xFFFF_XXXX
<b>IRQ18_SRC</b>	INT_BA+0x48	R	IRQ18 (I <sup>2</sup> C0) interrupt source identity	0xFFFF_XXXX
<b>IRQ19_SRC</b>	INT_BA+0x4C	R	IRQ19 (I <sup>2</sup> C1) interrupt source identity	0xFFFF_XXXX
<b>IRQ20_SRC</b>	INT_BA+0x50	R	IRQ20 (Reserved) interrupt source identity	0xFFFF_XXXX
<b>IRQ21_SRC</b>	INT_BA+0x54	R	IRQ21 (Reserved) interrupt source identity	0xFFFF_XXXX



Register	Offset	R/W	Description	Reset Value
IRQ22_SRC	INT_BA+0x58	R	IRQ22 (Reserved) interrupt source identity	0XXXXX_XXXX
IRQ23_SRC	INT_BA+0x5C	R	IRQ23 (USB) interrupt source identity	0XXXXX_XXXX
IRQ24_SRC	INT_BA+0x60	R	IRQ24 (PS/2) interrupt source identity	0XXXXX_XXXX
IRQ25_SRC	INT_BA+0x64	R	IRQ25 (ACMP) interrupt source identity	0XXXXX_XXXX
IRQ26_SRC	INT_BA+0x68	R	IRQ26 (PDMA) interrupt source identity	0XXXXX_XXXX
IRQ27_SRC	INT_BA+0x6C	R	IRQ27 (I <sup>2</sup> S) interrupt source identity	0XXXXX_XXXX
IRQ28_SRC	INT_BA+0x70	R	IRQ28 (PWRWU) interrupt source identity	0XXXXX_XXXX
IRQ29_SRC	INT_BA+0x74	R	IRQ29 (ADC) interrupt source identity	0XXXXX_XXXX
IRQ30_SRC	INT_BA+0x78	R	IRQ30 (Reserved) interrupt source identity	0XXXXX_XXXX
IRQ31_SRC	INT_BA+0x7C	R	IRQ31 (RTC) interrupt source identity	0XXXXX_XXXX
NMI_SEL	INT_BA+0x80	R/W	NMI source interrupt select control register	0x0000_0000
MCU_IRQ	INT_BA+0x84	R/W	MCU IRQ Number identity register	0x0000_0000



## Interrupt Source Identity Register (IRQn\_SRC)

Register	Offset	R/W	Description	Reset Value
IRQn_SRC	INT_BA+0x00	R	IRQ0 (BOD) interrupt source identity	0xFFFF_FFFF
	INT_BA+0x7C		IRQ31 (RTC) interrupt source identity	

31	30	29	28	27	26	25	24
Reserved							
23	22	21	20	19	18	17	16
Reserved							
15	14	13	12	11	10	9	8
Reserved							
7	6	5	4	3	2	1	0
Reserved				INT_SRC[3]	INT_SRC[2:0]		

Bits	Address	INT-Num	Descriptions
[2:0]	INT_BA+0x00	0	Bit2: 0 Bit1: 0 Bit0: BOD_INT
[2:0]	INT_BA+0x04	1	Bit2: 0 Bit1: 0 Bit0: WDT_INT
[2:0]	INT_BA+0x08	2	Bit2: 0 Bit1: 0 Bit0: EINT0 – external interrupt 0 from PB.14
[2:0]	INT_BA+0x0C	3	Bit2: 0 Bit1: 0 Bit0: EINT1 – external interrupt 1 from PB.15
[2:0]	INT_BA+0x10	4	Bit2: 0 Bit1: GPB_INT Bit0: GPA_INT
[2:0]	INT_BA+0x14	5	Bit2: GPE_INT Bit1: GPD_INT Bit0: GPC_INT
[3:0]	INT_BA+0x18	6	Bit3: PWM3_INT Bit2: PWM2_INT





Bits	Address	INT-Num	Descriptions
			Bit1: PWM1_INT Bit0: PWM0_INT
[3:0]	INT_BA+0x1C	7	Bit3: PWM7_INT Bit2: PWM6_INT Bit1: PWM5_INT Bit0: PWM4_INT
[2:0]	INT_BA+0x20	8	Bit2: 0 Bit1: 0 Bit0: TMR0_INT
[2:0]	INT_BA+0x24	9	Bit2: 0 Bit1: 0 Bit0: TMR1_INT
[2:0]	INT_BA+0x28	10	Bit2: 0 Bit1: 0 Bit0: TMR2_INT
[2:0]	INT_BA+0x2C	11	Bit2: 0 Bit1: 0 Bit0: TMR3_INT
[2:0]	INT_BA+0x30	12	Bit2: 0 Bit1: URT2_INT Bit0: URT0_INT
[2:0]	INT_BA+0x34	13	Bit2: 0 Bit1: 0 Bit0: URT1_INT
[2:0]	INT_BA+0x38	14	Bit2: 0 Bit1: 0 Bit0: SPI0_INT
[2:0]	INT_BA+0x3C	15	Bit2: 0 Bit1: 0 Bit0: SPI1_INT
[2:0]	INT_BA+0x40	16	Bit2: 0 Bit1: 0 Bit0: SPI2_INT
[2:0]	INT_BA+0x44	17	Bit2: 0 Bit1: 0 Bit0: SPI3_INT
[2:0]	INT_BA+0x48	18	Bit2: 0



Bits	Address	INT-Num	Descriptions
			Bit1: 0 Bit0: I2C0_INT
[2:0]	INT_BA+0x4C	19	Bit2: 0 Bit1: 0 Bit0: I2C1_INT
[2:0]	INT_BA+0x50	20	Reserved
[2:0]	INT_BA+0x54	21	Reserved
[2:0]	INT_BA+0x58	22	Reserved
[2:0]	INT_BA+0x5C	23	Bit2: 0 Bit1: 0 Bit0: USB_INT
[2:0]	INT_BA+0x60	24	Bit2: 0 Bit1: 0 Bit0: PS2_INT
[2:0]	INT_BA+0x64	25	Bit2: 0 Bit1: 0 Bit0: ACMP_INT
[2:0]	INT_BA+0x68	26	Bit2: 0 Bit1: 0 Bit0: PDMA_INT
[2:0]	INT_BA+0x6C	27	Bit2: 0 Bit1: 0 Bit0: I2S_INT
[2:0]	INT_BA+0x70	28	Bit2: 0 Bit1: 0 Bit0: PWRWU_INT
[2:0]	INT_BA+0x74	29	Bit2: 0 Bit1: 0 Bit0: ADC_INT
[2:0]	INT_BA+0x78	30	Reserved
[2:0]	INT_BA+0x7C	31	Bit2: 0 Bit1: 0 Bit0: RTC_INT



**NMI Interrupt Source Select Control Register (NMI\_SEL)**

Register	Offset	R/W	Description	Reset Value
NMI_SEL	INT_BA+0x80	R/W	NMI source interrupt select control register	0x0000_0000

31	30	29	28	27	26	25	24
Reserved							
23	22	21	20	19	18	17	16
Reserved							
15	14	13	12	11	10	9	8
Reserved							
7	6	5	4	3	2	1	0
Reserved				NMI_SEL[4:0]			

Bits	Descriptions	
[31:5]	Reserved	Reserved
[4:0]	NMI_SEL	NMI interrupt source select The NMI interrupt to Cortex-M0 can be selected from one of the peripheral interrupt by setting NMI_SEL.



## MCU Interrupt Request Source Register (MCU\_IRQ)

Register	Offset	R/W	Description	Reset Value
MCU_IRQ	INT_BA+0x84	R/W	MCU Interrupt Request Source Register	0x0000_0000

31	30	29	28	27	26	25	24
MCU_IRQ[31:24]							
23	22	21	20	19	18	17	16
MCU_IRQ[23:16]							
15	14	13	12	11	10	9	8
MCU_IRQ[15:8]							
7	6	5	4	3	2	1	0
MCU_IRQ[7:0]							

Bits	Descriptions
[31:0]	<p><b>MCU IRQ Source Register</b></p> <p>The MCU_IRQ collects all the interrupts from the peripherals and generates the synchronous interrupt to Cortex-M0. There are two modes to generate interrupt to Cortex-M0, the normal mode and test mode.</p> <p>The MCU_IRQ collects all interrupts from each peripheral and synchronizes them then interrupts the Cortex-M0.</p> <p>When the MCU_IRQ[n] is 0: Set MCU_IRQ[n] 1 will generate an interrupt to Cortex_M0 NVIC[n].</p> <p>When the MCU_IRQ[n] is 1 (mean an interrupt is assert), set 1 to the MCU_IRQ[n] will clear the interrupt and set MCU_IRQ[n] 0 : no any effect</p>



### 5.2.8 System Control Register

Cortex-M0 status and operating mode control are managed by System Control Registers. Including CPUID, Cortex-M0 interrupt priority and Cortex-M0 power management can be controlled through these system control register

For more detailed information, please refer to the documents “ARM® Cortex™-M0 Technical Reference Manual” and “ARM® v6-M Architecture Reference Manual”.

R: read only, W: write only, R/W: both read and write

Register	Offset	R/W	Description	Reset Value
<b>SCS_BA = 0xE000_E000</b>				
<b>CPUID</b>	SCS_BA+0xD00	R	CPUID Register	0x410C_C200
<b>ICSR</b>	SCS_BA+0xD04	R/W	Interrupt Control and State Register	0x0000_0000
<b>AIRCR</b>	SCS_BA+0xD0C	R/W	Application Interrupt and Reset Control Register	0xFA05_0000
<b>SCR</b>	SCS_BA+0xD10	R/W	System Control Register	0x0000_0000
<b>SHPR2</b>	SCS_BA+0xD1C	R/W	System Handler Priority Register 2	0x0000_0000
<b>SHPR3</b>	SCS_BA+0xD20	R/W	System Handler Priority Register 3	0x0000_0000



## CPUID Register (CPUID)

Register	Offset	R/W	Description	Reset Value
CPUID	SCS_BA+0xD00	R	CPUID Register	0x410C_C200

31	30	29	28	27	26	25	24
<b>IMPLEMENTER[7:0]</b>							
23	22	21	20	19	18	17	16
Reserved				<b>PART[3:0]</b>			
15	14	13	12	11	10	9	8
<b>PARTNO[11:4]</b>							
7	6	5	4	3	2	1	0
<b>PARTNO[3:0]</b>				<b>REVISION[3:0]</b>			

Bits	Descriptions	
[31:24]	<b>IMPLEMENTER</b>	Implementer code assigned by ARM. ( ARM = 0x41)
[23:20]	<b>Reserved</b>	Reserved
[19:16]	<b>PART</b>	Reads as 0xC for ARMv6-M parts
[15:4]	<b>PARTNO</b>	Reads as 0xC20.
[3:0]	<b>REVISION</b>	Reads as 0x0



## Interrupt Control State Register (ICSR)

Register	Offset	R/W	Description	Reset Value
ICSR	SCS_BA+0xD04	R/W	Interrupt Control and State Register	0x0000_0000

31	30	29	28	27	26	25	24
NMIPENDSET	Reserved		PENDSVSET	PENDSVCLR	PENDSTSET	PENDSTCLR	Reserved
23	22	21	20	19	18	17	16
ISRPREEMPT	ISR_PENDING	Reserved				VECTPENDING[5:4]	
15	14	13	12	11	10	9	8
VECTPENDING[3:0]				Reserved			
7	6	5	4	3	2	1	0
Reserved		VECTACTIVE[5:0]					

Bits	Descriptions	
[31]	NMIPENDSET	<p>NMI set-pending bit</p> <p>Write:</p> <p>0 = no effect</p> <p>1 = changes NMI exception state to pending.</p> <p>Read:</p> <p>0 = NMI exception is not pending</p> <p>1 = NMI exception is pending.</p> <p>Because NMI is the highest-priority exception, normally the processor enters the NMI exception handler as soon as it detects a write of 1 to this bit. Entering the handler then clears this bit to 0. This means a read of this bit by the NMI exception handler returns 1 only if the NMI signal is reasserted while the processor is executing that handler.</p>
[30:29]	Reserved	Reserved
[28]	PENDSVSET	<p>PendSV set-pending bit.</p> <p>Write:</p> <p>0 = no effect</p> <p>1 = changes PendSV exception state to pending.</p> <p>Read:</p> <p>0 = PendSV exception is not pending</p> <p>1 = PendSV exception is pending.</p> <p>Writing 1 to this bit is the only way to set the PendSV exception state to pending.</p>
[27]	PENDSVCLR	<p>PendSV clear-pending bit.</p> <p>Write:</p>



Bits	Descriptions	
		0 = no effect 1 = removes the pending state from the PendSV exception.  This is a write only bit. When you want to clear PENDSV bit, you must “write 0 to PENDSVSET and write 1 to PENDSVCLR” at the same time.
[26]	<b>PENDSTSET</b>	SysTick exception set-pending bit.  Write: 0 = no effect 1 = changes SysTick exception state to pending.  Read: 0 = SysTick exception is not pending 1 = SysTick exception is pending.
[25]	<b>PENDSTCLR</b>	SysTick exception clear-pending bit.  Write: 0 = no effect 1 = removes the pending state from the SysTick exception.  This is a write only bit. When you want to clear PENDST bit, you must “write 0 to PENDSTSET and write 1 to PENDSTCLR” at the same time.
[24]	<b>Reserved</b>	Reserved
[23]	<b>ISRPREEMPT</b>	If set, a pending exception will be serviced on exit from the debug halt state.  This is a read only bit.
[22]	<b>ISRPENDING</b>	Interrupt pending flag, excluding NMI and Faults: 0 = interrupt not pending 1 = interrupt pending.  This is a read only bit.
[21:18]	<b>Reserved</b>	Reserved
[17:12]	<b>VECTPENDING</b>	Indicates the exception number of the highest priority pending enabled exception: 0 = no pending exceptions Nonzero = the exception number of the highest priority pending enabled exception.
[11:6]	<b>Reserved</b>	Reserved
[5:0]	<b>VECTACTIVE</b>	Contains the active exception number 0 = Thread mode Nonzero = The exception number of the currently active exception.





## Application Interrupt and Reset Control Register (AIRCR)

Register	Offset	R/W	Description	Reset Value
AIRCR	SCS_BA+0xD0C	R/W	Application Interrupt and Reset Control Register	0xFA05_0000

31	30	29	28	27	26	25	24
VECTORKEY[15:8]							
23	22	21	20	19	18	17	16
VECTORKEY[7:0]							
15	14	13	12	11	10	9	8
Reserved							
7	6	5	4	3	2	1	0
Reserved					SYSRESETR EQ	VECTCLKAC TIVE	Reserved

Bits	Descriptions	
[31:16]	<b>VECTORKEY</b>	When write this register, this field should be 0x05FA, otherwise the write action will be unpredictable.
[15:3]	<b>Reserved</b>	Reserved
[2]	<b>SYSRESETR EQ</b>	Writing this bit 1 will cause a reset signal to be asserted to the chip to indicate a reset is requested. The bit is a write only bit and self-clears as part of the reset sequence.
[1]	<b>VECTCLRACTIVE</b>	Set this bit to 1 will clear all active state information for fixed and configurable exceptions. The bit is a write only bit and can only be written when the core is halted. Note: It is the debugger's responsibility to re-initialize the stack.
[0]	<b>Reserved</b>	Reserved



## System Control Register (SCR)

Register	Offset	R/W	Description	Reset Value
SCR	SCS_BA+0xD10	R/W	System Control Register	0x0000_0000

31	30	29	28	27	26	25	24
Reserved							
23	22	21	20	19	18	17	16
Reserved							
15	14	13	12	11	10	9	8
Reserved							
7	6	5	4	3	2	1	0
Reserved			SEVONPEND	Reserved	SLEEPDEEP	SLEEPONEXIT	Reserved

Bits	Descriptions
[31:5]	Reserved
[4]	<p><b>SEVONPEND</b></p> <p>Send Event on Pending bit:                      0 = only enabled interrupts or events can wakeup the processor, disabled interrupts are excluded                      1 = enabled events and all interrupts, including disabled interrupts, can wakeup the processor.</p> <p>When an event or interrupt enters pending state, the event signal wakes up the processor from WFE. If the processor is not waiting for an event, the event is registered and affects the next WFE.</p> <p>The processor also wakes up on execution of an SEV instruction or an external event.</p>
[3]	Reserved
[2]	<p><b>SLEEPDEEP</b></p> <p>Controls whether the processor uses sleep or deep sleep as its low power mode:                      0 = sleep                      1 = deep sleep</p>
[1]	<p><b>SLEEPONEXIT</b></p> <p>Indicates sleep-on-exit when returning from Handler mode to Thread mode:                      0 = do not sleep when returning to Thread mode.                      1 = enter sleep, or deep sleep, on return from an ISR to Thread mode.</p> <p>Setting this bit to 1 enables an interrupt driven application to avoid returning to an empty main application.</p>
[0]	Reserved



## System Handler Priority Register 2 (SHPR2)

Register	Offset	R/W	Description	Reset Value
SHPR2	SCS_BA+0xD1C	R/W	System Handler Priority Register 2	0x0000_0000

31	30	29	28	27	26	25	24
PRI_11		Reserved					
23	22	21	20	19	18	17	16
Reserved							
15	14	13	12	11	10	9	8
Reserved							
7	6	5	4	3	2	1	0
Reserved							

Bits	Descriptions	
[31:30]	PRI_11	Priority of system handler 11 – SVCall “0” denotes the highest priority and “3” denotes lowest priority
[29:0]	Reserved	Reserved



## System Handler Priority Register 3 (SHPR3)

Register	Offset	R/W	Description	Reset Value
SHPR3	SCS_BA+0xD20	R/W	System Handler Priority Register 3	0x0000_0000

31	30	29	28	27	26	25	24
PRI_15		Reserved					
23	22	21	20	19	18	17	16
PRI_14		Reserved					
15	14	13	12	11	10	9	8
Reserved							
7	6	5	4	3	2	1	0
Reserved							

Bits	Descriptions	
[31:30]	PRI_15	Priority of system handler 15 – SysTick “0” denotes the highest priority and “3” denotes lowest priority
[29:24]	Reserved	Reserved
[23:22]	PRI_14	Priority of system handler 14 – PendSV “0” denotes the highest priority and “3” denotes lowest priority
[21:0]	Reserved	Reserved



## 5.3 Clock Controller

### 5.3.1 Overview

The clock controller generates the clocks for the whole chip, including system clocks and all peripheral clocks. The clock controller also implements the power control function with the individually clock ON/OFF control, clock source selection and a clock divider. The chip will not enter power down mode until CPU sets the power down enable bit (PWR\_DOWN\_EN) and Cortex-M0 core executes the WFI instruction. After that, chip enter power down mode and wait for wake-up interrupt source triggered to leave power down mode. In the power down mode, the clock controller turns off the external 4~24 MHz high speed crystal and internal 22.1184 MHz high speed oscillator to reduce the overall system power consumption.

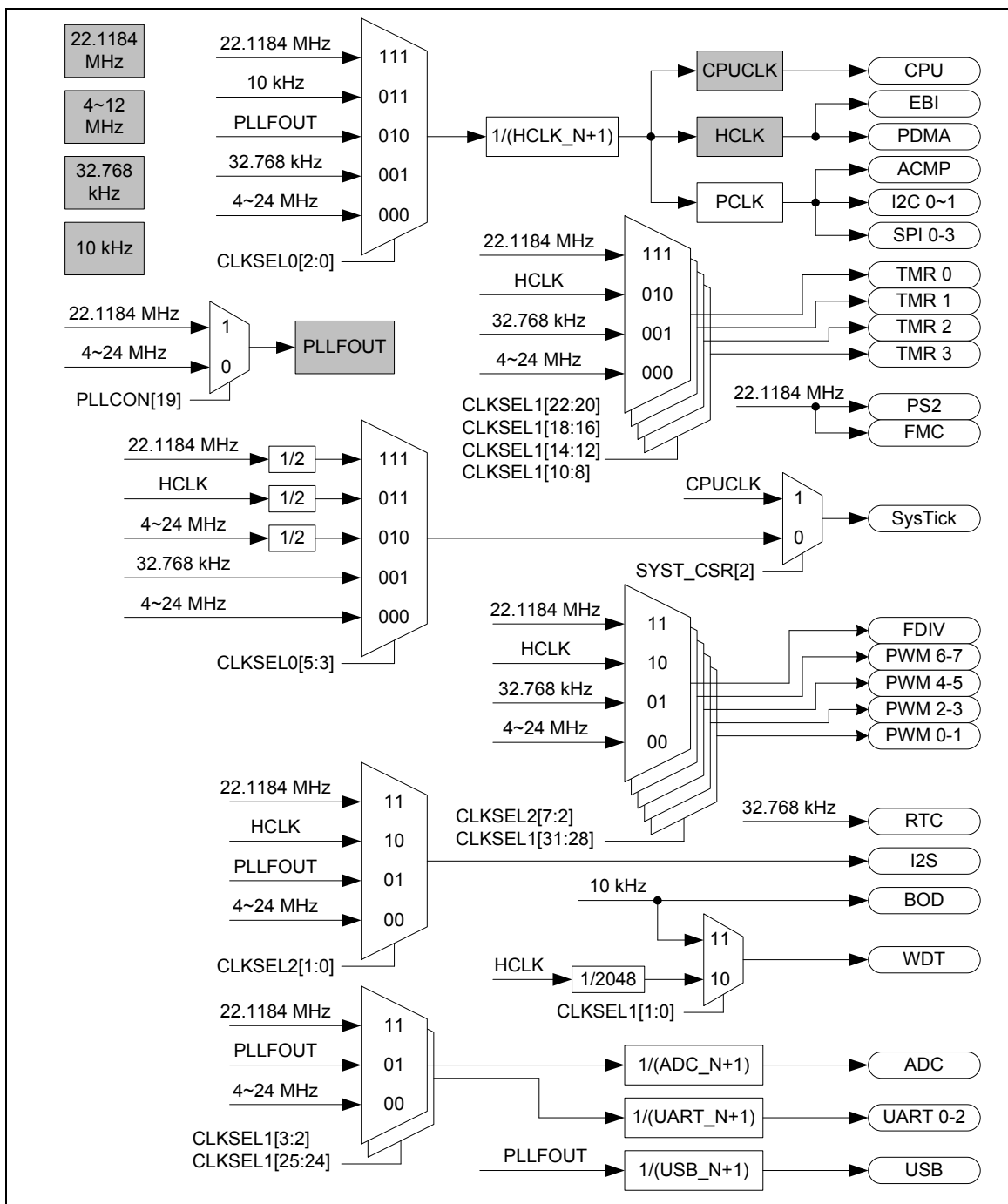

Figure 5-4 Clock generator global view diagram

## 5.3.2 Clock Generator

The clock generator consists of 5 clock sources which are listed below:

- One external 32.768 kHz low speed crystal
- One external 4~24 MHz high speed crystal
- One programmable PLL FOUT(PLL source consists of external 4~24 MHz high speed crystal and internal 22.1184 MHz high speed oscillator)
- One internal 22.1184 MHz high speed oscillator
- One internal 10 kHz low speed oscillator

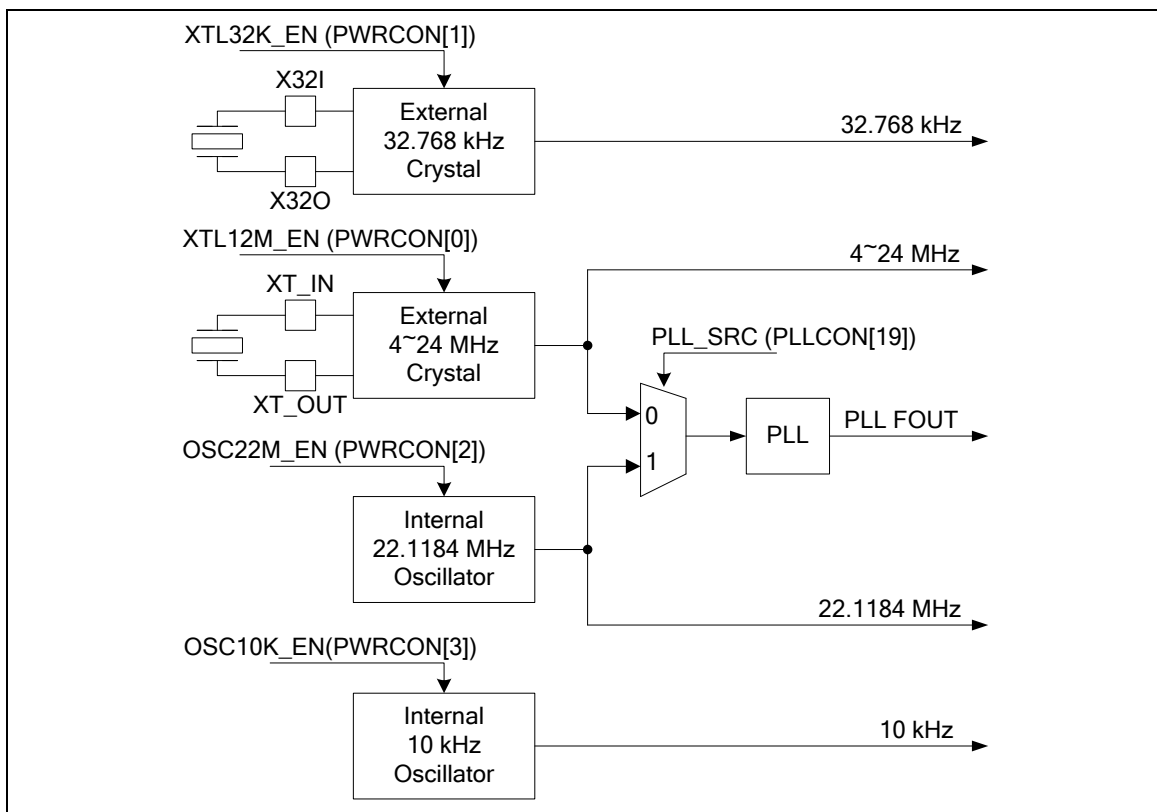

Figure 5-5 Clock generator block diagram

### 5.3.3 System Clock and SysTick Clock

The system clock has 5 clock sources which were generated from clock generator block. The clock source switch depends on the register HCLK\_S (CLKSEL0[2:0]). The block diagram is showed in Figure 5-6.

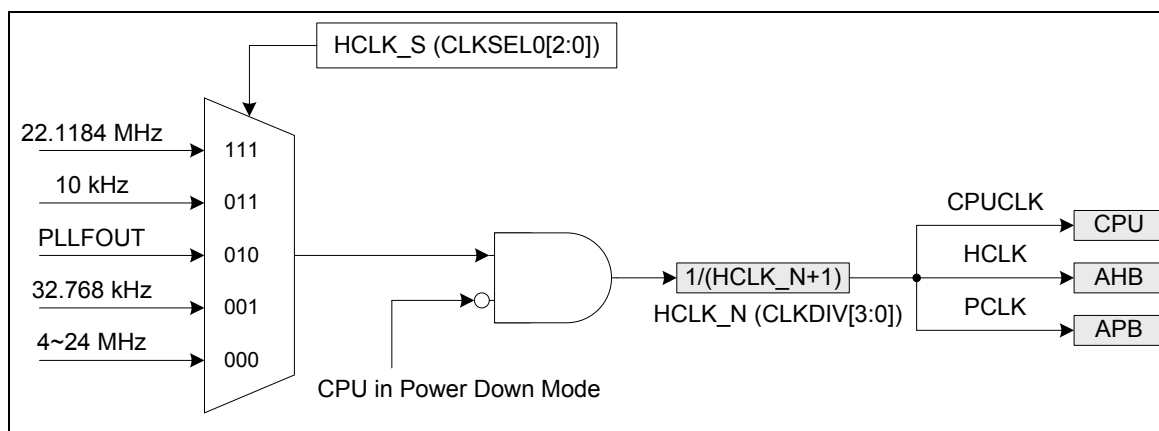

Figure 5-6 System Clock Block Diagram

The clock source of SysTick in Cortex-M0 core can use CPU clock or external clock (SYST\_CSR[2]). If using external clock, the SysTick clock (STCLK) has 5 clock sources. The clock source switch depends on the setting of the register STCLK\_S (CLKSEL0[5:3]). The block diagram is showed in Figure 5-7.

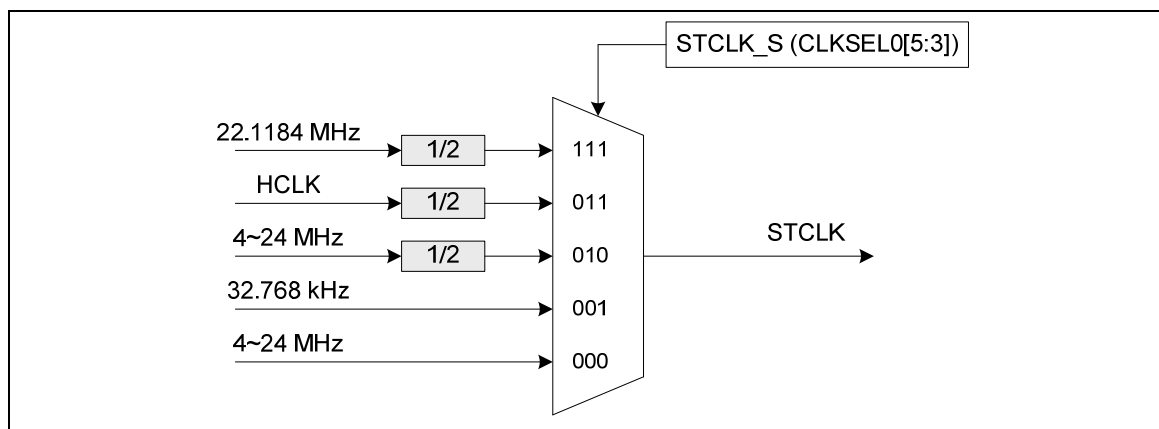

Figure 5-7 SysTick Clock Control Block Diagram



## 5.3.4 Peripherals Clock

The peripherals clock had different clock source switch setting which depends on the different peripheral. Please refer the CLKSEL1 and CLKSEL2 register description in 5.3.7.

## 5.3.5 Power Down Mode Clock

When chip enters into power down mode, system clocks, some clock sources, and some peripheral clocks will be disabled. Some clock sources and peripherals clock are still active in power down mode.

For these clocks which still keep active list below:

- Clock Generator
  - ◆ Internal 10 kHz low speed oscillator clock
  - ◆ External 32.768 kHz low speed crystal clock
- Peripherals Clock (When WDT adopt internal 10 kHz low speed oscillator as clock source and RTC adopt external 32.768 kHz low speed crystal as clock source)

### 5.3.6 Frequency Divider Output

This device is equipped a power-of-2 frequency divider which is composed by 16 chained divide-by-2 shift registers. One of the 16 shift register outputs selected by a sixteen to one multiplexer is reflected to CLKO function pin. Therefore there are 16 options of power-of-2 divided clocks with the frequency from  $F_{in}/2^1$  to  $F_{in}/2^{16}$  where  $F_{in}$  is input clock frequency to the clock divider.

The output formula is  $F_{out} = F_{in}/2^{(N+1)}$ , where  $F_{in}$  is the input clock frequency,  $F_{out}$  is the clock divider output frequency and N is the 4-bit value in FSEL (FRQDIV[3:0]).

When write 1 to DIVIDER\_EN (FRQDIV[4]), the chained counter starts to count. When write 0 to DIVIDER\_EN (FRQDIV[4]), the chained counter continuously runs till divided clock reaches low state and stay in low state.

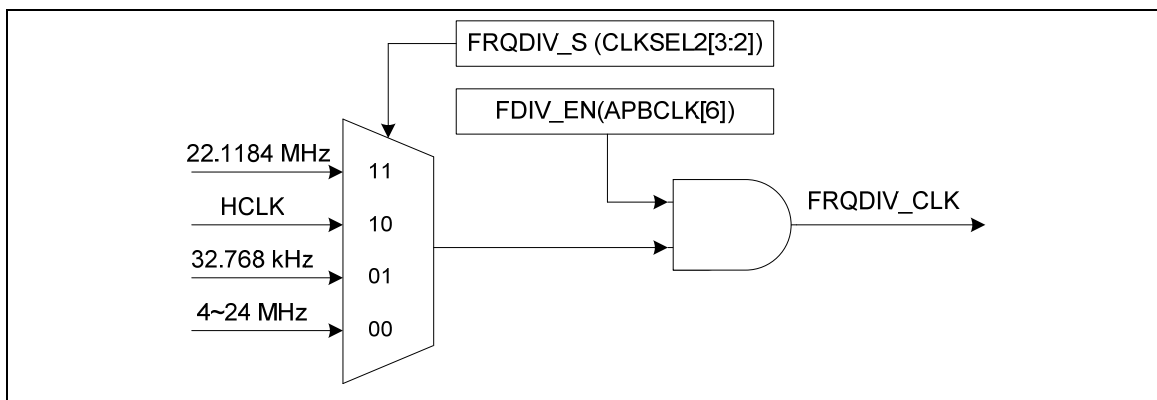

Figure 5-8 Clock Source of Frequency Divider

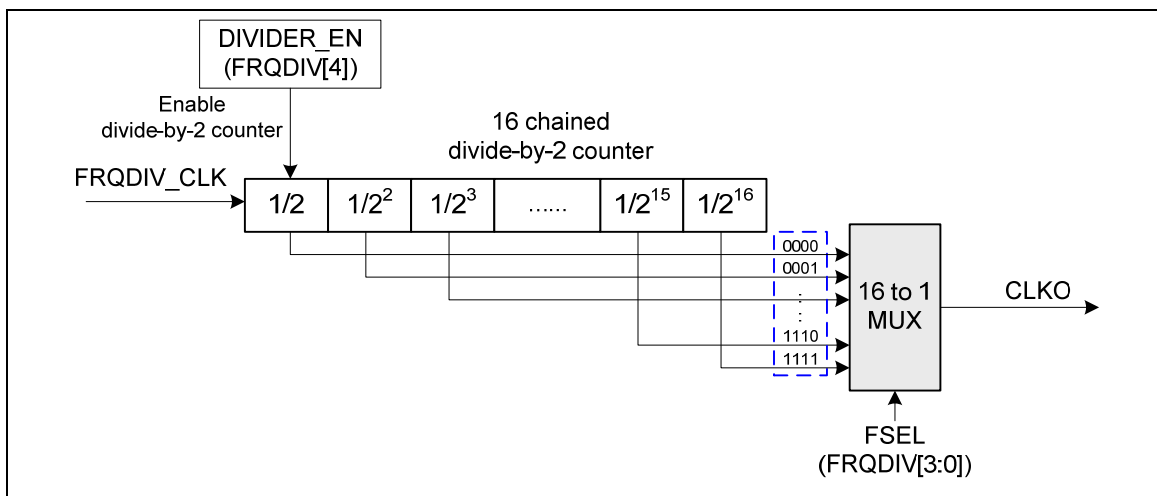

Figure 5-9 Block Diagram of Frequency Divider



## 5.3.7 Register Map

R: read only, W: write only, R/W: both read and write

Register	Offset	R/W	Description	Reset Value
<b>CLK_BA = 0x5000_0200</b>				
<b>PWRCON</b>	CLK_BA+0x00	R/W	System Power Down Control Register	0x0000_001X
<b>AHBCLK</b>	CLK_BA+0x04	R/W	AHB Devices Clock Enable Control Register	0x0000_000D
<b>APBCLK</b>	CLK_BA+0x08	R/W	APB Devices Clock Enable Control Register	0x0000_000X
<b>CLKSTATUS</b>	CLK_BA+0x0C	R/W	Clock status monitor Register (NuMicro™ NUC100/NUC120 Low Density Only)	0x0000_00XX
<b>CLKSEL0</b>	CLK_BA+0x10	R/W	Clock Source Select Control Register 0	0x0000_003X
<b>CLKSEL1</b>	CLK_BA+0x14	R/W	Clock Source Select Control Register 1	0xFFFF_FFFF
<b>CLKSEL2</b>	CLK_BA+0x1C	R/W	Clock Source Select Control Register 2	0x0000_00F0 <sup>[1]</sup> 0x0000_00FF
<b>CLKDIV</b>	CLK_BA+0x18	R/W	Clock Divider Number Register	0x0000_0000
<b>PLLCON</b>	CLK_BA+0x20	R/W	PLL Control Register	0x0005_C22E
<b>FRQDIV</b>	CLK_BA+0x24	R/W	Frequency Divider Control Register	0x0000_0000

Note: [1] default value is 0x0000\_00F0 in NuMicro™ NUC100/NUC120 Medium Density; default value is 0x0000\_00FF in NuMicro™ NUC100/NUC120 Low Density



5.3.8 Register Description

**Power Down Control Register (PWRCON)**

Except the BIT[6], all the other bits are protected, program these bits need to write “59h”, “16h”, “88h” to address 0x5000\_0100 to disable register protection. Reference the register REGWRPROT at address GCR\_BA+0x100

Register	Offset	R/W	Description	Reset Value
PWRCON	CLK_BA+0x00	R/W	System Power Down Control Register	0x0000_001X

31	30	29	28	27	26	25	24
Reserved							
23	22	21	20	19	18	17	16
Reserved							
15	14	13	12	11	10	9	8
Reserved							PD_WAIT_CPU
7	6	5	4	3	2	1	0
PWR_DOWN_EN	PD_WU_STS	PD_WU_INT_EN	PD_WU_DLY	OSC10K_EN	OSC22M_EN	XTL32K_EN	XTL12M_EN

Bits	Descriptions	
[31:9]	Reserved	Reserve
[8]	PD_WAIT_CPU	<p><b>This Bit Control the Power Down Entry Condition</b> (write-protection bit)</p> <p>1 = Chip enter power down mode when the both PD_WAIT_CPU and PWR_DOWN_EN bits are set to 1 and CPU run WFI instruction.</p> <p>0 = Chip entry power down mode when the PWR_DOWN_EN bit is set to 1</p>
[7]	PWR_DOWN_EN	<p><b>System Power Down Enable Bit</b> (write-protection bit)</p> <p>When this bit is set to 1, the chip power down mode is enabled and chip power down behavior will depends on the PD_WAIT_CPU bit</p> <p>(a) If the PD_WAIT_CPU is 0, then the chip enters power down mode immediately after the PWR_DOWN_EN bit set.</p> <p>(b) if the PD_WAIT_CPU is 1, then the chip keeps active till the CPU sleep mode is also active and then the chip enters power down mode</p> <p>When chip wakes up from power down mode, this bit is auto cleared. Users need to set this bit again for next power down.</p> <p>When in power down mode, external 4~24 MHz high speed crystal and the internal 22.1184 MHz high speed oscillator will be disabled in this mode, but the external 32.768 kHz low speed crystal and internal 10 kHz low speed oscillator are not controlled by power down mode.</p> <p>When in power down mode, the PLL and system clock are disabled, and ignored the clock source selection. The clocks of peripheral are not controlled by power down</p>



Bits	Descriptions
	<p>mode, if the peripheral clock source is from external 32.768 kHz low speed crystal or the internal 10 kHz low speed oscillator.</p> <p>1 = Chip enter the power down mode instant or wait CPU sleep command WFI 0 = Chip operating normally or chip in idle mode because of WFI command</p>
[6]	<p><b>PD_WU_STS</b></p> <p><b>Power Down Mode Wake-up Interrupt Status</b> Set by “power down wake-up event”, it indicates that resume from power down mode” The flag is set if the GPIO, USB, UART, WDT, ACMP, BOD or RTC wake-up occurred Write 1 to clear the bit to zero. Note: This bit is working only if PD_WU_INT_EN (PWRCON[5]) set to 1.</p>
[5]	<p><b>PD_WU_INT_EN</b></p> <p><b>Power Down Mode Wake-up Interrupt Enable</b> (write-protection bit) 0 = Disable 1 = Enable The interrupt will occur when both PD_WU_STS and PD_WU_INT_EN are high.</p>
[4]	<p><b>PD_WU_DLY</b></p> <p><b>Enable the Wake-up Delay Counter</b> (write-protection bit) When the chip wakes up from power down mode, the clock control will delay certain clock cycles to wait system clock stable. The delayed clock cycle is 4096 clock cycles when chip work at external 4~24 MHz high speed crystal, and 256 clock cycles when chip work at internal 22.1184 MHz high speed oscillator. 1 = Enable clock cycles delay 0 = Disable clock cycles delay</p>
[3]	<p><b>OSC10K_EN</b></p> <p><b>Internal 10 kHz Low Speed Oscillator Enable</b> (write-protection bit) 1 = Enable internal 10 kHz low speed oscillator 0 = Disable internal 10 kHz low speed oscillator</p>
[2]	<p><b>OSC22M_EN</b></p> <p><b>Internal 22.1184 MHz High Speed Oscillator Enable</b> (write-protection bit) 1 = Enable internal 22.1184 MHz high speed oscillator 0 = Disable internal 22.1184 MHz high speed oscillator</p>
[1]	<p><b>XTL32K_EN</b></p> <p><b>External 32.768 kHz Low Speed Crystal Enable</b> (write-protection bit) 1 = Enable external 32.768 kHz low speed crystal (Normal operation) 0 = Disable external 32.768 kHz low speed crystal</p>
[0]	<p><b>XTL12M_EN</b></p> <p><b>External 4~24 MHz High Speed Crystal Enable</b> (write-protection bit) The bit default value is set by flash controller user configuration register config0 [26:24]. When the default clock source is from external 4~24 MHz high speed crystal, this bit is set to 1 automatically 1 = Enable external 4~24 MHz high speed crystal 0 = Disable external 4~24 MHz high speed crystal</p>



Register/Instruction Mode	PWR_DOWN_EN	PD_WAIT_CPU	CPU run WFI instruction	Clock Disable
Normal operation	0	0	NO	All clocks are disabled by control register
Idle mode (CPU entry sleep mode)	0	0	YES	Only CPU clock is disabled
Power down mode	1	0	NO	Most clocks are disabled except 10 kHz/32.768 kHz, only RTC/WDT peripheral clock are still enabled.
Power down mode (CPU entry deep sleep mode)	1	1	YES	Most clocks are disabled except 10 kHz/32.768 kHz, only RTC/WDT peripheral clock are still enabled.

Table 5-5 Power Down Mode Control Table

When chip enter power down mode, user can wake-up chip by some interrupt sources. User should enable related interrupt sources and NVIC IRQ enable bits (NVIC\_ISER) before set PWR\_DOWN\_EN bit in PWRCON[7] to ensure chip can enter power down and be wake-up successfully.



## AHB Devices Clock Enable Control Register (AHBCLK)

These bits for this register are used to enable/disable clock for system clock PDMA clock and EBI clock.

Register	Offset	R/W	Description	Reset Value
AHBCLK	CLK_BA+0x04	R/W	AHB Devices Clock Enable Control Register	0x0000_000D

31	30	29	28	27	26	25	24
Reserved							
23	22	21	20	19	18	17	16
Reserved							
15	14	13	12	11	10	9	8
Reserved							
7	6	5	4	3	2	1	0
Reserved				EBI_EN	ISP_EN	PDMA_EN	Reserved

Bits	Descriptions	
[31:4]	Reserved	Reserved
[3]	EBI_EN	<b>EBI Controller Clock Enable Control</b> (NuMicro™ NUC100/NUC120 Low Density Only) 1 = Enable the EBI engine clock 0 = Disable the EBI engine clock
[2]	ISP_EN	<b>Flash ISP Controller Clock Enable Control</b> 1 = Enable the Flash ISP engine clock 0 = Disable the Flash ISP engine clock
[1]	PDMA_EN	<b>PDMA Controller Clock Enable Control</b> 1 = Enable the PDMA engine clock 0 = Disable the PDMA engine clock
[0]	Reserved	Reserved



## APB Devices Clock Enable Control Register (APBCLK)

These bits of this register are used to enable/disable clock for peripheral controller clocks.

Register	Offset	R/W	Description	Reset Value
APBCLK	CLK_BA+0x08	R/W	APB Devices Clock Enable Control Register	0x0000_000X

31	30	29	28	27	26	25	24
PS2_EN	ACMP_EN	I2S_EN	ADC_EN	USBD_EN	Reserved		
23	22	21	20	19	18	17	16
PWM67_EN	PWM45_EN	PWM23_EN	PWM01_EN	Reserved	UART2_EN	UART1_EN	UART0_EN
15	14	13	12	11	10	9	8
SPI3_EN	SPI2_EN	SPI1_EN	SPI0_EN	Reserved		I2C1_EN	I2C0_EN
7	6	5	4	3	2	1	0
Reserved	FDIV_EN	TMR3_EN	TMR2_EN	TMR1_EN	TMR0_EN	RTC_EN	WDT_EN

Bits	Descriptions	
[31]	PS2_EN	<b>PS/2 Clock Enable</b> 1 = Enable PS/2 clock 0 = Disable PS/2 clock
[30]	ACMP_EN	<b>Analog Comparator Clock Enable</b> 1 = Enable the Analog Comparator Clock 0 = Disable the Analog Comparator Clock
[29]	I2S_EN	<b>I<sup>2</sup>S Clock Enable</b> 1 = Enable I <sup>2</sup> S Clock 0 = Disable I <sup>2</sup> S Clock
[28]	ADC_EN	<b>Analog-Digital-Converter (ADC) Clock Enable</b> 1 = Enable ADC clock 0 = Disable ADC clock
[27]	USBD_EN	<b>USB 2.0 FS Device Controller Clock Enable</b> 1 = Enable USB clock 0 = Disable USB clock
[26:24]	Reserved	Reserved
[23]	PWM67_EN	<b>PWM_67 Clock Enable</b> (NuMicro™ NUC100/NUC120 Medium Density Only) 1 = Enable PWM67 clock 0 = Disable PWM67 clock
[22]	PWM45_EN	<b>PWM_45 Clock Enable</b> (NuMicro™ NUC100/NUC120 Medium Density Only)





Bits	Descriptions	
		1 = Enable PWM45 clock 0 = Disable PWM45 clock
[21]	<b>PWM23_EN</b>	<b>PWM_23 Clock Enable</b> 1 = Enable PWM23 clock 0 = Disable PWM23 clock
[20]	<b>PWM01_EN</b>	<b>PWM_01 Clock Enable</b> 1 = Enable PWM01 clock 0 = Disable PWM01 clock
[19]	<b>Reserved</b>	Reserved
[18]	<b>UART2_EN</b>	<b>UART2 Clock Enable</b> (NuMicro™ NUC100/NUC120 Medium Density Only) 1 = Enable UART2 clock 0 = Disable UART2 clock
[17]	<b>UART1_EN</b>	<b>UART1 Clock Enable</b> 1 = Enable UART1 clock 0 = Disable UART1 clock
[16]	<b>UART0_EN</b>	<b>UART0 Clock Enable</b> 1 = Enable UART0 clock 0 = Disable UART0 clock
[15]	<b>SPI3_EN</b>	<b>SPI3 Clock Enable</b> (NuMicro™ NUC100/NUC120 Medium Density Only) 1 = Enable SPI3 Clock 0 = Disable SPI3 Clock
[14]	<b>SPI2_EN</b>	<b>SPI2 Clock Enable</b> (NuMicro™ NUC100/NUC120 Medium Density Only) 1 = Enable SPI2 Clock 0 = Disable SPI2 Clock
[13]	<b>SPI1_EN</b>	<b>SPI1 Clock Enable</b> 1 = Enable SPI1 Clock 0 = Disable SPI1 Clock
[12]	<b>SPI0_EN</b>	<b>SPI0 Clock Enable</b> 1 = Enable SPI0 Clock 0 = Disable SPI0 Clock
[11:10]	<b>Reserved</b>	Reserved
[9]	<b>I2C1_EN</b>	<b>I<sup>2</sup>C1 Clock Enable</b> 1 = Enable I <sup>2</sup> C1 Clock 0 = Disable I <sup>2</sup> C1 Clock
[8]	<b>I2C0_EN</b>	<b>I<sup>2</sup>C0 Clock Enable</b> 1 = Enable I <sup>2</sup> C0 Clock



Bits	Descriptions	
		0 = Disable I <sup>2</sup> C0 Clock
[7]	<b>Reserved</b>	Reserved
[6]	<b>FDIV_EN</b>	<b>Frequency Divider Output Clock Enable</b> 1 = Enable FDIV Clock 0 = Disable FDIV Clock
[5]	<b>TMR3_EN</b>	<b>Timer3 Clock Enable</b> 1 = Enable Timer3 Clock 0 = Disable Timer3 Clock
[4]	<b>TMR2_EN</b>	<b>Timer2 Clock Enable</b> 1 = Enable Timer2 Clock 0 = Disable Timer2 Clock
[3]	<b>TMR1_EN</b>	<b>Timer1 Clock Enable</b> 1 = Enable Timer1 Clock 0 = Disable Timer1 Clock
[2]	<b>TMR0_EN</b>	<b>Timer0 Clock Enable</b> 1 = Enable Timer0 Clock 0 = Disable Timer0 Clock
[1]	<b>RTC_EN</b>	<b>Real-Time-Clock APB interface Clock Enable</b> This bit is used to control the RTC APB clock only, The RTC engine clock source is from the external 32.768 kHz low speed crystal. 1 = Enable RTC Clock 0 = Disable RTC Clock
[0]	<b>WDT_EN</b>	<b>Watchdog Timer Clock Enable (write-protection bit)</b> This bit is the protected bit. It means programming this needs to write "59h", "16h", "88h" to address 0x5000_0100 to disable register protection. Reference the register REGWRPROT at address GCR_BA+0x100. 1 = Enable Watchdog Timer Clock 0 = Disable Watchdog Timer Clock



## Clock status Register (CLKSTATUS)

These bits of this register are used to monitor if the chip clock source stable or not, and whether clock switch failed. (Only support in NuMicro™ NUC100/NUC120 Low Density)

Register	Offset	R/W	Description	Reset Value
CLKSTATUS	CLK_BA+0x0C	R/W	Clock status monitor Register	0x0000_00XX

31	30	29	28	27	26	25	24
Reserved							
23	22	21	20	19	18	17	16
Reserved							
15	14	13	12	11	10	9	8
Reserved							
7	6	5	4	3	2	1	0
CLK_SW_FAIL	Reserved		OSC22M_STB	OSC10K_STB	PLL_STB	XTL32K_STB	XTL12M_STB

Bits	Descriptions	
[31:8]	Reserved	Reserved
[7]	CLK_SW_FAIL	<p><b>Clock switching fail flag</b></p> <p>1 = Clock switching failure 0 = Clock switching success</p> <p>This bit is updated when software switches system clock source. If switch target clock is stable, this bit will be set to 0. If switch target clock is not stable, this bit will be set to 1.</p> <p>Write 1 to clear the bit to zero.</p> <p>Note: this bit only support in NuMicro™ NUC100/NUC120 Low Density</p>
[6:5]	Reserved	Reserved
[4]	OSC22M_STB	<p><b>Internal 22.1184 MHz High Speed oscillator clock source stable flag</b></p> <p>1 = Internal 22.1184 MHz high speed oscillator clock is stable 0 = Internal 22.1184 MHz high speed oscillator clock is not stable or disabled</p> <p>This is read only bit</p>
[3]	OSC10K_STB	<p><b>Internal 10 kHz Low Speed oscillator clock source stable flag</b></p> <p>1 = Internal 10 kHz low speed oscillator clock is stable 0 = Internal 10 kHz low speed oscillator clock is not stable or disabled</p> <p>This is read only bit</p>
[2]	PLL_STB	<p><b>Internal PLL clock source stable flag</b></p> <p>1 = Internal PLL clock is stable</p>



Bits	Descriptions	
		0 = Internal PLL clock is not stable or disabled This is read only bit
[1]	<b>XTL32K_STB</b>	<b>External 32.768 kHz Low Speed crystal clock source stable flag</b> 1 = External 32.768 kHz low speed crystal clock is stable 0 = External 32.768 kHz low speed crystal clock is not stable or disabled This is read only bit
[0]	<b>XTL12M_STB</b>	<b>External 4~24 MHz High Speed crystal clock source stable flag</b> 1 = External 4~24 MHz high speed crystal clock is stable 0 = External 4~24 MHz high speed crystal clock is not stable or disabled This is read only bit



**Clock Source Select Control Register 0 (CLKSEL0)**

Register	Offset	R/W	Description	Reset Value
CLKSEL0	CLK_BA+0x10	R/W	Clock Source Select Control Register 0	0x0000_003X

31	30	29	28	27	26	25	24
Reserved							
23	22	21	20	19	18	17	16
Reserved							
15	14	13	12	11	10	9	8
Reserved							
7	6	5	4	3	2	1	0
Reserved		STCLK_S			HCLK_S		

Bits	Descriptions	
[31:6]	Reserved	Reserved
[5:3]	STCLK_S	<p><b>Cortex_M0 SysTick clock source select</b> (write-protection bits)</p> <p>If SYST_CSR[2]=0, SysTick uses listed clock source below</p> <p>These bits are protected bit. It means programming this bit needs to write “59h”, “16h”, “88h” to address 0x5000_0100 to disable register protection. Reference the register REGWRPROT at address GCR_BA+0x100.</p> <p>000 = Clock source from external 4~24 MHz high speed crystal clock                      001 = Clock source from external 32.768 kHz low speed crystal clock                      010 = Clock source from external 4~24 MHz high speed crystal clock/2                      011 = Clock source from HCLK/2                      111 = Clock source from internal 22.1184 MHz high speed oscillator clock/2</p>
[2:0]	HCLK_S	<p><b>HCLK clock source select</b> (write-protection bits)</p> <ol style="list-style-type: none"> <li>Before clock switching, the related clock sources (both pre-select and new-select) must be turn on</li> <li>The 3-bit default value is reloaded from the value of CFOSC (Config0[26:24]) in user configuration register of Flash controller by any reset. Therefore the default value is either 000b or 111b.</li> <li>These bits are protected bit, It means programming this bit needs to write “59h”, “16h”, “88h” to address 0x5000_0100 to disable register protection. Reference the register REGWRPROT at address GCR_BA+0x100.</li> </ol> <p>000 = Clock source from external 4~24 MHz high speed crystal clock                      001 = Clock source from external 32.768 kHz low speed crystal clock                      010 = Clock source from PLL clock                      011 = Clock source from internal 10 kHz low speed oscillator clock                      111 = Clock source from internal 22.1184 MHz high speed oscillator clock</p>



## Clock Source Select Control Register 1(CLKSEL1)

Before clock switching, the related clock sources (pre-select and new-select) must be turned on.

Register	Offset	R/W	Description	Reset Value
CLKSEL1	CLK_BA+0x14	R/W	Clock Source Select Control Register 1	0xFFFF_FFFF

31	30	29	28	27	26	25	24
PWM23_S		PWM01_S		Reserved		UART_S	
23	22	21	20	19	18	17	16
Reserved	TMR3_S			Reserved	TMR2_S		
15	14	13	12	11	10	9	8
Reserved	TMR1_S			Reserved	TMR0_S		
7	6	5	4	3	2	1	0
Reserved				ADC_S		WDT_S	

Bits	Descriptions
[31:30]	<p><b>PWM23_S</b></p> <p><b>PWM2 and PWM3 clock source select</b>                      PWM2 and PWM3 uses the same Engine clock source, both of them use the same prescaler</p> <p>00 = Clock source from external 4~24 MHz high speed crystal clock                      01 = Clock source from external 32.768 kHz low speed crystal clock                      10 = Clock source from HCLK                      11 = Clock source from internal 22.1184 MHz high speed oscillator clock</p>
[29:28]	<p><b>PWM01_S</b></p> <p><b>PWM0 and PWM1 clock source select</b>                      PWM0 and PWM1 uses the same Engine clock source, both of them use the same prescaler</p> <p>00 = Clock source from external 4~24 MHz high speed crystal clock                      01 = Clock source from external 32.768 kHz low speed crystal clock                      10 = Clock source from HCLK                      11 = Clock source from internal 22.1184 MHz high speed oscillator clock</p>
[27:26]	Reserved
[25:24]	<p><b>UART_S</b></p> <p><b>UART clock source select</b>                      00 = Clock source from external 4~24 MHz high speed crystal clock                      01 = Clock source from PLL clock                      11 = Clock source from internal 22.1184 MHz high speed oscillator clock</p>
[23]	Reserved



Bits	Descriptions	
[22:20]	<b>TMR3_S</b>	<b>TIMER3 clock source select</b> 000 = Clock source from external 4~24 MHz high speed crystal clock 001 = Clock source from external 32.768 kHz low speed crystal clock 010 = Clock source from HCLK 111 = Clock source from internal 22.1184 MHz high speed oscillator clock
[19]	<b>Reserved</b>	Reserved
[18:16]	<b>TMR2_S</b>	<b>TIMER2 clock source select</b> 000 = Clock source from external 4~24 MHz high speed crystal clock 001 = Clock source from external 32.768 kHz low speed crystal clock 010 = Clock source from HCLK 111 = Clock source from internal 22.1184 MHz high speed oscillator clock
[15]	<b>Reserved</b>	Reserved
[14:12]	<b>TMR1_S</b>	<b>TIMER1 clock source select</b> 000 = Clock source from external 4~24 MHz high speed crystal clock 001 = Clock source from external 32.768 kHz low speed crystal clock 010 = Clock source from HCLK 111 = Clock source from internal 22.1184 MHz high speed oscillator clock
[11]	<b>Reserved</b>	Reserved
[10:8]	<b>TMR0_S</b>	<b>TIMER0 clock source select</b> 000 = Clock source from external 4~24 MHz high speed crystal clock 001 = Clock source from external 32.768 kHz low speed crystal clock 010 = Clock source from HCLK 111 = Clock source from internal 22.1184 MHz high speed oscillator clock
[7:4]	<b>Reserved</b>	Reserved
[3:2]	<b>ADC_S</b>	<b>ADC clock source select</b> 00 = Clock source from external 4~24 MHz high speed crystal clock 01 = Clock source from PLL clock 11 = Clock source from internal 22.1184 MHz high speed oscillator clock
[1:0]	<b>WDT_S</b>	<b>Watchdog Timer clock source select (write-protection bits)</b> These bits are protected bit, program this need to write "59h", "16h", "88h" to address 0x5000_0100 to disable register protection. Reference the register REGWRPROT at address GCR_BA+0x100. 10 = Clock source from HCLK/2048 clock 11 = Clock source from internal 10 kHz low speed oscillator clock



## Clock Source Select Control Register 2 (CLKSEL2)

Before clock switching, the related clock sources (pre-select and new-select) must be turned on.

Register	Offset	R/W	Description	Reset Value
CLKSEL2	CLK_BA+0x1C	R/W	Clock Source Select Control Register 2	0x0000_00F0 <sup>[1]</sup> 0x0000_00FF

Note: [1] default value is 0x0000\_00F0 in NuMicro™ NUC100/NUC120 Medium Density; default value is 0x0000\_00FF in NuMicro™ NUC100/NUC120 Low Density

31	30	29	28	27	26	25	24
Reserved							
23	22	21	20	19	18	17	16
Reserved							
15	14	13	12	11	10	9	8
Reserved							
7	6	5	4	3	2	1	0
PWM67_S		PWM45_S		FRQDIV_S		I2S_S	

Bits	Descriptions	
[31:8]	Reserved	Reserved
[7:6]	PWM67_S	<p><b>PWM6 and PWM7 Clock Source Select</b> (NuMicro™ NUC100/NUC120 Medium Density Only)</p> <p>PWM6 and PWM7 used the same Engine clock source, both of them use the same prescaler</p> <p>00 = Clock source from external 4~24 MHz high speed crystal clock</p> <p>01 = Clock source from external 32.768 kHz low speed crystal clock</p> <p>10 = Clock source from HCLK</p> <p>11 = Clock source from internal 22.1184 MHz high speed oscillator clock</p>
[5:4]	PWM45_S	<p><b>PWM4 and PWM5 Clock Source Select</b> (NuMicro™ NUC100/NUC120 Medium Density Only)</p> <p>PWM4 and PWM5 used the same Engine clock source, both of them use the same prescaler</p> <p>00 = Clock source from external 4~24 MHz high speed crystal clock</p> <p>01 = Clock source from external 32.768 kHz low speed crystal clock</p> <p>10 = Clock source from HCLK</p> <p>11 = Clock source from internal 22.1184 MHz high speed oscillator clock</p>
[3:2]	FRQDIV_S	<p><b>Clock Divider Clock Source Select</b></p> <p>00 = Clock source from external 4~24 MHz high speed crystal clock</p> <p>01 = Clock source from external 32.768 kHz low speed crystal clock</p> <p>10 = Clock source from HCLK</p>





Bits	Descriptions	
		11 = Clock source from internal 22.1184 MHz high speed oscillator clock
[1:0]	<b>I2S_S</b>	<b>I<sup>2</sup>S Clock Source Select</b> 00 = Clock source from external 4~24 MHz high speed crystal clock 01 = Clock source from PLL clock 10 = Clock source from HCLK 11 = Clock source from internal 22.1184 MHz high speed oscillator clock



## Clock Divider Register (CLKDIV)

Register	Offset	R/W	Description	Reset Value
CLKDIV	CLK_BA+0x18	R/W	Clock Divider Number Register	0x0000_0000

31	30	29	28	27	26	25	24
Reserved							
23	22	21	20	19	18	17	16
ADC_N							
15	14	13	12	11	10	9	8
Reserved				UART_N			
7	6	5	4	3	2	1	0
USB_N				HCLK_N			

Bits	Descriptions	
[31:24]	Reserved	Reserved
[23:16]	ADC_N	<b>ADC clock divide number from ADC clock source</b> The ADC clock frequency = (ADC clock source frequency) / (ADC_N + 1)
[15:12]	Reserved	Reserved
[11:8]	UART_N	<b>UART clock divide number from UART clock source</b> The UART clock frequency = (UART clock source frequency) / (UART_N + 1)
[7:4]	USB_N	<b>USB clock divide number from PLL clock</b> The USB clock frequency = (PLL frequency) / (USB_N + 1)
[3:0]	HCLK_N	<b>HCLK clock divide number from HCLK clock source</b> The HCLK clock frequency = (HCLK clock source frequency) / (HCLK_N + 1)



## PLL Control Register (PLLCON)

The PLL reference clock input is from the external 4~24 MHz high speed crystal clock input or from the internal 22.1184 MHz high speed oscillator. These registers are use to control the PLL output frequency and PLL operating mode

Register	Offset	R/W	Description	Reset Value
PLLCON	CLK_BA+0x20	R/W	PLL Control Register	0x0005_C22E

31	30	29	28	27	26	25	24
Reserved							
23	22	21	20	19	18	17	16
Reserved				PLL_SRC	OE	BP	PD
15	14	13	12	11	10	9	8
OUT_DV		IN_DV					FB_DV
7	6	5	4	3	2	1	0
FB_DV							

Bits	Descriptions	
[31:20]	Reserved	Reserved
[19]	PLL_SRC	<b>PLL Source Clock Select</b> 1 = PLL source clock from internal 22.1184 MHz high speed oscillator 0 = PLL source clock from external 4~24 MHz high speed crystal
[18]	OE	<b>PLL OE (FOUT enable) pin Control</b> 0 = PLL FOUT enable 1 = PLL FOUT is fixed low
[17]	BP	<b>PLL Bypass Control</b> 0 = PLL is in normal mode (default) 1 = PLL clock output is same as clock input (XTALin)
[16]	PD	<b>Power Down Mode</b> If set the PWR_DOWN_EN bit to 1 in PWRCON register, the PLL will enter power down mode too. 0 = PLL is in normal mode 1 = PLL is in power down mode (default)
[15:14]	OUT_DV	<b>PLL Output Divider Control Pins</b> Refer to the formulas below the table.
[13:9]	IN_DV	<b>PLL Input Divider Control Pins</b> Refer to the formulas below the table.



Bits	Descriptions	
[8:0]	FB_DV	<b>PLL Feedback Divider Control Pins</b> Refer to the formulas below the table.

### Output Clock Frequency Setting

$$F_{OUT} = F_{IN} \times \frac{NF}{NR} \times \frac{1}{NO}$$

Constraint:

1.  $3.2MHz < F_{IN} < 150MHz$
2.  $800 KHz < \frac{F_{IN}}{2 * NR} < 8MHz$
3.  $100 MHz < F_{CO} = F_{IN} \times \frac{NF}{NR} < 200 MHz$   
 $120 MHz < F_{CO}$  is preferred

Symbol	Description
<i>F<sub>OUT</sub></i>	Output Clock Frequency
<i>F<sub>IN</sub></i>	Input (Reference) Clock Frequency
<i>NR</i>	Input Divider (IN_DV + 2)
<i>NF</i>	Feedback Divider (FB_DV + 2)
<i>NO</i>	OUT_DV = "00" : NO = 1 OUT_DV = "01" : NO = 2 OUT_DV = "10" : NO = 2 OUT_DV = "11" : NO = 4

### Default Frequency Setting

The default value : 0xC22E

*F<sub>IN</sub>* = 12 MHz

*NR* = (1+2) = 3

*NF* = (46+2) = 48

*NO* = 4

*F<sub>OUT</sub>* = 12/4 x 48 x 1/3 = 48 MHz



**Frequency Divider Control Register (FRQDIV)**

Register	Offset	R/W	Description	Reset Value
FRQDIV	CLK_BA+ 24	R/W	Frequency Divider Control Register	0x0000_0000

31	30	29	28	27	26	25	24
Reserved							
23	22	21	20	19	18	17	16
Reserved							
15	14	13	12	11	10	9	8
Reserved							
7	6	5	4	3	2	1	0
Reserved			DIVIDER_EN	FSEL			

Bits	Descriptions	
[31:5]	Reserved	Reserved
[4]	DIVIDER_EN	<p><b>Frequency Divider Enable Bit</b></p> <p>0 = Disable Frequency Divider 1 = Enable Frequency Divider</p>
[3:0]	FSEL	<p><b>Divider Output Frequency Selection Bits</b></p> <p>The formula of output frequency is</p> $F_{out} = F_{in}/2^{(N+1)}$ <p><math>F_{in}</math> is the input clock frequency. <math>F_{out}</math> is the frequency of divider output clock. N is the 4-bit value of FSEL[3:0].</p>

## 5.4 USB Device Controller (USB)

### 5.4.1 Overview

There is one set of USB 2.0 full-speed device controller and transceiver in this device. It is compliant with USB 2.0 full-speed device specification and support control/bulk/interrupt/isochronous transfer types.

In this device controller, there are two main interfaces: the APB bus and USB bus which comes from the USB PHY transceiver. For the APB bus, the CPU can program control registers through it. There are 512 bytes internal SRAM as data buffer in this controller. For IN or OUT transfer, it is necessary to write data to SRAM or read data from SRAM through the APB interface or SIE. Users need to set the effective starting address of SRAM for each endpoint buffer through “buffer segmentation register (USB\_BUFSEGx)”.

There are 6 endpoints in this controller. Each of the endpoint can be configured as IN or OUT endpoint. All the operations including Control, Bulk, Interrupt and Isochronous transfer are implemented in this block. The block of ENDPOINT CONTROL is also used to manage the data sequential synchronization, endpoint states, current start address, transaction status, and data buffer status for each endpoint.

There are four different interrupt events in this controller. They are the wake-up function, device plug-in or plug-out event, USB events, like IN ACK, OUT ACK etc, and BUS events, like suspend and resume, etc. Any event will cause an interrupt, and users just need to check the related event flags in interrupt event status register (USB\_INTSTS) to acknowledge what kind of interrupt occurring, and then check the related USB Endpoint Status Register (USB\_EPSTS) to acknowledge what kind of event occurring in this endpoint.

A software-disable function is also supported for this USB controller. It is used to simulate the disconnection of this device from the host. If user enables DRVSE0 bit (USB\_DRVSE0), the USB controller will force the output of USB\_DP and USB\_DM to level low and its function is disabled. After disable the DRVSE0 bit, host will enumerate the USB device again.

Reference: Universal Serial Bus Specification Revision 1.1

### 5.4.2 Features

This Universal Serial Bus (USB) performs a serial interface with a single connector type for attaching all USB peripherals to the host system. Following is the feature listing of this USB.

- Compliant with USB 2.0 Full-Speed specification
- Provide 1 interrupt vector with 4 different interrupt events (WAKEUP, FLDET, USB and BUS)
- Support Control/Bulk/Interrupt/Isochronous transfer type
- Support suspend function when no bus activity existing for 3 ms
- Provide 6 endpoints for configurable Control/Bulk/Interrupt/Isochronous transfer types and maximum 512 bytes buffer size
- Provide remote wake-up capability

5.4.3 Block Diagram

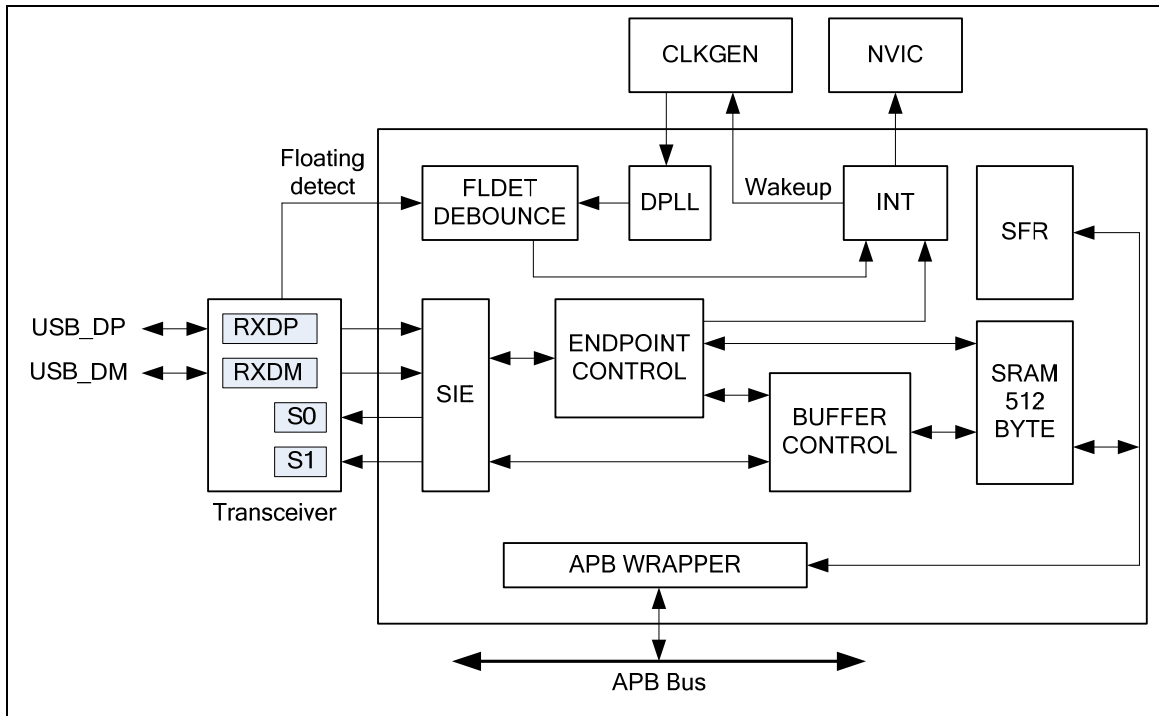

Figure 5-10 USB Block Diagram

## 5.4.4 Function Description

### 5.4.4.1 SIE (Serial Interface Engine)

The SIE is the front-end of the device controller and handles most of the USB packet protocol. The SIE typically comprehends signaling up to the transaction level. The functions that it handles could include:

- Packet recognition, transaction sequencing
- SOP, EOP, RESET, RESUME signal detection/generation
- Clock/Data separation
- NRZI Data encoding/decoding and bit-stuffing
- CRC generation and checking (for Token and Data)
- Packet ID (PID) generation and checking/ decoding
- Serial-Parallel/ Parallel-Serial conversion

### 5.4.4.2 Endpoint Control

There are 6 endpoints in this controller. Each of the endpoint can be configured as Control, Bulk, Interrupt, or Isochronous transfer type. All the operations including Control, Bulk, Interrupt and Isochronous transfer are implemented in this block. It is also used to manage the data sequential synchronization, endpoint state control, current endpoint start address, current transaction status, and data buffer status in each endpoint.

### 5.4.4.3 Digital Phase Lock Loop

The bit rate of USB data is 12 MHz. The DPLL use the 48 MHz which comes from the clock controller to lock the input data RXDP and RXDM. The 12 MHz bit rate clock is also converted from DPLL.

### 5.4.4.4 Floating De-bounce

A USB device may be plug-in or plug-out from the USB host. In order to monitor the state of a USB device when it is detached from the USB host, the device controller provides hardware de-bounce for USB floating detect interrupt to avoid bounce problems on USB plug-in or unplug. Floating detect interrupt appears about 10 ms later than USB plug-in or plug-out. A user can acknowledge USB plug-in/plug-out by reading register "USB\_FLDET". The flag in "FLDET" represents the current state on the bus without de-bounce. If the FLDET is 1, it means the controller has plug-in the USB. If the user polling this flag to check USB state, he/she must add software de-bounce if necessary.



#### 5.4.4.5 Interrupt

This USB provides 1 interrupt vector with 4 interrupt events (WAKEUP, FLDET, USB and BUS). The WAKEUP event is used to wake-up the system clock when the power down mode is enabled. (The power mode function is defined in system power down control register, PWRCON). The FLDET event is used for USB plug-in or unplug. The USB event notifies users of some USB requests, like IN ACK, OUT ACK etc., and the BUS event notifies users of some bus events, like suspend, resume, etc. User must set related bits in the interrupt enable register (USB\_INTEN) of USB Device Controller to enable USB interrupts.

Wake-up interrupt is only present when the chip entered power down mode and then wake-up event had happened. After the chip enters power down mode, any change on USB\_DP and USB\_DM can wake-up this chip (provided that USB wake-up function is enabled). If this change is not intentionally, no interrupt but wake-up interrupt will occur. After USB wake-up, this interrupt will occur when no other USB interrupt events are present for more than 20ms. The following figure is the control flow of wake-up interrupt.

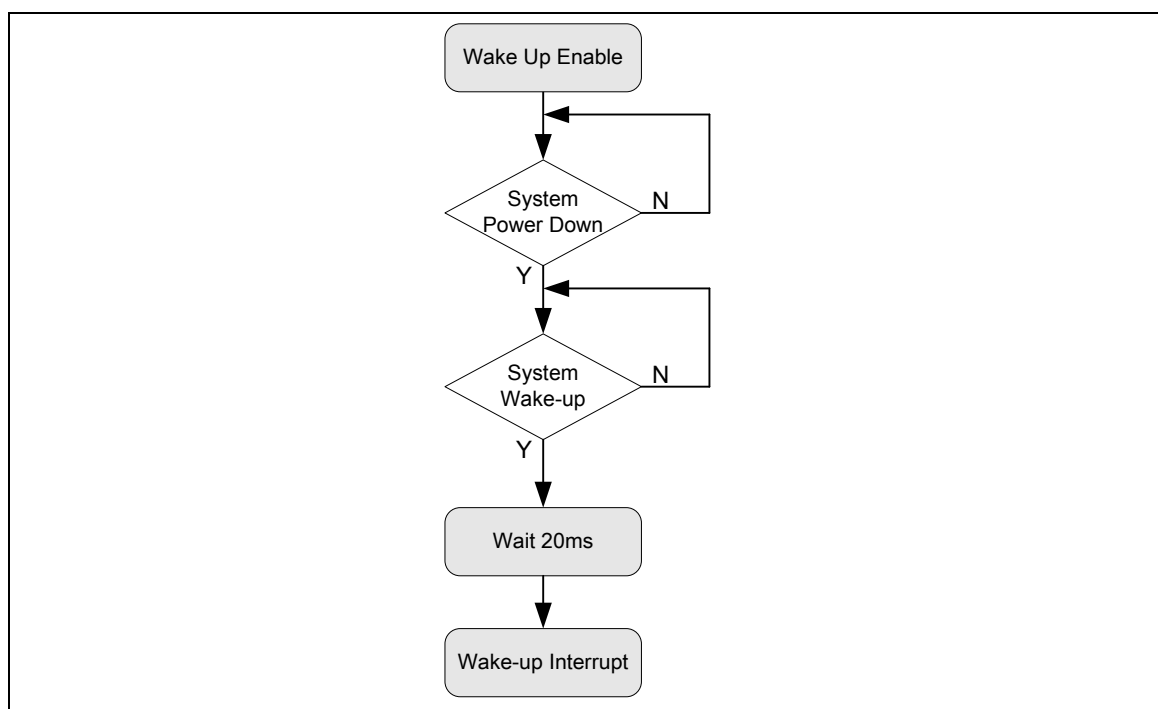

Figure 5-11 Wake-up Interrupt Operation Flow

USB interrupt is used to notify users of any USB event on the bus, and a user can read EPSTS (USB\_EPSTS[25:8]) and EPEVT5~0 (USB\_INTSTS[21:16]) to know what kind of request is to which endpoint and take necessary responses.

Same as USB interrupt, BUS interrupt notifies users of some bus events, like USB reset, suspend, time-out, and resume. A user can read USB\_ATTR to acknowledge bus events.



### 5.4.4.6 Power Saving

USB turns off PHY transceiver automatically to save power while this chip enters power down mode. Furthermore, a user can write 0 into USB\_ATTR[4] to turn off PHY under special circumstances like suspend to save power.

### 5.4.4.7 Buffer Control

There is 512 bytes SRAM in the controller and the 6 endpoints share this buffer. The user shall configure each endpoint's effective starting address in the buffer segmentation register before the USB function active. The BUFFER CONTROL block is used to control each endpoint's effective starting address and its SRAM size is defined in the MXPLD register.

Figure 5-12 depicts the starting address for each endpoint according the content of USB\_BUFSEGx and USB\_MXPLDx registers. If the USB\_BUFSEG0 is programmed as 0x08h and USB\_MXPLD0 is set as 0x40h, the SRAM size of endpoint 0 is start from USB\_BA+0x108h and end in USB\_BA+0x148h. (Note: the USB SRAM base is USB\_BA+0x100h).

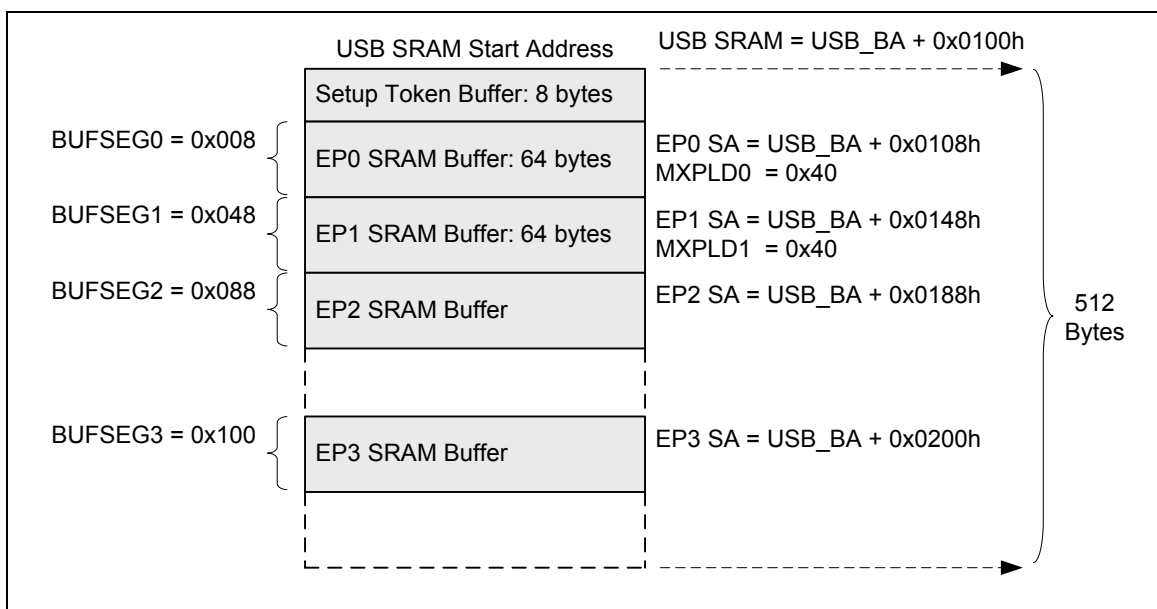

Figure 5-12 Endpoint SRAM Structure

## 5.4.4.8 Handling Transactions with USB Device Peripheral

User can use interrupt or polling USB\_INTSTS to monitor the USB Transactions, when transactions occur, USB\_INTSTS will be set by hardware and send an interrupt request to CPU (if related interrupt enabled), or user can polling USB\_INTSTS to get these events without interrupt. The following is the control flow with interrupt enable.

When USB host has requested data from device controller, users need to prepare related data into the specified endpoint buffer in advance. After buffering the required data, users need to write the actual data length in the specified MAXPLD register. Once this register is written, the internal signal "In\_Rdy" will be asserted and the buffering data will be transmitted immediately after receiving associated IN token from Host. Note that after transferring the specified data, the signal "In\_Rdy" will de-assert automatically by hardware.

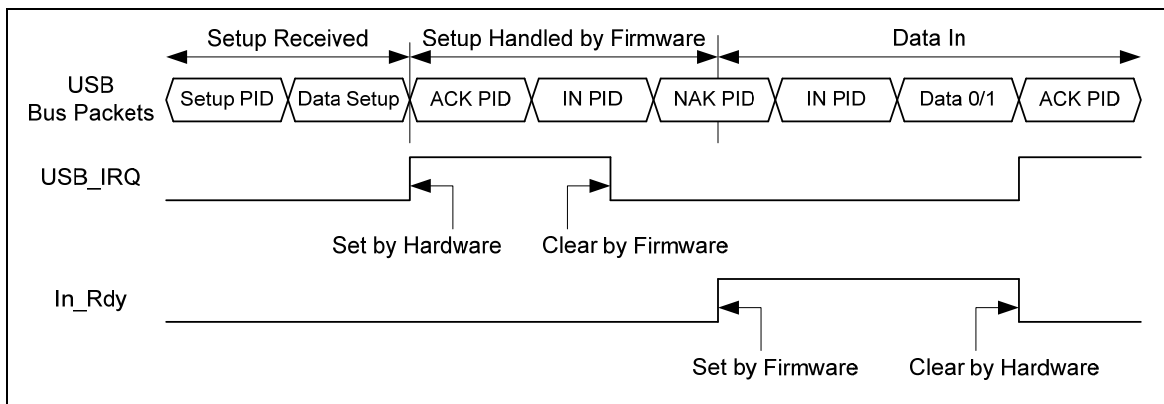

Figure 5-13 Setup Transaction followed by Data in Transaction

Alternatively, when USB host wants to transmit data to the OUT endpoint in the device controller, hardware will buffer these data to the specified endpoint buffer. After this transaction is completed, hardware will record the data length in related MAXPLD register and de-assert the signal "Out\_Rdy". This will avoid hardware accepting next transaction until users move out current data in the related endpoint buffer. Once users have processed this transaction, the related register "MAXPLD" needs to be written by firmware to assert the signal "Out\_Rdy" again to accept next transaction.

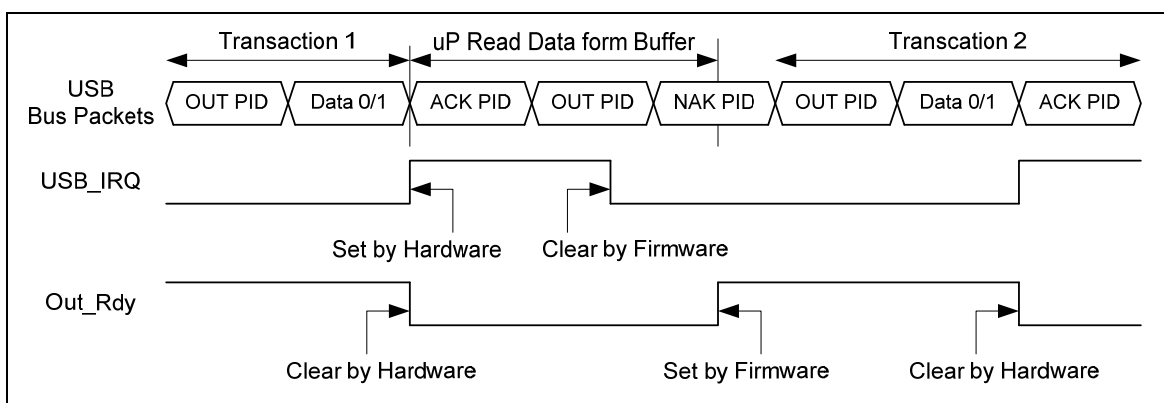



Figure 5-14 Data Out Transfer

## 5.4.5 Register and Memory Map

R: read only, W: write only, R/W: both read and write

Register	Offset	R/W	Description	Reset Value
<b>USB_BA = 0x4006_0000</b>				
USB_INTEN	USB_BA+0x000	R/W	USB Interrupt Enable Register	0x0000_0000
USB_INTSTS	USB_BA+0x004	R/W	USB Interrupt Event Status Register	0x0000_0000
USB_FADDR	USB_BA+0x008	R/W	USB Device Function Address Register	0x0000_0000
USB_EPSTS	USB_BA+0x00C	R	USB Endpoint Status Register	0x0000_00x0
USB_ATTR	USB_BA+0x010	R/W	USB Bus Status and Attribution Register	0x0000_0040
USB_FLDET	USB_BA+0x014	R	USB Floating Detected Register	0x0000_0000
USB_STBUFSEG	USB_BA+0x018	R/W	Setup Token Buffer Segmentation Register	0x0000_0000
USB_BUFSEG0	USB_BA+0x020	R/W	Endpoint 0 Buffer Segmentation Register	0x0000_0000
USB_MXPLD0	USB_BA+0x024	R/W	Endpoint 0 Maximal Payload Register	0x0000_0000
USB_CFG0	USB_BA+0x028	R/W	Endpoint 0 Configuration Register	0x0000_0000
USB_CFGP0	USB_BA+0x02C	R/W	Endpoint 0 Set Stall and Clear In/Out Ready Control Register	0x0000_0000
USB_BUFSEG1	USB_BA+0x030	R/W	Endpoint 1 Buffer Segmentation Register	0x0000_0000
USB_MXPLD1	USB_BA+0x034	R/W	Endpoint 1 Maximal Payload Register	0x0000_0000
USB_CFG1	USB_BA+0x038	R/W	Endpoint 1 Configuration Register	0x0000_0000
USB_CFGP1	USB_BA+0x03C	R/W	Endpoint 1 Set Stall and Clear In/Out Ready Control Register	0x0000_0000
USB_BUFSEG2	USB_BA+0x040	R/W	Endpoint 2 Buffer Segmentation Register	0x0000_0000
USB_MXPLD2	USB_BA+0x044	R/W	Endpoint 2 Maximal Payload Register	0x0000_0000
USB_CFG2	USB_BA+0x048	R/W	Endpoint 2 Configuration Register	0x0000_0000
USB_CFGP2	USB_BA+0x04C	R/W	Endpoint 2 Set Stall and Clear In/Out Ready Control Register	0x0000_0000
USB_BUFSEG3	USB_BA+0x050	R/W	Endpoint 3 Buffer Segmentation Register	0x0000_0000
USB_MXPLD3	USB_BA+0x054	R/W	Endpoint 3 Maximal Payload Register	0x0000_0000
USB_CFG3	USB_BA+0x058	R/W	Endpoint 3 Configuration Register	0x0000_0000
USB_CFGP3	USB_BA+0x05C	R/W	Endpoint 3 Set Stall and Clear In/Out Ready Control Register	0x0000_0000



Register	Offset	R/W	Description	Reset Value
USB_BUFSEG4	USB_BA+0x060	R/W	Endpoint 4 Buffer Segmentation Register	0x0000_0000
USB_MXPLD4	USB_BA+0x064	R/W	Endpoint 4 Maximal Payload Register	0x0000_0000
USB_CFG4	USB_BA+0x068	R/W	Endpoint 4 Configuration Register	0x0000_0000
USB_CFGP4	USB_BA+0x06C	R/W	Endpoint 4 Set Stall and Clear In/Out Ready Control Register	0x0000_0000
USB_BUFSEG5	USB_BA+0x070	R/W	Endpoint 5 Buffer Segmentation Register	0x0000_0000
USB_MXPLD5	USB_BA+0x074	R/W	Endpoint 5 Maximal Payload Register	0x0000_0000
USB_CFG5	USB_BA+0x078	R/W	Endpoint 5 Configuration Register	0x0000_0000
USB_CFGP5	USB_BA+0x07C	R/W	Endpoint 5 Set Stall and Clear In/Out Ready Control Register	0x0000_0000
USB_DRVSE0	USB_BA+0x090	R/W	USB Drive SE0 Control Register	0x0000_0001

Memory Type	Address	Size	Description
<b>USB_BA = 0x4006_0000</b>			
SRAM	USB_BA+0x100 ~ USB_BA+0x2FF	512 Bytes	The SRAM is used for the entire endpoints buffer. Refer to section 5.4.4.7 for the endpoint SRAM structure and its description.



5.4.6 Register Description

**USB Interrupt Enable Register (USB\_INTEN)**

Register	Offset	R/W	Description	Reset Value
USB_INTEN	USB_BA+0x000	R/W	USB Interrupt Enable Register	0x0000_0000

31	30	29	28	27	26	25	24
Reserved							
23	22	21	20	19	18	17	16
Reserved							
15	14	13	12	11	10	9	8
INNAK_EN	Reserved						WAKEUP_EN
7	6	5	4	3	2	1	0
Reserved				WAKEUP_IE	FLDET_IE	USB_IE	BUS_IE

Bits	Descriptions	
[31:16]	Reserved	Reserved
[15]	INNAK_EN	<b>Active NAK Function and its Status in IN Token</b> 1 = The NAK status is updated into the endpoint status register, USB_EPSTS, when it is set to 1 and there is NAK response in IN token. It also enable the interrupt event when the device responds NAK after receiving IN token 0 = The NAK status doesn't be updated into the endpoint status register when it was set to 0. It also disable the interrupt event when device responds NAK after receiving IN token
[14:9]	Reserved	Reserved
[8]	WAKEUP_EN	<b>Wake-up Function Enable</b> 1 = Enable USB wake-up function 0 = Disable USB wake-up function
[7:4]	Reserved	Reserved
[3]	WAKEUP_IE	<b>USB Wake-up Interrupt Enable</b> 1 = Enable wake-up Interrupt 0 = Disable wake-up Interrupt
[2]	FLDET_IE	<b>Floating Detected Interrupt Enable</b> 1 = Enable Floating detect Interrupt 0 = Disable Floating detect Interrupt
[1]	USB_IE	<b>USB Event Interrupt Enable</b> 1 = Enable USB event interrupt 0 = Disable USB event interrupt
[0]	BUS_IE	<b>Bus Event Interrupt Enable</b> 1 = Enable BUS event interrupt 0 = Disable BUS event interrupt



## USB Interrupt Event Status Register (USB\_INTSTS)

This register is USB Interrupt Event Status register; clear by write '1' to the corresponding bit.

Register	Offset	R/W	Description	Reset Value
USB_INTSTS	USB_BA+0x004	R/W	USB Interrupt Event Status Register	0x0000_0000

31	30	29	28	27	26	25	24
SETUP		Reserved					
23	22	21	20	19	18	17	16
Reserved		EPEVT5	EPEVT4	EPEVT3	EPEVT2	EPEVT1	EPEVT0
15	14	13	12	11	10	9	8
Reserved							
7	6	5	4	3	2	1	0
Reserved				WAKEUP_ST S	FLDET_ST S	USB_ST S	BUS_ST S

Bits	Descriptions	
[31]	SETUP	<b>Setup Event Status</b> 1 = Setup event occurred, cleared by write 1 to USB_INTSTS[31] 0 = No Setup event
[30:22]	Reserved	Reserved
[21]	EPEVT5	<b>Endpoint 5's USB Event Status</b> 1 = USB event occurred on Endpoint 5, check USB_EPSTS[25:23] to know which kind of USB event was occurred, cleared by write 1 to USB_INTSTS[21] or USB_INTSTS[1] 0 = No event occurred in endpoint 5
[20]	EPEVT4	<b>Endpoint 4's USB Event Status</b> 1 = USB event occurred on Endpoint 4, check USB_EPSTS[22:20] to know which kind of USB event was occurred, cleared by write 1 to USB_INTSTS[20] or USB_INTSTS[1] 0 = No event occurred in endpoint 4
[19]	EPEVT3	<b>Endpoint 3's USB Event Status</b> 1 = USB event occurred on Endpoint 3, check USB_EPSTS[19:17] to know which kind of USB event was occurred, cleared by write 1 to USB_INTSTS[19] or USB_INTSTS[1] 0 = No event occurred in endpoint 3
[18]	EPEVT2	<b>Endpoint 2's USB Event Status</b> 1 = USB event occurred on Endpoint 2, check USB_EPSTS[16:14] to know which kind of USB event was occurred, cleared by write 1 to USB_INTSTS[18] or



Bits	Descriptions	
		USB_INTSTS[1] 0 = No event occurred in endpoint 2
[17]	<b>EPEVT1</b>	<b>Endpoint 1's USB Event Status</b> 1 = USB event occurred on Endpoint 1, check USB_EPSTS[13:11] to know which kind of USB event was occurred, cleared by write 1 to USB_INTSTS[17] or USB_INTSTS[1] 0 = No event occurred in endpoint 1
[16]	<b>EPEVT0</b>	<b>Endpoint 0's USB Event Status</b> 1 = USB event occurred on Endpoint 0, check USB_EPSTS[10:8] to know which kind of USB event was occurred, cleared by write 1 to USB_INTSTS[16] or USB_INTSTS[1] 0 = No event occurred in endpoint 0
[15:4]	<b>Reserved</b>	Reserved
[3]	<b>WAKEUP_STS</b>	<b>Wake-up Interrupt Status</b> 1 = Wake-up event occurred, cleared by write 1 to USB_INTSTS[3] 0 = No Wake-up event is occurred
[2]	<b>FLDET_STS</b>	<b>Floating Detected Interrupt Status</b> 1 = There is attached/detached event in the USB bus and it is cleared by write 1 to USB_INTSTS[2]. 0 = There is not attached/detached event in the USB
[1]	<b>USB_STS</b>	<b>USB event Interrupt Status</b> The USB event includes the Setup Token, IN Token, OUT ACK, ISO IN, or ISO OUT events in the bus. 1 = USB event occurred, check EPSTS0~5[2:0] to know which kind of USB event was occurred, cleared by write 1 to USB_INTSTS[1] or EPSTS0~5 and SETUP (USB_INTSTS[31]) 0 = No any USB event is occurred
[0]	<b>BUS_STS</b>	<b>BUS Interrupt Status</b> The BUS event means that there is one of the suspense or the resume function in the bus. 1 = Bus event occurred; check USB_ATTR[3:0] to know which kind of bus event was occurred, cleared by write 1 to USB_INTSTS[0]. 0 = No any BUS event is occurred





## USB Device Function Address Register (USB\_FADDR)

A seven-bit value uses as the address of a device on the USB BUS.

Register	Offset	R/W	Description	Reset Value
USB_FADDR	USB_BA+0x008	R/W	USB Device Function Address Register	0x0000_0000

31	30	29	28	27	26	25	24
Reserved							
23	22	21	20	19	18	17	16
Reserved							
15	14	13	12	11	10	9	8
Reserved							
7	6	5	4	3	2	1	0
Reserved	FADDR						

Bits	Descriptions	
[31:7]	Reserved	Reserved
[6:0]	FADDR	USB device's Function Address



**USB Endpoint Status Register (USB\_EPSTS)**

Register	Offset	R/W	Description	Reset Value
USB_EPSTS	USB_BA+0x00C	R	USB Endpoint Status Register	0x0000_0000

31	30	29	28	27	26	25	24
Reserved						EPSTS5[2:1]	
23	22	21	20	19	18	17	16
EPSTS5[0]	EPSTS4[2:0]			EPSTS3[2:0]			EPSTS2[2]
15	14	13	12	11	10	9	8
EPSTS2[1:0]		EPSTS1[2:0]			EPSTS0[2:0]		
7	6	5	4	3	2	1	0
OVERRUN	Reserved						

Bits	Descriptions	
[31:26]	Reserved	Reserved
[25:23]	EPSTS5	<p><b>Endpoint 5 Bus Status</b></p> <p>These bits are used to indicate the current status of this endpoint</p> <p>000 = In ACK                      001 = In NAK                      010 = Out Packet Data0 ACK                      110 = Out Packet Data1 ACK                      011 = Setup ACK                      111 = Isochronous transfer end</p>
[22:20]	EPSTS4	<p><b>Endpoint 4 Bus Status</b></p> <p>These bits are used to indicate the current status of this endpoint</p> <p>000 = In ACK                      001 = In NAK                      010 = Out Packet Data0 ACK                      110 = Out Packet Data1 ACK                      011 = Setup ACK                      111 = Isochronous transfer end</p>
[19:17]	EPSTS3	<p><b>Endpoint 3 Bus Status</b></p> <p>These bits are used to indicate the current status of this endpoint</p> <p>000 = In ACK                      001 = In NAK                      010 = Out Packet Data0 ACK</p>



Bits	Descriptions	
		110 = Out Packet Data1 ACK 011 = Setup ACK 111 = Isochronous transfer end
[16:14]	<b>EPSTS2</b>	<b>Endpoint 2 Bus Status</b> These bits are used to indicate the current status of this endpoint 000 = In ACK 001 = In NAK 010 = Out Packet Data0 ACK 110 = Out Packet Data1 ACK 011 = Setup ACK 111 = Isochronous transfer end
[13:11]	<b>EPSTS1</b>	<b>Endpoint 1 Bus Status</b> These bits are used to indicate the current status of this endpoint 000 = In ACK 001 = In NAK 010 = Out Packet Data0 ACK 110 = Out Packet Data1 ACK 011 = Setup ACK 111 = Isochronous transfer end
[10:8]	<b>EPSTS0</b>	<b>Endpoint 0 Bus Status</b> These bits are used to indicate the current status of this endpoint 000 = In ACK 001 = In NAK 010 = Out Packet Data0 ACK 110 = Out Packet Data1 ACK 011 = Setup ACK 111 = Isochronous transfer end
[7]	<b>OVERRUN</b>	<b>Overrun</b> It indicates that the received data is over the maximum payload number or not. 1 = It indicates that the Out Data more than the Max Payload in MXPLD register or the Setup Data more than 8 Bytes 0 = No overrun
[6:0]	<b>Reserved</b>	Reserved



## USB Bus Status and Attribution Register (USB\_ATTR)

Register	Offset	R/W	Description	Reset Value
USB_ATTR	USB_BA+0x010	R/W	USB Bus Status and Attribution Register	0x0000_0040

31	30	29	28	27	26	25	24
Reserved							
23	22	21	20	19	18	17	16
Reserved							
15	14	13	12	11	10	9	8
Reserved					BYTEM	PWRDN	DPPU_EN
7	6	5	4	3	2	1	0
USB_EN	Reserved	RWAKEUP	PHY_EN	TIMEOUT	RESUME	SUSPEND	USBRST

Bits	Descriptions	
[31:11]	Reserved	Reserved
[10]	BYTEM	<b>CPU access USB SRAM Size Mode Select</b> 1 = Byte Mode: The size of the transfer from CPU to USB SRAM can be Byte only. 0 = Word Mode: The size of the transfer from CPU to USB SRAM can be Word only.
[9]	PWRDN	<b>Power down PHY Transceiver, low active</b> 1 = Turn-on related circuit of PHY transceiver 0 = power down related circuit of PHY transceiver
[8]	DPPU_EN	<b>Pull-up resistor on USB_DP enable</b> 1 = The pull-up resistor in USB_DP bus active 0 = Disable the pull-up resistor in USB_DP bus
[7]	USB_EN	<b>USB Controller Enable</b> 1 = Enable USB Controller 0 = Disable USB Controller
[6]	Reserved	Reserved
[5]	RWAKEUP	<b>Remote wake-up</b> 1 = Force USB bus to K (USB_DP low, USB_DM: high) state, used for remote wake-up 0 = Release the USB bus from K state
[4]	PHY_EN	<b>PHY Transceiver Function Enable</b> 1 = Enable PHY transceiver function 0 = Disable PHY transceiver function



Bits	Descriptions	
[3]	<b>TIMEOUT</b>	<b>Time Out Status</b> 1 = Bus no any response more than 18 bits time 0 = No time out It is a read only bit.
[2]	<b>RESUME</b>	<b>Resume Status</b> 1 = Resume from suspend 0 = No bus resume It is a read only bit.
[1]	<b>SUSPEND</b>	<b>Suspend Status</b> 1 = Bus idle more than 3ms, either cable is plugged off or host is sleeping 0 = Bus no suspend It is a read only bit.
[0]	<b>USBRST</b>	<b>USB Reset Status</b> 1 = Bus reset when SE0 (single-ended 0) more than 2.5us 0 = Bus no reset It is a read only bit.



## Floating detection Register (USB\_FLDET)

Register	Offset	R/W	Description	Reset Value
USB_FLDET	USB_BA+0x014	R	USB Floating Detected Register	0x0000_0000

31	30	29	28	27	26	25	24
Reserved							
23	22	21	20	19	18	17	16
Reserved							
15	14	13	12	11	10	9	8
Reserved							
7	6	5	4	3	2	1	0
Reserved							FLDET

Bits	Descriptions	
[31:1]	Reserved	Reserved
[0]	FLDET	<b>Device Floating Detected</b> 1 = When the controller is attached into the BUS, this bit will be set as 1 0 = The controller didn't attached into the USB host



## Buffer Segmentation Register (USB\_STBUFSEG)

For Setup token only.

Register	Offset	R/W	Description	Reset Value
USB_STBUFSEG	USB_BA+0x018	R/W	Setup Token Buffer segmentation Register	0x0000_0000

31	30	29	28	27	26	25	24
Reserved							
23	22	21	20	19	18	17	16
Reserved							
15	14	13	12	11	10	9	8
Reserved							STBUFSEG[8 ]
7	6	5	4	3	2	1	0
STBUFSEG[7:3]					Reserved		

Bits	Descriptions	
[31:9]	Reserved	Reserved
[8:3]	STBUFSEG	It is used to indicate the offset address for the Setup token with the USB SRAM starting address. The effective starting address is USB_SRAM address + { STBUFSEG[8:3], 3'b000} Where the USB_SRAM address = USB_BA+0x100h. Note: It is used for Setup token only.
[2:0]	Reserved	Reserved



## Buffer Segmentation Register (BUFSEGx)

Register	Offset	R/W	Description	Reset Value
USB_BUFSEG0	USB_BA+0x020	R/W	Endpoint 0 Buffer Segmentation Register	0x0000_0000
USB_BUFSEG1	USB_BA+0x030	R/W	Endpoint 1 Buffer Segmentation Register	0x0000_0000
USB_BUFSEG2	USB_BA+0x040	R/W	Endpoint 2 Buffer Segmentation Register	0x0000_0000
USB_BUFSEG3	USB_BA+0x050	R/W	Endpoint 3 Buffer Segmentation Register	0x0000_0000
USB_BUFSEG4	USB_BA+0x060	R/W	Endpoint 4 Buffer Segmentation Register	0x0000_0000
USB_BUFSEG5	USB_BA+0x070	R/W	Endpoint 5 Buffer Segmentation Register	0x0000_0000

31	30	29	28	27	26	25	24
Reserved							
23	22	21	20	19	18	17	16
Reserved							
15	14	13	12	11	10	9	8
Reserved							BUFSEG[8]
7	6	5	4	3	2	1	0
BUFSEG[7:3]					Reserved		

Bits	Descriptions	
[31:9]	Reserved	Reserved
[8:3]	BUFSEG	It is used to indicate the offset address for each endpoint with the USB SRAM starting address. The effective starting address of the endpoint is USB_SRAM address + { BUFSEG[8:3], 3'b000} Where the USB_SRAM address = USB_BA+0x100h. Refer to section 5.4.4.7 for the endpoint SRAM structure and its description.
[2:0]	Reserved	Reserved





## Maximal Payload Register (USB\_MXPLDx)

Register	Offset	R/W	Description	Reset Value
USB_MXPLD0	USB_BA+0x024	R/W	Endpoint 0 Maximal Payload Register	0x0000_0000
USB_MXPLD1	USB_BA+0x034	R/W	Endpoint 1 Maximal Payload Register	0x0000_0000
USB_MXPLD2	USB_BA+0x044	R/W	Endpoint 2 Maximal Payload Register	0x0000_0000
USB_MXPLD3	USB_BA+0x054	R/W	Endpoint 3 Maximal Payload Register	0x0000_0000
USB_MXPLD4	USB_BA+0x064	R/W	Endpoint 4 Maximal Payload Register	0x0000_0000
USB_MXPLD5	USB_BA+0x074	R/W	Endpoint 5 Maximal Payload Register	0x0000_0000

31	30	29	28	27	26	25	24
Reserved							
23	22	21	20	19	18	17	16
Reserved							
15	14	13	12	11	10	9	8
Reserved							MXPLD[8]
7	6	5	4	3	2	1	0
MXPLD[7:0]							

Bits	Descriptions	
[31:9]	Reserved	Reserved
[8:0]	MXPLD	<p><b>Maximal Payload</b></p> <p>It is used to define the data length which is transmitted to host (IN token) or the actual data length which is received from the host (OUT token). It also used to indicate that the endpoint is ready to be transmitted in IN token or received in OUT token.</p> <p>(1). When the register is written by CPU, For IN token, the value of MXPLD is used to define the data length to be transmitted and indicate the data buffer is ready.</p> <p>For OUT token, it means that the controller is ready to receive data from the host and the value of MXPLD is the maximal data length comes from host.</p> <p>(2). When the register is read by CPU, For IN token, the value of MXPLD is indicated the data length be transmitted to host For OUT token, the value of MXPLD is indicated the actual data length receiving from host.</p> <p>Note that once MXPLD is written, the data packets will be transmitted/received immediately after IN/OUT token arrived.</p>



**Configuration Register (USB\_CFGx)**

Register	Offset	R/W	Description	Reset Value
USB_CFG0	USB_BA+0x028	R/W	Endpoint 0's Configuration Register	0x0000_0000
USB_CFG1	USB_BA+0x038	R/W	Endpoint 1's Configuration Register	0x0000_0000
USB_CFG2	USB_BA+0x048	R/W	Endpoint 2's Configuration Register	0x0000_0000
USB_CFG3	USB_BA+0x058	R/W	Endpoint 3's Configuration Register	0x0000_0000
USB_CFG4	USB_BA+0x068	R/W	Endpoint 4's Configuration Register	0x0000_0000
USB_CFG5	USB_BA+0x078	R/W	Endpoint 5's Configuration Register	0x0000_0000

31	30	29	28	27	26	25	24
Reserved							
23	22	21	20	19	18	17	16
Reserved							
15	14	13	12	11	10	9	8
Reserved						CSTALL	Reserved
7	6	5	4	3	2	1	0
DSQ_SYNC	STATE		ISOCH	EP_NUM			

Bits	Descriptions	
[31:10]	Reserved	Reserved
[9]	CSTALL	<b>Clear STALL Response</b> 1 = Clear the device to response STALL handshake in setup stage 0 = Disable the device to clear the STALL handshake in setup stage
[8]	Reserved	Reserved
[7]	DSQ_SYNC	<b>Data Sequence Synchronization</b> 1 = DATA1 PID 0 = DATA0 PID It is used to specify the DATA0 or DATA1 PID in the following IN token transaction. H/W will toggle automatically in IN token base on the bit.
[6:5]	STATE	<b>Endpoint STATE</b> 00 = Endpoint is disabled 01 = Out endpoint 10 = IN endpoint



Bits	Descriptions	
		11 = Undefined
[4]	<b>ISOCH</b>	<b>Isochronous Endpoint</b> This bit is used to set the endpoint as Isochronous endpoint, no handshake. 1 = Isochronous endpoint 0 = No Isochronous endpoint
[3:0]	<b>EP_NUM</b>	<b>Endpoint Number</b> These bits are used to define the endpoint number of the current endpoint



## Extra Configuration Register (USB\_CFGPx)

Register	Offset	R/W	Description	Reset Value
USB_CFGP0	USB_BA+0x02C	R/W	Endpoint 0 Set Stall and Clear In/Out Ready Control Register	0x0000_0000
USB_CFGP1	USB_BA+0x03C	R/W	Endpoint 1 Set Stall and Clear In/Out Ready Control Register	0x0000_0000
USB_CFGP2	USB_BA+0x04C	R/W	Endpoint 2 Set Stall and Clear In/Out Ready Control Register	0x0000_0000
USB_CFGP3	USB_BA+0x05C	R/W	Endpoint 3 Set Stall and Clear In/Out Ready Control Register	0x0000_0000
USB_CFGP4	USB_BA+0x06C	R/W	Endpoint 4 Set Stall and Clear In/Out Ready Control Register	0x0000_0000
USB_CFGP5	USB_BA+0x07C	R/W	Endpoint 5 Set Stall and Clear In/Out Ready Control Register	0x0000_0000

31	30	29	28	27	26	25	24
Reserved							
23	22	21	20	19	18	17	16
Reserved							
15	14	13	12	11	10	9	8
Reserved							
7	6	5	4	3	2	1	0
Reserved						SSTALL	CLRDRY

Bits	Descriptions	
[31:2]	Reserved	Reserved
[1]	SSTALL	<p><b>Set STALL</b></p> <p>1 = Set the device to respond STALL automatically</p> <p>0 = Disable the device to response STALL</p>
[0]	CLRDRY	<p><b>Clear Ready</b></p> <p>When the MXPLD register is set by user, it means that the endpoint is ready to transmit or receive data. If the user wants to turn off this transaction before the transaction start, users can set this bit to 1 to turn it off and it is auto clear to 0.</p> <p>For IN token, write '1' is used to clear the IN token had ready to transmit the data to USB.</p> <p>For OUT token, write '1' is used to clear the OUT token had ready to receive the data from USB.</p> <p>This bit is write 1 only and it is always 0 when it was read back.</p>



## USB Drive SE0 Register (USB\_DRVSE0)

Register	Offset	R/W	Description	Reset Value
USB_DRVSE0	USB_BA+0x090	R/W	Force USB PHY to drive SE0	0x0000_0001

31	30	29	28	27	26	25	24
Reserved							
23	22	21	20	19	18	17	16
Reserved							
15	14	13	12	11	10	9	8
Reserved							
7	6	5	4	3	2	1	0
Reserved							DRVSE0

Bits	Descriptions	
[31:1]	<b>Reserved</b>	Reserved
[0]	<b>DRVSE0</b>	<p><b>Drive Single Ended Zero in USB Bus</b></p> <p>The Single Ended Zero (SE0) is when both lines (USB_DP and USB_DM) are being pulled low.</p> <p>1 = Force USB PHY transceiver to drive SE0</p> <p>0 = None</p>

## 5.5 General Purpose I/O (GPIO)

### 5.5.1 Overview

NuMicro™ NUC100/NUC120 Medium Density has up to 80 General Purpose I/O pins can be shared with other function pins; it depends on the chip configuration. These 80 pins are arranged in 5 ports named with GPIOA, GPIOB, GPIOC, GPIOD and GPIOE. Each port equips maximum 16 pins. Each one of the 80 pins is independent and has the corresponding register bits to control the pin mode function and data.

NuMicro™ NUC100/NUC120 Low Density has up to 65 General Purpose I/O pins can be shared with other function pins; it depends on the chip configuration and package. These 65 pins are arranged in 4 ports named with GPIOA, GPIOB, GPIOC and GPIOD with each port equips maximum 16 pins and another port named GPIOE with 1 pins PE.5.

The I/O type of each of I/O pins can be configured by software individually as input, output, open-drain or quasi-bidirectional mode. After reset, the I/O type of all pins stay in quasi-bidirectional mode and port data register GPIOx\_DOUT[15:0] resets to 0x0000\_FFFF. Each I/O pin equips a very weakly individual pull-up resistor which is about 110K $\Omega$ ~300K $\Omega$  for V<sub>DD</sub> is from 5.0 V to 2.5 V.

### 5.5.2 Features

- Four I/O modes:
  - ◆ Quasi bi-direction
  - ◆ Push-Pull output
  - ◆ Open-Drain output
  - ◆ Input only with high impedance
- TTL/Schmitt trigger input selectable
- I/O pin can be configured as interrupt source with edge/level setting
- High driver and high sink IO mode support

### 5.5.3 Function Description

#### 5.5.3.1 Input Mode Explanation

Set GPIOx\_PMD (PMDn[1:0]) to 00b the GPIOx port [n] pin is in Input mode and the I/O pin is in tri-state (high impedance) without output drive capability. The GPIOx\_PIN value reflects the status of the corresponding port pins.

#### 5.5.3.2 Output Mode Explanation

Set GPIOx\_PMD (PMDn[1:0]) to 01b the GPIOx port [n] pin is in Output mode and the I/O pin supports digital output function with source/sink current capability. The bit value in the corresponding bit [n] of GPIOx\_DOUT is driven on the pin.

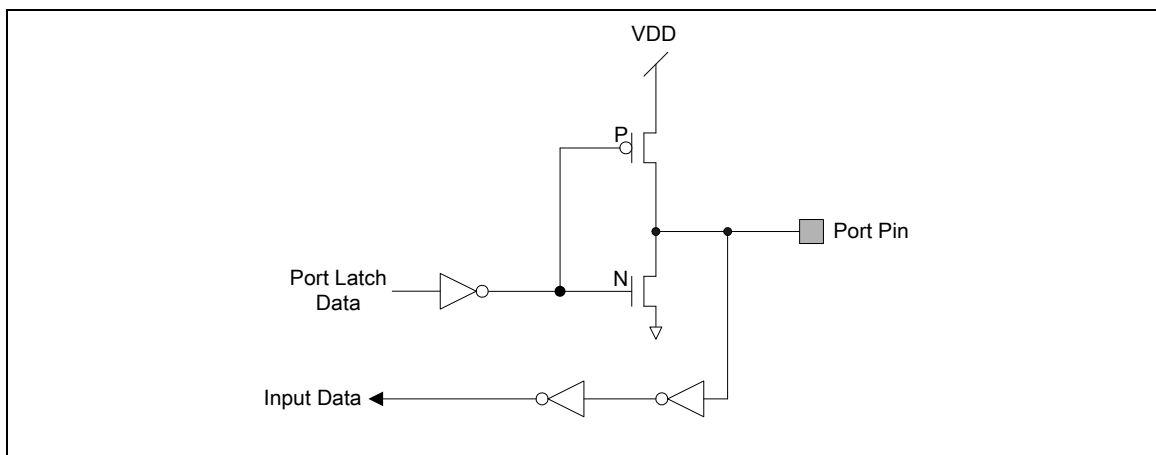

Figure 5-15 Push-Pull Output

### 5.5.3.3 Open-Drain Mode Explanation

Set GPIOx\_PMD (PMDn[1:0]) to 10b the GPIOx port [n] pin is in Open-Drain mode and the digital output function of I/O pin supports only sink current capability, an additional pull-up resistor is needed for driving high state. If the bit value in the corresponding bit [n] of GPIOx\_DOUT is 0, the pin drive a “low” output on the pin. If the bit value in the corresponding bit [n] of GPIOx\_DOUT is 1, the pin output drives high that is controlled by external pull high resistor.

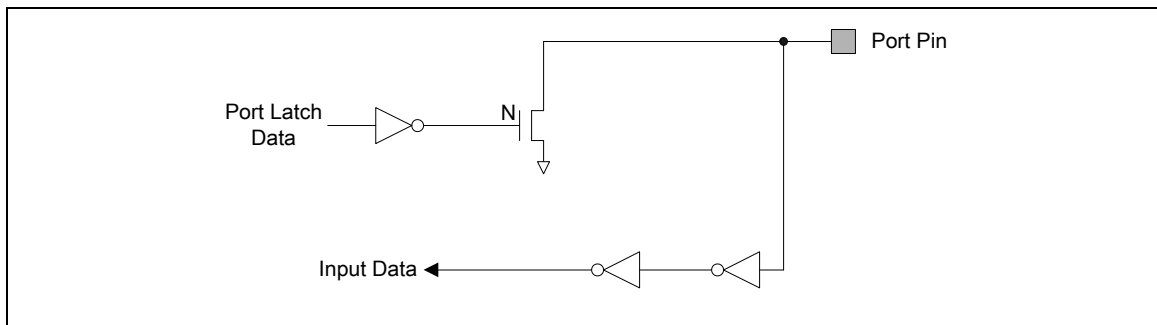

Figure 5-16 Open-Drain Output

### 5.5.3.4 Quasi-bidirectional Mode Explanation

Set GPIOx\_PMD (PMDn[1:0]) to 11b the GPIOx port [n] pin is in Quasi-bidirectional mode and the I/O pin supports digital output and input function at the same time but the source current is only up to hundreds uA. Before the digital input function is performed the corresponding bit in GPIOx\_DOUT must be set to 1. The quasi-bidirectional output is common on the 80C51 and most of its derivatives. If the bit value in the corresponding bit [n] of GPIOx\_DOUT is 0, the pin drive a “low” output on the pin. If the bit value in the corresponding bit [n] of GPIOx\_DOUT is 1, the pin will check the pin value. If pin value is high, no action takes. If pin state is low, then pin will drive strong high with 2 clock cycles on the pin and then disable the strong output drive and then the pin status is control by internal pull-up resistor. Note that the source current capability in quasi-bidirectional mode is only about 200 uA to 30 uA for V<sub>DD</sub> is form 5.0 V to 2.5 V.

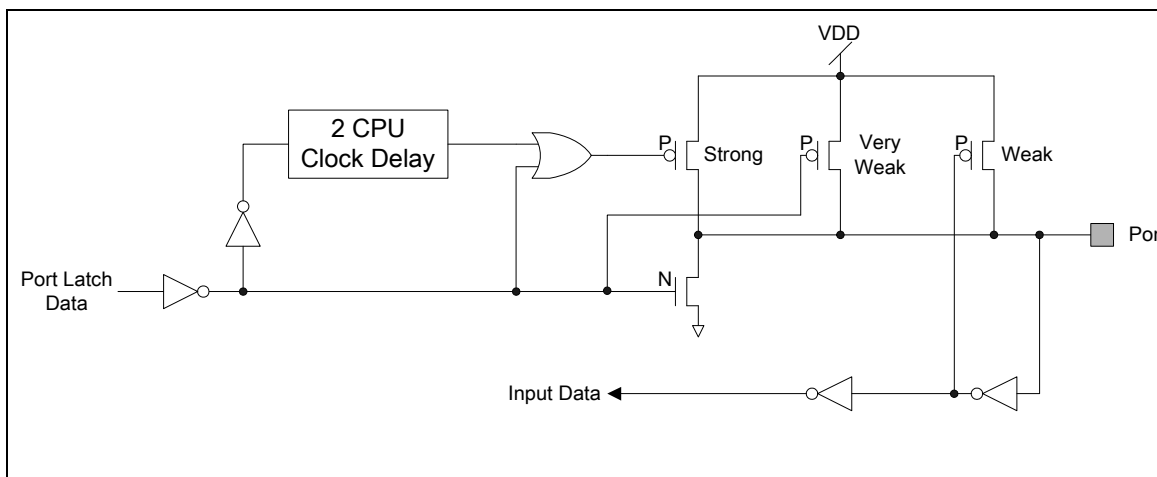

Figure 5-17 Quasi-bidirectional I/O Mode



### 5.5.3.5 GPIO Interrupt and wakeup function

Each GPIO pin can be set as chip interrupt source by setting correlative GPIOx\_IEN bit and GPIOx\_IMD. There are four types of interrupt condition can be selected: low level trigger, high level trigger, falling edge trigger and rising edge trigger. For edge trigger condition, user can enable input signal de-bounce function to prevent unexpected interrupt happened which caused by noise. The de-bounce clock source and sampling cycle can be set through DEBOUNCE register.

The GPIO can also be the chip wakeup source when chip enter idle mode or power down mode. The setting of wakeup trigger condition is the same as GPIO interrupt trigger, but there are two things need to be noticed if using GPIO as chip wakeup source

#### **1. To ensure the I/O status before enter into power down mode**

If using toggle GPIO to wakeup system, user must to make sure the I/O status before entering to idle mode or power down mode according to the relative wakeup settings.

For example, if configure the wakeup event occurred by I/O rising edge/high level trigger, user must make sure the I/O status of specified pin is at low level before entering to idle/power down mode; and if configure I/O falling edge/low level trigger to trigger a wakeup event, user must make sure the I/O status of specified pin is at high level before entering to power down mode.

#### **2. To disable the specified I/O de-bounce function if necessary**

If the specified wakeup GPIO with input signal de-bounce function, we must disable de-bounce function before system enter into power down mode, otherwise system will encounter two GPIO interrupts when system wakeup (One is cause by wakeup function, the other one is caused by de-bounce function).



## 5.5.4 Register Map

R: read only, W: write only, R/W: both read and write

Register	Offset	R/W	Description	Reset Value
<b>GP_BA = 0x5000_4000</b>				
<b>GPIOA_PMD</b>	GP_BA+0x000	R/W	GPIO Port A Pin I/O Mode Control	0xFFFF_FFFF
<b>GPIOA_OFFD</b>	GP_BA+0x004	R/W	GPIO Port A Pin Digital Input Path Disable Control	0x0000_0000
<b>GPIOA_DOUT</b>	GP_BA+0x008	R/W	GPIO Port A Data Output Value	0x0000_FFFF
<b>GPIOA_DMASK</b>	GP_BA+0x00C	R/W	GPIO Port A Data Output Write Mask	0x0000_0000
<b>GPIOA_PIN</b>	GP_BA+0x010	R	GPIO Port A Pin Value	0x0000_XXXX
<b>GPIOA_DBEN</b>	GP_BA+0x014	R/W	GPIO Port A De-bounce Enable	0x0000_0000
<b>GPIOA_IMD</b>	GP_BA+0x018	R/W	GPIO Port A Interrupt Mode Control	0x0000_0000
<b>GPIOA_IEN</b>	GP_BA+0x01C	R/W	GPIO Port A Interrupt Enable	0x0000_0000
<b>GPIOA_ISRC</b>	GP_BA+0x020	R/W	GPIO Port A Interrupt Source Flag	0XXXXX_XXXX
<b>GPIOB_PMD</b>	GP_BA+0x040	R/W	GPIO Port B Pin I/O Mode Control	0xFFFF_FFFF
<b>GPIOB_OFFD</b>	GP_BA+0x044	R/W	GPIO Port B Pin Digital Input Path Disable Control	0x0000_0000
<b>GPIOB_DOUT</b>	GP_BA+0x048	R/W	GPIO Port B Data Output Value	0x0000_FFFF
<b>GPIOB_DMASK</b>	GP_BA+0x04C	R/W	GPIO Port B Data Output Write Mask	0x0000_0000
<b>GPIOB_PIN</b>	GP_BA+0x050	R	GPIO Port B Pin Value	0x0000_XXXX
<b>GPIOB_DBEN</b>	GP_BA+0x054	R/W	GPIO Port B De-bounce Enable	0x0000_0000
<b>GPIOB_IMD</b>	GP_BA+0x058	R/W	GPIO Port B Interrupt Mode Control	0x0000_0000
<b>GPIOB_IEN</b>	GP_BA+0x05C	R/W	GPIO Port B Interrupt Enable	0x0000_0000
<b>GPIOB_ISRC</b>	GP_BA+0x060	R/W	GPIO Port B Interrupt Source Flag	0XXXXX_XXXX
<b>GPIOC_PMD</b>	GP_BA+0x080	R/W	GPIO Port C Pin I/O Mode Control	0xFFFF_FFFF
<b>GPIOC_OFFD</b>	GP_BA+0x084	R/W	GPIO Port C Pin Digital Input Path Disable Control	0x0000_0000
<b>GPIOC_DOUT</b>	GP_BA+0x088	R/W	GPIO Port C Data Output Value	0x0000_FFFF
<b>GPIOC_DMASK</b>	GP_BA+0x08C	R/W	GPIO Port C Data Output Write Mask	0x0000_0000
<b>GPIOC_PIN</b>	GP_BA+0x090	R	GPIO Port C Pin Value	0x0000_XXXX
<b>GPIOC_DBEN</b>	GP_BA+0x094	R/W	GPIO Port C De-bounce Enable	0x0000_0000
<b>GPIOC_IMD</b>	GP_BA+0x098	R/W	GPIO Port C Interrupt Mode Control	0x0000_0000



Register	Offset	R/W	Description	Reset Value
<b>GPIOC_IEN</b>	GP_BA+0x09C	R/W	GPIO Port C Interrupt Enable	0x0000_0000
<b>GPIOC_ISRC</b>	GP_BA+0x0A0	R/W	GPIO Port C Interrupt Source Flag	0xFFFF_FFFF
<b>GPIOD_PMD</b>	GP_BA+0x0C0	R/W	GPIO Port D Pin I/O Mode Control	0xFFFF_FFFF
<b>GPIOD_OFFD</b>	GP_BA+0x0C4	R/W	GPIO Port D Pin Digital Input Path Disable Control	0x0000_0000
<b>GPIOD_DOUT</b>	GP_BA+0x0C8	R/W	GPIO Port D Data Output Value	0x0000_FFFF
<b>GPIOD_DMASK</b>	GP_BA+0x0CC	R/W	GPIO Port D Data Output Write Mask	0x0000_0000
<b>GPIOD_PIN</b>	GP_BA+0x0D0	R	GPIO Port D Pin Value	0x0000_XXXX
<b>GPIOD_DBEN</b>	GP_BA+0x0D4	R/W	GPIO Port D De-bounce Enable	0x0000_0000
<b>GPIOD_IMD</b>	GP_BA+0x0D8	R/W	GPIO Port D Interrupt Mode Control	0x0000_0000
<b>GPIOD_IEN</b>	GP_BA+0x0DC	R/W	GPIO Port D Interrupt Enable	0x0000_0000
<b>GPIOD_ISRC</b>	GP_BA+0x0E0	R/W	GPIO Port D Interrupt Source Flag	0xFFFF_FFFF
<b>GPIOE_PMD</b>	GP_BA+0x100	R/W	GPIO Port E Pin I/O Mode Control	0xFFFF_FFFF
<b>GPIOE_OFFD</b>	GP_BA+0x104	R/W	GPIO Port E Pin Digital Input Path Disable Control	0x0000_0000
<b>GPIOE_DOUT</b>	GP_BA+0x108	R/W	GPIO Port E Data Output Value	0x0000_FFFF
<b>GPIOE_DMASK</b>	GP_BA+0x10C	R/W	GPIO Port E Data Output Write Mask	0x0000_0000
<b>GPIOE_PIN</b>	GP_BA+0x110	R	GPIO Port E Pin Value	0x0000_XXXX
<b>GPIOE_DBEN</b>	GP_BA+0x114	R/W	GPIO Port E De-bounce Enable	0x0000_0000
<b>GPIOE_IMD</b>	GP_BA+0x118	R/W	GPIO Port E Interrupt Mode Control	0x0000_0000
<b>GPIOE_IEN</b>	GP_BA+0x11C	R/W	GPIO Port E Interrupt Enable	0x0000_0000
<b>GPIOE_ISRC</b>	GP_BA+0x120	R/W	GPIO Port E Interrupt Source Flag	0xFFFF_FFFF
<b>DBNCECON</b>	GP_BA+0x180	R/W	De-bounce Cycle Control	0x0000_0020
<b>PA0_PDIO</b>	GP_BA+0x200	R/W	GPIO PA.0 Pin Data Input/Output (NuMicro™ NUC100/NUC120 Low Density Only)	0x0000_0001
<b>PA1_PDIO</b>	GP_BA+0x204	R/W	GPIO PA.1 Pin Data Input/Output (NuMicro™ NUC100/NUC120 Low Density Only)	0x0000_0001
<b>PA2_PDIO</b>	GP_BA+0x208	R/W	GPIO PA.2 Pin Data Input/Output (NuMicro™ NUC100/NUC120 Low Density Only)	0x0000_0001
<b>PA3_PDIO</b>	GP_BA+0x20C	R/W	GPIO PA.3 Pin Data Input/Output (NuMicro™ NUC100/NUC120 Low Density Only)	0x0000_0001
<b>PA4_PDIO</b>	GP_BA+0x210	R/W	GPIO PA.4 Pin Data Input/Output	0x0000_0001



Register	Offset	R/W	Description	Reset Value
			(NuMicro™ NUC100/NUC120 Low Density Only)	
<b>PA5_PDIO</b>	GP_BA+0x214	R/W	GPIO PA.5 Pin Data Input/Output (NuMicro™ NUC100/NUC120 Low Density Only)	0x0000_0001
<b>PA6_PDIO</b>	GP_BA+0x218	R/W	GPIO PA.6 Pin Data Input/Output (NuMicro™ NUC100/NUC120 Low Density Only)	0x0000_0001
<b>PA7_PDIO</b>	GP_BA+0x21C	R/W	GPIO PA.7 Pin Data Input/Output (NuMicro™ NUC100/NUC120 Low Density Only)	0x0000_0001
<b>PA8_PDIO</b>	GP_BA+0x220	R/W	GPIO PA.8 Pin Data Input/Output (NuMicro™ NUC100/NUC120 Low Density Only)	0x0000_0001
<b>PA9_PDIO</b>	GP_BA+0x224	R/W	GPIO PA.9 Pin Data Input/Output (NuMicro™ NUC100/NUC120 Low Density Only)	0x0000_0001
<b>PA10_PDIO</b>	GP_BA+0x228	R/W	GPIO PA.10 Pin Data Input/Output (NuMicro™ NUC100/NUC120 Low Density Only)	0x0000_0001
<b>PA11_PDIO</b>	GP_BA+0x22C	R/W	GPIO PA.11 Pin Data Input/Output (NuMicro™ NUC100/NUC120 Low Density Only)	0x0000_0001
<b>PA12_PDIO</b>	GP_BA+0x230	R/W	GPIO PA.12 Pin Data Input/Output (NuMicro™ NUC100/NUC120 Low Density Only)	0x0000_0001
<b>PA13_PDIO</b>	GP_BA+0x234	R/W	GPIO PA.13 Pin Data Input/Output (NuMicro™ NUC100/NUC120 Low Density Only)	0x0000_0001
<b>PA14_PDIO</b>	GP_BA+0x238	R/W	GPIO PA.14 Pin Data Input/Output (NuMicro™ NUC100/NUC120 Low Density Only)	0x0000_0001
<b>PA15_PDIO</b>	GP_BA+0x23C	R/W	GPIO PA.15 Pin Data Input/Output (NuMicro™ NUC100/NUC120 Low Density Only)	0x0000_0001
<b>PB0_PDIO</b>	GP_BA+0x240	R/W	GPIO PB.0 Pin Data Input/Output (NuMicro™ NUC100/NUC120 Low Density Only)	0x0000_0001
<b>PB1_PDIO</b>	GP_BA+0x244	R/W	GPIO PB.1 Pin Data Input/Output (NuMicro™ NUC100/NUC120 Low Density Only)	0x0000_0001
<b>PB2_PDIO</b>	GP_BA+0x248	R/W	GPIO PB.2 Pin Data Input/Output (NuMicro™ NUC100/NUC120 Low Density Only)	0x0000_0001
<b>PB3_PDIO</b>	GP_BA+0x24C	R/W	GPIO PB.3 Pin Data Input/Output (NuMicro™ NUC100/NUC120 Low Density Only)	0x0000_0001
<b>PB4_PDIO</b>	GP_BA+0x250	R/W	GPIO PB.4 Pin Data Input/Output (NuMicro™ NUC100/NUC120 Low Density Only)	0x0000_0001
<b>PB5_PDIO</b>	GP_BA+0x254	R/W	GPIO PB.5 Pin Data Input/Output (NuMicro™ NUC100/NUC120 Low Density Only)	0x0000_0001



Register	Offset	R/W	Description	Reset Value
<b>PB6_PDIO</b>	GP_BA+0x258	R/W	GPIO PB.6 Pin Data Input/Output (NuMicro™ NUC100/NUC120 Low Density Only)	0x0000_0001
<b>PB7_PDIO</b>	GP_BA+0x25C	R/W	GPIO PB.7 Pin Data Input/Output (NuMicro™ NUC100/NUC120 Low Density Only)	0x0000_0001
<b>PB8_PDIO</b>	GP_BA+0x260	R/W	GPIO PB.8 Pin Data Input/Output (NuMicro™ NUC100/NUC120 Low Density Only)	0x0000_0001
<b>PB9_PDIO</b>	GP_BA+0x264	R/W	GPIO PB.9 Pin Data Input/Output (NuMicro™ NUC100/NUC120 Low Density Only)	0x0000_0001
<b>PB10_PDIO</b>	GP_BA+0x268	R/W	GPIO PB.10 Pin Data Input/Output (NuMicro™ NUC100/NUC120 Low Density Only)	0x0000_0001
<b>PB11_PDIO</b>	GP_BA+0x26C	R/W	GPIO PB.11 Pin Data Input/Output (NuMicro™ NUC100/NUC120 Low Density Only)	0x0000_0001
<b>PB12_PDIO</b>	GP_BA+0x270	R/W	GPIO PB.12 Pin Data Input/Output (NuMicro™ NUC100/NUC120 Low Density Only)	0x0000_0001
<b>PB13_PDIO</b>	GP_BA+0x274	R/W	GPIO PB.13 Pin Data Input/Output (NuMicro™ NUC100/NUC120 Low Density Only)	0x0000_0001
<b>PB14_PDIO</b>	GP_BA+0x278	R/W	GPIO PB.14 Pin Data Input/Output (NuMicro™ NUC100/NUC120 Low Density Only)	0x0000_0001
<b>PB15_PDIO</b>	GP_BA+0x27C	R/W	GPIO PB.15 Pin Data Input/Output (NuMicro™ NUC100/NUC120 Low Density Only)	0x0000_0001
<b>PC0_PDIO</b>	GP_BA+0x280	R/W	GPIO PC.0 Pin Data Input/Output (NuMicro™ NUC100/NUC120 Low Density Only)	0x0000_0001
<b>PC1_PDIO</b>	GP_BA+0x284	R/W	GPIO PC.1 Pin Data Input/Output (NuMicro™ NUC100/NUC120 Low Density Only)	0x0000_0001
<b>PC2_PDIO</b>	GP_BA+0x288	R/W	GPIO PC.2 Pin Data Input/Output (NuMicro™ NUC100/NUC120 Low Density Only)	0x0000_0001
<b>PC3_PDIO</b>	GP_BA+0x28C	R/W	GPIO PC.3 Pin Data Input/Output (NuMicro™ NUC100/NUC120 Low Density Only)	0x0000_0001
<b>PC4_PDIO</b>	GP_BA+0x290	R/W	GPIO PC.4 Pin Data Input/Output (NuMicro™ NUC100/NUC120 Low Density Only)	0x0000_0001
<b>PC5_PDIO</b>	GP_BA+0x294	R/W	GPIO PC.5 Pin Data Input/Output (NuMicro™ NUC100/NUC120 Low Density Only)	0x0000_0001
<b>PC6_PDIO</b>	GP_BA+0x298	R/W	GPIO PC.6 Pin Data Input/Output (NuMicro™ NUC100/NUC120 Low Density Only)	0x0000_0001
<b>PC7_PDIO</b>	GP_BA+0x29C	R/W	GPIO PC.7 Pin Data Input/Output	0x0000_0001



Register	Offset	R/W	Description	Reset Value
			(NuMicro™ NUC100/NUC120 Low Density Only)	
<b>PC8_PDIO</b>	GP_BA+0x2A0	R/W	GPIO PC.8 Pin Data Input/Output (NuMicro™ NUC100/NUC120 Low Density Only)	0x0000_0001
<b>PC9_PDIO</b>	GP_BA+0x2A4	R/W	GPIO PC.9 Pin Data Input/Output (NuMicro™ NUC100/NUC120 Low Density Only)	0x0000_0001
<b>PC10_PDIO</b>	GP_BA+0x2A8	R/W	GPIO PC.10 Pin Data Input/Output (NuMicro™ NUC100/NUC120 Low Density Only)	0x0000_0001
<b>PC11_PDIO</b>	GP_BA+0x2AC	R/W	GPIO PC.11 Pin Data Input/Output (NuMicro™ NUC100/NUC120 Low Density Only)	0x0000_0001
<b>PC12_PDIO</b>	GP_BA+0x2B0	R/W	GPIO PC.12 Pin Data Input/Output (NuMicro™ NUC100/NUC120 Low Density Only)	0x0000_0001
<b>PC13_PDIO</b>	GP_BA+0x2B4	R/W	GPIO PC.13 Pin Data Input/Output (NuMicro™ NUC100/NUC120 Low Density Only)	0x0000_0001
<b>PC14_PDIO</b>	GP_BA+0x2B8	R/W	GPIO PC.14 Pin Data Input/Output (NuMicro™ NUC100/NUC120 Low Density Only)	0x0000_0001
<b>PC15_PDIO</b>	GP_BA+0x2BC	R/W	GPIO PC.15 Pin Data Input/Output (NuMicro™ NUC100/NUC120 Low Density Only)	0x0000_0001
<b>PD0_PDIO</b>	GP_BA+0x2C0	R/W	GPIO PD.0 Pin Data Input/Output (NuMicro™ NUC100/NUC120 Low Density Only)	0x0000_0001
<b>PD1_PDIO</b>	GP_BA+0x2C4	R/W	GPIO PD.1 Pin Data Input/Output (NuMicro™ NUC100/NUC120 Low Density Only)	0x0000_0001
<b>PD2_PDIO</b>	GP_BA+0x2C8	R/W	GPIO PD.2 Pin Data Input/Output (NuMicro™ NUC100/NUC120 Low Density Only)	0x0000_0001
<b>PD3_PDIO</b>	GP_BA+0x2CC	R/W	GPIO PD.3 Pin Data Input/Output (NuMicro™ NUC100/NUC120 Low Density Only)	0x0000_0001
<b>PD4_PDIO</b>	GP_BA+0x2D0	R/W	GPIO PD.4 Pin Data Input/Output (NuMicro™ NUC100/NUC120 Low Density Only)	0x0000_0001
<b>PD5_PDIO</b>	GP_BA+0x2D4	R/W	GPIO PD.5 Pin Data Input/Output (NuMicro™ NUC100/NUC120 Low Density Only)	0x0000_0001
<b>PD6_PDIO</b>	GP_BA+0x2D8	R/W	GPIO PD.6 Pin Data Input/Output (NuMicro™ NUC100/NUC120 Low Density Only)	0x0000_0001
<b>PD7_PDIO</b>	GP_BA+0x2DC	R/W	GPIO PD.7 Pin Data Input/Output (NuMicro™ NUC100/NUC120 Low Density Only)	0x0000_0001
<b>PD8_PDIO</b>	GP_BA+0x2E0	R/W	GPIO PD.8 Pin Data Input/Output (NuMicro™ NUC100/NUC120 Low Density Only)	0x0000_0001



Register	Offset	R/W	Description	Reset Value
<b>PD9_PDIO</b>	GP_BA+0x2E4	R/W	GPIO PD.9 Pin Data Input/Output (NuMicro™ NUC100/NUC120 Low Density Only)	0x0000_0001
<b>PD10_PDIO</b>	GP_BA+0x2E8	R/W	GPIO PD.10 Pin Data Input/Output (NuMicro™ NUC100/NUC120 Low Density Only)	0x0000_0001
<b>PD11_PDIO</b>	GP_BA+0x2EC	R/W	GPIO PD.11 Pin Data Input/Output (NuMicro™ NUC100/NUC120 Low Density Only)	0x0000_0001
<b>PD12_PDIO</b>	GP_BA+0x2F0	R/W	GPIO PD.12 Pin Data Input/Output (NuMicro™ NUC100/NUC120 Low Density Only)	0x0000_0001
<b>PD13_PDIO</b>	GP_BA+0x2F4	R/W	GPIO PD.13 Pin Data Input/Output (NuMicro™ NUC100/NUC120 Low Density Only)	0x0000_0001
<b>PD14_PDIO</b>	GP_BA+0x2F8	R/W	GPIO PD.14 Pin Data Input/Output (NuMicro™ NUC100/NUC120 Low Density Only)	0x0000_0001
<b>PD15_PDIO</b>	GP_BA+0x2FC	R/W	GPIO PD.15 Pin Data Input/Output (NuMicro™ NUC100/NUC120 Low Density Only)	0x0000_0001
<b>PE5_PDIO</b>	GP_BA+0x314	R/W	GPIO PE.5 Pin Data Input/Output (NuMicro™ NUC100/NUC120 Low Density Only)	0x0000_0001



### 5.5.5 Register Description

#### GPIO Port [A/B/C/D/E] I/O Mode Control (GPIOx PMD)

Register	Offset	R/W	Description	Reset Value
GPIOA_PMD	GP_BA+0x000	R/W	GPIO Port A Pin I/O Mode Control	0xFFFF_FFFF
GPIOB_PMD	GP_BA+0x040	R/W	GPIO Port B Pin I/O Mode Control	0xFFFF_FFFF
GPIOC_PMD	GP_BA+0x080	R/W	GPIO Port C Pin I/O Mode Control	0xFFFF_FFFF
GIOD_PMD	GP_BA+0x0C0	R/W	GPIO Port D Pin I/O Mode Control	0xFFFF_FFFF
GPIOE_PMD	GP_BA+0x100	R/W	GPIO Port E Pin I/O Mode Control	0xFFFF_FFFF

31	30	29	28	27	26	25	24
PMD15		PMD14		PMD13		PMD12	
23	22	21	20	19	18	17	16
PMD11		PMD10		PMD9		PMD8	
15	14	13	12	11	10	9	8
PMD7		PMD6		PMD5		PMD4	
7	6	5	4	3	2	1	0
PMD3		PMD2		PMD1		PMD0	

Bits	Descriptions	
[2n+1:2n]	PMDn	<p><b>GPIOx I/O Pin[n] Mode Control</b></p> <p>Determine each I/O type of GPIOx pins.</p> <p>00 = GPIO port [n] pin is in INPUT mode</p> <p>01 = GPIO port [n] pin is in OUTPUT mode</p> <p>10 = GPIO port [n] pin is in Open-Drain mode</p> <p>11 = GPIO port [n] pin is in Quasi-bidirectional mode</p>





**GPIO Port [A/B/C/D/E] Pin Digital Input Path Disable Control (GPIOx OFFD)**

Register	Offset	R/W	Description	Reset Value
GPIOA_OFFD	GP_BA+0x004	R/W	GPIO Port A Pin Digital Input Path Disable Control	0x0000_0000
GPIOB_OFFD	GP_BA+0x044	R/W	GPIO Port B Pin Digital Input Path Disable Control	0x0000_0000
GPIOC_OFFD	GP_BA+0x084	R/W	GPIO Port C Pin Digital Input Path Disable Control	0x0000_0000
GIOD_OFFD	GP_BA+0x0C4	R/W	GPIO Port D Pin Digital Input Path Disable Control	0x0000_0000
GPIOE_OFFD	GP_BA+0x104	R/W	GPIO Port E Pin Digital Input Path Disable Control	0x0000_0000

31	30	29	28	27	26	25	24
OFFD							
23	22	21	20	19	18	17	16
OFFD							
15	14	13	12	11	10	9	8
Reserved							
7	6	5	4	3	2	1	0
Reserved							

Bits	Descriptions	
[16:31]	OFFD	<p><b>GPIOx Pin[n] Digital Input Path Disable Control</b></p> <p>Each of these bits is used to control if the digital input path of corresponding GPIO pin is disabled. If input is analog signal, users can disable GPIO digital input path to avoid creepage</p> <p>1 = Disable IO digital input path (digital input tied to low)</p> <p>0 = Enable IO digital input path</p>
[0:15]	Reserved	Reserved



## GPIO Port [A/B/C/D/E] Data Output Value (GPIOx DOUT)

Register	Offset	R/W	Description	Reset Value
GPIOA_DOUT	GP_BA+0x008	R/W	GPIO Port A Data Output Value	0x0000_FFFF
GPIOB_DOUT	GP_BA+0x048	R/W	GPIO Port B Data Output Value	0x0000_FFFF
GPIOC_DOUT	GP_BA+0x088	R/W	GPIO Port C Data Output Value	0x0000_FFFF
GIPOD_DOUT	GP_BA+0x0C8	R/W	GPIO Port D Data Output Value	0x0000_FFFF
GPIOE_DOUT	GP_BA+0x108	R/W	GPIO Port E Data Output Value	0x0000_FFFF

31	30	29	28	27	26	25	24
Reserved							
23	22	21	20	19	18	17	16
Reserved							
15	14	13	12	11	10	9	8
DOUT[15:8]							
7	6	5	4	3	2	1	0
DOUT[7:0]							

Bits	Descriptions	
[31:16]	Reserved	Reserved
[n]	DOUT[n]	<p><b>GPIOx Pin[n] Output Value</b></p> <p>Each of these bits control the status of a GPIO pin when the GPIO pin is configured as output, open-drain and quasi-mode.</p> <p>1 = GPIO port [A/B/C/D/E] Pin[n] will drive High if the GPIO pin is configured as output, open-drain and quasi-mode.</p> <p>0 = GPIO port [A/B/C/D/E] Pin[n] will drive Low if the GPIO pin is configured as output, open-drain and quasi-mode.</p>



## GPIO Port [A/B/C/D/E] Data Output Write Mask (GPIOx\_DMASK)

Register	Offset	R/W	Description	Reset Value
GPIOA_DMASK	GP_BA+0x00C	R/W	GPIO Port A Data Output Write Mask	0xFFFF_0000
GPIOB_DMASK	GP_BA+0x04C	R/W	GPIO Port B Data Output Write Mask	0xFFFF_0000
GPIOC_DMASK	GP_BA+0x08C	R/W	GPIO Port C Data Output Write Mask	0xFFFF_0000
GIOD_DMASK	GP_BA+0x0CC	R/W	GPIO Port D Data Output Write Mask	0xFFFF_0000
GPIOE_DMASK	GP_BA+0x10C	R/W	GPIO Port E Data Output Write Mask	0xFFFF_0000

31	30	29	28	27	26	25	24
Reserved							
23	22	21	20	19	18	17	16
Reserved							
15	14	13	12	11	10	9	8
DMASK[15:8]							
7	6	5	4	3	2	1	0
DMASK[7:0]							

Bits	Descriptions	
[31:16]	Reserved	Reserved
[n]	DMASK[n]	<p><b>Port [A/B/C/D/E] Data Output Write Mask</b></p> <p>These bits are used to protect the corresponding register of GPIOx_DOUT bit[n]. When set the DMASK bit[n] to 1, the corresponding GPIOx_DOUT[n] bit is protected. The write signal is masked, write data to the protect bit is ignored</p> <p>1 = The corresponding GPIOx_DOUT[n] bit is protected 0 = The corresponding GPIOx_DOUT[n] bit can be updated</p> <p>Note: This function only protect corresponding GPIOx_DOUT[n] bit, and will not protect corresponding bit control register (GPIOAx_DOUT, GPIOBx_DOUT, GPIOCx_DOUT, GIODx_DOUT, GPIOEx_DOUT).</p>



### GPIO Port [A/B/C/D/E] Pin Value (GPIOx\_PIN)

Register	Offset	R/W	Description	Reset Value
GPIOA_PIN	GP_BA+0x010	R	GPIO Port A Pin Value	0x0000_XXXX
GPIOB_PIN	GP_BA+0x050	R	GPIO Port B Pin Value	0x0000_XXXX
GPIOC_PIN	GP_BA+0x090	R	GPIO Port C Pin Value	0x0000_XXXX
GIOD_PIN	GP_BA+0x0D0	R	GPIO Port D Pin Value	0x0000_XXXX
GPIOE_PIN	GP_BA+0x110	R	GPIO Port E Pin Value	0x0000_XXXX

31	30	29	28	27	26	25	24
Reserved							
23	22	21	20	19	18	17	16
Reserved							
15	14	13	12	11	10	9	8
PIN[15:8]							
7	6	5	4	3	2	1	0
PIN[7:0]							

Bits	Descriptions	
[31:16]	Reserved	Reserved
[n]	PIN[n]	<b>Port [A/B/C/D/E] Pin Values</b> Each bit of the register reflects the actual status of the respective GPIO pin. If bit is 1, it indicates the corresponding pin status is high, else the pin status is low.



## GPIO Port [A/B/C/D/E] De-bounce Enable (GPIOx\_DBEN)

Register	Offset	R/W	Description	Reset Value
GPIOA_DBEN	GP_BA+0x014	R/W	GPIO Port A De-bounce Enable	0xFFFF_0000
GPIOB_DBEN	GP_BA+0x054	R/W	GPIO Port B De-bounce Enable	0xFFFF_0000
GPIOC_DBEN	GP_BA+0x094	R/W	GPIO Port C De-bounce Enable	0xFFFF_0000
GIPOD_DBEN	GP_BA+0x0D4	R/W	GPIO Port D De-bounce Enable	0xFFFF_0000
GPIOE_DBEN	GP_BA+0x114	R/W	GPIO Port E De-bounce Enable	0xFFFF_0000

31	30	29	28	27	26	25	24
Reserved							
23	22	21	20	19	18	17	16
Reserved							
15	14	13	12	11	10	9	8
DBEN[15:8]							
7	6	5	4	3	2	1	0
DBEN[7:0]							

Bits	Descriptions	
[31:16]	Reserved	Reserved
[n]	DBEN[n]	<p><b>Port [A/B/C/D/E] Input Signal De-bounce Enable</b></p> <p>DBEN[n] used to enable the de-bounce function for each corresponding bit. If the input signal pulse width can't be sampled by continuous two de-bounce sample cycle. The input signal transition is seen as the signal bounce and will not trigger the interrupt. The de-bounce clock source is controlled by DBNCECON[4], one de-bounce sample cycle is controlled by DBNCECON[3:0]</p> <p>1 = The bit[n] de-bounce function is enabled 0 = The bit[n] de-bounce function is disabled</p> <p>The de-bounce function is valid for edge triggered interrupt. If the interrupt mode is level triggered, the de-bounce enable bit is ignored.</p> <p>Note: It is recommended setting this bit to '0' if GPIO is chosen as power down wakeup source. If set this bit to '1', will cause GPIO to produce interrupt twice. One is caused by wake up event, the other one is caused by delayed de-bounce result.</p>



### GPIO Port [A/B/C/D/E] Interrupt Mode Control (GPIOx IMD)

Register	Offset	R/W	Description	Reset Value
GPIOA_IMD	GP_BA+0x018	R/W	GPIO Port A Interrupt Mode Control	0xFFFF_0000
GPIOB_IMD	GP_BA+0x058	R/W	GPIO Port B Interrupt Mode Control	0xFFFF_0000
GPIOC_IMD	GP_BA+0x098	R/W	GPIO Port C Interrupt Mode Control	0xFFFF_0000
GIPOD_IMD	GP_BA+0x0D8	R/W	GPIO Port D Interrupt Mode Control	0xFFFF_0000
GPIOE_IMD	GP_BA+0x118	R/W	GPIO Port E Interrupt Mode Control	0xFFFF_0000

31	30	29	28	27	26	25	24
Reserved							
23	22	21	20	19	18	17	16
Reserved							
15	14	13	12	11	10	9	8
IMD[15:8]							
7	6	5	4	3	2	1	0
IMD[7:0]							

Bits	Descriptions	
[31:16]	<b>Reserved</b>	Reserved
[n]	<b>IMD[n]</b>	<p><b>Port [A/B/C/D/E] Edge or Level Detection Interrupt Control</b></p> <p>IMD[n] is used to control the interrupt is by level trigger or by edge trigger. If the interrupt is by edge trigger, the trigger source can be controlled by de-bounce. If the interrupt is by level trigger, the input source is sampled by one HCLK clock and generates the interrupt.</p> <p>1 = Level trigger interrupt 0 = Edge trigger interrupt</p> <p>If set pin as the level trigger interrupt, then only one level can be set on the registers GPIOx_IEN. If set both the level to trigger interrupt, the setting is ignored and no interrupt will occur</p> <p>The de-bounce function is valid for edge triggered interrupt. If the interrupt mode is level triggered, the de-bounce enable bit is ignored.</p>



## GPIO Port [A/B/C/D] Interrupt Enable Control (GPIOx\_IEN)

Register	Offset	R/W	Description	Reset Value
GPIOA_IEN	GP_BA+0x01C	R/W	GPIO Port A Interrupt Enable	0x0000_0000
GPIOB_IEN	GP_BA+0x05C	R/W	GPIO Port B Interrupt Enable	0x0000_0000
GPIOC_IEN	GP_BA+0x09C	R/W	GPIO Port C Interrupt Enable	0x0000_0000
GIPOD_IEN	GP_BA+0x0DC	R/W	GPIO Port D Interrupt Enable	0x0000_0000
GPIOE_IEN	GP_BA+0x11C	R/W	GPIO Port E Interrupt Enable	0x0000_0000

31	30	29	28	27	26	25	24
IR_EN[15:8]							
23	22	21	20	19	18	17	16
IR_EN[7:0]							
15	14	13	12	11	10	9	8
IF_EN[15:8]							
7	6	5	4	3	2	1	0
IF_EN[7:0]							

Bits	Descriptions
[n+16]	<p><b>Port [A/B/C/D/E] Interrupt Enable by Input Rising Edge or Input Level High</b></p> <p>IR_EN[n] used to enable the interrupt for each of the corresponding input GPIO_PIN[n]. Set bit to 1 also enable the pin wake-up function</p> <p>When set the IR_EN[n] bit to 1:</p> <p>If the interrupt is level trigger, the input PIN[n] state at level "high" will generate the interrupt.</p> <p>If the interrupt is edge trigger, the input PIN[n] state change from "low-to-high" will generate the interrupt.</p> <p>1 = Enable the PIN[n] level-high or low-to-high interrupt 0 = Disable the PIN[n] level-high or low-to-high interrupt</p>
[n]	<p><b>Port [A/B/C/D/E] Interrupt Enable by Input Falling Edge or Input Level Low</b></p> <p>IF_EN[n] used to enable the interrupt for each of the corresponding input GPIO_PIN[n]. Set bit to 1 also enable the pin wake-up function</p> <p>When set the IF_EN[n] bit to 1:</p> <p>If the interrupt is level trigger, the input PIN[n] state at level "low" will generate the interrupt.</p> <p>If the interrupt is edge trigger, the input PIN[n] state change from "high-to-low" will generate the interrupt.</p> <p>1 = Enable the PIN[n] state low-level or high-to-low change interrupt 0 = Disable the PIN[n] state low-level or high-to-low change interrupt</p>



## GPIO Port [A/B/C/D/E] Interrupt Source Flag (GPIOx\_ISRC)

Register	Offset	R/W	Description	Reset Value
GPIOA_ISRC	GP_BA+0x020	R/W	GPIO Port A Interrupt Source Flag	0x0000_0000
GPIOB_ISRC	GP_BA+0x060	R/W	GPIO Port B Interrupt Source Flag	0x0000_0000
GPIOC_ISRC	GP_BA+0x0A0	R/W	GPIO Port C Interrupt Source Flag	0x0000_0000
GPIOD_ISRC	GP_BA+0x0E0	R/W	GPIO Port D Interrupt Source Flag	0x0000_0000
GPIOE_ISRC	GP_BA+0x120	R/W	GPIO Port E Interrupt Source Flag	0x0000_0000

31	30	29	28	27	26	25	24
Reserved							
23	22	21	20	19	18	17	16
Reserved							
15	14	13	12	11	10	9	8
ISRC[15:8]							
7	6	5	4	3	2	1	0
ISRC[7:0]							

Bits	Descriptions	
[31:16]	<b>Reserved</b>	Reserved
[n]	<b>ISRC[n]</b>	<p><b>Port [A/B/C/D/E] Interrupt Source Flag</b></p> <p>Read :</p> <p>1 = Indicates GPIOx[n] generate an interrupt</p> <p>0 = No interrupt at GPIOx[n]</p> <p>Write :</p> <p>1= Clear the correspond pending interrupt</p> <p>0= No action</p>





**Interrupt De-bounce Cycle Control (DBNCECON)**

Register	Offset	R/W	Description	Reset Value
DBNCECON	GP_BA+0x180	R/W	External Interrupt De-bounce Control	0x0000_0020

31	30	29	28	27	26	25	24
Reserved							
23	22	21	20	19	18	17	16
Reserved							
15	14	13	12	11	10	9	8
Reserved							
7	6	5	4	3	2	1	0
Reserved		ICLK_ON	DBCLKSRC	DBCLKSEL			

Bits	Descriptions																							
[5]	ICLK_ON	<p><b>Interrupt clock On mode</b></p> <p>1 = All IO pins edge detection circuit is always active after reset.</p> <p>0 = Edge detection circuit is active only if IO pin corresponding GPIOx_IEN bit is set to 1.</p> <p>It is recommended to turn off this bit to save system power, if on special application concern.</p>																						
[4]	DBCLKSRC	<p><b>De-bounce counter clock source select</b></p> <p>1 = De-bounce counter clock source is the internal 10 kHz low speed oscillator</p> <p>0 = De-bounce counter clock source is the HCLK</p>																						
[3:0]	DBCLKSEL	<p><b>De-bounce sampling cycle selection</b></p> <table border="1" style="width: 100%;"> <thead> <tr> <th>DBCLKSEL</th> <th>Description</th> </tr> </thead> <tbody> <tr> <td>0</td> <td>Sample interrupt input once per 1 clocks</td> </tr> <tr> <td>1</td> <td>Sample interrupt input once per 2 clocks</td> </tr> <tr> <td>2</td> <td>Sample interrupt input once per 4 clocks</td> </tr> <tr> <td>3</td> <td>Sample interrupt input once per 8 clocks</td> </tr> <tr> <td>4</td> <td>Sample interrupt input once per 16 clocks</td> </tr> <tr> <td>5</td> <td>Sample interrupt input once per 32 clocks</td> </tr> <tr> <td>6</td> <td>Sample interrupt input once per 64 clocks</td> </tr> <tr> <td>7</td> <td>Sample interrupt input once per 128 clocks</td> </tr> <tr> <td>8</td> <td>Sample interrupt input once per 256 clocks</td> </tr> <tr> <td>9</td> <td>Sample interrupt input once per 2*256 clocks</td> </tr> </tbody> </table>	DBCLKSEL	Description	0	Sample interrupt input once per 1 clocks	1	Sample interrupt input once per 2 clocks	2	Sample interrupt input once per 4 clocks	3	Sample interrupt input once per 8 clocks	4	Sample interrupt input once per 16 clocks	5	Sample interrupt input once per 32 clocks	6	Sample interrupt input once per 64 clocks	7	Sample interrupt input once per 128 clocks	8	Sample interrupt input once per 256 clocks	9	Sample interrupt input once per 2*256 clocks
DBCLKSEL	Description																							
0	Sample interrupt input once per 1 clocks																							
1	Sample interrupt input once per 2 clocks																							
2	Sample interrupt input once per 4 clocks																							
3	Sample interrupt input once per 8 clocks																							
4	Sample interrupt input once per 16 clocks																							
5	Sample interrupt input once per 32 clocks																							
6	Sample interrupt input once per 64 clocks																							
7	Sample interrupt input once per 128 clocks																							
8	Sample interrupt input once per 256 clocks																							
9	Sample interrupt input once per 2*256 clocks																							



Bits	Descriptions	
		10 Sample interrupt input once per 4*256clocks
		11 Sample interrupt input once per 8*256 clocks
		12 Sample interrupt input once per 16*256 clocks
		13 Sample interrupt input once per 32*256 clocks
		14 Sample interrupt input once per 64*256 clocks
		15 Sample interrupt input once per 128*256 clocks



## GPIO Px.n Pin Data Input/Output (Pxn\_PDIO)

Register	Offset	R/W	Description	Reset Value
<b>PAn_PDIO</b>	GP_BA+0x200 - GP_BA+0x23C	R/W	GPIO PA.n Pin Data Input/Output (NuMicro™ NUC100/NUC120 Low Density Only)	0x0000_0001
<b>PBn_PDIO</b>	GP_BA+0x240 - GP_BA+0x27C	R/W	GPIO PB.n Pin Data Input/Output (NuMicro™ NUC100/NUC120 Low Density Only)	0x0000_0001
<b>PCn_PDIO</b>	GP_BA+0x280 - GP_BA+0x2BC	R/W	GPIO PC.n Pin Data Input/Output (NuMicro™ NUC100/NUC120 Low Density Only)	0x0000_0001
<b>PDn_PDIO</b>	GP_BA+0x2C0 - GP_BA+0x2FC	R/W	GPIO PD.n Pin Data Input/Output (NuMicro™ NUC100/NUC120 Low Density Only)	0x0000_0001
<b>PE5_PDIO</b>	GP_BA+0x314	R/W	GPIO PE.5 Pin Data Input/Output (NuMicro™ NUC100/NUC120 Low Density Only)	0x0000_0001

Note: x = A/B/C/D/E and n = 0~15

31	30	29	28	27	26	25	24
Reserved							
23	22	21	20	19	18	17	16
Reserved							
15	14	13	12	11	10	9	8
Reserved							
7	6	5	4	3	2	1	0
Reserved							Pxn_PDIO

Bits	Descriptions
[0]	<p><b>Pxn_PDIO</b></p> <p><b>GPIO Px.n Pin Data Input/Output</b></p> <p>Write this bit can control one GPIO pin output value</p> <p>1 = Set corresponding GPIO pin to high</p> <p>0 = Set corresponding GPIO pin to low</p> <p>Read this register to get GPIO pin status.</p> <p>For example: write PA0_PDIO will reflect the written value to bit GPIOA_DOUT[0], read PA0_PDIO will return the value of GPIOA_PIN[0]</p> <p>Note: The write operation will not be affected by register GPIOx_DMASK</p>



## 5.6 I<sup>2</sup>C Serial Interface Controller (Master/Slave) (I<sup>2</sup>C)

### 5.6.1 Overview

I<sup>2</sup>C is a two-wire, bi-directional serial bus that provides a simple and efficient method of data exchange between devices. The I<sup>2</sup>C standard is a true multi-master bus including collision detection and arbitration that prevents data corruption if two or more masters attempt to control the bus simultaneously.

Data is transferred between a Master and a Slave synchronously to SCL on the SDA line on a byte-by-byte basis. Each data byte is 8-bit long. There is one SCL clock pulse for each data bit with the MSB being transmitted first. An acknowledge bit follows each transferred byte. Each bit is sampled during the high period of SCL; therefore, the SDA line may be changed only during the low period of SCL and must be held stable during the high period of SCL. A transition on the SDA line while SCL is high is interpreted as a command (START or STOP). Please refer to the Figure 5-18 for more detail I<sup>2</sup>C BUS Timing.

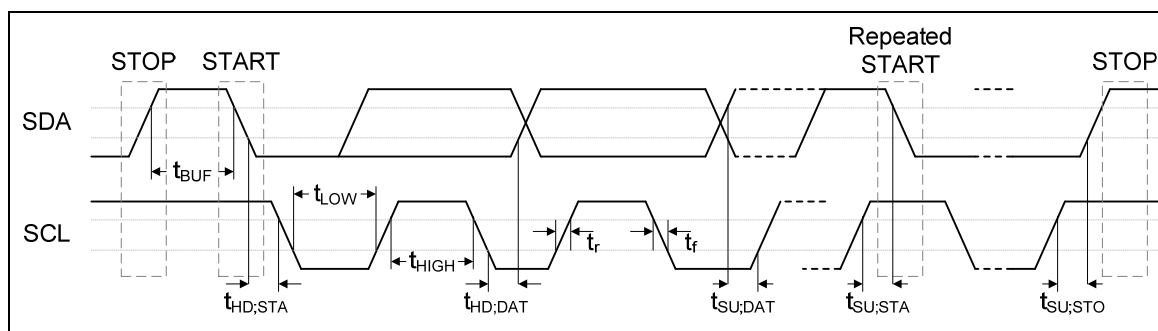

Figure 5-18 I<sup>2</sup>C Bus Timing

The device's on-chip I<sup>2</sup>C logic provides the serial interface that meets the I<sup>2</sup>C bus standard mode specification. The I<sup>2</sup>C port handles byte transfers autonomously. To enable this port, the bit ENS1 in I2CON should be set to '1'. The I<sup>2</sup>C H/W interfaces to the I<sup>2</sup>C bus via two pins: SDA and SCL. Pull up resistor is needed for I<sup>2</sup>C operation as these are open drain pins. When the I/O pins are used as I<sup>2</sup>C port, user must set the pins function to I<sup>2</sup>C in advance.

## 5.6.2 Features

The I<sup>2</sup>C bus uses two wires (SDA and SCL) to transfer information between devices connected to the bus. The main features of the bus are:

- Master/Slave mode
- Bidirectional data transfer between masters and slaves
- Multi-master bus (no central master)
- Arbitration between simultaneously transmitting masters without corruption of serial data on the bus
- Serial clock synchronization allows devices with different bit rates to communicate via one serial bus
- Serial clock synchronization can be used as a handshake mechanism to suspend and resume serial transfer
- Built-in a 14-bit time-out counter will request the I<sup>2</sup>C interrupt if the I<sup>2</sup>C bus hangs up and timer-out counter overflows.
- External pull-up are needed for high output
- Programmable clocks allow versatile rate control
- Supports 7-bit addressing mode
- I<sup>2</sup>C-bus controllers support multiple address recognition ( Four slave address with mask option)

### 5.6.3 Function Description

#### 5.6.3.1 I<sup>2</sup>C Protocol

Normally, a standard communication consists of four parts:

- 1) START or Repeated START signal generation
- 2) Slave address and R/W bit transfer
- 3) Data transfer
- 4) STOP signal generation

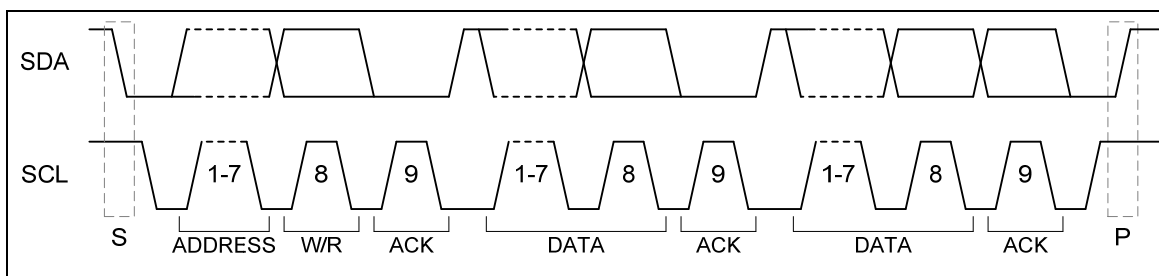

Figure 5-19 I<sup>2</sup>C Protocol

#### 5.6.3.2 Data transfer on the I<sup>2</sup>C-bus

Figure 5-20 shows a master transmits data to slave. A master addresses a slave with a 7-bit address and 1-bit write index to denote master wants to transmit data to slave. The master keep transmitting data after slave returns acknowledge to master.

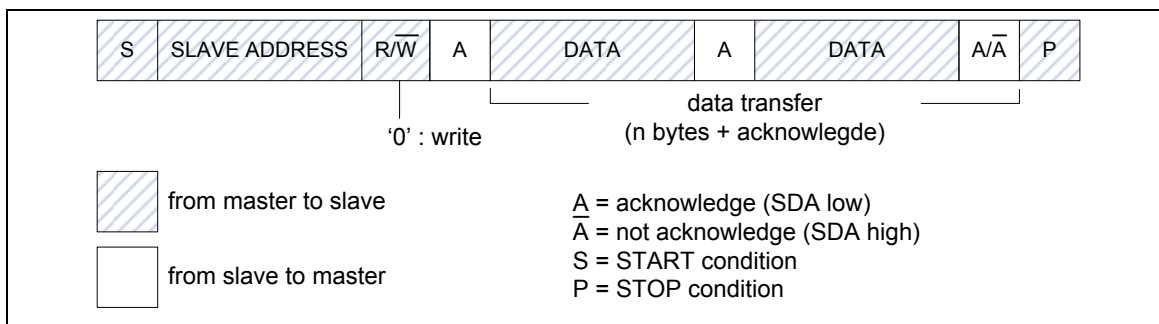

Figure 5-20 Master Transmits Data to Slave

Figure 5-21 shows a master read data from slave. A master addresses a slave with a 7-bit address and 1-bit read index to denote master wants to read data from slave. The slave will start transmitting data after slave returns acknowledge to master.

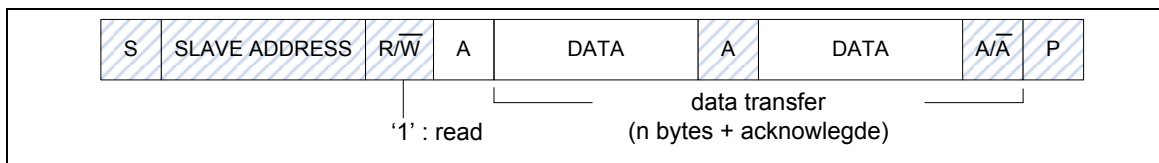

Figure 5-21 Master Reads Data from Slave

### 5.6.3.3 START or Repeated START signal

When the bus is free/idle, meaning no master device is engaging the bus (both SCL and SDA lines are high), a master can initiate a transfer by sending a START signal. A START signal, usually referred to as the S-bit, is defined as a HIGH to LOW transition on the SDA line while SCL is HIGH. The START signal denotes the beginning of a new data transfer.

A Repeated START (Sr) is no STOP signal between two START signals. The master uses this method to communicate with another slave or the same slave in a different transfer direction (e.g. from writing to a device to reading from a device) without releasing the bus.

#### STOP signal

The master can terminate the communication by generating a STOP signal. A STOP signal, usually referred to as the P-bit, is defined as a LOW to HIGH transition on the SDA line while SCL is HIGH.

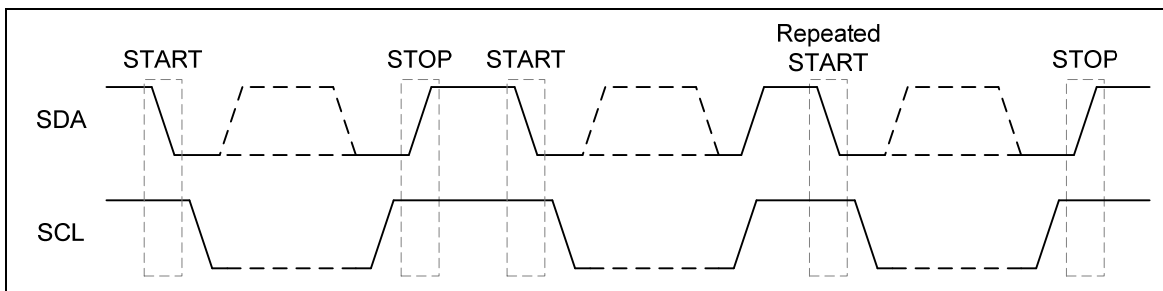

Figure 5-22 START and STOP condition

### 5.6.3.4 Slave Address Transfer

The first byte of data transferred by the master immediately after the START signal is the slave address. This is a 7-bit calling address followed by a RW bit. The RW bit signals the slave the data transfer direction. No two slaves in the system can have the same address. Only the slave with an address that matches the one transmitted by the master will respond by returning an acknowledge bit by pulling the SDA low at the 9th SCL clock cycle.

### 5.6.3.5 Data Transfer

Once successful slave addressing has been achieved, the data transfer can proceed on a byte-by-byte basis in the direction specified by the RW bit sent by the master. Each transferred byte is followed by an acknowledge bit on the 9th SCL clock cycle. If the slave signals a Not Acknowledge (NACK), the master can generate a STOP signal to abort the data transfer or generate a Repeated START signal and start a new transfer cycle.

If the master, as the receiving device, does Not Acknowledge (NACK) the slave, the slave releases the SDA line for the master to generate a STOP or Repeated START signal.



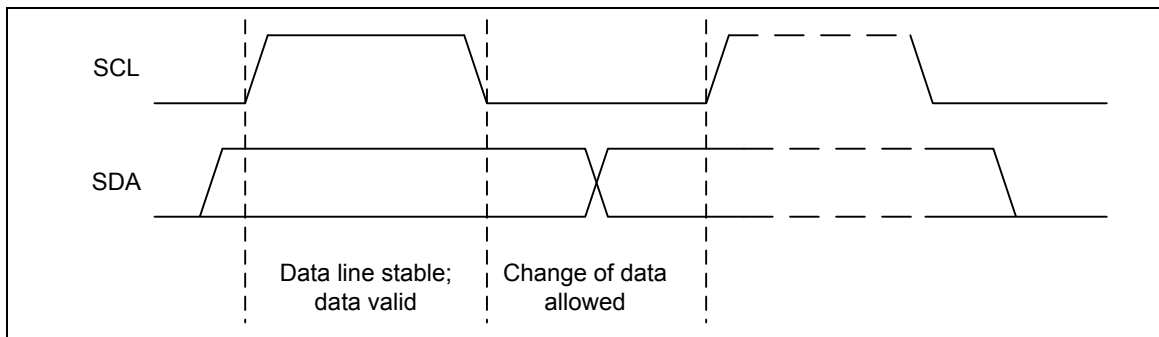

Figure 5-23 Bit Transfer on the I<sup>2</sup>C bus

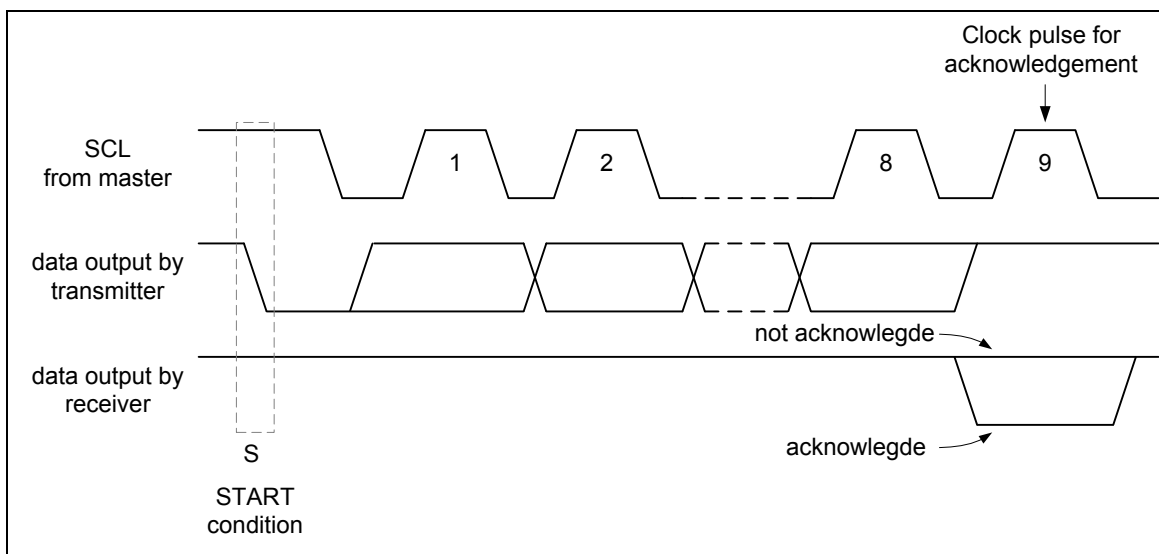

Figure 5-24 Acknowledge on the I<sup>2</sup>C bus

#### 5.6.4 Protocol Registers

The CPU interfaces to the I<sup>2</sup>C port through the following thirteen special function registers: I2CON (control register), I2CSTATUS (status register), I2CDAT (data register), I2CADDRn (address registers, n=0~3), I2CADMn (address mask registers, n=0~3), I2CLK (clock rate register) and I2CTOC (Time-out counter register). All bit 31~ bit 8 of these I<sup>2</sup>C special function registers are reserved. These bits do not have any functions and are all zero if read back.

When I<sup>2</sup>C port is enabled by setting ENS1 (I2CON [6]) to high, the internal states will be controlled by I2CON and I<sup>2</sup>C logic hardware. Once a new status code is generated and stored in I2CSTATUS, the I<sup>2</sup>C Interrupt Flag bit SI (I2CON [3]) will be set automatically. If the Enable Interrupt bit EI (I2CON [7]) is set high at this time, the I<sup>2</sup>C interrupt will be generated. The bit field I2CSTATUS[7:3] stores the internal state code, the lowest 3 bits of I2CSTATUS are always zero and the content keeps stable until SI is cleared by software. The base address is 4002\_0000 and 4012\_0000.

##### 5.6.4.1 Address Registers (I2CADDR)

I<sup>2</sup>C port is equipped with four slave address registers I2CADDRn (n=0~3). The contents of the register are irrelevant when I<sup>2</sup>C is in master mode. In the slave mode, the bit field I2CADDRn[7:1] must be loaded with the chip's own slave address. The I<sup>2</sup>C hardware will react if the contents of I2CADDRn are matched with the received slave address.

The I<sup>2</sup>C ports support the "General Call" function. If the GC bit (I2CADDRn [0]) is set the I<sup>2</sup>C port hardware will respond to General Call address (00H). Clear GC bit to disable general call function.

When GC bit is set and the I<sup>2</sup>C is in Slave mode, it can receive the general call address by 00H after Master send general call address to I<sup>2</sup>C bus, then it will follow status of GC mode.

I<sup>2</sup>C bus controllers support multiple address recognition with four address mask registers I2CADMn (n=0~3). When the bit in the address mask register is set to one, it means the received corresponding address bit is don't-care. If the bit is set to zero, that means the received corresponding register bit should be exact the same as address register.

#### 5.6.4.2 Data Register (I2CDAT)

This register contains a byte of serial data to be transmitted or a byte which just has been received. The CPU can read from or write to this 8-bit (I2CDAT [7:0]) directly while it is not in the process of shifting a byte. When I<sup>2</sup>C is in a defined state and the serial interrupt flag (SI) is set. Data in I2CDAT [7:0] remains stable as long as SI bit is set. While data is being shifted out, data on the bus is simultaneously being shifted in; I2CDAT [7:0] always contains the last data byte present on the bus. Thus, in the event of arbitration lost, the transition from master transmitter to slave receiver is made with the correct data in I2CDAT [7:0].

I2CDAT [7:0] and the acknowledge bit form a 9-bit shift register, the acknowledge bit is controlled by the I<sup>2</sup>C hardware and cannot be accessed by the CPU. Serial data is shifted through the acknowledge bit into I2CDAT [7:0] on the rising edges of serial clock pulses on the SCL line. When a byte has been shifted into I2CDAT [7:0], the serial data is available in I2CDAT [7:0], and the acknowledge bit (ACK or NACK) is returned by the control logic during the ninth clock pulse. Serial data is shifted out from I2CDAT [7:0] on the falling edges of SCL clock pulses, and is shifted into I2CDAT [7:0] on the rising edges of SCL clock pulses.

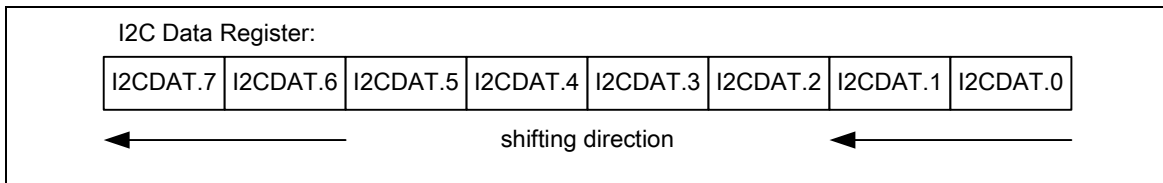

Figure 5-25 I<sup>2</sup>C Data Shifting Direction

#### 5.6.4.3 Control Register (I2CON)

The CPU can read from and write to this 8-bit field of I2CON [7:0] directly. Two bits are affected by hardware: the SI bit is set when the I<sup>2</sup>C hardware requests a serial interrupt, and the STO bit is cleared when a STOP condition is present on the bus. The STO bit is also cleared when ENS1 = 0.

- EI     Enable Interrupt.
- ENS1   Set to enable I<sup>2</sup>C serial function controller. When ENS1=1 the I<sup>2</sup>C serial function enables. The Multi Function pin function of SDA and SCL must be set to I<sup>2</sup>C function.
- STA    I<sup>2</sup>C START Control Bit. Setting STA to logic 1 to enter master mode, the I<sup>2</sup>C hardware sends a START or repeat START condition to bus when the bus is free.
- STO    I<sup>2</sup>C STOP Control Bit. In master mode, setting STO to transmit a STOP condition to bus then I<sup>2</sup>C hardware will check the bus condition if a STOP condition is detected this flag will be cleared by hardware automatically. In a slave mode, setting STO resets I<sup>2</sup>C hardware to the defined "not addressed" slave mode. This means it is NO LONGER in the slave receiver mode to receive data from the master transmit device.
- SI     I<sup>2</sup>C Interrupt Flag. When a new I<sup>2</sup>C state is present in the I2CSTATUS register, the SI flag is set by hardware, and if bit EI (I2CON [7]) is set, the I<sup>2</sup>C interrupt is requested. SI must be cleared by software. Clear SI is by writing 1 to this bit. All states are listed in section 5.6.6
- AA     Assert Acknowledge Control Bit. When AA=1 prior to address or data received, an acknowledged (low level to SDA) will be returned during the acknowledge clock pulse on the SCL line when 1.) A slave is acknowledging the address sent from master, 2.) The receiver devices are acknowledging the data sent by transmitter. When AA=0 prior to



address or data received, a Not acknowledged (high level to SDA) will be returned during the acknowledge clock pulse on the SCL line.

#### 5.6.4.4 Status Register (I2CSTATUS)

I2CSTATUS [7:0] is an 8-bit read-only register. The three least significant bits are always 0. The bit field I2CSTATUS [7:3] contain the status code. There are 26 possible status codes, All states are listed in section 5.6.6. When I2CSTATUS [7:0] contains F8H, no serial interrupt is requested. All other I2CSTATUS [7:3] values correspond to defined I<sup>2</sup>C states. When each of these states is entered, a status interrupt is requested (SI = 1). A valid status code is present in I2CSTATUS[7:3] one cycle after SI is set by hardware and is still present one cycle after SI has been reset by software.

In addition, state 00H stands for a Bus Error. A Bus Error occurs when a START or STOP condition is present at an illegal position in the format frame. Examples of illegal positions are during the serial transfer of an address byte, a data byte or an acknowledge bit. To recover I<sup>2</sup>C from bus error, STO should be set and SI should be clear to enter not addressed slave mode. Then clear STO to release bus and to wait new communication. I<sup>2</sup>C bus can not recognize stop condition during this action when bus error occurs.

Master mode		Slave Mode	
STATUS	Description	STATUS	Description
0x08	Start	0xA0	Slave Transmit Repeat Start or Stop
0x10	Master Repeat Start	0xA8	Slave Transmit Address ACK
0x18	Master Transmit Address ACK	0xB0	Slave Transmit Arbitration Lost
0x20	Master Transmit Address NACK	0xB8	Slave Transmit Data ACK
0x28	Master Transmit Data ACK	0xC0	Slave Transmit Data NACK
0x30	Master Transmit Data NACK	0xC8	Slave Transmit Last Data ACK
0x38	Master Arbitration Lost	0x60	Slave Receive Address ACK
0x40	Master Receive ACK	0x68	Slave Receive Arbitration Lost
0x48	Master Receive NACK	0x80	Slave Receive Data ACK
0x50	Master Receive ACK	0x88	Slave Receive Data NACK
0x58	Master Receive NACK	0x70	GC mode Address ACK
0x00	Bus error	0x78	GC mode Arbitration Lost
		0x90	GC mode Data ACK
		0x98	GC mode Data NACK
0xF8	Bus Released Note: Status "0xF8" exists in both master/slave modes, and it won't raise interrupt.		

Table 5-6 I<sup>2</sup>C Status Code Description Table

5.6.4.5 I<sup>2</sup>C Clock Baud Rate Bits (I2CLK)

The data baud rate of I<sup>2</sup>C is determined by I2CLK [7:0] register when I<sup>2</sup>C is in a master mode. It is not important when I<sup>2</sup>C is in a slave mode. In the slave modes, I<sup>2</sup>C will automatically synchronize with any clock frequency from master I<sup>2</sup>C device.

The data baud rate of I<sup>2</sup>C setting is Data Baud Rate of I<sup>2</sup>C = (system clock) / (4x (I2CLK [7:0] + 1)). If system clock = 16 MHz, the I2CLK [7:0] = 40 (28H), so data baud rate of I<sup>2</sup>C = 16 MHz / (4x (40 + 1)) = 97.5 Kbits/sec.

5.6.4.6 The I<sup>2</sup>C Time-out Counter Register (I2CTOC)

There is a 14-bit time-out counter which can be used to deal with the I<sup>2</sup>C bus hang-up. If the time-out counter is enabled, the counter starts up counting until it overflows (TIF=1) and generates I<sup>2</sup>C interrupt to CPU or stops counting by clearing ENTI to 0. When time-out counter is enabled, setting flag SI to high will reset counter and re-start up counting after SI is cleared. If I<sup>2</sup>C bus hangs up, it causes the I2CSTATUS and flag SI are not updated for a period, the 14-bit time-out counter may overflow and acknowledge CPU the I<sup>2</sup>C interrupt. Refer to the Figure 5-26 for the 14-bit time-out counter. User may write 1 to clear TIF to zero.

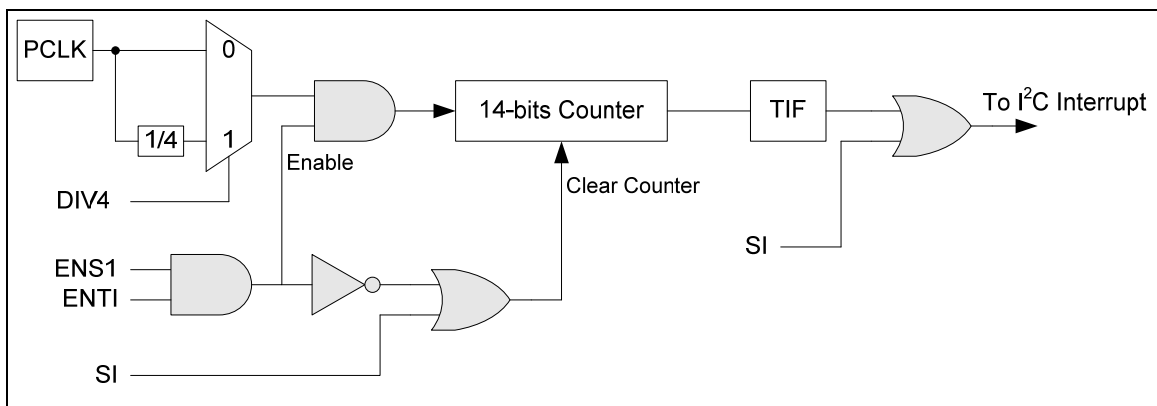

Figure 5-26: I<sup>2</sup>C Time-out Count Block Diagram



## 5.6.5 Register Map

R: read only, W: write only, R/W: both read and write

Register	Offset	R/W	Description	Reset Value
<b>I2C0_BA = 0x4002_0000</b>				
<b>I2C1_BA = 0x4012_0000</b>				
<b>I2CON</b>	I2Cx_BA+0x00	R/W	I <sup>2</sup> C Control Register	0x0000_0000
<b>I2CADDR0</b>	I2Cx_BA+0x04	R/W	I <sup>2</sup> C Slave Address Register0	0x0000_0000
<b>I2CDAT</b>	I2Cx_BA+0x08	R/W	I <sup>2</sup> C DATA Register	0x0000_0000
<b>I2CSTATUS</b>	I2Cx_BA+0x0C	R	I <sup>2</sup> C Status Register	0x0000_00F8
<b>I2CLK</b>	I2Cx_BA+0x10	R/W	I <sup>2</sup> C Clock Divided Register	0x0000_0000
<b>I2CTOC</b>	I2Cx_BA+0x14	R/W	I <sup>2</sup> C Time Out Control Register	0x0000_0000
<b>I2CADDR1</b>	I2Cx_BA+0x18	R/W	I <sup>2</sup> C Slave Address Register1	0x0000_0000
<b>I2CADDR2</b>	I2Cx_BA+0x1C	R/W	I <sup>2</sup> C Slave Address Register2	0x0000_0000
<b>I2CADDR3</b>	I2Cx_BA+0x20	R/W	I <sup>2</sup> C Slave Address Register3	0x0000_0000
<b>I2CADM0</b>	I2Cx_BA+0x24	R/W	I <sup>2</sup> C Slave Address Mask Register0	0x0000_0000
<b>I2CADM1</b>	I2Cx_BA+0x28	R/W	I <sup>2</sup> C Slave Address Mask Register1	0x0000_0000
<b>I2CADM2</b>	I2Cx_BA+0x2C	R/W	I <sup>2</sup> C Slave Address Mask Register2	0x0000_0000
<b>I2CADM3</b>	I2Cx_BA+0x30	R/W	I <sup>2</sup> C Slave Address Mask Register3	0x0000_0000



5.6.6 Register Description

**I<sup>2</sup>C Control Register (I2CON)**

Register	Offset	R/W	Description	Reset Value
I2CON	I2C_BA+0x00	R/W	I <sup>2</sup> C Control Register	0x0000_0000

31	30	29	28	27	26	25	24
Reserved							
23	22	21	20	19	18	17	16
Reserved							
15	14	13	12	11	10	9	8
Reserved							
7	6	5	4	3	2	1	0
EI	ENS1	STA	STO	SI	AA	Reserved	

Bits	Descriptions	
[31:8]	Reserved	Reserved
[7]	EI	<b>Enable Interrupt</b> 1 = Enable I <sup>2</sup> C interrupt 0 = Disable I <sup>2</sup> C interrupt
[6]	ENS1	<b>I<sup>2</sup>C Controller Enable Bit</b> 1 = Enable 0 = Disable  Set to enable I <sup>2</sup> C serial function controller. When ENS1=1 the I <sup>2</sup> C serial function enables. The multi-function pin function of SDA and SCL must set to I <sup>2</sup> C function first.
[5]	STA	<b>I<sup>2</sup>C START Control Bit</b> Setting STA to logic 1 to enter master mode, the I <sup>2</sup> C hardware sends a START or repeat START condition to bus when the bus is free.
[4]	STO	<b>I<sup>2</sup>C STOP Control Bit</b> In master mode, setting STO to transmit a STOP condition to bus then I <sup>2</sup> C hardware will check the bus condition if a STOP condition is detected this bit will be cleared by hardware automatically. In a slave mode, setting STO resets I <sup>2</sup> C hardware to the defined "not addressed" slave mode. This means it is NO LONGER in the slave receiver mode to receive data from the master transmit device.
[3]	SI	<b>I<sup>2</sup>C Interrupt Flag</b> When a new I <sup>2</sup> C state is present in the I2CSTATUS register, the SI flag is set by hardware, and if bit EI (I2CON [7]) is set, the I <sup>2</sup> C interrupt is requested. SI must be cleared by software. Clear SI is by writing 1 to this bit.



Bits	Descriptions	
[2]	<b>AA</b>	<b>Assert Acknowledge Control Bit</b> When AA=1 prior to address or data received, an acknowledged (low level to SDA) will be returned during the acknowledge clock pulse on the SCL line when 1.) A slave is acknowledging the address sent from master, 2.) The receiver devices are acknowledging the data sent by transmitter. When AA=0 prior to address or data received, a Not acknowledged (high level to SDA) will be returned during the acknowledge clock pulse on the SCL line.
[1:0]	<b>Reserved</b>	Reserved





## I<sup>2</sup>C Data Register (I2CDAT)

Register	Offset	R/W	Description	Reset Value
I2CDAT	I2C_BA+0x08	R/W	I <sup>2</sup> C Data Register	0x0000_0000

31	30	29	28	27	26	25	24
Reserved							
23	22	21	20	19	18	17	16
Reserved							
15	14	13	12	11	10	9	8
Reserved							
7	6	5	4	3	2	1	0
I2CDAT[7:0]							

Bits	Descriptions	
[31:8]	Reserved	Reserved
[7:0]	I2CDAT	I <sup>2</sup> C Data Register Bit [7:0] is located with the 8-bit transferred data of I <sup>2</sup> C serial port.



**I<sup>2</sup>C Status Register (I2CSTATUS)**

Register	Offset	R/W	Description	Reset Value
I2CSTATUS	I2C_BA+0x0C	R/W	I <sup>2</sup> C Status Register	0x0000_00F8

31	30	29	28	27	26	25	24
Reserved							
23	22	21	20	19	18	17	16
Reserved							
15	14	13	12	11	10	9	8
Reserved							
7	6	5	4	3	2	1	0
I2CSTATUS[7:3]					0	0	0

Bits	Descriptions	
[31:8]	Reserved	Reserved
[7:0]	I2CSTATUS	<p><b>I<sup>2</sup>C Status Register</b></p> <p>The status register of I<sup>2</sup>C:</p> <p>The three least significant bits are always 0. The five most significant bits contain the status code. There are 26 possible status codes. When I2CSTATUS contains F8H, no serial interrupt is requested. All other I2CSTATUS values correspond to defined I<sup>2</sup>C states. When each of these states is entered, a status interrupt is requested (SI = 1). A valid status code is present in I2CSTATUS one cycle after SI is set by hardware and is still present one cycle after SI has been reset by software. In addition, states 00H stands for a Bus Error. A Bus Error occurs when a START or STOP condition is present at an illegal position in the formation frame. Example of illegal position are during the serial transfer of an address byte, a data byte or an acknowledge bit.</p>



**I<sup>2</sup>C Clock Divided Register (I2CLK)**

Register	Offset	R/W	Description	Reset Value
I2CLK	I2C_BA+0x10	R/W	I <sup>2</sup> C Clock Divided Register	0x0000_0000

31	30	29	28	27	26	25	24
Reserved							
23	22	21	20	19	18	17	16
Reserved							
15	14	13	12	11	10	9	8
Reserved							
7	6	5	4	3	2	1	0
I2CLK[7:0]							

Bits	Descriptions	
[31:8]	Reserved	Reserved
[7:0]	I2CLK	<p><b>I<sup>2</sup>C clock divided Register</b></p> <p>The I<sup>2</sup>C clock rate bits: Data Baud Rate of I<sup>2</sup>C = (system clock) / (4x (I2CLK+1)).</p> <p>Note: the minimum value of I2CLK is 4.</p>



## I<sup>2</sup>C Time-Out Counter Register (I2CTOC)

Register	Offset	R/W	Description	Reset Value
I2CTOC	I2C_BA+0x14	R/W	I <sup>2</sup> C Time-Out Counter Register	0x0000_0000

31	30	29	28	27	26	25	24
Reserved							
23	22	21	20	19	18	17	16
Reserved							
15	14	13	12	11	10	9	8
Reserved							
7	6	5	4	3	2	1	0
Reserved					ENTI	DIV4	TIF

Bits	Descriptions	
[31:3]	Reserved	Reserved
[2]	ENTI	<p><b>Time-out counter is enabled/disable</b></p> <p>1 = Enable 0 = Disable</p> <p>When Enable, the 14-bit time-out counter will start counting when SI is clear. Setting flag SI to high will reset counter and re-start up counting after SI is cleared.</p>
[1]	DIV4	<p><b>Time-Out counter input clock is divided by 4</b></p> <p>1 = Enable 0 = Disable</p> <p>When Enable, The time-Out period is extend 4 times.</p>
[0]	TIF	<p><b>Time-Out Flag</b></p> <p>This bit is set by H/W when I<sup>2</sup>C time-out happened and it can interrupt CPU if I<sup>2</sup>C interrupt enable bit (EI) is set to 1.</p> <p>S/W can write 1 to clear this bit.</p>



## I<sup>2</sup>C Slave Address Register (I2CADDRx)

Register	Offset	R/W	Description	Reset Value
I2CADDR0	I2C_BA+0x04	R/W	I <sup>2</sup> C Slave Address Register0	0x0000_0000
I2CADDR1	I2C_BA+0x18	R/W	I <sup>2</sup> C Slave Address Register1	0x0000_0000
I2CADDR2	I2C_BA+0x1C	R/W	I <sup>2</sup> C Slave Address Register2	0x0000_0000
I2CADDR3	I2C_BA+0x20	R/W	I <sup>2</sup> C Slave Address Register3	0x0000_0000

31	30	29	28	27	26	25	24
Reserved							
23	22	21	20	19	18	17	16
Reserved							
15	14	13	12	11	10	9	8
Reserved							
7	6	5	4	3	2	1	0
I2CADDR[7:1]							GC

Bits	Descriptions	
[31:8]	Reserved	Reserved
[7:1]	I2CADDR	<b>I<sup>2</sup>C Address Register</b> The content of this register is irrelevant when I <sup>2</sup> C is in master mode. In the slave mode, the seven most significant bits must be loaded with the chip's own address. The I <sup>2</sup> C hardware will react if either of the address is matched.
[0]	GC	<b>General Call Function</b> 0 = Disable General Call Function. 1 = Enable General Call Function.



**I<sup>2</sup>C Slave Address Mask Register (I2CADMx)**

Register	Offset	R/W	Description	Reset Value
I2CADM0	I2C_BA+0x24	R/W	I <sup>2</sup> C Slave Address Mask Register0	0x0000_0000
I2CADM1	I2C_BA+0x28	R/W	I <sup>2</sup> C Slave Address Mask Register1	0x0000_0000
I2CADM2	I2C_BA+0x2C	R/W	I <sup>2</sup> C Slave Address Mask Register2	0x0000_0000
I2CADM3	I2C_BA+0x30	R/W	I <sup>2</sup> C Slave Address Mask Register3	0x0000_0000

31	30	29	28	27	26	25	24
Reserved							
23	22	21	20	19	18	17	16
Reserved							
15	14	13	12	11	10	9	8
Reserved							
7	6	5	4	3	2	1	0
I2CADM[7:1]							Reserved

Bits	Descriptions	
[31:8]	Reserved	Reserved
[7:1]	I2CADM	<p><b>I<sup>2</sup>C Address Mask register</b></p> <p>1 = Mask enable (the received corresponding address bit is don't care.)</p> <p>0 = Mask disable (the received corresponding register bit should be exact the same as address register.)</p> <p>I<sup>2</sup>C bus controllers support multiple address recognition with four address mask register. When the bit in the address mask register is set to one, it means the received corresponding address bit is don't-care. If the bit is set to zero, that means the received corresponding register bit should be exact the same as address register.</p>
[0]	Reserved	Reserved

## 5.6.7 Modes of Operation

The on-chip I<sup>2</sup>C ports support five operation modes, Master transmitter, Master receiver, Slave transmitter, Slave receiver, and GC call.

In a given application, I<sup>2</sup>C port may operate as a master or as a slave. In the slave mode, the I<sup>2</sup>C port hardware looks for its own slave address and the general call address. If one of these addresses is detected, and if the slave is willing to receive or transmit data from/to master (by setting the AA bit), acknowledge pulse will be transmitted out on the 9th clock, hence an interrupt is requested on both master and slave devices if interrupt is enabled. When the microcontroller wishes to become the bus master, the hardware waits until the bus is free before the master mode is entered so that a possible slave action didn't be interrupted. If bus arbitration is lost in the master mode, I<sup>2</sup>C port switches to the slave mode immediately and can detect its own slave address in the same serial transfer.

Bits STA, STO and AA in I2CON register will determine the next state of the I<sup>2</sup>C hardware after SI flag is cleared. Upon completion of the new action, a new status code will be updated and the SI flag will be set. If the I<sup>2</sup>C interrupt control bit EI (I2CON [7]) is set, appropriate action or software branch of the new status code can be performed in the Interrupt service routine.

In the following description of five operation modes, detailed data flow is represented. The legend for those data flow figures is shown in Figure 5-27

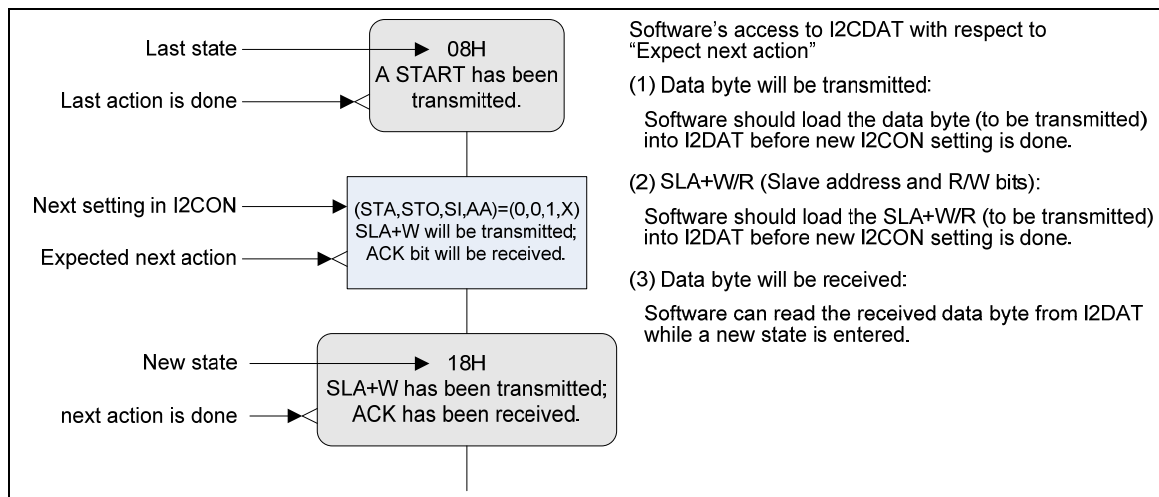

Figure 5-27 Legend for the following five figures



5.6.7.1 Master Transmitter Mode

As shown in Figure 5-28, in master transmitter mode, serial data output through SDA while SCL outputs the serial clock. The first byte transmitted contains the slave address of the receiving device (7-bit) and the data direction bit. In this case the data direction bit (R/W) will be logic 0, and it is represented by “W” in the Figure 5-20. Thus the first byte transmitted is SLA+W. Serial data is transmitted 8-bit at a time. After each byte is transmitted, an acknowledge bit is received. START and STOP conditions are output to indicate the beginning and the end of a serial transfer.

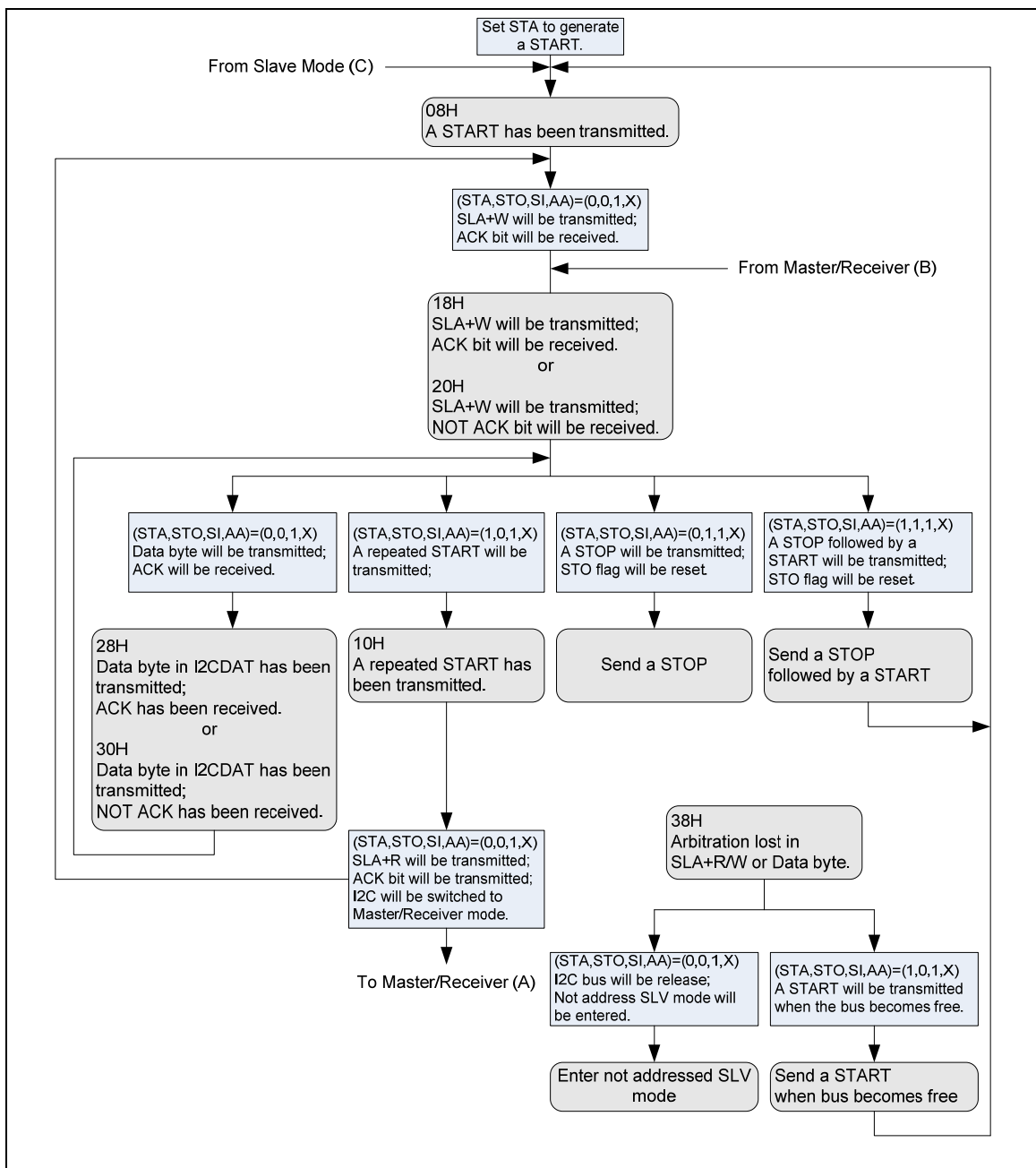

Figure 5-28 Master Transmitter Mode



## 5.6.7.2 Master Receiver Mode

As shown in Figure 5-29, in this case the data direction bit (R/W) will be logic 1, and it is represented by “R” in the Figure 5-21. Thus the first byte transmitted is SLA+R. Serial data is received via SDA while SCL outputs the serial clock. Serial data is received 8-bit at a time. After each byte is received, an acknowledge bit is transmitted. START and STOP conditions are output to indicate the beginning and end of a serial transfer.

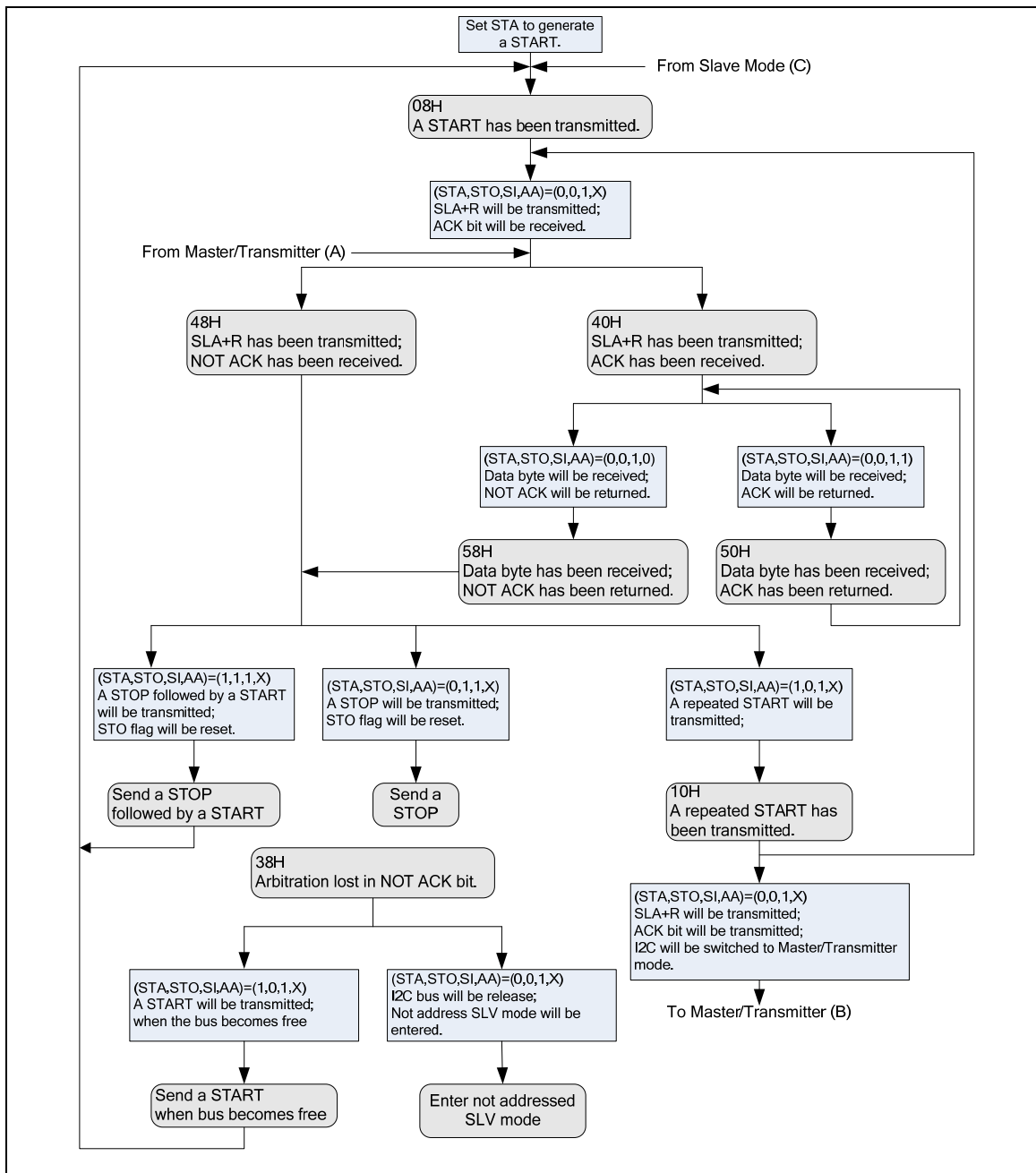

Figure 5-29 Master Receiver Mode

## 5.6.7.3 Slave Receiver Mode

As shown in Figure 5-30, serial data and the serial clock are received through SDA and SCL. After each byte is received, an acknowledge bit is transmitted. START and STOP conditions are recognized as the beginning and end of a serial transfer. Address recognition is performed by hardware after reception of the slave address and direction bit.

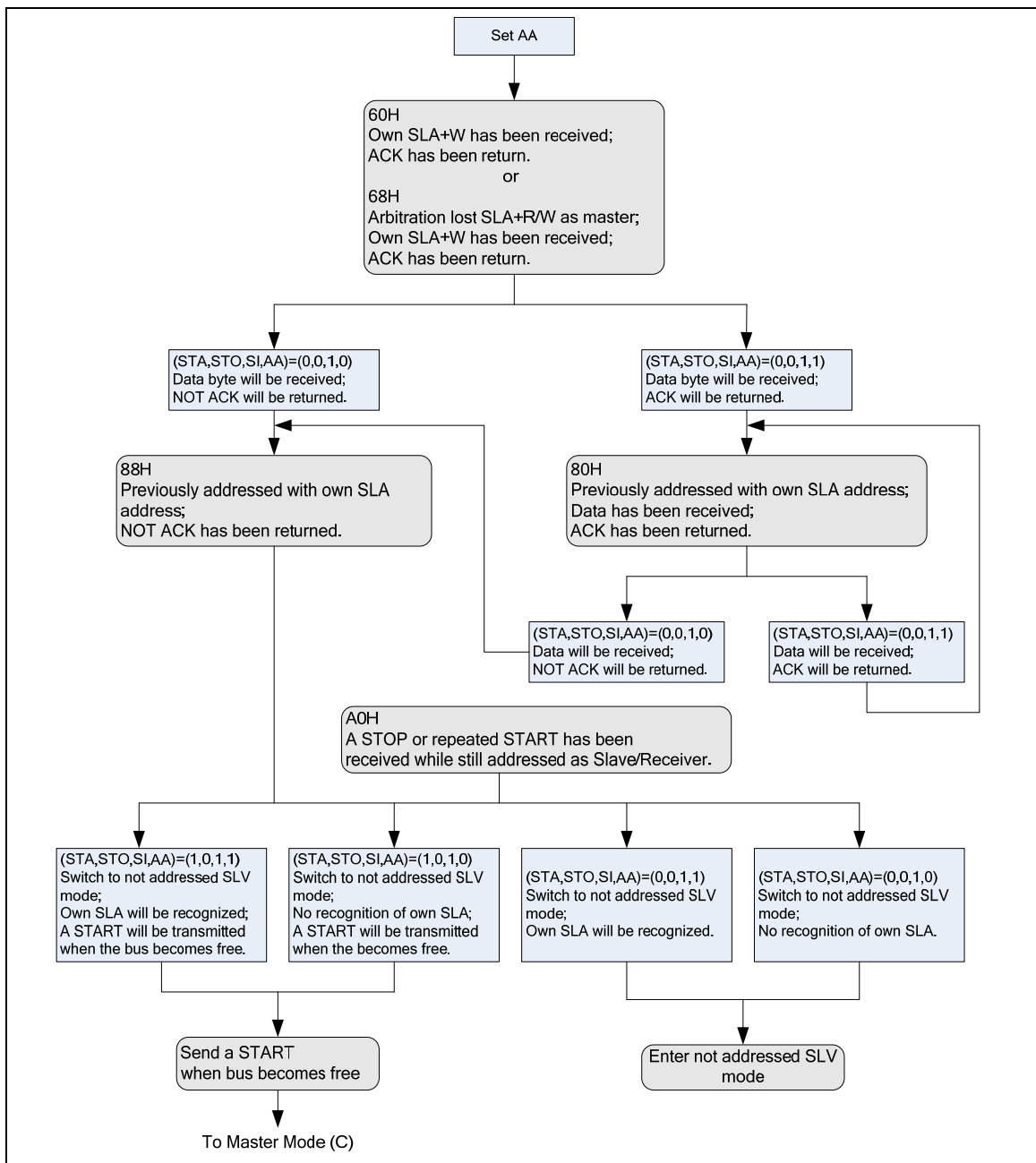

Figure 5-30 Slave Receiver Mode

## 5.6.7.4 Slave Transmitter Mode

As shown in Figure 5-31, the first byte is received and handled as in the slave receiver mode. However, in this mode, the direction bit will indicate that the transfer direction is reversed. Serial data is transmitted via SDA while the serial clock is input through SCL. START and STOP conditions are recognized as the beginning and end of a serial transfer.

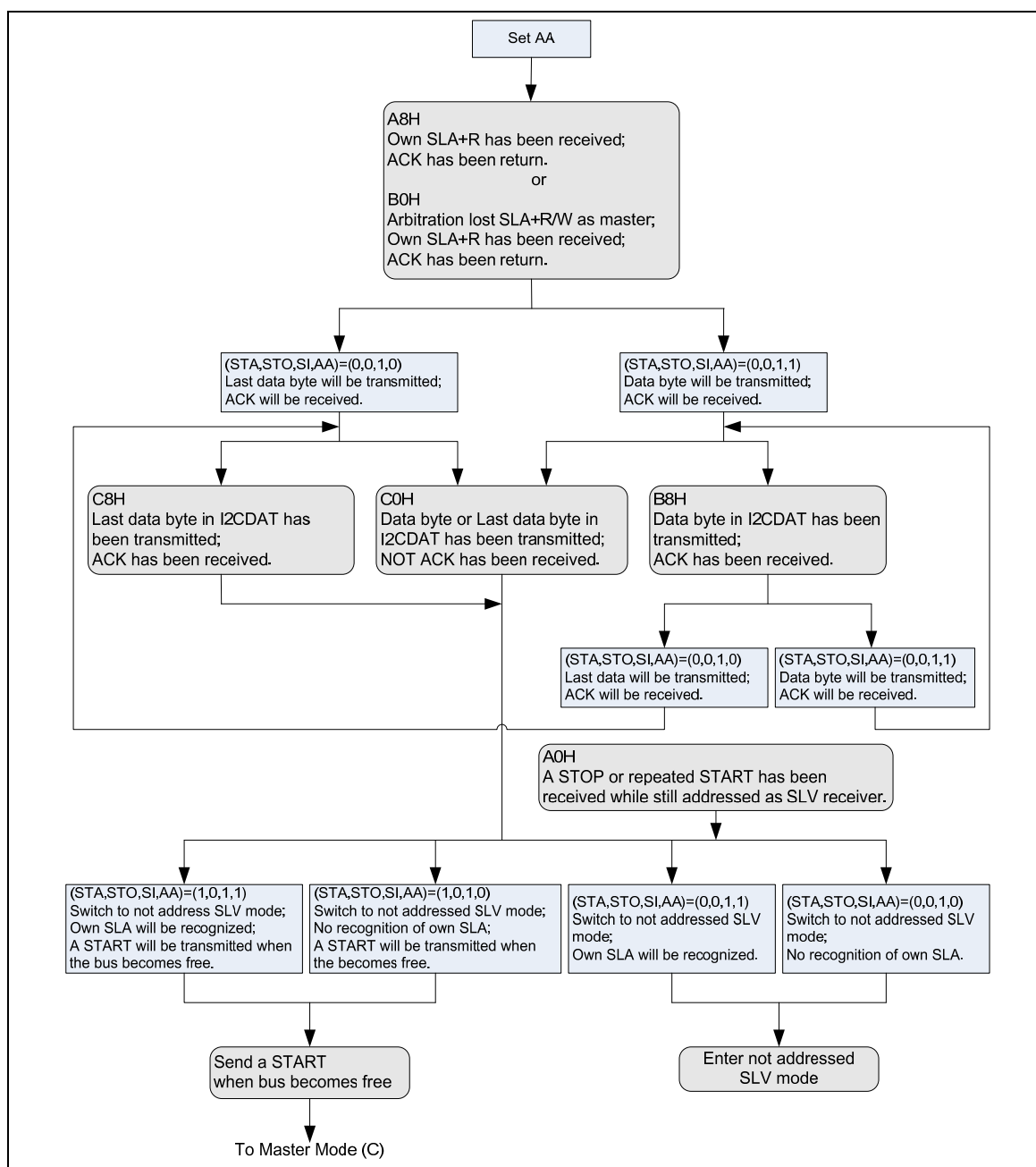

Figure 5-31 Slave Transmitter Mode

## 5.6.7.5 General Call (GC) Mode

As shown in Figure 5-32, if the GC bit (I2CADDRn [0]) is set, the I<sup>2</sup>C port hardware will respond to General Call address (00H). Clear GC bit to disable general call function. When GC bit is set and the I<sup>2</sup>C is in Slave mode, it can receive the general call address by 00H after Master send general call address to I<sup>2</sup>C bus, then it will follow status of GC mode. Serial data and the serial clock are received through SDA and SCL. After each byte is received, an acknowledge bit is transmitted. START and STOP conditions are recognized as the beginning and end of a serial transfer. Address recognition is performed by hardware after reception of the slave address and direction bit.

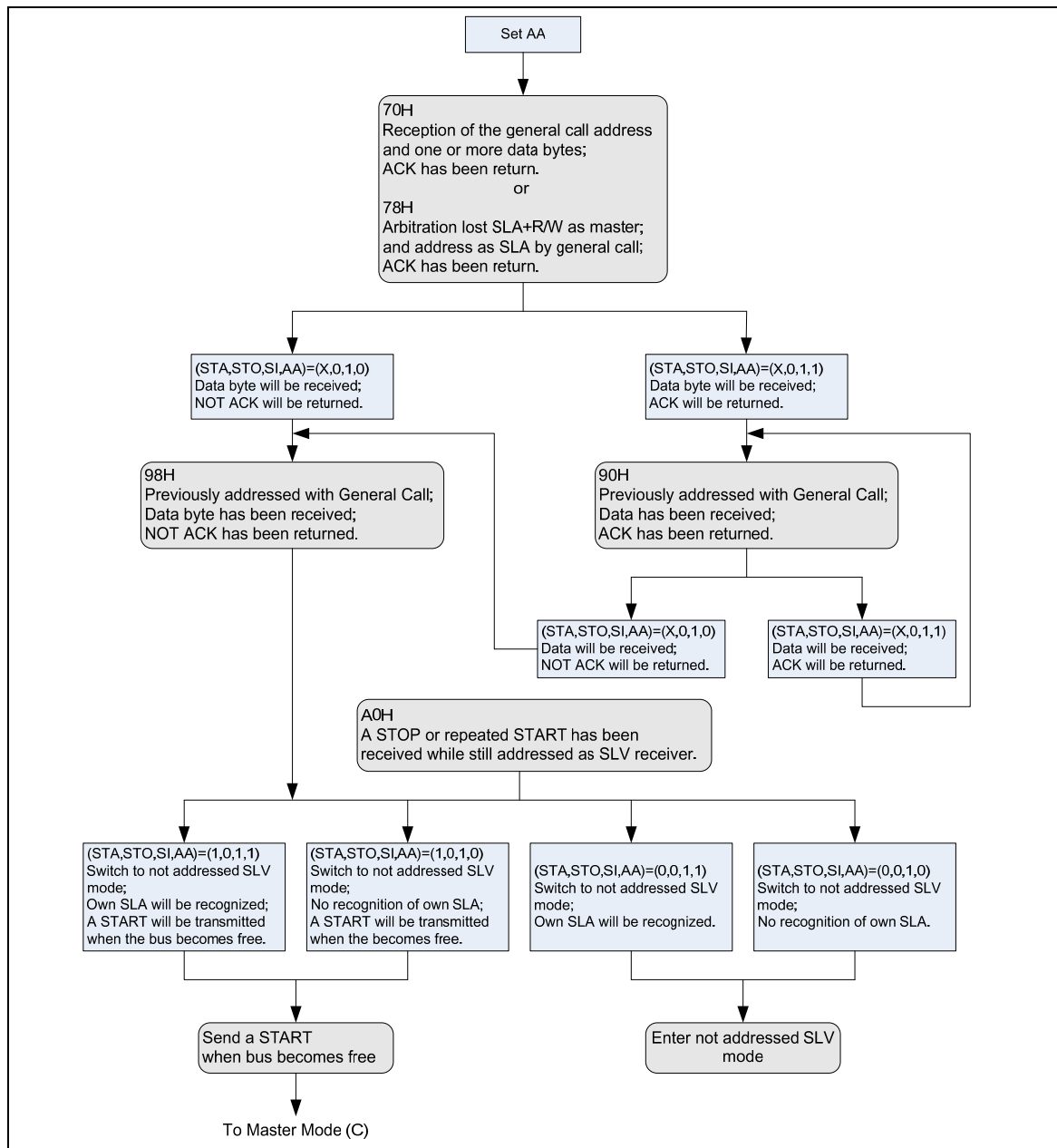

Figure 5-32 GC Mode

## 5.7 PWM Generator and Capture Timer (PWM)

### 5.7.1 Overview

NuMicro™ NUC100/NUC120 Medium Density has 2 sets of PWM group supports total 4 sets of PWM Generators which can be configured as 8 independent PWM outputs, PWM0~PWM7, or as 4 complementary PWM pairs, (PWM0, PWM1), (PWM2, PWM3), (PWM4, PWM5) and (PWM6, PWM7) with 4 programmable dead-zone generators. NuMicro™ NUC100/NUC120 Low Density only support 1 set of PWM group supports total 2 sets of PWM Generators which can be configured as 4 independent PWM outputs, PWM0~PWM3, or as 2 complementary PWM pairs, (PWM0, PWM1) and (PWM2, PWM3) with 2 programmable dead-zone generators.

Each PWM Generator has one 8-bit prescaler, one clock divider with 5 divided frequencies (1, 1/2, 1/4, 1/8, 1/16), two PWM Timers including two clock selectors, two 16-bit PWM down-counters for PWM period control, two 16-bit comparators for PWM duty control and one dead-zone generator. The 4 sets of PWM Generators provide eight independent PWM interrupt flags which are set by hardware when the corresponding PWM period down counter reaches zero. Each PWM interrupt source with its corresponding enable bit can cause CPU to request PWM interrupt. The PWM generators can be configured as one-shot mode to produce only one PWM cycle signal or auto-reload mode to output PWM waveform continuously.

When PCR.DZEN01 is set, PWM0 and PWM1 perform complementary PWM paired function; the paired PWM period, duty and dead-time are determined by PWM0 timer and Dead-zone generator 0. Similarly, the complementary PWM pairs of (PWM2, PWM3), (PWM4, PWM5) and (PWM6, PWM7) are controlled by PWM2, PWM4 and PWM6 timers and Dead-zone generator 2, 4 and 6, respectively. Refer to Figure 5-33 to Figure 5-40 for the architecture of PWM Timers.

To prevent PWM driving output pin with unsteady waveform, the 16-bit period down counter and 16-bit comparator are implemented with double buffer. When user writes data to counter/comparator buffer registers the updated value will be load into the 16-bit down counter/comparator at the time down counter reaching zero. The double buffering feature avoids glitch at PWM outputs.

When the 16-bit period down counter reaches zero, the interrupt request is generated. If PWM-timer is set as auto-reload mode, when the down counter reaches zero, it is reloaded with PWM Counter Register (CNRx) automatically then start decreasing, repeatedly. If the PWM-timer is set as one-shot mode, the down counter will stop and generate one interrupt request when it reaches zero.

The value of PWM counter comparator is used for pulse high width modulation. The counter control logic changes the output to high level when down-counter value matches the value of compare register.

The alternate feature of the PWM-timer is digital input Capture function. If Capture function is enabled the PWM output pin is switched as capture input mode. The Capture0 and PWM0 share one timer which is included in PWM0 and the Capture1 and PWM1 share PWM1 timer, and etc. Therefore user must setup the PWM-timer before enable Capture feature. After capture feature is enabled, the capture always latched PWM-counter to Capture Rising Latch Register (CRLR) when input channel has a rising transition and latched PWM-counter to Capture Falling Latch Register (CFLR) when input channel has a falling transition. Capture channel 0 interrupt is programmable by setting CCR0.CRL\_IE0[1] (Rising latch Interrupt enable) and CCR0.CFL\_IE0[2] (Falling latch Interrupt enable) to decide the condition of interrupt occur. Capture channel 1 has the same feature by setting CCR0.CRL\_IE1[17] and CCR0.CFL\_IE1[18]. And capture channel 2 to channel 3 on each group have the same feature by setting the corresponding control bits in CCR2. For each group, whenever Capture issues Interrupt 0/1/2/3,



the PWM counter 0/1/2/3 will be reload at this moment.

The maximum captured frequency that PWM can capture is confined by the capture interrupt latency. When capture interrupt occurred, software will do at least three steps, they are: Read PIIR to get interrupt source and Read CRLRx/CFLRx(x=0~3) to get capture value and finally write 1 to clear PIIR to zero. If interrupt latency will take time T0 to finish, the capture signal mustn't transition during this interval (T0). In this case, the maximum capture frequency will be 1/T0. For example:

HCLK = 50 MHz, PWM\_CLK = 25 MHz, Interrupt latency is 900 ns

So the maximum capture frequency will is  $1/900\text{ns} \approx 1000\text{ kHz}$

## 5.7.2 Features

### 5.7.2.1 PWM function features:

- PWM group has two PWM generators. Each PWM generator supports one 8-bit prescaler, one clock divider, two PWM-timers (down counter), one dead-zone generator and two PWM outputs.
- Up to 16-bit resolution
- PWM Interrupt request synchronized with PWM period
- One-shot or Auto-reload mode PWM
- Up to 2 PWM group (PWMA/PWMB) to support 8 PWM channels or 4 PWM paired channels (only 1 PWM group support for NuMicro™ NUC100/NUC120 Low Density)

### 5.7.2.2 Capture Function Features:

- Timing control logic shared with PWM Generators
- Support 8 Capture input channels shared with 8 PWM output channels (NuMicro™ NUC100/NUC120 Low Density only support 4 Capture input channels shared with 4 PWM output channels)
- Each channel supports one rising latch register (CRLR), one falling latch register (CFLR) and Capture interrupt flag (CAPIFx)

### 5.7.3 Block Diagram

The Figure 5-33 to Figure 5-40 illustrate the architecture of PWM in pair (PWM-Timer 0 and 1 are in one pair and PWM-Timer 2, 3 are in another one, and so on.).

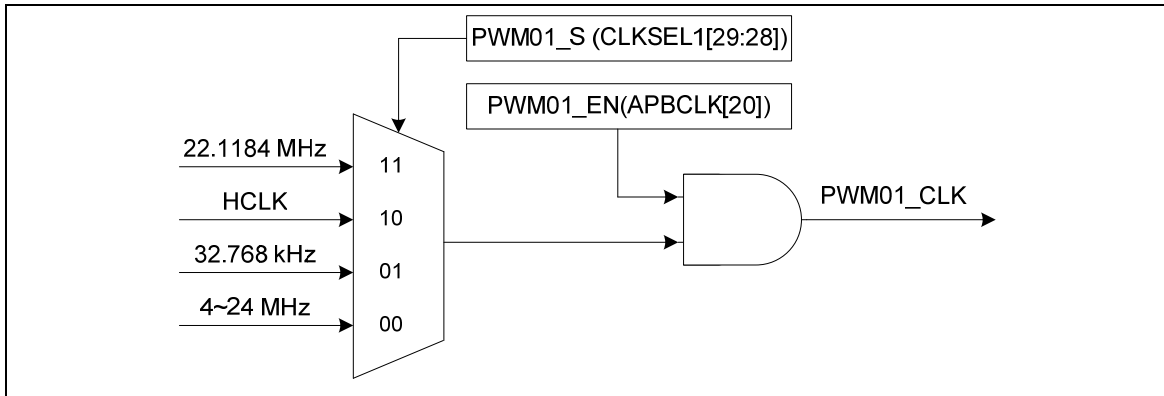

Figure 5-33 PWM Generator 0 Clock Source Control

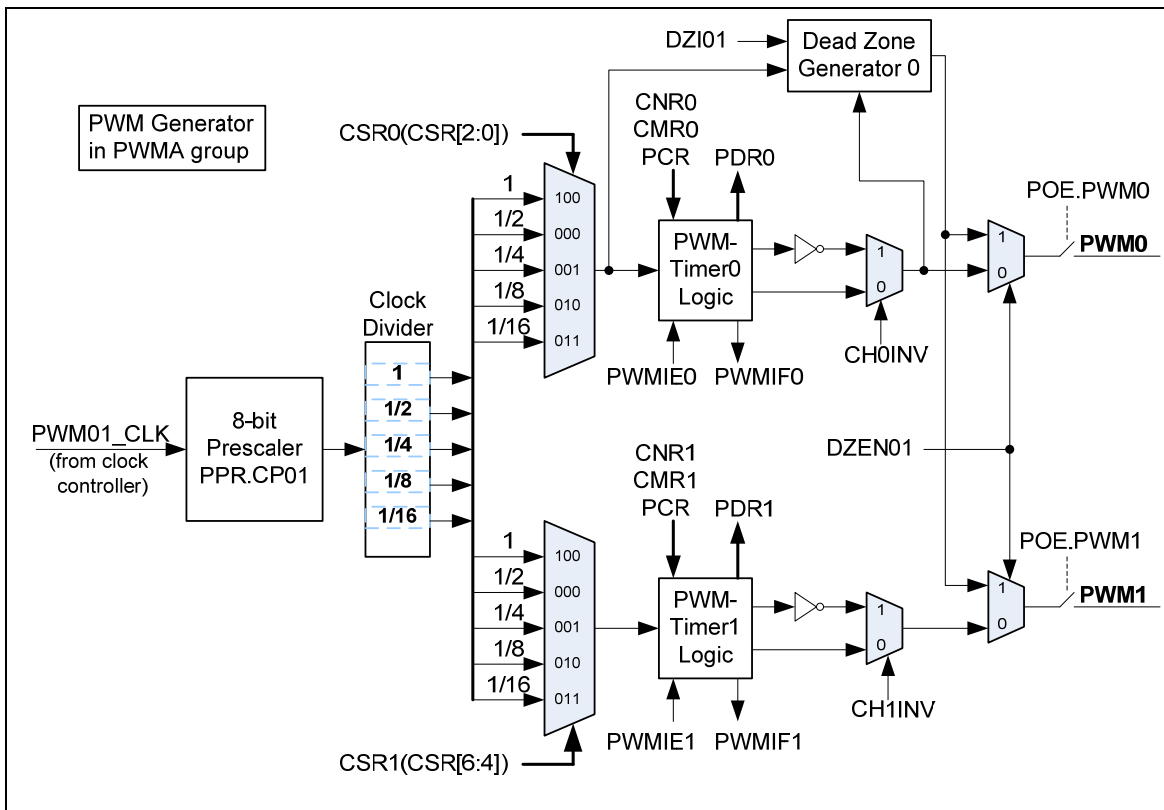

Figure 5-34 PWM Generator 0 Architecture Diagram

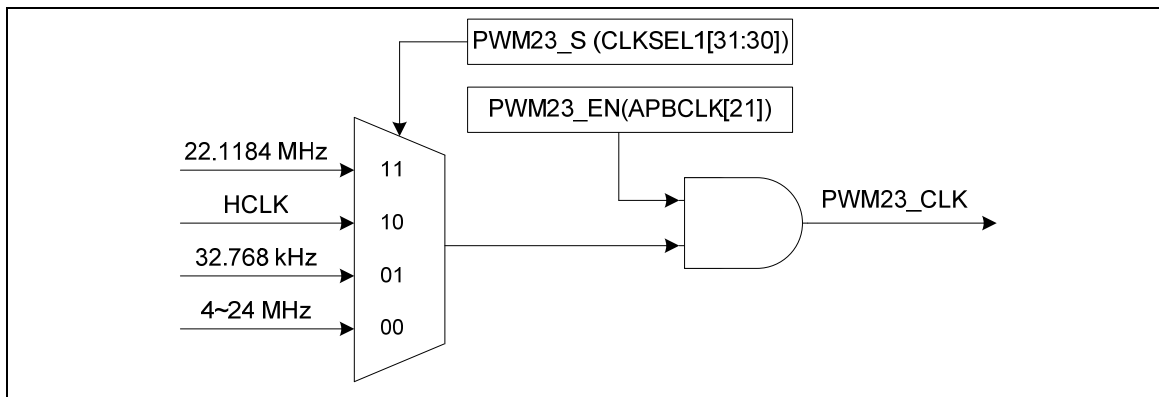

Figure 5-35 PWM Generator 2 Clock Source Control

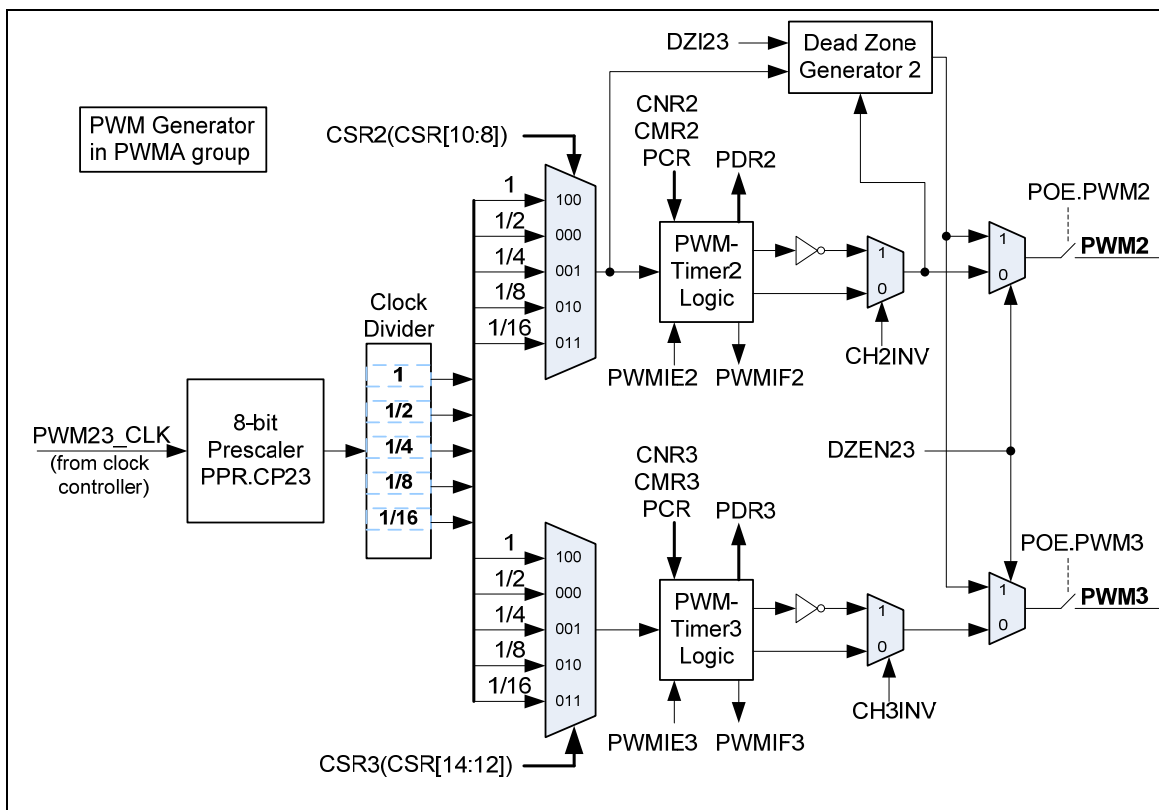

Figure 5-36 PWM Generator 2 Architecture Diagram



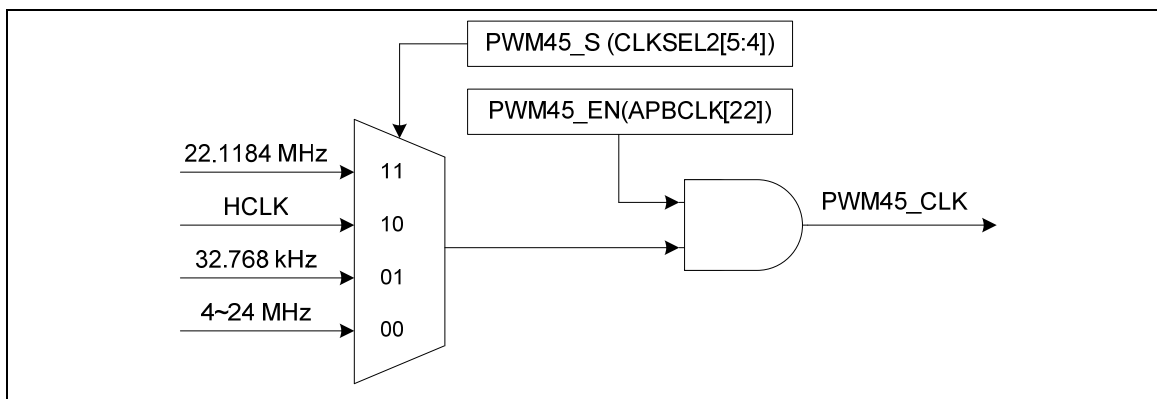

Figure 5-37 PWM Generator 4 Clock Source Control

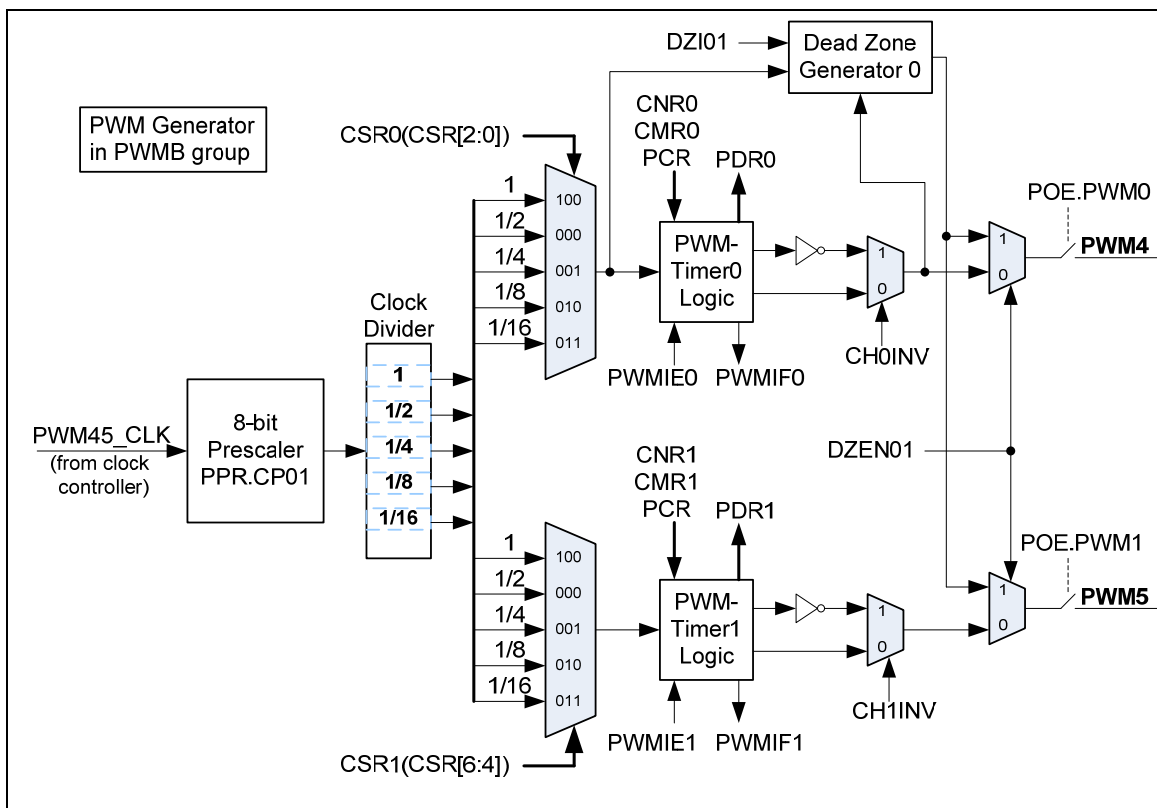

Figure 5-38 PWM Generator 4 Architecture Diagram

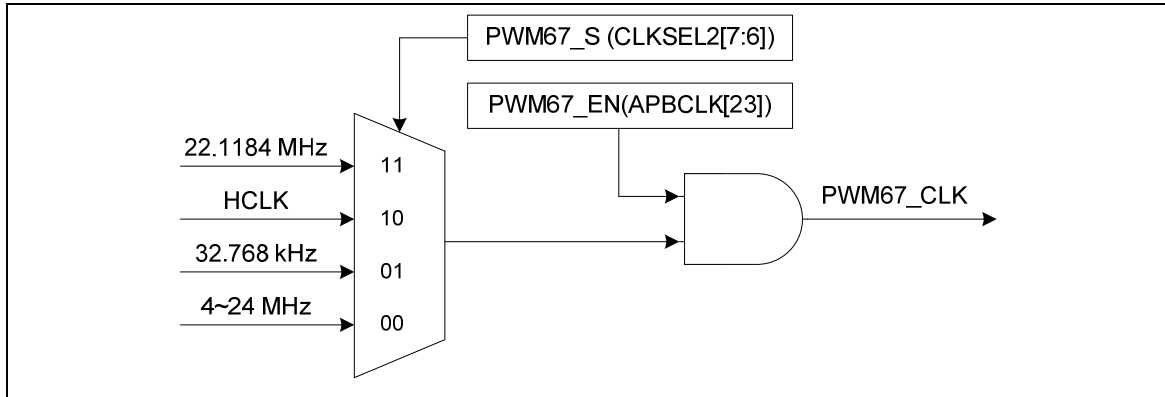

Figure 5-39 PWM Generator 6 Clock Source Control

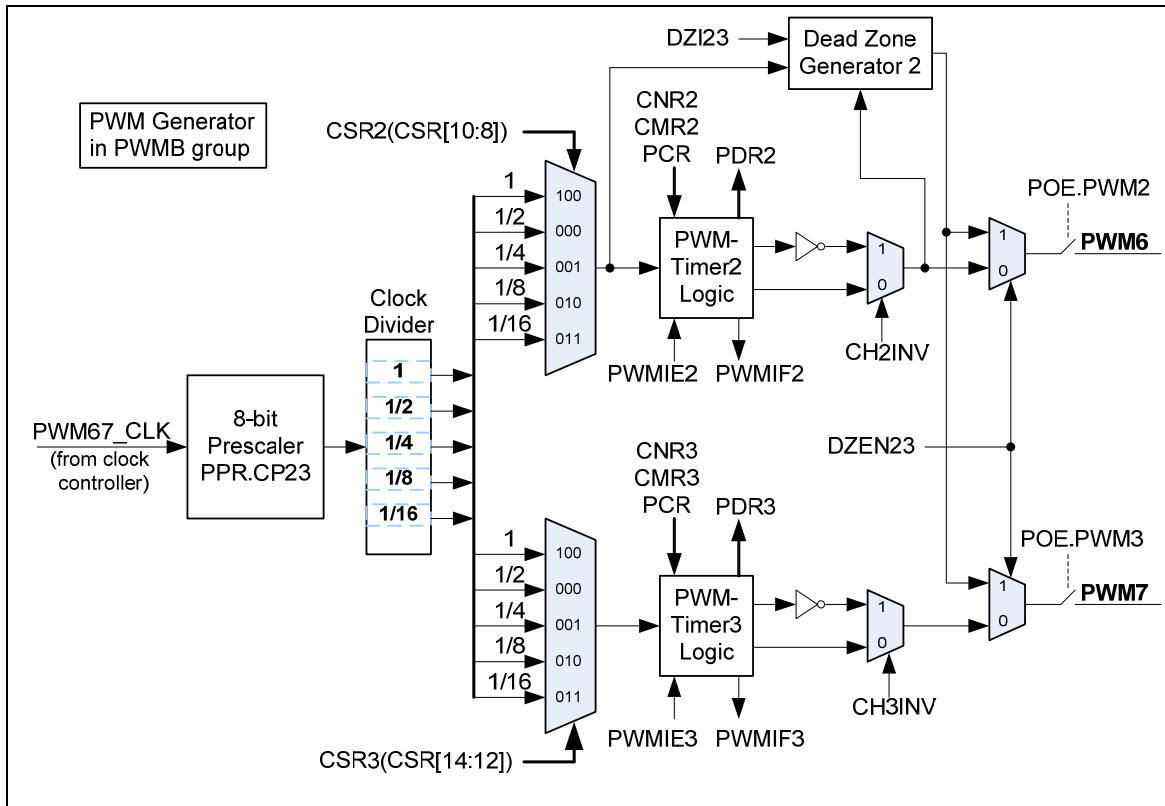

Figure 5-40 PWM Generator 6 Architecture Diagram

## 5.7.4 Function Description

### 5.7.4.1 PWM-Timer Operation

The PWM period and duty control are configured by PWM down-counter register (CNR) and PWM comparator register (CMR). The PWM-timer timing operation is shown in Figure 5-42. The pulse width modulation follows the formula as below and the legend of PWM-Timer Comparator is shown as Figure 5-41. Note that the corresponding GPIO pins must be configured as PWM function (enable POE and disable CAPENR) for the corresponding PWM channel.

- PWM frequency =  $\text{PWM}_{xy\_CLK} / [(\text{prescale}+1) * (\text{clock divider}) * (\text{CNR}+1)]$ ; where xy, could be 01, 23, 45 or 67, depends on selected PWM channel.
- Duty ratio =  $(\text{CMR}+1) / (\text{CNR}+1)$
- $\text{CMR} \geq \text{CNR}$ : PWM output is always high
- $\text{CMR} < \text{CNR}$ : PWM low width =  $(\text{CNR}-\text{CMR})$  unit[1]; PWM high width =  $(\text{CMR}+1)$  unit
- $\text{CMR} = 0$ : PWM low width =  $(\text{CNR})$  unit; PWM high width = 1 unit

Note: [1] Unit = one PWM clock cycle.

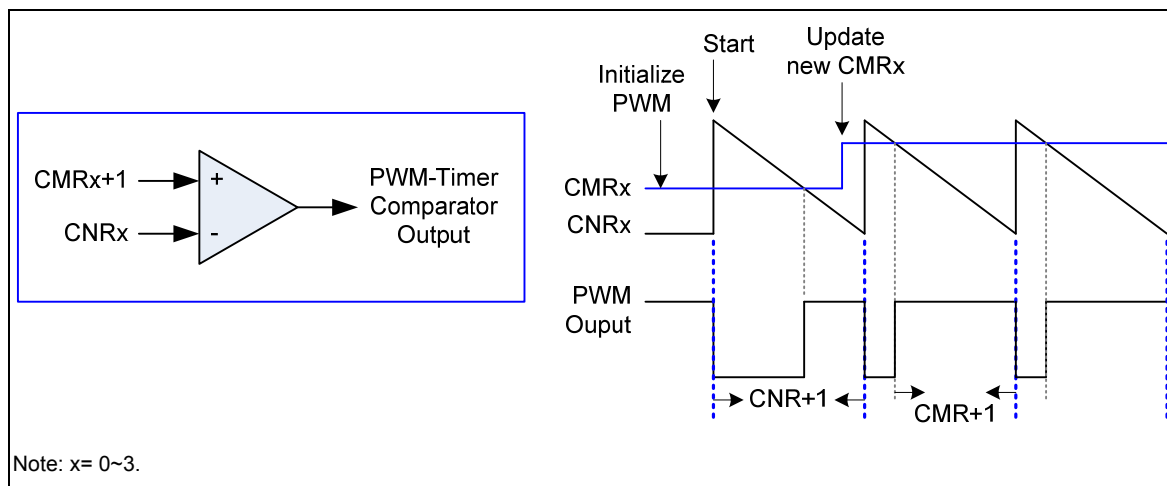

Figure 5-41 Legend of Internal Comparator Output of PWM-Timer

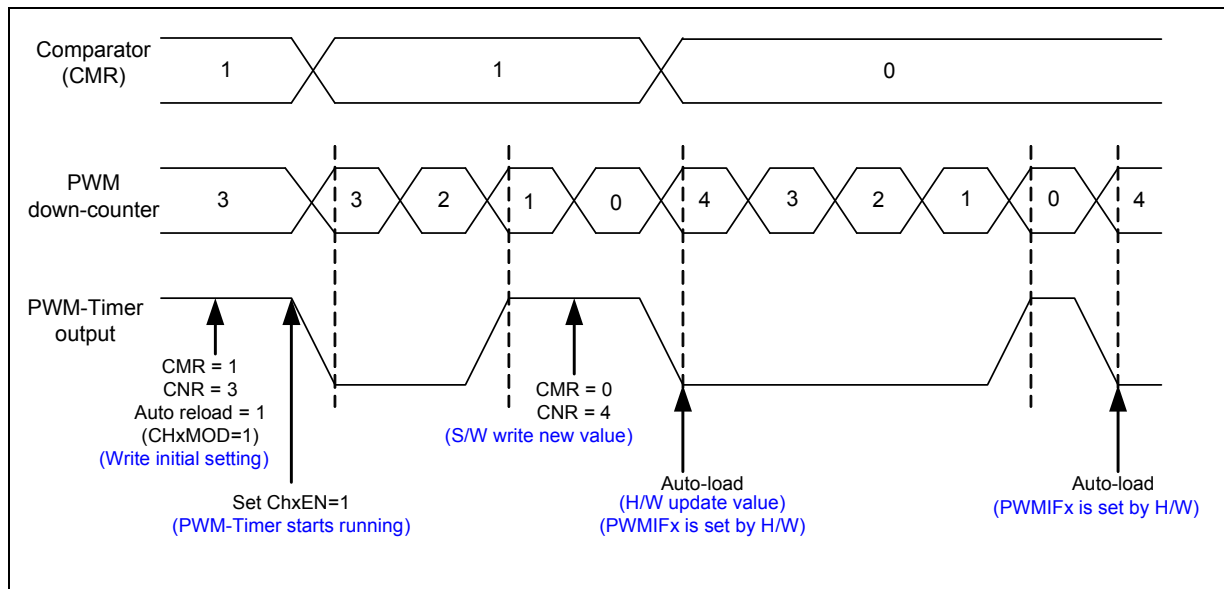

Figure 5-42 PWM-Timer Operation Timing

#### 5.7.4.2 PWM Double Buffering, Auto-reload and One-shot Operation

PWM Timers have double buffering function the reload value is updated at the start of next period without affecting current timer operation. The PWM counter value can be written into CNRx and current PWM counter value can be read from PDRx.

PWM0 will operate at one-shot mode if CH0MOD bit is set to 0, and operate at auto-reload mode if CH0MOD bit is set to 1. It is recommend that switch PWM0 operating mode before set CH0EN bit to 1 to enable PWM0 counter start running because the content of CNR0 and CMR0 will be cleared to zero to reset the PWM0 period and duty setting when PWM0 operating mode is changed. As PWM0 operate at one-shot mode, CMR0 and CNR0 should be written first and then set CH0EN bit to 1 to enable PWM0 counter start running. After PWM0 counter down count from CNR0 value to zero, CNR0 and CMR0 will be cleared to zero by hardware and PWM counter will be held. Software need to write new CMR0 and CNR0 value to set next one-shot period and duty. When re-start next one-shot operation, the CMR0 should be written first because PWM0 counter will auto re-start counting when CNR0 is written an non-zero value. As PWM0 operate at auto-reload mode, CMR0 and CNR0 should be written first and then set CH0EN bit to 1 to enable PWM0 counter start running. The value of CNR0 will reload to PWM0 counter when it down count reaches zero. If CNR0 is set to zero, PWM0 counter will be held. PWM1~PWM7 performs the same function as PWM0.

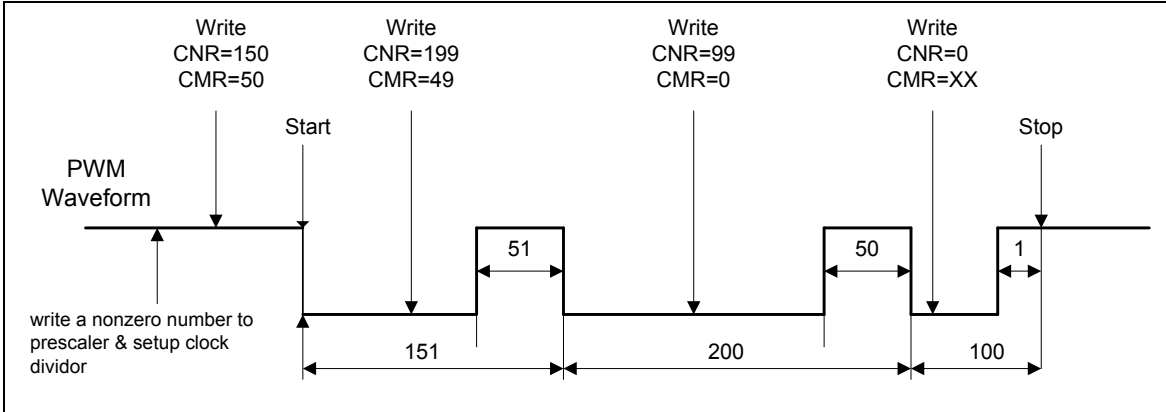

Figure 5-43 PWM Double Buffering Illustration

### 5.7.4.3 Modulate Duty Ratio

The double buffering function allows CMRx written at any point in current cycle. The loaded value will take effect from next cycle.

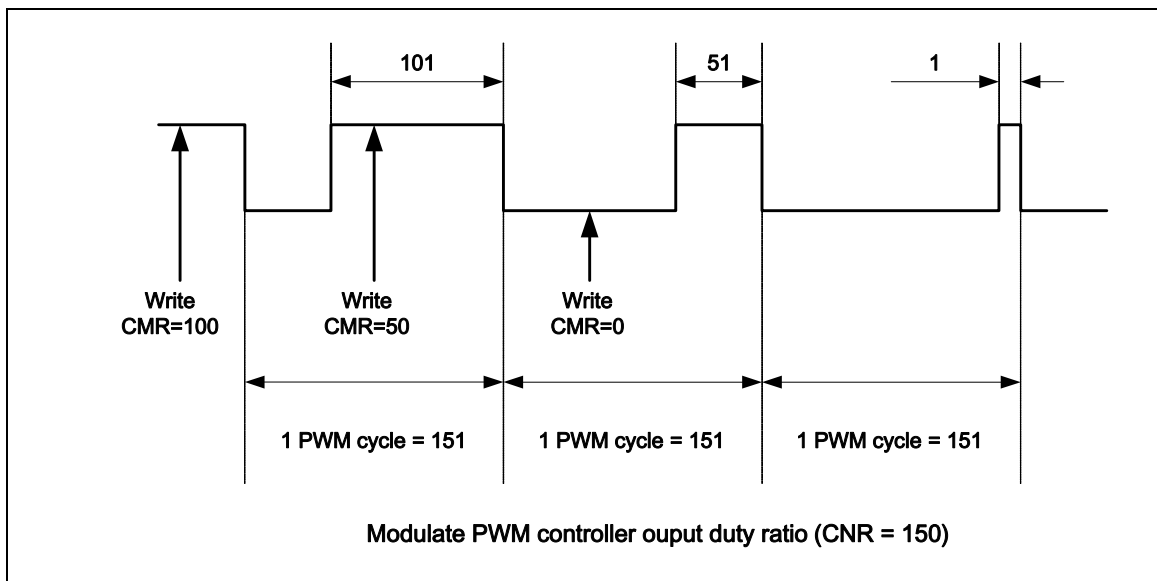

Figure 5-44 PWM Controller Output Duty Ratio

### 5.7.4.4 Dead-Zone Generator

PWM controller is implemented with Dead Zone generator. They are built for power device protection. This function generates a programmable time gap to delay PWM rising output. User can program PPRx.DZI to determine the Dead Zone interval.

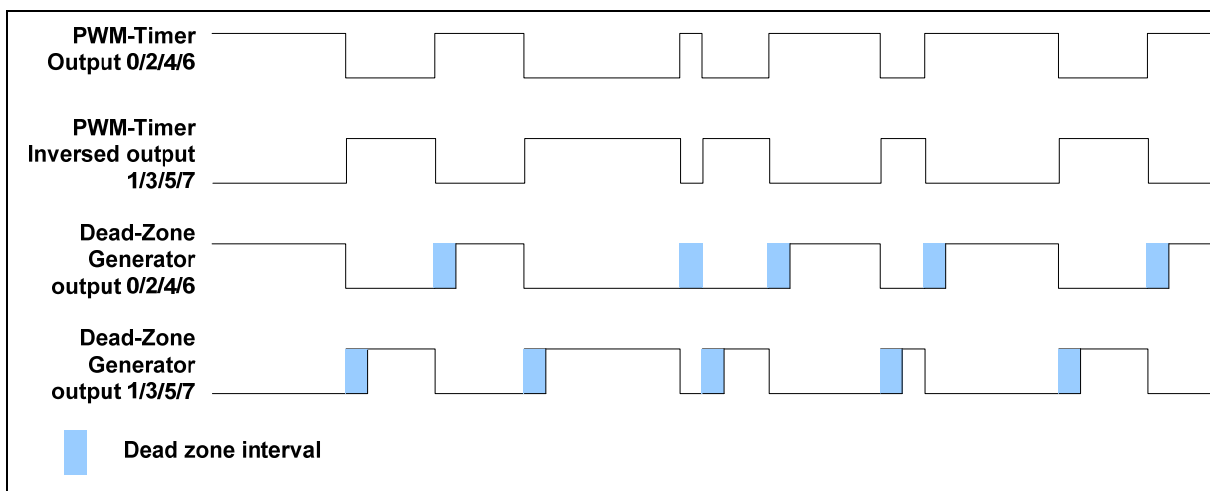

Figure 5-45 Paired-PWM Output with Dead Zone Generation Operation

## 5.7.4.5 Capture Operation

The Capture 0 and PWM 0 share one timer that included in PWM 0; and the Capture 1 and PWM 1 share another timer, and etc. The capture always latches PWM-counter to CRLRx when input channel has a rising transition and latches PWM-counter to CFLRx when input channel has a falling transition. Capture channel 0 interrupt is programmable by setting CCR0[1] (Rising latch Interrupt enable) and CCR0[2] (Falling latch Interrupt enable) to decide the condition of interrupt occur. Capture channel 1 has the same feature by setting CCR0[17] and CCR0[18], and etc. Whenever the Capture controller issues a capture interrupt, the corresponding PWM counter will be reloaded with CNRx at this moment. Note that the corresponding GPIO pins must be configured as capture function (disable POE and enable CAPENR) for the corresponding capture channel.

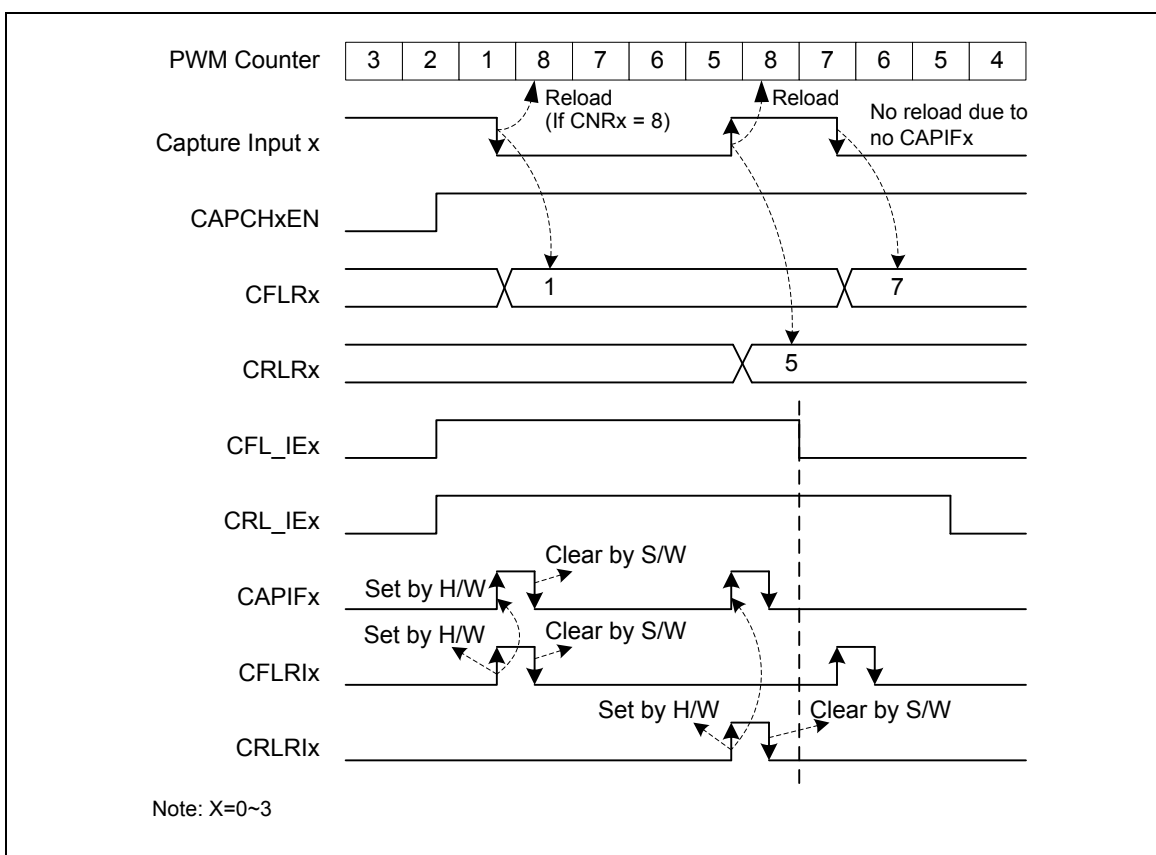

Figure 5-46 Capture Operation Timing

At this case, the CNR is 8:

1. The PWM counter will be reloaded with CNRx when a capture interrupt flag (CAPIFx) is set.
2. The channel low pulse width is  $(CNR + 1 - CRLR)$ .
3. The channel high pulse width is  $(CNR + 1 - CFLR)$ .

## 5.7.4.6 PWM-Timer Interrupt Architecture

There are eight PWM interrupts, PWM0\_INT~PWM7\_INT, which are divided into PWMA\_INT and PWMB\_INT for Advanced Interrupt Controller (AIC). PWM 0 and Capture 0 share one interrupt, PWM1 and Capture 1 share the same interrupt and so on. Therefore, PWM function and Capture function in the same channel cannot be used at the same time. Figure 5-47 and Figure 5-48 demonstrates the architecture of PWM-Timer interrupts.

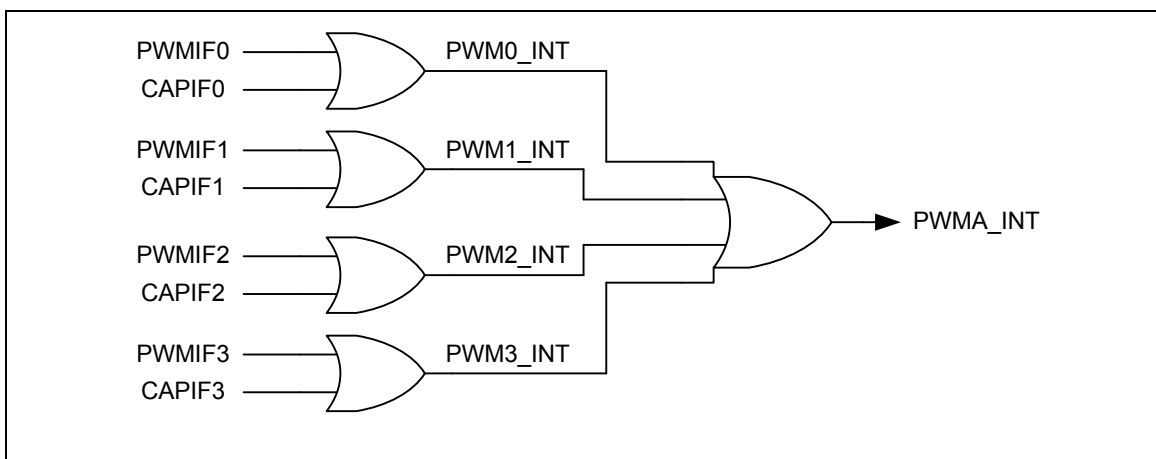

Figure 5-47 PWM Group A PWM-Timer Interrupt Architecture Diagram

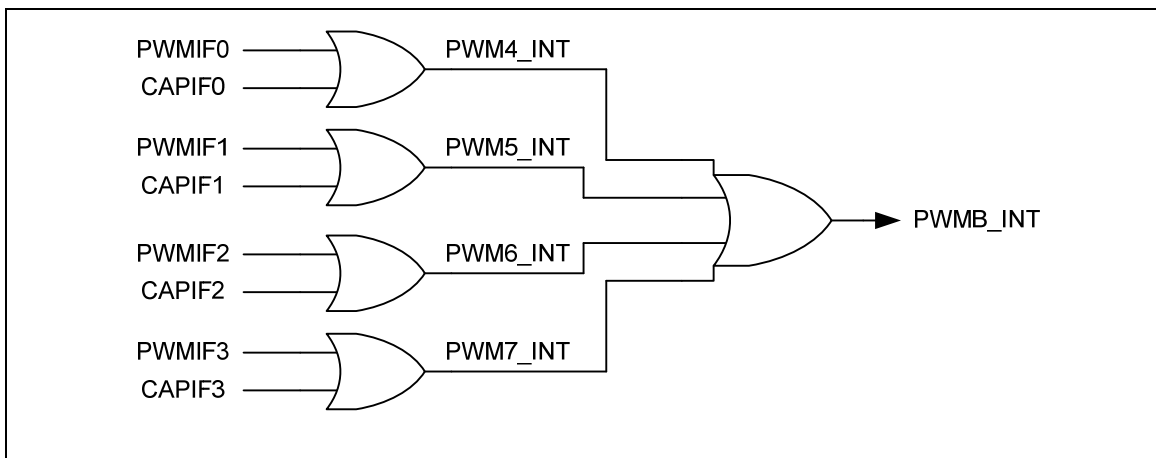

Figure 5-48 PWM Group B PWM-Timer Interrupt Architecture Diagram





#### 5.7.4.7 PWM-Timer Start Procedure

The following procedure is recommended for starting a PWM drive.

1. Setup clock source divider select register (CSR)
2. Setup prescaler (PPR)
3. Setup inverter on/off, dead zone generator on/off, auto-reload/one-shot mode and Stop PWM-timer (PCR)
4. Setup comparator register (CMR) for setting PWM duty.
5. Setup PWM down-counter register (CNR) for setting PWM period.
6. Setup interrupt enable register (PIER) (option)
7. Setup corresponding GPIO pins as PWM function (enable POE and disable CAPENR) for the corresponding PWM channel.
8. Enable PWM timer start running (Set CHxEN = 1 in PCR)

#### 5.7.4.8 PWM-Timer Re-Start Procedure in Single-shot mode

After PWM waveform generated once in PWM one-shot mode, PWM-Timer will stop automatically. The following procedure is recommended for re-starting PWM single-shot waveform.

1. Setup comparator register (CMR) for setting PWM duty.
2. Setup PWM down-counter register (CNR) for setting PWM period. After setup CNR, PWM wave will be generated.

#### 5.7.4.9 PWM-Timer Stop Procedure

##### Method 1:

Set 16-bit down counter (CNR) as 0, and monitor PDR (current value of 16-bit down-counter). When PDR reaches to 0, disable PWM-Timer (CHxEN in PCR). **(Recommended)**

##### Method 2:

Set 16-bit down counter (CNR) as 0. When interrupt request happened, disable PWM-Timer (CHxEN in PCR). **(Recommended)**

##### Method 3:

Disable PWM-Timer directly ((CHxEN in PCR). **(Not recommended)**

The reason why method 3 is not recommended is that disable CHxEN will immediately stop PWM output signal and lead to change the duty of the PWM output, this may cause damage to the control circuit of motor

## 5.7.4.10 Capture Start Procedure

1. Setup clock source divider select register (CSR)
2. Setup prescaler (PPR)
3. Setup channel enabled, rising/falling interrupt enable and input signal inverter on/off (CCR0, CCR2)
4. Setup auto-reload mode, Edge-aligned type and Stop PWM-timer (PCR)
5. Setup PWM down-counter (CNR)
6. Enable PWM timer start running (Set CHxEN = 1 in PCR)
7. Setup corresponding GPIO pins as capture function (disable POE and enable CAPENR) for the corresponding PWM channel.



## 5.7.5 Register Map

R: read only, W: write only, R/W: both read and write

Register	Offset	R/W	Description	Reset Value
<b>PWMA_BA = 0x4004_0000 (PWM group A)</b>				
<b>PWMB_BA = 0x4014_0000 (PWM group B) (PWM group B only support in NuMicro™ NUC100/NUC120 Medium Density)</b>				
<b>PPR</b>	PWMA_BA+0x00	R/W	PWM Group A Prescaler Register	0x0000_0000
	PWMB_BA+0x00	R/W	PWM Group B Prescaler Register (NuMicro™ NUC100/NUC120 Medium Density Only)	0x0000_0000
<b>CSR</b>	PWMA_BA+0x04	R/W	PWM Group A Clock Source Divider Select Register	0x0000_0000
	PWMB_BA+0x04	R/W	PWM Group B Clock Source Divider Select Register (NuMicro™ NUC100/NUC120 Medium Density Only)	0x0000_0000
<b>PCR</b>	PWMA_BA+0x08	R/W	PWM Group A Control Register	0x0000_0000
	PWMB_BA+0x08	R/W	PWM Group B Control Register (NuMicro™ NUC100/NUC120 Medium Density Only)	0x0000_0000
<b>CNR0</b>	PWMA_BA+0x0C	R/W	PWM Group A Counter Register 0	0x0000_0000
	PWMB_BA+0x0C	R/W	PWM Group B Counter Register 0 (NuMicro™ NUC100/NUC120 Medium Density Only)	0x0000_0000
<b>CMR0</b>	PWMA_BA+0x10	R/W	PWM Group A Comparator Register 0	0x0000_0000
	PWMB_BA+0x10	R/W	PWM Group B Comparator Register 0 (NuMicro™ NUC100/NUC120 Medium Density Only)	0x0000_0000
<b>PDR0</b>	PWMA_BA+0x14	R	PWM Group A Data Register 0	0x0000_0000
	PWMB_BA+0x14	R	PWM Group B Data Register 0 (NuMicro™ NUC100/NUC120 Medium Density Only)	0x0000_0000
<b>CNR1</b>	PWMA_BA+0x18	R/W	PWM Group A Counter Register 1	0x0000_0000
	PWMB_BA+0x18	R/W	PWM Group B Counter Register 1 (NuMicro™ NUC100/NUC120 Medium Density Only)	0x0000_0000
<b>CMR1</b>	PWMA_BA+0x1C	R/W	PWM Group A Comparator Register 1	0x0000_0000
	PWMB_BA+0x1C	R/W	PWM Group B Comparator Register 1 (NuMicro™ NUC100/NUC120 Medium Density Only)	0x0000_0000
<b>PDR1</b>	PWMA_BA+0x20	R	PWM Group A Data Register 1	0x0000_0000
	PWMB_BA+0x20	R	PWM Group B Data Register 1 (NuMicro™ NUC100/NUC120 Medium Density Only)	0x0000_0000



Register	Offset	R/W	Description	Reset Value
<b>CNR2</b>	PWMA_BA+0x24	R/W	PWM Group A Counter Register 2	0x0000_0000
	PWMB_BA+0x24	R/W	PWM Group B Counter Register 2 (NuMicro™ NUC100/NUC120 Medium Density Only)	0x0000_0000
<b>CMR2</b>	PWMA_BA+0x28	R/W	PWM Group A Comparator Register 2	0x0000_0000
	PWMB_BA+0x28	R/W	PWM Group B Comparator Register 2 (NuMicro™ NUC100/NUC120 Medium Density Only)	0x0000_0000
<b>PDR2</b>	PWMA_BA+0x2C	R	PWM Group A Data Register 2	0x0000_0000
	PWMB_BA+0x2C	R	PWM Group B Data Register 2 (NuMicro™ NUC100/NUC120 Medium Density Only)	0x0000_0000
<b>CNR3</b>	PWMA_BA+0x30	R/W	PWM Group A Counter Register 3	0x0000_0000
	PWMB_BA+0x30	R/W	PWM Group B Counter Register 3 (NuMicro™ NUC100/NUC120 Medium Density Only)	0x0000_0000
<b>CMR3</b>	PWMA_BA+0x34	R/W	PWM Group A Comparator Register 3	0x0000_0000
	PWMB_BA+0x34	R/W	PWM Group B Comparator Register 3 (NuMicro™ NUC100/NUC120 Medium Density Only)	0x0000_0000
<b>PDR3</b>	PWMA_BA+0x38	R	PWM Group A Data Register 3	0x0000_0000
	PWMB_BA+0x38	R	PWM Group B Data Register 3 (NuMicro™ NUC100/NUC120 Medium Density Only)	0x0000_0000
<b>PBCR</b>	PWMA_BA+0x3C	R/W	PWM backward compatible Register (NuMicro™ NUC100/NUC120 Low Density Only)	0x0000_0000
<b>PIER</b>	PWMA_BA+0x40	R/W	PWM Group A Interrupt Enable Register	0x0000_0000
	PWMB_BA+0x40	R/W	PWM Group B Interrupt Enable Register (NuMicro™ NUC100/NUC120 Medium Density Only)	0x0000_0000
<b>PIIR</b>	PWMA_BA+0x44	R/W	PWM Group A Interrupt Indication Register	0x0000_0000
	PWMB_BA+0x44	R/W	PWM Group B Interrupt Indication Register (NuMicro™ NUC100/NUC120 Medium Density Only)	0x0000_0000
<b>CCR0</b>	PWMA_BA+0x50	R/W	PWM Group A Capture Control Register 0	0x0000_0000
	PWMB_BA+0x50	R/W	PWM Group B Capture Control Register 0 (NuMicro™ NUC100/NUC120 Medium Density Only)	0x0000_0000
<b>CCR2</b>	PWMA_BA+0x54	R/W	PWM Group A Capture Control Register 2	0x0000_0000
	PWMB_BA+0x54	R/W	PWM Group B Capture Control Register 2 (NuMicro™ NUC100/NUC120 Medium Density Only)	0x0000_0000
<b>CRLR0</b>	PWMA_BA+0x58	R	PWM Group A Capture Rising Latch Register (Channel 0)	0x0000_0000



Register	Offset	R/W	Description	Reset Value
	PWMB_BA+0x58	R	PWM Group B Capture Rising Latch Register (Channel 0) (NuMicro™ NUC100/NUC120 Medium Density Only)	0x0000_0000
<b>CFLR0</b>	PWMA_BA+0x5C	R	PWM Group A Capture Falling Latch Register (Channel 0)	0x0000_0000
	PWMB_BA+0x5C	R	PWM Group B Capture Falling Latch Register (Channel 0) (NuMicro™ NUC100/NUC120 Medium Density Only)	0x0000_0000
<b>CRLR1</b>	PWMA_BA+0x60	R	PWM Group A Capture Rising Latch Register (Channel 1)	0x0000_0000
	PWMB_BA+0x60	R	PWM Group B Capture Rising Latch Register (Channel 1) (NuMicro™ NUC100/NUC120 Medium Density Only)	0x0000_0000
<b>CFLR1</b>	PWMA_BA+0x64	R	PWM Group A Capture Falling Latch Register (Channel 1)	0x0000_0000
	PWMB_BA+0x64	R	PWM Group B Capture Falling Latch Register (Channel 1) (NuMicro™ NUC100/NUC120 Medium Density Only)	0x0000_0000
<b>CRLR2</b>	PWMA_BA+0x68	R	PWM Group A Capture Rising Latch Register (Channel 2)	0x0000_0000
	PWMB_BA+0x68	R	PWM Group B Capture Rising Latch Register (Channel 2) (NuMicro™ NUC100/NUC120 Medium Density Only)	0x0000_0000
<b>CFLR2</b>	PWMA_BA+0x6C	R	PWM Group A Capture Falling Latch Register (Channel 2)	0x0000_0000
	PWMB_BA+0x6C	R	PWM Group B Capture Falling Latch Register (Channel 2) (NuMicro™ NUC100/NUC120 Medium Density Only)	0x0000_0000
<b>CRLR3</b>	PWMA_BA+0x70	R	PWM Group A Capture Rising Latch Register (Channel 3)	0x0000_0000
	PWMB_BA+0x70	R	PWM Group B Capture Rising Latch Register (Channel 3) (NuMicro™ NUC100/NUC120 Medium Density Only)	0x0000_0000
<b>CFLR3</b>	PWMA_BA+0x74	R	PWM Group A Capture Falling Latch Register (Channel 3)	0x0000_0000
	PWMB_BA+0x74	R	PWM Group B Capture Falling Latch Register (Channel 3) (NuMicro™ NUC100/NUC120 Medium Density Only)	0x0000_0000
<b>CAPENR</b>	PWMA_BA+0x78	R/W	PWM Group A Capture Input 0~3 Enable Register	0x0000_0000
	PWMB_BA+0x78	R/W	PWM Group B Capture Input 0~3 Enable Register (NuMicro™ NUC100/NUC120 Medium Density Only)	0x0000_0000
<b>POE</b>	PWMA_BA+0x7C	R/W	PWM Group A Output Enable for channel 0~3	0x0000_0000
	PWMB_BA+0x7C	R/W	PWM Group B Output Enable for channel 0~3 (NuMicro™ NUC100/NUC120 Medium Density Only)	0x0000_0000



5.7.6 Register Description

**PWM Pre-Scale Register (PPR)**

Register	Offset	R/W	Description	Reset Value
PPR	PWMA_BA+0x00	R/W	PWM Group A Pre-scale Register	0x0000_0000
	PWMB_BA+0x00	R/W	PWM Group B Pre-scale Register (NuMicro™ NUC100/NUC120 Medium Density Only)	0x0000_0000

31	30	29	28	27	26	25	24
DZ123							
23	22	21	20	19	18	17	16
DZ101							
15	14	13	12	11	10	9	8
CP23							
7	6	5	4	3	2	1	0
CP01							

Bits	Descriptions	
[31:24]	<b>DZ123</b>	<p><b>Dead Zone Interval for Pair of Channel2 and Channel3</b> (PWM2 and PWM3 pair for PWM group A, PWM6 and PWM7 pair for PWM group B)</p> <p>These 8-bit determine dead zone length.</p> <p>The unit time of dead zone length is received from corresponding CSR bits.</p>
[23:16]	<b>DZ101</b>	<p><b>Dead Zone Interval for Pair of Channel 0 and Channel 1</b> (PWM0 and PWM1 pair for PWM group A, PWM4 and PWM5 pair for PWM group B)</p> <p>These 8-bit determine dead zone length.</p> <p>The unit time of dead zone length is received from corresponding CSR bits.</p>
[15:8]	<b>CP23</b>	<p><b>Clock Prescaler 2</b> (PWM-timer2 /3 for group A and PWM-timer 6 / 7 for group B)</p> <p>Clock input is divided by (CP23 + 1) before it is fed to the corresponding PWM-timer</p> <p>If CP23=0, then the clock prescaler 2 output clock will be stopped. So corresponding PWM-timer will be stopped also.</p>
[7:0]	<b>CP01</b>	<p><b>Clock Prescaler 0</b> (PWM-timer 0 / 1 for group A and PWM-timer 4 / 5 for group B)</p> <p>Clock input is divided by (CP01 + 1) before it is fed to the corresponding PWM-timer</p> <p>If CP01=0, then the clock prescaler 0 output clock will be stopped. So corresponding PWM-timer will be stopped also.</p>



## PWM Clock Source Divider Select Register (CSR)

Register	Offset	R/W	Description	Reset Value
CSR	PWMA_BA+0x04	R/W	PWM Group A Clock Source Divider Select Register	0x0000_0000
	PWMB_BA+0x04	R/W	PWM Group B Clock Source Divider Select Register (NuMicro™ NUC100/NUC120 Medium Density Only)	0x0000_0000

31	30	29	28	27	26	25	24
Reserved							
23	22	21	20	19	18	17	16
Reserved							
15	14	13	12	11	10	9	8
Reserved	CSR3			Reserved	CSR2		
7	6	5	4	3	2	1	0
Reserved	CSR1			Reserved	CSR0		

Bits	Descriptions													
[31:15]	Reserved	Reserved												
[14:12]	CSR3	<b>PWM Timer 3 Clock Source Divider Selection</b> (PWM timer 3 for group A and PWM timer 7 for group B) Select clock source divider for PWM timer 3.												
		<table border="1" style="width: 100%; text-align: center;"> <thead> <tr> <th>CSR3</th> <th>Input clock divided by</th> </tr> </thead> <tbody> <tr> <td>100</td> <td>1</td> </tr> <tr> <td>011</td> <td>16</td> </tr> <tr> <td>010</td> <td>8</td> </tr> <tr> <td>001</td> <td>4</td> </tr> <tr> <td>000</td> <td>2</td> </tr> </tbody> </table>	CSR3	Input clock divided by	100	1	011	16	010	8	001	4	000	2
		CSR3	Input clock divided by											
		100	1											
		011	16											
		010	8											
001	4													
000	2													
[11]	Reserved	Reserved												
[10:8]	CSR2	<b>PWM Timer 2 Clock Source Divider Selection</b> (PWM timer 2 for group A and PWM timer 6 for group B) Select clock source divider for PWM timer 2. (Table is the same as CSR3)												
[7]	Reserved	Reserved												
[6:4]	CSR1	<b>PWM Timer 1 Clock Source Divider Selection</b> (PWM timer 1 for group A and PWM timer 5 for group B)												



Bits	Descriptions	
		Select clock source divider for PWM timer 1. (Table is the same as CSR3)
[3]	<b>Reserved</b>	Reserved
[2:0]	<b>CSR0</b>	<b>PWM Timer 0 Clock Source Divider Selection</b> (PWM timer 0 for group A and PWM timer 4 for group B) Select clock source divider for PWM timer 0. (Table is the same as CSR3)





## PWM Control Register (PCR)

Register	Offset	R/W	Description	Reset Value
PCR	PWMA_BA+0x08	R/W	PWM Group A Control Register (PCR)	0x0000_0000
	PWMB_BA+0x08	R/W	PWM Group B Control Register (PCR) (NuMicro™ NUC100/NUC120 Medium Density Only)	0x0000_0000

31	30	29	28	27	26	25	24
Reserved				CH3MOD	CH3INV	Reserved	CH3EN
23	22	21	20	19	18	17	16
Reserved				CH2MOD	CH2INV	Reserved	CH2EN
15	14	13	12	11	10	9	8
Reserved				CH1MOD	CH1INV	Reserved	CH1EN
7	6	5	4	3	2	1	0
Reserved		DZEN23	DZEN01	CH0MOD	CH0INV	Reserved	CH0EN

Bits	Descriptions	
[31:28]	Reserved	Reserved
[27]	CH3MOD	<b>PWM-Timer 3 Auto-reload/One-Shot Mode</b> (PWM timer 3 for group A and PWM timer 7 for group B) 1 = Auto-reload Mode 0 = One-Shot Mode Note: If there is a transition at this bit, it will cause CNR3 and CMR3 be clear.
[26]	CH3INV	<b>PWM-Timer 3 Output Inverter Enable</b> (PWM timer 3 for group A and PWM timer 7 for group B) 1 = Inverter enable 0 = Inverter disable
[25]	Reserved	Reserved
[24]	CH3EN	<b>PWM-Timer 3 Enable</b> (PWM timer 3 for group A and PWM timer 7 for group B) 1 = Enable corresponding PWM-Timer Start Run 0 = Stop corresponding PWM-Timer Running
[23:20]	Reserved	Reserved
[19]	CH2MOD	<b>PWM-Timer 2 Auto-reload/One-Shot Mode</b> (PWM timer 2 for group A and PWM timer 6 for group B) 1 = Auto-reload Mode 0 = One-Shot Mode



Bits	Descriptions	
		Note: If there is a transition at this bit, it will cause CNR2 and CMR2 be clear.
[18]	<b>CH2INV</b>	<b>PWM-Timer 2 Output Inverter Enable</b> (PWM timer 2 for group A and PWM timer 6 for group B) 1 = Inverter enable 0 = Inverter disable
[17]	<b>Reserved</b>	Reserved
[16]	<b>CH2EN</b>	<b>PWM-Timer 2 Enable</b> (PWM timer 2 for group A and PWM timer 6 for group B) 1 = Enable corresponding PWM-Timer Start Run 0 = Stop corresponding PWM-Timer Running
[15:12]	<b>Reserved</b>	Reserved
[11]	<b>CH1MOD</b>	<b>PWM-Timer 1 Auto-reload/One-Shot Mode</b> (PWM timer 1 for group A and PWM timer 5 for group B) 1 = Auto-load Mode 0 = One-Shot Mode  Note: If there is a transition at this bit, it will cause CNR1 and CMR1 be clear.
[10]	<b>CH1INV</b>	<b>PWM-Timer 1 Output Inverter Enable</b> (PWM timer 1 for group A and PWM timer 5 for group B) 1 = Inverter enable 0 = Inverter disable
[9]	<b>Reserved</b>	Reserved
[8]	<b>CH1EN</b>	<b>PWM-Timer 1 Enable</b> (PWM timer 1 for group A and PWM timer 5 for group B) 1 = Enable corresponding PWM-Timer Start Run 0 = Stop corresponding PWM-Timer Running
[7:6]	<b>Reserved</b>	Reserved
[5]	<b>DZEN23</b>	<b>Dead-Zone 2 Generator Enable</b> (PWM2 and PWM3 pair for PWM group A, PWM6 and PWM7 pair for PWM group B) 1 = Enable 0 = Disable  Note: When Dead-Zone Generator is enabled, the pair of PWM2 and PWM3 becomes a complementary pair for PWM group A and the pair of PWM6 and PWM7 becomes a complementary pair for PWM group B.
[4]	<b>DZEN01</b>	<b>Dead-Zone 0 Generator Enable</b> (PWM0 and PWM1 pair for PWM group A, PWM4 and PWM5 pair for PWM group B) 1 = Enable 0 = Disable  Note: When Dead-Zone Generator is enabled, the pair of PWM0 and PWM1 becomes a complementary pair for PWM group A and the pair of PWM4 and PWM5 becomes a complementary pair for PWM group B.
[3]	<b>CH0MOD</b>	<b>PWM-Timer 0 Auto-reload/One-Shot Mode</b> (PWM timer 0 for group A and PWM timer 4 for group B) 1 = Auto-reload Mode



Bits	Descriptions	
		0 = One-Shot Mode Note: If there is a transition at this bit, it will cause CNR0 and CMR0 be clear.
[2]	<b>CH0INV</b>	<b>PWM-Timer 0 Output Inverter Enable</b> (PWM timer 0 for group A and PWM timer 4 for group B) 1 = Inverter enable 0 = Inverter disable
[1]	<b>Reserved</b>	Reserved
[0]	<b>CH0EN</b>	<b>PWM-Timer 0 Enable</b> (PWM timer 0 for group A and PWM timer 4 for group B) 1 = Enable corresponding PWM-Timer Start Run 0 = Stop corresponding PWM-Timer Running



## PWM Counter Register 3-0 (CNR3-0)

Register	Offset	R/W	Description	Reset Value
<b>CNR0</b>	PWMA_BA+0x0C	R/W	PWM Group A Counter Register 0	0x0000_0000
	PWMB_BA+0x0C	R/W	PWM Group B Counter Register 0 (NuMicro™ NUC100/NUC120 Medium Density Only)	0x0000_0000
<b>CNR1</b>	PWMA_BA+0x18	R/W	PWM Group A Counter Register 1	0x0000_0000
	PWMB_BA+0x18	R/W	PWM Group B Counter Register 1 (NuMicro™ NUC100/NUC120 Medium Density Only)	0x0000_0000
<b>CNR2</b>	PWMA_BA+0x24	R/W	PWM Group A Counter Register 2	0x0000_0000
	PWMB_BA+0x24	R/W	PWM Group B Counter Register 2 (NuMicro™ NUC100/NUC120 Medium Density Only)	0x0000_0000
<b>CNR3</b>	PWMA_BA+0x30	R/W	PWM Group A Counter Register 3	0x0000_0000
	PWMB_BA+0x30	R/W	PWM Group B Counter Register 3 (NuMicro™ NUC100/NUC120 Medium Density Only)	0x0000_0000

31	30	29	28	27	26	25	24
Reserved							
23	22	21	20	19	18	17	16
Reserved							
15	14	13	12	11	10	9	8
CNRx [15:8]							
7	6	5	4	3	2	1	0
CNRx [7:0]							

Bits	Descriptions
[31:16]	<b>Reserved</b> Reserved
[15:0]	<p><b>CNRx</b></p> <p><b>PWM Timer Loaded Value</b></p> <p>CNR determines the PWM period.</p> <ul style="list-style-type: none"> <li>● PWM frequency = <math>PWM_{xy\_CLK} / [(prescale+1) * (clock\ divider) * (CNR+1)]</math>; where xy, could be 01, 23, 45 or 67, depends on selected PWM channel.</li> <li>● Duty ratio = <math>(CMR+1) / (CNR+1)</math>.</li> <li>● <math>CMR \geq CNR</math>: PWM output is always high.</li> <li>● <math>CMR &lt; CNR</math>: PWM low width = (CNR-CMR) unit; PWM high width = (CMR+1) unit.</li> <li>● <math>CMR = 0</math>: PWM low width = (CNR) unit; PWM high width = 1 unit (Unit = one PWM clock cycle)</li> </ul> <p>Note: Any write to CNR will take effect in next PWM cycle.</p>



### PWM Comparator Register 3-0 (CMR3-0)

Register	Offset	R/W	Description	Reset Value
<b>CMR0</b>	PWMA_BA+0x10	R/W	PWM Group A Comparator Register 0	0x0000_0000
	PWMB_BA+0x10	R/W	PWM Group B Comparator Register 0 (NuMicro™ NUC100/NUC120 Medium Density Only)	0x0000_0000
<b>CMR1</b>	PWMA_BA+0x1C	R/W	PWM Group A Comparator Register 1	0x0000_0000
	PWMB_BA+0x1C	R/W	PWM Group B Comparator Register 1 (NuMicro™ NUC100/NUC120 Medium Density Only)	0x0000_0000
<b>CMR2</b>	PWMA_BA+0x28	R/W	PWM Group A Comparator Register 2	0x0000_0000
	PWMB_BA+0x28	R/W	PWM Group B Comparator Register 2 (NuMicro™ NUC100/NUC120 Medium Density Only)	0x0000_0000
<b>CMR3</b>	PWMA_BA+0x34	R/W	PWM Group A Comparator Register 3	0x0000_0000
	PWMB_BA+0x34	R/W	PWM Group B Comparator Register 3 (NuMicro™ NUC100/NUC120 Medium Density Only)	0x0000_0000

31	30	29	28	27	26	25	24
<b>Reserved</b>							
23	22	21	20	19	18	17	16
<b>Reserved</b>							
15	14	13	12	11	10	9	8
<b>CMRx [15:8]</b>							
7	6	5	4	3	2	1	0
<b>CMRx [7:0]</b>							

Bits	Descriptions
[31:16]	<b>Reserved</b>
[15:0]	<p><b>Reserved</b></p> <p><b>PWM Comparator Register</b> CMR determines the PWM duty.</p> <ul style="list-style-type: none"> <li>● PWM frequency = <math>PWM_{xy\_CLK} / [(prescale+1) * (clock\ divider) * (CNR+1)]</math>; where xy, could be 01, 23, 45 or 67, depends on selected PWM channel.</li> <li>● Duty ratio = <math>(CMR+1) / (CNR+1)</math>.</li> <li>● <math>CMR \geq CNR</math>: PWM output is always high.</li> <li>● <math>CMR &lt; CNR</math>: PWM low width = <math>(CNR-CMR)</math> unit; PWM high width = <math>(CMR+1)</math> unit.</li> <li>● <math>CMR = 0</math>: PWM low width = <math>(CNR)</math> unit; PWM high width = 1 unit</li> </ul> <p>(Unit = one PWM clock cycle) Note: Any write to CMR will take effect in next PWM cycle.</p>



### PWM Data Register 3-0 (PDR 3-0)

Register	Offset	R/W	Description	Reset Value
<b>PDR0</b>	PWMA_BA+0x14	R	PWM Group A Data Register 0	0x0000_0000
	PWMB_BA+0x14	R	PWM Group B Data Register 0 (NuMicro™ NUC100/NUC120 Medium Density Only)	0x0000_0000
<b>PDR1</b>	PWMA_BA+0x20	R	PWM Group A Data Register 1	0x0000_0000
	PWMB_BA+0x20	R	PWM Group B Data Register 1 (NuMicro™ NUC100/NUC120 Medium Density Only)	0x0000_0000
<b>PDR2</b>	PWMA_BA+0x2C	R	PWM Group A Data Register 2	0x0000_0000
	PWMB_BA+0x2C	R	PWM Group B Data Register 2 (NuMicro™ NUC100/NUC120 Medium Density Only)	0x0000_0000
<b>PDR3</b>	PWMA_BA+0x38	R	PWM Group A Data Register 3	0x0000_0000
	PWMB_BA+0x38	R	PWM Group B Data Register 3 (NuMicro™ NUC100/NUC120 Medium Density Only)	0x0000_0000

31	30	29	28	27	26	25	24
<b>Reserved</b>							
23	22	21	20	19	18	17	16
<b>Reserved</b>							
15	14	13	12	11	10	9	8
<b>PDR[15:8]</b>							
7	6	5	4	3	2	1	0
<b>PDR[7:0]</b>							

Bits	Descriptions	
[31:16]	<b>Reserved</b>	Reserved
[15:0]	<b>PDRx</b>	<b>PWM Data Register</b> User can monitor PDR to know the current value in 16-bit down counter.



### PWM Backward Compatible Register (NuMicro™ NUC100/NUC120 Low Density Only)

Register	Offset	R/W	Description	Reset Value
PBCR	PWMA_BA+0x3C	R/W	PWM backward compatible Register	0x0000_0000

31	30	29	28	27	26	25	24
Reserved							
23	22	21	20	19	18	17	16
Reserved							
15	14	13	12	11	10	9	8
Reserved							
7	6	5	4	3	2	1	0
Reserved							BCn

Bits	Descriptions	
[31:1]	Reserved	Reserved
[0]	BCn	<b>PWM Backward Compatible Register</b> 0 = configure write 0 to clear CFLRI0~3 and CRLRI0~3. 1 = configure write 1 to clear CFLRI0~3 and CRLRI0~3. Please reference CCR0/CCR2 register bit 6, 7, 22, 23 description



## PWM Interrupt Enable Register (PIER)

Register	Offset	R/W	Description	Reset Value
PIER	PWMA_BA+0x40	R/W	PWM Group A Interrupt Enable Register	0x0000_0000
	PWMB_BA+0x40	R/W	PWM Group B Interrupt Enable Register (NuMicro™ NUC100/NUC120 Medium Density Only)	0x0000_0000

31	30	29	28	27	26	25	24
Reserved							
23	22	21	20	19	18	17	16
Reserved							
15	14	13	12	11	10	9	8
Reserved							
7	6	5	4	3	2	1	0
Reserved				PWMIE3	PWMIE2	PWMIE1	PWMIE0

Bits	Descriptions	
[31:4]	Reserved	Reserved
[3]	PWMIE3	<b>PWM channel 3 Interrupt Enable</b> 1 = Enable 0 = Disable
[2]	PWMIE2	<b>PWM channel 2 Interrupt Enable</b> 1 = Enable 0 = Disable
[1]	PWMIE1	<b>PWM channel 1 Interrupt Enable</b> 1 = Enable 0 = Disable
[0]	PWMIE0	<b>PWM channel 0 Interrupt Enable</b> 1 = Enable 0 = Disable





## PWM Interrupt Indication Register (PIIR)

Register	Offset	R/W	Description	Reset Value
PIIR	PWMA_BA+0x44	R/W	PWM Group A Interrupt Indication Register	0x0000_0000
	PWMB_BA+0x44	R/W	PWM Group B Interrupt Indication Register (NuMicro™ NUC100/NUC120 Medium Density Only)	0x0000_0000

31	30	29	28	27	26	25	24
Reserved							
23	22	21	20	19	18	17	16
Reserved							
15	14	13	12	11	10	9	8
Reserved							
7	6	5	4	3	2	1	0
Reserved				PWMIF3	PWMIF2	PWMIF1	PWMIF0

Bits	Descriptions	
[31:4]	Reserved	Reserved
[3]	<b>PWMIF3</b>	<b>PWM channel 3 Interrupt Status</b> This bit is set by hardware when PWM3 down counter reaches zero if PWM3 interrupt enable bit (PWMIE3) is 1, software can write 1 to clear this bit to zero
[2]	<b>PWMIF2</b>	<b>PWM channel 2 Interrupt Status</b> This bit is set by hardware when PWM2 down counter reaches zero if PWM3 interrupt enable bit (PWMIE2) is 1, software can write 1 to clear this bit to zero
[1]	<b>PWMIF1</b>	<b>PWM channel 1 Interrupt Status</b> This bit is set by hardware when PWM1 down counter reaches zero if PWM3 interrupt enable bit (PWMIE1) is 1, software can write 1 to clear this bit to zero
[0]	<b>PWMIF0</b>	<b>PWM channel 0 Interrupt Status</b> This bit is set by hardware when PWM0 down counter reaches zero if PWM3 interrupt enable bit (PWMIE0) is 1, software can write 1 to clear this bit to zero

Note: User can clear each interrupt flag by writing 1 to corresponding bit in PIIR.



## Capture Control Register (CCR0)

Register	Offset	R/W	Description	Reset Value
CCR0	PWMA_BA+0x50	R/W	PWM Group A Capture Control Register	0x0000_0000
	PWMB_BA+0x50	R/W	PWM Group B Capture Control Register (NuMicro™ NUC100/NUC120 Medium Density Only)	0x0000_0000

31	30	29	28	27	26	25	24
Reserved							
23	22	21	20	19	18	17	16
CFLR1	CRLR1	Reserved	CAPIF1	CAPCH1EN	CFL_IE1	CRL_IE1	INV1
15	14	13	12	11	10	9	8
Reserved							
7	6	5	4	3	2	1	0
CFLR0	CRLR0	Reserved	CAPIF0	CAPCH0EN	CFL_IE0	CRL_IE0	INV0

Bits	Descriptions	
[31:24]	Reserved	Reserved
[23]	CFLR1	<p><b>CFLR1 Latched Indicator Bit</b></p> <p>When PWM group input channel 1 has a falling transition, CFLR1 was latched with the value of PWM down-counter and this bit is set by hardware.</p> <p>In NuMicro™ NUC100/NUC120 Medium Density, software can write 0 to clear this bit to zero.</p> <p>In NuMicro™ NUC100/NUC120 Low Density, software can write 0 to clear this bit to zero if BCn bit is 0, and can Write 1 to clear this bit to zero if BCn bit is 1.</p>
[22]	CRLR1	<p><b>CRLR1 Latched Indicator Bit</b></p> <p>When PWM group input channel 1 has a rising transition, CRLR1 was latched with the value of PWM down-counter and this bit is set by hardware.</p> <p>In NuMicro™ NUC100/NUC120 Medium Density, software can write 0 to clear this bit to zero.</p> <p>In NuMicro™ NUC100/NUC120 Low Density, software can write 0 to clear this bit to zero if BCn bit is 0, and can Write 1 to clear this bit to zero if BCn bit is 1.</p>
[5]	Reserved	Reserved
[20]	CAPIF1	<p><b>Channel 1 Capture Interrupt Indication Flag</b></p> <p>If PWM group channel 1 rising latch interrupt is enabled (CRL_IE1=1), a rising transition occurs at PWM group channel 1 will result in CAPIF1 to high; Similarly, a falling transition will cause CAPIF1 to be set high if PWM group channel 1 falling latch interrupt is enabled (CFL_IE1=1).</p> <p>Write 1 to clear this bit to zero</p>



Bits	Descriptions	
[19]	<b>CAPCH1EN</b>	<p><b>Channel 1 Capture Function Enable</b></p> <p>1 = Enable capture function on PWM group channel 1 0 = Disable capture function on PWM group channel 1</p> <p>When Enable, Capture latched the PWM-counter and saved to CRLR (Rising latch) and CFLR (Falling latch).</p> <p>When Disable, Capture does not update CRLR and CFLR, and disable PWM group channel 1 Interrupt.</p>
[18]	<b>CFL_IE1</b>	<p><b>Channel 1 Falling Latch Interrupt Enable</b></p> <p>1 = Enable falling latch interrupt 0 = Disable falling latch interrupt</p> <p>When Enable, if Capture detects PWM group channel 1 has falling transition, Capture issues an Interrupt.</p>
[17]	<b>CRL_IE1</b>	<p><b>Channel 1 Rising Latch Interrupt Enable</b></p> <p>1 = Enable rising latch interrupt 0 = Disable rising latch interrupt</p> <p>When Enable, if Capture detects PWM group channel 1 has rising transition, Capture issues an Interrupt.</p>
[16]	<b>INV1</b>	<p><b>Channel 1 Inverter Enable</b></p> <p>1 = Inverter enable. Reverse the input signal from GPIO before fed to Capture timer 0 = Inverter disable</p>
[15:8]	<b>Reserved</b>	Reserved
[7]	<b>CFLR0</b>	<p><b>CFLR0 Latched Indicator Bit</b></p> <p>When PWM group input channel 0 has a falling transition, CFLR0 was latched with the value of PWM down-counter and this bit is set by hardware.</p> <p>In NuMicro™ NUC100/NUC120 Medium Density, software can write 0 to clear this bit to zero.</p> <p>In NuMicro™ NUC100/NUC120 Low Density, software can write 0 to clear this bit to zero if BCn bit is 0, and can Write 1 to clear this bit to zero if BCn bit is 1.</p>
[6]	<b>CRLR0</b>	<p><b>CRLR0 Latched Indicator Bit</b></p> <p>When PWM group input channel 0 has a rising transition, CRLR0 was latched with the value of PWM down-counter and this bit is set by hardware.</p> <p>In NuMicro™ NUC100/NUC120 Medium Density, software can write 0 to clear this bit to zero.</p> <p>In NuMicro™ NUC100/NUC120 Low Density, software can write 0 to clear this bit to zero if BCn bit is 0, and can Write 1 to clear this bit to zero if BCn bit is 1.</p>
[5]	<b>Reserved</b>	Reserved
[4]	<b>CAPIF0</b>	<p><b>Channel 0 Capture Interrupt Indication Flag</b></p> <p>If PWM group channel 0 rising latch interrupt is enabled (CRL_IE0=1), a rising transition occurs at PWM group channel 0 will result in CAPIF0 to high; Similarly, a falling transition will cause CAPIF0 to be set high if PWM group channel 0 falling latch interrupt is enabled (CFL_IE0=1).</p> <p>Write 1 to clear this bit to zero</p>



Bits	Descriptions	
[3]	<b>CAPCH0EN</b>	<p><b>Channel 0 Capture Function Enable</b></p> <p>1 = Enable capture function on PWM group channel 0. 0 = Disable capture function on PWM group channel 0</p> <p>When Enable, Capture latched the PWM-counter value and saved to CRLR (Rising latch) and CFLR (Falling latch).</p> <p>When Disable, Capture does not update CRLR and CFLR, and disable PWM group channel 0 Interrupt.</p>
[2]	<b>CFL_IE0</b>	<p><b>Channel 0 Falling Latch Interrupt Enable</b></p> <p>1 = Enable falling latch interrupt 0 = Disable falling latch interrupt</p> <p>When Enable, if Capture detects PWM group channel 0 has falling transition, Capture issues an Interrupt.</p>
[1]	<b>CRL_IE0</b>	<p><b>Channel 0 Rising Latch Interrupt Enable</b></p> <p>1 = Enable rising latch interrupt 0 = Disable rising latch interrupt</p> <p>When Enable, if Capture detects PWM group channel 0 has rising transition, Capture issues an Interrupt.</p>
[0]	<b>INVO</b>	<p><b>Channel 0 Inverter Enable</b></p> <p>1 = Inverter enable. Reverse the input signal from GPIO before fed to Capture timer 0 = Inverter disable</p>



## Capture Control Register (CCR2)

Register	Offset	R/W	Description	Reset Value
CCR2	PWMA_BA+0x54	R/W	PWM Group A Capture Control Register	0x0000_0000
	PWMB_BA+0x54	R/W	PWM Group B Capture Control Register (NuMicro™ NUC100/NUC120 Medium Density Only)	0x0000_0000

31	30	29	28	27	26	25	24
Reserved							
23	22	21	20	19	18	17	16
CFLRI3	CRLRI3	Reserved	CAPIF3	CAPCH3EN	CFL_IE3	CRL_IE3	INV3
15	14	13	12	11	10	9	8
Reserved							
7	6	5	4	3	2	1	0
CFLRI2	CRLRI2	Reserved	CAPIF2	CAPCH2EN	CFL_IE2	CRL_IE2	INV2

Bits	Descriptions	
[31:24]	Reserved	Reserved
[23]	CFLRI3	<p><b>CFLR3 Latched Indicator Bit</b></p> <p>When PWM group input channel 3 has a falling transition, CFLR3 was latched with the value of PWM down-counter and this bit is set by hardware.</p> <p>In NuMicro™ NUC100/NUC120 Medium Density, software can write 0 to clear this bit to zero.</p> <p>In NuMicro™ NUC100/NUC120 Low Density, software can write 0 to clear this bit to zero if BCn bit is 0, and can Write 1 to clear this bit to zero if BCn bit is 1.</p>
[22]	CRLRI3	<p><b>CRLR3 Latched Indicator Bit</b></p> <p>When PWM group input channel 3 has a rising transition, CRLR3 was latched with the value of PWM down-counter and this bit is set by hardware.</p> <p>In NuMicro™ NUC100/NUC120 Medium Density, software can write 0 to clear this bit to zero.</p> <p>In NuMicro™ NUC100/NUC120 Low Density, software can write 0 to clear this bit to zero if BCn bit is 0, and can Write 1 to clear this bit to zero if BCn bit is 1.</p>
[21]	Reserved	Reserved
[20]	CAPIF3	<p><b>Channel 3 Capture Interrupt Indication Flag</b></p> <p>If PWM group channel 3 rising latch interrupt is enabled (CRL_IE3=1), a rising transition occurs at PWM group channel 3 will result in CAPIF3 to high; Similarly, a falling transition will cause CAPIF3 to be set high if PWM group channel 3 falling latch interrupt is enabled (CFL_IE3=1).</p> <p>Write 1 to clear this bit to zero</p>
[19]	CAPCH3EN	<b>Channel 3 Capture Function Enable</b>



Bits	Descriptions	
		<p>1 = Enable capture function on PWM group channel 3</p> <p>0 = Disable capture function on PWM group channel 3</p> <p>When Enable, Capture latched the PWM-counter and saved to CRLR (Rising latch) and CFLR (Falling latch).</p> <p>When Disable, Capture does not update CRLR and CFLR, and disable PWM group channel 3 Interrupt.</p>
[18]	<b>CFL_IE3</b>	<p><b>Channel 3 Falling Latch Interrupt Enable</b></p> <p>1 = Enable falling latch interrupt</p> <p>0 = Disable falling latch interrupt</p> <p>When Enable, if Capture detects PWM group channel 3 has falling transition, Capture issues an Interrupt.</p>
[17]	<b>CRL_IE3</b>	<p><b>Channel 3 Rising Latch Interrupt Enable</b></p> <p>1 = Enable rising latch interrupt</p> <p>0 = Disable rising latch interrupt</p> <p>When Enable, if Capture detects PWM group channel 3 has rising transition, Capture issues an Interrupt.</p>
[16]	<b>INV3</b>	<p><b>Channel 3 Inverter Enable</b></p> <p>1 = Inverter enable. Reverse the input signal from GPIO before fed to Capture timer</p> <p>0 = Inverter disable</p>
[15:8]	<b>Reserved</b>	Reserved
[7]	<b>CFLRI2</b>	<p><b>CFLR2 Latched Indicator Bit</b></p> <p>When PWM group input channel 2 has a falling transition, CFLR2 was latched with the value of PWM down-counter and this bit is set by hardware.</p> <p>In NuMicro™ NUC100/NUC120 Medium Density, software can write 0 to clear this bit to zero.</p> <p>In NuMicro™ NUC100/NUC120 Low Density, software can write 0 to clear this bit to zero if BCn bit is 0, and can Write 1 to clear this bit to zero if BCn bit is 1.</p>
[6]	<b>CRLRI2</b>	<p><b>CRLR2 Latched Indicator Bit</b></p> <p>When PWM group input channel 2 has a rising transition, CRLR2 was latched with the value of PWM down-counter and this bit is set by hardware.</p> <p>In NuMicro™ NUC100/NUC120 Medium Density, software can write 0 to clear this bit to zero.</p> <p>In NuMicro™ NUC100/NUC120 Low Density, software can write 0 to clear this bit to zero if BCn bit is 0, and can Write 1 to clear this bit to zero if BCn bit is 1.</p>
[5]	<b>Reserved</b>	Reserved
[4]	<b>CAPIF2</b>	<p><b>Channel 2 Capture Interrupt Indication Flag</b></p> <p>If PWM group channel 2 rising latch interrupt is enabled (CRL_IE2=1), a rising transition occurs at PWM group channel 2 will result in CAPIF2 to high; Similarly, a falling transition will cause CAPIF2 to be set high if PWM group channel 2 falling latch interrupt is enabled (CFL_IE2=1).</p> <p>Write 1 to clear this bit to zero</p>
[3]	<b>CAPCH2EN</b>	<b>Channel 2 Capture Function Enable</b>



Bits	Descriptions	
		1 = Enable capture function on PWM group channel 2 0 = Disable capture function on PWM group channel 2  When Enable, Capture latched the PWM-counter value and saved to CRLR (Rising latch) and CFLR (Falling latch).  When Disable, Capture does not update CRLR and CFLR, and disable PWM group channel 2 Interrupt.
[2]	<b>CFL_IE2</b>	<b>Channel 2 Falling Latch Interrupt Enable</b> 1 = Enable falling latch interrupt 0 = Disable falling latch interrupt  When Enable, if Capture detects PWM group channel 2 has falling transition, Capture issues an Interrupt.
[1]	<b>CRL_IE2</b>	<b>Channel 2 Rising Latch Interrupt Enable</b> 1 = Enable rising latch interrupt 0 = Disable rising latch interrupt  When Enable, if Capture detects PWM group channel 2 has rising transition, Capture issues an Interrupt.
[0]	<b>INV2</b>	<b>Channel 2 Inverter Enable</b> 1 = Inverter enable. Reverse the input signal from GPIO before fed to Capture timer 0 = Inverter disable



### Capture Rising Latch Register3-0 (CRLR3-0)

Register	Offset	R/W	Description	Reset Value
CRLR0	PWMA_BA+0x58	R	PWM Group A Capture Rising Latch Register (channel 0)	0x0000_0000
	PWMB_BA+0x58	R	PWM Group B Capture Rising Latch Register (channel 0) (NuMicro™ NUC100/NUC120 Medium Density Only)	0x0000_0000
CRLR1	PWMA_BA+0x60	R	PWM Group A Capture Rising Latch Register (channel 1)	0x0000_0000
	PWMB_BA+0x60	R	PWM Group B Capture Rising Latch Register (channel 1) (NuMicro™ NUC100/NUC120 Medium Density Only)	0x0000_0000
CRLR2	PWMA_BA+0x68	R	PWM Group A Capture Rising Latch Register (channel 2)	0x0000_0000
	PWMB_BA+0x68	R	PWM Group B Capture Rising Latch Register (channel 2) (NuMicro™ NUC100/NUC120 Medium Density Only)	0x0000_0000
CRLR3	PWMA_BA+0x70	R	PWM Group A Capture Rising Latch Register (channel 3)	0x0000_0000
	PWMB_BA+0x70	R	PWM Group B Capture Rising Latch Register (channel 3) (NuMicro™ NUC100/NUC120 Medium Density Only)	0x0000_0000

31	30	29	28	27	26	25	24
Reserved							
23	22	21	20	19	18	17	16
Reserved							
15	14	13	12	11	10	9	8
CRLRx [15:8]							
7	6	5	4	3	2	1	0
CRLRx [7:0]							

Bits	Descriptions	
[31:16]	Reserved	Reserved
[15:0]	CRLRx	<b>Capture Rising Latch Register</b> Latch the PWM counter when Channel 0/1/2/3 has rising transition.





## Capture Falling Latch Register3-0 (CFLR3-0)

Register	Offset	R/W	Description	Reset Value
<b>CFLR0</b>	PWMA_BA+0x5C	R	PWM Group A Capture Falling Latch Register (channel 0)	0x0000_0000
	PWMB_BA+0x5C	R	PWM Group B Capture Falling Latch Register (channel 0) (NuMicro™ NUC100/NUC120 Medium Density Only)	0x0000_0000
<b>CFLR1</b>	PWMA_BA+0x64	R	PWM Group A Capture Falling Latch Register (channel 1)	0x0000_0000
	PWMB_BA+0x64	R	PWM Group B Capture Falling Latch Register (channel 1) (NuMicro™ NUC100/NUC120 Medium Density Only)	0x0000_0000
<b>CFLR2</b>	PWMA_BA+0x6C	R	PWM Group A Capture Falling Latch Register (channel 2)	0x0000_0000
	PWMB_BA+0x6C	R	PWM Group B Capture Falling Latch Register (channel 2) (NuMicro™ NUC100/NUC120 Medium Density Only)	0x0000_0000
<b>CFLR3</b>	PWMA_BA+0x74	R	PWM Group A Capture Falling Latch Register (channel 3)	0x0000_0000
	PWMB_BA+0x74	R	PWM Group B Capture Falling Latch Register (channel 3) (NuMicro™ NUC100/NUC120 Medium Density Only)	0x0000_0000

31	30	29	28	27	26	25	24
<b>Reserved</b>							
23	22	21	20	19	18	17	16
<b>Reserved</b>							
15	14	13	12	11	10	9	8
<b>CFLRx [15:8]</b>							
7	6	5	4	3	2	1	0
<b>CFLRx [7:0]</b>							

Bits	Descriptions	
[31:16]	<b>Reserved</b>	Reserved
[15:0]	<b>CFLRx</b>	<b>Capture Falling Latch Register</b> Latch the PWM counter when Channel 0/1/2/3 has Falling transition.



## Capture Input Enable Register (CAPENR)

Register	Offset	R/W	Description	Reset Value
CAPENR	PWMA_BA+0x78	R/W	PWM Group A Capture Input 0~3 Enable Register	0x0000_0000
	PWMB_BA+0x78	R/W	PWM Group B Capture Input 0~3 Enable Register (NuMicro™ NUC100/NUC120 Medium Density Only)	0x0000_0000

31	30	29	28	27	26	25	24
Reserved							
23	22	21	20	19	18	17	16
Reserved							
15	14	13	12	11	10	9	8
Reserved							
7	6	5	4	3	2	1	0
Reserved				CINEN3	CINEN2	CINEN1	CINEN0

Bits	Descriptions	
[31:4]	Reserved	Reserved
[3]	<b>CINEN3</b>	<p><b>Channel 3 Capture Input Enable</b></p> <p>1 = PWM Channel 3 capture input path is enabled. The PWM channel 3 capture function's input comes from correlative multifunction pin if GPIO multi-function is set as PWM3.</p> <p>0 = PWM Channel 3 capture input path is disabled. The PWM channel 3 capture function's input is always saw as 0.</p>
[2]	<b>CINEN2</b>	<p><b>Channel 2 Capture Input Enable</b></p> <p>1 = PWM Channel 2 capture input path is enabled. The PWM channel 2 capture function's input comes from correlative multifunction pin if GPIO multi-function is set as PWM2.</p> <p>0 = PWM Channel 2 capture input path is disabled. The PWM channel 2 capture function's input is always saw as 0.</p>
[1]	<b>CINEN1</b>	<p><b>Channel 1 Capture Input Enable</b></p> <p>1 = PWM Channel 1 capture input path is enabled. The PWM channel 1 capture function's input comes from correlative multifunction pin if GPIO multi-function is set as PWM1.</p> <p>0 = PWM Channel 1 capture input path is disabled. The PWM channel 1 capture function's input is always saw as 0.</p>
[0]	<b>CINEN0</b>	<p><b>Channel 0 Capture Input Enable</b></p> <p>1 = PWM Channel 0 capture input path is enabled. The PWM channel 0 capture function's input comes from correlative multifunction pin if GPIO multi-function is set as PWM0.</p> <p>0 = PWM Channel 0 capture input path is disabled. The PWM channel 0 capture function's input is always saw as 0.</p>



## PWM Output Enable Register (POE)

Register	Offset	R/W	Description	Reset Value
POE	PWMA_BA+0x7C	R/W	PWM Group A Output Enable Register for channel 0~3	0x0000_0000
	PWMB_BA+0x7C	R/W	PWM Group B Output Enable Register for channel 0~3 (NuMicro™ NUC100/NUC120 Medium Density Only)	0x0000_0000

31	30	29	28	27	26	25	24
Reserved							
23	22	21	20	19	18	17	16
Reserved							
15	14	13	12	11	10	9	8
Reserved							
7	6	5	4	3	2	1	0
Reserved				POE3	POE2	POE1	POE0

Bits	Descriptions
[3]	<p><b>POE3</b></p> <p><b>Channel 3 Output Enable Register</b>                      1 = Enable PWM channel 3 output to pin                      0 = Disable PWM channel 3 output to pin                      Note: The corresponding GPIO pin also must be switched to PWM function</p>
[2]	<p><b>POE2</b></p> <p><b>Channel 2 Output Enable Register</b>                      1 = Enable PWM channel 2 output to pin                      0 = Disable PWM channel 2 output to pin                      Note: The corresponding GPIO pin also must be switched to PWM function</p>
[1]	<p><b>POE1</b></p> <p><b>Channel 1 Output Enable Register</b>                      1 = Enable PWM channel 1 output to pin                      0 = Disable PWM channel 1 output to pin                      Note: The corresponding GPIO pin also must be switched to PWM function</p>
[0]	<p><b>POE0</b></p> <p><b>Channel 0 Output Enable Register</b>                      1 = Enable PWM channel 0 output to pin                      0 = Disable PWM channel 0 output to pin                      Note: The corresponding GPIO pin also must be switched to PWM function</p>



## 5.8 Real Time Clock (RTC)

### 5.8.1 Overview

Real Time Clock (RTC) controller provides user the real time and calendar message. The clock source of RTC is from an external 32.768 kHz low speed crystal connected at pins X32I and X32O (reference to pin descriptions) or from an external 32.768 kHz low speed oscillator output fed at pin X32I. The RTC controller provides the time message (second, minute, hour) in Time Loading Register (TLR) as well as calendar message (day, month, year) in Calendar Loading Register (CLR). The data message is expressed in BCD format. It also offers alarm function that user can preset the alarm time in Time Alarm Register (TAR) and alarm calendar in Calendar Alarm Register (CAR).

The RTC controller supports periodic Time Tick and Alarm Match interrupts. The periodic interrupt has 8 period options 1/128, 1/64, 1/32, 1/16, 1/8, 1/4, 1/2 and 1 second which are selected by TTR (TTR[2:0]). When RTC counter in TLR and CLR is equal to alarm setting time registers TAR and CAR, the alarm interrupt flag (RIIR.AIF) is set and the alarm interrupt is requested if the alarm interrupt is enabled (RIER.AIER=1). Both RTC Time Tick and Alarm Match can cause chip wake-up from power down mode if wake-up function is enabled (TWKE (TTR[3])=1).

### 5.8.2 Features

- There is a time counter (second, minute, hour) and calendar counter (day, month, year) for user to check the time
- Alarm register (second, minute, hour, day, month, year)
- 12-hour or 24-hour mode is selectable
- Leap year compensation automatically
- Day of week counter
- Frequency compensate register (FCR)
- All time and calendar message is expressed in BCD code
- Support periodic time tick interrupt with 8 period options 1/128, 1/64, 1/32, 1/16, 1/8, 1/4, 1/2 and 1 second
- Support RTC Time Tick and Alarm Match interrupt
- Support wake-up chip from power down mode

5.8.3 Block Diagram

The block diagram of Real Time Clock is depicted as following:

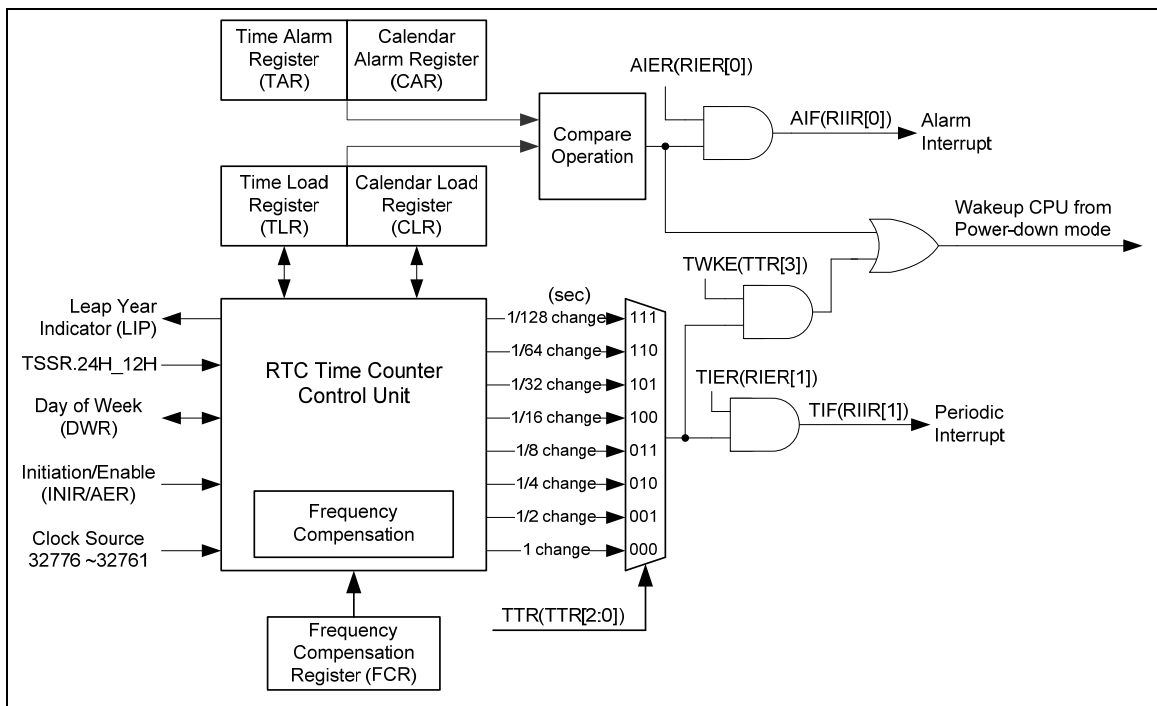

Figure 5-49 RTC Block Diagram

## 5.8.4 Function Description

### 5.8.4.1 Access to RTC register

Due to clock difference between RTC clock and system clock, when user write new data to any one of the registers, the register will not be updated until 2 RTC clocks later (60us).

In addition, user must be aware that RTC controller does not check whether loaded data is out of bounds or not. RTC does not check rationality between DWR and CLR either.

### 5.8.4.2 RTC Initiation

When RTC block is power on, RTC is at reset state. User has to write a number (0xa5eb1357) to INIR to make RTC leaving reset state. Once the INIR is written as 0xa5eb1357, the RTC will be in un-reset state permanently.

### 5.8.4.3 RTC Read/Write Enable

Register AER bit 15~0 is served as RTC read/write password to protect RTC registers. AER bit 15~0 has to be set as 0xA965 to enable access restriction. Once it is set, it will take effect at least 1024 RTC clocks (about 30ms). Programmer can read RTC enabled status flag in AER.ENF to check whether if RTC controller starts operating or not.

### 5.8.4.4 Frequency Compensation

The RTC clock source may not precise to exactly 32768 Hz and the RTC register (FCR) allows software to make digital compensation to the RTC source clock if the frequency of RTC source clock is in the range from 32761 Hz to 32776 Hz. Following are the compensation examples for higher or lower frequency clock input.

Example 1:

Frequency counter measurement : 32773.65 Hz ( > 32768 Hz)

Integer part: 32773 => 0x8005

FCR.Integer = 0x05 – 0x01 + 0x08 = 0x0c

Fraction part: 0.65 x 60 = 39 => 0x27

FCR.Fraction = 0x27

Example 2

Frequency counter measurement : 32765.27 Hz ( ≤ 32768 Hz)

Integer part: 32765 => 0x7FFD

FCR.Integer = 0x0D – 0x01 – 0x08 = 0x04

Fraction part: 0.27 x 60 = 16.2=> 0x10

FCR.Fraction = 0x10

### 5.8.4.5 Time and Calendar counter

TLR and CLR are used to load the time and calendar. TAR and CAR are used for alarm. They are all represented by BCD.

### 5.8.4.6 12/24 hour Time Scale Selection

The 12/24 hour time scale selection depends on TSSR bit 0.



### 5.8.4.7 Day of the week counter

The RTC controller provides day of week in Day of the Week Register (DWR). The value is defined from 0 to 6 to represent Sunday to Saturday respectively.

### 5.8.4.8 Periodic Time Tick Interrupt

The periodic interrupt has 8 period option 1/128, 1/64, 1/32, 1/16, 1/8, 1/4, 1/2 and 1 second which are selected by TTR.TTR[2:0]. When periodic time tick interrupt is enabled by setting RIER.TIER to 1, the Periodic Time Tick Interrupt is requested periodically in the period selected by TTR register.

### 5.8.4.9 Alarm interrupt

When RTC counter in TLR and CLR is equal to alarm setting time TAR and CAR the alarm interrupt flag (RIIR.AIF) is set and the alarm interrupt is requested if the alarm interrupt is enabled (RIER.AIER=1).

### 5.8.4.10 Application note:

1. TAR, CAR, TLR and CLR registers are all BCD counter.
2. Programmer has to make sure that the loaded values are reasonable. For example, Load CLR as 201a (year), 13 (month), 00 (day), or CLR does not match with DWR, etc.
3. Reset state :

Register	Reset State
AER	0
CLR	05/1/1 (year/month/day)
TLR	00:00:00 (hour : minute : second)
CAR	00/00/00 (year/month/day)
TAR	00:00:00 (hour : minute : second)
TSSR	1 (24 hr mode)
DWR	6 (Saturday)
RIER	0
RIIR	0
LIR	0
TTR	0

4. In CLR and CAR, only 2 BCD digits are used to express "year". We assume 2 BCD digits of xY denote 20xY, but not 19xY or 21xY.



## 5.8.5 Register Map

R: read only, W: write only, R/W: both read and write

Register	Offset	R/W	Description	Reset Value
<b>RTC_BA = 0x4000_8000</b>				
<b>INIR</b>	RTC_BA+0x00	R/W	RTC Initiation Register	0x0000_0000
<b>AER</b>	RTC_BA+0x04	R/W	RTC Access Enable Register	0x0000_0000
<b>FCR</b>	RTC_BA+0x08	R/W	RTC Frequency Compensation Register	0x0000_0700
<b>TLR</b>	RTC_BA+0x0C	R/W	Time Loading Register	0x0000_0000
<b>CLR</b>	RTC_BA+0x10	R/W	Calendar Loading Register	0x0005_0101
<b>TSSR</b>	RTC_BA+0x14	R/W	Time Scale Selection Register	0x0000_0001
<b>DWR</b>	RTC_BA+0x18	R/W	Day of the Week Register	0x0000_0006
<b>TAR</b>	RTC_BA+0x1C	R/W	Time Alarm Register	0x0000_0000
<b>CAR</b>	RTC_BA+0x20	R/W	Calendar Alarm Register	0x0000_0000
<b>LIR</b>	RTC_BA+0x24	R	Leap Year Indicator Register	0x0000_0000
<b>RIER</b>	RTC_BA+0x28	R/W	RTC Interrupt Enable Register	0x0000_0000
<b>RIIR</b>	RTC_BA+0x2C	R/W	RTC Interrupt Indicator Register	0x0000_0000
<b>TTR</b>	RTC_BA+0x30	R/W	RTC Time Tick Register	0x0000_0000





5.8.6 Register Description

**RTC Initiation Register (INIR)**

Register	Offset	R/W	Description	Reset Value
INIR	RTC_BA+0x00	R/W	RTC Initiation Register	0x0000_0000

31	30	29	28	27	26	25	24
INIR							
23	22	21	20	19	18	17	16
INIR							
15	14	13	12	11	10	9	8
INIR							
7	6	5	4	3	2	1	0
INIR							INIR[0]/Active

Bits	Descriptions	
[31:1]	INIR[31:1]	<p><b>RTC Initiation</b></p> <p>When RTC block is power on, RTC is at reset state. User has to write a number (0xa5eb1357) to INIR to make RTC leaving reset state. Once the INIR is written as 0xa5eb1357, the RTC will be in un-reset state permanently.</p> <p>The INIR is a write-only field and read value will be always "0".</p>
[0]	INIR[0]/Active	<p><b>RTC Active Status (Read only)</b></p> <p>0 = RTC is at reset state</p> <p>1 = RTC is at normal active state.</p>



## RTC Access Enable Register (AER)

Register	Offset	R/W	Description	Reset Value
AER	RTC_BA+0x04	R/W	RTC Access Enable Register	0x0000_0000

31	30	29	28	27	26	25	24
Reserved							
23	22	21	20	19	18	17	16
Reserved							ENF
15	14	13	12	11	10	9	8
AER							
7	6	5	4	3	2	1	0
AER							

Bits	Descriptions																																																																							
[31:17]	Reserved	Reserved																																																																						
[16]	ENF	<p><b>RTC Register Access Enable Flag (Read only)</b></p> <p>1 = RTC register read/write enable 0 = RTC register read/write disable</p> <p>This bit will be set after AER[15:0] register is load a 0xA965, and be clear automatically 1024 RTC clock.</p> <table border="1" style="width: 100%; border-collapse: collapse;"> <thead> <tr> <th style="width: 30%;">Register</th> <th style="width: 30%;">AER</th> <th style="width: 10%;">ENF</th> <th style="width: 10%;">1</th> <th style="width: 10%;">0</th> </tr> </thead> <tbody> <tr> <td>INIR</td> <td>R/W</td> <td></td> <td>R/W</td> <td>R/W</td> </tr> <tr> <td>AER</td> <td>R/W</td> <td></td> <td>R/W</td> <td>R/W</td> </tr> <tr> <td>FCR</td> <td>R/W</td> <td></td> <td>R/W</td> <td>-</td> </tr> <tr> <td>TLR</td> <td>R/W</td> <td></td> <td>R/W</td> <td>R</td> </tr> <tr> <td>CLR</td> <td>R/W</td> <td></td> <td>R/W</td> <td>R</td> </tr> <tr> <td>TSSR</td> <td>R/W</td> <td></td> <td>R/W</td> <td>R/W</td> </tr> <tr> <td>DWR</td> <td>R/W</td> <td></td> <td>R/W</td> <td>R</td> </tr> <tr> <td>TAR</td> <td>R/W</td> <td></td> <td>R/W</td> <td>-</td> </tr> <tr> <td>CAR</td> <td>R/W</td> <td></td> <td>R/W</td> <td>-</td> </tr> <tr> <td>LIR</td> <td>R</td> <td></td> <td>R</td> <td>R</td> </tr> <tr> <td>RIER</td> <td>R/W</td> <td></td> <td>R/W</td> <td>R/W</td> </tr> <tr> <td>RIIR</td> <td>R/W</td> <td></td> <td>R/W</td> <td>R/W</td> </tr> <tr> <td>TTR</td> <td>R/W</td> <td></td> <td>R/W</td> <td>-</td> </tr> </tbody> </table>	Register	AER	ENF	1	0	INIR	R/W		R/W	R/W	AER	R/W		R/W	R/W	FCR	R/W		R/W	-	TLR	R/W		R/W	R	CLR	R/W		R/W	R	TSSR	R/W		R/W	R/W	DWR	R/W		R/W	R	TAR	R/W		R/W	-	CAR	R/W		R/W	-	LIR	R		R	R	RIER	R/W		R/W	R/W	RIIR	R/W		R/W	R/W	TTR	R/W		R/W	-
Register	AER	ENF	1	0																																																																				
INIR	R/W		R/W	R/W																																																																				
AER	R/W		R/W	R/W																																																																				
FCR	R/W		R/W	-																																																																				
TLR	R/W		R/W	R																																																																				
CLR	R/W		R/W	R																																																																				
TSSR	R/W		R/W	R/W																																																																				
DWR	R/W		R/W	R																																																																				
TAR	R/W		R/W	-																																																																				
CAR	R/W		R/W	-																																																																				
LIR	R		R	R																																																																				
RIER	R/W		R/W	R/W																																																																				
RIIR	R/W		R/W	R/W																																																																				
TTR	R/W		R/W	-																																																																				
[15:0]	AER	<p><b>RTC Register Access Enable Password (Write only)</b></p> <p>Write 0xA965 to this register will enable RTC access and keep 1024 RTC clock</p>																																																																						



## RTC Frequency Compensation Register (FCR)

Register	Offset	R/W	Description	Reset Value
FCR	RTC_BA+0x08	R/W	Frequency Compensation Register	0x0000_0700

31	30	29	28	27	26	25	24
Reserved							
23	22	21	20	19	18	17	16
Reserved							
15	14	13	12	11	10	9	8
Reserved				INTEGER			
7	6	5	4	3	2	1	0
Reserved		FRACTION					

Bits	Descriptions																																					
[31:12]	Reserved	Reserved																																				
[11:8]	INTEGER	<b>Integer Part</b> <table border="1" style="width: 100%; text-align: center;"> <thead> <tr> <th>Integer part of detected value</th> <th>FCR[11:8]</th> <th>Integer part of detected value</th> <th>FCR[11:8]</th> </tr> </thead> <tbody> <tr><td>32776</td><td>1111</td><td>32768</td><td>0111</td></tr> <tr><td>32775</td><td>1110</td><td>32767</td><td>0110</td></tr> <tr><td>32774</td><td>1101</td><td>32766</td><td>0101</td></tr> <tr><td>32773</td><td>1100</td><td>32765</td><td>0100</td></tr> <tr><td>32772</td><td>1011</td><td>32764</td><td>0011</td></tr> <tr><td>32771</td><td>1010</td><td>32763</td><td>0010</td></tr> <tr><td>32770</td><td>1001</td><td>32762</td><td>0001</td></tr> <tr><td>32769</td><td>1000</td><td>32761</td><td>0000</td></tr> </tbody> </table>	Integer part of detected value	FCR[11:8]	Integer part of detected value	FCR[11:8]	32776	1111	32768	0111	32775	1110	32767	0110	32774	1101	32766	0101	32773	1100	32765	0100	32772	1011	32764	0011	32771	1010	32763	0010	32770	1001	32762	0001	32769	1000	32761	0000
Integer part of detected value		FCR[11:8]	Integer part of detected value	FCR[11:8]																																		
32776		1111	32768	0111																																		
32775		1110	32767	0110																																		
32774		1101	32766	0101																																		
32773		1100	32765	0100																																		
32772		1011	32764	0011																																		
32771		1010	32763	0010																																		
32770		1001	32762	0001																																		
32769	1000	32761	0000																																			
[5:0]	FRACTION	<b>Fraction Part</b> Formula = (fraction part of detected value) x 60 Note: Digit in FCR must be expressed as hexadecimal number. Refer to 5.8.4.4 for the examples.																																				

Note: This register can be read back after the RTC register access enable bit ENF (AER[16]) is active.



## RTC Time Loading Register (TLR)

Register	Offset	R/W	Description	Reset Value
TLR	RTC_BA+0x0C	R/W	Time Loading Register	0x0000_0000

31	30	29	28	27	26	25	24
Reserved							
23	22	21	20	19	18	17	16
Reserved		10HR		1HR			
15	14	13	12	11	10	9	8
Reserved	10MIN			1MIN			
7	6	5	4	3	2	1	0
Reserved	10SEC			1SEC			

Bits	Descriptions	
[31:22]	Reserved	Reserved
[21:20]	10HR	10-Hour Time Digit (0~2)
[19:16]	1HR	1-Hour Time Digit (0~9)
[15]	Reserved	Reserved
[14:12]	10MIN	10-Min Time Digit (0~5)
[11:8]	1MIN	1-Min Time Digit (0~9)
[7]	Reserved	Reserved
[6:4]	10SEC	10-Sec Time Digit (0~5)
[3:0]	1SEC	1-Sec Time Digit (0~9)

Note:

1. TLR is a BCD digit counter and RTC will not check loaded data.
2. The reasonable value range is listed in the parenthesis.



## RTC Calendar Loading Register (CLR)

Register	Offset	R/W	Description	Reset Value
CLR	RTC_BA+0x10	R/W	Calendar Loading Register	0x0005_0101

31	30	29	28	27	26	25	24
Reserved							
23	22	21	20	19	18	17	16
10YEAR				1YEAR			
15	14	13	12	11	10	9	8
Reserved			10MON	1MON			
7	6	5	4	3	2	1	0
Reserved		10DAY		1DAY			

Bits	Descriptions	
[31:24]	Reserved	Reserved
[23:20]	10YEAR	10-Year Calendar Digit (0~9)
[19:16]	1YEAR	1-Year Calendar Digit (0~9)
[15:13]	Reserved	Reserved
[12]	10MON	10-Month Calendar Digit (0~1)
[11:8]	1MON	1-Month Calendar Digit (0~9)
[7:6]	Reserved	Reserved
[5:4]	10DAY	10-Day Calendar Digit (0~3)
[3:0]	1DAY	1-Day Calendar Digit (0~9)

Note:

1. CLR is a BCD digit counter and RTC will not check loaded data.
2. The reasonable value range is listed in the parenthesis.



## RTC Time Scale Selection Register (TSSR)

Register	Offset	R/W	Description	Reset Value
TSSR	RTC_BA+0x14	R/W	Time Scale Selection Register	0x0000_0001

31	30	29	28	27	26	25	24
Reserved							
23	22	21	20	19	18	17	16
Reserved							
15	14	13	12	11	10	9	8
Reserved							
7	6	5	4	3	2	1	0
Reserved							24H_12H

Bits	Descriptions				
[31:1]	Reserved	Reserved			
[0]	24H_12H	<b>24-Hour / 12-Hour Time Scale Selection</b> It indicate that TLR and TAR are in 24-hour time scale or 12-hour time scale 1 = select 24-hour time scale 0 = select 12-hour time scale with AM and PM indication			
		24-hour time scale	12-hour time scale	24-hour time scale	12-hour time scale (PM time + 20)
		00	12(AM12)	12	32(PM12)
		01	01 (AM01)	13	21 (PM01)
		02	02(AM02)	14	22(PM02)
		03	03(AM03)	15	23(PM03)
		04	04 (AM04)	16	24 (PM04)
		05	05(AM05)	17	25(PM05)
		06	06(AM06)	18	26(PM06)
		07	07(AM07)	19	27(PM07)
		08	08(AM08)	20	28(PM08)
		09	09(AM09)	21	29(PM09)
		10	10 (AM10)	22	30 (PM10)
11	11 (AM11)	23	31 (PM11)		



## RTC Day of the Week Register (DWR)

Register	Offset	R/W	Description	Reset Value
DWR	RTC_BA+0x18	R/W	Day of the Week Register	0x0000_0006

31	30	29	28	27	26	25	24
Reserved							
23	22	21	20	19	18	17	16
Reserved							
15	14	13	12	11	10	9	8
Reserved							
7	6	5	4	3	2	1	0
Reserved					DWR		

Bits	Descriptions																	
[31:3]	Reserved	Reserved																
[2:0]	DWR	<b>Day of the Week Register</b> <table border="1" style="margin-left: 20px;"> <thead> <tr> <th>Value</th> <th>Day of the Week</th> </tr> </thead> <tbody> <tr> <td>0</td> <td>Sunday</td> </tr> <tr> <td>1</td> <td>Monday</td> </tr> <tr> <td>2</td> <td>Tuesday</td> </tr> <tr> <td>3</td> <td>Wednesday</td> </tr> <tr> <td>4</td> <td>Thursday</td> </tr> <tr> <td>5</td> <td>Friday</td> </tr> <tr> <td>6</td> <td>Saturday</td> </tr> </tbody> </table>	Value	Day of the Week	0	Sunday	1	Monday	2	Tuesday	3	Wednesday	4	Thursday	5	Friday	6	Saturday
		Value	Day of the Week															
		0	Sunday															
		1	Monday															
		2	Tuesday															
		3	Wednesday															
		4	Thursday															
		5	Friday															
6	Saturday																	



## RTC Time Alarm Register (TAR)

Register	Offset	R/W	Description	Reset Value
TAR	RTC_BA+0x1C	R/W	Time Alarm Register	0x0000_0000

31	30	29	28	27	26	25	24
Reserved							
23	22	21	20	19	18	17	16
Reserved		10HR		1HR			
15	14	13	12	11	10	9	8
Reserved	10MIN			1MIN			
7	6	5	4	3	2	1	0
Reserved	10SEC			1SEC			

Bits	Descriptions	
[31:22]	Reserved	Reserved
[21:20]	10HR	10-Hour Time Digit of Alarm Setting (0~2)
[19:16]	1HR	1-Hour Time Digit of Alarm Setting (0~9)
[15]	Reserved	Reserved
[14:12]	10MIN	10-Min Time Digit of Alarm Setting (0~5)
[11:8]	1MIN	1-Min Time Digit of Alarm Setting (0~9)
[7]	Reserved	Reserved
[6:4]	10SEC	10-Sec Time Digit of Alarm Setting (0~5)
[3:0]	1SEC	1-Sec Time Digit of Alarm Setting (0~9)

Note:

1. TAR is a BCD digit counter and RTC will not check loaded data.
2. The reasonable value range is listed in the parenthesis.
3. This register can be read back after the RTC register access enable bit ENF (AER[16]) is active.





## RTC Calendar Alarm Register (CAR)

Register	Offset	R/W	Description	Reset Value
CAR	RTC_BA+0x20	R/W	Calendar Alarm Register	0x0000_0000

31	30	29	28	27	26	25	24
Reserved							
23	22	21	20	19	18	17	16
10YEAR				1YEAR			
15	14	13	12	11	10	9	8
Reserved			10MON	1MON			
7	6	5	4	3	2	1	0
Reserved		10DAY		1DAY			

Bits	Descriptions	
[31:24]	Reserved	Reserved
[23:20]	10YEAR	10-Year Calendar Digit of Alarm Setting (0~9)
[19:16]	1YEAR	1-Year Calendar Digit of Alarm Setting (0~9)
[15:13]	Reserved	Reserved
[12]	10MON	10-Month Calendar Digit of Alarm Setting (0~1)
[11:8]	1MON	1-Month Calendar Digit of Alarm Setting (0~9)
[7:6]	Reserved	Reserved
[5:4]	10DAY	10-Day Calendar Digit of Alarm Setting (0~3)
[3:0]	1DAY	1-Day Calendar Digit of Alarm Setting (0~9)

Note:

1. CAR is a BCD digit counter and RTC will not check loaded data.
2. The reasonable value range is listed in the parenthesis.
3. This register can be read back after the RTC register access enable bit ENF (AER[16]) is active.



## RTC Leap Year Indication Register (LIR)

Register	Offset	R/W	Description	Reset Value
LIR	RTC_BA+0x24	R	RTC Leap Year Indication Register	0x0000_0000

31	30	29	28	27	26	25	24
Reserved							
23	22	21	20	19	18	17	16
Reserved							
15	14	13	12	11	10	9	8
Reserved							
7	6	5	4	3	2	1	0
Reserved							LIR

Bits	Descriptions	
[31:1]	Reserved	Reserved
[0]	LIR	<b>Leap Year Indication Register (Real only).</b> 1 = It indicate that this year is leap year 0 = It indicate that this year is not a leap year



## RTC Interrupt Enable Register (RIER)

Register	Offset	R/W	Description	Reset Value
RIER	RTC_BA+0x28	R/W	RTC Interrupt Enable Register	0x0000_0000

31	30	29	28	27	26	25	24
Reserved							
23	22	21	20	19	18	17	16
Reserved							
15	14	13	12	11	10	9	8
Reserved							
7	6	5	4	3	2	1	0
Reserved						TIER	AIER

Bits	Descriptions	
[31:2]	Reserved	Reserved
[1]	TIER	<b>Time Tick Interrupt Enable</b> 1 = RTC Time Tick Interrupt is enabled 0 = RTC Time Tick Interrupt is disabled
[0]	AIER	<b>Alarm Interrupt Enable</b> 1 = RTC Alarm Interrupt is enabled 0 = RTC Alarm Interrupt is disabled



## RTC Interrupt Indication Register (RIIR)

Register	Offset	R/W	Description	Reset Value
RIIR	RTC_BA+0x2C	R/W	RTC Interrupt Indication Register	0x0000_0000

31	30	29	28	27	26	25	24
Reserved							
23	22	21	20	19	18	17	16
Reserved							
15	14	13	12	11	10	9	8
Reserved							
7	6	5	4	3	2	1	0
Reserved						TIF	AIF

Bits	Descriptions	
[31:2]	Reserved	Reserved
[1]	TIF	<p><b>RTC Time Tick Interrupt Flag</b></p> <p>When RTC Time Tick Interrupt is enabled (RIER.TIER=1), RTC controller will set TIF to high periodically in the period selected by TTR[2:0]. This bit is software clear by writing 1 to it.</p> <p>1= Indicates RTC Time Tick Interrupt is requested if RIER.TIER=1 0= Indicates RCT Time Tick Interrupt condition never occurred.</p>
[0]	AIF	<p><b>RTC Alarm Interrupt Flag</b></p> <p>When RTC Alarm Interrupt is enabled (RIER.AIER=1), RTC controller will set AIF to high once the RTC real time counters TLR and CLR reach the alarm setting time registers TAR and CAR. This bit is software clear by writing 1 to it.</p> <p>1= Indicates RTC Alarm Interrupt is requested if RIER.AIER=1 0= Indicates RCT Alarm Interrupt condition never occurred.</p>



## RTC Time Tick Register (TTR)

Register	Offset	R/W	Description	Reset Value
TTR	RTC_BA+0x30	R/W	RTC Time Tick Register	0x0000_0000

31	30	29	28	27	26	25	24
Reserved							
23	22	21	20	19	18	17	16
Reserved							
15	14	13	12	11	10	9	8
Reserved							
7	6	5	4	3	2	1	0
Reserved				TWKE	TTR[2:0]		

Bits	Descriptions																			
[31:4]	Reserved	Reserved																		
[3]	TWKE	<p><b>RTC Timer Wake-up Function Enable</b></p> <p>If TWKE is set before chip is in power down mode, chip will be wakened up by RTC controller when a RTC Time Tick occurs.</p> <p>1 = Enable RTC Timer wake-up function that chip can be waken up from power down mode by Time Tick.</p> <p>0 = Disable RTC Timer wake-up by Timer Tick occur function.</p> <p>Note: Tick timer setting follows TTR[2:0] description.</p> <p>Note: When Alarm Match occurs, chip will be waken-up from power down mode no matter TWKE is 1 or 0.</p>																		
[2:0]	TTR	<p><b>Time Tick Register</b></p> <p>The RTC time tick period for Periodic Time Tick Interrupt request.</p> <table border="1" style="margin-left: 20px;"> <thead> <tr> <th>TTR[2:0]</th> <th>Time tick (second)</th> </tr> </thead> <tbody> <tr><td>0</td><td>1</td></tr> <tr><td>1</td><td>1/2</td></tr> <tr><td>2</td><td>1/4</td></tr> <tr><td>3</td><td>1/8</td></tr> <tr><td>4</td><td>1/16</td></tr> <tr><td>5</td><td>1/32</td></tr> <tr><td>6</td><td>1/64</td></tr> <tr><td>7</td><td>1/128</td></tr> </tbody> </table> <p>Note: This register can be read back after the RTC register access enable bit ENF (AER[16]) is active.</p>	TTR[2:0]	Time tick (second)	0	1	1	1/2	2	1/4	3	1/8	4	1/16	5	1/32	6	1/64	7	1/128
TTR[2:0]	Time tick (second)																			
0	1																			
1	1/2																			
2	1/4																			
3	1/8																			
4	1/16																			
5	1/32																			
6	1/64																			
7	1/128																			

## 5.9 Serial Peripheral Interface (SPI)

### 5.9.1 Overview

The Serial Peripheral Interface (SPI) is a synchronous serial data communication protocol which operates in full duplex mode. Devices communicate in master/slave mode with 4-wire bi-direction interface. The NuMicro™ NUC100/NUC120 Medium Density contains up to four sets of SPI controller performing a serial-to-parallel conversion on data received from a peripheral device, and a parallel-to-serial conversion on data transmitted to a peripheral device. Each set of SPI controller can be set as a master that can drive up to 2 external peripheral slave devices; it also can be configured as a slave device controlled by an off-chip master device. NuMicro™ NUC100/NUC120 Low Density contains two sets of SPI controller only.

This controller supports a variable serial clock for special application and it also supports 2-bit transfer mode to connect 2 off-chip slave devices at the same time. The SPI controller also supports PDMA function to access the data buffer.

### 5.9.2 Features

- Up to four sets of SPI controller for NuMicro™ NUC100/NUC120 Medium Density
- Up to two sets of SPI controller for NuMicro™ NUC100/NUC120 Low Density
- Support master or slave mode operation
- Support 1-bit or 2-bit transfer mode
- Configurable bit length up to 32-bit of a transfer word and configurable word numbers up to 2 of a transaction, so the maximum bit length is 64-bit for each data transfer
- Provide burst mode operation, transmit/receive can be transferred up to two times word transaction in one transfer
- Support MSB or LSB first transfer
- 2 device/slave select lines in master mode, but 1 device/slave select line in slave mode
- Support byte reorder function
- Support byte or word suspend mode
- Variable output serial clock frequency in master mode
- Support two programmable serial clock frequencies in master mode
- Support two channel PDMA request, one for transmitter and another for receiver

5.9.3 Block Diagram

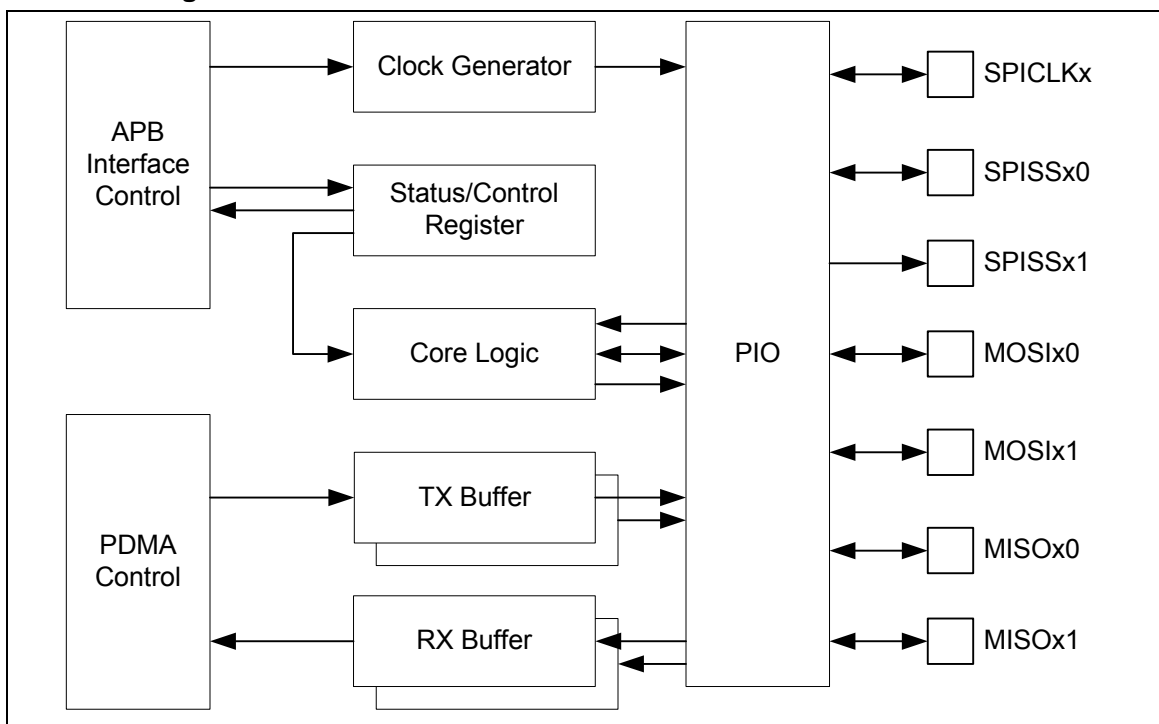

Figure 5-50 SPI Block Diagram

5.9.4 Function Description

Master/Slave Mode

This SPI controller can be set as master or slave mode by setting the SLAVE bit (SPI\_CNTRL[18]) to communicate with the off-chip SPI slave or master device. The application block diagrams in master and slave mode are shown as below. This SPI controller does not support multi-slave in SPI bus if the controller is set as slave mode. In slave mode, the SPI clock pin must be kept at idle state when the slave select pin is at inactive state.

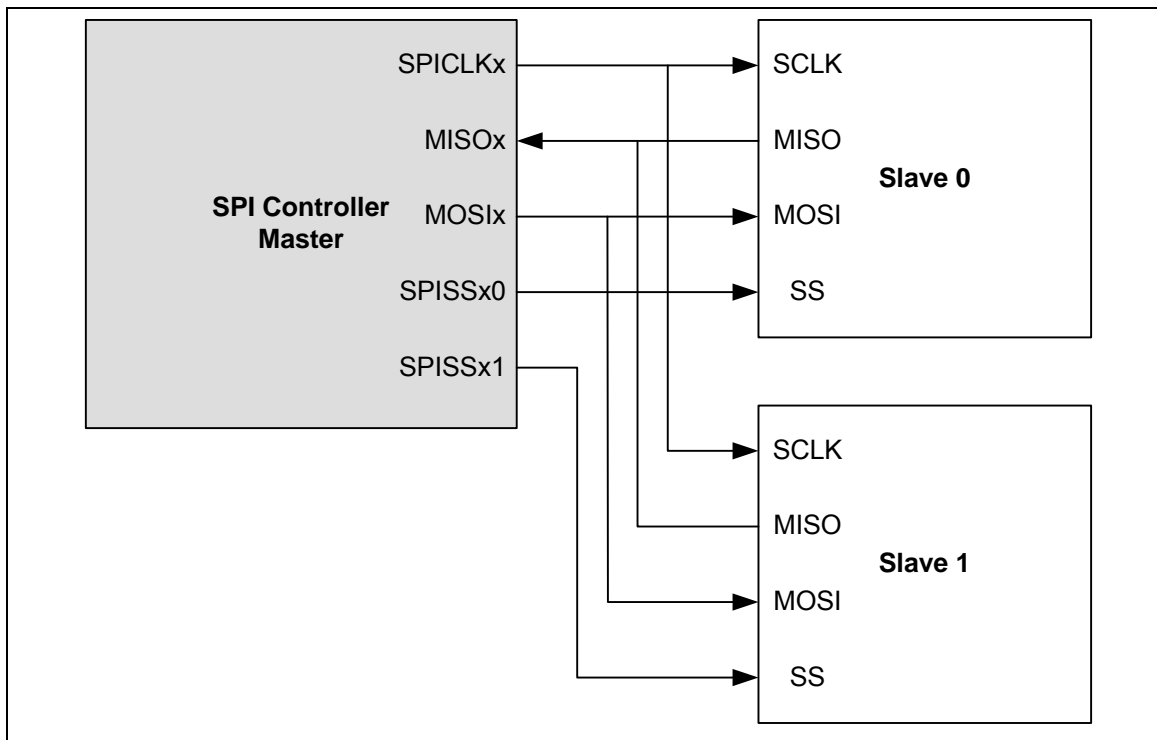

Figure 5-51 SPI Master Mode Application Block Diagram

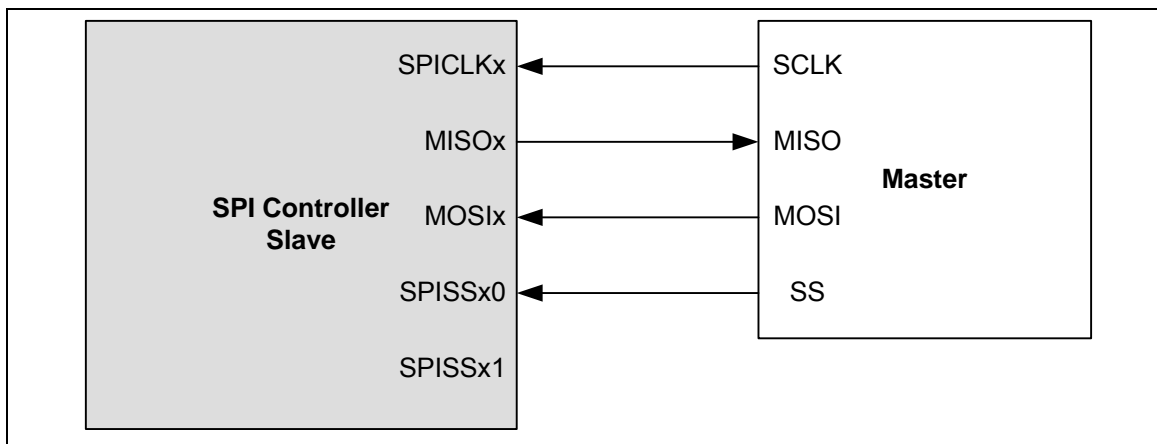



Figure 5-52 SPI Slave Mode Application Block Diagram

### Slave Select

In master mode, this SPI controller can drive up to two off-chip slave devices through the slave select output pins SPISSx0 and SPISSx1. In slave mode, the off-chip master device drives the slave select signal from the SPISSx0 input port to this SPI controller. In master/slave mode, the active state of slave select signal can be programmed to low active or high active in SS\_LVL bit (SPI\_SSR[2]), and the SS\_LTRIG bit (SPI\_SSR[4]) defines the slave select signal SPISSx0/1 is level trigger or edge trigger. The selection of trigger condition depends on what type of peripheral slave/master device is connected.

In slave mode, if the SS\_LTRIG bit is configured as level trigger, the LTRIG\_FLAG bit (SPI\_SSR[5]) is used to indicate if both the received number and received bits met the requirement which defines in TX\_NUM and TX\_BIT\_LEN among one transaction done (the transaction done means the slave select has deactivated or the SPI controller has finished one data transfer.)

### Level-trigger / Edge-trigger

In slave mode, the slave select signal can be configured as level-trigger or edge-trigger. In edge-trigger, the data transfer starts from an active edge and ends on an inactive edge. If master does not send an inactive edge to slave, the transfer procedure will not be completed and the interrupt flag of slave will not be set. In level-trigger, the following two conditions will terminate the transfer procedure and the interrupt flag of slave will be set. The first condition, if master set the slave select pin to inactive level, it will force slave device to terminate the current transfer no matter how many bits have been transferred and the interrupt flag will be set. User can read the status of LTRIG\_FLAG bit to check if the data has been completely transferred. The second condition is that if the number of transferred bits matches the settings of TX\_NUM and TX\_BIT\_LEN, the interrupt flag of slave will be set.

### Automatic Slave Select

In master mode, if the bit AUTOSS (SPI\_SSR[3]) is set, the slave select signals will be generated automatically and output to SPISSx0 and SPISSx1 pins according to SSR[0] (SPI\_SSR[0]) and SSR[1] (SPI\_SSR[1]) whether be enabled or not. It means that the slave select signals, which are selected in SSR[1:0], will be asserted by the SPI controller when transmit/receive is started by setting the GO\_BUSY bit (SPI\_CNTRL[0]) and will be de-asserted after the data transfer is finished. If the AUTOSS bit is cleared, the slave select output signals will be asserted/de-asserted by manual setting/clearing the related bits of SPI\_SSR[1:0]. The active state of the slave select output signals is specified in SS\_LVL bit (SPI\_SSR[2]).

### Serial Clock

In master mode, set the DIVIDER1 bits (SPI\_DIVIDER[15:0]) to program the output frequency of serial clock to the SPICLK output port. It also supports a variable serial clock if the VARCLK\_EN bit (SPI\_CTL[23]) is enabled. In this case, the output frequency of serial clock can be programmed as one of the two different frequencies which depend on the value of DIVIDER1 (SPI\_DIVIDER[15:0]) and DIVIDER2 (SPI\_DIVIDER[31:16]). The serial clock rate of each cycle is depended on the setting of the SPI\_VARCLK register.

In slave mode, the off-chip master device drives the serial clock through the SPICLK input port to this SPI controller.

## Variable Serial Clock Frequency

In master mode, the output of serial clock can be programmed as variable frequency pattern if the Variable Clock Enable bit VARCLK\_EN (SPI\_CNTRL[23]) is enabled. The frequency pattern format is defined in VARCLK (SPI\_VARCLK[31:0]) register. If the bit content of VARCLK is '0' the output frequency is according with the DIVIDER (SPI\_DIVIDER[15:0]) and if the bit content of VARCLK is '1', the output frequency is according to the DIVIDER2 (SPI\_DIVIDER[31:16]). Figure 5-53 is the timing relationship among the serial clock (SPICLK), the VARCLK, the DIVIDER and the DIVIDER2 registers. A two-bit combination in the VARCLK defines one clock cycle. The bit field VARCLK[31:30] defines the first clock cycle of SPICLK. The bit field VARCLK[29:28] defines the second clock cycle of SPICLK and so on. The clock source selections are defined in VARCLK and it must be set 1 cycle before the next clock option. For example, if there are 5 CLK1 cycle in SPICLK, the VARCLK shall set 9 '0' in the MSB of VARCLK. The 10th shall be set as '1' in order to switch the next clock source is CLK2. Note that when enable the VARCLK\_EN bit, the setting of TX\_BIT\_LEN must be programmed as 0x10 (16-bit mode only).

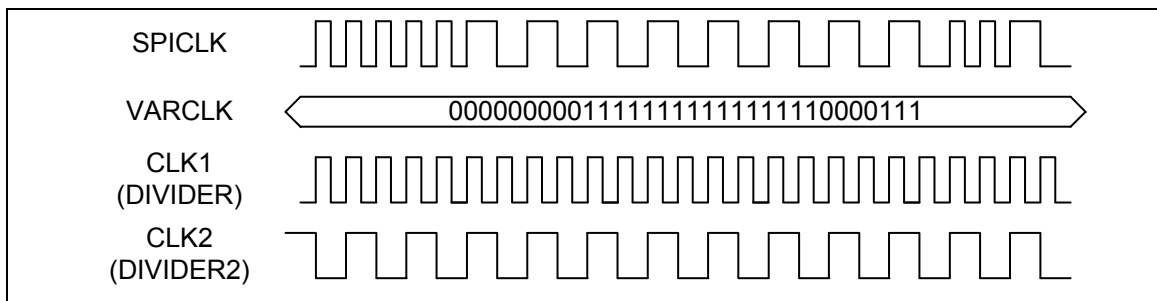

Figure 5-53 Variable Serial Clock Frequency

## Clock Polarity

The CLKP bit (SPI\_CTL[11]) defines the serial clock idle state. If CLKP = 1, the output SPICLK is idle at high state, otherwise it is at low state if CLKP = 0.

## Transmit/Receive Bit Length

The bit length of a transaction word is defined in TX\_BIT\_LEN bit field (SPI\_CNTRL[7:3]). It can be configured up to 32-bit length in a transaction word for transmitting and receiving.

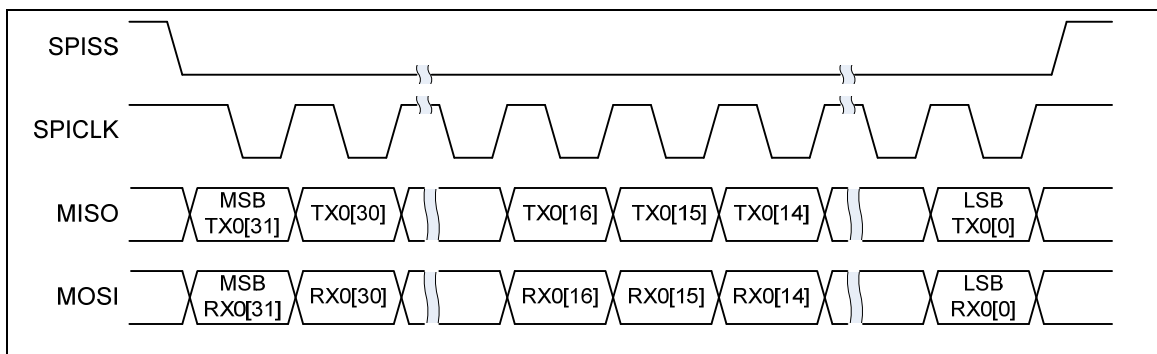

Figure 5-54 32-Bit in one Transaction

## Burst Mode

SPI controller can switch to burst mode by setting TX\_NUM bit field (SPI\_CNTRL[9:8]) to 0x01. In burst mode, SPI can transmit/receive two transactions in one transfer. The SPI burst mode waveform is showed below:

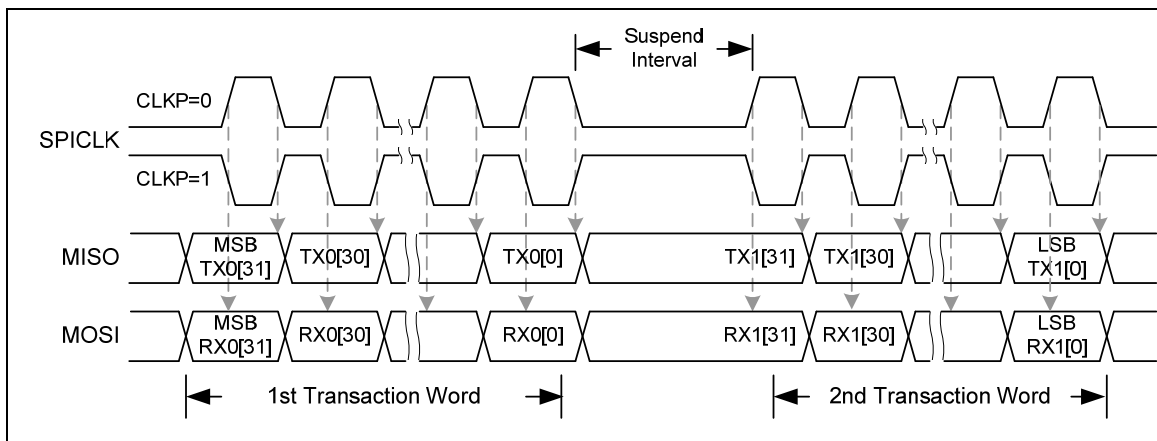

Figure 5-55 Two Transactions in One Transfer (Burst Mode)

## LSB First

The LSB bit (SPI\_CNTRL[10]) defines the data transmission either from LSB or MSB firstly to start to transmit/receive data.

## Transmit Edge

The TX\_NEG bit (SPI\_CNTRL[2]) defines the data transmitted out either at negative edge or at positive edge of serial clock SPICLK.

## Receive Edge

The Rx\_NEG bit (SPI\_CNTRL[1]) defines the data received in either at negative edge or at positive edge of serial clock SPICLK.

Note: the settings of TX\_NEG and RX\_NEG are mutual exclusive. In other words, don't transmit and receive data at the same clock edge.

## Word Suspend

These four bits field of SP\_CYCLE (SPI\_CNTRL[15:12]) provide a configurable suspend interval 2 ~ 17 serial clock periods between two successive transaction words in master mode. The suspend interval is from the last falling clock edge of the preceding transaction word to the first rising clock edge of the following transaction word if CLKP = 0. If CLKP = 1, the interval is from the rising clock edge of the preceding transaction word to the falling clock edge of the following transaction word. The default value of SP\_CYCLE is 0x0 (2 serial clock cycles), but set these bits field has no any effects on data transaction process if TX\_NUM = 0x00.

## Byte Reorder

When the transfer is set as MSB first (LSB = 0) and the REORDER is enabled, the data stored in the TX buffer and RX buffer will be rearranged in the order as [BYTE0, BYTE1, BYTE2, BYTE3] in TX\_BIT\_LEN = 32-bit mode, and the sequence of transmitted/received data will be BYTE0, BYTE1, BYTE2, and then BYTE3. If the TX\_BIT\_LEN is set as 24-bit mode, the data in TX buffer and RX buffer will be rearranged as [unknown byte, BYTE0, BYTE1, BYTE2]. The SPI controller will transmit/receive data with the sequence of BYTE0, BYTE1 and then BYTE2. Each byte will be transmitted/received with MSB first. The rule of 16-bit mode is the same as above. Byte reorder function is only available when TX\_BIT\_LEN is configured as 16, 24, and 32 bits.

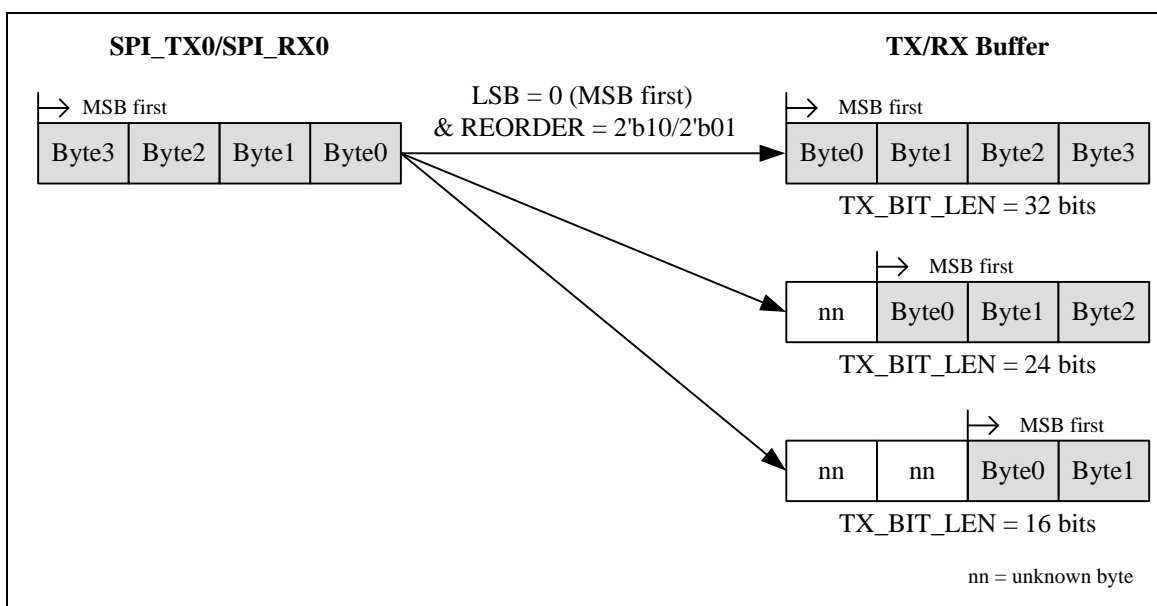

Figure 5-56 Byte Reorder

## Byte Suspend

In master mode, if SPI\_CNTRL[19] is set to 1, the hardware will insert a suspend interval 2 ~ 17 serial clock periods between two successive bytes in a transaction word. Both settings of byte suspend and word suspend are configured in SP\_CYCLE. Note that when enable the byte suspend function, the setting of TX\_BIT\_LEN must be programmed as 0x00 only (32-bit per transaction word).

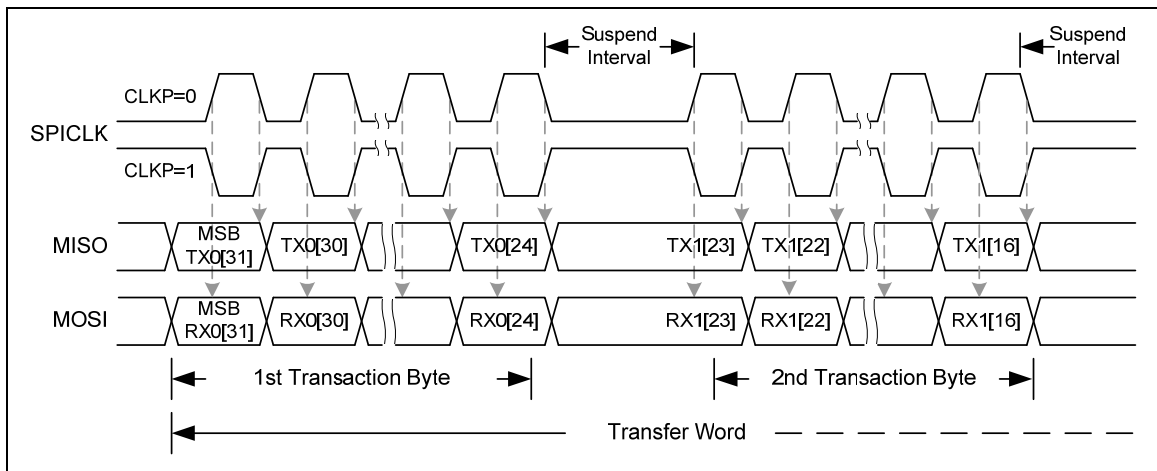

Figure 5-57 Timing Waveform for Byte Suspend

REORDER	Description
00	Disable both byte reorder function and byte suspend interval.
01	Enable byte reorder function and insert a byte suspend interval (2~17 SPICLK) among each byte. The setting of TX_BIT_LEN must be configured as 0x00 ( 32 bits/ word)
10	Enable byte reorder function but disable byte suspend function
11	Disable byte reorder function, but insert a suspend interval (2~17 SPICLK) among each byte. The setting of TX_BIT_LEN must be configured as 0x00 ( 32 bits/ word)

Table 5-7 Byte Order and Byte Suspend Conditions

## Interrupt

Each SPI controller can generate an individual interrupt when data transfer is finished and the respective interrupt event flag IF (SPI\_CNTRL[16]) will be set. The interrupt event flag will generate an interrupt to CPU if the interrupt enable bit IE (SPI\_CNTRL[17]) is set. The interrupt event flag IF can be cleared only by writing 1 to it.

## Two Bit Transfer Mode

This SPI controller also supports two-bit transfer mode when set the TWOB bit (SPI\_CNTRL[22]) to 1. When the TWOB bit is enabled, it can transmit and receives two-bit serial data simultaneously.

For example, in master mode, the data stored at SPI\_TX0 register and SPI\_TX1 register will be transmitted through the MOSIx0 pin and MOSIx1 pin respectively. In the meanwhile, the SPI\_RX0 register and SPI\_RX1 register will store the data received from MISOx0 pin and MISOx1 pin respectively.

In slave mode, the data stored at SPI\_TX0 register and SPI\_TX1 register will be transmitted through the MISOx0 pin and MISOx1 pin respectively. In the meanwhile, the SPI\_RX0 register and SPI\_RX1 register will store the data received from MOSIx0 pin and MOSIx1 pin respectively.

Note that when enable the TWOB bit, the setting of TX\_NUM must be programmed as 0x00 only.

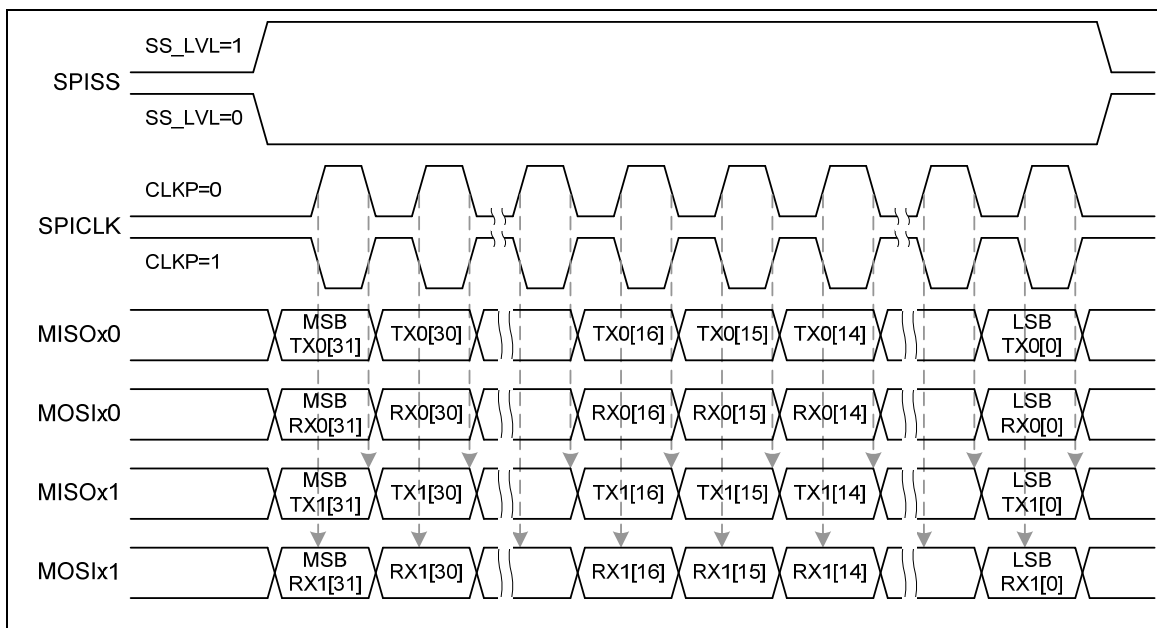

Figure 5-58 Two Bits Transfer Mode (slave mode)

### 5.9.5 Timing Diagram

The active state of slave select signal can be defined by the settings of SS\_LVL bit (SPI\_SSR[2]) and SS\_LTRIG bit (SPI\_SSR[4]). The serial clock (SPICLK) idle state can be configured as high state or low state by setting the CLKP bit (SPI\_CNTRL[11]). It also provides the bit length of a transaction word in TX\_BIT\_LEN (SPI\_CNTRL[7:3]), the transfer number in TX\_NUM (SPI\_CNTRL[8]), and transmit/receive data from MSB or LSB first in LSB bit (SPI\_CNTRL[10]). Users also can select which edge of serial clock to transmit/receive data in TX\_NEG/RX\_NEG (SPI\_CNTRL[2:1]) registers. Four SPI timing diagrams for master/slave operations and the related settings are shown as below.

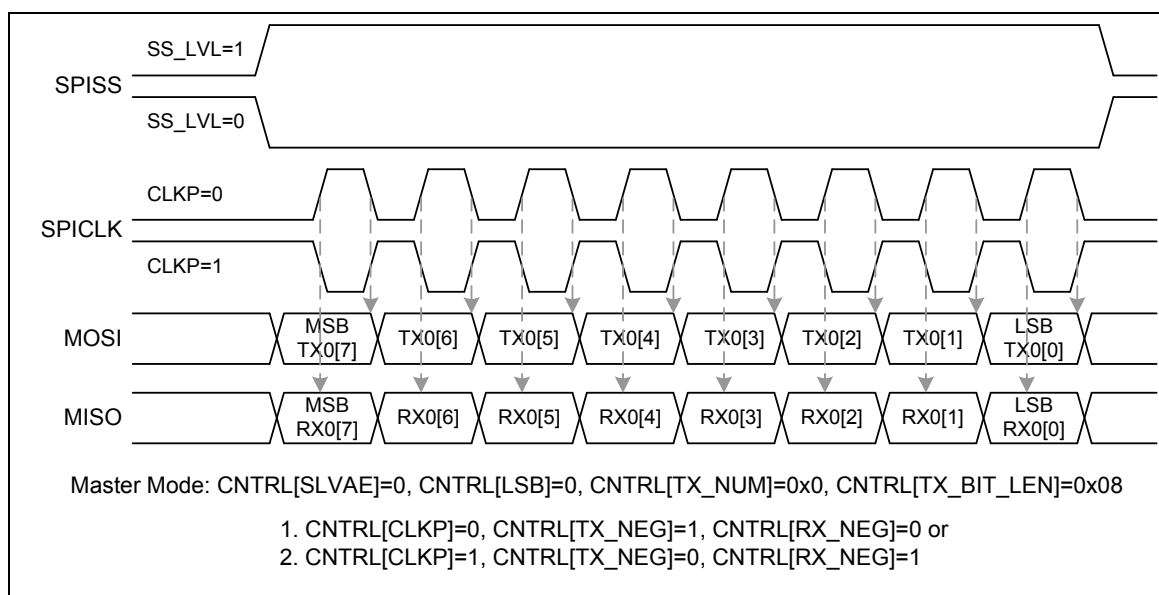

Figure 5-59 SPI Timing in Master Mode

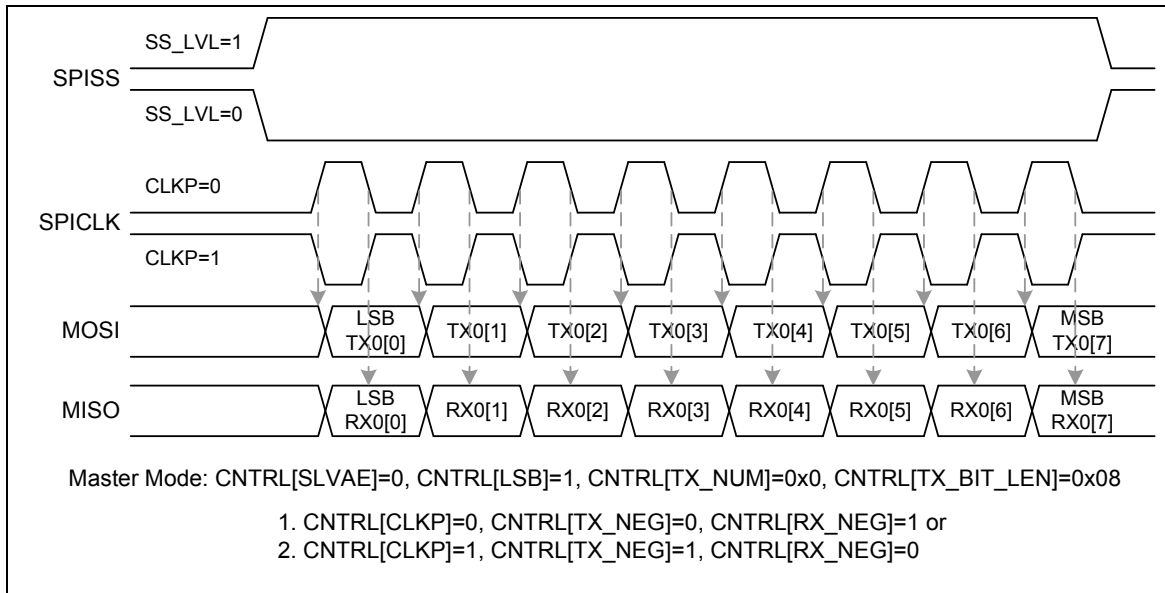

Figure 5-60 SPI Timing in Master Mode (Alternate Phase of SPICLK)

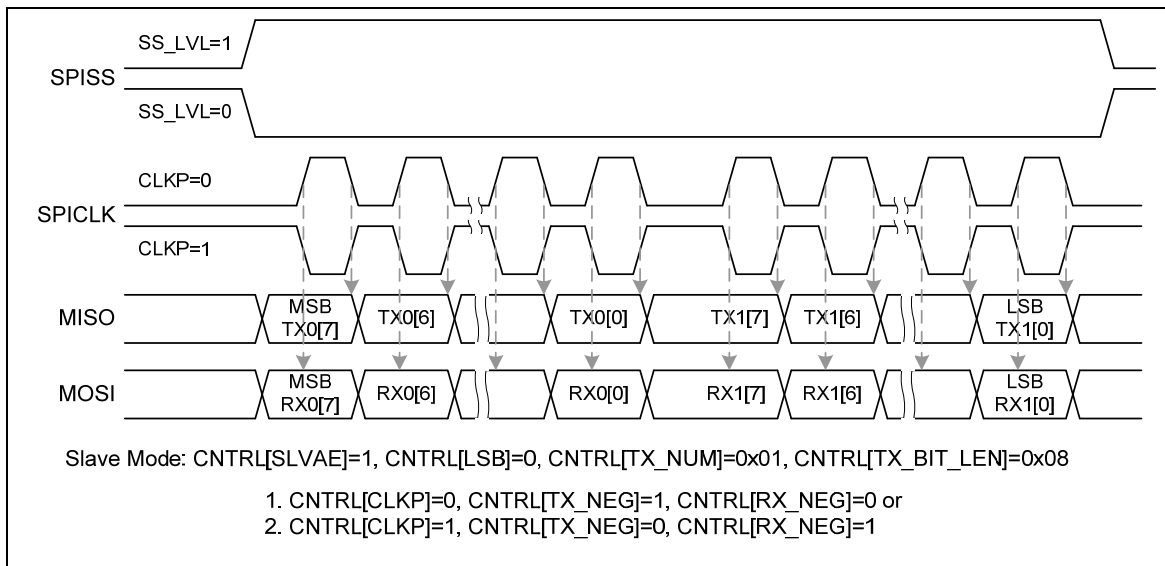

Figure 5-61 SPI Timing in Slave Mode



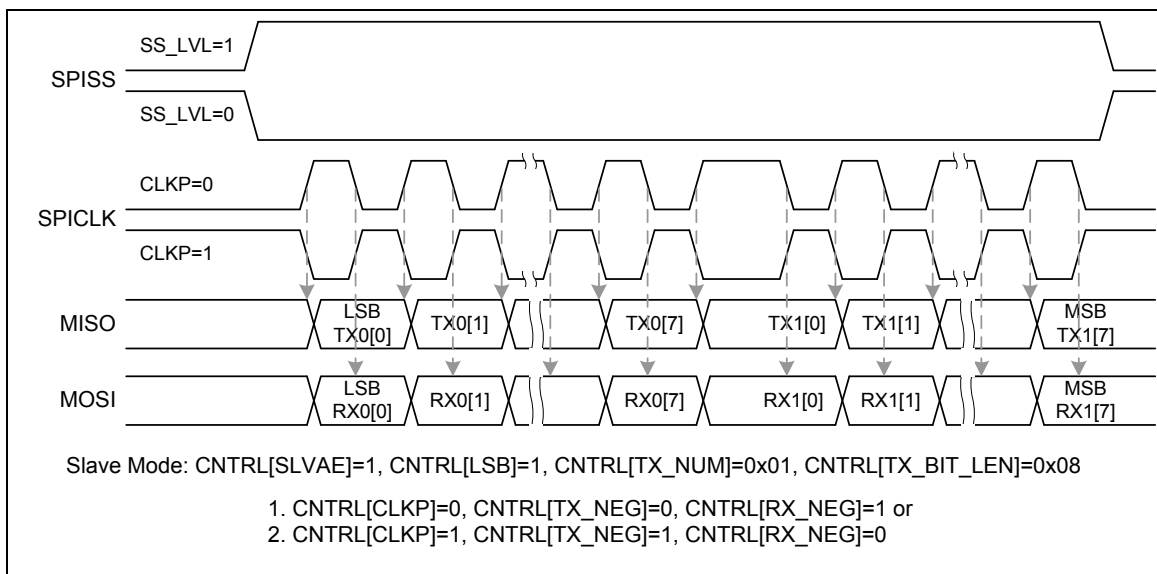

Figure 5-62 SPI Timing in Slave Mode (Alternate Phase of SPICLK)

### 5.9.6 Programming Examples

Example 1, SPI controller is set as a master to access an off-chip slave device with following specifications:

- Data bit is latched on positive edge of serial clock
- Data bit is driven on negative edge of serial clock
- Data is transferred from MSB first
- SPICLK is idle at low state
- Only one byte of data to be transmitted/received in a transaction
- Use the first SPI slave select pin to connect with an off-chip slave device. Slave select signal is active low

The operation flow is as follows.

- 1) Set the DIVIDER (SPI\_DIVIDER [15:0]) register to determine the output frequency of serial clock.
- 2) Write the SPI\_SSR register a proper value for the related settings of master mode
  1. Disable the Automatic Slave Select bit AUTOSS(SPI\_SSR[3] = 0)  
Select low level trigger output of slave select signal in the Slave Select Active Level bit SS\_LVL (SPI\_SSR[2] = 0)
  2. Select slave select signal to be output active at the IO pin by setting the Slave Select Register bits SSR[0] (SPI\_SSR[0]) to active the off-chip slave devices
- 3) Write the related settings into the SPI\_CNTRL register to control this SPI master actions
  1. Set this SPI controller as master device in SLAVE bit (SPI\_CNTRL[18] = 0)
  2. Force the serial clock idle state at low in CLKP bit (SPI\_CNTRL[11] = 0)
  3. Select data transmitted at negative edge of serial clock in TX\_NEG bit (SPI\_CNTRL[2] = 1)
  4. Select data latched at positive edge of serial clock in RX\_NEG bit (SPI\_CNTRL[1] = 0)
  5. Set the bit length of word transfer as 8-bit in TX\_BIT\_LEN bit field (SPI\_CNTRL[7:3] = 0x08)
  6. Set only one time of word transfer in TX\_NUM (SPI\_CNTRL[9:8] = 0x0)
  7. Set MSB transfer first in MSB bit (SPI\_CNTRL[10] = 0), and don't care the SP\_CYCLE bit field (SPI\_CNTRL[15:12]) due to it's not in burst mode in this case
- 4) If this SPI master will transmits (writes) one byte data to the off-chip slave device, write the byte data that will be transmitted into the TX0[7:0] (SPI\_TX0[7:0]) register.
- 5) If this SPI master just only receives (reads) one byte data from the off-chip slave device, you don't need to care what data will be transmitted and just write 0xFF into the SPI\_TX0[7:0] register.
- 6) Enable the GO\_BUSY bit (SPI\_CNTRL [0] = 1) to start the data transfer at the SPI interface.
- 7) Waiting for SPI interrupt occurred (if the Interrupt Enable IE bit is set) or just polling the GO\_BUSY bit till it is cleared to 0 by hardware automatically.

- 8) Read out the received one byte data from RX0 [7:0] (SPI\_RX0[7:0]) register.
- 9) Go to 4) to continue another data transfer or set SSR [0] to 0 to inactivate the off-chip slave devices.

Example 2, The SPI controller is set as a slave device and connects with an off-chip master device. The off-chip master device communicates with the on-chip SPI slave controller through the SPI interface with the following specifications:

- Data bit is latched on positive edge of serial clock
- Data bit is driven on negative edge of serial clock
- Data is transferred from LSB first
- SPICLK is idle at high state
- Only one byte of data to be transmitted/received in a transaction
- Slave select signal is high level trigger

The operation flow is as follows.

- 1) Write the SPI\_SSR register a proper value for the related settings of slave mode
 

Select high level and level trigger for the input of slave select signal by setting the Slave Select Active Level bit SS\_LVL (SPI\_SSR[2] = 1) and the Slave Select Level Trigger bit SS\_LTRIG (SPI\_SSR[4] = 1).
- 2) Write the related settings into the SPI\_CNTRL register to control this SPI slave actions
  1. Set this SPI controller as slave device in SLAVE bit (SPI\_CNTRL[18] = 1)
  2. Select the serial clock idle state at high in CLKP bit (SPI\_CNTRL[11] = 1)
  3. Select data transmitted at negative edge of serial clock in TX\_NEG bit (SPI\_CNTRL[2] = 1)
  4. Select data latched at positive edge of serial clock in RX\_NEG bit (SPI\_CNTRL[1] = 0)
  5. Set the bit length of word transfer as 8-bit in TX\_BIT\_LEN bit field (SPI\_CNTRL[7:3] = 0x08)
  6. Set only one time of word transfer in TX\_NUM (SPI\_CNTRL[9:8] = 0x0)
  7. Set LSB transfer first in LSB bit (SPI\_CNTRL[10] = 1), and don't care the SP\_CYCLE bit field (SPI\_CNTRL[15:12]) due to not burst mode in this case.
- 3) If this SPI slave will transmits (be read) one byte data to the off-chip master device, write the byte data that will be transmitted into the TX0 [7:0] (SPI\_TX0[7:0]) register.
- 4) If this SPI slave just only receives (be written) one byte data from the off-chip master device, you don't care what data will be transmitted and just write 0xFF into the SPI\_TX0[7:0] register.
- 5) Enable the GO\_BUSY bit (SPI\_CNTRL[0] = 1) to wait for the slave select trigger input and serial clock input from the off-chip master device to start the data transfer at the SPI interface.
- 6) Waiting for SPI interrupt occurred (if the Interrupt Enable IE bit is set), or just polling the GO\_BUSY bit till it is cleared to 0 by hardware automatically.



- 7) Read out the received one byte data from RX[7:0] (SPI\_RX0[7:0]) register  
 Go to 3) to continue another data transfer or disable the GO\_BUSY bit to stop data transfer.

## 5.9.7 Register Map

R: read only, W: write only, R/W: both read and write

Register	Offset	R/W	Description	Reset Value
<b>SPI0_BA = 0x4003_0000</b> <b>SPI1_BA = 0x4003_4000</b> <b>SPI2_BA = 0x4013_0000</b> <b>SPI3_BA = 0x4013_4000</b>				
<b>SPI_CNTRL</b>	SPIx_BA+0x00	R/W	Control and Status Register	0x0500_0004
<b>SPI_DIVIDER</b>	SPIx_BA+0x04	R/W	Clock Divider Register	0x0000_0000
<b>SPI_SSR</b>	SPIx_BA+0x08	R/W	Slave Select Register	0x0000_0000
<b>SPI_RX0</b>	SPIx_BA+0x10	R	Data Receive Register 0	0x0000_0000
<b>SPI_RX1</b>	SPIx_BA+0x14	R	Data Receive Register 1	0x0000_0000
<b>SPI_TX0</b>	SPIx_BA+0x20	W	Data Transmit Register 0	0x0000_0000
<b>SPI_TX1</b>	SPIx_BA+0x24	W	Data Transmit Register 1	0x0000_0000
<b>SPI_VARCLK</b>	SPIx_BA+0x34	R/W	Variable Clock Pattern Register	0x007F_FF87
<b>SPI_DMA</b>	SPIx_BA+0x38	R/W	SPI DMA Control Register	0x0000_0000

Note: When software programs CNTRL, the GO\_BUSY bit should be written last.



5.9.8 Register Description

**SPI Control and Status Register (SPI\_CNTRL)**

Register	Offset	R/W	Description	Reset Value
SPI_CNTRL	SPIx_BA+0x00	R/W	Control and Status Register	0x0500_0004

31	30	29	28	27	26	25	24
Reserved							
23	22	21	20	19	18	17	16
VARCLK_EN	TWOB	Reserved	REORDER		SLAVE	IE	IF
15	14	13	12	11	10	9	8
SP_CYCLE				CLKP	LSB	TX_NUM	
7	6	5	4	3	2	1	0
TX_BIT_LEN					TX_NEG	RX_NEG	GO_BUSY

Bits	Descriptions	
[31:24]	Reserved	Reserved
[23]	VARCLK_EN	<p><b>Variable Clock Enable (Master Only)</b></p> <p>1 = The serial clock output frequency is variable. The output frequency is decided by the value of VARCLK, DIVIDER, and DIVIDER2.</p> <p>0 = The serial clock output frequency is fixed and decided only by the value of DIVIDER.</p> <p>Note that when enable this VARCLK_EN bit, the setting of TX_BIT_LEN must be programmed as 0x10 (16-bit mode)</p>
[22]	TWOB	<p><b>Two Bits Transfer Mode Active</b></p> <p>1 = Enable two-bit transfer mode.</p> <p>0 = Disable two-bit transfer mode.</p> <p>Note that when enable TWOB, the serial transmitted 2-bit data output are from SPI_TX1/0, and the received 2-bit data input are put in SPI_RX1/0.</p> <p>Note that when enable TWOB, the setting of TX_NUM must be programmed as 0x00</p>
[21]	Reserved	Reserved. Must be kept as 0.
[20:19]	REORDER	<p><b>Reorder Mode Select</b></p> <p>00 = Disable both byte reorder and byte suspend functions.</p> <p>01 = Enable byte reorder function and insert a byte suspend interval (2~17 SPICLK cycles) among each byte. The setting of TX_BIT_LEN must be configured as 0x00. (32 bits/word)</p> <p>10 = Enable byte reorder function, but disable byte suspend function.</p> <p>11 = Disable byte reorder function, but insert a suspend interval (2~17 SPICLK cycles)</p>



Bits	Descriptions	
		<p>among each byte. The setting of TX_BIT_LEN must be configured as 0x00. (32 bits/word)</p> <p>Note:</p> <ol style="list-style-type: none"> <li>1. Byte reorder function is only available if TX_BIT_LEN is defined as 16, 24, and 32 bits.</li> <li>2. In slave mode with level-trigger configuration, if the byte suspend function is enabled, the slave select pin must be kept at active state during the successive four bytes transfer.</li> </ol>
[18]	<b>SLAVE</b>	<p><b>Slave Mode Enable Bit</b></p> <p>1 = Slave mode 0 = Master mode</p>
[17]	<b>IE</b>	<p><b>Interrupt Enable</b></p> <p>1 = Enable SPI Interrupt 0 = Disable SPI Interrupt</p>
[16]	<b>IF</b>	<p><b>Interrupt Flag</b></p> <p>1 = It indicates that the transfer is done. 0 = It indicates that the transfer dose not finish yet.</p> <p>Note: This bit will be cleared by writing 1 to itself.</p>
[15:12]	<b>SP_CYCLE</b>	<p><b>Suspend Interval (Master Only)</b></p> <p>These four bits provide configurable suspend interval between two successive transmit/receive transaction in a transfer. The suspend interval is from the last falling clock edge of the current transaction to the first rising clock edge of the successive transaction if CLKP = 0. If CLKP = 1, the interval is from the rising clock edge to the falling clock edge. The default value is 0x0. When TX_NUM = 00b, setting this field has no effect on transfer. The desired suspend interval is obtained according to the following equation:</p> <p><math>(SP\_CYCLE[3:0] + 2) * \text{period of SPICLK}</math></p> <p>SP_CYCLE = 0x0 ... 2 SPICLK clock cycle            SP_CYCLE = 0x1 ... 3 SPICLK clock cycle            .....            SP_CYCLE = 0xE ... 16 SPICLK clock cycle            SP_CYCLE = 0xF ... 17 SPICLK clock cycle</p>
[11]	<b>CLKP</b>	<p><b>Clock Polarity</b></p> <p>1 = SPICLK idle high 0 = SPICLK idle low</p>
[10]	<b>LSB</b>	<p><b>LSB First</b></p> <p>1 = The LSB is sent first on the line (bit 0 of SPI_TX0/1), and the first bit received from the line will be put in the LSB position in the RX register (bit 0 of SPI_RX0/1). 0 = The MSB is transmitted/received first (which bit in SPI_TX0/1 and SPI_RX0/1 register that is depends on the TX_BIT_LEN field).</p>
[9:8]	<b>TX_NUM</b>	<p><b>Numbers of Transmit/Receive Word</b></p> <p>This field specifies how many transmit/receive word numbers should be executed in one transfer.</p>



Bits	Descriptions	
		00 = Only one transmit/receive word will be executed in one transfer. 01 = Two successive transmit/receive words will be executed in one transfer. (burst mode) 10 = Reserved. 11 = Reserved. Note: in slave mode with level-trigger configuration, if TX_NUM is set to 01, the slave select pin must be kept at active state during the successive data transfer.
[7:3]	<b>TX_BIT_LEN</b>	<b>Transmit Bit Length</b> This field specifies how many bits can be transmitted / received in one transaction. The minimum bit length is 8 bits and can up to 32 bits. TX_BIT_LEN = 0x08 ... 8 bits ..... TX_BIT_LEN = 0x1F ... 31 bits TX_BIT_LEN = 0x00 ... 32 bits
[2]	<b>TX_NEG</b>	<b>Transmit At Negative Edge</b> 1 = The transmitted data output signal is changed at the falling edge of SPICLK 0 = The transmitted data output signal is changed at the rising edge of SPICLK
[1]	<b>RX_NEG</b>	<b>Receive At Negative Edge</b> 1 = The received data input signal is latched at the falling edge of SPICLK 0 = The received data input signal is latched at the rising edge of SPICLK
[0]	<b>GO_BUSY</b>	<b>Go and Busy Status</b> 1 = In master mode, writing 1 to this bit to start the SPI data transfer; in slave mode, writing 1 to this bit indicates that the slave is ready to communicate with a master. 0 = Writing 0 to this bit to stop data transfer if SPI is transferring. During the data transfer, this bit keeps the value of 1. As the transfer is finished, this bit will be cleared automatically. Note: All registers should be set before writing 1 to this GO_BUSY bit.



## SPI Divider Register (SPI\_DIVIDER)

Register	Offset	R/W	Description	Reset Value
SPI_DIVIDER	SPIx_BA+0x04	R/W	Clock Divider Register (Master Only)	0x0000_0000

31	30	29	28	27	26	25	24
DIVIDER2[15:8]							
23	22	21	20	19	18	17	16
DIVIDER2[7:0]							
15	14	13	12	11	10	9	8
DIVIDER[15:8]							
7	6	5	4	3	2	1	0
DIVIDER[7:0]							

Bits	Descriptions	
[31:16]	<b>DIVIDER2</b>	<p><b>Clock Divider 2</b> (master only)</p> <p>The value in this field is the 2<sup>nd</sup> frequency divider for generating the serial clock on the output SPICLK. The desired frequency is obtained according to the following equation:</p> $f_{skl} = \frac{f_{pclk}}{(DIVIDER2 + 1) * 2}$ <p>If VARCLK_EN is cleared to 0, this setting is unmeaning.</p>
[15:0]	<b>DIVIDER</b>	<p><b>Clock Divider 1</b> (master only)</p> <p>The value in this field is the frequency divider for generating the serial clock on the output SPICLK. The desired frequency is obtained according to the following equation:</p> $f_{skl} = \frac{f_{pclk}}{(DIVIDER + 1) * 2}$ <p>In slave mode, the period of SPI clock driven by a master shall equal or over 5 times the period of PCLK. In other words, the maximum frequency of SPI clock is the fifth of the frequency of slave's PCLK.</p>





## SPI Slave Select Register (SPI SSR)

Register	Offset	R/W	Description	Reset Value
SPI_SSR	SPI0_BA+0x08	R/W	Slave Select Register	0x0000_0000

31	30	29	28	27	26	25	24
Reserved							
23	22	21	20	19	18	17	16
Reserved							
15	14	13	12	11	10	9	8
Reserved							
7	6	5	4	3	2	1	0
Reserved		LTRIG_FLAG	SS_LTRIG	AUTOSS	SS_LVL	SSR	

Bits	Descriptions	
[31:6]	Reserved	Reserved
[5]	LTRIG_FLAG	<p><b>Level Trigger Accomplish Flag</b></p> <p>When the SS_LTRIG bit is set in slave mode, this bit can be read to indicate the received bit number is met the requirement or not.</p> <p>1 = The transaction number and the transferred bit length met the specified requirements which defined in TX_NUM and TX_BIT_LEN.</p> <p>0 = The transaction number or the transferred bit length of one transaction doesn't meet the specified requirements.</p> <p>Note: This bit is READ only</p>
[4]	SS_LTRIG	<p><b>Slave Select Level Trigger Enable Bit (Slave only)</b></p> <p>1 = The slave select signal will be level-trigger. It depends on SS_LVL to decide the signal is active low or active high.</p> <p>0 = The input slave select signal is edge-trigger. This is the default value. It depends on SS_LVL to decide the signal is active at falling-edge or rising-edge</p>
[3]	AUTOSS	<p><b>Automatic Slave Select Enable Bit (Master only)</b></p> <p>1 = If this bit is set, SPISSx0/1 signals will be generated automatically. It means that device/slave select signal, which is set in SSR[1:0], will be asserted by the SPI controller when transmit/receive is started by setting GO_BUSY, and will be de-asserted after each transmit/receive is finished.</p> <p>0 = If this bit is cleared, slave select signals will be asserted/de-asserted by setting /clearing related bits in SSR[1:0].</p>
[2]	SS_LVL	<p><b>Slave Select Active Level</b></p> <p>It defines the active status of slave select signal (SPISSx0/1).</p> <p>1 = The slave select signal SPISSx0/1 is active at high-level/rising-edge.</p> <p>0 = The slave select signal SPISSx0/1 is active at low-level/falling-edge.</p>



Bits	Descriptions	
[1:0]	<b>SSR</b>	<p><b>Slave Select Control Bits (Master only)</b></p> <p>If AUTOSS bit is cleared, writing 1 to any bit location of this field sets the proper SPISSx0/1 line to an active state and writing 0 sets the line back to inactive state.</p> <p>If AUTOSS bit is set, writing 0 to any bit location of this field will keep the corresponding SPISSx0/1 line at inactive state; writing 1 to any bit location of this field will select appropriate SPISSx0/1 line to be automatically driven to active state for the duration of the transmit/receive, and will be driven to inactive state for the rest of the time. The active state of SPISSx0/1 is specified in SS_LVL.</p> <p>Note: SPISSx0 is also defined as slave select input in slave mode.</p>



**SPI Data Receive Register (SPI RX)**

Register	Offset	R/W	Description	Reset Value
SPI_RX0	SPIx_BA+0x10	R	Data Receive Register 0	0x0000_0000
SPI_RX1	SPIx_BA+0x14	R	Data Receive Register 1	0x0000_0000

31	30	29	28	27	26	25	24
RX[31:24]							
23	22	21	20	19	18	17	16
RX[23:16]							
15	14	13	12	11	10	9	8
RX[15:8]							
7	6	5	4	3	2	1	0
RX[7:0]							

Bits	Descriptions	
[31:0]	RX	<p><b>Data Receive Register</b></p> <p>The Data Receive Registers hold the value of received data of the last executed transfer. Valid bits depend on the transmit bit length field in the SPI_CNTRL register.</p> <p>For example, if TX_BIT_LEN is set to 0x08 and TX_NUM is set to 0x0, bit RX0[7:0] holds the received data. The values of the other bits are unknown.</p> <p>Note: The Data Receive Registers are read only registers.</p>



## SPI Data Transmit Register (SPI\_TX)

Register	Offset	R/W	Description	Reset Value
SPI_TX0	SPIx_BA+0x20	W	Data Transmit Register 0	0x0000_0000
SPI_TX1	SPIx_BA+0x24	W	Data Transmit Register 1	0x0000_0000

31	30	29	28	27	26	25	24
TX[31:24]							
23	22	21	20	19	18	17	16
TX[23:16]							
15	14	13	12	11	10	9	8
TX[15:8]							
7	6	5	4	3	2	1	0
TX[7:0]							

Bits	Descriptions
[31:0]	<p><b>Data Transmit Register</b></p> <p>The Data Transmit Registers hold the data to be transmitted in the next transfer. Valid bits depend on the transmit bit length field in the CNTRL register.</p> <p>For example, if TX_BIT_LEN is set to 0x08 and the TX_NUM is set to 0x0, the bit TX0[7:0] will be transmitted in next transfer. If TX_BIT_LEN is set to 0x00 and TX_NUM is set to 0x1, the SPI controller will perform two 32-bit transmit/receive successive using the same setting. The transmission sequence is TX0[31:0] first and then TX1[31:0].</p>



**SPI Variable Clock Pattern Register (SPI\_VARCLK)**

Register	Offset	R/W	Description	Reset Value
SPI_VARCLK	SPIx_BA+0x34	R/W	Variable Clock Pattern Register	0x007F_FF87

31	30	29	28	27	26	25	24
VARCLK[31:24]							
23	22	21	20	19	18	17	16
VARCLK[23:16]							
15	14	13	12	11	10	9	8
VARCLK[15:8]							
7	6	5	4	3	2	1	0
VARCLK[7:0]							

Bits	Descriptions	
[31:0]	VARCLK	<p><b>Variable Clock Pattern</b></p> <p>The value in this field is the frequency patterns of the SPI clock. If the bit pattern of VARCLK is '0', the output frequency of SPICLK is according the value of DIVIDER. If the bit patterns of VARCLK are '1', the output frequency of SPICLK is according the value of DIVIDER2. Refer to register SPI_DIVIDER.</p> <p>Refer to Variable Serial Clock Frequency paragraph for more detail description.</p>



## DMA Control Register (DMACTL)

Register	Offset	R/W	Description	Reset Value
SPI_DMA	SPIx_BA+0x38	R/W	SPI DMA Mode Control Register	0x0000_0000

31	30	29	28	27	26	25	24
Reserved							
23	22	21	20	19	18	17	16
Reserved							
15	14	13	12	11	10	9	8
Reserved							
7	6	5	4	3	2	1	0
Reserved						RX_DMA_GO	TX_DMA_GO

Bits	Descriptions	
[31:2]	Reserved	Reserved
[1]	RX_DMA_GO	<p><b>Receive DMA Start</b></p> <p>Set this bit to 1 will start the receive PDMA process. SPI controller will issue request to PDMA controller automatically.</p> <p>Hardware will clear this bit to 0 automatically after PDMA transfer done.</p>
[0]	TX_DMA_GO	<p><b>Transmit DMA Start</b></p> <p>Set this bit to 1 will start the transmit PDMA process. SPI controller will issue request to PDMA controller automatically.</p> <p>If using PDMA mode to transfer data, remember not to set GO_BUSY bit of SPI_CNTRL register. The DMA controller inside SPI controller will set it automatically whenever necessary.</p> <p>Hardware will clear this bit to 0 automatically after PDMA transfer done.</p> <p>Note: In DMA mode, the burst mode is not supported.</p>



## 5.10 Timer Controller (TMR)

### 5.10.1 Overview

The timer controller includes four 32-bit timers, TIMER0~TIMER3, which allows user to easily implement a timer control for applications. The timer can perform functions like frequency measurement, event counting, interval measurement, clock generation, delay timing, and so on. The timer can generate an interrupt signal upon timeout, or provide the current value during operation. Note: toggle mode, continuous counting mode and event counting function only support in NuMicro™ NUC100/NUC120 Low Density.

### 5.10.2 Features

- 4 sets of 32-bit timers with 24-bit up-timer and one 8-bit pre-scale counter
- Independent clock source for each timer
- Provides one-shot, periodic, toggle and continuous counting operation modes (NuMicro™ NUC100/NUC120 Medium Density only support one-shot and periodic mode)
- Time out period = (Period of timer clock input) \* (8-bit pre-scale counter + 1) \* (24-bit TCMP)
- Maximum counting cycle time =  $(1 / T \text{ MHz}) * (2^8) * (2^{24})$ , T is the period of timer clock
- 24-bit timer value is readable through TDR (Timer Data Register)
- Support event counting function to count the event from external pin (NuMicro™ NUC100/NUC120 Low Density only)



### 5.10.3 Block Diagram

Each channel is equipped with an 8-bit pre-scale counter, a 24-bit up-timer, a 24-bit compare register and an interrupt request signal. Refer to Figure 5-63 for the timer controller block diagram. There are four options of clock sources for each channel. Figure 5-64 illustrates the clock source control function. Software can program the 8-bit pre-scale counter to decide the clock period to 24-bit up timer.

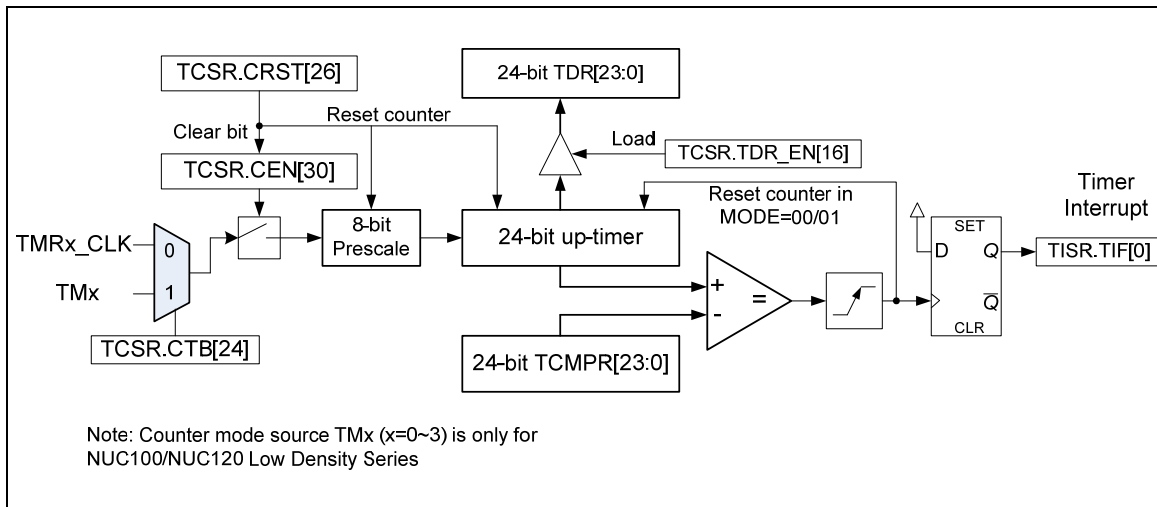

Figure 5-63 Timer Controller Block Diagram

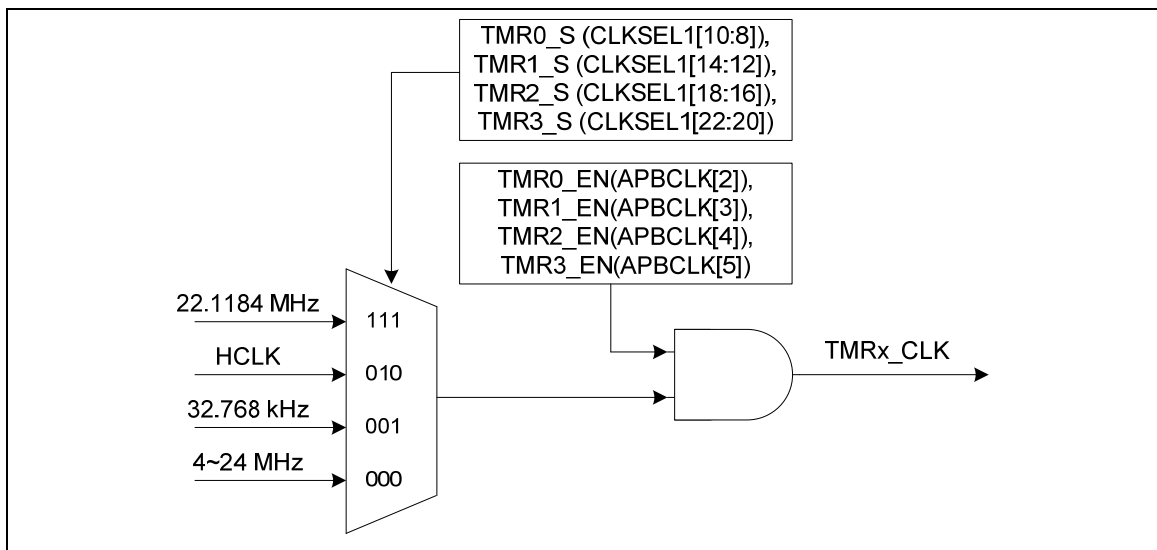

Figure 5-64 Clock Source of Timer Controller





#### 5.10.4 Function Description

Timer controller provides one-shot, period, toggle and continuous counting operation modes. It also provides the event counting function to count the event from external pin. Each operating function mode is shown as following:

##### 5.10.4.1 One –Shot Mode

If timer is operated at one-shot mode and CEN (TCSR[30] timer enable bit) is set to 1, the timer counter starts up counting. Once the timer counter value reaches timer compare register (TCMPR) value, if IE (TCSR[29] interrupt enable bit) is set to 1, then the timer interrupt flag is set and the interrupt signal is generated and sent to NVIC to inform CPU. It indicates that the timer counting overflow happens. If IE (TCSR[29] interrupt enable bit) is set to 0, no interrupt signal is generated. In this operating mode, once the timer counter value reaches timer compare register (TCMPR) value, the timer counter value goes back to counting initial value and CEN (timer enable bit) is cleared to 0 by timer controller. Timer counting operation stops, once the timer counter value reaches timer compare register (TCMPR) value. That is to say, timer operates timer counting and compares with TCMPR value function only one time after programming the timer compare register (TCMPR) value and CEN (timer enable bit) is set to 1. So, this operating mode is called One-Shot mode.

##### 5.10.4.2 Periodic Mode

If timer is operated at period mode and CEN (TCSR[30] timer enable bit) is set to 1, the timer counter starts up counting. Once the timer counter value reaches timer compare register (TCMPR) value, if IE (TCSR[29] interrupt enable bit) is set to 1, then the timer interrupt flag is set and the interrupt signal is generated and sent to NVIC to inform CPU. It indicates that the timer counting overflow happens. If IE (TCSR[29] interrupt enable bit) is set to 0, no interrupt signal is generated. In this operating mode, once the timer counter value reaches timer compare register (TCMPR) value, the timer counter value goes back to counting initial value and CEN is kept at 1 (counting enable continuously). The timer counter operates up counting again. If the interrupt flag is cleared by software, once the timer counter value reaches timer compare register (TCMPR) value and IE (interrupt enable bit) is set to 1'b1, then the timer interrupt flag is set and the interrupt signal is generated and sent to NVIC to inform CPU again. That is to say, timer operates timer counting and compares with TCMPR value function periodically. The timer counting operation doesn't stop until the CEN is set to 0. The interrupt signal is also generated periodically. So, this operating mode is called Periodic mode.

##### 5.10.4.3 Toggle Mode

If timer is operated at toggle mode and CEN (TCSR[30] timer enable bit) is set to 1, the timer counter starts up counting. Once the timer counter value reaches timer compare register (TCMPR) value, if IE (TCSR[29] interrupt enable bit) is set to 1, then the timer interrupt flag is set and the interrupt signal is generated and sent to NVIC to inform CPU. It indicates that the timer counting overflow happens. The associated toggle output (tout) signal is set to 1. In this operating mode, once the timer counter value reaches timer compare register (TCMPR) value, the timer counter value goes back to counting initial value and CEN is kept at 1 (counting enable continuously). The timer counter operates up counting again. If the interrupt flag is cleared by software, once the timer counter value reaches timer compare register (TCMPR) value and IE (interrupt enable bit) is set to 1, then the timer interrupt flag is set and the interrupt signal is generated and sent to NVIC to inform CPU again. The associated toggle output (tout) signal is set to 0. The timer counting operation doesn't stop until the CEN is set to 0. Thus, the toggle output (tout) signal is changing back and forth with 50% duty cycle. So, this operating mode is called Toggle mode.

## 5.10.4.4 Continuous Counting Mode

If the timer is operated at continuous counting mode and CEN (TCSR[30] timer enable bit) is set to 1, the associated interrupt signal is generated depending on  $TDR = TCMPR$  if IE (TCSR[29] interrupt enable bit) is enabled. User can change different TCMPR value immediately without disabling timer counting and restarting timer counting. For example, TCMPR is set as 80, first. (The TCMPR should be less than  $2^{24}$  and be greater than 1). The timer generates the interrupt if IE is enabled and TIF (timer interrupt flag) will set to 1 then the interrupt signal is generated and sent to NVIC to inform CPU when TDR value is equal to 80. But the CEN is kept at 1 (counting enable continuously) and TDR value will not goes back to 0, it continues to count 81, 82, 83, . . . to  $2^{24} - 1$ , 0, 1, 2, 3, . . . to  $2^{24} - 1$  again and again. Next, if user programs TCMPR as 200 and the TIF is cleared to 0, then timer interrupt occurred and TIF is set to 1 then the interrupt signal is generated and sent to NVIC to inform CPU again when TDR value reaches to 200. At last, user programs TCMPR as 500 and clears TIF to 0 again, then timer interrupt occurred and TIF sets to 1 then the interrupt signal is generated and sent to NVIC to inform CPU when TDR value reaches to 500. From application view, the interrupt is generated depending on TCMPR. In this mode, the timer counting is continuous. So, this operation mode is called as continuous counting mode.

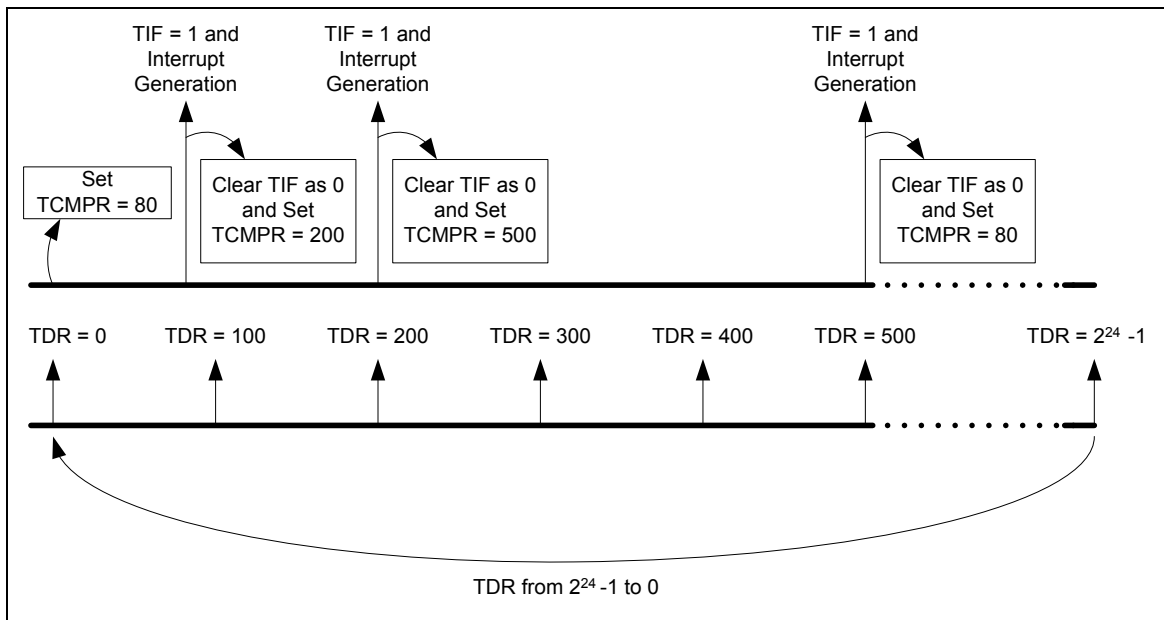

Figure 5-65 Continuous Counting Mode

## 5.10.4.5 Event Counting Function

It also provides an application which can count the event from TM0~TM3 pins. It is called as event counting function. For event counting function, the clock source of timer controller, TMRx\_CLK, in Figure 5-64 should be set as HCLK. And, the event count source operating frequency should be less than 1/3 HCLK frequency



### 5.10.5 Register Map

R: read only, W: write only, R/W: both read and write

Register	Offset	R/W	Description	Reset Value
<b>TMR_BA01 = 0x4001_0000</b>				
<b>TMR_BA23 = 0x4011_0000</b>				
<b>TCSR0</b>	TMR_BA01+0x00	R/W	Timer0 Control and Status Register	0x0000_0005
<b>TCMPR0</b>	TMR_BA01+0x04	R/W	Timer0 Compare Register	0x0000_0000
<b>TISR0</b>	TMR_BA01+0x08	R/W	Timer0 Interrupt Status Register	0x0000_0000
<b>TDR0</b>	TMR_BA01+0x0C	R	Timer0 Data Register	0x0000_0000
<b>TCSR1</b>	TMR_BA01+0x20	R/W	Timer1 Control and Status Register	0x0000_0005
<b>TCMPR1</b>	TMR_BA01+0x24	R/W	Timer1 Compare Register	0x0000_0000
<b>TISR1</b>	TMR_BA01+0x28	R/W	Timer1 Interrupt Status Register	0x0000_0000
<b>TDR1</b>	TMR_BA01+0x2C	R	Timer1 Data Register	0x0000_0000
<b>TCSR2</b>	TMR_BA23+0x00	R/W	Timer2 Control and Status Register	0x0000_0005
<b>TCMPR2</b>	TMR_BA23+0x04	R/W	Timer2 Compare Register	0x0000_0000
<b>TISR2</b>	TMR_BA23+0x08	R/W	Timer2 Interrupt Status Register	0x0000_0000
<b>TDR2</b>	TMR_BA23+0x0C	R	Timer2 Data Register	0x0000_0000
<b>TCSR3</b>	TMR_BA23+0x20	R/W	Timer3 Control and Status Register	0x0000_0005
<b>TCMPR3</b>	TMR_BA23+0x24	R/W	Timer3 Compare Register	0x0000_0000
<b>TISR3</b>	TMR_BA23+0x28	R/W	Timer3 Interrupt Status Register	0x0000_0000
<b>TDR3</b>	TMR_BA23+0x2C	R	Timer3 Data Register	0x0000_0000



5.10.6 Register Description

**Timer Control Register (TCSR)**

Register	Offset	R/W	Description	Reset Value
TCSR0	TMR_BA01+0x00	R/W	Timer0 Control and Status Register	0x0000_0005
TCSR1	TMR_BA01+0x20	R/W	Timer1 Control and Status Register	0x0000_0005
TCSR2	TMR_BA23+0x00	R/W	Timer2 Control and Status Register	0x0000_0005
TCSR3	TMR_BA23+0x20	R/W	Timer3 Control and Status Register	0x0000_0005

31	30	29	28	27	26	25	24
DBGACK_TMR	CEN	IE	MODE[1:0]		CRST	CACT	CTB
23	22	21	20	19	18	17	16
Reserved							TDR_EN
15	14	13	12	11	10	9	8
Reserved							
7	6	5	4	3	2	1	0
PRESCALE[7:0]							

Bits	Descriptions	
[31]	DBGACK_TMR	<p><b>ICE debug mode acknowledge Disable</b> (write-protection bit)</p> <p>0 = ICE debug mode acknowledgement effects TIMER counting.                      TIMER counter will be held while ICE debug mode acknowledged.                      1 = ICE debug mode acknowledgement disabled.                      TIMER counter will keep going no matter ICE debug mode acknowledged or not.</p>
[30]	CEN	<p><b>Timer Enable Bit</b></p> <p>1 = Starts counting                      0 = Stops/Suspends counting</p> <p>Note1: In stop status, and then set CEN to 1 will enables the 24-bit up-timer keeps up counting from the last stop counting value.                      Note2: This bit is auto-cleared by hardware in one-shot mode (MODE [28:27] =00) when the associated timer interrupt is generated (IE [29] =1).</p>
[29]	IE	<p><b>Interrupt Enable Bit</b></p> <p>1 = Enable timer Interrupt                      0 = Disable timer Interrupt</p> <p>If timer interrupt is enabled, the timer asserts its interrupt signal when the associated up-timer value is equal to TCMRPR.</p>



Bits	Descriptions		
[28:27]	<b>MODE</b>	<b>Timer Operating Mode</b>	
		<b>MODE</b>	<b>Timer Operating Mode</b>
		00	The timer is operating at the one-shot mode. The associated interrupt signal is generated once (if IE is enabled) and CEN is automatically cleared by hardware.
		01	The timer is operating at the periodic mode. The associated interrupt signal is generated periodically (if IE is enabled).
		10	The timer is operating at the toggle mode. The interrupt signal is generated periodically (if IE is enabled). And the associated signal (tout) is changing back and forth with 50% duty cycle. (This mode only supported in NuMicro™ NUC100/NUC120 Low Density)
11	The timer is operating at continuous counting mode. The associated interrupt signal is generated when TDR = TCMPR (if IE is enabled). However, the 24-bit up-timer counts continuously. Please refer 5.10.4.4 for detail description about continuous counting mode operation. (This mode only supported in NuMicro™ NUC100/NUC120 Low Density)		
[26]	<b>CRST</b>	<b>Timer Reset Bit</b> Set this bit will reset the 24-bit up-timer, 8-bit pre-scale counter and also force CEN to 0. 0 = No effect 1 = Reset Timer's 8-bit pre-scale counter, internal 24-bit up-timer and CEN bit	
[25]	<b>CACT</b>	<b>Timer Active Status Bit (Read only)</b> This bit indicates the up-timer status. 0 = Timer is not active 1 = Timer is active	
[24]	<b>CTB</b>	<b>Counter Mode Enable Bit (NuMicro™ NUC100/NUC120 Low Density only)</b> This bit is the counter mode enable bit. When Timer is used as an event counter, this bit should be set to 1 and Timer will work as an event counter. The event is triggered by rising edge from external pin 1 = Enable counter mode 0 = Disable counter mode	
[23:17]	<b>Reserved</b>	Reserved	
[16]	<b>TDR_EN</b>	<b>Data Load Enable</b> When TDR_EN is set, TDR (Timer Data Register) will be updated continuously with the 24-bit up-timer value as the timer is counting. 1 = Timer Data Register update enable 0 = Timer Data Register update disable	
[15:8]	<b>Reserved</b>	Reserved	
[7:0]	<b>PRESCALE</b>	<b>Pre-scale Counter</b> Clock input is divided by PRESCALE+1 before it is fed to the counter. If PRESCALE = 0, then there is no scaling.	



## Timer Compare Register (TCMPR)

Register	Offset	R/W	Description	Reset Value
TCMPR0	TMR_BA01+0x04	R/W	Timer0 Compare Register	0x0000_0000
TCMPR1	TMR_BA01+0x24	R/W	Timer1 Compare Register	0x0000_0000
TCMPR2	TMR_BA23+0x04	R/W	Timer2 Compare Register	0x0000_0000
TCMPR3	TMR_BA23+0x24	R/W	Timer3 Compare Register	0x0000_0000

31	30	29	28	27	26	25	24
Reserved							
23	22	21	20	19	18	17	16
TCMP [23:16]							
15	14	13	12	11	10	9	8
TCMP [15:8]							
7	6	5	4	3	2	1	0
TCMP [7:0]							

Bits	Descriptions	
[31:24]	<b>Reserved</b>	Reserved
[23:0]	<b>TCMP</b>	<p><b>Timer Compared Value</b></p> <p>TCMP is a 24-bit compared register. When the internal 24-bit up-timer counts and its value is equal to TCMP value, a Timer Interrupt is requested if the timer interrupt is enabled with TCSR.IE[29]=1. The TCMP value defines the timer counting cycle time.</p> <p>Time out period = (Period of timer clock input) * (8-bit PRESCALE + 1) * (24-bit TCMP)</p> <p>Note1: Never write 0x0 or 0x1 in TCMP, or the core will run into unknown state.</p> <p>Note2: When timer is operating at continuous counting mode, the 24-bit up-timer will count continuously if software writes a new value into TCMP. If timer is operating at other modes, the 24-bit up-timer will restart counting and using newest TCMP value to be the compared value if software writes a new value into TCMP.</p>



## Timer Interrupt Status Register (TISR)

Register	Offset	R/W	Description	Reset Value
TISR0	TMR_BA01+0x08	R/W	Timer0 Interrupt Status Register	0x0000_0000
TISR1	TMR_BA01+0x28	R/W	Timer1 Interrupt Status Register	0x0000_0000
TISR2	TMR_BA23+0x08	R/W	Timer2 Interrupt Status Register	0x0000_0000
TISR3	TMR_BA23+0x28	R/W	Timer3 Interrupt Status Register	0x0000_0000

31	30	29	28	27	26	25	24
Reserved							
23	22	21	20	19	18	17	16
Reserved							
15	14	13	12	11	10	9	8
Reserved							
7	6	5	4	3	2	1	0
Reserved							TIF

Bits	Descriptions	
[31:1]	Reserved	Reserved
[0]	TIF	<p><b>Timer Interrupt Flag</b></p> <p>This bit indicates the interrupt status of Timer.</p> <p>TIF bit is set by hardware when the up counting value of internal 24-bit up-timer matches the timer compared value (TCMP). It is cleared by writing 1 to this bit.</p>



## Timer Data Register (TDR)

Register	Offset	R/W	Description	Reset Value
TDR0	TMR_BA01+0x0C	R	Timer0 Data Register	0x0000_0000
TDR1	TMR_BA01+0x2C	R	Timer1 Data Register	0x0000_0000
TDR2	TMR_BA23+0x0C	R	Timer2 Data Register	0x0000_0000
TDR3	TMR_BA23+0x2C	R	Timer3 Data Register	0x0000_0000

31	30	29	28	27	26	25	24
Reserved							
23	22	21	20	19	18	17	16
TDR[23:16]							
15	14	13	12	11	10	9	8
TDR[15:8]							
7	6	5	4	3	2	1	0
TDR[7:0]							

Bits	Descriptions	
[31:24]	Reserved	Reserved
[23:0]	TDR	<b>Timer Data Register</b> When TCSR.TDR_EN is set to 1, the internal 24-bit up-timer value will be loaded into TDR. User can read this register for the up-timer value.



## 5.11 Watchdog Timer (WDT)

### 5.11.1 Overview

The purpose of Watchdog Timer is to perform a system reset when system runs into an unknown state. This prevents system from hanging for an infinite period of time. Besides, this Watchdog Timer supports another function to wake-up chip from power down mode. The watchdog timer includes an 18-bit free running counter with programmable time-out intervals. Table 5-8 show the watchdog timeout interval selection and Figure 5-64 shows the timing of watchdog interrupt signal and reset signal.

Setting WTE (WDTCR [7]) enables the watchdog timer and the WDT counter starts counting up. When the counter reaches the selected time-out interval, Watchdog timer interrupt flag WTIF will be set immediately to request a WDT interrupt if the watchdog timer interrupt enable bit WTIE is set, in the meanwhile, a specified delay time ( $1024 * T_{WDT}$ ) follows the time-out event. User must set WTR (WDTCR [0]) (Watchdog timer reset) high to reset the 18-bit WDT counter to avoid chip from Watchdog timer reset before the delay time expires. WTR bit is cleared automatically by hardware after WDT counter is reset. There are eight time-out intervals with specific delay time which are selected by Watchdog timer interval select bits WTIS (WDTCR [10:8]). If the WDT counter has not been cleared after the specific delay time expires, the watchdog timer will set Watchdog Timer Reset Flag (WTRF) high and reset chip. This reset will last 63 WDT clocks ( $T_{RST}$ ) then chip restarts executing program from reset vector (0x0000\_0000). WTRF will not be cleared by Watchdog reset. User may poll WTRF by software to recognize the reset source. WDT also provides wake-up function. When chip is powered down and the Watchdog Timer Wake-up Function Enable bit (WDTR[4]) is set, if the WDT counter reaches the specific time interval defined by WTIS (WDTCR [10:8]), the chip is waken up from power down state. First example, if WTIS is set as 000, the specific time interval for chip to wake up from power down state is  $2^4 * T_{WDT}$ . When power down command is set by software, then, chip enters power down state. After  $2^4 * T_{WDT}$  time is elapsed, chip is waken up from power down state. Second example, if WTIS (WDTCR [10:8]) is set as 111, the specific time interval for chip to wake up from power down state is  $2^{18} * T_{WDT}$ . If power down command is set by software, then, chip enters power down state. After  $2^{18} * T_{WDT}$  time is elapsed, chip is waken up from power down state. Notice if WTRE (WDTCR [1]) is set to 1, after chip is waken up, software should clear the Watchdog Timer counter by setting WTR(WDTCR [0]) to 1 as soon as possible. Otherwise, if the Watchdog Timer counter is not cleared by setting WTR (WDTCR [0]) to 1 before time starting from waking up to software clearing Watchdog Timer counter is over  $1024 * T_{WDT}$ , the chip is reset by Watchdog Timer.

WTIS	Timeout Interval Selection $T_{TIS}$	Interrupt Period $T_{INT}$	WTR Timeout Interval (WDT_CLK=10 kHz) Min. $T_{WTR}$ ~ Max. $T_{WTR}$
000	$2^4 * T_{WDT}$	$1024 * T_{WDT}$	1.6 ms ~ 104 ms
001	$2^6 * T_{WDT}$	$1024 * T_{WDT}$	6.4 ms ~ 108.8 ms
010	$2^8 * T_{WDT}$	$1024 * T_{WDT}$	25.6 ms ~ 128 ms
011	$2^{10} * T_{WDT}$	$1024 * T_{WDT}$	102.4 ms ~ 204.8 ms
100	$2^{12} * T_{WDT}$	$1024 * T_{WDT}$	409.6 ms ~ 512 ms
101	$2^{14} * T_{WDT}$	$1024 * T_{WDT}$	1.6384 s ~ 1.7408 s
110	$2^{16} * T_{WDT}$	$1024 * T_{WDT}$	6.5536 s ~ 6.656 s
111	$2^{18} * T_{WDT}$	$1024 * T_{WDT}$	26.2144 s ~ 26.3168 s

Table 5-8 Watchdog Timeout Interval Selection

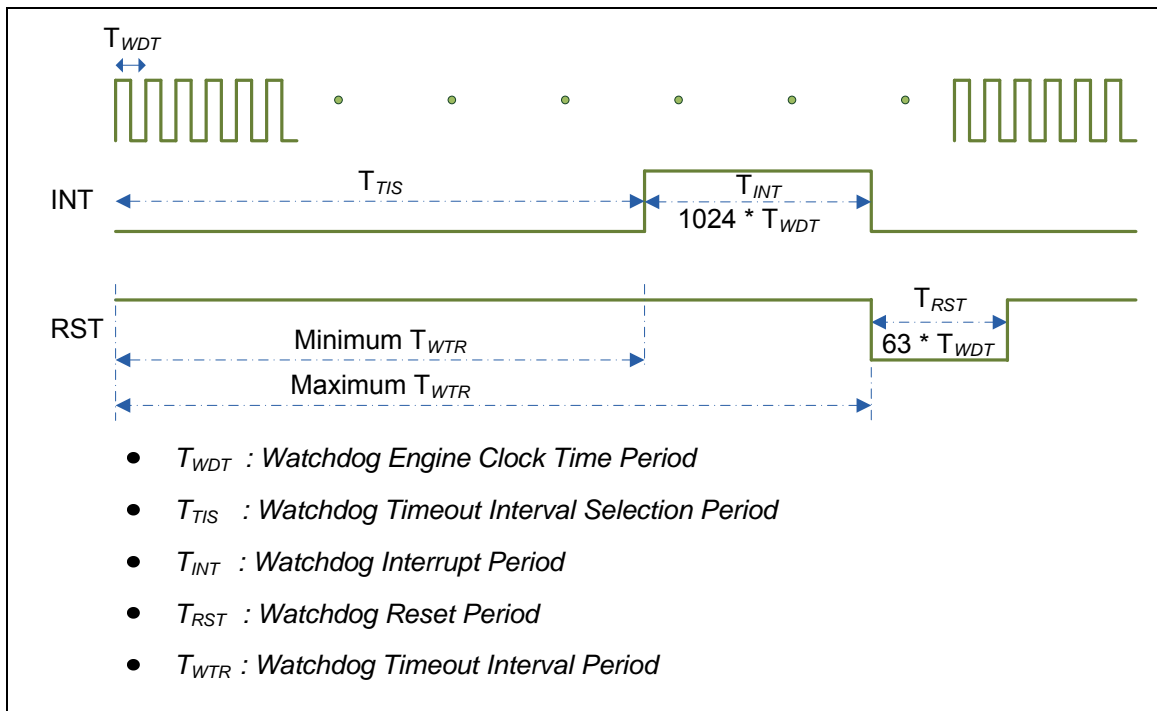

Figure 5-66 Timing of Interrupt and Reset Signal

## 5.11.2 Features

- 18-bit free running counter to avoid chip from Watchdog timer reset before the delay time expires.
- Selectable time-out interval ( $2^4 \sim 2^{18}$ ) and the time out interval is 104 ms ~ 26.3168 s (if WDT\_CLK = 10 kHz).
- Reset period =  $(1 / 10 \text{ kHz}) * 63$ , if WDT\_CLK = 10 kHz.

## 5.11.3 Block Diagram

The Watchdog Timer clock control and block diagram are shown as following.

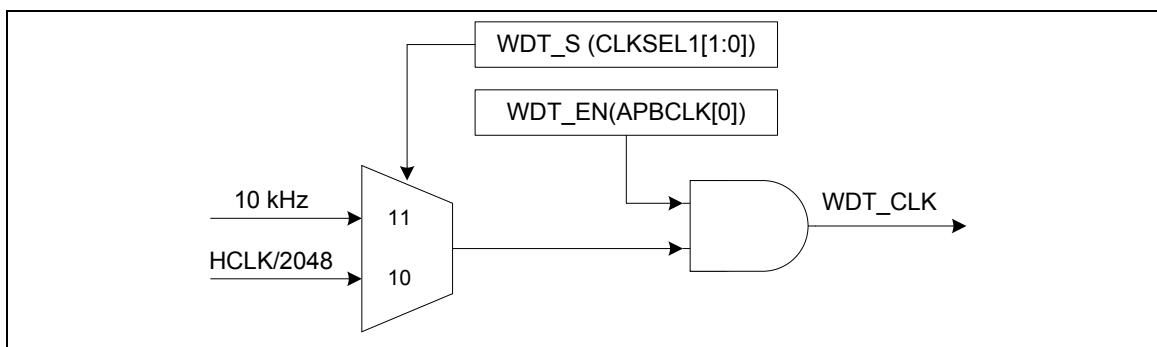

Figure 5-67 Watchdog Timer Clock Control

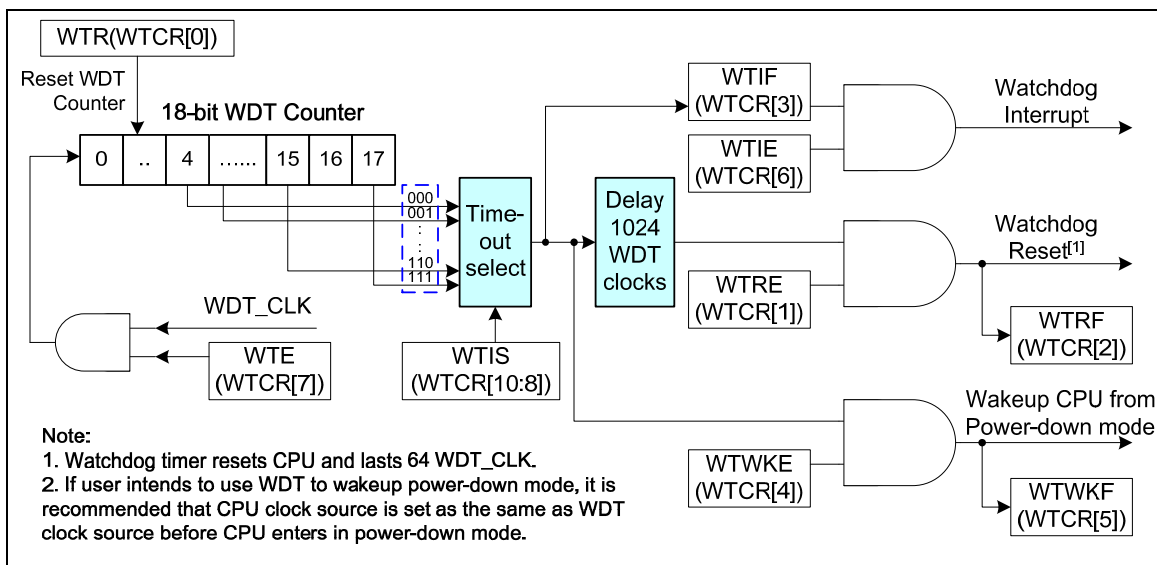

Figure 5-68 Watchdog Timer Block Diagram



#### 5.11.4 Register Map

R: read only, W: write only, R/W: both read and write

Register	Offset	R/W	Description	Reset Value
<b>WDT_BA = 0x4000_4000</b>				
<b>WTCR</b>	WDT_BA+0x00	R/W	Watchdog Timer Control Register	0x0000_0700



## 5.11.5 Register Description

### Watchdog Timer Control Register (WTCR)

Register	Offset	R/W	Description	Reset Value
<b>WTCR</b>	WDT_BA+0x00	R/W	Watchdog Timer Control Register	0x0000_0700

Note: All bits can be write in this register are write-protected. To program it needs to write "59h", "16h", "88h" to address 0x5000\_0100 to disable register protection. Reference the register REGWRPROT at address GCR\_BA+0x100.

31	30	29	28	27	26	25	24
<b>DBGACK_WDT</b>	<b>Reserved</b>						
23	22	21	20	19	18	17	16
<b>Reserved</b>							
15	14	13	12	11	10	9	8
<b>Reserved</b>					<b>WTIS</b>		
7	6	5	4	3	2	1	0
<b>WTE</b>	<b>WTIE</b>	<b>WTWKF</b>	<b>WTWKE</b>	<b>WTIF</b>	<b>WTRF</b>	<b>WTRE</b>	<b>WTR</b>

Bits	Descriptions																																	
[31]	<b>DBGACK_WDT</b>	<p><b>ICE debug mode acknowledge Disable</b> (write-protection bit)</p> <p>0 = ICE debug mode acknowledgement effects Watchdog Timer counting. Watchdog Timer counter will be held while ICE debug mode acknowledged.</p> <p>1 = ICE debug mode acknowledgement disabled. Watchdog Timer counter will keep going no matter ICE debug mode acknowledged or not.</p>																																
[30:11]	<b>Reserved</b>	Reserved																																
[10:8]	<b>WTIS</b>	<p><b>Watchdog Timer Interval Select</b> (write-protection bits)</p> <p>These three bits select the timeout interval for the Watchdog timer.</p> <table border="1" style="width: 100%; border-collapse: collapse;"> <thead> <tr> <th>WTIS</th> <th>Timeout Interval Selection</th> <th>Interrupt Period</th> <th>WTR Timeout Interval (WDT_CLK=10 kHz)</th> </tr> </thead> <tbody> <tr> <td>000</td> <td><math>2^4 * T_{WDT}</math></td> <td><math>1024 * T_{WDT}</math></td> <td>1.6 ms ~ 104 ms</td> </tr> <tr> <td>001</td> <td><math>2^6 * T_{WDT}</math></td> <td><math>1024 * T_{WDT}</math></td> <td>6.4 ms ~ 108.8 ms</td> </tr> <tr> <td>010</td> <td><math>2^8 * T_{WDT}</math></td> <td><math>1024 * T_{WDT}</math></td> <td>25.6 ms ~ 128 ms</td> </tr> <tr> <td>011</td> <td><math>2^{10} * T_{WDT}</math></td> <td><math>1024 * T_{WDT}</math></td> <td>102.4 ms ~ 204.8 ms</td> </tr> <tr> <td>100</td> <td><math>2^{12} * T_{WDT}</math></td> <td><math>1024 * T_{WDT}</math></td> <td>409.6 ms ~ 512 ms</td> </tr> <tr> <td>101</td> <td><math>2^{14} * T_{WDT}</math></td> <td><math>1024 * T_{WDT}</math></td> <td>1.6384 s ~ 1.7408 s</td> </tr> <tr> <td>110</td> <td><math>2^{16} * T_{WDT}</math></td> <td><math>1024 * T_{WDT}</math></td> <td>6.5536 s ~ 6.656 s</td> </tr> </tbody> </table>	WTIS	Timeout Interval Selection	Interrupt Period	WTR Timeout Interval (WDT_CLK=10 kHz)	000	$2^4 * T_{WDT}$	$1024 * T_{WDT}$	1.6 ms ~ 104 ms	001	$2^6 * T_{WDT}$	$1024 * T_{WDT}$	6.4 ms ~ 108.8 ms	010	$2^8 * T_{WDT}$	$1024 * T_{WDT}$	25.6 ms ~ 128 ms	011	$2^{10} * T_{WDT}$	$1024 * T_{WDT}$	102.4 ms ~ 204.8 ms	100	$2^{12} * T_{WDT}$	$1024 * T_{WDT}$	409.6 ms ~ 512 ms	101	$2^{14} * T_{WDT}$	$1024 * T_{WDT}$	1.6384 s ~ 1.7408 s	110	$2^{16} * T_{WDT}$	$1024 * T_{WDT}$	6.5536 s ~ 6.656 s
WTIS	Timeout Interval Selection	Interrupt Period	WTR Timeout Interval (WDT_CLK=10 kHz)																															
000	$2^4 * T_{WDT}$	$1024 * T_{WDT}$	1.6 ms ~ 104 ms																															
001	$2^6 * T_{WDT}$	$1024 * T_{WDT}$	6.4 ms ~ 108.8 ms																															
010	$2^8 * T_{WDT}$	$1024 * T_{WDT}$	25.6 ms ~ 128 ms																															
011	$2^{10} * T_{WDT}$	$1024 * T_{WDT}$	102.4 ms ~ 204.8 ms																															
100	$2^{12} * T_{WDT}$	$1024 * T_{WDT}$	409.6 ms ~ 512 ms																															
101	$2^{14} * T_{WDT}$	$1024 * T_{WDT}$	1.6384 s ~ 1.7408 s																															
110	$2^{16} * T_{WDT}$	$1024 * T_{WDT}$	6.5536 s ~ 6.656 s																															



Bits	Descriptions				
		111	$2^{18} * T_{WDT}$	$1024 * T_{WDT}$	26.2144 s ~ 26.3168 s
[7]	<b>WTE</b>	<b>Watchdog Timer Enable</b> (write-protection bit) 0 = Disable the Watchdog timer (This action will reset the internal counter) 1 = Enable the Watchdog timer			
[6]	<b>WTIE</b>	<b>Watchdog Timer Interrupt Enable</b> (write-protection bit) 0 = Disable the Watchdog timer interrupt 1 = Enable the Watchdog timer interrupt			
[5]	<b>WTWKF</b>	<b>Watchdog Timer Wake-up Flag</b> If Watchdog timer causes chip wakes up from power down mode, this bit will be set to high. It must be cleared by software with a write 1 to this bit. 0 = Watchdog timer does not cause chip wake-up. 1 = Chip wake-up from idle or power down mode by Watchdog timeout.			
[4]	<b>WTWKE</b>	<b>Watchdog Timer Wake-up Function Enable bit</b> (write-protection bit) 0 = Disable Watchdog timer Wake-up chip function. 1 = Enable the Wake-up function that Watchdog timer timeout can wake-up chip from power down mode. Note: Chip can wake-up by WDT only if WDT clock source select RC10K			
[3]	<b>WTIF</b>	<b>Watchdog Timer Interrupt Flag</b> If the Watchdog timer interrupt is enabled, then the hardware will set this bit to indicate that the Watchdog timer interrupt has occurred. 0 = Watchdog timer interrupt did not occur 1 = Watchdog timer interrupt occurs Note: This bit is cleared by writing 1 to this bit.			
[2]	<b>WTRF</b>	<b>Watchdog Timer Reset Flag</b> When the Watchdog timer initiates a reset, the hardware will set this bit. This flag can be read by software to determine the source of reset. Software is responsible to clear it manually by writing 1 to it. If WTRE is disabled, then the Watchdog timer has no effect on this bit. 0 = Watchdog timer reset did not occur 1 = Watchdog timer reset occurs Note: This bit is cleared by writing 1 to this bit.			
[1]	<b>WTRE</b>	<b>Watchdog Timer Reset Enable</b> (write-protection bit) Setting this bit will enable the Watchdog timer reset function. 0 = Disable Watchdog timer reset function 1 = Enable Watchdog timer reset function			
[0]	<b>WTR</b>	<b>Clear Watchdog Timer</b> (write-protection bit) Set this bit will clear the Watchdog timer. 0 = Writing 0 to this bit has no effect 1 = Reset the contents of the Watchdog timer Note: This bit will be auto cleared by hardware			



## 5.12 UART Interface Controller (UART)

NuMicro™ NUC100/NUC120 Medium Density provides up to three channels of Universal Asynchronous Receiver/Transmitters (UART). UART0 supports High Speed UART and UART1~2 perform Normal Speed UART, besides, only UART0 and UART1 support flow control function. NuMicro™ NUC100/NUC120 Low Density only supports UART0 and UART1.

### 5.12.1 Overview

The Universal Asynchronous Receiver/Transmitter (UART) performs a serial-to-parallel conversion on data received from the peripheral, and a parallel-to-serial conversion on data transmitted from the CPU. The UART controller also supports IrDA SIR Function and RS-485 mode functions. Each UART channel supports seven types of interrupts including transmitter FIFO empty interrupt (INT\_THRE), receiver threshold level reaching interrupt (INT\_RDA), line status interrupt (parity error or framing error or break interrupt) (INT\_RLS), receiver buffer time out interrupt (INT\_TOUT), MODEM/Wake-up status interrupt (INT\_MODEM) and Buffer error interrupt (INT\_BUF\_ERR). Interrupts of UART0 and UART2 share the interrupt number 12 (vector number is 28); Interrupt number 13 (vector number is 29) only supports UART1 interrupt. Refer to Nested Vectored Interrupt Controller chapter for System Interrupt Map.

The UART0 is built-in with a 64-byte transmitter FIFO (TX\_FIFO) and a 64-byte receiver FIFO (RX\_FIFO) that reduces the number of interrupts presented to the CPU and the UART1~2 are equipped 16-byte transmitter FIFO (TX\_FIFO) and 16-byte receiver FIFO (RX\_FIFO). The CPU can read the status of the UART at any time during the operation. The reported status information includes the type and condition of the transfer operations being performed by the UART, as well as 4 error conditions (parity error, framing error, break interrupt and buffer error) probably occur while receiving data. The UART includes a programmable baud rate generator that is capable of dividing clock input by divisors to produce the serial clock that transmitter and receiver need. The baud rate equation is  $\text{Baud Rate} = \text{UART\_CLK} / M * [\text{BRD} + 2]$ , where M and BRD are defined in Baud Rate Divider Register (UA\_BAUD). Table 5-9 lists the equations in the various conditions and Table 5-10 list the UART baud rate setting table.

Mode	DIV_X_EN	DIV_X_ONE	Divider X	BRD	Baud rate equation
0	0	0	B	A	$\text{UART\_CLK} / [16 * (A+2)]$
1	1	0	B	A	$\text{UART\_CLK} / [(B+1) * (A+2)]$ , B must $\geq 8$
2	1	1	Don't care	A	$\text{UART\_CLK} / (A+2)$ , A must $\geq 3$

Table 5-9 UART Baud Rate Equation

System clock = Internal 22.1184 MHz high speed oscillator						
Baud rate	Mode0		Mode1		Mode2	
	Parameter	Register	Parameter	Register	Parameter	Register
921600	x	x	A=0,B=11	0x2B00_0000	A=22	0x3000_0016
460800	A=1	0x0000_0001	A=1,B=15 A=2,B=11	0x2F00_0001 0x2B00_0002	A=46	0x3000_002E



System clock = Internal 22.1184 MHz high speed oscillator						
Baud rate	Mode0		Mode1		Mode2	
	Parameter	Register	Parameter	Register	Parameter	Register
230400	A=4	0x0000_0004	A=4,B=15 A=6,B=11	0x2F00_0004 0x2B00_0006	A=94	0x3000_005E
115200	A=10	0x0000_000A	A=10,B=15 A=14,B=11	0x2F00_000A 0x2B00_000E	A=190	0x3000_00BE
57600	A=22	0x0000_0016	A=22,B=15 A=30,B=11	0x2F00_0016 0x2B00_001E	A=382	0x3000_017E
38400	A=34	0x0000_0022	A=62,B=8 A=46,B=11 A=34,B=15	0x2800_003E 0x2B00_002E 0x2F00_0022	A=574	0x3000_023E
19200	A=70	0x0000_0046	A=126,B=8 A=94,B=11 A=70,B=15	0x2800_007E 0x2B00_005E 0x2F00_0046	A=1150	0x3000_047E
9600	A=142	0x0000_008E	A=254,B=8 A=190,B=11 A=142,B=15	0x2800_00FE 0x2B00_00BE 0x2F00_008E	A=2302	0x3000_08FE
4800	A=286	0x0000_011E	A=510,B=8 A=382,B=11 A=286,B=15	0x2800_01FE 0x2B00_017E 0x2F00_011E	A=4606	0x3000_11FE

Table 5-10 UART Baud Rate Setting Table

The UART0 and UART1 controllers support auto-flow control function that uses two low-level signals, /CTS (clear-to-send) and /RTS (request-to-send), to control the flow of data transfer between the UART and external devices (ex: Modem). When auto-flow is enabled, the UART is not allowed to receive data until the UART asserts /RTS to external device. When the number of bytes in the RX FIFO equals the value of RTS\_TRI\_LEV (UA\_FCR [19:16]), the /RTS is de-asserted. The UART sends data out when UART controller detects /CTS is asserted from external device. If a valid asserted /CTS is not detected the UART controller will not send data out.

The UART controllers also provides Serial IrDA (SIR, Serial Infrared) function (User must set IrDA\_EN (UA\_FUN\_SEL [1]) to enable IrDA function). The SIR specification defines a short-range infrared asynchronous serial transmission mode with one start bit, 8 data bits, and 1 stop bit. The maximum data rate is 115.2 Kbps (half duplex). The IrDA SIR block contains an IrDA SIR Protocol encoder/decoder. The IrDA SIR protocol is half-duplex only. So it cannot transmit and receive data at the same time. The IrDA SIR physical layer specifies a minimum 10ms transfer delay between transmission and reception. This delay feature must be implemented by software.

For NuMicro™ NUC100/NUC120 Low Density, another alternate function of UART controllers is RS-485 9-bit mode function, and direction control provided by RTS pin or can program GPIO (PB.2 for RTS0 and PB.6 for RTS1) to implement the function by software. The RS-485 mode is selected by setting the UA\_FUN\_SEL register to select RS-485 function. The RS-485 driver control is implemented using the RTS control signal from an asynchronous serial port to enable the RS-485 driver. In RS-485 mode, many characteristics of the RX and TX are same as UART.



## 5.12.2 Features

- Full duplex, asynchronous communications
- Separate receive / transmit 64/16/16 bytes (UART0/UART1/UART2) entry FIFO for data payloads
- Support hardware auto flow control/flow control function (CTS, RTS) and programmable RTS flow control trigger level (UART0 and UART1 support)
- Programmable receiver buffer trigger level
- Support programmable baud-rate generator for each channel individually
- Support CTS wake-up function (UART0 and UART1 support)
- Support 7-bit receiver buffer time out detection function
- UART0/UART1 can be served by the DMA controller
- Programmable transmitting data delay time between the last stop and the next start bit by setting UA\_TOR [DLY] register
- Support break error, frame error, parity error and receive / transmit buffer overflow detect function
- Fully programmable serial-interface characteristics
  - Programmable number of data bit, 5-, 6-, 7-, 8-bit character
  - Programmable parity bit, even, odd, no parity or stick parity bit generation and detection
  - Programmable stop bit, 1, 1.5, or 2 stop bit generation
- Support IrDA SIR function mode
  - Support for 3-/16-bit duration for normal mode
- Support RS-485 function mode. (NuMicro™ NUC100/NUC120 Low Density only)
  - Support RS-485 9-bit mode
  - Support hardware or software direct enable control provided by RTS pin

### 5.1.2.3 Block Diagram

The UART clock control and block diagram are shown as Figure 5-67 and Figure 5-68.

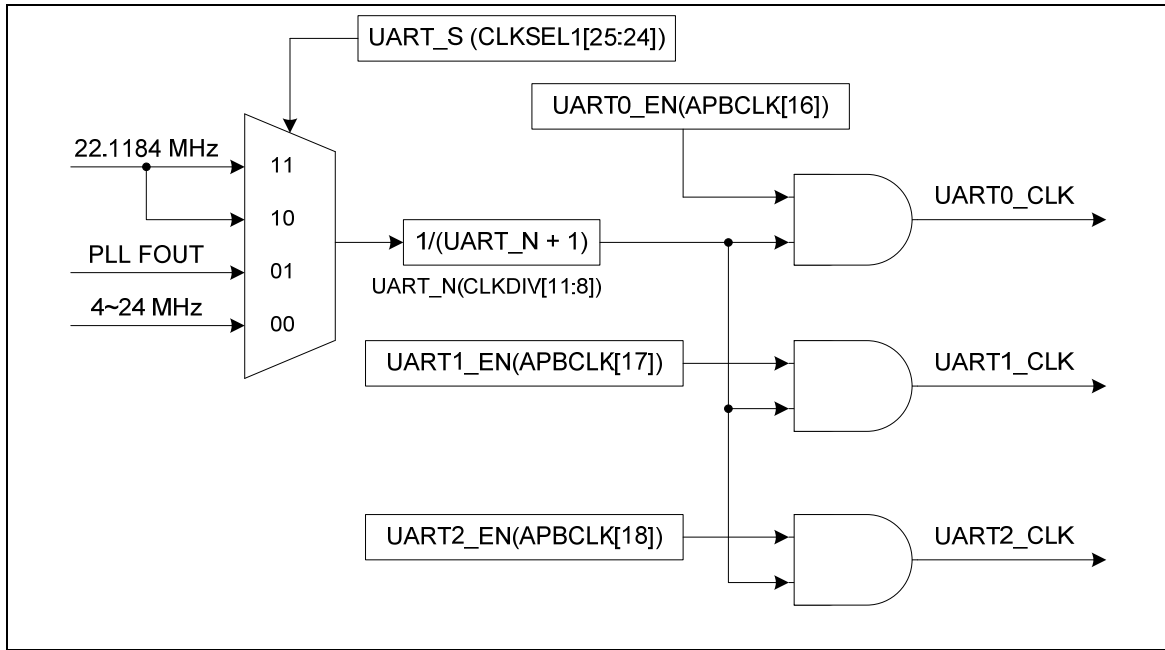

Figure 5-69 UART Clock Control Diagram

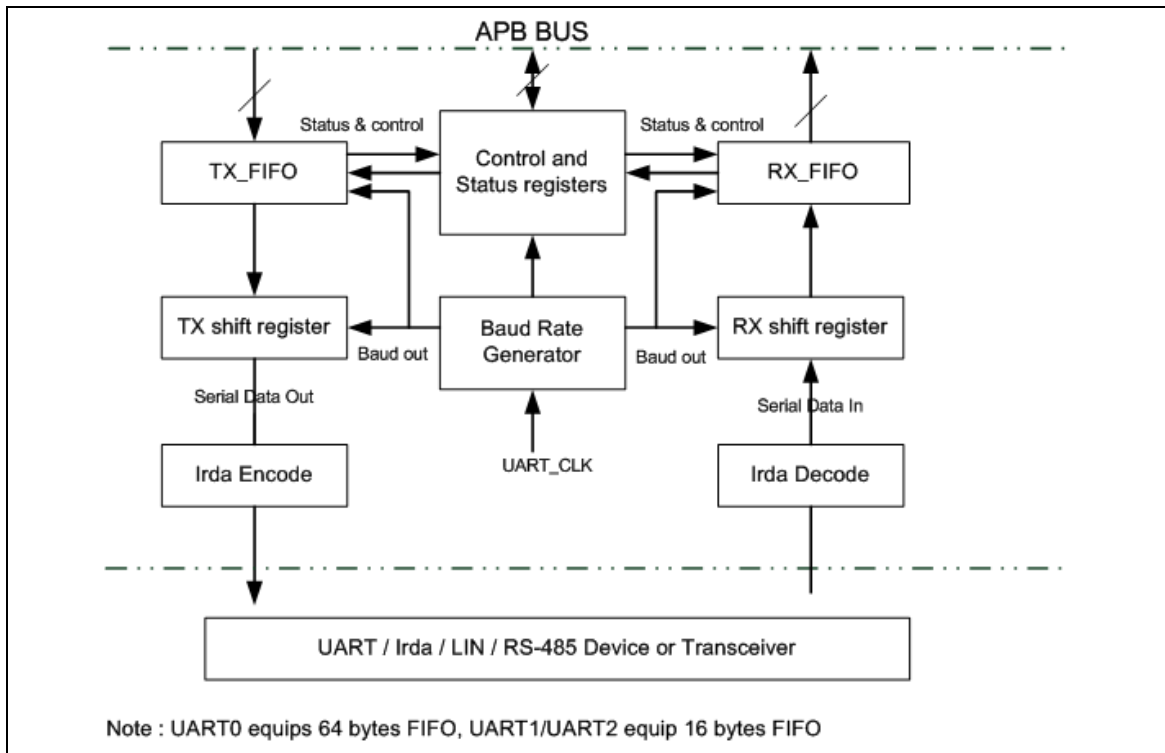

Figure 5-70 UART Block Diagram



## **TX\_FIFO**

The transmitter is buffered with a 64/16 byte FIFO to reduce the number of interrupts presented to the CPU.

## **RX\_FIFO**

The receiver is buffered with a 64/16 byte FIFO (plus three error bits per byte) to reduce the number of interrupts presented to the CPU.

## **TX shift Register**

This block is the shifting the transmitting data out serially control block.

## **RX shift Register**

This block is the shifting the receiving data in serially control block.

## **Modem Control Register**

This register controls the interface to the MODEM or data set (or a peripheral device emulating a MODEM).

## **Baud Rate Generator**

Divide the external clock by the divisor to get the desired baud rate clock. Refer to baud rate equation.

## **IrDA Encode**

This block is IrDA encode control block.

## **IrDA Decode**

This block is IrDA decode control block.

## **Control and Status Register**

This field is register set that including the FIFO control registers (UA\_FCR), FIFO status registers (UA\_FSR), and line control register (UA\_LCR) for transmitter and receiver. The time out control register (UA\_TOR) identifies the condition of time out interrupt. This register set also includes the interrupt enable register (UA\_IER) and interrupt status register (UA\_ISR) to enable or disable the responding interrupt and to identify the occurrence of the responding interrupt. There are seven types of interrupts, transmitter FIFO empty interrupt(INT\_THRE), receiver threshold level reaching interrupt (INT\_RDA), line status interrupt (parity error or framing error or break interrupt) (INT\_RLS) , time out interrupt (INT\_TOUT), MODEM/Wake-up status interrupt (INT\_MODEM) and Buffer error interrupt (INT\_BUF\_ERR).

The following diagram demonstrates the auto-flow control block diagram.

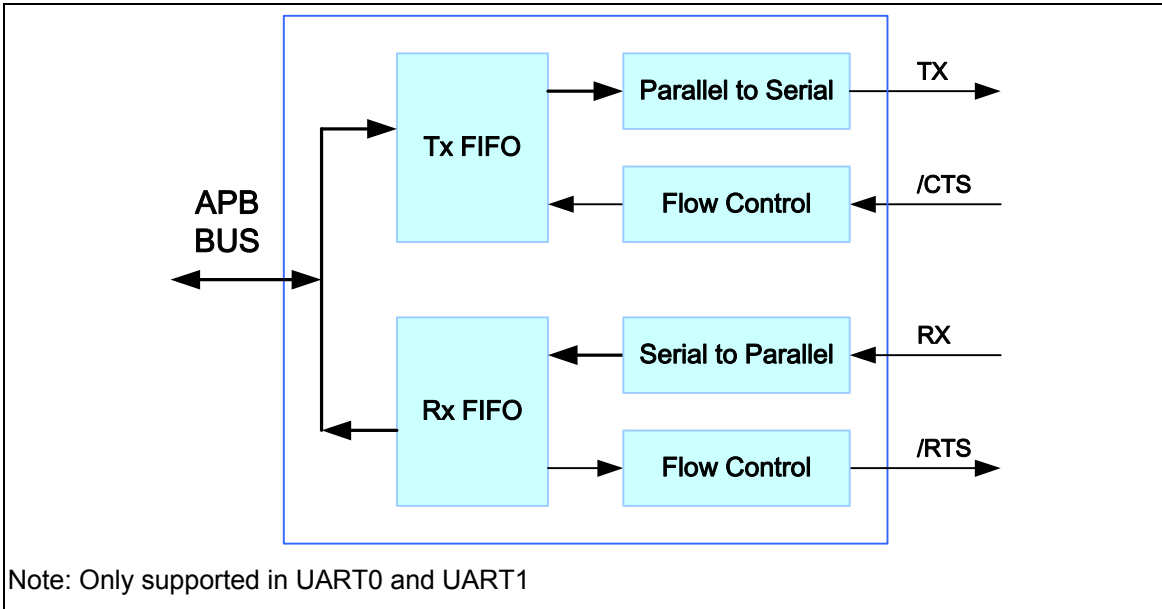

Figure 5-71 Auto Flow Control Block Diagram

### 5.12.4 IrDA Mode

The UART supports IrDA SIR (Serial Infrared) Transmit Encoder and Receive Decoder, and IrDA mode is selected by setting the **IrDA\_EN** bit in **UA\_FUN\_SEL** register.

When in IrDA mode, the UA\_BAUD [DIV\_X\_EN] register must disable.

**Baud Rate = Clock / (16 \* BRD)**, where BRD is Baud Rate Divider in UA\_BAUD register.

The following diagram demonstrates the IrDA control block diagram.

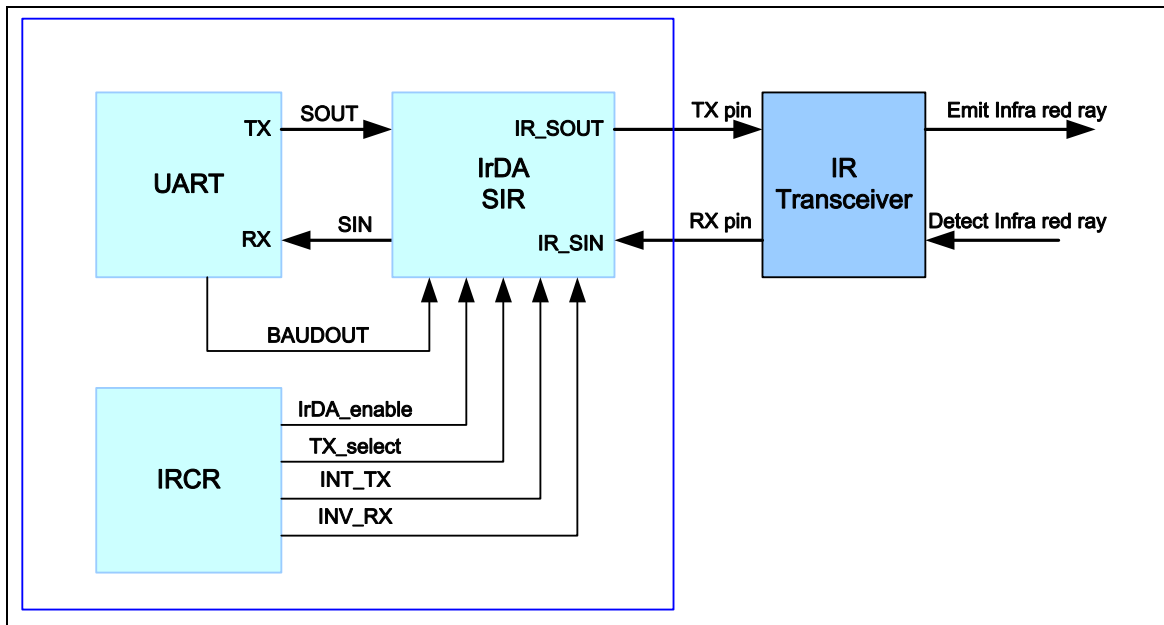

Figure 5-72 IrDA Block Diagram

#### 5.12.4.1 IrDA SIR Transmit Encoder

The IrDA SIR Transmit Encoder modulate Non-Return-to Zero (NRZ) transmit bit stream output from UART. The IrDA SIR physical layer specifies use of Return-to-Zero, Inverted (RZI) modulation scheme which represent logic 0 as an infra light pulse. The modulated output pulse stream is transmitted to an external output driver and infrared Light Emitting Diode.

In normal mode, the transmitted pulse width is specified as 3/16 period of baud rate.

#### 5.12.4.2 IrDA SIR Receive Decoder

The IrDA SIR Receive Decoder demodulates the return-to-zero bit stream from the input detector and outputs the NRZ serial bits stream to the UART received data input. The decoder input is normally high in the idle state. (Because of this, IRCR bit 6 should be set as 1 by default)

A start bit is detected when the decoder input is LOW

#### 5.12.4.3 IrDA SIR Operation

The IrDA SIR Encoder/decoder provides functionality which converts between UART data stream and half duplex serial SIR interface. The following diagram is IrDA encoder/decoder waveform:

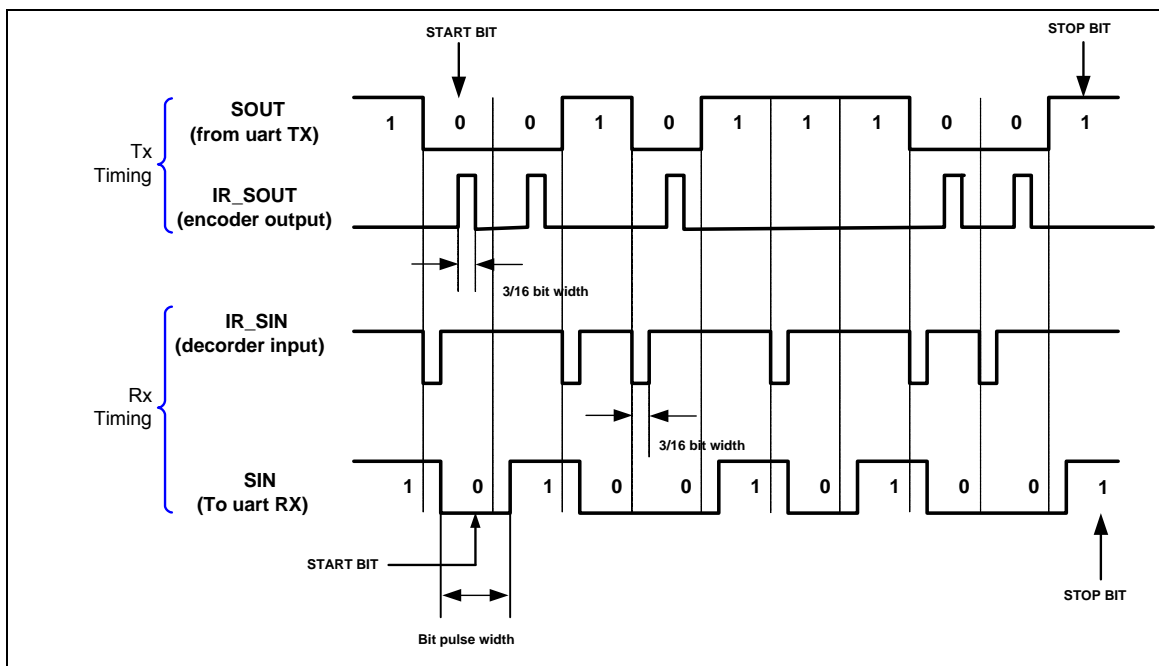

Figure 5-73 IrDA TX/RX Timing Diagram

### 5.12.5 RS-485 function mode (NuMicro™ NUC100/NUC120 Low Density Only)

The UART support **RS-485 9-bit mode function**. The RS-485 mode is selected by setting the UA\_FUN\_SEL register to select RS-485 function. The RS-485 driver control is implemented using the RTS control signal from an asynchronous serial port to enable the RS-485 driver. In RS-485 mode, many characteristics of the RX and TX are same as UART.

When in RS-485 mode, the controller can configuration of it as an RS-485 addressable slave and the RS-485 master transmitter will identify an address character by setting the parity (9<sup>th</sup> bit) to 1. For data characters, the parity is set to 0. Software can use UA\_LCR register to control the 9-th bit (When the PBE, EPE and SPE are set, the 9-th bit is transmitted 0 and when PBE and SPE are set and EPE is cleared, the 9-th bit is transmitted 1). The Controller support three operation mode that is RS-485 Normal Multidrop Operation Mode (NMM), RS-485 Auto Address Detection Operation Mode (AAD) and RS-485 Auto Direction Control Operation Mode (AUD), software can choose any operation mode by programming UA\_RS-485\_CSR register, and software can driving the transfer delay time between the last stop bit leaving the TX-FIFO and the de-assertion of by setting UA\_TOR [DLY] register.

#### RS-485 Normal Multidrop Operation Mode (NMM)

In RS-485 Normal Multidrop operation mode, in first, software must decided the data which before the address byte be detected will be stored in RX-FIFO or not. If software want to ignore any data before address byte detected, the flow is set UART\_FCR[RS485\_RX\_DIS] then enable UA\_RS-485[RS485\_NMM] and the receiver will ignore any data until an address byte is detected (bit9 =1) and the address byte data will be stored in the RX-FIFO. If software wants to receive any data before address byte detected, the flow is disable UART\_FCR [RS485\_RX\_DIS] then enable UA\_RS-485[RS485\_NMM] and the receiver will received any data. If an address byte is detected (bit9 =1), it will generator an interrupt to CPU and software can decide whether enable or disable receiver to accept the following data byte by setting UA\_RS-485\_CSR [RX\_DIS]. If the receiver is be enabled, all received byte data will be accepted and stored in the RX-FIFO, and if the receiver is disabled, all received byte data will be ignore until the next address byte be detected. If software disable receiver by setting UA\_RS-485\_CSR [RX\_DIS] register, when a next address byte be detected, the controller will clear the UA\_RS-485\_CSR [RX\_DIS] bit and the address byte data will be stored in the RX-FIFO.

#### RS-485 Auto Address Detection Operation Mode (AAD)

In RS-485 Auto Address Detection Operation Mode, the receiver will ignore any data until an address byte is detected (bit9 =1) and the address byte data match the UA\_RS-485[ADDR\_MATCH] value. The address byte data will be stored in the RX-FIFO. The all received byte data will be accepted and stored in the RX-FIFO until and address byte data not match the UA\_RS-485[ADDR\_MATCH] value.

#### RS-485 Auto Direction Mode (AUD)

Another option function of RS-485 controllers is **RS-485 auto direction control function**. The RS-485 driver control is implemented using the RTS control signal from an asynchronous serial port to enable the RS-485 driver. The RTS line is connected to the RS-485 driver enable such that setting the RTS line to high (logic 1) enables the RS-485 driver. Setting the RTS line to low (logic 0) puts the driver into the tri-state condition. User can setting LEV\_RTS in UA\_MCR register to change the RTS driving level.

Program Sequence example:

1. Program FUN\_SEL in UA\_FUN\_SEL to select RS-485 function.
2. Program the RX\_DIS bit in UA\_FCR register to determine enable or disable RS-485 receiver
3. Program the RS-485\_NMM or RS-485\_AAD mode.
4. If the RS-485\_AAD mode is selected, the ADDR\_MATCH is programmed for auto address match value.
5. Determine auto direction control by programming RS-485\_AUD.

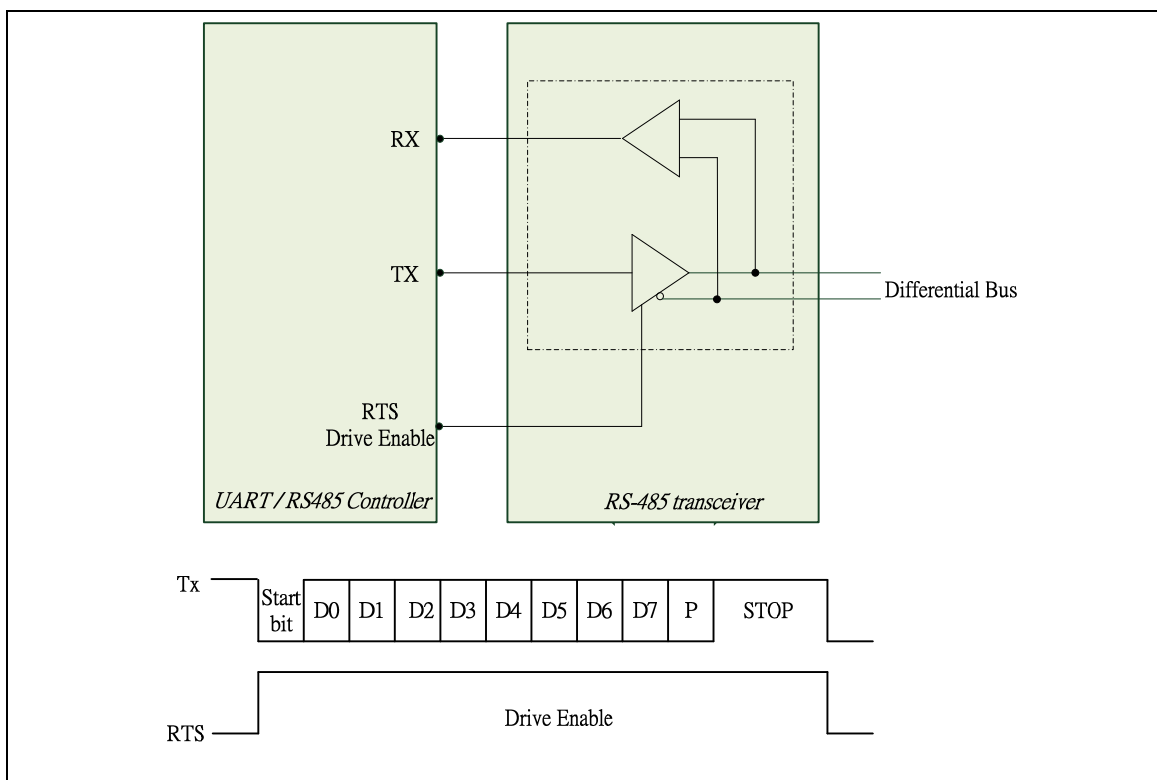

Figure 5-74 Structure of RS-485 Frame





## 5.12.6 Register Map

R: read only, W: write only, R/W: both read and write

Register	Offset	R/W	Description	Reset Value
<b>UART Base Address :</b>				
<b>Channel0 : UART0_BA (High Speed) = 0x4005_0000</b>				
<b>Channel1 : UART1_BA (Normal Speed)= 0x4015_0000</b>				
<b>Channel2 : UART2_BA (Normal Speed)= 0x4015_4000</b>				
<b>UA_RBR</b>	UART0_BA+0x00	R	UART0 Receive Buffer Register	Undefined
	UART1_BA+0x00	R	UART1 Receive Buffer Register	Undefined
	UART2_BA+0x00	R	UART2 Receive Buffer Register	Undefined
<b>UA_THR</b>	UART0_BA+0x00	W	UART0 Transmit Holding Register	Undefined
	UART1_BA+0x00	W	UART1 Transmit Holding Register	Undefined
	UART2_BA+0x00	W	UART2 Transmit Holding Register	Undefined
<b>UA_IER</b>	UART0_BA+0x04	R/W	UART0 Interrupt Enable Register	0x0000_0000
	UART1_BA+0x04	R/W	UART1 Interrupt Enable Register	0x0000_0000
	UART2_BA+0x04	R/W	UART2 Interrupt Enable Register	0x0000_0000
<b>UA_FCR</b>	UART0_BA+0x08	R/W	UART0 FIFO Control Register	0x0000_0000
	UART1_BA+0x08	R/W	UART1 FIFO Control Register	0x0000_0000
	UART2_BA+0x08	R/W	UART2 FIFO Control Register	0x0000_0000
<b>UA_LCR</b>	UART0_BA+0x0C	R/W	UART0 Line Control Register	0x0000_0000
	UART1_BA+0x0C	R/W	UART1 Line Control Register	0x0000_0000
	UART2_BA+0x0C	R/W	UART2 Line Control Register	0x0000_0000
<b>UA_MCR</b>	UART0_BA+0x10	R/W	UART0 Modem Control Register	0x0000_0200
	UART1_BA+0x10	R/W	UART1 Modem Control Register	0x0000_0200
	UART2_BA+0x10	R/W	Reserved	0x0000_0000
<b>UA_MSR</b>	UART0_BA+0x14	R/W	UART0 Modem Status Register	0x0000_0000
	UART1_BA+0x14	R/W	UART1 Modem Status Register	0x0000_0000
	UART2_BA+0x14	R/W	Reserved	0x0000_0000
<b>UA_FSR</b>	UART0_BA+0x18	R/W	UART0 FIFO Status Register	0x1040_4000
	UART1_BA+0x18	R/W	UART1 FIFO Status Register	0x1040_4000



Register	Offset	R/W	Description	Reset Value
	UART2_BA+0x18	R/W	UART2 FIFO Status Register	0x1040_4000
UA_ISR	UART0_BA+0x1C	R/W	UART0 Interrupt Status Register	0x0000_0002
	UART1_BA+0x1C	R/W	UART1 Interrupt Status Register	0x0000_0002
	UART2_BA+0x1C	R/W	UART2 Interrupt Status Register	0x0000_0002
UA_TOR	UART0_BA+0x20	R/W	UART0 Time Out Register	0x0000_0000
	UART1_BA+0x20	R/W	UART1 Time Out Register	0x0000_0000
	UART2_BA+0x20	R/W	UART2 Time Out Register	0x0000_0000
UA_BAUD	UART0_BA+0x24	R/W	UART0 Baud Rate Divisor Register	0x0F00_0000
	UART1_BA+0x24	R/W	UART1 Baud Rate Divisor Register	0x0F00_0000
	UART2_BA+0x24	R/W	UART2 Baud Rate Divisor Register	0x0F00_0000
UA_IRCR	UART0_BA+0x28	R/W	UART0 IrDA Control Register	0x0000_0040
	UART1_BA+0x28	R/W	UART1 IrDA Control Register	0x0000_0040
	UART2_BA+0x28	R/W	UART2 IrDA Control Register	0x0000_0040
UA_ALT_CSR	UART0_BA+0x2C	R/W	UART0 Alternate Control/Status Register	0x0000_0000
	UART1_BA+0x2C	R/W	UART1 Alternate Control/Status Register	0x0000_0000
	UART2_BA+0x2C	R/W	UART2 Alternate Control/Status Register	0x0000_0000
UA_FUN_SEL	UART0_BA+0x30	R/W	UART0 Function Select Register	0x0000_0000
	UART1_BA+0x30	R/W	UART1 Function Select Register	0x0000_0000
	UART2_BA+0x30	R/W	UART2 Function Select Register	0x0000_0000



5.12.7 Register Description

**Receive Buffer Register (UA\_RBR)**

Register	Offset	R/W	Description	Reset Value
UA_RBR	UART0_BA+0x00	R	UART0 Receive Buffer Register	Undefined
	UART1_BA+0x00	R	UART1 Receive Buffer Register	Undefined
	UART2_BA+0x00	R	UART2 Receive Buffer Register	Undefined

31	30	29	28	27	26	25	24
Reserved							
23	22	21	20	19	18	17	16
Reserved							
15	14	13	12	11	10	9	8
Reserved							
7	6	5	4	3	2	1	0
RBR							

Bits	Descriptions	
[31:8]	Reserved	Reserved
[7:0]	RBR	<b>Receive Buffer Register (Read Only)</b> By reading this register, the UART will return an 8-bit data received from RX pin (LSB first).



## Transmit Holding Register (UA\_THR)

Register	Offset	R/W	Description	Reset Value
UA_THR	UART0_BA+0x00	W	UART0 Transmit Holding Register	Undefined
	UART1_BA+0x00	W	UART1 Transmit Holding Register	Undefined
	UART2_BA+0x00	W	UART2 Transmit Holding Register	Undefined

31	30	29	28	27	26	25	24
Reserved							
23	22	21	20	19	18	17	16
Reserved							
15	14	13	12	11	10	9	8
Reserved							
7	6	5	4	3	2	1	0
THR							

Bits	Descriptions	
[31:8]	Reserved	Reserved
[7:0]	THR	<b>Transmit Holding Register</b> By writing to this register, the UART will send out an 8-bit data through the TX pin (LSB first).



**Interrupt Enable Register (UA\_IER)**

Register	Offset	R/W	Description	Reset Value
UA_IER	UART0_BA+0x04	R/W	UART0 Interrupt Enable Register	0x0000_0000
	UART1_BA+0x04	R/W	UART1 Interrupt Enable Register	0x0000_0000
	UART2_BA+0x04	R/W	UART2 Interrupt Enable Register	0x0000_0000

31	30	29	28	27	26	25	24	
Reserved								
23	22	21	20	19	18	17	16	
Reserved								
15	14	13	12	11	10	9	8	
DMA_RX_EN	DMA_TX_EN	AUTO_CTS_EN	AUTO_RTS_EN	TIME_OUT_EN	Reserved			8
7	6	5	4	3	2	1	0	
Reserved	WAKE_EN	BUF_ERR_EN	RTO_IEN	MODEM_IEN	RLS_IEN	THRE_IEN	RDA_IEN	

Bits	Descriptions	
[31:16]	Reserved	Reserved
[15]	DMA_RX_EN	<p><b>RX DMA Enable (not available in UART2 channel)</b></p> <p>This bit can enable or disable RX DMA service.</p> <p>1 = Enable RX DMA</p> <p>0 = Disable RX DMA</p>
[14]	DMA_TX_EN	<p><b>TX DMA Enable (not available in UART2 channel)</b></p> <p>This bit can enable or disable TX DMA service.</p> <p>1 = Enable TX DMA</p> <p>0 = Disable TX DMA</p>
[13]	AUTO_CTS_EN	<p><b>CTS Auto Flow Control Enable (not available in UART2 channel)</b></p> <p>1 = Enable CTS auto flow control</p> <p>0 = Disable CTS auto flow control</p> <p>When CTS auto-flow is enabled, the UART will send data to external device when CTS input assert (UART will not send data to device until CTS is asserted).</p>
[12]	AUTO_RTS_EN	<p><b>RTS Auto Flow Control Enable (not available in UART2 channel)</b></p> <p>1 = Enable RTS auto flow control</p> <p>0 = Disable RTS auto flow control</p> <p>When RTS auto-flow is enabled, if the number of bytes in the RX FIFO equals the UA_FCR [RTS_TRI_LEV], the UART will de-assert RTS signal.</p>



Bits	Descriptions	
[11]	<b>TIME_OUT_EN</b>	<b>Time Out Counter Enable</b> 1 = Enable Time-out counter 0 = Disable Time-out counter
[10:7]	<b>Reserved</b>	Reserved
[6]	<b>WAKE_EN</b>	<b>UART Wake-up Function Enable (not available in UART2 channel)</b> 0 = Disable UART wake-up function 1 = Enable UART wake-up function, when the chip is in power down mode, an external CTS change will wake-up chip from power down mode.
[5]	<b>BUF_ERR_IEN</b>	<b>Buffer Error Interrupt Enable</b> 1 = Enable INT_BUF_ERR 0 = Mask off INT_BUF_ERR
[4]	<b>RTO_IEN</b>	<b>RX Time Out Interrupt Enable</b> 1 = Enable INT_TOUT 0 = Mask off INT_TOUT
[3]	<b>MODEM_IEN</b>	<b>Modem Status Interrupt Enable (not available in UART2 channel)</b> 1 = Enable INT_MODEM 0 = Mask off INT_MODEM
[2]	<b>RLS_IEN</b>	<b>Receive Line Status Interrupt Enable</b> 1 = Enable INT_RLS 0 = Mask off INT_RLS
[1]	<b>THRE_IEN</b>	<b>Transmit Holding Register Empty Interrupt Enable</b> 1 = Enable INT_THRE 0 = Mask off INT_THRE
[0]	<b>RDA_IEN</b>	<b>Receive Data Available Interrupt Enable.</b> 1 = Enable INT_RDA 0 = Mask off INT_RDA



## FIFO Control Register (UA\_FCR)

Register	Offset	R/W	Description	Reset Value
UA_FCR	UART0_BA+0x08	R/W	UART0 FIFO Control Register	0x0000_0000
	UART1_BA+0x08	R/W	UART1 FIFO Control Register	0x0000_0000
	UART2_BA+0x08	R/W	UART2 FIFO Control Register	0x0000_0000

31	30	29	28	27	26	25	24
Reserved							
23	22	21	20	19	18	17	16
Reserved				RTS_TRI_LEV			
15	14	13	12	11	10	9	8
Reserved							RX_DIS
7	6	5	4	3	2	1	0
RFITL				Reserved	TFR	RFR	Reserved

Bits	Descriptions																			
[31:20]	Reserved	Reserved																		
[19:16]	RTS_TRI_LEV	<b>RTS Trigger Level for Auto-flow Control Use (not available in UART2 channel)</b>																		
		<table border="1" style="width: 100%;"> <thead> <tr> <th style="width: 30%;">RTS_TRI_LEV</th> <th>Trigger Level (Bytes)</th> </tr> </thead> <tbody> <tr> <td>0000</td> <td>01</td> </tr> <tr> <td>0001</td> <td>04</td> </tr> <tr> <td>0010</td> <td>08</td> </tr> <tr> <td>0011</td> <td>14</td> </tr> <tr> <td>0100</td> <td>30/14 (High Speed/Normal Speed)</td> </tr> <tr> <td>0101</td> <td>46/14 (High Speed/Normal Speed)</td> </tr> <tr> <td>0110</td> <td>62/14 (High Speed/Normal Speed)</td> </tr> <tr> <td>others</td> <td>62/14 (High Speed/Normal Speed)</td> </tr> </tbody> </table>	RTS_TRI_LEV	Trigger Level (Bytes)	0000	01	0001	04	0010	08	0011	14	0100	30/14 (High Speed/Normal Speed)	0101	46/14 (High Speed/Normal Speed)	0110	62/14 (High Speed/Normal Speed)	others	62/14 (High Speed/Normal Speed)
		RTS_TRI_LEV	Trigger Level (Bytes)																	
		0000	01																	
		0001	04																	
		0010	08																	
		0011	14																	
		0100	30/14 (High Speed/Normal Speed)																	
		0101	46/14 (High Speed/Normal Speed)																	
		0110	62/14 (High Speed/Normal Speed)																	
others	62/14 (High Speed/Normal Speed)																			
Note: This field is used for auto RTS flow control.																				
[15:9]	Reserved	Reserved																		
[8]	RX_DIS	<b>Receiver Disable register.</b>																		
		The receiver is disabled or not (set 1 is disable receiver) 1 = Disable Receiver 0 = Enable Receiver Note: This field is used for RS-485 Normal Multi-drop mode. It should be programmed																		



Bits	Descriptions																			
		before UA_ALT_CSR [RS-485_NMM] is programmed.																		
[7:4]	RFITL	<p><b>RX FIFO Interrupt (INT_RDA) Trigger Level</b></p> <p>When the number of bytes in the receive FIFO equals the RFITL then the RDA_IF will be set (if UA_IER [RDA_IEN] is enable, an interrupt will generated).</p> <table border="1" style="width: 100%; border-collapse: collapse;"> <thead> <tr> <th style="text-align: center;">RFITL</th> <th style="text-align: center;">INTR_RDA Trigger Level (Bytes)</th> </tr> </thead> <tbody> <tr> <td style="text-align: center;">0000</td> <td style="text-align: center;">01</td> </tr> <tr> <td style="text-align: center;">0001</td> <td style="text-align: center;">04</td> </tr> <tr> <td style="text-align: center;">0010</td> <td style="text-align: center;">08</td> </tr> <tr> <td style="text-align: center;">0011</td> <td style="text-align: center;">14</td> </tr> <tr> <td style="text-align: center;">0100</td> <td style="text-align: center;">30/14 (High Speed/Normal Speed)</td> </tr> <tr> <td style="text-align: center;">0101</td> <td style="text-align: center;">46/14 (High Speed/Normal Speed)</td> </tr> <tr> <td style="text-align: center;">0110</td> <td style="text-align: center;">62/14 (High Speed/Normal Speed)</td> </tr> <tr> <td style="text-align: center;">others</td> <td style="text-align: center;">62/14 (High Speed/Normal Speed)</td> </tr> </tbody> </table>	RFITL	INTR_RDA Trigger Level (Bytes)	0000	01	0001	04	0010	08	0011	14	0100	30/14 (High Speed/Normal Speed)	0101	46/14 (High Speed/Normal Speed)	0110	62/14 (High Speed/Normal Speed)	others	62/14 (High Speed/Normal Speed)
RFITL	INTR_RDA Trigger Level (Bytes)																			
0000	01																			
0001	04																			
0010	08																			
0011	14																			
0100	30/14 (High Speed/Normal Speed)																			
0101	46/14 (High Speed/Normal Speed)																			
0110	62/14 (High Speed/Normal Speed)																			
others	62/14 (High Speed/Normal Speed)																			
[3]	<b>Reserved</b>	Reserved																		
[2]	TFR	<p><b>TX Field Software Reset</b></p> <p>When TX_RST is set, all the byte in the transmit FIFO and TX internal state machine are cleared.</p> <p>1 = Writing 1 to this bit will reset the TX internal state machine and pointers.</p> <p>0 = Writing 0 to this bit has no effect.</p> <p>Note: This bit will auto clear needs at least 3 UART engine clock cycles.</p>																		
[1]	RFR	<p><b>RX Field Software Reset</b></p> <p>When RX_RST is set, all the byte in the receiver FIFO and RX internal state machine are cleared.</p> <p>1 = Writing 1 to this bit will reset the RX internal state machine and pointers.</p> <p>0 = Writing 0 to this bit has no effect.</p> <p>Note: This bit will auto clear needs at least 3 UART engine clock cycles.</p>																		
[0]	<b>Reserved</b>	Reserved																		





## Line Control Register (UA\_LCR)

Register	Offset	R/W	Description	Reset Value
UA_LCR	UART0_BA+0x0C	R/W	UART0 Line Control Register	0x0000_0000
	UART1_BA+0x0C	R/W	UART1 Line Control Register	0x0000_0000
	UART2_BA+0x0C	R/W	UART2 Line Control Register	0x0000_0000

31	30	29	28	27	26	25	24
Reserved							
23	22	21	20	19	18	17	16
Reserved							
15	14	13	12	11	10	9	8
Reserved							
7	6	5	4	3	2	1	0
Reserved	BCB	SPE	EPE	PBE	NSB	WLS	

Bits	Descriptions	
[31:7]	Reserved	Reserved
[6]	BCB	<b>Break Control Bit</b> When this bit is set to logic 1, the serial data output (TX) is forced to the Spacing State (logic 0). This bit acts only on TX and has no effect on the transmitter logic.
[5]	SPE	<b>Stick Parity Enable</b> 1 = If bit 3 and 4 are logic 1, the parity bit is transmitted and checked as logic 0. If bit 3 is 1 and bit 4 is 0 then the parity bit is transmitted and checked as 1 0 = Stick parity disabled
[4]	EPE	<b>Even Parity Enable</b> 1 = Even number of logic 1's is transmitted and checked in each word 0 = Odd number of logic 1's is transmitted and checked in each word This bit has effect only when bit 3 (parity bit enable) is set.
[3]	PBE	<b>Parity Bit Enable</b> 1 = Parity bit is generated on each outgoing character and is checked on each incoming data. 0 = No parity bit.
[2]	NSB	<b>Number of "STOP bit"</b> 1 = 2 STOP bits (1.5 STOP bits if WLS[1:0]=00) 0 = 1 STOP bit.
[1:0]	WLS	<b>Word Length Select</b>



Bits	Descriptions		
		WLS[1:0]	Character length
		00	5-bit
		01	6-bit
		10	7-bit
		11	8-bit



## MODEM Control Register (UA\_MCR) (not available in UART2 channel)

Register	Offset	R/W	Description	Reset Value
UA_MCR	UART0_BA+0x10	R/W	UART0 Modem Control Register	0x0000_0200
	UART1_BA+0x10	R/W	UART1 Modem Control Register	0x0000_0200
	UART2_BA+0x10	R/W	Reserved	0x0000_0000

31	30	29	28	27	26	25	24
Reserved							
23	22	21	20	19	18	17	16
Reserved							
15	14	13	12	11	10	9	8
Reserved		RTS_ST	Reserved			LEV_RTS	Reserved
7	6	5	4	3	2	1	0
Reserved						RTS	Reserved

Bits	Descriptions	
[31:14]	Reserved	Reserved
[13]	RTS_ST	RTS Pin State (Read Only) (not available in UART2 channel) This bit is the output pin status of RTS.
[12:10]	Reserved	Reserved



Bits	Descriptions	
[9]	<b>LEV_RTS</b>	<p><b>RTS Trigger Level (not available in UART2 channel)</b></p> <p>This bit can change the RTS trigger level.</p> <p>1= high level triggered 0= low level triggered</p> <p><i>UART Mode : MCR[LEV_RTS]=1</i></p> <p><i>UART Mode : MCR[LEV_RTS]=0</i></p> <p><i>RS-485 Mode : MCR[LEV_RTS]=1</i></p> <p><i>RS-485 Mode : MCR[LEV_RTS]=0</i></p>
[8:2]	<b>Reserved</b>	Reserved
[1]	<b>RTS</b>	<p><b>RTS (Request-To-Send) Signal (not available in UART2 channel)</b></p> <p>0 = Drive RTS pin to logic 1 (If the <b>LEV_RTS</b> set to low level triggered). 1 = Drive RTS pin to logic 0 (If the <b>LEV_RTS</b> set to low level triggered). 0 = Drive RTS pin to logic 0 (If the <b>LEV_RTS</b> set to high level triggered). 1 = Drive RTS pin to logic 1 (If the <b>LEV_RTS</b> set to high level triggered).</p>
[0]	<b>Reserved</b>	Reserved



**Modem Status Register (UA\_MSR) (not available in UART2 channel)**

Register	Offset	R/W	Description	Reset Value
UA_MSR	UART0_BA+0x14	R/W	UART0 Modem Status Register	0x0000_0000
	UART1_BA+0x14	R/W	UART1 Modem Status Register	0x0000_0000
	UART2_BA+0x14	R/W	Reserved	0x0000_0000

31	30	29	28	27	26	25	24
Reserved							
23	22	21	20	19	18	17	16
Reserved							
15	14	13	12	11	10	9	8
Reserved							LEV_CTS
7	6	5	4	3	2	1	0
Reserved			CTS_ST	Reserved			DCTS_F

Bits	Descriptions	
[31:9]	Reserved	Reserved
[8]	LEV_CTS	<b>CTS Trigger Level (not available in UART2 channel)</b> This bit can change the CTS trigger level. 1= high level triggered 0= low level triggered
[7:5]	Reserved	Reserved
[4]	CTS_ST	<b>CTS Pin Status (Read Only) (not available in UART2 channel)</b> This bit is the pin status of CTS.
[3:1]	Reserved	Reserved
[0]	DCTS_F	<b>Detect CTS State Change Flag (Read Only) (not available in UART2 channel)</b> This bit is set whenever CTS input has change state, and it will generate Modem interrupt to CPU when UA_IER [MODEM_IEN] is set to 1. Software can write 1 to clear this bit to zero



## FIFO Status Register (UA\_FSR)

Register	Offset	R/W	Description	Reset Value
UA_FSR	UART0_BA+0x18	R/W	UART0 FIFO Status Register	0x1040_4000
	UART1_BA+0x18	R/W	UART1 FIFO Status Register	0x1040_4000
	UART2_BA+0x18	R/W	UART2 FIFO Status Register	0x1040_4000

31	30	29	28	27	26	25	24
Reserved			TE_FLAG	Reserved			TX_OVER_IF
23	22	21	20	19	18	17	16
Reserved	TX_EMPTY	TX_POINTER					
15	14	13	12	11	10	9	8
Reserved	RX_EMPTY	RX_POINTER					
7	6	5	4	3	2	1	0
Reserved	BIF	FEF	PEF	RS485_ADD_DETF	Reserved		RX_OVER_IF

Bits	Descriptions	
[31:29]	Reserved	Reserved
[28]	TE_FLAG	<p><b>Transmitter Empty Flag (Read Only)</b></p> <p>Bit is set by hardware when TX FIFO (UA_THR) is empty and the STOP bit of the last byte has been transmitted.</p> <p>Bit is cleared automatically when TX FIFO is not empty or the last byte transmission has not completed.</p>
[27:25]	Reserved	Reserved
[24]	TX_OVER_IF	<p><b>TX Overflow Error Interrupt Flag (Read Only)</b></p> <p>If TX FIFO (UA_THR) is full, an additional write to UA_THR will cause this bit to logic 1.</p> <p>Note: This bit is read only, but can be cleared by writing '1' to it.</p>
[23]	Reserved	Reserved
[22]	TX_EMPTY	<p><b>Transmitter FIFO Empty (Read Only)</b></p> <p>This bit indicates TX FIFO empty or not.</p> <p>When the last byte of TX FIFO has been transferred to Transmitter Shift Register, hardware sets this bit high. It will be cleared when writing data into THR (TX FIFO not empty).</p>
[21:16]	TX_POINTER	<p><b>TX FIFO Pointer (Read Only)</b></p> <p>This field indicates the TX FIFO Buffer Pointer. When CPU writes one byte into UA_THR, TX_POINTER increases one. When one byte of TX FIFO is transferred to Transmitter Shift Register, TX_POINTER decreases one.</p>



Bits	Descriptions	
[15]	<b>Reserved</b>	Reserved
[14]	<b>RX_EMPTY</b>	<p><b>Receiver FIFO Empty (Read Only)</b></p> <p>This bit initiate RX FIFO empty or not.</p> <p>When the last byte of RX FIFO has been read by CPU, hardware sets this bit high. It will be cleared when UART receives any new data.</p>
[13:8]	<b>RX_POINTER</b>	<p><b>RX FIFO Pointer (Read Only)</b></p> <p>This field indicates the RX FIFO Buffer Pointer. When UART receives one byte from external device, RX_POINTER increases one. When one byte of RX FIFO is read by CPU, RX_POINTER decreases one.</p>
[7]	<b>Reserved</b>	Reserved
[6]	<b>BIF</b>	<p><b>Break Interrupt Flag (Read Only)</b></p> <p>This bit is set to a logic 1 whenever the received data input(RX) is held in the "spacing state" (logic 0) for longer than a full word transmission time (that is, the total time of "start bit" + data bits + parity + stop bits) and is reset whenever the CPU writes 1 to this bit.</p> <p>Note: This bit is read only, but can be cleared by writing '1' to it.</p>
[5]	<b>FEF</b>	<p><b>Framing Error Flag (Read Only)</b></p> <p>This bit is set to logic 1 whenever the received character does not have a valid "stop bit" (that is, the stop bit following the last data bit or parity bit is detected as a logic 0), and is reset whenever the CPU writes 1 to this bit.</p> <p>Note: This bit is read only, but can be cleared by writing '1' to it.</p>
[4]	<b>PEF</b>	<p><b>Parity Error Flag (Read Only)</b></p> <p>This bit is set to logic 1 whenever the received character does not have a valid "parity bit", and is reset whenever the CPU writes 1 to this bit.</p> <p>Note: This bit is read only, but can be cleared by writing '1' to it.</p>
[3]	<b>RS485_ADD_DETF</b>	<p><b>RS-485 Address Byte Detection Flag (NuMicro™ NUC100/NUC120Low Density Only)</b></p> <p>This bit is set to logic 1 and set UA_ALT_CSR [RS-485_ADD_EN] whenever in RS-485 mode the receiver detect any address byte received address byte character (bit9 = '1') bit", and it is reset whenever the CPU writes 1 to this bit.</p> <p>Note: This field is used for RS-485 function mode.</p> <p>Note: This bit is read only, but can be cleared by writing '1' to it.</p>
[2:1]	<b>Reserved</b>	Reserved
[0]	<b>RX_OVER_IF</b>	<p><b>RX Overflow Error IF (Read Only)</b></p> <p>This bit is set when RX FIFO overflow.</p> <p>If the number of bytes of received data is greater than RX_FIFO (UA_RBR) size, 64/16 bytes of UART0/UART1, this bit will be set.</p> <p>Note: This bit is read only, but can be cleared by writing '1' to it.</p>



**Interrupt Status Control Register (UA\_ISR)**

Register	Offset	R/W	Description	Reset Value
UA_ISR	UART0_BA+0x1C	R/W	UART0 Interrupt Status Register	0x0000_0002
	UART1_BA+0x1C	R/W	UART1 Interrupt Status Register	0x0000_0002
	UART2_BA+0x1C	R/W	UART2 Interrupt Status Register	0x0000_0002

31	30	29	28	27	26	25	24
Reserved		HW_BUF_ERR_INT	HW_TOUT_INT	HW_MODEM_INT	HW_RLS_INT	Reserved	
23	22	21	20	19	18	17	16
Reserved		HW_BUF_ERR_IF	HW_TOUT_IF	HW_MODEM_IF	HW_RLS_IF	Reserved	
15	14	13	12	11	10	9	8
Reserved		BUF_ERR_INT	TOUT_INT	MODEM_INT	RLS_INT	THRE_INT	RDA_INT
7	6	5	4	3	2	1	0
Reserved		BUF_ERR_IF	TOUT_IF	MODEM_IF	RLS_IF	THRE_IF	RDA_IF

Bits	Descriptions	
[31:30]	Reserved	Reserved
[29]	HW_BUF_ERR_INT	<b>In DMA Mode, Buffer Error Interrupt Indicator (Read Only)</b> This bit is set if BUF_ERR_IEN and HW_BUF_ERR_IF are both set to 1. 1 = The buffer error interrupt is generated in DMA mode 0 = No buffer error interrupt is generated in DMA mode
[28]	HW_TOUT_INT	<b>In DMA Mode, Time Out Interrupt Indicator (Read Only)</b> This bit is set if TOUT_IEN and HW_TOUT_IF are both set to 1. 1 = The Tout interrupt is generated in DMA mode 0 = No Tout interrupt is generated in DMA mode
[27]	HW_MODEM_INT	<b>In DMA Mode, MODEM Status Interrupt Indicator (Read Only) (not available in UART2 channel)</b> This bit is set if MODEM_IEN and HW_MODEM_IF are both set to 1. 1 = The Modem interrupt is generated in DMA mode 0 = No Modem interrupt is generated in DMA mode
[26]	HW_RLS_INT	<b>In DMA Mode, Receive Line Status Interrupt Indicator (Read Only)</b> This bit is set if RLS_IEN and HW_RLS_IF are both set to 1. 1 = The RLS interrupt is generated in DMA mode 0 = No RLS interrupt is generated in DMA mode





Bits	Descriptions	
[25:22]	<b>Reserved</b>	Reserved
[21]	<b>HW_BUF_ERR_IF</b>	<p><b>In DMA Mode, Buffer Error Interrupt Flag (Read Only)</b></p> <p>This bit is set when the TX or RX FIFO overflows (TX_OVER_IF or RX_OVER_IF is set). When BUF_ERR_IF is set, the transfer maybe is not correct. If UA_IER [BUF_ERR_IEN] is enabled, the buffer error interrupt will be generated.</p> <p>Note: This bit is cleared when both TX_OVER_IF and RX_OVER_IF are cleared.</p>
[20]	<b>HW_TOUT_IF</b>	<p><b>In DMA Mode, Time Out Interrupt Flag (Read Only)</b></p> <p>This bit is set when the RX FIFO is not empty and no activities occurred in the RX FIFO and the time out counter equal to TOIC. If UA_IER [TOUT_IEN] is enabled, the Tout interrupt will be generated.</p> <p>Note: This bit is read only and user can read UA_RBR (RX is in active) to clear it.</p>
[19]	<b>HW_MODEM_IF</b>	<p><b>In DMA Mode, MODEM Interrupt Flag (Read Only) (not available in UART2 channel)</b></p> <p>This bit is set when the CTS pin has state change (DCTS=1). If UA_IER [MODEM_IEN] is enabled, the Modem interrupt will be generated.</p> <p>Note: This bit is read only and reset to 0 when bit DCTS is cleared by a write 1 on DCTS.</p>
[18]	<b>HW_RLS_IF</b>	<p><b>In DMA Mode, Receive Line Status Flag (Read Only)</b></p> <p>This bit is set when the RX receive data have parity error, framing error or break error (at least one of 3 bits, BIF, FEF and PEF, is set). If UA_IER [RLS_IEN] is enabled, the RLS interrupt will be generated.</p> <p>Note: When in RS-485 function mode, this field include "receiver detect any address byte received address byte character (bit9 = '1') bit".</p> <p>Note: This bit is read only and reset to 0 when all bits of BIF, FEF and PEF are cleared.</p>
[17:14]	<b>Reserved</b>	Reserved
[13]	<b>BUF_ERR_INT</b>	<p><b>Buffer Error Interrupt Indicator (Read Only)</b></p> <p>This bit is set if BUF_ERR_IEN and BUF_ERR_IF are both set to 1.</p> <p>1 = The buffer error interrupt is generated 0 = No buffer error interrupt is generated</p>
[12]	<b>TOUT_INT</b>	<p><b>Time Out Interrupt Indicator (Read Only)</b></p> <p>This bit is set if TOUT_IEN and TOUT_IF are both set to 1.</p> <p>1 = The Tout interrupt is generated 0 = No Tout interrupt is generated</p>
[11]	<b>MODEM_INT</b>	<p><b>MODEM Status Interrupt Indicator (Read Only). (not available in UART2 channel)</b></p> <p>This bit is set if MODEM_IEN and MODEM_IF are both set to 1.</p> <p>1 = The Modem interrupt is generated 0 = No Modem interrupt is generated</p>
[10]	<b>RLS_INT</b>	<p><b>Receive Line Status Interrupt Indicator (Read Only).</b></p> <p>This bit is set if RLS_IEN and RLS_IF are both set to 1.</p> <p>1 = The RLS interrupt is generated 0 = No RLS interrupt is generated</p>



Bits	Descriptions	
[9]	<b>THRE_INT</b>	<p><b>Transmit Holding Register Empty Interrupt Indicator (Read Only).</b></p> <p>This bit is set if THRE_IEN and THRE_IF are both set to 1.</p> <p>1 = The THRE interrupt is generated</p> <p>0 = No THRE interrupt is generated</p>
[8]	<b>RDA_INT</b>	<p><b>Receive Data Available Interrupt Indicator (Read Only).</b></p> <p>This bit is set if RDA_IEN and RDA_IF are both set to 1.</p> <p>1 = The RDA interrupt is generated</p> <p>0 = No RDA interrupt is generated</p>
[7:6]	<b>Reserved</b>	Reserved
[5]	<b>BUF_ERR_IF</b>	<p><b>Buffer Error Interrupt Flag (Read Only)</b></p> <p>This bit is set when the TX or RX FIFO overflows or Break Interrupt Flag or Parity Error Flag or Frame Error Flag (TX_OVER_IF or RX_OVER_IF or BIF or PEF or FEF) is set. When BUF_ERR_IF is set, the transfer is not correct. If UA_IER [BUF_ERR_IEN] is enabled, the buffer error interrupt will be generated.</p>
[4]	<b>TOUT_IF</b>	<p><b>Time Out Interrupt Flag (Read Only)</b></p> <p>This bit is set when the RX FIFO is not empty and no activities occurred in the RX FIFO and the time out counter equal to TOIC. If UA_IER [TOUT_IEN] is enabled, the Tout interrupt will be generated.</p> <p>Note: This bit is read only and user can read UA_RBR (RX is in active) to clear it.</p>
[3]	<b>MODEM_IF</b>	<p><b>MODEM Interrupt Flag (Read Only) (not available in UART2 channel)</b></p> <p>This bit is set when the CTS pin has state change (DCTS=1). If UA_IER [MODEM_IEN] is enabled, the Modem interrupt will be generated.</p> <p>Note: This bit is read only and reset to 0 when bit DCTS is cleared by a write 1 on DCTS.</p>
[2]	<b>RLS_IF</b>	<p><b>Receive Line Interrupt Flag (Read Only).</b></p> <p>This bit is set when the RX receive data have parity error, framing error or break error (at least one of 3 bits, BIF, FEF and PEF, is set). If UA_IER [RLS_IEN] is enabled, the RLS interrupt will be generated.</p> <p>Note: When in RS-485 function mode, this field include "receiver detect any address byte received address byte character (bit9 = '1') bit".</p> <p>Note: This bit is read only and reset to 0 when all bits of BIF, FEF and PEF are cleared.</p>
[1]	<b>THRE_IF</b>	<p><b>Transmit Holding Register Empty Interrupt Flag (Read Only).</b></p> <p>This bit is set when the last data of TX FIFO is transferred to Transmitter Shift Register. If UA_IER [THRE_IEN] is enabled, the THRE interrupt will be generated.</p> <p>Note: This bit is read only and it will be cleared when writing data into THR (TX FIFO not empty).</p>
[0]	<b>RDA_IF</b>	<p><b>Receive Data Available Interrupt Flag (Read Only).</b></p> <p>When the number of bytes in the RX FIFO equals the RFITL then the RDA_IF will be set. If UA_IER [RDA_IEN] is enabled, the RDA interrupt will be generated.</p> <p>Note: This bit is read only and it will be cleared when the number of unread bytes of RX FIFO drops below the threshold level (RFITL).</p>



UART Interrupt Source	Interrupt Enable Bit	Interrupt Indicator to Interrupt Controller	Interrupt Flag	Flag Cleared by
Buffer Error Interrupt INT_BUF_ERR	BUF_ERR_IEN	HW_BUF_ERR_INT	<b>HW_BUF_ERR_IF</b> = (TX_OVER_IF or RX_OVER_IF or BIF or PEF or FEF)	Writing '1' to UA_FCR [RFR]
RX Timeout Interrupt INT_TOUT	RTO_IEN	HW_TOUT_INT	<b>HW_TOUT_IF</b>	Read UA_RBR
Modem Status Interrupt INT_MODEM	MODEM_IEN	HW_MODEM_INT	<b>HW_MODEM_IF</b> = (DCTSIF)	Write '1' to DCTSIF
Receive Line Status Interrupt INT_RLS	RLS_IEN	HW_RLS_INT	<b>HW_RLS_IF</b> = (BIF or FEF or PEF or RS- 485_ADD_DETF)	Writing '1' to UA_FCR [RFR]
Transmit Holding Register Empty Interrupt INT_THRE	THRE_IEN	HW_THRE_INT	<b>HW_THRE_IF</b>	Write UA_THR
Receive Data Available Interrupt INT_RDA	RDA_IEN	HW_RDA_INT	<b>HW_RDA_IF</b>	Read UA_RBR

Table 5-11 UART Interrupt Sources and Flags Table In DMA Mode

UART Interrupt Source	Interrupt Enable Bit	Interrupt Indicator to Interrupt Controller	Interrupt Flag	Flag Cleared by
Buffer Error Interrupt INT_BUF_ERR	BUF_ERR_IEN	BUF_ERR_INT	<b>BUF_ERR_IF</b> = (TX_OVER_IF or RX_OVER_IF or BIF or PEF or FEF)	<b>Writing '1' to</b> UA_FCR [RFR]
RX Timeout Interrupt INT_TOUT	RTO_IEN	TOUT_INT	<b>TOUT_IF</b>	Read UA_RBR
Modem Status Interrupt INT_MODEM	MODEM_IEN	MODEM_INT	<b>MODEM_IF</b> = (DCTSIF)	Write '1' to DCTSIF
Receive Line Status Interrupt INT_RLS	RLS_IEN	RLS_INT	<b>RLS_IF</b> = (BIF or FEF or PEF or RS- 485_ADD_DETF)	<b>Writing '1' to</b> UA_FCR [RFR]
Transmit Holding Register Empty Interrupt INT_THRE	THRE_IEN	THRE_INT	<b>THRE_IF</b>	Write UA_THR
Receive Data Available Interrupt INT_RDA	RDA_IEN	RDA_INT	<b>RDA_IF</b>	Read UA_RBR

Table 5-12 UART Interrupt Sources and Flags Table In Software Mode



## Time out Register (UA TOR)

Register	Offset	R/W	Description	Reset Value
UA_TOR	UART0_BA+0x20	R/W	UART0 Time Out Register	0x0000_0000
	UART1_BA+0x20	R/W	UART1 Time Out Register	0x0000_0000
	UART2_BA+0x20	R/W	UART2 Time Out Register	0x0000_0000

31	30	29	28	27	26	25	24
Reserved							
23	22	21	20	19	18	17	16
Reserved							
15	14	13	12	11	10	9	8
DLY							
7	6	5	4	3	2	1	0
TOIC							

Bits	Descriptions	
[31:16]	Reserved	Reserved
[15:8]	DLY	<p><b>TX Delay time value</b> (NuMicro™ NUC100/NUC120 Low Density Only)</p> <p>This field is use to programming the transfer delay time between the last stop bit and next start bit.</p> <p>The diagram shows a TX signal line. It starts with a 'Start' pulse, followed by a rectangular pulse labeled 'Byte (i)'. After 'Byte (i)', there is a 'Stop' period. A dashed double-headed arrow labeled 'DLY' indicates the time interval between the end of the 'Stop' period and the beginning of the 'Start' pulse for 'Byte (i+1)'.</p>
[7:0]	TOIC	<p><b>Time Out Interrupt Comparator</b></p> <p>The time out counter resets and starts counting (the counting clock = baud rate) whenever the RX FIFO receives a new data word. Once the content of time out counter (TOUT_CNT) is equal to that of time out interrupt comparator (TOIC), a receiver time out interrupt (INT_TOUT) is generated if UA_IER [RTO_IEN]. A new incoming data word or RX FIFO empty clears INT_TOUT. In order to avoid receiver time out interrupt generation immediately during one character is being received, TOIC value should be set between 40 and 255. So, for example, if TOIC is set with 40, the time out interrupt is generated after four characters are not received when 1 stop bit and no parity check is set for UART transfer.</p>



## Baud Rate Divider Register (UA\_BAUD)

Register	Offset	R/W	Description	Reset Value
UA_BAUD	UART0_BA+0x24	R/W	UART0 Baud Rate Divisor Register	0x0F00_0000
	UART1_BA+0x24	R/W	UART1 Baud Rate Divisor Register	0x0F00_0000
	UART2_BA+0x24	R/W	UART2 Baud Rate Divisor Register	0x0F00_0000

31	30	29	28	27	26	25	24
Reserved		DIV_X_EN	DIV_X_ONE	DIVIDER_X			
23	22	21	20	19	18	17	16
Reserved							
15	14	13	12	11	10	9	8
BRD							
7	6	5	4	3	2	1	0
BRD							

Bits	Descriptions	
[31:30]	Reserved	Reserved
[29]	DIV_X_EN	<p><b>Divider X Enable</b></p> <p>The BRD = Baud Rate Divider, and the baud rate equation is                      Baud Rate = Clock / [M * (BRD + 2)]; The default value of M is 16.</p> <p>1 = Enable divider X (the equation of M = X+1, but DIVIDER_X [27:24] must &gt;= 8).                      0 = Disable divider X (the equation of M = 16)</p> <p>Refer to the table below for more information.</p> <p>Note: When in IrDA mode, this bit must disable.</p>
[28]	DIV_X_ONE	<p><b>Divider X equal 1</b></p> <p>1 = Divider M = 1 (the equation of M = 1, but BRD [15:0] must &gt;= 3).                      0 = Divider M = X (the equation of M = X+1, but DIVIDER_X[27:24] must &gt;= 8)</p> <p>Refer to the Table 5-13 below for more information.</p>
[27:24]	DIVIDER_X	<p><b>Divider X</b></p> <p>The baud rate divider M = X+1.</p>
[23:16]	Reserved	Reserved
[15:0]	BRD	<p><b>Baud Rate Divider</b></p> <p>The field indicated the baud rate divider</p>



Mode	DIV_X_EN	DIV_X_ONE	DIVIDER X	BRD	Baud rate equation
0	Disable	0	B	A	$UART\_CLK / [16 * (A+2)]$
1	Enable	0	B	A	$UART\_CLK / [(B+1) * (A+2)]$ , B must $\geq 8$
2	Enable	1	Don't care	A	$UART\_CLK / (A+2)$ , A must $\geq 3$

Table 5-13 Baud rate equation table



## IrDA Control Register (IRCR)

Register	Offset	R/W	Description	Reset Value
UA_IRCR	UART0_BA+0x28	R/W	UART0 IrDA Control Register	0x0000_0040
	UART1_BA+0x28	R/W	UART1 IrDA Control Register	0x0000_0040
	UART2_BA+0x28	R/W	UART2 IrDA Control Register	0x0000_0040

31	30	29	28	27	26	25	24
Reserved							
23	22	21	20	19	18	17	16
Reserved							
15	14	13	12	11	10	9	8
Reserved							
7	6	5	4	3	2	1	0
Reserved	INV_RX	INV_TX	Reserved			TX_SELECT	Reserved

Bits	Descriptions	
[31:7]	Reserved	Reserved
[6]	INV_RX	INV_RX 1= Inverse RX input signal 0= No inversion
[5]	INV_TX	INV_TX 1= Inverse TX output signal 0= No inversion
[4:2]	Reserved	Reserved
[1]	TX_SELECT	TX_SELECT 1= Enable IrDA transmitter 0= Enable IrDA receiver
[0]	Reserved	Reserved

Note: When in IrDA mode, the UA\_BAUD [DIV\_X\_EN] register must disable (the baud equation must be Clock / 16 \* (BRD))



## UART Alternate Control/Status Register (UA\_ALT\_CSR)

Register	Offset	R/W	Description	Reset Value
UA_ALT_CSR	UART0_BA+0x2C	R/W	UART0 Alternate Control/Status Register	0x0000_0000
	UART1_BA+0x2C	R/W	UART1 Alternate Control/Status Register	0x0000_0000
	UART2_BA+0x2C	R/W	UART2 Alternate Control/Status Register	0x0000_0000

31	30	29	28	27	26	25	24
<b>ADDR_MATCH</b>							
23	22	21	20	19	18	17	16
<b>Reserved</b>							
15	14	13	12	11	10	9	8
RS485_ADD_EN	<b>Reserved</b>				RS485_AUD	RS485_AAD	RS485_NMM
7	6	5	4	3	2	1	0
<b>Reserved</b>							

Bits	Descriptions	
[31:24]	<b>ADDR_MATCH</b>	<b>Address match value register</b> (NuMicro™ NUC100/NUC120 Low Density Only) This field contains the RS-485 address match values. Note: This field is used for RS-485 auto address detection mode.
[23:16]	<b>Reserved</b>	Reserved
[15]	<b>RS485_ADD_EN</b>	<b>RS-485 Address Detection Enable</b> (NuMicro™ NUC100/NUC120 Low Density Only) This bit is use to enable RS-485 address detection mode. 1 = Enable address detection mode 0 = Disable address detection mode Note: This field is used for RS-485 any operation mode.
[14:11]	<b>Reserved</b>	Reserved
[10]	<b>RS485_AUD</b>	<b>RS-485 Auto Direction Mode (AUD)</b> (NuMicro™ NUC100/NUC120 Low Density Only) 1 = Enable RS-485 Auto Direction Operation Mode (AUO) 0 = Disable RS-485 Auto Direction Operation Mode (AUO) Note: It can be active with RS-485_AAD or RS-485_NMM operation mode.
[9]	<b>RS485_AAD</b>	<b>RS-485 Auto Address Detection Operation Mode (AAD)</b> (NuMicro™ NUC100/NUC120 Low Density Only) 1 = Enable RS-485 Auto Address Detection Operation Mode (AAD) 0 = Disable RS-485 Auto Address Detection Operation Mode (AAD) Note: It can't be active with RS-485_NMM operation mode.





Bits	Descriptions	
[8]	<b>RS485_NMM</b>	<b>RS-485 Normal Multi-drop Operation Mode (NMM)</b> (NuMicro™ NUC100/NUC120 Low Density Only) 1 = Enable RS-485 Normal Multi-drop Operation Mode (NMM) 0 = Disable RS-485 Normal Multi-drop Operation Mode (NMM) Note: It can't be active with RS-485_AAD operation mode.
[7:0]	<b>Reserved</b>	Reserved



## UART Function Select Register (UA\_FUN\_SEL)

Register	Offset	R/W	Description	Reset Value
UA_FUN_SEL	UART0_BA+0x30	R/W	UART0 Function Select Register	0x0000_0000
	UART1_BA+0x30	R/W	UART1 Function Select Register	0x0000_0000
	UART2_BA+0x30	R/W	UART2 Function Select Register	0x0000_0000

31	30	29	28	27	26	25	24
Reserved							
23	22	21	20	19	18	17	16
Reserved							
15	14	13	12	11	10	9	8
Reserved							
7	6	5	4	3	2	1	0
Reserved						FUN_SEL	

Bits	Descriptions	
[31:2]	Reserved	Reserved
[1:0]	FUN_SEL	<b>Function Select Enable</b> 00 = UART Function 01 = Reserved 10 = Enable IrDA Function 11 = Enable RS-485 Function (NuMicro™ NUC100/NUC120 Low Density Only)

## 5.13 PS/2 Device Controller (PS2D)

### 5.13.1 Overview

PS/2 device controller provides basic timing control for PS/2 communication. All communication between the device and the host is managed through the CLK and DATA pins. Unlike PS/2 keyboard or mouse device controller, the received/transmit code needs to be translated as meaningful code by firmware. The device controller generates the CLK signal after receiving a request to send, but host has ultimate control over communication. DATA sent from the host to the device is read on the rising edge and DATA sent from device to the host is change after rising edge. A 16 bytes FIFO is used to reduce CPU intervention. S/W can select 1 to 16 bytes for a continuous transmission.

### 5.13.2 Features

- Host communication inhibit and request to send detection
- Reception frame error detection
- Programmable 1 to 16 bytes transmit buffer to reduce CPU intervention
- Double buffer for data reception
- S/W override bus

5.13.3 Block Diagram

The PS/2 device controller consists of APB interface and timing control logic for DATA and CLK lines.

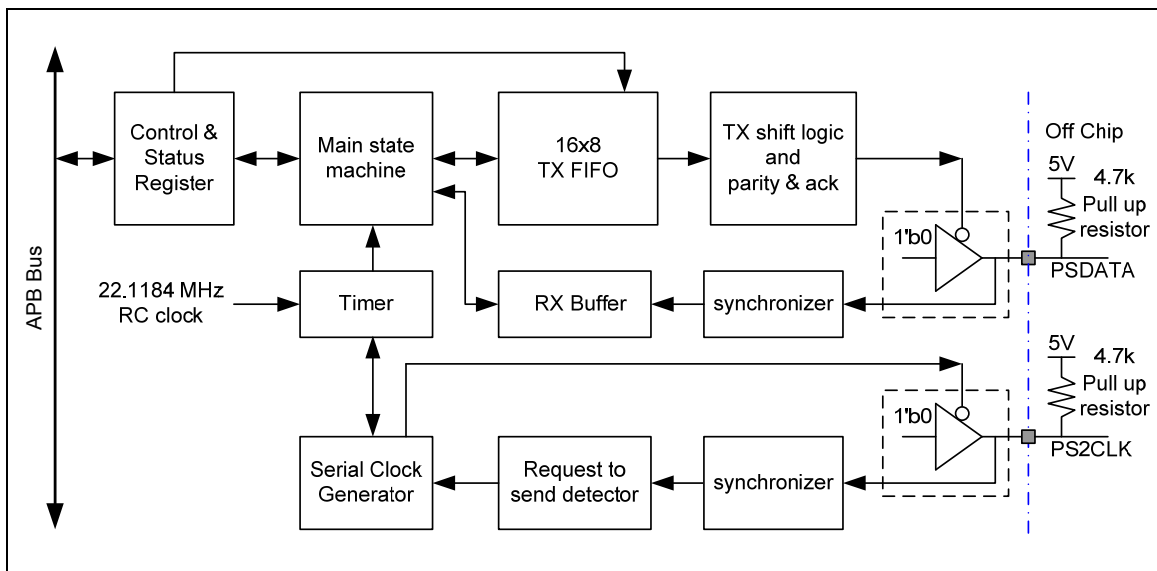

Figure 5-75 PS/2 Device Block Diagram



## 5.13.4 Functional Description

### 5.13.4.1 Communication

The PS/2 device implements a bidirectional synchronous serial protocol. The bus is "Idle" when both lines are high (open-collector). This is the only state where the device is allowed start to transmit DATA. The host has ultimate control over the bus and may inhibit communication at any time by pulling the CLK line low.

The CLK signal is generated by PS/2 device. If the host wants to send DATA, it must first inhibit communication from the device by pulling CLK low. The host then pulls DATA low and releases CLK. This is the "Request-to-Send" state and signals the device to start generating CLK pulses.

DATA	CLK	Bus State
High	High	Idle
High	Low	Communication Inhibit
Low	High	Host Request to Send

All data is transmitted one byte at a time and each byte is sent in a frame consisting of 11 or 12 bits. These bits are:

- 1 start bit. This is always 0
- 8 DATA bits, least significant bit first
- 1 parity bit (odd parity)
- 1 stop bit. This is always 1
- 1 acknowledge bit (host-to-device communication only)

The parity bit is set if there is an even number of 1's in the data bits and cleared to 0 if there is an odd number of 1's in the data bits. The number of 1's in the data bits plus the parity bit always add up to an odd number set to 1. This is used for error detection. The device must check this bit and if incorrect it should respond as if it had received an invalid command.

The host may inhibit communication at any time by pulling the CLK line low for at least 100 microseconds. If a transmission is inhibited before the 11th clock pulse, the device must abort the current transmission and prepare to retransmit the current data when host releases Clock. In order to reserve enough time for s/w to decode host command, the transmit logic is blocked by RXINT bit, S/W must clear RXINT bit to start retransmit. S/W can write CLR\_FIFO to 1 to reset FIFO pointer if need.

### Device-to-Host

The device uses a serial protocol with 11-bit frames. These bits are:

- 1 start bit. This is always 0
- 8 DATA bits, least significant bit first
- 1 parity bit (odd parity)
- 1 stop bit. This is always 1

The device writes a bit on the DATA line when CLK is high, and it is read by the host when CLK is

low. Figure 5-76 in the following illustrate this.

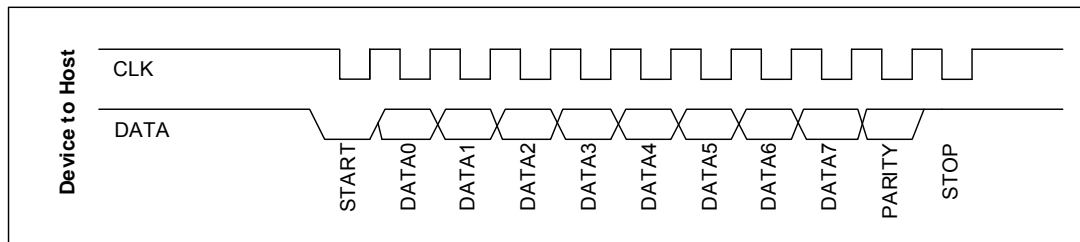

Figure 5-76 Data Format of Device-to-Host

### Host-to-Device:

First of all, the PS/2 device always generates the CLK signal. If the host wants to send DATA, it must first put the CLK and DATA lines in a "Request-to-send" state as follows:

- Inhibit communication by pulling CLK low for at least 100 microseconds
- Apply "Request-to-send" by pulling DATA low, then release CLK

The device should check for this state at intervals not to exceed 10 milliseconds. When the device detects this state, it will begin generating CLK signals and CLK in eight DATA bits and one stop bit. The host changes the DATA line only when the CLK line is low, and DATA is read by the device when CLK is high.

After the stop bit is received, the device will acknowledge the received byte by bringing the DATA line low and generating one last CLK pulse. If the host does not release the DATA line after the 11th CLK pulse, the device will continue to generate CLK pulses until the DATA line is released.

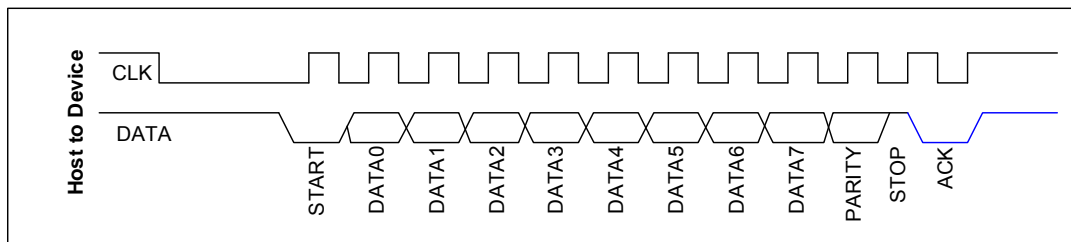

Figure 5-77 Data Format of Host-to-Device



The host and the device DATA and CLK detailed timing for communication is shown as below:

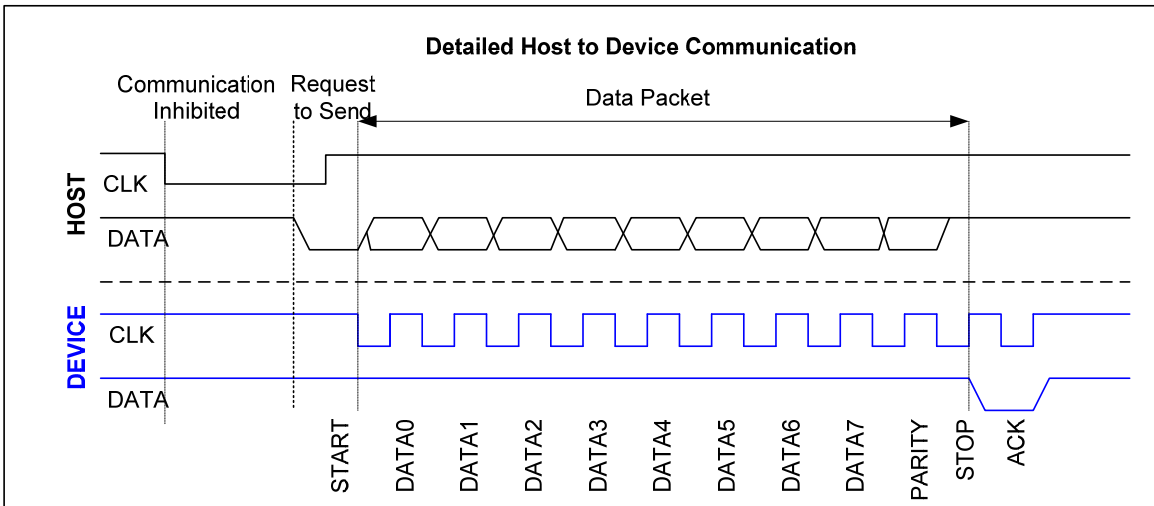

Figure 5-78 PS/2 Bit Data Format

5.13.4.2 PS/2 Bus Timing Specification

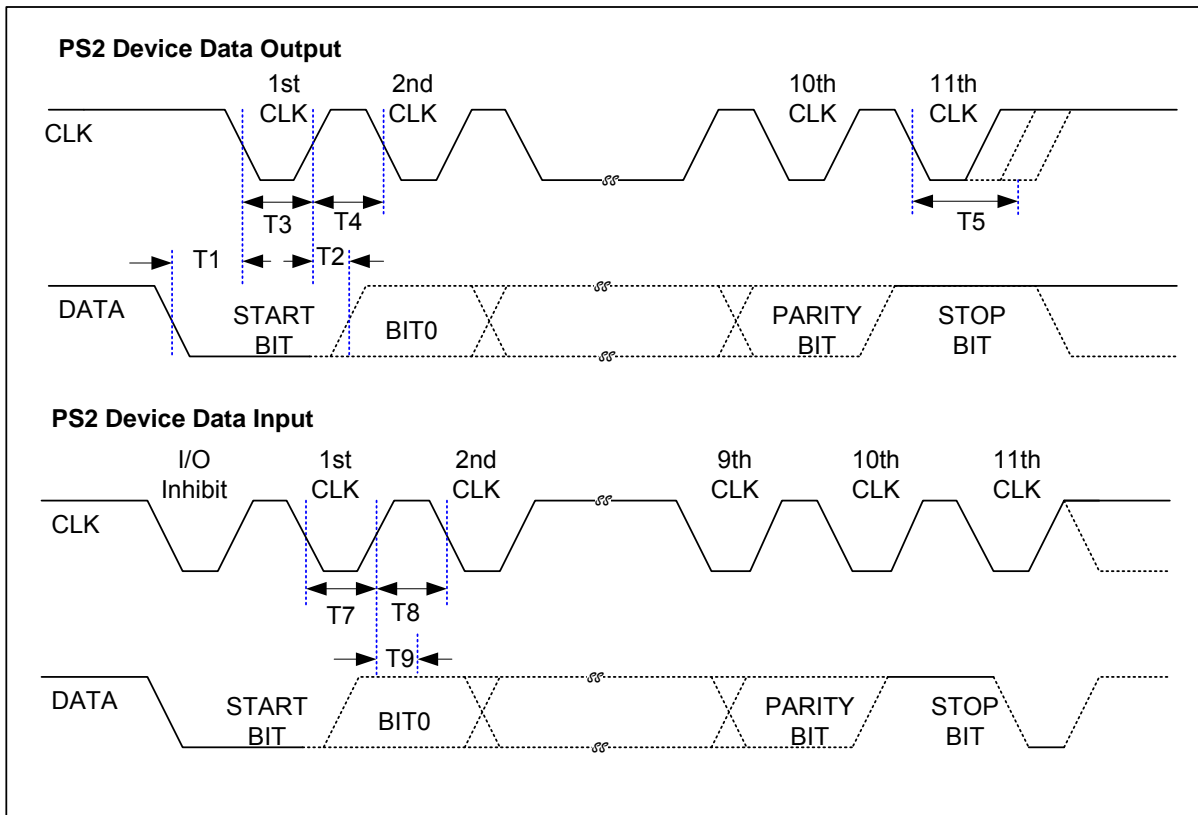

Figure 5-79 PS/2 Bus Timing



Symbol	Timing Parameter	Min	Max
T1	DATA transition to the falling edge of CLK	5us	25us
T2	Rising edge of CLK to DATA transition	5us	T4-5us
T3	Duration of CLK inactive	30us	50us
T4	Duration of CLK active	30us	50us
T5	Time to auxiliary device inhibit after 11 <sup>th</sup> clock to ensure auxiliary device does not start another transmission	>0	50us
T7	Duration of CLK inactive	30us	50us
T8	Duration of CLK active	30us	50us
T9	Time from inactive to active CLK transition, use to time auxiliary device sample DATA	5us	25us



5.13.4.3 TX FIFO Operation

Writing PS2TXDATA0 register starts device to host communication. S/W is required to define TXFIFO depth before writing transmission data to TX FIFO. 1st START bit is sent to PS/2 bus 100us after S/W writes TX FIFO, if there is more than 4 bytes data need to be sent, S/W can write residual data to PS2TXDATA1-3 before 4th byte transmit complete. A time delay 100us is added between two consecutive bytes.

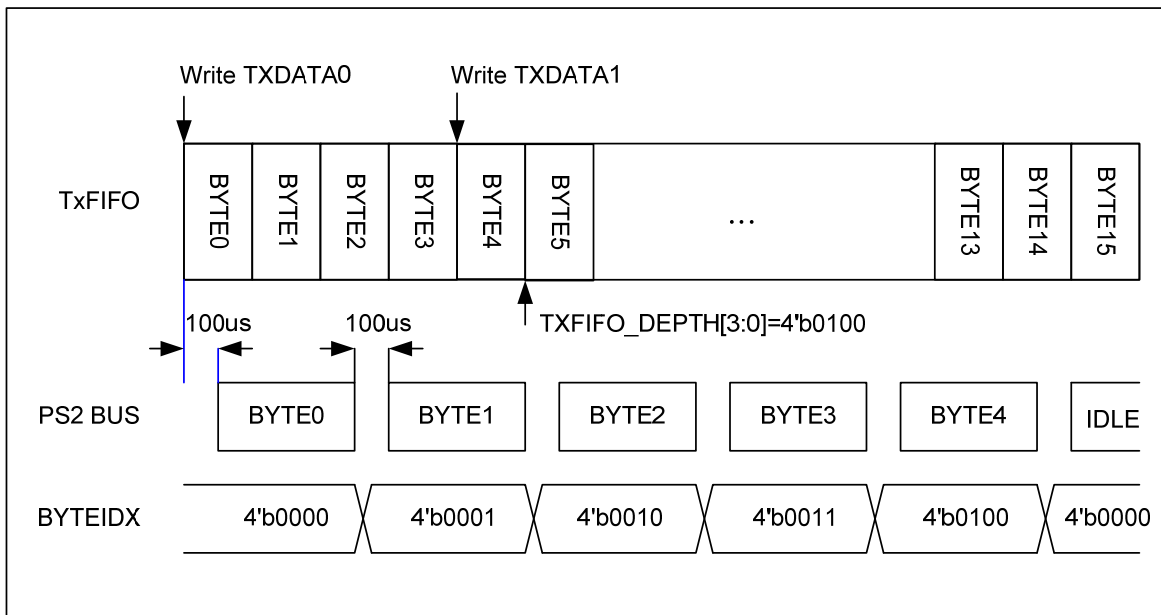

Figure 5-80 PS/2 Data Format



### 5.13.5 Register Map

R: read only, W: write only, R/W: both read and write

Register	Offset	R/W	Description	Reset Value
<b>PS2_BA: 0x4010_0000</b>				
<b>PS2CON</b>	PS2_BA+0x00	R/W	PS/2 Control Register	0x0000_0000
<b>PS2TXDATA0</b>	PS2_BA+0x04	R/W	PS/2 Transmit DATA Register 0	0x0000_0000
<b>PS2TXDATA1</b>	PS2_BA+0x08	R/W	PS/2 Transmit DATA Register 1	0x0000_0000
<b>PS2TXDATA2</b>	PS2_BA+0x0C	R/W	PS/2 Transmit DATA Register 2	0x0000_0000
<b>PS2TXDATA3</b>	PS2_BA+0x10	R/W	PS/2 Transmit DATA Register 3	0x0000_0000
<b>PS2RXDATA</b>	PS2_BA+0x14	R	PS/2 Receive DATA Register	0x0000_0000
<b>PS2STATUS</b>	PS2_BA+0x18	R/W	PS/2 Status Register	0x0000_0083
<b>PS2INTID</b>	PS2_BA+0x1C	R/W	PS/2 Interrupt Identification Register	0x0000_0000



5.13.6 Register Description

**PS/2 Control Register (PS2CON)**

Register	Offset	R/W	Description	Reset Value
PS2CON	PS2_BA+0x00	R/W	PS/2 Control Register	0x0000_0000

31	30	29	28	27	26	25	24
Reserved							
23	22	21	20	19	18	17	16
Reserved							
15	14	13	12	11	10	9	8
Reserved				FPS2DAT	FPS2CLK	OVERRIDE	CLR_FIFO
7	6	5	4	3	2	1	0
ACK	TX_FIFO_DEPTH				RXINTEN	TXINTEN	PS2EN

Bits	Descriptions	
[31:12]	Reserved	Reserved
[11]	FPS2DAT	<p><b>Force PS2DATA Line</b></p> <p>It forces PS2DATA high or low regardless of the internal state of the device controller if OVERRIDE is set to high.</p> <p>1 = Force PS2DATA high</p> <p>0 = Force PS2DATA low</p>
[10]	FPS2CLK	<p><b>Force PS2CLK Line</b></p> <p>It forces PS2CLK line high or low regardless of the internal state of the device controller if OVERRIDE is set to high.</p> <p>1 = Force PS2CLK line high</p> <p>0 = Force PS2CLK line low</p>
[9]	OVERRIDE	<p><b>Software Override PS/2 CLK/DATA Pin State</b></p> <p>1 = PS2CLK and PS2DATA pins are controlled by S/W</p> <p>0 = PS2CLK and PS2DATA pins are controlled by internal state machine.</p>
[8]	CLR_FIFO	<p><b>Clear TX FIFO</b></p> <p>Write 1 to this bit to terminate device to host transmission. The TXEMPTY bit in PS2STATUS bit will be set to 1 and pointer BYTEIDEX is reset to 0 regardless there is residue data in buffer or not. The buffer content is not been cleared.</p> <p>1 = Clear FIFO</p> <p>0 = Not active</p>
[7]	ACK	<b>Acknowledge Enable</b>



Bits	Descriptions	
		1 = If parity error or stop bit is not received correctly, acknowledge bit will not be sent to host at 12th clock 0 = Always send acknowledge to host at 12th clock for host to device communication.
[6:3]	<b>TXFIFODIPTH</b>	<b>Transmit Data FIFO Depth</b> There is 16 bytes buffer for data transmit. S/W can define the FIFO depth from 1 to 16 bytes depends on application. 0 = 1 byte 1 = 2 bytes ... 14 = 15 bytes 15 = 16 bytes
[2]	<b>RXINTEN</b>	<b>Enable Receive Interrupt</b> 1 = Enable data receive complete interrupt 0 = Disable data receive complete interrupt
[1]	<b>TXINTEN</b>	<b>Enable Transmit Interrupt</b> 1 = Enable data transmit complete interrupt 0 = Disable data transmit complete interrupt
[0]	<b>PS2EN</b>	<b>Enable PS/2 Device</b> Enable PS/2 device controller 1 = Enable 0 = Disable



## PS/2 TX DATA Register 0-3 (PS2TXDATA0-3)

Register	Offset	R/W	Description	Reset Value
PS2TXDATA0	PS2_BA+0x04	R/W	PS/2 Transmit Data Register0	0x0000_0000
PS2TXDATA1	PS2_BA+0x08	R/W	PS/2 Transmit Data Register1	0x0000_0000
PS2TXDATA2	PS2_BA+0x0C	R/W	PS/2 Transmit Data Register2	0x0000_0000
PS2TXDATA3	PS2_BA+0x10	R/W	PS/2 Transmit Data Register3	0x0000_0000

31	30	29	28	27	26	25	24
PS2TXDATAx[31:24]							
23	22	21	20	19	18	17	16
PS2TXDATAx[23:16]							
15	14	13	12	11	10	9	8
PS2TXDATAx[15:8]							
7	6	5	4	3	2	1	0
PS2TXDATAx[7:0]							

Bits	Descriptions	
[31:0]	PS2TXDATAx	<b>Transmit data</b> Write data to this register starts device to host communication if bus is in IDLE state. S/W must enable PS2EN before writing data to TX buffer.



## PS/2 Receiver DATA Register (PS2RXDATA)

Register	Offset	R/W	Description	Reset Value
PS2RXDATA	PS2_BA+0x14	R	PS/2 Receive Data Register	0x0000_0000

31	30	29	28	27	26	25	24
Reserved							
23	22	21	20	19	18	17	16
Reserved							
15	14	13	12	11	10	9	8
Reserved							
7	6	5	4	3	2	1	0
RXDATA[7:0]							

Bits	Descriptions	
[31:8]	Reserved	Reserved
[7:0]	PS2RXDATA	<b>Received Data</b> For host to device communication, after acknowledge bit is sent, the received data is copied from receive shift register to PS2RXDATA register. CPU must read this register before next byte reception complete, otherwise the data will be overwritten and RXOVF bit in PS2STATUS[6] will be set to 1.



## PS/2 Status Register (PS2STATUS)

Register	Offset	R/W	Description	Reset Value
PS2STATUS	PS2_BA+0x18	R/W	PS/2 Status Register	0x0000_0000

31	30	29	28	27	26	25	24
Reserved							
23	22	21	20	19	18	17	16
Reserved							
15	14	13	12	11	10	9	8
Reserved				BYTEIDX[3:0]			
7	6	5	4	3	2	1	0
TXEMPTY	RXOVF	TXBUSY	RXBUSY	RXPARTY	FRAMERR	PS2DATA	PS2CLK

Bits	Descriptions																																					
[31:12]	Reserved	Reserved																																				
[11:8]	BYTEIDX	<p><b>Byte Index</b></p> <p>It indicates which data byte in transmit data shift register. When all data in FIFO is transmitted and it will be cleared to 0.</p> <p>It is a read only bit.</p> <table border="1" style="width: 100%; text-align: center;"> <thead> <tr> <th>BYTEIDX</th> <th>DATA Transmit</th> <th>BYTEIDX</th> <th>DATA Transmit</th> </tr> </thead> <tbody> <tr> <td>0000</td> <td>TXDATA0[7:0]</td> <td>1000</td> <td>TXDATA2[7:0]</td> </tr> <tr> <td>0001</td> <td>TXDATA0[15:8]</td> <td>1001</td> <td>TXDATA2[15:8]</td> </tr> <tr> <td>0010</td> <td>TXDATA0[23:16]</td> <td>1010</td> <td>TXDATA2[23:16]</td> </tr> <tr> <td>0011</td> <td>TXDATA0[31:24]</td> <td>1011</td> <td>TXDATA2[31:24]</td> </tr> <tr> <td>0100</td> <td>TXDATA1[7:0]</td> <td>1100</td> <td>TXDATA3[7:0]</td> </tr> <tr> <td>0101</td> <td>TXDATA1[15:8]</td> <td>1101</td> <td>TXDATA3[15:8]</td> </tr> <tr> <td>0110</td> <td>TXDATA1[23:16]</td> <td>1110</td> <td>TXDATA3[23:16]</td> </tr> <tr> <td>0111</td> <td>TXDATA1[31:24]</td> <td>1111</td> <td>TXDATA3[31:24]</td> </tr> </tbody> </table>	BYTEIDX	DATA Transmit	BYTEIDX	DATA Transmit	0000	TXDATA0[7:0]	1000	TXDATA2[7:0]	0001	TXDATA0[15:8]	1001	TXDATA2[15:8]	0010	TXDATA0[23:16]	1010	TXDATA2[23:16]	0011	TXDATA0[31:24]	1011	TXDATA2[31:24]	0100	TXDATA1[7:0]	1100	TXDATA3[7:0]	0101	TXDATA1[15:8]	1101	TXDATA3[15:8]	0110	TXDATA1[23:16]	1110	TXDATA3[23:16]	0111	TXDATA1[31:24]	1111	TXDATA3[31:24]
		BYTEIDX	DATA Transmit	BYTEIDX	DATA Transmit																																	
		0000	TXDATA0[7:0]	1000	TXDATA2[7:0]																																	
		0001	TXDATA0[15:8]	1001	TXDATA2[15:8]																																	
		0010	TXDATA0[23:16]	1010	TXDATA2[23:16]																																	
		0011	TXDATA0[31:24]	1011	TXDATA2[31:24]																																	
		0100	TXDATA1[7:0]	1100	TXDATA3[7:0]																																	
		0101	TXDATA1[15:8]	1101	TXDATA3[15:8]																																	
		0110	TXDATA1[23:16]	1110	TXDATA3[23:16]																																	
0111	TXDATA1[31:24]	1111	TXDATA3[31:24]																																			
[7]	TXEMPTY	<p><b>TX FIFO Empty</b></p> <p>When S/W writes any data to PS2TXDATA0-3 the TXEMPTY bit is cleared to 0 immediately if PS2EN is enabled. When transmitted data byte number is equal to FIFODEPTH then TXEMPTY bit is set to 1.</p> <p>1 = FIFO is empty 0 = There is data to be transmitted</p> <p>Read only bit.</p>																																				
[6]	RXOVF	<b>RX Buffer Overwrite</b>																																				



Bits	Descriptions	
		<p>1 = Data in PS2RXDATA register is overwritten by new received data</p> <p>0 = No overwrite</p> <p>Write 1 to clear this bit.</p>
[5]	<b>TXBUSY</b>	<p><b>Transmit Busy</b></p> <p>This bit indicates that the PS/2 device is currently sending data.</p> <p>1 = Currently sending data</p> <p>0 = Idle</p> <p>Read only bit.</p>
[4]	<b>RXBUSY</b>	<p><b>Receive Busy</b></p> <p>This bit indicates that the PS/2 device is currently receiving data.</p> <p>1 = Currently receiving data</p> <p>0 = Idle</p> <p>Read only bit.</p>
[3]	<b>RXPARTY</b>	<p><b>Received Parity</b></p> <p>This bit reflects the parity bit for the last received data byte (odd parity).</p> <p>Read only bit.</p>
[2]	<b>FRAMERR</b>	<p><b>Frame Error</b></p> <p>For host to device communication, if STOP bit (logic 1) is not received it is a frame error. If frame error occurs, DATA line may keep at low state after 12th clock. At this moment, S/W overrides PS2CLK to send clock till PS2DATA release to high state. After that, device sends a "Resend" command to host.</p> <p>1 = Frame error occur</p> <p>0 = No frame error</p> <p>Write 1 to clear this bit.</p>
[1]	<b>PS2DATA</b>	<p><b>DATA Pin State</b></p> <p>This bit reflects the status of the PS2DATA line after synchronizing and sampling.</p>
[0]	<b>PS2CLK</b>	<p><b>CLK Pin State</b></p> <p>This bit reflects the status of the PS2CLK line after synchronizing.</p>





## PS/2 Interrupt Identification Register (PS2INTID)

Register	Offset	R/W	Description	Reset Value
PS2INTID	PS2_BA+0x1C	R/W	PS/2 Interrupt Identification Register	0x0000_0000

31	30	29	28	27	26	25	24
Reserved							
23	22	21	20	19	18	17	16
Reserved							
15	14	13	12	11	10	9	8
Reserved							
7	6	5	4	3	2	1	0
Reserved						TXINT	RXINT

Bits	Descriptions	
[31:3]	Reserved	Reserved
[1]	TXINT	<p><b>Transmit Interrupt</b></p> <p>This bit is set to 1 after STOP bit is transmitted. Interrupt occur if TXINTEN bit is set to 1.</p> <p>1 = Transmit interrupt occurs</p> <p>0 = No interrupt</p> <p>Write 1 to clear this bit to 0.</p>
[0]	RXINT	<p><b>Receive Interrupt</b></p> <p>This bit is set to 1 when acknowledge bit is sent for Host to device communication. Interrupt occurs if RXINTEN bit is set to 1.</p> <p>1 = Receive interrupt occurs</p> <p>0 = No interrupt</p> <p>Write 1 to clear this bit to 0.</p>



## 5.14 I<sup>2</sup>S Controller (I<sup>2</sup>S)

### 5.14.1 Overview

The I<sup>2</sup>S controller consists of IIS protocol to interface with external audio CODEC. Two 8 word deep FIFO for read path and write path respectively and is capable of handling 8 ~ 32 bit word sizes. DMA controller handles the data movement between FIFO and memory.

### 5.14.2 Features

- I<sup>2</sup>S can operate as either master or slave
- Capable of handling 8-, 16-, 24- and 32-bit word sizes
- Mono and stereo audio data supported
- I<sup>2</sup>S and MSB justified data format supported
- Two 8 word FIFO data buffers are provided, one for transmit and one for receive
- Generates interrupt requests when buffer levels cross a programmable boundary
- Two DMA requests, one for transmit and one for receive

## 5.14.3 Block Diagram

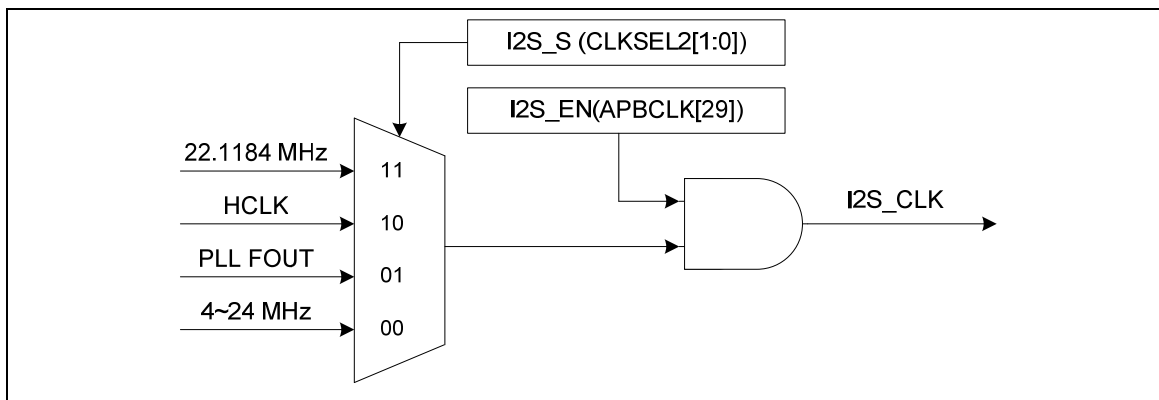

Figure 5-81 I²S Clock Control Diagram

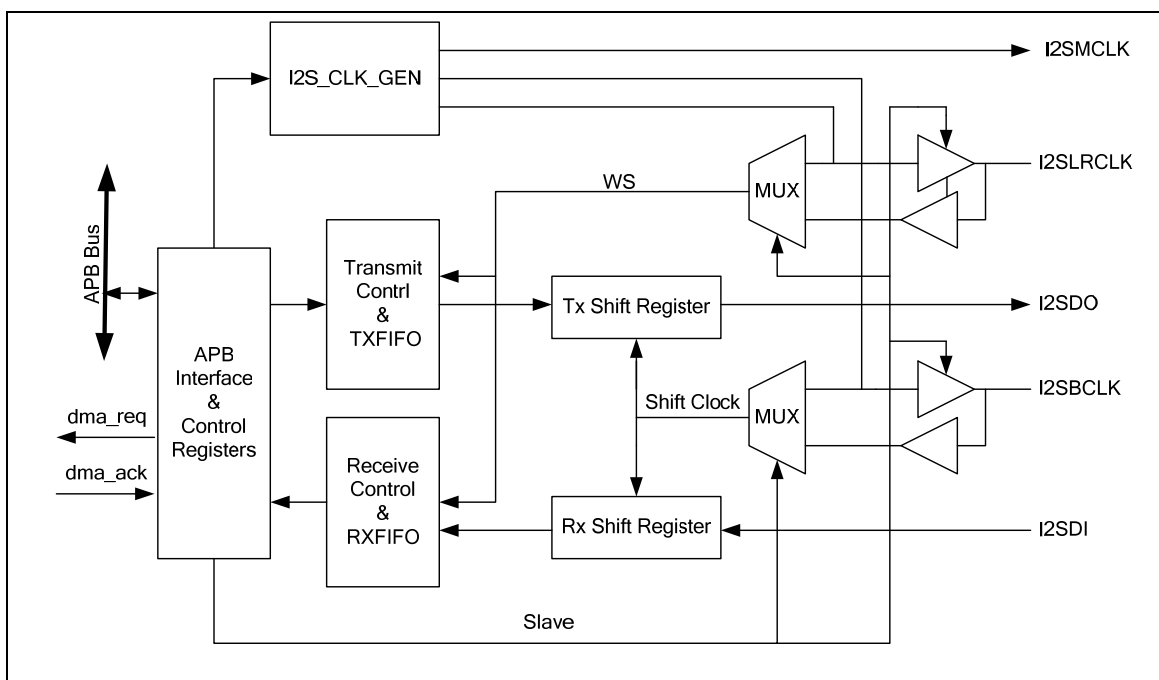

Figure 5-82 I²S Controller Block Diagram

5.14.4 Functional Description

5.14.4.1 I<sup>2</sup>S Operation

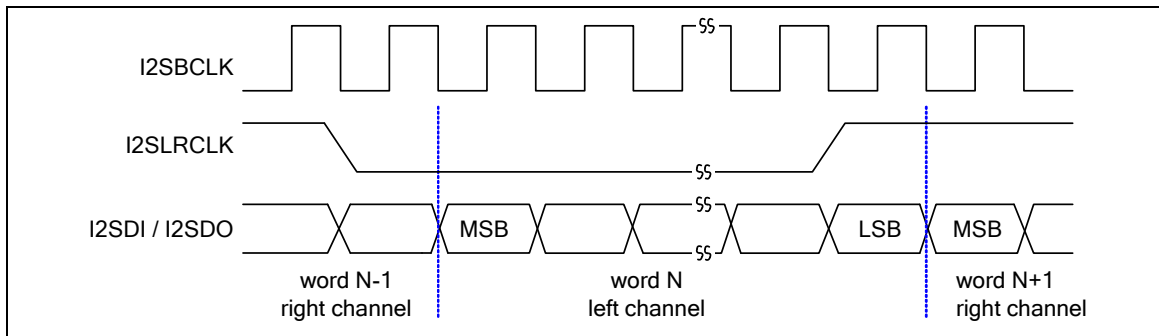

Figure 5-83 I<sup>2</sup>S Bus Timing Diagram (Format=0)

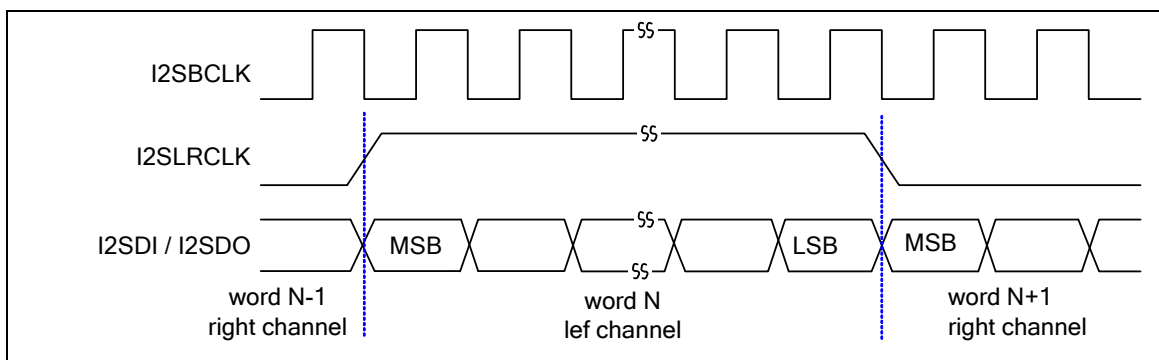

Figure 5-84 MSB Justified Timing Diagram (Format=1)

5.14.4.2 FIFO operation

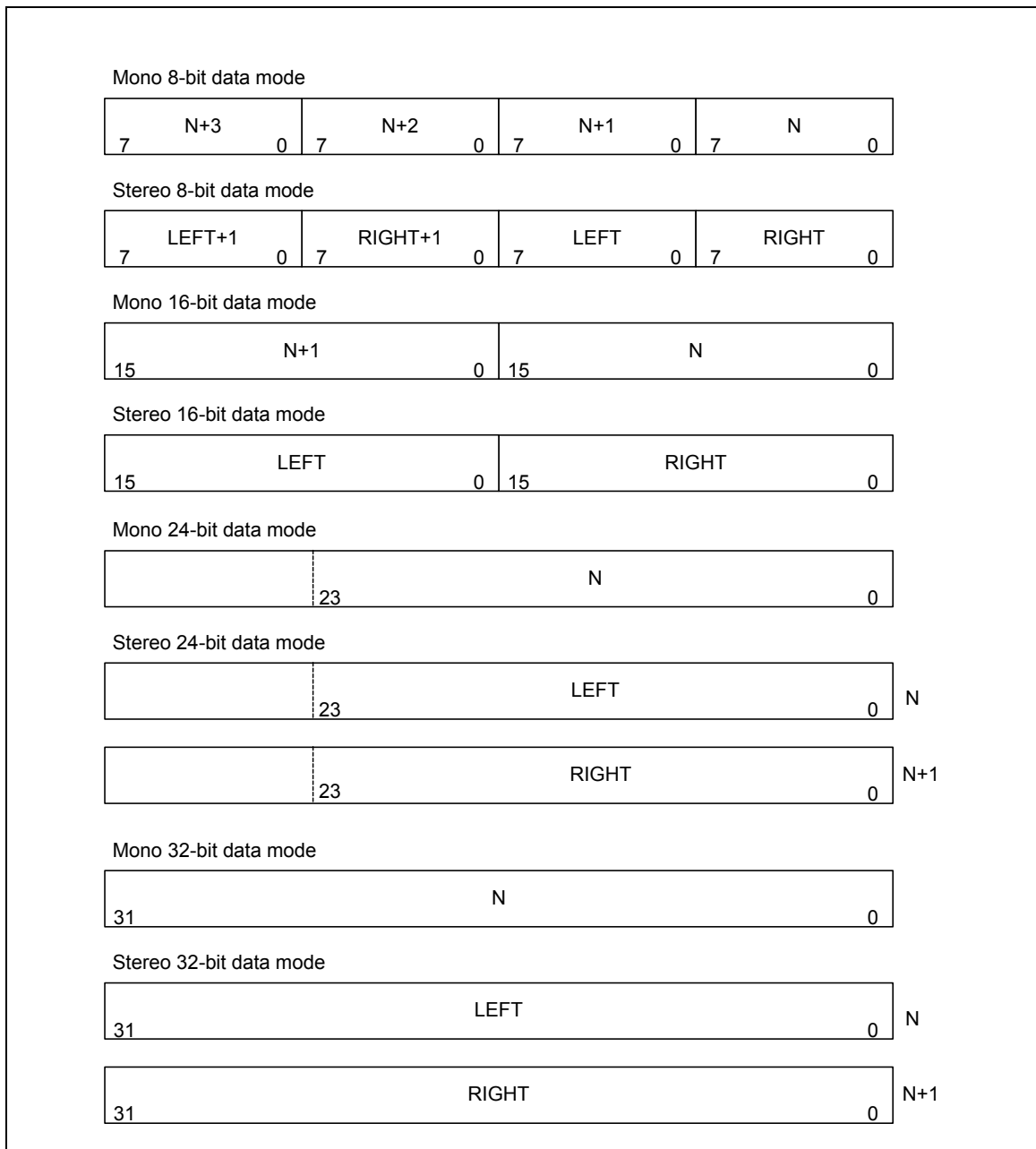

Figure 5-85 FIFO contents for various I<sup>2</sup>S modes



### 5.14.5 Register Map

R: read only, W: write only, R/W: both read and write

Register	Offset	R/W	Description	Reset Value
<b>I2S_BA = 0x401A_0000</b>				
<b>I2SCON</b>	I2S_BA+0x00	R/W	I <sup>2</sup> S Control Register	0x0000_0000
<b>I2SCLKDIV</b>	I2S_BA+0x04	R/W	I <sup>2</sup> S Clock Divider Register	0x0000_0000
<b>I2SIE</b>	I2S_BA+0x08	R/W	I <sup>2</sup> S Interrupt Enable Register	0x0000_0000
<b>I2SSTATUS</b>	I2S_BA+0x0C	R/W	I <sup>2</sup> S Status Register	0x0014_1000
<b>I2STXFIFO</b>	I2S_BA+0x10	W	I <sup>2</sup> S Transmit FIFO Register	0x0000_0000
<b>I2SRXFIFO</b>	I2S_BA+0x14	R	I <sup>2</sup> S Receive FIFO Register	0x0000_0000



5.14.6 Register Description

**I<sup>2</sup>S Control Register (I2SCON)**

Register	Offset	R/W	Description	Reset Value
I2SCON	I2S_BA+0x00	R/W	I <sup>2</sup> S Control Register	0x0000_0000

31	30	29	28	27	26	25	24
Reserved							
23	22	21	20	19	18	17	16
Reserved	Reserved	RXDMA	TXDMA	CLR_RXFIFO	CLR_TXFIFO	LCHZCEN	RCHZCEN
15	14	13	12	11	10	9	8
MCLKEN	RXTH[2:0]			TXTH[2:0]			SLAVE
7	6	5	4	3	2	1	0
FORMAT	MONO	WORDWIDTH		MUTE	RXEN	TXEN	I2SEN

Bits	Descriptions	
[31:22]	Reserved	Reserved
[21]	RXDMA	<p><b>Enable Receive DMA</b></p> <p>When RX DMA is enabled, I<sup>2</sup>S requests DMA to transfer data from receive FIFO to SRAM if FIFO is not empty.</p> <p>1 = Enable RX DMA 0 = Disable RX DMA</p>
[20]	TXDMA	<p><b>Enable Transmit DMA</b></p> <p>When TX DMA is enables, I<sup>2</sup>S request DMA to transfer data from SRAM to transmit FIFO if FIFO is not full.</p> <p>1 = Enable TX DMA 0 = Disable TX DMA</p>
[19]	CLR_RXFIFO	<p><b>Clear Receive FIFO</b></p> <p>Write 1 to clear receive FIFO, internal pointer is reset to FIFO start point, and RXFIFO_LEVEL[3:0] returns to zero and receive FIFO becomes empty.</p> <p>This bit is cleared by hardware automatically, read it return zero.</p>
[18]	CLR_TXFIFO	<p><b>Clear Transmit FIFO</b></p> <p>Write 1 to clear transmit FIFO, internal pointer is reset to FIFO start point, and TXFIFO_LEVEL[3:0] returns to zero and transmit FIFO becomes empty but data in transmit FIFO is not changed.</p> <p>This bit is clear by hardware automatically, read it return zero.</p>



Bits	Descriptions	
[17]	<b>LCHZCEN</b>	<p><b>Left channel zero cross detect enable</b></p> <p>If this bit is set to 1, when left channel data sign bit change or next shift data bits are all zero then LZCF flag in I2SSTATUS register is set to 1.</p> <p>1 = Enable left channel zero cross detect 0 = Disable left channel zero cross detect</p>
[16]	<b>RCHZCEN</b>	<p><b>Right channel zero cross detect enable</b></p> <p>If this bit is set to 1, when right channel data sign bit change or next shift data bits are all zero then RZCF flag in I2SSTATUS register is set to 1.</p> <p>1 = Enable right channel zero cross detect 0 = Disable right channel zero cross detect</p>
[15]	<b>MCLKEN</b>	<p><b>Master clock enable</b></p> <p>If NuMicro™ NUC100 series, external crystal clock is frequency 2*N*256fs then software can program MCLK_DIV[2:0] in I2SCLKDIV register to get 256fs clock to audio codec chip.</p> <p>1 = Enable master clock 0 = Disable master clock</p>
[14:12]	<b>RXTH[2:0]</b>	<p><b>Receive FIFO threshold level</b></p> <p>When received data word(s) in buffer is equal or higher than threshold level then RXTHF flag is set.</p> <p>000 = 1 word data in receive FIFO 001 = 2 word data in receive FIFO 010 = 3 word data in receive FIFO 011 = 4 word data in receive FIFO 100 = 5 word data in receive FIFO 101 = 6 word data in receive FIFO 110 = 7 word data in receive FIFO 111 = 8 word data in receive FIFO</p>
[11:9]	<b>TXTH[2:0]</b>	<p><b>Transmit FIFO threshold level</b></p> <p>If remain data word (32 bits) in transmit FIFO is the same or less than threshold level then TXTHF flag is set.</p> <p>000 = 0 word data in transmit FIFO 001 = 1 word data in transmit FIFO 010 = 2 words data in transmit FIFO 011 = 3 words data in transmit FIFO 100 = 4 words data in transmit FIFO 101 = 5 words data in transmit FIFO 110 = 6 words data in transmit FIFO 111 = 7 words data in transmit FIFO</p>





Bits	Descriptions	
[8]	<b>SLAVE</b>	<p><b>Slave mode</b></p> <p>I<sup>2</sup>S can operate as master or slave. For master mode, I2S_BCLK and I2S_LRCLK pins are output mode and send bit clock from NuMicro™ NUC100 series to Audio CODEC chip. In slave mode, I2S_BCLK and I2S_LRCLK pins are input mode and I2S_BCLK and I2S_LRCLK signals are received from outer Audio CODEC chip.</p> <p>1 = Slave mode 0 = Master mode</p>
[7]	<b>FORMAT</b>	<p><b>Data format</b></p> <p>1 = MSB justified data format 0 = I<sup>2</sup>S data format</p>
[6]	<b>MONO</b>	<p><b>Monaural data</b></p> <p>1 = Data is monaural format 0 = Data is stereo format</p> <p>Note: when chip record data, only right channel data will be save if monaural format is select.</p>
[5:4]	<b>WORDWIDTH</b>	<p><b>Word width</b></p> <p>00 = data is 8-bit 01 = data is 16-bit 10 = data is 24-bit 11 = data is 32-bit</p>
[3]	<b>MUTE</b>	<p><b>Transmit mute enable</b></p> <p>1= Transmit channel zero 0 = Transmit data is shifted from buffer</p>
[2]	<b>RXEN</b>	<p><b>Receive enable</b></p> <p>1 = Enable data receive 0 = Disable data receive</p>
[1]	<b>TXEN</b>	<p><b>Transmit enable</b></p> <p>1 = Enable data transmit 0 = Disable data transmit</p>
[0]	<b>I2SEN</b>	<p><b>Enable I<sup>2</sup>S controller</b></p> <p>1 = Enable 0 = Disable</p>



## I<sup>2</sup>S Clock Divider (I2SCLKDIV)

Register	Offset	R/W	Description	Reset Value
I2SCLKDIV	I2S_BA+0x04	R/W	I <sup>2</sup> S Clock Divider Control Register	0x0000_0000

31	30	29	28	27	26	25	24
Reserved							
23	22	21	20	19	18	17	16
Reserved							
15	14	13	12	11	10	9	8
BCLK_DIV [7:0]							
7	6	5	4	3	2	1	0
Reserved				MCLK_DIV[2:0]			

Bits	Descriptions	
[31:16]	Reserved	Reserved
[15:8]	BCLK_DIV [7:0]	<p><b>Bit Clock Divider</b></p> <p>If I<sup>2</sup>S operates in master mode, bit clock is provided by NuMicro™ NUC100 series. Software can program these bits to generate sampling rate clock frequency.</p> $F\_BCLK = F\_I2SCLK / (2 \times (BCLK\_DIV + 1))$
[7:3]	Reserved	Reserved
[2:0]	MCLK_DIV[2:0]	<p><b>Master Clock Divider</b></p> <p>If chip external crystal frequency is <math>(2 \times MCLK\_DIV) \times 256fs</math> then software can program these bits to generate 256fs clock frequency to audio codec chip. If MCLK_DIV is set to 0, MCLK is the same as external clock input.</p> <p>For example, sampling rate is 24 kHz and chip external crystal clock is 12.288 MHz, set MCLK_DIV=1.</p> $F\_MCLK = F\_I2SCLK / (2 \times (MCLK\_DIV)) \text{ (When } MCLK\_DIV \text{ is } \geq 1 \text{)}$ $F\_MCLK = F\_I2SCLK \text{ (When } MCLK\_DIV \text{ is set to } 0 \text{)}$



## I<sup>2</sup>S Interrupt Enable Register (I2SIE)

Register	Offset	R/W	Description	Reset Value
I2SIE	I2S_BA+0x08	R/W	I <sup>2</sup> S Interrupt Enable Register	0x0000_0000

31	30	29	28	27	26	25	24
Reserved							
23	22	21	20	19	18	17	16
Reserved							
15	14	13	12	11	10	9	8
Reserved			LZCIE	RZCIE	TXTHIE	TXOVFIE	TXUDFIE
7	6	5	4	3	2	1	0
Reserved					RXTHIE	RXOVFIE	RXUDFIE

Bits	Descriptions	
[31:13]	Reserved	Reserved
[12]	LZCIE	<b>Left channel zero cross interrupt enable</b> Interrupt occur if this bit is set to 1 and left channel zero cross 1 = Enable interrupt 0 = Disable interrupt
[11]	RZCIE	<b>Right channel zero cross interrupt enable</b> 1 = Enable interrupt 0 = Disable interrupt
[10]	TXTHIE	<b>Transmit FIFO threshold level interrupt enable</b> Interrupt occurs if this bit is set to 1 and data words in transmit FIFO is less than TXTH[2:0]. 1 = Enable interrupt 0 = Disable interrupt
[9]	TXOVFIE	<b>Transmit FIFO overflow interrupt enable</b> Interrupt occurs if this bit is set to 1 and transmit FIFO overflow flag is set to 1 1 = Enable interrupt 0 = Disable interrupt
[8]	TXUDFIE	<b>Transmit FIFO underflow interrupt enable</b> Interrupt occur if this bit is set to 1 and transmit FIFO underflow flag is set to 1. 1 = Enable interrupt 0 = Disable interrupt
[7:3]	Reserved	Reserved



Bits	Descriptions	
[2]	<b>RXTHIE</b>	<p><b>Receive FIFO threshold level interrupt enable</b></p> <p>When data word in receive FIFO is equal or higher then RXTH[2:0] and the RXTHF bit is set to 1. If RXTHIE bit is enabled, interrupt occur.</p> <p>1 = Enable interrupt 0 = Disable interrupt</p>
[1]	<b>RXOVFIE</b>	<p><b>Receive FIFO overflow interrupt enable</b></p> <p>1 = Enable interrupt 0 = Disable interrupt</p>
[0]	<b>RXUDFIE</b>	<p><b>Receive FIFO underflow interrupt enable</b></p> <p>If software read receive FIFO when it is empty then RXUDF flag in I2SSTATUS register is set to 1.</p> <p>1 = Enable interrupt 0 = Disable interrupt</p>



## I<sup>2</sup>S Status Register (I2SSTATUS)

Register	Offset	R/W	Description	Reset Value
I2SSTATUS	I2S_BA+0x0C	R/W	I <sup>2</sup> S Status Register	0x0014_1000

31	30	29	28	27	26	25	24
TX_LEVEL[3:0]				RX_LEVEL[3:0]			
23	22	21	20	19	18	17	16
LZCF	RZCF	TXBUSY	TXEMPTY	TXFULL	TXTHF	TXOVF	TXUDF
15	14	13	12	11	10	9	8
Reserved			RXEMPTY	RXFULL	RXTHF	RXOVF	RXUDF
7	6	5	4	3	2	1	0
Reserved				RIGHT	I2STXINT	I2SRXINT	I2SINT

Bits	Descriptions	
[31:28]	TX_LEVEL	<p><b>Transmit FIFO level</b></p> <p>These bits indicate word number in transmit FIFO</p> <p>0000 = No data</p> <p>0001 = 1 word in transmit FIFO</p> <p>....</p> <p>1000 = 8 words in transmit FIFO</p>
[27:24]	RX_LEVEL	<p><b>Receive FIFO level</b></p> <p>These bits indicate word number in receive FIFO</p> <p>0000 = No data</p> <p>0001 = 1 word in receive FIFO</p> <p>....</p> <p>1000 = 8 words in receive FIFO</p>
[23]	LZCF	<p><b>Left channel zero cross flag</b></p> <p>It indicates left channel next sample data sign bit is changed or all data bits are zero.</p> <p>1 = Left channel zero cross is detected</p> <p>0 = No zero cross</p> <p>Software can write 1 to clear this bit to zero</p>
[22]	RZCF	<p><b>Right channel zero cross flag</b></p> <p>It indicates right channel next sample data sign bit is changed or all data bits are zero.</p> <p>1 = Right channel zero cross is detected</p> <p>0 = No zero cross</p> <p>Software can write 1 to clear this bit to zero</p>



Bits	Descriptions	
[21]	<b>TXBUSY</b>	<p><b>Transmit Busy</b></p> <p>This bit is clear to 0 when all data in transmit FIFO and shift buffer is shifted out. And set to 1 when 1st data is load to shift buffer.</p> <p>1 = Transmit shift buffer is busy 0 = Transmit shift buffer is empty</p> <p>This bit is read only.</p>
[20]	<b>TXEMPTY</b>	<p><b>Transmit FIFO empty</b></p> <p>This bit reflect data word number in transmit FIFO is zero</p> <p>1 = Empty 0 = Not empty</p> <p>This bit is read only.</p>
[19]	<b>TXFULL</b>	<p><b>Transmit FIFO full</b></p> <p>This bit reflect data word number in transmit FIFO is 8</p> <p>1 = Full. 0 = Not full.</p> <p>This bit is read only</p>
[18]	<b>TXTHF</b>	<p><b>Transmit FIFO threshold flag</b></p> <p>When data word(s) in transmit FIFO is equal or lower than threshold value set in TXTH[2:0] the TXTHF bit becomes to 1. It keeps at 1 till TXFIFO_LEVEL[3:0] is higher than TXTH[1:0] after software write TXFIFO register.</p> <p>1 = Data word(s) in FIFO is equal or lower than threshold level 0 = Data word(s) in FIFO is higher than threshold level</p> <p>This bit is read only</p>
[17]	<b>TXOVF</b>	<p><b>Transmit FIFO overflow flag</b></p> <p>Write data to transmit FIFO when it is full and this bit set to 1</p> <p>1 = Overflow 0 = No overflow</p> <p>Software can write 1 to clear this bit to zero</p>
[16]	<b>TXUDF</b>	<p><b>Transmit FIFO underflow flag</b></p> <p>When transmit FIFO is empty and shift logic hardware read data from data FIFO causes this set to 1.</p> <p>1 = Underflow 0 = No underflow</p> <p>Software can write 1 to clear this bit to zero</p>
[15:13]	<b>Reserved</b>	Reserved



Bits	Descriptions	
[12]	<b>RXEMPTY</b>	<p><b>Receive FIFO empty</b></p> <p>This bit reflects data words number in receive FIFO is zero</p> <p>1 = Empty</p> <p>0 = Not empty</p> <p>This bit is read only.</p>
[11]	<b>RXFULL</b>	<p><b>Receive FIFO full</b></p> <p>This bit reflect data words number in receive FIFO is 8</p> <p>1 = Full</p> <p>0 = Not full</p> <p>This bit is read only.</p>
[10]	<b>RXTHF</b>	<p><b>Receive FIFO threshold flag</b></p> <p>When data word(s) in receive FIFO is equal or higher than threshold value set in RXTH[2:0] the RXTHF bit becomes to 1. It keeps at 1 till RXFIFO_LEVEL[3:0] less than RXTH[1:0] after software read RXFIFO register.</p> <p>1 = Data word(s) in FIFO is equal or higher than threshold level</p> <p>0 = Data word(s) in FIFO is lower than threshold level</p> <p>This bit is read only</p>
[9]	<b>RXOVF</b>	<p><b>Receive FIFO overflow flag</b></p> <p>When receive FIFO is full and receive hardware attempt write to data into receive FIFO then this bit is set to 1, data in 1st buffer is overwrote.</p> <p>1 = Overflow occur</p> <p>0 = No overflow occur</p> <p>Software can write 1 to clear this bit to zero</p>
[8]	<b>RXUDF</b>	<p><b>Receive FIFO underflow flag</b></p> <p>Read receive FIFO when it is empty, this bit set to 1 indicate underflow occur.</p> <p>1 = Underflow occur</p> <p>0 = No underflow occur</p> <p>Software can write 1 to clear this bit to zero</p>
[7:4]	<b>Reserved</b>	Reserved
[3]	<b>RIGHT</b>	<p><b>Right channel</b></p> <p>This bit indicate current transmit data is belong to right channel</p> <p>1 = Right channel</p> <p>0 = Left channel</p> <p>This bit is read only</p>
[2]	<b>I2STXINT</b>	<p><b>I<sup>2</sup>S transmit interrupt</b></p> <p>1 = Transmit interrupt</p> <p>0 = No transmit interrupt</p> <p>This bit is read only</p>



Bits	Descriptions	
[1]	I2SRXINT	<b>I<sup>2</sup>S receive interrupt</b> 1 = Receive interrupt 0 = No receive interrupt This bit is read only
[0]	I2SINT	<b>I<sup>2</sup>S Interrupt flag</b> 1 = I <sup>2</sup> S interrupt 0 = No I <sup>2</sup> S interrupt It is wire-OR of I2STXINT and I2SRXINT bits. This bit is read only.

## I<sup>2</sup>S Transmit FIFO (I2STXFIFO)

Register	Offset	R/W	Description	Reset Value
I2STXFIFO	I2S_BA+0x10	W	I <sup>2</sup> S Transmit FIFO	0x0000_0000

31	30	29	28	27	26	25	24
TXFIFO[31:24]							
23	22	21	20	19	18	17	16
TXFIFO[23:16]							
15	14	13	12	11	10	9	8
TXFIFO[15:8]							
7	6	5	4	3	2	1	0
TXFIFO[7:0]							

Bits	Descriptions	
[31:0]	TXFIFO	<b>Transmit FIFO register</b> I <sup>2</sup> S contains 8 words (8x32 bit) data buffer for data transmit. Write data to this register to prepare data for transmit. The remain word number is indicated by TX_LEVEL[3:0] in I2SSTATUS





## I<sup>2</sup>S Receive FIFO (I2SRXFIFO)

Register	Offset	R/W	Description	Reset Value
I2SRXFIFO	I2S_BA+0x14	R	I <sup>2</sup> S Receive FIFO	0x0000_0000

31	30	29	28	27	26	25	24
RXFIFO[31:24]							
23	22	21	20	19	18	17	16
RXFIFO[23:16]							
15	14	13	12	11	10	9	8
RXFIFO[15:8]							
7	6	5	4	3	2	1	0
RXFIFO[7:0]							

Bits	Descriptions	
[31:0]	<b>RXFIFO</b>	<p><b>Receive FIFO register</b></p> <p>I<sup>2</sup>S contains 8 words (8x32 bit) data buffer for data receive. Read this register to get data in FIFO. The remaining data word number is indicated by RX_LEVEL[3:0] in I2SSTATUS register.</p>

## 5.15 Analog-to-Digital Converter (ADC)

### 5.15.1 Overview

NuMicro™ NUC100 Series contains one 12-bit successive approximation analog-to-digital converters (SAR A/D converter) with 8 input channels. The A/D converter supports three operation modes: single, single-cycle scan and continuous scan mode. The A/D converters can be started by software and external STADC pin.

### 5.15.2 Features

- Analog input voltage range:  $0 \sim V_{REF}$
- 12-bit resolution and 10-bit accuracy is guaranteed
- Up to 8 single-end analog input channels or 4 differential analog input channels
- Maximum ADC clock frequency is 16 MHz
- Up to 600K SPS conversion rate
- Three operating modes
  - Single mode: A/D conversion is performed one time on a specified channel
  - Single-cycle scan mode: A/D conversion is performed one cycle on all specified channels with the sequence from the lowest numbered channel to the highest numbered channel
  - Continuous scan mode: A/D converter continuously performs Single-cycle scan mode until software stops A/D conversion
- An A/D conversion can be started by
  - Software write 1 to ADST bit
  - External pin STADC
- Conversion results are held in data registers for each channel with valid and overrun indicators
- Conversion result can be compared with specify value and user can select whether to generate an interrupt when conversion result is equal to the compare register setting
- Channel 7 supports 3 input sources: external analog voltage, internal bandgap voltage, and internal temperature sensor output
- Support Self-calibration to minimize conversion error

5.15.3 Block Diagram

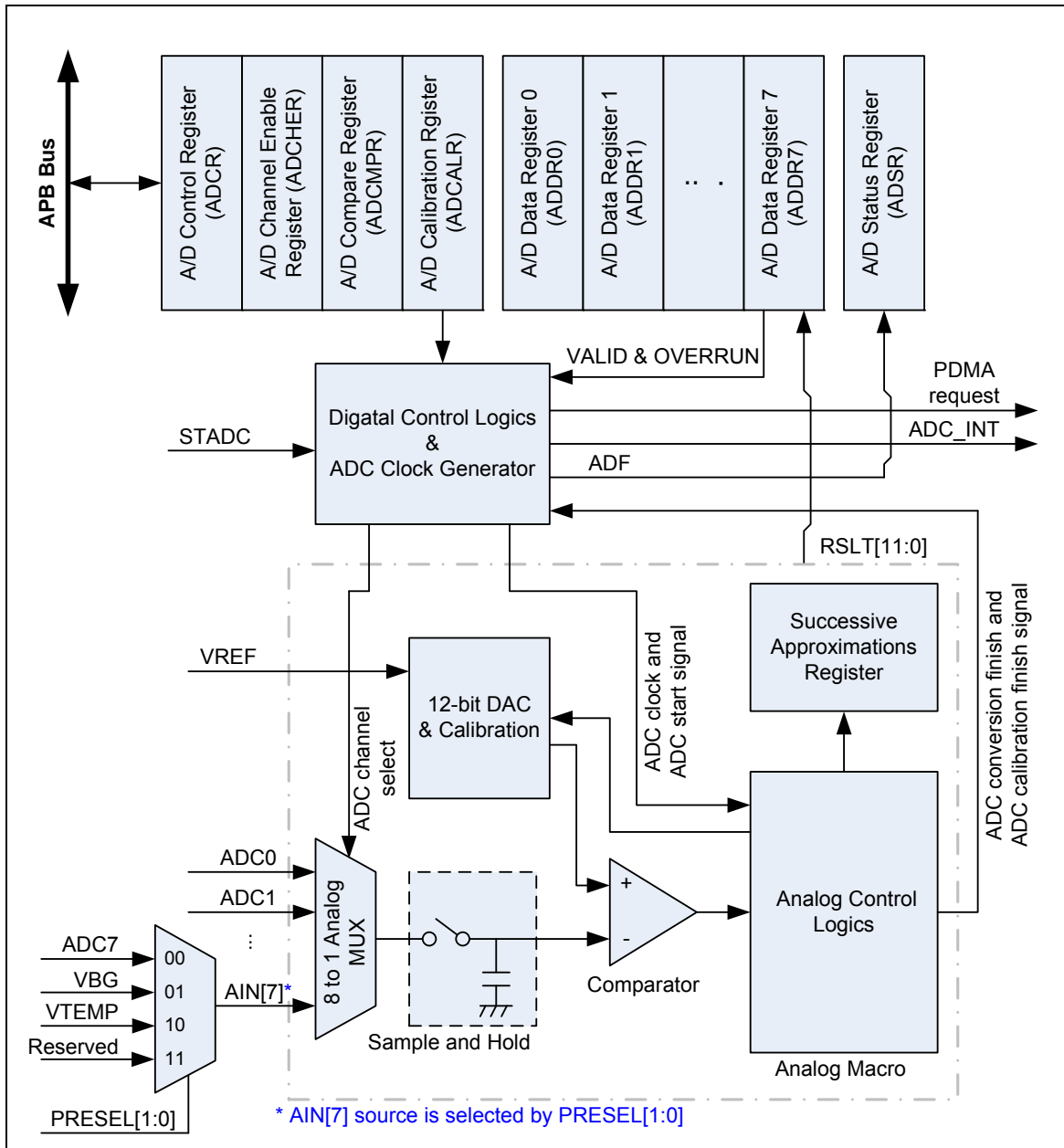

Figure 5-86 ADC Controller Block Diagram

**5.15.4 Functional Description**

The A/D converter operates by successive approximation with 12-bit resolution. This A/D converter equips with self calibration function to minimize conversion error, user can write 1 to CAL\_EN bit in ADCALR register to enable calibration function, while internal calibration is finished the CAL\_DONE bit will be set to 1 by hardware. The ADC has three operation modes: single mode, single-cycle scan mode and continuous scan mode. When changing the operating mode or analog input channel, in order to prevent incorrect operation, software must clear ADST bit to 0 in ADCR register.

**5.15.4.1 Self-Calibration**

When chip power on or switch ADC input type between single-end input and differential input, it needs to do ADC self calibration to minimize the conversion error. User can write 1 to CAL\_EN bit of ADCALR register to start the self calibration. It needs 127 ADC clocks to complete the calibration and the CAL\_DONE bit will be set to 1 by hardware. The detail timing is shown as below:

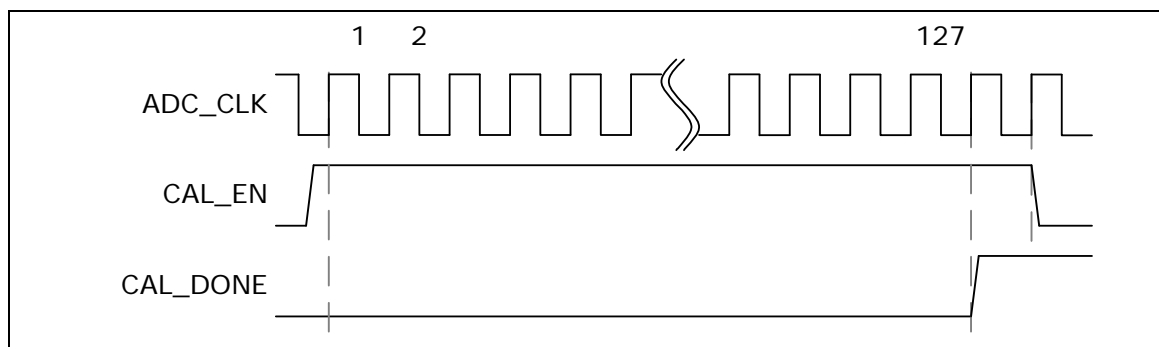

Figure 5-87 ADC Converter Self-Calibration Timing Diagram

**5.15.4.2 ADC Clock Generator**

The maximum sampling rate is up to 600K SPS. The ADC engine has three clock sources selected by 2-bit ADC\_S (CLKSEL1[3:2]), the ADC clock frequency is divided by an 8-bit prescaler with the formula:

$$\text{The ADC clock frequency} = (\text{ADC clock source frequency}) / (\text{ADC\_N} + 1);$$

where the 8-bit ADC\_N is located in register CLKDIV[23:16].

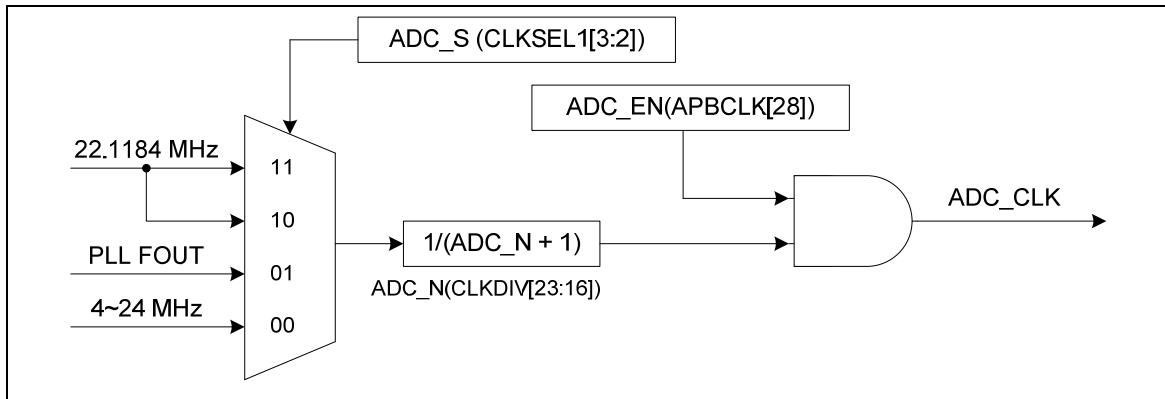

Figure 5-88 ADC Clock Control

5.15.4.3 Single Mode

In single mode, A/D conversion is performed only once on the specified single channel. The operations are as follows:

1. A/D conversion will be started when the ADST bit of ADCR is set to 1 by software or external trigger input.
2. When A/D conversion is finished, the result is stored in the A/D data register corresponding to the channel.
3. The ADF bit of ADSR register will be set to 1. If the ADIE bit of ADCR register is set to 1, the ADC interrupt will be asserted.
4. The ADST bit remains 1 during A/D conversion. When A/D conversion ends, the ADST bit is automatically cleared to 0 and the A/D converter enters idle state. Note that, after clearing the ADST bit, the ADST bit must be kept at 0 at least one ADC clock period before setting it to 1 again. If not, the A/D converter may not work.

Note: If software enables more than one channel in single mode, the channel with the lowest number will be selected and the other enabled channels will be ignored.

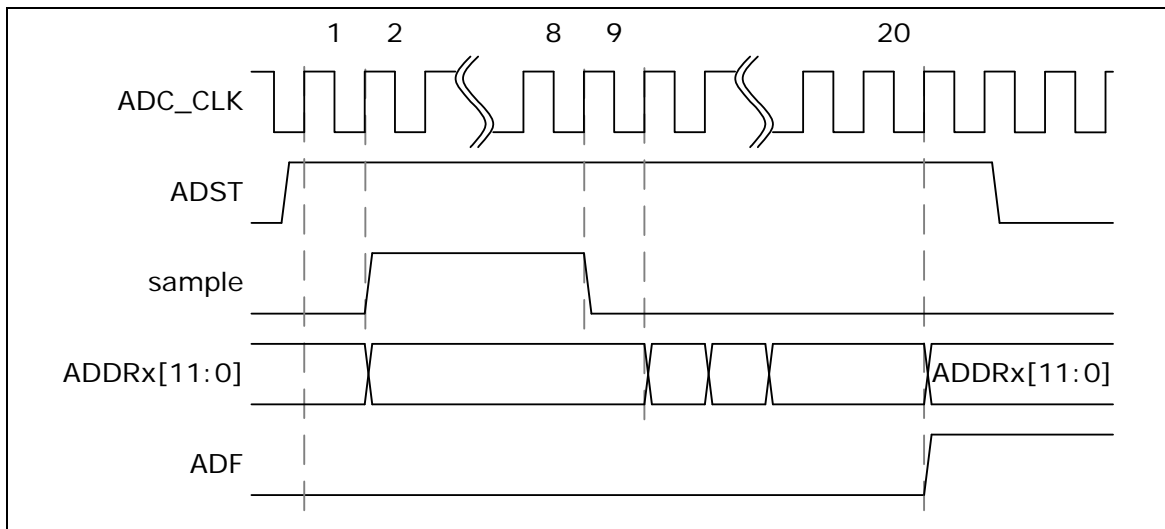

Figure 5-89 Single Mode Conversion Timing Diagram

## 5.15.4.4 Single-Cycle Scan Mode

In single-cycle scan mode, A/D conversion will sample and convert the specified channels once in the sequence from the lowest number enabled channel to the highest number enabled channel.

1. When the ADST bit of ADCR is set to 1 by software or external trigger input, A/D conversion starts on the channel with the lowest number.
2. When A/D conversion for each enabled channel is completed, the result is sequentially transferred to the A/D data register corresponding to each channel.
3. When the conversions of all the enabled channels are completed, the ADF bit in ADSR is set to 1. If the ADC interrupt function is enabled, the ADC interrupt occurs.
4. After A/D conversion ends, the ADST bit is automatically cleared to 0 and the A/D converter enters idle state. If ADST is cleared to 0 before all enabled ADC channels conversion done, ADC controller will finish current conversion and the result of the lowest enabled ADC channel will become unpredictable. Note that, after clearing the ADST bit to 0, the ADST bit must be kept at 0 at least one ADC clock period before setting it to 1 again. If not, the A/D converter may not work.

An example timing diagram for single-cycle scan on enabled channels (0, 2, 3 and 7) is shown as below:

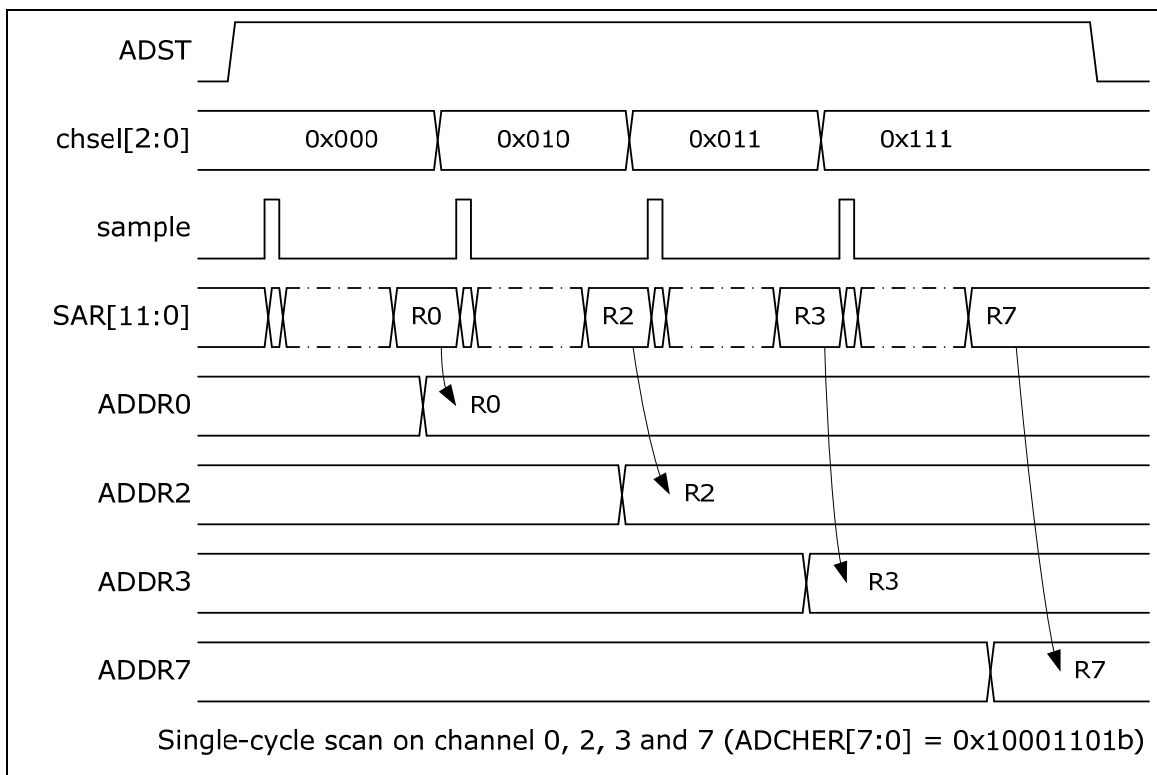

Figure 5-90 Single-Cycle Scan on Enabled Channels Timing Diagram

## 5.15.4.5 Continuous Scan Mode

In continuous scan mode, A/D conversion is performed sequentially on the specified channels that enabled by CHEN bits in ADCHER register (maximum 8 channels for ADC). The operations are as follows:

1. When the ADST bit in ADCR is set to 1 by software or external trigger input, A/D conversion starts on the channel with the lowest number.
2. When A/D conversion for each enabled channel is completed, the result of each enabled channel is stored in the A/D data register corresponding to each enabled channel.
3. When A/D converter completes the conversions of all enabled channels sequentially, the ADF bit (ADSR[0]) will be set to 1. If the ADC interrupt function is enabled, the ADC interrupt occurs. The conversion of the enabled channel with the lowest number will start again if software has not cleared the ADST bit.
4. As long as the ADST bit remains at 1, the step 2 ~ 3 will be repeated. When ADST is cleared to 0, ADC controller will finish current conversion and the result of the lowest enabled ADC channel will become unpredictable.

An example timing diagram for continuous scan on enabled channels (0, 2, 3 and 7) is shown as below:

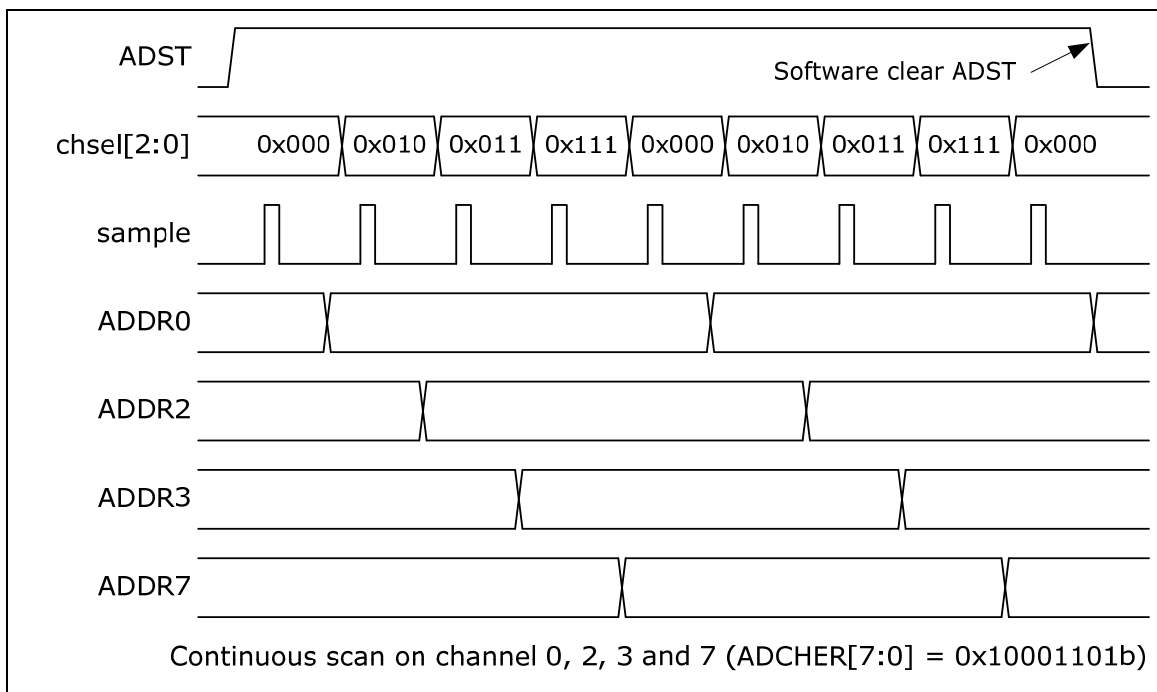

Figure 5-91 Continuous Scan on Enabled Channels Timing Diagram

## 5.15.4.6 External trigger Input Sampling and A/D Conversion Time

In single-cycle scan mode, A/D conversion can be triggered by external pin request. When the ADCR.TRGEN is set to high to enable ADC external trigger function, setting the TRGS[1:0] bits to 00b is to select external trigger input from the STADC pin. Software can set TRGCOND[1:0] to select trigger condition is falling/rising edge or low/high level. If level trigger condition is selected, the STADC pin must be kept at defined state at least 8 PCLKs. The ADST bit will be set to 1 at the 9th PCLK and start to conversion. Conversion is continuous if external trigger input is kept at active state in level trigger mode. It is stopped only when external condition trigger condition disappears. If edge trigger condition is selected, the high and low state must be kept at least 4 PCLKs. Pulse that is shorter than this specification will be ignored.

## 5.15.4.7 Conversion Result Monitor by Compare Function

ADC controller provide two sets of compare register ADCMPR0 and ADCMPR1, to monitor maximum two specified channels conversion result from A/D conversion controller, refer to Figure 5-92. Software can select which channel to be monitored by set CMPCH(ADCMPRx[5:0]) and CMPCOND bit is used to check conversion result is less than specify value or greater than (equal to) value specified in CMPD[11:0]. When the conversion of the channel specified by CMPCH is completed, the comparing action will be triggered one time automatically. When the compare result meets the setting, compare match counter will increase 1, otherwise, the compare match counter will be clear to 0. When counter value reach the setting of (CMPMATCNT+1) then CMPF bit will be set to 1, if CMPIE bit is set then an ADC\_INT interrupt request is generated. Software can use it to monitor the external analog input pin voltage transition in scan mode without imposing a load on software. Detail logics diagram is shown as below:

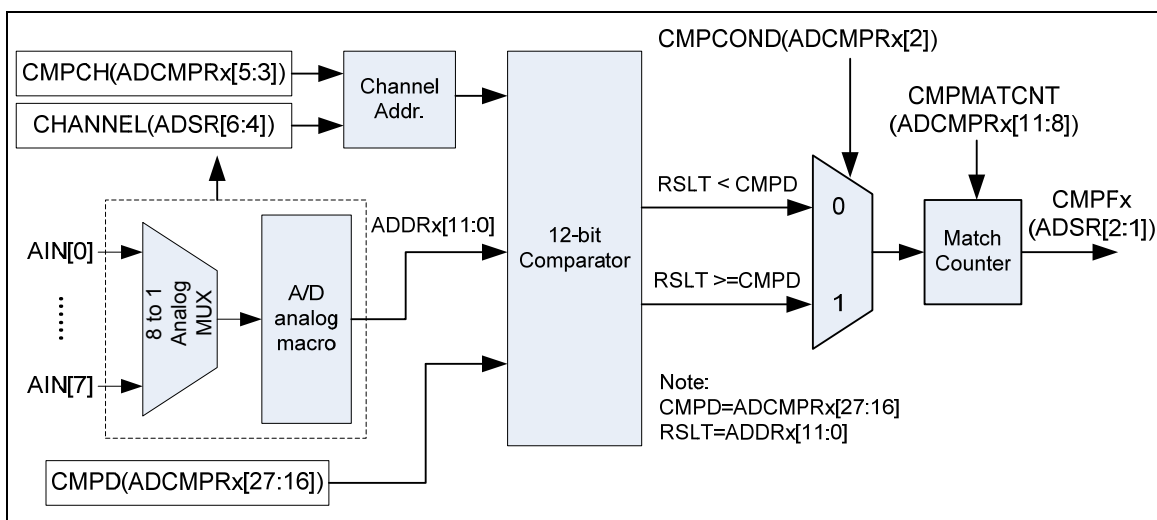

Figure 5-92 A/D Conversion Result Monitor Logics Diagram



#### 5.15.4.8 Interrupt Sources

There are three interrupt sources of ADC interrupt. When an ADC operation mode finishes its conversion, the A/D conversion end flag, ADF, will be set to 1. The CMPF0 and CMPF1 are the compare flags of compare function. When the conversion result meets the settings of ADCMPR0/1, the corresponding flag will be set to 1. When one of the flags, ADF, CMPF0 and CMPF1, is set to 1 and the corresponding interrupt enable bit, ADIE of ADCR and CMPIE of ADCMPR0/1, is set to 1, the ADC interrupt will be asserted. Software can clear the flag to revoke the interrupt request.

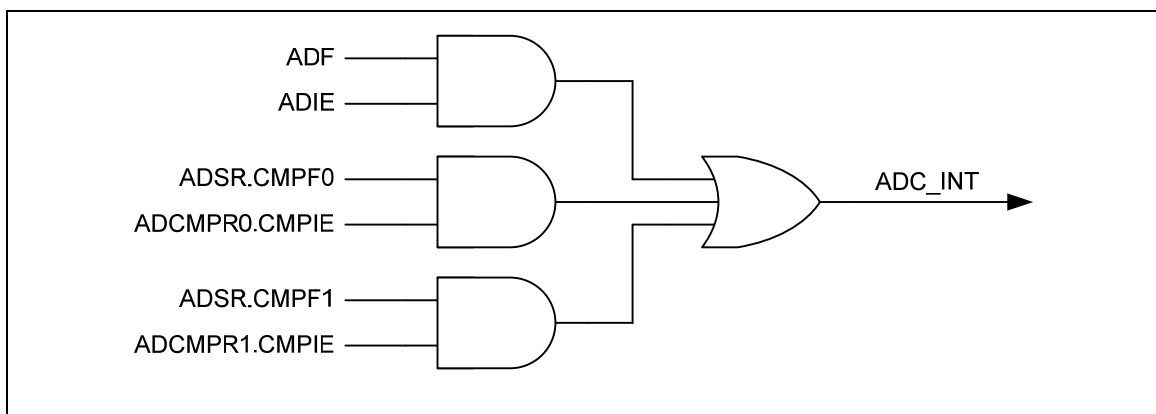

Figure 5-93 A/D Controller Interrupt

#### 5.15.4.9 Peripheral DMA Request

When A/D conversion is finished, the conversion result will be loaded into ADDR register and VALID bit will be set to 1. If the PTEN bit of ADCR is set, ADC controller will generate a request to PDMA. User can use PDMA to transfer the conversion results to a user-specified memory space without CPU's intervention. The source address of PDMA operation is fixed at ADPDMA, no matter what channels was selected. When PDMA is transferring the conversion result, ADC will continue converting the next selected channel if the operation mode of ADC is single scan mode or continuous scan mode. User can monitor current PDMA transfer data through reading ADPDMA register. If ADC completes the conversion of a selected channel and the last conversion result of the same channel has not been transferred by PDMA, OVERUN bit of the corresponding channel will be set and the last ADC conversion result will be overwrite by the new ADC conversion result. PDMA will transfer the latest data of selected channels to the user-specified destination address.



### 5.15.5 Register Map

R: read only, W: write only, R/W: both read and write

Register	Offset	R/W	Description	Reset Value
<b>ADC_BA = 0x400E_0000</b>				
<b>ADDR0</b>	ADC_BA+0x00	R	A/D Data Register 0	0x0000_0000
<b>ADDR1</b>	ADC_BA+0x04	R	A/D Data Register 1	0x0000_0000
<b>ADDR2</b>	ADC_BA+0x08	R	A/D Data Register 2	0x0000_0000
<b>ADDR3</b>	ADC_BA+0x0C	R	A/D Data Register 3	0x0000_0000
<b>ADDR4</b>	ADC_BA+0x10	R	A/D Data Register 4	0x0000_0000
<b>ADDR5</b>	ADC_BA+0x14	R	A/D Data Register 5	0x0000_0000
<b>ADDR6</b>	ADC_BA+0x18	R	A/D Data Register 6	0x0000_0000
<b>ADDR7</b>	ADC_BA+0x1C	R	A/D Data Register 7	0x0000_0000
<b>ADCR</b>	ADC_BA+0x20	R/W	A/D Control Register	0x0000_0000
<b>ADCHER</b>	ADC_BA+0x24	R/W	A/D Channel Enable Register	0x0000_0000
<b>ADCMPR0</b>	ADC_BA+0x28	R/W	A/D Compare Register 0	0x0000_0000
<b>ADCMPR1</b>	ADC_BA+0x2C	R/W	A/D Compare Register 1	0x0000_0000
<b>ADSR</b>	ADC_BA+0x30	R/W	A/D Status Register	0x0000_0000
<b>ADCALR</b>	ADC_BA+0x34	R/W	A/D Calibration Register	0x0000_0000
<b>ADPDMA</b>	ADC_BA+0x40	R	ADC PDMA current transfer data	0x0000_0000



5.15.6 Register Description

**A/D Data Registers (ADDR0 ~ ADDR7)**

Register	Offset	R/W	Description	Reset Value
ADDR0	ADC_BA+0x00	R	A/D Data Register 0	0x0000_0000
ADDR1	ADC_BA+0x04	R	A/D Data Register 1	0x0000_0000
ADDR2	ADC_BA+0x08	R	A/D Data Register 2	0x0000_0000
ADDR3	ADC_BA+0x0C	R	A/D Data Register 3	0x0000_0000
ADDR4	ADC_BA+0x10	R	A/D Data Register 4	0x0000_0000
ADDR5	ADC_BA+0x14	R	A/D Data Register 5	0x0000_0000
ADDR6	ADC_BA+0x18	R	A/D Data Register 6	0x0000_0000
ADDR7	ADC_BA+0x1C	R	A/D Data Register 7	0x0000_0000

31	30	29	28	27	26	25	24
Reserved							
23	22	21	20	19	18	17	16
Reserved						VALID	OVERRUN
15	14	13	12	11	10	9	8
RSLT [15:8]							
7	6	5	4	3	2	1	0
RSLT[7:0]							

Bits	Descriptions	
[31:18]	Reserved	Reserved
[17]	VALID	<p><b>Valid Flag</b></p> <p>1 = Data in RSLT[15:0] bits is valid</p> <p>0 = Data in RSLT[15:0] bits is not valid</p> <p>This bit is set to 1 when corresponding channel analog input conversion is completed and cleared by hardware after ADDR register is read.</p> <p>This is a read only bit</p>



Bits	Descriptions	
[16]	<b>OVERRUN</b>	<p><b>Over Run Flag</b></p> <p>1 = Data in RSLT[15:0] is overwrite                      0 = Data in RSLT[15:0] is recent conversion result</p> <p>If converted data in RSLT[15:0] has not been read before new conversion result is loaded to this register, OVERRUN is set to 1 and previous conversion result is gone. It is cleared by hardware after ADDR register is read.</p> <p>This is a read only bit</p>
[15:0]	<b>RSLT</b>	<p><b>A/D Conversion Result</b></p> <p>This field contains conversion result of ADC.</p> <p>For NuMicro™ NUC100/NUC120 Medium density, RSLT[15:12] always read as 0.</p> <p>The following description is only support in NuMicro™ NUC100/NUC120 Low Density:</p> <p>When DMOF bit (ADCR[31]) set to 0, 12-bit ADC conversion result with unsigned format will be filled in RSLT[11:0] and zero will be filled in RSLT[15:12].</p> <p>When DMOF bit (ADCR[31]) set to 1, 12-bit ADC conversion result with 2's complement format will be filled in RSLT[11:0] and signed bits to will be filled in RSLT[15:12].</p>

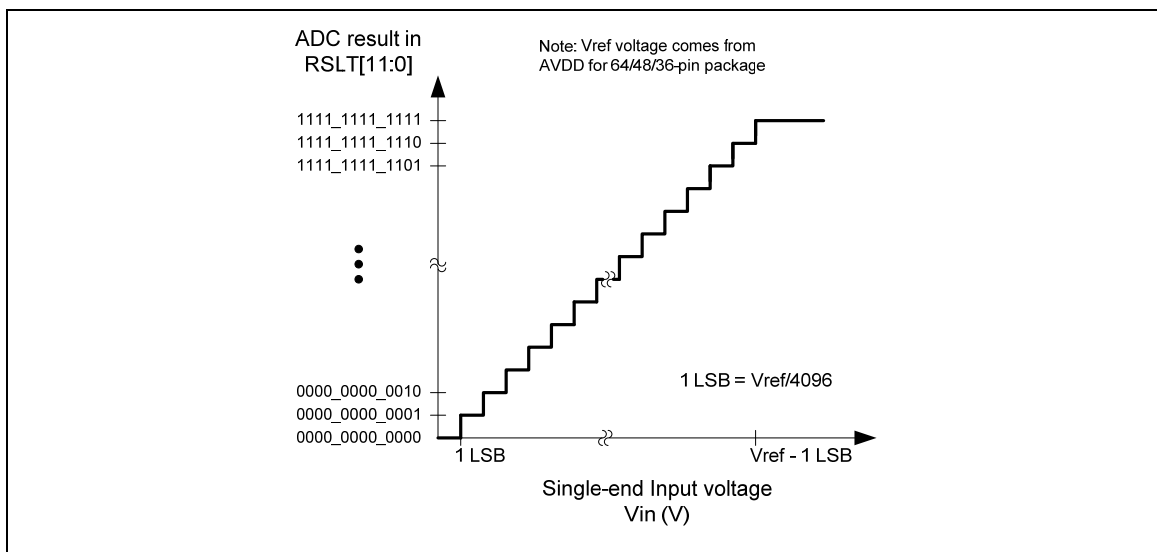

Figure 5-94 ADC single-end input conversion voltage and conversion result mapping diagram

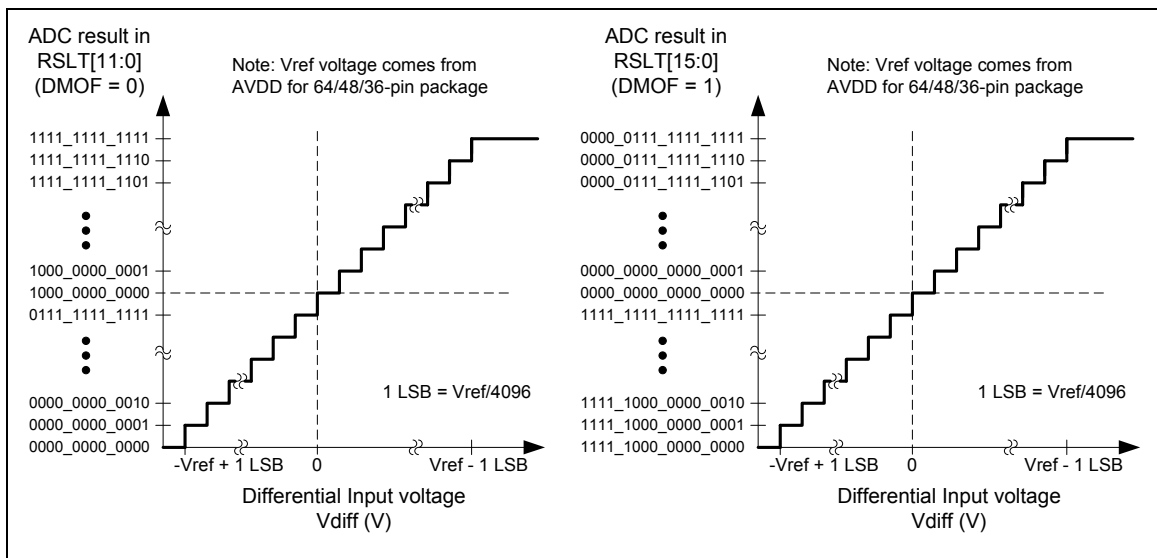

Figure 5-95 ADC differential input conversion voltage and conversion result mapping diagram



## A/D Control Register (ADCR)

Register	Offset	R/W	Description	Reset Value
ADCR	ADC_BA+0x20	R/W	ADC Control Register	0x0000_0000

31	30	29	28	27	26	25	24
DMOF		Reserved					
23	22	21	20	19	18	17	16
Reserved							
15	14	13	12	11	10	9	8
Reserved				ADST	DIFFEN	PTEN	TRGEN
7	6	5	4	3	2	1	0
TRGCOND		TRGS		ADMD		ADIE	ADEN

Bits	Descriptions	
[31]	DMOF	<p><b>A/D differential input Mode Output Format</b> (This bit is only support in NuMicro™ NUC100/NUC120 Low Density)</p> <p>1 = A/D Conversion result will be filled in RSLT at ADDR<sub>x</sub> registers with 2's complement format.</p> <p>0 = A/D Conversion result will be filled in RSLT at ADDR<sub>x</sub> registers with unsigned format.</p>
[30:12]	Reserved	Reserved
[11]	ADST	<p><b>A/D Conversion Start</b></p> <p>1 = Conversion start</p> <p>0 = Conversion stopped and A/D converter enter idle state</p> <p>ADST bit can be set to 1 from two sources: software and external pin STADC. ADST will be cleared to 0 by hardware automatically at the ends of single mode and single-cycle scan mode. In continuous scan mode, A/D conversion is continuously performed until software write 0 to this bit or chip reset.</p>



Bits	Descriptions																		
[10]	<b>DIFFEN</b>	<p><b>Differential Input Mode Enable</b>                      1 = Differential analog input mode                      0 = Single-end analog input mode</p> <table border="1" style="width: 100%; border-collapse: collapse;"> <thead> <tr> <th rowspan="2" style="text-align: center;">Differential input paired channel</th> <th colspan="2" style="text-align: center;">ADC analog input</th> </tr> <tr> <th style="text-align: center;"><math>V_{plus}</math></th> <th style="text-align: center;"><math>V_{minus}</math></th> </tr> </thead> <tbody> <tr> <td style="text-align: center;">0</td> <td style="text-align: center;">ADC0</td> <td style="text-align: center;">ADC1</td> </tr> <tr> <td style="text-align: center;">1</td> <td style="text-align: center;">ADC2</td> <td style="text-align: center;">ADC3</td> </tr> <tr> <td style="text-align: center;">2</td> <td style="text-align: center;">ADC4</td> <td style="text-align: center;">ADC5</td> </tr> <tr> <td style="text-align: center;">3</td> <td style="text-align: center;">ADC6</td> <td style="text-align: center;">ADC7</td> </tr> </tbody> </table> <p>Differential input voltage (<math>V_{diff}</math>) = <math>V_{plus} - V_{minus}</math>, where <math>V_{plus}</math> is the analog input; <math>V_{minus}</math> is the inverted analog input.</p> <p>In differential input mode, only the even number of the two corresponding channels needs to be enabled in ADCHER. The conversion result will be placed to the corresponding data register of the enabled channel.</p>	Differential input paired channel	ADC analog input		$V_{plus}$	$V_{minus}$	0	ADC0	ADC1	1	ADC2	ADC3	2	ADC4	ADC5	3	ADC6	ADC7
Differential input paired channel	ADC analog input																		
	$V_{plus}$	$V_{minus}$																	
0	ADC0	ADC1																	
1	ADC2	ADC3																	
2	ADC4	ADC5																	
3	ADC6	ADC7																	
[9]	<b>PTEN</b>	<p><b>PDMA Transfer Enable</b>                      1 = Enable PDMA data transfer in ADDR 0~7                      0 = Disable PDMA data transfer</p> <p>When A/D conversion is completed, the converted data is loaded into ADDR 0~7, software can enable this bit to generate a PDMA data transfer request.</p> <p>When PTEN=1, software must set ADIE=0 to disable interrupt.</p>																	
[8]	<b>TRGEN</b>	<p><b>External Trigger Enable</b>                      Enable or disable triggering of A/D conversion by external STADC pin.</p> <p>1= Enable                      0= Disable</p> <p>ADC external trigger function is only supported in single-cycle scan mode.</p>																	
[7:6]	<b>TRGCOND</b>	<p><b>External Trigger Condition</b>                      These two bits decide external pin STADC trigger event is level or edge. The signal must be kept at stable state at least 8 PCLKs for level trigger and 4 PCLKs at high and low state for edge trigger.</p> <p>00 = Low level                      01 = High level                      10 = Falling edge                      11 = Rising edge</p>																	
[5:4]	<b>TRGS</b>	<p><b>Hardware Trigger Source</b>                      00 = A/D conversion is started by external STADC pin.                      Others = Reserved</p> <p>Software should disable TRGEN and ADST before change TRGS.</p> <p>In hardware trigger mode, the ADST bit is set by the external trigger from STADC.</p>																	



Bits	Descriptions	
[3:2]	<b>ADMD</b>	<p><b>A/D Converter Operation Mode</b></p> <p>00 = Single conversion                      01 = Reserved                      10 = Single-cycle scan                      11 = Continuous scan</p> <p>When changing the operation mode, software should disable ADST bit firstly.</p>
[1]	<b>ADIE</b>	<p><b>A/D Interrupt Enable</b></p> <p>1 = Enable A/D interrupt function                      0 = Disable A/D interrupt function</p> <p>A/D conversion end interrupt request is generated if ADIE bit is set to 1.</p>
[0]	<b>ADEN</b>	<p><b>A/D Converter Enable</b></p> <p>1 = Enable                      0 = Disable</p> <p>Before starting A/D conversion function, this bit should be set to 1. Clear it to 0 to disable A/D converter analog circuit for saving power consumption.</p>





**A/D Channel Enable Register (ADCHER)**

Register	Offset	R/W	Description	Reset Value
ADCHER	ADC_BA+0x24	R/W	A/D Channel Enable	0x0000_0000

31	30	29	28	27	26	25	24
Reserved							
23	22	21	20	19	18	17	16
Reserved							
15	14	13	12	11	10	9	8
Reserved						PRESEL[1:0]	
7	6	5	4	3	2	1	0
CHEN7	CHEN6	CHEN5	CHEN4	CHEN3	CHEN2	CHEN1	CHEN0

Bits	Descriptions	
[31:10]	Reserved	Reserved
[9:8]	PRESEL	<b>Analog Input Channel 7 select</b> 00 = External analog input 01 = Internal bandgap voltage 10 = Internal temperature sensor 11 = Reserved Note: When software select the bandgap voltage as the analog input source of ADC channel 7, ADC clock rate needs to be limited to lower than 300 KHz.
[7]	CHEN7	<b>Analog Input Channel 7 Enable</b> 1 = Enable 0 = Disable
[6]	CHEN6	<b>Analog Input Channel 6 Enable</b> 1 = Enable 0 = Disable
[5]	CHEN5	<b>Analog Input Channel 5 Enable</b> 1 = Enable 0 = Disable
[4]	CHEN4	<b>Analog Input Channel 4 Enable</b> 1 = Enable 0 = Disable



Bits	Descriptions	
[3]	<b>CHEN3</b>	<b>Analog Input Channel 3 Enable</b> 1 = Enable 0 = Disable
[2]	<b>CHEN2</b>	<b>Analog Input Channel 2 Enable</b> 1 = Enable 0 = Disable
[1]	<b>CHEN1</b>	<b>Analog Input Channel 1 Enable</b> 1 = Enable 0 = Disable
[0]	<b>CHEN0</b>	<b>Analog Input Channel 0 Enable</b> 1 = Enable 0 = Disable



## A/D Compare Register 0/1 (ADCMR0/1)

Register	Offset	R/W	Description	Reset Value
ADCMR0	ADC_BA+0x28	R/W	A/D Compare Register 0	0x0000_0000
ADCMR1	ADC_BA+0x2C	R/W	A/D Compare Register 1	0x0000_0000

31	30	29	28	27	26	25	24
Reserved				CMPD[11:8]			
23	22	21	20	19	18	17	16
CMPD[7:0]							
15	14	13	12	11	10	9	8
Reserved				CMPMATCNT			
7	6	5	4	3	2	1	0
Reserved		CMPCH			CMPCOND	CMPIE	CMPEN

Bits	Descriptions	
[31:28]	Reserved	Reserved
[27:16]	CMPD	<p><b>Comparison Data</b></p> <p>The 12-bit data is used to compare with conversion result of specified channel.</p> <p>The following description is only support in NuMicro™ NUC100/NUC120 Low Density:</p> <p>When DMOF bit is set to 0, ADC comparator compares CMPD with conversion result with unsigned format. CMPD should be filled in unsigned format.</p> <p>When DMOF bit is set to 1, ADC comparator compares CMPD with conversion result with 2's complement format. CMPD should be filled in 2's complement format.</p>
[15:12]	Reserved	Reserved
[11:8]	CMPMATCNT	<p><b>Compare Match Count</b></p> <p>When the specified A/D channel analog conversion result matches the compare condition defined by CMPCOND[2], the internal match counter will increase 1. When the internal counter reaches the value to (CMPMATCNT +1), the CMPFx bit will be set.</p>
[7:6]	Reserved	Reserved



Bits	Descriptions	
[5:3]	<b>CMPCH</b>	<p><b>Compare Channel Selection</b></p> <p>000 = Channel 0 conversion result is selected to be compared                      001 = Channel 1 conversion result is selected to be compared                      010 = Channel 2 conversion result is selected to be compared                      011 = Channel 3 conversion result is selected to be compared                      100 = Channel 4 conversion result is selected to be compared                      101 = Channel 5 conversion result is selected to be compared                      110 = Channel 6 conversion result is selected to be compared                      111 = Channel 7 conversion result is selected to be compared</p>
[2]	<b>CMPCOND</b>	<p><b>Compare Condition</b></p> <p>1 = Set the compare condition as that when a 12-bit A/D conversion result is greater or equal to the 12-bit CMPD (ADCMPRx[27:16]), the internal match counter will increase one.                      0 = Set the compare condition as that when a 12-bit A/D conversion result is less than the 12-bit CMPD (ADCMPRx[27:16]), the internal match counter will increase one.                      Note: When the internal counter reaches the value to (CMPMATCNT +1), the CMPF<sub>x</sub> bit will be set.</p>
[1]	<b>CMPIE</b>	<p><b>Compare Interrupt Enable</b></p> <p>1 = Enable compare function interrupt                      0 = Disable compare function interrupt</p> <p>If the compare function is enabled and the compare condition matches the setting of CMPCOND and CMPMATCNT, CMPF bit will be asserted, in the meanwhile, if CMPIE is set to 1, a compare interrupt request is generated.</p>
[0]	<b>CMPEN</b>	<p><b>Compare Enable</b></p> <p>1 = Enable compare function                      0 = Disable compare function</p> <p>Set this bit to 1 to enable ADC controller to compare CMPD[11:0] with specified channel conversion result when converted data is loaded into ADDR register.</p>



## A/D Status Register (ADSR)

Register	Offset	R/W	Description	Reset Value
ADSR	ADC_BA+0x30	R/W	ADC Status Register	0x0000_0000

31	30	29	28	27	26	25	24
Reserved							
23	22	21	20	19	18	17	16
OVERRUN							
15	14	13	12	11	10	9	8
VALID							
7	6	5	4	3	2	1	0
Reserved	CHANNEL			BUSY	CMPF1	CMPF0	ADF

Bits	Descriptions	
[31:24]	Reserved	Reserved
[23:16]	OVERRUN	<p><b>Over Run flag</b></p> <p>It is a mirror to OVERRUN bit in ADDR<sub>x</sub></p> <p>It is read only.</p>
[15:8]	VALID	<p><b>Data Valid flag</b></p> <p>It is a mirror of VALID bit in ADDR<sub>x</sub></p> <p>It is read only.</p>
[7]	Reserved	Reserved
[6:4]	CHANNEL	<p><b>Current Conversion Channel</b></p> <p>This field reflects current conversion channel when BUSY=1. When BUSY=0, it shows number of the next converted channel.</p> <p>It is read only.</p>
[3]	BUSY	<p><b>BUSY/IDLE</b></p> <p>1 = A/D converter is busy at conversion.</p> <p>0 = A/D converter is in idle state.</p> <p>This bit is mirror of as ADST bit in ADCR.</p> <p>It is read only.</p>
[2]	CMPF1	<p><b>Compare Flag</b></p> <p>When the selected channel A/D conversion result meets setting condition in ADCMPR1 then this bit is set to 1. And it is cleared by writing 1 to self.</p> <p>1 = Conversion result in ADDR meets ADCMPR1 setting</p> <p>0 = Conversion result in ADDR does not meet ADCMPR1 setting</p>



Bits	Descriptions	
[1]	<b>CMPF0</b>	<p><b>Compare Flag</b></p> <p>When the selected channel A/D conversion result meets setting condition in ADCMPR0 then this bit is set to 1. And it is cleared by writing 1 to self.</p> <p>1 = Conversion result in ADDR meets ADCMPR0 setting                      0 = Conversion result in ADDR does not meet ADCMPR0 setting</p>
[0]	<b>ADF</b>	<p><b>A/D Conversion End Flag</b></p> <p>A status flag that indicates the end of A/D conversion.</p> <p>ADF is set to 1 at these two conditions:</p> <ol style="list-style-type: none"> <li>1. When A/D conversion ends in single mode</li> <li>2. When A/D conversion ends on all specified channels in scan mode</li> </ol> <p>This flag can be cleared by writing 1 to self.</p>



## A/D Calibration Register (ADCALR)

Register	Offset	R/W	Description	Reset Value
ADCALR	ADC_BA+0x34	R/W	A/D Calibration Register	0x0000_0000

31	30	29	28	27	26	25	24
Reserved							
23	22	21	20	19	18	17	16
Reserved							
15	14	13	12	11	10	9	8
Reserved							
7	6	5	4	3	2	1	0
Reserved						CALDONE	CALEN

Bits	Descriptions	
[31:2]	Reserved	Reserved
[1]	CALDONE	<p><b>Calibration is Done</b></p> <p>1 = A/D converter self calibration is done</p> <p>0 = A/D converter has not been calibrated or calibration is in progress if CALEN bit is set.</p> <p>When 0 is written to CALEN bit, CALDONE bit is cleared by hardware immediately. It is a read only bit.</p>
[0]	CALEN	<p><b>Self Calibration Enable</b></p> <p>1 = Enable self calibration</p> <p>0 = Disable self calibration</p> <p>Software can set this bit to 1 to enable A/D converter to do self calibration function. It needs 127 ADC clocks to complete calibration. This bit must be kept at 1 after CALDONE asserted. Clearing this bit will disable self calibration function.</p>



### A/D PDMA current transfer data Register (ADPDMA)

Register	Offset	R/W	Description	Reset Value
ADPDMA	ADC_BA+0x40	R	A/D PDMA current transfer data Register	0x0000_0000

31	30	29	28	27	26	25	24
Reserved							
23	22	21	20	19	18	17	16
Reserved							
15	14	13	12	11	10	9	8
Reserved				AD_PDMA[11:8]			
7	6	5	4	3	2	1	0
AD_PDMA[7:0]							

Bits	Descriptions	
[31:12]	Reserved	Reserved
[11:0]	AD_PDMA	<b>ADC PDMA current transfer data register</b> When PDMA transferring, read this register can monitor current PDMA transfer data. This is a read only register.



## 5.16 Analog Comparator (CMP)

### 5.16.1 Overview

NuMicro™ NUC100 Series contains two comparators. The comparators can be used in a number of different configurations. The comparator output is a logical one when positive input greater than negative input, otherwise the output is a zero. Each comparator can be configured to cause an interrupt when the comparator output value changes. The block diagram is shown in Figure 5-96.

### 5.16.2 Features

- Analog input voltage range: 0~5.0 V
- Hysteresis function supported
- Two analog comparators with optional internal reference voltage input at negative end
- One interrupt vector for both comparators

### 5.16.3 Block Diagram

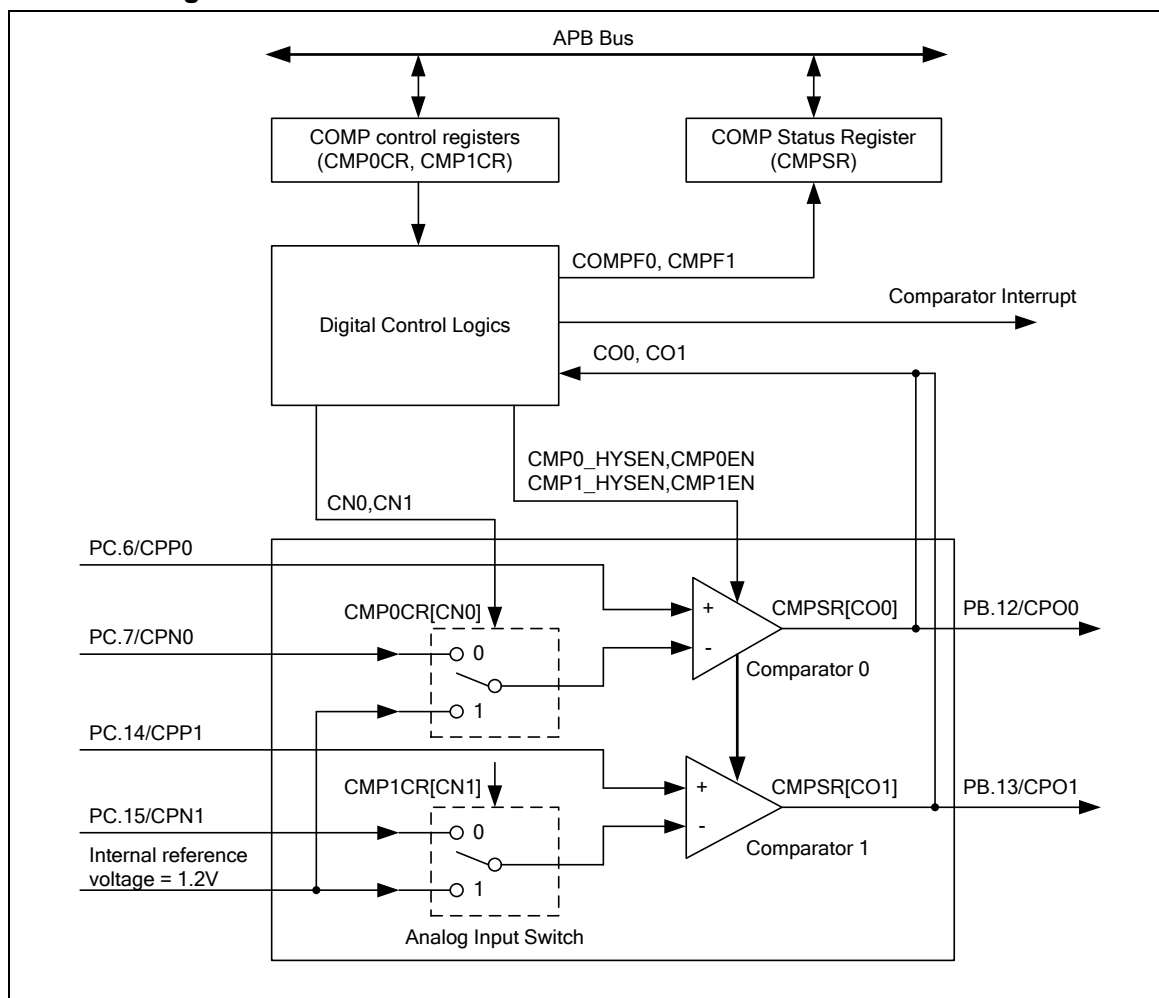

Figure 5-96 Analog Comparator Block Diagram

### 5.16.4 Functional Description

#### 5.16.4.1 Interrupt Sources

The output of comparators are sampled by PCLK and reflected at CO1 and CO2 of CMPSR register. If CMP0IE/CMP1IE of CMP0CR/CMP1CR is set to 1, the comparator interrupt will be enabled. As the output state of comparator is changed, the comparator interrupt will be asserted and the corresponding flag, CMPF0 or CMPF1, will be set. Software can clear the flag to 0 by writing 1 to it.

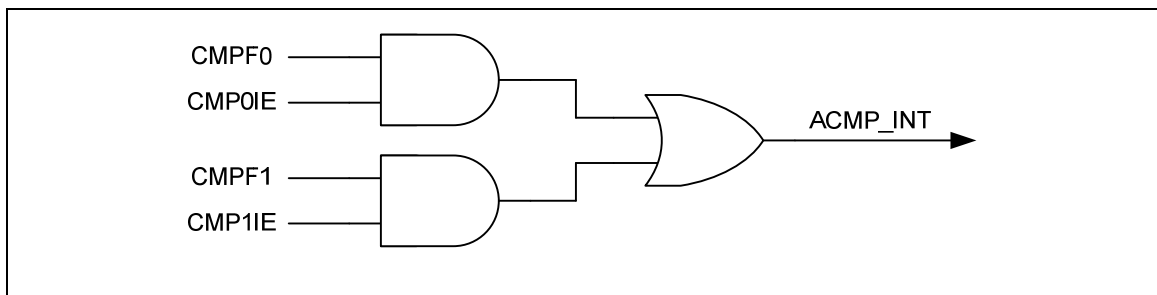

Figure 5-97 Comparator Controller Interrupt Sources



### 5.16.5 Register Map

R: read only, W: write only, R/W: both read and write

Register	Offset	R/W	Description	Reset Value
<b>CMP_BA = 0x400D_0000</b>				
<b>CMP0CR</b>	CMP_BA+0x00	R/W	Comparator0 Control Register	0x0000_0000
<b>CMP1CR</b>	CMP_BA+0x04	R/W	Comparator1 Control Register	0x0000_0000
<b>CMPSR</b>	CMP_BA+0x08	R/W	Comparator Status Register	0x0000_0000



5.16.6 Register Description

**CMP0 Control Register (CMP0CR)**

Register	Offset	R/W	Description	Reset Value
CMP0CR	CMP_BA+0x00	R/W	Comparator0 Control Register	0x0000_0000

31	30	29	28	27	26	25	24
Reserved							
23	22	21	20	19	18	17	16
Reserved							
15	14	13	12	11	10	9	8
Reserved							
7	6	5	4	3	2	1	0
Reserved			CMP0CN	Reserved	CMP0_HYSE N	CMP0IE	CMP0EN

Bits	Descriptions	
[31:5]	Reserved	Reserved
[4]	CMP0CN	<b>Comparator0 negative input select</b> 1 = The internal bandgap reference voltage is selected as the source of negative comparator input 0 = The source of the negative comparator input is from CPN0 pin
[3]	Reserved	Reserved
[2]	CMP0_HYSEN	<b>Comparator0 Hysteresis Enable</b> 1 = Enable hysteresis function. The typical range is 20mV. 0 = Disable hysteresis function (Default).
[1]	CMP0IE	<b>Comparator0 Interrupt Enable</b> 1 = Enable interrupt function 0 = Disable interrupt function
[0]	CMP0EN	<b>Comparator0 Enable</b> 1 = Enable 0 = Disable Comparator output need wait 2 us stable time after CMP0EN is set.



**CMP1 Control Register (CMP1CR)**

Register	Offset	R/W	Description	Reset Value
CMP1CR	CMP_BA+0x04	R/W	Comparator1 Control Register	0x0000_0000

31	30	29	28	27	26	25	24
Reserved							
23	22	21	20	19	18	17	16
Reserved							
15	14	13	12	11	10	9	8
Reserved							
7	6	5	4	3	2	1	0
Reserved			CMP1CN	Reserved	CMP1_HYSE N	CMP1IE	CMP1EN

Bits	Descriptions	
[31:5]	Reserved	Reserved
[4]	CMP1CN	<p><b>Comparator1 negative input select</b></p> <p>1 = The internal bandgap reference voltage is selected as the source of negative comparator input</p> <p>0 = The source of the negative comparator input is from CPN1 pin</p>
[3]	Reserved	Reserved
[2]	CMP1_HYSEN	<p><b>Comparator1 Hysteresis Enable</b></p> <p>1 = Enable hysteresis function. The typical range is 20mV.</p> <p>0 = Disable hysteresis function (Default).</p>
[1]	CMP1IE	<p><b>Comparator1 Interrupt Enable</b></p> <p>1 = Enable interrupt function</p> <p>0 = Disable interrupt function</p>
[0]	CMP1EN	<p><b>Comparator1 Enable</b></p> <p>1 = Enable</p> <p>0 = Disable</p> <p>Comparator output need wait 2 us stable time after CMP1EN is set.</p>



**CMP Status Register (CMPSR)**

Register	Offset	R/W	Description	Reset Value
CMPSR	CMP_BA+0x08	R/W	Comparator Status Register	0x0000_0000

31	30	29	28	27	26	25	24
Reserved							
23	22	21	20	19	18	17	16
Reserved							
15	14	13	12	11	10	9	8
Reserved							
7	6	5	4	3	2	1	0
Reserved				CO1	CO0	CMPF1	CMPF0

Bits	Descriptions	
[31:4]	Reserved	Reserved
[3]	CO1	<b>Comparator1 Output</b> Synchronized to the APB clock to allow reading by software. Cleared when the comparator is disabled (CMP1EN = 0).
[2]	CO0	<b>Comparator0 Output</b> Synchronized to the APB clock to allow reading by software. Cleared when the comparator is disabled (CMP0EN = 0).
[1]	CMPF1	<b>Comparator1 Flag</b> This bit is set by hardware whenever the comparator1 output changes state. This will cause an interrupt if CMP1IE set. Write 1 to clear this bit to zero.
[0]	CMPF0	<b>Comparator0 Flag</b> This bit is set by hardware whenever the comparator0 output changes state. This will cause an interrupt if CMP0IE set. Write 1 to clear this bit to zero.

## 5.17 PDMA Controller (PDMA)

### 5.17.1 Overview

NuMicro™ NUC100/NUC120 Medium Density contains a peripheral direct memory access (PDMA) controller that transfers data to and from memory or transfer data to and from APB devices. The PDMA has nine channels of DMA (Peripheral-to-Memory or Memory-to-Peripheral or Memory-to-Memory). For each PDMA channel (PDMA CH0~CH8), there is one word buffer as transfer buffer between the Peripherals APB devices and Memory.

Software can stop the PDMA operation by disable PDMA [PDMACEN]. The CPU can recognize the completion of a PDMA operation by software polling or when it receives an internal PDMA interrupt. The PDMA controller can increase source or destination address or fixed them as well.

Notice: NuMicro™ NUC100/NUC120 Low Density only has 1 PDMA channel (channel 0).

### 5.17.2 Features

- Up to nine DMA channels. Each channel can support a unidirectional transfer (NuMicro™ NUC100/NUC120 Low Density only has 1 PDMA channel)
- AMBA AHB master/slave interface compatible, for data transfer and register read/write
- Support source and destination address increased mode or fixed mode
- Hardware channel priority. DMA channel 0 has the highest priority and channel 8 has the lowest priority

5.17.3 Block Diagram

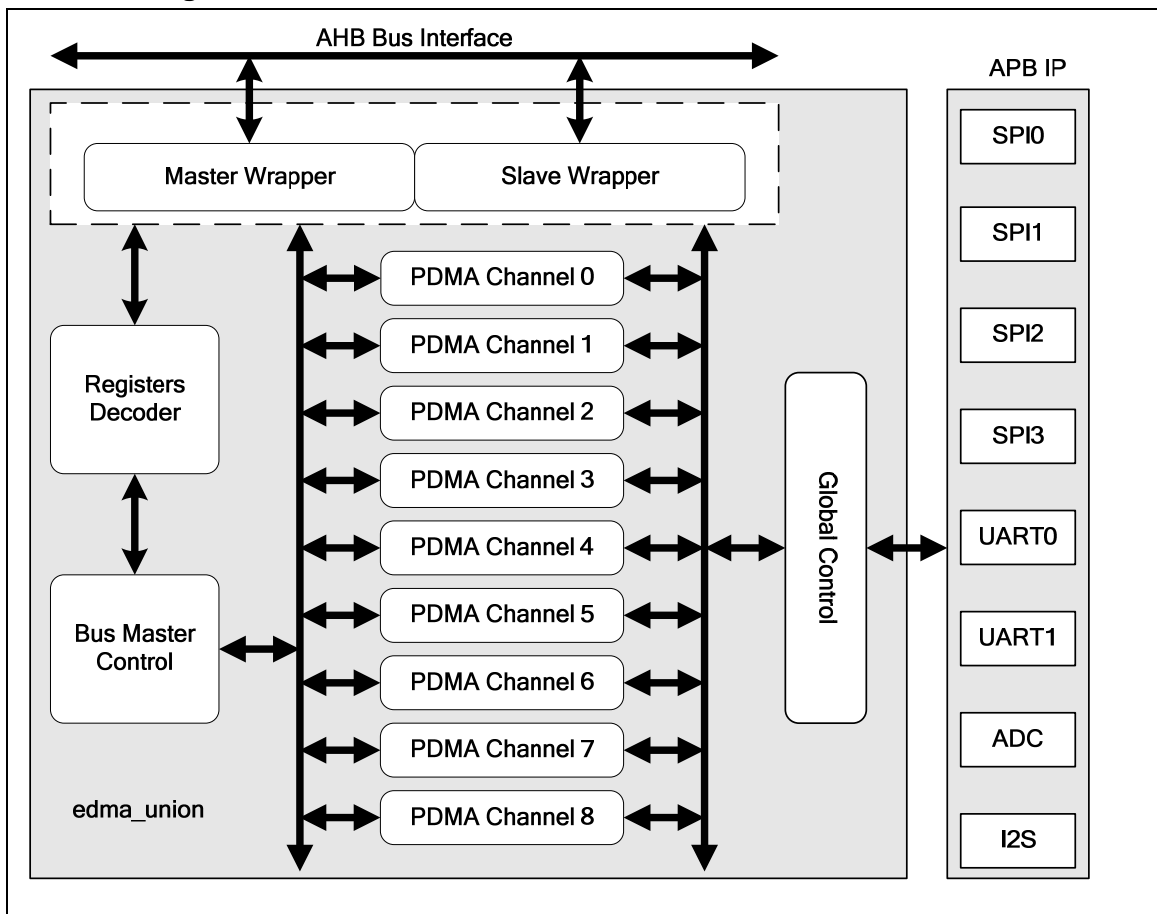

Figure 5-98 NuMicro™ NUC100/NUC120 Medium Density PDMA Controller Block Diagram



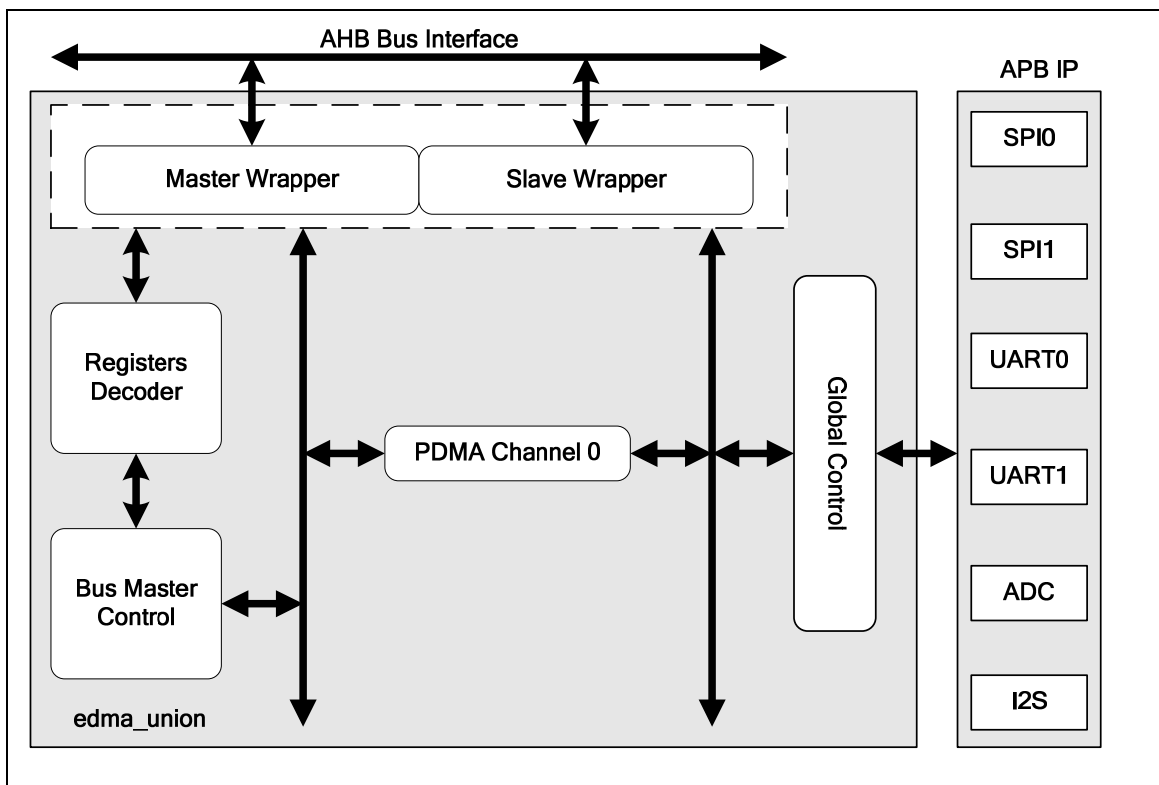

Figure 5-99 NuMicro™ NUC100/NUC120 Low Density PDMA Controller Block Diagram



#### 5.17.4 Function Description

The PDMA controller has up to nine channels of DMA associated with Peripheral-to-Memory, Memory-to-Peripheral or Memory-to-Memory. For each PDMA channel, there is one word memory as transfer buffer between the Peripherals APB IP and Memory.

The CPU can recognize the completion of a PDMA operation by software polling or when it receives an internal PDMA interrupt. As to the source and destination address, the PDMA controller has two modes: increased and fixed.

Every PDMA default channel behavior is not pre-defined, so users must configure the channel service settings of PDMA\_PDSSR0, PDMA\_PDSSR1 and PDMA\_PDSSR2 before start the related PDMA channel.

Software must enable DMA channel PDMA [PDMACEN] and then write a valid source address to the PDMA\_SARx register, a destination address to the PDMA\_DARx register, and a transfer count to the PDMA\_BCRx register. Next, trigger the DMA\_CSRx PDMA [TRIG\_EN]. PDMA will continue the transfer until PDMA\_CBCRx comes down to zero. If an error occurs during the PDMA operation, the channel stops unless software clears the error condition and sets the PDMA\_CSRx [SW\_RST] to reset the PDMA channel and set PDMA\_CSRx [PDMACEN] and [TRIG\_EN] bits field to start again.

In PDMA (Peripheral-to-Memory or Memory-to-Peripheral) mode, DMA can transfer data between the Peripherals APB IP (ex: UART, SPI, ADC....) and Memory.



## 5.17.5 Register Map

R: read only, W: write only, R/W: both read and write

Register	Offset	R/W	Description	Reset Value
<b>PDMA_BA_ch0 = 0x5000_8000    PDMA_BA_ch1 = 0x5000_8100    PDMA_BA_ch2 = 0x5000_8200</b> <b>PDMA_BA_ch3 = 0x5000_8300    PDMA_BA_ch4 = 0x5000_8400    PDMA_BA_ch5 = 0x5000_8500</b> <b>PDMA_BA_ch6 = 0x5000_8600    PDMA_BA_ch7 = 0x5000_8700    PDMA_BA_ch8 = 0x5000_8800</b>				
PDMA_CSRx	PDMA_BA_chx+0x00	R/W	PDMA Control Register	0x0000_0000
PDMA_SARx	PDMA_BA_chx+0x04	R/W	PDMA Source Address Register	0x0000_0000
PDMA_DARx	PDMA_BA_chx+0x08	R/W	PDMA Destination Address Register	0x0000_0000
PDMA_BCRx	PDMA_BA_chx+0x0C	R/W	PDMA Transfer Byte Count Register	0x0000_0000
PDMA_POINTx	PDMA_BA_chx+0x10	R	PDMA Internal buffer pointer	0xXXXX_0000
PDMA_CSARx	PDMA_BA_chx+0x14	R	PDMA Current Source Address Register	0x0000_0000
PDMA_CDARx	PDMA_BA_chx+0x18	R	PDMA Current Destination Address Register	0x0000_0000
PDMA_CBCRx	PDMA_BA_chx+0x1C	R	PDMA Current Transfer Byte Count Register	0x0000_0000
PDMA_IERx	PDMA_BA_chx+0x20	R/W	PDMA Interrupt Enable Register	0x0000_0001
PDMA_ISRx	PDMA_BA_chx+0x24	R/W	PDMA Interrupt Status Register	0x0000_0000
PDMA_SBUF0_cx	PDMA_BA_chx+0x80	R	PDMA Shared Buffer FIFO 0	0x0000_0000
<b>PDMA_BA_GCR = 0x5000_8F00</b>				
PDMA_GCRCsr	PDMA_BA_GCR+0x00	R/W	PDMA Global Control Register	0x0000_0000
PDMA_PDSSR0	PDMA_BA_GCR+0x04	R/W	PDMA Service Selection Control Register 0	0xFFFF_FFFF
PDMA_PDSSR1	PDMA_BA_GCR+0x08	R/W	PDMA Service Selection Control Register 1	0xFFFF_FFFF
PDMA_GCRISR	PDMA_BA_GCR+0x0C	R/W	PDMA Global Interrupt Register	0x0000_0000
PDMA_PDSSR2	PDMA_BA_GCR+0x10	R/W	PDMA Service Selection Control Register 2	0x0000_00FF

Notice: NuMicro™ NUC100/NUC120 Low Density only support PDMA channel 0.



5.17.6 Register Description

**PDMA Control and Status Register (PDMA\_CSRx)**

Register	Offset	R/W	Description	Reset Value
PDMA_CSR0	PDMA_BA_ch0+0x00	R/W	PDMA Control and Status Register CH0	0x0000_0000
PDMA_CSR1	PDMA_BA_ch1+0x00	R/W	PDMA Control and Status Register CH1	0x0000_0000
PDMA_CSR2	PDMA_BA_ch2+0x00	R/W	PDMA Control and Status Register CH2	0x0000_0000
PDMA_CSR3	PDMA_BA_ch3+0x00	R/W	PDMA Control and Status Register CH3	0x0000_0000
PDMA_CSR4	PDMA_BA_ch4+0x00	R/W	PDMA Control and Status Register CH4	0x0000_0000
PDMA_CSR5	PDMA_BA_ch5+0x00	R/W	PDMA Control and Status Register CH5	0x0000_0000
PDMA_CSR6	PDMA_BA_ch6+0x00	R/W	PDMA Control and Status Register CH6	0x0000_0000
PDMA_CSR7	PDMA_BA_ch7+0x00	R/W	PDMA Control and Status Register CH7	0x0000_0000
PDMA_CSR8	PDMA_BA_ch8+0x00	R/W	PDMA Control and Status Register CH8	0x0000_0000

Notice: NuMicro™ NUC100/NUC120 Low Density only support PDMA channel 0.

31	30	29	28	27	26	25	24
Reserved							
23	22	21	20	19	18	17	16
TRIG_EN	Reserved		APB_TWS		Reserved		
15	14	13	12	11	10	9	8
Reserved							
7	6	5	4	3	2	1	0
DAD_SEL		SAD_SEL		MODE_SEL		SW_RST	PDMACEN

Bits	Descriptions	
[31:24]	Reserved	Reserved
[23]	TRIG_EN	<p><b>Trigger Enable</b></p> <p>1 = Enable PDMA data read or write transfer.</p> <p>0 = No effect.</p> <p>Note: When PDMA transfer completed, this bit will be cleared automatically.</p> <p>If the bus error occurs, all PDMA transfer will be stopped. Software must reset all PDMA channel, and then trigger again.</p>
[22:21]	Reserved	Reserved



Bits	Descriptions	
[20:19]	<b>APB_TWS</b>	<p><b>Peripheral transfer Width Select</b></p> <p>00 = One word (32-bit) is transferred for every PDMA operation.                      01 = One byte (8-bit) is transferred for every PDMA operation.                      10 = One half-word (16-bit) is transferred for every PDMA operation.                      11 = Reserved.</p> <p>Note: This field is meaningful only when MODE_SEL is Peripheral to Memory mode (Peripheral-to-Memory) or Memory to Peripheral mode (Memory-to-Peripheral).</p>
[18:8]	<b>Reserved</b>	Reserved
[7:6]	<b>DAD_SEL</b>	<p><b>Transfer Destination Address Direction Select</b></p> <p>00 = Transfer Destination address is increasing successively.                      01 = Reserved.                      10 = Transfer Destination address is fixed (This feature can be used when data where transferred from multiple sources to a single destination).                      11 = Reserved.</p>
[5:4]	<b>SAD_SEL</b>	<p><b>Transfer Source Address Direction Select</b></p> <p>00 = Transfer Source address is increasing successively.                      01 = Reserved.                      10 = Transfer Source address is fixed (This feature can be used when data where transferred from a single source to multiple destinations).                      11 = Reserved.</p>
[3:2]	<b>MODE_SEL</b>	<p><b>PDMA Mode Select</b></p> <p>00 = Memory to Memory mode (Memory-to-Memory).                      01 = Peripheral to Memory mode (Peripheral-to-Memory).                      10 = Memory to Peripheral mode (Memory-to-Peripheral).</p>
[1]	<b>SW_RST</b>	<p><b>Software Engine Reset</b></p> <p>0 = Writing 0 to this bit has no effect.                      1 = Writing 1 to this bit will reset the internal state machine, pointers and internal buffer. The contents of control register will not be cleared. This bit will auto clear after few clock cycles.</p>
[0]	<b>PDMACEN</b>	<p><b>PDMA Channel Enable</b></p> <p>Setting this bit to 1 enables PDMA's operation. If this bit is cleared, PDMA will ignore all PDMA request and force Bus Master into IDLE state.</p> <p>Note: SW_RST(PDMA_CSRx[1], x= 0~8) will clear this bit</p>



## PDMA Transfer Source Address Register (PDMA\_SARx)

Register	Offset	R/W	Description	Reset Value
PDMA_SAR0	PDMA_BA_ch0+0x04	R/W	PDMA Transfer Source Address Register CH0	0x0000_0000
PDMA_SAR1	PDMA_BA_ch1+0x04	R/W	PDMA Transfer Source Address Register CH1	0x0000_0000
PDMA_SAR2	PDMA_BA_ch2+0x04	R/W	PDMA Transfer Source Address Register CH2	0x0000_0000
PDMA_SAR3	PDMA_BA_ch3+0x04	R/W	PDMA Transfer Source Address Register CH3	0x0000_0000
PDMA_SAR4	PDMA_BA_ch4+0x04	R/W	PDMA Transfer Source Address Register CH4	0x0000_0000
PDMA_SAR5	PDMA_BA_ch5+0x04	R/W	PDMA Transfer Source Address Register CH5	0x0000_0000
PDMA_SAR6	PDMA_BA_ch6+0x04	R/W	PDMA Transfer Source Address Register CH6	0x0000_0000
PDMA_SAR7	PDMA_BA_ch7+0x04	R/W	PDMA Transfer Source Address Register CH7	0x0000_0000
PDMA_SAR8	PDMA_BA_ch8+0x04	R/W	PDMA Transfer Source Address Register CH8	0x0000_0000

Notice: NuMicro™ NUC100/NUC120 Low Density only support PDMA channel 0.

31	30	29	28	27	26	25	24
PDMA_SAR [31:24]							
23	22	21	20	19	18	17	16
PDMA_SAR [23:16]							
15	14	13	12	11	10	9	8
PDMA_SAR [15:8]							
7	6	5	4	3	2	1	0
PDMA_SAR [7:0]							

Bits	Descriptions	
[31:0]	PDMA_SAR	<p><b>PDMA Transfer Source Address Register</b></p> <p>This field indicates a 32-bit source address of PDMA.</p> <p>Note : The source address must be word alignment</p>



## PDMA Transfer Destination Address Register (PDMA\_DARx)

Register	Offset	R/W	Description	Reset Value
PDMA_DAR0	PDMA_BA_ch0+0x08	R/W	PDMA Transfer Destination Address Register CH0	0x0000_0000
PDMA_DAR1	PDMA_BA_ch1+0x08	R/W	PDMA Transfer Destination Address Register CH1	0x0000_0000
PDMA_DAR2	PDMA_BA_ch2+0x08	R/W	PDMA Transfer Destination Address Register CH2	0x0000_0000
PDMA_DAR3	PDMA_BA_ch3+0x08	R/W	PDMA Transfer Destination Address Register CH3	0x0000_0000
PDMA_DAR4	PDMA_BA_ch4+0x08	R/W	PDMA Transfer Destination Address Register CH4	0x0000_0000
PDMA_DAR5	PDMA_BA_ch5+0x08	R/W	PDMA Transfer Destination Address Register CH5	0x0000_0000
PDMA_DAR6	PDMA_BA_ch6+0x08	R/W	PDMA Transfer Destination Address Register CH6	0x0000_0000
PDMA_DAR7	PDMA_BA_ch7+0x08	R/W	PDMA Transfer Destination Address Register CH7	0x0000_0000
PDMA_DAR8	PDMA_BA_ch8+0x08	R/W	PDMA Transfer Destination Address Register CH8	0x0000_0000

Notice: NuMicro™ NUC100/NUC120 Low Density only support PDMA channel 0.

31	30	29	28	27	26	25	24
PDMA_DAR [31:24]							
23	22	21	20	19	18	17	16
PDMA_DAR [23:16]							
15	14	13	12	11	10	9	8
PDMA_DAR [15:8]							
7	6	5	4	3	2	1	0
PDMA_DAR [7:0]							

Bits	Descriptions	
[31:0]	<b>PDMA_DAR</b>	<b>PDMA Transfer Destination Address Register</b> This field indicates a 32-bit destination address of PDMA. Note : The destination address must be word alignment



## PDMA Transfer Byte Count Register (PDMA\_BCRx)

Register	Offset	R/W	Description	Reset Value
PDMA_BCR0	PDMA_BA_ch0+0x0C	R/W	PDMA Transfer Byte Count Register CH0	0x0000_0000
PDMA_BCR1	PDMA_BA_ch1+0x0C	R/W	PDMA Transfer Byte Count Register CH1	0x0000_0000
PDMA_BCR2	PDMA_BA_ch2+0x0C	R/W	PDMA Transfer Byte Count Register CH2	0x0000_0000
PDMA_BCR3	PDMA_BA_ch3+0x0C	R/W	PDMA Transfer Byte Count Register CH3	0x0000_0000
PDMA_BCR4	PDMA_BA_ch4+0x0C	R/W	PDMA Transfer Byte Count Register CH4	0x0000_0000
PDMA_BCR5	PDMA_BA_ch5+0x0C	R/W	PDMA Transfer Byte Count Register CH5	0x0000_0000
PDMA_BCR6	PDMA_BA_ch6+0x0C	R/W	PDMA Transfer Byte Count Register CH6	0x0000_0000
PDMA_BCR7	PDMA_BA_ch7+0x0C	R/W	PDMA Transfer Byte Count Register CH7	0x0000_0000
PDMA_BCR8	PDMA_BA_ch8+0x0C	R/W	PDMA Transfer Byte Count Register CH8	0x0000_0000

Notice: NuMicro™ NUC100/NUC120 Low Density only support PDMA channel 0.

31	30	29	28	27	26	25	24
Reserved							
23	22	21	20	19	18	17	16
Reserved							
15	14	13	12	11	10	9	8
PDMA_BCR [15:8]							
7	6	5	4	3	2	1	0
PDMA_BCR [7:0]							

Bits	Descriptions	
[31:16]	Reserved	Reserved
[15:0]	PDMA_BCR	<b>PDMA Transfer Byte Count Register</b> This field indicates a 16-bit transfer byte count number of PDMA, it must be word alignment.





### PDMA Internal Buffer Pointer Register (PDMA\_POINTx)

Register	Offset	R/W	Description	Reset Value
PDMA_POINT0	PDMA_BA_ch0+0x10	R	PDMA Internal Buffer Pointer Register CH0	0xFFFF_0000
PDMA_POINT1	PDMA_BA_ch1+0x10	R	PDMA Internal Buffer Pointer Register CH1	0xFFFF_0000
PDMA_POINT2	PDMA_BA_ch2+0x10	R	PDMA Internal Buffer Pointer Register CH2	0xFFFF_0000
PDMA_POINT3	PDMA_BA_ch3+0x10	R	PDMA Internal Buffer Pointer Register CH3	0xFFFF_0000
PDMA_POINT4	PDMA_BA_ch4+0x10	R	PDMA Internal Buffer Pointer Register CH4	0xFFFF_0000
PDMA_POINT5	PDMA_BA_ch5+0x10	R	PDMA Internal Buffer Pointer Register CH5	0xFFFF_0000
PDMA_POINT6	PDMA_BA_ch6+0x10	R	PDMA Internal Buffer Pointer Register CH6	0xFFFF_0000
PDMA_POINT7	PDMA_BA_ch7+0x10	R	PDMA Internal Buffer Pointer Register CH7	0xFFFF_0000
PDMA_POINT8	PDMA_BA_ch8+0x10	R	PDMA Internal Buffer Pointer Register CH8	0xFFFF_0000

Notice: NuMicro™ NUC100/NUC120 Low Density only support PDMA channel 0.

31	30	29	28	27	26	25	24
Reserved							
23	22	21	20	19	18	17	16
Reserved							
15	14	13	12	11	10	9	8
Reserved							
7	6	5	4	3	2	1	0
Reserved				PDMA_POINT			

Bits	Descriptions	
[31:2]	Reserved	Reserved
[1:0]	PDMA_POINT	PDMA Internal Buffer Pointer Register (Read Only) This field indicates the internal buffer pointer.



## PDMA Current Source Address Register (PDMA\_CSARx)

Register	Offset	R/W	Description	Reset Value
PDMA_CSAR0	PDMA_BA_ch0+0x14	R	PDMA Current Source Address Register CH0	0x0000_0000
PDMA_CSAR1	PDMA_BA_ch1+0x14	R	PDMA Current Source Address Register CH1	0x0000_0000
PDMA_CSAR2	PDMA_BA_ch2+0x14	R	PDMA Current Source Address Register CH2	0x0000_0000
PDMA_CSAR3	PDMA_BA_ch3+0x14	R	PDMA Current Source Address Register CH3	0x0000_0000
PDMA_CSAR4	PDMA_BA_ch4+0x14	R	PDMA Current Source Address Register CH4	0x0000_0000
PDMA_CSAR5	PDMA_BA_ch5+0x14	R	PDMA Current Source Address Register CH5	0x0000_0000
PDMA_CSAR6	PDMA_BA_ch6+0x14	R	PDMA Current Source Address Register CH6	0x0000_0000
PDMA_CSAR7	PDMA_BA_ch7+0x14	R	PDMA Current Source Address Register CH7	0x0000_0000
PDMA_CSAR8	PDMA_BA_ch8+0x14	R	PDMA Current Source Address Register CH8	0x0000_0000

Notice: NuMicro™ NUC100/NUC120 Low Density only support PDMA channel 0.

31	30	29	28	27	26	25	24
PDMA_CSAR [31:24]							
23	22	21	20	19	18	17	16
PDMA_CSAR [23:16]							
15	14	13	12	11	10	9	8
PDMA_CSAR [15:8]							
7	6	5	4	3	2	1	0
PDMA_CSAR [7:0]							

Bits	Descriptions	
[31:0]	PDMA_CSAR	<b>PDMA Current Source Address Register (Read Only)</b> This field indicates the source address where the PDMA transfer is just occurring.



## PDMA Current Destination Address Register (PDMA\_CDARx)

Register	Offset	R/W	Description	Reset Value
PDMA_CDAR0	PDMA_BA_ch0+0x18	R	PDMA Current Destination Address Register CH0	0x0000_0000
PDMA_CDAR1	PDMA_BA_ch1+0x18	R	PDMA Current Destination Address Register CH1	0x0000_0000
PDMA_CDAR2	PDMA_BA_ch2+0x18	R	PDMA Current Destination Address Register CH2	0x0000_0000
PDMA_CDAR3	PDMA_BA_ch3+0x18	R	PDMA Current Destination Address Register CH3	0x0000_0000
PDMA_CDAR4	PDMA_BA_ch4+0x18	R	PDMA Current Destination Address Register CH4	0x0000_0000
PDMA_CDAR5	PDMA_BA_ch5+0x18	R	PDMA Current Destination Address Register CH5	0x0000_0000
PDMA_CDAR6	PDMA_BA_ch6+0x18	R	PDMA Current Destination Address Register CH6	0x0000_0000
PDMA_CDAR7	PDMA_BA_ch7+0x18	R	PDMA Current Destination Address Register CH7	0x0000_0000
PDMA_CDAR8	PDMA_BA_ch8+0x18	R	PDMA Current Destination Address Register CH8	0x0000_0000

Notice: NuMicro™ NUC100/NUC120 Low Density only support PDMA channel 0.

31	30	29	28	27	26	25	24
PDMA_CDAR [31:24]							
23	22	21	20	19	18	17	16
PDMA_CDAR [23:16]							
15	14	13	12	11	10	9	8
PDMA_CDAR [15:8]							
7	6	5	4	3	2	1	0
PDMA_CDAR [7:0]							

Bits	Descriptions	
[31:0]	PDMA_CDAR	<b>PDMA Current Destination Address Register (Read Only)</b> This field indicates the destination address where the PDMA transfer is just occurring.



## PDMA Current Byte Count Register (PDMA\_CBCRx)

Register	Offset	R/W	Description	Reset Value
PDMA_CBCR0	PDMA_BA_ch0+0x1C	R	PDMA Current Byte Count Register CH0	0x0000_0000
PDMA_CBCR1	PDMA_BA_ch1+0x1C	R	PDMA Current Byte Count Register CH1	0x0000_0000
PDMA_CBCR2	PDMA_BA_ch2+0x1C	R	PDMA Current Byte Count Register CH2	0x0000_0000
PDMA_CBCR3	PDMA_BA_ch3+0x1C	R	PDMA Current Byte Count Register CH3	0x0000_0000
PDMA_CBCR4	PDMA_BA_ch4+0x1C	R	PDMA Current Byte Count Register CH4	0x0000_0000
PDMA_CBCR5	PDMA_BA_ch5+0x1C	R	PDMA Current Byte Count Register CH5	0x0000_0000
PDMA_CBCR6	PDMA_BA_ch6+0x1C	R	PDMA Current Byte Count Register CH6	0x0000_0000
PDMA_CBCR7	PDMA_BA_ch7+0x1C	R	PDMA Current Byte Count Register CH7	0x0000_0000
PDMA_CBCR8	PDMA_BA_ch8+0x1C	R	PDMA Current Byte Count Register CH8	0x0000_0000

Notice: NuMicro™ NUC100/NUC120 Low Density only support PDMA channel 0.

31	30	29	28	27	26	25	24
Reserved							
23	22	21	20	19	18	17	16
Reserved							
15	14	13	12	11	10	9	8
PDMA_CBCR [15:8]							
7	6	5	4	3	2	1	0
PDMA_CBCR [7:0]							

Bits	Descriptions	
[31:16]	Reserved	Reserved
[15:0]	PDMA_CBCR	<b>PDMA Current Byte Count Register (Read Only)</b> This field indicates the current remained byte count of PDMA. Note: SW_RST will clear this register value.



## PDMA Interrupt Enable Control Register (PDMA\_IERx)

Register	Offset	R/W	Description	Reset Value
PDMA_IER0	PDMA_BA_ch0+0x20	R/W	PDMA Interrupt Enable Control Register CH0	0x0000_0001
PDMA_IER1	PDMA_BA_ch1+0x20	R/W	PDMA Interrupt Enable Control Register CH1	0x0000_0001
PDMA_IER2	PDMA_BA_ch2+0x20	R/W	PDMA Interrupt Enable Control Register CH2	0x0000_0001
PDMA_IER3	PDMA_BA_ch3+0x20	R/W	PDMA Interrupt Enable Control Register CH3	0x0000_0001
PDMA_IER4	PDMA_BA_ch4+0x20	R/W	PDMA Interrupt Enable Control Register CH4	0x0000_0001
PDMA_IER5	PDMA_BA_ch5+0x20	R/W	PDMA Interrupt Enable Control Register CH5	0x0000_0001
PDMA_IER6	PDMA_BA_ch6+0x20	R/W	PDMA Interrupt Enable Control Register CH6	0x0000_0001
PDMA_IER7	PDMA_BA_ch7+0x20	R/W	PDMA Interrupt Enable Control Register CH7	0x0000_0001
PDMA_IER8	PDMA_BA_ch8+0x20	R/W	PDMA Interrupt Enable Control Register CH8	0x0000_0001

Notice: NuMicro™ NUC100/NUC120 Low Density only support PDMA channel 0.

31	30	29	28	27	26	25	24
Reserved							
23	22	21	20	19	18	17	16
Reserved							
15	14	13	12	11	10	9	8
Reserved							
7	6	5	4	3	2	1	0
Reserved						BLKD_IE	TABORT_IE

Bits	Descriptions	
[31:2]	Reserved	Reserved
[1]	BLKD_IE	<b>PDMA Transfer Done Interrupt Enable</b> 1 = Enable interrupt generator during PDMA transfer done. 0 = Disable interrupt generator during PDMA transfer done.
[0]	TABORT_IE	<b>PDMA Read/Write Target Abort Interrupt Enable</b> 1 = Enable target abort interrupt generation during PDMA transfer. 0 = Disable target abort interrupt generation during PDMA transfer.



## PDMA Interrupt Status Register (PDMA\_ISRx)

Register	Offset	R/W	Description	Reset Value
PDMA_ISR0	PDMA_BA_ch0+0x24	R/W	PDMA Interrupt Status Register CH0	0x0X0X_0000
PDMA_ISR1	PDMA_BA_ch1+0x24	R/W	PDMA Interrupt Status Register CH1	0x0X0X_0000
PDMA_ISR2	PDMA_BA_ch2+0x24	R/W	PDMA Interrupt Status Register CH2	0x0X0X_0000
PDMA_ISR3	PDMA_BA_ch3+0x24	R/W	PDMA Interrupt Status Register CH3	0x0X0X_0000
PDMA_ISR4	PDMA_BA_ch4+0x24	R/W	PDMA Interrupt Status Register CH4	0x0X0X_0000
PDMA_ISR5	PDMA_BA_ch5+0x24	R/W	PDMA Interrupt Status Register CH5	0x0X0X_0000
PDMA_ISR6	PDMA_BA_ch6+0x24	R/W	PDMA Interrupt Status Register CH6	0x0X0X_0000
PDMA_ISR7	PDMA_BA_ch7+0x24	R/W	PDMA Interrupt Status Register CH7	0x0X0X_0000
PDMA_ISR8	PDMA_BA_ch8+0x24	R/W	PDMA Interrupt Status Register CH8	0x0X0X_0000

Notice: NuMicro™ NUC100/NUC120 Low Density only support PDMA channel 0.

31	30	29	28	27	26	25	24
<b>Reserved</b>							
23	22	21	20	19	18	17	16
<b>Reserved</b>							
15	14	13	12	11	10	9	8
<b>Reserved</b>							
7	6	5	4	3	2	1	0
<b>Reserved</b>						BLKD_IF	TABORT_IF

Bits	Descriptions	
[31:2]	<b>Reserved</b>	Reserved
[1]	<b>BLKD_IF</b>	<p><b>Block Transfer Done Interrupt Flag</b></p> <p>This bit indicates that PDMA has finished all transfer.</p> <p>1 = Done</p> <p>0 = Not finished yet</p> <p>Software can write 1 to clear this bit to zero</p>
[0]	<b>TABORT_IF</b>	<p><b>PDMA Read/Write Target Abort Interrupt Flag</b></p> <p>1 = Bus ERROR response received</p> <p>0 = No bus ERROR response received</p> <p>Software can write 1 to clear this bit to zero</p>

Note: The PDMA\_ISR [TABORT\_IF] indicate bus master received ERROR response or not. If bus master received



ERROR response, it means that target abort is happened. PDMAc will stop transfer and respond this event to software then go to IDLE state. When target abort occurred, software must reset PDMA, and then transfer those data again.

### PDMA Shared Buffer FIFO 0 (PDMA\_SBUF0\_cx)

Register	Offset	R/W	Description	Reset Value
PDMA_SBUF0_c0	PDMA_BA_ch0+0x080	R	PDMA Shared Buffer FIFO 0 Register CH0	0x0000_0000
PDMA_SBUF0_c1	PDMA_BA_ch1+0x180	R	PDMA Shared Buffer FIFO 0 Register CH1	0x0000_0000
PDMA_SBUF0_c2	PDMA_BA_ch2+0x280	R	PDMA Shared Buffer FIFO 0 Register CH2	0x0000_0000
PDMA_SBUF0_c3	PDMA_BA_ch3+0x380	R	PDMA Shared Buffer FIFO 0 Register CH3	0x0000_0000
PDMA_SBUF0_c4	PDMA_BA_ch4+0x480	R	PDMA Shared Buffer FIFO 0 Register CH4	0x0000_0000
PDMA_SBUF0_c5	PDMA_BA_ch5+0x580	R	PDMA Shared Buffer FIFO 0 Register CH5	0x0000_0000
PDMA_SBUF0_c6	PDMA_BA_ch6+0x680	R	PDMA Shared Buffer FIFO 0 Register CH6	0x0000_0000
PDMA_SBUF0_c7	PDMA_BA_ch7+0x780	R	PDMA Shared Buffer FIFO 0 Register CH7	0x0000_0000
PDMA_SBUF0_c8	PDMA_BA_ch8+0x880	R	PDMA Shared Buffer FIFO 0 Register CH8	0x0000_0000

Notice: NuMicro™ NUC100/NUC120 Low Density only support PDMA channel 0.

31	30	29	28	27	26	25	24
PDMA_SBUF0 [31:24]							
23	22	21	20	19	18	17	16
PDMA_SBUF0 [23:16]							
15	14	13	12	11	10	9	8
PDMA_SBUF0 [15:8]							
7	6	5	4	3	2	1	0
PDMA_SBUF0 [7:0]							

Bits	Descriptions
[31:0]	<b>PDMA_SBUF0</b> PDMA Shared Buffer FIFO 0 (Read Only) Each channel has its own 1 words internal buffer.



## PDMA Global Control Register (PDMA\_GCRCSR)

Register	Offset	R/W	Description	Reset Value
PDMA_GCRCSR	PDMA_BA_GCR+0x00	R/W	PDMA Global Control Register	0x0000_0000

31	30	29	28	27	26	25	24
Reserved							
23	22	21	20	19	18	17	16
Reserved							CLK8_EN
15	14	13	12	11	10	9	8
CLK7_EN	CLK6_EN	CLK5_EN	CLK4_EN	CLK3_EN	CLK2_EN	CLK1_EN	CLK0_EN
7	6	5	4	3	2	1	0
Reserved							

Bits	Descriptions	
[31:17]	Reserved	Reserved
[16]	CLK8_EN	<b>PDMA Controller Channel 8 Clock Enable Control</b> (NuMicro™ NUC100/NUC120 Medium Density Only) 0 = Disable 1 = Enable
[15]	CLK7_EN	<b>PDMA Controller Channel 7 Clock Enable Control</b> (NuMicro™ NUC100/NUC120 Medium Density Only) 0 = Disable 1 = Enable
[14]	CLK6_EN	<b>PDMA Controller Channel 6 Clock Enable Control</b> (NuMicro™ NUC100/NUC120 Medium Density Only) 0 = Disable 1 = Enable
[13]	CLK5_EN	<b>PDMA Controller Channel 5 Clock Enable Control</b> (NuMicro™ NUC100/NUC120 Medium Density Only) 0 = Disable 1 = Enable
[12]	CLK4_EN	<b>PDMA Controller Channel 4 Clock Enable Control</b> (NuMicro™ NUC100/NUC120 Medium Density Only) 0 = Disable 1 = Enable





Bits	Descriptions	
[11]	<b>CLK3_EN</b>	<b>PDMA Controller Channel 3 Clock Enable Control</b> (NuMicro™ NUC100/NUC120 Medium Density Only) 0 = Disable 1 = Enable
[10]	<b>CLK2_EN</b>	<b>PDMA Controller Channel 2 Clock Enable Control</b> (NuMicro™ NUC100/NUC120 Medium Density Only) 0 = Disable 1 = Enable
[9]	<b>CLK1_EN</b>	<b>PDMA Controller Channel 1 Clock Enable Control</b> (NuMicro™ NUC100/NUC120 Medium Density Only) 0 = Disable 1 = Enable
[8]	<b>CLK0_EN</b>	<b>PDMA Controller Channel 0 Clock Enable Control</b> 0 = Disable 1 = Enable
[7:0]	<b>Reserved</b>	Reserved



## PDMA Service Selection Control Register 0 (PDMA\_PDSSR0)

Register	Address	R/W	Description	Reset Value
PDMA_PDSSR0	PDMA_BA_GCR+0x04	R/W	PDMA Service Selection Control Register 0	0xFFFF_FFFF

31	30	29	28	27	26	25	24
SPI3_TXSEL				SPI3_RXSEL			
23	22	21	20	19	18	17	16
SPI2_TXSEL				SPI2_RXSEL			
15	14	13	12	11	10	9	8
SPI1_TXSEL				SPI1_RXSEL			
7	6	5	4	3	2	1	0
SPI0_TXSEL				SPI0_RXSEL			

Bits	Descriptions	
[31:28]	<b>SPI3_TXSEL</b>	<b>PDMA SPI3 TX Selection</b> (NuMicro™ NUC100/NUC120 Medium Density Only) This field defines which PDMA channel is connected to the on-chip peripheral SPI3 TX. Software can configure the TX channel setting by SPI3_TXSEL. The channel configuration is the same as SPI0_RXSEL field. Please refer to the explanation of SPI0_RXSEL.
[27:24]	<b>SPI3_RXSEL</b>	<b>PDMA SPI3 RX Selection</b> (NuMicro™ NUC100/NUC120 Medium Density Only) This field defines which PDMA channel is connected to the on-chip peripheral SPI3 RX. Software can configure the RX channel setting by SPI3_RXSEL. The channel configuration is the same as SPI0_RXSEL field. Please refer to the explanation of SPI0_RXSEL.
[23:20]	<b>SPI2_TXSEL</b>	<b>PDMA SPI2 TX Selection</b> (NuMicro™ NUC100/NUC120 Medium Density Only) This field defines which PDMA channel is connected to the on-chip peripheral SPI2 TX. Software can configure the TX channel setting by SPI2_TXSEL. The channel configuration is the same as SPI0_RXSEL field. Please refer to the explanation of SPI0_RXSEL.
[19:16]	<b>SPI2_RXSEL</b>	<b>PDMA SPI2 RX Selection</b> (NuMicro™ NUC100/NUC120 Medium Density Only) This field defines which PDMA channel is connected to the on-chip peripheral SPI2 RX. Software can configure the RX channel setting by SPI2_RXSEL. The channel configuration is the same as SPI0_RXSEL field. Please refer to the explanation of SPI0_RXSEL.
[15:12]	<b>SPI1_TXSEL</b>	<b>PDMA SPI1 TX Selection</b> This field defines which PDMA channel is connected to the on-chip peripheral SPI1 TX. Software can configure the TX channel setting by SPI1_TXSEL. The channel configuration is the same as SPI0_RXSEL field. Please refer to the explanation of SPI0_RXSEL.



Bits	Descriptions	
[11:8]	<b>SPI1_RXSEL</b>	<p><b>PDMA SPI1 RX Selection</b></p> <p>This field defines which PDMA channel is connected to the on-chip peripheral SPI1 RX. Software can configure the RX channel setting by SPI1_RXSEL. The channel configuration is the same as SPI0_RXSEL field. Please refer to the explanation of SPI0_RXSEL.</p>
[7:4]	<b>SPI0_TXSEL</b>	<p><b>PDMA SPI0 TX Selection</b></p> <p>This field defines which PDMA channel is connected to the on-chip peripheral SPI0 TX. Software can configure the TX channel setting by SPI0_TXSEL. The channel configuration is the same as SPI0_RXSEL field. Please refer to the explanation of SPI0_RXSEL.</p>
[3:0]	<b>SPI0_RXSEL</b>	<p><b>PDMA SPI0 RX Selection</b></p> <p>This field defines which PDMA channel is connected to the on-chip peripheral SPI0 RX. Software can change the channel RX setting by SPI0_RXSEL</p> <p>4'b0000: CH0                      4'b0001: CH1                      4'b0010: CH2                      4'b0011: CH3                      4'b0100: CH4                      4'b0101: CH5                      4'b0110: CH6                      4'b0111: CH7                      4'b1000: CH8</p> <p>Others : Reserved</p> <p>Note: Ex : SPI0_RXSEL = 4'b0110, that means SPI0_RX is connected to PDMA_CH6 (NuMicro™ NUC100/NUC120 Low Density should set as 4'b0000 for PDMA channel 0 only)</p>



**PDMA Service Selection Control Register 1 (PDMA\_PDSSR1)**

Register	Address	R/W	Description	Reset Value
PDMA_PDSSR1	PDMA_BA_GCR+0x08	R/W	PDMA Service Selection Control Register 1	0xFFFF_FFFF

31	30	29	28	27	26	25	24
Reserved				ADC_RXSEL			
23	22	21	20	19	18	17	16
Reserved							
15	14	13	12	11	10	9	8
UART1_TXSEL				UART1_RXSEL			
7	6	5	4	3	2	1	0
UART0_TXSEL				UART0_RXSEL			

Bits	Descriptions	
[31:28]	Reserved	Reserved
[27:24]	ADC_RXSEL	<b>PDMA ADC RX Selection</b> This field defines which PDMA channel is connected to the on-chip peripheral ADC RX. Software can configure the RX channel setting by ADC_RXSEL. The channel configuration is the same as UART0_RXSEL field. Please refer to the explanation of UART0_RXSEL.
[23:16]	Reserved	Reserved
[15:12]	UART1_TXSEL	<b>PDMA UART1 TX Selection</b> This field defines which PDMA channel is connected to the on-chip peripheral UART1 TX. Software can configure the TX channel setting by UART1_TXSEL. The channel configuration is the same as UART0_RXSEL field. Please refer to the explanation of UART0_RXSEL.
[11:8]	UART1_RXSEL	<b>PDMA UART1 RX Selection</b> This field defines which PDMA channel is connected to the on-chip peripheral UART1 RX. Software can configure the RX channel setting by UART1_RXSEL. The channel configuration is the same as UART0_RXSEL field. Please refer to the explanation of UART0_RXSEL.
[7:4]	UART0_TXSEL	<b>PDMA UART0 TX Selection</b> This field defines which PDMA channel is connected to the on-chip peripheral UART0 TX. Software can configure the TX channel setting by UART0_TXSEL. The channel configuration is the same as UART0_RXSEL field. Please refer to the explanation of UART0_RXSEL.



Bits	Descriptions
[3:0]	<p>This field defines which PDMA channel is connected to the on-chip peripheral UART0 RX. Software can change the channel RX setting by UART0_RXSEL</p> <p>4'b0000: CH0            4'b0001: CH1            4'b0010: CH2            4'b0011: CH3            4'b0100: CH4            4'b0101: CH5            4'b0110: CH6            4'b0111: CH7            4'b1000: CH8            Others : Reserved</p> <p>Note: Ex : UART0_RXSEL = 4'b0110, that means UART0_RX is connected to PDMA_CH6            (NuMicro™ NUC100/NUC120 Low Density should set as 4'b0000 for PDMA channel 0 only)</p>



## PDMA Global Interrupt Status Register (PDMA\_GCRISR)

Register	Offset	R/W	Description	Reset Value
PDMA_GCRISR	PDMA_BA_GCR+0x0C	R	PDMA Global Interrupt Status Register	0x0000_0000

31	30	29	28	27	26	25	24
INTR		Reserved					
23	22	21	20	19	18	17	16
Reserved							
15	14	13	12	11	10	9	8
Reserved							INTR8
7	6	5	4	3	2	1	0
INTR7	INTR6	INTR5	INTR4	INTR3	INTR2	INTR1	INTR0

Bits	Descriptions	
[31]	INTR	<p><b>Interrupt Pin Status</b></p> <p>This bit is the Interrupt status of PDMA controller.</p> <p>Note: This bit is read only</p>
[30:9]	Reserved	Reserved
[8]	INTR8	<p><b>Interrupt Pin Status of Channel 8</b> (NuMicro™ NUC100/NUC120 Medium Density Only)</p> <p>This bit is the Interrupt status of PDMA channel8.</p> <p>Note: This bit is read only</p>
[7]	INTR7	<p><b>Interrupt Pin Status of Channel 7</b> (NuMicro™ NUC100/NUC120 Medium Density Only)</p> <p>This bit is the Interrupt status of PDMA channel7.</p> <p>Note: This bit is read only</p>
[6]	INTR6	<p><b>Interrupt Pin Status of Channel 6</b> (NuMicro™ NUC100/NUC120 Medium Density Only)</p> <p>This bit is the Interrupt status of PDMA channel6.</p> <p>Note: This bit is read only</p>
[5]	INTR5	<p><b>Interrupt Pin Status of Channel 5</b> (NuMicro™ NUC100/NUC120 Medium Density Only)</p> <p>This bit is the Interrupt status of PDMA channel5.</p> <p>Note: This bit is read only</p>



Bits	Descriptions	
[4]	<b>INTR4</b>	<p><b>Interrupt Pin Status of Channel 4</b> (NuMicro™ NUC100/NUC120 Medium Density Only)</p> <p>This bit is the Interrupt status of PDMA channel4.</p> <p>Note: This bit is read only</p>
[3]	<b>INTR3</b>	<p><b>Interrupt Pin Status of Channel 3</b> (NuMicro™ NUC100/NUC120 Medium Density Only)</p> <p>This bit is the Interrupt status of PDMA channel3.</p> <p>Note: This bit is read only</p>
[2]	<b>INTR2</b>	<p><b>Interrupt Pin Status of Channel 2</b> (NuMicro™ NUC100/NUC120 Medium Density Only)</p> <p>This bit is the Interrupt status of PDMA channel2.</p> <p>Note: This bit is read only</p>
[1]	<b>INTR1</b>	<p><b>Interrupt Pin Status of Channel 1</b> (NuMicro™ NUC100/NUC120 Medium Density Only)</p> <p>This bit is the Interrupt status of PDMA channel1.</p> <p>Note: This bit is read only</p>
[0]	<b>INTR0</b>	<p><b>Interrupt Pin Status of Channel 0</b></p> <p>This bit is the Interrupt status of PDMA channel0.</p> <p>Note: This bit is read only</p>



## PDMA Service Selection Control Register 2 (PDMA\_PDSSR2)

Register	Offset	R/W	Description	Reset Value
PDMA_PDSSR2	PDMA_BA_GCR+0x10	R/W	PDMA Service Selection Control Register 2	0x0000_00FF

31	30	29	28	27	26	25	24
Reserved							
23	22	21	20	19	18	17	16
Reserved							
15	14	13	12	11	10	9	8
Reserved							
7	6	5	4	3	2	1	0
I2S_TXSEL				I2S_RXSEL			

Bits	Descriptions	
[31:8]	Reserved	Reserved
[7:4]	I2S_TXSEL	<b>PDMA I<sup>2</sup>S TX Selection</b> This field defines which PDMA channel is connected to the on-chip peripheral I <sup>2</sup> S TX. Software can configure the TX channel setting by I2S_TXSEL. The channel configuration is the same as I2S_RXSEL field. Please refer to the explanation of I2S_RXSEL.
[3:0]	I2S_RXSEL	<b>PDMA I<sup>2</sup>S RX Selection</b> This field defines which PDMA channel is connected to the on-chip peripheral I <sup>2</sup> S RX. Software can change the channel RX setting by I2S_RXSEL.  4'b0000: CH0 4'b0001: CH1 4'b0010: CH2 4'b0011: CH3 4'b0100: CH4 4'b0101: CH5 4'b0110: CH6 4'b0111: CH7 4'b1000: CH8 Others : Reserved  Note: Ex : I2S_RXSEL = 4'b0110, that means I2S_RX is connected to PDMA_CH6



## 5.18 External Bus Interface (EBI)

### 5.18.1 Overview

The NuMicro™ NUC100/NUC120 Low Density LQFP-64 package equips an external bus interface (EBI) for external device used.

To save the connections between external device and this chip, EBI support address bus and data bus multiplex mode. And, address latch enable (ALE) signal supported differentiate the address and data cycle.

### 5.18.2 Features

External Bus Interface has the following functions:

- External devices with max. 64K-byte size (8-bit data width)/128K-byte (16-bit data width) supported
- Variable external bus base clock (MCLK) supported
- 8-bit or 16-bit data width supported
- Variable data access time (tACC), address latch enable time (tALE) and address hold time (tAHD) supported
- Address bus and data bus multiplex mode supported to save the address pins
- Configurable idle cycle supported for different access condition: Write command finish (W2X), Read-to-Read (R2R)

### 5.18.3 Block Diagram

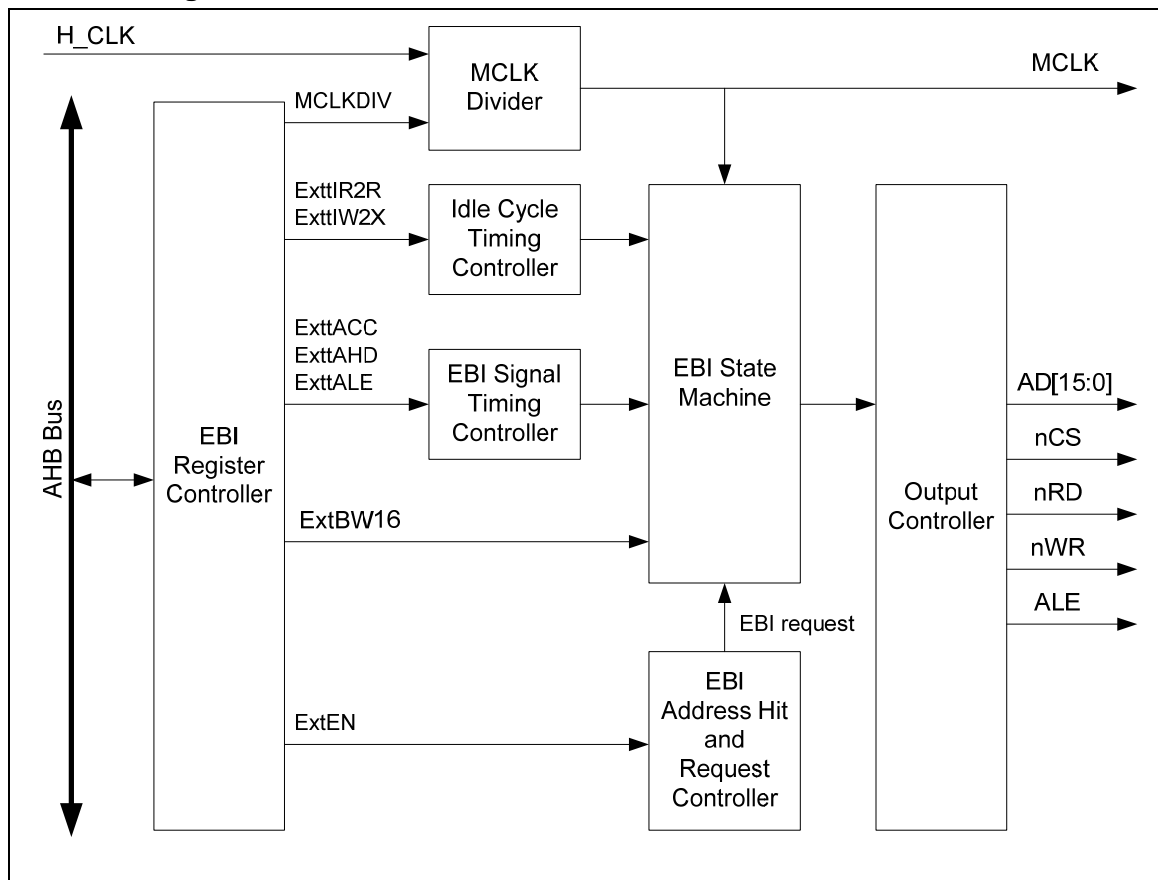

Figure 5-100 EBI Block Diagram

### 5.18.4 Function Description

#### 5.18.4.1 EBI Area and Address Hit

EBI mapping address is located at 0x6000\_0000 ~ 0x6001\_FFFF and the total memory space is 128Kbyte. When system request address hit EBI's memory space, the corresponding EBI chip select signal is assert and EBI state machine operates.

For an 8-bit device (64Kbyte), EBI mapped this 64Kbyte device to 0x6000\_0000 ~ 0x6000\_FFFF and 0x6001\_0000 ~ 0x6001\_FFFF simultaneously.

#### 5.18.4.2 EBI Data Width Connection

EBI support device whose address bus and data bus are multiplexed. For the external device with separated address and data bus, the connection to device needs additional logic to latch the address. In this case, pin ALE is connected to the latch device to latch the address value. Pin AD is the input of the latch device, and the output of the latch device is connected to the address of external device. For 16-bit device, the AD [15:0] shared by address and 16-bit data. For 8-bit device, only AD [7:0] shared by address and 8-bit data, AD [15:8] is dedicated for address and

could be connected to 8-bit device directly.

For 8-bit data width, chip system address bit [15:0] is used as the device's address [15:0]. For 16-bit data width, chip system address bit [16:1] is used as the device's address [15:0] and chip system address bit [0] is useless.

EBI bit width	System address (AHBADR)	EBI address (AD)
8-bit	AHBADR[15:0]	AD[15:0]
16-bit	AHBADR[16:1]	AD[15:0]

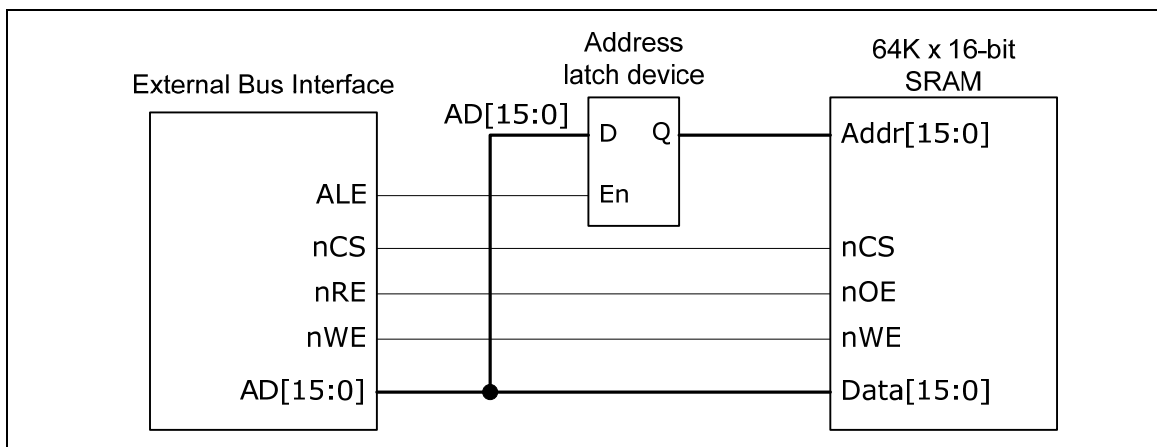

Figure 5-101 Connection of 16-bit EBI Data Width with 16-bit Device

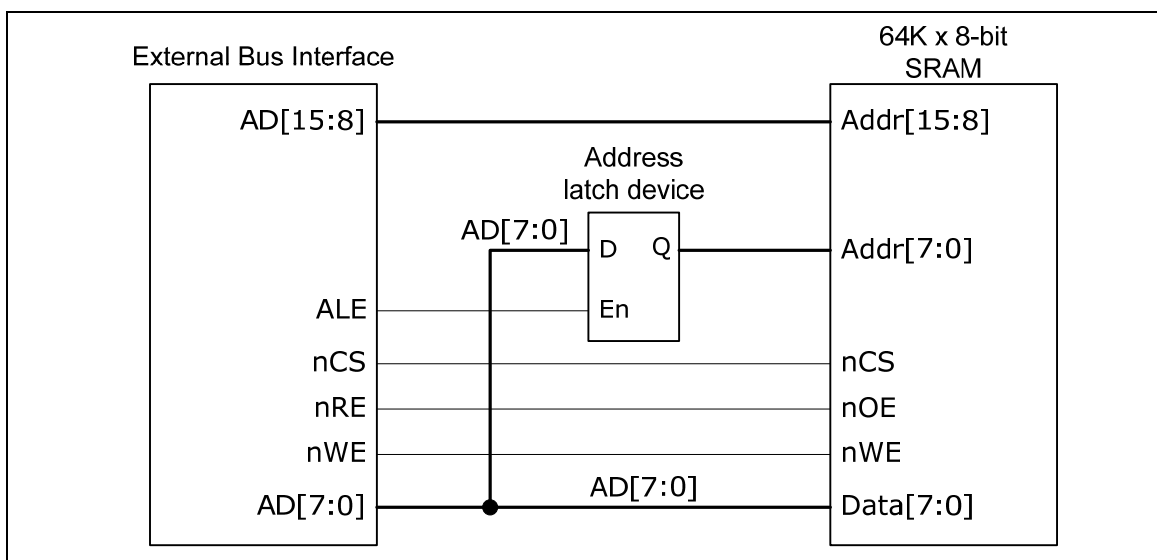

Figure 5-102 Connection of 8-bit EBI Data Width with 8-bit Device

When system access data width is larger than EBI data width, EBI controller will finish a system access command by operating EBI access more than once. For example, if system requests a 32-bit data through EBI device, EBI controller will operate accessing four times when setting EBI



data width with 8-bit.

### 5.18.4.3 EBI Operating Control

#### MCLK Control

In the chip, all EBI signals will be synchronized by MCLK when EBI is operating. When chip connects to the external device with slower operating frequency, the MCLK can divide most to HCLK/32 by setting MCLKDIV of register EBICON. Therefore, chip can suitable for a wide frequency range of EBI device. If MCLK is set to HCLK/1, EBI signals are synchronized by positive edge of MCLK, else by negative edge of MCLK.

#### Operation and Access Timing Control

In the start of access, chip select (nCS) asserts to low and wait one MCLK for address setup time (tASU) for address stable. Then ALE asserts to high after address is stable and keeps for a period of time (tALE) for address latch. After latch address, ALE asserts to low and wait one MCLK for latch hold time (tLHD) and another one MCLK cycle (tA2D) that is inserted behind address hold time to be the bus turn-around time for address change to data. Then nRD asserts to low when read access or nWR asserts to low when write access. Then nRD or nWR asserts to high after keeps access time (tACC) for reading output stable or writing finish. After that, EBI signals keep for data access hold time (tAHD) and chip select asserts to high, address is released by current access control.

EBI controller provides a flexible timing control for different external device. In EBI timing control, tASU, tLHD and tA2D are fixed to 1 MCLK cycle, tAHD can modulate to 1~8 MCLK cycles by setting ExttAHD of register EXTIME, tACC can modulate to 1~32 MCLK cycles by setting ExttACC of register EXTIME, and tALE can modulate to 1~8 MCLK cycles by setting tALE of register EBICON.

Parameter	Value	Unit	Description
tASU	1	MCLK	Address Latch Setup Time.
tALE	1 ~ 8	MCLK	ALE High Period. Controlled by ExttALE of EBICON.
tLHD	1	MCLK	Address Latch Hold Time.
tA2D	1	MCLK	Address To Data Delay (Bus Turn-Around Time).
tACC	1 ~ 32	MCLK	Data Access Time. Controlled by ExttACC of EXTIME.
tAHD	1 ~ 8	MCLK	Data Access Hold Time. Controlled by ExttAHD of EXTIME.
IDLE	0 ~ 15	MCLK	Idle Cycle. Controlled by ExtIR2R and ExtIW2X of EXTIME.

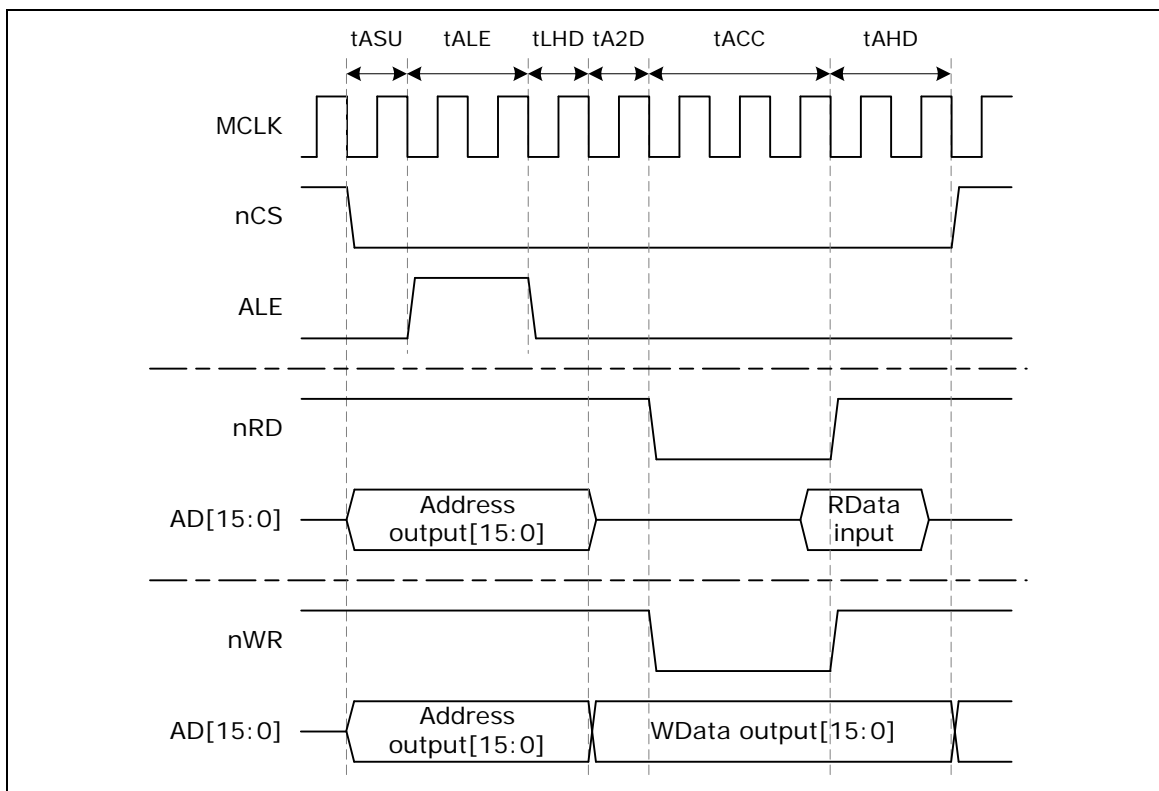

Figure 5-103 Timing Control Waveform for 16-bit Data Width

Figure 5-103 is an example of setting 16-bit data width. In this example, AD bus is used for being address[15:0] and data[15:0]. When ALE asserts to high, AD is address output. After address is latched, ALE asserts to low and the AD bus changes to high impedance to wait device output data in read access operation, or it is used for being write data output.

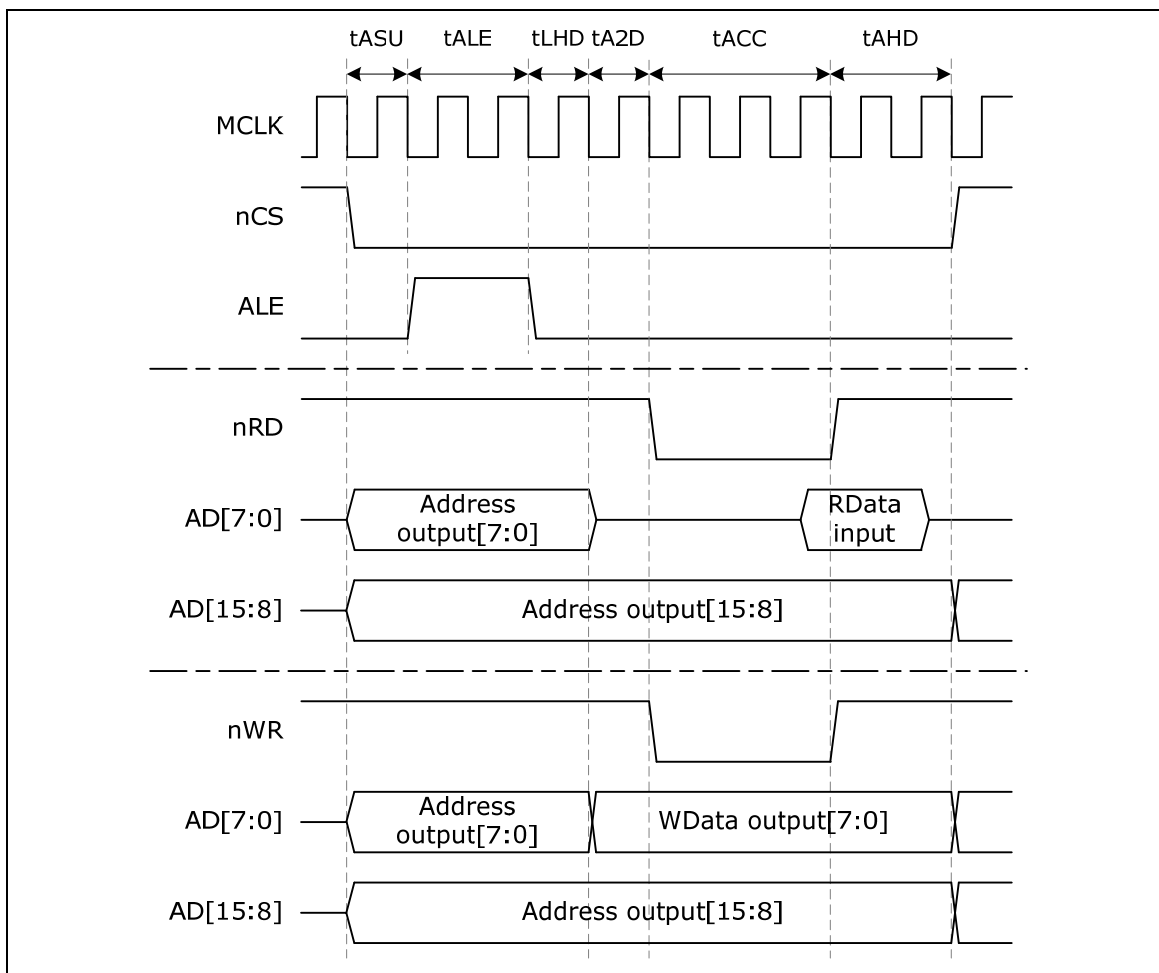

Figure 5-104 Timing Control Waveform for 8-bit Data Width

Figure 5-104 is an example of setting 8-bit data width. The difference between 8-bit and 16-bit data width is AD[15:8]. In 8-bit data width setting, AD[15:8] always be Address[15:8] output so that external latch need only 8-bit width.

## Insert Idle Cycle

When EBI accessing continuously, there may occur bus conflict if the device access time is much slow with system operating. EBI controller supply additional idle cycle to solve this problem. During idle cycle, all control signals of EBI are inactive. Figure 5-105 show idle cycle as below:

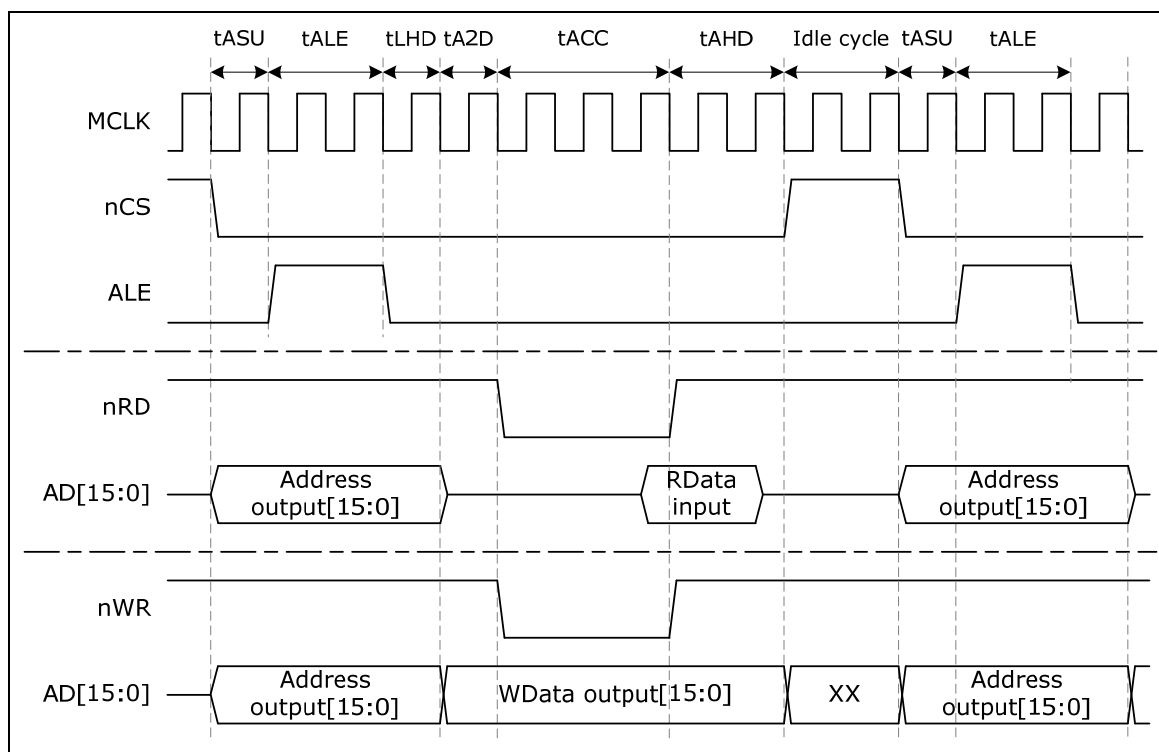

Figure 5-105 Timing Control Waveform for Insert Idle Cycle

There are two conditions that EBI can insert idle cycle by timing control:

1. After write access
2. After read access and before next read access

By setting ExtIW2X, and ExtIR2R of register EXTIME, the time of idle cycle can be specified from 0~15 MCLK.



### 5.18.5 Register Map

R: read only, W: write only, R/W: both read and write

Register	Offset	R/W	Description	Reset Value
<b>EBI_BA = 0x5001_0000</b>				
<b>EBICON</b>	EBI_BA+0x00	R/W	External Bus Interface General Control Register	0x0000_0000
<b>EXTIME</b>	EBI_BA+0x04	R/W	External Bus Interface Timing Control Register	0x0000_0000

### 5.18.6 Register Description

#### External Bus Interface CONTROL REGISTER (EBICON)

Register	Offset	R/W	Description	Reset Value
<b>EBICON</b>	EBI_BA+0x00	R/W	External Bus Interface General Control Register	0x0000_0000

31	30	29	28	27	26	25	24
Reserved							
23	22	21	20	19	18	17	16
Reversed				ExttALE			
15	14	13	12	11	10	9	8
Reversed				MCLKDIV			
7	6	5	4	3	2	1	0
Reversed						ExtBW16	ExtEN

Bits	Descriptions							
[31:19]	Reserved	Reserved						
[18:16]	ExttALE	<b>Expand Time of ALE</b> The ALE width (tALE) to latch the address can be controlled by ExttALE. $tALE = (ExttALE+1)*MCLK$						
[15:11]	Reserved	Reserved						
[10:8]	MCLKDIV	<b>External Output Clock Divider</b> The frequency of EBI output clock is controlled by MCLKDIV as follows table: <table border="1" style="margin-left: 20px;"> <thead> <tr> <th>MCLKDIV</th> <th>Output clock (MCLK)</th> </tr> </thead> <tbody> <tr> <td>000</td> <td>HCLK/1</td> </tr> <tr> <td>001</td> <td>HCLK/2</td> </tr> </tbody> </table>	MCLKDIV	Output clock (MCLK)	000	HCLK/1	001	HCLK/2
MCLKDIV	Output clock (MCLK)							
000	HCLK/1							
001	HCLK/2							





Bits	Descriptions											
		<table border="1" style="width: 100%;"> <tr> <td style="width: 20%;">010</td> <td>HCLK/4</td> </tr> <tr> <td>011</td> <td>HCLK/8</td> </tr> <tr> <td>100</td> <td>HCLK/16</td> </tr> <tr> <td>101</td> <td>HCLK/32</td> </tr> <tr> <td>Others</td> <td>default</td> </tr> </table> <p>Notice: Default value of output clock is HCLK/1</p>	010	HCLK/4	011	HCLK/8	100	HCLK/16	101	HCLK/32	Others	default
010	HCLK/4											
011	HCLK/8											
100	HCLK/16											
101	HCLK/32											
Others	default											
[7:2]	<b>Reserved</b>	Reserved										
[1]	<b>ExtBW16</b>	<p><b>EBI data width 16-bit</b></p> <p>This bit defines if the data bus is 8-bit or 16-bit.</p> <p>1 = EBI data width is 16-bit</p> <p>0 = EBI data width is 8-bit</p>										
[0]	<b>ExtEN</b>	<p><b>EBI Enable</b></p> <p>This bit is the functional enable bit for EBI.</p> <p>1 = EBI function is enabled</p> <p>0 = EBI function is disabled</p>										



**External Bus Interface Timing CONTROL REGISTER (EXTIME)**

Register	Offset	R/W	Description	Reset Value
EXTIME	EBI_BA+0x04	R/W	External Bus Interface Timing Control Register	0x0000_0000

31	30	29	28	27	26	25	24
Reserved				ExtIR2R			
23	22	21	20	19	18	17	16
Reversed							
15	14	13	12	11	10	9	8
ExtIW2X				Reversed	ExttAHD		
7	6	5	4	3	2	1	0
ExttACC					Reversed		

Bits	Descriptions	
[31:28]	Reserved	Reserved
[27:24]	ExtIR2R	<p><b>Idle State Cycle Between Read-Read</b></p> <p>When read action is finish and next action is going to read, idle state is inserted and nCS return to high if ExtIR2R is not zero.</p> <p>Idle state cycle = (ExtIR2R*MCLK)</p>
[23:16]	Reserved	Reserved
[15:12]	ExtIW2X	<p><b>Idle State Cycle After Write</b></p> <p>When write action is finish, idle state is inserted and nCS return to high if ExtIW2X is not zero.</p> <p>Idle state cycle = (ExtIW2X*MCLK)</p>
[11]	Reserved	Reserved
[10:8]	ExttAHD	<p><b>EBI Data Access Hold Time</b></p> <p>ExttAHD define data access hold time (tAHD).</p> <p>tAHD = (ExttAHD + 1) * MCLK</p>
[7:3]	ExttACC	<p><b>EBI Data Access Time</b></p> <p>ExttACC define data access time (tACC).</p> <p>tACC = (ExttACC + 1) * MCLK</p>
[2:0]	Reserved	Reserved



## 6 FLASH MEMORY CONTROLLER (FMC)

### 6.1 Overview

NuMicro™ NUC100 Series equips with 128/64/32K bytes on chip embedded Flash for application program memory (APROM) that can be updated through ISP procedure. In System Programming (ISP) function enables user to update program memory when chip is soldered on PCB. After chip power on, Cortex-M0 CPU fetches code from APROM or LDROM decided by boot select (CBS) in Config0. By the way, NuMicro™ NUC100 Series also provides additional DATA Flash for user, to store some application dependent data before chip power off. For 128K bytes APROM device, the data flash is shared with original 128K program memory and its start address is configurable and defined by user application request in Config1. For 64K/32K bytes APROM device, the data flash is fixed at 4K.

### 6.2 Features

- Run up to 50 MHz with zero wait state for continuous address read access
- 128/64/32KB application program memory (APROM) (NuMicro™ NUC100/NUC120 Low Density only support up to 64KB size)
- 4KB in system programming (ISP) loader program memory (LDROM)
- Configurable or fixed 4KB data flash with 512 bytes page erase unit
- Programmable data flash start address for 128K APROM device
- In System Program (ISP) to update on chip Flash



### 6.3 Block Diagram

The flash memory controller consist of AHB slave interface, ISP control logic, writer interface and flash macro interface timing control logic. The block diagram of flash memory controller is shown as following:

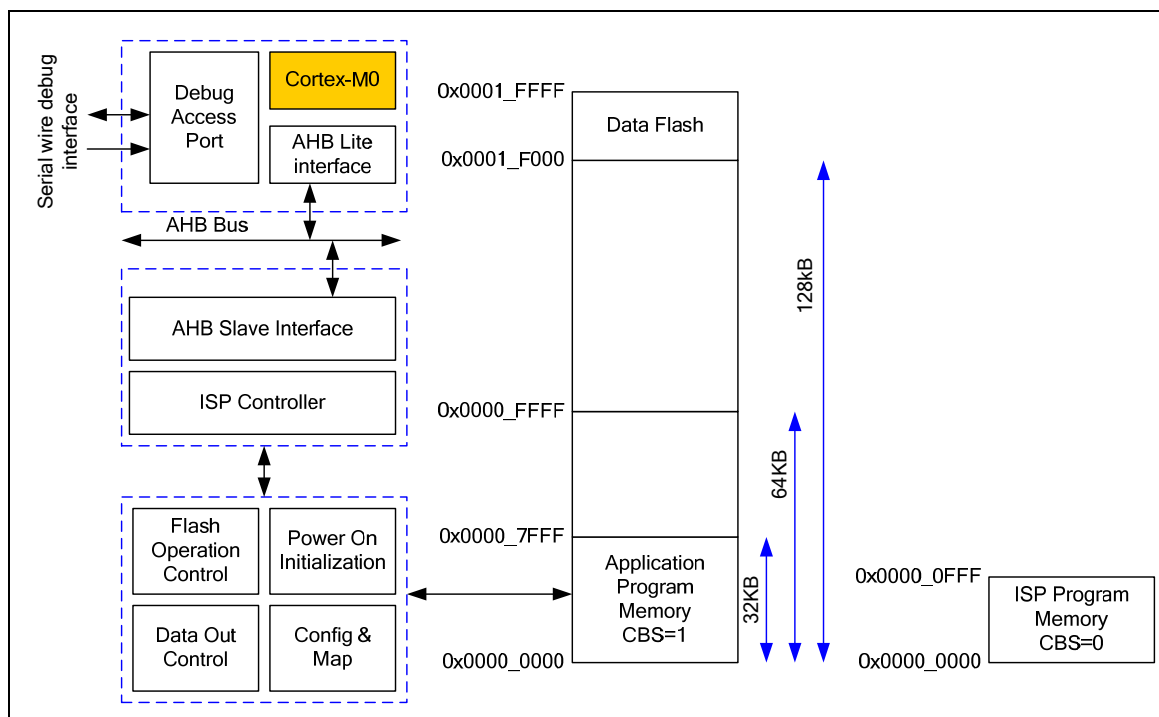

Figure 6-1 NuMicro™ NUC100/NUC120 Medium Density Flash Memory Control Block Diagram

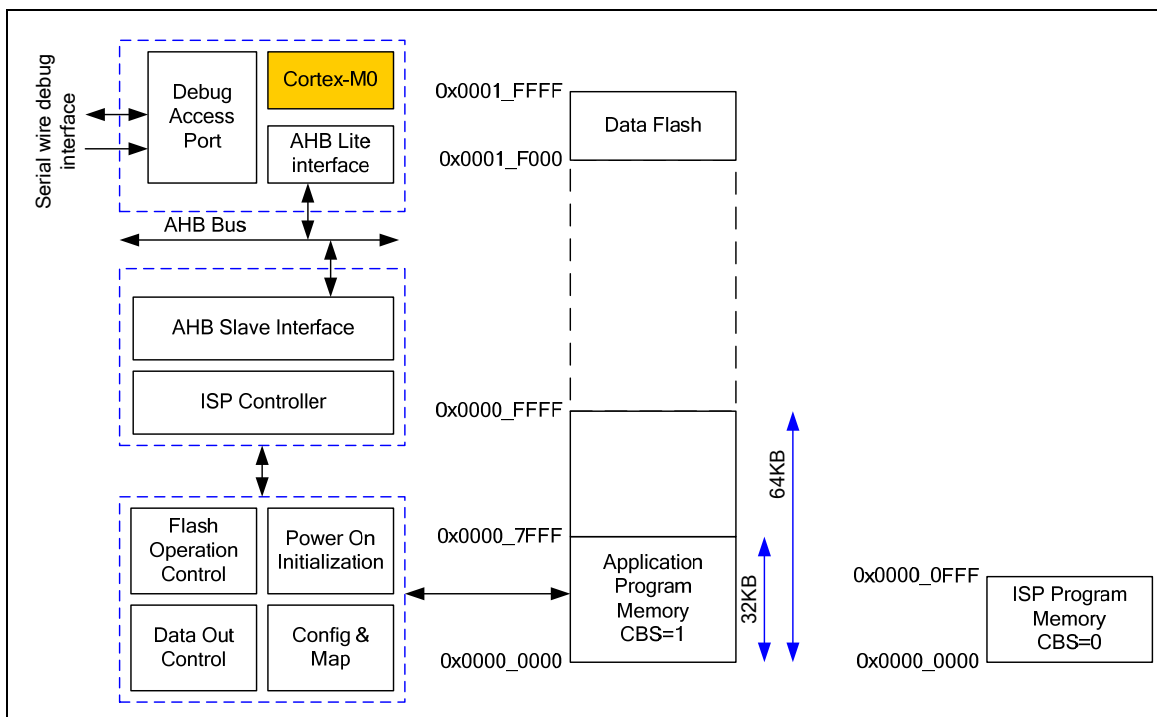

Figure 6-2 NuMicro™ NUC100/NUC120 Low Density Flash Memory Control Block Diagram



## 6.4 Flash Memory Organization

NuMicro™ NUC100 Series flash memory consists of Program memory (128/64/32KB), data flash, ISP loader program memory, user configuration. User configuration block provides several bytes to control system logic, like flash security lock, boot select, Brown-Out voltage level, data flash base address, ..., and so on. It works like a fuse for power on setting. It is loaded from flash memory to its corresponding control registers during chip power on. User can set these bits according to application request by writer before chip is mounted on PCB. The data flash start address and its size can defined by user depends on application in 128KB APROM device. For 64/32KB APROM devices, its size is 4KB and start address is fixed at 0x0001\_F000.

Block Name	Size	Start Address	End Address
AP-ROM	32/64/(128-0.5*N) KB	0x0000_0000	0x0000_7FFF (32KB) 0x0000_FFFF (64KB) DFBADR-1 (128KB if DFEN=0)
Reserved for future use	896KB	0x0002_0000	0x000F_FFFF
Data Flash	4/4/0.5*N KB	0x0001_F000 DFBADR	0x0001_FFFF
LD-ROM	4 KB	0x0010_0000	0x0010_0FFF
User Configuration	2 words	0x0030_0000	0x0030_0004

Table 6-1 NuMicro™ NUC100/NUC120 Medium Density Memory Address Map

Block Name	Size	Start Address	End Address
AP-ROM	32/64KB	0x0000_0000	0x0000_7FFF (32KB) 0x0000_FFFF (64KB)
Reserved for future use	960KB	0x0001_0000	0x000F_FFFF
Data Flash	4 KB	0x0001_F000	0x0001_FFFF
LD-ROM	4 KB	0x0010_0000	0x0010_0FFF
User Configuration	1 words	0x0030_0000	0x0030_0000

Table 6-2 NuMicro™ NUC100/NUC120 Low Density Memory Address Map

The Flash memory organization is shown as below:

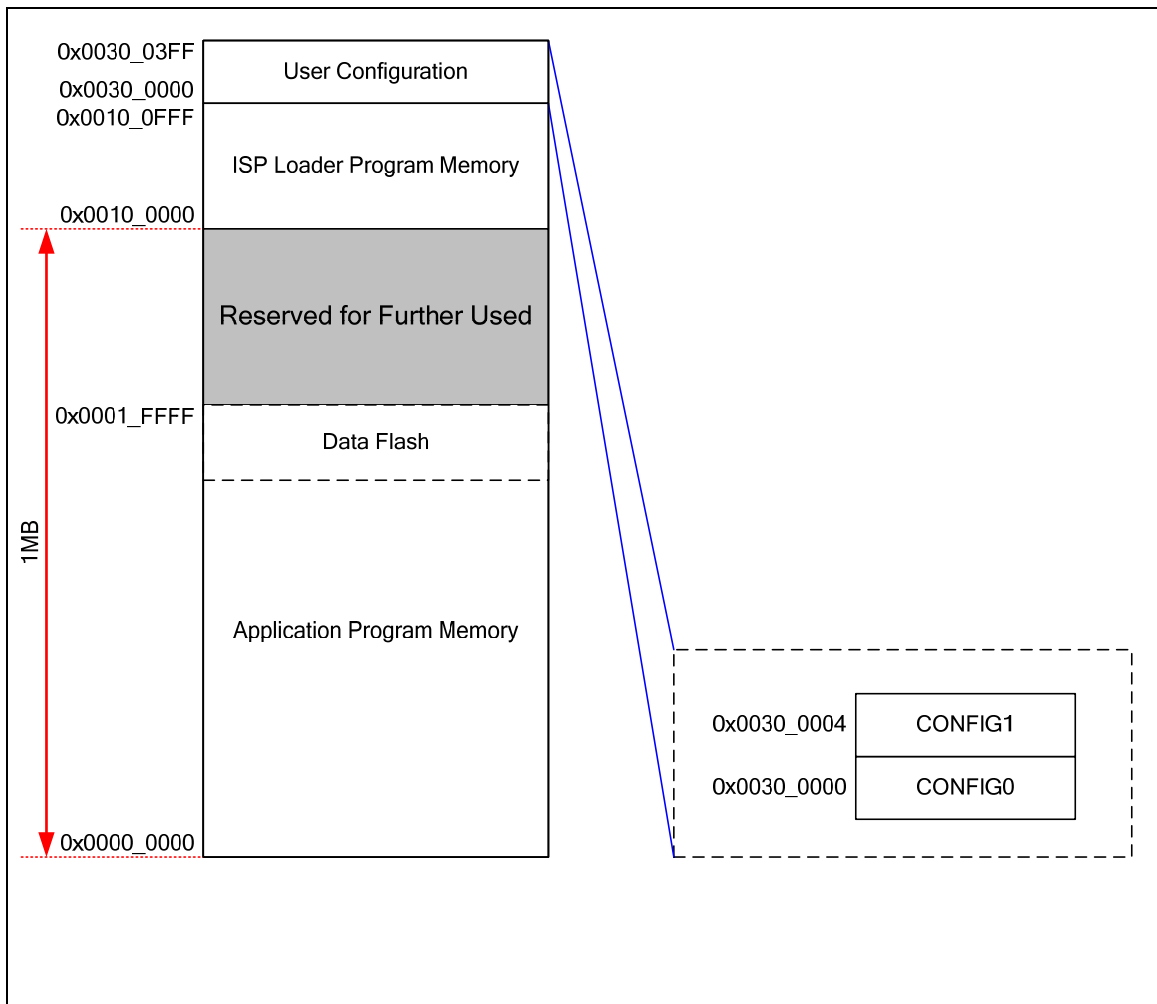

Figure 6-3 NuMicro™ NUC100/NUC120 Medium Density Flash Memory Organization

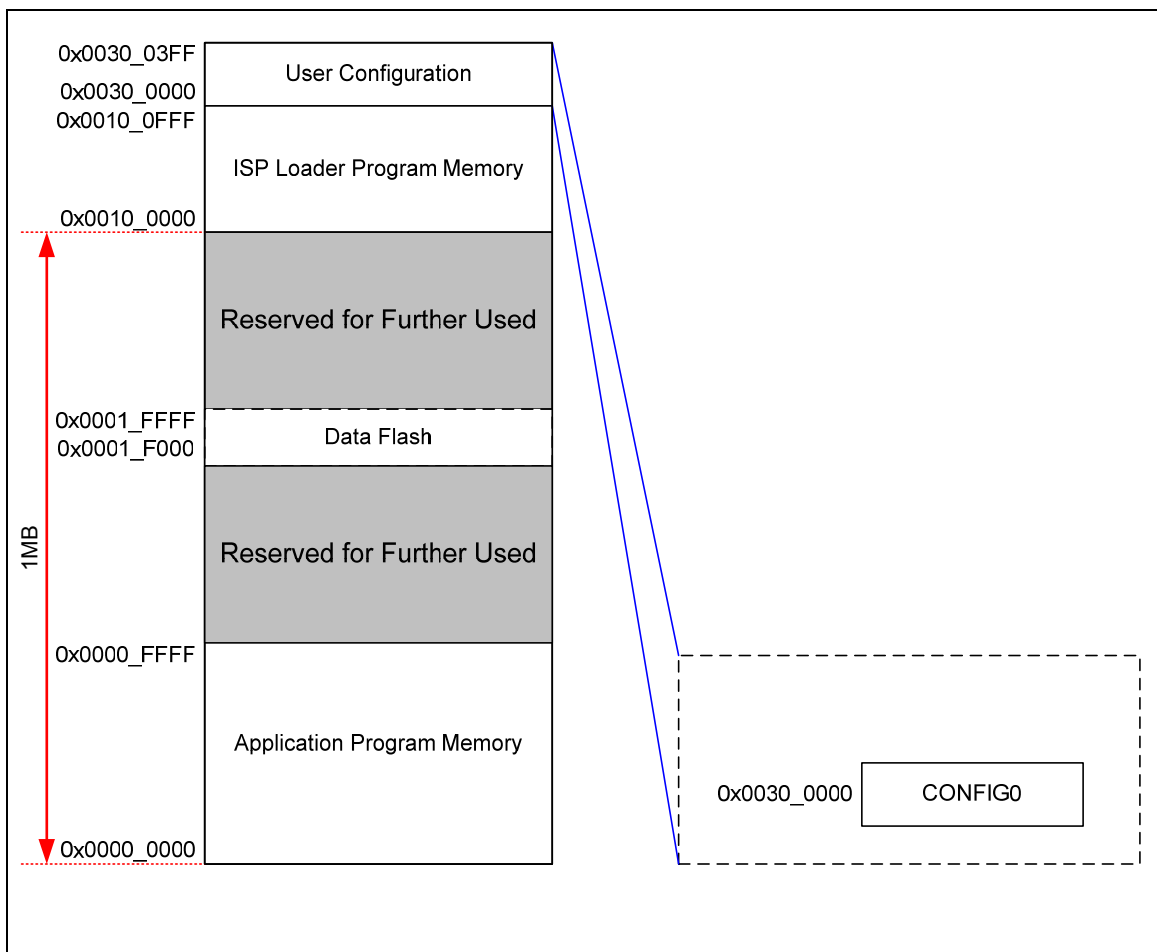

Figure 6-4 NuMicro™ NUC100/NUC120 Low Density Flash Memory Organization





## 6.5 Boot Selection

NuMicro™ NUC100 Series provides in system programming (ISP) feature to enable user to update program memory when chip is mounted on PCB. A dedicated 4KB program memory is used to store ISP firmware. Users can select to start program fetch from APROM or LDROM by (CBS) in Config0.

## 6.6 Data Flash

NuMicro™ NUC100 Series provides data flash for user to store data. It is read/write through ISP procedure. The size of each erase unit is 512 bytes. When a word will be changed, all 128 words need to be copied to another page or SRAM in advance. For 128KB APROM device, the data flash and application program share the same 128KB memory, if DFEN bit in Config0 is enabled, the data flash base address is defined by DFBADR and application program memory size is  $(128 - 0.5 * N) \text{KB}$  and data flash size is  $0.5 * N \text{KB}$ . For 64/32KB APROM devices, data flash size is 4KB and start address is fixed at  $0x0001\_F000$ .

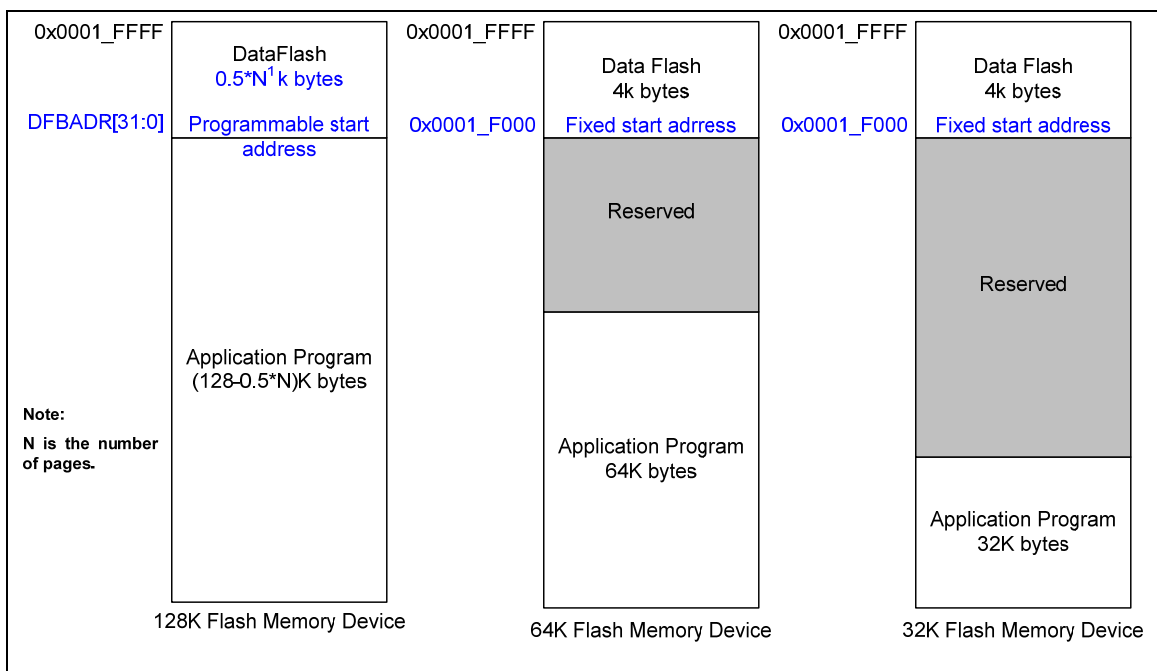

Figure 6-5 NuMicro™ NUC100/NUC120 Medium Density Flash Memory Structure

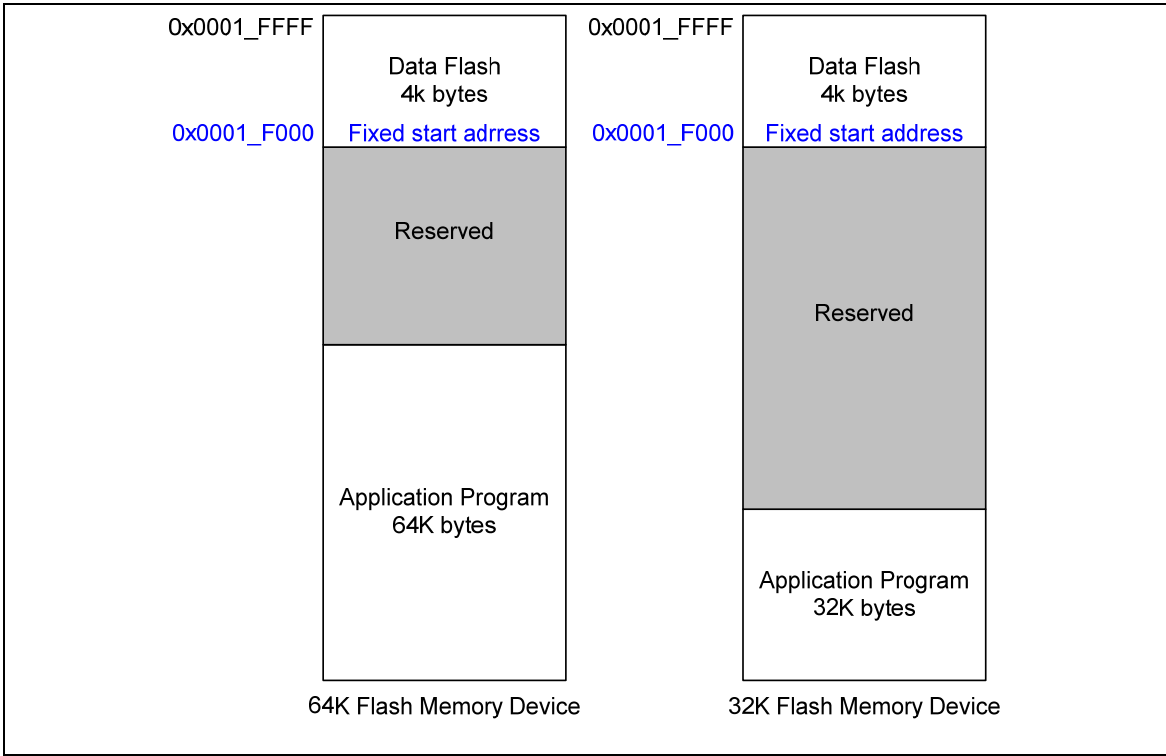

Figure 6-6 NuMicro™ NUC100/NUC120 Low Density Flash Memory Structure



## 6.7 User Configuration

**Config0 (Address = 0x0030\_0000)**

31	30	29	28	27	26	25	24
Reserved			CKF	Reserved	CFOSC		
23	22	21	20	19	18	17	16
CBODEN	CBOV1	CBOV0	CBORST	Reserved			
15	14	13	12	11	10	9	8
Reserved							
7	6	5	4	3	2	1	0
CBS	Reserved					LOCK	DFEN

Bits	Descriptions																
[31:29]	Reserved	Reserved															
[28]	CKF	<b>XT1 Clock Filter Enable</b> 0 = Disable XT1 clock filter 1 = Enable XT1 clock filter															
[27]	Reserved	Reserved															
[26:24]	CFOSC	<b>CPU Clock Source Selection After Reset</b>															
		<table border="1"> <thead> <tr> <th>FOSC[2:0]</th><th>Clock Source</th></tr> </thead> <tbody> <tr> <td>000</td><td>External 4~24 MHz high speed crystal clock</td></tr> <tr> <td>111</td><td>Internal 22.1184 MHz high speed oscillator clock</td></tr> <tr> <td>Others</td><td>Reserved</td></tr> </tbody> </table>	FOSC[2:0]	Clock Source	000	External 4~24 MHz high speed crystal clock	111	Internal 22.1184 MHz high speed oscillator clock	Others	Reserved							
		FOSC[2:0]	Clock Source														
		000	External 4~24 MHz high speed crystal clock														
111	Internal 22.1184 MHz high speed oscillator clock																
Others	Reserved																
The value of CFOSC will be load to CLKSEL0.HCLK_S[2:0] in system register after any reset occurs.																	
[23]	CBODEN	<b>Brown-Out Detector Enable</b> 0= Enable Brown-Out detect after power on 1= Disable Brown-Out detect after power on															
[22:21]	CBOV1-0	<b>Brown-Out Voltage Selection</b>															
		<table border="1"> <thead> <tr> <th>CBOV1</th><th>CBOV0</th><th>Brown-Out voltage</th></tr> </thead> <tbody> <tr> <td>1</td><td>1</td><td>4.5 V</td></tr> <tr> <td>1</td><td>0</td><td>3.8 V</td></tr> <tr> <td>0</td><td>1</td><td>2.7 V</td></tr> <tr> <td>0</td><td>0</td><td>2.2 V</td></tr> </tbody> </table>	CBOV1	CBOV0	Brown-Out voltage	1	1	4.5 V	1	0	3.8 V	0	1	2.7 V	0	0	2.2 V
		CBOV1	CBOV0	Brown-Out voltage													
		1	1	4.5 V													
		1	0	3.8 V													
0	1	2.7 V															
0	0	2.2 V															



Bits	Descriptions	
[20]	<b>CBORST</b>	<b>Brown-Out Reset Enable</b> 0 = Enable Brown-Out reset after power on 1 = Disable Brown-Out reset after power on
[19:8]	<b>Reserved</b>	Reserved
[7]	<b>CBS</b>	<b>Chip Boot Selection</b> 0 = Chip boot from LDR0M 1 = Chip boot from APROM
[6:2]	<b>Reserved</b>	Reserved
[1]	<b>LOCK</b>	<b>Security Lock</b> 0 = Flash data is locked 1 = Flash data is not locked  When flash data is locked, only device ID, Config0 and Config1 can be read by writer and ICP through serial debug interface. Others data is locked as 0xFFFFFFFF. ISP can read data anywhere regardless of LOCK bit value.
[0]	<b>DFEN</b>	<b>Data Flash Enable</b> (This bit is work only for 128KB APROM device) 0 = Enable data flash 1 = Disable data flash



**Config1 (Address = 0x0030 0004)**

31	30	29	28	27	26	25	24
Reserved							
23	22	21	20	19	18	17	16
Reserved				DFBADR.19	DFBADR.18	DFBADR.17	DFBADR.16
15	14	13	12	11	10	9	8
DFBADR.15	DFBADR.14	DFBADR.13	DFBADR.12	DFBADR.11	DFBADR.10	DFBADR.9	DFBADR.8
7	6	5	4	3	2	1	0
DFBADR.7	DFBADR.6	DFBADR.5	DFBADR.4	DFBADR.3	DFBADR.2	DFBADR.1	DFBADR.0

Bits	Descriptions	
[31:20]	<b>Reserved</b>	Reserved (It is mandatory to program 0x00 to these Reserved bits)
[19:0]	<b>DFBADR</b>	<p><b>Data Flash Base Address</b> (This register is work only for 128KB APROM device)</p> <p>For 128KB APROM device, its data flash base address is defined by user. Since on chip flash erase unit is 512 bytes, it is mandatory to keep bit 8-0 as 0. This configuration is only valid for 128KB flash device.</p>

## 6.8 In System Program (ISP)

The program memory and data flash supports both in hardware programming and in system programming (ISP). Hardware programming mode uses gang-writers to reduce programming costs and time to market while the products enter into the mass production state. However, if the product is just under development or the end product needs firmware updating in the hand of an end user, the hardware programming mode will make repeated programming difficult and inconvenient. ISP method makes it easy and possible. NuMicro™ NUC100 Series supports ISP mode allowing a device to be reprogrammed under software control. Furthermore, the capability to update the application firmware makes wide range of applications possible.

ISP is performed without removing the microcontroller from the system. Various interfaces enable LDROM firmware to get new program code easily. The most common method to perform ISP is via UART along with the firmware in LDROM. General speaking, PC transfers the new APROM code through serial port. Then LDROM firmware receives it and re-programs into APROM through ISP commands. Nuvoton provides ISP firmware and PC application program for NuMicro™ NUC100 Series. It makes users quite easy perform ISP through Nuvoton ISP tool.

### 6.8.1 ISP Procedure

NuMicro™ NUC100 Series supports booting from APROM or LDROM initially defined by user configuration bit (CBS). If user wants to update application program in APROM, he can write BS=1 and starts software reset to make chip boot from LDROM. The first step to start ISP function is write ISPEN bit to 1. S/W is required to write REGWRPROT register in Global Control Register (GCR, 0x5000\_0100) with 0x59, 0x16 and 0x88 before writing ISPCON register. This procedure is used to protect flash memory from destroying owing to unintended write during power on/off duration.

Several error conditions are checked after software writes ISPGO bit. If error condition occurs, ISP operation is not been started and ISP fail flag will be set instead of. ISPPFF flag is cleared by s/w, it will not be over written in next ISP operation. The next ISP procedure can be started even ISPPFF bit keeps at 1. It is recommended that s/w to check ISPPFF bit and clear it after each ISP operation if it is set to 1.

When ISPGO bit is set, CPU will wait for ISP operation finish, during this period; peripheral still keeps working as usual. If any interrupt request occur, CPU will not service it till ISP operation finish. When ISP operation is finished, the ISPGO bit will be cleared by hardware automatically. User can know if ISP operation is finished by checking this bit. User should add ISB instruction next to the instruction which set 1 to ISPGO bit to ensure correct execution of the instructions following ISP operation.

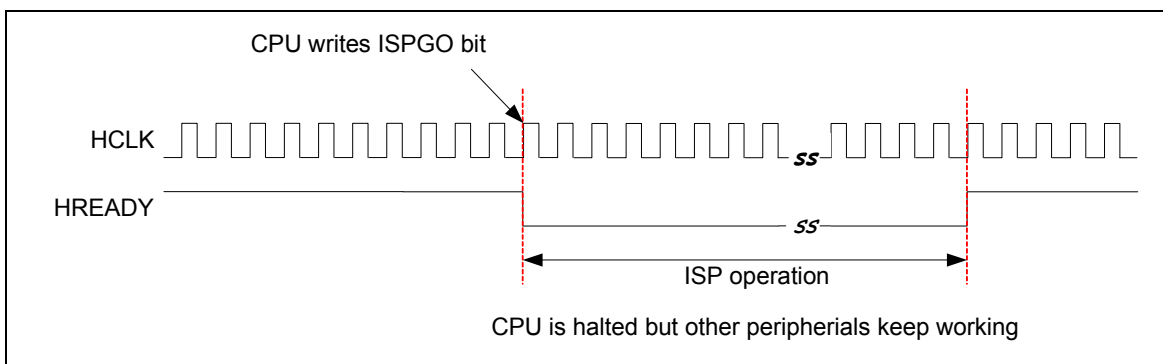

Note that NuMicro™ NUC100 Series allows user to update CONFIG value by ISP.

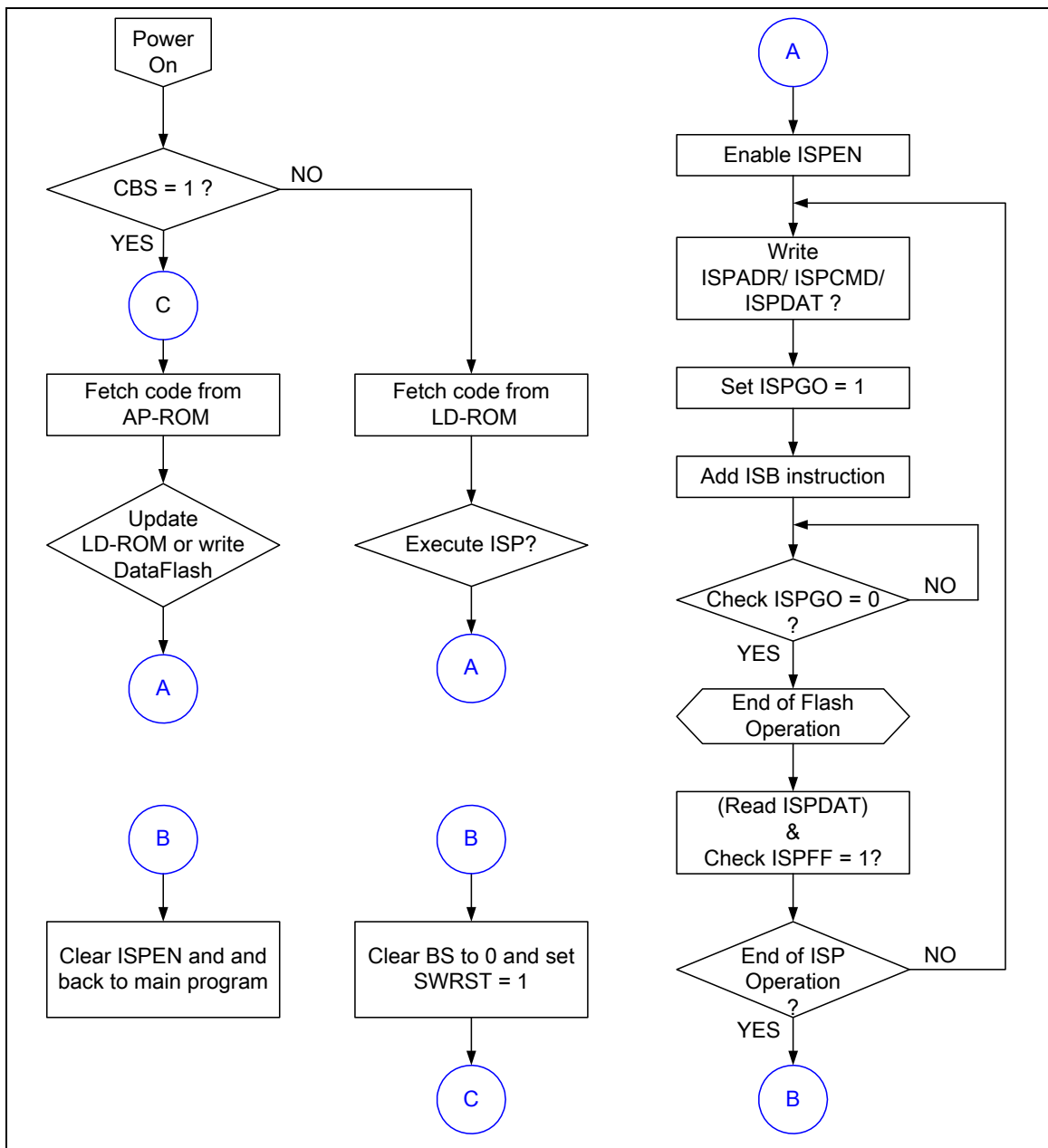



ISP Mode	ISPCMD			ISPADR			ISPDAT
	FOEN	FCEN	FCTRL[3:0]	A21	A20	A[19:0]	D[31:0]
FLASH Page Erase	1	0	0010	0	A20	Address in A[19:0]	x
FLASH Program	1	0	0001	0	A20	Address in A[19:0]	Data in D[31:0]
FLASH Read	0	0	0000	0	A20	Address in A[19:0]	Data out D[31:0]
CONFIG Page Erase	1	0	0010	1	1	Address in A[19:0]	x
CONFIG Program	1	0	0001	1	1	Address in A[19:0]	Data in D[31:0]
CONFIG Read	0	0	0000	1	1	Address in A[19:0]	Data out D[31:0]

Table 6-3 ISP Mode





## 6.9 Flash Control Register Map

R: read only, W: write only, R/W: both read and write

Register	Offset	R/W	Description	Reset Value
<b>Base Address (FMC_BA) : 0x5000_C000</b>				
<b>ISPCON</b>	FMC_BA+0x00	R/W	ISP Control Register	0x0000_0000
<b>ISPADR</b>	FMC_BA+0x04	R/W	ISP Address Register	0x0000_0000
<b>ISPDAT</b>	FMC_BA+0x08	R/W	ISP Data Register	0x0000_0000
<b>ISPCMD</b>	FMC_BA+0x0C	R/W	ISP Command Register	0x0000_0000
<b>ISPTRG</b>	FMC_BA+0x10	R/W	ISP Trigger Register	0x0000_0000
<b>DFBADR</b>	FMC_BA+0x14	R	Data Flash Start Address (AP ROM size is less than 128KB)	0x0001_F000
<b>DFBADR</b>	FMC_BA+0x14	R	Data Flash Start Address (AP ROM size is equal to 128KB)	0x0000_0000
<b>FATCON</b>	FMC_BA+0x18	R/W	Flash Access Window Control Register	0x0000_0000



### 6.10 Flash Control Register Description

#### ISP Control Register (ISPCON)

Register	Offset	R/W	Description	Reset Value
ISPCON	FMC_BA+0x00	R/W	ISP Control Register	0x0000_0000

31	30	29	28	27	26	25	24
Reserved							
23	22	21	20	19	18	17	16
Reserved							
15	14	13	12	11	10	9	8
Reserved	ET			Reserved	PT		
7	6	5	4	3	2	1	0
Reserved	ISPPF	LDUEN	CFGUEN	Reserved		BS	ISPEN

Bits	Descriptions																																					
[31:15]	Reserved	Reserved																																				
[14:12]	ET[2:0]	Flash Erase Time (write-protection bits)																																				
		<table border="1"> <thead> <tr> <th>ET[2]</th> <th>ET[1]</th> <th>ET[0]</th> <th>Erase Time (ms)</th> </tr> </thead> <tbody> <tr> <td>0</td> <td>0</td> <td>0</td> <td>20 (default)</td> </tr> <tr> <td>0</td> <td>0</td> <td>1</td> <td>25</td> </tr> <tr> <td>0</td> <td>1</td> <td>0</td> <td>30</td> </tr> <tr> <td>0</td> <td>1</td> <td>1</td> <td>35</td> </tr> <tr> <td>1</td> <td>0</td> <td>0</td> <td>3</td> </tr> <tr> <td>1</td> <td>0</td> <td>1</td> <td>5</td> </tr> <tr> <td>1</td> <td>1</td> <td>0</td> <td>10</td> </tr> <tr> <td>1</td> <td>1</td> <td>1</td> <td>15</td> </tr> </tbody> </table>	ET[2]	ET[1]	ET[0]	Erase Time (ms)	0	0	0	20 (default)	0	0	1	25	0	1	0	30	0	1	1	35	1	0	0	3	1	0	1	5	1	1	0	10	1	1	1	15
		ET[2]	ET[1]	ET[0]	Erase Time (ms)																																	
		0	0	0	20 (default)																																	
		0	0	1	25																																	
		0	1	0	30																																	
		0	1	1	35																																	
		1	0	0	3																																	
		1	0	1	5																																	
1	1	0	10																																			
1	1	1	15																																			
[11]	Reserved	Reserved																																				



Bits	Descriptions																																					
[8:10]	PT[2:0]	<b>Flash Program Time</b> (write-protection bits) <table border="1"> <thead> <tr> <th>PT[2]</th> <th>PT[1]</th> <th>PT[0]</th> <th>Program Time (us)</th> </tr> </thead> <tbody> <tr> <td>0</td> <td>0</td> <td>0</td> <td>40</td> </tr> <tr> <td>0</td> <td>0</td> <td>1</td> <td>45</td> </tr> <tr> <td>0</td> <td>1</td> <td>0</td> <td>50</td> </tr> <tr> <td>0</td> <td>1</td> <td>1</td> <td>55</td> </tr> <tr> <td>1</td> <td>0</td> <td>0</td> <td>20</td> </tr> <tr> <td>1</td> <td>0</td> <td>1</td> <td>25</td> </tr> <tr> <td>1</td> <td>1</td> <td>0</td> <td>30</td> </tr> <tr> <td>1</td> <td>1</td> <td>1</td> <td>35</td> </tr> </tbody> </table>	PT[2]	PT[1]	PT[0]	Program Time (us)	0	0	0	40	0	0	1	45	0	1	0	50	0	1	1	55	1	0	0	20	1	0	1	25	1	1	0	30	1	1	1	35
		PT[2]	PT[1]	PT[0]	Program Time (us)																																	
		0	0	0	40																																	
		0	0	1	45																																	
		0	1	0	50																																	
		0	1	1	55																																	
		1	0	0	20																																	
		1	0	1	25																																	
		1	1	0	30																																	
		1	1	1	35																																	
[7]	Reserved	Reserved																																				
[6]	ISPPF	<b>ISP Fail Flag</b> (write-protection bit) This bit is set by hardware when a triggered ISP meets any of the following conditions: (1) APROM writes to itself (2) LDROM writes to itself (3) CONFIG is erased/programmed if CFGUEN is set to 0 (4) Destination address is illegal, such as over an available range Write 1 to clear.																																				
[5]	LDUEN	<b>LDROM Update Enable</b> (write-protection bit) LDROM update enable bit. 1 = LDROM can be updated when the chip runs in APROM 0 = LDROM can not be updated																																				
[4]	CFGUEN	<b>Enable Config-bits Update by ISP</b> (write-protection bit) 1 = Enable ISP can update config-bits 0 = Disable ISP can update config-bits																																				
[3:2]	Reserved	Reserved																																				
[1]	BS	<b>Boot Select</b> (write-protection bit) Set/clear this bit to select next booting from LDROM/APROM, respectively. This bit also functions as chip booting status flag, which can be used to check where chip booted from. This bit is initiated with the inversed value of CBS in Config0 after any reset is happened except CPU reset (RSTS_CPU is 1) or system reset (RSTS_SYS) is happened 1 = boot from LDROM 0 = boot from APROM																																				
[0]	ISPEN	<b>ISP Enable</b> (write-protection bit) ISP function enable bit. Set this bit to enable ISP function. 1 = Enable ISP function 0 = Disable ISP function																																				





## ISP Address (ISPADR)

Register	Offset	R/W	Description	Reset Value
ISPADR	FMC_BA+0x04	R/W	ISP Address Register	0x0000_0000

31	30	29	28	27	26	25	24
ISPADR[31:24]							
23	22	21	20	19	18	17	16
ISPADR[23:16]							
15	14	13	12	11	10	9	8
ISPADR[15:8]							
7	6	5	4	3	2	1	0
ISPADR[7:0]							

Bits	Descriptions	
[31:0]	<b>ISPADR</b>	<b>ISP Address</b> NuMicro™ NUC100 Series equips with a maximum 32Kx32 embedded flash, it supports word program only. ISPADR[1:0] must be kept 00b for ISP operation.



## ISP Data Register (ISPDAT)

Register	Offset	R/W	Description	Reset Value
ISPDAT	FMC_BA+0x08	R/W	ISP Data Register	0x0000_0000

31	30	29	28	27	26	25	24
ISPDAT[31:24]							
23	22	21	20	19	18	17	16
ISPDAT [23:16]							
15	14	13	12	11	10	9	8
ISPDAT [15:8]							
7	6	5	4	3	2	1	0
ISPDAT [7:0]							

Bits	Descriptions	
[31:0]	<b>ISPDAT</b>	<p><b>ISP Data</b></p> <p>Write data to this register before ISP program operation</p> <p>Read data from this register after ISP read operation</p>



## ISP Command (ISPCMD)

Register	Offset	R/W	Description	Reset Value
ISPCMD	FMC_BA+0x0C	R/W	ISP Command Register	0x0000_0000

31	30	29	28	27	26	25	24
Reserved							
23	22	21	20	19	18	17	16
Reserved							
15	14	13	12	11	10	9	8
Reserved							
7	6	5	4	3	2	1	0
Reserved		FOEN	FCEN	FCTRL			

Bits	Descriptions						
[31:6]	Reserved	Reserved					
[5]	FOEN	<b>ISP Command</b> ISP command table is showed below:					
[4]	FCEN	Operation Mode	FOEN	FCEN	FCTRL[3:0]		
		Read	0	0	0	0	0
[3:0]	FCTRL	Program	1	0	0	0	1
		Page Erase	1	0	0	0	1



## ISP Trigger Control Register (ISPTRG)

Register	Offset	R/W	Description	Reset Value
ISPTRG	FMC_BA+0x10	R/W	ISP Trigger Control Register	0x0000_0000

31	30	29	28	27	26	25	24
Reserved							
23	22	21	20	19	18	17	16
Reserved							
15	14	13	12	11	10	9	8
Reserved							
7	6	5	4	3	2	1	0
Reserved							ISPGO

Bits	Descriptions	
[31:1]	Reserved	Reserved
[0]	ISPGO	<p><b>ISP start trigger</b> (write-protection bit)</p> <p>Write 1 to start ISP operation and this bit will be cleared to 0 by hardware automatically when ISP operation is finished.</p> <p>1 = ISP is on going</p> <p>0 = ISP operation is finished</p> <p>This bit is the protected bit, It means programming this bit needs to write "59h", "16h", "88h" to address 0x5000_0100 to disable register protection. Reference the register REGWRPROT at address GCR_BA+0x100</p>





**Data Flash Base Address Register (DFBADR)**

Register	Offset	R/W	Description	Reset Value
DFBADR	FMC_BA+0x14	R	Data flash Base Address	0x0001_F000

31	30	29	28	27	26	25	24
DFBADR[31:23]							
23	22	21	20	19	18	17	16
DFBADR[23:16]							
15	14	13	12	11	10	9	8
DFBADR[15:8]							
7	6	5	4	3	2	1	0
DFBADR[7:0]							

Bits	Descriptions	
[31:0]	<b>DFBADR</b>	<p><b>Data Flash Base Address</b></p> <p>This register indicates data flash start address. It is a read only register.</p> <p>For 128KB flash memory device, the data flash size is defined by user configuration, register content is loaded from Config1 when chip power on but for 64/32KB device, it is fixed at 0x0001_F000.</p>



## Flash Access Time Control Register (FATCON)

Register	Offset	R/W	Description	Reset Value
FATCON	FMC_BA+0x18	R/W	Flash Access Time Control Register	0x0000_0000

31	30	29	28	27	26	25	24
Reserved							
23	22	21	20	19	18	17	16
Reserved							
15	14	13	12	11	10	9	8
Reserved							
7	6	5	4	3	2	1	0
Reserved			LFOM	FATS[2:0]			FPSEN

Bits	Descriptions																			
[31:5]	Reserved	Reserved																		
[4]	LFOM	<p><b>Low Frequency Optimization Mode</b> (write-protection bit)</p> <p>When chip operation frequency is lower than 25 MHz, chip can work more efficiently by setting this bit to 1</p> <p>1 = Enable low frequency optimization mode</p> <p>0 = Disable low frequency optimization mode</p> <p>(This bit is only for NuMicro™ NUC100/NUC120 Low Density)</p>																		
[3:1]	FATS	<p><b>Flash Access Time Window Select</b> (write-protection bits)</p> <p>These bits are used to decide flash sense amplifier active duration.</p> <table border="1" style="margin-left: 20px;"> <thead> <tr> <th>FATS</th> <th>Access Time window (ns)</th> </tr> </thead> <tbody> <tr><td>000</td><td>40</td></tr> <tr><td>001</td><td>50</td></tr> <tr><td>010</td><td>60</td></tr> <tr><td>011</td><td>70</td></tr> <tr><td>100</td><td>80</td></tr> <tr><td>101</td><td>90</td></tr> <tr><td>110</td><td>100</td></tr> <tr><td>111</td><td>Reserved</td></tr> </tbody> </table>	FATS	Access Time window (ns)	000	40	001	50	010	60	011	70	100	80	101	90	110	100	111	Reserved
FATS	Access Time window (ns)																			
000	40																			
001	50																			
010	60																			
011	70																			
100	80																			
101	90																			
110	100																			
111	Reserved																			



Bits	Descriptions	
[0]	<b>FPSEN</b>	<b>Flash Power Save Enable</b> (write-protection bit) If CPU clock is slower than 24 MHz, then s/w can enable flash power saving function. 1 = Enable flash power saving 0 = Disable flash power saving

## 7 ELECTRICAL CHARACTERISTICS

### 7.1 Absolute Maximum Ratings

SYMBOL	PARAMETER	MIN	MAX	UNIT
DC Power Supply	$V_{DD}-V_{SS}$	-0.3	+7.0	V
Input Voltage	$V_{IN}$	$V_{SS}-0.3$	$V_{DD}+0.3$	V
Oscillator Frequency	$1/t_{CLCL}$	4	24	MHz
Operating Temperature	$T_A$	-40	+85	°C
Storage Temperature	$T_{ST}$	-55	+150	°C
Maximum Current into $V_{DD}$		-	120	mA
Maximum Current out of $V_{SS}$			120	mA
Maximum Current sunk by a I/O pin			35	mA
Maximum Current sourced by a I/O pin			35	mA
Maximum Current sunk by total I/O pins			100	mA
Maximum Current sourced by total I/O pins			100	mA

Note: Exposure to conditions beyond those listed under absolute maximum ratings may adversely affects the life and reliability of the device.



## 7.2 DC Electrical Characteristics

### 7.2.1 NuMicro™ NUC100/NUC120 Medium Density DC Electrical Characteristics

( $V_{DD}-V_{SS}=3.3\text{ V}$ ,  $T_A = 25^\circ\text{C}$ ,  $F_{OSC} = 50\text{ MHz}$  unless otherwise specified.)

PARAMETER	SYM.	SPECIFICATION				TEST CONDITIONS
		MIN.	TYP.	MAX.	UNIT	
Operation voltage	$V_{DD}$	2.5		5.5	V	$V_{DD} = 2.5\text{ V} \sim 5.5\text{ V}$ up to 50 MHz
Power Ground	$V_{SS}$ $AV_{SS}$	-0.3			V	
LDO Output Voltage	$V_{LDO}$	-10%	2.5	+10%	V	$V_{DD} > 2.7\text{ V}$
Analog Operating Voltage	$AV_{DD}$	0		$V_{DD}$	V	
Analog Reference Voltage	$V_{ref}$	0		$AV_{DD}$	V	
Operating Current Normal Run Mode @ 50 MHz	$I_{DD1}$		54		mA	$V_{DD} = 5.5\text{ V}@50\text{ MHz}$ , enable all IP and PLL, XTAL=12 MHz
	$I_{DD2}$		31		mA	$V_{DD} = 5.5\text{ V}@50\text{ MHz}$ , disable all IP and enable PLL, XTAL=12 MHz
	$I_{DD3}$		51		mA	$V_{DD} = 3\text{ V}@50\text{ MHz}$ , enable all IP and PLL, XTAL=12 MHz
	$I_{DD4}$		28		mA	$V_{DD} = 3\text{ V}@50\text{ MHz}$ , disable all IP and enable PLL, XTAL=12 MHz
Operating Current Normal Run Mode @ 12 MHz	$I_{DD5}$		22		mA	$V_{DD} = 5.5\text{ V}@12\text{ MHz}$ , enable all IP and disable PLL, XTAL=12 MHz
	$I_{DD6}$		14		mA	$V_{DD} = 5.5\text{ V}@12\text{ MHz}$ , disable all IP and disable PLL, XTAL=12 MHz
	$I_{DD7}$		20		mA	$V_{DD} = 3\text{ V}@12\text{ MHz}$ , enable all IP and disable PLL, XTAL=12 MHz



PARAMETER	SYM.	SPECIFICATION				TEST CONDITIONS
		MIN.	TYP.	MAX.	UNIT	
	I <sub>DD8</sub>		12		mA	V <sub>DD</sub> = 3 V@12 MHz, disable all IP and disable PLL, XTAL=12 MHz
Operating Current Normal Run Mode @ 4 MHz	I <sub>DD9</sub>		15		mA	V <sub>DD</sub> = 5 V@4 MHz, enable all IP and disable PLL, XTAL=4 MHz
	I <sub>DD10</sub>		11		mA	V <sub>DD</sub> = 5 V@4 MHz, disable all IP and disable PLL, XTAL=4 MHz
	I <sub>DD11</sub>		13		mA	V <sub>DD</sub> = 3 V@4 MHz, enable all IP and disable PLL, XTAL=4 MHz
	I <sub>DD12</sub>		9		mA	V <sub>DD</sub> = 3 V@4 MHz, disable all IP and disable PLL, XTAL=4 MHz
Operating Current Idle Mode @ 50 MHz	I <sub>IDLE1</sub>		38		mA	V <sub>DD</sub> = 5.5 V@50 MHz, enable all IP and PLL, XTAL=12 MHz
	I <sub>IDLE2</sub>		15		mA	V <sub>DD</sub> =5.5 V@50 MHz, disable all IP and enable PLL, XTAL=12 MHz
	I <sub>IDLE3</sub>		35		mA	V <sub>DD</sub> = 3 V@50 MHz, enable all IP and PLL, XTAL=12 MHz
	I <sub>IDLE4</sub>		13		mA	V <sub>DD</sub> = 3 V@50 MHz, disable all IP and enable PLL, XTAL=12 MHz
Operating Current Idle Mode @ 12 MHz	I <sub>IDLE5</sub>		13		mA	V <sub>DD</sub> = 5.5 V@12 MHz, enable all IP and disable PLL, XTAL=12 MHz
	I <sub>IDLE6</sub>		5.5		mA	V <sub>DD</sub> = 5.5 V@12 MHz, disable all IP and disable PLL, XTAL=12 MHz
	I <sub>IDLE7</sub>		12		mA	V <sub>DD</sub> = 3 V@12 MHz, enable all IP and disable PLL, XTAL=12 MHz



PARAMETER	SYM.	SPECIFICATION				TEST CONDITIONS
		MIN.	TYP.	MAX.	UNIT	
	I <sub>IDLE8</sub>		4		mA	V <sub>DD</sub> = 3 V@12 MHz, disable all IP and disable PLL, XTAL=12 MHz
Operating Current Idle Mode @ 4 MHz	I <sub>IDLE9</sub>		8.5		mA	V <sub>DD</sub> = 5 V@4 MHz, enable all IP and disable PLL, XTAL=4 MHz
	I <sub>IDLE10</sub>		3.5		mA	V <sub>DD</sub> = 5 V@4 MHz, disable all IP and disable PLL, XTAL=4 MHz
	I <sub>IDLE11</sub>		7		mA	V <sub>DD</sub> = 3 V@4 MHz, enable all IP and disable PLL, XTAL=4 MHz
	I <sub>IDLE12</sub>		2.5		mA	V <sub>DD</sub> = 3 V@4 MHz, disable all IP and disable PLL, XTAL=4 MHz
Standby Current Power down Mode	I <sub>PWD1</sub>		23		μA	V <sub>DD</sub> = 5.5 V, RTC OFF, No load @ Disable BOV function
	I <sub>PWD2</sub>		18		μA	V <sub>DD</sub> = 3.3 V, RTC OFF, No load @ Disable BOV function
	I <sub>PWD3</sub>		28		μA	V <sub>DD</sub> = 5.5 V, RTC run , No load @ Disable BOV function
	I <sub>PWD4</sub>		22		μA	V <sub>DD</sub> = 3.3 V, RTC run , No load @ Disable BOV function
Input Current PA, PB, PC, PD, PE (Quasi-bidirectional mode)	I <sub>IN1</sub>		-50	-60	μA	V <sub>DD</sub> = 5.5 V, V <sub>IN</sub> = 0 V or V <sub>IN</sub> =V <sub>DD</sub>
Input Current at /RESET <sup>[1]</sup>	I <sub>IN2</sub>	-55	-45	-30	μA	V <sub>DD</sub> = 3.3 V, V <sub>IN</sub> = 0.45 V
Input Leakage Current PA, PB, PC, PD, PE	I <sub>LK</sub>	-2	-	+2	μA	V <sub>DD</sub> = 5.5 V, 0<V <sub>IN</sub> <V <sub>DD</sub>
Logic 1 to 0 Transition Current PA~PE (Quasi-bidirectional mode)	I <sub>TL</sub> <sup>[3]</sup>	-650	-	-200	μA	V <sub>DD</sub> = 5.5 V, V <sub>IN</sub> <2.0 V
Input Low Voltage PA, PB, PC, PD, PE (TTL input)	V <sub>IL1</sub>	-0.3	-	0.8	V	V <sub>DD</sub> = 4.5 V
		-0.3	-	0.6		V <sub>DD</sub> = 2.5 V
Input High Voltage PA, PB, PC, PD, PE (TTL input)	V <sub>IH1</sub>	2.0	-	V <sub>DD</sub> +0.2	V	V <sub>DD</sub> = 5.5 V
		1.5	-	V <sub>DD</sub> +0.2		V <sub>DD</sub> =3.0 V
Input Low Voltage PA, PB, PC, PD, PE (Schmitt input)	V <sub>IL2</sub>	-0.5	-	0.2 V <sub>DD</sub>	V	



PARAMETER	SYM.	SPECIFICATION				TEST CONDITIONS
		MIN.	TYP.	MAX.	UNIT	
Input High Voltage PA, PB, PC, PD, PE (Schmitt input)	V <sub>IH2</sub>	0.4 V <sub>DD</sub>	-	V <sub>DD</sub> +0.5	V	
Hysteresis voltage of PA~PE (Schmitt input)	V <sub>HY</sub>		0.2 V <sub>DD</sub>		V	
Input Low Voltage XT1 <sup>[*2]</sup>	V <sub>IL3</sub>	0	-	0.8	V	V <sub>DD</sub> = 4.5 V
		0	-	0.4		V <sub>DD</sub> = 3.0 V
Input High Voltage XT1 <sup>[*2]</sup>	V <sub>IH3</sub>	3.5	-	V <sub>DD</sub> +0.2	V	V <sub>DD</sub> = 5.5 V
		2.4	-	V <sub>DD</sub> +0.2		V <sub>DD</sub> = 3.0 V
Input Low Voltage X32I <sup>[*2]</sup>	V <sub>IL4</sub>	0	-	0.4	V	
Input High Voltage X32I <sup>[*2]</sup>	V <sub>IH4</sub>	1.7		2.5	V	
Negative going threshold (Schmitt input), /RESET	V <sub>ILS</sub>	-0.5	-	0.3 V <sub>DD</sub>	V	
Positive going threshold (Schmitt input), /RESET	V <sub>IHS</sub>	0.7 V <sub>DD</sub>	-	V <sub>DD</sub> +0.5	V	
Source Current PA, PB, PC, PD, PE (Quasi-bidirectional Mode)	I <sub>SR11</sub>	-300	-370	-450	μA	V <sub>DD</sub> = 4.5 V, V <sub>S</sub> = 2.4 V
	I <sub>SR12</sub>	-50	-70	-90	μA	V <sub>DD</sub> = 2.7 V, V <sub>S</sub> = 2.2 V
	I <sub>SR13</sub>	-40	-60	-80	μA	V <sub>DD</sub> = 2.5 V, V <sub>S</sub> = 2.0 V
Source Current PA, PB, PC, PD, PE (Push-pull Mode)	I <sub>SR21</sub>	-20	-24	-28	mA	V <sub>DD</sub> = 4.5 V, V <sub>S</sub> = 2.4 V
	I <sub>SR22</sub>	-4	-6	-8	mA	V <sub>DD</sub> = 2.7 V, V <sub>S</sub> = 2.2 V
	I <sub>SR23</sub>	-3	-5	-7	mA	V <sub>DD</sub> = 2.5 V, V <sub>S</sub> = 2.0 V
Sink Current PA, PB, PC, PD, PE (Quasi-bidirectional and Push-pull Mode)	I <sub>SK11</sub>	10	16	20	mA	V <sub>DD</sub> = 4.5 V, V <sub>S</sub> = 0.45 V
	I <sub>SK12</sub>	7	10	13	mA	V <sub>DD</sub> = 2.7 V, V <sub>S</sub> = 0.45 V
	I <sub>SK13</sub>	6	9	12	mA	V <sub>DD</sub> = 2.5 V, V <sub>S</sub> = 0.45 V
Brown-Out voltage with BOV_VL [1:0] =00b	V <sub>BO2.2</sub>	2.1	2.2	2.3	V	
Brown-Out voltage with BOV_VL [1:0] =01b	V <sub>BO2.7</sub>	2.6	2.7	2.8	V	
Brown-Out voltage with BOV_VL [1:0] =10b	V <sub>BO3.8</sub>	3.6	3.8	4.0	V	
Brown-Out voltage with BOV_VL [1:0] =11b	V <sub>BO4.5</sub>	4.3	4.5	4.7	V	
Hysteresis range of BOD voltage	V <sub>BH</sub>	30	-	150	mV	V <sub>DD</sub> = 2.5 V~5.5 V



Note:

1. /RESET pin is a Schmitt trigger input.
2. Crystal Input is a CMOS input.
3. Pins of PA, PB, PC, PD and PE can source a transition current when they are being externally driven from 1 to 0. In the condition of  $V_{DD}=5.5\text{ V}$ , the transition current reaches its maximum value when  $V_{IN}$  approximates to 2 V.





## 7.2.2 NuMicro™ NUC100/NUC120 Low Density DC Electrical Characteristics

( $V_{DD}-V_{SS}=3.3\text{ V}$ ,  $T_A = 25^\circ\text{C}$ ,  $F_{OSC} = 50\text{ MHz}$  unless otherwise specified.)

PARAMETER	SYM.	SPECIFICATION				TEST CONDITIONS
		MIN.	TYP.	MAX.	UNIT	
Operation voltage	$V_{DD}$	2.5		5.5	V	$V_{DD} = 2.5\text{ V} \sim 5.5\text{ V}$ up to 50 MHz
Power Ground	$V_{SS}$ $AV_{SS}$	-0.3			V	
LDO Output Voltage	$V_{LDO}$	-10%	2.5	+10%	V	$V_{DD} > 2.7\text{ V}$
Analog Operating Voltage	$AV_{DD}$	0		$V_{DD}$	V	
Analog Reference Voltage	Vref	0		$AV_{DD}$	V	
Operating Current Normal Run Mode @ 50 MHz	$I_{DD1}$		46		mA	$V_{DD} = 5.5\text{ V}@50\text{ MHz}$ , enable all IP and PLL, XTAL=12 MHz
	$I_{DD2}$		30		mA	$V_{DD} = 5.5\text{ V}@50\text{ MHz}$ , disable all IP and enable PLL, XTAL=12 MHz
	$I_{DD3}$		44		mA	$V_{DD} = 3\text{ V}@50\text{ MHz}$ , enable all IP and PLL, XTAL=12 MHz
	$I_{DD4}$		28		mA	$V_{DD} = 3\text{ V}@50\text{ MHz}$ , disable all IP and enable PLL, XTAL=12 MHz
Operating Current Normal Run Mode @ 12 MHz	$I_{DD5}$		19		mA	$V_{DD} = 5.5\text{ V}@12\text{ MHz}$ , enable all IP and disable PLL, XTAL=12 MHz
	$I_{DD6}$		13		mA	$V_{DD} = 5.5\text{ V}@12\text{ MHz}$ , disable all IP and disable PLL, XTAL=12 MHz
	$I_{DD7}$		17		mA	$V_{DD} = 3\text{ V}@12\text{ MHz}$ , enable all IP and disable PLL, XTAL=12 MHz



PARAMETER	SYM.	SPECIFICATION				TEST CONDITIONS
		MIN.	TYP.	MAX.	UNIT	
	I <sub>DD8</sub>		11.5		mA	V <sub>DD</sub> = 3 V@12 MHz, disable all IP and disable PLL, XTAL=12 MHz
Operating Current Normal Run Mode @ 4 MHz	I <sub>DD9</sub>		13.5		mA	V <sub>DD</sub> = 5 V@4 MHz, enable all IP and disable PLL, XTAL=4 MHz
	I <sub>DD10</sub>		10		mA	V <sub>DD</sub> = 5 V@4 MHz, disable all IP and disable PLL, XTAL=4 MHz
	I <sub>DD11</sub>		12		mA	V <sub>DD</sub> = 3 V@4 MHz, enable all IP and disable PLL, XTAL=4 MHz
	I <sub>DD12</sub>		8		mA	V <sub>DD</sub> = 3 V@4 MHz, disable all IP and disable PLL, XTAL=4 MHz
Operating Current Idle Mode @ 50 MHz	I <sub>IDLE1</sub>		30		mA	V <sub>DD</sub> = 5.5 V@50 MHz, enable all IP and PLL, XTAL=12 MHz
	I <sub>IDLE2</sub>		13		mA	V <sub>DD</sub> =5.5 V@50 MHz, disable all IP and enable PLL, XTAL=12 MHz
	I <sub>IDLE3</sub>		28		mA	V <sub>DD</sub> = 3 V@50 MHz, enable all IP and PLL, XTAL=12 MHz
	I <sub>IDLE4</sub>		12		mA	V <sub>DD</sub> = 3 V@50 MHz, disable all IP and enable PLL, XTAL=12 MHz
Operating Current Idle Mode @ 12 MHz	I <sub>IDLE5</sub>		11		mA	V <sub>DD</sub> = 5.5 V@12 MHz, enable all IP and disable PLL, XTAL=12 MHz
	I <sub>IDLE6</sub>		5		mA	V <sub>DD</sub> = 5.5 V@12 MHz, disable all IP and disable PLL, XTAL=12 MHz
	I <sub>IDLE7</sub>		10		mA	V <sub>DD</sub> = 3 V@12 MHz, enable all IP and disable PLL, XTAL=12 MHz



PARAMETER	SYM.	SPECIFICATION				TEST CONDITIONS
		MIN.	TYP.	MAX.	UNIT	
	I <sub>IDLE8</sub>		4		mA	V <sub>DD</sub> = 3 V@12 MHz, disable all IP and disable PLL, XTAL=12 MHz
Operating Current Idle Mode @ 4 MHz	I <sub>IDLE9</sub>		7		mA	V <sub>DD</sub> = 5 V@4 MHz, enable all IP and disable PLL, XTAL=4 MHz
	I <sub>IDLE10</sub>		3.5		mA	V <sub>DD</sub> = 5 V@4 MHz, disable all IP and disable PLL, XTAL=4 MHz
	I <sub>IDLE11</sub>		6		mA	V <sub>DD</sub> = 3 V@4 MHz, enable all IP and disable PLL, XTAL=4 MHz
	I <sub>IDLE12</sub>		2.5		mA	V <sub>DD</sub> = 3 V@4 MHz, disable all IP and disable PLL, XTAL=4 MHz
Standby Current Power down Mode	I <sub>PWD1</sub>		17		μA	V <sub>DD</sub> = 5.5 V, RTC OFF, No load @ Disable BOV function
	I <sub>PWD2</sub>		14.5		μA	V <sub>DD</sub> = 3.3 V, RTC OFF, No load @ Disable BOV function
	I <sub>PWD3</sub>		20		μA	V <sub>DD</sub> = 5.5 V, RTC run , No load @ Disable BOV function
	I <sub>PWD4</sub>		17		μA	V <sub>DD</sub> = 3.3 V, RTC run , No load @ Disable BOV function
Input Current PA, PB, PC, PD, PE (Quasi-bidirectional mode)	I <sub>IN1</sub>		-50	-60	μA	V <sub>DD</sub> = 5.5 V, V <sub>IN</sub> = 0 V or V <sub>IN</sub> =V <sub>DD</sub>
Input Current at /RESET <sup>[1]</sup>	I <sub>IN2</sub>	-55	-45	-30	μA	V <sub>DD</sub> = 3.3 V, V <sub>IN</sub> = 0.45 V
Input Leakage Current PA, PB, PC, PD, PE	I <sub>LK</sub>	-2	-	+2	μA	V <sub>DD</sub> = 5.5 V, 0<V <sub>IN</sub> <V <sub>DD</sub>
Logic 1 to 0 Transition Current PA~PE (Quasi-bidirectional mode)	I <sub>TL</sub> <sup>[3]</sup>	-650	-	-200	μA	V <sub>DD</sub> = 5.5 V, V <sub>IN</sub> <2.0 V
Input Low Voltage PA, PB, PC, PD, PE (TTL input)	V <sub>IL1</sub>	-0.3	-	0.8	V	V <sub>DD</sub> = 4.5 V
		-0.3	-	0.6		V <sub>DD</sub> = 2.5 V
Input High Voltage PA, PB, PC, PD, PE (TTL input)	V <sub>IH1</sub>	2.0	-	V <sub>DD</sub> +0.2	V	V <sub>DD</sub> = 5.5 V
		1.5	-	V <sub>DD</sub> +0.2		V <sub>DD</sub> =3.0 V
Input Low Voltage PA, PB, PC, PD, PE (Schmitt input)	V <sub>IL2</sub>	-0.5	-	0.2 V <sub>DD</sub>	V	



PARAMETER	SYM.	SPECIFICATION				TEST CONDITIONS
		MIN.	TYP.	MAX.	UNIT	
Input High Voltage PA, PB, PC, PD, PE (Schmitt input)	V <sub>IH2</sub>	0.4 V <sub>DD</sub>	-	V <sub>DD</sub> +0.5	V	
Hysteresis voltage of PA~PE (Schmitt input)	V <sub>HY</sub>		0.2 V <sub>DD</sub>		V	
Input Low Voltage XT1 <sup>[*2]</sup>	V <sub>IL3</sub>	0	-	0.8	V	V <sub>DD</sub> = 4.5 V
		0	-	0.4		V <sub>DD</sub> = 3.0 V
Input High Voltage XT1 <sup>[*2]</sup>	V <sub>IH3</sub>	3.5	-	V <sub>DD</sub> +0.2	V	V <sub>DD</sub> = 5.5 V
		2.4	-	V <sub>DD</sub> +0.2		V <sub>DD</sub> = 3.0 V
Input Low Voltage X32I <sup>[*2]</sup>	V <sub>IL4</sub>	0	-	0.4	v	
Input High Voltage X32I <sup>[*2]</sup>	V <sub>IH4</sub>	1.7		2.5	V	
Negative going threshold (Schmitt input), /RESET	V <sub>ILS</sub>	-0.5	-	0.3 V <sub>DD</sub>	V	
Positive going threshold (Schmitt input), /RESET	V <sub>IHS</sub>	0.7 V <sub>DD</sub>	-	V <sub>DD</sub> +0.5	V	
Source Current PA, PB, PC, PD, PE (Quasi-bidirectional Mode)	I <sub>SR11</sub>	-300	-370	-450	μA	V <sub>DD</sub> = 4.5 V, V <sub>S</sub> = 2.4 V
	I <sub>SR12</sub>	-50	-70	-90	μA	V <sub>DD</sub> = 2.7 V, V <sub>S</sub> = 2.2 V
	I <sub>SR12</sub>	-40	-60	-80	μA	V <sub>DD</sub> = 2.5 V, V <sub>S</sub> = 2.0 V
Source Current PA, PB, PC, PD, PE (Push-pull Mode)	I <sub>SR21</sub>	-20	-24	-28	mA	V <sub>DD</sub> = 4.5 V, V <sub>S</sub> = 2.4 V
	I <sub>SR22</sub>	-4	-6	-8	mA	V <sub>DD</sub> = 2.7 V, V <sub>S</sub> = 2.2 V
	I <sub>SR22</sub>	-3	-5	-7	mA	V <sub>DD</sub> = 2.5 V, V <sub>S</sub> = 2.0 V
Sink Current PA, PB, PC, PD, PE (Quasi-bidirectional and Push-pull Mode)	I <sub>SK1</sub>	10	16	20	mA	V <sub>DD</sub> = 4.5 V, V <sub>S</sub> = 0.45 V
	I <sub>SK1</sub>	7	10	13	mA	V <sub>DD</sub> = 2.7 V, V <sub>S</sub> = 0.45 V
	I <sub>SK1</sub>	6	9	12	mA	V <sub>DD</sub> = 2.5 V, V <sub>S</sub> = 0.45 V
Brown-Out voltage with BOV_VL [1:0] =00b	V <sub>BO2.2</sub>	2.1	2.2	2.3	V	
Brown-Out voltage with BOV_VL [1:0] =01b	V <sub>BO2.7</sub>	2.6	2.7	2.8	V	
Brown-Out voltage with BOV_VL [1:0] =10b	V <sub>BO3.8</sub>	3.6	3.8	4.0	V	
Brown-Out voltage with BOV_VL [1:0] =11b	V <sub>BO4.5</sub>	4.3	4.5	4.7	V	
Hysteresis range of BOD voltage	V <sub>BH</sub>	30	-	150	mV	V <sub>DD</sub> = 2.5 V~5.5 V



PARAMETER	SYM.	SPECIFICATION				TEST CONDITIONS
		MIN.	TYP.	MAX.	UNIT	
Bandgap voltage	V <sub>BG</sub>	1.20	1.26	1.32	V	V <sub>DD</sub> = 2.5 V~5.5 V

Note:

1. /RESET pin is a Schmitt trigger input.
2. Crystal Input is a CMOS input.
3. Pins of PA, PB, PC, PD and PE can source a transition current when they are being externally driven from 1 to 0. In the condition of V<sub>DD</sub>=5.5 V, the transition current reaches its maximum value when V<sub>IN</sub> approximates to 2 V.



**7.2.3 Operating Current Curve (Test condition: run NOP)**

1. XTAL clock = 12 MHz, PLL disable, all-IP disable:

Unit: mA

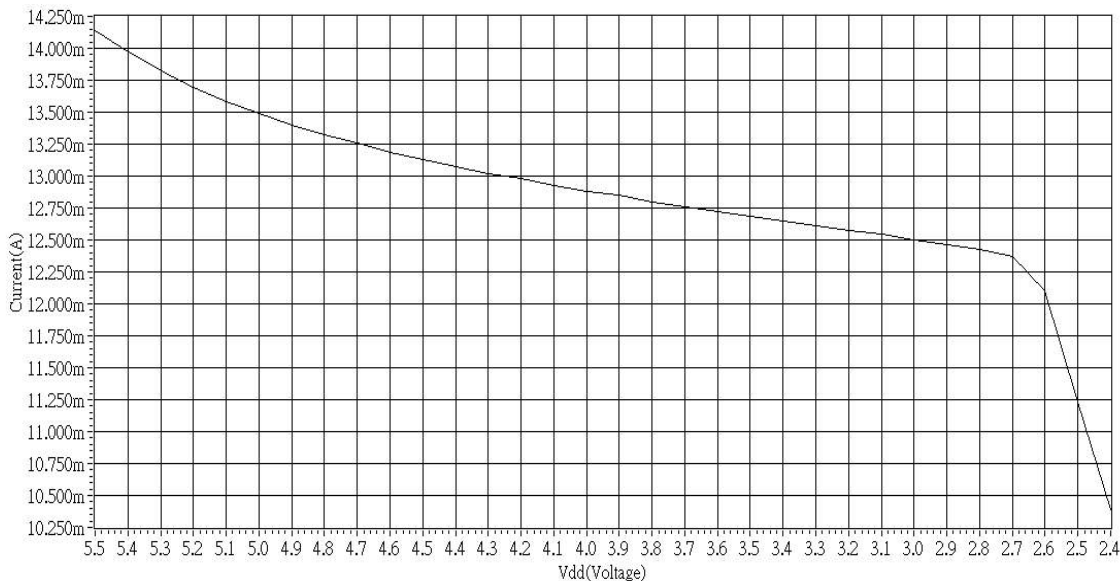

2. XTAL clock = 12 MHz, PLL disable, all-IP enable

Unit: mA

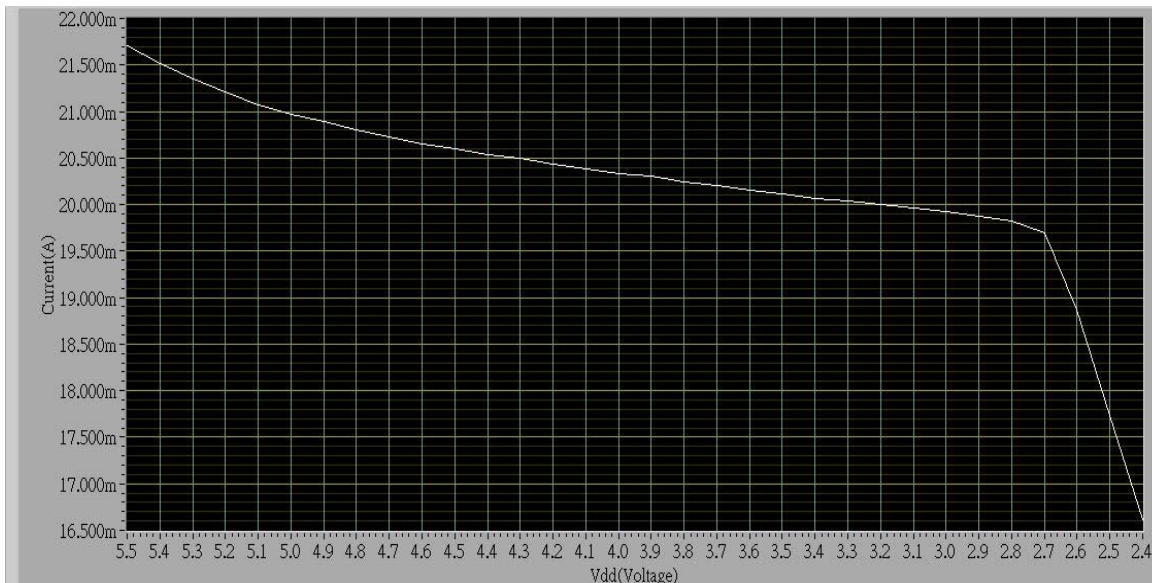



3. XTAL clock = 12 MHz, PLL enable, all-IP disable

Unit: mA

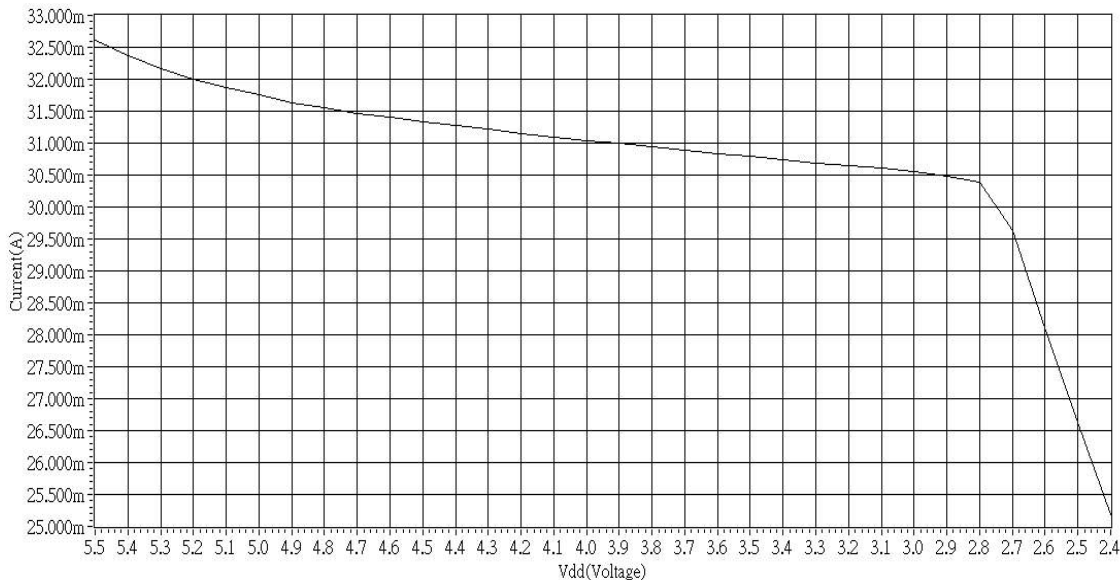

4. XTAL clock = 12 MHz, PLL enable, all-IP enable

Unit: mA

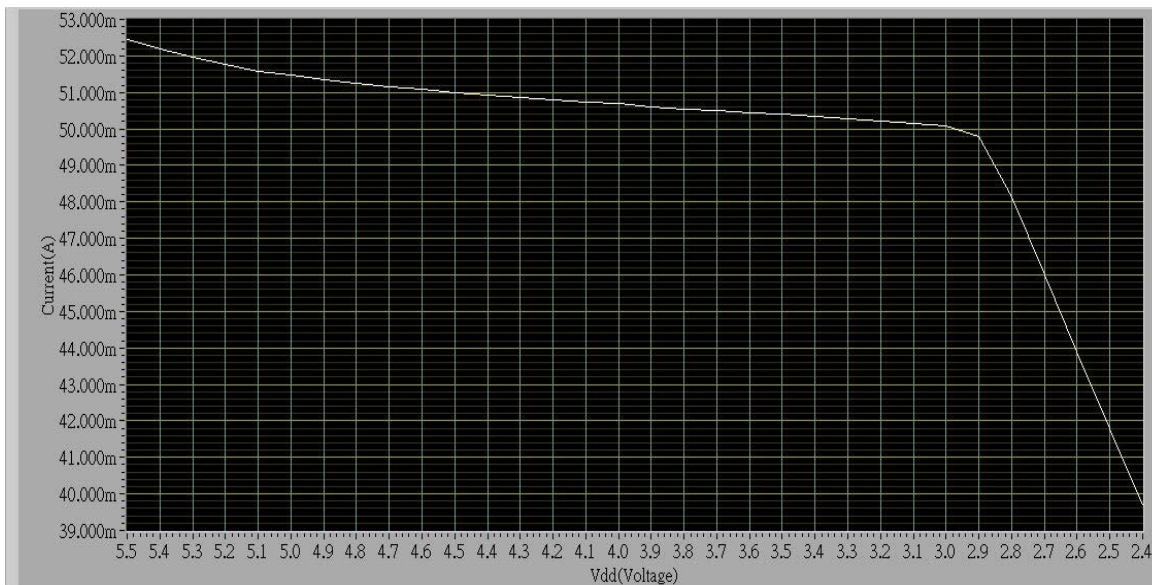



**7.2.4 Idle Current Curve**

1. XTAL clock = 12 MHz, PLL disable, all-IP disable

Unit: mA

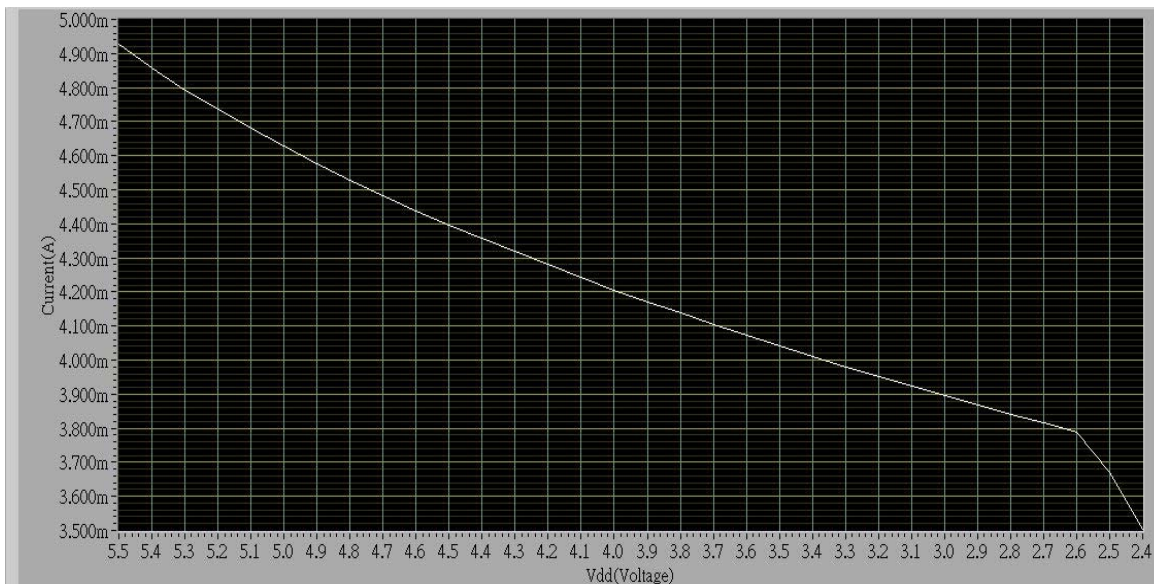

2. XTAL clock = 12 MHz, PLL disable, all-IP enable

Unit: mA

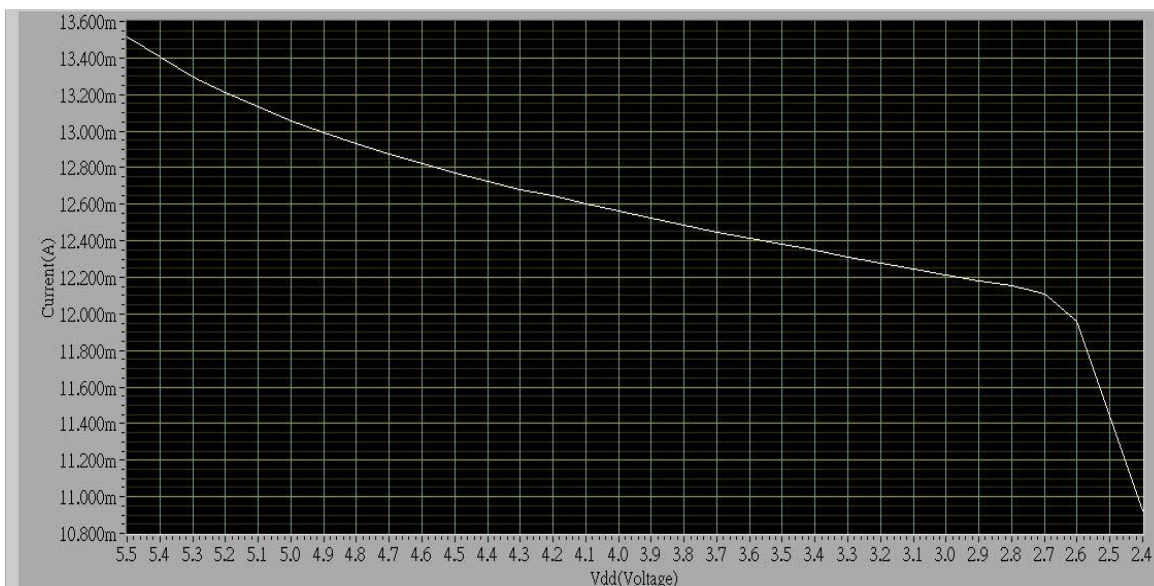





3. XTAL clock = 12 MHz, PLL enable, all-IP disable

Unit: mA

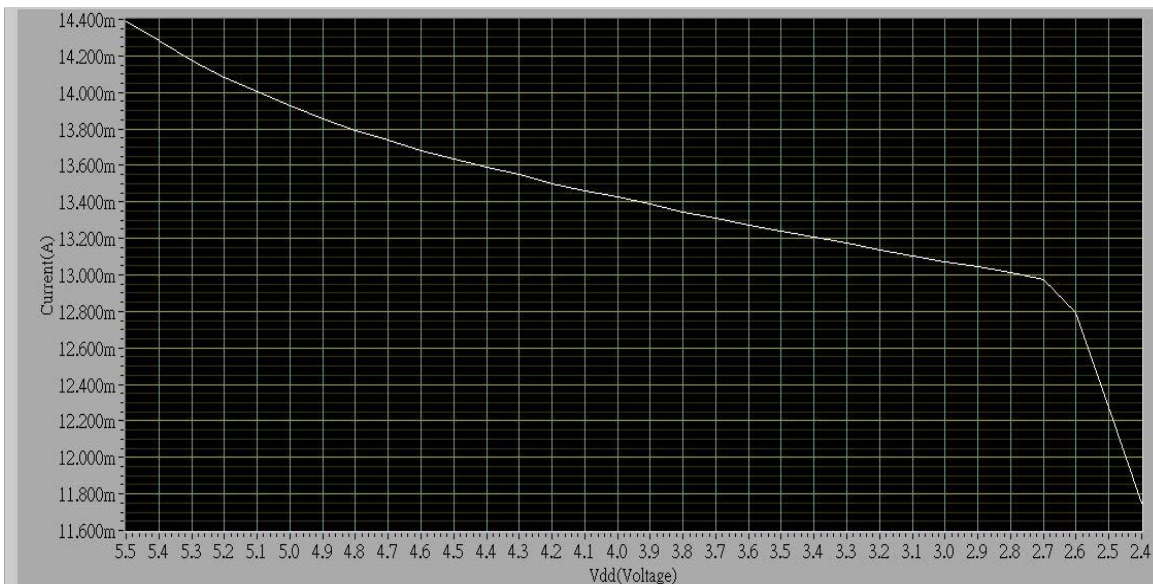

4. XTAL clock = 12 MHz, PLL enable, all-IP enable

Unit: mA

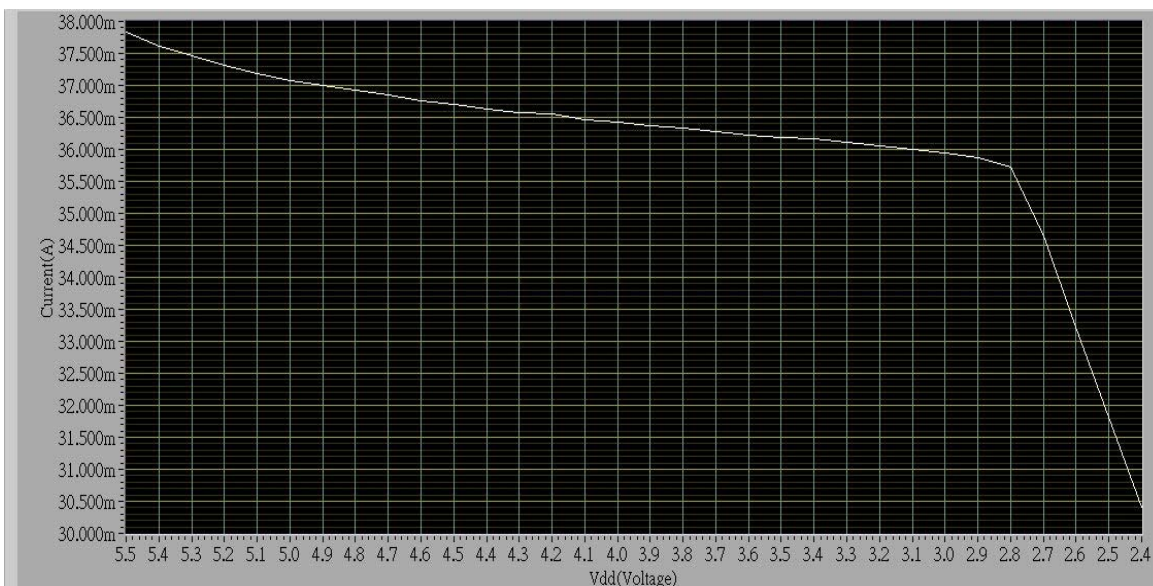



## 7.2.5 Power Down Current Curve

XTAL clock = 12 MHz, PLL Disable

Unit: mA

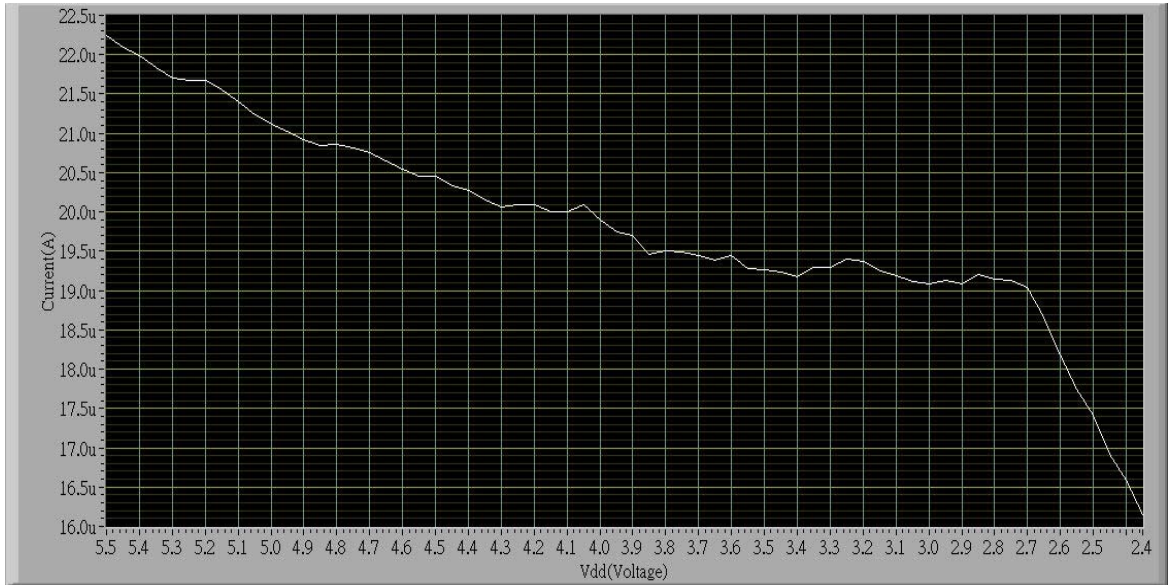



7.3 AC Electrical Characteristics

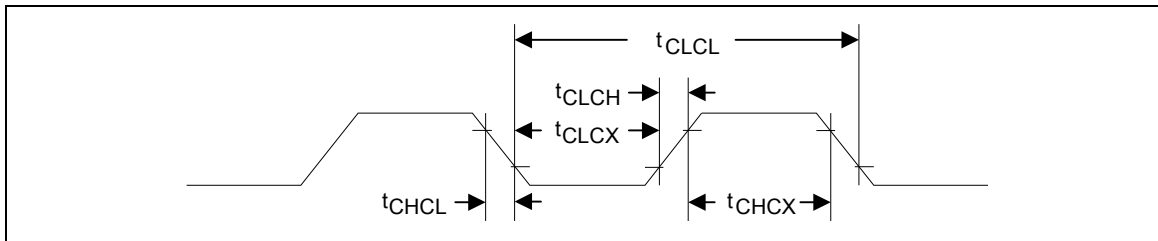

Note: Duty cycle is 50%.

SYMBOL	PARAMETER	CONDITION	MIN.	TYP.	MAX.	UNIT
t <sub>CHCX</sub>	Clock High Time		20	-	-	nS
t <sub>CLCX</sub>	Clock Low Time		20	-	-	nS
t <sub>CLCH</sub>	Clock Rise Time		-	-	10	nS
t <sub>CHCL</sub>	Clock Fall Time		-	-	10	nS

7.3.1 External 4~24 MHz High Speed Crystal

PARAMETER	CONDITION	MIN.	TYP.	MAX.	UNIT
Input clock frequency	External crystal	4	12	24	MHz
Temperature	-	-40	-	85	°C
V <sub>DD</sub>	-	2.5	5	5.5	V
Operating current	12 MHz@ V <sub>DD</sub> = 5V	-	1	-	mA

7.3.1.1 Typical Crystal Application Circuits

CRYSTAL	C1	C2	R
4 MHz ~ 24 MHz	without	without	without

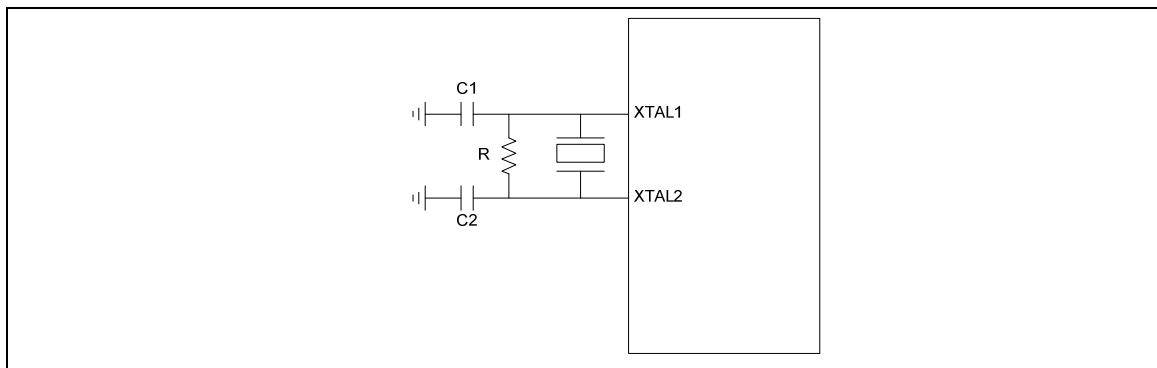

Figure 7-1 Typical Crystal Application Circuit

### 7.3.2 External 32.768 kHz Low Speed Crystal

PARAMETER	CONDITION	MIN.	TYP.	MAX.	UNIT
Input clock frequency	External crystal	-	32.768	-	kHz
Temperature	-	-40	-	85	°C
V <sub>DD</sub>	-	2.5	-	5.5	V

### 7.3.3 Internal 22.1184 MHz High Speed Oscillator

PARAMETER	CONDITION	MIN.	TYP.	MAX.	UNIT
Supply voltage <sup>[1]</sup>	-	2.5	-	5.5	V
Center Frequency	-	-	22.1184	-	MHz
Calibrated Internal Oscillator Frequency	+25°C; V <sub>DD</sub> = 5 V	-1	-	+1	%
	-40°C~+85°C; V <sub>DD</sub> =2.5 V~5.5 V	-3	-	+3	%
Operation Current	V <sub>DD</sub> = 5 V	-	500	-	uA

### 7.3.4 Internal 10 kHz Low Speed Oscillator

PARAMETER	CONDITION	MIN.	TYP.	MAX.	UNIT
Supply voltage <sup>[1]</sup>	-	2.5	-	5.5	V
Center Frequency	-	-	10	-	kHz
Calibrated Internal Oscillator Frequency	+25°C; V <sub>DD</sub> = 5 V	-30	-	+30	%
	-40°C~+85°C; V <sub>DD</sub> =2.5 V~5.5 V	-50	-	+50	%

Note: Internal operation voltage comes from LDO.





## 7.4 Analog Characteristics

### 7.4.1 Specification of 12-bit SARADC

SYMBOL	PARAMETER	MIN.	TYP.	MAX.	UNIT
-	Resolution	-	-	12	Bit
DNL	Differential nonlinearity error	-	±3	-	LSB
INL	Integral nonlinearity error	-	±4	-	LSB
EO	Offset error	-	±1	10	LSB
EG	Gain error (Transfer gain)	-	1	1.005	-
-	Monotonic	Guaranteed			
FADC	ADC clock frequency ( $AV_{DD}=5V/3V$ )	-	-	16/8	MHz
FS	Sample rate	-	-	600	K SPS
$V_{DDA}$	Supply voltage	3	-	5.5	V
$I_{DD}$	Supply current (Avg.)	-	0.5	-	mA
$I_{DDA}$		-	1.5	-	mA
$V_{REF}$	Reference voltage	-	$V_{DDA}$	-	V
$I_{REF}$	Reference current (Avg.)	-	1	-	mA
$V_{IN}$	Input voltage	0	-	$V_{REF}$	V

#### 7.4.2 Specification of LDO and Power management

PARAMETER	MIN.	TYP.	MAX.	UNIT	NOTE
Input Voltage	2.7	5	5.5	V	V <sub>DD</sub> input voltage
Output Voltage	-10%	2.5	+10%	V	V <sub>DD</sub> > 2.7 V
Temperature	-40	25	85	°C	
Cbp	-	1	-	uF	Resr=1ohm

Note:

1. It is recommended that a 10uF or higher capacitor and a 100nF bypass capacitor are connected between V<sub>DD</sub> and the closest V<sub>SS</sub> pin of the device.
2. For ensuring power stability, a 1uF or higher capacitor must be connected between LDO pin and the closest V<sub>SS</sub> pin of the device.



**7.4.3 Specification of Low Voltage Reset**

PARAMETER	CONDITION	MIN.	TYP.	MAX.	UNIT
Operation voltage	-	1.7	-	5.5	V
Quiescent current	V <sub>DD</sub> =5.5 V	-	-	5	uA
Temperature	-	-40	25	85	°C
Threshold voltage	Temperature=25°C	1.7	2.0	2.3	V
	Temperature=-40°C	-	2.4	-	V
	Temperature=85°C	-	1.6	-	V
Hysteresis	-	0	0	0	V

**7.4.4 Specification of Brown-Out Detector**

PARAMETER	CONDITION	MIN.	TYP.	MAX.	UNIT
Operation voltage	-	2.5	-	5.5	V
Quiescent current	AV <sub>DD</sub> =5.5 V	-	-	125	µA
Temperature	-	-40	25	85	°C
Brown-Out voltage	BOV_VL[1:0]=11	4.3	4.5	4.7	V
	BOV_VL [1:0]=10	3.6	3.8	4.0	V
	BOV_VL [1:0]=01	2.6	2.7	2.8	V
	BOV_VL [1:0]=00	2.1	2.2	2.3	V
Hysteresis	-	30	-	150	mV

**7.4.5 Specification of Power-On Reset (5 V)**

PARAMETER	CONDITION	MIN.	TYP.	MAX.	UNIT
Temperature	-	-40	25	85	°C
Reset voltage	V+	-	2	-	V
Quiescent current	V <sub>in</sub> >reset voltage	-	1	-	nA





7.4.6 Specification of Temperature Sensor

PARAMETER	CONDITIONS	MIN.	TYP.	MAX.	UNIT
Supply voltage <sup>[1]</sup>		2.5	-	5.5	V
Temperature		-40	-	125	°C
Current consumption		6.4	-	10.5	uA
Gain			-1.76		mV/°C
Offset	Temp=0 °C		720		mV

Note: Internal operation voltage comes from LDO.

7.4.7 Specification of Comparator

PARAMETER	CONDITION	MIN.	TYP.	MAX.	UNIT
Temperature	-	-40	25	85	°C
V <sub>DD</sub>	-	2.4	3	5.5	V
V <sub>DD</sub> current	20 uA@V <sub>DD</sub> =3 V	-	20	40	uA
Input offset voltage	-	-	5	15	mV
Output swing	-	0.1	-	V <sub>DD</sub> -0.1	V
Input common mode range	-	0.1	-	V <sub>DD</sub> -1.2	V
DC gain	-	-	70	-	dB
Propagation delay	@V <sub>CM</sub> =1.2 V and V <sub>DIFF</sub> =0.1 V	-	200	-	ns
Comparison voltage	20 mV@V <sub>CM</sub> =1 V 50 mV@V <sub>CM</sub> =0.1 V 50 mV@V <sub>CM</sub> =V <sub>DD</sub> -1.2 @10 mV for non-hysteresis	10	20	-	mV
Hysteresis	One bit control W/O and W. hysteresis @V <sub>CM</sub> =0.4 V ~ V <sub>DD</sub> -1.2 V	-	±10	-	mV
Wake-up time	@C <sub>INP</sub> =1.3 V C <sub>INN</sub> =1.2 V	-	-	2	us



**7.4.8 Specification of USB PHY**

**7.4.8.1 USB DC Electrical Characteristics**

SYMBOL	PARAMETER	CONDITIONS	MIN.	TYP.	MAX.	UNIT
V <sub>IH</sub>	Input high (driven)		2.0			V
V <sub>IL</sub>	Input low				0.8	V
V <sub>DI</sub>	Differential input sensitivity	PADP-PADM	0.2			V
V <sub>CM</sub>	Differential common-mode range	Includes V <sub>DI</sub> range	0.8		2.5	V
V <sub>SE</sub>	Single-ended receiver threshold		0.8		2.0	V
	Receiver hysteresis			200		mV
V <sub>OL</sub>	Output low (driven)		0		0.3	V
V <sub>OH</sub>	Output high (driven)		2.8		3.6	V
V <sub>CRS</sub>	Output signal cross voltage		1.3		2.0	V
R <sub>PU</sub>	Pull-up resistor		1.425		1.575	kΩ
V <sub>TRM</sub>	Termination Voltage for upstream port pull up (RPU)		3.0		3.6	V
Z <sub>DRV</sub>	Driver output resistance	Steady state drive*		10		Ω
C <sub>IN</sub>	Transceiver capacitance	Pin to GND			20	pF

\*Driver output resistance doesn't include series resistor resistance.

**7.4.8.2 USB Full-Speed Driver Electrical Characteristics**

SYMBOL	PARAMETER	CONDITIONS	MIN.	TYP.	MAX.	UNIT
T <sub>FR</sub>	Rise Time	C <sub>L</sub> =50p	4		20	ns
T <sub>FF</sub>	Fall Time	C <sub>L</sub> =50p	4		20	ns
T <sub>FRFF</sub>	Rise and fall time matching	T <sub>FRFF</sub> =T <sub>FR</sub> /T <sub>FF</sub>	90		111.11	%

**7.4.8.3 USB Power Dissipation**

SYMBOL	PARAMETER	CONDITIONS	MIN.	TYP.	MAX.	UNIT
I <sub>VDDREG</sub> (Full Speed)	V <sub>DDD</sub> and V <sub>DDREG</sub> Supply Current (Steady State)	Standby		50		uA
		Input mode				uA
		Output mode				uA



## 7.5 Flash DC Electrical Characteristics

SYMBOL	PARAMETER	CONDITIONS	MIN.	TYP.	MAX.	UNIT
N <sub>endu</sub>	Endurance		10000			cycles <sup>[1]</sup>
T <sub>ret</sub>	Retention time	Temp=25 °C	100			year
T <sub>erase</sub>	Page erase time		20		40	ms
T <sub>mass</sub>	Mass erase time		40	50	60	ms
T <sub>prog</sub>	Program time		35	40	55	us
V <sub>dd</sub>	Supply voltage		2.25	2.5	2.75	V <sup>[2]</sup>
I <sub>dd1</sub>	Read current				14	mA
I <sub>dd2</sub>	Program/Erase current				7	mA
I <sub>pd</sub>	Power down current				10	uA

1. Number of program/erase cycles.
2. V<sub>dd</sub> is source from chip LDO output voltage.
3. This table is guaranteed by design, not test in production.

## 7.6 SPI Dynamic Characteristics

SYMBOL	PARAMETER	MIN.	TYP.	MAX.	UNIT
SPI master mode ( $V_{DD} = 4.5V \sim 5.5V$ , 30pF loading Capacitor)					
$t_{DS}$	Data setup time	26	18	-	ns
$t_{DH}$	Data hold time	0	-	-	ns
$t_V$	Data output valid time	-	4	6	ns
SPI master mode ( $V_{DD} = 3.0V \sim 3.6V$ , 30pF loading Capacitor)					
$t_{DS}$	Data setup time	39	26	-	ns
$t_{DH}$	Data hold time	0	-	-	ns
$t_V$	Data output valid time	-	6	10	ns
SPI slave mode ( $V_{DD} = 4.5V \sim 5.5V$ , 30pF loading Capacitor)					
$t_{DS}$	Data setup time	0	-	-	ns
$t_{DH}$	Data hold time	$2 \cdot PCLK + 4$	-	-	ns
$t_V$	Data output valid time	-	$2 \cdot PCLK + 19$	$2 \cdot PCLK + 27$	ns
SPI slave mode ( $V_{DD} = 3.0V \sim 3.6V$ , 30pF loading Capacitor)					
$t_{DS}$	Data setup time	0	-	-	ns
$t_{DH}$	Data hold time	$2 \cdot PCLK + 8$	-	-	ns
$t_V$	Data output valid time	-	$2 \cdot PCLK + 27$	$2 \cdot PCLK + 40$	ns

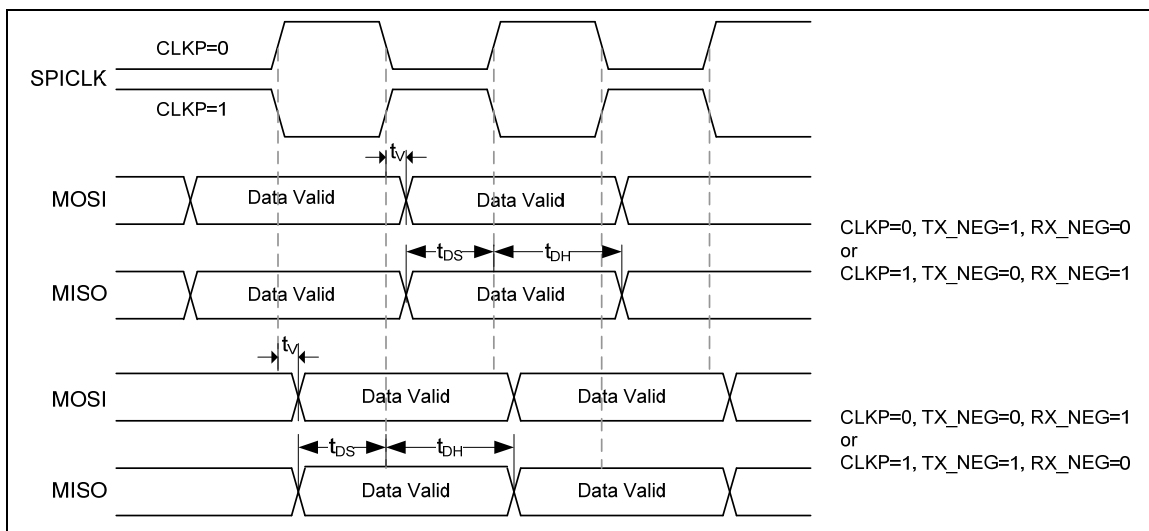

Figure 7-2 SPI Master dynamic characteristics timing

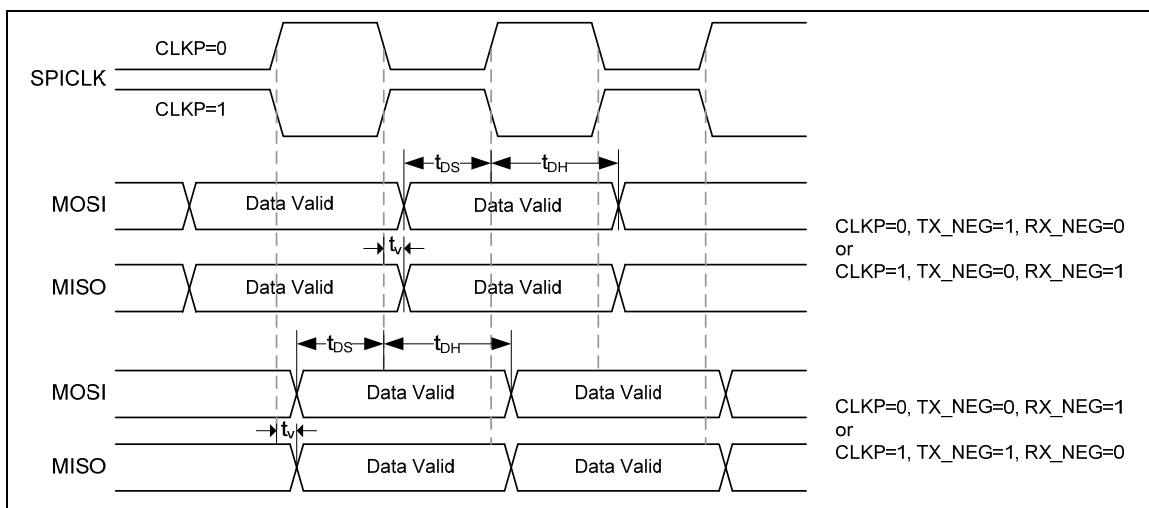
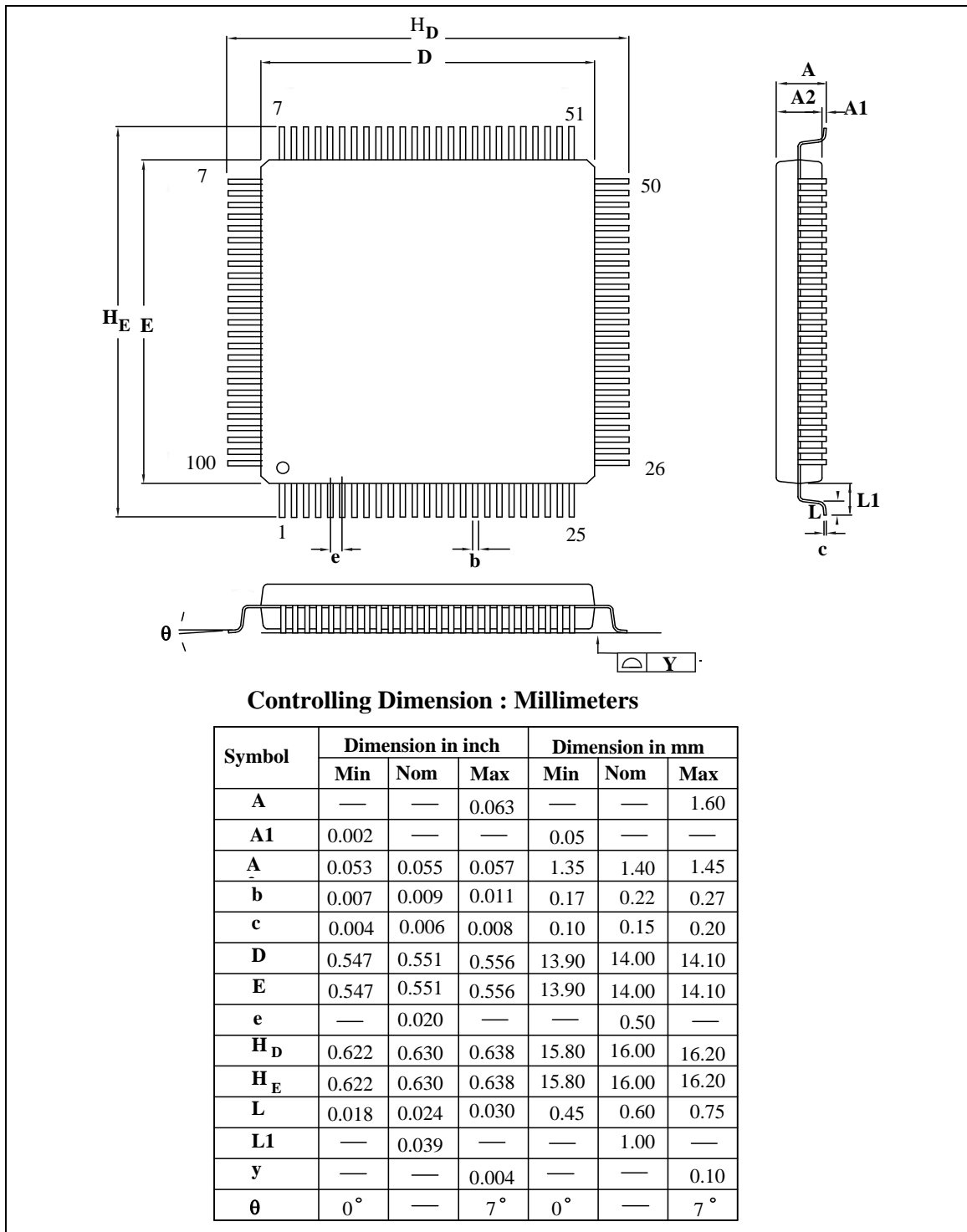

Figure 7-3 SPI Slave dynamic characteristics timing

8 PACKAGE DIMENSIONS

8.1 100L LQFP (14x14x1.4 mm footprint 2.0mm)



8.2 64L LQFP (10x10x1.4mm footprint 2.0 mm)

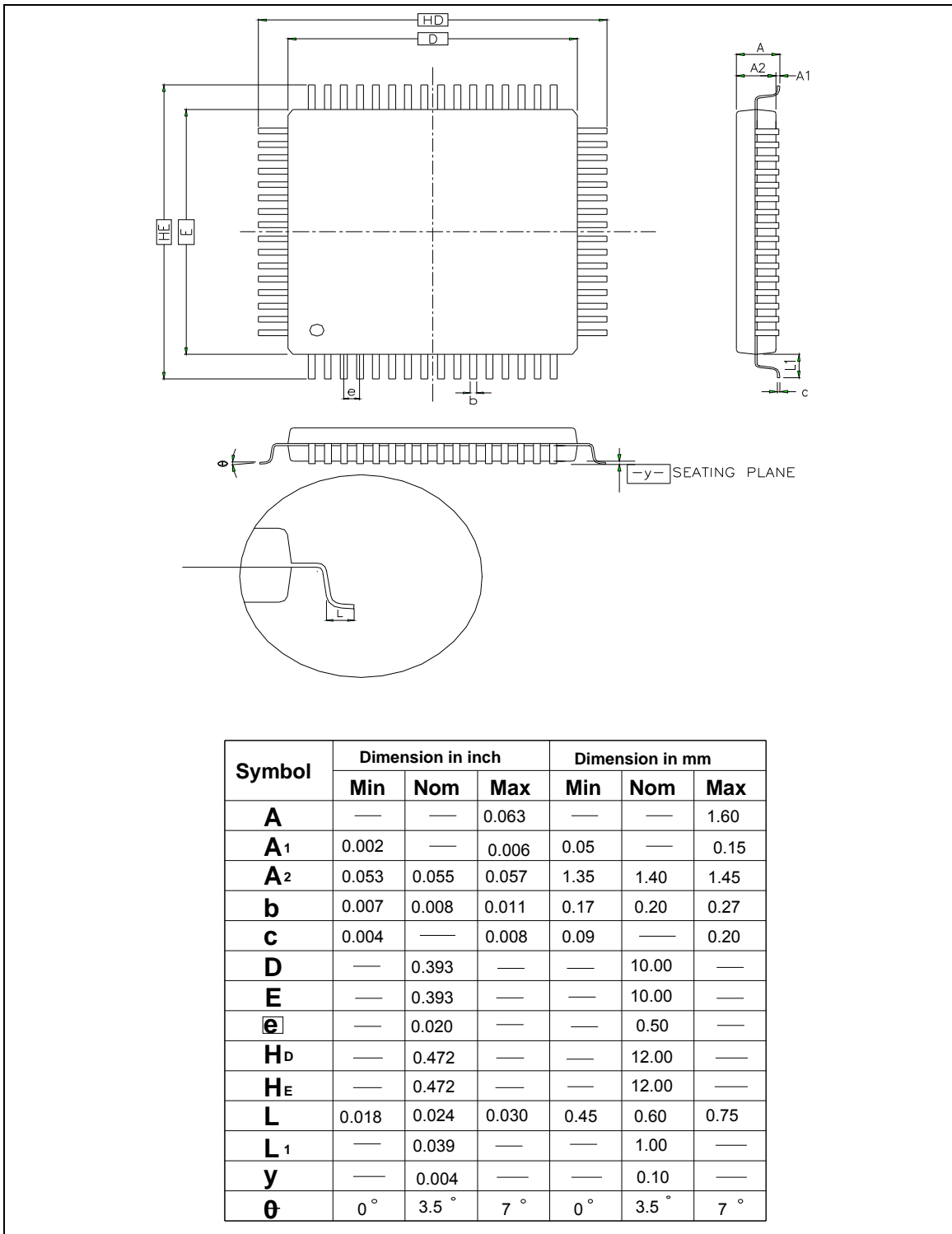



8.3 48L LQFP (7x7x1.4mm footprint 2.0mm)

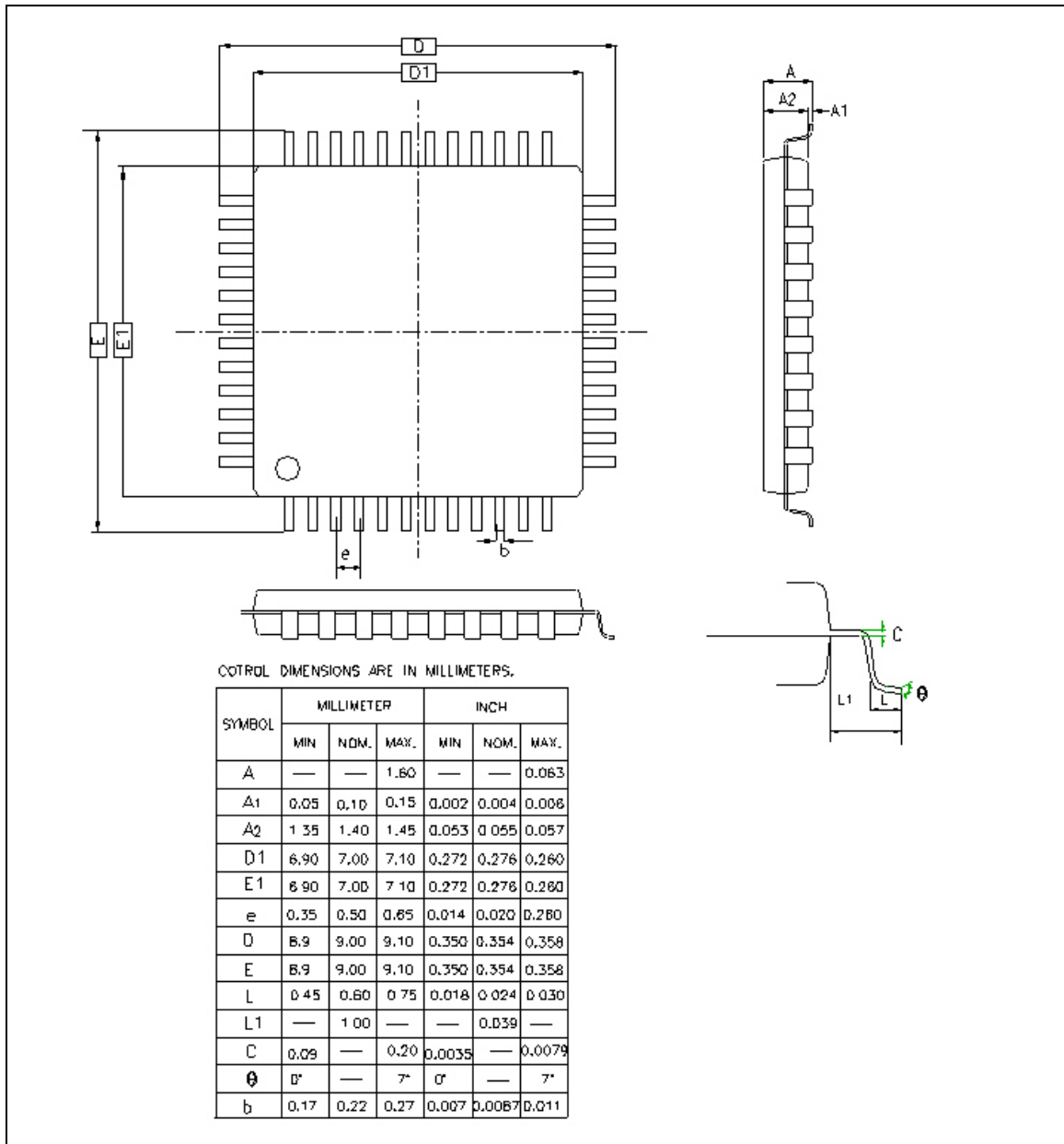





9 REVISION HISTORY

VERSION	DATE	PAGE/ CHAPTER	DESCRIPTION
V1.00	Mar. 27, 2010	-	Preliminary version initial issued
V1.01	April 23, 2010	Page 529 -	<ol style="list-style-type: none"> <li>1. Correct the error in CBOV[1:0] of Config0</li> <li>2. Add NUC101 QFN 36-pin parts</li> <li>3. Add current curve in DC characteristics.</li> </ol>
V1.02	May 5, 2010		<ol style="list-style-type: none"> <li>1. Revise NUC101 selection guide.</li> </ol>
V1.03	June 7, 2010	Chapter 5.6 Chapter 5.8	<ol style="list-style-type: none"> <li>1. Update the section content of I<sup>2</sup>C Serial Interface Controller.</li> <li>2. Update the section content of Real Time Clock (RTC).</li> </ol>
V1.04	Aug. 23, 2010	Page 34 Page 492	<ol style="list-style-type: none"> <li>1. Modify Pin Description</li> <li>2. Modify operation current of DC characteristics</li> </ol>
V1.05	Sep. 14, 2010	Page 343 Page 329 Page 457	<ol style="list-style-type: none"> <li>1. Add RS485 for low density</li> <li>2. Correct the WDT bit length</li> <li>3. Add EBI interface for low density</li> </ol>
V1.06	Oct. 26, 2010	Chapter 5.10 Chapter 5.7.6	<ol style="list-style-type: none"> <li>1. Modify TIMER feature description and add function description</li> <li>2. Modify CCR0 and PIER bit description</li> </ol>
V2.00	May. 04, 2011	All Chapter 5.17.6 Chapter 5.16.5 All All Page 172 Page 169 Chapter 5.6.5 Chapter 5.3 Chapter 5.7.6 Chapter 5.12 Chapter 5.13.6 Chapter 6.10	<ol style="list-style-type: none"> <li>1. Remove NUC130/NUC140/NUC101 description</li> <li>2. Revise note description of register PDMA_ISR</li> <li>3. Revise default value of register CMPSR</li> <li>4. Remove word "MICROWIRE" in all document</li> <li>5. Remove "float detect pin" word in description</li> <li>6. Revise diagram: "Wake-up Interrupt Operation Flow" and "Data Out Transfer"</li> <li>7. Revise default value of register I2CSTATUS</li> <li>8. Remove reserved clock source description and diagram for Timer and Watchdog and revise timer block description from "five options" to "four options"</li> <li>9. Revise "Capture channel 0 is from pin PB.11" in register CAPENR</li> <li>10. Remove LIN description</li> <li>11. Revise "PS2DAT" to "PS2CLK" in register FPS2CLK</li> <li>12. Add register field LFOM in FATCON</li> </ol>



		Figure 5-86 Figure 5-4	13. Revise diagram “ADC Controller Block Diagram” and “Clock generator global view diagram”
		Chapter 5.10.4	14. Add description of Timer continuous counting mode and event counting function
		Chapter 5.2.3	15. Add description to set the same voltage level between AVDD and VDD
		Chapter 5.11	16. Revise description of WDT time out period and interrupt period
		Chapter 5.10.6	17. Revise description of register TCMP
		Chapter 3.3.1	18. Remove TM0~3 of medium density
		Chapter 7.6	19. Add SPI Dynamic Characteristics
V2.01	June 14, 2011	Chapter 6.10 Chapter 7.4.6 Chapter 3.4	1. Revise ISPCON.BS description 2. Modify temperature sensor spec 3. Revise Pin description position for multi-function T2EX, T3EX, nRD, nWR
		Chapter 7.6 Chapter 7.4.4	4. Update title of SPI Dynamic Characteristics 5. Update BOD spec
V2.02	Jan. 2, 2012	Page 331 Page 360 Chapter 5.2.7 Page 281 Page 278 Chapter 5.8.4 Page 293 Page 282 Chapter 5.8.4.3 Chapter 7.4.1 Chapter 5.7.4.6 Chapter 5.7.4.10 Page 351 Chapter 3.1.1	1. Update WDT block diagram for typo 2. Release PDMA/debug register in UA_ISR register 3. Remove feature “Dynamic priority changing” for NVIC 4. Modify INIR Description in RTC register 5. Modify description for RTC compensation 6. Revise R/W description for TDR and TCAP 7. Revise description of TWKE 8. Revise description of AER 9. Revise AER effect from 512 clock to 1024 clock 10. Modify ADC analog characteristic spec 11. Modify description of PWM sample procedure 12. Remove the description of TX_FULL and RX_FULL ,and revise TX_POINTER and RX_POINTER 13. Revise the number of UART for NUC100 medium density selection table.



## Important Notice

Nuvoton Products are neither intended nor warranted for usage in systems or equipment, any malfunction or failure of which may cause loss of human life, bodily injury or severe property damage. Such applications are deemed, "Insecure Usage".

Insecure usage includes, but is not limited to: equipment for surgical implementation, atomic energy control instruments, airplane or spaceship instruments, the control or operation of dynamic, brake or safety systems designed for vehicular use, traffic signal instruments, all types of safety devices, and other applications intended to support or sustain life.

All Insecure Usage shall be made at customer's risk, and in the event that third parties lay claims to Nuvoton as a result of customer's Insecure Usage, customer shall indemnify the damages and liabilities thus incurred by Nuvoton.