

W90P710CD/W90P710CDG



32-BIT ARM7TDMI-BASED MCU

W90P710CD/W90P710CDG
16/32-bit ARM microcontroller
Product Data Sheet

W90P710CD/W90P710CDG



Table of Contents-

1.	GENERAL DESCRIPTION	1
2.	FEATURES	2
3.	PIN DIAGRAM	8
4.	PIN ASSIGNMENTS	9
5.	PIN DESCRIPTIONS	15
6.	FUNCTIONAL DESCRIPTION	28
6.1	ARM7TDMI CPU CORE	28
6.2	System Manager	29
6.2.1	Overview	29
6.2.2	System Memory Map	29
6.2.3	Address Bus Generation	32
6.2.4	Data Bus Connection with External Memory	32
6.2.5	Bus Arbitration	41
6.2.6	Power management	42
6.2.7	Power-On Setting	44
6.2.8	System Manager Control Registers Map	45
6.3	External Bus Interface	58
6.3.1	EBI Overview	58
6.3.2	SDRAM Controller	58
6.3.3	EBI Control Registers Map	62
6.4	Cache Controller	80
6.4.1	On-Chip RAM	80
6.4.2	Non-Cacheable Area	80
6.4.3	Instruction Cache	81
6.4.4	Data Cache	83
6.4.5	Write Buffer	85
6.4.6	Cache Control Registers Map	85
6.5	Ethernet MAC Controller	91
6.5.1	EMC Functional Description	91
6.5.2	EMC Register Mapping	102
6.6	GDMA Controller	152
6.6.1	GDMA Functional Description	152
6.6.2	GDMA Register Map	153
6.7	USB Host Controller	161
6.7.1	USB Host Functional Description	161
6.7.2	USB Host Controller Registers Map	162
6.7.3	HCCA	183
6.7.4	Endpoint Descriptor	183
6.7.5	Transfer Descriptor	183
6.8	USB Device Controller	183

W90P710CD/W90P710CDG



6.8.1	USB Endpoints	184
6.8.2	Standard device request.....	184
6.8.3	USB Device Register Description	184
6.9	SD Host Controller.....	220
6.9.1	Functional Description	220
6.9.2	Register Mapping	222
6.9.3	SD Register Description	223
6.10	LCD Controller	237
6.10.1	Main Features	237
6.10.2	LCD Register MAP	238
6.10.3	LCD Special Register Description	240
6.11	Audio Controller	291
6.11.1	IIS Interface	291
6.11.2	AC97 Interface	292
6.11.3	Audio Controller Register Map.....	295
6.12	Universal Asynchronous Receiver/Transmitter Controller	313
6.12.1	UART0.....	315
6.12.2	UART1.....	315
6.12.3	UART2.....	317
6.12.4	UART3.....	319
6.12.5	General UART Controller	320
6.12.6	High speed UART Controller	333
6.13	Timer/Watchdog Controller.....	347
6.13.1	General Timer Controller	347
6.13.2	Watchdog Timer	347
6.13.3	Timer Control Registers Map.....	347
6.14	Advanced Interrupt Controller.....	355
6.14.1	Interrupt Sources	356
6.14.2	AIC Registers Map	359
6.15	General-Purpose Input/Output	371
6.15.1	GPIO Control Registers Map.....	374
6.15.2	GPIO Register Description	375
6.16	Real Time Clock	406
6.16.1	RTC Register Map.....	407
6.16.2	RTC Application Note	420
6.17	Smart Card Host Interface	421
6.17.1	Register Mapping	421
6.17.2	Register Description	423
6.17.3	Functional description.....	448
6.18	I ² C Interface	451
6.18.1	I ² C Protocol	452
6.18.2	I2C Serial Interface Control Registers Map	455

W90P710CD/W90P710CDG



6.19	Universal Serial Interface.....	461
6.19.1	USI Timing Diagram	461
6.19.2	USI Registers Map	462
6.20	PWM	469
6.20.1	PWM double buffering and automatic reload.....	469
6.20.2	Modulate Duty Ratio	470
6.20.3	Dead Zone Generator.....	470
6.20.4	PWM Timer Start procedure.....	471
6.20.5	PWM Timer Stop procedure	471
6.20.6	PWM Register Map	472
6.21	Keypad Interface.....	479
6.21.1	Keypad Interface Register Map	480
6.21.2	Register Description	481
6.22	PS2 Host Interface Controller	488
6.22.1	PS2 Host Controller Interface Register Map.....	489
6.22.2	Register Description	489
7.	ELECTRICAL SPECIFICATIONS.....	493
7.1	Absolute Maximum Ratings	493
7.2	DC Specifications	493
7.2.1	Digital DC Characteristics.....	493
7.2.2	USB Transceiver DC Characteristics.....	495
7.3	AC Specifications.....	495
7.3.1	EBI/SDRAM Interface AC Characteristics	495
7.3.2	EBI/(ROM/SRAM/External I/O) AC Characteristics	496
7.3.3	USB Transceiver AC Characteristics.....	497
7.3.4	EMC RMII AC Characteristics	498
7.3.5	LCD Interface AC Characteristics.....	500
7.3.6	SD Interface AC Characteristics.....	501
7.3.7	AC97/I2S Interface AC Characteristics.....	502
7.3.8	Smart Card Interface AC Characteristics.....	504
7.3.9	I2C Interface AC Characteristics	505
7.3.10	USI Interface AC Characteristics.....	506
7.3.11	PS2 Interface AC Characteristics	507
8.	ORDERING INFORMATION	508
9.	PACKAGE SPECIFICATIONS.....	509
10.	APPENDIX A: W90P710 REGISTERS MAPPING TABLE.....	510
11.	REVISION HISTORY	530

W90P710CD/W90P710CDG



1. GENERAL DESCRIPTION

The W90P710 is built around an outstanding CPU core, the 16/32 ARM7TDMI RISC processor, designed by Advanced RISC Machines, Ltd. It offers 4K-byte I-cache/SRAM and 4K-byte D-cache/SRAM, is a low power, general-purpose integrated circuit. Its simple, elegant, and fully static design is particularly suitable for cost sensitive and power sensitive applications.

One 10/100 Mb MAC of Ethernet controller is built-in to reduce total system cost. An LCD controller is also built-in to support TFT and low cost STN LCD modules.

With one USB 1.1 host controller, one USB 1.1 device controller, two smart card host controllers, four independent UARTs, one Watchdog timer, up to 71 programmable I/O ports, PS/2 keyboard controller and an advanced interrupt controller, the W90P710 is particularly suitable for point-of-sale (POS) system, access control and as a data collector.

The W90P710 also provides one AC97/I²S controller, one SD host controller, one 2-Channel GDMA, two 24-bit timers with 8-bit pre-scale, The external bus interface (EBI) controller provides for SDRAM, ROM/SRAM, flash memory and I/O devices. The System Manager includes an internal 32-bit system bus arbiter and a PLL clock controller. With a wide range of serial communication and Ethernet interfaces, the W90P710 is also suitable for communication gateways as well as many other general-purpose applications.



2. FEATURES

Architecture

- Fully 16/32-bit RISC architecture
- Little/Big-Endian mode supported
- Efficient and powerful ARM7TDMI core
- Cost-effective JTAG-based debug solution

External Bus Interface

- 8/16/32-bit external bus support for ROM/SRAM, flash memory, SDRAM and external I/Os
- Support for SDRAM
- Programmable access cycle (0-7 wait cycle)
- Four-word depth write buffer for SDRAM write data
- Cost-effective memory-to-peripheral DMA interface

Instruction and Data Cache

- Two-way, Set-associative, 4K-byte I-cache and 4K-byte D-cache
- Support for LRU (Least Recently Used) Protocol
- Cache can be configured as internal SRAM
- Support Cache Lock function

Ethernet MAC Controller

- DMA engine with burst mode
- MAC Tx/Rx buffers (256 bytes Tx, 256 bytes Rx)
- Data alignment logic
- Endian translation
- 100/10-Mbit per second operation
- Full compliance with IEEE standard 802.3
- RMII interface only
- Station Management Signaling
- On-Chip CAM (up to 16 destination addresses)
- Full-duplex mode with PAUSE feature
- Long/short packet modes
- PAD generation

W90P710CD/W90P710CDG



LCD Controller (LCDC)

(1) STN LCD Display

- Supports 4-bit single scan Monochrome STN LCD panel, 8-bit single scan Monochrome STN LCD panel, 8-bit single scan Color STN LCD panel
- Up to 16 gray levels display for Monochrome STN LCD panel
- Up to 4096(12bpp) colors display for Color STN LCD panel
- Virtual coloring method: Frame Rate Control (16-level)
- Anti-flickering method: Time-based Dithering

(2) TFT LCD Display

- Supports Sync-type TFT LCD panel and Sync-type High-color TFT LCD panel
- Supports direct or palletized color display

(3) TV Encoder

- Supports 8-bit YCbCr data output format to connect with external TV Encoder

(4) LCD Preprocessing

- Supports RGB Raw-data or YUV422 packet format
- Programmable parameters for different image sizes
- Two built-in FIFOs, FIFO 1 is for Video images and FIFO 2 is for OSD images. Each FIFO is 16 words deep

(5) LCD Post processing

- Support for one OSD (On-Screen-Display) overlay
- Supports various OSD functions
- Programmable parameters for different display panels

(6) Others

- Color-look up table size 256x32 bit for TFT used when displaying 1bpp, 2bpp, 4bpp, 8bpp image
- Dedicated DMA for block transfer mode

DMA Controller

- 2-channel General DMA for memory-to-memory data transfers without CPU intervention
- Initialed by a software or external DMA request
- Increments or decrements a source or destination address in 8-bit, 16-bit or 32-bit data transfers
- 4-data burst mode

UART

- Four UART (serial I/O) blocks with interrupt-based operation
- Support for 5-bit, 6-bit, 7-bit or 8-bit serial data transmission
- Programmable baud rates

W90P710CD/W90P710CDG



- 1, ½ or 2 stop bits
- Odd or even parity
- Break generation and detection
- Parity, overrun and framing error detection
- X16 clock mode
- UART1 supports Bluetooth, and UART2 supports IrDA1.0 SIR

Timers

- Two programmable 24-bit timers with 8-bit prescaler
- One programmable 20-bit timer with optional 8-bit prescaler Watchdog timer
- One-shot mode, periodical mode or toggle mode operation

Programmable I/Os

- 71 programmable I/O ports
- Pins individually configurable for input, output or I/O mode for dedicated signals
- I/O ports are configurable for Multiple functions

Advanced Interrupt Controller

- 31 interrupt sources, including 6 external interrupt sources
- Programmable normal or fast interrupt mode (IRQ, FIQ)
- Programmable as either edge-triggered or level-sensitive for 6 external interrupt sources
- Programmable as either low-active or high-active for 6 external interrupt sources
- Priority methodology is encoded to allow for interrupt daisy-chaining
- Automatically mask out the lower priority interrupt during interrupt nesting

USB Host Controller

- USB 1.1 compliant
- Compatible with Open HCI 1.0 specification
- Supports low-speed and full speed devices
- Built-in DMA for real time data transfer
- Two on-chip USB transceivers with one optionally shared with USB Device Controller

USB Device Controller

- USB 1.1 compliant
- Supports four USB endpoints including one control endpoint and 3 configurable endpoints for rich USB functions

Two PLLs

- The external clock can be multiplied by on-chip PLL to provide high frequency system clock

W90P710CD/W90P710CDG



- The input frequency range is 3-30MHz; 15MHz is preferred.
- One PLL for both CPU and USB host/device controller
- One PLL for LCD pixel clock and audio IIS 12.288/16.934MHz clock source
- Programmable clock frequency

Real Time Clock (RTC)

- 32.768KHz operation
- Time counter (second, minute, hour) and calendar counter (day, month, year)
- Alarm register (second, minute, hour, day, month, year)
- 12 or 24-hour mode selectable
- Automatically recognizes leap years
- Weekday counter
- Frequency compensate register (FCR)
- Besides the FCR, all clock and alarm data are expressed in BCD
- Supports tick time interrupts

4-Channel PWM

- Four 16-bit timers with PWM
- Two 8-bit prescalers & Two 4-bit dividers
- Programmable duty control of output waveform
- Auto reload mode or one-shot pulse mode
- Dead-zone generator

I2C Master

- Two Channel I2C
- Compatible with Philips I²C standard, support master mode only
- Supports multi master operation
- Clock stretching and wait state generation
- Provides multi-byte transmission, up to 4 bytes can be transmitted in a single transfer
- Software programmable acknowledge bit
- Arbitration lost interrupt, with automatic transfer cancellation
- Start/Stop/Repeated Start/Acknowledge generation
- Start/Stop/Repeated Start detection
- Bus busy detection
- Supports 7 bit addressing mode
- Software mode I²C



Universal Serial Interface (USI)

- 1-Channel USI
- Support USI (Microwire/SPI) master mode
- Full duplex synchronous serial data transfer
- Variable length of transfer word up to 32 bits
- Provide burst mode operation, transmit/receive can be executed up to four times in one transfer
- MSB or LSB first data transfer
- Rx and Tx on both positive or negative edge of serial clock independently
- Two slave/device select lines
- Fully static synchronous design with one clock domain

2-Channel AC97/I2S Audio Codec Host Interface

- AHB master port and an AHB slave port are offered in the audio controller.
- 8-beat incrementing burst
- Bus lock during 8-beat incrementing burst
- At the middle or end of a destination address, a DMA_IRQ is automatically requested from the CPU

Smart Card Host Interface (SCH)

- ISO-7816 compliant
- PC/SC T=0, T=1 compliant
- 16-byte transmitter FIFO and 16-byte receiver FIFO
- FIFO threshold interrupt to optimize system performance
- Programmable transmission clock frequency
- Versatile baud rate configuration
- UART-like register file structure
- General-purpose C4, C8 channels

SD Host Interface

- Directly connect to Secure Digital (SD, MMC) flash memory card.
- Supports DMA functions to accelerate the data transfer between the internal buffer, external SDRAM, and flash memory cards.
- Two 512 byte internal buffers are embedded inside the controller.
- No SPI mode.

KeyPad Scan Interface

- Scan up to 16 rows by 8 columns with an external 4 to 16 decoder and 4 rows by 8 columns array without auxiliary components
- Programmable de-bounce time

W90P710CD/W90P710CDG



- One or two keys scan with interrupt and three keys reset function.
- Wakeup CPU from IDEL/Power Down mode

PS2 Host Interface

- APB slave consisted of PS2 protocol.
- Connect IBM keyboard or bar code reader through PS2 interface.
- Provide hardware scan code to ASCII translation

Power management

- Programmable clock enables individual peripherals
- IDLE mode to halt ARM Core and keep peripheral working
- Power-Down mode to stop all clocks included external crystal oscillator.
- Exit IDLE by all interrupts
- Exit Power-Down by keypad, USB device and external interrupts

Operating Voltage Range

- 3.0 ~ 3.6 V for IO Buffer
- 1.62 ~ 1.98 V for Core Logic

Operating Temperature Range

- -40°C ~ +85 °C

Operating Frequency

- Up to 80 MHz

Package Type

- 176-pin LQFP

W90P710CD/W90P710CDG



3. PIN DIAGRAM

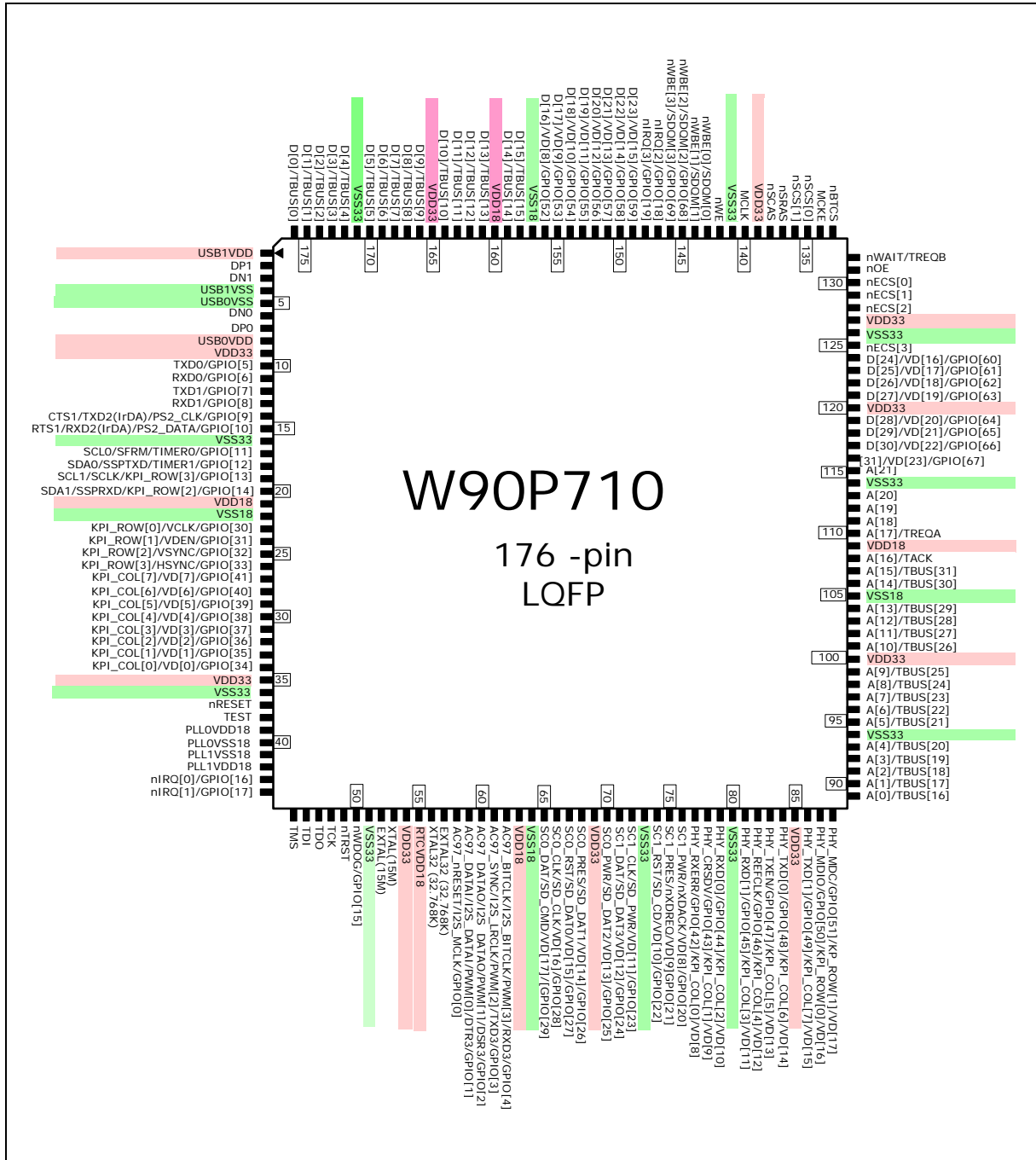

Fig 3.1 Pin Diagram

W90P710CD/W90P710CDG



4. PIN ASSIGNMENTS

Table 4.1 W90P710 Pin Assignments

PIN NAME	176-PIN LQFP
Clock & Reset	(5 pins)
EXTAL (15M)	52
XTAL (15M)	53
EXTAL32 (32.768K)	57
XTAL32 (32.768K)	56
nRESET	37
JTAG Interface	(5 pins)
TMS	45
TDI	46
TDO	47
TCK	48
nTRST	49
External Bus Interface	(72 pins)
A [21]	115
A [20:0]	113-110,108-106, 104-101,99-95, 93-89
D [31:16] / VD [23:8] / GPIO [67:52]	116-119,121-124, 149-156
D [15:0]	158,159,161-164, 166-170,172-176
nWBE [3:2] / SDQM [3:2] / GPIO[69:68]	146,145
nWBE [1:0] / SDQM [1:0]	144,143
nSCS [1:0]	136,135
nSRAS	137
nSCAS	138
MCKE	134
nSWE	142
MCLK	140
nWAIT/ GPIO[70] / nIRQ5	132
nBTCS	133
nECS [3]	125
nECS [2:0]	128-130
nOE	131

W90P710CD/W90P710CDG



Table 4.1 W90P710 Pin Assignments (Continued)

PIN NAME	176-PIN LQFP
Ethernet Interface	(10 pins)
PHY_MDC / GPIO [51] / KPROW[1] / VD[17]	88
PHY_MDIO / GPIO [50] / KPROW[0] / LD[16]	87
PHY_TXD [1:0] / GPIO[49:48] / KPCOL[7:6] / VD[15:14]	86,84
PHY_TXEN / GPIO [47] / KPCOL[5] / VD[13]	83
PHY_REFCLK / GPIO [46] / KPCOL[4] / VD[12]	82
PHY_RXD [1:0] / GPIO [45:44] / KPCOL[3:2] / VD[11:10]	81,79
PHY_CRSDV / GPIO [43] / KPCOL[1] / VD[9]	78
PHY_RXERR / GPIO [42] / KPCOL[0] / VD[8]	77
AC97/I2S/PWM/UART3	(5 pins)
AC97_nRESET / I2S_MCLK / GPIO [0] / USB_PWREN	58

W90P710CD/W90P710CDG



Table 4.1 W90P710 Pin Assignments (Continued)

PIN NAME	176-PIN LQFP
AC97/I2S/PWM/UART3	(5 pins)
AC97_DATAI / I2S_DATAI / PWM [0] / DTR3 / GPIO [1]	59
AC97_DATAO / I2S_DATAO / PWM [1] / DSR3 / GPIO [2]	60
AC97_SYNC / I2S_LRCLK / PWM [2] / TXD3 / GPIO [3]	61
AC97_BITCLK / I2S_BITCLK / PWM [3] / RXD3 GPIO [4]	62
USB Interface	(4 pins)
DP0	7
DN 0	6
DP1	2
DN1	3
Miscellaneous	(7 pins)
nIRQ [3:2] / GPIO [19:18]	148,147
nIRQ [1] / GPIO [17] / USB_OVRCUR	44
nIRQ [0] / GPIO [16]	43
nWDOG / GPIO [15] / USB_PWREN	50
RTCVDD18	55

W90P710CD/W90P710CDG



Table 4.1 W90P710 Pin Assignments (Continued)

NAME	176-PIN LQFP
I2C/USI(Microwire/SPI)	(4 pins)
SCL0 / SFRM / Timer0 / GPIO [11]	17
SDA0 / SSPTXD / Timer1 / GPIO [12]	18
SCL1 / SCLK / GPIO [13] / KPROW[3]	19
SDA1 / SSPRXD / GPIO [14] / KPROW[2]	20
UART0/UART1/UART2/PS2	(6 pins)
TXD0 / GPIO [5]	10
RXD0 / GPIO [6]	11
TXD1 / GPIO [7]	12
RXD1 / GPIO [8]	13
CTS1 / TXD2(IrDA) / PS2_CLK / GPIO [9]	14
RTS1 / RXD2(IrDA) / PS2_DATA / GPIO [10]	15

W90P710CD/W90P710CDG



Table 4.1 W90P710 Pin Assignments (Continued)

NAME	176-PIN LQFP
SCH/SD/XDMA	(10 pins)
SC0_DAT / SD_CMD / GPIO [29] / VD[17]	65
SC0_CLK / SD_CLK / GPIO [28] / VD[16]	66
SC0_RST / SD_DAT0 / GPIO [27] / VD[15]	67
SC0_PRES / SD_DAT1 / GPIO [26] / VD[14]	68
SC0_PWR / SD_DAT2 / GPIO [25] / VD[13]	70
SC1_DAT / SD_DAT3 / GPIO [24] / VD[12]	71
SC1_CLK / GPIO [23] / VD[11]	72
SC1_RST / SD_CD / GPIO [22] / VD[10]	74
SC1_PRES / nXDREQ / GPIO [21] / VD[9]	75
SC1_PWR / nXDACK / GPIO [20] / VD[8]	76

W90P710CD/W90P710CDG



Table 4.1 W90P710 Pin Assignments (Continued)

NAME	176-PIN LQFP
LCDC	(12 pins)
VD[7:0] / GPIO [41:34]/ KPCOL[7:0]	27-34
HSYNC / GPIO [33]/ KPROW[3]	26
VSYNC / GPIO [32]/ KPROW[2]	25
VDEN / GPIO [31]/ KPROW[1]	24
VCLK / GPIO [30]/ KPROW[0]	23
Power/Ground	(36 pins)
VDD18	21,63,109,160
VSS18	22,38,64,105,157
VDD33	9,35,54,69,85,100, 120,127,139,165
VSS33	16,36,51,73,80,94, 114,126,141,171
USBVDD	1,8
USBVSS	4,5
PLLVDD18	39,42
PLLVSS18	40,41



5. PIN DESCRIPTIONS

Table 5.1 W90P710 Pin Descriptions

PIN NAME	IO TYPE	DESCRIPTION
Clock & Reset		
EXTAL (15M)	I	15MHz External Clock / Crystal Input
XTAL (15M)	O	15MHz Crystal Output
EXTAL32(32.768K)	I	32768Hz External Clock / Crystal Input (for RTC)
XTAL32(32.768K)	O	32768Hz Crystal Output (for RTC)
nRESET	IS	System Reset, active-low
JTAG Interface		
TCK	IDS	JTAG Test Clock, internal pull-down with 58K ohm
TMS	IUS	JTAG Test Mode Select, internal pull-up with 70K ohm
TDI	IUS	JTAG Test Data in, internal pull-up with 70K ohm
TDO	O	JTAG Test Data out
nTRST	IUS	JTAG Reset, active-low, internal pull-up with 70K ohm
External Bus Interface		
A [21:18]	O	Address Bus (MSB) of external memory and IO devices.
A [17:0]	IOS	Address Bus of external memory and IO devices.
D [31:16] / VD[23:8] / GPIO [67:52]	IOU	Data Bus (MSB) of external memory and IO device, internal pull-up with 70K ohm. General Programmable In/Out Port GPIO [67:52].
D [15:0] /	IOU	Data Bus (LSB) of external memory and IO device. The internal pull-up resistors are turned on when D[15:0] is in input mode.
nWBE [3:0] / SDQM [3:0] / GPIO[69:68]	IOU	Write Byte Enable for specific device (nECS [3:0]). Data Bus Mask signal for SDRAM (nSCS [1:0]), active-low. General Programmable In/Out Port [69:68]
nSCS [1:0]	O	SDRAM chip select for two external banks, active-low.
nSRAS	O	Row Address Strobe for SDRAM, active-low.
nSCAS	O	Column Address Strobe for SDRAM, active-low.
nSWE	O	SDRAM Write Enable, active-low
MCKE	O	SDRAM Clock Enable, active-high
MCLK	O	System Master Clock Out, SDRAM clock, output with slew-rate control
nWAIT / GPIO[70] / nIRQ5	IOU	External Wait, active-low. This pin indicates that the external devices need more active cycle during access operation. General Programmable In/Out Port GPIO[70]. If memory and IO devices in EBI do not need a wait request, it can be configured as GPIO[7] or nIRQ5
nBTCS	O	ROM/Flash Chip Select, active-low.
nECS [3:0]	O	External I/O Chip Select, active-low.
nOE	O	ROM/Flash, External Memory Output Enable, active-low.

W90P710CD/W90P710CDG



Table 5.1 W90P710 Pin Descriptions (Continued)

PIN NAME	IO TYPE	DESCRIPTION
Ethernet Interface		
PHY_MDC / GPIO [51] / KPROW[1] / VD[17]	IOU	RMII Management Data Clock for Ethernet. It is the reference clock of MDIO. Each MDIO data will be latched at the positive edge of MDC clock. General Programmable In/Out Port [51] Keypad ROW[1] scan output. LCD Pixel Data Output[17].
PHY_MDIO / GPIO [50] / KPROW[0] / VD[16]	IO	RMII Management Data I/O for Ethernet. It is used to transfer RMII control and status information between PHY and MAC. General Programmable In/Out Port [51] Keypad ROW[0] scan output. LCD Pixel Data Output[16].
PHY_TXD [1:0] / GPIO [49:48] / KPCOL[7:6] / VD[15]	IOU	2-bit Transmit Data bus for Ethernet. General programmable In/Out Port [49:48] Keypad Column input [7:6], active low LCD Pixel Data Output[15].
PHY_TXEN / GPIO [47] / KPCOL[5] / VD[14:13]	IOU	PHY_TXEN shall be asserted synchronously with the first 2-bits of the preamble and shall remain asserted while all di-bits to be transmitted present. Of course, it is synchronized with PHY_REFCLK. General Programmable In/Out Port [47] Keypad column input [5], active low LCD Pixel Data Output[14:13].
PHY_REFCLK / GPIO [46] / KPCOL[4] / VD[12]	IOS	Reference Clock. The clock shall be 50MHz +/- 50 ppm with minimum 35% duty cycle at high or low state. General Programmable In/Out port [46] Keypad column input [4], active low LCD Pixel Data Output[12].
PHY_RXD [1:0] / GPIO [45:44] / KPCOL[3:2] / VD[11:10]	IOS	2-bit Receive Data bus for Ethernet. General Programmable In/Out Port [45:44] Keypad column input [3:2], active low LCD Pixel Data Output[11:10].
PHY_CRSDV / GPIO [43] / KPCOL[1] / VD[9]	IOS	Carrier Sense / Receive Data Valid for Ethernet. The PHY_CRSDV shall be asserted by PHY when the receive medium is non-idle. Loss of carrier shall result in the de-assertion of PHY_CRSDV synchronous to the cycle of PHY_REFCLK, and only on 2-bit receive data boundaries. General Programmable In/Out port [43] Keypad column input [1], active low LCD Pixel Data Output[9].
PHY_RXERR / GPIO [42] / KPCOL[0] / VD[8]	IOS	Receive Data Error for Ethernet indicates a data error detected by PHY. The assertion should last longer than the period of PHY_REFCLK. When PHY_RXERR is asserted, the MAC will report a CRC error. General programmable In/Out port [42] Keypad column input [0], active low LCD Pixel Data Output[8].

W90P710CD/W90P710CDG



Table 5.1 W90P710 Pin Descriptions (Continued)

PIN NAME	IO TYPE	DESCRIPTION
AC97/I2S/PWM/UART3		
AC97_nRESET / I2S_MCLK / GPIO [0] / nIRQ4 / USB_PWREN	IOU	AC97 CODEC Host Interface RESET Output. I2S CODEC Host Interface System Clock Output. General Purpose In/Out port [0] External interrupt request. USB host power enable output
AC97_DATAI / I2S_DATAI / PWM [0] / DTR4 / GPIO [1]	IOU	AC97 CODEC Host Interface Data Input. I2S CODEC Host Interface Data Input. PWM Channel 0 Output. Data Terminal Ready for UART4. General Purpose In /Out port [1]
AC97_DATAO / I2S_DATAO / PWM [1] / DSR4 / GPIO [2]	IOU	AC97 CODEC Host Interface Data Output. I2S CODEC Host Interface Data Output. PWM Channel 1 Output. Data Set Ready for UART4. General Purpose In/Out port [2]
AC97_SYNC / I2S_LRCLK / PWM [2] / TXD4 / GPIO [3]	IOU	AC97 CODEC Host Interface Synchronous Pulse Output. I2S CODEC Host Interface Left/Right Channel Select Clock. PWM Channel 2 Output. Transmit Data for UART4. General Purpose In/Out port [3]
AC97_BITCLK / I2S_BITCLK / PWM [3] / RXD4 / GPIO [4]	IOS	AC97 CODEC Host Interface Bit Clock Input. I2S CODEC Host Interface Bit Clock. PWM Channel 3 Output. Receive Data for UART4. General Purpose In/Out port [4].
USB Interface		
DP0	IO	Differential Positive USB IO signal
DN0	IO	Differential Negative USB IO signal
DP1	IO	Differential Positive USB IO signal
DN1	IO	Differential Negative USB IO signal
Miscellaneous		
nIRQ [3:2] / GPIO [19:18]	IOU	External Interrupt Request General Purpose I/O.
nIRQ [1:0] / GPIO [17:16] USB_OVRCUR	IOU	External Interrupt Request General Purpose I/O nIRQ1 is used as USB host over-current detection input
nWDOG / GPIO [15] / USB_PWREN	IOU	Watchdog Timer Timeout Flag and Keypad 3-keys reset output, active low General Purpose In/output USB host power switch enable output
RTCVDD	P	RTC independent battery power (1.8V)

W90P710CD/W90P710CDG



Table 5.1 W90P710 Pin Descriptions (Continued)

PIN NAME	IO TYPE	DESCRIPTION
I2C/USI(Microwire/SPI)		
SCL0 / SFRM / Timer0 / GPIO [11]	IOU	I2C Serial Clock Line 0. USI Serial Frame. Timer0 time out output. General Purpose In/Out port [11].
SDA0 / SSPTXD / Timer1 / GPIO [12]	IOU	I2C Serial Data Line 0 USI Serial Transmit Data Timer1 time out output General Purpose In/Out port [12]
SCL1 / SCLK / GPIO [13] KPROW[3]	IOU	I2C Serial Clock Line 1 USI Serial Clock General Purpose In/Out port [13] Keypad row scan output [3]
SDA1 / SSPRXD / GPIO [14] / KPROW[2]	IDU	I2C Serial Data Line 1 USI Serial Receive Data General Purpose In/Out port [14] Keypad scan output [2]
UART0/UART1/UART2		
TXD0 / GPIO [5]	IOU	UART0 Transmit Data. General Purpose In/Out [5]
RXD0 / GPIO [6]	IOU	UART0 Receive Data. General Purpose In/Out [6]
TXD1 / GPIO [7]	IOU	UART1 Transmit Data. General Purpose In/Out [7]
RXD1 / GPIO [8]	IOU	UART1 Receive Data. General Purpose In/Out [8]
CTS1/ TXD2(IrDA) / PS2_CLK / GPIO [9]	IOU	UART1 Clear To Send for Bluetooth application UART2 Transmit Data supporting SIR IrDA. PS2 Interface Clock Input/Output General Purpose In/Out [9]
RTS1/ RXD2(IrDA) / PS2_DATA / GPIO [10]	IOU	UART1 Request To Send for Bluetooth application UART2 Receive Data supporting SIR IrDA. PS2 Interface Bi-Directional Data Line. General Purpose In/Out [10]
SCH/SD/XDMA		
SC0_DAT/ SD_CMD / GPIO [29] / VD[17]	IOU	Smart Card I/O Contact to Card 0. SD Mode – Command/Response; General Purpose In/Out [29] LCD Pixel Data Output[17].
SC0_CLK / SD_CLK / GPIO [28] / VD[16]	IO	Smart Card Clock Output to Card 0. SD Mode – Clock; General Purpose In/Out [28] LCD Pixel Data Output[16].

W90P710CD/W90P710CDG



Table 5.1 W90P710 Pin Descriptions (Continued)

PIN NAME	IO TYPE	DESCRIPTION
SCHI/SD/XDMA		
SC0_RST / SD_DAT0 / GPIO [27] / VD[15]	IO	Smart Card Reset Output to Card 0. SD Mode – Data Line Bit 0; General Purpose In/Out [27] LCD Pixel Data Output[15].
SC0_PRES / SD_DAT1 / GPIO [26] VD[14]	IO	Smart Card 0 Presence Contact Input. SD Mode – Data Line Bit 1. General Purpose In/Out [26] LCD Pixel Data Output[14].
SC0_nPWR / SD_DAT2 / GPIO [25] / VD[13]	IO	Smart Card 0 Power FET Control Signal Output. SD Mode – Data Line Bit 2. General Purpose In/Out [25] LCD Pixel Data Output[13].
SC1_DAT / SD_DAT3 / GPIO [24] / VD[12]	IO	Smart Card I/O Contact to Card 1. SD Mode – Data Line Bit 3; General Purpose In/Out [24] LCD Pixel Data Output[12].
SC1_CLK / GPIO [23] / VD[11]	IO	Smart Card Clock Output to Card 1. General Purpose In/Out [23] LCD Pixel Data Output[11].
SC1_RST / SD_CD / GPIO [22] / VD[10]	IO	Smart Card Reset Output to Card 1. SD Mode – Card Detect. General Purpose In/Out [22] LCD Pixel Data Output[10].
SC1_PRES / nXDREQ / GPIO [21] / VD[9]	IO	Smart Card 1 Presence Contact Input. External DMA Request. General Purpose In/Out [21] LCD Pixel Data Output[9].
SC1_nPWR / nXDACK / GPIO [20] / VD[8]	IO	Smart Card 1 Power FET Control Signal Output. External DMA Acknowledgement. General Purpose In/Out [20] LCD Pixel Data Output[8].
LCD Interface		
VD [7:0] / GPIO [41:34]/ KPCOL[7:0]	IOU	LCD Pixel Data Output [7:0]. General Purpose In/Out [41:34] Keypad Column input [7:0], active low
HSYNC / GPIO [33]/ KPROW[3]	IOU	Horizontal Sync General Purpose In/Out [33] Keypad ROW[3] scan output.
VSYNC / GPIO [32]/ KPROW[2]	IOU	Vertical Sync General Purpose In/Out [32] Keypad ROW[2] scan output.
VDEN / GPIO [31]/ KPROW[1]	IOU	Data Enable or Display Control Signal. General Purpose In/Out [31] Keypad ROW[1] scan output.

W90P710CD/W90P710CDG



Table 5.1 W90P710 Pins Description (Continued)

PIN NAME	IO TYPE	DESCRIPTION
Power/Ground		
VDD18	P	Core Logic power (1.8V)
VSS18	G	Core Logic ground (0V)
VDD33	P	IO Buffer power (3.3V)
VSS33	G	IO Buffer ground (0V)
USBVDD	P	USB power (3.3V)
USBVSS	G	USB ground (0V)
PLL0_VDD18	P	PLL 0 power (1.8V)
PLL0_VSS18	G	PLL 0 ground (0V)
PLL1_VDD18	P	PLL 1 power (1.8V)
PLL1_VSS18	G	PLL 1 ground (0V)

W90P710CD/W90P710CDG



Table 5.2 W90P710 176-pin LQFP Multi-function List

PIN NO.	DEFAULT	FUNCTION0	FUNCTION1	FUNCTION2	FUNCTION3
USB1.1 Host/Device Interface					
1	USB1VDD	USB1VDD	-	-	-
2	DP1	DP1	-	-	-
3	DN1	DN1	-	-	-
4	USB1VSS	USB1VSS	-	-	-
5	USB0VSS	USB0VSS	-	-	-
6	DN0	DN0	-	-	-
7	DP0	DP0	-	-	-
8	USB0VDD	USB0VDD	-	-	-
9	VDD33	VDD33	-	-	-
UART[2:0]/PS2 Interface					
10	GPIO[5]	GPIO[5]	UART_TXD0	-	-
11	GPIO[6]	GPIO[6]	UART_RXD0	-	-
12	GPIO[7]	GPIO[7]	UART_TXD1	-	-
13	GPIO[8]	GPIO[8]	UART_RXD1	-	-
14	GPIO[9]	GPIO[9]	UART_TXD2	UART_CTS1	PS2_CLK
15	GPIO[10]	GPIO[10]	UART_RXD2	UART_RTS1	PS2_DATA
16	VSS33	VSS33	-	-	-
I2C/USI Interface					
17	GPIO[11]	GPIO[11]	I2C_SCL0	SSP_FRAM	TIMER0
18	GPIO[12]	GPIO[12]	I2C_SDA0	SSP_TXD	TIMER1
19	GPIO[13]	GPIO[13]	I2C_SCL1	SSP_RXD	KPROW[2]
20	GPIO[14]	GPIO[14]	I2C_SDA1	SSP_SCLK	KPROW[3]
21	VDD18	VDD18	-	-	-
22	VSS18	VSS18	-	-	-
LCD /KeyPad Interface					
23	GPIO[30]	GPIO[30]	LCD_VCLK	KPROW[0]	-
24	GPIO[31]	GPIO[31]	LCD_VDEN	KPROW[1]	-
25	GPIO[32]	GPIO[32]	LCD_VSYNC	KPROW[2]	-
26	GPIO[33]	GPIO[33]	LCD_HSYNC	KPROW[3]	-
27	GPIO[41]	GPIO[41]	LCD_VD[7]	KPCOL[7]	-

W90P710CD/W90P710CDG



Table 5.2 W90P710 176-pin LQFP Multi-function List (Continued)

PIN NO.	DEFAULT	FUNCTION0	FUNCTION1	FUNCTION2	FUNCTION3
LCD /Keypad Interface					
28	GPIO[40]	GPIO[40]	LCD_VD[6]	KPCOL[6]	-
29	GPIO[39]	GPIO[39]	LCD_VD[5]	KPCOL[5]	-
30	GPIO[38]	GPIO[38]	LCD_VD[4]	KPCOL[4]	-
31	GPIO[37]	GPIO[37]	LCD_VD[3]	KPCOL[3]	-
32	GPIO[36]	GPIO[36]	LCD_VD[2]	KPCOL[2]	-
33	GPIO[35]	GPIO[35]	LCD_VD[1]	KPCOL[1]	-
34	GPIO[34]	GPIO[34]	LCD_VD[0]	KPCOL[0]	-
35	VDD33	VDD33	-	-	-
36	VSS33	VSS33	-	-	-
System Reset					
37	nRESET	nRESET	-	-	-
38	VSS33	VSS33	-	-	-
PLL Power/Ground					
39	PLL0_VDD18	PLL0_VDD18	-	-	-
40	PLL0_VSS18	PLL0_VSS18	-	-	-
41	PLL1_VSS18	PLL1_VSS18	-	-	-
42	PLL1_VDD18	PLL1_VDD18	-	-	-
External IRQ[1:0]/USB Over Current					
43	GPIO[16]	GPIO[16]	nIRQ[0]	-	-
44	GPIO[17]	GPIO[17]	nIRQ[1]	USB_OVRCUR	-
JTAG Interface					
45	TMS	TMS	-	-	-
46	TDI	TDI	-	-	-
47	TDO	TDO	-	-	-
48	TCK	TCK	-	-	-
49	nTRST	nTRST	-	-	-
Watchdog/USB Power Enable					
50	GPIO[15]	GPIO[15]	nWDOG	USB_PWREN	-
51	VSS33	VSS33	-	-	-

W90P710CD/W90P710CDG



Table 5.2 W90P710 176-pin LQFP Multi-function List (Continued)

PIN NO.	DEFAULT	FUNCTION0	FUNCTION1	FUNCTION2	FUNCTION3
System/RTC Clock					
52	EXTAL(15M)	EXTAL(15M)	-	-	-
53	XTAL(15M)	XTAL(15M)	-	-	-
54	VDD33	VDD33	-	-	-
55	RTCVDD18	RTCVDD18	-	-	-
56	XTAL32 (32K)	XTAL32 (32K)	-	-	-
57	EXTAL32 (32K)	EXTAL32 (32K)	-	-	-
AC97/I2S/PWM/UART3 Interface					
58	GPIO[0]	GPIO[0]	AC97_nRESET	IRQ4	USB_PWREN
59	GPIO[1]	GPIO[1]	AC97_DATAI	PWM0	UART_DTR3
60	GPIO[2]	GPIO[2]	AC97_DATAO	PWM1	UART_DSR3
61	GPIO[3]	GPIO[3]	AC97_SYNC	PWM2	UART_TXD3
62	GPIO[4]	GPIO[4]	AC97_BITCLK	PWM3	UART_RXD3
63	VDD18	VDD18	-	-	-
64	VSS18	VSS18	-	-	-
Smartcard/SD/USB Power/XDMAREQ/LCD Interface					
65	GPIO[29]	GPIO[29]	SD_CMD	SC0_IO	LCD_VD[17]
66	GPIO[28]	GPIO[28]	SD_CLK	SC0_CLK	LCD_VD[16]
67	GPIO[27]	GPIO[27]	SD_DAT[0]	SC0_RST	LCD_VD[15]
68	GPIO[26]	GPIO[26]	SD_DAT[1]	SC0_PRES	LCD_VD[14]
69	VDD33	VDD33			
70	GPIO[25]	GPIO[25]	SD_DAT[2]	SC0_PWR	LCD_VD[13]
71	GPIO[24]	GPIO[24]	SD_DAT[3]	SC1_IO	LCD_VD[12]
72	GPIO[23]	GPIO[23]	USBPWREN	SC1_CLK	LCD_VD[11]
73	VSS33	VSS33			
74	GPIO[22]	GPIO[22]	SD_CD	SC1_RST	LCD_VD[10]
75	GPIO[21]	GPIO[21]	nXQREQ	SC1_PRES	LCD_VD[9]
76	GPIO[20]	GPIO[20]	nXDACK	SC1_PWR	LCD_VD[8]

W90P710CD/W90P710CDG



Table 5.2 W90P710 176-pin LQFP Multi-function List (Continued)

PIN NO.	DEFAULT	FUNCTION0	FUNCTION1	FUNCTION2	FUNCTION3
Ethernet RMI/Keypad Interface					
77	GPIO[42]	GPIO[42]	PHY_RXERR	KPCOL[0]	LCD_VD[8]
78	GPIO[43]	GPIO[43]	PHY_CRSDV	KPCOL[1]	LCD_VD[9]
79	GPIO[44]	GPIO[44]	PHY_RXD[0]	KPCOL[2]	LCD_VD[10]
80	VSS33	VSS33	-	-	-
81	GPIO[45]	GPIO[45]	PHY_RXD[1]	KPCOL[3]	LCD_VD[11]
82	GPIO[46]	GPIO[46]	PHY_REFCLK	KPCOL[4]	LCD_VD[12]
83	GPIO[47]	GPIO[47]	PHY_TXEN	KPCOL[5]	LCD_VD[13]
84	GPIO[48]	GPIO[48]	PHY_TXD[0]	KPCOL[6]	LCD_VD[14]
85	VDD33	VDD33	-	-	-
86	GPIO[49]	GPIO[49]	PHY_TXD[1]	KPCOL[7]	LCD_VD[15]
87	GPIO[50]	GPIO[50]	PHY_MDIO	KPROW[0]	LCD_VD[16]
88	GPIO[51]	GPIO[51]	PHY_MDC	KPROW[1]	LCD_VD[17]
Memory Address/Data/Control					
89	A[0]	A[0]	-	-	-
90	A[1]	A[1]	-	-	-
91	A[2]	A[2]	-	-	-
92	A[3]	A[3]	-	-	-
93	A[4]	A[4]	-	-	-
94	VSS33	VSS33	-	-	-
95	A[5]	A[5]	-	-	-
96	A[6]	A[6]	-	-	-
97	A[7]	A[7]	-	-	-
98	A[8]	A[8]	-	-	-
99	A[9]	A[9]	-	-	-
100	VDD33	VDD33	-	-	-
101	A[10]	A[10]	-	-	-
102	A[11]	A[11]	-	-	-
103	A[12]	A[12]	-	-	-
104	A[13]	A[13]	-	-	-

W90P710CD/W90P710CDG



Table 5.2 W90P710 176-pin LQFP Multi-function List (Continued)

PIN NO.	DEFAULT	FUNCTION0	FUNCTION1	FUNCTION2	FUNCTION3
Memory Address/Data/Control					
105	VSS18	VSS18	-	-	-
106	A[14]	A[14]	-	-	-
107	A[15]	A[15]	-	-	-
108	A[16]	A[16]	-	-	-
109	VDD18	VDD18	-	-	-
110	A[17]	A[17]	-	-	-
111	A[18]	A[18]	-	-	-
112	A[19]	A[19]	-	-	-
113	A[20]	A[20]	-	-	-
114	VSS33	VSS33	-	-	-
115	A[21]	A[21]	-	-	-
116	D[31]	GPIO[67]	D[31]	LCD_VD[23]	-
117	D[30]	GPIO[66]	D[30]	LCD_VD[22]	-
118	D[29]	GPIO[65]	D[29]	LCD_VD[21]	-
119	D[28]	GPIO[64]	D[28]	LCD_VD[20]	-
120	VDD33	VDD33	-	-	-
121	D[27]	GPIO[63]	D[27]	LCD_VD[19]	-
122	D[26]	GPIO[62]	D[26]	LCD_VD[18]	-
123	D[25]	GPIO[61]	D[25]	LCD_VD[17]	-
124	D[24]	GPIO[60]	D[24]	LCD_VD[16]	-
125	nECS[3]	nECS[3]	-	-	-
126	VSS33	VSS33	-	-	-
127	VDD33	VDD33	-	-	-
128	nECS[2]	nECS[2]	-	-	-
129	nECS[1]	nECS[1]	-	-	-
130	nECS[0]	nECS[0]	-	-	-
131	nOE	nOE	-	-	-
132	nWAIT	GPIO[71]	nWAIT	IRQ5	-
133	nBTCS	nBTCS	-	-	-
134	MCKE	MCKE	-	-	-

W90P710CD/W90P710CDG



Table 5.2 W90P710 176-pin LQFP Multi-function List (Continued)

PIN NO.	DEFAULT	FUNCTION0	FUNCTION1	FUNCTION2	FUNCTION3
Memory Address/Data/Control					
135	nSCS[0]	nSCS[0]	-	-	-
136	nSCS[1]	nSCS[1]	-	-	-
137	nSRAS	nSRAS	-	-	-
138	nSCAS	nSCAS	-	-	-
139	VDD33	VDD33	-	-	-
140	MCLK	MCLK	-	-	-
141	VSS33	VSS33	-	-	-
142	nWE	nWE	-	-	-
143	nWBE_SDQM[0]	nWBE_SDQM[0]	-	-	-
144	nWBE_SDQM[1]	nWBE_SDQM[1]	-	-	-
145	nWBE_SDQM[2]	GPIO[68]	nWBE_SDQM[2]	-	-
146	nWBE_SDQM[3]	GPIO[69]	nWBE_SDQM[3]	-	-
147	GPIO[18]	GPIO[18]	nIRQ[2]	-	-
148	GPIO[19]	GPIO[19]	nIRQ[3]	-	-
149	GPIO[59]	GPIO[59]	D[23]	LCD_VD[15]	-
150	D[22]	GPIO[58]	D[22]	LCD_VD[14]	-
151	D[21]	GPIO[57]	D[21]	LCD_VD[13]	-
152	D[20]	GPIO[56]	D[20]	LCD_VD[12]	-
152	D[20]	GPIO[56]	D[20]	LCD_VD[12]	-
153	D[19]	GPIO[55]	D[19]	LCD_VD[11]	-
154	D[18]	GPIO[54]	D[18]	LCD_VD[10]	-
155	D[17]	GPIO[53]	D[17]	LCD_VD[9]	-
156	D[16]	GPIO[52]	D[16]	LCD_VD[8]	-
157	VSS18	VSS18	-	-	-
158	D[15]	D[15]	-	-	-
159	D[14]	D[14]	-	-	-
160	VDD18	VDD18	-	-	-
161	D[13]	D[13]	-	-	-
162	D[12]	D[12]	-	-	-

W90P710CD/W90P710CDG



Table 5.2 W90P710 176-pin LQFP Multi-function List (Continued)

PIN NO.	DEFAULT	FUNCTION0	FUNCTION1	FUNCTION2	FUNCTION3
Memory Address/Data/Control					
163	D[11]	D[11]	-	-	-
164	D[10]	D[10]	-	-	-
165	VDD33	VDD33	-	-	-
166	D[9]	D[9]	-	-	-
167	D[8]	D[8]	-	-	-
168	D[7]	D[7]	-	-	-
169	D[6]	D[6]	-	-	-
170	D[5]	D[5]	-	-	-
171	VSS33	VSS33	-	-	-
172	D[4]	D[4]	-	-	-
173	D[3]	D[3]	-	-	-
174	D[2]	D[2]	-	-	-
175	D[1]	D[1]	-	-	-
176	D[0]	D[0]	-	-	-



6. FUNCTIONAL DESCRIPTION

6.1 ARM7TDMI CPU CORE

The ARM7TDMI CPU core is a member of the Advanced RISC Machine (ARM) family of general-purpose 32-bit microprocessors, offering high performance for very low power consumption. The architecture is based on Reduced Instruction Set Computer (RISC) principles, and the instruction set and related decode mechanism are much simpler than those of micro-programmed Complex Instruction Set Computers. Pipelining is employed so that all parts of the processing and memory systems can operate continuously. High instruction throughput and impressive real-time interrupt response are the major benefits.

The ARM7TDMI CPU core has two instruction sets:

- (1) The standard 32-bit ARM set
- (2) A 16-bit THUMB set

The THUMB set's 16-bit instruction length allows it to approach twice the density of standard ARM core while retaining most of ARM's performance advantage over a traditional 16-bit processor using 16-bit registers. THUMB instructions operate with the standard ARM register configuration, allowing excellent interoperability between ARM and THUMB states. Each 16-bit THUMB instruction has a corresponding 32-bit ARM instruction with the same effect on the processor model.

ARM7TDMI CPU core has 31 x 32-bit registers. At any one time, 16 sets are visible; the other registers are used to speed up exception processing. All registers specified in ARM instructions can address any of the 16 registers. The CPU also supports 5 types of exception, such as two levels of interrupt, memory aborts, attempted execution of an undefined instruction, and software interrupts.

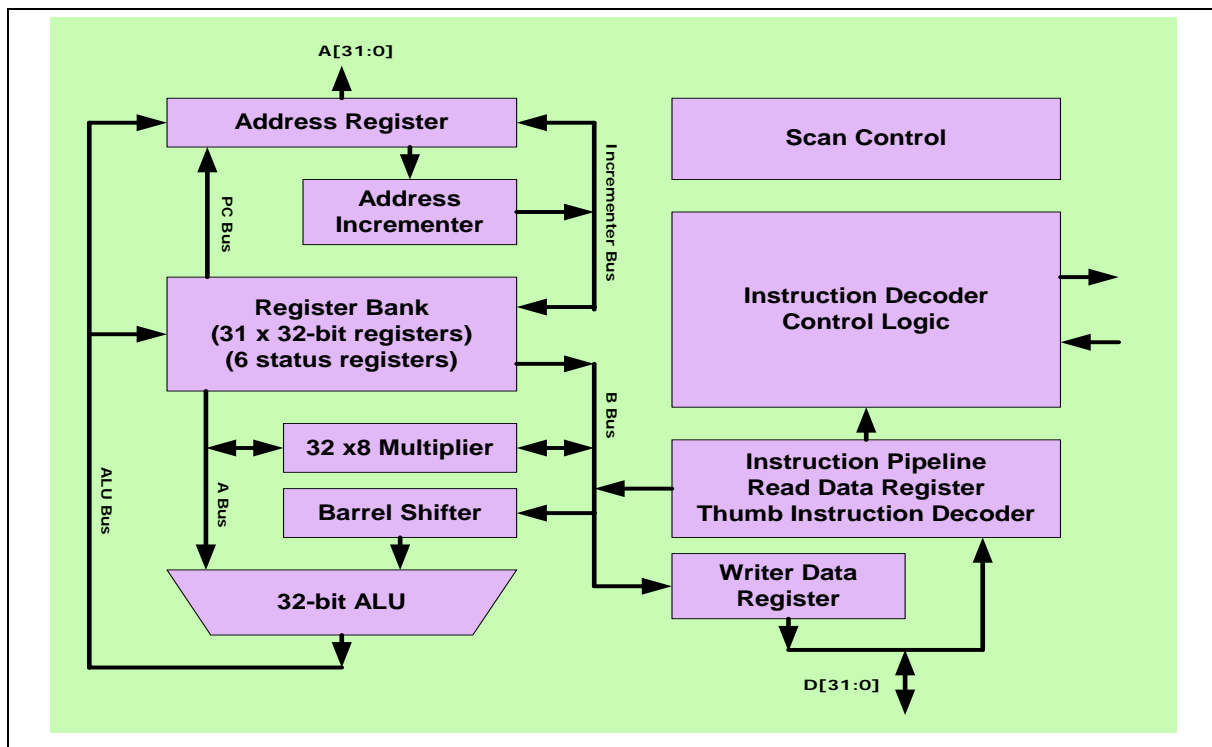

Fig 6.1 ARM7TDMI CPU Core Block Diagram



6.2 System Manager

6.2.1 Overview

The W90P710 System Manager has the following functions.

- System memory map
- Data bus connection with external memory
- Product identifier register
- Bus arbitration
- PLL module
- Clock select and power saving control register
- Power-On setting

6.2.2 System Memory Map

W90P710 provides 2G bytes cacheable address space and the other 2G bytes are non-cacheable. The On-Chip Peripherals bank is on 1M bytes top of the space (0xFFFF_0000 – 0xFFFF_FFFF) and the On-Chip RAM bank's start address is 0xFFE0_0000, the other banks can be located anywhere (cacheable space: 0x0000_0000 ~ 0x7FDF_FFFF if Cache ON; non-cacheable space: 0x8000_0000 ~ 0xFFDF_FFFF).

The size and location of each bank is determined by the register settings for "current bank base address pointer" and "current bank size". Please note that when setting the bank control registers, the address boundaries of consecutive banks must not overlap.

Except for On-Chip Peripherals and On-Chip RAM, the start address of each memory bank is not fixed. You can use bank control registers to assign a specific bank start address by setting the bank's base pointer (13 bits). The address resolution is 256K bytes. The bank's start address is defined as "base pointer << 18" and the bank's size is "current bank size".

In the event of an access requested to an address outside any programmed bank size, an abort signal is generated. The maximum accessible memory size of each external IO bank is 16M bytes (by word format), and 64M bytes on each SDRAM bank.

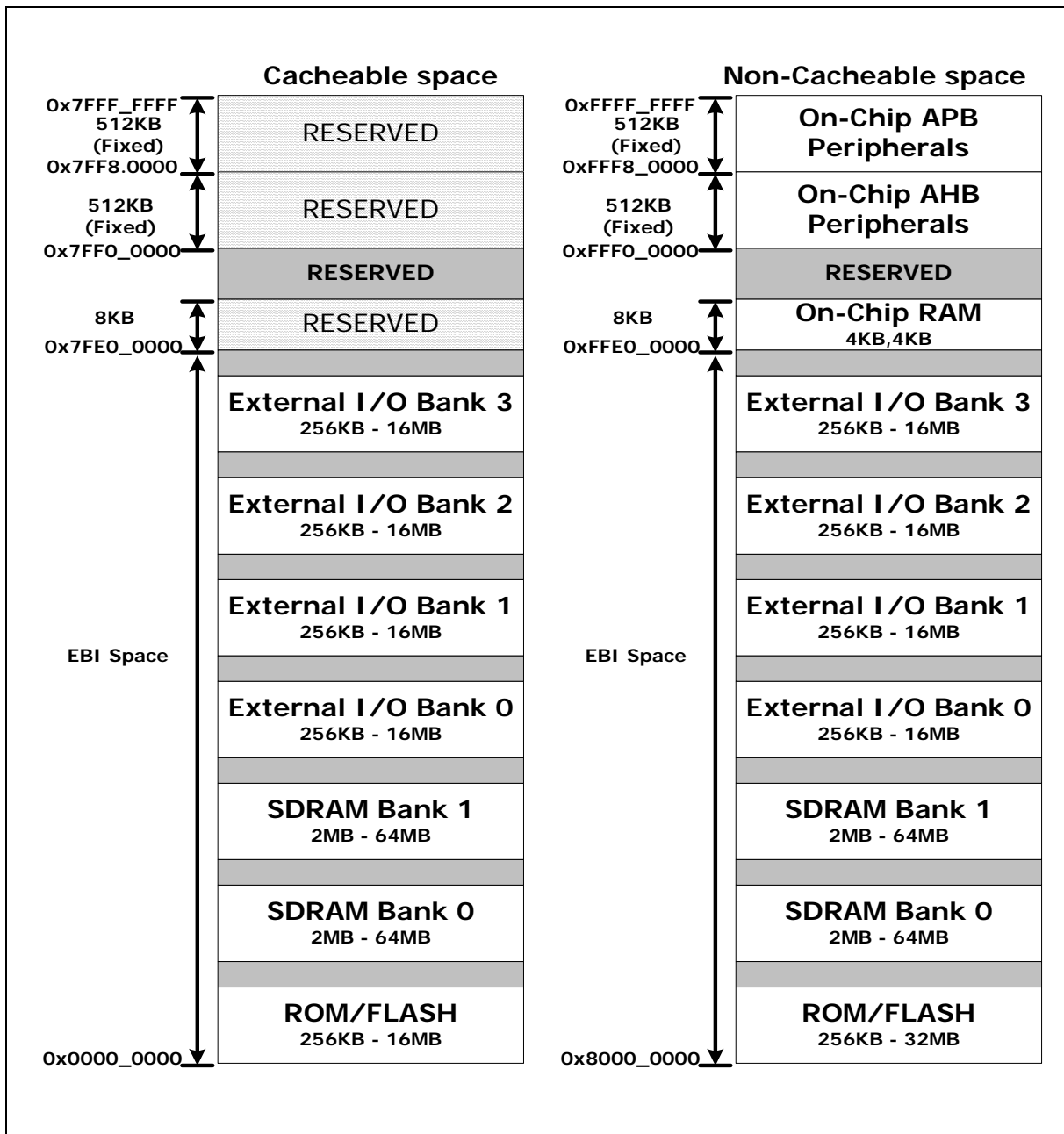

Fig6.2.1 System Memory Map



Table 6.2.1 On-Chip Peripherals Memory Map

BASE ADDRESS	DESCRIPTION
AHB Peripherals	
0xFFFF0_0000	Product Identifier Register (PDID)
0xFFFF0_0004	Arbitration Control Register (ARBCON)
0xFFFF0_0008	PLL Control Register 0(PLLCON0)
0xFFFF0_000C	Clock Select Register (CLKSEL)
0xFFFF0_0010	PLL Control Register 1 (PLLCON1)
0xFFFF0_0014	Audio IIS Clock Control Register (I2SCKCON)
0xFFFF0_0020	IRQ Wakeup Control Register (IRQWAKEUPCON)
0xFFFF0_0024	IRQ Wakeup Flag Register (IRQWAKEFLAG)
0xFFFF0_0028	Power Manager Control Register (PMCON)
0xFFFF0_0030	USB Transceiver Control Register (USBTXRCON)
0xFFFF0_1000	EBI Control Register (EBICON) Control Registers
0xFFFF0_1004	ROM/FLASH (ROMCON) Control Registers
0xFFFF0_1008	SDRAM bank 0 – 1 Control Registers
0xFFFF0_1018	External I/O 0 – 3 Control Registers
0xFFFF0_2000	Cache Controller Control Registers
0xFFFF0_3000	Ethernet MAC Controller Control Registers
0xFFFF0_4000	GDMA 0 – 1 Control Registers
0xFFFF0_5000	USB Host Controller Control Registers
0xFFFF0_6000	USB Device Controller Control Registers
0xFFFF0_7000	SD Host Controller Control Registers
0xFFFF0_8000	LCD Controller Control Registers
0xFFFF0_9000	AC97/I2S Controller Control Registers
APB Peripherals	
0xFFFF8_0000	UART 0 (Tx, Rx for console)
0xFFFF8_0100	UART 1 (Tx, Rx, for Bluetooth)
0xFFFF8_0200	UART 2 (Bluetooth CTS, RTS/ IrDA Tx, Rx)
0xFFFF8_0300	UART 3 (micro-print DTR, DTS, Tx, Rx)
0xFFFF8_1000	Timer 0 – 1, WDOG Timer
0xFFFF8_2000	Interrupt Controller
0xFFFF8_3000	GPIO
0xFFFF8_4000	Real Time Clock Controller Control Registers (RTC)
0xFFFF8_5000	Smart Card Host Interface Control Registers (SCH1)
0xFFFF8_6000	I2C-0 Control Registers
0xFFFF8_6100	I2C-1 Control Registers
0xFFFF8_6200	USI Control Registers

W90P710CD/W90P710CDG



Table 6.2.1 On-Chip Peripherals Memory Map (Continued)

BASE ADDRESS	DESCRIPTION
APB Peripherals	
0xFFF8_7000	Pulse Width Modulation (PWM) Control Registers
0xFFF8_8000	Keypad Interface Control Register (KPI)
0xFFF8_9000	PS2 Control Registers

6.2.3 Address Bus Generation

The W90P710 address bus generation depends on the required data bus width of each memory bank. The data bus width is determined by **DBWD** bits in each bank's control register.

The maximum accessible memory size of each external IO bank is 16M bytes.

Table 6.2.2 Address Bus Generation Guidelines

DATA BUS WIDTH	EXTERNAL ADDRESS PINS	MAXIMUM ACCESSIBLE MEMORY SIZE
	A [21:0]	
8-bit	A21 – A0 (Internal)	4M bytes
16-bit	A22 – A1 (Internal)	4M half-words
32-bit	A23 – A2 (Internal)	4M words

6.2.4 Data Bus Connection with External Memory

6.2.4.1 Memory formats

The W90P710 can be configured to operate in big-endian or little-endian via pull-up or pull-down register on the external data bus, pin D14. If D14 is pulled up then little-endian is used, otherwise, big-endian mode is set.

Little-endian

In little-endian format, the lowest addressed byte in a word is considered the least significant byte of the word and the highest addressable byte is the most significant. So the byte at address 0 of the memory system connects to data lines 7 through 0.

For a word aligned address A, Fig6.2.2 shows how the word at address A, the half-word at addresses A and A+2, and the bytes at addresses A, A+1, A+2, and A+3 map to each other when pin **D14** is High.

31	30	29	28	27	26	25	24	23	22	21	20	19	18	17	16	15	14	13	12	11	10	9	8	7	6	5	4	3	2	1	0
Word at address A																															
Half-word at address A+2																Half-word at address A															
Byte at address A+3								Byte at address A+2								Byte at address A+1								Byte at address A							

Fig6.2.2 Little-endian addresses of bytes and half-words within words

W90P710CD/W90P710CDG



Big-endian

In Big-endian format, W90P710 stores the most significant byte of a word at the lowest numbered byte, and the least significant byte at the highest-numbered byte. So the byte at address 0 of the memory system connects to data lines 31 through 24.

For a word aligned address A, Fig6.2.3 shows how the word at address A, the half-word at addresses A and A+2, and the bytes at addresses A, A+1, A+2, and A+3 map to each other when pin **D14** is Low.

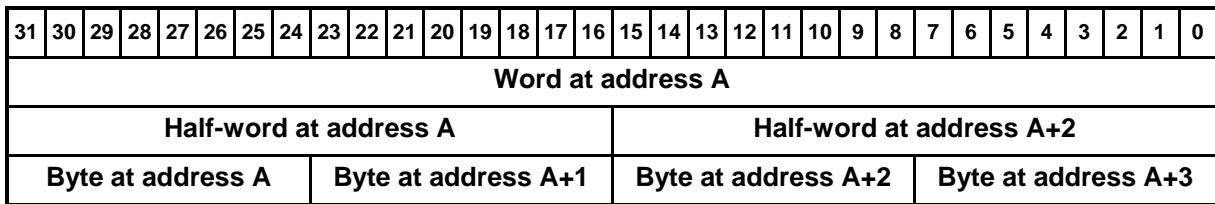

Fig6.2.3 Big-endian addresses of bytes and half-words within words

6.2.4.2 Connecting External Memory of Various Data Widths

The system diagram for connecting W90P710 to external memory is shown in Fig6.2.4. The following tables (Table6.2.3 through Table6.2.14) show the program/data path between CPU register and external memory using little / big-endian and word/half-word/byte access.

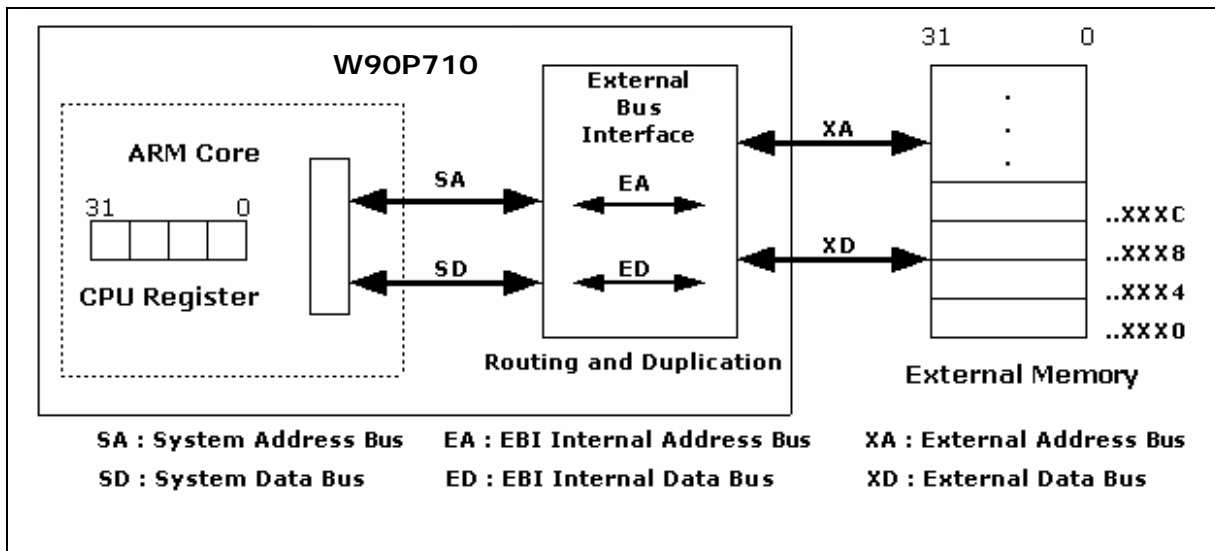

Fig6.2.4 Address/Data bus connection with external memory

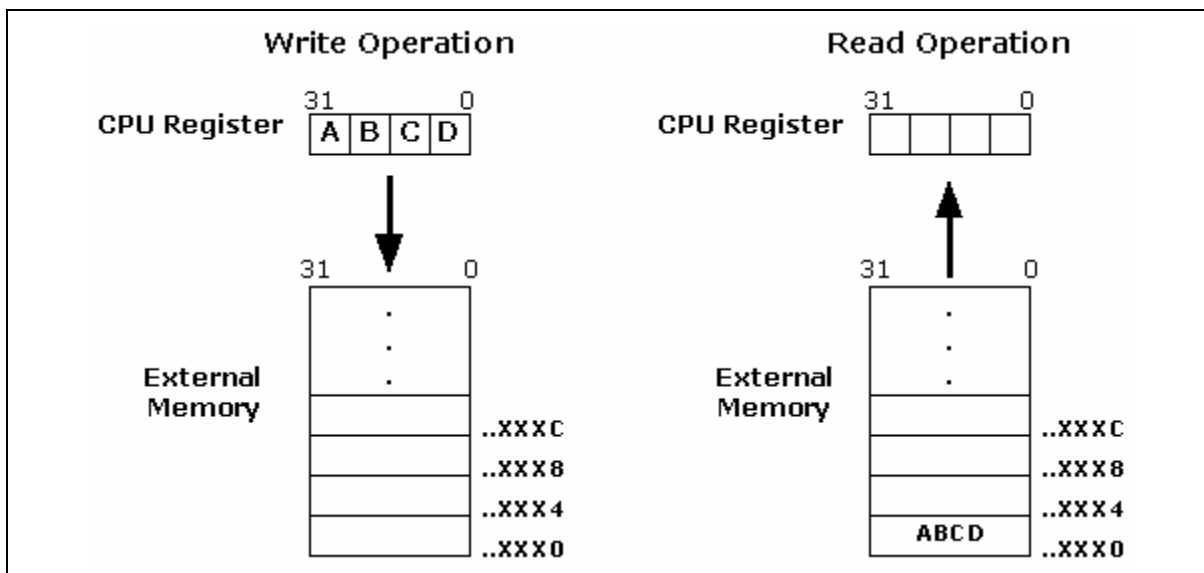

Fig6.2.5 CPU registers Read/Write with external memory

Table 6.2.3 and Table 6.2.4

Using big-endian and word access, Program/Data path between register and external memory

WA = Address whose LSB is 0,4,8,C X = Don't care

nWBE [3-0] / SDQM [3-0] = A means active and U means inactive

Table6.2.3 Word access write operation with big endian

ACCESS OPERATION	WRITE OPERATION (CPU REGISTER → EXTERNAL MEMORY)						
	WORD	HALF WORD		BYTE			
Bit Number CPU Reg Data	31 0 ABCD	31 0 ABCD		31 0 ABCD			
SA	WA	WA		WA			
Bit Number SD	31 0 ABCD	31 0 AB CD		31 0 A B C D			
Bit Number ED	31 0 ABCD	15 0 AB	15 0 CD	7 0 A	7 0 B	7 0 C	7 0 D
XA	WA	WA	WA+2	WA	WA+1	WA+2	WA+3
nWBE [3-0] / SDQM [3-0]	AAAA	XXAA	XXAA	XXA	XXA	XXA	XXA
Bit Number XD	31 0 ABCD	15 0 AB	15 0 CD	7 0 A	7 0 B	7 0 C	7 0 D
Bit Number Ext. Mem Data	31 0 ABCD	15 0 AB	15 0 CD	7 0 A	7 0 B	7 0 C	7 0 D
Timing Sequence		1st write	2nd write	1st write	2nd write	3rd write	4th write

W90P710CD/W90P710CDG



Table6.2.4 Word access read operation with big endian

ACCESS OPERATION	READ OPERATION (CPU REGISTER ← EXTERNAL MEMORY)						
	WORD	HALF WORD		BYTE			
Bit Number CPU Reg Data	31 0 ABCD	31 0 CDAB		31 0 DCBA			
SA	WA	WA		WA			
Bit Number SD	31 0 ABCD	31 0 CD AB		31 0 D C B A			
Bit Number ED	31 0 ABCD	31 0 CD XX	31 0 CD AB	31 0 D X X X	31 0 D C X X	31 0 D C B X	31 0 D C B A
XA	WA	WA	WA+2	WA	WA+1	WA+2	WA+3
SDQM [3-0]	AAAA	XXAA	XXAA	XXXA	XXXA	XXXA	XXXA
Bit Number XD	31 0 ABCD	15 0 CD	15 0 AB	7 0 D	7 0 C	7 0 B	7 0 A
Bit Number Ext. Mem Data	31 0 ABCD	15 0 CD	15 0 AB	7 0 D	7 0 C	7 0 B	7 0 A
Timing Sequence		1st read	2nd read	1st read	2nd read	3rd read	4th read

Table 6.2.5 and Table 6.2.6

Using big-endian and half-word access, Program/Data path between register and external memory.

HA = Address whose LSB is 0,2,4,6,8,A,C,E HAL = Address whose LSB is 0,4,8,C

HAU = Address whose LSB is 2,6,A,E X = Don't care

nWBE [3-0] / SDQM [3-0] = A means active and U means inactive

Table6.2.5 Half-word access write operation with big endian

ACCESS OPERATION	WRITE OPERATION (CPU REGISTER → EXTERNAL MEMORY)				
	WORD	HALF WORD		BYTE	
Bit Number CPU Reg Data	31 0 ABCD	31 0 ABCD		31 0 ABCD	
SA	HAL	HAU	HA	HA	
Bit Number SD	31 0 CD CD	31 0 CD CD	31 0 CD CD	31 0 CD CD	31 0 CD CD
Bit Number ED	31 0 CD CD	31 0 CD CD	31 0 CD CD	7 0 C	7 0 D
XA	HAL	HAL	HA	HA	HA+1
nWBE [3-0] / SDQM [3-0]	AAUU	UUAA	XXAA	XXXA	XXXA
Bit Number XD	31 0 CD CD	31 0 CD CD	15 0 CD	7 0 C	7 0 D
Bit Number Ext. Mem Data	31 16 CD	15 0 CD	15 0 CD	7 0 C	7 0 D
Timing Sequence				1st write	2nd write

W90P710CD/W90P710CDG



Table6.2.6 Half-word access read operation with big endian

ACCESS OPERATION	READ OPERATION (CPU REGISTER ← EXTERNAL MEMORY)				
	XD WIDTH	WORD		HALF WORD	BYTE
Bit Number CPU Reg Data	15 0 AB	15 0 CD	15 0 CD	15 0 DC	
SA	HAL	HAU	HA	HA	
Bit Number SD	15 0 AB	15 0 CD	15 0 CD	15 0 DC	
Bit Number ED	15 0 AB	15 0 CD	15 0 CD	15 0 DX	15 0 DC
XA	HAL	HAL	HA	HA	HA+1
SDQM [3-0]	AAUU	UUAA	XXAA	XXXA	XXXA
Bit Number XD	31 0 AB CD	31 0 AB CD	15 0 CD	7 0 D	7 0 C
Bit Number Ext. Mem Data	31 0 ABCD		15 0 CD	7 0 D	7 0 C
Timing Sequence				1st read	2nd read

Table 6.2.7 and Table 6.2.8

Using big-endian and byte access, Program/Data path between register and external memory.

BA = Address whose LSB is 0,1,2,3,4,5,6,7,8,9,A,B,C,D,E,F

BAL = Address whose LSB is 0,2,4,6,8,A,C,E BAU = Address whose LSB is 1,3,5,7,9,B,D,F

BA0 = Address whose LSB is 0,4,8,C BA1 = Address whose LSB is 1,5,9,D

BA2 = Address whose LSB is 2,6,A,E BA3 = Address whose LSB is 3,7,B,F

W90P710CD/W90P710CDG



Table6.2.7 Byte access write operation with big endian

ACCESS OPERATION	WRITE OPERATION (CPU REGISTER → EXTERNAL MEMORY)						
XD WIDTH	WORD				HALF-WORD		BYTE
Bit Number CPU Reg Data	31 0 ABCD				31 0 ABCD		31 0 ABCD
SA	BA0	BA1	BA2	BA3	BAL	BAU	BA
Bit Number SD	31 0 D D D D	31 0 D D D D	31 0 D D D D	31 0 D D D D	31 0 D D D D	31 0 D D D D	31 0 D D D D
Bit Number ED	31 24 D	23 16 D	15 8 D	7 0 D	15 8 D	7 0 D	7 0 D
XA	BA0	BA0	BA0	BA0	BAL	BAL	BA
nWBE [3-0] / SDQM [3-0]	AUUU	UAUU	UUAU	UUUA	XXAU	XXUA	XXXX
Bit Number XD	31 0 D X X X	31 0 X D X X	31 0 X X D X	31 0 X X X D	15 0 D X	15 0 X D	7 0 D
Bit Number Ext. Mem Data	31 24 D	23 16 D	15 8 D	7 0 D	15 8 D	7 0 D	7 0 D
Timing Sequence							

Table6.2.8 Byte access read operation with big endian

ACCESS OPERATION	READ OPERATION (CPU REGISTER ← EXTERNAL MEMORY)						
XD WIDTH	WORD				HALF WORD		BYTE
Bit Number CPU Reg Data	7 0 A	7 0 B	7 0 C	7 0 D	7 0 C	7 0 D	7 0 D
SA	BA0	BA1	BA2	BA3	BAL	BAU	BA
Bit Number SD	7 0 A	7 0 B	7 0 C	7 0 D	7 0 C	7 0 D	7 0 D
Bit Number ED	7 0 A	15 8 B	23 16 C	31 24 D	7 0 C	15 8 D	7 0 D
XA	BA0	BA0	BA0	BA0	BAL	BAL	BA
SDQM [3-0]	AUUU	UAUU	UUAU	UUUA	XXAU	XXUA	XXXX
Bit Number XD	31 0 ABCD	31 0 ABCD	31 0 ABCD	31 0 ABCD	15 0 CD	15 0 CD	7 0 D
Bit Number Ext. Mem Data	31 0 ABCD				15 0 CD		7 0 D
Timing Sequence							

W90P710CD/W90P710CDG



Table 6.2.9 and Table 6.2.10

Using little-endian and word access, Program/Data path between register and external memory

WA = Address whose LSB is 0,4,8,C X = Don't care

nWBE [3-0] / SDQM [3-0] = A means active and U means inactive

Table6.2.9 Word access write operation with little endian

ACCESS OPERATION	WRITE OPERATION (CPU REGISTER → EXTERNAL MEMORY)						
	WORD	HALF WORD		BYTE			
Bit Number CPU Reg Data	31 0 ABCD	31 0 ABCD		31 0 ABCD			
SA	WA	WA		WA			
Bit Number SD	31 0 ABCD	31 0 AB CD		31 0 A B C D			
Bit Number ED	31 0 ABCD	15 0 CD	15 0 AB	7 0 D	7 0 C	7 0 B	7 0 A
XA	WA	WA	WA+2	WA	WA+1	WA+2	WA+3
nWBE [3-0] / SDQM [3-0]	AAAA	XXAA	XXAA	XXXA	XXXA	XXXA	XXXA
Bit Number XD	31 0 ABCD	15 0 CD	15 0 AB	7 0 D	7 0 C	7 0 B	7 0 A
Bit Number Ext. Mem Data	31 0 ABCD	15 0 CD	15 0 AB	7 0 D	7 0 C	7 0 B	7 0 A
Timing Sequence		1st write	2nd write	1st write	2nd write	3rd write	4th write

Table6.2.10 Word access read operation with little endian

ACCESS OPERATION	READ OPERATION (CPU REGISTER ← EXTERNAL MEMORY)						
	WORD	HALF WORD		BYTE			
Bit Number CPU Reg Data	31 0 ABCD	31 0 ABCD		31 0 ABCD			
SA	WA	WA		WA			
Bit Number SD	31 0 ABCD	31 0 AB CD		31 0 A B C D			
Bit Number ED	31 0 ABCD	31 0 XX CD	31 0 AB CD	31 0 X X X D	31 0 X X C D	31 0 X B C D	31 0 A B C D
XA	WA	WA	WA+2	WA	WA+1	WA+2	WA+3
SDQM [3-0]	AAAA	XXAA	XXAA	XXXA	XXXA	XXXA	XXXA
Bit Number XD	31 0 ABCD	15 0 CD	15 0 AB	7 0 D	7 0 C	7 0 B	7 0 A
Bit Number Ext. Mem Data	31 0 ABCD	15 0 CD	15 0 AB	7 0 D	7 0 C	7 0 B	7 0 A
Timing Sequence		1st read	2nd read	1st read	2nd read	3rd read	4th read

W90P710CD/W90P710CDG



Table 6.2.11 and Table 6.2.12

Using little-endian and half-word access, Program/Data path between register and external memory.

HA = Address whose LSB is 0,2,4,6,8,A,C,E HAL = Address whose LSB is 0,4,8,C

HAU = Address whose LSB is 2,6,A,E X = Don't care

nWBE [3-0] / SDQM [3-0] = A means active and U means inactive

Table6.2.11 Half-word access write operation with little-endian

ACCESS OPERATION	WRITE OPERATION (CPU REGISTER → EXTERNAL MEMORY)				
	WORD		HALF WORD	BYTE	
Bit Number CPU Reg Data	31 0 ABCD		31 0 ABCD	31 0 ABCD	
SA	HAL	HAU	HA	HA	
Bit Number SD	31 0 CD CD	31 0 CD CD	31 0 CD CD	31 0 CD CD	31 0 CD CD
Bit Number ED	31 0 CD CD	31 0 CD CD	31 0 CD CD	7 0 D	7 0 C
XA	HAL	HAL	HA	HA	HA+1
nWBE [3-0] / SDQM [3-0]	UUAA	AAUU	XXAA	XXXA	XXXA
Bit Number XD	31 0 CD CD	31 0 CD CD	15 0 CD	7 0 D	7 0 C
Bit Number Ext. Mem Data	15 0 CD	31 16 CD	15 0 CD	7 0 D	7 0 C
Timing Sequence				1st write	2nd write

Table6.2.12 Half-word access read operation with Little-endian

ACCESS OPERATION	READ OPERATION (CPU REGISTER ← EXTERNAL MEMORY)				
	WORD		HALF WORD	BYTE	
Bit Number CPU Reg Data	15 0 CD	15 0 AB	15 0 CD	15 0 CD	
SA	HAL	HAU	HA	HA	
Bit Number SD	15 0 CD	15 0 AB	15 0 CD	15 0 CD	
Bit Number ED	15 0 CD	15 0 AB	15 0 CD	15 0 XD	15 0 CD
XA	HAL	HAL	HA	HA	HA+1
SDQM [3-0]	UUAA	AAUU	XXAA	XXXA	XXXA
Bit Number XD	31 0 AB CD	31 0 AB CD	15 0 CD	7 0 D	7 0 C
Bit Number Ext. Mem Data	31 0 ABCD		15 0 CD	7 0 D	7 0 C
Timing Sequence				1st read	2nd read

W90P710CD/W90P710CDG



Table 6.2.13 and Table 6.2.14

Using little-endian and byte access, Program/Data path between register and external memory.

BA = Address whose LSB is 0,1,2,3,4,5,6,7,8,9,A,B,C,D,E,F

BAL = Address whose LSB is 0,2,4,6,8,A,C,E BAU = Address whose LSB is 1,3,5,7,9,B,D,F

BA0 = Address whose LSB is 0,4,8,C BA1 = Address whose LSB is 1,5,9,D

BA2 = Address whose LSB is 2,6,A,E BA3 = Address whose LSB is 3,7,B,F

Table6.2.13 Byte access write operation with little-endian

ACCESS OPERATION	WRITE OPERATION (CPU REGISTER → EXTERNAL MEMORY)						
XD WIDTH	WORD				HALF WORD		BYTE
Bit Number CPU Reg Data	31 0 ABCD				31 0 ABCD		31 0 ABCD
SA	BA0	BA1	BA2	BA3	BAL	BAU	BA
Bit Number SD	31 0 D D D D	31 0 D D D D	31 0 D D D D	31 0 D D D D	31 0 D D D D	31 0 D D D D	31 0 D D D D
Bit Number ED	7 0 D	15 8 D	23 16 D	31 24 D	7 0 D	15 8 D	7 0 D
XA	BA0	BA0	BA0	BA0	BAL	BAL	BA
nWBE [3-0] / SDQM [3-0]	UUUA	UUAU	UAUU	AUUU	XXUA	XXAU	XXXXA
Bit Number XD	31 0 X X X D	31 0 X X D X	31 0 X D X X	31 0 D X X X	15 0 X D	15 0 D X	7 0 D
Bit Number Ext. Mem Data	7 0 D	15 8 D	23 16 D	31 24 D	7 0 D	15 8 D	7 0 D
Timing Sequence							

Table6.2.14 Byte access read operation with Little-endian

ACCESS OPERATION	READ OPERATION (CPU REGISTER ← EXTERNAL MEMORY)						
XD WIDTH	WORD				HALF WORD		BYTE
Bit Number CPU Reg Data	7 0 D	7 0 C	7 0 B	7 0 A	7 0 D	7 0 C	7 0 D
SA	BA0	BA1	BA2	BA3	BAL	BAU	BA
Bit Number SD	7 0 D	7 0 C	7 0 B	7 0 A	7 0 D	7 0 C	7 0 D
Bit Number ED	7 0 D	7 0 C	7 0 B	7 0 A	7 0 D	7 0 C	7 0 D
XA	BA0	BA0	BA0	BA0	BAL	BAL	BA
SDQM [3-0]	UUUA	UUAU	UAUU	AUUU	XXUA	XXAU	XXXXA
Bit Number XD	31 0 ABCD	31 0 ABCD	31 0 ABCD	31 0 ABCD	15 0 CD	15 0 CD	7 0 D
Bit Number Ext. Mem Data	31 0 ABCD				15 0 CD		7 0 D
Timing Sequence							



6.2.5 Bus Arbitration

The W90P710's internal function blocks or external devices can request mastership of the system bus and then hold the system bus in order to perform data transfers. Because the design of W90P710 bus allows only one bus master at a time, a bus controller is required to arbitrate when two or more internal units or external devices simultaneously request bus mastership. When bus mastership is granted to an internal function block or an external device, other pending requests are not acknowledged until the previous bus master has released the bus.

W90P710 supports two priority modes, the **Fixed Priority Mode** and the **Rotate Priority Mode**, depends on the ARBCON register **PRTMOD** bit setting.

6.2.5.1 Fixed Priority Mode

In **Fixed Priority Mode** (**PRTMOD**=0, default value), to facilitate bus arbitration, priorities are assigned to each internal W90P710 function block. The bus controller arbitration requests for the bus mastership according to these fixed priorities. In the event of contention, mastership is granted to the function block with the highest assigned priority. These priorities are listed in Table 6.2.15.

W90P710 allows raising ARM Core priority to second if an unmasked interrupt occurs. If **IPEN** bit, Bit 1 of the **Arbitration Control Register (ARBCON)**, is set to "0", the priority of ARM Core is fixed at lowest. If **IPEN** bit is set to "1" and if no unmasked interrupt request, then the ARM Core's priority is still lowest and the **IPACT**=0, Bit 2 of the **Arbitration Control Register (ARBCON)**. If there is an unmasked interrupt request, then the ARM Core's priority is raised to first and **IPACT**=1.

If **IPEN** is set, an interrupt handler will normally clear **IPACT** at the end of the interrupt routine to allow an alternate bus master to regain the bus. However, if **IPEN** is cleared, no additional action need be taken in the interrupt handler. The **IPACT** bit can be read and write. Writing with "0", the **IPACT** bit is cleared, however writing with "1" has no effect.

Table 6.2.15 Bus Priorities for Arbitration in Fixed Priority Mode

BUS PRIORITY	FUNCTION BLOCK	
	IPACT = 0	IPEN = 1 AND IPACT = 1
1 (Highest)	Audio Controller (AC97 & I2S)	ARM Core
2	LCD	Audio Controller (AC97 & I2S)
3	General DMA0	LCD Controller
4	General DMA1	General DMA0
5	EMC DMA	General DMA1
6	SD	EMC DMA
7	USB Host	SD
8	USB Device	USB Host
9(Lowest)	ARM Core	USB Device



6.2.5.2 Rotate Priority Mode

In **Rotate Priority Mode** (**PRTMOD=1**), the **IPEN** and **IPACT** bits have no function (i.e. can be ignored). W90P710 uses a round robin arbitration scheme to ensure that all bus masters have equal chance to gain the bus and that a retracted master does not lock up the bus.

6.2.6 Power management

W90P710 provides three power management scenarios to reduce power consumption. The peripherals' clocks can be enabled / disabled individually by controlling the corresponding bit in **CLKSEL** control register. Software can turn-off unused modules' clocks to prevent unnecessary power consumption. It also provides **idle** and **power-down** modes to reduce power consumption.

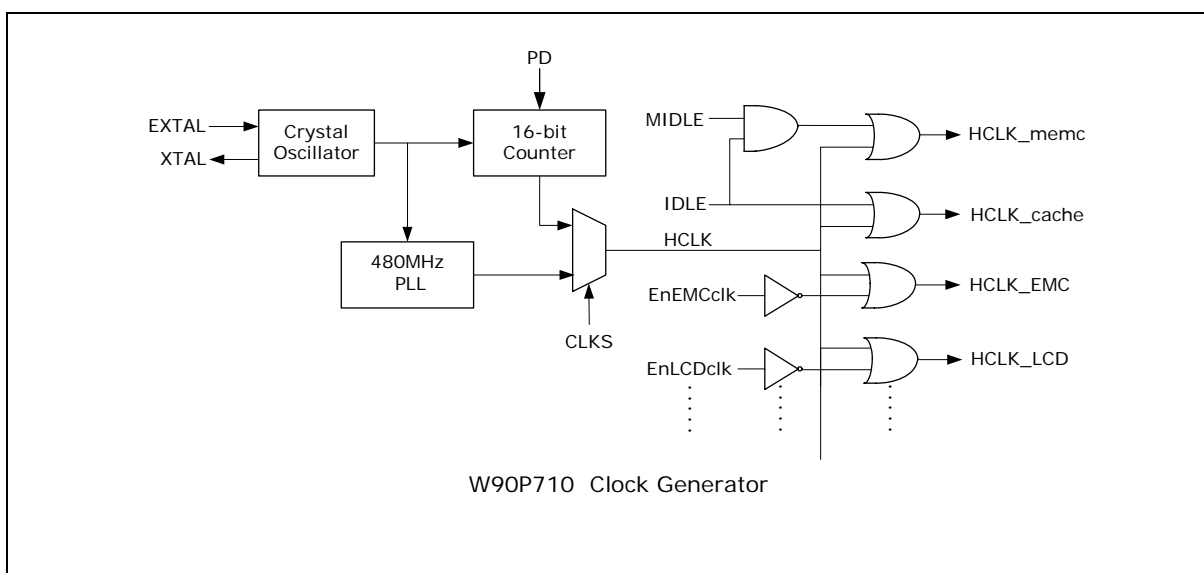

Fig. 6.2.6 W90P710 system clock generation diagram

IDLE MODE

If the **IDLE** bit in Power Management Control Register (PMCON) is set, the ARM CORE clock source is halted and the ARM CORE will not go forward. The AHB or APB clocks are still active except for the clock to cache controller and ARM, which are stopped. W90P710 will exit idle state when nIRQ or nFIQ from any peripheral is revived; like keypad, timer-overflow interrupts and so on. The memory controller can also be forced to enter idle state if both **MIDDLE** and **IDLE** bits are set. Software must switch SDRAM into self-refresh mode before forcing memory to enter idle mode.

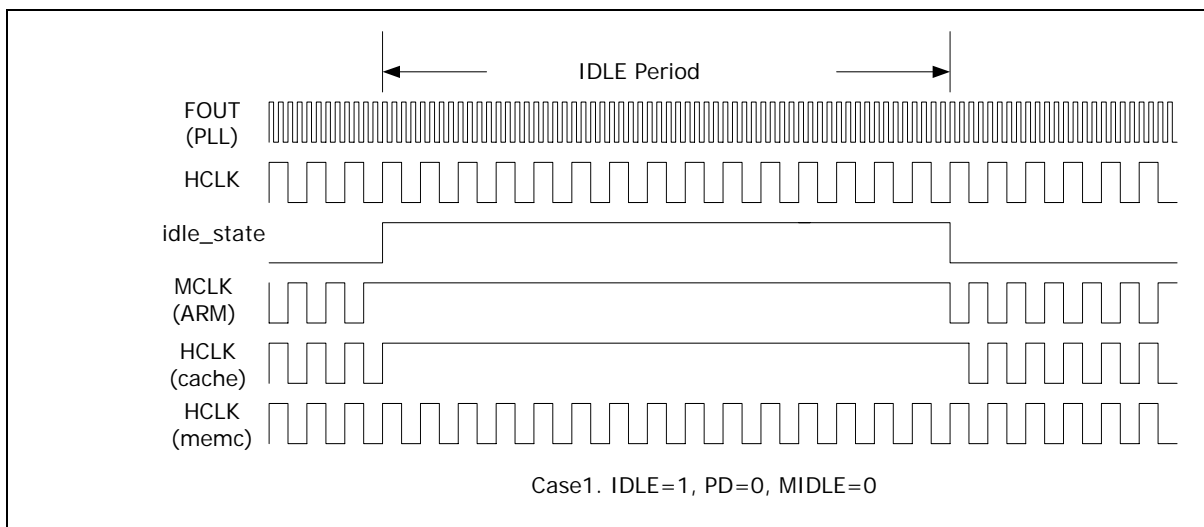

Fig. 6.2.7 Clock management for system idle mode

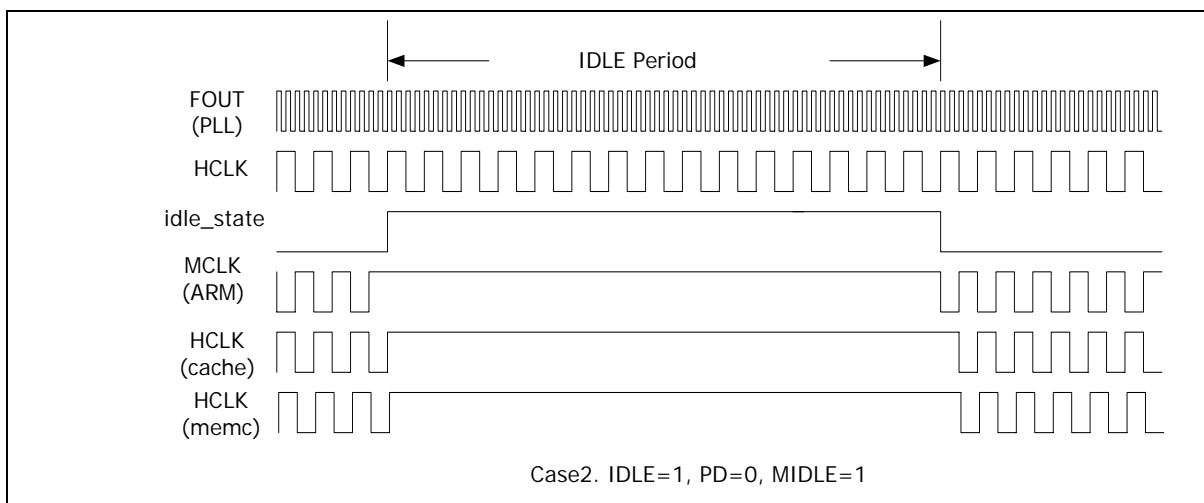

Fig. 6.2.8 Clock management for system and memory idle mode

Power Down Mode

This mode provides the minimum power consumption. When the W90P710 system is not working or waiting for an external event, software can set the PD bit to “1” to turn off all the clocks, including system crystal oscillator to let ARM CORE enter sleep mode. In this state, all peripherals are also in sleep mode since the clock source is stopped. W90P710 will exit power down state when nIRQ/nFIQ is detected. W90P710 provides external interrupt nIRQ[3:0], keypad, and USB device interface to wakeup the system clock.

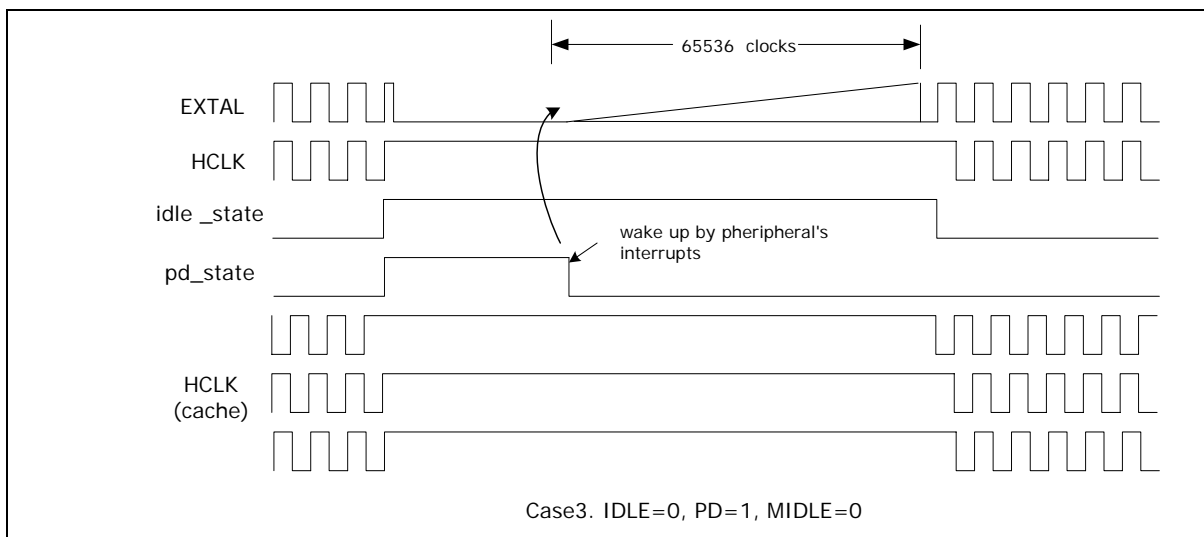

Fig 6.2.9 Clock management for system power down mode and wake up

6.2.7 Power-On Setting

After power on reset, there are eight Power-On setting pins to configure W90P710 system configuration.

POWER-ON SETTING	PIN
Internal System Clock Select	D15
Little/Big-endian Mode Select	D14
Boot ROM/FLASH Data Bus Width	D [13:12]
Default (Always pulled up during normal operation)	D [11:8]

D15 pin: Internal System Clock Select

If pin D15 is pull-down, the external clock from EXTAL pin serves as an internal system clock.

If pin D15 is pull-up, the PLL output clock is used as internal system clock.

D14 pin: Little/Big-endian Mode Select

If pin D14 is pull-down, the external memory format is Big-endian mode.

If pin D14 is pull-up, the external memory format is Little-endian mode.

D [13:12] : Boot ROM/FLASH Data Bus Width

D [13:12]		BUS WIDTH
Pull-down	Pull-down	8-bit
Pull-down	Pull-up	16-bit
Pull-up	Pull-down	32-bit
Pull-up	Pull-up	RESERVED

W90P710CD/W90P710CDG



6.2.8 System Manager Control Registers Map

REGISTER	ADDRESS	R/W	DESCRIPTION	RESET VALUE
PDID	0xFFFF0_0000	R	Product Identifier Register	0xX090_0710
ARBCON	0xFFFF0_0004	R/W	Arbitration Control Register	0x0000_0000
PLLCON0	0xFFFF0_0008	R/W	PLL Control Register 0	0x0000_2F01
CLKSEL	0xFFFF0_000C	R/W	Clock Select Register	0x1FFF_3FX8
PLLCON1	0xFFFF0_0010	R/W	PLL Control Register 1	0x0001_0000
I2SCKCON	0xFFFF0_0014	R/W	Audio IIS Clock Control Register	0x0000_0000
IRQWAKECON	0xFFFF0_0020	R/W	IRQ Wakeup Control register	0x0000_0000
IRQWAKEFLAG	0xFFFF_0024	R/W	IRQ wakeup Flag Register	0x0000_0000
PMCON	0xFFFF0_0028	R/W	Power Manager Control Register	0x0000_0000
USBTxrCON	0xFFFF0_0030	R/W	USB Transceiver Control Register	0x0000_0000

Product Identifier Register (PDID)

This register is read only and provides information on certain characteristics of the chip ID and the version number.

REGISTER	ADDRESS	R/W	DESCRIPTION	RESET VALUE
PDID	0xFFFF0_0000	R	Product Identifier Register	0xX090_0710

31	30	29	28	27	26	25	24
PACKAGE		VERSION					
23	22	21	20	19	18	17	16
CHPID							
15	14	13	12	11	10	9	8
CHPID							
7	6	5	4	3	2	1	0
CHPID							

W90P710CD/W90P710CDG



BITS		DESCRIPTION							
[31:30]	PACKAGE	Package Type Select These two bits are power-on setting latched from pin D[9:8] <table border="1" style="margin-left: 20px;"> <thead> <tr> <th colspan="2">Package [31:30]</th> <th>Package Type</th> </tr> </thead> <tbody> <tr> <td>1</td> <td>1</td> <td>176-pin Package</td> </tr> </tbody> </table>		Package [31:30]		Package Type	1	1	176-pin Package
Package [31:30]		Package Type							
1	1	176-pin Package							
[29:24]	VERSION	Version of chip							
[23:0]	CHIPID	The chip identifier 0x090.0710							

Arbitration Control Register (ARBCON)

REGISTER	ADDRESS	R/W	DESCRIPTION	RESET VALUE
ARBCON	0xFFF0_0004	R/W	Arbitration Control Register	0x0000_0000

31	30	29	28	27	26	25	24
RESERVED							
23	22	21	20	19	18	17	16
RESERVED							
15	14	13	12	11	10	9	8
RESERVED							
7	6	5	4	3	2	1	0
RESERVED					IPACT	IPEN	PRTMOD

BITS		DESCRIPTION	
[31:3]	RESERVED	-	
[2]	IPACT	Interrupt priority active. When IPEN="1" , this bit will be set when the ARM core has an unmasked interrupt request. This bit is available only when the PRTMOD=0 .	
[1]	IPEN	Interrupt priority enable bit 0 = the ARM core has the lowest priority. 1 = enable to raise the ARM core priority to second This bit is available only when the PRTMOD=0 .	
[0]	PRTMOD	Priority mode select 0 = Fixed Priority Mode (default) 1 = Rotate Priority Mode	

W90P710CD/W90P710CDG



PLL Control Register0 (PLLCON0)

W90P710 provides two clock signal generating options – crystal and oscillator. The external clock via **EXTAL(15M)** input pin as the reference clock input of the **PLL** module. The external clock can bypass the **PLL** and be used for the internal system clock by pulling down data pin D15. Using **PLL**'s output clock for the internal system clock, D15 must be pulled up.

REGISTER	ADDRESS	R/W	DESCRIPTION	RESET VALUE
PLLCON	0xFFFF0_0008	R/W	PLL Control Register	0x0000_2F01

31	30	29	28	27	26	25	24
RESERVED							
23	22	21	20	19	18	17	16
RESERVED							PVDEN
15	14	13	12	11	10	9	8
FBDV							
7	6	5	4	3	2	1	0
FBDV	OTDV		INDV				

BITS	DESCRIPTION																
[31:17]	RESERVED	-															
[16]	PVDEN	Power down mode enable 0 = PLL is in normal mode (default) 1 = PLL is in power down mode															
[15:7]	FBDV	PLL VCO output clock feedback divider Feedback Divider divides the output clock from VCO of PLL.															
[6:5]	OTDV	PLL output clock divider <table border="1" style="margin-left: 20px;"> <thead> <tr> <th colspan="2">OTDV [6:5]</th> <th>DIVIDED BY</th> </tr> </thead> <tbody> <tr> <td>0</td> <td>0</td> <td>1</td> </tr> <tr> <td>0</td> <td>1</td> <td>2</td> </tr> <tr> <td>1</td> <td>0</td> <td>2</td> </tr> <tr> <td>1</td> <td>1</td> <td>4</td> </tr> </tbody> </table>	OTDV [6:5]		DIVIDED BY	0	0	1	0	1	2	1	0	2	1	1	4
OTDV [6:5]		DIVIDED BY															
0	0	1															
0	1	2															
1	0	2															
1	1	4															
[4:0]	INDV	PLL input clock divider Input divider divides the input reference clock into the PLL.															

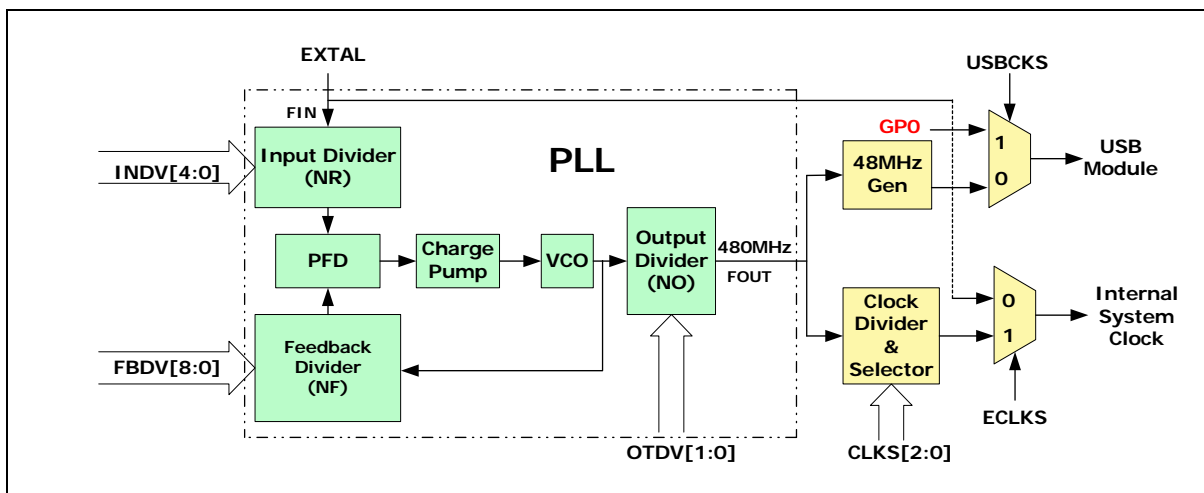

Fig 6.2.8.1 System PLL block diagram

PLL output clock formula:

$$F_{OUT} = F_{IN} * \frac{NF}{NR} * \frac{1}{NO}$$

F_{OUT}:Output clock of **Output Divider**

F_{IN}:External clock into the **Input Divider**

NR:Input divider value (NR = INDV + 2)

NF:Feedback divider value (NF = FBDV + 2)

NO:Output divider value (NO = OTDV)

Clock Select Register (CLKSEL)

REGISTER	ADDRESS	R/W	DESCRIPTION	RESET VALUE
CLKSEL	0xFFFF0_000C	R/W	Clock Select Register	0x1FFF_7FX8

31	30	29	28	27	26	25	24
RESERVED			PS2	KPI	SCH1	SCH0	SSP
23	22	21	20	19	18	17	16
UART3	UART2	UART1	I2C1	I2C0	RTC	PWM	AC97
15	14	13	12	11	10	9	8
USBCKS	USB	GDMA	SD	LCD	EMC	RESERVED	WDT
7	6	5	4	3	2	1	0
USBH	TIMER	UART	ECLKS	CLKS			RESET

W90P710CD/W90P710CDG



BITS	DESCRIPTION	
[31:29]	RESERVED	-
[28]	PS2	PS2 controller clock enable bit 0 = Disable PS2 controller clock 1 = Enable PS2 controller clock
[27]	KPI	Keypad controller clock enable bit 0 = Disable keypad controller clock 1 = Enable keypad controller clock
[26]	SCH1	Smart Card Host controller 1 clock enable bit 0 = Disable smart card host controller 1 clock 1 = Enable smart card host controller 1 clock
[25]	SCH0	Smart Card Host controller 0 clock enable bit 0 = Disable smart card host controller 0 clock 1 = Enable smart card host controller 0 clock
[24]	USI	USI controller clock enable bit 0 = Disable USI controller clock 1 = Enable USI controller clock
[23]	UART3	UART3 controller clock enable bit 0 = Disable UART3 controller clock 1 = Enable UART3 controller clock
[22]	UART2	UART2 controller clock enable bit 0 = Disable UART2 controller clock 1 = Enable UART2 controller clock
[21]	UART1	UART1 controller clock enable bit 0 = Disable UART1 controller clock 1 = Enable UART1 controller clock
[20]	I2C1	I2C1 controller clock enable bit 0 = Disable I2C1 controller clock 1 = Enable I2C1 controller clock
[19]	I2C0	I2C0 controller clock enable bit 0 = Disable I2C0 controller clock 1 = Enable I2C0 controller clock
[18]	RTC	RTC unit clock enable bit 0 = Disable RTC controller clock 1 = Enable RTC controller clock

W90P710CD/W90P710CDG



Continued.

BITS	DESCRIPTION	
[17]	PWM	PWM controller clock enable bit 0 = Disable PWM controller clock 1 = Enable PWM controller clock
[16]	AC97	Audio Controller clock enable bit 0 = Disable AC97 controller clock 1 = Enable AC97 controller clock
[15]	USBCKS	USB host/device 48MHz clock source Select bit 0 = USB clock 48MHz input from internal PLL (480MHz/10) 1 = USB clock 48MHz input from external GPIO0 pin. Pin direction must be set to input.
[14]	USB D	USB device clock enable bit 0 = Disable USB device controller clock 1 = Enable USB device controller clock
[13]	GDMA	GDMA controller clock enable bit 0 = Disable GDMA clock 1 = Enable GDMA clock
[12]	SD	SD host controller clock enable bit 0 = Disable SD controller clock 1 = Enable SD controller clock
[11]	LCD	LCD controller clock enable bit 0 = Disable LCD controller clock 1 = Enable LCD controller clock
[10]	EMC	EMC controller clock enable bit 0 = Disable EMC controller clock 1 = Enable EMC controller clock
[9]	RESERVED	-
[8]	WDT	WDT clock enable bit 0 = Disable WDT counting clock 1 = Enable WDT counting clock
[7]	USBH	USB host clock enable bit 0 = Disable USB host controller clock 1 = Enable USB host controller clock
[6]	TIMER	Timer clock enable bit 0 = Disable timer clock 1 = Enable timer clock

W90P710CD/W90P710CDG



Continued.

BITS	DESCRIPTION																																					
[5]	UART0	UART0 controller clock enable bit 0 = Disable UART0 controller clock 1 = Enable UART0 controller clock																																				
[4]	ECLKS	External clock select 0 = External clock from EXTAL pin is used as system clock 1 = PLL output clock is used as system clock After power on reset, the content of ECLKS is the Power-On Setting value. You can program this bit to change the system clock source.																																				
[3:1]	CLKS	PLL output clock select <table border="1" data-bbox="646 751 1308 1129"> <thead> <tr> <th colspan="3" data-bbox="646 751 932 793">CLKS [3:1]</th> <th data-bbox="932 751 1308 793">System clock</th> </tr> </thead> <tbody> <tr> <td data-bbox="646 793 743 835">0</td> <td data-bbox="743 793 841 835">0</td> <td data-bbox="841 793 932 835">0</td> <td data-bbox="932 793 1308 835">58.594 KHz*</td> </tr> <tr> <td data-bbox="646 835 743 877">0</td> <td data-bbox="743 835 841 877">0</td> <td data-bbox="841 835 932 877">1</td> <td data-bbox="932 835 1308 877">24 MHz</td> </tr> <tr> <td data-bbox="646 877 743 919">0</td> <td data-bbox="743 877 841 919">1</td> <td data-bbox="841 877 932 919">0</td> <td data-bbox="932 877 1308 919">48 MHz</td> </tr> <tr> <td data-bbox="646 919 743 961">0</td> <td data-bbox="743 919 841 961">1</td> <td data-bbox="841 919 932 961">1</td> <td data-bbox="932 919 1308 961">60 MHz</td> </tr> <tr> <td data-bbox="646 961 743 1003">1</td> <td data-bbox="743 961 841 1003">0</td> <td data-bbox="841 961 932 1003">0</td> <td data-bbox="932 961 1308 1003">80 MHz</td> </tr> <tr> <td data-bbox="646 1003 743 1045">1</td> <td data-bbox="743 1003 841 1045">0</td> <td data-bbox="841 1003 932 1045">1</td> <td data-bbox="932 1003 1308 1045">RESERVED</td> </tr> <tr> <td data-bbox="646 1045 743 1087">1</td> <td data-bbox="743 1045 841 1087">1</td> <td data-bbox="841 1045 932 1087">0</td> <td data-bbox="932 1045 1308 1087">RESERVED</td> </tr> <tr> <td data-bbox="646 1087 743 1129">1</td> <td data-bbox="743 1087 841 1129">1</td> <td data-bbox="841 1087 932 1129">1</td> <td data-bbox="932 1087 1308 1129">RESERVED</td> </tr> </tbody> </table> <p data-bbox="573 1140 1401 1318"> Note: 1. These values are based on PLL output(FOUT) is 480MHz. 2. When 24Mhz ~ 80MHz is selected, the ECLKS bit must be set to 1. 3. About 58.594KHz setting, two steps are needed. First, clear ECLKS bit, and then clear CLKS. </p>	CLKS [3:1]			System clock	0	0	0	58.594 KHz*	0	0	1	24 MHz	0	1	0	48 MHz	0	1	1	60 MHz	1	0	0	80 MHz	1	0	1	RESERVED	1	1	0	RESERVED	1	1	1	RESERVED
CLKS [3:1]			System clock																																			
0	0	0	58.594 KHz*																																			
0	0	1	24 MHz																																			
0	1	0	48 MHz																																			
0	1	1	60 MHz																																			
1	0	0	80 MHz																																			
1	0	1	RESERVED																																			
1	1	0	RESERVED																																			
1	1	1	RESERVED																																			
[0]	RESET	Software reset bit Set the software reset control bit to 1 to generate an internal reset pulse. This bit automatically clears to logic 0 after the reset pulse.																																				

W90P710CD/W90P710CDG



PLL Control Register 1 (PLLCON1)

W90P710 provides extra a PLL for the LCD controller programmable pixel clock and provides 12.288/16.934 MHz clock source to Audio Controller. It uses the same 15MHz crystal clock input source with the system PLL mentioned above.

REGISTER	ADDRESS	R/W	DESCRIPTION	RESET VALUE
PLLCON1	0xFFFF0_0010	R/W	PLL Control Register 1	0x0001_0000

31	30	29	28	27	26	25	24
RESERVED							
23	22	21	20	19	18	17	16
RESERVED							PWDEN1
15	14	13	12	11	10	9	8
FBDV1							
7	6	5	4	3	2	1	0
FBDV1	OTDV1		INDV1				

BITS	DESCRIPTION																
[31:17]	RESERVED	-															
[16]	PWDEN1	PLL1 power down enable 0 = PLL1 is in normal mode 1 = PLL1 is in power down mode (default)															
[15:7]	FBDV1	PLL1 VCO output clock feedback divider Feedback Divider divides the output clock from VCO of PLL1.															
[6:5]	OTDV1	PLL1 output clock divider <table border="1" style="margin-left: 20px;"> <thead> <tr> <th colspan="2">OTDV1 [6:5]</th> <th>Divided by</th> </tr> </thead> <tbody> <tr> <td>0</td> <td>0</td> <td>1</td> </tr> <tr> <td>0</td> <td>1</td> <td>2</td> </tr> <tr> <td>1</td> <td>0</td> <td>2</td> </tr> <tr> <td>1</td> <td>1</td> <td>4</td> </tr> </tbody> </table>	OTDV1 [6:5]		Divided by	0	0	1	0	1	2	1	0	2	1	1	4
OTDV1 [6:5]		Divided by															
0	0	1															
0	1	2															
1	0	2															
1	1	4															
[4:0]	INDV1	PLL1 input clock divider Input divider divides the input reference clock into the PLL1.															

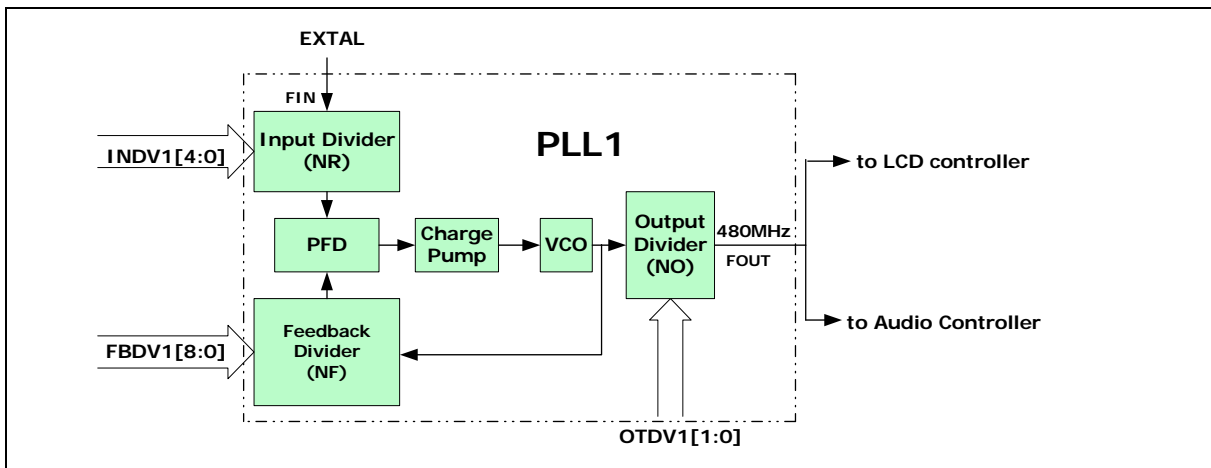

Fig 6.2.8.2 LCD PLL block diagram

PLL output clock formula is:

$$F_{OUT} = F_{IN} * \frac{NF}{NR} * \frac{1}{NO}$$

F_{OUT}: Output clock of **Output Divider**

F_{IN}: External clock into the **Input Divider**

NR: Input divider value (NR = INDV1 + 2)

NF: Feedback divider value (NF = FBDV1 + 2)

NO: Output divider value (NO = OTDV1)

W90P710CD/W90P710CDG



IIS Clock Control Register (I2SCKCON)

REGISTER	ADDRESS	R/W	DESCRIPTION	RESET VALUE
I2SCKCON	0xFFFF0_0014	R/W	I2S PLL clock Control Register	0x0000_0000

31	30	29	28	27	26	25	24
RESERVED							
23	22	21	20	19	18	17	16
RESERVED							
15	14	13	12	11	10	9	8
RESERVED							IISPLLEN
7	6	5	4	3	2	1	0
PRESCALE							

BITS	DESCRIPTION	
[31:9]	RESERVED	-
[8]	IISPLLEN	<p>IIS PLL clock source enable</p> <p>Set this bit to enable PLL1 clock output to audio I2S clock input.</p> <p>1 = Enable PLL1 clock source for audio I2S</p> <p>0 = Disable PLL1 clock source for audio I2S</p>
[7:0]	PRESCALE	<p>The PLL1 is shared with the LCD controller. If both the LCD and I2S are using the PLL1 at the same time, software can use the prescaler to generate an appropriate clock around 12.288M or 16.934M. The clock is generated as below, and if PRESCALE =0, the PLL_AUDIO is the same frequency as FOUT “PLL_AUDIO = PLL_FOUT/(PRESCALE +1)”</p>

IRQ Wakeup Control Register (IRQWAKECON)

REGISTER	ADDRESS	R/W	DESCRIPTION	RESET VALUE
IRQWAKECON	0xFFFF0_0020	R/W	IRQ Wakeup Control Register	0x0000_0000

31	30	29	28	27	26	25	24
RESERVED							
23	22	21	20	19	18	17	16
RESERVED							
15	14	13	12	11	10	9	8
RESERVED							
7	6	5	4	3	2	1	0
IRQWAKEUPPOL				IRQWAKEUPEN			



BITS	DESCRIPTION	
[31:8]	RESERVED	
[7]	IRQWAKEUPPOL[3]	nIRQ3 wake up polarity 1 = nIRQ3 is high level wake up 0 = nIRQ3 is low level wake up
[6]	IRQWAKEUPPOL[2]	nIRQ2 wake up polarity 1 = nIRQ2 is high level wake up 0 = nIRQ2 is low level wake up
[5]	IRQWAKEUPPOL[1]	nIRQ1 wake up polarity 1 = nIRQ1 is high level wake up 0 = nIRQ1 is low level wake up
[4]	IRQWAKEUPPOL[0]	nIRQ0 wake up polarity 1 = nIRQ0 is high level wake up 0 = nIRQ0 is low level wake up
[3]	IRQWAKEUPEN[3]	nIRQ3 wake up enable bit 1 = nIRQ3 wake up enable 0 = nIRQ3 wake up disable
[2]	IRQWAKEUPEN[2]	nIRQ2 wake up enable bit 1 = nIRQ2 wake up enable 0 = nIRQ2 wake up disable
[1]	IRQWAKEUPEN[1]	nIRQ1 wake up enable bit 1 = nIRQ1 wake up enable 0 = nIRQ1 wake up disable
[0]	IRQWAKEUPEN[0]	nIRQ0 wake up enable bit 1 = nIRQ0 wake up enable 0 = nIRQ0 wake up disable

IRQ Wakeup Flag Register (IRQWAKEFLAG)

REGISTER	ADDRESS	R/W	DESCRIPTION	RESET VALUE
IRQWAKEFLAG	0xFFFF0_0024	R/W	IRQ Wakeup Flag Register	0x0000_0000

W90P710CD/W90P710CDG



31	30	29	28	27	26	25	24
RESERVED							
23	22	21	20	19	18	17	16
RESERVED							
15	14	13	12	11	10	9	8
RESERVED							
7	6	5	4	3	2	1	0
RESERVED				IRQWAKEFLAG			

This register is used to record the wakeup events, after clock recovery, software should check these flags to identify which nIRQ is used to wakeup the system. And clear the flags in an IRQ interrupt service routine.

BITS	DESCRIPTION	
[31:4]	RESERVED	-
[3]	IRQWAKEFLAG[3]	nIRQ3 wake up flag 1 = Chip is woken up by nIRQ3 0 = No active
[2]	IRQWAKEFLAG[2]	nIRQ2 wake up flag 1 = Chip is woken up by nIRQ2 0 = No active
[1]	IRQWAKEFLAG[1]	nIRQ1 wake up flag 1 = Chip is woken up by nIRQ1 0 = No active
[0]	IRQWAKEFLAG[0]	nIRQ0 wake up flag 1 = Chip is woken up by nIRQ0 0 = No active

Power Management Control Register (PMCON)

REGISTER	ADDRESS	R/W	DESCRIPTION	RESET VALUE
PMCON	0xFFF0_0028	R/W	Power Management Control Register	0x0000_0000

31	30	29	28	27	26	25	24
RESERVED							
23	22	21	20	19	18	17	16
RESERVED							
15	14	13	12	11	10	9	8
RESERVED							
7	6	5	4	3	2	1	0
RESERVED					MIDLE	PD	IDLE

W90P710CD/W90P710CDG



BITS		DESCRIPTION
[31:3]	RESERVED	
[2]	MIDDLE	<p>Memory controller IDLE enable</p> <p>Setting both MIDDLE and IDLE bits HIGH allows the memory controller to enter IDLE mode. The memory controller clock source halts when ARM CORE enters IDLE.</p> <p>1=memory controller is forced into IDLE mode, (memory controller clock halts), when IDLE bit is set.</p> <p>0 = memory controller still active when IDLE bit is set.</p> <p>NOTE: Software must let SDRAM enter self-refresh mode to enable this function because SDRAM MCLK is stopped.</p>
[1]	PD	<p>Power down enable</p> <p>Setting this bit HIGH allows W90P710 to enter power saving mode. The 15M-crystal oscillator clock source and PLLs are stopped. User can use nIRQ[3:0], keypad and external RESET to wakeup W90P710.</p> <p>1 = Enable power down</p> <p>0 = Disable</p>
[0]	IDLE	<p>IDLE mode enable</p> <p>Setting this bit HIGH allows ARM Core to enter power saving mode. The peripherals can still keep working if the clock enable bit in CLKSEL is set. Any nIRQ or nFIQ to ARM Core allows ARM CORE to exit IDLE state.</p> <p>1 = IDLE mode</p> <p>0 = Disable</p>

USB Transceiver Control Register (USBTXRCON)

REGISTER	ADDRESS	R/W	DESCRIPTION	RESET VALUE
USBTXRCON	0xFFFF0_0030	R/W	USB Transceiver Control Register	0x0000_0000

31	30	29	28	27	26	25	24
RESERVED							
23	22	21	20	19	18	17	16
RESERVED							
15	14	13	12	11	10	9	8
RESERVED							
7	6	5	4	3	2	1	0
RESERVED							USBHnD



BITS	DESCRIPTION	
[31:1]	RESERVED	-
[0]	USBHnD	<p>USBHnD[0]: USB transceiver control</p> <p>There are two USB1.1 built-in transceivers. One is a dedicated USB host, and the other is shared with USB device. This bit can be set in software to toggle the transceiver path.</p> <p>1 = HOST 0 = Device</p>

6.3 External Bus Interface

6.3.1 EBI Overview

W90P710 supports External Bus Interface (**EBI**), which controls access to external memory (ROM/FLASH, SDRAM) and External I/O devices. The **EBI** has seven chip selects to select one ROM/FLASH bank, two SDRAM banks, and four External I/O banks. The address bus is 22-bits. It supports an 8-bit, 16-bit, and 32-bit external data bus width for each bank.

The EBI has the following functions:

- SDRAM controller
- EBI control register
- ROM/FLASH interface
- External I/O interface
- External bus mastership

6.3.2 SDRAM Controller

The SDRAM controller module within W90P710 contains configuration registers, timing control registers, the common control register, and other logic to provide an 8, 16, and 32-bit SDRAM interface with a single 8, 16, 32-bit SDRAM device or two 8-bit devices wired to provide a 16-bit data path or two 16-bit devices wired to give a 32-bit data path. The maximum size of each bank is 64M bytes, and maximum memory size can span up to 128MB.

The SDRAM controller has the following features:

- Supports up to 2 external SDRAM banks
- Maximum size of each bank is 64M bytes
- 8, 16, 32-bit data interface
- Programmable CAS Latency: 1, 2 and 3
- Fixed Burst Length: 1
- Sequential burst type
- Auto Refresh Mode and Self Refresh Mode
- Adjustable Refresh Rate
- Power up sequence

W90P710CD/W90P710CDG



6.3.2.1 SDRAM Components Supported

Table 6.3.2.1 SDRAM supported by W90P710

SIZE	TYPE	BANKS	ROW ADDRESSING	COLUMN ADDRESSING
16M bits	2Mx8	2	RA0~RA10	CA0~CA8
	1Mx16	2	RA0~RA10	CA0~CA7
64M bits	8Mx8	4	RA0~RA11	CA0~CA8
	4Mx16	4	RA0~RA11	CA0~CA7
	2Mx32	4	RA0~RA10	CA0~CA7
128M bits	16Mx8	4	RA0~RA11	CA0~CA9
	8Mx16	4	RA0~RA11	CA0~CA8
	4Mx32	4	RA0~RA11	CA0~CA7
256M bits	32Mx8	4	RA0~RA12	CA0~CA9
	16Mx16	4	RA0~RA12	CA0~CA8

AHB Bus Address Mapping to SDRAM Bus

Note: * indicates the signal is not used; ** indicates the signal is fixed at logic 0 and is not used;

The HADDR prefixes have been omitted on the following tables.

A14 ~ A0 are the Address pins of the W90P710 EBI interface;

A14 and A13 are the Bank Select Signals of SDRAM.

SDRAM Data Bus Width: 32-bit

Total	Type	R x C	R/C	A14 (BS1)	A13 (BS0)	A12	A11	A10	A9	A8	A7	A6	A5	A4	A3	A2	A1	A0
16M	2Mx8	11x9	R	**	11	**	11*	22	21	20	19	18	17	16	15	14	13	12
			C	**	11	**	11*	AP	25*	10	9	8	7	6	5	4	3	2
16M	1Mx16	11x8	R	**	10	**	10*	11	21	20	19	18	17	16	15	14	13	12
			C	**	10	**	10*	AP	25*	10*	9	8	7	6	5	4	3	2
64M	8Mx8	12x9	R	11	12	11*	23	22	21	20	19	18	17	16	15	14	13	24
			C	11	12	11*	23*	AP	25*	10	9	8	7	6	5	4	3	2
64M	4Mx16	12x8	R	11	10	11*	23	22	21	20	19	18	17	16	15	14	13	12
			C	11	10	11*	23*	AP	25*	24*	9	8	7	6	5	4	3	2
64M	2Mx32	11x8	R	11	10	11*	23*	22	21	20	19	18	17	16	15	14	13	12
			C	11	10	11*	23*	AP	25*	24*	9	8	7	6	5	4	3	2
128M*	16Mx8	12x10	R	11	12	11*	23	22	21	20	19	18	17	16	15	14	13	24
			C	11	12	11*	23*	AP	25	10	9	8	7	6	5	4	3	2
128M	8Mx16	12x9	R	11	12	11*	23	22	21	20	19	18	17	16	15	14	13	24
			C	11	12	11*	23*	AP	25*	10	9	8	7	6	5	4	3	2
128M	4Mx32	12x8	R	11	10	11*	23	22	21	20	19	18	17	16	15	14	13	12
			C	11	10	11*	23*	AP	25*	10*	9	8	7	6	5	4	3	2
256M*	32Mx8	13x10	R	11	12	24	23	22	21	20	19	18	17	16	15	14	13	25
			C	11	12	24*	23*	AP	26*	10	9	8	7	6	5	4	3	2
256M*	16Mx16	13x9	R	11	12	24	23	22	21	20	19	18	17	16	15	14	13	25
			C	11	12	24*	23*	AP	26*	10*	9	8	7	6	5	4	3	2

W90P710CD/W90P710CDG



SDRAM Data Bus Width: 16-bit

Total	Type	R x C	R/C	A14 (BS1)	A13 (BS0)	A12	A11	A10	A9	A8	A7	A6	A5	A4	A3	A2	A1	A0
16M	2Mx8	11x9	R	**	10	**	10*	21	20	19	18	17	16	15	14	13	12	11
			C	**	10	**	10*	AP	24*	9	8	7	6	5	4	3	2	1
16M	1Mx16	11x8	R	**	9	**	9*	10	20	19	18	17	16	15	14	13	12	11
			C	**	9	**	9*	AP	24*	9*	8	7	6	5	4	3	2	1
64M	8Mx8	12x9	R	10	11	10*	22	21	20	19	18	17	16	15	14	13	12	23
			C	10	11	10*	22*	AP	24*	9	8	7	6	5	4	3	2	1
64M	4Mx16	12x8	R	10	9	10*	22	21	20	19	18	17	16	15	14	13	12	11
			C	10	9	10*	22*	AP	24*	23*	8	7	6	5	4	3	2	1
64M	2Mx32	11x8	R	10	9	10*	22*	21	20	19	18	17	16	15	14	13	12	11
			C	10	9	10*	22*	AP	24*	23*	8	7	6	5	4	3	2	1
128M	16Mx8	12x10	R	10	11	10*	22	21	20	19	18	17	16	15	14	13	12	23
			C	10	11	10*	22*	AP	24	9	8	7	6	5	4	3	2	1
128M	8Mx16	12x9	R	10	11	10*	22	21	20	19	18	17	16	15	14	13	12	23
			C	10	11	10*	22*	AP	24*	9	8	7	6	5	4	3	2	1
128M	4Mx32	12x8	R	10	9	10*	22	21	20	19	18	17	16	15	14	13	12	11
			C	10	9	10*	22*	AP	24*	9*	8	7	6	5	4	3	2	1
256M*	32Mx8	13x10	R	10	11	23	22	21	20	19	18	17	16	15	14	13	12	24
			C	10	11	23*	22*	AP	25*	9	8	7	6	5	4	3	2	1
256M	16Mx16	13x9	R	10	11	23	22	21	20	19	18	17	16	15	14	13	12	24
			C	10	11	23*	22*	AP	25*	9	8	7	6	5	4	3	2	1

W90P710CD/W90P710CDG



SDRAM Data Bus Width: 8-bit

Total	Type	R x C	R/C	A14 (BS1)	A13 (BS0)	A12	A11	A10	A9	A8	A7	A6	A5	A4	A3	A2	A1	A0
16M	2Mx8	11x9	R	**	9	**	9*	20	19	18	17	16	15	14	13	12	11	10
			C	**	9	**	9*	AP	23*	8	7	6	5	4	3	2	1	0
16M	1Mx16	11x8	R	**	8	**	8*	9	19	18	17	16	15	14	13	12	11	10
			C	**	8	**	8*	AP	23*	8*	7	6	5	4	3	2	1	0
64M	8Mx8	12x9	R	9	10	9*	21	20	19	18	17	16	15	14	13	12	11	22
			C	9	10	9*	21*	AP	23*	8	7	6	5	4	3	2	1	1
64M	4Mx16	12x8	R	9	8	9*	21	20	19	18	17	16	15	14	13	12	11	10
			C	9	8	9*	21*	AP	23*	22*	7	6	5	4	3	2	1	0
64M	2Mx32	11x8	R	9	8	9*	21*	20	19	18	17	16	15	14	13	12	11	10
			C	9	8	9*	21*	AP	23*	22*	7	6	5	4	3	2	1	0
128M	16Mx8	12x10	R	9	10	9*	21	20	19	18	17	16	15	14	13	12	11	22
			C	9	10	9*	21*	AP	23	8	7	6	5	4	3	2	1	0
128M	8Mx16	12x9	R	9	10	9*	21	20	19	18	17	16	15	14	13	12	11	22
			C	9	10	9*	21*	AP	23*	8	7	6	5	4	3	2	1	0
128M	4Mx32	12x8	R	9	8	9*	21	20	19	18	17	16	15	14	13	12	11	10
			C	9	8	9*	21*	AP	23*	8*	7	6	5	4	3	2	1	0
256M	32Mx8	13x10	R	9	10	22	21	20	19	18	17	16	15	14	13	12	11	23
			C	9	10	22*	21*	AP	24	8	7	6	5	4	3	2	1	0
256M	16Mx16	13x9	R	9	10	22	21	20	19	18	17	16	15	14	13	12	11	23
			C	9	10	22*	21*	AP	24*	8	7	6	5	4	3	2	1	0

6.3.2.2 SDRAM Power Up Sequence

SDRAM must be initialized after power-on. W90P710 SDRAM Controller automatically executes initialization and sets the mode register of each bank to default values. The default values are:

- Burst Length = 1
- Burst Type = Sequential (fixed)
- CAS Latency = 2
- Write Burst Length = Burst (fixed)

The value of mode register can be changed after the power-on sequence by setting the value of the corresponding bank's configuration register "LENGTH" and "LATENCY" bits and set the MRSET bit enable to execute the Mode Register Set command.

W90P710CD/W90P710CDG



6.3.2.3 SDRAM Interface

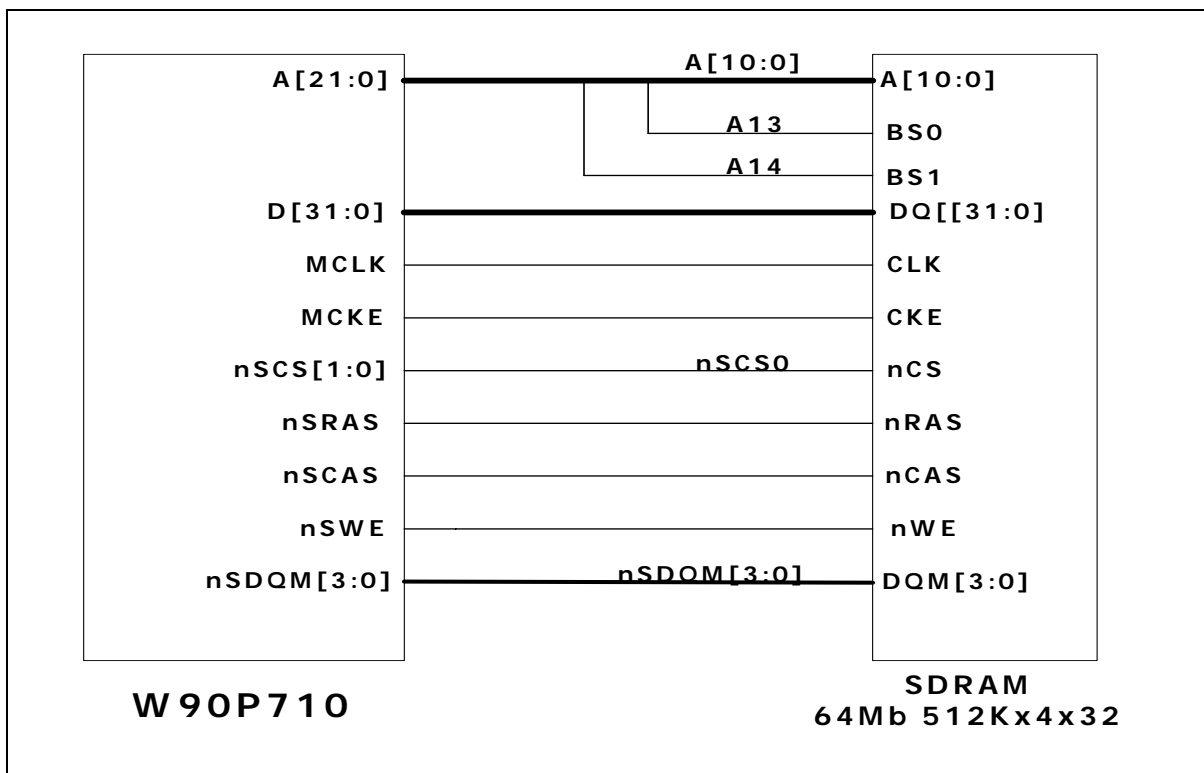

Fig 6.3.1 SDRAM Interface

6.3.3 EBI Control Registers Map

REGISTER	ADDRESS	R/W	DESCRIPTION	RESET VALUE
EBICON	0xFFFF0_1000	R/W	EBI control register	0x0001_0000
ROMCON	0xFFFF0_1004	R/W	ROM/FLASH control register	0x0000_0XFC
SDCONF0	0xFFFF0_1008	R/W	SDRAM bank 0 configuration register	0x0000_0800
SDCONF1	0xFFFF0_100C	R/W	SDRAM bank 1 configuration register	0x0000_0800
SDTIME0	0xFFFF0_1010	R/W	SDRAM bank 0 timing control register	0x0000_0000
SDTIME1	0xFFFF0_1014	R/W	SDRAM bank 1 timing control register	0x0000_0000
EXT0CON	0xFFFF0_1018	R/W	External I/O 0 control register	0x0000_0000
EXT1CON	0xFFFF0_101C	R/W	External I/O 1 control register	0x0000_0000
EXT2CON	0xFFFF0_1020	R/W	External I/O 2 control register	0x0000_0000
EXT3CON	0xFFFF0_1024	R/W	External I/O 3 control register	0x0000_0000
CKSKEW	0xFFFF0_1F00	R/W	Clock skew control register (for testing)	0xFFFF_0038

W90P710CD/W90P710CDG



EBI Control Register (EBICON)

REGISTER	ADDRESS	R/W	DESCRIPTION	RESET VALUE
EBICON	0xFFFF0_1000	R/W	EBI control register	0x0001_0000

31	30	29	28	27	26	25	24
RESERVED				EXBE3	EXBE2	EXBE1	EXBE0
23	22	21	20	19	18	17	16
RESERVED					REFEN	REFMOD	CLKEN
15	14	13	12	11	10	9	8
REFRAT							
7	6	5	4	3	2	1	0
REFRAT					WAITVT		LITTLE

BITS	DESCRIPTION	
[31:28]	RESERVED	
[27]	EXBE3	<p>External IO bank 3 byte enable</p> <p>This function is used for some devices that with high and low bytes enable signals to control which byte will be written or masked data output when read. For this kind device, software can set this bit HIGH to implement this function. Detail pin interconnection is showed as Fig6.3.8.</p> <p>1 = nWBE[3:0] pin is byte enable signals, nWE will be used as write strobe signal to SRAM.</p> <p>0 = nWBE[3:0] pin is byte write strobe signal.</p>
[26]	EXBE2	<p>External IO bank 2 byte enable</p> <p>The bit function description is the same as EXBE3 above.</p> <p>1 = nWBE[3:0] pin is byte enable signals, nWE will be used as write strobe signal to SRAM.</p> <p>0 = nWBE[3:0] pin is byte write strobe signal.</p>
[25]	EXBE1	<p>External IO bank 1 byte enable</p> <p>The bit function description is the same as EXBE3 above.</p> <p>1 = nWBE[3:0] pin is byte enable signals, nWE will be used as write strobe signal to SRAM</p> <p>0 = nWBE[3:0] pin is byte write strobe signal</p>

W90P710CD/W90P710CDG



Continued.

BITS	DESCRIPTION	
[24]	EXBE0	<p>External IO bank 0 byte enable</p> <p>The function description for this bit is the same as EXBE3 above.</p> <p>1 = nWBE[3:0] pin is byte enable signals, nWE will be used as write strobe signal to SRAM</p> <p>0 = nWBE[3:0] pin is byte write strobe signal</p>
[23:19]	RESERVED	
[18]	REFEN	<p>Enable SDRAM refresh cycle for SDRAM bank0 & bank1</p> <p>Set this bit to start the SDRAM auto-refresh cycle. The refresh rate is according to the REFRAT bits.</p> <p>1 = Enable refresh function</p> <p>0 = Disable refresh function</p>
[17]	REFMOD	<p>Refresh mode of SDRAM for SDRAM bank</p> <p>Defines the refresh mode type of external SDRAM bank</p> <p>Software can write this bit "1" to force SDRAM enter self-refresh mode.</p> <p>0 = Auto refresh mode</p> <p>1 = Self refresh mode</p> <p>NOTE: If any read/write to SDRAM occurs then this bit will be automatically cleared to "0" by hardware, and SDRAM will enter auto-refresh mode.</p>
[16]	CLKEN	<p>Clock enable for SDRAM</p> <p>Enables the SDRAM clock enable (CKE) control signal</p> <p>0 = Disable (power down mode)</p> <p>1 = Enable (Default)</p>
[15:3]	REFRAT	<p>Refresh count value for SDRAM</p> <p>The SDRAM Controller provides an auto-refresh cycle for every refresh period stored in the REFRAT bits when the REFEN bit of each bank is set.</p> <p>The refresh period is calculated as $period = \frac{value}{fMCLK}$</p>

W90P710CD/W90P710CDG



Continued.

BITS	DESCRIPTION																
[2:1]	WAITVT	<p>Valid time of nWAIT signal W90P710 recognizes the nWAIT signal at the “nth” MCLK positive edge after the nOE or nWBE active cycle. WAITVT bits determine n.</p> <table border="1" data-bbox="678 520 1230 718"> <thead> <tr> <th colspan="2">WAITVT [2:1]</th> <th>nth MCLK</th> </tr> </thead> <tbody> <tr> <td>0</td> <td>0</td> <td>1</td> </tr> <tr> <td>0</td> <td>1</td> <td>2</td> </tr> <tr> <td>1</td> <td>0</td> <td>3</td> </tr> <tr> <td>1</td> <td>1</td> <td>4</td> </tr> </tbody> </table>	WAITVT [2:1]		n th MCLK	0	0	1	0	1	2	1	0	3	1	1	4
WAITVT [2:1]		n th MCLK															
0	0	1															
0	1	2															
1	0	3															
1	1	4															
[0]	LITTLE	<p>Little-endian mode After power on reset, the content of LITTLE is the Power-On Setting value from D14 pin. If pin D14 is pulled down, the external memory format is Big-endian mode. If pin D14 is pulled up, the external memory format is Little-endian mode. For more details, refer to Power-On Setting of System Manager.</p> <p>NOTE: This bit is read only.</p>															

ROM/Flash Control Register (ROMCON)

REGISTER	ADDRESS	R/W	DESCRIPTION	RESET VALUE
ROMCON	0xFFFF0_1004	R/W	ROM/FLASH control register	0x0000_0XFC

31	30	29	28	27	26	25	24
BASADDR							
23	22	21	20	19	18	17	16
BASADDR				SIZE			
15	14	13	12	11	10	9	8
RESERVED				tPA			
7	6	5	4	3	2	1	0
tACC				BTSIZE		PGMODE	

W90P710CD/W90P710CDG



BITS		DESCRIPTION																																																																																											
[31:19]	BASADDR	Base address pointer of ROM/Flash bank The start address is calculated as ROM/Flash bank base pointer << 18. The base address pointer together with the "SIZE" bits constitutes the whole address range of each bank.																																																																																											
[18:16]	SIZE	The size of ROM/FLASH memory <table border="1" style="margin-left: 20px;"> <thead> <tr> <th colspan="3">SIZE [10:8]</th> <th>Byte</th> </tr> </thead> <tbody> <tr><td>0</td><td>0</td><td>0</td><td>256K</td></tr> <tr><td>0</td><td>0</td><td>1</td><td>512K</td></tr> <tr><td>0</td><td>1</td><td>0</td><td>1M</td></tr> <tr><td>0</td><td>1</td><td>1</td><td>2M</td></tr> <tr><td>1</td><td>0</td><td>0</td><td>4M</td></tr> <tr><td>1</td><td>0</td><td>1</td><td>8M</td></tr> <tr><td>1</td><td>1</td><td>0</td><td>16M</td></tr> <tr><td>1</td><td>1</td><td>1</td><td>RESERVED</td></tr> </tbody> </table>		SIZE [10:8]			Byte	0	0	0	256K	0	0	1	512K	0	1	0	1M	0	1	1	2M	1	0	0	4M	1	0	1	8M	1	1	0	16M	1	1	1	RESERVED																																																						
SIZE [10:8]			Byte																																																																																										
0	0	0	256K																																																																																										
0	0	1	512K																																																																																										
0	1	0	1M																																																																																										
0	1	1	2M																																																																																										
1	0	0	4M																																																																																										
1	0	1	8M																																																																																										
1	1	0	16M																																																																																										
1	1	1	RESERVED																																																																																										
[15:12]	RESERVED	-																																																																																											
[11:8]	tPA	Page mode access cycle time <table border="1" style="margin-left: 20px;"> <thead> <tr> <th colspan="4">tPA[11:8]</th> <th>MCLK</th> <th colspan="4">tPA[11:8]</th> <th>MCLK</th> </tr> </thead> <tbody> <tr><td>0</td><td>0</td><td>0</td><td>0</td><td>1</td><td>1</td><td>0</td><td>0</td><td>0</td><td>10</td></tr> <tr><td>0</td><td>0</td><td>0</td><td>1</td><td>2</td><td>1</td><td>0</td><td>0</td><td>1</td><td>12</td></tr> <tr><td>0</td><td>0</td><td>1</td><td>0</td><td>3</td><td>1</td><td>0</td><td>1</td><td>0</td><td>14</td></tr> <tr><td>0</td><td>0</td><td>1</td><td>1</td><td>4</td><td>1</td><td>0</td><td>1</td><td>1</td><td>16</td></tr> <tr><td>0</td><td>1</td><td>0</td><td>0</td><td>5</td><td>1</td><td>1</td><td>0</td><td>0</td><td>18</td></tr> <tr><td>0</td><td>1</td><td>0</td><td>1</td><td>6</td><td>1</td><td>1</td><td>0</td><td>1</td><td>20</td></tr> <tr><td>0</td><td>1</td><td>1</td><td>0</td><td>7</td><td>1</td><td>1</td><td>1</td><td>0</td><td>22</td></tr> <tr><td>0</td><td>1</td><td>1</td><td>1</td><td>8</td><td>1</td><td>1</td><td>1</td><td>1</td><td>24</td></tr> </tbody> </table>		tPA[11:8]				MCLK	tPA[11:8]				MCLK	0	0	0	0	1	1	0	0	0	10	0	0	0	1	2	1	0	0	1	12	0	0	1	0	3	1	0	1	0	14	0	0	1	1	4	1	0	1	1	16	0	1	0	0	5	1	1	0	0	18	0	1	0	1	6	1	1	0	1	20	0	1	1	0	7	1	1	1	0	22	0	1	1	1	8	1	1	1	1	24
tPA[11:8]				MCLK	tPA[11:8]				MCLK																																																																																				
0	0	0	0	1	1	0	0	0	10																																																																																				
0	0	0	1	2	1	0	0	1	12																																																																																				
0	0	1	0	3	1	0	1	0	14																																																																																				
0	0	1	1	4	1	0	1	1	16																																																																																				
0	1	0	0	5	1	1	0	0	18																																																																																				
0	1	0	1	6	1	1	0	1	20																																																																																				
0	1	1	0	7	1	1	1	0	22																																																																																				
0	1	1	1	8	1	1	1	1	24																																																																																				
[7:4]	tACC	Access cycle time <table border="1" style="margin-left: 20px;"> <thead> <tr> <th colspan="4">tACC[11:8]</th> <th>MCLK</th> <th colspan="4">tACC[11:8]</th> <th>MCLK</th> </tr> </thead> <tbody> <tr><td>0</td><td>0</td><td>0</td><td>0</td><td>1</td><td>1</td><td>0</td><td>0</td><td>0</td><td>10</td></tr> <tr><td>0</td><td>0</td><td>0</td><td>1</td><td>2</td><td>1</td><td>0</td><td>0</td><td>1</td><td>12</td></tr> <tr><td>0</td><td>0</td><td>1</td><td>0</td><td>3</td><td>1</td><td>0</td><td>1</td><td>0</td><td>14</td></tr> <tr><td>0</td><td>0</td><td>1</td><td>1</td><td>4</td><td>1</td><td>0</td><td>1</td><td>1</td><td>16</td></tr> <tr><td>0</td><td>1</td><td>0</td><td>0</td><td>5</td><td>1</td><td>1</td><td>0</td><td>0</td><td>18</td></tr> <tr><td>0</td><td>1</td><td>0</td><td>1</td><td>6</td><td>1</td><td>1</td><td>0</td><td>1</td><td>20</td></tr> <tr><td>0</td><td>1</td><td>1</td><td>0</td><td>7</td><td>1</td><td>1</td><td>1</td><td>0</td><td>22</td></tr> <tr><td>0</td><td>1</td><td>1</td><td>1</td><td>8</td><td>1</td><td>1</td><td>1</td><td>1</td><td>24</td></tr> </tbody> </table>		tACC[11:8]				MCLK	tACC[11:8]				MCLK	0	0	0	0	1	1	0	0	0	10	0	0	0	1	2	1	0	0	1	12	0	0	1	0	3	1	0	1	0	14	0	0	1	1	4	1	0	1	1	16	0	1	0	0	5	1	1	0	0	18	0	1	0	1	6	1	1	0	1	20	0	1	1	0	7	1	1	1	0	22	0	1	1	1	8	1	1	1	1	24
tACC[11:8]				MCLK	tACC[11:8]				MCLK																																																																																				
0	0	0	0	1	1	0	0	0	10																																																																																				
0	0	0	1	2	1	0	0	1	12																																																																																				
0	0	1	0	3	1	0	1	0	14																																																																																				
0	0	1	1	4	1	0	1	1	16																																																																																				
0	1	0	0	5	1	1	0	0	18																																																																																				
0	1	0	1	6	1	1	0	1	20																																																																																				
0	1	1	0	7	1	1	1	0	22																																																																																				
0	1	1	1	8	1	1	1	1	24																																																																																				

W90P710CD/W90P710CDG



Continued.

BITS	DESCRIPTION																										
[3:2]	BTSIZE	<p>Boot ROM/FLASH data bus width</p> <p>This ROM/Flash bank is designed for a boot ROM. BASADDR bits determine its start address. The external data bus width is determined by the data bus signals D [13:12] power-on setting.</p> <table border="1"> <thead> <tr> <th>BTSIZE [3:2]</th> <th>Bus Width</th> <th colspan="2">D [13:12]</th> <th>Bus Width</th> </tr> </thead> <tbody> <tr> <td>0</td> <td>0</td> <td>Pull-down</td> <td>Pull-down</td> <td>8-bit</td> </tr> <tr> <td>0</td> <td>1</td> <td>Pull-down</td> <td>Pull-up</td> <td>16-bit</td> </tr> <tr> <td>1</td> <td>0</td> <td>Pull-up</td> <td>Pull-down</td> <td>32-bit</td> </tr> <tr> <td>1</td> <td>1</td> <td>RESERVED</td> <td>Pull-up</td> <td>RESERVED</td> </tr> </tbody> </table>	BTSIZE [3:2]	Bus Width	D [13:12]		Bus Width	0	0	Pull-down	Pull-down	8-bit	0	1	Pull-down	Pull-up	16-bit	1	0	Pull-up	Pull-down	32-bit	1	1	RESERVED	Pull-up	RESERVED
BTSIZE [3:2]	Bus Width	D [13:12]		Bus Width																							
0	0	Pull-down	Pull-down	8-bit																							
0	1	Pull-down	Pull-up	16-bit																							
1	0	Pull-up	Pull-down	32-bit																							
1	1	RESERVED	Pull-up	RESERVED																							
[1:0]	PGMODE	<p>Page mode configuration</p> <table border="1"> <thead> <tr> <th colspan="2">PGMODE [1:0]</th> <th>Mode</th> </tr> </thead> <tbody> <tr> <td>0</td> <td>0</td> <td>Normal ROM</td> </tr> <tr> <td>0</td> <td>1</td> <td>4 word page</td> </tr> <tr> <td>1</td> <td>0</td> <td>8 word page</td> </tr> <tr> <td>1</td> <td>1</td> <td>16 word page</td> </tr> </tbody> </table>	PGMODE [1:0]		Mode	0	0	Normal ROM	0	1	4 word page	1	0	8 word page	1	1	16 word page										
PGMODE [1:0]		Mode																									
0	0	Normal ROM																									
0	1	4 word page																									
1	0	8 word page																									
1	1	16 word page																									

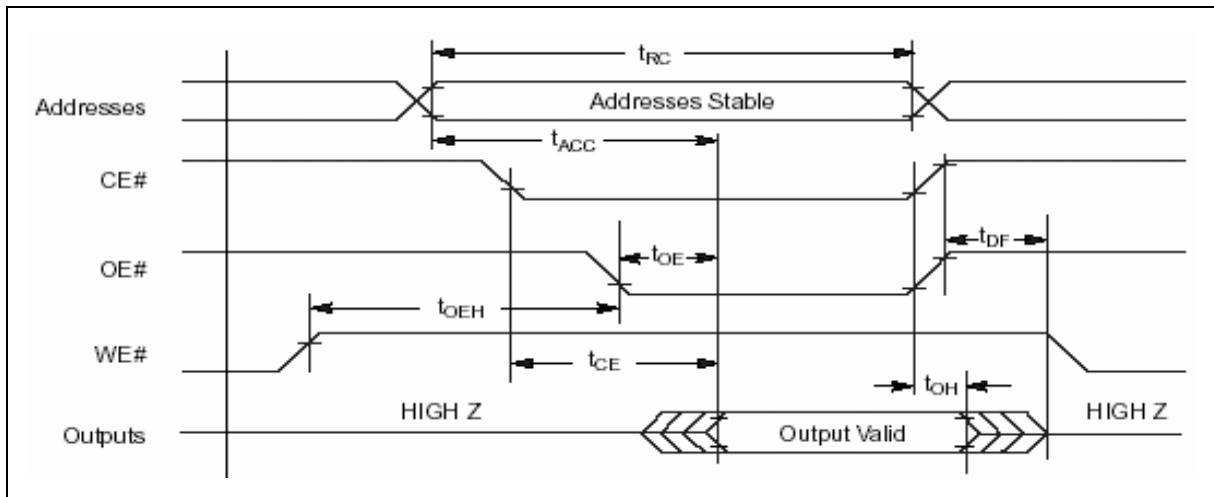

Fig6.3.2 ROM/FLASH Read Operation Timing

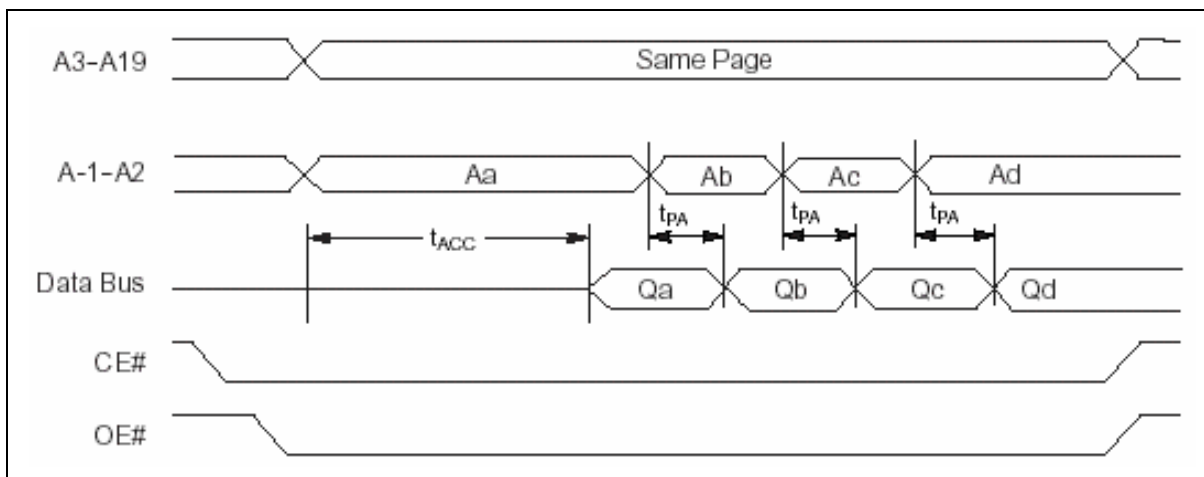

Fig 6.3.3 ROM/FLASH Page Read Operation Timing

Configuration Registers (SDCONF0/1)

The configuration registers enable software to set a number of operating parameters for the SDRAM controller. There are two configuration registers SDCONF0, SDCONF1 for SDRAM bank 0, bank 1 respectively. Each bank can have a different configuration.

REGISTER	ADDRESS	R/W	DESCRIPTION	RESET VALUE
SDCONF0	0xFFFF0_1008	R/W	SDRAM bank 0 configuration register	0x0000_0800
SDCONF1	0xFFFF0_100C	R/W	SDRAM bank 1 configuration register	0x0000_0800

31	30	29	28	27	26	25	24
BASADDR							
23	22	21	20	19	18	17	16
BASADDR					RESERVED		
15	14	13	12	11	10	9	8
MRSET	RESERVED	AUTOPR	LATENCY		RESERVED		
7	6	5	4	3	2	1	0
COMPBK	DBWD		COLUMN		SIZE		



BITS	DESCRIPTION																
[31:19]	BASADDR	Base address pointer of SDRAM bank 0/1 The start address is calculated as SDRAM bank 0/1 base pointer << 18. The SDRAM base address pointer together with the "SIZE" bits constitutes the whole address range of each SDRAM bank.															
[18:16]	RESERVED	-															
[15]	MRSET	SDRAM Mode register set command for SDRAM bank 0/1 Set this bit to issue a mode register set command to SDRAM.															
[14]	RESERVED	-															
[13]	AUTOPR	SDRAM bank 0/1 auto precharge mode Enable the auto precharge function of external SDRAM bank 0/1 1= Auto precharge 0 = No auto precharge															
[12:11]	LATENCY	The CAS Latency of SDRAM bank 0/1 Defines the CAS latency of external SDRAM bank 0/1 <table border="1" data-bbox="685 953 1330 1157"> <thead> <tr> <th colspan="2">LATENCY [12:11]</th> <th>MCLK</th> </tr> </thead> <tbody> <tr> <td>0</td> <td>0</td> <td>1</td> </tr> <tr> <td>0</td> <td>1</td> <td>2</td> </tr> <tr> <td>1</td> <td>0</td> <td>3</td> </tr> <tr> <td>1</td> <td>1</td> <td>REVERSED</td> </tr> </tbody> </table>	LATENCY [12:11]		MCLK	0	0	1	0	1	2	1	0	3	1	1	REVERSED
LATENCY [12:11]		MCLK															
0	0	1															
0	1	2															
1	0	3															
1	1	REVERSED															
[10:8]	RESERVED	-															
[7]	COMPBK	Number of component bank in SDRAM bank 0/1 Indicates the number of component bank (2 or 4 banks) in external SDRAM bank 0/1. 0 = 2 banks 1 = 4 banks															
[6:5]	DBWD	Data bus width for SDRAM bank 0/1 Indicates the external data bus width connect with SDRAM bank 0/1 If DBWD = 00, the assigned SDRAM access signal is not generated i.e. disable. <table border="1" data-bbox="685 1560 1330 1776"> <thead> <tr> <th colspan="2">DBWD [6:5]</th> <th>Bits</th> </tr> </thead> <tbody> <tr> <td>0</td> <td>0</td> <td>Bank disable</td> </tr> <tr> <td>0</td> <td>1</td> <td>8-bit (byte)</td> </tr> <tr> <td>1</td> <td>0</td> <td>16-bit (half-word)</td> </tr> <tr> <td>1</td> <td>1</td> <td>32-bit (word)</td> </tr> </tbody> </table>	DBWD [6:5]		Bits	0	0	Bank disable	0	1	8-bit (byte)	1	0	16-bit (half-word)	1	1	32-bit (word)
DBWD [6:5]		Bits															
0	0	Bank disable															
0	1	8-bit (byte)															
1	0	16-bit (half-word)															
1	1	32-bit (word)															

W90P710CD/W90P710CDG



Continued.

BITS	DESCRIPTION																																						
[4:3]	COLUMN	<p>Number of column address bits in SDRAM bank 0/1 Indicates the number of column address bits in external SDRAM bank 0/1.</p> <table border="1" data-bbox="695 510 1317 724"> <thead> <tr> <th colspan="2">COLUMN [4:3]</th> <th>Bits</th> </tr> </thead> <tbody> <tr> <td>0</td> <td>0</td> <td>8</td> </tr> <tr> <td>0</td> <td>1</td> <td>9</td> </tr> <tr> <td>1</td> <td>0</td> <td>10</td> </tr> <tr> <td>1</td> <td>1</td> <td>REVERSED</td> </tr> </tbody> </table>		COLUMN [4:3]		Bits	0	0	8	0	1	9	1	0	10	1	1	REVERSED																					
COLUMN [4:3]		Bits																																					
0	0	8																																					
0	1	9																																					
1	0	10																																					
1	1	REVERSED																																					
[2:0]	SIZE	<p>Size of SDRAM bank 0/1 Indicates the memory size of external SDRAM bank 0/1</p> <table border="1" data-bbox="695 821 1317 1188"> <thead> <tr> <th colspan="3">SIZE [2:0]</th> <th>Size of SDRAM (Byte)</th> </tr> </thead> <tbody> <tr> <td>0</td> <td>0</td> <td>0</td> <td>Bank disable</td> </tr> <tr> <td>0</td> <td>0</td> <td>1</td> <td>2M</td> </tr> <tr> <td>0</td> <td>1</td> <td>0</td> <td>4M</td> </tr> <tr> <td>0</td> <td>1</td> <td>1</td> <td>8M</td> </tr> <tr> <td>1</td> <td>0</td> <td>0</td> <td>16M</td> </tr> <tr> <td>1</td> <td>0</td> <td>1</td> <td>32M</td> </tr> <tr> <td>1</td> <td>1</td> <td>0</td> <td>64M</td> </tr> <tr> <td>1</td> <td>1</td> <td>1</td> <td>REVERSED</td> </tr> </tbody> </table>		SIZE [2:0]			Size of SDRAM (Byte)	0	0	0	Bank disable	0	0	1	2M	0	1	0	4M	0	1	1	8M	1	0	0	16M	1	0	1	32M	1	1	0	64M	1	1	1	REVERSED
SIZE [2:0]			Size of SDRAM (Byte)																																				
0	0	0	Bank disable																																				
0	0	1	2M																																				
0	1	0	4M																																				
0	1	1	8M																																				
1	0	0	16M																																				
1	0	1	32M																																				
1	1	0	64M																																				
1	1	1	REVERSED																																				

Timing Control Registers (SDTIME0/1)

W90P710 offers the flexible timing control registers to control the generation and processing of the control signals and can achieve you use different speed of SDRAM

REGISTER	ADDRESS	R/W	DESCRIPTION	RESET VALUE
SDTIME0	0xFFFF0_1010	R/W	SDRAM bank 0 timing control register	0x0000_0000
SDTIME1	0xFFFF0_1014	R/W	SDRAM bank 1 timing control register	0x0000_0000

W90P710CD/W90P710CDG



31	30	29	28	27	26	25	24
RESERVED							
23	22	21	20	19	18	17	16
RESERVED							
15	14	13	12	11	10	9	8
RESERVED					tRCD		
7	6	5	4	3	2	1	0
tRDL		tRP			tRAS		

BITS	DESCRIPTION																																					
[31:11]	RESERVED	-																																				
[10:8]	tRCD	<p>SDRAM bank 0/1, /RAS to /CAS delay</p> <table border="1"> <thead> <tr> <th colspan="3">tRCD [10:8]</th><th>MCLK</th></tr> </thead> <tbody> <tr><td>0</td><td>0</td><td>0</td><td>1</td></tr> <tr><td>0</td><td>0</td><td>1</td><td>2</td></tr> <tr><td>0</td><td>1</td><td>0</td><td>3</td></tr> <tr><td>0</td><td>1</td><td>1</td><td>4</td></tr> <tr><td>1</td><td>0</td><td>0</td><td>5</td></tr> <tr><td>1</td><td>0</td><td>1</td><td>6</td></tr> <tr><td>1</td><td>1</td><td>0</td><td>7</td></tr> <tr><td>1</td><td>1</td><td>1</td><td>8</td></tr> </tbody> </table>	tRCD [10:8]			MCLK	0	0	0	1	0	0	1	2	0	1	0	3	0	1	1	4	1	0	0	5	1	0	1	6	1	1	0	7	1	1	1	8
tRCD [10:8]			MCLK																																			
0	0	0	1																																			
0	0	1	2																																			
0	1	0	3																																			
0	1	1	4																																			
1	0	0	5																																			
1	0	1	6																																			
1	1	0	7																																			
1	1	1	8																																			
[7:6]	tRDL	<p>SDRAM bank 0/1, Last data in to precharge command</p> <table border="1"> <thead> <tr> <th colspan="2">tRDL [7:6]</th><th>MCLK</th></tr> </thead> <tbody> <tr><td>0</td><td>0</td><td>1</td></tr> <tr><td>0</td><td>1</td><td>2</td></tr> <tr><td>1</td><td>0</td><td>3</td></tr> <tr><td>1</td><td>1</td><td>4</td></tr> </tbody> </table>	tRDL [7:6]		MCLK	0	0	1	0	1	2	1	0	3	1	1	4																					
tRDL [7:6]		MCLK																																				
0	0	1																																				
0	1	2																																				
1	0	3																																				
1	1	4																																				
[5:3]	tRP	<p>SDRAM bank 0/1, Row precharge time</p> <table border="1"> <thead> <tr> <th colspan="3">tRP [5:3]</th><th>MCLK</th></tr> </thead> <tbody> <tr><td>0</td><td>0</td><td>0</td><td>1</td></tr> <tr><td>0</td><td>0</td><td>1</td><td>2</td></tr> <tr><td>0</td><td>1</td><td>0</td><td>3</td></tr> <tr><td>0</td><td>1</td><td>1</td><td>4</td></tr> <tr><td>1</td><td>0</td><td>0</td><td>5</td></tr> <tr><td>1</td><td>0</td><td>1</td><td>6</td></tr> <tr><td>1</td><td>1</td><td>0</td><td>7</td></tr> <tr><td>1</td><td>1</td><td>1</td><td>8</td></tr> </tbody> </table>	tRP [5:3]			MCLK	0	0	0	1	0	0	1	2	0	1	0	3	0	1	1	4	1	0	0	5	1	0	1	6	1	1	0	7	1	1	1	8
tRP [5:3]			MCLK																																			
0	0	0	1																																			
0	0	1	2																																			
0	1	0	3																																			
0	1	1	4																																			
1	0	0	5																																			
1	0	1	6																																			
1	1	0	7																																			
1	1	1	8																																			

W90P710CD/W90P710CDG



Continued.

BITS	DESCRIPTION				
[2:0]	tRAS	SDRAM bank 0/1, Row active time			
		tRAS [2:0]		MCLK	
		0	0	0	1
		0	0	1	2
		0	1	0	3
		0	1	1	4
		1	0	0	5
		1	0	1	6
		1	1	0	7
1	1	1	8		

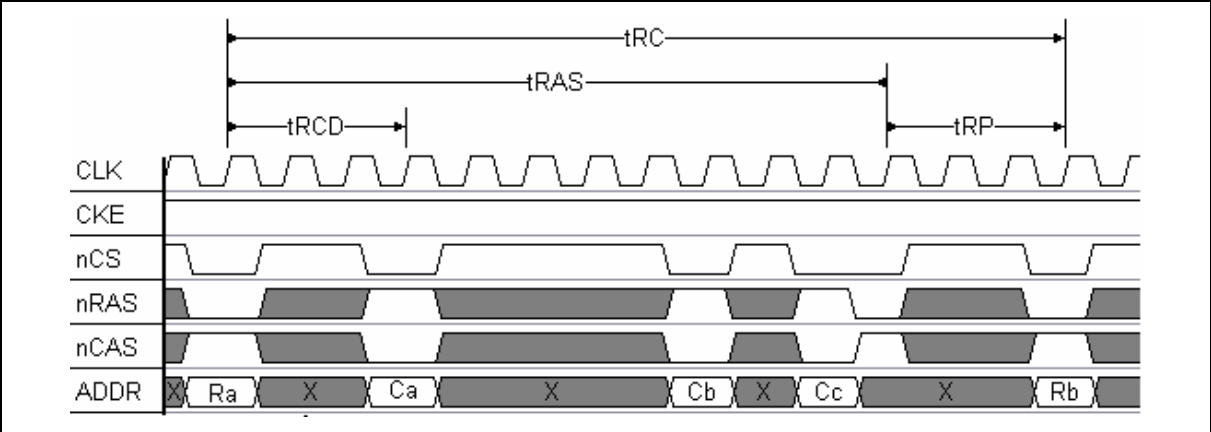

Fig 6.3.4 Access timing 1 of SDRAM

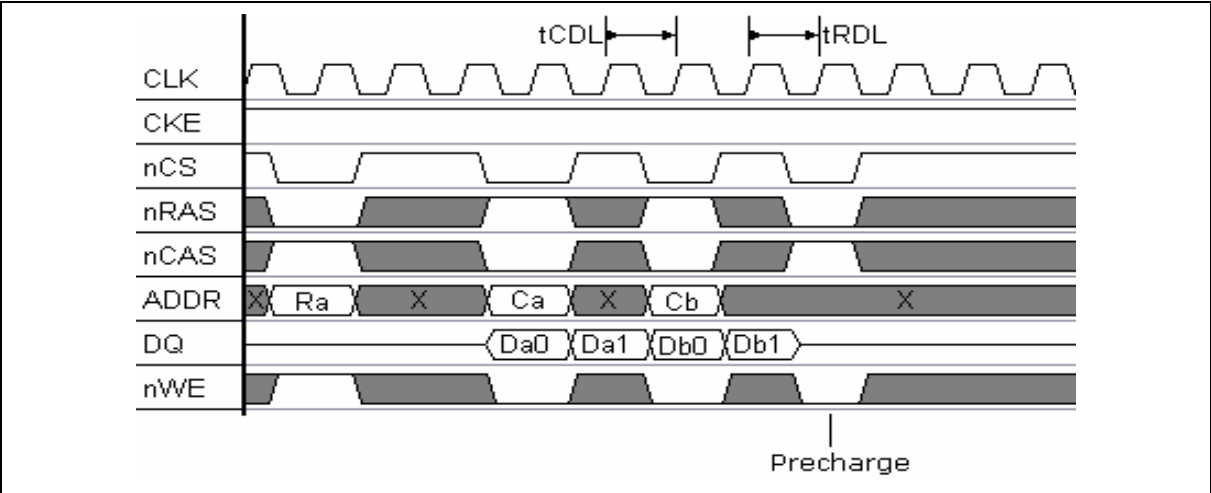

Fig 6.3.5 Access timing 2 of SDRAM

W90P710CD/W90P710CDG



External I/O Control Registers (EXT0CON – EXT3CON)

The W90P710 supports an external device control without glue logic. It is very cost effective because address decoding and control signals timing logic are not needed. Using these control registers you can configure special external I/O devices for providing the low cost external devices control solution.

REGISTER	ADDRESS	R/W	DESCRIPTION	RESET VALUE
EXT0CON	0xFFFF0_1018	R/W	External I/O 0 control register	0x0000_0000
EXT1CON	0xFFFF0_101C	R/W	External I/O 1 control register	0x0000_0000
EXT2CON	0xFFFF0_1020	R/W	External I/O 2 control register	0x0000_0000
EXT3CON	0xFFFF0_1024	R/W	External I/O 3 control register	0x0000_0000

31	30	29	28	27	26	25	24
BASADDR							
23	22	21	20	19	18	17	16
BASADDR					SIZE		
15	14	13	12	11	10	9	8
ADRS		tACC				tCOH	
7	6	5	4	3	2	1	0
tACS			tCOS			DBWD	

BITS	DESCRIPTION																																					
[31:11]	BASADDR	<p>Base address pointer of external I/O bank 0~3</p> <p>The start address of each external I/O bank is calculated as “BASADDR” base pointer << 18.</p> <p>Each external I/O bank base address pointer together with the “SIZE” bits constitutes the whole address range of each external I/O bank.</p>																																				
[18:16]	SIZE	<p>The size of the external I/O bank 0~3</p> <table border="1" style="margin-left: 20px;"> <thead> <tr> <th colspan="3">SIZE [18:16]</th> <th>Byte</th> </tr> </thead> <tbody> <tr> <td>0</td> <td>0</td> <td>0</td> <td>256K</td> </tr> <tr> <td>0</td> <td>0</td> <td>1</td> <td>512K</td> </tr> <tr> <td>0</td> <td>1</td> <td>0</td> <td>1M</td> </tr> <tr> <td>0</td> <td>1</td> <td>1</td> <td>2M</td> </tr> <tr> <td>1</td> <td>0</td> <td>0</td> <td>4M</td> </tr> <tr> <td>1</td> <td>0</td> <td>1</td> <td>8M</td> </tr> <tr> <td>1</td> <td>1</td> <td>0</td> <td>16M</td> </tr> <tr> <td>1</td> <td>1</td> <td>1</td> <td>REVERSED</td> </tr> </tbody> </table>	SIZE [18:16]			Byte	0	0	0	256K	0	0	1	512K	0	1	0	1M	0	1	1	2M	1	0	0	4M	1	0	1	8M	1	1	0	16M	1	1	1	REVERSED
SIZE [18:16]			Byte																																			
0	0	0	256K																																			
0	0	1	512K																																			
0	1	0	1M																																			
0	1	1	2M																																			
1	0	0	4M																																			
1	0	1	8M																																			
1	1	0	16M																																			
1	1	1	REVERSED																																			

W90P710CD/W90P710CDG



Continued.

BITS		DESCRIPTION																																																																																										
[15]	ADRS	<p>Address bus alignment for external I/O bank 0~3</p> <p>When ADRS is set, external address (A21~A0) bus is alignment to byte address format, that is, A0 is internal AHB address bus HADDR[0] and A1 is AHB bus HADDR[1] and so forth. And it ignores DBWD [1:0] setting.</p>																																																																																										
[14:11]	tACC	<p>Access cycles of external I/O bank 0~3</p> <p>This parameter means nWE, nWBE and nOE active time clock. For a detailed timing diagram please refer to Fig. 6.3.6 and 6.3.7</p> <table border="1"> <thead> <tr> <th colspan="4">tACC[14:11]</th> <th>MCLK</th> <th colspan="4">tACC[14:11]</th> <th>MCLK</th> </tr> </thead> <tbody> <tr> <td>0</td><td>0</td><td>0</td><td>0</td> <td>Reversed</td> <td>1</td><td>0</td><td>0</td><td>0</td> <td>9</td> </tr> <tr> <td>0</td><td>0</td><td>0</td><td>1</td> <td>1</td> <td>1</td><td>0</td><td>0</td><td>1</td> <td>11</td> </tr> <tr> <td>0</td><td>0</td><td>1</td><td>0</td> <td>2</td> <td>1</td><td>0</td><td>1</td><td>0</td> <td>13</td> </tr> <tr> <td>0</td><td>0</td><td>1</td><td>1</td> <td>3</td> <td>1</td><td>0</td><td>1</td><td>1</td> <td>15</td> </tr> <tr> <td>0</td><td>1</td><td>0</td><td>0</td> <td>4</td> <td>1</td><td>1</td><td>0</td><td>0</td> <td>17</td> </tr> <tr> <td>0</td><td>1</td><td>0</td><td>1</td> <td>5</td> <td>1</td><td>1</td><td>0</td><td>1</td> <td>19</td> </tr> <tr> <td>0</td><td>1</td><td>1</td><td>0</td> <td>6</td> <td>1</td><td>1</td><td>1</td><td>0</td> <td>21</td> </tr> <tr> <td>0</td><td>1</td><td>1</td><td>1</td> <td>7</td> <td>1</td><td>1</td><td>1</td><td>1</td> <td>23</td> </tr> </tbody> </table>	tACC[14:11]				MCLK	tACC[14:11]				MCLK	0	0	0	0	Reversed	1	0	0	0	9	0	0	0	1	1	1	0	0	1	11	0	0	1	0	2	1	0	1	0	13	0	0	1	1	3	1	0	1	1	15	0	1	0	0	4	1	1	0	0	17	0	1	0	1	5	1	1	0	1	19	0	1	1	0	6	1	1	1	0	21	0	1	1	1	7	1	1	1	1	23
tACC[14:11]				MCLK	tACC[14:11]				MCLK																																																																																			
0	0	0	0	Reversed	1	0	0	0	9																																																																																			
0	0	0	1	1	1	0	0	1	11																																																																																			
0	0	1	0	2	1	0	1	0	13																																																																																			
0	0	1	1	3	1	0	1	1	15																																																																																			
0	1	0	0	4	1	1	0	0	17																																																																																			
0	1	0	1	5	1	1	0	1	19																																																																																			
0	1	1	0	6	1	1	1	0	21																																																																																			
0	1	1	1	7	1	1	1	1	23																																																																																			
[10:8]	tCOH	<p>Chip selection hold time of external I/O bank 0~3</p> <p>This parameters control nWBE and nOE hold time. For a detailed timing diagram please refer to Fig. 6.3.6 and 6.3.7</p> <table border="1"> <thead> <tr> <th colspan="3">tCOH [10:8]</th> <th>MCLK</th> </tr> </thead> <tbody> <tr> <td>0</td><td>0</td><td>0</td> <td>0</td> </tr> <tr> <td>0</td><td>0</td><td>1</td> <td>1</td> </tr> <tr> <td>0</td><td>1</td><td>0</td> <td>2</td> </tr> <tr> <td>0</td><td>1</td><td>1</td> <td>3</td> </tr> <tr> <td>1</td><td>0</td><td>0</td> <td>4</td> </tr> <tr> <td>1</td><td>0</td><td>1</td> <td>5</td> </tr> <tr> <td>1</td><td>1</td><td>0</td> <td>6</td> </tr> <tr> <td>1</td><td>1</td><td>1</td> <td>7</td> </tr> </tbody> </table>	tCOH [10:8]			MCLK	0	0	0	0	0	0	1	1	0	1	0	2	0	1	1	3	1	0	0	4	1	0	1	5	1	1	0	6	1	1	1	7																																																						
tCOH [10:8]			MCLK																																																																																									
0	0	0	0																																																																																									
0	0	1	1																																																																																									
0	1	0	2																																																																																									
0	1	1	3																																																																																									
1	0	0	4																																																																																									
1	0	1	5																																																																																									
1	1	0	6																																																																																									
1	1	1	7																																																																																									

W90P710CD/W90P710CDG



Continued.

BITS	DESCRIPTION																																						
[7:5]	tACS	<p>Address set-up before nECS for external I/O bank 0~3</p> <table border="1" data-bbox="699 499 1248 821"> <thead> <tr> <th colspan="3">tACS [7:5]</th> <th>MCLK</th> </tr> </thead> <tbody> <tr><td>0</td><td>0</td><td>0</td><td>0</td></tr> <tr><td>0</td><td>0</td><td>1</td><td>1</td></tr> <tr><td>0</td><td>1</td><td>0</td><td>2</td></tr> <tr><td>0</td><td>1</td><td>1</td><td>3</td></tr> <tr><td>1</td><td>0</td><td>0</td><td>4</td></tr> <tr><td>1</td><td>0</td><td>1</td><td>5</td></tr> <tr><td>1</td><td>1</td><td>0</td><td>6</td></tr> <tr><td>1</td><td>1</td><td>1</td><td>7</td></tr> </tbody> </table>		tACS [7:5]			MCLK	0	0	0	0	0	0	1	1	0	1	0	2	0	1	1	3	1	0	0	4	1	0	1	5	1	1	0	6	1	1	1	7
tACS [7:5]			MCLK																																				
0	0	0	0																																				
0	0	1	1																																				
0	1	0	2																																				
0	1	1	3																																				
1	0	0	4																																				
1	0	1	5																																				
1	1	0	6																																				
1	1	1	7																																				
[4:2]	tCOS	<p>Chip selection set-up time of external I/O bank 0~3</p> <p>When ROM/Flash memory bank is configured, the access to its bank stretches chip selection time before the nOE or new signal is activated.</p> <table border="1" data-bbox="699 1016 1248 1337"> <thead> <tr> <th colspan="3">tCOS [4:2]</th> <th>MCLK</th> </tr> </thead> <tbody> <tr><td>0</td><td>0</td><td>0</td><td>0</td></tr> <tr><td>0</td><td>0</td><td>1</td><td>1</td></tr> <tr><td>0</td><td>1</td><td>0</td><td>2</td></tr> <tr><td>0</td><td>1</td><td>1</td><td>3</td></tr> <tr><td>1</td><td>0</td><td>0</td><td>4</td></tr> <tr><td>1</td><td>0</td><td>1</td><td>5</td></tr> <tr><td>1</td><td>1</td><td>0</td><td>6</td></tr> <tr><td>1</td><td>1</td><td>1</td><td>7</td></tr> </tbody> </table>		tCOS [4:2]			MCLK	0	0	0	0	0	0	1	1	0	1	0	2	0	1	1	3	1	0	0	4	1	0	1	5	1	1	0	6	1	1	1	7
tCOS [4:2]			MCLK																																				
0	0	0	0																																				
0	0	1	1																																				
0	1	0	2																																				
0	1	1	3																																				
1	0	0	4																																				
1	0	1	5																																				
1	1	0	6																																				
1	1	1	7																																				
[1:0]	DBWD	<p>Programmable data bus width for external I/O bank 0~3</p> <table border="1" data-bbox="696 1478 1245 1659"> <thead> <tr> <th colspan="2">DBWD [1:0]</th> <th>Width of Data Bus</th> </tr> </thead> <tbody> <tr><td>0</td><td>0</td><td>Disable bus</td></tr> <tr><td>0</td><td>1</td><td>8-bit</td></tr> <tr><td>1</td><td>0</td><td>16-bit</td></tr> <tr><td>1</td><td>1</td><td>32-bit</td></tr> </tbody> </table>		DBWD [1:0]		Width of Data Bus	0	0	Disable bus	0	1	8-bit	1	0	16-bit	1	1	32-bit																					
DBWD [1:0]		Width of Data Bus																																					
0	0	Disable bus																																					
0	1	8-bit																																					
1	0	16-bit																																					
1	1	32-bit																																					

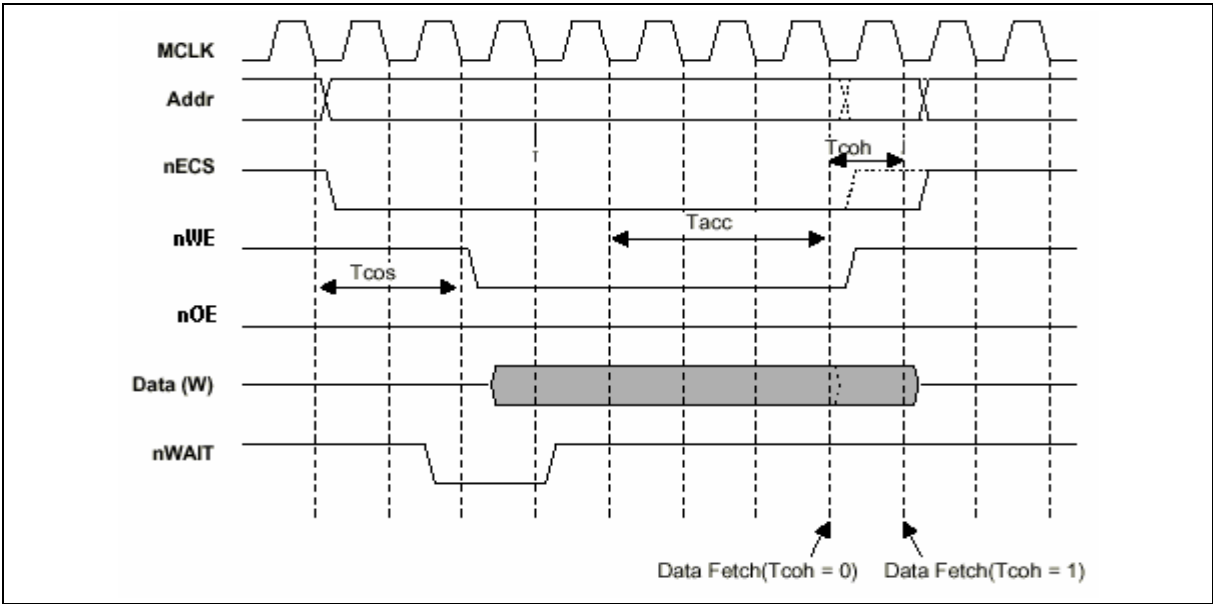

Fig 6.3.6 External I/O write operation timing

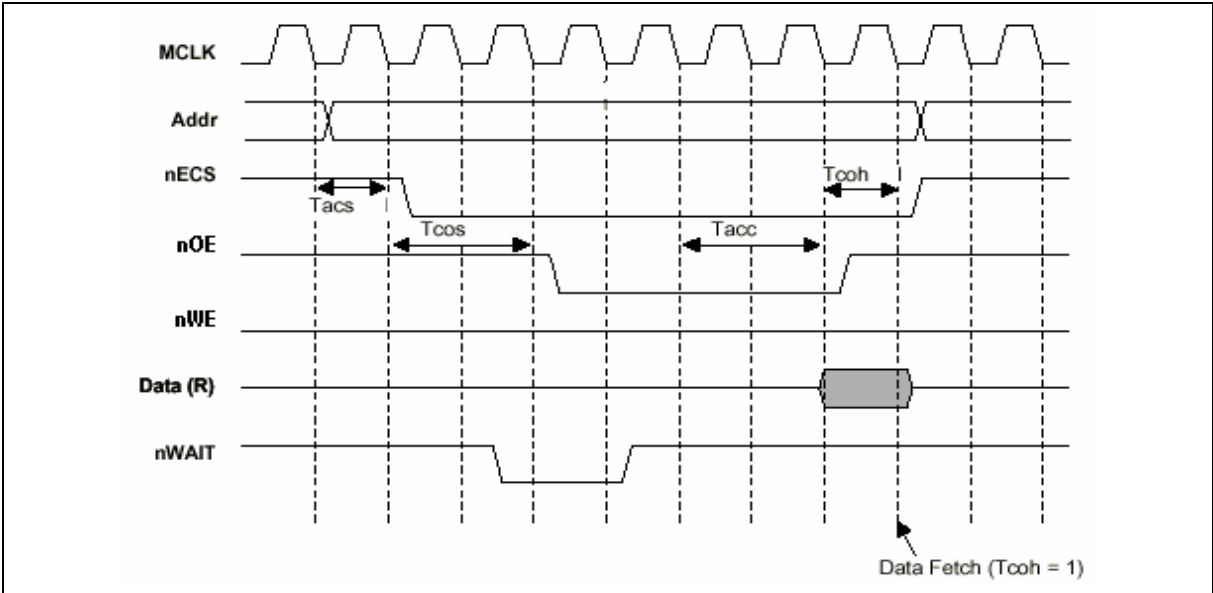

Fig 6.3.7 External I/O read operation timing

W90P710CD/W90P710CDG

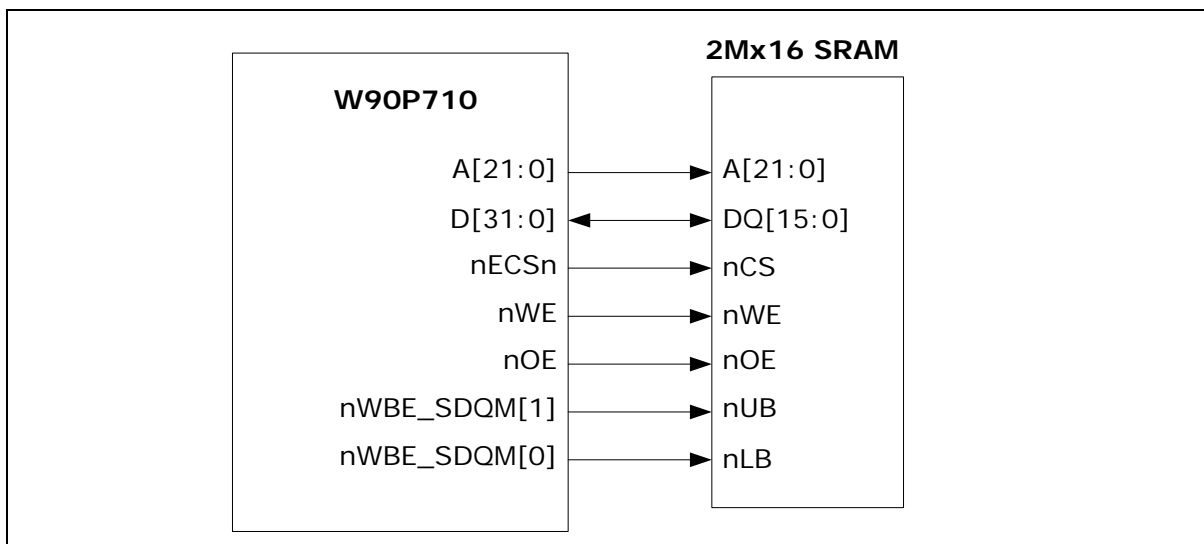

Fig. 6.3.8 External IO bank with 16-bit SRAM

Clock Skew Control Register (CKSKEW)

REGISTER	ADDRESS	R/W	DESCRIPTION	RESET VALUE
CKSKEW	0xFFFF0_1F00	R/W	Clock skew control register	0xXXXX_0018

31	30	29	28	27	26	25	24
DLH_CLK_REF							
23	22	21	20	19	18	17	16
DLH_CLK_REF							
15	14	13	12	11	10	9	8
RESERVED							SWPON
7	6	5	4	3	2	1	0
DLH_CLK_SKEW				MCLK_O_D			

W90P710CD/W90P710CDG



BITS		DESCRIPTION																																																																																										
[31:16]	DLH_CLK_REF	<p>Latch DLH_CLK clock tree by HCLK positive edge</p> <p>SDRAM MCLK is generated by inserting a delay (XOR2) chain on the HCLK positive or negative edge to adjust for MCLK skew. So software can read these bits and explore the MCLK and HCLK relationship, [31:24] is used for the positive edge and [23:16] is for the negative edge.</p>																																																																																										
[15:9]	RESERVED	-																																																																																										
[8]	SWPON	<p>SDRAM Software Initialization</p> <p>Setting this bit to "1" will issue an SDRAM power on default setting command sequence like system power on, this bit is automatically cleared by the hardware after initialization.</p>																																																																																										
[7:4]	DLH_CLK_SKEW	<p>Data latch Clock Skew Adjustment</p> <p>Due to PC board loading or too many devices connecting to external addresses and data buses, SDRAM may not work correctly at higher frequencies (usually, > 80MHz) software can control MCLK_O_D[3:0] to adjust address and data bus to adjust setup/hold time.</p> <table border="1" style="width: 100%; border-collapse: collapse; text-align: center;"> <thead> <tr> <th colspan="4">DLH_CLK_SKEW[7:4]</th> <th>Gate Delay</th> <th colspan="4">DLH_CLK_SKEW[7:4]</th> <th>Gate Delay</th> </tr> </thead> <tbody> <tr> <td>0</td><td>0</td><td>0</td><td>0</td> <td>P-0</td> <td>1</td><td>0</td><td>0</td><td>0</td> <td>N-0</td> </tr> <tr> <td>0</td><td>0</td><td>0</td><td>1</td> <td>P-1</td> <td>1</td><td>0</td><td>0</td><td>1</td> <td>N-1</td> </tr> <tr> <td>0</td><td>0</td><td>1</td><td>0</td> <td>P-2</td> <td>1</td><td>0</td><td>1</td><td>0</td> <td>N-2</td> </tr> <tr> <td>0</td><td>0</td><td>1</td><td>1</td> <td>P-3</td> <td>1</td><td>0</td><td>1</td><td>1</td> <td>N-3</td> </tr> <tr> <td>0</td><td>1</td><td>0</td><td>0</td> <td>P-4</td> <td>1</td><td>1</td><td>0</td><td>0</td> <td>N-4</td> </tr> <tr> <td>0</td><td>1</td><td>0</td><td>1</td> <td>P-5</td> <td>1</td><td>1</td><td>0</td><td>1</td> <td>N-5</td> </tr> <tr> <td>0</td><td>1</td><td>1</td><td>0</td> <td>P-6</td> <td>1</td><td>1</td><td>1</td><td>0</td> <td>N-6</td> </tr> <tr> <td>0</td><td>1</td><td>1</td><td>1</td> <td>P-7</td> <td>1</td><td>1</td><td>1</td><td>1</td> <td>N-7</td> </tr> </tbody> </table> <p>NOTE: P-x means Data latched Clock shift "X" gates delays by referring to the MCLKO positive edge, N-x means Data latched Clock shift "X" gates delays by referring to the MCLKO negative edge.</p>	DLH_CLK_SKEW[7:4]				Gate Delay	DLH_CLK_SKEW[7:4]				Gate Delay	0	0	0	0	P-0	1	0	0	0	N-0	0	0	0	1	P-1	1	0	0	1	N-1	0	0	1	0	P-2	1	0	1	0	N-2	0	0	1	1	P-3	1	0	1	1	N-3	0	1	0	0	P-4	1	1	0	0	N-4	0	1	0	1	P-5	1	1	0	1	N-5	0	1	1	0	P-6	1	1	1	0	N-6	0	1	1	1	P-7	1	1	1	1	N-7
DLH_CLK_SKEW[7:4]				Gate Delay	DLH_CLK_SKEW[7:4]				Gate Delay																																																																																			
0	0	0	0	P-0	1	0	0	0	N-0																																																																																			
0	0	0	1	P-1	1	0	0	1	N-1																																																																																			
0	0	1	0	P-2	1	0	1	0	N-2																																																																																			
0	0	1	1	P-3	1	0	1	1	N-3																																																																																			
0	1	0	0	P-4	1	1	0	0	N-4																																																																																			
0	1	0	1	P-5	1	1	0	1	N-5																																																																																			
0	1	1	0	P-6	1	1	1	0	N-6																																																																																			
0	1	1	1	P-7	1	1	1	1	N-7																																																																																			

W90P710CD/W90P710CDG



Continued.

BITS	DESCRIPTION									
[3:0]	MCLK output delay adjustment									
	MCLK_O_D [3:0]				Gate Delay	MCLK_O_D [3:0]				Gate Delay
	0	0	0	0	P-0	1	0	0	0	N-0
	0	0	0	1	P-1	1	0	0	1	N-1
	0	0	1	0	P-2	1	0	1	0	N-2
	0	0	1	1	P-3	1	0	1	1	N-3
	0	1	0	0	P-4	1	1	0	0	N-4
	0	1	0	1	P-5	1	1	0	1	N-5
	0	1	1	0	P-6	1	1	1	0	N-6
	0	1	1	1	P-7	1	1	1	1	N-7
<p>NOTE: "P-x" means MCLKO shift "X" gates delays by referring to the HCLK positive edge, "N-x" means MCLKO shift "X" gates delays by referring to the HCLK negative edge. MCLK is the output pin of MCLKO, which is an internal signal on chip.</p>										

W90P710CD/W90P710CDG



6.4 Cache Controller

W90P710 incorporates a 4KB Instruction cache, 4KB Data cache and an 8-word write buffer. The I-Cache and D-Cache have similar organization except the cache size. To raise the cache-hit ratio, these two caches are configured two-way set associative addressing. Each cache has four words cache line size. When a miss occurs, four words must be fetched consecutively from external memory. The replacement algorithm is a LRU (Least Recently Used).

If disabling the I-Cache / D-Cache, these cache memories can be treated as On-Chip RAM. W90P710 also provides a write buffer to improve system performance. The write buffer can buffer up to eight words of data.

6.4.1 On-Chip RAM

If I-Cache or D-Cache is disabled, it can serve as On-Chip RAM. If D-Cache is disabled, there is a 4KB On-Chip RAM, its start address is 0xFFE01000. If I-Cache is disabled, there has 4KB On-Chip RAM and the start address of this RAM is 0xFFE00000. If both the I-Cache and D-Cache are disabled, it has 8KB On-Chip RAM starting from 0xFFE00000.

The size of On-Chip RAM is depended on the I-Cache and D-Cache enable bits **ICAEN**, **DCAEN** in Cache Control Register (CAHCON).

Table6.4.1 The size and start address of On-Chip RAM

ICAEN	DCAEN	ON-CHIP RAM	
		SIZE	START ADDRESS
0	0	8KB	0xFFE0_0000
0	1	4KB	0xFFE0_0000
1	0	4KB	0xFFE0.1000
1	1	Unavailable	

6.4.2 Non-Cacheable Area

Although the cache affects the entire 2GB system memory, it is sometimes necessary to define non-cacheable areas when the consistency of data stored in memory and the cache must be ensured. To support this, W90P710 provides a non-cacheable area control bit in address field A[31].

If A[31] in the ROM/FLASH, SDRAM, or external I/O bank's access address is "0", then the accessed data is cacheable. If the A [31] value is "1", the accessed data is non-cacheable.



6.4.3 Instruction Cache

The Instruction cache (I-cache) is a 4K bytes two-way set associative cache. The cache organization is 128 sets, two lines per set, and four words per line. Cache lines are aligned on 4-word boundaries in memory. The cache access cycle begins with an instruction request from the instruction unit in the core. In the case of a cache hit, the instruction is delivered to the instruction unit. In case of a cache miss, the cache initiates a burst read cycle on the internal bus with the address of the requested instruction. The first word received from the bus is the requested instruction. The cache forwards this instruction to the instruction unit of the core as soon as it is received from the internal bus. A cache line is then selected to receive the data that will be coming from the bus. A least recently used (LRU) replacement algorithm is used to select a line when no empty lines are available. When I-Cache is disabled, the cache memory is served as 4KB On-chip RAM. The I-Cache is always disabled on reset.

The following is a list of the instruction cache features:

- 4K bytes instruction cache
- Two-way set associative
- Four words in a cache line
- LRU replacement policy
- Lockable on a per-line basis
- Critical word first, burst access

Instruction Cache Operation

On an instruction fetch, bits 10-4 of the instruction's address point into the cache to retrieve the tags and data of one set. The tags are then compared against bits 30-11 of the instruction's address. If a match is found and the matched entry is valid, then it is a cache hit. If neither tags match or the matched tag is invalid, it is a cache miss.

Instruction Cache Hit

In case of a cache hit, bits 3-2 of the instruction address is used to select one word from the cache line with matching tags. The instruction is immediately transferred to the core instruction unit.

Instruction Cache Miss

On an instruction cache miss, the address of the missed instruction is driven on the internal bus with a 4-word burst transfer read request. A cache line is then selected to receive the data that will be coming from the bus. The selection algorithm gives first priority to invalid lines. If neither of the two lines in the selected set is invalid, then the least recently used line is selected for replacement. Locked lines are never replaced. The transfer begins with the word requested by the instruction unit (critical word first), followed by the remaining words of the line, then by the word at the beginning of the lines (wraparound).

Instruction Cache Flushing

W90P710 does not support external memory snooping. Therefore, if self-modifying code is written, the instructions in the I-Cache may become invalid. The entire I-Cache can be flushed by software in one operation, or can be flushed one line at a time by setting either **CAHCON** register bit **FLHS** or **ICAH** register bit **FLHA**. As flushing the cache line, the "V" bit of the line is cleared to "0". The I-Cache is automatically flushed during reset.



Instruction Cache Load and Lock

W90P710 supports a cache-locking feature that can be used to lock critical sections of code into I-Cache to guarantee quick access. Lockdown can be performed with a granularity of one cache line. The smallest space that can be locked down is 4 words. After a line is locked, it operates as a regular instruction SRAM. Locked lines are not replaced during cache-misses and are not affected by flush-per-line commands.

To load and lock instructions, see the following procedure:

1. Write the start address of the instructions to be locked into **CAHADR** register.
2. Set **LDLK** and **ICAH** bits in the **CAHCON** register.
3. Increase the address by 16 and write into **CAHADR** register.
4. Set **LDLK** and **ICAH** bits in the **CAHCON** register.
5. Repeat steps 3 and 4 until the desired instructions are all locked.

When using the I-Cache load and lock command the following should be taken into consideration:

- Programs executing load and lock operations should be held in non-cacheable memory.
- The cache should be enabled and interrupts should be disabled.
- Software must flush the cache before executing load and lock to ensure that the code to be locked down is not already in the cache.

Instruction Cache Unlock

The unlock operation is used to unlock previously locked cache lines. After unlocking, the "L" bit of the line is cleared to "0". W90P710 has two unlock commands, unlock line and unlock all.

The unlock line operation is performed on a cache line. In case the line is found in the cache, it is unlocked and operates as a regular valid cache line. In case the line is not found in the cache, nothing is executed and the command terminates without raising an exception. To unlock one line, the following unlock line sequence should be followed:

1. Write the address of the line to be unlocked into the **CAHADR** Register.
2. Set the **ULKS** and **ICAH** bits in the **CAHCON** register.

The unlock all operation is used to unlock the whole I-Cache. This operation is performed on all cache lines. In case a line is locked, it is unlocked and starts to operate as regular valid cache line. In case a line is not locked or if it is invalid, no operation is performed. To unlock the whole cache, set the **ULKA** and **ICAH** bits.



6.4.4 Data Cache

W90P710 data cache (D-Cache) is a 4KB two-way set associative cache. The cache organization is 128 sets, two lines per set, and four words per line. Cache lines are aligned on 4-word boundaries in memory. The cache is designed for **buffer write-through** mode of operation and a least recently used (LRU) replacement algorithm is used to select a line when no empty lines are available.

When D-Cache is disabled, the cache memory is served as 4KB On-chip RAM.

The D-Cache is always disabled on reset.

The following is a list of the data cache features:

- 4K bytes data cache
- Two-way set associative
- Four words in a cache line
- LRU replacement policy
- Lockable on a per-line basis
- Critical word first, burst access
- Buffer Write-through mode
- 8 words write buffer
- Drain write buffer

Data Cache Operation

On a data fetch, bits 10-4 of the data's address point into the cache to retrieve the tags and data of one set. The tags from both are then compared against bits 30-11 of the data's address. If a match is found and the matched entry is valid, then it is a cache hit. If neither tags match or the matched tag is invalid, it is a cache miss.

Data Cache Read

Read Hit: On a cache hit, the requested word is immediately transferred to the core.

Read Miss: A line in the cache is selected to hold the data to be fetched from memory. The selection algorithm gives first priority to idate lines in the selected set is invalid, then one of the lines is selected by the LRU algorithm to replace. The transfer begins with the aligned word containing the missed data (critical word first), followed bnvaid lines. If both lines are invalid the way zero line is selected first. If neither of the two candiy the remaining word in the line, then by the word at the beginning of the line (wraparound). As the missed word is received from the bus, it is delivered directly to the core.

Data Cache Write

In buffer write-through mode, store operations always update memory. The buffer write-through mode is used when external memory and internal cache images must always agree.

W90P710CD/W90P710CDG



Write Hit: Data is written into both the cache and write buffer. The processor then continues to access the cache, while the cache controller simultaneously downloads the contents of the write buffer to main memory. This reduces the effective write memory cycle time from the time required for a main memory cycle to the cycle time of the high-speed cache.

Write Miss: Data is only written into the write buffer, and not to the cache (write no allocate).

Data Cache Flushing

W90P710 allows the data cache to be flushed under software control. The data cache may be invalidated by writing flush line (**FLHS**) or flush all (**FLHA**) commands to the **CAHCON** register. Flushing the entire D-Cache also flushes any locked down code. As flushing the data cache, the "V" bit of the line is cleared to "0". The D-cache is automatically flushed during reset.

Data Cache Load and Lock

W90P710 supports a cache-locking feature that can be used to lock critical sections of data into D-Cache to guarantee quick access. Lockdown can be performed with a granularity of one cache line. The smallest space, which can be locked down, is 4 words. After a line is locked, it operates as a regular SRAM instruction. The locked lines are not replaced during misses and are not affected by flush-per-line commands.

To load and lock data, see the following procedure:

1. Write the start address of the data to be locked into **CAHADR** register.
2. Set **LDLK** and **DCAH** bits in the **CAHCON** register.
3. Increase the address by 16 and write into **CAHADR** register.
4. Set **LDLK** and **DCAH** bits in the **CAHCON** register.
5. Repeat steps 3 and 4, until all the desired data are locked.

When using D-Cache load and lock command, the following should be taken into consideration:

- The programs executing load and lock operation should be held in a non-cacheable area of memory.
- The cache should be enabled and interrupts disabled.
- Software must flush the cache before executing load and lock to ensure that the data to be locked down is not already in the cache.

Data Cache Unlock

The unlock operation is used to unlock previously locked cache lines. After unlocking, the "L" bit of the line is cleared to "0". W90P710 has two unlock commands, unlock line and unlock all.

The unlock line operation is performed on a cache line granularity. In case the line is found in the cache, it is unlocked and starts to operate as a regular valid cache line. In case the line is not found in the cache, nothing is executed and the command terminates without raising an exception. To unlock one line the following unlock line sequence should be followed:

1. Write the address of the line to be unlocked into the **CAHADR** Register.
2. Set the **ULKS** and **DCAH** bits in the **CAHCON** register.

W90P710CD/W90P710CDG



The unlock all operation is used to unlock the whole D-Cache. This operation is performed on all cache lines. In case a line is locked, it is unlocked and functions as a regular valid cache line. In case a line is not locked or if it is invalid, no operation is performed. To unlock the whole cache, set the **ULKA** and **DCAH** bits.

6.4.5 Write Buffer

W90P710 provides a write buffer to improve system performance. The write buffer can store up to eight words of data. The write buffer may be enabled or be disabled via the **WRBEN** bit in the **CAHCNF** register; the buffer is disabled and flushed on reset.

Drain write buffer

This command forces data in the write buffer to be written to external main memory. This operation is useful in real time applications where the processor needs to be sure that a write to a peripheral is complete before program execution continues.

To perform this command, you can set the **DRWB** and **DCAH** bits in **CAHCON** register.

6.4.6 Cache Control Registers Map

REGISTER	ADDRESS	R/W	DESCRIPTION	RESET VALUE
CAHCNF	0xFFFF0_2000	R/W	Cache configuration register	0x0000_0000
CAHCON	0xFFFF0_2004	R/W	Cache control register	0x0000_0000
CAHADR	0xFFFF0_2008	R/W	Cache address register	0x0000_0000
CTEST0	0xFFFF6_0000	R/W	Cache test register 0	0x0000_0000
CTEST1	0xFFFF6_0004	R	Cache test register 1	0x0000_0000

Configuration Register (CAHCNF)

Cache controller has a configuration register to enable or disable the I-Cache, D-Cache, and Write buffer.

REGISTER	ADDRESS	R/W	DESCRIPTION	RESET VALUE
CAHCNF	0xFFFF0_2000	R/W	Cache configuration register	0x0000_0000

31	30	29	28	27	26	25	24
RESERVED							
23	22	21	20	19	18	17	16
RESERVED							
15	14	13	12	11	10	9	8
RESERVED							
7	6	5	4	3	2	1	0
RESERVED					WRBEN	DCAEN	ICAEN



BITS	DESCRIPTION	
[31:3]	RESERVED	-
[2]	WRBEN	Write buffer enable Write buffer is disabled after reset. 1 = Enable write buffer 0 = Disable write buffer
[1]	DCAEN	D-Cache enable D-Cache is disabled after reset. 1 = Enable D-cache 0 = Disable D-cache
[0]	ICAEN	I-Cache enable I-Cache is disabled after reset. 1 = Enable I-cache 0 = Disable I-cache

Control Register (CAHCON)

Cache controller supports one Control register used to control the following operations.

- Flush I-Cache and D-Cache
- Load and lock I-Cache and D-Cache
- Unlock I-Cache and D-Cache
- Drain write buffer

These commands set **CAHCON** register bits, and are auto-clearing. I.e. after execution, the set bit automatically returns to "0".

REGISTER	ADDRESS	R/W	DESCRIPTION	RESET VALUE
CAHCON	0xFFFF0_2004	R/W	Cache control register	0x0000_0000

31	30	29	28	27	26	25	24
RESERVED							
23	22	21	20	19	18	17	16
RESERVED							
15	14	13	12	11	10	9	8
RESERVED							
7	6	5	4	3	2	1	0
DRWB	ULKS	ULKA	LDLK	FLHS	FLHA	DCAH	ICAH



BITS	DESCRIPTION	
[31:8]	RESERVED	-
[7]	DRWB	Drain write buffer Forces write buffer data to be written to external main memory.
[6]	ULKS	Unlock I-Cache/D-Cache single line Unlocks the I-Cache/D-Cache per line. Both WAY and ADDR bits in CAHADR register must be specified.
[5]	ULKA	Unlock I-Cache/D-Cache entirely Unlocks the entire I-Cache/D-Cache, the lock bit "L" will be cleared to 0.
[4]	LDLK	Load and Lock I-Cache/D-Cache Loads the instruction or data from external main memory and locks into cache. Both WAY and ADDR bits in CAHADR register must be specified.
[3]	FLHS	Flush I-Cache/D-Cache single line Flushes the entire I-Cache/D-Cache per line. Both WAY and ADDR bits in CAHADR register must be specified.
[2]	FLHA	Flush I-Cache/D-Cache entirely To flush the entire I-Cache/D-Cache, also flushes any locked-down code. If the I-Cache/D-Cache contains locked down code, the programmer must flush lines individually
[1]	DCAH	D-Cache selected When set to "1", the command is executed with D-Cache.
[0]	ICAH	I-Cache selected When set to "1", the command is executed with I-Cache.

NOTE: When using the **FLHA** or **ULKA** command, you can set **both ICAH** and **DCAH** bits to flush or lock the entire I-Cache **and** D-Cache. But, **FLHS** and **ULKS** commands can only be executed with one cache line specified by the **CAHADR** register in I-Cache **or** D-Cache at a time. If you set **both ICAH** and **DCAH** bits, and set **FLHS** or **ULKS** command bits, it will be treated as invalid, and the command terminates without raising an exception.

The **Drain Write Buffer** operation is only for D-Cache. To perform this operation, you must set **DRWB** and **DCAH** bits. If the **ICAH** bit is set when using the **DRWB** command, it will be treated as invalid, and the command terminates without raising an exception.

Address Register (CAHADR)

W90P710 Cache Controller supports one address register. This address register is used with the command set in the control register (**CAHCON**) by specifying instruction/data address.

W90P710CD/W90P710CDG



REGISTER	ADDRESS	R/W	DESCRIPTION	RESET VALUE
CAHADR	0xFFFF0_2008	R/W	Cache address register	0x0000_0000

31	30	29	28	27	26	25	24
WAY		ADDR					
23	22	21	20	19	18	17	16
ADDR							
15	14	13	12	11	10	9	8
ADDR							
7	6	5	4	3	2	1	0
ADDR							

BITS	DESCRIPTION	
[31]	WAY	Way selection 0 = Way0 is selected 1 = Way1 is selected
[30:0]	ADDR	The absolute address of instruction or data

Cache Test Register 0 (CTEST0)

Cache test control register enables/disables cache and tag RAM testing. In addition, this register controls the built-in self-test (BIST) SRAM function.

REGISTER	ADDRESS	R/W	DESCRIPTION	RESET VALUE
CTEST0	0xFFF6_0000	R/W	Cache test register 0	0x0000_0000

31	30	29	28	27	26	25	24
RESERVED							
23	22	21	20	19	18	17	16
RESERVED							
15	14	13	12	11	10	9	8
BISTEN	RESERVED			BST_GP3	BST_GP2	BST_GP1	BST_GP0
7	6	5	4	3	2	1	0
RESERVED							CATEST

W90P710CD/W90P710CDG



BITS	DESCRIPTION	
[31:16]	RESERVED	-
[15]	BISTEN	BIST mode enable When set to "1", BIST mode will be enabled and the selected memory groups begins BIST testing.
[14:12]	RESERVED	-
[11]	BIST_GP3	Memory group 3 is selected for BIST testing When set to "1", memory group 3, including data cache tag ram way 0 and way 1, are selected for BIST testing.
[10]	BIST_GP2	Memory group 2 is selected for BIST testing When set to "1", memory group 2, including program cache tag ram way 0 and way 1, are selected for BIST testing.
[9]	BIST_GP1	Memory group 1 is selected for BIST testing When set to "1", memory group 1, including data cache ram way 0 and way 1, are selected for BIST testing.
[8]	BIST_GP0	Memory group 0 is selected for BIST testing When set to "1", memory group 0, including program cache ram way 0 and way 1, are selected for BIST testing.
[7:0]	RESERVED	-

** Note: The 4 memory groups can be selected and tested simultaneously by BIST.

Cache Test Register 1 (CTEST1)

Cache Test Register that will be read back to provide the status of cache RAM BIST. The current testing status is stored in this register.

REGISTER	ADDRESS	R/W	DESCRIPTION	RESET VALUE
CTEST1	0xFFF6_0004	R	Cache test register 1	0x0000_0000

31	30	29	28	27	26	25	24
FINISH		RESERVED					
23	22	21	20	19	18	17	16
RESERVED							
15	14	13	12	11	10	9	8
RESERVED							
7	6	5	4	3	2	1	0
BFAIL7	BFAIL6	BFAIL5	BFAIL4	BFAIL3	BFAIL2	BFAIL1	BFAIL0

W90P710CD/W90P710CDG



BITS	DESCRIPTION	
[31]	FINISH	BIST completed This bit is "0" initially. After BIST testing is complete, this bit is set to "1". The values of BFAIL0-7 are valid only after FINISH = 1.
[30:8]	RESERVED	-
[7]	BFAIL7	BIST test fail for data cache tag RAM way 1 If this bit equals "1", it indicates the data cache tag ram for way 1 was failed by BIST. "0" means the test was passed.
[6]	BFAIL6	BIST test fail for data cache tag RAM way 0 If this bit equals "1", it indicates the data cache tag ram for way 0 was failed by BIST. "0" means the test was passed.
[5]	BFAIL5	BIST test fail for instruction cache tag RAM way 1 If this bit equals "1", it indicates the instruction cache tag ram for way 1 was failed by BIST. "0" means the test was passed.
[4]	BFAIL4	BIST test fail for instruction cache tag RAM way 0 If this bit equals to "1", it indicates the instruction cache tag ram for way 0 was failed by BIST. "0" means the test was passed.
[3]	BFAIL3	BIST test fail for data cache RAM way 1 If this bit equals to "1", it indicates the data cache ram for way 1 was failed by BIST. "0" means the test was passed.
[2]	BFAIL2	BIST test fail for data cache RAM way 0 If this bit equals "1", it indicates the data cache ram for way 0 was failed by BIST. "0" means the test was passed.
[1]	BFAIL1	BIST test fail for instruction cache RAM way 1 If this bit equals to "1", it indicates the instruction cache ram for way 1 was failed by BIST. "0" means the test was passed.
[0]	BFAIL0	BIST test fail for instruction cache RAM way 0 If this bit equals to "1", it indicates the instruction cache ram for way 0 was failed by BIST. "0" means the test was passed.



6.5 Ethernet MAC Controller

Overview

W90P710 provides an Ethernet MAC Controller (EMC) for LAN application. This EMC has a DMA controller, transmit FIFO, and receive FIFO.

The Ethernet MAC controller consists of an IEEE 802.3/Ethernet protocol engine with internal CAM function for Ethernet MAC address recognition, Transmit-FIFO, Receive-FIFO, TX/RX state machine controller and status controller. The EMC only supports RMII (Reduced MII) interface to connect with PHY operating on 50MHz REF_CLK.

Features

- Supports IEEE Std. 802.3 CSMA/CD protocol.
- Supports both half and full duplex for 10M/100M bps operation.
- Supports RMII interface.
- Supports MII Management function.
- Supports pause and remote pause function for flow control.
- Supports long frame (more than 1518 bytes) and short frame (less than 64 bytes) reception.
- Supports 16 entries CAM function for Ethernet MAC address recognition.
- Supports internal loop back mode for diagnostics.
- Supports 256 bytes embedded transmit and receive FIFO.
- Supports DMA function.

6.5.1 EMC Functional Description

MII Management State Machine

The MII management function of EMC is compliant with IEEE 802.3 Std. Through the MII management interface, software can access the control and status registers of the external PHY chip. The two programmable registers MIID (MAC MII Management Data Register) and MIIDA (MAC MII Management Data Control and Address Register) are for MII management functions. Setting the BUSY bit of the MIIDA register triggers the MII management state machine. After the MII management cycle is finished, the BUSY bit is automatically cleared.

Media Access Control (MAC)

The W90P710 MAC function fully meets the requirements defined in the IEEE802.3u specification. The following paragraphs describe the frame structure and data reception and transmission operations.

The transmission data frame sent from the transmit DMA are encapsulated by the MAC before transmitting onto the MII bus. The data sent is assembled with preamble, the start frame delimiter (SFD), the frame check sequence and padding to ensure the 64-byte minimum frame size and CRC sequence. The outgoing frame format is as follows:

W90P710CD/W90P710CDG



10101010 --- 10101010	10101011	d0	d1	d2	-	dn	Padding	CRC31	CRC30	---	CRC0
-----------------------	----------	----	----	----	---	----	---------	-------	-------	-----	------

As mentioned by the above format, the preamble is a consecutive 7-byte long with the pattern “10101010” and the SFD is a one byte 10101011 data. The padding data will be all 0 value if the sent data frame is less than 64 bytes. The padding disable function specified in the bit P of the transmit descriptor is used to control if the MAC needs to pad data at the end of frame data or not when the transmitted data frame is less than 64 bytes. The padding data will not be appended if the padding disable bit is set to be high. The bits CRC0 ... CRC31 are the 32 bits cyclic redundancy check (CRC) sequence. The CRC encoding is defined by the following polynomial specified by the IEEE802.3. This 32 bits CRC appending function will be disabled if the Inhibit CRC of the transmission descriptor is set to high.

The MAC also performs many other transmission functions specified by IEEE802.3, including the inter-frame spacing function, collision detection, collision enforcement, collision back-off and retransmission. The collision back-off timer is a function of the integer slot time, 512 bit times. The number of slot times to delay between the current transmission attempt and the next attempt is determined by a uniformly distributed random integer algorithm specified by IEEE802.3. The MAC performs the receive functions specified by IEEE 802.3 including the address recognition function, the frame check sequence validation, the frame disassembly, framing and collision filtering.

EMC Descriptors

A linked-list data structure called a descriptor is used to keep the control, status and data information of each frame. Through the descriptor, CPU and EMC exchange the information for frame reception and transmission.

Two different descriptors are defined in W90P710. One named as Rx descriptor for frame reception and the other names as Tx descriptor for frame transmission. Each Rx descriptor consists of four words. There is much information stored in these descriptors, and details are as follows:

6.5.1.1 Rx Buffer Descriptor

3	3	2	1	1	
1	0	9	6	5	0
O	Rx Status			Receive Byte Count	
Receive Buffer Starting Address					BO
Reserved					
Next Rx Descriptor Starting Address					



Rx Descriptor Word 0

31	30	29	28	27	26	25	24
Owner		Reserved					
23	22	21	20	19	18	17	16
Reserved	RP	ALIE	RXGD	PTLE	Reserved	CRCE	RXINTR
15	14	13	12	11	10	9	8
RBC							
7	6	5	4	3	2	1	0
RBC							

Owner [31:30]: Ownership

The ownership field defines if the CPU or EMC is the owner of each Rx descriptor. Only the owner has write access to the Rx descriptor. Otherwise the descriptor is read-only.

00: The owner is CPU

01: Undefined

10: The owner is EMC

11: Undefined

If the O=2'b10 indicates the EMC RxDMA is the owner of Rx descriptor and the Rx descriptor is available for frame reception. After the frame reception completed, if the frame needs NAT translation, EMC RxDMA modifies the ownership field to 2'b11. Otherwise, the ownership field is modified to 2'b00.

If O=2'b00 indicates the CPU is the owner of Rx descriptor, after the CPU completes processing the frame it modifies the ownership field to 2'b10 and releases the Rx descriptor to EMC RxDMA.

Rx Status [29:16]: Receive Status

This field stores the status for frame reception. All status bits are updated by the EMC. In the receive status, bits 29 to 23 are undefined and reserved for the future.

RP [22]: Runt Packet

The RP indicates the frame stored in the data buffer pointed to by the Rx descriptor is a short frame (frame length is less than 64 bytes).

1'b0: Frame is not a short frame.

1'b1: Frame is a short frame.

ALIE [21]: Alignment Error

The ALIE indicates the frame stored in the data buffer pointed to by the Rx descriptor is not a multiple of byte.



1'b0: Frame is a multiple of byte.

1'b1: Frame is not a multiple of byte.

RXGD [20]: Frame Reception Complete

The RXGD indicates the frame reception has completed and stored in the data buffer pointed by the Rx descriptor.

1'b0: Frame reception is incomplete.

1'b1: Frame reception complete.

PTLE [19]: Packet Too Long

The PTLE indicates the frame stored in the data buffer pointed to by the Rx descriptor is a long frame (frame length is greater than 1518 bytes).

1'b0: The frame is not a long frame.

1'b1: The frame is a long frame.

CRCE [17]: CRC Error

CRCE indicates the frame stored in the data buffer pointed to by the Rx descriptor caused a CRC error.

1'b0: No error.

1'b1: Frame caused CRC error.

RXINTR [16]: Receive Interrupt

The RXINTR indicates the frame stored in the data buffer pointed by Rx descriptor caused an interrupt.

1'b0: No interrupt.

1'b1: Frame caused an interrupt.

RBC [15:0]: Receive Byte Count

RBC indicates the byte count of the frame stored in the data buffer pointed to by Rx descriptor. The four-byte CRC field is also included in the receive byte count. But if the SPCRC of register MCMR is enabled, the four-byte CRC field is excluded from the receive byte count.

Rx Descriptor Word 1

31	30	29	28	27	26	25	24
RXBSA							
23	22	21	20	19	18	17	16
RXBSA							
15	14	13	12	11	10	9	8
RXBSA							
7	6	5	4	3	2	1	0

W90P710CD/W90P710CDG



RXBSA	BO
-------	----

RXBSA [31:2]: Receive Buffer Starting Address

RXBSA indicates the starting address of the receive frame buffer. RXBSA is bit 31 to 2 of the memory address. In other words, the starting address of the receive frame buffer is always located on a word boundary.

BO [1:0]: Byte Offset

BO indicates the byte offset from RXBSA where the received frame starts. If BO is 2'b01, the starting address where the received frame begins is RXBSA+2'b01, and so on.

Rx Descriptor Word 2

31	30	29	28	27	26	25	24
Reserved							
23	22	21	20	19	18	17	16
Reserved							
15	14	13	12	11	10	9	8
Reserved							
7	6	5	4	3	2	1	0
Reserved							

Rx descriptor word 2 stores obsolete information for MAC translation. Therefore, these information bits are undefined and should be ignored.

Rx Descriptor Word 3

31	30	29	28	27	26	25	24
NRXDSA							
23	22	21	20	19	18	17	16
NRXDSA							
15	14	13	12	11	10	9	8
NRXDSA							
7	6	5	4	3	2	1	0
NRXDSA							

NRXDSA [31:0]: Next Rx Descriptor Starting Address

W90P710CD/W90P710CDG



Rx descriptor is a link-list data structure. Consequently, NRXDSA is used to store the starting address of the next Rx descriptor. Bits [1:0] are ignored by the EMC. So, all Rx descriptors must be located on a memory address word boundary.

W90P710CD/W90P710CDG



6.5.1.2 Tx Buffer Descriptor

3 3		1 1								
1 0		6 5						3 2 1 0		
O	Reserved							I	C	P
Transmit Buffer Starting Address									BO	
Tx Status					Transmit Byte Count					
Next Tx Descriptor Starting Address										

Tx Descriptor Word 0

31	30	29	28	27	26	25	24
Owner		Reserved					
23	22	21	20	19	18	17	16
Reserved							
15	14	13	12	11	10	9	8
Reserved							
7	6	5	4	3	2	1	0
Reserved					IntEn	CRCApp	PadEn

Owner [31]: Ownership

The ownership field defines which of the CPU or EMC is the owner of each Tx descriptor. Only the owner has right to modify the Tx descriptor, otherwise the Tx descriptor is read-only.

0: The owner is the CPU

1: The owner is the EMC

If O=1'b1 indicates the EMC TxDMA is the owner, and the Tx descriptor is available for frame transmission, then after the frame transmission complete, the EMC TxDMA modifies the ownership field to 1'b0 and returns ownership of the Tx descriptor to the CPU.

If O=1'b0 indicates the CPU is the owner, then after the CPU prepares a new frame for transmission, it modifies the ownership field to 1'b1 and releases the Tx descriptor to EMC TxDMA.

IntEn [2]: Transmit Interrupt Enable

IntEn controls the interrupt trigger circuit after frame transmission complete. If IntEn is enabled, the EMC will trigger interrupt after frame transmission complete. Otherwise, the interrupt is not triggered.

1'b0: Frame transmission interrupt is masked.

1'b1: Frame transmission interrupt is enabled.



CRCApp [1]: CRC Append

The CRCApp control the CRC append during frame transmission. If CRCApp is enabled, the 4-bytes CRC checksum is appended to frame at the end of frame transmission.

1'b0: 4-bytes CRC appending is disabled.

1'b1: 4-bytes CRC appending is enabled.

PadEN [0]: Padding Enable

PadEN control's appending of PAD bits while the length of transmission frame is less than 60 bytes. If PadEN is enabled, the EMC automatically adds the padding.

1'b0: PAD bits appending is disabled.

1'b1: PAD bits appending is enabled.

Tx Descriptor Word 1

31	30	29	28	27	26	25	24
TXBSA							
23	22	21	20	19	18	17	16
TXBSA							
15	14	13	12	11	10	9	8
TXBSA							
7	6	5	4	3	2	1	0
TXBSA						BO	

TXBSA [31:2]: Transmit Buffer Starting Address

TXBSA indicates the starting address of the transmit frame buffer. TXBSA is located at bit 31 to 2 of the memory address. In other words, the starting address of the transmit frame buffer is always located on a word boundary.

BO [1:0]: Byte Offset

BO indicates the byte offset from TXBSA where the transmit frame read begins. If BO is 2'b01, the starting address where the transmit frame read begins is TXBSA+2'b01, and so on.



Tx Descriptor Word 2

31	30	29	28	27	26	25	24
CCNT				Reserved	SQE	PAU	TXHA
23	22	21	20	19	18	17	16
LC	TXABT	NCS	EXDEF	TXCP	Reserved	DEF	TXINTR
15	14	13	12	11	10	9	8
TBC							
7	6	5	4	3	2	1	0
TBC							

CCNT [31:28]: Collision Count

CCNT indicates the how many collisions occurred consecutively during packet transmission. If the packet incurred 16 consecutive collisions during transmission, the CCNT is 4'h0 and bit TXABT is set to 1.

SQE [26]: SQE Error

SQE indicates an SQE error was found at the end of packet transmission on 10Mbps half-duplex mode. The SQE error check is only performed when both EnSQE bits of the MCMDR are enabled and the EMC operates in 10Mbps half-duplex mode.

1'b0: No SQE error found at the end of packet transmission.

1'b1: SQE error found at the end of packet transmission.

PAU [25]: Transmission Paused

PAU INDICATES THE NEXT NORMAL PACKET transmission process is temporally paused because the EMC received a PAUSE control frame, or S/W set bit SDPZ of MCMDR and requests the EMC to transmit a PAUSE control frame out.

1'b0: Next normal packet transmission process will continue.

1'b1: Next normal packet transmission process is paused.

TXHA [24]: Transmission Halted

TXHA indicates the next normal packet transmission process is halted because the bit TXON of MCMDR is disabled in S/W.

1'b0: Next normal packet transmission process will continue.

1'b1: Next normal packet transmission process is halted.



LC [23]: Late Collision

LC indicates the collision occurred outside of the 64-byte collision window. This means that after the 64 bytes of the frame was transmitted, the collision still occurred. The late collision check is only performed when the EMC is operating in half-duplex mode.

1'b0: No collision occurred outside of the 64-byte collision window.

1'b1: Collision occurred outside of 64-byte collision window.

TXABT [22]: Transmission Abort

TXABT indicates the packet incurred 16 consecutive collisions during transmission, and then the transmission process for this packet was aborted. Transmission abort is only available while the EMC is operating in half-duplex mode.

1'b0: Packet didn't incur 16 consecutive collisions during transmission.

1'b1: Packet incurred 16 consecutive collisions during transmission.

NCS [21]: No Carrier Sensed

The NCS indicates the MII I/F signal CRS didn't activate at the start of or during packet transmission. The NCS is only available while the EMC is operating in half-duplex mode.

1'b0: CRS signal activated correctly.

1'b1: CRS signal didn't activate at the start of or during packet transmission.

EXDEF [20]: Defer Exceed

EXDEF indicates the frame waiting for transmission has deferred over 0.32768ms in 100Mbps mode, or 3.2768ms in 10Mbps mode. The deferral exceed check is only performed while the NDEF bit of MCMR is disabled, and the EMC operates in half-duplex mode.

1'b0: Frame waiting for transmission has not deferred over 0.32768ms (100Mbps) or 3.2768ms (10Mbps).

1'b1: Frame waiting for transmission has deferred over 0.32768ms (100Mbps) or 3.2768ms (10Mbps).

TXCP [19]: Transmission Complete

TXCP indicates the packet transmission completed correctly.

1'b0: Packet transmission isn't complete.

1'b1: Packet transmission is complete.

DEF [17]: Transmission Deferred

The DEF indicates the packet transmission has deferred once. The DEF is only available while the EMC operates in half-duplex mode.

1'b0: Packet transmission doesn't defer.

1'b1: Packet transmission has deferred once.



TXINTR [16]: Transmit Interrupt

TXINTR indicates packet transmission caused an interrupt.

1'b0: Packet transmission doesn't cause an interrupt.

1'b1: Packet transmission caused an interrupt.

TBC [15:0]: Transmit Byte Count

TBC indicates the byte count of the frame stored in the data buffer pointed by the Tx descriptor for transmission.

Tx Descriptor Word 3

31	30	29	28	27	26	25	24
NTXDSA							
23	22	21	20	19	18	17	16
NTXDSA							
15	14	13	12	11	10	9	8
NTXDSA							
7	6	5	4	3	2	1	0
NTXDSA							

NTXDSA [31:0]: Next Tx Descriptor Starting Address

The Tx descriptor is a linked-list data structure. Consequently, NTXDSA is used to store the starting address of the next Tx descriptor. Bits [1:0] are ignored by the EMC. So, all Tx descriptors must be located at memory address word boundaries.



6.5.2 EMC Register Mapping

The EMC implements many registers, which are separated into three types: control registers, status registers and diagnostic registers. Control registers are used by S/W to pass control information to the EMC. Status registers are used to store the EMC operating status for S/W. And, the diagnostic registers are used for debugging only.

EMC Registers

REGISTER	ADDRESS	R/W	DESCRIPTION	RESET VALUE
CONTROL REGISTERS (44)				
CAMCMR	0xFFFF0_3000	R/W	CAM Command Register	0x0000_0000
CAMEN	0xFFFF0_3004	R/W	CAM Enable Register	0x0000_0000
CAM0M	0xFFFF0_3008	R/W	CAM0 Most Significant Word Register	0x0000_0000
CAM0L	0xFFFF0_300C	R/W	CAM0 Least Significant Word Register	0x0000_0000
CAM1M	0xFFFF0_3010	R/W	CAM1 Most Significant Word Register	0x0000_0000
CAM1L	0xFFFF0_3014	R/W	CAM1 Least Significant Word Register	0x0000_0000
CAM2M	0xFFFF0_3018	R/W	CAM2 Most Significant Word Register	0x0000_0000
CAM2L	0xFFFF0_301C	R/W	CAM2 Least Significant Word Register	0x0000_0000
CAM3M	0xFFFF0_3020	R/W	CAM3 Most Significant Word Register	0x0000_0000
CAM3L	0xFFFF0_3024	R/W	CAM3 Least Significant Word Register	0x0000_0000
CAM4M	0xFFFF0_3028	R/W	CAM4 Most Significant Word Register	0x0000_0000
CAM4L	0xFFFF0_302C	R/W	CAM4 Least Significant Word Register	0x0000_0000
CAM5M	0xFFFF0_3030	R/W	CAM5 Most Significant Word Register	0x0000_0000
CAM5L	0xFFFF0_3034	R/W	CAM5 Least Significant Word Register	0x0000_0000
CAM6M	0xFFFF0_3038	R/W	CAM6 Most Significant Word Register	0x0000_0000
CAM6L	0xFFFF0_303C	R/W	CAM6 Least Significant Word Register	0x0000_0000
CAM7M	0xFFFF0_3040	R/W	CAM7 Most Significant Word Register	0x0000_0000
CAM7L	0xFFFF0_3044	R/W	CAM7 Least Significant Word Register	0x0000_0000
CAM8M	0xFFFF0_3048	R/W	CAM8 Most Significant Word Register	0x0000_0000
CAM8L	0xFFFF0_304C	R/W	CAM8 Least Significant Word Register	0x0000_0000
CAM9M	0xFFFF0_3050	R/W	CAM9 Most Significant Word Register	0x0000_0000
CAM9L	0xFFFF0_3054	R/W	CAM9 Least Significant Word Register	0x0000_0000
CAM10M	0xFFFF0_3058	R/W	CAM10 Most Significant Word Register	0x0000_0000
CAM10L	0xFFFF0_305C	R/W	CAM10 Least Significant Word Register	0x0000_0000
CAM11M	0xFFFF0_3060	R/W	CAM11 Most Significant Word Register	0x0000_0000
CAM11L	0xFFFF0_3064	R/W	CAM11 Least Significant Word Register	0x0000_0000

W90P710CD/W90P710CDG



Continued.

REGISTER	ADDRESS	R/W	DESCRIPTION	RESET VALUE
CONTROL REGISTERS (44)				
CAM12M	0xFFFF0_3068	R/W	CAM12 Most Significant Word Register	0x0000_0000
CAM12L	0xFFFF0_306C	R/W	CAM12 Least Significant Word Register	0x0000_0000
CAM13M	0xFFFF0_3070	R/W	CAM13 Most Significant Word Register	0x0000_0000
CAM13L	0xFFFF0_3074	R/W	CAM13 Least Significant Word Register	0x0000_0000
CAM14M	0xFFFF0_3078	R/W	CAM14 Most Significant Word Register	0x0000_0000
CAM14L	0xFFFF0_307C	R/W	CAM14 Least Significant Word Register	0x0000_0000
CAM15M	0xFFFF0_3080	R/W	CAM15 Most Significant Word Register	0x0000_0000
CAM15L	0xFFFF0_3084	R/W	CAM15 Least Significant Word Register	0x0000_0000
TXDLSA	0xFFFF0_3088	R/W	Transmit Descriptor Link List Start Address Register	0xFFFF_FFFC
RXDLSA	0xFFFF0_308C	R/W	Receive Descriptor Link List Start Address Register	0xFFFF_FFFC
MCMDR	0xFFFF0_3090	R/W	MAC Command Register	0x0000_0000
MIID	0xFFFF0_3094	R/W	MII Management Data Register	0x0000_0000
MIIDA	0xFFFF0_3098	R/W	MII Management Control and Address Register	0x0090_0000
FFTCR	0xFFFF0_309C	R/W	FIFO Threshold Control Register	0x0000_0101
TSDR	0xFFFF0_30A0	W	Transmit Start Demand Register	Undefined
RSDR	0xFFFF0_30A4	W	Receive Start Demand Register	Undefined
DMARFC	0xFFFF0_30A8	R/W	Maximum Receive Frame Control Register	0x0000_0800
MIEN	0xFFFF0_30AC	R/W	MAC Interrupt Enable Register	0x0000_0000
Status Registers (11)				
MISTA	0xFFFF0_30B0	R/W	MAC Interrupt Status Register	0x0000_0000
MGSTA	0xFFFF0_30B4	R/W	MAC General Status Register	0x0000_0000
MPCNT	0xFFFF0_30B8	R/W	Missed Packet Count Register	0x0000_7FFF
MRPC	0xFFFF0_30BC	R	MAC Receive Pause Count Register	0x0000_0000
MRPCC	0xFFFF0_30C0	R	MAC Receive Pause Current Count Register	0x0000_0000
MREPC	0xFFFF0_30C4	R	MAC Remote Pause Count Register	0x0000_0000
DMARFS	0xFFFF0_30C8	R/W	DMA Receive Frame Status Register	0x0000_0000

W90P710CD/W90P710CDG



Continued.

REGISTER	ADDRESS	R/W	DESCRIPTION	RESET VALUE
Status Registers (11)				
CTXDSA	0xFFFF0_30CC	R	Current Transmit Descriptor Start Address Register	0x0000_0000
CTXBSA	0xFFFF0_30D0	R	Current Transmit Buffer Start Address Register	0x0000_0000
CRXDSA	0xFFFF0_30D4	R	Current Receive Descriptor Start Address Register	0x0000_0000
CRXBSA	0xFFFF0_30D8	R	Current Receive Buffer Start Address Register	0x0000_0000
Diagnostic Registers (7)				
RXFSM	0xFFFF0_3200	R	Receive Finite State Machine Register	0x0081_1101
TXFSM	0xFFFF0_3204	R	Transmit Finite State Machine Register	0x0101_1101
FSM0	0xFFFF0_3208	R	Finite State Machine Register 0	0x0001_0101
FSM1	0xFFFF0_320C	R	Finite State Machine Register 1	0x1100_0100
DCR	0xFFFF0_3210	R/W	Debug Configuration Register	0x0000_003F
DMMIR	0xFFFF0_3214	R	Debug Mode MAC Information Register	0x0000_0000
BISTR	0xFFFF0_3300	R/W	BIST Mode Register	0x0000_0000



6.5.2.1 Register Details

CAM Command Register (CAMCMR)

The W90P710 EMC supports the CAM function for destination MAC address recognition. The CAMCMR controls the CAM comparison function, and unicast, multicast, and broadcast packet reception.

REGISTER	ADDRESS	R/W	DESCRIPTION	RESET VALUE
CAMCMR	0xFFF0_3000	R/W	CAM Command Register	0x0000_0000

31	30	29	28	27	26	25	24
Reserved							
23	22	21	20	19	18	17	16
Reserved							
15	14	13	12	11	10	9	8
Reserved							
7	6	5	4	3	2	1	0
Reserved			ECMP	CCAM	ABP	AMP	AUP

BITS	DESCRIPTIONS	
[31:5]	Reserved	-
[4]	ECMP	<p>The ECMP(Enable CAM Compare) enables the CAM comparison function for destination MAC address recognition.</p> <p>For S/W to receive a packet with a specific destination MAC address, it configures the MAC address into any one of 16 CAM entries, and then enables that CAM entry and sets ECMP to 1.</p> <p>1'b0: Disable the CAM comparison function for destination MAC address recognition.</p> <p>1'b1: Enable the CAM comparison function for destination MAC address recognition.</p>
[3]	CCAM	<p>The CCAM(Complement CAM Compare) controls the complement of the CAM comparison result. If the ECMP and CCAM are both enabled, the incoming packet with specific destination MAC address configured in CAM entry is dropped. Incoming packets with a destination MAC address that isn't in any CAM entry is received.</p> <p>1'b0: The CAM comparison result isn't complemented.</p> <p>1'b1: The CAM comparison result is complemented.</p>



Continued.

BITS	DESCRIPTIONS	
[2]	ABP	<p>Accept Broadcast Packet controls broadcast packet reception. If ABP is enabled, the EMC receives all incoming packets; its destination MAC address is a broadcast address.</p> <p>1'b0: EMC receives packet depends on the CAM comparison result.</p> <p>1'b1: EMC receives all broadcast packets.</p>
[1]	AMP	<p>Accept Multicast Packet controls multicast packet reception. If AMP is enabled, the EMC receives all incoming packets; its destination MAC address is a multicast address.</p> <p>1'b0: EMC receives packet depends on the CAM comparison result.</p> <p>1'b1: EMC receives all multicast packets.</p>
[0]	AUP	<p>Accept Unicast Packet controls unicast packet reception. If AUP is enabled, EMC receives all incoming packets; its destination MAC address is a unicast address.</p> <p>1'b0: EMC receives packets depending on the CAM comparison result.</p> <p>1'b1: EMC receives all unicast packets.</p>

CAMCMR SETTING AND COMPARISON RESULT
<p>CAMCMR Setting and Comparison Result</p> <p>The following table is the address recognition result in different CAMCMR configurations. The Result column shows the incoming packet type that can pass the address recognition in specific CAM configuration. C, U, M and B represents the following:</p> <p><i>C</i>: Indicates the incoming packet destination MAC address is configured in CAM entry.</p> <p><i>U</i>: Indicates the incoming packet is a unicast packet.</p> <p><i>M</i>: Indicates the incoming packet is a multicast packet.</p> <p><i>B</i>: Indicates the incoming packet is a broadcast packet.</p>

W90P710CD/W90P710CDG



ECMP	CCAM	AUP	AMP	ABP	RESULT			
0	0	0	0	0	No Packet			
0	0	0	0	1	B			
0	0	0	1	0	M			
0	0	0	1	1	M	B		
0	0	1	0	0	C	U		
0	0	1	0	1	C	U	B	
0	0	1	1	0	C	U	M	
0	0	1	1	1	C	U	M	B
0	1	0	0	0	C	U	M	B
0	1	0	0	1	C	U	M	B
0	1	0	1	0	C	U	M	B
0	1	0	1	1	C	U	M	B
0	1	1	0	0	C	U	M	B
0	1	1	1	0	C	U	M	B
0	1	1	1	1	C	U	M	B
1	0	0	0	0	C			
1	0	0	0	1	C	B		
1	0	0	1	0	C	M		
1	0	0	1	1	C	N	B	
1	0	1	0	0	C	U		
1	0	1	0	1	C	U	B	
1	0	1	1	0	C	U	M	
1	0	1	1	1	C	U	M	B
1	1	0	0	0	U	M	B	
1	1	0	0	1	U	M	B	
1	1	0	1	0	U	M	B	
1	1	0	1	1	U	M	B	
1	1	1	0	0	C	U	M	B
1	1	1	0	1	C	U	M	B
1	1	1	1	0	C	U	M	B
1	1	1	1	1	C	U	M	B



CAM Enable Register (CAMEN)

CAMEN controls the validation of each CAM entry. Each CAM entry must be enabled first before it can participate in the destination MAC address recognition.

REGISTER	ADDRESS	R/W	DESCRIPTION	RESET VALUE
CAMEN	0xFFFF0_3004	R/W	CAM Enable Register	0x0000_0000

31	30	29	28	27	26	25	24
Reserved							
23	22	21	20	19	18	17	16
Reserved							
15	14	13	12	11	10	9	8
CAM15EN	CAM14EN	CAM13EN	CAM12EN	CAM11EN	CAM10EN	CAM9EN	CAM8EN
7	6	5	4	3	2	1	0
CAM7EN	CAM6EN	CAM5EN	CAM4EN	CAM3EN	CAM2EN	CAM1EN	CAM0EN

BITS	DESCRIPTIONS	
[31:16]		Reserved
[15:13]	CAM15EN CAM14EN CAM13EN	CAM entry 13, 14 and 15 are for frame transmission PAUSE control. For S/W to transmit a PAUSE control frame, each enable bit for the three CAM entries must first be enabled.
[12]	CAM12EN	CAM entry 12 is enabled 1'b0: CAM entry 12 disabled. 1'b1: CAM entry 12 enabled.
[11]	CAM11EN	CAM entry 11 is enabled 1'b0: CAM entry 11 disabled. 1'b1: CAM entry 11 enabled.
[10]	CAM10EN	CAM entry 10 is enabled 1'b0: CAM entry 10 disabled. 1'b1: CAM entry 10 enabled.

W90P710CD/W90P710CDG



Continued.

BITS	DESCRIPTIONS	
[9]	CAM9EN	CAM entry 9 is enabled 1'b0: CAM entry 9 disabled. 1'b1: CAM entry 9 enabled.
[8]	CAM8EN	CAM entry 8 is enabled 1'b0: CAM entry 8 disabled. 1'b1: CAM entry 8 enabled.
[7]	CAM7EN	CAM entry 7 is enabled 1'b0: CAM entry 7 disabled. 1'b1: CAM entry 7 enabled.
[6]	CAM6EN	CAM entry 6 is enabled 1'b0: CAM entry 6 disabled. 1'b1: CAM entry 6 enabled.
[5]	CAM5EN	CAM entry 5 is enabled 1'b0: CAM entry 5 disabled. 1'b1: CAM entry 5 enabled.
[4]	CAM4EN	CAM entry 4 is enabled 1'b0: CAM entry 4 disabled. 1'b1: CAM entry 4 enabled.
[3]	CAM3EN	CAM entry 3 is enabled 1'b0: CAM entry 3 disabled. 1'b1: CAM entry 3 enabled.
[2]	CAM2EN	CAM entry 2 is enabled 1'b0: CAM entry 2 disabled. 1'b1: CAM entry 2 enabled.
[1]	CAM1EN	CAM entry 1 is enabled 1'b0: CAM entry 1 disabled. 1'b1: CAM entry 1 enabled.
[0]	CAM0EN	CAM entry 0 is enabled 1'b0: CAM entry 0 disabled. 1'b1: CAM entry 0 enabled.



CAM Entry Registers (CAMxx)

REGISTER	ADDRESS	R/W	DESCRIPTION	RESET VALUE
CAM0M	0xFFF0_3008	R/W	CAM0 Most Significant Word Register	0x0000_0000
CAM0L	0xFFF0_300C	R/W	CAM0 Least Significant Word Register	0x0000_0000
CAM1M	0xFFF0_3010	R/W	CAM1 Most Significant Word Register	0x0000_0000
CAM1L	0xFFF0_3014	R/W	CAM1 Least Significant Word Register	0x0000_0000
CAM2M	0xFFF0_3018	R/W	CAM2 Most Significant Word Register	0x0000_0000
CAM2L	0xFFF0_301C	R/W	CAM2 Least Significant Word Register	0x0000_0000
CAM3M	0xFFF0_3020	R/W	CAM3 Most Significant Word Register	0x0000_0000
CAM3L	0xFFF0_3024	R/W	CAM3 Least Significant Word Register	0x0000_0000
CAM4M	0xFFF0_3028	R/W	CAM4 Most Significant Word Register	0x0000_0000
CAM4L	0xFFF0_302C	R/W	CAM4 Least Significant Word Register	0x0000_0000
CAM5M	0xFFF0_3030	R/W	CAM5 Most Significant Word Register	0x0000_0000
CAM5L	0xFFF0_3034	R/W	CAM5 Least Significant Word Register	0x0000_0000
CAM6M	0xFFF0_3038	R/W	CAM6 Most Significant Word Register	0x0000_0000
CAM6L	0xFFF0_303C	R/W	CAM6 Least Significant Word Register	0x0000_0000
CAM7M	0xFFF0_3040	R/W	CAM7 Most Significant Word Register	0x0000_0000
CAM7L	0xFFF0_3044	R/W	CAM7 Least Significant Word Register	0x0000_0000
CAM8M	0xFFF0_3048	R/W	CAM8 Most Significant Word Register	0x0000_0000
CAM8L	0xFFF0_304C	R/W	CAM8 Least Significant Word Register	0x0000_0000
CAM9M	0xFFF0_3050	R/W	CAM9 Most Significant Word Register	0x0000_0000
CAM9L	0xFFF0_3054	R/W	CAM9 Least Significant Word Register	0x0000_0000
CAM10M	0xFFF0_3058	R/W	CAM10 Most Significant Word Register	0x0000_0000
CAM10L	0xFFF0_305C	R/W	CAM10 Least Significant Word Register	0x0000_0000
CAM11M	0xFFF0_3060	R/W	CAM11 Most Significant Word Register	0x0000_0000
CAM11L	0xFFF0_3064	R/W	CAM11 Least Significant Word Register	0x0000_0000
CAM12M	0xFFF0_3068	R/W	CAM12 Most Significant Word Register	0x0000_0000
CAM12L	0xFFF0_306C	R/W	CAM12 Least Significant Word Register	0x0000_0000
CAM13M	0xFFF0_3070	R/W	CAM13 Most Significant Word Register	0x0000_0000
CAM13L	0xFFF0_3074	R/W	CAM13 Least Significant Word Register	0x0000_0000
CAM14M	0xFFF0_3078	R/W	CAM14 Most Significant Word Register	0x0000_0000
CAM14L	0xFFF0_307C	R/W	CAM14 Least Significant Word Register	0x0000_0000
CAM15M	0xFFF0_3080	R/W	CAM15 Most Significant Word Register	0x0000_0000
CAM15L	0xFFF0_3084	R/W	CAM15 Least Significant Word Register	0x0000_0000



CAMxM

31	30	29	28	27	26	25	24
MAC Address Byte 5 (MSB)							
23	22	21	20	19	18	17	16
MAC Address Byte 4							
15	14	13	12	11	10	9	8
MAC Address Byte 3							
7	6	5	4	3	2	1	0
MAC Address Byte 2							

BITS		DESCRIPTIONS
[31:0]	CAMxM	CAMxM (CAMx Most Significant Word) stores bits 47~16 of the MAC address. The x can be 0~14. The register pair {CAMxM, CAMxL} represents a CAM entry and can store a MAC address. For example, if the MAC address 00-50-BA-33-BA-44 is kept in CAM entry 1, the register CAM1M is 32'h0050_BA33 and CAM1L is 32'hBA44_0000.

CAMxL

31	30	29	28	27	26	25	24
MAC Address Byte 1							
23	22	21	20	19	18	17	16
MAC Address Byte 0 (LSB)							
15	14	13	12	11	10	9	8
Reserved							
7	6	5	4	3	2	1	0
Reserved							

BITS		DESCRIPTIONS
[31:16]	CAMxL	CAMxL(CAMx Least Significant Word) stores the bit 15~0 of MAC address. The x can be the 0~14. The register pair {CAMxM, CAMxL} represents a CAM entry and can store a MAC address. For example, if the MAC address 00-50-BA-33-BA-44 is kept in CAM entry 1, the register CAM1M is 32'h0050_BA33 and CAM1L is 32'hBA44_0000.
[15:0]	Reserved	-



CAM15M

31	30	29	28	27	26	25	24
Length/Type (MSB)							
23	22	21	20	19	18	17	16
Length/Type							
15	14	13	12	11	10	9	8
OP-Code (MSB)							
7	6	5	4	3	2	1	0
OP-Code							

BITS		DESCRIPTIONS
[31:0]	Length/Type	Length/Type Field of PAUSE Control Frame In the PAUSE control frame, a length/type field is defined as 16'h8808.
[15:0]	OP-Code	OP Code Field of PAUSE Control Frame In the PAUSE control frame, an op code field is defined as 16'h0001.

CAM15L

31	30	29	28	27	26	25	24
Operand (MSB)							
23	22	21	20	19	18	17	16
Operand							
15	14	13	12	11	10	9	8
Reserved							
7	6	5	4	3	2	1	0
Reserved							

BITS		DESCRIPTIONS
[31:16]	Operand	Pause Parameter, In the PAUSE control frame, an operand field is defined and controls how much time the destination Ethernet MAC Controller is paused. The operand unit is a 512-bit slot time.
[15:0]		Reserved

W90P710CD/W90P710CDG



Transmit Descriptor Link List Start Address Register (TXDLSA)

The Tx descriptor defined in the EMC is a link-list data structure. TXDLSA store the starting address of this link-list. In other words, the TXDLSA stores the starting address of the 1st Tx descriptor. S/W must configure TXDLSA before enabling the TXON bit of the MCMDR register .

REGISTER	ADDRESS	R/W	DESCRIPTION	RESET VALUE
TXDLSA	0xFFFF0_3088	R/W	Transmit Descriptor Link List Start Address Register	0xFFFF_FFFC

31	30	29	28	27	26	25	24
TXDLSA							
23	22	21	20	19	18	17	16
TXDLSA							
15	14	13	12	11	10	9	8
TXDLSA							
7	6	5	4	3	2	1	0
TXDLSA							

BITS	DESCRIPTIONS	
[31:0]	TXDLSA	The TXDLSA(Transmit Descriptor Link-List Start Address) stores the start address of the transmit descriptor linked-list. If S/W enables the TXON bit of the MCMDR register, the contents of TXDLSA are loaded into the current transmit descriptor start address register (CTXDSA). The TXDLSA isn't updated by the EMC. During operation, the EMC ignores bits [1:0] of TXDLSA. This means that each Tx descriptor must always be located on a memory address word boundary.

Receive Descriptor Link List Start Address Register (RXDLSA)

The Rx descriptor defined in the EMC is a linked-list data structure. RXDLSA stores the start address of this linked-list. In other words, RXDLSA stores the starting address of the 1st Rx descriptor. S/W must configure RXDLSA before enabling the RXON bit of the MCMDR register.

REGISTER	ADDRESS	R/W	DESCRIPTION	RESET VALUE
RXDLSA	0xFFFF0_308C	R/W	Receive Descriptor Link List Start Address Register	0xFFFF_FFFC



31	30	29	28	27	26	25	24
RXDLSA							
23	22	21	20	19	18	17	16
RXDLSA							
15	14	13	12	11	10	9	8
RXDLSA							
7	6	5	4	3	2	1	0
RXDLSA							

BITS		DESCRIPTIONS
[31:0]	RXDLSA	The RXDLSA(Receive Descriptor Link-List Start Address) stores the start address of the receive descriptor linked-list. If S/W enables the RXON bit of the MCMDR register, the contents of RXDLSA are loaded into the current receive descriptor start address register (CRXDLSA). RXDLSA isn't updated by the EMC. During operation, the EMC ignores bits [1:0] of RXDLSA. This means that each Rx descriptor must always be located on a memory address word boundary.

MAC Command Register (MCMDR)

The MCMDR provides control information for the EMC. Some command settings affect both frame transmission and reception, such as bit FDUP, the full/half duplex mode selection, or bit OPMOD, the 100/10M bps mode selection. Some command settings control frame transmission and reception separately, like TXON and RXON.

REGISTER	ADDRESS	R/W	DESCRIPTION	RESET VALUE
MCMDR	0xFFFF0_3090	R/W	MAC Command Register	0x0000_0000

31	30	29	28	27	26	25	24
Reserved							SWR
23	22	21	20	19	18	17	16
Reserved		LBK	OPMOD	EnMDC	FDUP	EnSQE	SDPZ
15	14	13	12	11	10	9	8
Reserved						NDEF	TXON
7	6	5	4	3	2	1	0
Reserved		SPCRC	AEP	ACP	ARP	ALP	RXON



BITS	DESCRIPTIONS	
[31:25]	Reserved	-
[24]	SWR	<p>SWR (Software Reset) implements a reset function to make the EMC return to its default state. The SWR is a self-clearing bit. This means that after software reset finished, the SWR is automatically cleared. Enabling SWR also resets all control and status registers, except for the OPMOD bit of the MCMDR register.</p> <p>EMC initialization is performed after the software reset is complete.</p> <p>1'b0: Software reset completed. 1'b1: Enable software reset.</p>
[23:22]	Reserved	-
[21]	LBK	<p>The LBK (Internal Loop Back Select) enables the EMC operating on internal loop-back mode. If the LBK is enabled, the packet transmitted is looped-back to Rx. If the EMC is operating on internal loop-back mode, it also means the EMC is operating in full-duplex mode and the FDUP bit of the MCMDR register is ignored. Besides, LBK is not affected by the SWR bit.</p> <p>1'b0: The EMC operates in normal mode. 1'b1: The EMC operates in internal loop-back mode.</p>
[20]	OPMOD	<p>Operation Mode Select defines if the EMC is operating in 10M or 100M bps mode. OPMOD is not affected by the SWR bit.</p> <p>1'b0: The EMC is operating in 10Mbps mode. 1'b1: The EMC is operating in 100Mbps mode.</p>
[19]	EnMDC	<p>Enable MDC Clock Generation controls the MDC clock generation for the MII Management Interface. If EnMDC is set to 1, MDC clock generation is enabled. Otherwise, MDC clock generation is disabled. Consequently, for S/W access to the external PHY registers through the MII Management Interface, the EnMDC must be set to high.</p> <p>1'b0: Disable MDC clock generation. 1'b1: Enable MDC clock generation.</p>
[18]	FDUP	<p>The Full Duplex Mode Select controls that EMC is operating on full or half duplex mode.</p> <p>1'b0: The EMC operates in half duplex mode. 1'b1: The EMC operates in full duplex mode.</p>

W90P710CD/W90P710CDG



Continued.

BITS	DESCRIPTIONS	
[17]	EnSQE	<p>The Enable SQE Checking controls the enable of SQE checking. The SQE checking is only available while EMC is operating on 10M bps and half duplex mode. In other words, the EnSQE cannot affect EMC operation, if the EMC is operating on 100M bps or full duplex mode.</p> <p>1'b0: Disable SQE checking while EMC is operating on 10Mbps and half duplex mode.</p> <p>1'b1: Enable SQE checking while EMC is operating on 10Mbps and half duplex mode.</p>
[16]	SDPZ	<p>The Send PAUSE Frame controls the PAUSE control frame transmission.</p> <p>To send a PAUSE control frame via S/W, the CAM entry 13, 14 and 15 must be configured first and the corresponding CAM enable bit of CAMEN register also must be set. Then, set SDPZ to 1 enables the PAUSE control frame transmission.</p> <p>The SDPZ is a self-clear bit. This means after the PAUSE control frame transmission has completed, the SDPZ is cleared automatically.</p> <p>It is recommended that only enables SPDZ while the EMC is operating in full duplex mode.</p> <p>1'b0: PAUSE control frame transmission is complete.</p> <p>1'b1: Enable the EMC to transmit a PAUSE control frame.</p>
[15:10]	Reserved	-
[9]	NDEF	<p>No Deferr enables the deferral exceed counter. If NDEF is set to high, the deferral exceed counter is disabled. NDEF is only useful while EMC is operating in half duplex mode.</p> <p>1'b0: Deferral exceed counter is enabled.</p> <p>1'b1: Deferral exceed counter is disabled.</p>



Continued.

BITS	DESCRIPTIONS	
[8]	TXON	<p>Frame Transmission ON controls normal EMC packet transmission . If TXON is set to high, the EMC starts the packet transmission process, including Tx descriptor fetching, packet transmission and Tx descriptor modification.</p> <p>It must finish the EMC initial sequence before enabling TXON. Otherwise, the EMC operation is undefined.</p> <p>If the TXON is disabled while the EMC is transmitting a packet, the EMC stops the packet transmission process after the current packet transmission is complete.</p> <p>1'b0: The EMC stops packet transmission. 1'b1: The EMC starts packet transmission.</p>
[7:6]	Reserved	-
[5]	SPCRC	<p>The Strip CRC Checksum determines if the length of the incoming packet is calculated with a 4-byte CRC checksum. If the SPCRC is set to high, the 4-byte CRC checksum is excluded from the length calculation of the incoming packet.</p> <p>1'b0: The 4-byte CRC checksum is included in the packet length calculation. 1'b1: The 4-byte CRC checksum is excluded in the packet length calculation.</p>
[4]	AEP	<p>Accept CRC Error Packet determines if the EMC accepts or drops the CRC error packet. If the AEP is set to high, the incoming packet with CRC error is received by the EMC as a good packet.</p> <p>1'b0: CRC error packet was dropped by the EMC. 1'b1: CRC error packet was accepted by the EMC.</p>
[3]	ACP	<p>Accept Control Packet determines control frame reception. If the ACP is set to high, the EMC accepts the control frame. Otherwise, the control frame is dropped.</p> <p>It is recommended that S/W only enable AEP when the EMC is operating in full duplex mode.</p> <p>1'b0: The control frame is dropped by the EMC. 1'b1: The control frame is accepted by the EMC.</p>



Continued.

BITS	DESCRIPTIONS	
[2]	ARP	<p>Accept Runt Packet controls runt packet (packets containing less than 64 bytes) reception. If the ARP is set to high, the EMC will accept the runt packet.</p> <p>Otherwise, the runt packet is dropped.</p> <p>1'b0: Runt packet was dropped by EMC.</p> <p>1'b1: Runt packet was accepted by EMC.</p>
[1]	ALP	<p>Accept Long Packet determines long packets (packets containing more than 1518 bytes) reception. If the ALP is set to high, the EMC accepts the long packet.</p> <p>Otherwise, the long packet is dropped.</p> <p>1'b0: The long packet was dropped by the EMC.</p> <p>1'b1: The long packet was accepted by the EMC.</p>
[0]	RXON	<p>Frame Reception ON controls the EMC normal packet reception. If RXON is set to high, the EMC starts the packet reception process, including fetching the Rx descriptor, packet reception and Rx descriptor modification.</p> <p>It the EMC initial sequence must finish before enabling RXON. Otherwise, the EMC operation is undefined.</p> <p>If RXON is disabled while the EMC is receiving an incoming packet, the EMC stops the packet reception process after the current packet reception is complete.</p> <p>1'b0: The EMC stops the packet reception process.</p> <p>1'b1: The EMC starts the packet reception process.</p>

MII Management Data Register (MIID)

The EMC provides the MII management function to access the control and status registers of the external PHY. The MIID register is used to store the data to be written into the registers of external PHY for write commands or the data that is read from the registers of external PHY for read commands.

REGISTER	ADDRESS	R/W	DESCRIPTION	RESET VALUE
MIID	0xFFFF0_3094	R/W	MII Management Data Register	0x0000_0000



31	30	29	28	27	26	25	24
Reserved							
23	22	21	20	19	18	17	16
Reserved							
15	14	13	12	11	10	9	8
MIIData							
7	6	5	4	3	2	1	0
MIIData							

BITS	DESCRIPTIONS	
[31:16]	Reserved	-
[15:0]	MIIData	MII Management Data is the 16-bit data that is written to the registers of external PHY for MII Management write command or the data from the registers of external PHY for MII Management read command.

MII Management Control and Address Register (MIIDA)

The EMC provides an MII management function to access the control and status registers of the external PHY. The MIIDA register is used to store the MII management command information, like the register address, external PHY address, MDC clocking rate, read/write etc.

REGISTER	ADDRESS	R/W	DESCRIPTION	RESET VALUE
MIIDA	0xFFFF0_3098	R/W	MII Management Control and Address Register	0x0090_0000

31	30	29	28	27	26	25	24
Reserved							
23	22	21	20	19	18	17	16
MDCCR				MDCON	PreSP	BUSY	Write
15	14	13	12	11	10	9	8
Reserved				PHYAD			
7	6	5	4	3	2	1	0
Reserved				PHYRAD			

W90P710CD/W90P710CDG



BITS	DESCRIPTIONS	
[31:24]	Reserved	-
[23:20]	MDCCR	<p>The MDC Clock Rating controls the MDC clock rating for MII Management I/F.</p> <p>Depending on the IEEE Std. 802.3 clause 22.2.2.11, the minimum period for the MDC shall be 400ns. In other words, the maximum frequency for the MDC is 2.5MHz. The MDC is divided from the AHB bus clock, the HCLK. Consequently, for different HCLKs the different ratios are required to generate an appropriate MDC clock.</p> <p>The following table shows the relationship between the HCLK and MDC clocks in different MDCCR configurations. The T_{HCLK} indicates the HCLK period.</p>
[19]	MDC	<p>The MDC Clock ON Always controls the MDC clock generation. If the MDCON is set to high, the MDC clock is always active. Otherwise, the MDC only activates while the S/W issues an MII management command.</p> <p>1'b0: The MDC clock is only active while the S/W issues a MII management command.</p> <p>1'b1: The MDC clock is always active.</p>
[18]	PreSP	<p>Preamble Suppress controls the preamble field generation of the MII management frame. If the PreSP is set to high, the preamble field generation of the MII management frame is skipped.</p> <p>1'b0: Preamble field generation of the MII management frame is not skipped.</p> <p>1'b1: Preamble field generation of the MII management frame is skipped.</p>
[17]	BUSY	<p>The Busy Bit enables MII management frame generation. For S/W access to the external PHY registers, the BUSY bit must be set high, and the EMC generates the MII management frame external PHY through MII Management I/F.</p> <p>The BUSY bit is self-clearing. This means the BUSY is cleared automatically after the MII management command finishes.</p> <p>1'b0: The MII management has finished.</p> <p>1'b1: Enable EMC generation of an MII management command to external PHY.</p>
[16]	Write	<p>The Write Command defines if the MII management command is read or write.</p> <p>1'b0: MII management command is a read command.</p> <p>1'b1: MII management command is a write command.</p>
[15:13]		Reserved

W90P710CD/W90P710CDG



Continued.

BITS		DESCRIPTIONS
[12:8]	PHYAD	The PHY Address stores the address to differentiate which external PHY is the target of the MII management command.
[7:5]	Reserved	-
[4:0]	PHYRAD	The PHY Register Address stores the address to indicate which register of the external PHY is the target of the MII management command.

MDCCR [23:20]	MDC CLOCK PERIOD	MDC CLOCK FREQUENCY
4'b0000	4 x T _{HCLK}	HCLK/4
4'b0001	6 x T _{HCLK}	HCLK/6
4'b0010	8 x T _{HCLK}	HCLK/8
4'b0011	12 x T _{HCLK}	HCLK/12
4'b0100	16 x T _{HCLK}	HCLK/16
4'b0101	20 x T _{HCLK}	HCLK/20
4'b0110	24 x T _{HCLK}	HCLK/24
4'b0111	28 x T _{HCLK}	HCLK/28
4'b1000	30 x T _{HCLK}	HCLK/30
4'b1001	32 x T _{HCLK}	HCLK/32
4'b1010	36 x T _{HCLK}	HCLK/36
4'b1011	40 x T _{HCLK}	HCLK/40
4'b1100	44 x T _{HCLK}	HCLK/44
4'b1101	48 x T _{HCLK}	HCLK/48
4'b1110	54 x T _{HCLK}	HCLK/54
4'b1111	60 x T _{HCLK}	HCLK/60

MII Management Function Frame Format

IEEE Std. 802.3 clause 22.2.4 defines the MII management function. The MII management function is used for the purpose of controlling the PHY and obtaining the status of the PHY. The MII management frame format is shown as follows.



Management frame fields								
	PRE	ST	OP	PHYAD	REGAD	TA	DATA	IDLE
READ	1...1	01	10	AAAAA	RRRRR	Z0	DDDDDDDDDDDDDDDDDD	Z
WRITE	1...1	01	01	AAAAA	RRRRR	10	DDDDDDDDDDDDDDDDDD	Z

MII Management Function Configure Sequence

READ	WRITE
1. Set appropriate MDCCR.	1. Write data to MIID register
2. Set PHYAD and PHYRAD.	2. Set appropriate MDCCR.
3. Set Write to 1'b0	3. Set PHYAD and PHYRAD.
4. Set bit BUSY to 1'b1 to send a MII management frame out.	4. Set Write to 1'b1
5. Wait BUSY to become 1'b0.	5. Set bit BUSY to 1'b1 to send a MII management frame out.
6. Read data from MIID register.	6. Wait BUSY to become 1'b0.
7. Finish the read command.	7. Finish the write command.

FIFO Threshold Control Register (FFTCR)

FFTCR defines the high and low threshold of internal FIFOs, including Tx FIFO and Rx FIFO. The threshold of internal FIFOs is related to EMC request generation and when the frame transmission starts. FFTCR also defines the burst length of AHB bus cycle for system memory access.

REGISTER	ADDRESS	R/W	DESCRIPTION	RESET VALUE
FFTCR	0xFFFF_309C	R/W	FIFO Threshold Control Register	0x0000_0101

31	30	29	28	27	26	25	24
Reserved							
23	22	21	20	19	18	17	16
Reserved		BLength		Reserved			
15	14	13	12	11	10	9	8
Reserved						TxTHD	
7	6	5	4	3	2	1	0
Reserved						RxTHD	



BITS	DESCRIPTIONS	
[31:22]	Reserved	-
[21:20]	Blength	<p>DMA Burst Length defines the burst length of the AHB bus cycle while the EMC accesses system memory.</p> <p>2'b00: 4 words 2'b01: 8 words 2'b10: 16 words 2'b11: 16 words</p>
[19:10]	Reserved	-
[9:8]	TxTHD	<p>TxFIFO Low Threshold controls when TxDMA requests internal arbiter for data transfer between system memory and TxFIFO. The TxTHD defines not only the low threshold of TxFIFO, but also the high threshold. The high threshold is always twice the low threshold. During packet transmission, if TxFIFO reaches the high threshold, the TxDMA stops generating requests to transfer frame data from system memory to TxFIFO. If the frame data in TxFIFO is less than the low threshold, TxDMA starts to transfer frame data from system memory to TxFIFO.</p> <p>The TxTHD also defines when the TxMAC starts to transmit frame. The TxMAC starts to transmit the frame while the TxFIFO first time reaches the high threshold during the transmission. If the frame data length is less than the TxFIFO high threshold, the TxMAC transmits the frame only after all the frame data are inside the TxFIFO.</p> <p>2'b00: Undefined. 2'b01: TxFIFO low threshold is 64B and high threshold is 128B. 2'b10: TxFIFO low threshold is 80B and high threshold is 160B. 2'b11: TxFIFO low threshold is 96B and high threshold is 192B.</p>
[7:2]		Reserved
[1:0]	RxTHD	<p>RxFIFO High Threshold controls when RxDMA requests the internal arbiter for data transfer between RxFIFO and system memory. The RxTHD defines not only the high threshold of RxFIFO, but also the low threshold. The low threshold is always half of the high threshold. During packet reception, if the RxFIFO reaches the high threshold, the RxDMA starts to transfer frame data from RxFIFO to system memory. If the frame data in RxFIFO is less than the low threshold, RxDMA stops transferring the frame data to system memory.</p> <p>2'b00: Depending on the burst length setting. If the burst length is 8 words, the high threshold is also 8 words. 2'b01: RxFIFO high threshold is 64B and low threshold is 32B. 2'b10: RxFIFO high threshold is 128B and low threshold is 64B. 2'b11: RxFIFO high threshold is 192B and low threshold is 96B.</p>



Transmit Start Demand Register (TSDR)

While the Tx descriptor is unavailable for use of TxDMA after TXON of the MCMDR register is enabled, the FSM (Finite State Machine) of TxDMA enters the Halt state, and the frame transmission is halted. After the S/W has prepared the new Tx descriptor for frame transmission, it must issue a write command to TSDR register to make TxDMA exit the Halt state and continue frame transmission. TSDR is a write only register, and reading from this register is undefined. The write to TSDR register only takes effect while TxDMA is in the Halt state.

REGISTER	ADDRESS	R/W	DESCRIPTION	RESET VALUE
TSDR	0xFFFF0_30A0	W	Transmit Start Demand Register	Undefined

BITS	DESCRIPTIONS	
[31:0]	Reserved	-

Receive Start Demand Register (RSDR)

If the RxDMA Rx descriptor is not available for use after RXON of the MCMDR register is enabled, the FSM (Finite State Machine) of RxDMA enters the Halt state and frame reception is halted. After S/W has prepared the new Rx descriptor for frame reception, it must issue a write command to the RSDR register to make RxDMA exit the Halt state and continue frame reception. The RSDR is a write only register and read from this register is undefined. The RSDR register write only takes affect when RxDMA is in the Halt state.

REGISTER	ADDRESS	R/W	DESCRIPTION	RESET VALUE
RSDR	0xFFFF0_30A4	W	Receive Start Demand Register	Undefined

BITS	DESCRIPTIONS	
[31:0]	Reserved	--

Maximum Receive Frame Control Register (DMARFC)

The DMARFC defines the maximum frame length for a received frame that can be stored in system memory. It is recommend to only use this register for receiving frame lengths greater than 1518 bytes.

REGISTER	ADDRESS	R/W	DESCRIPTION	RESET VALUE
DMARFC	0xFFFF0_30A8	R/W	Maximum Receive Frame Control Register	0x0000_0800

W90P710CD/W90P710CDG



31	30	29	28	27	26	25	24
Reserved							
23	22	21	20	19	18	17	16
Reserved							
15	14	13	12	11	10	9	8
RXMS							
7	6	5	4	3	2	1	0
RXMS							

BITS	DESCRIPTIONS	
[31:16]	Reserved	-
[15:0]	RXMS	<p>The Maximum Receive Frame Length defines the maximum frame length for received frames. If the frame length of the received frame is greater than the RXMS, and the EnDFO bit of the MIEN register is also enabled, the DFOI bit of the MISTA register is set and the Rx interrupt is triggered.</p> <p>It is recommended to only use RXMS to qualify the length of a received frame for S/W to receive a frame of length greater than 1518 bytes.</p>

MAC Interrupt Enable Register (MIEN)

The MIEN controls the enable of EMC interrupt status to generate interrupt. Two interrupts, RXINTR for frame reception and TXINTR for frame transmission, are generated from EMC to CPU.

REGISTER	ADDRESS	R/W	DESCRIPTION	RESET VALUE
MIEN	0xFFFF0_30AC	R/W	MAC Interrupt Enable Register	0x0000_0000

31	30	29	28	27	26	25	24
Reserved							EnTxBErr
23	22	21	20	19	18	17	16
EnTDU	EnLC	EnTXABT	EnNCS	EnEXDEF	EnTXCP	EnTXEMP	EnTXINTR
15	14	13	12	11	10	9	8
Reserved	EnCFR	Reserved		EnRxBErr	EnRDU	EnDEN	EnDFO
7	6	5	4	3	2	1	0
EnMMP	EnRP	EnALIE	EnRXGD	EnPTLE	EnRXOV	EnCRCE	EnRXINTR



BITS	DESCRIPTIONS	
[31:25]	Reserved	-
[24]	EnTxBErr	<p>Enable Transmit Bus Error Interrupt controls the TxBErr interrupt generation. If TxBErr of MISTA register is set, and both EnTxBErr and EnTXINTR are enabled, the EMC generates the Tx CPU interrupt. If EnTxBErr or EnTXINTR is disabled, no Tx CPU interrupt is generated even if the TxBErr of MISTA register is set.</p> <p>1'b0: TxBErr of MISTA register is masked from Tx interrupt generation. 1'b1: TxBErr of MISTA register can participate in Tx interrupt generation.</p>
[23]	EnTDU	<p>Enable Transmit Descriptor Unavailable Interrupt controls the TDU interrupt generation. If TDU of MISTA register is set, and both EnTDU and EnTXINTR are enabled, the EMC generates the Tx CPU interrupt. If EnTDU or EnTXINTR is disabled, no Tx CPU interrupt is generated even if the TDU of MISTA register is set.</p> <p>1'b0: TDU of MISTA register is masked from Tx interrupt generation. 1'b1: TDU of MISTA register can participate in Tx interrupt generation.</p>
[22]	EnLC	<p>Enable Late Collision Interrupt controls the LC interrupt generation. If LC of MISTA register is set, and both EnLC and EnTXINTR are enabled, the EMC generates the Tx CPU interrupt . If EnLC or EnTXINTR is disabled, no Tx interrupt is generated even if the LC of MISTA register is set.</p> <p>1'b0: LC of MISTA register is masked from Tx interrupt generation. 1'b1: LC of MISTA register can participate in Tx interrupt generation.</p>
[21]	EnTXABT	<p>Enable Transmit Abort Interrupt controls the TXABT interrupt generation. If TXABT of the MISTA register is set, and both EnTXABT and EnTXINTR are enabled, the EMC generates the Tx CPU interrupt . If EnTXABT or EnTXINTR is disabled, no Tx CPU interrupt is generated, even if the TXABT of MISTA register is set.</p> <p>1'b0: TXABT of MISTA register is masked from Tx interrupt generation. 1'b1: TXABT of MISTA register can participate in Tx interrupt generation.</p>
[20]	EnNCS	<p>Enable No Carrier Sense Interrupt controls NCS interrupt generation. If NCS of the MISTA register is set, and both EnNCS and EnTXINTR are enabled, the EMC generates the Tx CPU interrupt . If EnNCS or EnTXINTR is disabled, no Tx CPU interrupt is generated, even if the NCS of the MISTA register is set.</p> <p>1'b0: NCS of MISTA register is masked from Tx interrupt generation. 1'b1: NCS of MISTA register can participate in Tx interrupt generation.</p>



Continued.

BITS	DESCRIPTIONS	
[19]	EnEXDEF	<p>Enable Defer Exceed Interrupt controls EXDEF interrupt generation. If EXDEF of the MISTA register is set, and both EnEXDEF and EnTXINTR are enabled, the EMC generates the Tx CPU interrupt. If EnEXDEF or EnTXINTR is disabled, no Tx CPU interrupt is generated, even if the EXDEF of MISTA register is set.</p> <p>1'b0: EXDEF of MISTA register is masked from Tx interrupt generation. 1'b1: EXDEF of MISTA register can participate in Tx interrupt generation.</p>
[18]	EnTXCP	<p>The Enable Transmit Completion Interrupt controls the TXCP interrupt generation. If TXCP of MISTA register is set, and both EnTXCP and EnTXINTR are enabled, the EMC generates the Tx CPU interrupt. If EnTXCP or EnTXINTR is disabled, no Tx CPU interrupt is generated, even if the TXCP of MISTA register is set.</p> <p>1'b0: TXCP of MISTA register is masked from Tx interrupt generation. 1'b1: TXCP of MISTA register can participate in Tx interrupt generation.</p>
[17]	EnTXEMP	<p>The Enable Transmit FIFO Underflow Interrupt controls the TXEMP interrupt generation. If TXEMP of MISTA register is set, and both EnTXEMP and EnTXINTR are enabled, the EMC generates the Tx CPU interrupt. If EnTXEMP or EnTXINTR is disabled, no Tx CPU interrupt is generated, even if the TXEMP of MISTA register is set.</p> <p>1'b0: TXEMP of MISTA register is masked from Tx interrupt generation. 1'b1: TXEMP of MISTA register can participate in Tx interrupt generation.</p>
[16]	EnTXINTR	<p>The EnTXINTR controls the Tx interrupt generation.</p> <p>If Enable Transmit Interrupt is enabled and TXINTR of the MISTA register is high, EMC generates the Tx CPU interrupt. If EnTXINTR is disabled, no Tx CPU interrupt is generated, even if the status bits 17~24 of MISTA are set and the corresponding bits of MIEN are enabled. In other words, for S/W to receive a Tx interrupt from EMC, this bit must be enabled. And, if S/W doesn't want to receive any Tx interrupt from EMC, disables this bit.</p> <p>1'b0: TXINTR of MISTA register is masked and Tx interrupt generation is disabled. 1'b1: TXINTR of MISTA register is unmasked and Tx interrupt generation is enabled.</p>
[15]	Reserved	--
[14]	EnCFR	<p>Enable Control Frame Receive Interrupt controls CFR interrupt generation. If CFR of the MISTA register is set, and both EnCFR and EnTXINTR are enabled, the EMC generates the Rx CPU interrupt. If EnCFR or EnTXINTR is disabled, no Rx CPU interrupt is generated, even if the CFR of MISTA register is set.</p> <p>1'b0: CFR of MISTA register is masked from Rx interrupt generation. 1'b1: CFR of MISTA register can participate in Rx interrupt generation.</p>



Continued.

BITS	DESCRIPTIONS	
[13:12]	Reserved	--
[11]	EnRxBErr	<p>The Enable Receive Bus Error Interrupt controls the RxBErr interrupt generation. If RxBErr of the MISTA register is set, and both EnRxBErr and EnTXINTR are enabled, the EMC generates the Rx CPU interrupt. If EnRxBErr or EnTXINTR is disabled, no Rx CPU interrupt is generated, even if the RxBErr of the MISTA register is set.</p> <p>1'b0: RxBErr of the MISTA register is masked from Rx interrupt generation.</p> <p>1'b1: RxBErr of the MISTA register can participate in Rx interrupt generation.</p>
[10]	EnRDU	<p>Enable Receive Descriptor Unavailable Interrupt controls RDU interrupt generation. If RDU of MISTA register is set, and both EnRDU and EnTXINTR are enabled, the EMC generates the Rx CPU interrupt. If EnRDU or EnTXINTR is disabled, no Rx CPU interrupt is generated, even if the RDU of MISTA register is set.</p> <p>1'b0: RDU of MISTA register is masked from Rx interrupt generation.</p> <p>1'b1: RDU of MISTA register can participate in Rx interrupt generation.</p>
[9]	EnDEN	<p>Enable DMA Early Notification Interrupt controls DENI interrupt generation. If DENI of the MISTA register is set, and both EnDEN and EnTXINTR are enabled, the EMC generates the Rx CPU interrupt. If EnDEN or EnTXINTR is disabled, no Rx CPU interrupt is generated, even if the DENI of MISTA register is set.</p> <p>1'b0: DENI of MISTA register is masked from Rx interrupt generation.</p> <p>1'b1: DENI of MISTA register can participate in Rx interrupt generation.</p>
[8]	EnDFO	<p>Enable Maximum Frame Length Interrupt controls the DFOI interrupt generation. If DFOI of MISTA register is set, and both EnDFO and EnTXINTR are enabled, the EMC generates the Rx CPU interrupt. If EnDFO or EnTXINTR is disabled, no Rx CPU interrupt is generated, even if the DFOI of MISTA register is set.</p> <p>1'b0: DFOI of MISTA register is masked from Rx interrupt generation.</p> <p>1'b1: DFOI of MISTA register can participate in Rx interrupt generation.</p>
[7]	EnMMP	<p>The Enable More Missed Packet Interrupt controls the MMP interrupt generation. If MMP of MISTA register is set, and both EnMMP and EnTXINTR are enabled, the EMC generates the Rx CPU interrupt. If EnMMP or EnTXINTR is disabled, no Rx CPU interrupt is generated, even if the MMP of MISTA register is set.</p> <p>1'b0: MMP of MISTA register is masked from Rx interrupt generation.</p> <p>1'b1: MMP of MISTA register can participate in Rx interrupt generation.</p>



Continued.

BITS	DESCRIPTIONS	
[6]	EnRP	<p>Enable Runt Packet Interrupt controls the RP interrupt generation. If RP of MISTA register is set, and both EnRP and EnTXINTR are enabled, the EMC generates the Rx CPU interrupt. If EnRP or EnTXINTR is disabled, no Rx CPU interrupt is generated, even if the RP of MISTA register is set.</p> <p>1'b0: RP of MISTA register is masked from Rx interrupt generation. 1'b1: RP of MISTA register can participate in Rx interrupt generation.</p>
[5]	EnALIE	<p>Enable Alignment Error Interrupt controls ALIE interrupt generation. If ALIE of MISTA register is set, and both EnALIE and EnTXINTR are enabled, the EMC generates the Rx CPU interrupt. If EnALIE or EnTXINTR is disabled, no Rx CPU interrupt is generated, even if the ALIE of MISTA register is set.</p> <p>1'b0: ALIE of MISTA register is masked from Rx interrupt generation. 1'b1: ALIE of MISTA register can participate in Rx interrupt generation.</p>
[4]	EnRXGD	<p>Enable Receive Good Interrupt controls the RXGD interrupt generation. If RXGD of the MISTA register is set, and both EnRXGD and EnTXINTR are enabled, the EMC generates the Rx CPU interrupt. If EnRXGD or EnTXINTR is disabled, no Rx CPU interrupt is generated, even if the RXGD of MISTA register is set.</p> <p>1'b0: RXGD of MISTA register is masked from Rx interrupt generation. 1'b1: RXGD of MISTA register can participate in Rx interrupt generation.</p>
[3]	EnPTLE	<p>Enable Packet Too Long Interrupt controls the PTLE interrupt generation. If PTLE of MISTA register is set, and both EnPTLE and EnTXINTR are enabled, the EMC generates the Rx CPU interrupt. If EnPTLE or EnTXINTR is disabled, no Rx CPU interrupt is generated, even if the PTLE of MISTA register is set.</p> <p>1'b0: PTLE of MISTA register is masked from Rx interrupt generation. 1'b1: PTLE of MISTA register can participate in Rx interrupt generation.</p>
[2]	EnRXOV	<p>Enable Receive FIFO Overflow Interrupt controls the RXOV interrupt generation. If RXOV of MISTA register is set, and both EnRXOV and EnTXINTR are enabled, the EMC generates the Rx CPU interrupt. If EnRXOV or EnTXINTR is disabled, no Rx CPU interrupt is generated, even if the RXOV of MISTA register is set.</p> <p>1'b0: RXOV of MISTA register is masked from Rx interrupt generation. 1'b1: RXOV of MISTA register can participate in Rx interrupt generation.</p>
[1]	EnCRCE	<p>Enable CRC Error Interrupt controls the CRCE interrupt generation. If CRCE of the MISTA register is set, and both EnCRCE and EnTXINTR are enabled, the EMC generates the Rx CPU interrupt. If EnCRCE or EnTXINTR is disabled, no Rx CPU interrupt is generated, even if the CRCE of MISTA register is set.</p> <p>1'b0: CRCE of MISTA register is masked from Rx interrupt generation. 1'b1: CRCE of MISTA register can participate in Rx interrupt generation.</p>



Continued.

BITS	DESCRIPTIONS	
[0]	EnRXINTR	<p>Enable Receive Interrupt controls the Rx interrupt generation.</p> <p>If EnRXINTR is enabled and RXINTR of the MISTA register is high, EMC generates the Rx CPU interrupt. If EnRXINTR is disabled, no Rx CPU interrupt is generated, even if the status bits 1~14 of MISTA are set and the corresponding bits of MIEN are enabled. In other words, for S/W to receive an Rx interrupt from EMC, this bit must be enabled. And, if S/W doesn't want to receive any Rx interrupt from EMC, disables this bit.</p> <p>1'b0: RXINTR of the MISTA register is masked and Rx interrupt generation is disabled.</p> <p>1'b1: RXINTR of the MISTA register is unmasked and Rx interrupt generation is enabled.</p>

MAC Interrupt Status Register (MISTA)

The MISTA stores many EMC states, like frame transmission and reception status, internal FIFO status and also NATA processing status. The statuses stored in MISTA will trigger the reception or transmission interrupt. The MISTA is a "write clear" register so writing to a bit on this register clears its value; it also clears the interrupt.

REGISTER	ADDRESS	R/W	DESCRIPTION	RESET VALUE
MISTA	0xFFFF0_30B0	R/W	MAC Interrupt Status Register	0x0000_0000

31	30	29	28	27	26	25	24
Reserved							TxBErr
23	22	21	20	19	18	17	16
TDU	LC	TXABT	NCS	EXDEF	TXCP	TXEMP	TXINTR
15	14	13	12	11	10	9	8
Reserved	CFR	Reserved		RxBErr	RDU	DENI	DFOI
7	6	5	4	3	2	1	0
MMP	RP	ALIE	RXGD	PTLE	RXOV	CRCE	RXINTR



BITS	DESCRIPTIONS	
[31:25]	Reserved	-
[24]	TxBErr	<p>Transmit Bus Error Interrupt high is a memory controller ERROR response during EMC access to system memory through TxDMA during the packet transmission process. Resetting the EMC is recommended while the TxBErr status is high.</p> <p>If the TxBErr is high and EnTxBErr of the MIEN register is enabled, the TxINTR is high. Write 1 to this bit clears the TxBErr status.</p> <p>1'b0: No ERROR response received. 1'b1: ERROR response received.</p>
[23]	TDU	<p>Transmit Descriptor Unavailable Interrupt high indicates there is no available Tx descriptor for packet transmission and TxDMA will remain in the Halt state. Once the TxDMA enters the Halt state, S/W must issue a write command to the TSDR register to make TxDMA exit the Halt state when the new Tx descriptor is available.</p> <p>If the TDU is high and EnTDU of the MIEN register is enabled, the TxINTR is high. Write 1 to this bit clears the TDU status.</p> <p>1'b0: Tx descriptor is available. 1'b1: Tx descriptor is unavailable.</p>
[22]	LC	<p>Late Collision Interrupt high indicates the collision occurred outside the 64-byte collision window. This means that after the 64-byte frame was transmitted, a collision still occurred. The late collision check is only performed while EMC is operating in half duplex mode.</p> <p>If the LC is high and EnLC of the MIEN register is enabled, the TxINTR is high. Write 1 to this bit clears the LC status.</p> <p>1'b0: No collision occurred outside the 64-byte collision window. 1'b1: Collision occurred outside the 64-byte collision window.</p>
[21]	TXABT	<p>Transmit Abort Interrupt high indicates the packet incurred 16 consecutive collisions during transmission, and the transmission process for this packet was aborted. The transmission abort is only available while EMC is operating in half duplex mode.</p> <p>If the TXABT is high and EnTXABT of the MIEN register is enabled, the TxINTR is high. Write 1 to this bit clears the TXABT status.</p> <p>1'b0: Packet doesn't incur 16 consecutive collisions during transmission. 1'b1: Packet incurred 16 consecutive collisions during transmission.</p>



Continued.

BITS	DESCRIPTIONS	
[20]	NCS	<p>No Carrier Sense Interrupt high indicates the MII I/F signal CRS was not active at the start of or during packet transmission. The NCS is only available while the EMC is operating in half duplex mode.</p> <p>If the NCS is high and deEnNCS of the MIEN register is enabled, the TxINTR is high. Write 1 to this bit clears the NCS status.</p> <p>1'b0: CRS signal operates correctly. 1'b1: CRS signal was not active at the start of or during packet transmission.</p>
[19]	EXDEF	<p>The Defer Exceed Interrupt high indicates the frame waiting for transmission has deferred over 0.32768ms on 100Mbps mode, or 3.2768ms on 10Mbps mode. The deferral exceed check is only performed while bit NDEF of MCMADR is disabled, and the EMC operates in half duplex mode.</p> <p>If the EXDEF is high and EnEXDEF of the MIEN register is enabled, the TxINTR is high. Write 1 to this bit clears the EXDEF status.</p> <p>1'b0: Frame waiting for transmission has not deferred over 0.32768ms (100Mbps) or 3.2768ms (10Mbps). 1'b1: Frame waiting for transmission has deferred over 0.32768ms (100Mbps) or 3.2768ms (10Mbps).</p>
[18]	TXCP	<p>Transmit Completion Interrupt indicates packet transmission has completed correctly.</p> <p>If the TXCP is high and EnTXCP of the MIEN register is enabled, the TxINTR is high. Writing 1 to this bit clears the TXCP status.</p> <p>1'b0: Packet transmission isn't complete. 1'b1: Packet transmission is complete.</p>
[17]	TXEMP	<p>Transmit FIFO Underflow Interrupt high indicates a Tx FIFO underflow occurred during packet transmission. While the Tx FIFO underflow occurred, the EMC automatically retransmits the packet without S/W intervention. If the Tx FIFO underflow occurs often, it is recommended to modify the Tx FIFO threshold control, and the TxTHD of the FFTCR register, to a higher level.</p> <p>If the TXEMP is high and EnTXEMP of the MIEN register is enabled, the TxINTR is high. Writing 1 to this bit clears the TXEMP status.</p> <p>1'b0: No Tx FIFO underflow occurred during packet transmission. 1'b1: Tx FIFO underflow occurred during packet transmission.</p>



Continued.

BITS	DESCRIPTIONS	
[16]	TXINTR	<p>Transmit Interrupt indicates the Tx interrupt status.</p> <p>If TXINTR is high and its corresponding enable bit, EnTXINTR of the MISTA register, is also high, it indicates the EMC generated a Tx CPU interrupt. If TXINTR is high but EnTXINTR of MISTA is disabled, no Tx interrupt is generated.</p> <p>TXINTR logic OR result of bits 17~24 in the MISTA register perform logic AND with the corresponding bits in MIEN register. In other words, if one of the bits 17~24 in the MISTA register is high and its corresponding enable bit in the MIEN register is also enabled, the TXINTR is high. Because the TXINTR is a logic OR result, clears bits 17~24 of MISTA register also clears TXINTR as well.</p> <p>1'b0: None of status bits 17~24 in MISTA are set or none of their corresponding enable bits in MIEN is turned on.</p> <p>1'b1: At least one of status bits 17~24 in MISTA are set, and a corresponding enable bit is turned on.</p>
[15]		Reserved
[14]	CFR	<p>Control Frame Receive Interrupt high indicates EMC received a flow control frame. The CFR is only available while the EMC is operating in full duplex mode.</p> <p>If the CFR is high and EnCFR of the MIEN register is enabled, the RxINTR is high. Writing 1 to this bit clears the CFR status.</p> <p>1'b0: The EMC doesn't receive the flow control frame.</p> <p>1'b1: The EMC receives a flow control frame.</p>
[13:12]		Reserved
[11]	RxBErr	<p>Receive Bus Error Interrupt high indicates a memory controller ERROR response during EMC system memory access through RxDMA during the packet reception process. Resetting the EMC is recommended while RxBErr status is high.</p> <p>If the RxBErr is high and EnRxBErr of the MIEN register is enabled, the RxINTR is high. Writing 1 to this bit clears the RxBErr status.</p> <p>1'b0: No ERROR response received.</p> <p>1'b1: ERROR response received.</p>



[10]	RDU	<p>Receive Descriptor Unavailable Interrupt high indicates there is no available Rx descriptor for packet reception and RxDMA remains in the Halt state. Once the RxDMA enters the Halt state, S/W must issue a write command to the RSDR register to make RxDMA exit Halt state when new Rx descriptor is available.</p> <p>If the RDU is high and EnRDU of the MIEN register is enabled, the RxINTR is high. Writing 1 to this bit clears the RDU status.</p> <p>1'b0: Rx descriptor is available. 1'b1: Rx descriptor is unavailable.</p>
------	-----	---



Continued.

BITS	DESCRIPTIONS	
[9]	DENI	<p>DMA Early Notification Interrupt high indicates the EMC has received the Length/Type field of the incoming packet.</p> <p>If DENI is high and EnDENI of the MIEN register is enabled, the RxINTR is high. Writing 1 to this bit clears the DENI status.</p> <p>1'b0: No incoming packet Length/Type field received. 1'b1: Incoming packet Length/Type field received.</p>
[8]	DFOI	<p>Maximum Frame Length Interrupt high indicates the length of the incoming packet has exceeded the length limitation configured in the DMARFC register and the incoming packet is dropped. If the DFOI is high and EnDFOI of the MIEN register is enabled, RxINTR is high. Writing 1 to this bit clears the DFOI status.</p> <p>1'b0: The length of the incoming packet doesn't exceed the length limitation configured in DMARFC. 1'b1: The length of the incoming packet has exceeded the length limitation configured in DMARFC.</p>
[7]	MMP	<p>More Missed Packet Interrupt high indicates the MPCNT, Missed Packet Count, has overflowed. If the MMP is high and EnMMP of the MIEN register is enabled, the RxINTR is high. Writing 1 to this bit clears the MMP status.</p> <p>1'b0: MPCNT has not rolled over yet. 1'b1: MPCNT has rolled over.</p>
[6]	RP	<p>Runt Packet (RP) Interrupt</p> <p>RP high indicates the length of the incoming packet was less than 64 bytes and was dropped. If the ARP of MCMDR register is set, the short packet is regarded as a good packet and the RP is not set.</p> <p>If the RP is high and EnRP of the MIEN register is enabled, RxINTR is high. Writing 1 to this bit clears the RP status.</p> <p>1'b0: The incoming frame is not a short frame or S/W needs to receive a short frame. 1'b1: The incoming frame is a short frame and was dropped.</p>
[5]	ALIE	<p>Alignment Error Interrupt high indicates the length of the incoming frame is not a multiple of byte.</p> <p>If the ALIE is high and EnALIE of the MIEN register is enabled, the RxINTR is high. Writing 1 to this bit clears the ALIE status.</p> <p>1'b0: The frame length is a multiple of byte. 1'b1: The frame length is not a multiple of byte.</p>



Continued.

BITS	DESCRIPTIONS	
[4]	RXGD	<p>Receive Good Interrupt high indicates frame reception is complete. If the RXGD is high and EnRXGD of the MIEN register is enabled, the RxINTR is high. Writing 1 to this bit clears the RXGD status.</p> <p>1'b0: Frame reception is not yet complete. 1'b1: Frame reception is complete.</p>
[3]	PTLE	<p>Packet Too Long Interrupt high indicates the length of the incoming packet is greater than 1518 bytes and was dropped. If the ALP of MCMMDR register is set, the long packet is regarded as a good packet and PTLE is not set.</p> <p>If the PTLE is high and EnPTLE of the MIEN register is enabled, the RxINTR is high. Writing 1 to this bit clears the PTLE status.</p> <p>1'b0: Incoming frame is not a long frame or S/W needs to receive a long frame. 1'b1: Incoming frame is a long frame and was dropped.</p>
[2]	RXOV	<p>Receive FIFO Overflow Interrupt high indicates RxFIFO overflow occurred during packet reception. While the RxFIFO overflow occurred, the EMC dropped the current receiving packet. If the RxFIFO overflow occurs often, it is recommended to modify the RxFIFO threshold and the RxTHD of the FFTCR register to a higher level.</p> <p>If the RXOV is high and EnRXOV of the MIEN register is enabled, the RxINTR is high. Writing 1 to this bit clears the RXOV status.</p> <p>1'b0: No RxFIFO overflow occurred during packet reception. 1'b1: RxFIFO overflow occurred during packet reception.</p>
[1]	CRCE	<p>CRC Error Interrupt high indicates the incoming packet incurred the CRC error and the packet is dropped. If the AEP of the MCMMDR register is set, the CRC error packet is regarded as a good packet and CRCE is not set.</p> <p>If the CRCE is high and EnCRCE of the MIEN register is enabled, the RxINTR is high. Writing 1 to this bit clears the CRCE status.</p> <p>1'b0: Frame didn't incur any CRC error. 1'b1: Frame incurred CRC error.</p>



Continued.

BITS	DESCRIPTIONS	
[0]	RXINTR	<p>Receive Interrupt indicates the Rx interrupt status.</p> <p>If RXINTR is high, and the corresponding EnRXINTR enable bit of the MISTA register is also high, it indicates the EMC generated an Rx CPU interrupt. If RXINTR is high but EnRXINTR of MISTA is disabled, no Rx interrupt is generated.</p> <p>The RXINTR is the logic OR result of bits 1~14 of the MISTA register and logic AND with the corresponding bits of the MIEN register. In other words, if one of the bits 1~14 in MISTA register is high and its corresponding enable bit in the MIEN register is also enabled, the RXINTR is high.</p> <p>Because the RXINTR is a logic OR result, this clears bits 1~14 of the MISTA register which also clears RXINTR as well.</p> <p>1'b0: None of status bits 1~14 in MISTA is set or none of the enable bits 1~14 in MIEN is turned on.</p> <p>1'b1: At least one status bit 1~14 in MISTA is set and its corresponding enable bit is turned on.</p>

MAC General Status Register (MGSTA)

MGSTA also stores the status of the EMC. But the MGSTA does not trigger any interrupt. The MGSTA is a write clear register, and writing 1 to corresponding bit clears its status.

REGISTER	ADDRESS	R/W	DESCRIPTION	RESET VALUE
MGSTA	0xFFFF0_30B4	R/W	MAC General Status Register	0x0000_0000

31	30	29	28	27	26	25	24
Reserved							
23	22	21	20	19	18	17	16
Reserved							
15	14	13	12	11	10	9	8
Reserved				TXHA	SQE	PAU	DEF
7	6	5	4	3	2	1	0
CCNT				Reserved	RFFull	RXHA	CFR

W90P710CD/W90P710CDG



BITS	DESCRIPTIONS	
[31:12]	Reserved	-
[11]	TXHA	<p>Transmission Halted high indicates the next normal packet transmission process is halted because the bit TXON of MCMADR is disabled by S/W.</p> <p>1'b0: Next normal packet transmission process will go on.</p> <p>1'b1: Next normal packet transmission process is halted.</p>
[10]	SQE	<p>Signal Quality Error high indicates the SQE error found at end of packet transmission on 10Mbps half-duplex mode. The SQE error check is only performed while both bit EnSQE of MCMADR is enabled and EMC is operating on 10Mbps half-duplex mode.</p> <p>1'b0: No SQE error found at end of packet transmission.</p> <p>1'b1: SQE error found at end of packet transmission.</p>
[9]	PAU	<p>Transmission Paused high indicates the next normal packet transmission process is paused temporarily because the EMC received a PAUSE control frame, or S/W set bit SDPZ of MCMADR and causes the EMC to transmit a PAUSE control frame.</p> <p>1'b0: Next normal packet transmission process continues.</p> <p>1'b1: Next normal packet transmission process is paused.</p>
[8]	DEF	<p>Deferred Transmission high indicates the packet transmission has deferred once. The DEF is only available while EMC is operating in half duplex mode.</p> <p>1'b0: Packet transmission didn't defer.</p> <p>1'b1: Packet transmission has deferred once.</p>
[7:4]	CCNT	<p>Collision Count indicates the how many consecutive collisions occurred during packet transmission. If the packet incurred 16 consecutive collisions during transmission, the CCNT is 4'h0 and bit TXABT is set to 1.</p>
[3]	Reserved	-
[2]	RFFull	<p>RxFIFO Full indicates the RxFIFO is full due to four 64-byte packets stored in RxFIFO and the following incoming packet is dropped.</p> <p>1'b0: The RxFIFO is not full.</p> <p>1'b1: The RxFIFO is full and the following incoming packet is dropped.</p>
[1]	RXHA	<p>Receive Halted high indicates the next normal packet reception process is halted because the bit RXON of MCMADR is disabled by S/W.</p> <p>1'b0: Next normal packet reception process continues.</p> <p>1'b1: Next normal packet reception process is halted.</p>
[0]	CFR	<p>Control Frame Received high indicates EMC receives a flow control frame. The CFR is only available while the EMC is operating in full duplex mode.</p> <p>1'b0: EMC doesn't receive the flow control frame.</p> <p>1'b1: EMC receives a flow control frame.</p>



Missed Packet Count Register (MPCNT)

MPCNT stores the number of packets that were dropped due to various types of receive errors. The MPCNT is a read clear register. In addition, S/W also can write an initial value to MPCNT and the missed packet counter starts counting from that initial value. If the missed packet counter overflows, the MMP of MISTA is set.

REGISTER	ADDRESS	R/W	DESCRIPTION	RESET VALUE
MPCNT	0xFFF0_30B8	R/W	Missed Packet Count Register	0x0000_7FFF

31	30	29	28	27	26	25	24
Reserved							
23	22	21	20	19	18	17	16
Reserved							
15	14	13	12	11	10	9	8
MPC							
7	6	5	4	3	2	1	0
MPC							

BITS	DESCRIPTIONS	
[31:16]	Reserved	-
[15:0]	MPC	<p>Miss Packet Count indicates the number of packets that were dropped due to various types of receive errors. The following type of receive error increments the missed packet counter:</p> <ul style="list-style-type: none"> ▪ Incoming packet incurred Rx FIFO overflow. ▪ Incoming packet is dropped due to disabled RXON. ▪ Incoming packet incurred CRC error.

MAC Receive Pause Count Register (MRPC)

EMC of W90P710 supports the PAUSE control frame reception and recognition. If the EMC received a PAUSE control frame, the operand field of the PAUSE control frame is extracted and stored in the MRPC register. The MRPC register stores the same while Tx of the EMC receives the PAUSE control frame and halts. The MRPC is read only and writing to this register has no effect.

REGISTER	ADDRESS	R/W	DESCRIPTION	RESET VALUE
MRPC	0xFFF0_30BC	R	MAC Receive Pause Count Register	0x0000_0000

W90P710CD/W90P710CDG



31	30	29	28	27	26	25	24
Reserved							
23	22	21	20	19	18	17	16
Reserved							
15	14	13	12	11	10	9	8
MRPC							
7	6	5	4	3	2	1	0
MRPC							

BITS	DESCRIPTIONS	
[31:16]	Reserved	-
[15:0]	MRPC	MAC Receive Pause Count stores the operand field of the PAUSE control frame. It indicates for how many slot times (512 bit times) the Tx of EMC was paused.

MAC Receive Pause Current Count Register (MRPCC)

The EMC of W90P710 supports the PAUSE control frame reception and recognition. If EMC received a PAUSE control frame, the operand field of the PAUSE control frame is extracted and stored into a count down timer. The MRPCC shows the current value of that countdown timer for S/W to know how long the EMC Tx was paused. MRPCC is read only and writing to this register has no effect.

REGISTER	ADDRESS	R/W	DESCRIPTION	RESET VALUE
MRPCC	0xFFFF0_30C0	R	MAC Receive Pause Current Count Register	0x0000_0000

31	30	29	28	27	26	25	24
Reserved							
23	22	21	20	19	18	17	16
Reserved							
15	14	13	12	11	10	9	8
MRPCC							
7	6	5	4	3	2	1	0
MRPCC							

W90P710CD/W90P710CDG



BITS	DESCRIPTIONS	
[31:16]	Reserved	-
[15:0]	MRPCC	MAC Receive Pause Current Count shows the current value of the countdown timer. If a new PAUSE control frame is received before the timer reaches zero, the new operand of the PAUSE control frame is stored into the countdown timer, and the timer starts count down from the new value.

MAC Remote Pause Count Register (MREPC)

W90P710 EMC supports PAUSE control frame transmission. After the PAUSE control frame is completely transmitted, a timer starts to count down from the operand value of the transmitted PAUSE control frame. The MREPC shows the current value of this countdown timer. The MREPC is read only and writing to this register has no effect.

REGISTER	ADDRESS	R/W	DESCRIPTION	RESET VALUE
MREPC	0xFFFF0_30C4	R	MAC Remote Pause Count Register	0x0000_0000

31	30	29	28	27	26	25	24
Reserved							
23	22	21	20	19	18	17	16
Reserved							
15	14	13	12	11	10	9	8
MREPC							
7	6	5	4	3	2	1	0
MREPC							

BITS	DESCRIPTIONS	
[31:16]	Reserved	
[15:0]	MREPC	MAC Remote Pause Count shows the current value of the countdown timer that counts down from the operand value of the transmitted PAUSE control frame.



DMA Receive Frame Status Register (DMARFS)

DMARFS is used to store the Length/Type field of each incoming Ethernet packet. This is a “write clear” register and writing to the corresponding bit clears its value.

REGISTER	ADDRESS	R/W	DESCRIPTION	RESET VALUE
DMARFS	0xFFFF0_30C8	R/W	DMA Receive Frame Status Register	0x0000_0000

31	30	29	28	27	26	25	24
Reserved							
23	22	21	20	19	18	17	16
Reserved							
15	14	13	12	11	10	9	8
RXFLT							
7	6	5	4	3	2	1	0
RXFLT							

BITS	DESCRIPTIONS	
[31:16]	Reserved	
[15:0]	RXFLT	Receive Frame Length/Type stores the Length/Type field of each incoming Ethernet packet. If the bit EnDEN of MIEN is enabled and the Length/Type field of the incoming packet were received, the DENI bit of MISTA is set and triggers an interrupt. And, the contents of Length/Type field are stored in RXFLT.

Current Transmit Descriptor Start Address Register (CTXDSA)

CTXDSA stores the start address of the Tx descriptor that is currently used by the TxDMA. CTXDSA is read only and writing to this register has no effect.

REGISTER	ADDRESS	R/W	DESCRIPTION	RESET VALUE
CTXDSA	0xFFFF0_30CC	R	Current Transmit Descriptor Start Address Register	0x0000_0000



31	30	29	28	27	26	25	24
CTXDSA							
23	22	21	20	19	18	17	16
CTXDSA							
15	14	13	12	11	10	9	8
CTXDSA							
7	6	5	4	3	2	1	0
CTXDSA							

BITS	DESCRIPTIONS	
[31:0]	CTXDSA	Current Transmit Descriptor Start Address

Current Transmit Buffer Start Address Register (CTXBSA)

CTXDSA stores the start address of Tx frame buffer currently used by TxDMA. CTXBSA is read only and writing to this register has no effect.

REGISTER	ADDRESS	R/W	DESCRIPTION	RESET VALUE
CTXBSA	0xFFFF0_30D0	R	Current Transmit Buffer Start Address Register	0x0000_0000

31	30	29	28	27	26	25	24
CTXBSA							
23	22	21	20	19	18	17	16
CTXBSA							
15	14	13	12	11	10	9	8
CTXBSA							
7	6	5	4	3	2	1	0
CTXBSA							

BITS	DESCRIPTIONS	
[31:0]	CTXBSA	Current Transmit Buffer Start Address



Current Receive Descriptor Start Address Register (CRXD_SA)

CRXD_SA stores the start address of the Rx descriptor currently used by RxDMA. CRXD_SA is read only and writing to this register has no effect.

REGISTER	ADDRESS	R/W	DESCRIPTION	RESET VALUE
CRXD_SA	0xFFFF0_30D4	R	Current Receive Descriptor Start Address Register	0x0000_0000

31	30	29	28	27	26	25	24
CRXD_SA							
23	22	21	20	19	18	17	16
CRXD_SA							
15	14	13	12	11	10	9	8
CRXD_SA							
7	6	5	4	3	2	1	0
CRXD_SA							

BITS	DESCRIPTIONS	
[31:0]	CRXD_SA	Current Receive Descriptor Start Address

Current Receive Buffer Start Address Register (CRXB_SA)

The CRXB_SA stores the start address of Rx frame buffer currently used by RxDMA. The CRXB_SA is read only and writing to this register has no effect.

REGISTER	ADDRESS	R/W	DESCRIPTION	RESET VALUE
CRXB_SA	0xFFFF0_30D8	R	Current Receive Buffer Start Address Register	0x0000_0000

31	30	29	28	27	26	25	24
CRXB_SA							
23	22	21	20	19	18	17	16
CRXB_SA							
15	14	13	12	11	10	9	8
CRXB_SA							
7	6	5	4	3	2	1	0
CRXB_SA							



BITS	DESCRIPTIONS	
[31:0]	CRXBSA	Current Receive Buffer Start Address

Receive Finite State Machine Register (RXFSM)

RXFSM shows the current value of the FSM (Finite State Machine) of RxDMA and Rx FIFO controller. RXFSM is read only and writing to it has no effect. RXFSM is only used for debugging.

REGISTER	ADDRESS	R/W	DESCRIPTION	RESET VALUE
RXFSM	0xFFFF0_3200	R	Receive Finite State Machine Register	0x0081_1101

31	30	29	28	27	26	25	24
RX_FSM							
23	22	21	20	19	18	17	16
RX_FSM	Reserved	RxBuf_FSM					
15	14	13	12	11	10	9	8
RXFetch_FSM				RXClose_FSM			
7	6	5	4	3	2	1	0
RFF_FSM							

BITS	DESCRIPTIONS	
[31:23]	RX_FSM	RxDMA FSM
[22]	Reserved	-
[21:16]	RXBuf_FSM	Receive Buffer FSM
[15:12]	RXFetch_FSM	Receive Descriptor Fetch FSM
[11:8]	RXClose_FSM	Receive Descriptor Close FSM
[7:0]	RFF_FSM	RxFIFO Controller FSM



Transmit Finite State Machine Register (TXFSM)

TXFSM shows the current value of the FSM (Finite State Machine) of TxDMA and TxFIFO controller. The TXFSM is read only and writing to it has no effect. The TXFSM is only used for debugging.

REGISTER	ADDRESS	R/W	DESCRIPTION	RESET VALUE
TXFSM	0xFFFF0_3204	R	Transmit Finite State Machine Register	0x0101_1101

31	30	29	28	27	26	25	24
TX_FSM							
23	22	21	20	19	18	17	16
Reserved		TxBuf_FSM					
15	14	13	12	11	10	9	8
TXFetch_FSM				TXClose_FSM			
7	6	5	4	3	2	1	0
Reserved			TFF_FSM				

BITS	DESCRIPTIONS	
[31:24]	TX_FSM	TxDMA FSM
[23:22]	Reserved	-
[21:16]	TxBuf_FSM	Transmit Buffer FSM
[15:12]	TXFetch_FSM	Transmit Descriptor Fetch FSM
[11:8]	TXClose_FSM	Transmit Descriptor Close FSM
[7:5]	Reserved	-
[4:0]	TFF_FSM	TxFIFO Controller FSM

Finite State Machine Register 0 (FSM0)

FSM0 shows the current value of the FSM (Finite State Machine) in the EMC function module. FSM0 is read only and writing to it has no effect. The FSM0 is only used for debugging.

REGISTER	ADDRESS	R/W	DESCRIPTION	RESET VALUE
FSM0	0xFFFF0_3208	R	Finite State Machine Register 0	0x0001_0101



31	30	29	28	27	26	25	24
Reserved						TXMAC_FSM	
23	22	21	20	19	18	17	16
TXMAC_FSM							
15	14	13	12	11	10	9	8
Reserved		TXDefer_FSM					
7	6	5	4	3	2	1	0
STA_FSM							

BITS	DESCRIPTIONS	
[31:26]	Reserved	-
[25:16]	TXMAC_FSM	TxMAC FSM
[15:14]	Reserved	-
[13:8]	TXDefer_FSM	Transmit Defer Process FSM
[7:0]	STA_FSM	MII Management I/F FSM

Finite State Machine Register 1 (FSM1)

FSM1 shows the current value of the FSM (Finite State Machine) in the EMC function module. FSM1 is read only and writing to it has no effect. The FSM1 is only used for debugging.

Register	Address	R/W	Description	Reset Value
FSM1	0xFFFF0_320C	R	Finite State Machine Register 1	0x1100_0100

31	30	29	28	27	26	25	24
Reserved		ARB_FSM			TxPause_FSM		
23	22	21	20	19	18	17	16
Reserved							
15	14	13	12	11	10	9	8
Reserved		AHB_FSM					
7	6	5	4	3	2	1	0
Reserved							



BITS	DESCRIPTIONS	
[31]	Reserved	-
[30:28]	ARB_FSM	Internal Arbiter FSM
[27:24]	TxPause_FSM	Transmit PAUSE Control Frame FSM
[23:14]	Reserved	-
[13:8]	AHB_FSM	[13:8]: AHB Master FSM
[7:0]	Reserved	-

Debug Configuration Register (DCR)

DCR is for debugging only, to multiplex different signal groups. In FPGA emulation, signals are output to probe pins in an emulation board. In a real chip, the signals are output through the GPIO pins.

REGISTER	ADDRESS	R/W	DESCRIPTION	RESET VALUE
DCR	0xFFF0_3210	R/W	Debug Configuration Register	0x0000_003f

31	30	29	28	27	26	25	24
Reserved							
23	22	21	20	19	18	17	16
Enable		Reserved					
15	14	13	12	11	10	9	8
Reserved							
7	6	5	4	3	2	1	0
Out		Config					

BITS	DESCRIPTIONS	
[31:24]	Reserved	-
[23:22]	Enable	Enable outputs two function enable signals to external stimulus circuits. At this stage, only bit 22 is used for external random collision generation. The random collision generator is only used for FPGA emulation.
[21:8]	Reserved	-
[7:6]	Out	Flag Out provides two output flags to trigger Logic Analyzer for debugging. These two bits can be written at any time.
[5:0]	Config	The Configuration controls which group of internal signals can be multiplexed for debugging. Each group includes 16 signals.

W90P710CD/W90P710CDG



CONFIG	SIGNALS	CONFIG	SIGNALS
6'h00	OUT [6], TransDone, GrantLost, Trans_CTR [4:0], LAST, TransCtrExpire, DMode_AHB_CS [5:0]	6'h01	OUT [6], DMode_TxBuf_CS [6:0] DMode_TXFSM_CS [7:0]
6'h02	OUT [6], DMode_RXBuf_CS [5:0], DMode_RXFSM_CS [8:0]	6'h03	OUT [6], TXFIFO_HT, TXFIFO_LT, DMode_TFF_CS [4:0], DMode_RFF_CS [7:0]
6'h04	TxBuf_DRDY, TFF_WPTR [5:0], TX_START, TXSTART, READ, TFF_RPTR [5:0]	6'h05	WRITE, RFF_WPTR [5:0], RXFIFO_HT, RXFIFO_LT, RxBuf_ACK, RFF_RPTR [5:0]
6'h06	R0_PTLE, RxStart, SFD, WasSFD, RxFrame, WrByte, Rx_OvFlow, 1'b0, R0_RBC [7:0]	6'h07	R0_CRCE, RX_DV_In, SynStart, R0_DB, Rx_OvFlow, WRITECTR [2:0], RxByte [7:0]
6'h08	Reserved	6'h09	Reserved
6'h0A	OUT [7:6], RegMISTA_Rx_W, RXERR_sync, R0_CRCE, R0_PTLE, R0_RP, RegMISTA_Tx_W, T0_EXDEF, T0_TXABT, T0_CCNT [3:0], 2'b00	6'h0B	OUT [7:6], MCMDR_SDPZ_Clr, RegMCMDR_SDPZ_Clr, DMode_Pause_CS [3:0], MacCtlFra, PauseFra, PauseTx, MacCtlFra_sync, PauseFra_sync, PAUSE, Pause_en, FDUP
6'h0C	OUT [7:6], FrameWPtr [1:0], FrameRPtr [1:0], RFF_One, FrameWPtr_Inc, FrameRPtr_Inc, Rounding, NexPktStartPtr [5:0]	6'h0D	OUT [7:6], ARB_REQ_Set, ARB_REQ_Clr, DMode_ARB_CS [2:0], TransDone, GrantLost, TransCtrExpire, Trans_CTR [4:0], BURST
6'h0E	R0_CRCE, Rx_OvFlow, R0_MRE, CRCERR, DAMATCH, RxFrame, SFD, RxMIIErr, SynStart, Hi_Lo_Syn, New_DataValid, L_RxFrame, RxStart, DataValid, Hi_Lo, RX_DV_In	6'h0F	OUT [6], WRITE, RFF_WPTR [5:0], RxReuse, RxBuf_ACK, RFF_RPTR [5:0]
6'h10	WRITE, RFF_CS [7:1], RFF_WPTR [5:0], RXERR_sync, RxReuse	6'h11	OUT [6], TX_CLK, TX_EN, TXD [3:0], RX_CLK, RX_DV, RX_ER, RXD [3:0], CRS, COL



Continued

CONFIG	SIGNALS	CONFIG	SIGNALS
6'h12	OUT [6], TXSTART, TX_START, DMode_TFF_CS [4:0], TXSTART_Set, TXSTART_Clr, TXSTART_Re_Set, FrameWaiting, Deferring, COL, TXCOL, TXCOL_sync	6'h13	OUT [6], DMode_TxBuf_CS[6:0], DMode_TFF_CS[4:0], TXFIFO_UF, TXFIFO_HT, TXOK_sync
6'h14	OUT [6], READ, READ_sync, READ_Mask, ReadMask_sync, TFF_RPTR [5:0], DMode_TFF_CS [4:0]	6'h15	

Debug Mode MAC Information Register (DMMIR)

The DMMIR stores the information of MAC module for debug.

REGISTER	ADDRESS	R/W	DESCRIPTION	RESET VALUE
DMMIR	0xFFF0_3214	R	Debug Mode MAC Information Register	0x0000_0000

31	30	29	28	27	26	25	24
Reserved							
23	22	21	20	19	18	17	16
Reserved							
15	14	13	12	11	10	9	8
RBC							
7	6	5	4	3	2	1	0
RBC							

BITS	DESCRIPTIONS	
[31:16]	Reserved	-
[15:0]	RBC	Receive Byte Count



BIST Mode Register (BISTR)

BISTR controls the BIST (Built In Self Test) for embedded SRAM, 256B for Rx FIFO and 256B for Tx FIFO.

REGISTER	ADDRESS	R/W	DESCRIPTION	RESET VALUE
BISTR	0xFFFF0_3300	R/W	BIST Mode Register	0x0000_0000

31	30	29	28	27	26	25	24
Reserved							
23	22	21	20	19	18	17	16
Reserved							
15	14	13	12	11	10	9	8
Reserved							
7	6	5	4	3	2	1	0
Reserved				BistFail		Finish	BMEn

BITS	DESCRIPTIONS	
[31:5]	Reserved	-
[3:2]	BistFail	<p>BISTFail indicates if the BIST test failed or succeeded. If BistFail is low at the end the embedded SRAM passed the BIST test, otherwise it failed. BistFail goes high when the BIST detects the error and remains high during BIST operation. If BistFail[2] high indicates the embedded SRAM for Tx FIFO BIST test failed. If BistFail[3] high indicates the embedded SRAM for Rx FIFO BIST test failed.</p> <p>The BistFail is a "write clear field", and writing 1 to this field clears its contents; writing 0 has no effect.</p>
[1]	Finish	<p>BIST Operation Finish indicates the end of the BIST operation. When the BIST controller finishes all operations, this bit is high.</p> <p>The Finish is a "write clear" field, and writing 1 to this field clears the contents; writing 0 has no effect.</p>
[0]	BMEn	<p>BIST Mode Enable is used to enable BIST operation. If high, it enables the BIST controller to perform an embedded SRAM test. This bit is also used to reset the BIST circuit. It is necessary to reset the BIST circuit for at least one clock cycle in order to initialize the BIST properly.</p> <p>The BMEn can be disabled by writing 0.</p>



6.6 GDMA Controller

W90P710 has a two-channel general DMA controller, called the GDMA. The two-channel GDMA performs the following data transfers without the CPU intervention:

- Memory-to-memory (memory to/from memory)
- Memory –to – IO
- IO- to -memory

The on-chip GDMA can be started by the software or external DMA request nXDREQ. Software can also be used to restart the GDMA operation after it has been stopped. The CPU can recognize the completion of a GDMA operation by software polling or when it receives an internal GDMA interrupt. The W90P710 GDMA controller can increment source or destination address, decrement them as well, and conduct 8-bit (byte), 16-bit (half-word), or 32-bit (word) data transfers.

The GDMA includes the following features

- AMBA AHB compliant
- Supports 4-data burst mode to boost performance
- Provides support for external GDMA device
- Demand mode speeds up external GDMA operations

6.6.1 GDMA Functional Description

The GDMA directly transfers data between source and destination. The GDMA starts to transfer data after it receives service requests from nXDREQ signal or software. When the entire data has completely transferred, the GDMA becomes idle. Nevertheless, if another transfer is needed, then the GDMA must be programmed again. There are three transfer modes:

Single Mode

Single mode requires a GDMA request for each data transfer. A GDMA request (nXDREQ or software) causes one byte, one half-word, or one word to transfer if the 4-data burst mode is disabled, or four times of transfer width is the 4-data burst mode is enabled.

Block Mode

The assertion of a single GDMA request causes all of the data to be transferred in a single operation. The GDMA transfer is completed when the current transfer count register reaches zero.

Demand Mode

The GDMA continues transferring data until the GDMA request input nXDREQ becomes inactive.

W90P710CD/W90P710CDG



6.6.2 GDMA Register Map

R: read only, W: write only, R/W: both read and write, C: Only value 0 can be written

REGISTER	ADDRESS	R/W	DESCRIPTION	RESET VALUE
Channel 0				
GDMA_CTL0	0xFFF0_4000	R/W	Channel 0 Control Register	0x0000_0000
GDMA_SRCB0	0xFFF0_4004	R/W	Channel 0 Source Base Address Register	0x0000_0000
GDMA_DSTB0	0xFFF0_4008	R/W	Channel 0 Destination Base Address Register	0x0000_0000
GDMA_TCNT0	0xFFF0_400C	R/W	Channel 0 Transfer Count Register	0x0000_0000
GDMA_CSRC0	0xFFF0_4010	R	Channel 0 Current Source Address Register	0x0000_0000
GDMA_CDST0	0xFFF0_4014	R	Channel 0 Current Destination Address Register	0x0000_0000
GDMA_CTCNT0	0xFFF0_4018	R	Channel 0 Current Transfer Count Register	0x0000_0000
Channel 1				
GDMA_CTL1	0xFFF0_4020	R/W	Channel 1 Control Register	0x0000_0000
GDMA_SRCB1	0xFFF0_4024	R/W	Channel 1 Source Base Address Register	0x0000_0000
GDMA_DSTB1	0xFFF0_4028	R/W	Channel 1 Destination Base Address Register	0x0000_0000
GDMA_TCNT1	0xFFF0_402C	R/W	Channel 1 Transfer Count Register	0x0000_0000
GDMA_CSRC1	0xFFF0_4030	R	Channel 1 Current Source Address Register	0x0000_0000
GDMA_CDST1	0xFFF0_4034	R	Channel 1 Current Destination Address Register	0x0000_0000
GDMA_CTCNT1	0xFFF0_4038	R	Channel 1 Current Transfer Count Register	0x0000_0000

Channel 0/1 Control Register (GDMA_CTL0, GDMA_CTL1)

REGISTER	ADDRESS	R/W	DESCRIPTION	RESET VALUE
GDMA_CTL0	0xFFF0_4000	R/W	Channel 0 Control Register	0x0000_0000
GDMA_CTL1	0xFFF0_4020	R/W	Channel 1 Control Register	0x0000_0000

31	30	29	28	27	26	25	24
RESERVED	TC_WIDTH			REQ_SEL		REQ_ATV	ACK_ATV
23	22	21	20	19	18	17	16
RW_TC	SABNDERR	DABNDERR	GDMAERR	AUTOIEN	TC	BLOCK	SOFTREQ
15	14	13	12	11	10	9	8
DM	RESERVED	TWS		SBMS	RESERVE	BME	SIEN
7	6	5	4	3	2	1	0
SAFIX	DAFIX	SADIR	DADIR	GDMAMS		RESERVED	GDMAEN

W90P710CD/W90P710CDG



BITS	DESCRIPTIONS	
[31]	RESERVED	-
[30:28]	TC_WIDTH	nRTC/nWTC active width selection, from 1 to 7 HCLK cycles.
[27:26]	REQ_SEL	External request pin selection, if GDMAMS [3:2]=00, REQ_SEL is don't care. If REQ_SEL [27:26]=00, external request don't use. If REQ_SEL [27:26]=01, use nXDREQ. If REQ_SEL [27:26]=10, external request don't use. If REQ_SEL [27:26]=11, external request don't use.
[25]	REQ_ATV	nXDREQ High/Low active selection 1'b0 = nXDREQ is LOW active. 1'b1 = nXDREQ is HIGH active.
[24]	ACK_ATV	nXDACK High/Low active selection 1'b0 = nXDACK is LOW active. 1'b1 = nXDACK is HIGH active.
[23]	RW_TC	Read/Write terminal count output selection. 1'b0 = output to nRTC. 1'b1 = output to nWTC.
[22]	SABNDERR	Source address Boundary alignment Error flag If TWS [13:12]=10, GDMA_SRCB [1:0] should be 00 If TWS [13:12]=01, GDMA_SRCB [0] should be 0 The address boundary alignment should be depended on TWS [13:12]. 1'b0 = the GDMA_SRCB is on the boundary alignment. 1'b1 = the GDMA_SRCB not on the boundary alignment The SABNDERR register bits just can be read only.
[21]	DABNDERR	Destination address Boundary alignment Error flag If TWS [13:12]=10, GDMA_DSTB [1:0] should be 00 If TWS [13:12]=01, GDMA_DSTB [0] should be 0 The address boundary alignment should be depended on TWS [13:12]. 1'b0 = the GDMA_DSTB is on the boundary alignment. 1'b1 = the GDMA_DSTB not on the boundary alignment The DABNDERR register bits just can be read only.
[20]	GDMATERR	GDMA Transfer Error 1'b0 = No error occurs 1'b1 = Hardware sets this bit on a GDMA transfer failure Transfer error will generate GDMA interrupt



Continued

BITS	DESCRIPTIONS	
[19]	AUTOIEN	Auto initialization Enable 1'b0 = Disables auto initialization 1'b1 = Enables auto initialization, the GDMA_CSRC0/1, GDMA_CDST0/1, and GDMA_CTCNT0/1 registers are updated by the GDMA_SRC0/1, GDMA_DST0/1, and GDMA_TCNT0/1 registers automatically when transfer is complete.
[18]	TC	Terminal Count 1'b0 = Channel does not expire 1'b1 = Channel expires; this bit is set only by GDMA hardware, and clear by software to write logic 0. TC [18] is the GDMA interrupt flag. TC [18] or GDMATERR[20] will generate interrupt
[17]	BLOCK	Bus Lock 1'b0 = Unlocks the bus during the period of transfer 1'b1 = Locks the bus during the period of transfer
[16]	SOFTREQ	Software Triggered GDMA Request Software can request the GDMA transfer service by setting this bit to 1. This bit is automatically cleared by hardware when the transfer is completed. This bit is available only while GDMAMS [3:2] register bits are set on software mode (memory to memory).
[15]	DM	Demand Mode 1'b0 = Normal external GDMA mode 1'b1 = When this bit is set to 1, the external GDMA operation is sped up. When external GDMA device is operating in the demand mode, the GDMA transfers data as long as the external GDMA request signal nXDREQ is active. The amount of data transferred depends on how long the nXDREQ is active. When the nXDREQ is active and GDMA gets the bus in Demand mode, DMA holds the system bus until the nXDREQ signal becomes non-active. Therefore, the period of the active nXDREQ signal should be carefully tuned such that the entire operation does not exceed an acceptable interval (for example, during a DRAM refresh operation).
[14]	Reserved	-
[11]	SBMS	Single/Block Mode Select 1'b0 = Selects single mode. It requires an external GDMA request for every GDMA operation. 1'b1 = Selects block mode. It requires a single external GDMA request during the atomic GDMA operation. An atomic GDMA operation is defined as the sequence of GDMA operations until the transfer count register reaches zero.

W90P710CD/W90P710CDG



Continued

BITS	DESCRIPTIONS	
[10]	Reserved	-
[9]	BME	Burst Mode Enable 1'b0 = Disables the 4-data burst mode 1'b1 = Enables the 4-data burst mode FF there are 16 words to be transferred, and BME [9]=1, the GDMA_TCNT should be 0x04; However, if BME [9]=0, the GDMA_TCNT should be 0x10.
[8]	SIEN	Stop Interrupt Enable 1'b0 = Do not generate an interrupt when the GDMA operation is stopped 1'b1 = Interrupt is generated when the GDMA operation is stopped
[7]	SAFIX	Source Address Fixed 1'b0 = Source address is changed during GDMA operation 1'b1 = Destination address is not changed during GDMA operation. This feature can be used when data were transferred from a single source to multiple destinations.
[6]	DAFIX	Destination Address Fixed 1'b0 = Destination address is changed during GDMA operation 1'b1 = Destination address is not changed during GDMA operation. This feature can be used when data were transferred from multiple sources to a single destination.
[5]	SADIR	Source Address Direction 1'b0 = Source address is incremented successively 1'b1 = Source address is decremented successively
[4]	DADIR	Destination Address Direction 1'b0 = Destination address is incremented successively 1'b1 = Destination address is decremented successively
[3:2]	GDMAMS	GDMA Mode Select 00 = Software mode (memory-to-memory) 01 = External nXDREQ mode for external device 10 = Reserved 11 = Reserved
[1]	Reserved	-
[0]	GDMAEN	GDMA Enable 1'b0 = Disables GDMA operation 1'b1 = Enables GDMA operation; this bit is automatically cleared when the transfer is complete on AUTOIEN [19] register bit is on Disable mode.



Channel 0/1 Source Base Address Register (GDMA_SRCB0, GDMA_SRCB1)

GDMA channel starts reading its data from the source address as defined in this source base address register.

REGISTER	ADDRESS	R/W	DESCRIPTION	RESET VALUE
GDMA_SRCB0	0xFFF0_4004	R/W	Channel 0 Source Base Address Register	0x0000_0000
GDMA_SRCB1	0xFFF0_4024	R/W	Channel 1 Source Base Address Register	0x0000_0000

31	30	29	28	27	26	25	24
SRC_BASE_ADDR [31:24]							
23	22	21	20	19	18	17	16
SRC_BASE_ADDR [23:16]							
15	14	13	12	11	10	9	8
SRC_BASE_ADDR [15:8]							
7	6	5	4	3	2	1	0
SRC_BASE_ADDR [7:0]							

BITS	DESCRIPTIONS	
[31:0]	SRC_BASE_ADDR	32-bit Source Base Address

Channel 0/1 Destination Base Address Register (GDMA_DSTB0, DMA_DSTB1)

Channel 0/1 Destination Base Address Register (GDMA_DSTB0, GDMA_DSTB1)

GDMA channel starts writing its data to the destination address as defined in this destination base address register. During a block transfer, the GDMA determines successive destination addresses by adding to or subtracting from the destination base address.

REGISTER	ADDRESS	R/W	DESCRIPTION	RESET VALUE
GDMA_DSTB0	0xFFF0_4008	R/W	Channel 0 Destination Base Address Register	0x0000_0000
GDMA_DSTB1	0xFFF0_4028	R/W	Channel 1 Destination Base Address Register	0x0000_0000

31	30	29	28	27	26	25	24
DST_BASE_ADDR [31:24]							
23	22	21	20	19	18	17	16
DST_BASE_ADDR [23:16]							
15	14	13	12	11	10	9	8
DST_BASE_ADDR [15:8]							
7	6	5	4	3	2	1	0
DST_BASE_ADDR [7:0]							
BITS		DESCRIPTIONS					

W90P710CD/W90P710CDG



[31:0]	DST_BASE_ADDR	32-bit Destination Base Address
--------	---------------	---------------------------------

Channel 0/1 Transfer Count Register (GDMA_TCNT0, GDMA_TCNT1)

REGISTER	ADDRESS	R/W	DESCRIPTION	RESET VALUE
GDMA_TCNT0	0xFFF0_400C	R/W	Channel 0 Transfer Count Register	0x0000_0000
GDMA_TCNT1	0xFFF0_402C	R/W	Channel 1 Transfer Count Register	0x0000_0000

31	30	29	28	27	26	25	24
Reserved							
23	22	21	20	19	18	17	16
TFR_CNT [23:16]							
15	14	13	12	11	10	9	8
TFR_CNT [15:8]							
7	6	5	4	3	2	1	0
TFR_CNT [7:0]							

BITS	DESCRIPTIONS	
[31:24]	Reserved	-
[23:0]	TFR_CNT	TFR_CNT represents the required number of GDMA transfers. The maximum transfer count is 16M - 1.

Channel 0/1 Current Source Register (GDMA_CSRC0, GDMA_CSRC1)

REGISTER	ADDRESS	R/W	DESCRIPTION	RESET VALUE
GDMA_CSRC0	0xFFF0_4010	R	Channel 0 Current Source Address Register	0x0000_0000
GDMA_CSRC1	0xFFF0_4030	R	Channel 1 Current Source Address Register	0x0000_0000

31	30	29	28	27	26	25	24
CURRENT_SRC_ADDR [31:24]							
23	22	21	20	19	18	17	16
CURRENT_SRC_ADDR [23:16]							
15	14	13	12	11	10	9	8
CURRENT_SRC_ADDR [15:8]							
7	6	5	4	3	2	1	0
CURRENT_SRC_ADDR [7:0]							



BITS	DESCRIPTIONS	
[31:0]	CURRENT_SRC_ADDR	32-bit Current Source Address indicates the source address where the GDMA transfer occurred. During a block transfer, the GDMA determines successive source addresses by adding to or subtracting from the source base address. Depending on the settings you make to the control register, the current source address remains the same or is incremented or decremented.

Channel 0/1 Current Destination Register (GDMA_CDST0, GDMA_CDST1)

REGISTER	ADDRESS	R/W	DESCRIPTION	RESET VALUE
GDMA_CDST0	0xFFFF0_4014	R	Channel 0 Current Destination Address Register	0x0000_0000
GDMA_CDST1	0xFFFF0_4034	R	Channel 1 Current Destination Address Register	0x0000_0000

31	30	29	28	27	26	25	24
CURRENT_DST_ADDR [31:24]							
23	22	21	20	19	18	17	16
CURRENT_DST_ADDR [23:16]							
15	14	13	12	11	10	9	8
CURRENT_DST_ADDR [15:8]							
7	6	5	4	3	2	1	0
CURRENT_DST_ADDR [7:0]							

BITS	DESCRIPTIONS	
[31:0]	CURRENT_DST_ADDR	32-bit Current Destination Address indicates the destination address where the GDMA transfer occurred. During a block transfer, the GDMA determines successive destination addresses by adding to or subtracting from the destination base address. Depending on the settings you make to the control register, the current destination address will remain the same or is incremented or decremented.



Channel 0/1 Current Transfer Count Register (GDMA_CTCNT0/1)

Current transfer count register indicates the number of transfers being performed.

REGISTER	ADDRESS	R/W	DESCRIPTION	RESET VALUE
GDMA_CTCNT0	0xFFF0_4018	R	Channel 0 Current Transfer Count Register	0x0000_0000
GDMA_CTCNT1	0xFFF0_4038	R	Channel 1 Current Transfer Count Register	0x0000_0000

31	30	29	28	27	26	25	24
Reserved							
23	22	21	20	19	18	17	16
CURRENT_TFR_CNT [23:16]							
15	14	13	12	11	10	9	8
CURRENT_TFR_CNT [15:8]							
7	6	5	4	3	2	1	0
CURRENT_TFR_CNT [7:0]							

BITS	DESCRIPTIONS	
[31:24]	Reserved	-
[23:0]	CURRENT_TFR_CNT	Current Transfer Count register Current transfer count register indicates the number of transfers performed



6.7 USB Host Controller

The **Universal Serial Bus (USB)** is a low-cost, low-to-mid-speed peripheral interface standard intended for modems, scanners, PDAs, keyboards, mouse and other devices that do not require a high-bandwidth parallel interface. The USB is a 4-wire serial cable bus that supports serial data exchange between a Host Controller and a network of peripheral devices. The attached peripherals share USB bandwidth through a host-scheduled, token-based protocol. Peripherals may be attached, configured, used, and detached, while the host and other peripherals continue operation (i.e. hot plugging is supported).

A major design goal of the USB standard was to allow flexible, plug-and-play networks of USB devices. In any USB network, there is only one host, but there can be many devices and hubs.

The USB Host Controller has the following features:

- **Open Host Controller Interface (OHCI)** Revision 1.0 compatible.
- USB Revision 1.1 compatible
- Supports both low-speed (1.5 Mbps) and full-speed (12Mbps) USB devices.
- Handles all USB protocols.
- Built-in DMA for real-time data transfer
- Multiple low power modes for efficient power management

6.7.1 USB Host Functional Description

6.7.1.1 AHB Interface

The OpenHCI Host Controller is connected to the system by the AHB bus. The design requires both master and slave bus operations. As a master, the Host Controller is responsible for running cycles on the AHB bus to access EDs and TDs as well as transferring data between memory and the local data buffer. As a slave, the Host Controller monitors the cycles on the AHB bus and determines when to respond to these cycles. Configuration and non-real-time control access to the Host Controller operational registers are through the AHB bus slave interface.

6.7.1.2 Host Controller

List Processing

The List Processor manages the data structures from the Host Controller Driver and coordinates all activity within the Host Controller.

Frame Management

Frame Management is responsible for managing the frame specific tasks required by the USB specification and the OpenHCI specification. These tasks are:

- 1) Management of the OpenHCI frame specific Operational Registers
- 2) Operating the Largest Data Packet Counter.
- 3) Performing frame qualifications on USB Transaction requests to the SIE.
- 4) Generating SOF token requests to the SIE.

W90P710CD/W90P710CDG



Interrupt Processing

Interrupts are the communication method for HC-initiated communications with the Host Controller Driver. There are several events that may trigger an interrupt from the Host Controller. Each event sets a specific bit in the *HcInterruptStatus* register.

Host Controller Bus Master

The Host Controller Bus Master is the central block in the data path. The Host Controller Bus Master coordinates all access to the AHB Interface. There are two sources of bus mastering within Host Controller: the List Processor and the Data Buffer Engine.

Data Buffer

The Data Buffer serves as the data interface between the Bus Master and the SIE. It is a combination of a 64-byte latched based bi-directional asynchronous FIFO and a single Dword AHB Holding Register.

6.7.1.3 USB Interface

The USB interface includes the integrated Root Hub with two external ports, Port 1 and Port 2 as well as the Serial Interface Engine (SIE) and USB clock generator. The interface combines responsibility for executing bus transactions requested by the HC as well as the hub and port management specified by USB.

6.7.2 USB Host Controller Registers Map

REGISTER	ADDRESS	R/W	DESCRIPTION	RESET VALUE
OpenHCI Registers				
HcRevision	0xFFFF0_5000	R	Host Controller Revision Register	0x0000_0010
HcControl	0xFFFF0_5004	R/W	Host Controller Control Register	0x0000_0000
HcCommandStatus	0xFFFF0_5008	R/W	Host Controller Command Status Register	0x0000_0000
HcInterruptStatus	0xFFFF0_500C	R/W	Host Controller Interrupt Status Register	0x0000_0000
HcInterruptEnbale	0xFFFF0_5010	R/W	Host Controller Interrupt Enable Register	0x0000_0000
HcInterruptDisbale	0xFFFF0_5014	R/W	Host Controller Interrupt Disable Register	0x0000_0000
HcHCCA	0xFFFF0_5018	R/W	Host Controller Communication Area Register	0x0000_0000
HcPeriodCurrentED	0xFFFF0_501C	R/W	Host Controller Period Current ED Register	0x0000_0000
HcControlHeadED	0xFFFF0_5020	R/W	Host Controller Control Head ED Register	0x0000_0000
HcControlCurrentED	0xFFFF0_5024	R/W	Host Controller Control Current ED Register	0x0000_0000
HcBulkHeadEd	0xFFFF0_5028	R/W	Host Controller Bulk Head ED Register	0x0000_0000
HcBulkCurrentED	0xFFFF0_502C	R/W	Host Controller Bulk Current ED Register	0x0000_0000

W90P710CD/W90P710CDG



Continued.

REGISTER	ADDRESS	R/W	DESCRIPTION	RESET VALUE
OpenHCI Registers				
HcDoneHeadED	0xFFFF0_5030	R/W	Host Controller Done Head Register	0x0000_0000
HcFmInterval	0xFFFF0_5034	R/W	Host Controller Frame Interval Register	0x0000_2EDF
HcFrameRemaining	0xFFFF0_5038	R	Host Controller Frame Remaining Register	0x0000_0000
HcFmNumber	0xFFFF0_503C	R	Host Controller Frame Number Register	0x0000_0000
HcPeriodicStart	0xFFFF0_5040	R/W	Host Controller Periodic Start Register	0x0000_0000
HcLSThreshold	0xFFFF0_5044	R/W	Host Controller Low Speed Threshold Register	0x0000_0628
HcRhDescriptorA	0xFFFF0_5048	R/W	Host Controller Root Hub Descriptor A Register	0x0100_0002
HcRhDescriptorB	0xFFFF0_504C	R/W	Host Controller Root Hub Descriptor B Register	0x0000_0000
HcRhStatus	0xFFFF0_5050	R/W	Host Controller Root Hub Status Register	0x0000_0000
HcRhPortStatus [1]	0xFFFF0_5054	R/W	Host Controller Root Hub Port Status [1]	0x0000_0000
HcRhPortStatus [2]	0xFFFF0_5058	R/W	Host Controller Root Hub Port Status [2]	0x0000_0000
USB Configuration Registers				
TestModeEnable	0xFFFF0_5200	R/W	USB Test Mode Enable Register	0x0XXX_XXXX
OperationalModeEnable	0xFFFF0_5204	R/W	USB Operational Mode Enable Register	0x0000_0000



Host Controller Revision Register

REGISTER	OFFSET ADDRESS	R/W	DESCRIPTION	RESET VALUE
HcRevision	0xFFF0_5000	R	Host Controller Revision Register	0x0000_0010

31	30	29	28	27	26	25	24
Reserved							
23	22	21	20	19	18	17	16
Reserved							
15	14	13	12	11	10	9	8
Reserved							
7	6	5	4	3	2	1	0
Revision							

BITS		DESCRIPTION
[31:8]	Reserved	Reserved. Read/Write 0's
[7:0]	Revision	Indicates the Open HCI Specification revision number implemented by the Hardware. Host Controller supports 1.0 specification. (X.Y = XYh)

Host Controller Control Register

REGISTER	ADDRESS	R/W	DESCRIPTION	RESET VALUE
HcControl	0xFFF0_5004	R/W	Host Controller Control Register	0x0000_0000

31	30	29	28	27	26	25	24
Reserved							
23	22	21	20	19	18	17	16
Reserved							
15	14	13	12	11	10	9	8
Reserved					RWCE	RWC	IR
7	6	5	4	3	2	1	0
HCFS		BLE	CLE	ISE	PLE	CBR	

W90P710CD/W90P710CDG



BITS	DESCRIPTION	
[31:11]	Reserved	Reserved. Read/Write 0's
[10]	RWCE	RemoteWakeupConnectedEnable If a remote wakeup signal is supported, this bit enables that operation. Since there is no remote wakeup signal supported, this bit is ignored.
[9]	RWC	RemoteWakeupConnected This bit indicated whether the HC supports a remote wakeup signal. This implementation does not support any such signal. The bit is hard-coded as '0.'
[8]	INR	InterruptRouting This bit is used for interrupt routing: 0: Interrupts routed to normal interrupt mechanism (INT). 1: Interrupts routed to SMI.
[7:6]	HCFS	HostControllerFunctionalState This field sets the Host Controller state. The Controller may force a state change from USB SUSPEND to USB RESUME after detecting resume signals from a downstream port. States are: 00: USB RESET 01: USBRESUME 10: USBOPERATIONAL 11: USBSUSPEND
[5]	BLE	BulkListEnable When set, this bit enables processing of the Bulk list.
[4]	CLE	Control Listenable When set, this bit enables processing of the Control list.
[3]	ISE	Isochronous Enable When cleared, this bit disables the Isochronous List when the Periodic List is enabled (so Interrupt EDs may be serviced). While processing the Periodic List, the Host Controller will check this bit when it finds an isochronous ED.
[2]	PLE	Periodic Listenable When set, this bit enables processing of the Periodic (interrupt and isochronous) list. The Host Controller checks this bit prior to attempting any periodic transfers in a frame.
[1:0]	CBR	ControlBulkServiceRatio Specifies the number of Control Endpoints serviced for every Bulk Endpoint. Encoding is N-1 where N is the number of Control Endpoints (i.e. '00' = 1 Control Endpoint; '11' = 3 Control Endpoints)



Host Controller Command Status Register

REGISTER	ADDRESS	R/W	DESCRIPTION	RESET VALUE
HcCommandStatus	0xFFFO_5008	R/W	Host Controller Command Status Register	0x0000_0000

31	30	29	28	27	26	25	24
Reserved							
23	22	21	20	19	18	17	16
Reserved							
15	14	13	12	11	10	9	8
Reserved							
7	6	5	4	3	2	1	0
Reserved				OCR	BLF	CLF	HCR

BITS	DESCRIPTION	
[31:18]	Reserved	Reserved
[17:16]	SOC	ScheduleOverrunCount The field increments everytime the SchedulingOverrun bit in <i>HcInterruptStatus</i> is set. The count wraps from '11' to '00.'
[15:4]	Reserved	Reserved. Read/Write 0's
[3]	OCR	OwnershipChangeRequest When set by software, this bit sets the OwnershipChange field in <i>HcInterruptStatus</i> . The bit is cleared by software.
[2]	BLF	BulkListFilled Set to indicate there is an active ED on the Bulk List. The bit may be set by either software or the Host Controller and cleared by the Host Controller each time it begins processing the head of the Bulk List.
[1]	CLF	ControlListFilled Set to indicate there is an active ED on the Control List. It may be set by either software or the Host Controller and cleared by the Host Controller each time it begins processing the head of the Control List.
[0]	HCR	HostControllerReset This bit is set to initiate the software reset. This bit is cleared by the Host Controller, upon completion of the reset operation.



Host Controller Interrupt Status Register

All bits are set by hardware and cleared by software.

REGISTER	ADDRESS	R/W	DESCRIPTION	RESET VALUE
HcInterruptStatus	0xFFF0_500C	R/W	Host Controller Interrupt Status Register	0x0000_0000

31	30	29	28	27	26	25	24
Reserve	OCH	Reserved					
23	22	21	20	19	18	17	16
Reserved							
15	14	13	12	11	10	9	8
Reserved							
7	6	5	4	3	2	1	0
Reserve	RHSC	FNO	URE	RDT	SOF	WDH	SCO

BITS	DESCRIPTION	
[31]	Reserved	Reserved
[30]	OCH	OwnershipChange This bit is set when the OwnershipChangeRequest bit of <i>HcCommandStatus</i> is set.
[29:7]		Reserved
[6]	RHSC	RootHubStatusChange This bit is set when the content of <i>HcRhStatus</i> or the content of any <i>HcRhPortStatus</i> register has changed.
[5]	FNO	FrameNumberOverflow Set when bit 15 of FrameNumber changes value.
[4]	URE	UnrecoverableError This event is not implemented and is hard-coded to '0.' Writes are ignored.
[3]	RDT	ResumeDetected Set when Host Controller detects resume signaling on a downstream port.
[2]	SOF	StartOfFrame Set when the Frame Management block signals a 'Start of Frame' event.
[1]	WDH	WritebackDoneHead Set after the Host Controller has written <i>HcDoneHead</i> to <i>HccaDoneHead</i> .
[0]	SCHO	SchedulingOverrun Set when the List Processor determines a Schedule Overrun has occurred.



Host Controller Interrupt Enable Register

Writing 1 to a bit in this register sets the corresponding bit, while writing a 0 leaves the bit unchanged.

REGISTER	ADDRESS	R/W	DESCRIPTION	RESET VALUE
HcInterruptEnable	0xFFF0_5010	R/W	Host Controller Interrupt Enable Register	0x0000_0000

31	30	29	28	27	26	25	24
MIE	OCE	Reserved					
23	22	21	20	19	18	17	16
Reserved							
15	14	13	12	11	10	9	8
Reserved							
7	6	5	4	3	2	1	0
Reserved	RHCE	FNOE	UREE	RDTE	SOFE	WDHE	SCHOE

BITS	DESCRIPTION	
[31]	MIE	MasterInterruptEnable This bit is a global interrupt enable. Writing 1 allows interrupts to be enabled via the specific enable bits listed above.
[30]	OCE	OwnershipChangeEnable 0: Ignore 1: Enable interrupt generation due to Ownership Change.
[29:7]	Reserved	Reserved. Read/Write 0's
[6]	RHSCE	RootHubStatusChangeEnable 0: Ignore 1: Enable interrupt generation due to Root Hub Status Change.
[5]	FNOE	FrameNumberOverflowEnable 0: Ignore 1: Enable interrupt generation due to Frame Number Overflow.
[4]	UREE	UnrecoverableErrorEnable This event is not implemented. All writes to this bit are ignored.
[3]	RDTE	ResumeDetectedEnable 0: Ignore 1: Enable interrupt generation due to Resume Detected.
[2]	SOFE	StartOfFrameEnable 0: Ignore 1: Enable interrupt generation due to Start of Frame.
[1]	WDHE	WritebackDoneHeadEnable 0: Ignore 1: Enable interrupt generation due to Write-back Done Head.



Continued.

BITS		DESCRIPTION
[0]	SCHOE	SchedulingOverrunEnable 0: Ignore 1: Enable interrupt generation due to Scheduling Overrun.

Host Controller Interrupt Disable Register

Writing 1 to a bit in this register clears the corresponding bit, while writing 0 leaves that bit unchanged.

REGISTER	ADDRESS	R/W	DESCRIPTION	RESET VALUE
HcInterruptEnable	0xFFF0_5014	R/W	Host Controller Interrupt Disable Register	0x0000_0000

31	30	29	28	27	26	25	24
MIE	OCE	Reserved					
23	22	21	20	19	18	17	16
Reserved							
15	14	13	12	11	10	9	8
Reserved							
7	6	5	4	3	2	1	0
Reserved	RHSCE	FNOE	UREE	RDTE	SOFE	WDHE	SCHOE

BITS		DESCRIPTION
[31]	MIE	MasterInterruptEnable Global interrupt disable. Writing 1 disables all interrupts.
[30]	OCE	OwnershipChangeEnable 0: Ignore 1: Disable interrupt generation due to Ownership Change.
[29:7]	Reserved	Reserved. Read/Write 0's
[6]	RHSCE	RootHubStatusChangeEnable 0: Ignore 1: Disable interrupt generation due to Root Hub Status Change.
[5]	FNOE	FrameNumberOverflowEnable 0: Ignore 1: Disable interrupt generation due to Frame Number Overflow.

W90P710CD/W90P710CDG



Continued

BITS		DESCRIPTION
[4]	UREE	UnrecoverableErrorEnable This event is not implemented. All writes to this bit are ignored.
[3]	RDTE	ResumeDetectedEnable 0: Ignore 1: Disable interrupt generation due to Resume Detected.
[2]	SOFE	StartOfFrameEnable 0: Ignore 1: Disable interrupt generation due to Start of Frame.
[1]	WDHE	WritebackDoneHeadEnable 0: Ignore 1: Disable interrupt generation due to Write-back Done Head.
[0]	SCHOE	SchedulingOverrunEnable 0: Ignore 1: Disable interrupt generation due to Scheduling Overrun.

Host Controller Communication Area Register

REGISTER	ADDRESS	R/W	DESCRIPTION	RESET VALUE
HcHCCA	0xFFF0_5018	R/W	Host Controller Communication Area Register	0x0000_0000

31	30	29	28	27	26	25	24
HCCA							
23	22	21	20	19	18	17	16
HCCA							
15	14	13	12	11	10	9	8
HCCA							
7	6	5	4	3	2	1	0
Reserved							

BITS		DESCRIPTION
[31:8]	HCCA	HCCA Pointer to HCCA base address.
[7:0]	Reserved	Reserved



Host Controller Period Current ED Register

REGISTER	ADDRESS	R/W	DESCRIPTION	RESET VALUE
HcPeriodCurretED	0xFFF0_501C	R/W	Host Controller Period Current ED Register	0x0000_0000

31	30	29	28	27	26	25	24
PCED							
23	22	21	20	19	18	17	16
PCED							
15	14	13	12	11	10	9	8
PCED							
7	6	5	4	3	2	1	0
PCED							

BITS	DESCRIPTION	
[31:4]	PCED	PeriodCurrentED. Pointer to the current Periodic List ED.
[3:0]	Reserved	Reserved. Read/Write 0's

Host Controller Control Head ED Register

REGISTER	ADDRESS	R/W	DESCRIPTION	RESET VALUE
HcControlHeadED	0xFFF0_5020	R/W	Host Controller Control Head ED Register	0x0000_0000

31	30	29	28	27	26	25	24
CHED							
23	22	21	20	19	18	17	16
CHED							
15	14	13	12	11	10	9	8
CHED							
7	6	5	4	3	2	1	0
CHED				Reserved			

BITS	DESCRIPTION	
[31:4]	CHED	ControlHeadED Pointer to the Control List Head ED.
[3:0]	Reserved	Reserved

W90P710CD/W90P710CDG



Host Controller Control Current ED Register

REGISTER	OFFSET ADDRESS	R/W	DESCRIPTION	RESET VALUE
HcControlCurrentED	0xFFFF0_5024	R/W	Host Controller Control Current ED Register	0x0000_0000

31	30	29	28	27	26	25	24
CCED							
23	22	21	20	19	18	17	16
CCED							
15	14	13	12	11	10	9	8
CCED							
7	6	5	4	3	2	1	0
CCED				Reserved			

BITS	DESCRIPTION	
[31:4]	CCED	ControlCurrentED Pointer to the current Control List ED.
[3:0]	Reserved	Reserved. Read/Write 0's

Host Controller Bulk Head ED Register

REGISTER	OFFSET ADDRESS	R/W	DESCRIPTION	RESET VALUE
HcBulkHEADED	0xFFFF0_5028	R/W	Host Controller Bulk Head ED Register	0x0000_0000

31	30	29	28	27	26	25	24
BHED							
23	22	21	20	19	18	17	16
BHED							
15	14	13	12	11	10	9	8
BHED							
7	6	5	4	3	2	1	0
BHED				Reserved			

BITS	DESCRIPTION	
[31:4]	BHED	BulkHeadED. Pointer to the Bulk List Head ED.
[3:0]	Reserved	Reserved. Read/Write 0's



Host Controller Bulk Current ED Register

REGISTER	OFFSET ADDRESS	R/W	DESCRIPTION	RESET VALUE
HcBulkCurrentED	0xFFFF0_502C	R/W	Host Controller Bulk Current ED Register	0x0000_0000

31	30	29	28	27	26	25	24
BCED							
23	22	21	20	19	18	17	16
BCED							
15	14	13	12	11	10	9	8
BCED							
7	6	5	4	3	2	1	0
BCED				Reserved			

BITS	DESCRIPTION	
[31:4]	BCED	BulkCurrentED. Pointer to the current Bulk List ED.
[3:0]	Reserved	Reserved. Read/Write 0's

Host Controller Done Head Register

REGISTER	ADDRESS	R/W	DESCRIPTION	RESET VALUE
HcDoneHead	0xFFFF0_5030	R/W	Host Controller Done Head Register	0x0000_0000

31	30	29	28	27	26	25	24
DOHD							
23	22	21	20	19	18	17	16
DOHD							
15	14	13	12	11	10	9	8
DOHD							
7	6	5	4	3	2	1	0
DOHD				Reserved			

BITS	DESCRIPTION	
[31:4]	DOHD	DoneHead. Pointer to the current Done List Head ED.
[3:0]	Reserved	Reserved. Read/Write 0's



Host Controller Frame Interval Register

REGISTER	ADDRESS	R/W	DESCRIPTION	RESET VALUE
HcFmInterval	0xFFFF0_5034	R/W	Host Controller Frame Interval Register	0x0000_2ED F

31	30	29	28	27	26	25	24
FINTVT	FSLDP						
23	22	21	20	19	18	17	16
FSLDP							
15	14	13	12	11	10	9	8
Reserved		FINTV					
7	6	5	4	3	2	1	0
FINTV							

BITS	DESCRIPTION	
31	FINTVT	FrameIntervalToggle This bit is toggled by HCD when it loads a new value into Frame Interval .
[30:16]	FSLDP	FSLargestDataPacket This field specifies a value that is loaded into the Largest Data Packet Counter at the beginning of each frame.
[15:14]	Reserved	Reserved. Read/Write 0's
[13:0]	FINTV	Frame Interval This field specifies the length of a frame as (bit times - 1). For 12,000 bit times in a frame, a value of 11,999 is stored here.

Host Controller Frame Remaining Register

REGISTER	ADDRESS	R/W	DESCRIPTION	RESET VALUE
HcFmInterval	0xFFFF0_5038	R	Host Controller Frame Remaining Register	0x0000_0000

31	30	29	28	27	26	25	24
FRMT	Reserved						
23	22	21	20	19	18	17	16
Reserved							
15	14	13	12	11	10	9	8
Reserved		FRM					
7	6	5	4	3	2	1	0
FRM							

W90P710CD/W90P710CDG



BITS		DESCRIPTION
[31]	FRMT	FrameRemainingToggle Loaded with FrameIntervalToggle when Frame Remaining is loaded.
[30:14]	Reserved	Reserved. Read/Write 0's
[13:0]	FRM	Frame Remaining When the Host Controller is in the USBOPERATIONAL state, this 14-bit field decrements each 12 MHz clock period. When the count reaches 0, (end of frame) the counter reloads with Frame Interval . In addition, the counter loads when the Host Controller transitions into USBOPERATIONAL.

Host Controller Frame Number Register

REGISTER	ADDRESS	R/W	DESCRIPTION	RESET VALUE
HcFmNumber	0xFFFF0_503C	R	Host Controller Frame Number Register	0x0000_0000

31	30	29	28	27	26	25	24
Reserved							
23	22	21	20	19	18	17	16
Reserved							
15	14	13	12	11	10	9	8
FRMN							
7	6	5	4	3	2	1	0
FRMN							

BITS		DESCRIPTION
[31:16]	Reserved	Reserved. Read/Write 0's
[15:0]	FRMN	FrameNumber This 16-bit incrementing counter field is incremented with the loading of FrameRemaining . The count rolls over from 'FFFFh' to '0h.'

Host Controller Periodic Start Register

REGISTER	ADDRESS	R/W	DESCRIPTION	RESET VALUE
HcPeriodicStart	0xFFFF0_5040	R/W	Host Controller Periodic Start Register	0x0000_0000

W90P710CD/W90P710CDG



31	30	29	28	27	26	25	24
Reserved							
23	22	21	20	19	18	17	16
Reserved							
15	14	13	12	11	10	9	8
PERST							
7	6	5	4	3	2	1	0
PERST							

BITS	DESCRIPTION	
[31:14]	Reserved	Reserved. Read/Write 0's
[13:0]	PERST	PeriodicStart This field contains a value used by the List Processor to determine where in a frame the Periodic List processing must begin.

Host Controller Low Speed Threshold Register

REGISTER	ADDRESS	R/W	DESCRIPTION	RESET VALUE
HcLSThreshold	0xFFFF0_5044	R/W	Host Controller Low Speed Threshold Register	0x0000_0628

31	30	29	28	27	26	25	24
Reserved							
23	22	21	20	19	18	17	16
Reserved							
15	14	13	12	11	10	9	8
Reserved				LsThreshold			
7	6	5	4	3	2	1	0
LsTreshold							

BITS	DESCRIPTION	
[31:12]	Reserved	Rsvd. Read/Write 0's
[11:0]	LsTreshold	LSThreshold This field contains a value used by the Frame Management block to determine whether or not a low speed transaction can be started in the current frame.



Host Controller Root Hub Descriptor A Register

This register is only reset by a power-on reset. It is written during system initialization to configure the Root Hub. This bit should not be written during normal operation.

REGISTER	ADDRESS	R/W	DESCRIPTION	RESET VALUE
HcRhDescriptorA	0xFFFF0_5048	R/W	Host Controller Root Hub Descriptor A Register	0x0100.0002

31	30	29	28	27	26	25	24
POTPGT							
23	22	21	20	19	18	17	16
Reserved							
15	14	13	12	11	10	9	8
Reserved			OCPM	OCPM	DEVT	NPSW	PSWM
7	6	5	4	3	2	1	0
Reserved							

BITS	DESCRIPTION	
[31:24]	POTPGT	<p>PowerOnToPowerGoodTime</p> <p>This value is represented as the number of 2ms intervals to ensure power switching is effective within 2ms. Only bits [25:24] is implemented as R/W. The remaining bits are read only as 0. It is not expected that these bits be written to with anything other than 1h, but limited adjustment is provided. This field should be written to support system implementation. This field should always be written with a non-zero value.</p>
[23:13]	Reserved	Reserved. Read/Write 0's
[12]	NOCP	<p>NoOverCurrentProtection</p> <p>Global over-current reporting implemented in HYDRA-2. This bit should be written to support the external system port over-current implementation.</p> <p>0 = Over-current status is reported 1 = Over-current status is not reported</p>
[11]	OCPM	<p>OverCurrentProtectionMode</p> <p>Global over-current reporting implemented in HYDRA-2. This bit should be written 0 and is only valid when NoOverCurrentProtection is cleared.</p> <p>0 = Global Over-Current 1 = Individual Over-Current</p>
[10]	DEVT	<p>DeviceType</p> <p>table of none-4 is not a compound device.</p>
[9]	NPSW	<p>NoPowerSwitching</p> <p>Global power switching implemented in HYDRA-2. This bit should be written to support the external system port power switching implementation.</p> <p>0 = Ports are power switched. 1 = Ports are always powered on.</p>

W90P710CD/W90P710CDG



Continued

BITS		DESCRIPTION
[8]	PSWM	PowerSwitchingMode Global power switching mode implemented in HYDRA-2. This bit is only valid when NoPowerSwitching is cleared. This bit should be written 0. 0 = Global Switching 1 = Individual Switching
[7:0]	Reserved	Reserved

Host Controller Root Hub Descriptor B Register

This register is only reset by a power-on reset. It is written during system initialization to configure the Root Hub. These bits should not be written during normal operation.

REGISTER	ADDRESS	R/W	DESCRIPTION	RESET VALUE
HcRhDescriptorB	0xFFFF0_504C	R/W	Host Controller Root Hub Descriptor B Register	0x0000_0000

31	30	29	28	27	26	25	24
PPCM							
23	22	21	20	19	18	17	16
PPCM							
15	14	13	12	11	10	9	8
DEV RM							
7	6	5	4	3	2	1	0
DEV RM							

BITS		DESCRIPTION
[31:16]	PPCM	PortPowerControlMask Global-power switching. This field is only valid if NoPowerSwitching is cleared and PowerSwitchingMode is set (individual port switching). When set, the port only responds to individual port power switching commands (Set/ClearPortPower). When cleared, the port only responds to global power switching commands (Set/ClearGlobalPower). 0 = Device not removable 1 = Global-power mask Port Bit relationship - Unimplemented ports are reserved, read/write 0. 0 : Reserved 1 : Port 1 2 : Port 2 ... 15 : Port 15



Continued

BITS		DESCRIPTION
[15:0]	DEV RM	<p>DeviceRemoveable table of none-4 ports default to removable devices. 0 = Device not removable 1 = Device removable</p> <p>Port Bit relationship 0 : Reserved 1 : Port 1 2 : Port 2 ... 15 : Port 15</p> <p>Unimplemented ports are reserved, read/write 0.</p>

Host Controller Root Hub Status Register

This register is reset by the USBRESET state.

REGISTER	ADDRESS	R/W	DESCRIPTION	RESET VALUE
HcRhStstus	0xFFFF0_5050	R/W	Host Controller Root Hub Status Register	0x0000_0000

31	30	29	28	27	26	25	24
Reserved							
23	22	21	20	19	18	17	16
Reserved						OVIC	LPSC
15	14	13	12	11	10	9	8
DRWE	Reserved						
7	6	5	4	3	2	1	0
Reserved						OVRCI	LOPS

BITS		DESCRIPTION
[31]	CRWE	<p>(Write) ClearRemoteWakeupEnable Writing 1 to this bit clears DeviceRemoteWakeupEnable. Writing 1 has no effect.</p>
[30:18]	Reserved	Reserved. Read/Write 0's
[17]	OVIC	<p>OverCurrentIndicatorChange This bit is set when OverCurrentIndicator changes. Writing 1 clears this bit. Writing 0 has no effect.</p>

W90P710CD/W90P710CDG



Continued.

BITS		DESCRIPTION
[16]	LPSC	(Read) LocalPowerStatusChange Not supported. Always read 0. (Write) SetGlobalPower Write 1 issues a SetGlobalPower command to the ports. Writing a 0 has no effect.
[15]	DRWE	(Read) DeviceRemoteWakeupEnable This bit enables ports' ConnectStatusChange as a remote wakeup event. 0 = Disabled 1 = Enabled (Write) SetRemoteWakeupEnable Writing 1 sets DeviceRemoteWakeupEnable. Writing 0 has no effect.
[14:2]	Reserved	Reserved. Read/Write 0's
[1]	OVRCl	OverCurrentIndicator This bit reflects the state of the OVRCl pin. This field is only valid if NoOverCurrentProtection and OverCurrentProtectionMode are cleared. 0 = No over-current condition 1 = Over-current condition
[0]	LOPS	(Read) LocalPowerStatus Not Supported. Always reads 0. (Write) ClearGlobalPower Writing a 1 issues a ClearGlobalPower command to the ports. Writing a 0 has no effect.

Host Controller Root Hub Port Status [1][2]

This register is reset by the USBRESET state.

REGISTER	ADDRESS	R/W	DESCRIPTION	RESET VALUE
HcRhPortStatus [1]	0xFFF0_5054	R/W	Host Controller Root Hub Port Status [1]	0x0000_0000
HcRhPortStatus [2]	0xFFF0_5058	R/W	Host Controller Root Hub Port Status [2]	0x0000_0000

31	30	29	28	27	26	25	24
Reserved							
23	22	21	20	19	18	17	16
Reserved			PRSC	POCIC	PSSC	PESC	CSC
15	14	13	12	11	10	9	8
Reserved						LSDA	PPS
7	6	5	4	3	2	1	0
Reserved			SPR	CPS	SPS	SPE	DRM

W90P710CD/W90P710CDG



BITS	DESCRIPTION	
[31:21]	Reserved	Reserved. Read/Write 0's
[20]	PRSC	PortResetStatusChange This bit indicates that the port-reset signal is complete. 0 = Port reset is not complete. 1 = Port reset is complete.
[19]	POCIC	PortOverCurrentIndicatorChange This bit is set when OverCurrentIndicator changes. Writing 1 clears this bit. Writing a 0 has no effect.
[18]	PSSC	PortSuspendStatusChange This bit indicates the completion of the selective resume sequence for the port. 0 = Port is not resumed. 1 = Port resume is complete.
[17]	PESC	PortEnableStatusChange This bit indicates that the port has been disabled due to a hardware event (cleared PortEnableStatus). 0 = Port has not been disabled. 1 = PortEnableStatus has been cleared.
[16]	CSC	ConnectStatusChange This bit indicates connect or disconnect event has been detected. Writing 1 clears this bit. Writing 0 has no effect. 0 = No connect/disconnect event. 1 = Hardware detection of connect/disconnect event. Note: If DeviceRemoveable is set, this bit resets to 1.
[15:10]	Reserved	Reserved. Read/Write 0's
[9]	LSDA	(Read) LowSpeedDeviceAttached This bit defines the speed (and bud idle) of the attached device. It is only valid when CurrentConnectStatus is set. 0 = Full Speed device 1 = Low Speed device (Write) ClearPortPower Writing 1 clears PortPowerStatus . Writing a 0 has no effect
[8]	PPS	(Read) PortPowerStatus This bit reflects the power state of the port regardless of the power-switching mode. 0 = Port power is off. 1 = Port power is on. Note: If NoPowerSwitching is set, this bit is always read as 1. (Write) SetPortPower Writing 1 sets PortPowerStatus . Writing 0 has no effect.
[7:5]	Reserved	Reserved. Read/Write 0's

W90P710CD/W90P710CDG



Continued.

BITS	DESCRIPTION	
[4]	SPR	<p>(Read) PortResetStatus 0 = Port reset signal is not active. 1 = Port reset signal is active.</p> <p>(Write) SetPortReset Writing 1 sets PortResetStatus. Writing 0 has no effect.</p>
[3]	CPS	<p>(Read) PortOverCurrentIndicator table of none-2 supports global over-current reporting. This bit reflects the state of the OVRCUR pin dedicated to this port. This field is only valid if NoOverCurrentProtection is cleared and OverCurrentProtectionMode is set. 0 = No over-current condition 1 = Over-current condition</p> <p>(Write) ClearPortSuspend Writing 1 initiates the selective resume sequence for the port. Writing 0 has no effect.</p>
[2]	SPS	<p>(Read) PortSuspendStatus 0 = Port is not suspended 1 = Port is selectively suspended</p> <p>(Write) SetPortSuspend Writing 1 sets PortSuspendStatus. Writing 0 has no effect.</p>
[1]	SPE	<p>(Read) PortEnableStatus 0 = Port disabled. 1 = Port enabled.</p> <p>(Write) SetPortEnable Writing 1 sets PortEnableStatus. Writing 0 has no effect.</p>
[0]	DRM	<p>(Read) CurrentConnectStatus 0 = No device connected. 1 = Device connected.</p> <p>NOTE: If DeviceRemoveable is set (not removable) this bit is always 1.</p> <p>(Write) ClearPortEnable Writing 1 a clears PortEnableStatus. Writing 0 has no effect.</p>

USB Operational Mode Enable Register

This register selects which operational mode is enabled. Bits defined as write-only are read as 0's.

REGISTER	ADDRESS	R/W	DESCRIPTION	RESET VALUE
OperationalModeEnable	0xFFF0_5204	R/W	USB Operational Mode Enable Register	0x0000_0000

W90P710CD/W90P710CDG



31	30	29	28	27	26	25	24
Reserved							
23	22	21	20	19	18	17	16
Reserved							
15	14	13	12	11	10	9	8
Reserved							SIEPD
7	6	5	4	3	2	1	0
Reserved				OVRCUR	Reserved		DBREG

BITS		BIT DESCRIPTION
[31:9]	Reserved	Reserved. Read/write 0
[8]	SIEPD	SIE Pipeline Disable When set, waits for all USB bus activity to complete prior to returning completion status to the List Processor. This is a failsafe mechanism to avoid potential problems with the clk_dr transition between 1.5 MHz and 12 MHz.
[7:4]	Reserved	Reserved. Read/write 0
[3]	OVRCURP	OVRCURP (over current indicator polarity) When the OVRCURP bit is clear, the OVRCUR non-inverted to input into USB host controller. In contrast, when the OVRCURP bit is set, the OVRCUR inverted to input into USB host controller.
[2:1]	Reserved	Reserved. Read/write 0
[0]	DBREG	Data Buffer Region 16 When set, the size of the data buffer region is 16 bytes. Otherwise, the size is 32 bytes.

6.7.3 HCCA

6.7.4 Endpoint Descriptor

6.7.5 Transfer Descriptor

6.8 USB Device Controller

The USB controller interfaces the AHB bus and the USB bus. The USB controller contains both the AHB master interface and AHB slave interface. The CPU programs the USB controller through the AHB slave interface. For IN or OUT transfers, the USB controller needs to write data to memory or read data from memory through the AHB master interface. The USB controller also contains the USB transceiver to interface the USB.

W90P710CD/W90P710CDG



6.8.1 USB Endpoints

Consists of four endpoints, designated EP0, EPA, EPB and EPC. Each is intended for a particular use as described below:

EP0: the default endpoint uses control transfer (In/Out) to handle configuration and control functions required by the USB specification. Maximum packed size is 16 bytes.

EPA: designed as a general endpoint. This endpoint could be programmed to be an Interrupt IN endpoint or an Isochronous IN endpoint or a Bulk In endpoint or Bulk OUT endpoint.

EPB: designed as a general endpoint. This endpoint could be programmed to be an Interrupt IN endpoint or an Isochronous IN endpoint or a Bulk In endpoint or Bulk OUT endpoint.

EPC: designed as a general endpoint. This endpoint could be programmed to be an Interrupt IN endpoint or an Isochronous IN endpoint or a Bulk In endpoint or Bulk OUT endpoint.

6.8.2 Standard device request

USB controller has built-in hard-wired state machine to automatically respond to USB standard device requests. It also supports detecting class and vendor requests. For Get Descriptor request and Class or Vendor command, the firmware will control these procedures.

6.8.3 USB Device Register Description

USB Control Register (USB_CTL)

REGISTER	ADDRESS	R/W	DESCRIPTION	RESET VALUE
USB_CTL	0xFFFF0_6000	R/W	USB control register	0x0000_0000

31	30	29	28	27	26	25	24
Reserved							
23	22	21	20	19	18	17	16
Reserved							
15	14	13	12	11	10	9	8
Reserved							WakeUp
7	6	5	4	3	2	1	0
CCMD	VCMD	SIE_RCV	SUS_TST	RWU_EN	SUSP	USB_RST	USB_EN

W90P710CD/W90P710CDG



BITS	DESCRIPTIONS	
[31:9]		Reserved
[8]	WakeUp	0: no effect. 1: Generating remote wake-up signals to drive a K-state on the USB bus. This function brings the suspended USB bus to activation with the resume state.
[7]	CCMD	USB Class Command Decode Control Enable 0: Disable; the H/W circuit doesn't need to decode USB class command. It will return stall when it receives a USB Class Command. 1: Enable; the H/W circuit decodes USB class command. It will assert an interrupt event when it receives a USB Class Command.
[6]	VCMD	USB Vendor Command Decode Enable 0: Disable; the H/W circuit doesn't need to decode USB vendor command. It will return stall when it receives a USB Vendor Command. 1: Enable; the H/W circuit decodes USB vendor command. It will assert an interrupt event when it receives a USB Vendor Command.
[5]	SIE_RCV	USB SIE Differential RCV Source 0: RCV generated by the SIE 1: RCV generated by the USB transceiver
[4]	SUS_TST	USB Suspend Accelerate Test 0: Normal Operation 1: USB Suspend Accelerate Test (Only for Test)
[3]	RWU_EN	USB Remote Wake-up Enable 0: Disable USB Remote Wake-Up Detect 1: Enable USB Remote Wake-Up Detect
[2]	SUSP	USB Suspend Detect Enable 0: Disable USB Suspend Detect 1: Enable USB Suspend Detect
[1]	USB_RST	USB Engine Reset 0: Normal operation 1: Reset USB Engine
[0]	USB_EN	USB Engine Enable 0: disable USB Engine 1: enable USB Engine Note: set this bit to "0", the device is absent from host. After setting this bit to "1", the host will detect a device attached.

W90P710CD/W90P710CDG



USB Class or Vendor command Register (USB_CVCMD)

REGISTER	ADDRESS	R/W	DESCRIPTION	RESET VALUE
USB_CVCMD	0xFFFF0_6004	R/W	USB class or vendor command register	0x0000_0000

31	30	29	28	27	26	25	24
Reserved							
23	22	21	20	19	18	17	16
Reserved							
15	14	13	12	11	10	9	8
Reserved							
7	6	5	4	3	2	1	0
Reserved				CVI_LG			

BITS	DESCRIPTIONS	
[31:5]	-	Reserved
[4:0]	CVI_LG	Byte Length for Class and Vendor Command and Get Descriptor Return Data Packet

USB Interrupt Enable Register (USB_IE)

REGISTER	ADDRESS	R/W	DESCRIPTION	RESET VALUE
USB_IE	0xFFFF0_6008	R/W	USB interrupt enable register	0x0000_0000

31	30	29	28	27	26	25	24
Reserved							
23	22	21	20	19	18	17	16
Reserved							
15	14	13	12	11	10	9	8
RUM_CLKI	RST_ENDI	USB_CGI	USB_BTI	CVSI	CDII	CDOI	VENI
7	6	5	4	3	2	1	0
CLAI	GSTRI	GCFGI	GDEVI	ERRI	RUMI	SUSI	RSTI

W90P710CD/W90P710CDG



BITS	DESCRIPTIONS	
[31:16]	-	Reserved
[15]	RUM_CLKI	Interrupt enable for RESUME (if clock is stopped) 0: Disable 1: Enable
[14]	RST_ENDI	Interrupt enable for USB reset end 0: Disable 1: Enable
[13]	USB_CGI	Interrupt Enable for Device Configured 0: Disable 1: Enable Note: the interrupt occurs when the device configuration changes.
[12]	USB_BTI	Interrupt Enable for USB Bus Transition 0: Disable 1: Enable
[11]	CVSI	Interrupt Enable Control for Status Phase of Class or Vendor Command 0: Disable 1: Enable
[10]	CDII	Interrupt Enable Control for Data-In of Class or Vendor Command 0: Disable 1: Enable
[9]	CDOI	Interrupt Enable Control for Data-Out of Class or Vendor Command 0: Disable 1: Enable
[8]	VENI	Interrupt Enable Control for USB Vendor Command 0: Disable 1: Enable
[7]	CLAI	Interrupt Enable Control for USB Class Command 0: Disable 1: Enable
[6]	GSTRI	Interrupt Enable Control for USB Get_String_Descriptor Command 0: Disable 1: Enable

W90P710CD/W90P710CDG



Continued.

BITS		DESCRIPTIONS
[5]	GCFGI	Interrupt Enable Control for USB Get_Configuration_Descriptor Command 0: Disable 1: Enable
[4]	GDEVI	Interrupt Enable Control for USB Get_Device_Descriptor Command 0: Disable 1: Enable
[3]	ERRI	Interrupt Enable Control for USB Error Detect 0: Disable 1: Enable
[2]	RUMI	Interrupt Enable Control for USB Resume Detect 0: Disable 1: Enable
[1]	SUSI	Interrupt Enable Control for USB Suspend Detect 0: Disable 1: Enable
[0]	RSTI	Interrupt Enable Control for USB Reset Command Detect 0: Disable 1: Enable

USB Interrupt status Register (USB_IS)

REGISTER	ADDRESS	R/W	DESCRIPTION	RESET VALUE
USB_IS	0xFFFF6_000C	R	USB interrupt status register	0x0000_0000

31	30	29	28	27	26	25	24
Reserved							
23	22	21	20	19	18	17	16
Reserved							
15	14	13	12	11	10	9	8
RUM_CLKS	RSTENDS	USB_CGS	USB_BTSS	CVSS	CDIS	CDOS	VENS
7	6	5	4	3	2	1	0
CLAS	GSTRS	GCFGs	GDEVs	ERRS	RUMS	SUSS	RSTS

W90P710CD/W90P710CDG



BITS	DESCRIPTIONS	
[31:16]		Reserved
[15]	RUM_CLKS	Interrupt status for RESUME (if clock is stopped) 0: No Interrupt Generated 1: Interrupt Generated
[14]	RSTENDS	Interrupt status for USB reset end 0: No Interrupt Generated 1: Interrupt Generated
[13]	USB_CGS	Interrupt Status for USB Device Configured 0: No Interrupt Generated 1: Interrupt Generated (configuration changed)
[12]	USB_BTS	Interrupt Status for USB Bus Transition 0: No Interrupt Generated 1: Interrupt Generated
[11]	CVSS	Interrupt Status for Status Phase of Class or Vendor Command 0: No Interrupt Generated 1: Interrupt Generated
[10]	CDIS	Interrupt Status for Data-In of Class or Vendor Command 0: No Interrupt Generated 1: Interrupt Generated
[9]	CDOS	Interrupt Status for Data-Out of Class or Vendor Command 0: No Interrupt Generated 1: Interrupt Generated
[8]	VENS	Interrupt Status for USB Vendor Command 0: No Interrupt Generated 1: Interrupt Generated
[7]	CLAS	Interrupt Status for USB Class Command 0: No Interrupt Generated 1: Interrupt Generated



Continued.

BITS	DESCRIPTIONS	
[6]	GSTRS	Interrupt Status for USB Get_String_Descriptor Command 0: No Interrupt Generated 1: Interrupt Generated
[5]	GCFGCS	Interrupt Status for USB Get_Configuration_Descriptor Command 0: No Interrupt Generated 1: Interrupt Generated
[4]	GDEVS	Interrupt Status for USB Get_Device_Descriptor Command 0: No Interrupt Generated 1: Interrupt Generated
[3]	ERRS	Interrupt Status for USB Error Detected 0: No Interrupt Generated 1: Interrupt Generated
[2]	RUMS	Interrupt Status for USB Resume Detected 0: No Interrupt Generated 1: Interrupt Generated
[1]	SUSS	Interrupt Status for USB Suspend Detected 0: No Interrupt Generated 1: Interrupt Generated
[0]	RSTS	Interrupt Status for USB Reset Command Detected 0: No Interrupt Generated 1: Interrupt Generated

USB Interrupt Status Clear (USB_IC)

REGISTER	ADDRESS	R/W	DESCRIPTION	RESET VALUE
USB_IC	0xFFFF6_0010	R/W	USB interrupt status clear register	0x0000_0000

31	30	29	28	27	26	25	24
Reserved							
23	22	21	20	19	18	17	16
Reserved							
15	14	13	12	11	10	9	8
RUM_CLK C	RSTENDC	USB_CGC	USB_BTC	CVSC	CDIC	CDOC	VENC
7	6	5	4	3	2	1	0
CLAC	GSTRC	GCFGC	GDEVC	ERRC	RUMC	SUSC	RSTC

W90P710CD/W90P710CDG



BITS		DESCRIPTIONS
[31:16]		Reserved
[15]	RUM_CLK C	Interrupt status clear for RESUME (if clock is stopped) 0: NO Operation 1: Clear Interrupt Status
[14]	RSTENDC	Interrupt status clear for USB reset end 0: NO Operation 1: Clear Interrupt Status
[13]	USB_CGC	Interrupt Status Clear for USB Device Configured 0: NO Operation 1: Clear Interrupt Status
[12]	USB_BTC	Interrupt Status Clear for USB Bus Transition 0: NO Operation 1: Clear Interrupt Status
[11]	CVSC	Interrupt Status Clear for Status Phase of Class or Vendor Command 0: NO Operation 1: Clear Interrupt Status
[10]	CDIC	Interrupt Status Clear for Data-In of Class or Vendor Command 0: NO Operation 1: Clear Interrupt Status
[9]	CDOC	Interrupt Status Clear for Data-Out of Class or Vendor Command 0: NO Operation 1: Clear Interrupt Status
[8]	VENC	Interrupt Status Clear for USB Vendor Command 0: NO Operation 1: Clear Interrupt Status
[7]	CLAC	Interrupt Status Clear for USB Class Command 0: NO Operation 1: Clear Interrupt Status
[6]	GSTRC	Interrupt Status Clear for USB Get_String_Descriptor Command 0: NO Operation 1: Clear Interrupt Status

W90P710CD/W90P710CDG



Continued.

BITS		DESCRIPTIONS
[5]	GCFGC	Interrupt Status Clear for USB Get_Configuration_Descriptor Command 0: NO Operation 1: Clear Interrupt Status
[4]	GDEVC	Interrupt Status Clear for USB Get_Device_Descriptor Command 0: NO Operation 1: Clear Interrupt Status
[3]	ERRC	Interrupt Status Clear for USB Error Detected 0: NO Operation 1: Clear Interrupt Status
[2]	RUMC	Interrupt Status Clear for USB Resume Detected 0: NO Operation 1: Clear Interrupt Status
[1]	SUSC	Interrupt Status Clear for USB Suspend Detected 0: NO Operation 1: Clear Interrupt Status
[0]	RSTC	Interrupt Status Clear for USB Reset Command Detected 0: NO Operation 1: Clear Interrupt Status

USB Interface and String Register (USB_IFSTR)

REGISTER	ADDRESS	R/W	DESCRIPTION	RESET VALUE
USB_IFSTR	0xFFFF0_6014	R/W	USB interface and string register	0x0000_0000

31	30	29	28	27	26	25	24
Reserved							
23	22	21	20	19	18	17	16
Reserved							
15	14	13	12	11	10	9	8
Reserved						STR6_EN	STR5_EN
7	6	5	4	3	2	1	0
STR4_EN	STR3_EN	STR2_EN	STR1_EN	INF4_EN	INF3_EN	INF2_EN	INF1_EN

W90P710CD/W90P710CDG



BITS	DESCRIPTIONS	
[31:10]		Reserved
[9]	STR6_EN	USB String Descriptor-6 Control 0: Disable 1: Enable
[8]	STR5_EN	USB String Descriptor-5 Control 0: Disable 1: Enable
[7]	STR4_EN	USB String Descriptor-4 Control 0: Disable 1: Enable
[6]	STR3_EN	USB String Descriptor-3 Control 0: Disable 1: Enable
[5]	STR2_EN	USB String Descriptor-2 Control 0: Disable 1: Enable
[4]	STR1_EN	USB String Descriptor-1 Control 0: Disable 1: Enable
[3]	INF4_EN	USB Interface-4 Control 0: Disable 1: Enable
[2]	INF3_EN	USB Interface-3 Control 0: Disable 1: Enable
[1]	INF2_EN	USB Interface-2 Control 0: Disable 1: Enable
[0]	INF1_EN	USB Interface-1 Control 0: Disable 1: Enable

W90P710CD/W90P710CDG



USB Control transfer-out port 0 (USB_ODATA0)

REGISTER	ADDRESS	R/W	DESCRIPTION	RESET VALUE
USB_ODATA0	0xFFF0_6018	R	USB control transfer-out port 0 register	0x0000_0000

31	30	29	28	27	26	25	24
ODATA0							
23	22	21	20	19	18	17	16
ODATA0							
15	14	13	12	11	10	9	8
ODATA0							
7	6	5	4	3	2	1	0
ODATA0							

BITS	DESCRIPTIONS	
[31:0]	ODATA0	Control Transfer-out data 0

USB Control transfer-out port 1 (USB_ODATA1)

REGISTER	ADDRESS	R/W	DESCRIPTION	RESET VALUE
USB_ODATA1	0xFFF0_601C	R	USB control transfer-out port 1 register	0x0000_0000

31	30	29	28	27	26	25	24
ODATA1							
23	22	21	20	19	18	17	16
ODATA1							
15	14	13	12	11	10	9	8
ODATA1							
7	6	5	4	3	2	1	0
ODATA1							

BITS	DESCRIPTIONS	
[31:0]	ODATA1	Control Transfer-out data 1

USB Control transfer-out port 2 (USB_ODATA2)

REGISTER	ADDRESS	R/W	DESCRIPTION	RESET VALUE
USB_ODATA2	0xFFFF0_6020	R	USB control transfer-out port 2 register	0x0000_0000

31	30	29	28	27	26	25	24
ODATA2							
23	22	21	20	19	18	17	16
ODATA2							
15	14	13	12	11	10	9	8
ODATA2							
7	6	5	4	3	2	1	0
ODATA2							

BITS	DESCRIPTIONS	
[31:0]	ODATA2	Control Transfer-out data 2

USB Control transfer-out port 3 (USB_ODATA3)

REGISTER	ADDRESS	R/W	DESCRIPTION	RESET VALUE
USB_ODATA3	0xFFFF0_6024	R	USB control transfer-out port 3 register	0x0000_0000

31	30	29	28	27	26	25	24
ODATA3							
23	22	21	20	19	18	17	16
ODATA3							
15	14	13	12	11	10	9	8
ODATA3							
7	6	5	4	3	2	1	0
ODATA3							

BITS	DESCRIPTIONS	
[31:0]	ODATA3	Control Transfer-out data 3

USB Control transfer-in data port0 Register (USB_IDATA0)

REGISTER	ADDRESS	R/W	DESCRIPTION	RESET VALUE
USB_IDATA0	0xFFFF0_6028	R/W	USB transfer-in data port0 register	0x0000_0000

31	30	29	28	27	26	25	24
IDATA0							
23	22	21	20	19	18	17	16
IDATA0							
15	14	13	12	11	10	9	8
IDATA0							
7	6	5	4	3	2	1	0
IDATA0							

BITS	DESCRIPTIONS	
[31:6]	IDATA0	Control transfer-in data0

USB Control transfer-in data port 1 Register (USB_IDATA1)

REGISTER	ADDRESS	R/W	DESCRIPTION	RESET VALUE
USB_IDATA1	0xFFFF0_602C	R/W	USB control transfer-in data port 1	0x0000_0000

31	30	29	28	27	26	25	24
IDATA1							
23	22	21	20	19	18	17	16
IDATA1							
15	14	13	12	11	10	9	8
IDATA1							
7	6	5	4	3	2	1	0
IDATA1							

BITS	DESCRIPTIONS	
[31:6]	IDATA1	Control transfer-in data1

USB Control transfer-in data port 2 Register (USB_IDATA2)

REGISTER	ADDRESS	R/W	DESCRIPTION	RESET VALUE
USB_IDATA2	0xFFFF0_6030	R/W	USB control transfer-in data port 2	0x0000_0000

31	30	29	28	27	26	25	24
IDATA2							
23	22	21	20	19	18	17	16
IDATA2							
15	14	13	12	11	10	9	8
IDATA2							
7	6	5	4	3	2	1	0
IDATA2							

BITS	DESCRIPTIONS	
[31:6]	IDATA2	Control transfer-in data2

USB Control transfer-in data port 3 Register (USB_IDATA3)

REGISTER	ADDRESS	R/W	DESCRIPTION	RESET VALUE
USB_IDATA3	0xFFFF0_6034	R/W	USB control transfer-in data port 3	0x0000_0000

31	30	29	28	27	26	25	24
IDATA3							
23	22	21	20	19	18	17	16
IDATA3							
15	14	13	12	11	10	9	8
IDATA3							
7	6	5	4	3	2	1	0
IDATA3							

BITS	DESCRIPTIONS	
[31:6]	IDATA3	Control transfer-in data3

USB SIE Status Register (USB_SIE)

W90P710CD/W90P710CDG



REGISTER	ADDRESS	R/W	DESCRIPTION	RESET VALUE
USB_SIE	0xFFFF0_6038	R	USB SIE status Register	0x0000_0000

31	30	29	28	27	26	25	24
Reserved							
23	22	21	20	19	18	17	16
Reserved							
15	14	13	12	11	10	9	8
Reserved							
7	6	5	4	3	2	1	0
Reserved						USB_DPS	USB_DMS

BITS	DESCRIPTIONS	
[31:2]		Reserved
[1]	USB_DPS	USB Bus D+ Signal Status 0: USB Bus D+ Signal is low 1: USB Bus D+ Signal is high
[0]	USB_DMS	USB Bus D- Signal Status 0: USB Bus D- Signal is low 1: USB Bus D- Signal is high

USB Engine Register (USB_ENG)

REGISTER	ADDRESS	R/W	DESCRIPTION	RESET VALUE
USB_ENG	0xFFFF0_603C	R/W	USB Engine Register	0x0000_0000

31	30	29	28	27	26	25	24
Reserved							
23	22	21	20	19	18	17	16
Reserved							
15	14	13	12	11	10	9	8
Reserved							
7	6	5	4	3	2	1	0
Reserved				SDO_RD	CV_LDA	CV_STL	CV_DAT

W90P710CD/W90P710CDG



BITS	DESCRIPTIONS	
[31:4]	-	Reserved
[3]	SDO_RD	Setup or Bulk-Out Data Read Control 0: NO Operation 1: Read Setup or Bulk-Out Data from USB Host NOTE: this bit will auto clear after 32 HCLK
[2]	CV_LDA	USB Class and Vendor Command Last Data Packet Control 0: NO Operation 1: Last Data Packet for Data Input of Class and Vendor Command NOTE: this bit will auto clear after 32 HCLK
[1]	CV_STL	USB Class and Vendor Command Stall Control 0: NO Operation 1: Return Stall for Class and Vendor Command NOTE: this bit will auto clear after 32 HCLK
[0]	CV_DAT	USB Class and Vendor Command return data control 0: NO Operation 1: The Data Packet for Data Input of Class and Vendor Command or Get Descriptor command is ready. NOTE: this bit will auto clear after 32 HCLK

USB Control Register (USB_CTL5)

REGISTER	ADDRESS	R/W	DESCRIPTION	RESET VALUE
USB_CTL5	0xFFF0_6040	R	USB control transfer status register	0x0000_0000

31	30	29	28	27	26	25	24
Reserved							
23	22	21	20	19	18	17	16
Reserved							
15	14	13	12	11	10	9	8
CONF							
7	6	5	4	3	2	1	0
Reserved				CTRLPS			

ITS	DESCRIPTIONS
-----	--------------

W90P710CD/W90P710CDG



[31:16]		Reserved
[15:8]	CONF	USB configured value
[7:5]		Reserved
[4:0]	CTRLPS	Control transfer received packet size

USB Configured Value Register (USB_CONF0)

REGISTER	ADDRESS	R/W	DESCRIPTION	RESET VALUE
USB_CONF0	0xFFFF0_6044	R/W	USB Configured Value register	0x0000_0000

31	30	29	28	27	26	25	24
Reserved							
23	22	21	20	19	18	17	16
Reserved							
15	14	13	12	11	10	9	8
Reserved							
7	6	5	4	3	2	1	0
CONF0							

BITS	DESCRIPTIONS	
[31:8]		Reserved
[7:0]	CONF0	Software configured value

USB Endpoint A Information Register (EPA_INFO)

REGISTER	ADDRESS	R/W	DESCRIPTION	RESET VALUE
EPA_INFO	0xFFFF0_6048	R/W	USB endpoint A information register	0x0000_0000

31	30	29	28	27	26	25	24
Reserved	EPA_TYPE		EPA_DIR	Reserved		EPA_MPS	
23	22	21	20	19	18	17	16
EPA_MPS							
15	14	13	12	11	10	9	8
EPA_ALT				EPA_INF			
7	6	5	4	3	2	1	0
EPA_CFG				EPA_NUM			

W90P710CD/W90P710CDG



BITS		DESCRIPTIONS
[31]		Reserved
[30:29]	EPA_TYPE	Endpoint A type 00: reserved 01: bulk 10: interrupt 11: isochronous
[28]	EPA_DIR	Endpoint A direction 0: OUT 1: IN
[27:26]		Reserved
[25:16]	EPA_MPS	Endpoint A max. packet-size
[15:12]	EPA_ALT	Endpoint A alternative setting (READ ONLY)
[11:8]	EPA_INF	Endpoint A interface
[7:4]	EPA_CFG	Endpoint A configuration
[3:0]	EPA_NUM	Endpoint A number

USB Endpoint A Control Register (EPA_CTL)

REGISTER	ADDRESS	R/W	DESCRIPTION	RESET VALUE
EPA_CTL	0xFFFF0_604C	R/W	USB endpoint A control register	0x0000_0000

31	30	29	28	27	26	25	24
Reserved							
23	22	21	20	19	18	17	16
Reserved							
15	14	13	12	11	10	9	8
Reserved							
7	6	5	4	3	2	1	0
Reserved	EPA_ZERO	EPA_STL_CLR	EPA_THRE	EPA_STL	EPA_RDY	EPA_RST	EPA_EN

W90P710CD/W90P710CDG



BITS	DESCRIPTIONS	
[31:6]		Reserved
[6]	EPA_ZERO	Send zero length packet to HOST
[5]	EPA_STL_CLR	CLEAR the Endpoint A stall (WRITE ONLY)
[4]	EPA_THRE	Endpoint A threshold (only for ISO) 1: one-time available space in FIFO over 16 bytes, DMA accesses memory 0: one-time available space in FIFO over 32 bytes, DMA accesses memory
[3]	EPA_STL	Set the Endpoint A stall
[2]	EPA_RDY	The memory is ready for Endpoint A to access
[1]	EPA_RST	Endpoint A reset
[0]	EPA_EN	Endpoint A enable

USB Endpoint A interrupt enable Register (EPA_IE)

REGISTER	ADDRESS	R/W	DESCRIPTION	RESET VALUE
EPA_IE	0xFFF0_6050	R/W	USB endpoint A Interrupt Enable register	0x0000_0000

31	30	29	28	27	26	25	24
Reserved							
23	22	21	20	19	18	17	16
Reserved							
15	14	13	12	11	10	9	8
Reserved							
7	6	5	4	3	2	1	0
Reserved	EPA_CF_IE	EPA_BUS_ERR_IE	EPA_DMA_IE	EPA_ALT_IE	EPA_TK_IE	EPA_STL_IE	



BITS	DESCRIPTIONS	
[31:6]		Reserved
[5]	EPA_CF_IE	Endpoint A clear feature interrupt enable
[4]	EPA_BUS_ERR_IE	Endpoint A system bus error interrupt enable
[3]	EPA_DMA_IE	Endpoint A DMA transfer complete interrupt enable
[2]	EPA_ALT_IE	Endpoint A alternate setting interrupt enable
[1]	EPA_TK_IE	Endpoint A token input interrupt enable
[0]	EPA_STL_IE	Endpoint A stall interrupt enable

USB Endpoint A Interrupt Clear Register (EPA_IC)

REGISTER	ADDRESS	R/W	DESCRIPTION	RESET VALUE
EPA_IC	0xFFF0_6054	W	USB endpoint A interrupt clear register	0x0000_0000

31	30	29	28	27	26	25	24
Reserved							
23	22	21	20	19	18	17	16
Reserved							
15	14	13	12	11	10	9	8
Reserved							
7	6	5	4	3	2	1	0
Reserved		EPA_CF_IC	EPA_BUS_ERR_IC	EPA_DMA_IC	EPA_ALT_IC	EPA_TK_IC	EPA_STL_IC

BITS	DESCRIPTIONS	
[31:6]		Reserved
[5]	EPA_CF_INT_IC	Endpoint A clear feature interrupt clear
[4]	EPA_BUS_ERR_IC	Endpoint A system bus error interrupt clear
[3]	EPA_DMA_IC	Endpoint A DMA transfer complete interrupt clear
[2]	EPA_ALT_IC	Endpoint A alternate setting interrupt clear
[1]	EPA_TK_IC	Endpoint A token input interrupt clear
[0]	EPA_STL_IC	Endpoint A stall interrupt clear



USB Endpoint A Interrupt Status Register (EPA_IS)

REGISTER	ADDRESS	R/W	DESCRIPTION	RESET VALUE
EPA_IS	0xFFFF0_6058	R	USB endpoint A interrupt status register	0x0000_0000

31	30	29	28	27	26	25	24
Reserved							
23	22	21	20	19	18	17	16
Reserved							
15	14	13	12	11	10	9	8
Reserved							
7	6	5	4	3	2	1	0
Reserved		EPA_CF_IS	EPA_BUS_ERR_IS	EPA_DMA_IS	EPA_ALT_IS	EPA_TK_IS	EPA_STL_IS

BITS	DESCRIPTIONS	
[31:6]	Reserved	
[5]	EPA_CF_IS	Endpoint A clear feature interrupt status
[4]	EPA_BUS_ERR_IS	Endpoint A system bus error interrupt status
[3]	EPA_DMA_IS	Endpoint A DMA transfer complete interrupt status
[2]	EPA_ALT_IS	Endpoint A alternative setting interrupt status
[1]	EPA_TK_IS	Endpoint A token interrupt status
[0]	EPA_STL_IS	Endpoint A stall interrupt status

USB Endpoint A Address Register (EPA_ADDR)

REGISTER	ADDRESS	R/W	DESCRIPTION	RESET VALUE
EPA_ADDR	0xFFFF0_605C	R/W	USB endpoint A address register	0x0000_0000



31	30	29	28	27	26	25	24
EPA_ADDR							
23	22	21	20	19	18	17	16
EPA_ADDR							
15	14	13	12	11	10	9	8
EPA_ADDR							
7	6	5	4	3	2	1	0
EPA_ADDR							

BITS	DESCRIPTIONS	
[31:0]	EPA_ADDR	Endpoint A transfer address

USB Endpoint A transfer length Register (EPA_LENGTH)

REGISTER	ADDRESS	R/W	DESCRIPTION	RESET VALUE
EPA_LENGTH	0xFFFF0_6060	R/W	USB endpoint A transfer length register	0x0000_0000

31	30	29	28	27	26	25	24
Reserved							
23	22	21	20	19	18	17	16
Reserved				EPA_LENGTH			
15	14	13	12	11	10	9	8
EPA_LENGTH							
7	6	5	4	3	2	1	0
EPA_LENGTH							

BITS	DESCRIPTIONS	
[31:20]		Reserved
[19:0]	EPA_LENGTH	Endpoint A transfer length

USB Endpoint B Information Register (EPB_INFO)

REGISTER	ADDRESS	R/W	DESCRIPTION	RESET VALUE
EPB_INFO	0xFFFF0_6064	R/W	USB endpoint B information register	0x0000_0000

31	30	29	28	27	26	25	24
Reserved	EPB_TYPE		EPB_DIR	Reserved		EPB_MPS	
23	22	21	20	19	18	17	16
EPB_MPS							
15	14	13	12	11	10	9	8
EPB_ALT				EPB_INF			
7	6	5	4	3	2	1	0
EPB_CFG				EPB_NUM			

BITS	DESCRIPTIONS	
[31]	-	Reserved
[30:29]	EPB_TYPE	Endpoint B type 00: reserved 01: bulk 10: interrupt 11: isochronous
[28]	EPB_DIR	Endpoint B direction 0: OUT 1: IN
[27:26]	-	Reserved
[25:16]	EPB_MPS	Endpoint B max. packet-size
[15:12]	EPB_ALT	Endpoint B alternative setting (READ ONLY)
[11:8]	EPB_INF	Endpoint B interface
[7:4]	EPB_CFG	Endpoint B configuration
[3:0]	EPB_NUM	Endpoint B number

W90P710CD/W90P710CDG



USB Endpoint B Control Register (EPB_CTL)

REGISTER	ADDRESS	R/W	DESCRIPTION	RESET VALUE
EPB_CTL	0xFFFF0_6068	R/W	USB endpoint B control register	0x0000_0000

31	30	29	28	27	26	25	24
Reserved							
23	22	21	20	19	18	17	16
Reserved							
15	14	13	12	11	10	9	8
Reserved							
7	6	5	4	3	2	1	0
Reserved	EPB_ZERO	EPB_STL_CLR	EPB_THRE	EPB_STL	EPB_RDY	EPB_RST	EPB_EN

BITS	DESCRIPTIONS	
[31:7]	-	Reserved
[6]	EPB_ZERO	Send zero length packet back to HOST
[5]	EPB_STL_CLR	Clear the Endpoint B stall (WRITE ONLY)
[4]	EPB_THRE	Endpoint B threshold (only for ISO) 1: one-time available space in FIFO over 16 bytes, DMA accesses memory 0: one-time available space in FIFO over 32 bytes, DMA accesses memory
[3]	EPB_STL	Set the Endpoint B stall
[2]	EPB_RDY	The memory is ready for Endpoint B to access
[1]	EPB_RST	Endpoint B reset
[0]	EPB_EN	Endpoint B enable

USB Endpoint B interrupt enable Register (EPB_IE)

REGISTER	ADDRESS	R/W	DESCRIPTION	RESET VALUE
EPB_IE	0xFFFF0_606C	R/W	USB endpoint B Interrupt Enable register	0x0000_0000

W90P710CD/W90P710CDG



31	30	29	28	27	26	25	24
Reserved							
23	22	21	20	19	18	17	16
Reserved							
15	14	13	12	11	10	9	8
Reserved							
7	6	5	4	3	2	1	0
Reserved		EPB_CF_IE	EPB_BUS_ERR_IE	EPB_DMA_IE	EPB_ALT_IE	EPB_TK_IE	EPB_STL_IE

BITS	DESCRIPTIONS	
[31:6]		Reserved
[5]	EPB_CF_IE	Endpoint B clear feature interrupt enable
[4]	EPB_BUS_ERR_IE	Endpoint B system bus error interrupt enable
[3]	EPB_DMA_IE	Endpoint B DMA transfer complete interrupt enable
[2]	EPB_ALT_IE	Endpoint B alternate setting interrupt enable
[1]	EPB_TK_IE	Endpoint B token input interrupt enable
[0]	EPB_STL_IE	Endpoint B stall interrupt enable

USB Endpoint B Interrupt Clear Register (EPB_IC)

REGISTER	ADDRESS	R/W	DESCRIPTION	RESET VALUE
EPB_IC	0xFFFF0_6070	W	USB endpoint B interrupt clear register	0x0000_0000

31	30	29	28	27	26	25	24
Reserved							
23	22	21	20	19	18	17	16
Reserved							
15	14	13	12	11	10	9	8
Reserved							
7	6	5	4	3	2	1	0
Reserved		EPB_CF_IC	EPB_BUS_ERR_IC	EPB_DMA_IC	EPB_ALT_IC	EPB_TK_IC	EPB_STL_IC

W90P710CD/W90P710CDG



BITS	DESCRIPTIONS	
[31:6]	-	Reserved
[5]	EPB_CF_IC	Endpoint B clear feature interrupt clear
[4]	EPB_BUS_ERR_IC	Endpoint B system bus error interrupt clear
[3]	EPB_DMA_IC	Endpoint B DMA transfer complete interrupt clear
[2]	EPB_ALT_IC	Endpoint B alternate setting interrupt clear
[1]	EPB_TK_IC	Endpoint B token input interrupt clear
[0]	EPB_STL_IC	Endpoint B stall interrupt clear

USB Endpoint B Interrupt Status Register (EPB_IS)

REGISTER	ADDRESS	R/W	DESCRIPTION	RESET VALUE
EPB_IS	0xFFFF0_6074	R	USB endpoint B interrupt status register	0x0000_0000

31	30	29	28	27	26	25	24
Reserved							
23	22	21	20	19	18	17	16
Reserved							
15	14	13	12	11	10	9	8
Reserved							
7	6	5	4	3	2	1	0
Reserved	EPB_CF_IS	EPB_BUS_ERR_IS	EPB_DMA_IS	EPB_ALT_IS	EPB_TK_IS	EPB_STL_IS	

BITS	DESCRIPTIONS	
[31:6]	-	Reserved
[5]	EPB_CF_IS	Endpoint B clear feature interrupt status
[4]	EPB_DMA_IS	Endpoint B system bus error interrupt status
[3]	EPB_DMA_IS	Endpoint B DMA transfer complete interrupt status
[2]	EPB_ALT_IS	Endpoint B alternative setting interrupt status
[1]	EPB_TK_IS	Endpoint B token interrupt status
[0]	EPB_STL_IS	Endpoint B stall interrupt status



USB Endpoint B Address Register (EPB_ADDR)

REGISTER	ADDRESS	R/W	DESCRIPTION	RESET VALUE
EPB_ADDR	0xFFFF0_6078	R/W	USB endpoint B address register	0x0000_0000

31	30	29	28	27	26	25	24
EPB_ADDR							
23	22	21	20	19	18	17	16
EPB_ADDR							
15	14	13	12	11	10	9	8
EPB_ADDR							
7	6	5	4	3	2	1	0
EPB_ADDR							

BITS	DESCRIPTIONS	
[31:0]	EPB_ADDR	Endpoint B transfer address

USB Endpoint B transfer length Register (EPB_LENTH)

REGISTER	ADDRESS	R/W	DESCRIPTION	RESET VALUE
EPB_LENTH	0xFFFF0_607C	R/W	USB endpoint B transfer length register	0x0000_0000

31	30	29	28	27	26	25	24
Reserved							
23	22	21	20	19	18	17	16
Reserved				EPB_LENTH			
15	14	13	12	11	10	9	8
EPB_LENTH							
7	6	5	4	3	2	1	0
EPB_LENTH							

BITS	DESCRIPTIONS	
[31:20]		Reserved
[19:0]	EPB_LENTH	Endpoint B transfer length



USB Endpoint C Information Register (EPC_INFO)

REGISTER	ADDRESS	R/W	DESCRIPTION	RESET VALUE
EPC_INFO	0xFFFF0_6080	R/W	USB endpoint C information register	0x0000_0000

31	30	29	28	27	26	25	24
Reserved	EPC_TYPE		EPC_DIR	Reserved		EPC_MPS	
23	22	21	20	19	18	17	16
EPC_MPS							
15	14	13	12	11	10	9	8
EPC_ALT				EPC_INF			
7	6	5	4	3	2	1	0
EPC_CFG				EPC_NUM			

BITS	DESCRIPTIONS	
[31]		Reserved
[30:29]	EPC_TYPE	Endpoint C type 00: Reserved 01: Bulk 10: Interrupt 11: Isochronous
[28]	EPC_DIR	Endpoint C direction 0: OUT 1: IN
[27:26]		Reserved
[25:16]	EPC_MPS	Endpoint C max. packet-size
[15:12]	EPC_ALT	Endpoint C alternative setting (READ ONLY)
[11:8]	EPC_INF	Endpoint C interface
[7:4]	EPC_CFG	Endpoint C configuration
[3:0]	EPC_NUM	Endpoint C number



USB Endpoint C Control Register (EPC_CTL)

REGISTER	ADDRESS	R/W	DESCRIPTION	RESET VALUE
EPC_CTL	0xFFF0_6084	R/W	USB endpoint C control register	0x0000_0000

31	30	29	28	27	26	25	24
Reserved							
23	22	21	20	19	18	17	16
Reserved							
15	14	13	12	11	10	9	8
Reserved							
7	6	5	4	3	2	1	0
Reserved	EPC_ZERO	EPC_STL_CLR	EPC_THRE	EPC_STL	EPC_RDY	EPC_RST	EPC_EN

BITS	DESCRIPTIONS	
[31:7]		Reserved
[6]	EPC_ZERO	Send zero length packet back to HOST
[5]	EPC_STL_CLR	Clear the Endpoint C stall (WRITE ONLY)
[4]	EPC_THRE	Endpoint C threshold (only for ISO) 1: one-time available space in FIFO over 16 bytes, DMA access memory 0: one-time available space in FIFO over 32 bytes, DMA access memory
[3]	EPC_STL	Set the Endpoint C stall
[2]	EPC_RDY	The memory is ready for Endpoint C to access
[1]	EPC_RST	Endpoint C reset
[0]	EPC_EN	Endpoint C enable



USB Endpoint C interrupt enable Register (EPC_IE)

REGISTER	ADDRESS	R/W	DESCRIPTION	RESET VALUE
EPC_IE	0xFFFF0_6088	R/W	USB endpoint C Interrupt Enable register	0x0000_0000

31	30	29	28	27	26	25	24
Reserved							
23	22	21	20	19	18	17	16
Reserved							
15	14	13	12	11	10	9	8
Reserved							
7	6	5	4	3	2	1	0
Reserved	EPC_CF_IE	EPC_BUS_ERR_IE	EPC_DMA_IE	EPC_ALT_IE	EPC_TK_IE	EPC_STL_IE	

BITS	DESCRIPTIONS	
[31:6]		Reserved
[5]	EPC_CF_IE	Endpoint C clear feature interrupt enable
[4]	EPC_DMA_IE	Endpoint C system bus error interrupt enable
[3]	EPC_DMA_IE	Endpoint C DMA transfer complete interrupt enable
[2]	EPC_ALT_IE	Endpoint C alternate setting interrupt enable
[1]	EPC_TK_IE	Endpoint C token input interrupt enable
[0]	EPC_STL_IE	Endpoint C stall interrupt enable

USB Endpoint C Interrupt Clear Register (EPC_IC)

REGISTER	ADDRESS	R/W	DESCRIPTION	RESET VALUE
EPC_IC	0xFFFF0_608C	W	USB endpoint C interrupt clear register	0x0000_0000

W90P710CD/W90P710CDG



31	30	29	28	27	26	25	24
Reserved							
23	22	21	20	19	18	17	16
Reserved							
15	14	13	12	11	10	9	8
Reserved							
7	6	5	4	3	2	1	0
Reserved		EPC_CF_IC	EPC_BUS_ERR_IC	EPC_DMA_IC	EPC_ALT_IC	EPC_TK_IC	EPC_STL_IC

BITS	DESCRIPTIONS	
[31:6]		Reserved
[5]	EPC_CF_IC	Endpoint C clear feature interrupt clear
[4]	EPC_DMA_IC	Endpoint C system bus error interrupt clear
[3]	EPC_DMA_IC	Endpoint C DMA transfer complete interrupt clear
[2]	EPC_ALT_IC	Endpoint C alternate setting interrupt clear
[1]	EPC_TK_IC	Endpoint C token input interrupt clear
[0]	EPC_STL_IC	Endpoint C stall interrupt clear

USB Endpoint C Interrupt Status Register (EPC_IS)

REGISTER	ADDRESS	R/W	DESCRIPTION	RESET VALUE
EPC_IS	0xFFFF0_6090	R	USB endpoint C interrupt status register	0x0000_0000

31	30	29	28	27	26	25	24
Reserved							
23	22	21	20	19	18	17	16
Reserved							
15	14	13	12	11	10	9	8
Reserved							
7	6	5	4	3	2	1	0
Reserved		EPC_CF_IS	EPC_BUS_ERR_IS	EPC_DMA_IS	EPC_ALT_IS	EPC_TK_IS	EPC_STL_IS

W90P710CD/W90P710CDG



BITS	DESCRIPTIONS	
[31:6]		Reserved
[5]	EPC_CF_IS	Endpoint C clear feature interrupt status
[4]	EPC_BUS_ERR_IS	Endpoint A system bus error interrupt status
[3]	EPC_DMA_IS	Endpoint A DMA transfer complete interrupt status
[2]	EPC_ALT_IS	Endpoint A alternative setting interrupt status
[1]	EPC_TK_IS	Endpoint A token interrupt status
[0]	EPC_STL_IS	Endpoint A stall status

USB Endpoint C Address Register (EPC_ADDR)

REGISTER	ADDRESS	R/W	DESCRIPTION	RESET VALUE
EPC_ADDR	0xFFFF0_6094	R/W	USB endpoint C address register	0x0000_0000

31	30	29	28	27	26	25	24
EPC_ADDR							
23	22	21	20	19	18	17	16
EPC_ADDR							
15	14	13	12	11	10	9	8
EPC_ADDR							
7	6	5	4	3	2	1	0
EPC_ADDR							

BITS	DESCRIPTIONS	
[31:0]	EPC_ADDR	Endpoint C transfer address

USB Endpoint C transfer length Register (EPC_LENGTH)

REGISTER	ADDRESS	R/W	DESCRIPTION	RESET VALUE
EPC_LENGTH	0xFFFF0_6098	R/W	USB endpoint C transfer length register	0x0000_0000

W90P710CD/W90P710CDG



31	30	29	28	27	26	25	24
Reserved							
23	22	21	20	19	18	17	16
Reserved				EPC_LENTH			
15	14	13	12	11	10	9	8
EPC_LENTH							
7	6	5	4	3	2	1	0
EPC_LENTH							

BITS	DESCRIPTIONS	
[31:20]		Reserved
[19:0]	EPC_LENTH	Endpoint C transfer length

USB Endpoint A Remain transfer length Register (EPA_XFER)

REGISTER	ADDRESS	R/W	DESCRIPTION	RESET VALUE
EPA_XFER	0xFFF0_609C	R/W	USB endpoint A remaining transfer length register	0x0000_0000

31	30	29	28	27	26	25	24
Reserved							
23	22	21	20	19	18	17	16
Reserved				EPA_XFER			
15	14	13	12	11	10	9	8
EPA_XFER							
7	6	5	4	3	2	1	0
EPA_XFER							

BITS	DESCRIPTIONS	
[31:20]		Reserved
[19:0]	EPA_XFER	Endpoint A remaining transfer length

USB Endpoint A Remain packet length Register (EPA_PKT)

REGISTER	ADDRESS	R/W	DESCRIPTION	RESET VALUE
EPA_PKT	0xFFFF0_60A0	R/W	USB endpoint A remain packet length register	0x0000_0000

31	30	29	28	27	26	25	24
Reserved							
23	22	21	20	19	18	17	16
Reserved							
15	14	13	12	11	10	9	8
Reserved						EPA_PKT	
7	6	5	4	3	2	1	0
EPA_PKT							

BITS	Descriptions	
[31:10]		Reserved
[9:0]	EPA_PKT	Endpoint A remain packet length

USB Endpoint B Remain transfer length Register (EPB_XFER)

REGISTER	ADDRESS	R/W	DESCRIPTION	RESET VALUE
EPB_XFER	0xFFFF0_60A4	R/W	USB endpoint B remain transfer length register	0x0000_0000

31	30	29	28	27	26	25	24
Reserved							
23	22	21	20	19	18	17	16
Reserved				EPB_XFER			
15	14	13	12	11	10	9	8
EPB_XFER							
7	6	5	4	3	2	1	0
EPB_XFER							

BITS	DESCRIPTIONS	
[31:20]		Reserved
[19:0]	EPB_XFER	Endpoint B remain transfer length

USB Endpoint B Remain packet length Register (EPB_PKT)

REGISTER	ADDRESS	R/W	DESCRIPTION	RESET VALUE
EPB_PKT	0xFFFF0_60A8	R/W	USB endpoint B remain packet length register	0x0000_0000

31	30	29	28	27	26	25	24
Reserved							
23	22	21	20	19	18	17	16
Reserved							
15	14	13	12	11	10	9	8
Reserved						EPB_PKT	
7	6	5	4	3	2	1	0
EPB_PKT							

BITS	DESCRIPTIONS	
[31:10]		Reserved
[9:0]	EPB_PKT	Endpoint B remaining packet length

USB Endpoint C Remain transfer length Register (EPC_XFER)

REGISTER	ADDRESS	R/W	DESCRIPTION	RESET VALUE
EPC_XFER	0xFFFF0_60AC	R/W	USB endpoint C remaining transfer length register	0x0000_0000

31	30	29	28	27	26	25	24
Reserved							
23	22	21	20	19	18	17	16
Reserved				EPC_XFER			
15	14	13	12	11	10	9	8
EPC_XFER							
7	6	5	4	3	2	1	0
EPC_XFER							

W90P710CD/W90P710CDG



BITS	DESCRIPTIONS	
[31:20]		Reserved
[19:0]	EPC_XFER	Endpoint C remaining transfer length

USB Endpoint C Remain packet length Register (EPC_PKT)

REGISTER	ADDRESS	R/W	DESCRIPTION	RESET VALUE
EPC_PKT	0xFFFF0_60B0	R/W	USB endpoint C remaining packet length register	0x0000_0000

31	30	29	28	27	26	25	24
Reserved							
23	22	21	20	19	18	17	16
Reserved							
15	14	13	12	11	10	9	8
Reserved						EPC_PKT	
7	6	5	4	3	2	1	0
EPC_PKT							

BITS	DESCRIPTIONS	
[31:10]		Reserved
[9:0]	EPC_PKT	Endpoint C remaining packet length



6.9 SD Host Controller

The W90P710 SD host controller supports Secure Digital (SD, MMC) card devices. The SD host-controller also supports DMA functions to reduce the intervention of the CPU for data transfers between flash memory cards and system memory.

There are two 512B internal buffers embedded in the SD host controller to temporally buffer the data for DMA transfer between the flash memory card and system memory.

The SD host controller features are shown as below:

- Directly connect to Secure Digital (SD, MMC) flash memory card.
- Supports DMA function to accelerate the data transfer between the internal buffer, external SDRAM, and flash memory card.
- Two 512 bytes internal buffers are embedded inside of the SD host controller.
- No SPI mode.

6.9.1 Functional Description

SD host controller provides three signals, CLK, CMD and DAT[3:0], to all SD cards. CLK is a clock output signal. CMD and DAT[3:0] are bi-direction command and data signals, respectively.

The frequency of CLK is equal to $(\text{engine clock frequency})/(\text{SD_CLK}+1)$, where SD_CLK is the value of the SD clock control register. To save power, CLK is active only when there are activities between SD host controller and SD cards. Otherwise, CLK keeps inactive state (LOW).

According to the SD specification, the SD host controller provides several operations to communicate with SD Cards efficiently. The CPU writes to the SD access control register to setup operations.

When the command output enable bit of the SD access control register is set, SD host controller transfers a 48-bit command to one or more SD card. When the transfer is done, this bit is reset to 0 automatically.

For a 48-bits command, the 6-bits command number is coming from SD CMD code register and the 32-bits command argument is coming from SD command argument 1-4 registers. All other bits (including start bit, end bit and the CRC-7bits) are generated by SD host controller H/W circuit.

When the response input enable bit of the SD access control register is set, the SD host controller waits for a 48-bit response from one or more SD card. When a 48-bit response is received, this bit is automatically reset to 0.

The first 40 bits of the received response are stored into SD received response token1 – 5 registers.

The last 8 bits are CRC-7 bits and end bit. SD host controller H/W circuit checks CRC-7 and reports the result to SD status register.

When the data input enable bit of SD access control register is set, SD host controller waits for a block of data from a specific SD card. When a block of data is received, this bit is cleared to 0 automatically.

The received block of data is stored into the system memory and the address is starting from the address specified by S/W.

W90P710CD/W90P710CDG



SD host controller checks the associated CRC-16 bits and reports the result to SD status register.

If the data-input interrupt is enabled, an interrupt occurs when data transfer is finished. The data input status bit of SD status register is set as 1 for this interrupt. Thus, the CPU can identify a data-input interrupt by reading this bit.

When the data output enable bit of SD access control register is set, SD host controller transfers a block of data to a specific MMC card. When the data transfer is finished, this bit is cleared to 0 automatically.

Before the data is transferred, the data to be transmitted must be stored into system memory and the S/W must specify the starting address where the data is stored.

SD host controller will generate the associated CRC-16 bits itself. After the data is transmitted, it also checks the CRC-status response from the SD card. The result is stored into the SD status register.

If the data-output interrupt is enabled, an interrupt will occur when the data transfer is finished. The data output status bit of the SD status register is set to 1 for this interrupt. Thus, the CPU can identify a data-output interrupt by reading this bit.

1. When the response R2 input enable bit of SD access control register is set, SD host controller transfers a block of data to a specific SD card. When the data transfer is finished and this bit is set, the SD host controller waits for a 136-bit R2 response from the SD card. When the R2 response is completely received, the bit is reset to 0 automatically.
 - The received data of R2 response token (136-bit) is stored into the system memory, starting from the address specified by software.
 - SD host controller checks the CRC-7 and reports the result to SD status register.
2. When the 74-clock cycles output enable bit of SD access control register is set, SD host controller generates 74 clock cycles without any CMD or DAT activity. After the 74 clock cycles have been generated, the bit is reset to 0 automatically.



6.9.2 Register Mapping

REGISTER	ADDRESS	R/W	DESCRIPTION	RESET VALUE
SD Registers (6)				
SDGCR	0xFFFF0_0000	R/W	SD Global Control Register	0x0000_0000
SDDSA	0xFFFF0_0004	R/W	SD DMA Transfer Starting Address Register	0x0000_0000
SDBCR	0xFFFF0_7008	R/W	SD DMA Byte Count Register	0x0000_0000
SDGIER	0xFFFF0_700C	R/W	SD Global Interrupt Enable Register	0x0000_0000
SDGISR	0xFFFF0_7010	R/W	SD Global Interrupt Status Register	0x0000_0000
SDBIST	0xFFFF0_7014	R/W	SD BIST Register	0x0000_0000
Secure Digital Registers (8)				
SDICR	0xFFFF0_7300	R/W	SD Interface Control Register	0x0000_0000
SDHIIR	0xFFFF0_7304	R/W	SD Host Interface Initial Register	0x0000_0018
SDIIER	0xFFFF0_7308	R/W	SD Interface Interrupt Enable Register	0x0000_0000
SDIISR	0xFFFF0_730C	R/W	SD Interface Interrupt Status Register	0x0000_00XX
SDAUG	0xFFFF0_7310	R/W	SD Command Argument Register	0x0000_0000
SDRSP0	0xFFFF0_7314	R	SD Receive Response Token Register 0	0xFFFF_XXXX
SDRSP1	0xFFFF0_7318	R	SD Receive Response Token Register 1	0x0000_XXXX
SDBLEN	0xFFFF0_731C	R/W	SD Block Length Register	0x0000_0000
Internal Buffer Access Register (256)				
FB0_0	0xFFFF0_7400	R/W	Flash Buffer 0	Undefined
.....			
FB0_127	0xFFFF0_75FC			
FB1_0	0xFFFF0_7800	R/W	Flash Buffer 1	Undefined
.....			
FB1_127	0xFFFF0_79FC			



6.9.3 SD Register Description

SD Global Control Register (SDGCR)

REGISTER	ADDRESS	R/W	DESCRIPTION	RESET VALUE
SDGCR	0xFFFF0_7000	R/W	SD Global Control Register	0x0000_0000

31	30	29	28	27	26	25	24
Reserved							
23	22	21	20	19	18	17	16
Reserved							
15	14	13	12	11	10	9	8
Reserved				RdSel			
7	6	5	4	3	2	1	0
Reserved	WrSel			DMARd	DMAWr	SWRST	SDEN

BITS	DESCRIPTIONS	
[31:11]	Reserved	-
[10:8]	RdSel	<p>Read Select</p> <p>This field indicates which of DMA or SD host controller can read data from buffer 0 or buffer 1.</p> <p>3'b000: DMA can read buffer 0 (Default)</p> <p>3'b011: SD host controller can read buffer 0</p> <p>3'b100: DMA can read buffer 1</p> <p>3'b111: SD host controller can read buffer 1</p>
[6:4]	WrSel	<p>Write Select</p> <p>This field indicates which of DMA, SD host controller can write data into buffer 0 or buffer 1.</p> <p>3'b000: DMA can write buffer 0 (Default)</p> <p>3'b011: SD host controller can write buffer 0</p> <p>3'b100: DMA can write buffer 1</p> <p>3'b111: SD host controller can write buffer 1</p>
[2]	DMAWr	<p>DMA Write Enable</p> <p>Setting this bit high enables the DMA to transfer data from internal buffer into external SDRAM. This bit is automatically cleared after the DMA operation has finished. Writing 0 to this bit has no effect.</p> <p>1'b0: No DMA operation (Default)</p> <p>1'b1: Enable DMA write operation</p>



Continued.

BITS		DESCRIPTIONS
[1]	SWRST	Software Reset Setting this bit high only resets the logic circuit of the SD host controller and has no effect on all control registers. 1'b0: No operation (Default) 1'b1: Enable software reset
[0]	SDEN	SD Function Enable Setting this bit high enables SD host controller operation. If this bit is cleared, all operations are disabled and the SD host controller only responds to control register access. 1'b0: Disable SD host controller (Default) 1'b1: Enable SD host controller

SD DMA Transfer Starting Address Register (SDDSA)

REGISTER	ADDRESS	R/W	DESCRIPTION	RESET VALUE
SDDSA	0xFFFF0_7004	R/W	SD DMA Transfer Starting Address Register	0x0000_0000

31	30	29	28	27	26	25	24
DMA							
23	22	21	20	19	18	17	16
DMA							
15	14	13	12	11	10	9	8
DMA							
7	6	5	4	3	2	1	0
DMA							

BITS		DESCRIPTIONS
[31:0]	DMA	DMA Transfer Starting Address This field defines the address of external SDRAM where DMA reads/writes data from/to.

SD DMA Byte Count Register (SDBCR)

REGISTER	ADDRESS	R/W	DESCRIPTION	RESET VALUE
SDBCR	0xFFFF0_7008	R/W	SD DMA Byte Count Register	0x0000_0000

W90P710CD/W90P710CDG



31	30	29	28	27	26	25	24
Reserved							
23	22	21	20	19	18	17	16
Reserved							
15	14	13	12	11	10	9	8
Reserved				BCNT			
7	6	5	4	3	2	1	0
BCNT							

BITS	DESCRIPTIONS	
[31:12]	Reserved	-
[11:0]	BCNT	DMA Transfer Byte Count This field defines the byte count of DMA Transfer between internal flash buffer and external SDRAM.

SD Global Interrupt Enable Register (SDGIER)

REGISTER	ADDRESS	R/W	DESCRIPTION	RESET VALUE
SDGIER	0xFFFF0_700C	R/W	SD Global Interrupt Enable Register	0x0000_0000

31	30	29	28	27	26	25	24
Reserved							
23	22	21	20	19	18	17	16
Reserved							
15	14	13	12	11	10	9	8
Reserved							
7	6	5	4	3	2	1	0
Reserved	ERRIEN	DRdIEN	DWRIEN	SDHIEN	Reserved	Reserved	SDGIEN

BITS	DESCRIPTIONS	
[31:7]	Reserved	-
[6]	ERRIEN	Bus Error Interrupt Enable

W90P710CD/W90P710CDG



Continued

BITS		DESCRIPTIONS
[5]	DRdIEN	DMA Read Interrupt Enable This bit controls the SD host controller interrupt generation from the interrupt of the DMA read operation. 1'b0: DMA read interrupt is masked from SD host controller interrupt generation 1'b1: DMA read interrupt can participate in SD host controller interrupt generation
[4]	DWwIEN	DMA Write Interrupt Enable This bit controls the SD host controller interrupt generation from the interrupt of the DMA write operation. 1'b0: DMA write interrupt is masked from SD host controller interrupt generation 1'b1: DMA write interrupt can participate in SD host controller interrupt generation
[3]	SDHIEN	Secure Digital Host Controller Interface Interrupt Enable This bit controls the SD host controller interrupt generation from the interrupt of Secure Digital host controller. 1'b0: Secure Digital host controller's interrupt is masked from SD host controller interrupt generation 1'b1: Secure Digital host controller's interrupt can participate in SD host controller interrupt generation
[0]	SDGIEN	SD Host Global Interrupt Enable This bit controls the global interrupt generation of SD host controller. 1'b0: Disable SDI host controller global interrupt generation 1'b1: Enable SD host controller global interrupt generation

SD Global Interrupt Status Register (SDGISR)

REGISTER	ADDRESS	R/W	DESCRIPTION	RESET VALUE
SDGISR	0xFFF0_7010	R/W	SD Global Interrupt Status Register	0x0000_0000

31	30	29	28	27	26	25	24
Reserved							
23	22	21	20	19	18	17	16
Reserved							
15	14	13	12	11	10	9	8
Reserved							
7	6	5	4	3	2	1	0
Reserved	ERRINT	DRdINT	DWwINT	SDHIINT	Reserved	Reserved	SDGINT



BITS	DESCRIPTIONS	
[31:7]	Reserved	-
[6]	ERRINT	Bus Error Interrupt Status
[5]	DRdINT	DMA Read Interrupt Status This bit indicates the DMA read transfer (from external SDRAM to internal buffer) has finished. 1'b0: No DMA read transfer completion 1'b1: DMA read transfer completed
[4]	DWrINT	DMA Write Interrupt Status This bit indicates the DMA write transfer (from internal buffer to external SDRAM) has finished. 1'b0: No DMA write transfer completion 1'b1: DMA write transfer completed
[3]	SDHIINT	Secure Digital Host Controller Interface Interrupt Status This bit indicates there is an interrupt status from Secure Digital host controller. 1'b0: No interrupt status from Secure Digital host controller interface. 1'b1: There is an interrupt status from Secure Digital host controller Interface
[0]	SDGINT	SD Host Global Interrupt Status This bit is the wired-OR of SDHIINT, DWrINT and DRdINT. 1'b0: No SD host controller interrupt notification 1'b1: There is an SD host controller interrupt status

SD BIST Register (SDBIST)

REGISTER	ADDRESS	R/W	DESCRIPTION	RESET VALUE
SDBIST	0xFF0_7014	R/W	SD BIST Register	0x0000_0000

31	30	29	28	27	26	25	24
Reserved							
23	22	21	20	19	18	17	16
Reserved							
15	14	13	12	11	10	9	8
Reserved							
7	6	5	4	3	2	1	0
Reserved				BistFail		Finish	BISTEN



BITS	DESCRIPTIONS	
[31:4]	Reserved	-
[3:2]	BistFail	<p>BIST Fail</p> <p>The BistFail indicates if the BIST test failed or succeeded. If the BistFail is low at the end the embedded SRAM passed the BIST test, otherwise, it failed. The BistFail is high once the BIST detects the error and remains high during BIST operation.</p> <p>The BistFail is a “write clear field”. Writing 1 to this field clears the content and writing 0 has no effect.</p>
[1]	Finish	<p>BIST Operation Finish</p> <p>It indicates the end of the BIST operation. When BIST controller finishes all operations, this bit is set high.</p> <p>This bit is a “write clear” field. Writing 1 to this field clears the content and writing 0 has no effect.</p>
[0]	BISTEN	<p>BIST Enable</p> <p>BISTEN is used to enable the BIST operation. If set to high, the BIST controller performs embedded SRAM test. This bit is also used to reset the BIST circuit. It is necessary to reset the BIST circuit one clock cycle at least in order to initialize the BIST properly.</p> <p>BISTEN can be disabled by writing 0.</p>

SD Interface Control Register (SDICR)

REGISTER	ADDRESS	R/W	DESCRIPTION	RESET VALUE
SDICR	0xFFF0_7300	R/W	SD Interface Control Register	0x0000_0000

31	30	29	28	27	26	25	24
Reserved							
23	22	21	20	19	18	17	16
Reserved							
15	14	13	12	11	10	9	8
SD_CS	Reserved	CMD_CODE					
7	6	5	4	3	2	1	0
CLK_KEEP	8CLK_OE	74CLK_OE	R2_EN	DO_EN	DI_EN	RI_EN	CO_EN

W90P710CD/W90P710CDG



BITS	DESCRIPTIONS	
[31:16]	Reserved	-
[15]	SD_CS	SD Card Select Control 0=Select SD card-0 1=Select SD card-1 It is fixed to 0 at W90P710
[13:8]	CMD_CODE	SD Command Code This register contains the SD command code (00H – 3FH).
[7]	CLK_KEEP	SD Clock Enable 0=Disable SD clock generation 1=SD clock always keeps free running.
[6]	8CLK_OE	8 Clock Cycles Output Enable 0=Disable 1=Enable, SD host controller output 8 clock cycles When the operation is finished, this bit is automatically cleared to 0 via H/W circuit.
[5]	74CLK_OE	74 Clock Cycle Output Enable 0=Disable 1=Enable, SD host controller outputs 74 clock cycles When the operation is finished, this bit is automatically cleared to 0 via H/W circuit.
[4]	R2_EN	Response R2 Input Enable 0=Disable 1=Enable, SD host controller will wait to receive a response R2 from DS card and store the response data into flash buffer. When the R2 response operation is finished, this bit is automatically cleared to 0 via H/W circuit.
[3]	DO_EN	Data Output Enable 0=Disable 1=Enable, SD host controller will transfer a single data block and the CRC-16 code to the SD card. When the data output operation is finished, this bit is automatically cleared to 0 via H/W circuit.
[2]	DI_EN	Data Input Enable 0=Disable 1=Enable, SD host controller will wait to receive a single data block and the CRC-16 code from SD card. When the data input operation is finished, this bit is automatically cleared to 0 by H/W circuit.



Continued

BITS	DESCRIPTIONS	
[1]	RI_EN	Response Input Enable 0=Disable 1=Enable, SD host controller will wait to receive a response from SD card. When the response operation is finished, this bit is automatically cleared to 0 via H/W circuit.
[0]	CO_EN	Command Output Enable 0=Disable 1=Enable, SD host controller will transfer a command to SD card. When the command operation is finished, this bit is automatically cleared to 0 via H/W circuit.

SD Host interface Initial Register (SDHIIR)

REGISTER	ADDRESS	R/W	DESCRIPTION	RESET VALUE
SDHIIR	0xFFF0_7304	R/W	SD Host Interface Initial Register	0x0000_0018

31	30	29	28	27	26	25	24
Reserved							
23	22	21	20	19	18	17	16
Reserved							
15	14	13	12	11	10	9	8
Reserved							SPD
7	6	5	4	3	2	1	0
SD_CLK							

BITS	DESCRIPTIONS	
[31:9]	Reserved	-
[8]	SPD	Data Bus Width Control 0=1-bit data bus 1=4-bit data bus
[7:0]	SD_CLK	SD Clock Control The frequency of SD clock is equal to (Input Clock/(SD_CLK+1)). The SD_CLK = 8'h00 is reserved.



SD Interface Interrupt Enable Register (SDIIER)

REGISTER	ADDRESS	R/W	DESCRIPTION	RESET VALUE
SDIIER	0xFFF0_7308	R/W	SD Interface Interrupt Enable Register	0x0000_0000

31	30	29	28	27	26	25	24
Reserved							
23	22	21	20	19	18	17	16
Reserved							
15	14	13	12	11	10	9	8
Reserved							
7	6	5	4	3	2	1	0
Reserved			SD_IEN	DAT0_IEN	CD_IEN	DO_IEN	DI_IEN

BITS	DESCRIPTIONS	
[31:5]	Reserved	-
[4]	SD_IEN	SD Interrupt Status Enable 0=Disable SD_IS interrupt generation 1=Enable SD_IS interrupt generation
[3]	DAT0_IEN	SD DAT0 Level Transition Interrupt Status Enable 0=Disable DAT0_STS interrupt generation 1=Enable DAT0_STS interrupt generation
[2]	CD_IEN	CD# Interrupt Status Enable 0=Disable CD_IS interrupt generation 1=Enable CD_IS interrupt generation
[1]	DO_IEN	Data Output Interrupt Status Enable 0=Disable DO_IS interrupt generation 1=Enable DO_IS interrupt generation
[0]	DI_IEN	Data Input Interrupt Status Enable 0=Disable DI_IS interrupt generation 1=Enable DI_IS interrupt generation



SD Interface Interrupt Status Register (SDIISR)

REGISTER	ADDRESS	R/W	DESCRIPTION	RESET VALUE
SDISR	0xFFF0_730C	R/W	SD Interface Interrupt Status Register	0x0000_00XX

31	30	29	28	27	26	25	24
Reserved							
23	22	21	20	19	18	17	16
Reserved							
15	14	13	12	11	10	9	8
Reserved					DAT1_IS_	SD_DATA0	DAT0_STS
7	6	5	4	3	2	1	0
CD_	R2_CRC7	CRC	CRC-16	CRC-7	CD_IS	DO_IS	DI_IS

BITS	DESCRIPTIONS	
[31:11]	Reserved	-
[10]	DAT1_IS_	<p>SD Interrupt Value Status 0 = SD interrupt at interrupt period. Write 1 to clear this status bit (set DAT1_IS_ to 1). 1 = no SD interrupt at interrupt period. If SD_IEN is set and DAT1_IS_ is 0, an interrupt request is generated. Interrupt period is defined:</p> <p>(1) If SD data bus width is 1 and DAT[1] is unused, the interrupt period is any time on DAT[1] (2) If SD data bus width is 4, the interrupt period is at the single clock that is 2 clocks after the End bit of data block</p>
[9]	SD_DATA0	SD DAT0 Value
[8]	DAT0_STS	<p>SD Level Transition Status 0=No level transition 1=DAT0 value changes from high to low or low to high. Write 1 to clear this status bit.</p>
[7]	CD_	Card Detection Indicator
[6]	R2_CRC7	<p>Response R2 CRC-7 Check Status 0=Fault 1=OK</p>
[5]	CRC	<p>CRC Check Result Status 0=Fault 1=OK</p>

W90P710CD/W90P710CDG



Continued.

BITS		DESCRIPTIONS
[4]	CRC-16	CRC-16 Check Result Status 0=Fault 1=OK
[3]	CRC-7	CRC-7 Check Result Status 0=Fault 1=OK
[2]	CD_IS	CD# Interrupt Status 0=No Interrupt Generated 1=Interrupt Generated Note: Writing 1 to this bit will clear the interrupt status.
[1]	DO_IS	Data Output Interrupt Status 0=No Interrupt Generated 1=Interrupt Generated Note: Writing 1 to this bit will clear the interrupt status.
[0]	DI_IS	Data Input Interrupt Status 0=No Interrupt Generated 1=Interrupt Generated Note: Writing 1 to this bit will clear the interrupt status.

SD Command Argument Register (SDAUG)

REGISTER	ADDRESS	R/W	DESCRIPTION	RESET VALUE
SDAUG	0xFFFF0_7310	R/W	SD Command Argument Register	0x0000_0000

31	30	29	28	27	26	25	24
SD_CMD_ARG							
23	22	21	20	19	18	17	16
SD_CMD_ARG							
15	14	13	12	11	10	9	8
SD_CMD_ARG							
7	6	5	4	3	2	1	0
SD_CMD_ARG							



BITS	DESCRIPTIONS	
[31:0]	SD_CMD_ARG	SD Command Argument This register contains a 32-bit value specifying the argument of the SD command from host controller.

SD Receive Response Token Register 0 (SDRSP0)

REGISTER	ADDRESS	R/W	DESCRIPTION	RESET VALUE
SDRSP0	0xFFF0_7314	R	SD Receive Response Token Register 0	0XXXXX_XXXX

31	30	29	28	27	26	25	24
SD_RSP_TK0							
23	22	21	20	19	18	17	16
SD_RSP_TK0							
15	14	13	12	11	10	9	8
SD_RSP_TK0							
7	6	5	4	3	2	1	0
SD_RSP_TK0							

BITS	DESCRIPTIONS	
[31:0]	SD_RDP_TK0	SD Receive Response Token 0 SD host controller will receive a response token for getting a reply from the SD card. This register records the bit 47-16 of the response token.

SD Receive Response Token Register 1 (SDRSP1)

REGISTER	ADDRESS	R/W	DESCRIPTION	RESET VALUE
SDRSP1	0xFFF0_7318	R	SD Receive Response Token Register 1	0x0000_XXXX

31	30	29	28	27	26	25	24
Reserved							
23	22	21	20	19	18	17	16
Reserved							
15	14	13	12	11	10	9	8
Reserved							
7	6	5	4	3	2	1	0
SD_RSP_TK1							

W90P710CD/W90P710CDG



BITS	DESCRIPTIONS	
[31:8]	Reserved	-
[7:0]	SD_RSP_TK1	SD Receive Response Token 1 SD host controller will receive a response token for getting a reply from the SD card. This register records the bit 15-8 of the response token.

SD Block Length Register (SDBLEN)

REGISTER	ADDRESS	R/W	DESCRIPTION	RESET VALUE
SDBLEN	0xFFFF0_731C	R/W	SD Block Length Register	0x0000_0000

31	30	29	28	27	26	25	24
Reserved							
23	22	21	20	19	18	17	16
Reserved							
15	14	13	12	11	10	9	8
Reserved							SDBLEN
7	6	5	4	3	2	1	0
SDBLEN							

BITS	DESCRIPTIONS	
[31:9]	Reserved	-
[8:0]	SDBLEN	SD BLOCK LENGTH A 9-bit value specifies the SD transfer byte count.

Flash Buffer 0 Registers (FB0_0 ~ FB0_127)

REGISTER	ADDRESS	R/W	DESCRIPTION	RESET VALUE
FB0_0 FB0_127	0xFFFF0_7400 0xFFFF0_75FC	R/W	Flash Buffer 0	Undefined

W90P710CD/W90P710CDG



31	30	29	28	27	26	25	24
FBuf0							
23	22	21	20	19	18	17	16
FBuf0							
15	14	13	12	11	10	9	8
FBuf0							
7	6	5	4	3	2	1	0
FBuf0							

BITS		DESCRIPTIONS
[31:0]	FBuf0	Flash Buffer 0 These register ports supports the data read from embedded flash buffer 0. The embedded flash buffer size is 512 bytes, the 128 words. Consequently, the address range for flash buffer 0 is from 0xFFFF0_7400 to 0xFFFF0_75FC.

Flash Buffer 1 Registers (FB1_0 ~ FB1_127)

REGISTER	ADDRESS	R/W	DESCRIPTION	RESET VALUE
FB1_0 FB1_127	0xFFFF0_7800 0xFFFF0_79FC	R/W	Flash Buffer 1	Undefined

31	30	29	28	27	26	25	24
FBuf1							
23	22	21	20	19	18	17	16
FBuf1							
15	14	13	12	11	10	9	8
FBuf1							
7	6	5	4	3	2	1	0
FBuf1							

BITS		DESCRIPTIONS
[31:0]	FBuf1	Flash Buffer 1 These register ports supports the data read from embedded flash buffer 1. The embedded flash buffer size is 512 bytes, the 128 words. Consequently, the address range for flash buffer 1 is from 0xFFFF0_7800 to 0xFFFF0_79FC.

W90P710CD/W90P710CDG



6.10 LCD Controller

6.10.1 Main Features

STN LCD Display

- Supports 4-bit single scan Monochrome STN LCD panel, 8-bit single scan Monochrome STN LCD panel, 8-bit single scan Color STN LCD panel (all Sync-type)
- Up to 16 gray level display for Monochrome STN LCD panel
- Up to 4096 (12bpp) color display for Color STN LCD panel
- Virtual coloring method: Frame Rate Control (16 levels)
- Anti-flickering method: Time-based Dithering

TFT LCD Display

- Supports Sync-type TFT LCD panel and Sync-type High-color TFT LCD panel
- Supports direct or palletized color display

TV Encoder

- Supports 8-bit CCIR 601 YCbCr data output format to connect with external TV Encoder

LCD Preprocessing

- Supports RGB Raw-data or YUV422 packet format
- Programmable parameters for different image size
- Two Built-in FIFOs, FIFO 1 is for Video image and FIFO 2 is for OSD image. Each FIFO is 16 words deep

LCD Post processing

- Support for one OSD (On Screen Display) overlay
- Support various OSD function
- Programmable parameters for different display panels

Others

- Color lookup table size 256x32 bit for TFT used when displaying 1bpp, 2bpp, 4bpp, 8bpp image
- Dedicated DMA for block transfer mode

W90P710CD/W90P710CDG



6.10.2 LCD Register MAP

REGISTER	ADDRESS	R/W	DESCRIPTION	RESET VALUE
LCD Controller				
LCDCON	0xFFFF0_8000	R/W	LCD Control	0x0000_0000
LCD Interrupt Control				
LCDINTENB	0xFFFF0_8004	R/W	LCD Interrupt Enable	0x0000_0000
LCDINTS	0xFFFF0_8008	R	LCD Interrupt Status	0x0000_0000
LCDINTC	0xFFFF0_800C	W	LCD Interrupt Clear	0x0000_0000
LCD Pre-processing				
OSDUPSCF	0xFFFF0_8010	R/W	OSD Horizontal/Vertical upscaling factor	0x0000_0000
VDUPSCF	0xFFFF0_8014	R/W	Video Horizontal/Vertical upscaling factor	0x0000_0000
OSDDNSCF	0xFFFF0_8018	R/W	OSD Horizontal/Vertical Downscaling factor	0x0000_0000
VDDNSCF	0xFFFF0_801C	R/W	Video Horizontal/Vertical Downscaling factor	0x0000_0000
LCD FIFO Control				
FIFOCON	0xFFFF0_8020	R/W	FIFOs control	0x0000_0000
FIFOSTATUS	0xFFFF0_8024	R	FIFOs status	0x0000_0000
FIFO1PRM	0xFFFF0_8028	R/W	FIFO1 parameters	0x0000_0000
FIFO2PRM	0xFFFF0_802C	R/W	FIFO2 parameters	0x0000_0000
FIFO1SADDR	0xFFFF0_8030	R/W	FIFO1 start address	0x0000_0000
FIFO2SADDR	0xFFFF0_8034	R/W	FIFO2 start address	0x0000_0000
FIFO1DREQCNT	0xFFFF0_8038	R/W	FIFO1 data request count	0x0000_0000
FIFO2DREQCNT	0xFFFF0_803C	R/W	FIFO2 data request count	0x0000_0000
FIFO1CURADR	0xFFFF0_8040	R	FIFO1 current access address	0x0000_0000
FIFO2CURADR	0xFFFF0_8044	R	FIFO2 current access address	0x0000_0000
FIFO1RELACOLCNT	0xFFFF0_8048	R/W	FIFO1 real column count	0x0000_0000
FIFO2RELACOLCNT	0xFFFF0_804C	R/W	FIFO2 real column count	0x0000_0000
Color Generation				
VDLUTENTRY1	0xFFFF0_8050	R/W	Video lookup table entry index 1	0x0000_0000
VDLUTENTRY2	0xFFFF0_8054	R/W	Video lookup table entry index 2	0x0000_0000
VDLUTENTRY3	0xFFFF0_8058	R/W	Video lookup table entry index 3	0x0000_0000
VDLUTENTRY4	0xFFFF0_805C	R/W	Video lookup table entry index 4	0x0000_0000

W90P710CD/W90P710CDG



LCD Register MAP, continued

REGISTER	ADDRESS	R/W	DESCRIPTION	RESET VALUE
OSDLUTENTRY1	0xFFFF0_8060	R/W	OSD lookup table entry index 1	0x0000_0000
OSDLUTENTRY2	0xFFFF0_8064	R/W	OSD lookup table entry index 2	0x0000_0000
OSDLUTENTRY3	0xFFFF0_8068	R/W	OSD lookup table entry index 3	0x0000_0000
OSDLUTENTRY4	0xFFFF0_806C	R/W	OSD lookup table entry index 4	0x0000_0000
DITHP1	0xFFFF0_8070	R/W	Gray level dithered data duty pattern 1	0x0101_0001
DITHP2	0xFFFF0_8074	R/W	Gray level dithered data duty pattern 2	0x1111_0841
DITHP3	0xFFFF0_8078	R/W	Gray level dithered data duty pattern 3	0x4949_2491
DITHP4	0xFFFF0_807C	R/W	Gray level dithered data duty pattern 4	0x5555_52A5
DITHP5	0xFFFF0_8080	R/W	Gray level dithered data duty pattern 5	0xB6B6_B556
DITHP6	0xFFFF0_8084	R/W	Gray level dithered data duty pattern 6	0xEEEE_DB6E
DITHP7	0xFFFF0_8088	R/W	Gray level dithered data duty pattern 7	0xEFEF_EFBE
LCD Post-processing				
DDISPCP	0xFFFF0_8090	R/W	Dummy Display Color Pattern	0x0000_0000
VWINS	0xFFFF0_8094	R/W	Video Window Starting Coordinate	0x0000_0000
VWINE	0xFFFF0_8098	R/W	Video Window Ending Coordinate	0x0000_0000
OSDWINS	0xFFFF0_809C	R/W	OSD Window Starting Coordinate	0x0000_0000
OSDWINE	0xFFFF0_80A0	R/W	OSD Window Ending Coordinate	0x0000_0000
OSDOVCN	0xFFFF0_80A4	R/W	OSD Overlay Control	0x0000_0000
OSDCKP	0xFFFF0_80A8	R/W	OSD Overlay Color-Key Pattern	0x0000_0000
OSDCKM	0xFFFF0_80AC	R/W	OSD Overlay Color-Key Mask	0x0000_0000
LCD Timing Generation				
LCDTCON1	0xFFFF0_80B0	R/W	LCD Timing Control 1	0x0000_0000
LCDTCON2	0xFFFF0_80B4	R/W	LCD Timing Control 2	0x0000_0000
LCDTCON3	0xFFFF0_80B8	R/W	LCD Timing Control 3	0x0000_0000
LCDTCON4	0xFFFF0_80BC	R/W	LCD Timing Control 4	0x0000_0000
LCDTCON5	0xFFFF0_80C0	R/W	LCD Timing Control 5	0x0000_0000
LCDTCON6	0xFFFF0_80C4	R	LCD Timing Control 6	0x0000_0000
Lookup Table SRAM Build In Self Test				
BIST	0xFFFF0_80D0	R/W		0x0000_0000
Lookup Table SRAM				
	0xFFFF0_0100 ... 0xFFFF0_84FF	R/W	Look-Up Table RAM	0xXXXX_XXXX

W90P710CD/W90P710CDG



6.10.3 LCD Special Register Description

6.10.3.1 LCD Controller

LCD Control Register (LCDCON)

REGISTER	ADDRESS	R/W	DESCRIPTION	RESET VALUE
LCDCON	0xFFF0_8000	R/W	LCD control	0x0000_0000

31	30	29	28	27	26	25	24
Reserved		PPRST	LCDRST	Reserved	LUTWREN	OSDEN	LCDCEN
23	22	21	20	19	18	17	16
LCDMON8	LCDBW	YUV_nRGB	TVEN	PIXELSEQ		TFTTYPE	LCDTFT
15	14	13	12	11	10	9	8
Reserved		YUVSEQ		RGBSEQ		LCDBUS	
7	6	5	4	3	2	1	0
OSDLUTEN	OSDBPP			VDLUTEN	VDBPP		

BITS	DESCRIPTIONS	
[31:30]	Reserved	Reserved
[29]	PPRST	LCD Pre-Processor Reset 0 = Disable, normal operation 1 = Only reset the LCD Pre-Processor, clear FIFO, AHB protocol restart.
[28]	LCDRST	LCD Controller Reset (except Control Registers) 0 = Disable, normal operation 1 = Reset the whole LCD Controller include LCD Timing Generator
[27]	Reserved	Reserved
[26]	LUTWREN	Lookup Table SRAM Write/Read Enable 0 = Disable 1 = Enable
[25]	OSDEN	OSD Function Control 0 = Disable 1 = Enable
[24]	LCDCEN	LCD Controller Enable 0 = Disable VSYNC, HSYNC, VCLK, VD, and VDEN 1 = Enable VSYNC, HSYNC, VCLK, VD, and VDEN

W90P710CD/W90P710CDG



Continued

BITS		DESCRIPTIONS
[23]	LCDMON8	Monochrome LCD has an 8-bit interface 0 = mono LCD use 4-bit interface 1 = mono LCD use 8-bit interface
[22]	LCDBW	STN LCD is monochrome 0 = STN LCD is color 1 = STN LCD is monochrome
[21]	YUV_nRGB	Image stored in memory device is YUV format or RGB format 0 = RGB format 1 = YUV format If this bit is set to 1, VDBPP and OSDBPP must be set to 101 (16bpp)
[20]	TVEN	External TV encoder Enable 0 = Normal operation 1 = Convert RGB to YCbCr for external TV encoder
[19:18]	PIXELSEQ	Display pixel sequence for sync-type TFT 00 = R1 G1 B2 R2 G3 R3 01 = R1 G2 B3 R4 G5 B6 10 = R1 G1 B1 R2 G2 B2 11 = Reserved
[17]	TFTTYPE	TFT Type Select 0 = Sync-type High Color TFT LCD 1 = Sync-type TFT LCD
[16]	LCDTFT	LCD is TFT 0 = LCD is an STN display 1 = LCD is a TFT display
[15:14]	Reserved	Reserved
[13:12]	YUV_SEQ	YUV output sequence(only used for the TV-Encoder) 00 = UYVY 01 = YUYV 10 = VYUY 11 = YVYU
[11:10]	RGBSEQ	LCD Line Data Sequence(only used for Sync-Type non High Color TFT) 00 = First line data is RGB, second line data is GBR 01 = First line data is BGR, second line data is RBG 10 = First line data is GBR, second line data is RGB 11 = First line data is RBG, second line data is BGR

W90P710CD/W90P710CDG



Continued

BITS		DESCRIPTIONS
[9:8]	LCDBUS	LCD Data output remap (Only used at Sync-type High Color TFT) 00 = Databus is 24bit 01 = Databus is 18bit 10 = Databus is 8bit 11 = Reserved
[7]	OSDLUTEN	OSD Lookup Table Enable 0 = display OSD color directly from image 1 = display OSD color from lookup table
[6:4]	OSDBPP	OSD image bits per pixel 000 = 1 bpp 2 gray levels 001 = 2 bpp 4 gray levels 010 = 4 bpp 16 gray levels 011 = 8 bpp RGB332 100 = 12 bpp RGB444 101 = 16 bpp RGB565 110 = 18 bpp RGB666 111 = 24 bpp RGB888
[3]	VDLUTEN	Video Lookup Table Enable 0 = display Video color directly from image 1 = display Video color from lookup table
[2:0]	VDBPP	Video image bits per pixel 000 = 1 bpp 2 gray-levels 001 = 2 bpp 4 gray-levels 010 = 4 bpp 16 gray-levels 011 = 8 bpp RGB332 100 = 12 bpp RGB444 101 = 16 bpp RGB565 110 = 18 bpp RGB666 111 = 24 bpp RGB888

Output format of LCD Panel

Sync-type High Color TFT:

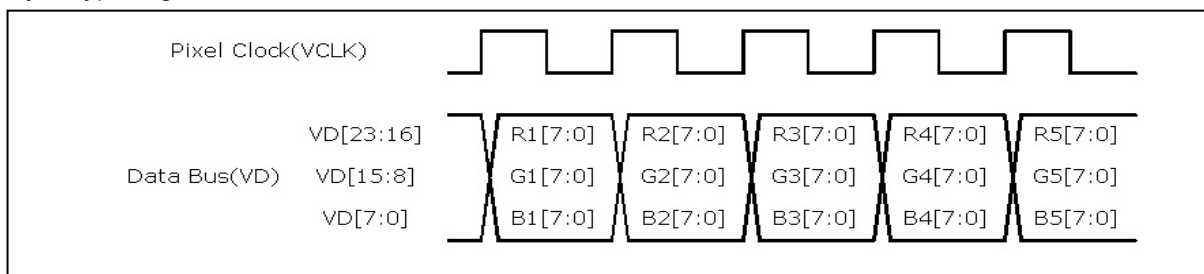

Fig. 6.10.3.1 Sync-type High Color TFT output format

W90P710CD/W90P710CDG



Sync-type TFT:

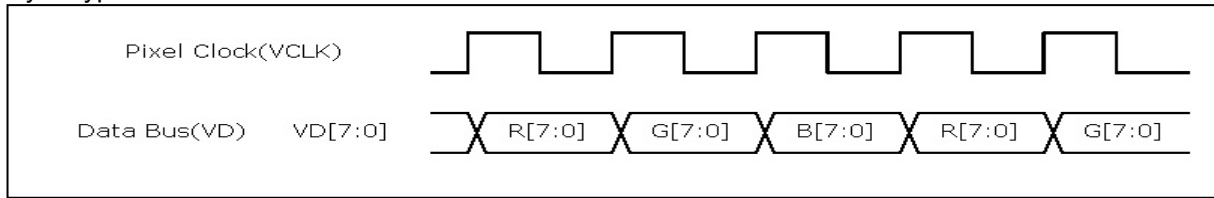

Fig. 6.10.3.2 Sync-type TFT output format

TV-Encoder:

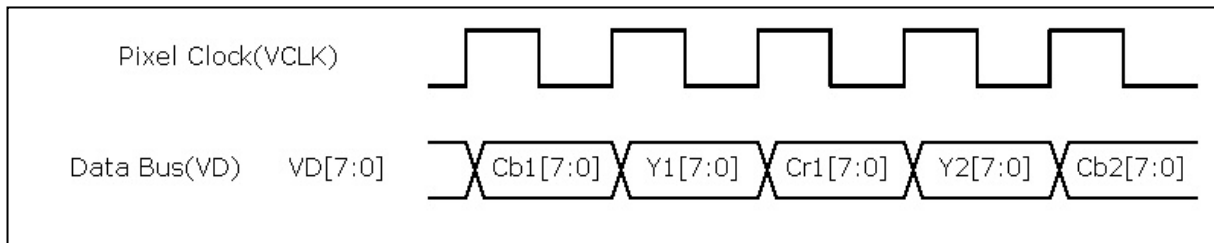

Fig. 6.10.3.3 TV-Encoder output format

Color STN:

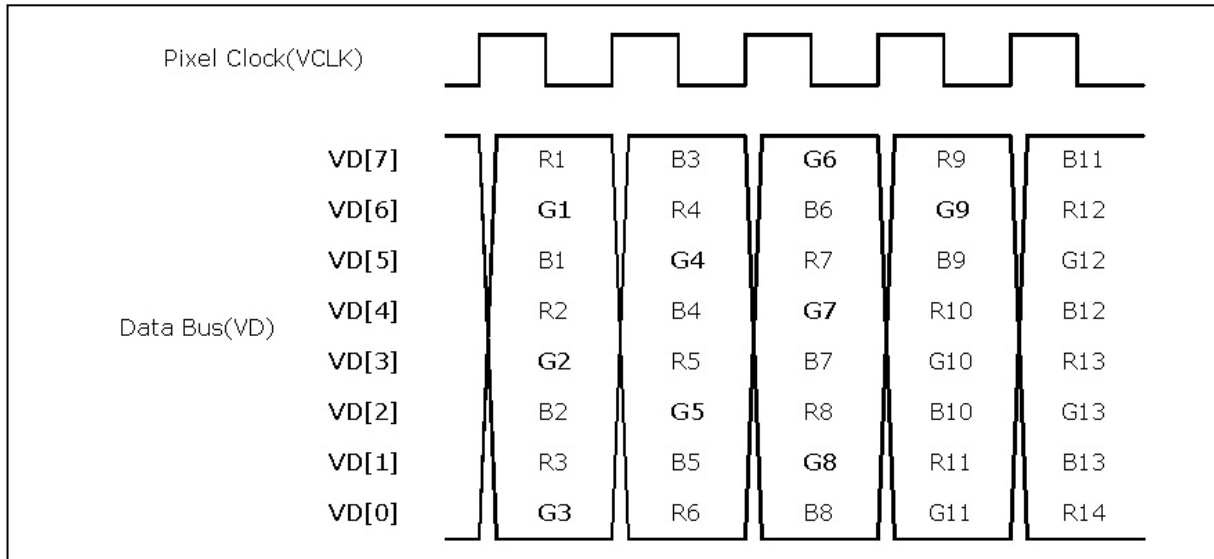

Fig. 6.10.3.4 Color STN output format

W90P710CD/W90P710CDG



Monochrome STN with 4-bit data bus:

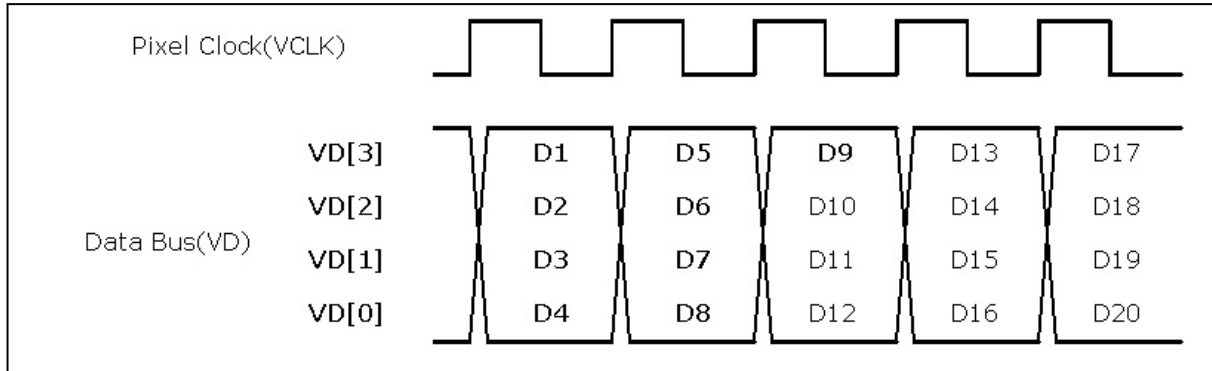

Fig. 6.10.3.5 Monochrome STN output format - 1

Monochrome STN with 8-bit data bus:

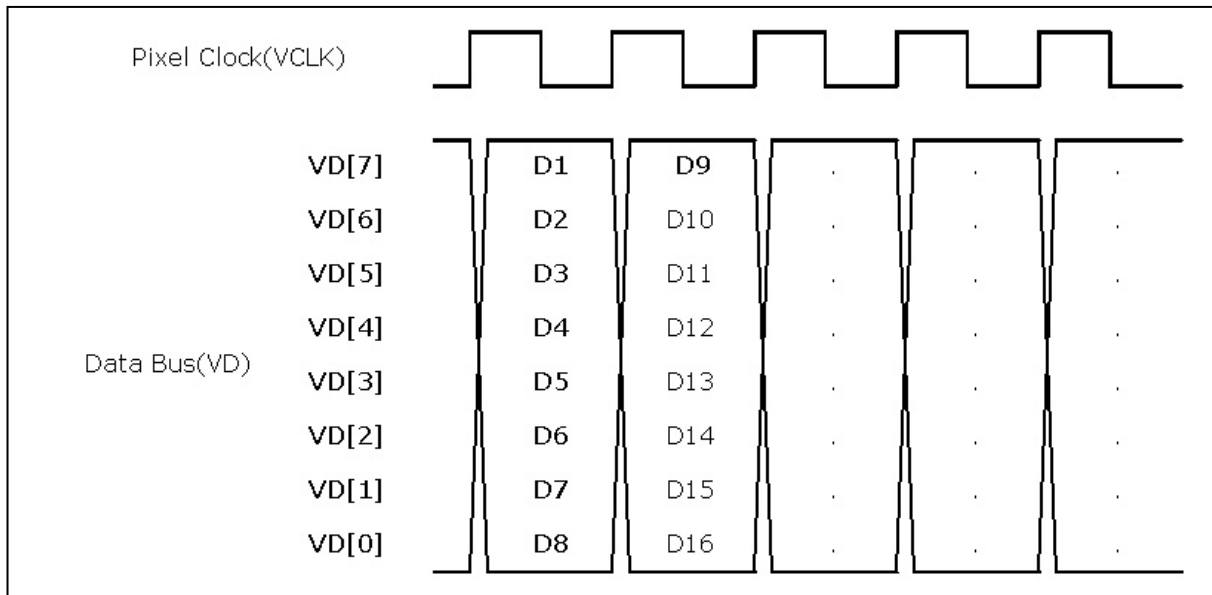

Fig. 6.10.3.6 Monochrome STN output format - 2

Only when LUTWREN is enabled, Lookup Table SRAM can be read or written by the CPU. If LUTWREN is disabled, the SRAM Lookup Table is accessed by the LCD Controller.

Palette function can't be enabled for STN panel. Because the SRAM Lookup Table is only 256 x32 bits, so if either the Video or OSD image is 8bpp, both VDLUTEN and OSDLUTEN can only be enabled when the Video Palette Table is the same as the OSD.

If VDLUTEN or OSDLUTEN is enabled, the LCD Controller will output data from the SRAM Lookup Table for 8bpp, 4bpp, 2bpp, 1bpp image. Otherwise the LCD Controller treats 8bpp data as RGB332, 4bpp as 16 gray levels, 2bpp as 4 gray levels, 1bpp as 2 gray levels (black and white).

Normally, the LCD Databus output is RGB888, 24-bit. If the LCDBUS is set to 01, the LCD Databus output is RGB666, 18-bit. If the LCDBUS is set to 10, the LCD Databus output is RGB332, 8-bit. The

W90P710CD/W90P710CDG



other bit is replaced with zero. Please refer to GPIO chapter to setting this register. This is only used for Sync-type High Color TFT because its databus is large, more than 8 bits. The databus of the other panel is only 8-bit so you don't need to set this register.

VD	23	22	21	20	19	18	17	16	15	14	13	12	11	10	9	8	7	6	5	4	3	2	1	0
LCDBUS = 00	R[7:0]							G[7:0]							B[7:0]									
LCDBUS = 01	0							R[7:2]					G[7:2]					B[7:2]						
LCDBUS = 10	0															R[7:5]			G[7:5]			B[7:6]		

6.10.3.2 LCD Interrupt Control

The enable register, clear register, and status register for every interrupt type. Enable Mask set/clear register will branch firmware into the interrupt sub-routine. Firmware can read the status register to identify which interrupt is generated now. The write clear register clears the interrupt status. The status register is set even if firmware disables the enable register. The main-routine can read the status register and write the clear register.

LCD Interrupt Enable Register (LCDINTENB)

REGISTER	ADDRESS	R/W	DESCRIPTION	RESET VALUE
LCDINTENB	0xFFFFF0_0004	R/W	LCD interrupt enable	0x0000_0000

31	30	29	28	27	26	25	24
Reserved							
23	22	21	20	19	18	17	16
Reserved					UNDREN2	UNDREN1	AHBEREN
15	14	13	12	11	10	9	8
Reserved							
7	6	5	4	3	2	1	0
Reserved		HSEN	VSEN	VLFINEN2	VFFINEN2	VLFINEN1	VFFINEN1



BITS	DESCRIPTIONS	
[31:19]	Reserved	Reserved
[18]	UNDREN2	FIFO2 UNDERRUN interrupt enable
[17]	UNDREN1	FIFO1 UNDERRUN interrupt enable
[16]	AHBEREN	AHB ERROR interrupt enable
[15:6]	Reserved	Reserved
[5]	HSEN	HSYNC interrupt enable
[4]	VSEN	VSYNC interrupt enable
[3]	VLFINEN2	FIFO2 VLINE FINISH interrupt enable
[2]	VFFINEN2	FIFO2 VFRAME FINISH interrupt enable
[1]	VLFINEN1	FIFO1 VLINE FINISH interrupt enable
[0]	VFFINEN1	FIFO1 VFRAME FINISH interrupt enable

LCD Interrupt Status Register (LCDINTS)

REGISTER	ADDRESS	R/W	DESCRIPTION	RESET VALUE
LCDINTS	0xFFFF0_8008	R	LCD interrupt status	0x0000_0000

31	30	29	28	27	26	25	24
Reserved							
23	22	21	20	19	18	17	16
Reserved					UNDRIS2	UNDRIS1	AHBERIS
15	14	13	12	11	10	9	8
Reserved							
7	6	5	4	3	2	1	0
Reserved		HSIS	VSIS	VLFINIS2	VFFINIS2	VLFINIS1	VFFINIS1

W90P710CD/W90P710CDG



BITS	DESCRIPTIONS	
[31:20]	Reserved	Reserved
[18]	UNDRIS2	FIFO2 have no data for output to Panel
[17]	UNDRIS1	FIFO1 have no data for output to Panel
[16]	AHBERIS	AHB master bus error status
[15:6]	Reserved	Reserved
[5]	HSIS	Timing Generator output a HSYNC pulse
[4]	VSIS	Timing Generator output a VSYNC pulse
[3]	VLFINIS2	FIFO2 transfer one line stream complete
[2]	VFFINIS2	FIFO2 transfer one frame stream complete
[1]	VLFINIS1	FIFO1 transfer one line stream complete
[0]	VFFINIS1	FIFO1 transfer one frame stream complete

LCD Controller is an AHB Master at AMBA and fetching video data from an AHB Slave such as SDRAM or FLASH memory. If the AHB Slave response ERROR for LCD Controller's data request, AHBERIS is set.

If the data rate of the output to the LCD Panel is too fast and the data rate of fetch data from AMBA is too slow, there is no data in the FIFO for the LCD Panel's request, UNDRISx is set. LCD Timing Generation register needs to be re-configured.

HSIS and VSIS provide information for firmware to know the status of the LCD Panel.

VLFINISx and VFFINISx provide information for firmware to know how much data FIFO has fetched.



LCD Interrupt Clear Register (LCDINTC)

REGISTER	ADDRESS	R/W	DESCRIPTION	RESET VALUE
LCDINTC	0xFFFF0_800C	W	LCD interrupt clear	0x0000_0000

31	30	29	28	27	26	25	24
Reserved							
23	22	21	20	19	18	17	16
Reserved					UNDRIC2	UNDRIC1	AHBERIC
15	14	13	12	11	10	9	8
Reserved							
7	6	5	4	3	2	1	0
Reserved		HSIC	VSIC	VLFINIC2	VFFINIC2	VLFINIC1	VFFINIC1

BITS	DESCRIPTIONS	
[31:20]	Reserved	Reserved
[18]	UNDRIC2	Clear FIFO2 UNDERRUN interrupt
[17]	UNDRIC1	Clear FIFO1 UNDERRUN interrupt
[16]	AHBERIC	Clear MBERROR interrupt
[15:6]	Reserved	Reserved
[5]	HSIC	Clear HSYNC interrupt
[4]	VSIC	Clear VSYNC interrupt
[3]	VLFINIC2	Clear FIFO2 VLINEFINSH interrupt
[2]	VFFINIC2	Clear FIFO2 VFRAMFINSH interrupt
[1]	VLFINIC1	Clear FIFO1 VLINEFINSH interrupt
[0]	VFFINIC1	Clear FIFO1 VFRAMFINSH interrupt

W90P710CD/W90P710CDG



6.10.3.3 LCD Pre-processing

OSD Upscaling Factor Register (OSDUPSCF)

REGISTER	ADDRESS	R/W	DESCRIPTION	RESET VALUE
OSDUPSCF	0xFFFF0_8010	R/W	OSD Horizontal/Vertical upscaling factor	0x0000_0000

31	30	29	28	27	26	25	24
Reserved							
23	22	21	20	19	18	17	16
Reserved							
15	14	13	12	11	10	9	8
Reserved							
7	6	5	4	3	2	1	0
Reserved			OSDHUP		OSDVUP		Reserved

BITS	DESCRIPTIONS	
[31:5]	Reserved	Reserved
[4:3]	OSDHUP	OSD Stream Horizontal Upscaling 00=1x 01=2x 10=4x
[2:1]	OSDVUP	OSD Stream Vertical Upscaling 00=1x 01=2x 10=4x
[0]	Reserved	Reserved

Video Upscaling Factor Register (VDUPSCF)

REGISTER	ADDRESS	R/W	DESCRIPTION	RESET VALUE
VDUPSCF	0xFFFF0_8014	R/W	Video Horizontal/Vertical upscaling	0x0000_0000

W90P710CD/W90P710CDG



31	30	29	28	27	26	25	24
Reserved							
23	22	21	20	19	18	17	16
Reserved							
15	14	13	12	11	10	9	8
Reserved							
7	6	5	4	3	2	1	0
Reserved			VDHUP		VDVUP		Reserved

BITS	DESCRIPTIONS	
[31:5]	Reserved	Reserved
[4:3]	VDHUP	Video Horizontal Upscaling control 00=1x 01=2x 10=4x
[2:1]	VDVUP	Video Vertical Upscaling control 00=1x 01=2x 10=4x
[0]	Reserved	Reserved

OSD Downscaling Factor Register (OSDDNSCF)

REGISTER	ADDRESS	R/W	DESCRIPTION	RESET VALUE
OSDDNSCF	0xFFFF0_8018	R/W	OSD Horizontal/Vertical Downscaling	0x0000_0000

31	30	29	28	27	26	25	24
OSDVDNN							
23	22	21	20	19	18	17	16
OSDVDNM							
15	14	13	12	11	10	9	8
OSDHDNN							
7	6	5	4	3	2	1	0
OSDHDNM							

W90P710CD/W90P710CDG



BITS	DESCRIPTIONS	
[31:24]	OSDVDNN	An 8-bit value specifies the numerator part (N) of the vertical downscaling factor.
[23:16]	OSDVDNM	An 8-bit value specifies the numerator part (M) of the vertical downscaling factor.
[15:8]	OSDHDNN	An 8-bit value specifies the numerator part (N) of the Horizontal downscaling factor.
[7:0]	OSDHDNM	An 8-bit value specifies the numerator part (M) of the Horizontal downscaling factor.

Video Downscaling Factor Register (VDDNSCF)

REGISTER	ADDRESS	R/W	DESCRIPTION	RESET VALUE
VDDNSCF	0xFFFF0_801C	R/W	Video Horizontal/ Vertical downscaling factor	0x0000_0000

31	30	29	28	27	26	25	24
VDVDNN							
23	22	21	20	19	18	17	16
VDVDNM							
15	14	13	12	11	10	9	8
VDHDNN							
7	6	5	4	3	2	1	0
VDHDNM							

BITS	DESCRIPTIONS	
[31:24]	VDVDNN	An 8-bit value specifies the numerator part (N) of the vertical downscaling factor.
[23:16]	VDVDNM	An 8-bit value specifies the numerator part (M) of the vertical downscaling factor.
[15:8]	VDHDNN	An 8-bit value specifies the numerator part (N) of the Horizontal downscaling factor.
[7:0]	VDHDNM	An 8-bit value specifies the numerator part (M) of the Horizontal downscaling factor.

Up Scaling or Downscaling, firmware can choose only one function of it. If both factor registers are configured, the behavior of the LCD Controller is undefined.

W90P710CD/W90P710CDG



6.10.3.4 LCD FIFOs Controller

FIFO Control Register (FIFOCON)

REGISTER	ADDRESS	R/W	DESCRIPTION	RESET VALUE
FIFOCON	0xFFF0_8020	R/W	FIFOs control	0x0000_0000

31	30	29	28	27	26	25	24
Reserved				OSDBPP24SW	OSDBPP18SW	OSDHSWP	OSDBSWP
23	22	21	20	19	18	17	16
Reserved				VDBPP24SW	VDBPP18SW	VDHSWP	VDBSWP
15	14	13	12	11	10	9	8
Reserved							
7	6	5	4	3	2	1	0
Reserved						FIFOEN	

BITS	DESCRIPTIONS	
[31:28]	Reserved	Reserved
[27]	OSDBPP24SW	OSD image 24bpp swap control bit 0=Swap Disable 1=Swap Enable
[26]	OSDBPP18SW	OSD image 18bpp swap control bit 0=Swap Disable 1=Swap Enable
[25]	OSDHSWP	OSD half-word swap control bit. 0 = Swap Disable 1 = Swap Enable
[24]	OSDBSWP	OSD byte-swap control bit. 0 = Swap Disable 1 = Swap Enable
[23:20]	Reserved	Reserved
[19]	VDBPP24SW	Video image 24bpp swap control bit 0=Swap Disable 1=Swap Enable

W90P710CD/W90P710CDG



Continued

BITS	DESCRIPTIONS	
[18]	VDBPP18SW	Video image 18bpp swap control bit 0=Swap Disable 1=Swap Enable
[17]	VDHSWP	Video half-word swap control bit. 0 = Swap Disable 1 = Swap Enable
[16]	VDBSWP	Video byte-swap control bit. 0 = Swap Disable 1 = Swap Enable
[15:2]	Reserved	Reserved
[1:0]	FIFOEN	FIFOs transfer data enable x1 = FIFO1 transfer enable x0=FIFO1 transfer disable 1x = FIFO2 transfer enable 0x=FIFO2 transfer disable

FIFO Status Register (FIFOSTATUS)

REGISTER	ADDRESS	R/W	DESCRIPTION	RESET VALUE
FIFOSTATUS	0xFFF0_8024	R	FIFOs status	0x0000_0000

31	30	29	28	27	26	25	24
Reserved							
23	22	21	20	19	18	17	16
Reserved							
15	14	13	12	11	10	9	8
Reserved							
7	6	5	4	3	2	1	0
Reserved						MASTERID	

BITS	DESCRIPTIONS	
[31:2]	Reserved	Reserved
[1:0]	MASTERID	Currently, the data bus master 01 = FIFO1 grant the bus 11 = FIFO2 grant the bus



FIFO1 Parameter Register (FIFO1PRM)

REGISTER	ADDRESS	R/W	DESCRIPTION	RESET VALUE
FIFO1PRM	0xFFFF0_8028	R/W	FIFO1 parameters	0x0000_0000

31	30	29	28	27	26	25	24
F1STRIDE[15:8]							
23	22	21	20	19	18	17	16
F1STRIDE[7:0]							
15	14	13	12	11	10	9	8
Reserved							
7	6	5	4	3	2	1	0
Reserved			F1LOCK	F1BURSTY		F1TRANSZ	

BITS	DESCRIPTIONS	
[31:16]	F1STRIDE	Video frame buffer stride 16-bit value specifies the word offset of memory address of vertically adjacent line for FIFO1 fetching.
[15:5]	Reserved	Reserved
[4]	F1LOCK	FIFO1 lock transfer enable 0 = Disable 1 = Enable
[3:2]	F1BURSTY	FIFO1 burst transfer type 00 =4 data burst mode 01 =8 data burst mode 10 =16 data burst mode
[1:0]	F1TRANSZ	FIFO1 data width per-transfer 00=one byte 01=half word 10=one word

FIFO2 Parameter Register (FIFO2PRM)

REGISTER	ADDRESS	R/W	DESCRIPTION	RESET VALUE
FIFO2PRM	0xFFFF0_802C	R/W	FIFO2 parameters	0x0000_0000

W90P710CD/W90P710CDG



31	30	29	28	27	26	25	24
F2STRIDE[15:8]							
23	22	21	20	19	18	17	16
F2STRIDE[7:0]							
15	14	13	12	11	10	9	8
Reserved							
7	6	5	4	3	2	1	0
Reserved			F2LOCK	F2BURSTY		F2TRANSZ	

BITS	DESCRIPTIONS	
[31:16]	F2STRIDE	Video frame buffer stride 16-bit value specifies the word offset of memory address for vertically adjacent lines for FIFO2 fetching.
[15:5]	Reserved	Reserved
[4]	F2LOCK	FIFO2 lock transfer enable 0 = Disable 1 = Enable
[3:2]	F2BURSTY	FIFO2 burst transfer type 00 =4 data burst mode 01 =8 data burst mode 10 =16 data burst mode
[1:0]	F2TRANSZ	FIFO2 data width per-transfer 00=one byte 01=half word 10=one word

FIFO1 Start Address Register (FIFO1SADDR)

REGISTER	ADDRESS	R/W	DESCRIPTION	RESET VALUE
FIFO1SADDR	0xFFFF0_8030	R/W	FIFO1 start address	0x0000_0000

31	30	29	28	27	26	25	24
FIFO1SADDR[31:24]							
23	22	21	20	19	18	17	16
FIFO1SADDR[23:16]							
15	14	13	12	11	10	9	8
FIFO1SADDR[15:8]							
7	6	5	4	3	2	1	0
FIFO1SADDR[7:0]							



BITS	DESCRIPTIONS	
[31:0]	FIFO1SADDR	These bits indicate the source address of the bank location for the LCD frame buffer in system memory.

FIFO2 Start Address Register (FIFO2SADDR)

REGISTER	ADDRESS	R/W	DESCRIPTION	RESET VALUE
FIFO2SADDR	0xFFFF0_8034	R/W	FIFO2 start address	0x0000_0000

31	30	29	28	27	26	25	24
FIFO2SADDR[31:24]							
23	22	21	20	19	18	17	16
FIFO2SADDR[23:16]							
15	14	13	12	11	10	9	8
FIFO2SADDR[15:8]							
7	6	5	4	3	2	1	0
FIFO2SADDR[7:0]							

BITS	DESCRIPTIONS	
[31:0]	FIFO2SADDR	These bits indicate the source address of the bank location for the LCD frame buffer in system memory.

FIFO1 Request Count Register (FIFO1DREQCNT)

REGISTER	ADDRESS	R/W	DESCRIPTION	RESET VALUE
FIFO1DREQCNT	0xFFFF0_8038	R/W	FIFO1 request count	0x0000_0000

31	30	29	28	27	26	25	24
FIFO1COLCNT[31:24]							
23	22	21	20	19	18	17	16
FIFO1COLCNT[23:16]							
15	14	13	12	11	10	9	8
FIFO1ROWCNT[15:8]							
7	6	5	4	3	2	1	0
FIFO1ROWCNT[7:0]							



BITS	DESCRIPTIONS	
[31:16]	FIFO1COLCNT	These bits indicate the FIFO1 request count per-line of video
[15:0]	FIFO1ROWCNT	These bits indicate the FIFO1 request count per-frame of video

FIFO2 Request Count Register (FIFO2DREQCNT)

REGISTER	ADDRESS	R/W	DESCRIPTION	RESET VALUE
FIFO2DREQCNT	0xFFFF0_803C	R/W	FIFO2 data request count	0x0000_0000

31	30	29	28	27	26	25	24
FIFO2COLCNT[31:24]							
23	22	21	20	19	18	17	16
FIFO2COLCNT[23:16]							
15	14	13	12	11	10	9	8
FIFO2ROWCNT[15:8]							
7	6	5	4	3	2	1	0
FIFO2ROWCNT[7:0]							

BITS	DESCRIPTIONS	
[31:16]	FIFO2COLCNT	These bits indicate the FIFO2 request count per-line of video
[15:0]	FIFO2ROWCNT	These bits indicate the FIFO2 request count per-frame of video

FIFO1 Current Access Address Register (FIFO1CURADR)

REGISTER	ADDRESS	R/W	DESCRIPTION	RESET VALUE
FIFO1CURADR	0xFFFF0_8040	R	FIFO1 current access address	0x0000_0000



31	30	29	28	27	26	25	24
FIFO1CURADR[31:24]							
23	22	21	20	19	18	17	16
FIFO1CURADR[23:16]							
15	14	13	12	11	10	9	8
FIFO1CURADR[15:8]							
7	6	5	4	3	2	1	0
FIFO1CURADR[7:0]							

BITS	DESCRIPTIONS	
[31:0]	FIFO1CURADR	Contains the approximate current FIFO1 access data address

FIFO2 Current Access Address Register (FIFO2CURADR)

REGISTER	ADDRESS	R/W	DESCRIPTION	RESET VALUE
FIFO2CURADR	0xFF0_8044	R	FIFO2 current access address	0x0000_0000

31	30	29	28	27	26	25	24
FIFO2CURADR[31:24]							
23	22	21	20	19	18	17	16
FIFO2CURADR[23:16]							
15	14	13	12	11	10	9	8
FIFO2CURADR[15:8]							
7	6	5	4	3	2	1	0
FIFO2CURADR[7:0]							

BITS	DESCRIPTIONS	
[31:0]	FIFO2CURADR	Contains the approximate current FIFO2 access data address



FIFO1 Real Column Count Register (F1REALCULCNT)

REGISTER	ADDRESS	R/W	DESCRIPTION	RESET VALUE
FIFO1REALCULCNT	0xFFF0_8048	R/W	FIFO1 real column count	0x0000_0000

31	30	29	28	27	26	25	24
Reserved							
23	22	21	20	19	18	17	16
Reserved							
15	14	13	12	11	10	9	8
F1REALCOLCNT[15:8]							
7	6	5	4	3	2	1	0
F1REALCOLCNT[7:0]							

BITS	DESCRIPTIONS	
[31:16]	Reserved	Reserved
[15:0]	F1REALCOLCNT	These bits indicate the FIFO1 real column count per-frame of video

FIFO2 Real Column Count (F2REALCULCNT)

REGISTER	ADDRESS	R/W	DESCRIPTION	RESET VALUE
FIFO2REALCULCNT	0xFFF0_804C	R/W	FIFO2 real column count	0x0000_0000

31	30	29	28	27	26	25	24
Reserved							
23	22	21	20	19	18	17	16
Reserved							
15	14	13	12	11	10	9	8
F2REALCOLCNT[15:8]							
7	6	5	4	3	2	1	0
F2REALCOLCNT[7:0]							

W90P710CD/W90P710CDG



BITS	DESCRIPTIONS	
[31:16]	Reserved	Reserved
[15:0]	F2REALCOLCNT	These bits indicate the FIFO2 real column count per-line of video

24bpp image format:

(BSPW=0, HSWP=0, BPP24SWP=0)

	D[31:24]	D[23:0]
0000H	Dummy Bit	Pixel 1
0004H	Dummy Bit	Pixel 2
0008H	Dummy Bit	Pixel 3
.....		

(BSPW=0, HSWP=0, BPP24SWP=1)

	D[31:8]	D[7:0]
0000H	Pixel 1	Dummy Bit
0004H	Pixel 2	Dummy Bit
0008H	Pixel 3	Dummy Bit
.....		

18bpp image format:

(BSPW=0, HSWP=0, BPP18SWP=0)

	D[31:18]	D[17:0]
0000H	Dummy Bit	Pixel 1
0004H	Dummy Bit	Pixel 2
0008H	Dummy Bit	Pixel 3
.....		

W90P710CD/W90P710CDG



(BSWP=0, HSWP=0, BPP18SWP=1)

	D[31:18]	D[17:0]
0000H	Pixel 1	Dummy Bit
0004H	Pixel 2	Dummy Bit
0008H	Pixel 3	Dummy Bit
.....		

16bpp image format:

(BSWP=0, HSWP=0)

	D[31:16]	D[15:0]
0000H	Pixel 2	Pixel 1
0004H	Pixel 4	Pixel 3
0008H	Pixel 6	Pixel 5
.....		

(BSWP=0, HSWP=1)

	D[31:16]	D[15:0]
0000H	Pixel 1	Pixel 2
0004H	Pixel 3	Pixel 4
0008H	Pixel 5	Pixel 6
.....		

W90P710CD/W90P710CDG



12bpp image format:

(BSWP=0, HSWP=0)

	D[31:28]	P[27:16]	P[15:12]	D[11:0]
0000H	Dummy Bit	Pixel 2	Dummy Bit	Pixel 1
0004H	Dummy Bit	Pixel 4	Dummy Bit	Pixel 3
0008H	Dummy Bit	Pixel 6	Dummy Bit	Pixel 5
.....				

(BSWP=0, HSWP=1)

	D[31:28]	P[27:16]	P[15:12]	D[11:0]
0000H	Dummy Bit	Pixel 1	Dummy Bit	Pixel 2
0004H	Dummy Bit	Pixel 3	Dummy Bit	Pixel 4
0008H	Dummy Bit	Pixel 5	Dummy Bit	Pixel 6
.....				

8bpp image format:

(BSWP=0, HSWP=0)

	D[31:24]	P[23:16]	P[15:8]	D[7:0]
0000H	Pixel 4	Pixel 3	Pixel 2	Pixel 1
0004H	Pixel 8	Pixel 7	Pixel 6	Pixel 5
0008H	Pixel 12	Pixel 11	Pixel 10	Pixel 9
.....				

(BSWP=1, HSWP=0)

	D[31:24]	P[23:16]	P[15:8]	D[7:0]
0000H	Pixel 1	Pixel 2	Pixel 3	Pixel 4
0004H	Pixel 5	Pixel 6	Pixel 7	Pixel 8
0008H	Pixel 9	Pixel 10	Pixel 11	Pixel 12
.....				

W90P710CD/W90P710CDG



4bpp image format:

(BSWP=0, HSWP=0)

	D[31:28]	P[27:24]	D[23:20]	D[19:16]	D[15:12]	D[11:8]	D[7:4]	D[3:0]
0000H	Pixel 7	Pixel 8	Pixel 5	Pixel 6	Pixel 3	Pixel 4	Pixel 1	Pixel 2
0004H	Pixel 15	Pixel 16	Pixel 13	Pixel 14	Pixel 11	Pixel 12	Pixel 9	Pixel 10
.....								

(BSWP=1, HSWP=0)

	D[31:28]	P[27:24]	D[23:20]	D[19:16]	D[15:12]	D[11:8]	D[7:4]	D[3:0]
0000H	Pixel 1	Pixel 2	Pixel 3	Pixel 4	Pixel 5	Pixel 6	Pixel 7	Pixel 8
0004H	Pixel 9	Pixel 10	Pixel 11	Pixel 12	Pixel 13	Pixel 14	Pixel 15	Pixel 16
....								

2bpp image format:

(BSWP=0, HSWP=0)

0000H	D[31:30]	P[29:28]	D[27:26]	D[25:24]	D[23:22]	D[21:20]	D[19:18]	D[17:16]
	Pixel 13	Pixel 14	Pixel 15	Pixel 16	Pixel 9	Pixel 10	Pixel 11	Pixel 12
	D[15:14]	P[13:12]	D[11:10]	D[9:8]	D[7:6]	D[5:4]	D[3:2]	D[1:0]
	Pixel 5	Pixel 6	Pixel 7	Pixel 8	Pixel 1	Pixel 2	Pixel 3	Pixel 4
0004H	D[31:30]	P[29:28]	D[27:26]	D[25:24]	D[23:22]	D[21:20]	D[19:18]	D[17:16]
	Pixel 29	Pixel 30	Pixel 31	Pixel 32	Pixel 25	Pixel 26	Pixel 27	Pixel 28
	D[15:14]	P[13:12]	D[11:10]	D[9:8]	D[7:6]	D[5:4]	D[3:2]	D[1:0]
	Pixel 21	Pixel 22	Pixel 23	Pixel 24	Pixel 17	Pixel 18	Pixel 19	Pixel 20
.....								

W90P710CD/W90P710CDG



(BSWP=1, HSWP=0)

0000H	D[31:30]	P[29:28]	D[27:26]	D[25:24]	D[23:22]	D[21:20]	D[19:18]	D[17:16]
	Pixel 1	Pixel 2	Pixel 3	Pixel 4	Pixel 5	Pixel 6	Pixel 7	Pixel 8
	D[15:14]	P[13:12]	D[11:10]	D[9:8]	D[7:6]	D[5:4]	D[3:2]	D[1:0]
	Pixel 9	Pixel 10	Pixel 11	Pixel 12	Pixel 13	Pixel 14	Pixel 15	Pixel 16
0004H	D[31:30]	P[29:28]	D[27:26]	D[25:24]	D[23:22]	D[21:20]	D[19:18]	D[17:16]
	Pixel 17	Pixel 18	Pixel 19	Pixel 20	Pixel 21	Pixel 22	Pixel 23	Pixel 24
	D[15:14]	P[13:12]	D[11:10]	D[9:8]	D[7:6]	D[5:4]	D[3:2]	D[1:0]
	Pixel 25	Pixel 26	Pixel 27	Pixel 28	Pixel 29	Pixel 30	Pixel 31	Pixel 32
....								

1bpp image format:

(BSWP=0, HSWP=0)

0000H	D[31]	P[30]	D[29]	D[28]	D[27]	D[26]	D[25]	D[24]
	Pixel 25	Pixel 26	Pixel 27	Pixel 28	Pixel 29	Pixel 30	Pixel 31	Pixel 32
	D[23]	P[22]	D[21]	D[20]	D[19]	D[18]	D[17]	D[16]
	Pixel 17	Pixel 18	Pixel 19	Pixel 20	Pixel 21	Pixel 22	Pixel 23	Pixel 24
	D[15]	P[14]	D[13]	D[12]	D[11]	D[10]	D[9]	D[8]
	Pixel 9	Pixel 10	Pixel 11	Pixel 12	Pixel 13	Pixel 14	Pixel 15	Pixel 16
	D[7]	P[6]	D[5]	D[4]	D[3]	D[2]	D[1]	D[0]
	Pixel 1	Pixel 2	Pixel 3	Pixel 4	Pixel 5	Pixel 6	Pixel 7	Pixel 8
....								

W90P710CD/W90P710CDG



(BSWP=0, HSWP=0)

0000H	D[31]	P[30]	D[29]	D[28]	D[27]	D[26]	D[25]	D[24]
	Pixel 1	Pixel 2	Pixel 3	Pixel 4	Pixel 5	Pixel 6	Pixel 7	Pixel 8
	D[23]	P[22]	D[21]	D[20]	D[19]	D[18]	D[17]	D[16]
	Pixel 9	Pixel 10	Pixel 11	Pixel 12	Pixel 13	Pixel 14	Pixel 15	Pixel 16
	D[15]	P[14]	D[13]	D[12]	D[11]	D[10]	D[9]	D[8]
	Pixel 17	Pixel 18	Pixel 19	Pixel 20	Pixel 21	Pixel 22	Pixel 23	Pixel 24
	D[7]	P[6]	D[5]	D[4]	D[3]	D[2]	D[1]	D[0]
	Pixel 25	Pixel 26	Pixel 27	Pixel 28	Pixel 29	Pixel 30	Pixel 31	Pixel 32
.....								

If there is an image with size 480*480, 24bpp, stored in a memory device with starting address 0x30000000; 24bpp means there are 4 bytes to a pixel (3 bytes containing color, and a dummy byte). So:

```

FIFO1SADDR      = 0x30000000
FIFO1COLCNT     = 0x01E0
FIFO1ROWCNT     = 0x01E0
FIFO1REALCOLCNT = 0x01E0
    
```

The unit of FIFOCOLCNT is word. So, if the image is 16bpp, FIFO1COLCNT and FIFO1REALCOLCNT are modified to 0x00F0 because under 16bpp mode, a word contains two data pixels. When FIFO receives the value which FIFOCOLCNT specified, the VLINEFINSH interrupt is generated and

- (1) Row counter will increment. When row counter receives the value, which FIFOROWCNT specified, VFRAMFINSH interrupt is generated. So, FIFOROWCNT is not concerned with BPP.
- (2) FIFOSTRIDE is load in and added to the current accessed address

Column counter counts the FIFO writing pulse. If a Horizontal Upscaling factor is 2X, FIFO will extract a pixel data to two pixel data internal. So if Horizontal Upscaling function is enabled, FIFOCOLCNT need to divided again or VLINEFINSH interrupt is generated after the FIFO has received two columns of data and FIFOROWCNT and VFRAMFINSH interrupt is influenced too.

The same with Horizontal Downscaling function, so it's recommend that Horizontal Downscaling Factor M is a multiple of 4. When VFRAMEFINSH interrupt generated, the FIFO will fetch image data and restart at FIFO1SADDR.

W90P710CD/W90P710CDG

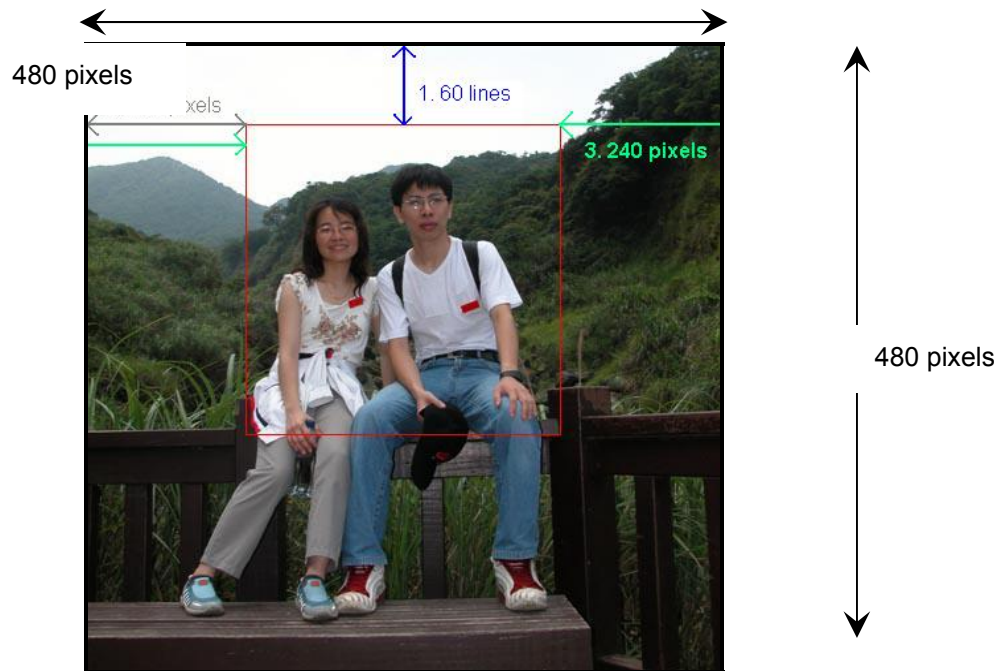

Fig. 6.10.5.7 FIFO parameter example

If there is an image with size 480*480, 24bpp, stored in the memory device with starting address 0x30000000, and connected with a 480*480 LCD Panel, and the user wants to show the whole image on the LCD Panel, the register settings are:

FIFO1SADDR = 0x30000000
FIFO1COLCNT = 0x01E0
FIFO1ROWCNT = 0x01E0
FIFO1REALCOLCNT = 0x01E0

If the LCD Controller is connected with a 240*240 LCD Panel or the user only wants to show a part (red line region, 240*240) of the whole image on a 480*480 LCD Panel, the register settings are:

FIFO1SADDR = 0x3001C3E0 (0x30000000 + 4*(480*60+120) = 0x3001C3E0)
FIFO1COLCNT = 0x00F0
FIFO1ROWCNT = 0x00F0
FIFOSTRIDE = 0x03C0 (240*4 = 0x03C0)
FIFO1REALCOLCNT = 0x00F0

After the register setting is complete, enable FIFO and it will fetch the image data according to the register value. In addition, if the image in FIFO is smaller than the LCD Panel, DISPWYS, DISPWXS, DISPWYE, DISPWXE must be configured.

Usually, FIFO Real Column Count is the same as FIFO Column Count. But if the Horizontal Downscaling function is enabled (factor M is not equal with N), FIFO Real Column Count specifies the column count of the original image, and FIFO Column Count specifies the column count of the scaled image.

W90P710CD/W90P710CDG



If there is a picture with N BPP and horizontal width X pixel, the word-count W of this picture is:

N BPP	W (WORD)
1 BPP (Black / White)	X % 32
2 BPP (4 gray levels)	X % 16
4 BPP (16 gray levels)	X % 8
8 BPP (RGB 332)	X % 4
12 BPP (RGB 444)	X % 2
16 BPP (RGB 565)	X % 2
18 BPP (RGB 666)	X % 1
24 BPP (RGB 888)	X % 1

The first limitation is that W must be an integer. The second limitation is that W must be a multiple of 8 for Colored STN panels. W can be a multiple of 4, 8 or 16 for other kinds of panels. If W is a multiple of 4, the register value of F1BURSTY (FIFO1PRM register) must be set to 00. If W is a multiple of 8, the register value of the F1BURSTY (FIFO1PRM register) must be set to 01. If W is a multiple of 16, the register value of F1BURSTY (FIFO1PRM register) must be set to 10.

If there is a picture with N BPP and horizontal width X pixel, which does not follow the limitations, define R as a quotient of W, and S as a quotient of R/16. Then the value of F1COLCNT (F1DREQCNT register) can be set to $D = (S + 1) * 16$, and DISPWXE can be set to X. Define $E = D * 4$. When software is writing the picture raw data into SDRAM and reaches the address of $X * 4$, software must jump to address E + 1 and then continue writing data.

6.10.3.5 Color Generation

Video Lookup Table Entry Index 1 Register (VDLUTENTRY1)

REGISTER	ADDRESS	R/W	DESCRIPTION	RESET VALUE
VDLUTENTRY1	0xFFFF0_8050	R/W	Video lookup table entry index 1	0x0000_0000

31	30	29	28	27	26	25	24
VDLUTENTRY1[31:24]							
23	22	21	20	19	18	17	16
VDLUTENTRY1[23:16]							
15	14	13	12	11	10	9	8
VDLUTENTRY1[15:8]							
7	6	5	4	3	2	1	0
VDLUTENTRY1[7:0]							



BITS	DESCRIPTIONS	
[31:0]	VDLUTENTY1	These bits define address of Lookup Table SRAM when Video pixel data is 00 = VDLUTENTY1[7:0] 01 = VDLUTENTY1[15:8] 10 = VDLUTENTY1[23:16] 11 = VDLUTENTY1[31:24]

Video Lookup Table Entry Index 2 Register (VDLUTENTY2)

REGISTER	ADDRESS	R/W	DESCRIPTION	RESET VALUE
VDLUTENTY2	0xFFF0_8054	R/W	Video lookup table entry index 2	0x0000_0000

31	30	29	28	27	26	25	24
VDLUTENTY2[31:24]							
23	22	21	20	19	18	17	16
VDLUTENTY2[23:16]							
15	14	13	12	11	10	9	8
VDLUTENTY2[15:8]							
7	6	5	4	3	2	1	0
VDLUTENTY2[7:0]							

BITS	DESCRIPTIONS	
[31:0]	VDLUTENTY2	These bits define the address of the SRAM Lookup Table when Video pixel data is 00 = VDLUTENTY2[7:0] 01 = VDLUTENTY2[15:8] 10 = VDLUTENTY2[23:16] 11 = VDLUTENTY2[31:24]



Video Lookup Table Entry Index 3 Register (VDLUTENTY3)

REGISTER	ADDRESS	R/W	DESCRIPTION	RESET VALUE
VDLUTENTY3	0xFFF0_8058	R/W	Video lookup table entry index 3	0x0000_0000

31	30	29	28	27	26	25	24
VDLUTENTY3[31:24]							
23	22	21	20	19	18	17	16
VDLUTENTY3[23:16]							
15	14	13	12	11	10	9	8
VDLUTENTY3[15:8]							
7	6	5	4	3	2	1	0
VDLUTENTY3[7:0]							

BITS	DESCRIPTIONS	
[31:0]	VDLUTENTY3	These bits define the address of the SRAM Lookup Table when Video pixel data is 00 = VDLUTENTY3[7:0] 01 = VDLUTENTY3[15:8] 10 = VDLUTENTY3[23:16] 11 = VDLUTENTY3[31:24]

Video Lookup Table Entry Index 4 Register (VDLUTENTY4)

REGISTER	ADDRESS	R/W	DESCRIPTION	RESET VALUE
VDLUTENTY4	0xFFF0_805C	R/W	Video lookup table entry index 4	0x0000_0000

31	30	29	28	27	26	25	24
VDLUTENTY4[31:24]							
23	22	21	20	19	18	17	16
VDLUTENTY4[23:16]							
15	14	13	12	11	10	9	8
VDLUTENTY4[15:8]							
7	6	5	4	3	2	1	0
VDLUTENTY4[7:0]							



BITS	DESCRIPTIONS	
[31:0]	VDLUTENTRY4	These bits define the address of the SRAM Lookup Table when Video pixel data is 00 = VDLUTENTRY4[7:0] 01 = VDLUTENTRY4[15:8] 10 = VDLUTENTRY4[23:16] 11 = VDLUTENTRY4[31:24]

OSD Lookup Table Entry Index 1 Register (OSDLUTENTRY1)

REGISTER	ADDRESS	R/W	DESCRIPTION	RESET VALUE
OSDLUTENTRY	0xFFF0_8060	R/W	OSD lookup table entry index 1	0x0000_0000

31	30	29	28	27	26	25	24
OSDLUTENTRY1[31:24]							
23	22	21	20	19	18	17	16
OSDLUTENTRY1[23:16]							
15	14	13	12	11	10	9	8
OSDLUTENTRY1[15:8]							
7	6	5	4	3	2	1	0
OSDLUTENTRY1[7:0]							

BITS	DESCRIPTIONS	
[31:0]	OSDLUTENTRY1	These bits define the address of the SRAM Lookup Table when OSD pixel data is 00 = OSDLUTENTRY1[7:0] 01 = OSDLUTENTRY1[15:8] 10 = OSDLUTENTRY1[23:16] 11 = OSDLUTENTRY1[31:24]



OSD Lookup Table Entry Index 2 Register (OSDLUTENTRY2)

REGISTER	ADDRESS	R/W	DESCRIPTION	RESET VALUE
OSDLUTENTRY2	0xFFFF0_8064	R/W	OSD lookup table entry index 2	0x0000_0000

31	30	29	28	27	26	25	24
OSDLUTENTRY2[31:24]							
23	22	21	20	19	18	17	16
OSDLUTENTRY2[23:16]							
15	14	13	12	11	10	9	8
OSDLUTENTRY2[15:8]							
7	6	5	4	3	2	1	0
OSDLUTENTRY2[7:0]							

BITS	DESCRIPTIONS	
[31:0]	OSDLUTENTRY2	These bits define the address of the SRAM Lookup Table when OSD pixel data is 00 = OSDLUTENTRY2[7:0] 01 = OSDLUTENTRY2[15:8] 10 = OSDLUTENTRY2[23:16] 11 = OSDLUTENTRY2[31:24]

OSD Lookup Table Entry Index 3 Register (OSDLUTENTRY3)

REGISTER	ADDRESS	R/W	DESCRIPTION	RESET VALUE
OSDLUTENTRY3	0xFFFF0_8068	R/W	OSD lookup table entry index 3	0x0000_0000

31	30	29	28	27	26	25	24
OSDLUTENTRY3[31:24]							
23	22	21	20	19	18	17	16
OSDLUTENTRY3[23:16]							
15	14	13	12	11	10	9	8
OSDLUTENTRY3[15:8]							
7	6	5	4	3	2	1	0
OSDLUTENTRY3[7:0]							



BITS	DESCRIPTIONS	
[31:0]	OSDLUTENTRY3	These bits define the address of the SRAM Lookup Table when OSD pixel data is 00 = OSDLUTENTRY3[7:0] 01 = OSDLUTENTRY3[15:8] 10 = OSDLUTENTRY3[23:16] 11 = OSDLUTENTRY3[31:24]

OSD Lookup Table Entry Index 4 Register (OSDLUTENTRY4)

REGISTER	ADDRESS	R/W	DESCRIPTION	RESET VALUE
OSDLUTENTRY4	0xFFFF0_806C	R/W	OSD lookup table entry index 4	0x0000_0000

31	30	29	28	27	26	25	24
OSDLUTENTRY4[31:24]							
23	22	21	20	19	18	17	16
OSDLUTENTRY4[23:16]							
15	14	13	12	11	10	9	8
OSDLUTENTRY4[15:8]							
7	6	5	4	3	2	1	0
OSDLUTENTRY4[7:0]							

BITS	DESCRIPTIONS	
[31:0]	OSDLUTENTRY4	These bits define the address of the SRAM Lookup Table when OSD pixel data is 00 = OSDLUTENTRY4[7:0] 01 = OSDLUTENTRY4[15:8] 10 = OSDLUTENTRY4[23:16] 11 = OSDLUTENTRY4[31:24]

Dithering Pattern 1 Register (DITHP1)

REGISTER	ADDRESS	R/W	DESCRIPTION	RESET VALUE
DITHP1	0xFFFF0_8070	R/W	Gray level dithered data duty pattern 1	0x0101_0001

W90P710CD/W90P710CDG



31	30	29	28	27	26	25	24
DP2[15:8]							
23	22	21	20	19	18	17	16
DP2[7:0]							
15	14	13	12	11	10	9	8
DP1[15:8]							
7	6	5	4	3	2	1	0
DP1[7:0]							

BITS	DESCRIPTIONS	
[31:16]	DP2	Recommended pattern value for “4'b0010” gray level 0000 0001 0000 0001
[15:0]	DP1	Recommended pattern value for “4'b0001” gray level 0000 0000 0000 0001

Dithering Pattern 2 Register (DITHP2)

REGISTER	ADDRESS	R/W	DESCRIPTION	RESET VALUE
DITHP2	0xFFFF0_8074	R/W	Gray level dithered data duty pattern 2	0x1111_0841

31	30	29	28	27	26	25	24
DP4[15:8]							
23	22	21	20	19	18	17	16
DP4[7:0]							
15	14	13	12	11	10	9	8
DP3[15:8]							
7	6	5	4	3	2	1	0
DP3[7:0]							

BITS	DESCRIPTIONS	
[31:16]	DP4	Recommended pattern value for “4'b0100” gray level 0001 0001 0001 0001
[15:0]	DP3	Recommended pattern value for “4'b0011” gray level 0000 1000 0100 0001



Dithering Pattern 3 Register (DITHP3)

REGISTER	ADDRESS	R/W	DESCRIPTION	RESET VALUE
DITHP3	0xFFFF0_8078	R/W	Gray level dithered data duty pattern 3	0x4949_2491

31	30	29	28	27	26	25	24
DP6[15:8]							
23	22	21	20	19	18	17	16
DP6[7:0]							
15	14	13	12	11	10	9	8
DP5[15:8]							
7	6	5	4	3	2	1	0
DP5[7:0]							

BITS	DESCRIPTIONS	
[31:16]	DP6	Recommended pattern value "4"b0110" gray level 0100 1001 0100 1001
[15:0]	DP5	Recommended pattern value "4"b0101" gray level 0010 0100 1001 0001

Dithering Pattern 4 Register (DITHP4)

REGISTER	ADDRESS	R/W	DESCRIPTION	RESET VALUE
DITHP4	0xFFFF0_807C	R/W	Gray level dithered data duty pattern 4	0x5555_52A5

31	30	29	28	27	26	25	24
DP8[15:8]							
23	22	21	20	19	18	17	16
DP8[7:0]							
15	14	13	12	11	10	9	8
DP7[15:8]							
7	6	5	4	3	2	1	0
DP7[7:0]							

W90P710CD/W90P710CDG



BITS		DESCRIPTIONS
[31:16]	DP8	Recommended pattern value "4"b1000" gray level 0101 0101 0101 0101
[15:0]	DP7	Recommended pattern value "4"b0111" gray level 0101 0010 1010 1001

Dithering Pattern 5 Register (DITHP5)

REGISTER	ADDRESS	R/W	DESCRIPTION	RESET VALUE
DITHP5	0xFFFF0_8080	R/W	Gray level dithered data duty pattern 5	0xB6B6_B556

31	30	29	28	27	26	25	24
DP10[15:8]							
23	22	21	20	19	18	17	16
DP10[7:0]							
15	14	13	12	11	10	9	8
DP9[15:8]							
7	6	5	4	3	2	1	0
DP9[7:0]							

BITS		DESCRIPTIONS
[31:16]	DP10	Recommended pattern value "4"b1010" gray level 1011 0110 1011 0110
[15:0]	DP9	Recommended pattern value "4"b1001" gray level 1011 0101 0101 0110

Dithering Pattern 6 Register (DITHP6)

REGISTER	ADDRESS	R/W	DESCRIPTION	RESET VALUE
DITHP6	0xFFFF0_8084	R/W	Gray level dithered data duty pattern 6	0xEEEE_DB6E

W90P710CD/W90P710CDG



31	30	29	28	27	26	25	24
DP12[15:8]							
23	22	21	20	19	18	17	16
DP12[7:0]							
15	14	13	12	11	10	9	8
DP11[15:8]							
7	6	5	4	3	2	1	0
DP11[7:0]							

BITS		DESCRIPTIONS
[31:16]	DP12	Recommended pattern value “4”b1100” gray level 1110 1110 1110 1110
[15:0]	DP11	Recommended pattern value “4”b1011” gray level 1101 1011 0110 1110

Dithering Pattern 7 Register (DITHP7)

REGISTER	ADDRESS	R/W	DESCRIPTION	RESET VALUE
DITHP7	0xFFFF0_8088	R/W	Gray level dithered data duty pattern 7	0xFEFE_EFBE

31	30	29	28	27	26	25	24
DP14[15:8]							
23	22	21	20	19	18	17	16
DP14[7:0]							
15	14	13	12	11	10	9	8
DP13[15:8]							
7	6	5	4	3	2	1	0
DP13[7:0]							

BITS		DESCRIPTIONS
[31:16]	DP14	Recommended pattern value “4”b1110” gray level 1111 1110 1111 1110
[15:0]	DP13	Recommended pattern value “4”b1101” gray level 1110 1111 1011 1110

The 4bpp flow is the same with 2bpp.

W90P710CD/W90P710CDG



PIXEL DATA OF 4BPP IMAGE	THE ADDRESS VALUE WHICH WILL INPUT LOOKUP TABLE SRAM
0 (0000)	LUTENTRY1[7:0]
1 (0001)	LUTENTRY1[15:8]
2 (0010)	LUTENTRY1[23:16]
3 (0011)	LUTENTRY1[31:24]
4 (0100)	LUTENTRY2[7:0]
5 (0101)	LUTENTRY2[15:8]
6 (0110)	LUTENTRY2[23:16]
7 (0111)	LUTENTRY2[31:24]
8 (1000)	LUTENTRY3[7:0]
9 (1001)	LUTENTRY3[15:8]
10 (1010)	LUTENTRY3[23:16]
11 (1011)	LUTENTRY3[31:24]
12 (1100)	LUTENTRY4[7:0]
13 (1101)	LUTENTRY4[15:8]
14 (1110)	LUTENTRY4[23:16]
15 (1111)	LUTENTRY4[31:24]

When the image is 8bpp, the pixel data is directly treated as an SRAM Lookup Table address

STN 16-level gray number & relative Time-based dithering

Frame No	#1	#2	#3	#4	#5	#6	#7	#8	#9	#10	#11	#12	#13	#14	#15	#16
Duty Cycle																
0																
1	✓															
2	✓								✓							
3	✓						✓					✓				
4	✓				✓				✓				✓			
5	✓				✓			✓			✓			✓		
6	✓			✓			✓		✓			✓			✓	
7	✓			✓		✓		✓		✓			✓		✓	
8	✓		✓		✓		✓		✓		✓		✓		✓	
9		✓	✓		✓		✓		✓		✓		✓	✓		✓
10		✓	✓		✓	✓		✓		✓	✓		✓	✓		✓
11		✓	✓	✓		✓	✓		✓	✓		✓	✓		✓	✓
12		✓	✓	✓		✓	✓	✓		✓	✓	✓		✓	✓	✓
13		✓	✓	✓	✓	✓		✓	✓	✓	✓	✓		✓	✓	✓
14		✓	✓	✓	✓	✓	✓	✓		✓	✓	✓	✓	✓	✓	✓
15	✓	✓	✓	✓	✓	✓	✓	✓	✓	✓	✓	✓	✓	✓	✓	✓
Probability	9/16	7/16	8/16	7/16	8/17	7/16	8/16	7/16	8/16	7/16	8/16	7/16	8/16	7/16	8/16	7/16

Symbol "✓" indicates pixel is turned on, otherwise it is off.

W90P710CD/W90P710CDG



6.10.3.6 LCD Post-processing

Dummy Display Color Pattern Register (DDISPCP)

REGISTER	ADDRESS	R/W	DESCRIPTION	RESET VALUE
DDISPCP	0xFFFF0_8090	R/W	Dummy Display Color Pattern	0x0000_0000

31	30	29	28	27	26	25	24
Reserved		GRAY					
23	22	21	20	19	18	17	16
DDISPR							
15	14	13	12	11	10	9	8
DDISPG							
7	6	5	4	3	2	1	0
DDISPB							

BITS	DESCRIPTIONS	
[31]	Reserved	Reserved
[30:24]	GRAY	Replenish bit for 8bpp when LUTEN is disable
[23:16]	DDISPR	LCD dummy display data of R component
[15:8]	DDISPG	LCD dummy display data of G component
[7:0]	DDISPB	LCD dummy display data of B component

Video Windows Starting Coordinate Register (VWINS)

REGISTER	ADDRESS	R/W	DESCRIPTION	RESET VALUE
VWINS	0xFFFF0_8094	R/W	Video Window Starting Coordinate	0x0000_0000

31	30	29	28	27	26	25	24
VWYS[31:24]							
23	22	21	20	19	18	17	16
VWYS[23:16]							
15	14	13	12	11	10	9	8
VWXS[15:8]							
7	6	5	4	3	2	1	0
VWXS[7:0]							

W90P710CD/W90P710CDG



BITS		DESCRIPTIONS
[31:16]	VWYS	Video Window Y-Start A 16-bit value specifies the vertical starting pixel positions of the LCD display window.
[15:0]	VWXS	Video Window X-Start A 16-bit value specifies the horizontal starting pixel positions of the LCD display window.

Video Windows Ending Coordinate Register (VWINE)

REGISTER	ADDRESS	R/W	DESCRIPTION	RESET VALUE
VWINE	0xFFFF0_8098	R/W	Video Window Ending Coordinates	0x0000_0000

31	30	29	28	27	26	25	24
VWYE[31:24]							
23	22	21	20	19	18	17	16
VWYE[23:16]							
15	14	13	12	11	10	9	8
VWXE[15:8]							
7	6	5	4	3	2	1	0
VWXE[7:0]							

BITS		DESCRIPTIONS
[31:16]	VWYE	Video Window Y-End A 16-bit value specifies the vertical last pixel positions of the LCD display window.
[15:0]	VWXE	Video Window X-End A 16-bit value specifies the horizontal last pixel positions of the LCD display window.

OSD Windows Starting Coordinate Register (OSDWINS)

REGISTER	ADDRESS	R/W	DESCRIPTION	RESET VALUE
OSDWINS	0xFFFF0_809C	R/W	OSD Window Starting Coordinates	0x0000_0000

W90P710CD/W90P710CDG



31	30	29	28	27	26	25	24
OSDWYS[15:8]							
23	22	21	20	19	18	17	16
OSDWYS[7:0]							
15	14	13	12	11	10	9	8
OSDWXS[15:8]							
7	6	5	4	3	2	1	0
OSDWXS[7:0]							

BITS		DESCRIPTIONS
[31:16]	OSDWYS	OSD Window Y-Start A 16-bit value specifies the vertical starting pixel positions of the OSD window.
[15:0]	OSDWXS	OSD Window X-Start A 16-bit value specifies the horizontal starting pixel positions of the OSD window.

OSD Windows Ending Coordinate Register (OSDWINE)

REGISTER	ADDRESS	R/W	DESCRIPTION	RESET VALUE
OSDWINE	0xFFFF0_80A0	R/W	OSD Window Ending Coordinates	0x0000_0000

31	30	29	28	27	26	25	24
OSDWYE[15:8]							
23	22	21	20	19	18	17	16
OSDWYE[7:0]							
15	14	13	12	11	10	9	8
OSDWXE[15:8]							
7	6	5	4	3	2	1	0
OSDWXE[7:0]							

BITS		DESCRIPTIONS
[31:16]	OSDWYE	OSD Window Y-End A 16-bit value specifies the vertical last pixel positions of the OSD window.
[15:0]	OSDWXE	OSD Window X-End A 16-bit value specifies the horizontal last pixel positions of the OSD window.

W90P710CD/W90P710CDG



OSD Overlay Control Register (OSDOVCN)

REGISTER	ADDRESS	R/W	DESCRIPTION	RESET VALUE
OSDOVCN	0xFFF0_80A4	R/W	OSD Overlay Control	0x0000_0000

31	30	29	28	27	26	25	24
Reserved							
23	22	21	20	19	18	17	16
BLICNT							
15	14	13	12	11	10	9	8
Reserved						OSDBLI	OSDCKY
7	6	5	4	3	2	1	0
Reserved	VASYNW			OCR1		OCR0	

BITS	DESCRIPTIONS	
[31:24]	Reserved	Reserved
[23:16]	BLICNT	OSD Blinking Cycle Time An 8-bit value specifies the OSD blinking cycle time (unit: Vsync)
[15:10]	Reserved	Reserved
[9]	OSDBLI	OSD Blinking Control 0 = Disable 1 = Enable
[8]	OSDCKY	OSD Color Key Control 0 = Disable 1 = Enable
[7]	Reserved	Reserved
[6:4]	VASYNW	Video Synthesis Weight Synthesized video= [Video x VASYNW+ OSD x (8-VASYNW)]/8
[3:2]	OCR1	Video/OSD overlay control 1 When display region with OSD window, color-key condition match 00 = Display video data 01 = Display OSD data 10 = Display synthesized (Video+OSD) data

W90P710CD/W90P710CDG



Continued

BITS		DESCRIPTIONS
[1:0]	OCR0	Video/OSD overlay control 0 When display region with OSD window, color-key condition un-match 00 = Display video data 01 = Display OSD data 10 = Display synthesized (Video+OSD) data

OSD Overlay Color Key Pattern Register (OSDOVCKP)

REGISTER	ADDRESS	R/W	DESCRIPTION	RESET VALUE
OSDOVCKP	0xFFF0_80A8	R/W	OSD Overlay Color-Key Pattern	0x0000_0000

31	30	29	28	27	26	25	24
Reserved							
23	22	21	20	19	18	17	16
OSDRKYP							
15	14	13	12	11	10	9	8
OSDGKYP							
7	6	5	4	3	2	1	0
OSDBKYP							

BITS	DESCRIPTIONS	
[31:24]	Reserved	Reserved
[23:16]	OSDRKYP	OSD data comparing R component according to the source color format
[15:8]	OSDGKYP	OSD data comparing G component according to the source color format
[7:0]	OSDBKYP	OSD data comparing B component according to the source color format



OSD Overlay Color Key Mask Register (OSDOVCKM)

REGISTER	ADDRESS	R/W	DESCRIPTION	RESET VALUE
OSDOVCKM	0xFFFF0_80AC	R/W	OSD Overlay Color-Key Mask	0x0000_0000

31	30	29	28	27	26	25	24
Reserved							
23	22	21	20	19	18	17	16
OSDRKYM							
15	14	13	12	11	10	9	8
OSDGKYM							
7	6	5	4	3	2	1	0
OSDBKYM							

BITS	DESCRIPTIONS	
[31:24]	Reserved	Reserved
[23:16]	OSDRKYM	For color-key pattern mask of R component according to the source color format
[15:8]	OSDGKYM	For color-key pattern mask of G component according to the source color format
[7:0]	OSDBKYM	For color-key pattern mask of B component according to the source color format



6.10.3.7 LCD Timing Generation

LCD Timing Control 1 Register (LCDTCON1)

REGISTER	ADDRESS	R/W	DESCRIPTION	RESET VALUE
LCDTCON1	0xFFFF0_80B0	R/W	LCD Timing Control 1	0x0000_0000

31	30	29	28	27	26	25	24
Reserved		HSPW[9:4]					
23	22	21	20	19	18	17	16
HSPW[3:0]				HBPD[9:6]			
15	14	13	12	11	10	9	8
HBPD[5:0]						HFPD[9:8]	
7	6	5	4	3	2	1	0
HFPD[7:0]							

BITS	DESCRIPTIONS	
[31:30]	Reserved	Reserved
[29:20]	HSPW	Horizontal sync pulse width determines the HSYNC pulse's high level width by counting the number of the VCLK.
[19:10]	HBPD	Horizontal back porch is the number of VCLK periods between the falling edge of HSYNC and the start of active data.
[9:0]	HFPD	Horizontal front porch is the number of VCLK periods between the end of active data and the rising edge of HSYNC.

LCD Timing Control 2 Register (LCDTCON2)

REGISTER	ADDRESS	R/W	DESCRIPTION	RESET VALUE
LCDTCON2	0xFFFF0_80B4	R/W	LCD Timing Control 2	0x0000_0000

W90P710CD/W90P710CDG



31	30	29	28	27	26	25	24
PPL[15:8]							
23	22	21	20	19	18	17	16
PPL[7:0]							
15	14	13	12	11	10	9	8
LPP[15:8]							
7	6	5	4	3	2	1	0
LPP[7:0]							

BITS	DESCRIPTIONS	
[31:16]	PPL	Pixel Per-Line The PPL bit field specifies the number of pixels in each line or row of screen.
[15:0]	LPP	Lines Per-Panel The LPP bit field specifies the number of active lines per screen.

LCD Timing Control 3 Register (LCDTCON3)

REGISTER	ADDRESS	R/W	DESCRIPTION	RESET VALUE
LCDTCON3	0xFFFF0_80B8	R/W	LCD Timing Control Register 3	0x0000_0000

31	30	29	28	27	26	25	24
Reserved		VSPW[9:4]					
23	22	21	20	19	18	17	16
VSPW[3:0]				VBPD[9:6]			
15	14	13	12	11	10	9	8
VBPD[5:0]						VFPD[9:8]	
7	6	5	4	3	2	1	0
VFPD[7:0]							

W90P710CD/W90P710CDG



BITS	DESCRIPTIONS	
[31:30]	Reserved	Reserved
[29:20]	VSPW	Vertical sync pulse width determines the VSYNC pulse's high level width by counting the number of inactive lines.
[19:10]	VBPD	Vertical back porch is the number of inactive lines at the start of a frame, after vertical synchronization period.
[9:0]	VFPD	Vertical front porch is the number of inactive lines at the end of a frame, before vertical synchronization period.

LCD Timing Control 4 Register (LCDTCON4)

REGISTER	ADDRESS	R/W	DESCRIPTION	RESET VALUE
LCDTCON4	0xFFFF0_80BC	R/W	LCD Timing Control 4	0x0000_0000

31	30	29	28	27	26	25	24
Reserved					PCD[9:7]		
23	22	21	20	19	18	17	16
PCD[6:0]							Reserved
15	14	13	12	11	10	9	8
Reserved							PLLRDY
7	6	5	4	3	2	1	0
LCDPRESC							CLKSEL

BITS	DESCRIPTIONS	
[31:27]	Reserved	Reserved
[26:17]	PCD	The ten-bit PCD field is used to derive the LCD panel clock frequency VCLK from LCD controller clock: $VCLK = LCDCLK / (PCD + 2)$
[16:9]	Reserved	Reserved
[8]	PLLRDY	Indicate LCDC that PLL is ready, can switch pixel clock source to PLL clock
[7:1]	LCDPRESC	These bits pre-scale counter the LCD controller clock $Scale_CLK = PLL_FIN / (2 * (LCDPRESC + 1))$
[0]	CLKSEL	This bit driver the LCD controller clock source. 0 = external PLL clock 1 = AHB Bus clock

W90P710CD/W90P710CDG



LCD Timing Control 5 Register (LCDTCON5)

REGISTER	ADDRESS	R/W	DESCRIPTION	RESET VALUE
LCDTCON5	0xFFF0_80C0	R/W	LCD Timing Control 5	0x0000_0000

31	30	29	28	27	26	25	24
Reserved							
23	22	21	20	19	18	17	16
Reserved			ACBF				
15	14	13	12	11	10	9	8
Reserved							
7	6	5	4	3	2	1	0
Reserved			MMODE	INVVCLK	INVHSYN	INVVSYN	INVVDEN

BITS	DESCRIPTIONS	
[31:21]	Reserved	Reserved
[20:16]	ACBF	Determine the toggle rate of the VDEN AC bias pin). The AC bias pin frequency is only applicable to STN display. Program this field with the number of line clocks between each toggle.
[15:5]	Reserved	Reserved
[4]	MMODE	Determine the toggle rate of the VDEN 0 = Each Frame 1 = The rate defined by the ACBF.
[3]	INVVCLK	This bit controls the polarity of the VCLK active edge. 0 = Panel signal is transit at VCLK rising edge 1 = Panel signal is transit at VCLK falling edge
[2]	INVHSYNC	This bit indicates the HSYNC pulse polarity. 0 = Normal 1 = Inverted
[1]	INVVSYNC	This bit indicates the VSYNC pulse polarity. 0 = Normal 1 = Inverted
[0]	INVVDEN	This bit indicates the VDEN signal polarity. 0 = Normal 1 = Inverted



LCD Timing Control 6 Register (LCDTCON6)

REGISTER	ADDRESS	R/W	DESCRIPTION	RESET VALUE
LCDTCON6	0xFFFF0_80C4	R	LCD Timing Control 6	0x0000_0000

31	30	29	28	27	26	25	24
PPLCURENT[15:8]							
23	22	21	20	19	18	17	16
PPLCURENT[7:0]							
15	14	13	12	11	10	9	8
LPPCURENT[15:8]							
7	6	5	4	3	2	1	0
LPPCURENT[7:0]							

BITS	DESCRIPTIONS	
[31:16]	PPLCURENT	Pixel number which LCD Controller is outputting to LCD Panel
[15:0]	LPPCURENT	Line number which LCD Controller is outputting to LCD Panel

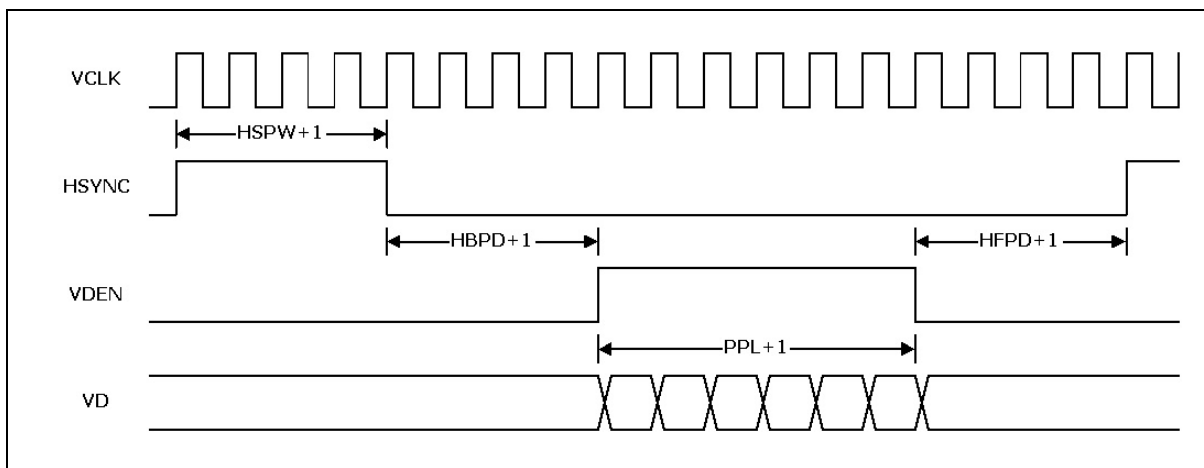

Fig. 6.10.3.7.1 TFT Horizontal display timing diagram

W90P710CD/W90P710CDG

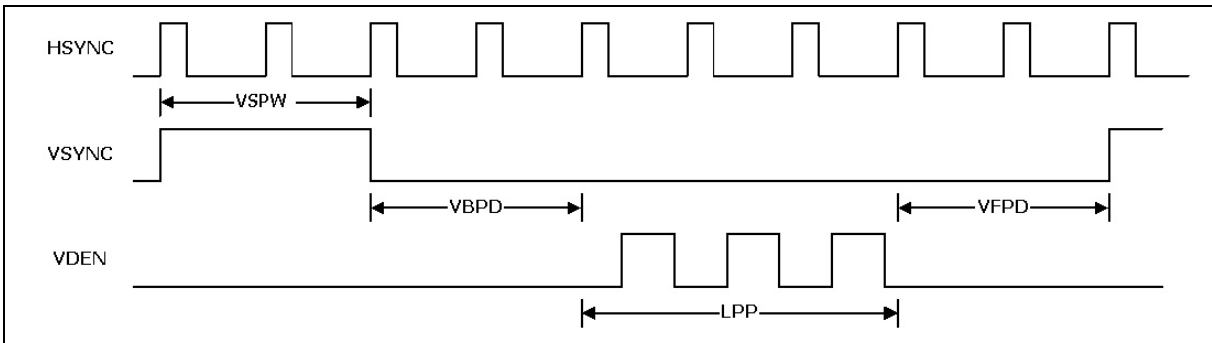

Fig. 6.10.3.7.2 TFT Vertical display timing diagram

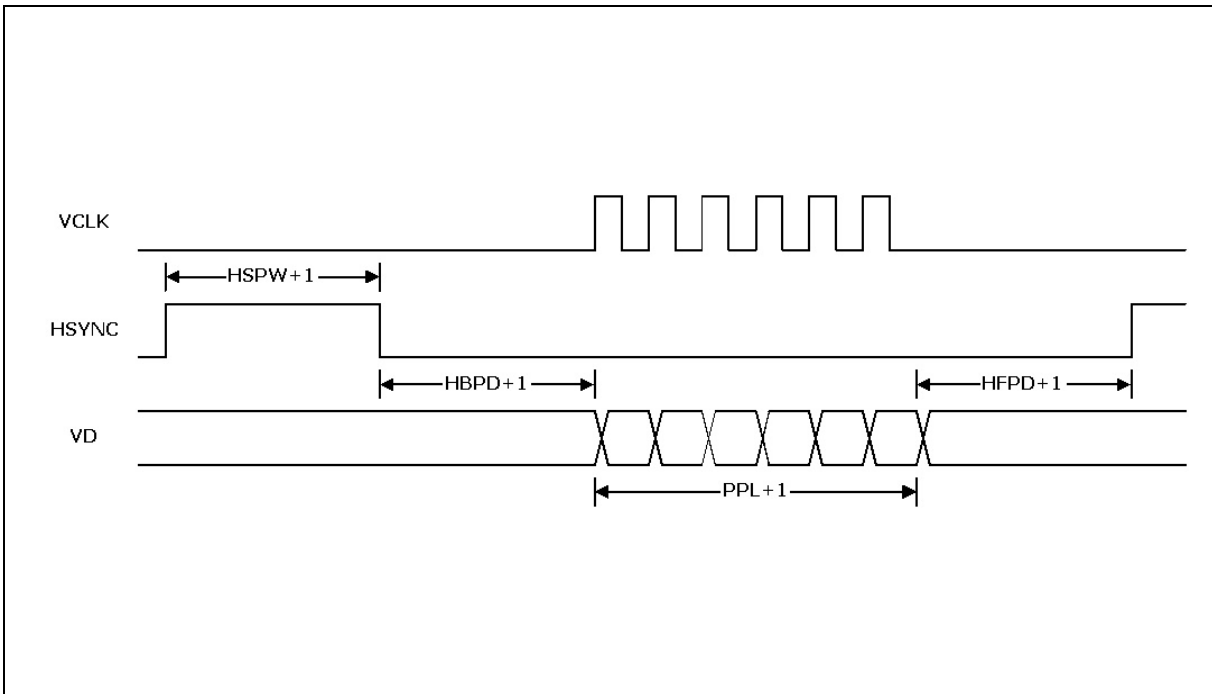

Fig. 6.10.3.7.3 STN Horizontal display timing diagram

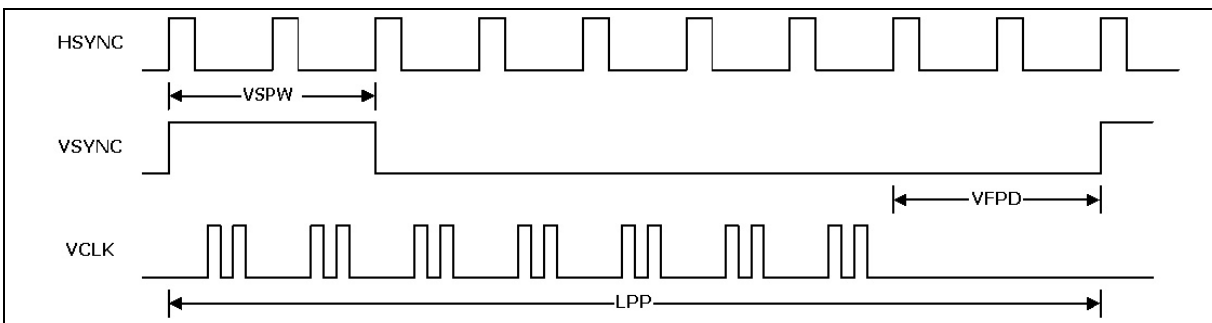

Fig. 6.10.3.7.4 STN Vertical display timing diagram



6.10.3.8 Palette SRAM Built-In Self-Test

Lookup Table SRAM Built-In Self Test Register (BIST)

REGISTER	ADDRESS	R/W	DESCRIPTION	RESET VALUE
BIST	0xFFFF0_80D0	R/W	Lookup Table SRAM Build In Self Test	0x0000_0000

31	30	29	28	27	26	25	24
Reserved							
23	22	21	20	19	18	17	16
Reserved							
15	14	13	12	11	10	9	8
Reserved							
7	6	5	4	3	2	1	0
Reserved					FAIL	FINISH	BISTEN

BITS	DESCRIPTIONS	
[31:3]	Reserved	Reserved
[2]	FAIL	BIST Fail indicator 0 = SRAM BIST not fail 1 = SRAM BIST fail
[1]	FINISH	BIST Finish Status (Read Only) 0 = When BIST enabled, this value means BIST not finished 1 = When BIST enabled, this value means BIST finished, and FAIL can be referenced
[0]	BISTEN	BIST Mode Enable 0 = SRAM is in normal operation. 1 = BIST enabled, SRAM is under BIST test



6.11 Audio Controller

The audio controller consists of IIS/AC-link protocol to interface with external audio CODEC.

One 8-level deep FIFO for read path and write path and each level has 32-bit width (16 bits for the right channel and 16 bits for the left channel). One DMA controller handles the data movement between FIFO and memory.

The following are the properties of DMA.

- Always 8-beat incrementing burst
- Locks the bus during 8-beat incrementing burst
- When reaching the middle and end address of the destination address, a DMA_IRQ is automatically requested for the CPU

An AHB master port and an AHB slave port are available in the audio controller.

6.11.1 IIS Interface

The IIS interface signals are shown as figure 6.11.2.1

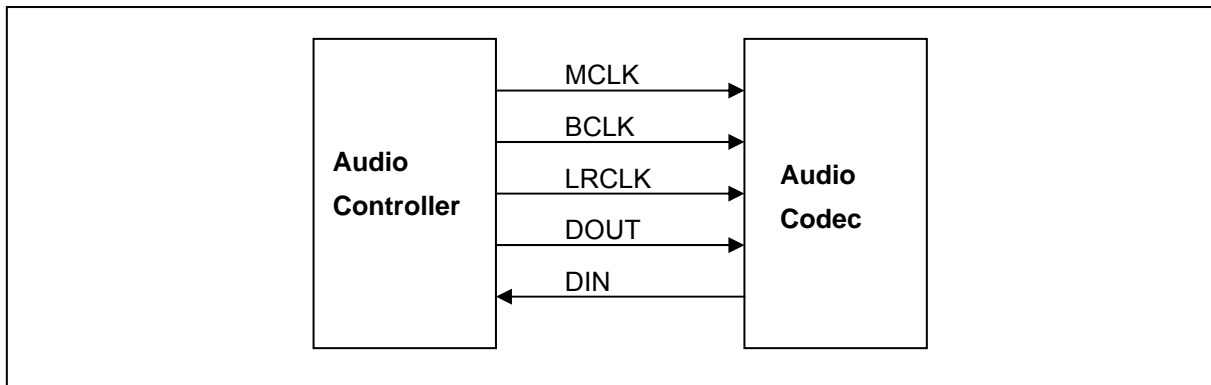

Figure 6.11.2.1 The interface signal of IIS

The 16 bits IIS and MSB-justified format are supported, the timing diagram is shown as Figure 6.11.2.2

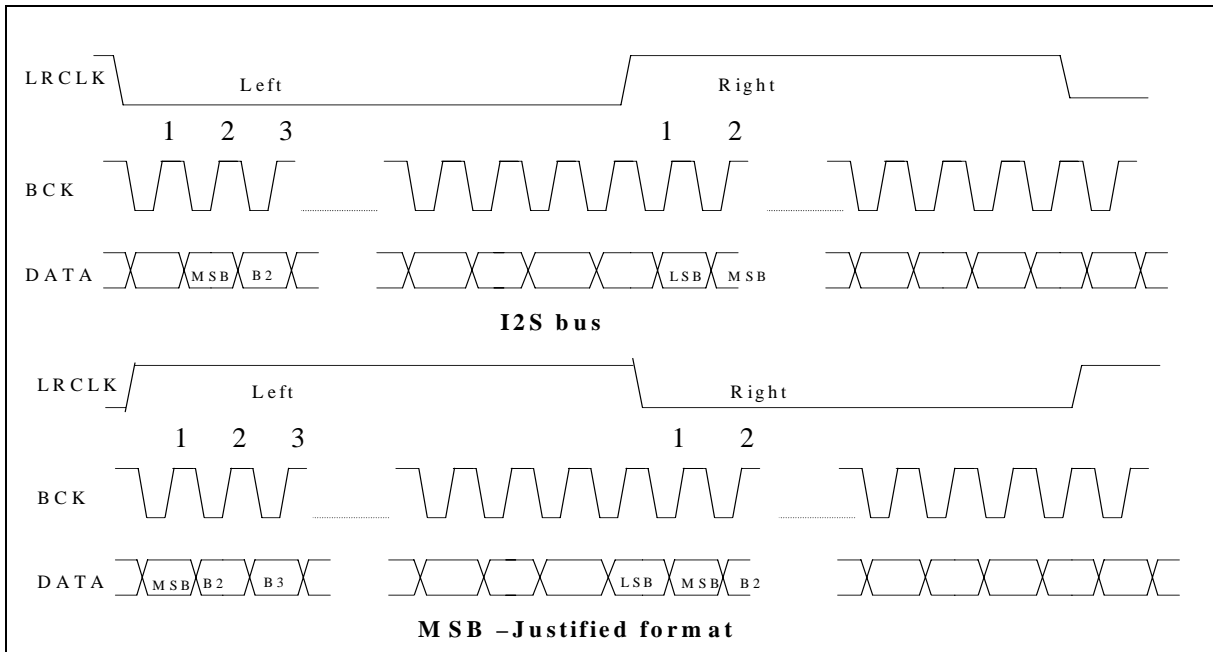

Figure 6.11.2.2 The format of IIS

The sampling rate and bit shift clock frequency can be set by the control register ACTL_IISCON.

6.11.2 AC97 Interface

The AC97 interface, called AC-link is supported. For input and output direction, each frame contains a Tag slot and 12 data slots. However, in the 12 data slots, **only 4 slots are used in W90P710**, other 8 slots are not supported, and the control data and audio data are transferred into 4 valid slots. Each slot contains 20 data bits.

The interface signals are shown as Figure 6.11.2.1

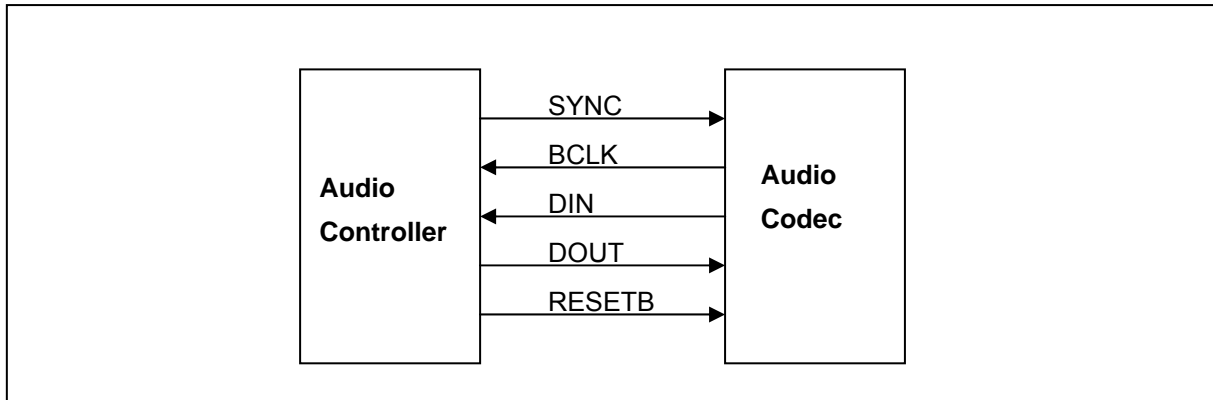
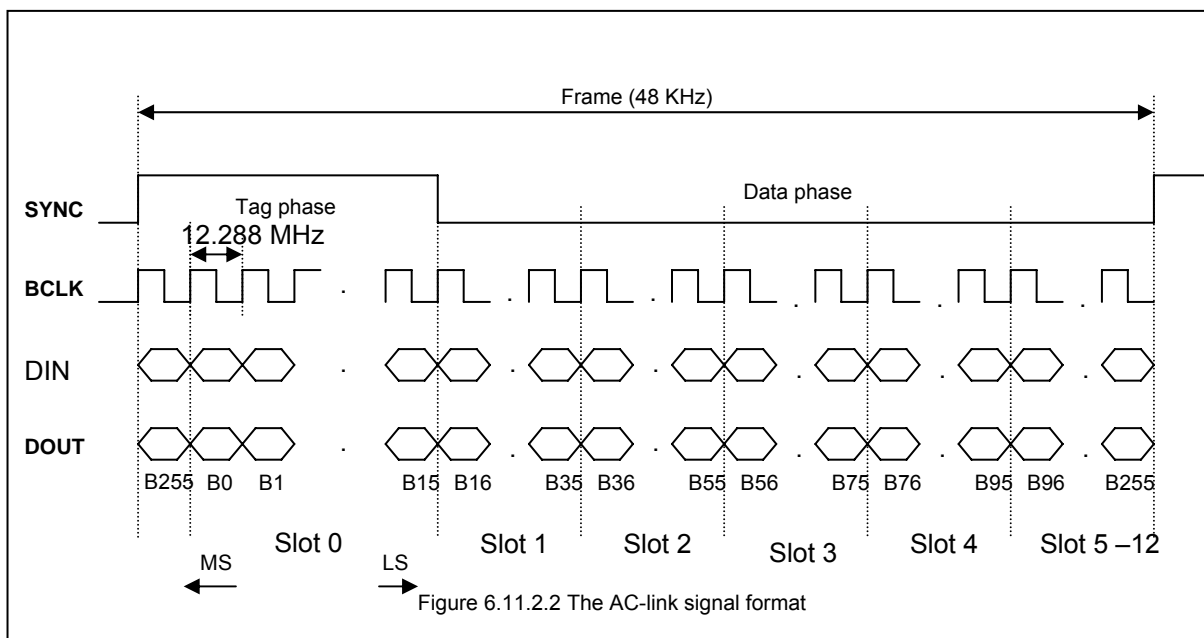

Figure 6.11.2.1 The AC-link interface signal

W90P710CD/W90P710CDG



The signal format is shown as Figure 6.11.2.2



The output frame structure is shown as below:

SLOT #	0	1	2	3	4	5	6	7	8	9	10	11	12
CONTENT	Tag	CMD ADDR	CMD DATA	PCM LEFT	PCM RIGHT	Unused							
BITS	15-0	19-0	19-0	19-0	19-0	159 - 0							
PHASE	Tag phase	Data phase											

The output frame data format is shown as follows:

SLOT #	BIT	DESCRIPTION
Tag (slot 0)	15	Frame validity bit; 1 is valid, 0 is invalid.
	14 - 3	Slot validity, but in W90P710, only bits 6-3 are used, bits 14-7 are unused. Bit 3 corresponds to slot 1, bit 4 corresponds to slot 2, etc. 1 is valid, 0 is invalid. The unused bits 14-7 should be cleared to 0.
	2 - 0	This field should be cleared to 0.
CMD DATA (slot 2)	19 - 4	Control register writes data. It should be cleared to 0 if current operation is read.
	3 - 0	This field should be cleared to 0

W90P710CD/W90P710CDG



Continued.

SLOT #	BIT	DESCRIPTION
PCM LEFT (slot 3)	19 - 4	PCM playback data for left channel
	3 - 0	This field should be cleared to 0
PCM RIGHT (slot 4)	19 - 4	PCM playback data for right channel
	3 - 0	This field should be cleared to 0

The input frame structure is shown as below:

Slot #	0	1	2	3	4	5	6	7	8	9	10	11	12
Content	Tag	status ADDR	status DATA	PCM LEFT	PCM RIGHT	Unused							
Bits	0-15	19-0	19-0	19-0	19-0	159 - 0							

The input frame data format is shown as follows:

SLOT #	BIT	DESCRIPTION
Tag (slot 0)	15	Frame validity bit, 1 is valid, 0 is invalid.
	14 - 3	Slot validity, but in W90P710, only bits 6-3 are used, bits 14-7 are unused. Bit 3 corresponds to slot 1, bit 4 corresponds to slot 2, etc. 1 is valid, 0 is invalid. The unused bits 14-7 should be cleared to 0.
	2 - 0	This field should be cleared to 0.
Status ADDR (slot 1)	19	This bit should be cleared to 0
	18-12	Control register address echo which previous frame requested
	11	PCM data for left channel request, it should be always 0 when VRA=0 (VRA: Variable Rate Audio mode).
	10	PCM data for right channel request (Same as Bit 11).
	9 - 0	This field should be cleared to 0
Status DATA (slot 2)	19 - 4	Control register read data requested by the previous frame. Should be cleared to 0 if this slot is invalid.
	3 - 0	This field should be cleared to 0
PCM LEFT (slot 3)	19 - 4	PCM record data for left channel
	3 - 0	This field should be cleared to 0
PCM RIGHT (slot 4)	19 - 4	PCM record data for right channel
	3 - 0	This field should be cleared to 0



6.11.3 Audio Controller Register Map

R: read only, W: write only, R/W: both read and write, C: Only value 0 can be written

REGISTER	ADDRESS	R/W	DESCRIPTION	RESET VALUE
ACTL_CON	0xFFFF0_9000	R/W	Audio controller control register	0x0000_0000
ACTL_RESET	0xFFFF0_9004	R/W	Sub block reset control register	0x0000_0000
ACTL_RDSTB	0xFFFF0_9008	R/W	DMA destination base address register for record	0x0000_0000
ACTL_RDST_LENGTH	0xFFFF0_900C	R/W	DMA destination length register for record	0x0000_0000
ACTL_RDSTC	0xFFFF0_9010	R	DMA destination current address register for record	0x0000_0000
ACTL_RSR	0xFFFF0_9014	R/W	Record status register	0x0000_0000
ACTL_PDSTB	0xFFFF0_9018	R/W	DMA destination base address register for play	0x0000_0000
ACTL_PDST_LENGTH	0xFFFF0_901C	R/W	DMA destination length register for play	0x0000_0000
ACTL_PDSTC	0xFFFF0_9020	R	DMA destination current address register for play	0x0000_0000
ACTL_PSR	0xFFFF0_9024	R/W	Play status register	0x0000_0004
ACTL_IISCON	0xFFFF0_9028	R/W	IIS control register	0x0000_0000
ACTL_ACCON	0xFFFF0_902C	R/W	AC-link control register	0x0000_0000
ACTL_ACOS0	0xFFFF0_9030	R/W	AC-link out slot 0	0x0000_0000
ACTL_ACOS1	0xFFFF0_9034	R/W	AC-link out slot 1	0x0000_0080
ACTL_ACOS2	0xFFFF0_9038	R/W	AC-link out slot 2	0x0000_0000
ACTL_ACIS0	0xFFFF0_903C	R	AC-link in slot 0	0x0000_0000
ACTL_ACIS1	0xFFFF0_9040	R	AC-link in slot 1	0x0000_0000
ACTL_ACIS2	0xFFFF0_9044	R	AC-link in slot 2	0x0000_0000

Audio controller control registers (ACTL_CON)

REGISTER	ADDRESS	R/W	DESCRIPTION	RESET VALUE
ACTL_CON	0xFFFF0_9000	R/W	Audio controller control register	0x0000_0000

The ACTL_CON register controls the basic operations of the audio controller.

W90P710CD/W90P710CDG



31	30	29	28	27	26	25	24
23	22	21	20	19	18	17	16
15	14	13	12	11	10	9	8
Reserved	Reserved	Reserved	R_DMA_IRQ	T_DMA_IRQ	Reserved		IIS_AC_PIN_SEL
7	6	5	4	3	2	1	0
FIFO_TH	Reserved	Reserved			BLOCK_EN[1:0]		Reserved

BITS	DESCRIPTIONS	
[15]	Reserved	-
[14]	Reserved	-
[13]	Reserved	-
[12]	R_DMA_IRQ	<p>When recording and the DMA current destination address reaches the DMA destination end address or middle address, the R_DMA_IRQ bit is automatically set to 1. The CPU can clear this bit. The bit is hardwired to ARM as interrupt a request signal with an inverter.</p> <p>The R_DMA_IRQ bit is read/write (write 1 to clear)</p>
[11]	T_DMA_IRQ	<p>Transmit DMA interrupt request bit. When DMA current address reaches the middle address $((ACTL_DESE - ACTL_DESB) - 1) / 2 + ACTL_DESB$ or reaches the end address ACTL_DESB, the bit T_DMA_IRQ is set to 1, and the CPU can clear this bit to 0 by writing 1. The bit is hardwired into ARM as interrupt request signal with an inverter.</p> <p>The T_DMA_IRQ bit is read/write (write 1 to clear).</p>
[8]	IIS_AC_PIN_SEL	<p>IIS or AC-link pin selection</p> <ul style="list-style-type: none"> If IIS_AC_PIN_SEL = 0, the pin select IIS If IIS_AC_PIN_SEL = 1, the pin select AC-link <p>The IIS_AC_PIN_SEL bit is read/write</p>
[7]	FIFO_TH	<p>FIFO threshold control bit</p> <ul style="list-style-type: none"> If FIFO_TH=0, the FIFO threshold is 8 level If FIFO_TH=1, the FIFO threshold is 4 level <p>The FIFO_TH bit is read/write</p>
[6]	Reserved	

W90P710CD/W90P710CDG



Continued.

BITS	DESCRIPTIONS	
[2:1]	BLOCK_EN[1:0]	Audio interface type selection <ul style="list-style-type: none"> • If BLOCK_EN[0]=0/1, IIS interface is disable/enable • If BLOCK_EN[1]=0/1, AC-link interface is disable/enable The BLOCK_EN[1:0] bits are read/write
[0]	Reserved	

Sub-block reset control register (ACTL_RESET)

REGISTER	ADDRESS	R/W	DESCRIPTION	RESET VALUE
ACTL_RESET	0xFFFF0_9004	R/W	Sub block reset control	0x0000_0000

The value in ACTL_RESET register controls the reset operation for each sub block.

31	30	29	28	27	26	25	24
23	22	21	20	19	18	17	16
							ACTL_RESET
15	14	13	12	11	10	9	8
RECORD_SINGLE[1:0]		PLAY_SINGLE[1:0]		Reserved			AC_RECORD
7	6	5	4	3	2	1	0
AC_PLAY	IIS_RECORD	IIS_PLAY	Reserved			AC_RESET	IIS_RESET

BITS	DESCRIPTIONS	
[31:17]	Reserved	-
[16]	ACTL_RESET	Audio controller reset control bit 1 = the whole audio controller is reset 0 = the audio controller is normal operation The ACTL_RESET bit is read/write
[15:14]	RECORD_SINGLE [1:0]	Record single/dual channel select bits 2'b11= the record is dual channel 2'b01= the record only select left channel 2'b10= the record only select right channel 2'b00 is reserved Note that, when ADC is selected as a record path, it only supports the left channel record. The PLAY_SINGLE [1:0] bits are read/write



Continued.

BITS	DESCRIPTIONS	
[13:12]	PLAY_SINGLE [1:0]	Playback single/dual channel select bits PLAY_SINGLE [1:0]=11, the playback is in stereo mode PLAY_SINGLE [1:0]=10, the playback is in mono mode PLAY_SINGLE [1:0]= 00 & 01 is reserved The PLAY_SINGLE [1:0] bits are read/write
[8]	AC_RECORD	AC link record control bit AC_RECORD=0, the record path of AC link is disable AC_RECORD=1, the record path of AC link is enable The AC_RECORD bit is read/write
[7]	AC_PLAY	AC link playback control bit AC_PLAY=0, the playback path of AC link is disable AC_PLAY=1, the playback path of AC link is enable The AC_PLAY bit is read/write
[6]	IIS_RECORD	IIS record control bit IIS_RECORD=0, the record path of IIS is disable IIS_RECORD=1, the record path of IIS is enable The IIS_RECORD bit is read/write
[5]	IIS_PLAY	IIS playback control bit IIS_PLAY=0, the playback path of IIS is disable IIS_PLAY=1, the playback path of IIS is enable The IIS_PLAY bit is read/write
[1]	AC_RESET	AC link sub block RESET control bit AC_RESET=0, release the AC link function block from reset mode AC_RESET=1, force the AC link function block to reset mode The AC_RESET bit is read/write
[0]	IIS_RESET	IIS sub block RESET control bit IIS_RESET=0, release the IIS function block from reset mode IIS_RESET=1, force the IIS function block to reset mode The IIS_RESET bit is read/write

DMA record destination base address (ACTL_RDSTB)

REGISTER	ADDRESS	R/W	DESCRIPTION	RESET VALUE
ACTL_RDSTB	0xFFF0_9008	R/W	DMA record destination base address	0x0000_0000

The value in the ACTL_RDSTB register is the DMA record destination base address and can only be changed by the CPU.

W90P710CD/W90P710CDG



31	30	29	28	27	26	25	24
AUDIO_RDSTB[31:24]							
23	22	21	20	19	18	17	16
AUDIO_RDSTB[23:16]							
15	14	13	12	11	10	9	8
AUDIO_RDSTB[15:8]							
7	6	5	4	3	2	1	0
AUDIO_RDSTB[7:0]							

BITS	DESCRIPTIONS	
[31:0]	AUDIO_RDSTB[31:0]	32-bit record destination base address The AUDIO_RDSTB[31:0] bits is read/write.

DMA destination end address (ACTL_RDST_LENGTH)

REGISTER	ADDRESS	R/W	DESCRIPTION	RESET VALUE
ACTL_RDST_LENGTH	0xFFFF0_900C	R/W	DMA record destination address length	0x0000_0000

The value in ACTL_RDST_LENGTH register is the record destination address length of DMA, and only the CPU can change the register.

31	30	29	28	27	26	25	24
AUDIO_RDST_L[31:24]							
23	22	21	20	19	18	17	16
AUDIO_RDST_L[23:16]							
15	14	13	12	11	10	9	8
AUDIO_RDST_L[15:8]							
7	6	5	4	3	2	1	0
AUDIO_RDST_L[7:0]							

BITS	DESCRIPTIONS	
[31:0]	AUDIO_RDST_L[31:0]	32-bit record destination address length The AUDIO_RDST_L[31:0] bits is read/write.



DMA destination current address (ACTL_RDSTC)

REGISTER	ADDRESS	R/W	DESCRIPTION	RESET VALUE
ACTL_RDSTC	0xFFFF0_9010	RO	DMA record destination current address	0x0000_0000

The value in ACTL_RDSTC is the DMA record destination current address. Only the CPU can read this register.

31	30	29	28	27	26	25	24
AUDIO_RDSTC[31:24]							
23	22	21	20	19	18	17	16
AUDIO_RDSTC[23:16]							
15	14	13	12	11	10	9	8
AUDIO_RDSTC[15:8]							
7	6	5	4	3	2	1	0
AUDIO_RDSTC[7:0]							

BITS	DESCRIPTIONS	
[31:0]	AUDIO_RDSTC[31:0]	32-bit record destination current address The AUDIO_RDSTC[31:0] bits is read only.

Audio controller record status register (ACTL_RSR)

REGISTER	ADDRESS	R/W	DESCRIPTION	RESET VALUE
ACTL_RSR	0xFFFF0_9014	R/W	Audio controller FIFO and DMA status register for record	0x0000_0000

31	30	29	28	27	26	25	24
Reserved							
23	22	21	20	19	18	17	16
Reserved							
15	14	13	12	11	10	9	8
Reserved							
7	6	5	4	3	2	1	0
Reserved					R_FIFO_ FULL	R_DMA_END_ IRQ	R_DMA_MIDDLE_ IRQ



BITS		DESCRIPTIONS
[31:3]	Reserved	-
[2]	R_FIFO_FULL	Record FIFO full indicator bit R_FIFO_FULL=0, the record FIFO not full R_FIFO_FULL=1, the record FIFO is full The R_FIFO_READY bit is read only
[1]	R_DMA_END_IRQ	DMA end address interrupt request bit for record R_DMA_END_IRQ=0, means record DMA address does not reach the end address R_DMA_END_IRQ=1, means record DMA address reach the end address The R_DMA_END_IRQ bit is readable, and only can be clear by write 1 to this bit
[0]	R_DMA_MIDDLE_IRQ	DMA address interrupt request bit for record R_DMA_MIDDLE_IRQ=0, means record DMA address does not reach the middle address R_DMA_MIDDLE_IRQ=1, means record DMA address reach the middle address The R_DMA_MIDDLE_IRQ bit is readable, and only can be clear by write 1 to this bit

DMA play destination base address (ACTL_PDSTB)

REGISTER	ADDRESS	R/W	DESCRIPTION	RESET VALUE
ACTL_PDSTB	0xFFFF0_9018	R/W	DMA play destination base address	0x0000_0000

The value in ACTL_PDSTB register is the DMA play destination base address, which can only be changed by the CPU.

31	30	29	28	27	26	25	24
AUDIO_PDSTB[31:24]							
23	22	21	20	19	18	17	16
AUDIO_PDSTB[23:16]							
15	14	13	12	11	10	9	8
AUDIO_PDSTB[15:8]							
7	6	5	4	3	2	1	0
AUDIO_PDSTB[7:0]							

BITS	DESCRIPTIONS
------	--------------

W90P710CD/W90P710CDG



[31:0]	AUDIO_PDSTB[31:0]	32-bit play destination base address The AUDIO_PDSTB[31:0] bits is read/write.
--------	--------------------------	---

DMA destination end address (ACTL_PDST_LENGTH)

REGISTER	ADDRESS	R/W	DESCRIPTION	RESET VALUE
ACTL_PDST_LENGTH	0xFFFF0_901C	R/W	DMA play destination address length	0x0000_0000

The value in ACTL_PDST_LENGTH register is the play destination address length of DMA, which can only be changed by the CPU.

31	30	29	28	27	26	25	24
AUDIO_PDST_L[31:24]							
23	22	21	20	19	18	17	16
AUDIO_PDST_L[23:16]							
15	14	13	12	11	10	9	8
AUDIO_PDST_L[15:8]							
7	6	5	4	3	2	1	0
AUDIO_PDST_L[7:0]							

BITS	DESCRIPTIONS	
[31:0]	AUDIO_PDST_L[31:0]	32-bit play destination address length The AUDIO_PDST_L[31:0] bits is read/write.

DMA destination current address (ACTL_PDSTC)

REGISTER	ADDRESS	R/W	DESCRIPTION	RESET VALUE
ACTL_PDSTC	0xFFFF0_9020	RO	DMA play destination current address	0x0000_0000

The value in ACTL_PDSTC is the DMA play destination current address, this register can only be read by the CPU.

W90P710CD/W90P710CDG



31	30	29	28	27	26	25	24
AUDIO_PDSTC[31:24]							
23	22	21	20	19	18	17	16
AUDIO_PDSTC[23:16]							
15	14	13	12	11	10	9	8
AUDIO_PDSTC[15:8]							
7	6	5	4	3	2	1	0
AUDIO_PDSTC[7:0]							

BITS	DESCRIPTIONS	
[31:0]	AUDIO_PDSTC[31:0]	32-bit play destination current address The AUDIO_PDSTC[31:0] bits is read/write.

Audio controller playback status register (ACTL_PSR)

REGISTER	ADDRESS	R/W	DESCRIPTION	RESET VALUE
ACTL_PSR	0xFFFF0_9024	R/W	Audio controller FIFO and DMA status register for playback	0x0000_0004

31	30	29	28	27	26	25	24
Reserved							
23	22	21	20	19	18	17	16
Reserved							
15	14	13	12	11	10	9	8
Reserved							
7	6	5	4	3	2	1	0
Reserved				P_FIFO_EMPTY	P_DMA_END_IRQ	P_DMA_MIDDLE_IRQ	



BITS	DESCRIPTIONS	
[31:3]	Reserved	-
[2]	P_FIFO_EMPTY	Playback FIFO empty indicator bit P_FIFO_EMPTY=0, the playback FIFO is not empty P_FIFO_EMPTY=1, the playback FIFO is empty The P_FIFO_EMPTY bit is read only
[1]	P_DMA_END_IRQ	DMA end address interrupt request bit for playback P_DMA_END_IRQ=0, means playback DMA address does not reach the end address P_DMA_END_IRQ=1, means playback DMA address reach the end address The P_DMA_END_IRQ bit is readable, and only can be clear by write 1 to this bit
[0]	P_DMA_MIDDLE_IRQ	DMA address interrupt request bit for playback P_DMA_MIDDLE_IRQ=0, means playback DMA address does not reach the middle address P_DMA_MIDDLE_IRQ=1, means playback DMA address reach the middle address The P_DMA_MIDDLE_IRQ bit is readable, and only can be clear by write 1 to this bit

IIS control register (ACTL_IISCON)

REGISTER	ADDRESS	R/W	DESCRIPTION	RESET VALUE
ACTL_IISCON	0xFFFF0_9028	R/W	IIS control register	0x0000_0000

The ACTL_IISCON is the IIS basic operation control register.

31	30	29	28	27	26	25	24
Reserved							
23	22	21	20	19	18	17	16
Reserved				PRS[3:0]			
15	14	13	12	11	10	9	8
Reserved							
7	6	5	4	3	2	1	0
BCLK_SEL[1:0]		FS_SEL	MCLK_SEL	FORMAT	Reserved		

W90P710CD/W90P710CDG



BITS	DESCRIPTIONS	
[31:20]	Reserved	-
[19:16]	PRS[3:0]	<p>IIS frequency prescaler selection bits. (FPLL is the input PLL frequency, MCLK is the output main clock)</p> <p>PSR[3:0]=0000, MCLK=FPLL/1 PSR[3:0]=0001, MCLK=FPLL/2 PSR[3:0]=0010, MCLK=FPLL/3 PSR[3:0]=0011, MCLK=FPLL/4 PSR[3:0]=0100, MCLK=FPLL/5 PSR[3:0]=0101, MCLK=FPLL/6 PSR[3:0]=0110, MCLK=FPLL/7 PSR[3:0]=0111, MCLK=FPLL/8 PSR[3:0]=1000, reserved PSR[3:0]=1001, MCLK=FPLL/10 PSR[3:0]=1010, reserved PSR[3:0]=1011, MCLK=FPLL/12 PSR[3:0]=1100, reserved PSR[3:0]=1101, MCLK=FPLL/14 PSR[3:0]=1110, reserved PSR[3:0]=1111, MCLK=FPLL/16</p> <p>(when the division factor is 3/5/7, the duty cycle of MCLK is not 50%, the high duration is 0.5*FPLL)</p> <p>The PSR[3:0] bits are read/write</p>
[7:6]	BCLK_SEL [1:0]	<p>IIS serial data clock frequency selection bit</p> <p>BCLK_SEL[1:0]=00, 32fs is selected (fs is sampling rate), when FS_SEL=0, the frequency of bit clock is MCLK/8, when FS_SEL=1, the frequency of bit clock is MCLK/12.</p> <p>BCLK_SEL[1:0]=01, 48fs is selected (only when FS_SEL=1, this term could be selection), when FS_SEL=1, the frequency of bit clock is MCLK/8.</p> <p>The BCLK_SEL[1:0] bits are read/write</p>
[5]	FS_SEL	<p>IIS sampling frequency selection bit</p> <p>FS_SEL=0, FMCLK/256 is selected (FMCLK is the frequency of signal MCLK)</p> <p>FS_SEL=1, FMCLK/384 is selected</p> <p>The FS_SEL bit is read/write</p>
[4]	MCLK_SEL	<p>IIS MCLK output selection bit</p> <p>MCLK_SEL=0, IIS MCLK output will follow the PRS [3:0] setting.</p> <p>MCLK_SEL=1, IIS MCLK output is the same with FPLL.</p> <p>The MCLK_SEL bit is read/write</p>



Continued

BITS	DESCRIPTIONS	
[3]	FORMAT	IIS format selection bits FORMAT=0, IIS compatible format is selected FORMAT=1, MSB-justified format is selected The FORMAT bit is read/write
[2:0]	Reserved	-

AC-link Control Register (ACTL_ACCON)

REGISTER	ADDRESS	R/W	DESCRIPTION	RESET VALUE
ACTL_ACCON	0xFFF0_902C	R/W	AC-link control register	0x0000_0000

The ACTL_ACCON register is the AC-link basic operation control register.

31	30	29	28	27	26	25	24
Reserved							
23	22	21	20	19	18	17	16
Reserved							
15	14	13	12	11	10	9	8
Reserved							
7	6	5	4	3	2	1	0
Reserved		AC_BCLK_PU_EN	AC_R_FINISH	AC_W_FINISH	AC_W_RES	AC_C_RES	Reserved

BITS	DESCRIPTIONS	
[6]	Reserved	-
[5]	AC_BCLK_PU_EN	This bit controls the AC_BCLK pin pull-high resistor. AC_BCLK_PU_EN=0, the AC_BCLK pin pull-high resistor is disabled AC_BCLK_PU_EN=1, the AC_BCLK pin pull-high resistor is enabled The AC_BCLK_PU_EN bit is read/write.
[4]	AC_R_FINISH	AC-link read data ready bit. When read data indexed by previous frame is shifted into ACTL_ACIS2, the AC_R_FINISH bit is automatically set to 1. After the CPU reads the data, AC_R_FINISH bit is cleared to 0. AC_R_FINISH=0, read data buffer has been read by CPU AC_R_FINISH=1, read data buffer is ready for CPU read The AC_R_FINISH bit is read only

W90P710CD/W90P710CDG



Continued.

BITS	DESCRIPTIONS	
[3]	AC_W_FINISH	<p>AC-link write frame finish bit. When writing data to register ACTL_ACOS0, the AC_W_FINISH bit is set to 1 automatically. After AC-link interface shift out the register ACTL_ACOS0, the AC_W_FINISH bit is cleared to 0.</p> <p>AC_W_FINISH=0, AC-link control data out buffer has been shifted to the codec by the CPU and data buffer is empty.</p> <p>AC_W_FINISH=1, AC-link control data out buffer is ready to be shifted (after the programmer has written the data into register ACTL_ACOS0)</p> <p>The AC_W_FINISH bit is read only</p>
[2]	AC_W_RES	<p>AC-link warm reset control bit. When this bit is set to 1, (AC-link begins the 'warm reset procedure', and then automatically clears this bit) the interface signal AC_SYNC is high, when this bit is set to 0, the interface signal AC_SYNC is controlled by AC_BCLK input when this bit is set to 1. Note the AC-link spec. shows it needs at least 10 us high duration of AC_SYNC to warm reset AC97.</p> <p>AC_W_RES=0, AC_SYNC pin is controlled by AC_BCLK input pin</p> <p>AC_W_RES=1, AC_SYNC pin is forced to high</p> <p>The AC_W_RES bit is read/write</p>
[1]	AC_C_RES	<p>AC-link cold reset control bit, when this bit is set to 1, the interface signal AC_RESETB is low, when this bit is set to 0, the signal AC_RESETB is high. Note the AC-link spec. shows it needs at least 10 us low duration of AC_RESETB to cold reset AC97.</p> <p>AC_C_RES=0, AC_RESETB pin is set to 1</p> <p>AC_C_RES=1, AC_RESETB pin is set to 0</p> <p>The AC_C_RES bit is read/write</p>
[0]	Reserved	-

AC-link output slot 0 (ACTL_ACOS0)

REGISTER	ADDRESS	R/W	DESCRIPTION	RESET VALUE
ACTL_ACOS0	0xFFFF0_9030	R/W	AC-link out slot 0	0x0000_0000

The ACTL_ACOS0 register stores slot 0 value to be shifted by AC-link. Note that writing data to ACTL_ACOS0 register when AC_W_FINISH bit (ACTL_ACCON[3]) is set is invalid. Therefore, **check AC_W_FINISH bit status before write data into ACTL_ACOS0 register.**

W90P710CD/W90P710CDG



31	30	29	28	27	26	25	24
Reserved							
23	22	21	20	19	18	17	16
Reserved							
15	14	13	12	11	10	9	8
Reserved							
7	6	5	4	3	2	1	0
Reserved			VALID_FRAME	SLOT_VALID[3:0]			

BITS	DESCRIPTIONS	
[31:5]	Reserved	-
[4]	VALID_FRAME	Frame valid indicated bits VALID_FRAME=1, any one of slot is valid VALID_FRAME=0, no any slot is valid The VALID_FRAME bits are read/write
[3:0]	SLOT_VALID [3:0]	Slot valid indicated bits SLOT_VALID[0]= 1/0, indicate Slot 1 valid/invalid SLOT_VALID[1]= 1/0, indicate Slot 2 valid/invalid SLOT_VALID[2]= 1/0, indicate Slot 3 valid/invalid SLOT_VALID[3]= 1/0, indicate Slot 4 valid/invalid The SLOT_VALID[3:0] bits are read/write

The AC-link output slot 1 (ACTL_ACOS1)

REGISTER	ADDRESS	R/W	DESCRIPTION	RESET VALUE
ACTL_ACOS1	0xFFFF0_9034	R/W	AC-link out slot 1	0x0000_0080

The ACTL_ACOS1 register stores slot 1 value to be shifted by the AC-link.

W90P710CD/W90P710CDG



31	30	29	28	27	26	25	24
Reserved							
23	22	21	20	19	18	17	16
Reserved							
15	14	13	12	11	10	9	8
Reserved							
7	6	5	4	3	2	1	0
R_WB	R_INDEX [6:0]						

BITS	DESCRIPTIONS	
[31:8]	Reserved	-
[7]	R_WB	Read/Write select bit R_WB=1, a read specified by R_INDEX [6:0] will occur, and the data will appear in the next frame R_WB=0, a write specified by R_INDEX [6:0] will occur, and the write data is put at slot 2 The R_WB bit is read/write
[6:0]	R_INDEX[6:0]	External AC97 CODEC control register index (address) bits The R_INDEX [6:0] bits are read/write

AC-link output slot 2 (ACTL_ACOS2)

REGISTER	ADDRESS	R/W	DESCRIPTION	RESET VALUE
ACTL_ACOS2	0xFFF0_9038	R/W	AC-link out slot 2	0x0000_0000

The ACTL_ACOS2 register store the slot 2 value to be shifted by the AC-link.

31	30	29	28	27	26	25	24
Reserved							
23	22	21	20	19	18	17	16
Reserved							
15	14	13	12	11	10	9	8
WD [15:8]							
7	6	5	4	3	2	1	0
WD [7:0]							

W90P710CD/W90P710CDG



BITS	DESCRIPTIONS	
[31:0]	Reserved	-
[15:0]	WD [15:0]	AC-link write data The WD [15:0] bits are read/write

AC-link input slot 0 (ACTL_ACIS0)

REGISTER	ADDRESS	R/W	DESCRIPTION	RESET VALUE
ACTL_ACIS0	0xFFF0_903C	R	AC-link in slot 0	0x0000_0000

The ACTL_ACIS0 store the shift in slot 0 data of AC-link.

31	30	29	28	27	26	25	24
Reserved							
23	22	21	20	19	18	17	16
Reserved							
15	14	13	12	11	10	9	8
Reserved							
7	6	5	4	3	2	1	0
Reserved			CODEC_READY	SLOT_VALID[3:0]			

BITS	DESCRIPTIONS	
[31:5]	Reserved	-
[4]	CODEC_READY	External AC97 audio CODEC ready bit CODEC_READY=0, indicates external AC97 audio CODEC is not ready CODEC_READY=1, indicates external AC97 audio CODEC is ready The CODEC_READY bit is read only
[3:0]	SLOT_VALID[3:0]	Slot valid indicated bits SLOT_VALID[0]= 1/0, indicate Slot 1 valid/invalid SLOT_VALID[1]= 1/0, indicate Slot 2 valid/invalid SLOT_VALID[2]= 1/0, indicate Slot 3 valid/invalid SLOT_VALID[3]= 1/0, indicate Slot 4 valid/invalid The SLOT_VALID[3:0] bits are read



AC-link input slot 1 (ACTL_ACIS1)

REGISTER	ADDRESS	R/W	DESCRIPTION	RESET VALUE
ACTL_ACIS1	0xFFF0_9040	R	AC-link in slot 1	0x0000_0000

The ACTL_ACIS1 stores the shift in slot 1 data of AC-link.

31	30	29	28	27	26	25	24
Reserved							
23	22	21	20	19	18	17	16
Reserved							
15	14	13	12	11	10	9	8
Reserved							R_INDEX[6]
7	6	5	4	3	2	1	0
R_INDEX[5:0]						SLOT_REQ[1:0]	

BITS	DESCRIPTIONS	
[31:9]	Reserved	-
[8:2]	R_INDEX [6:0]	Register index. The R_INDEX [6:0] echo the register index (address) when a register read has been requested in the previous frame. The R_INDEX [6:0] bits are read only
[1:0]	SLOT_REQ [1:0]	Slot request. Indicates if the external codec need new PCM data that will transfer to the next frame. Any bit in SLOT_REQ [1:0] is set to 1, and indicates the external codec does not need a new sample in the corresponding slot[3:4] of the next frame Any SLOT_REQ [1:0] is clear to 0, indicate external codec need a new sample in the corresponding slot [3:4] of the next frame The SLOT_REQ [1:0] bits are read only



AC-link input slot 2 (ACTL_ACIS2)

REGISTER	ADDRESS	R/W	DESCRIPTION	RESET VALUE
ACTL_ACIS2	0xFFFF0_9044	R	AC-link in slot 2	0x0000_0000

The ACTL_ACIS2 stores the shift in slot 2 data of AC-link.

31	30	29	28	27	26	25	24
Reserved							
23	22	21	20	19	18	17	16
Reserved							
15	14	13	12	11	10	9	8
RD[15:8]							
7	6	5	4	3	2	1	0
RD[7:0]							

BITS	DESCRIPTIONS	
[31:16]	Reserved	-
[15:0]	RD[15:0]	AC-link read data. The RD[15:0] bits are read only



6.12 Universal Asynchronous Receiver/Transmitter Controller

Asynchronous serial communication block includes 4 **UART** blocks and accessory logic. They can be described as follows:

- **UART0**

A general purpose UART that does not include any accessory function.

Clock Source	: 15MHz
UART Type	: general UART,
FIFO Number	: 16-byte receiving FIFO and 16 byte transmitting FIFO
Modem Function	: N/A
Accessory Function	: N/A

- **UART1**

Designed for general-purpose UART or Bluetooth transceiver. It includes a high speed UART block with 64-byte receiving FIFO and 64-byte transmitting FIFO. It includes 3 clock sources: 15M, 30M, and 43.6M. The programmer is free to choose the clock source and divisor number for suitable baud rate.

Clock Source	: 15MHz from external crystal 30MHz, 43.6MHz, 48MHz, 60MHz (optional function for Bluetooth HCI transport layer)
UART Type	: high speed UART,
FIFO Number	: 64-byte receiving FIFO and 64 byte transmitting FIFO
Modem Function	: CTS and RTS (optional for Bluetooth. If they were enabled, TX & RX in UART2 is cut off)
Accessory Function	: Bluetooth (optional)
Baud Rate (max)	: 1.875MHz
I/O pin	: TXD1, RXD1, RTS, CTS (optional)

- **UART2**

Designed for general purpose UART or IrDA SIR. The part of UART includes 16-byte receiving FIFO and 16-byte transmitting FIFO. The UART2 has no modem function. The UART2 block has merely 2 I/O. TXD2/RXD2 of UART2 occupies the same pins with RTS and CTS of UART1. Once the Bluetooth function has been enabled, UART2 should be disabled.

Clock Source	: 15MHz
UART Type	: general UART,
FIFO Number	: 16-byte receiving FIFO and 16 byte transmitting FIFO

W90P710CD/W90P710CDG



Modem Function : N/A
 Accessory Function : IrDA SIR (optional)
 I/O Pin : TXD2, RXD2.
 I/O Pin Share with : UART1 (Bluetooth function)

- **UART3**

A general purpose UART that does not include any accessory function. It shares four I/O pins with AC97/I2S.

Clock Source : 15MHz
 UART Type : general UART
 FIFO Number : 16-byte receiving FIFO and 16 byte transmitting FIFO
 Modem Function : DTR, DSR
 Accessory Function : N/A
 I/O Pin : TXD3, RXD3, DTR, DSR
 I/O Pin Share with : AC97_DATAO, AC97_DATAI, AC97_SYNC, AC97_BITCLK

Table 6.12.1 W90P710 UART features list

BLOCK NUMBER	UART TYPE	CLOCK SOURCE	MODEM FUNCTION SIGNALS	IO PINS	DESIGN TARGET
0	General UART	15M	N/A	TxD0, RxD0	General UART
1	High speed UART	15MHz, 30MHz, 43.6MHz, 48MHz, 60MHz	CTS, RTS	TXD1, RXD1, CTS1, RTS1	General UART/ Bluetooth
2	General UART	15M	N/A	TX2, RX2	General UART/IrDA SIR
3	General UART	15M	DTR, DSR	TXD3, RXD3, DRT3, DSR3	General UART



6.12.1 UART0

UART0 is a general UART block. It has no modem I/O signals. For a more detailed function description, please refer to section 7.12.5 **General UART controller description**

Table 6.12.1.1 UART0 Register Map

REGISTER	ADDRESS	R/W	OTHER CONDITION	RESET VALUE
UART0_RBR	0xFFF8_0000	R	DLAB=0	Undefined
UART0_THR	0xFFF8_0000	W	DLAB=0	Undefined
UART0_IER	0xFFF8_0004	R/W	DLAB=0	0x0000_0000
UART0_DLL	0xFFF8_0000	R/W	DLAB=1	0x0000_0000
UART0_DLM	0xFFF8_0004	R/W	DLAB=1	0x0000_0000
UART0_IIR	0xFFF8_0008	R		0x8181_8181
UART0_FCR	0xFFF8_0008	W		Undefined
UART0_LCR	0xFFF8_000c	R/W		0x0000_0000
Reserved	0xFFF8_0010			
UART0_LSR	0xFFF8_0014	R		0x6060_6060
Reserved	0xFFF8_0018			
UART0_TOR	0xFFF8_001c	R/W		0x0000_0000

6.12.2 UART1

UART1 is designed for general purpose UART or Bluetooth HCI transport layer. It is a high speed UART with 64-byte receive FIFO and 64-byte transmit FIFO. To perform 1.875MHz maximum baud rate, UART1 has 5 clock sources, 15MHz, 30MHz, 43.6MHz, 48MHz, and 60MHz. The first one is from an external 15M-crystal clock and the others are divided from system PLL 480MHz output. For more details about high speed UART, please refer to next section 7.12.6 **High Speed UART controller function description**.

The block UART1 offer 4 I/O signals, TX, RX, CTS, and RTS. CTS and RTS are used as flow control for Bluetooth. CTS and RTS share the same I/O pins with TX and RX in block UART2.



Table 6.12.2.1 UART1 Register Map

REGISTER	ADDRESS	R/W	OTHER CONDITION	RESET VALUE
UART1_RBR	0xFFF8_0100	R	DLAB=0	Undefined
UART1_THR	0xFFF8_0100	W	DLAB=0	Undefined
UART1_IER	0xFFF8_0104	R/W	DLAB=0	0x0000_0000
UART1_DLL	0xFFF8_0100	R/W	DLAB=1	0x0000_0000
UART1_DLM	0xFFF8_0104	R/W	DLAB=1	0x0000_0000
UART1_IIR	0xFFF8_0108	R		0x8181_8181
UART1_FCR	0xFFF8_0108	W		Undefined
UART1_LCR	0xFFF8_010c	R/W		0x0000_0000
UART1_MCR	0xFFF8_0110	R/W		0x0000_0000
UART1_LSR	0xFFF8_0114	R		0x6060_6060
UART1_MSR	0xFFF8_0118	R		0x0000_0000
UART1_TOR	0xFFF8_011c	R/W		0x0000_0000
UART1_UBCR	0xFFF8_0120	R/W		0x0000_0000

UART1 Bluetooth Control Register (UART1_UBCR)

REGISTER	ADDRESS	R/W	DESCRIPTION	RESET VALUE
UART1_UBCR	0xFFF8_0120	R/W	UART 1 Bluetooth Control Register	0x0000_0000

31	30	29	28	27	26	25	24
Reserved							
23	22	21	20	19	18	17	16
Reserved							
15	14	13	12	11	10	9	8
Reserved							
7	6	5	4	3	2	1	0
Reserved					UBCR[2:0]		



BITS	DESCRIPTIONS	
[31:3]	Reserved	-
[2:0]	UBCR	UBCR is a 3 bits register which is used to select a clock source to generate suitable baud rate: 000: 15Mhz from external crystal 100: 30Mhz divided from PLL 480Mhz 101: 43.6Mhz divided from PLL 480Mhz 110: 48Mhz divided from PLL 480Mhz 111: 60Mhz divided from PLL 480Mhz

6.12.3 UART2

UART2 contains 2 features: general UART and IrDA SIR decoder/encoder. UART has no modem function. Please read the spec of section 6.12.5 **General UART controller function description**. The IrDA SIR is described as follows:

Table 6.12.3.1 UART2 Register Map

REGISTER	ADDRESS	R/W	OTHER CONDITION	RESET VALUE
UART2_RBR	0xFFF8_0200	R	DLAB=0	Undefined
UART2_THR	0xFFF8_0200	W	DLAB=0	Undefined
UART2_IER	0xFFF8_0204	R/W	DLAB=0	0x0000_0000
UART2_DLL	0xFFF8_0200	R/W	DLAB=1	0x0000_0000
UART2_DLM	0xFFF8_0204	R/W	DLAB=1	0x0000_0000
UART2_IIR	0xFFF8_0208	R		0x8181_8181
UART2_FCR	0xFFF8_0208	W		Undefined
UART2_LCR	0xFFF8_020C	R/W		0x0000_0000
Reserved	0xFFF8_0210			Undefined
UART2_LSR	0xFFF8_0214	R		0x6060_6060
Reserved	0xFFF8_0218			Undefined
UART2_TOR	0xFFF8_021C	R/W		0x0000_0000
UART2_IRCR	0xFFF8_0220	R/W		0x0000_0040

UART2 IrDA Control Register (UART2_IRCR)

REGISTER	ADDRESS	R/W	DESCRIPTION	RESET VALUE
UART2_IRCR	0xFFFF8_0220	R/W	UART 2 IrDA Control Register	0x0000_0040

31	30	29	28	27	26	25	24
Reserved							
23	22	21	20	19	18	17	16
Reserved							
15	14	13	12	11	10	9	8
Reserved							
7	6	5	4	3	2	1	0
Reserved	INV_RX	INV_TX	Reserved	Reserved	LB	TX_SELECT	IrDA_EN

BITS	DESCRIPTIONS	
[31:7]	Reserved	Reserved
[6]	INV_RX	1: Inverse RX input signal 0: No inversion
[5]	INV_TX	1: Inverse TX output signal 0: No inversion
[4:3]	Reserved	Reserved
[2]	LB	IrDA loop back mode for self-test. 1: enable IrDA loop back mode 0: disable IrDA loop back mode
[1]	TX_SELECT	1: enable IrDA transmitter 0: enable IrDA receiver
[0]	IrDA_EN	1: enable IrDA block 0: disable IrDA block



6.12.4 UART3

UART3 is a general UART block. It has no modem I/O signals.

For more details about general UART functions, please refer to the next section 6.12.5 General UART controller.

Table 6.12.4.1 UART3 register map

REGISTER	ADDRESS	R/W	OTHER CONDITION	RESET VALUE
UART3_RBR	0xFFF8_0300	R	DLAB=0	Undefined
UART3_THR	0xFFF8_0300	W	DLAB=0	Undefined
UART3_IER	0xFFF8_0304	R/W	DLAB=0	0x0000_0000
UART3_DLL	0xFFF8_0300	R/W	DLAB=1	0x0000_0000
UART3_DLM	0xFFF8_0304	R/W	DLAB=1	0x0000_0000
UART3_IIR	0xFFF8_0308	R		0x8181_8181
UART3_FCR	0xFFF8_0308	W		Undefined
UART3_LCR	0xFFF8_030c	R/W		0x0000_0000
UART3_MCR	0xFFF8_0310	R/W		0x0000_0000
UART3_LSR	0xFFF8_0314	R		0x6060_6060
UART3_MSR	0xFFF8_0318	R		0x0000_0000
UART3_TOR	0xFFF8_031c	R/W		0x0000_0000

UART3 Modem Control Register (UART3_MCR)

REGISTER	ADDRESS	R/W	DESCRIPTION	RESET VALUE
UART3_MCR	0xFFF8_0310	R/W	UART 3 Modem Control Register	0x0000_0000

31	30	29	28	27	26	25	24
Reserved							
23	22	21	20	19	18	17	16
Reserved							
15	14	13	12	11	10	9	8
Reserved							
7	6	5	4	3	2	1	0
Reserved			LBME	Reserved			DTR#



UART3 Modem Status Register (UART3_MSR)

REGISTER	ADDRESS	R/W	DESCRIPTION	RESET VALUE
UART3_MSR	0xFFF8_0318	R	UART 3 Modem Status Register	0x0000_0000

31	30	29	28	27	26	25	24
Reserved							
23	22	21	20	19	18	17	16
Reserved							
15	14	13	12	11	10	9	8
Reserved							
7	6	5	4	3	2	1	0
Reserved	Reserved	DSR#	Reserved	Reserved	Reserved	DDSR	Reserved

6.12.5 General UART Controller

The **Universal Asynchronous Receiver/Transmitter (UART)** performs a serial-to-parallel conversion of data characters received from the peripheral such as MODEM, and a parallel-to-serial conversion of data characters received from the CPU. There are five types of interrupts, i.e., **line status interrupt, transmitter FIFO empty interrupt, receiver threshold level reaching interrupt, time out interrupt, and MODEM status interrupt**. One 16-byte transmitter FIFO (**TX_FIFO**) and one 16-byte (plus 3-bit of error data per byte) receiver FIFO (**RX_FIFO**) has been built in to reduce the number of interrupts presented to the CPU. The CPU can completely read the status of the UART at any time during the operation. The reported status information includes the type and condition of the transfer operations being performed by the UART, as well as any error conditions (parity, overrun, framing, or break interrupt) found. The UART includes a programmable baud rate generator that is capable of dividing crystal clock input by divisors to produce the clock the transmitter and receiver needs. The equation is

$$\text{BaudOut} = \text{crystal clock} / 16 * [\text{Divisor} + 2].$$

UART includes the following features:

- Transmitter and receiver are buffered with a 16-byte FIFO each to reduce the number of interrupts presented to the CPU.
- **Subset of MODEM control functions (DSR, DTR, by IP selection)**
- Fully programmable serial-interface characteristics:
 - 5-, 6-, 7-, or 8-bit characters
 - Even, odd, or no-parity bit generation and detection
 - 1-, 1&1/2, or 2-stop bit generation
 - Baud rate generation
- Line break generation and detection



- False start bit detection
- Full prioritized interrupt system controls
- Loop back mode for internal diagnostic testing

6.12.5.1 UART Control Registers Map

R: read only, W: write only, R/W: both read and write, C: Only value 0 can be written

REGISTER	OFFSET	R/W	DESCRIPTION	RESET VALUE
UART_RBR	0x00	R	Receive Buffer Register (DLAB = 0)	Undefined
UART_THR	0x00	W	Transmit Holding Register (DLAB = 0)	Undefined
UART_IER	0x04	R/W	Interrupt Enable Register (DLAB = 0)	0x0000_0000
UART_DLL	0x00	R/W	Divisor Latch Register (LS) (DLAB = 1)	0x0000_0000
UART_DLM	0x04	R/W	Divisor Latch Register (MS) (DLAB = 1)	0x0000_0000
UART_IIR	0x08	R	Interrupt Identification Register	0x8181_8181
UART_FCR	0x08	W	FIFO Control Register	Undefined
UART_LCR	0x0C	R/W	Line Control Register	0x0000_0000
UART_MCR	0x10	R/W	Modem Control Register (Optional)	0x0000_0000
UART_LSR	0x14	R	Line Status Register	0x6060_6060
UART_MSR	0x18	R	Modem Status Register (Optional)	0x0000_0000
UART_TOR	0x1C	R/W	Time Out Register	0x0000_0000

Note: Real register address = $0xFFF8_0000 + (\text{UART number} - 1) * (0x0100) + \text{offset}$

Note: All of these registers are implemented 8-bit in UART design and is repeated 4 times before sending to the APB bus. For example, when ARM CPU read register UARTn_BRR, ARM CPU obtains UART0_RBR = {RBR[7:0], RBR[7:0], RBR[7:0], RBR[7:0]}.



UART Receive Buffer Register (UART_RBR)

REGISTER	OFFSET	R/W	DESCRIPTION	RESET VALUE
UART_RBR	0x00	R	Receive Buffer Register (DLAB = 0)	Undefined

31	30	29	28	27	26	25	24
Reserved							
23	22	21	20	19	18	17	16
Reserved							
15	14	13	12	11	10	9	8
Reserved							
7	6	5	4	3	2	1	0
8-bit Received Data							

BITS	DESCRIPTIONS	
[7:0]	8-bit Received Data	By reading this register, the UART will return an 8-bit data received from SIN pin (LSB first).

UART Transmit Holding Register (UART_THR)

REGISTER	OFFSET	R/W	DESCRIPTION	RESET VALUE
UART_THR	0x00	W	Transmit Holding Register (DLAB = 0)	Undefined

31	30	29	28	27	26	25	24
Reserved							
23	22	21	20	19	18	17	16
Reserved							
15	14	13	12	11	10	9	8
Reserved							
7	6	5	4	3	2	1	0
8-bit Transmitted Data							

BITS	DESCRIPTIONS	
[7:0]	8-bit Transmitted Data	By writing to this register, the UART will send out 8-bit data through the SOUT pin (LSB first).



UART Interrupt Enable Register (UART_IER)

REGISTER	OFFSET	R/W	DESCRIPTION	RESET VALUE
UART_IER	0x04	R/W	Interrupt Enable Register (DLAB = 0)	0x0000_0000

31	30	29	28	27	26	25	24
Reserved							
23	22	21	20	19	18	17	16
Reserved							
15	14	13	12	11	10	9	8
Reserved							
7	6	5	4	3	2	1	0
RESERVED			nDBGACK_EN	MSIE	RLSIE	THREIE	RDAIE

BITS	DESCRIPTIONS	
[31:5]	Reserved	-
[4]	nDBGACK_EN	ICE debug mode acknowledge enable 0 = When DBGACK is high, the UART receiver time-out clock is held 1 = No matter whether DBGACK is high or not, the UART receiver timer-out clock will not be held
[3]	MSIE	Modem Status Interrupt (Irpt_MOS) Enable 0 = Mask off Irpt_MOS 1 = Enable Irpt_MOS
[2]	RLSIE	Receive Line Status Interrupt (Irpt_RLS) Enable 0 = Mask off Irpt_RLS 1 = Enable Irpt_RLS
[1]	THREIE	Transmit Holding Register Empty Interrupt (Irpt_THRE) Enable 0 = Mask off Irpt_THRE 1 = Enable Irpt_THRE
[0]	RDAIE	Receive Data Available Interrupt (Irpt_RDA) Enable and Time-out Interrupt (Irpt_TOUT) Enable 0 = Mask off Irpt_RDA and Irpt_TOUT 1 = Enable Irpt_RDA and Irpt_TOUT



UART Divider Latch (Low Byte) Register (UART_DLL)

REGISTER	OFFSET	R/W	DESCRIPTION	RESET VALUE
UART_DLL	0x00	R/W	Divisor Latch Register (LS) (DLAB = 1)	0x0000_0000

31	30	29	28	27	26	25	24
Reserved							
23	22	21	20	19	18	17	16
Reserved							
15	14	13	12	11	10	9	8
Reserved							
7	6	5	4	3	2	1	0
Baud Rate Divider (Low Byte)							

BITS	DESCRIPTIONS	
[7:0]	Baud Rate Divider (Low Byte)	The low byte of the baud rate divider

UART Divisor Latch (High Byte) Register (UART_DLM)

REGISTER	OFFSET	R/W	DESCRIPTION	RESET VALUE
UART_DLM	0x04	R/W	Divisor Latch Register (MS) (DLAB = 1)	0x0000_0000

31	30	29	28	27	26	25	24
Reserved							
23	22	21	20	19	18	17	16
Reserved							
15	14	13	12	11	10	9	8
Reserved							
7	6	5	4	3	2	1	0
Baud Rate Divider (High Byte)							

BITS	DESCRIPTIONS	
[7:0]	Baud Rate Divider (High Byte)	The high byte of the baud rate divider

This 16-bit divider {DLM, DLL} is used to determine the baud rate as follows

$$\text{Baud Rate} = \text{Crystal Clock} / \{16 * [\text{Divisor} + 2]\}$$

Note: This definition is different from 16550



UART Interrupt Identification Register (UART_IIR)

REGISTER	OFFSET	R/W	DESCRIPTION	RESET VALUE
UART_IIR	0x08	R	Interrupt Identification Register	0x8181_8181

31	30	29	28	27	26	25	24
Reserved							
23	22	21	20	19	18	17	16
Reserved							
15	14	13	12	11	10	9	8
Reserved							
7	6	5	4	3	2	1	0
FMES	RFTLS		DMS	IID			NIP

BITS	DESCRIPTIONS	
[7]	FMES	FIFO Mode Enable Status This bit indicates whether FIFO mode is enabled or not. Since FIFO mode is always enabled, this bit always shows a logical 1 when the CPU reads this register.
[6:5]	RFTLS	RX FIFO Threshold Level Status These bits show the current setting of receiver FOFO threshold level (RTHO). The meaning of RTHO is defined in the following FCR description.
[4]	DMS	DMA Mode Select DMA function is not implemented in this version. When reading IIR, the DMS always returns 0.
[3:1]	IID	Interrupt Identification The IID together with NIP indicates the current interrupt request from UART
[0]	NIP	No Interrupt Pending There is no pending interrupt.



Table 6.12.5.1 Interrupt Control Functions

IIR [3:0]	PRIORITY	INTERRUPT TYPE	INTERRUPT SOURCE	INTERRUPT RESET CONTROL
---1	--	None	None	--
0110	Highest	Receiver Line Status (Irpt_RLS)	Overrun error, parity error, framing error, or break interrupt	Reading the LSR
0100	Second	Received Data Available (Irpt_RDA)	Receiver FIFO threshold level is reached	Receiver FIFO drops below the threshold level
1100	Second	Receiver FIFO Time-out (Irpt_TOUT)	Receiver FIFO is non-empty and no activity occurred during the TOR defined time duration	Reading the RBR
0010	Third	Transmitter Holding Register Empty (Irpt_THRE)	Transmitter holding register empty	Reading the IIR (if source of interrupt is Irpt_THRE) or writing into the THR
0000	Fourth	MODEM Status (Irpt_MOS)	The CTS, DSR, or DCD bits are changing state or the RI bit is changing from high to low.	Reading the MSR (optional)

Note: These definitions of bit 7, bit 6, bit 5, and bit 4 are different from the 16550

UART FIFO Control Register (UART_FCR)

REGISTER	OFFSET	R/W	DESCRIPTION	RESET VALUE
UART_FCR	0x08	W	FIFO Control Register	Undefined

31	30	29	28	27	26	25	24
Reserved							
23	22	21	20	19	18	17	16
Reserved							
15	14	13	12	11	10	9	8
Reserved							
7	6	5	4	3	2	1	0
RFITL		RESERVED		DMS	TFR	RFR	FME



BITS		DESCRIPTIONS										
[7:6]	RFITL	RX FIFO Interrupt (Irpt_RDA) Trigger Level										
		<table border="1"> <thead> <tr> <th>RFITL [7:6]</th> <th>Irpt_RDA Trigger Level (Bytes)</th> </tr> </thead> <tbody> <tr> <td>00</td> <td>01</td> </tr> <tr> <td>01</td> <td>04</td> </tr> <tr> <td>10</td> <td>08</td> </tr> <tr> <td>11</td> <td>14</td> </tr> </tbody> </table>	RFITL [7:6]	Irpt_RDA Trigger Level (Bytes)	00	01	01	04	10	08	11	14
		RFITL [7:6]	Irpt_RDA Trigger Level (Bytes)									
		00	01									
		01	04									
10	08											
11	14											
[3]	DMS	DMA Mode Select The DMA function is not implemented in this version.										
[2]	TFR	TX FIFO Reset Setting this bit generates an OSC cycle reset pulse to reset TX FIFO. The TX FIFO becomes empty (TX pointer is reset to 0) after such reset. This bit is returned to 0 automatically after the reset pulse is generated.										
[1]	RFR	RX FIFO Reset Setting this bit will generate an OSC cycle reset pulse to reset RX FIFO. The RX FIFO becomes empty (RX pointer is reset to 0) after such reset. This bit is returned to 0 automatically after the reset pulse is generated.										
[0]	FME	FIFO Mode Enable Because UART is always operating in the FIFO mode, writing this bit has no effect while reading always receives a logical 1. This bit must be 1 when other FCR bits are written to; otherwise, they will not be programmed.										

UART Line Control Register (UART_LCR)

REGISTER	OFFSET	R/W	DESCRIPTION	RESET VALUE
UART_LCR	0x0C	R/W	Line Control Register	0x0000_0000

31	30	29	28	27	26	25	24
Reserved							
23	22	21	20	19	18	17	16
Reserved							
15	14	13	12	11	10	9	8
Reserved							
7	6	5	4	3	2	1	0
DLAB	BCB	SPE	EPE	PBE	NSB	WLS	



BITS		DESCRIPTIONS										
[7]	DLAB	Divider Latch Access Bit 0 = It is used to access RBR, THR or IER. 1 = It is used to access Divisor Latch Registers {DLL, DLM}										
[6]	BCB	Break Control Bit When this bit is set to logic 1, the serial data output (SOUT) is forced to the Spacing State (logic 0). This bit acts only on SOUT and has no effect on the transmitter logic.										
[5]	SPE	Stick Parity Enable 0 = Disable stick parity 1 = Parity bit is transmitted and checked as a logic 1 if bit 4 is 0 (odd parity), or as a logic 0 if bit 4 is 1 (even parity). This bit is only effective when bit 3 (parity bit enable) is set.										
[4]	EPE	Even Parity Enable 0 = Odd number of logic 1's are transmitted or checked in the data word and parity bits. 1 = Even number of logic 1's are transmitted or checked in the data word and parity bits. This bit has effect only when bit 3 (parity bit enable) is set.										
[3]	PBE	Parity Bit Enable 0 = Parity bit is not generated (transmit data) or checked (receive data) during transfer. 1 = Parity bit is generated or checked between the "last data word bit" and "stop bit" of the serial data.										
[2]	NSB	Number of "STOP bit" 0= One " STOP bit" is generated in the transmitted data 1= One and a half " STOP bit" is generated in the transmitted data when 5-bit word length is selected; Two " STOP bit" is generated when 6-, 7- and 8-bit word length is selected.										
[1:0]	WLS	Word Length Select <table border="1" style="margin-left: 20px;"> <thead> <tr> <th>WLS[1:0]</th> <th>Character length</th> </tr> </thead> <tbody> <tr> <td>00</td> <td>5 bits</td> </tr> <tr> <td>01</td> <td>6 bits</td> </tr> <tr> <td>10</td> <td>7 bits</td> </tr> <tr> <td>11</td> <td>8 bits</td> </tr> </tbody> </table>	WLS[1:0]	Character length	00	5 bits	01	6 bits	10	7 bits	11	8 bits
WLS[1:0]	Character length											
00	5 bits											
01	6 bits											
10	7 bits											
11	8 bits											

W90P710CD/W90P710CDG



UART Modem Control Register (UART_MCR)

REGISTER	OFFSET	R/W	DESCRIPTION	RESET VALUE
UART_MCR	0x10	R/W	Modem Control Register (Optional)	0x0000_0000

31	30	29	28	27	26	25	24
Reserved							
23	22	21	20	19	18	17	16
Reserved							
15	14	13	12	11	10	9	8
Reserved							
7	6	5	4	3	2	1	0
Reserved			LBME	Reserve	Reserve	Reserved	DTR#

BITS	DESCRIPTIONS	
[31:5]	Reserved	-
[4]	LBME	Loop-back Mode Enable 0 = Disable 1 = When the loop-back mode is enabled, the following signals are connected internally SOUT connected to SIN and SOUT pin fixed at logic 1 DTR# connected to DSR# and DTR# pin fixed at logic 1
[3:1]	Reserved	-
[0]	DTR	Complement version of DTR# (Data-Terminal-Ready) signal Writing 0x00 to MCR, the DTR# bit are set to logic 1's; Writing 0x0f to MCR, the DTR# bit are reset to logic 0's.

UART Line Status Control Register (UART_LSR)

REGISTER	OFFSET	R/W	DESCRIPTION	RESET VALUE
UART_LSR	0x14	R	Line Status Register	0x6060_6060

W90P710CD/W90P710CDG



31	30	29	28	27	26	25	24
Reserved							
23	22	21	20	19	18	17	16
Reserved							
15	14	13	12	11	10	9	8
Reserved							
7	6	5	4	3	2	1	0
ERR_RX	TE	THRE	BII	FEI	PEI	OEI	RFDR

BITS		DESCRIPTIONS
[31:8]	Reserved	-
[7]	ERR_RX	<p>RX FIFO Error</p> <p>0 = RX FIFO works normally</p> <p>1 = There is at least one parity error (PE), framing error (FE), or break indication (BI) in the FIFO. ERR_RX is cleared when CPU reads the LSR and if there are no subsequent errors in the RX FIFO.</p>
[6]	TE	<p>Transmitter Empty</p> <p>0 = Either Transmitter Holding Register (THR - TX FIFO) or Transmitter Shift Register (TSR) are not empty.</p> <p>1 = Both THR and TSR are empty.</p>
[5]	THRE	<p>Transmitter Holding Register Empty</p> <p>0 = THR is not empty.</p> <p>1 = THR is empty.</p> <p>THRE is set when the last data word of TX FIFO is transferred to the Transmitter Shift Register (TSR). The CPU resets this bit when the THR (or TX FIFO) is loaded. This bit also causes the UART to issue an interrupt (Irpt_THRE) to the CPU when IER [1]=1.</p>
[4]	BII	<p>Break Interrupt Indicator</p> <p>This bit is set to a logic 1 whenever the received data input is held in the "spacing state" (logic 0) for longer than a full word transmission time (that is, the total time of "start bit" + data bits + parity + stop bits) and is reset whenever the CPU reads the contents of the LSR.</p>
[3]	FEI	<p>Framing Error Indicator</p> <p>This bit is set to logic 1 whenever the received character does not have a valid "stop bit" (that is, the stop bit following the last data bit or parity bit is detected as a logic 0), and is reset whenever the CPU reads the contents of the LSR.</p>

W90P710CD/W90P710CDG



Continued.

BITS		DESCRIPTIONS
[2]	PEI	Parity Error Indicator This bit is set to logic 1 whenever the received character does not have a valid "parity bit", and is reset whenever the CPU reads the contents of the LSR.
[1]	OEI	Overrun Error Indicator An overrun error will occur only after the RX FIFO is full and the next character has been completely received in the shift register. The character in the shift register is overwritten, but it is not transferred to the RX FIFO. OE is indicated to the CPU as soon as it happens and is reset whenever the CPU reads the contents of the LSR.
[0]	RFDR	RX FIFO Data Ready 0 = RX FIFO is empty 1 = RX FIFO contains at least 1 received data word.

LSR [4:2] (BII, FEI, PEI) are revealed to the CPU when its associated character is at the top of the RX FIFO. These three error indicators are reset whenever the CPU reads the contents of the LSR.

LSR [4:1] (BII, FEI, PEI, OEI) are the error conditions that produce a "receiver line status interrupt" (Irpt_RLS) when IER [2]=1. Reading LSR clears Irpt_RLS. Writing LSR is a null operation (not suggested)

UART Modem Status Register (UART_MSR)

REGISTER	OFFSET	R/W	DESCRIPTION	RESET VALUE
UART_MSR	0x18	R	MODEM Status Register (Optional)	0x0000_0000

31	30	29	28	27	26	25	24
Reserved							
23	22	21	20	19	18	17	16
Reserved							
15	14	13	12	11	10	9	8
Reserved							
7	6	5	4	3	2	1	0
Reserved	Reserved	DSR#	Reserved	Reserved	Reserved	DDSR	Reserved



BITS		DESCRIPTIONS
[31:6]	Reserved	-
[5]	DSR#	Complement version of data set ready (DSR#) input (This bit is selected by IP)
[4:2]	Reserved	-
[1]	DDSR	DSR# State Change (This bit is selected by IP) This bit is set whenever DSR# input has changed state, and it is reset if the CPU reads the MSR.
[0]	Reserved	-

Whenever any of MSR [3:0] is set to logic 1, a Modem Status Interrupt is generated if IER[3]=1. Writing MSR is a null operation (not suggested).

UART Time Out Register (UART_TOR)

REGISTER	OFFSET	R/W	DESCRIPTION	RESET VALUE
UART_TOR	0x1C	R/W	Time Out Register	0x0000_0000

31	30	29	28	27	26	25	24
Reserved							
23	22	21	20	19	18	17	16
Reserved							
15	14	13	12	11	10	9	8
Reserved							
7	6	5	4	3	2	1	0
TOIE	TOIC						

BITS		DESCRIPTIONS
[31:8]	Reserved	-
[7]	TOIE	Time Out Interrupt Enable The feature of receiver time out interrupt is enabled when TOR [7] = IER[0] = 1.
[6:0]	TOIC	Time Out Interrupt Comparator The time out counter resets and starts counting (the counting clock = baud rate) whenever the RX FIFO receives a new data word. Once the content of time out counter (TOUT_CNT) is equal to that of time out interrupt comparator (TOIC), a receiver time out interrupt (Irpt_TOUT) is generated if TOR [7] = IER [0] = 1. A new incoming data word or RX FIFO empty clears Irpt_TOUT.



6.12.6 High speed UART Controller

The **High Speed Universal Asynchronous Receiver/Transmitter (HS_UART)** performs a serial-to-parallel conversion on data characters received from the peripheral, and a parallel-to-serial conversion on data characters received from the CPU. There are five types of interrupt trigger, they are, transmitter FIFO empty, receiver threshold level reaching, line status (overrun error, parity error, framing error or break), timeout, and modem status. One 64-byte transmitter FIFO (**TX_FIFO**) and one 64-byte (plus 3-bit of error data per byte) receiver FIFO (**RX_FIFO**) is built-in to reduce the number of interrupts presented to the CPU. The CPU can completely read the UART status any time during operation. The reported status information includes the type and condition of transfer operations being performed by the UART, as well as any error conditions (parity, overrun, framing, or break) found. The UART includes a programmable baud rate generator capable of dividing crystal clock input to produce the needed clock for the transmitter and receiver. The equation is:

$$\text{Baud Out} = \text{crystal clock} / 16 * [\text{Divisor} + 2].$$

The UART includes the following features:

- Transmitter and receiver are buffered with a 64-byte FIFO each to reduce the number of interrupts presented to the CPU.
- Subset of MODEM control function (selected by IP)
- Fully programmable serial-interface characteristics:
 - 5-, 6-, 7-, or 8-bit character
 - Even, odd, or no-parity bit generation and detection
 - 1-, 1&1/2, or 2-stop bit generation
 - Baud rate generation
- False start bit detection
- Full-prioritized interrupt system control
- Loop back mode not supported

6.12.6.1 High Speed UART Control Registers Map

R: read only, **W:** write only, **R/W:** both read and write, **C:** Only value 0 can be written

REGISTER	OFFSET	R/W	DESCRIPTION	RESET VALUE
HSUART_RBR	0x00	R	Receive Buffer Register (DLAB = 0)	Undefined
HSUART_THR	0x00	W	Transmit Holding Register (DLAB = 0)	Undefined
HSUART_IER	0x04	R/W	Interrupt Enable Register (DLAB = 0)	0x0000_0000
HSUART_DLL	0x00	R/W	Divisor Latch Register (LS)(DLAB = 1)	0x0000_0000
HSUART_DLM	0x04	R/W	Divisor Latch Register (MS)(DLAB = 1)	0x0000_0000



Continued.

REGISTER	OFFSET	R/W	DESCRIPTION	RESET VALUE
HSUART_IIR	0x08	R	Interrupt Identification Register	0x8181_8181
HSUART_FCR	0x08	W	FIFO Control Register	Undefined
HSUART_LCR	0x0C	R/W	Line Control Register	0x0000_0000
HSUART_MCR	0x10	R/W	Modem Control Register (Optional)	0x0000_0000
HSUART_LSR	0x14	R	Line Status Register	0x6060_6060
HSUART_MSR	0x18	R	MODEM Status Register (Optional)	0x0000_0000
HSUART_TOR	0x1C	R/W	Timeout Register	0x0000_0000

Note: Real register address = 0xFFF8_0000+ (UART number – 1) * (0x0100) + offset

NOTE: All of these registers are implemented 8-bit in UART design and is repeated 4 times before send to APB bus. For example, when ARM CPU read register UART1_BRR, ARM CPU will get UART1_RBR = {RBR [7:0], _RBR [7:0], RBR [7:0], RBR [7:0]}.

HSUART Receive Buffer Register (HSUART_RBR)

REGISTER	OFFSET	R/W	DESCRIPTION	RESET VALUE
HSUART_RBR	0x00	R	Receive Buffer Register (DLAB = 0)	Undefined

31	30	29	28	27	26	25	24
Reserved							
23	22	21	20	19	18	17	16
Reserved							
15	14	13	12	11	10	9	8
Reserved							
7	6	5	4	3	2	1	0
8-bit Received Data							

BITS	DESCRIPTIONS	
[7:0]	8-bit Received Data	By reading this register, the UART will return an 8-bit data received from SIN pin (LSB first).



HSUART Transmit Holding Register (HSUART_THR)

REGISTER	OFFSET	R/W	DESCRIPTION	RESET VALUE
HSUART_THR	0x00	W	Transmit Holding Register (DLAB = 0)	Undefined

31	30	29	28	27	26	25	24
Reserved							
23	22	21	20	19	18	17	16
Reserved							
15	14	13	12	11	10	9	8
Reserved							
7	6	5	4	3	2	1	0
8-bit Transmitted Data							

BITS	DESCRIPTIONS	
[7:0]	8-bit Transmitted Data	By writing to this register, the UART will send out 8-bit data through the SOUT pin (LSB first).

HSUART Interrupt Enable Register (HSUART_IER)

REGISTER	OFFSET	R/W	DESCRIPTION	RESET VALUE
HSUART_IER	0x04	R/W	Interrupt Enable Register (DLAB = 0)	0x0000_0000

31	30	29	28	27	26	25	24
Reserved							
23	22	21	20	19	18	17	16
Reserved							
15	14	13	12	11	10	9	8
Reserved							
7	6	5	4	3	2	1	0
RESERVED			nDBGACK_EN	MSIE	RLSIE	THREIE	RDAIE



BITS	DESCRIPTIONS	
[31:5]	Reserved	-
[4]	nDBGACK_EN	ICE debug mode acknowledge enable 0 = When DBGACK is high, the UART receiver timeout clock is held 1 = Whether the DBGACK is high or not, the UART receiver timerout clock is not held
[3]	MSIE	MODEM Status Interrupt (Irpt_MOS) Enable 0 = Mask off Irpt_MOS 1 = Enable Irpt_MOS
[2]	RLSIE	Receive Line Status Interrupt (Irpt_RLS) Enable 0 = Mask off Irpt_RLS 1 = Enable Irpt_RLS
[1]	THREIE	Transmit Holding Register Empty Interrupt (Irpt_THRE) Enable 0 = Mask off Irpt_THRE 1 = Enable Irpt_THRE
[0]	RDAIE	Receive Data Available Interrupt (Irpt_RDA) Enable and Time-out Interrupt (Irpt_TOUT) Enable 0 = Mask off Irpt_RDA and Irpt_TOUT 1 = Enable Irpt_RDA and Irpt_TOUT

HSUART Divider Latch (Low Byte) Register (HSUART_DLL)

REGISTER	OFFSET	R/W	DESCRIPTION	RESET VALUE
HSUART_DLL	0x00	R/W	Divisor Latch Register (LS) (DLAB = 1)	0x0000_0000

31	30	29	28	27	26	25	24
Reserved							
23	22	21	20	19	18	17	16
Reserved							
15	14	13	12	11	10	9	8
Reserved							
7	6	5	4	3	2	1	0
Baud Rate Divider (Low Byte)							



BITS	DESCRIPTIONS	
[31:8]	Reserved	-
[7:0]	Baud Rate Divisor (Low Byte)	The low byte of the baud rate divider

HSUART Divisor Latch (High Byte) Register (HSUART_DLM)

REGISTER	OFFSET	R/W	DESCRIPTION	RESET VALUE
HSUART_DLM	0x04	R/W	Divisor Latch Register (MS) (DLAB = 1)	0x0000_0000

31	30	29	28	27	26	25	24
Reserved							
23	22	21	20	19	18	17	16
Reserved							
15	14	13	12	11	10	9	8
Reserved							
7	6	5	4	3	2	1	0
Baud Rate Divider (High Byte)							

BITS	DESCRIPTIONS	
[31:8]	Reserved	
[7:0]	Baud Rate Divisor (High Byte)	The high byte of the baud rate divider

This 16-bit divider {DLM, DLL} is used to determine the baud rate as follows:

$$\text{Baud Rate} = \text{Crystal Clock} / \{16 * [\text{Divisor} + 2]\}$$

HSUART Interrupt Identification Register (HSUART_IIR)

REGISTER	OFFSET	R/W	DESCRIPTION	RESET VALUE
HSUART_IIR	0x08	R	Interrupt Identification Register	0x8181_8181

W90P710CD/W90P710CDG



31	30	29	28	27	26	25	24
Reserved							
23	22	21	20	19	18	17	16
Reserved							
15	14	13	12	11	10	9	8
Reserved							
7	6	5	4	3	2	1	0
FMES	RFTLS		DMS	IID			NIP

BITS	DESCRIPTIONS	
[31:8]	Reserved	-
[7]	FMES	<p>FIFO Mode Enable Status</p> <p>This bit indicates whether FIFO mode is enabled or not. Since FIFO mode is always enabled, this bit always shows the logical 1 when CPU is reading this register.</p>
[6:5]	RFTLS	<p>RX FIFO Threshold Level Status</p> <p>These bits show the current setting of receiver FIFO threshold level (RTHO). The meaning of RTHO is defined in the following FCR description.</p>
[4]	DMS	<p>DMA Mode Select</p> <p>The DMA function is not implemented in this version. When reading IIR, the DMS always returns 0.</p>
[3:1]	IID	<p>Interrupt Identification</p> <p>The IID together with NIP indicates the current interrupt request from UART.</p>
[0]	NIP	<p>No Interrupt Pending</p> <p>There is no pending interrupt.</p>



Interrupt Control Functions

IIR [3:0]	PRIORITY	INTERRUPT TYPE	INTERRUPT SOURCE	INTERRUPT RESET CONTROL
---1	--	None	None	--
0110	Highest	Receiver Line Status (Irpt_RLS)	Overrun error, parity error, framing error, or break interrupt	Reading the LSR
0100	Second	Received Data Available (Irpt_RDA)	Reach the receiver FIFO threshold	Receiver FIFO drops below the threshold
1100	Second	Receiver FIFO Time-out (Irpt_TOUT)	Receiver FIFO is non-empty and no activities are occurred in the receiver FIFO during the TOR defined time duration	Reading the RBR
0010	Third	Transmitter Holding Register Empty (Irpt_THRE)	Transmitter holding register empty	Reading the IIR (if source of interrupt is Irpt_THRE) or writing into the THR
0000	Fourth	MODEM Status (Irpt_MOS)	The CTS bits are changing state.	Reading the MSR (optional)

Note: These definitions of bit 7, bit 6, bit 5, and bit 4 are different from the 16550.

HSUART FIFO Control Register (HSUART_FCR)

REGISTER	OFFSET	R/W	DESCRIPTION	RESET VALUE
HSUART_FCR	0x08	W	FIFO Control Register	Undefined

31	30	29	28	27	26	25	24
Reserved							
23	22	21	20	19	18	17	16
Reserved							
15	14	13	12	11	10	9	8
Reserved							
7	6	5	4	3	2	1	0
RFITL				DMS	TFR	RFR	FME



BITS	DESCRIPTIONS																			
[31:8]	Reserved	-																		
[7:4]	RFITL	<p>RX FIFO Interrupt (Irpt_RDA) Trigger Level</p> <table border="1" data-bbox="597 548 1365 1020"> <thead> <tr> <th data-bbox="597 548 805 600">RFITL</th> <th data-bbox="805 548 1365 600">Irpt_RDA Trigger Level (Bytes)</th> </tr> </thead> <tbody> <tr> <td data-bbox="597 600 805 653">0000</td> <td data-bbox="805 600 1365 653">01</td> </tr> <tr> <td data-bbox="597 653 805 705">0001</td> <td data-bbox="805 653 1365 705">04</td> </tr> <tr> <td data-bbox="597 705 805 758">0010</td> <td data-bbox="805 705 1365 758">08</td> </tr> <tr> <td data-bbox="597 758 805 810">0011</td> <td data-bbox="805 758 1365 810">14</td> </tr> <tr> <td data-bbox="597 810 805 863">0100</td> <td data-bbox="805 810 1365 863">30</td> </tr> <tr> <td data-bbox="597 863 805 915">0101</td> <td data-bbox="805 863 1365 915">46</td> </tr> <tr> <td data-bbox="597 915 805 968">0110</td> <td data-bbox="805 915 1365 968">62</td> </tr> <tr> <td data-bbox="597 968 805 1020">others</td> <td data-bbox="805 968 1365 1020">62</td> </tr> </tbody> </table>	RFITL	Irpt_RDA Trigger Level (Bytes)	0000	01	0001	04	0010	08	0011	14	0100	30	0101	46	0110	62	others	62
RFITL	Irpt_RDA Trigger Level (Bytes)																			
0000	01																			
0001	04																			
0010	08																			
0011	14																			
0100	30																			
0101	46																			
0110	62																			
others	62																			
[3]	DMS	<p>DMA Mode Select</p> <p>The DMA function is not implemented in this version.</p>																		
[2]	TFR	<p>TX FIFO Reset</p> <p>Setting this bit will generate an OSC cycle reset pulse to reset TX FIFO. The TX FIFO is empty (TX pointer is reset to 0) after resetting. This bit is returned to 0 automatically after the reset pulse is generated.</p>																		
[1]	RFR	<p>RX FIFO Reset</p> <p>Setting this bit will generate an OSC cycle reset pulse to reset RX FIFO. The RX FIFO is empty (RX pointer is reset to 0) after resetting. This bit is returned to 0 automatically after the reset pulse is generated.</p>																		
[0]	FME	<p>FIFO Mode Enable</p> <p>Because UART is always operating in FIFO mode, writing this bit has no effect, while reading always returns a logical 1. This bit must be 1 when other FCR bits are written to; otherwise they are not programmed.</p>																		



HSUART Line Control Register (HSUART_LCR)

REGISTER	OFFSET	R/W	DESCRIPTION	RESET VALUE
HSUART_LCR	0x0C	R/W	Line Control Register	0x0000_0000

BITS	DESCRIPTIONS											
[31:8]	Reserved	-										
[7]	DLAB	Divider Latch Access Bit 0 = It is used to access RBR, THR or IER. 1 = It is used to access Divisor Latch Registers {DLL, DLM}.										
[6]	BCB	Break Control Bit When this bit is set to logic 1, the serial data output (SOUT) is forced to the Spacing State (logic 0). This bit acts only on SOUT and has no effect on the transmitter logic.										
[5]	SPE	Stick Parity Enable 0 = Disable stick parity 1 = Parity bit is transmitted and checked as a logic 1 if bit 4 is 0 (odd parity), or as a logic 0 if bit 4 is 1 (even parity). This bit has effect only when bit 3 (parity bit enable) is set.										
[4]	EPE	Even Parity Enable 0 = Odd number of logic 1's are transmitted or checked in the data word and parity bits. 1 = Even number of logic 1's are transmitted or checked in the data word and parity bits. This bit has effect only when bit 3 (parity bit enable) is set.										
[3]	PBE	Parity Bit Enable 0 = Parity bit is not generated (transmit data) or checked (receive data) during transfer. 1 = Parity bit is generated or checked between the "last data word bit" and "stop bit" of the serial data.										
[2]	NSB	Number of "STOP bit" 0= One "STOP bit" is generated in the transmitted data 1= One and a half "STOP bits" are generated in the transmitted data when 5-bit word length is selected; Two "STOP bits" are generated when 6-, 7- and 8-bit word lengths are selected.										
[1:0]	WLS	Word Length Select <table border="1" data-bbox="721 1556 1214 1787"> <thead> <tr> <th>WLS[1:0]</th> <th>Character length</th> </tr> </thead> <tbody> <tr> <td>00</td> <td>5 bits</td> </tr> <tr> <td>01</td> <td>6 bits</td> </tr> <tr> <td>10</td> <td>7 bits</td> </tr> <tr> <td>11</td> <td>8 bits</td> </tr> </tbody> </table>	WLS[1:0]	Character length	00	5 bits	01	6 bits	10	7 bits	11	8 bits
WLS[1:0]	Character length											
00	5 bits											
01	6 bits											
10	7 bits											
11	8 bits											



31	30	29	28	27	26	25	24
Reserved							
23	22	21	20	19	18	17	16
Reserved							
15	14	13	12	11	10	9	8
Reserved							
7	6	5	4	3	2	1	0
DLAB	BCB	SPE	EPE	PBE	NSB	WLS	

HSUART Modem Control Register (HSUART_MCR)

REGISTER	OFFSET	R/W	DESCRIPTION	RESET VALUE
HSUART_MCR	0x10	R/W	Modem Control Register (Optional)	0x0000_0000

31	30	29	28	27	26	25	24
Reserved							
23	22	21	20	19	18	17	16
Reserved							
15	14	13	12	11	10	9	8
Reserved							
7	6	5	4	3	2	1	0
Reserved			LBME	Reserved		RTS	Reserved

BITS	DESCRIPTIONS	
[31:5]	Reserved	-
[4]	LBME	<p>Loop-back Mode Enable</p> <p>0 = Disable</p> <p>1 = When loop-back mode is enabled, the following signals are connected internally:</p> <p>SOUT connected to SIN and SOUT pin fixed at logic 1</p> <p>RTS# connected to CTS# and RTS# pin fixed at logic 1</p>

W90P710CD/W90P710CDG



Continued.

BITS	DESCRIPTIONS	
[3:2]	Reserved	-
[1]	RTS#	Complement version of RTS# (Request-To-Send) signal Writing 0x00 to MCR, RTS# bit are set to logic 1's; Writing 0x0f to MCR, RTS# bit are reset to logic 0's.
[0]	Reserved	-

HSUART Line Status Control Register (HSUART_LSR)

REGISTER	OFFSET	R/W	DESCRIPTION	RESET VALUE
HSUART_LSR	0x14	R	Line Status Register	0x6060_6060

31	30	29	28	27	26	25	24
Reserved							
23	22	21	20	19	18	17	16
Reserved							
15	14	13	12	11	10	9	8
Reserved							
7	6	5	4	3	2	1	0
ERR_RX	TE	THRE	BII	FEI	PEI	OEI	RFDR

BITS	DESCRIPTIONS	
[31:8]	Reserved	
[7]	ERR_RX	RX FIFO Error 0 = RX FIFO works normally 1 = There is at least one parity error (PE), framing error (FE), or break indication (BI) in the FIFO. ERR_RX is cleared when the CPU reads the LSR and if there are no subsequent errors in the RX FIFO.
[6]	TE	Transmitter Empty 0 = Either Transmitter Holding Register (THR - TX FIFO) or Transmitter Shift Register (TSR) are not empty. 1 = Both THR and TSR are empty.



Continued.

BITS	DESCRIPTIONS	
[5]	THRE	Transmitter Holding Register Empty 0 = THR is not empty. 1 = THR is empty. THRE is set when the last data word of TX FIFO is transferred to Transmitter Shift Register (TSR). The CPU resets this bit when the THR (or TX FIFO) is loaded. This bit also causes the UART to issue an interrupt (Irpt_THRE) to the CPU when IER [1]=1.
[4]	BII	Break Interrupt Indicator This bit is set to logic 1 whenever the received data input is held in the "spacing state" (logic 0) for longer than a full word transmission time (that is, the total time of "start bit" + data bits + parity + stop bits) and is reset whenever the CPU reads the contents of the LSR.
[3]	FEI	Framing Error Indicator This bit is set to logic 1 whenever the received character does not have a valid "stop bit" (that is, the stop bit following the last data bit or parity bit is detected as a logic 0), and is reset whenever the CPU reads the contents of the LSR.
[2]	PEI	Parity Error Indicator This bit is set to logic 1 whenever the received character does not have a valid "parity bit", and is reset whenever the CPU reads the contents of the LSR.
[1]	OEI	Overrun Error Indicator An overrun error occurs only after the RX FIFO is full and the next character has been completely received in the shift register. The character in the shift register is overwritten, but it is not transferred to the RX FIFO. OE is indicated to the CPU as soon as it happens and is reset whenever the CPU reads the contents of the LSR.
[0]	RFDR	RX FIFO Data Ready 0 = RX FIFO is empty 1 = RX FIFO contains at least 1 received data word.

LSR [4:2] (BII, FEI, PEI) are revealed to the CPU when its associated character is at the top of the RX FIFO. These three error indicators are reset whenever the CPU reads the contents of the LSR.

LSR [4:1] (BII, FEI, PEI, OEI) are the error conditions that produce a "receiver line status interrupt" (Irpt_RLS) when IER [2]=1. Reading LSR clears Irpt_RLS. Writing LSR is a null operation (not suggested).

HSUART Modem Status Register (HSUART_MSR)

REGISTER	OFFSET	R/W	DESCRIPTION	RESET VALUE
HSUART_MSR	0x18	R	MODEM Status Register (Optional)	0x0000_0000

31	30	29	28	27	26	25	24
Reserved							
23	22	21	20	19	18	17	16
Reserved							
15	14	13	12	11	10	9	8
Reserved							
7	6	5	4	3	2	1	0
Reserved			CTS#	Reserved			DCTS

BITS	DESCRIPTIONS	
[31:5]	Reserved	-
[4]	CTS#	Complement version of clear to send (CTS#) input (This bit is selected by IP)
[3:1]	Reserved	-
[0]	DCTS	CTS# State Change (This bit is selected by IP) This bit is set whenever CTS# input has changed state, and is reset if the CPU reads the MSR.

Whenever any MSR [0] is set to logic 1, a Modem Status Interrupt is generated if IER[3]=1. Writing to the MSR is a null operation (not recommended).



HSUART Time Out Register (HSUART_TOR)

REGISTER	OFFSET	R/W	DESCRIPTION	RESET VALUE
HSUART_TOR	0x1C	R/W	Time Out Register	0x0000_0000

31	30	29	28	27	26	25	24
Reserved							
23	22	21	20	19	18	17	16
Reserved							
15	14	13	12	11	10	9	8
Reserved							
7	6	5	4	3	2	1	0
TOIE	TOIC						

BITS	DESCRIPTIONS	
[31:8]	Reserved	-
[7]	TOIE	Time Out Interrupt Enable The receiver timeout interrupt is enabled only when TOR [7] = IER[0] = 1.
[6:0]	TOIC	Time Out Interrupt Comparator The time out counter resets and starts counting (the counting clock = baud rate) whenever the RX FIFO receives a new data word. Once the content of the timeout counter (TOUT_CNT) is equal to that of the timeout interrupt comparator (TOIC), a receiver time out interrupt (Irpt_TOUT) is generated if TOR [7] = IER [0] = 1. A new incoming data word or RX FIFO empty clears Irpt_TOUT.



6.13 Timer/Watchdog Controller

6.13.1 General Timer Controller

The timer module includes two channels, TIMER0 and TIMER1, which allows you to easily implement a counting scheme. The timer can perform functions like frequency measurement, event counting, interval measurement, clock generation, delay timing, and so on. The timer possesses features such as adjustable resolution, programmable counting period, and detailed information. The timer can generate an interrupt signal upon timeout, or provide the current value of count during operation.

The general TIMER Controller includes the following features

- AMBA APB interface compatible
- Two channels with an 8-bit prescale counter/24-bit down counter and an interrupt request each
- Independent clock source for each channel
- Maximum uninterrupted time = $(1 / 25 \text{ MHz}) * (256) * (2^{24})$, if TCLK = 25 MHz

6.13.2 Watchdog Timer

6.13.3 Timer Control Registers Map

R: read only, W: write only, R/W: both read and write

REGISTER	ADDRESS	R/W/C	DESCRIPTION	RESET VALUE
TCSR0	0xFFF8_1000	R/W	Timer Control and Status Register 0	0x0000_0005
TCSR1	0xFFF8_1004	R/W	Timer Control and Status Register 1	0x0000_0005
TICR0	0xFFF8_1008	R/W	Timer Initial Control Register 0	0x0000_0000
TICR1	0xFFF8_100C	R/W	Timer Initial Control Register 1	0x0000_0000
TDR0	0xFFF8_1010	R	Timer Data Register 0	0x0000_0000
TDR1	0xFFF8_1014	R	Timer Data Register 1	0x0000_0000
TISR	0xFFF8_1018	R/W	Timer Interrupt Status Register	0x0000_0000
WTCR	0xFFF8_101C	R/W	Watchdog Timer Control Register	0x0000_0400

Timer Control Register 0/1 (TCSR 0/1)

REGISTER	ADDRESS	R/W	DESCRIPTION	RESET VALUE
TCSR0	0xFFF8_1000	R/W	Timer Control and Status Register 0	0x0000_0005
TCSR1	0xFFF8_1004	R/W	Timer Control and Status Register 1	0x0000_0005

W90P710CD/W90P710CDG



31	30	29	28	27	26	25	24
nDBGACK_EN	CEN	IE	MODE[1:0]		CRST	CACT	Reserved
23	22	21	20	19	18	17	16
Reserved							
15	14	13	12	11	10	9	8
Reserved							
7	6	5	4	3	2	1	0
PRESCALE[7:0]							

BITS	DESCRIPTIONS											
[31]	nDBGACK_EN	ICE debug mode acknowledge enable 0 = When DBGACK is high, the TIMER counter is held 1 = Whether DBGACK is high or not, the TIMER counter is not held										
[30]	CEN	Counter Enable 0 = Stops/Suspends counting 1 = Starts counting										
[29]	IE	Interrupt Enable 0 = Disable TIMER Interrupt. 1 = Enable TIMER Interrupt. If the timer interrupt is enabled, the timer asserts its interrupt signal when the associated counter decrements to zero.										
[28:27]	MODE	Timer Operating Mode <table border="1"> <thead> <tr> <th>MODE</th> <th>Timer Operating Mode</th> </tr> </thead> <tbody> <tr> <td>00</td> <td>The timer is operating in one-shot mode. The associated interrupt signal is generated once (if IE is enabled) and CEN is automatically cleared then.</td> </tr> <tr> <td>01</td> <td>The timer is operating in the periodic mode. The associated interrupt signal is generated periodically (if IE is enabled).</td> </tr> <tr> <td>10</td> <td>The timer is operating in the toggle mode. The interrupt signal is generated periodically (if IE is enabled). And the associated signal (tout) is changing back and forth with 50% duty cycle.</td> </tr> <tr> <td>11</td> <td>Reserved.</td> </tr> </tbody> </table>	MODE	Timer Operating Mode	00	The timer is operating in one-shot mode. The associated interrupt signal is generated once (if IE is enabled) and CEN is automatically cleared then.	01	The timer is operating in the periodic mode. The associated interrupt signal is generated periodically (if IE is enabled).	10	The timer is operating in the toggle mode. The interrupt signal is generated periodically (if IE is enabled). And the associated signal (tout) is changing back and forth with 50% duty cycle.	11	Reserved.
MODE	Timer Operating Mode											
00	The timer is operating in one-shot mode. The associated interrupt signal is generated once (if IE is enabled) and CEN is automatically cleared then.											
01	The timer is operating in the periodic mode. The associated interrupt signal is generated periodically (if IE is enabled).											
10	The timer is operating in the toggle mode. The interrupt signal is generated periodically (if IE is enabled). And the associated signal (tout) is changing back and forth with 50% duty cycle.											
11	Reserved.											

W90P710CD/W90P710CDG



Continued

BITS	DESCRIPTIONS	
[26]	CRST	Counter Reset Setting this bit will reset the TIMER counter, and also force CEN to 0. 0 = No effect. 1 = Reset the Timer's prescale counter, internal 24-bit counter and CEN.
[25]	CACT	Timer Status This bit indicates the running status of the timer. 0 = Timer is inactive . 1 = Timer is active .
[24:8]	Reserved	Reserved
[7:0]	PRESCALE	Prescale Clock input is divided by PRESCALE+1 before it is fed to the counter. If PRESCALE=0, then there is no scaling.

Timer Initial Count Register 0/1 (TICR0/1)

REGISTER	ADDRESS	R/W	DESCRIPTION	RESET VALUE
TICR0	0xFFF8_1008	R/W	Timer Initial Control Register 0	0x0000_0000
TICR1	0xFFF8_100C	R/W	Timer Initial Control Register 1	0x0000_0000

31	30	29	28	27	26	25	24
Reserved							
23	22	21	20	19	18	17	16
TIC[23:16]							
15	14	13	12	11	10	9	8
TIC [15:8]							
7	6	5	4	3	2	1	0
TIC[7:0]							

W90P710CD/W90P710CDG



BITS	DESCRIPTIONS	
[31:24]	Reserved	Reserved
[23:0]	TIC	<p>Timer Initial Count</p> <p>This is a 24-bit value representing the initial count. The timer will reload this value whenever the counter is decremented to zero.</p> <p>NOTE1: Never write 0x0 in the TIC, or the core will run into an unknown state.</p> <p>NOTE2: Regardless of whether CEN is 0 or 1, whenever the software writes a new value to this register, the TIMER aborts the previous count and restarts using the new value.</p>

Timer Data Register 0/1 (TDR0/1)

REGISTER	ADDRESS	R/W	DESCRIPTION	RESET VALUE
TDR0	0xFFF8_1010	R	Timer Data Register 0	0x0000_0000
TDR1	0xFFF8_1014	R	Timer Data Register 1	0x0000_0000

31	30	29	28	27	26	25	24
Reserved							
23	22	21	20	19	18	17	16
TDR[23:16]							
15	14	13	12	11	10	9	8
TDR [15:8]							
7	6	5	4	3	2	1	0
TDR[7:0]							

BITS	DESCRIPTIONS	
[31:24]	Reserved	Reserved
[23:0]	TDR	<p>Timer Data Register</p> <p>The current count is registered in this 24-bit value.</p> <p>NOTE: Software can read the current value on this register only when CEN = 0, or the value represented here is not a correct one.</p>



Timer Interrupt Status Register (TISR)

REGISTER	ADDRESS	R/W	DESCRIPTION	RESET VALUE
TISR	0xFFFF8_1018	R/W	Timer Interrupt Status Register	0x0000_0000

31	30	29	28	27	26	25	24
Reserved							
23	22	21	20	19	18	17	16
Reserved							
15	14	13	12	11	10	9	8
Reserved							
7	6	5	4	3	2	1	0
Reserved						TIF1	TIF0

BITS	DESCRIPTIONS	
[1]	TIF1	<p>Timer Interrupt Flag 1</p> <p>This bit indicates the interrupt status of Timer channel 1.</p> <p>0 = Indicates that Timer 1 has not reached zero.</p> <p>1 = Indicates Timer 1 reached zero. If enabled, the interrupt flag is set.</p> <p>NOTE: This bit is read only, but can be cleared by writing 1.</p>
[0]	TIF0	<p>Timer Interrupt Flag 0</p> <p>This bit indicates the interrupt status of Timer channel 0.</p> <p>0 = Indicates that Timer 0 has not reached zero.</p> <p>1 = Indicates Timer 0 reached zero. If enabled, the interrupt flag is set.</p> <p>NOTE: This bit is read only, but can be cleared by writing 0.</p>

Watchdog Timer Control Register (WTCR)

REGISTER	ADDRESS	R/W	DESCRIPTION	RESET VALUE
WTCR	0xFFFF8_101C	R/W	Watchdog Timer Control Register	0x0000_0400

W90P710CD/W90P710CDG



31	30	29	28	27	26	25	24
Reserved							
23	22	21	20	19	18	17	16
Reserved							
15	14	13	12	11	10	9	8
Reserved					WTCLK	nDBGACK_EN	WTTME
7	6	5	4	3	2	1	0
WTE	WTIE	WTIS		WTIF	WTRF	WTRE	WTR

BITS	DESCRIPTIONS	
[31:11]	Reserved	Reserved
[10]	WTCLK	<p>Watchdog Timer</p> <p>Use this bit to divide the Watchdog Timer clock source by 256. The Watchdog Timer clock source is Crystal input.</p> <p>0 = Uses original clock input 1 = Clock input is divided by 256</p> <p>NOTE: When WTTME = 1, setting this bit has no effect on the WDT clock (using original clock input).</p>
[9]	nDBGACK_EN	<p>ICE debug mode acknowledge enable</p> <p>0 = When DBGACK is high, the Watchdog Timer counter is held 1 = Whether DBGACK is high or not, the Watchdog Timer counter is not held</p>
[8]	WTTME	<p>Watchdog Timer Test Mode Enable</p> <p>For reasons of efficiency, the 26-bit counter within the Watchdog Timer is considered as two independent 13-bit counters in test mode. They are operated concurrently and separately during the test. This approach can save a lot of time spent testing. When the 13-bit counter overflows, a Watchdog Timer interrupt is generated.</p> <p>0 = Watchdog Timer operates in normal mode 1 = Watchdog Timer operates in test mode</p>
[7]	WTE	<p>Watchdog Timer Enable</p> <p>0 = Disable the Watchdog Timer (this action will reset the internal counter) 1 = Enable the Watchdog Timer</p>



Continued

BITS	DESCRIPTIONS																						
[6]	WTIE	Watchdog Timer Interrupt Enable 0 = Disable the Watchdog Timer interrupt 1 = Enable the Watchdog Timer interrupt																					
[5:4]	WTIS	Watchdog Timer Interval Select These two bits select the interval for the Watchdog Timer. No matter which interval is chosen, the timeout reset always occurs 512 WDT clock cycles later than the interrupt timeout. <table border="1" data-bbox="591 705 1395 1087"> <thead> <tr> <th data-bbox="591 705 711 781">WTIS</th> <th data-bbox="711 705 891 781">Interrupt Timeout</th> <th data-bbox="891 705 1110 781">Reset Timeout</th> <th data-bbox="1110 705 1395 781">Real Time Interval (CLK=15MHz/256)</th> </tr> </thead> <tbody> <tr> <td data-bbox="591 781 711 856">00</td> <td data-bbox="711 781 891 856">2¹⁴ clocks</td> <td data-bbox="891 781 1110 856">2¹⁴ + 1024 clocks</td> <td data-bbox="1110 781 1395 856">0.28 sec.</td> </tr> <tr> <td data-bbox="591 856 711 932">01</td> <td data-bbox="711 856 891 932">2¹⁶ clocks</td> <td data-bbox="891 856 1110 932">2¹⁶ + 1024 clocks</td> <td data-bbox="1110 856 1395 932">1.12 sec.</td> </tr> <tr> <td data-bbox="591 932 711 1008">10</td> <td data-bbox="711 932 891 1008">2¹⁸ clocks</td> <td data-bbox="891 932 1110 1008">2¹⁸ + 1024 clocks</td> <td data-bbox="1110 932 1395 1008">4.47 sec.</td> </tr> <tr> <td data-bbox="591 1008 711 1087">11</td> <td data-bbox="711 1008 891 1087">2²⁰ clocks</td> <td data-bbox="891 1008 1110 1087">2²⁰ + 1024 clocks</td> <td data-bbox="1110 1008 1395 1087">17.9 sec.</td> </tr> </tbody> </table>		WTIS	Interrupt Timeout	Reset Timeout	Real Time Interval (CLK=15MHz/256)	00	2 ¹⁴ clocks	2 ¹⁴ + 1024 clocks	0.28 sec.	01	2 ¹⁶ clocks	2 ¹⁶ + 1024 clocks	1.12 sec.	10	2 ¹⁸ clocks	2 ¹⁸ + 1024 clocks	4.47 sec.	11	2 ²⁰ clocks	2 ²⁰ + 1024 clocks	17.9 sec.
WTIS	Interrupt Timeout	Reset Timeout	Real Time Interval (CLK=15MHz/256)																				
00	2 ¹⁴ clocks	2 ¹⁴ + 1024 clocks	0.28 sec.																				
01	2 ¹⁶ clocks	2 ¹⁶ + 1024 clocks	1.12 sec.																				
10	2 ¹⁸ clocks	2 ¹⁸ + 1024 clocks	4.47 sec.																				
11	2 ²⁰ clocks	2 ²⁰ + 1024 clocks	17.9 sec.																				
[3]	WTIF	Watchdog Timer Interrupt Flag If the Watchdog Timer interrupt is enabled, then the hardware sets this bit to indicate that a Watchdog Timer interrupt occurred. If the Watchdog Timer interrupt is not enabled, this bit indicates that a timeout period has elapsed. 0 = Watchdog Timer interrupt did not occur 1 = Watchdog Timer interrupt occurred NOTE: This bit is read only, but can be cleared by writing 1.																					
[2]	WTRF	Watchdog Timer Reset Flag When the Watchdog Timer initiates a reset, the hardware will set this bit. This flag can be read by software to determine the source of the reset. This flag is not self-clearing, and must be cleared by the programmer. If WTRE is disabled, then the Watchdog Timer has no effect on this bit. 0 = Watchdog Timer reset does not occur 1 = Watchdog Timer reset occurs NOTE: This bit is read only, but can be cleared by writing 1.																					

W90P710CD/W90P710CDG



Continued

BITS	DESCRIPTIONS	
[1]	WTRE	Watchdog Timer Reset Enable Setting this bit will enable the Watchdog Timer reset function. 0 = Disable Watchdog Timer reset function 1 = Enable Watchdog Timer reset function
[0]	WTR	Watchdog Timer Reset This bit brings the Watchdog Timer into a known state. It helps reset the Watchdog Timer before timeout. Failing to set WTR before timeout initiates an interrupt if WTIE is set. If the WTRE bit is set, the Watchdog Timer reset occurs 512 WDT clock cycles after timeout. This bit is self-clearing. 0 = No operation 1 = Reset the contents of the Watchdog Timer



6.14 Advanced Interrupt Controller

An *interrupt* temporarily changes the sequence of program execution to react to a particular event such as power failure, watchdog timer timeout, transmit/receive requests from the Ethernet MAC Controller, and so on. The ARM7TDMI processor provides two modes of interrupt, the **Fast Interrupt (FIQ)** mode for critical sessions and the *Interrupt (IRQ)* mode for general purpose. An IRQ exception occurs when the nIRQ input is asserted. Similarly, an FIQ exception occurs when the nFIQ input is asserted. The FIQ has privilege over the IRQ and can preempt an ongoing IRQ. It is possible to ignore the FIQ and the IRQ by setting the F and I bits in the **current program status register (CPSR)**.

W90P710 incorporates an **advanced interrupt controller (AIC)** capable of dealing with interrupt requests from a total of 32 different sources. Currently, 31 interrupt sources are defined. Each interrupt source is uniquely assigned an *interrupt channel*. For example, the watchdog timer interrupt is assigned to channel 1. The AIC implements a proprietary eight-level priority scheme that differentiates the available 31 interrupt sources into eight priority levels. Interrupt sources within priority level 0 have the highest priority and the priority level 7 has the lowest. To work this scheme properly, you must specify a certain priority level to each interrupt source during power-on initialization; otherwise, the system shall behave unexpectedly. Within each priority level, interrupt source that is positioned in a lower channel has a higher priority. Interrupt source that is active, enabled, and positioned in the lowest channel within the priority level 0 is promoted to the FIQ. Interrupt sources within the priority levels other than 0 can petition for the IRQ. The IRQ can be preempted by the occurrence of the FIQ. Interrupt nesting is performed automatically by the AIC.

Though interrupt sources originating from the W90P710 itself are intrinsically high-level sensitive, the AIC can be configured as either low-level sensitive, high-level sensitive, negative-edge triggered, or positive-edge triggered to each interrupt source. When the W90P710 is put in test mode, all interrupt sources must be configured as positive-edge triggered.

The advanced interrupt controller includes the following features:

- AMBA APB bus interface
- External interrupts can be programmed as either edge-triggered or level-sensitive
- External interrupts can be programmed as either low-active or high-active
- Has flags to reflect the status of each interrupt source
- Individual mask for each interrupt source
- Proprietary 8-level interrupt scheme to ease the burden from the interrupt
- Priority methodology is adopted to allow for interrupt daisy-chaining
- Automatically masking out lower priority interrupts during interrupt nesting
- Automatically clears the interrupt flag when an external interrupt source is programmed to be edge-triggered



6.14.1 Interrupt Sources

Table 6.14.1 W90P710 Interrupt Sources

PRIORITY	NAME	MODE	SOURCE
1 (Highest)	WDT_INT	Positive Level	Watch Dog Timer Interrupt
2	nIRQ0	Programmable	External Interrupt 0
3	nIRQ1	Programmable	External Interrupt 1
4	nIRQ2	Programmable	External Interrupt 2
5	nIRQ3	Programmable	External Interrupt 3
6	AC97_INT	Positive Level	AC97 Interrupt
7	LCD_INT	Positive Level	LCD Controller Interrupt
8	RTC_INT	Positive Level	RTC Interrupt
9	UART_INT0	Positive Level	UART Interrupt0
10	UART_INT1	Positive Level	UART Interrupt1
11	UART_INT2	Positive Level	UART Interrupt2
12	UART_INT3	Positive Level	UART Interrupt3
13	T_INT0	Positive Level	Timer Interrupt 0
14	T_INT1	Positive Level	Timer Interrupt 1
15	USBH_INT0	Positive Level	USB Host Interrupt 0
16	USBH_INT1	Positive Level	USB Host Interrupt 1
17	EMCTX_INT	Positive Level	EMC TX Interrupt
18	EMCRX_INT	Positive Level	EMC RX Interrupt
19	GDMA_INT0	Positive Level	GDMA Channel Interrupt 0
20	GDMA_INT1	Positive Level	GDMA Channel Interrupt 1
21	SD_INT	Positive Level	SD Interrupt
22	USB_D_INT	Positive Level	USB Device Interrupt
23	SC_INT0	Positive Level	Smart Card Interrupt 0
24	SC_INT1	Positive Level	Smart Card Interrupt 1
25	I2C_INT0	Positive Level	I2C Interrupt0
26	I2C_INT1	Positive Level	I2C Interrupt1
27	SSP_INT	Positive Level	SSP Interrupt
28	PWM_INT	Positive Level	PWM Timer interrupt
29	KPI_INT	Positive Level	Keypad Interrupt
30	PS2_INT	Positive Level	PS2 Interrupt
31	IRQ45_INT	Positive Level	GPIO0 & GPIO70 Interrupt



AIC Functional Description

Hardware Interrupt Vectoring

Hardware interrupt vectoring can be used to shorten the interrupt latency. If not used, priority determination must be carried out by software. When the Interrupt Priority Encoding Register (AIC_IPER) is read, it will return an integer representing the channel that is active and having the highest priority. This integer is equivalent to multiplication by 4 (shifted left two bits to word-align it) such that it may be used directly to index into a branch table to select the appropriate interrupt service routine vector.

Priority Controller

An 8-level priority encoder controls the NIRQ line. Each interrupt source belongs to a priority group between 0 and 7. Group 0 has the highest priority and group 7, the lowest. When more than one unmasked interrupt channels are active at a time, the interrupt with the highest priority is serviced first. If all active interrupts have equal priority, the interrupt with the lowest interrupt source number is serviced first.

The current priority level is defined as the priority level of the interrupt with the highest priority at the time the register AIC_IPER is read. In the event that a higher priority unmasked interrupt occurs while an interrupt already exists, there are two possible outcomes depending on whether the AIC_IPER has been read.

If the processor has already read the AIC_IPER and caused the NIRQ line to be deasserted, then the NIRQ line is reasserted. When the processor has enabled nested interrupts and reads the AIC_IPER again, it reads the new, higher priority interrupt vector. At the same time, the current priority level is updated to a higher priority.

If the AIC_IPER has not been read after the NIRQ line has been asserted, then the processor will read the new higher priority interrupt vector in the AIC_IPER register and the current priority level is updated.

When the End of Service Command Register (AIC_EOSCR) is written, the current interrupt level is updated with the last stored interrupt level from the stack (if any). Therefore, at the end of a higher priority interrupt, the AIC returns to the previous state corresponding to the preceding lower priority interrupt which was interrupted.

Interrupt Handling

When the IRQ line is asserted, the interrupt handler must read the AIC_IPER as soon as possible. This can deassert the NIRQ request to the processor and clears the interrupt if it is programmed to be edge triggered. This allows the AIC to assert the NIRQ line again when a higher priority unmasked interrupt occurs.

The AIC_EOSCR (End of Service Command Register) must be written at the end of the interrupt service routine. This permits pending interrupts to be serviced.



Interrupt Masking

Each interrupt source, including FIQ, can be enabled or disabled individually by using command registers AIC_MECR and AIC_MDCR. The status of the interrupt mask can be read in the read only register AIC_IMR. A disabled interrupt doesn't affect the servicing of other interrupts.

Interrupt Clearing and Setting

All interrupt sources (including FIQ) can be individually set or clear by respectively writing to the registers AIC_SSCR and AIC_SCCR when they are programmed to be edge triggered. This feature of the AIC is useful in auto-testing or software debugging.

Fake Interrupt

When the AIC asserts the NIRQ line, the processor enters interrupt mode and the interrupt handler reads the AIC_IPER, it may happen that AIC deasserts the NIRQ line after the processor has taken into account the NIRQ assertion and before the read of the AIC_IPER.

This behavior is called a fake interrupt.

The AIC is able to detect these fake interrupts and returns all zero when AIC_IPER is read. The same mechanism of fake interrupt occurs if the processor reads the AIC_IPER (application software or ICE) when there is no interrupt pending. The current priority level is not updated in this situation. Hence, the AIC_EOSCR shouldn't be written.

ICE/Debug Mode

This mode allows reading of the AIC_IPER without performing the associated automatic operations. This is necessary when working with a debug system. When an ICE or debug monitor reads the AIC user interface, the AIC_IPER can be read. This has the following consequences in normal mode:

- If there is no enabled pending interrupt, the fake vector is returned.
- If an enabled interrupt with a higher priority than the current one is pending, it is stacked.

In the second case, an End-of-Service command is necessary to restore the state of the AIC. This operation is generally not performed by the debug system. Therefore, the debug system would become strongly intrusive, and may cause the application to enter an undesired state.

This can be avoided by using ICE/Debug Mode. When this mode is enabled. The AIC performs interrupt stacking only when write access is performed on the AIC_IPER. Hence, the interrupt service routine must write to the AIC_IPER (any value) just after reading it. When AIC_IPER is written, the new status of AIC, including the value of interrupt source number register (AIC_ISNR), is updated with the value that is kept at the previous AIC_IPER. The debug system must not write to the AIC_IPER as this would cause undesirable effects.

The following table shows the main steps of an interrupt and the order in which they are performed according to the mode:



ACTION	NORMAL MODE	ICE/DEBUG MODE
Calculate active interrupt	Read AIC_IPER	Read AIC_IPER
Determine and return the vector of the active interrupt	Read AIC_IPER	Read AIC_IPER
Push on internal stack the current priority level	Read AIC_IPER	Write AIC_IPER
Acknowledge the interrupt (Note 1)	Read AIC_IPER	Write AIC_IPER
No effect (Note 2)	Read AIC_IPER	

Notes:

- NIRQ deassertion and automatic interrupt clearing if the source is programmed as level sensitive.
- Note that software which has been written and debugged using this mode will run correctly in normal mode without modification. However, in normal mode writing to AIC_IPER has no effect and can be removed to optimize the code

6.14.2 AIC Registers Map

REGISTER	ADDRESS	R/W	DESCRIPTION	RESET VALUE
AIC_SCR1	0xFFF8_2004	R/W	Source Control Register 1	0x0000_0047
AIC_SCR2	0xFFF8_2008	R/W	Source Control Register 2	0x0000_0047
AIC_SCR3	0xFFF8_200C	R/W	Source Control Register 3	0x0000_0047
AIC_SCR4	0xFFF8_2010	R/W	Source Control Register 4	0x0000_0047
AIC_SCR5	0xFFF8_2014	R/W	Source Control Register 5	0x0000_0047
AIC_SCR6	0xFFF8_2018	R/W	Source Control Register 6	0x0000_0047
AIC_SCR7	0xFFF8_201C	R/W	Source Control Register 7	0x0000_0047
AIC_SCR8	0xFFF8_2020	R/W	Source Control Register 8	0x0000_0047
AIC_SCR9	0xFFF8_2024	R/W	Source Control Register 9	0x0000_0047
AIC_SCR10	0xFFF8_2028	R/W	Source Control Register 10	0x0000_0047
AIC_SCR11	0xFFF8_202C	R/W	Source Control Register 11	0x0000_0047
AIC_SCR12	0xFFF8_2030	R/W	Source Control Register 12	0x0000_0047
AIC_SCR13	0xFFF8_2034	R/W	Source Control Register 13	0x0000_0047
AIC_SCR14	0xFFF8_2038	R/W	Source Control Register 14	0x0000_0047
AIC_SCR15	0xFFF8_203C	R/W	Source Control Register 15	0x0000_0047

W90P710CD/W90P710CDG



AIC Registers Map, continued

REGISTER	ADDRESS	R/W	DESCRIPTION	RESET VALUE
AIC_SCR16	0xFFF8_2040	R/W	Source Control Register 16	0x0000_0047
AIC_SCR17	0xFFF8_2044	R/W	Source Control Register 17	0x0000_0047
AIC_SCR18	0xFFF8_2048	R/W	Source Control Register 18	0x0000_0047
AIC_SCR19	0xFFF8_204C	R/W	Source Control Register 19	0x0000_0047
AIC_SCR20	0xFFF8_2050	R/W	Source Control Register 20	0x0000_0047
AIC_SCR21	0xFFF8_2054	R/W	Source Control Register 21	0x0000_0047
AIC_SCR22	0xFFF8_2058	R/W	Source Control Register 22	0x0000_0047
AIC_SCR23	0xFFF8_205C	R/W	Source Control Register 23	0x0000_0047
AIC_SCR24	0xFFF8_2060	R/W	Source Control Register 24	0x0000_0047
AIC_SCR25	0xFFF8_2064	R/W	Source Control Register 25	0x0000_0047
AIC_SCR26	0xFFF8_2068	R/W	Source Control Register 26	0x0000_0047
AIC_SCR27	0xFFF8_206C	R/W	Source Control Register 27	0x0000_0047
AIC_SCR28	0xFFF8_2070	R/W	Source Control Register 28	0x0000_0047
AIC_SCR29	0xFFF8_2074	R/W	Source Control Register 29	0x0000_0047
AIC_SCR30	0xFFF8_2078	R/W	Source Control Register 30	0x0000_0047
AIC_SCR31	0xFFF8_207C	R/W	Source Control Register 31	0x0000_0047
AIC_IRSR	0xFFF8_2100	R	Interrupt Raw Status Register	0x0000_0000
AIC_IASR	0xFFF8_2104	R	Interrupt Active Status Register	0x0000_0000
AIC_ISR	0xFFF8_2108	R	Interrupt Status Register	0x0000_0000
AIC_IPER	0xFFF8_210C	R	Interrupt Priority Encoding Register	0x0000_0000
AIC_ISNR	0xFFF8_2110	R	Interrupt Source Number Register	0x0000_0000
AIC_IMR	0xFFF8_2114	R	Interrupt Mask Register	0x0000_0000
AIC_OISR	0xFFF8_2118	R	Output Interrupt Status Register	0x0000_0000
AIC_MECR	0xFFF8_2120	W	Mask Enable Command Register	Undefined
AIC_MDCR	0xFFF8_2124	W	Mask Disable Command Register	Undefined
AIC_SSCR	0xFFF8_2128	W	Source Set Command Register	Undefined
AIC_SCCR	0xFFF8_212C	W	Source Clear Command Register	Undefined
AIC_EOSCR	0xFFF8_2130	W	End of Service Command Register	Undefined
AIC_TEST	0xFFF8_2200	W	ICE/Debug mode Register	Undefined



AIC Source Control Registers (AIC_SCR1 ~ AIC_SCR31)

REGISTER	ADDRESS	R/W	DESCRIPTION	RESET VALUE
AIC_SCR1	0xFFF8_2004	R/W	Source Control Register 1	0x0000_0047
AIC_SCR2	0xFFF8_2008	R/W	Source Control Register 2	0x0000_0047
...
AIC_SCR28	0xFFF8_2070	R/W	Source Control Register 28	0x0000_0047
AIC_SCR29	0xFFF8_2074	R/W	Source Control Register 29	0x0000_0047
AIC_SCR30	0xFFF8_2078	R/W	Source Control Register 30	0x0000_0047
AIC_SCR31	0xFFF8_207C	R/W	Source Control Register 31	0x0000_0047

31	30	29	28	27	26	25	24	
RESERVED								
23	22	21	20	19	18	17	16	
RESERVED								
15	14	13	12	11	10	9	8	
RESERVED								
7	6	5	4	3	2	1	0	
SRCTYPE		RESERVED				PRIORITY		

BITS	DESCRIPTIONS											
[31:8]	Reserved	Reserved										
[7:6]	SRCTYPE	<p>Interrupt Source Type</p> <p>Whether an interrupt source is considered active or not by the AIC is subject to the settings of this field. Interrupt sources other than nIRQ0, nIRQ1, nIRQ2, nIRQ3, should be configured as level sensitive during normal operation unless being tested.</p> <table border="1"> <thead> <tr> <th>SRCTYPE [7:6]</th> <th>Interrupt Source Type</th> </tr> </thead> <tbody> <tr> <td>0 0</td> <td>Low-level Sensitive</td> </tr> <tr> <td>0 1</td> <td>High-level Sensitive</td> </tr> <tr> <td>1 0</td> <td>Negative-edge Triggered</td> </tr> <tr> <td>1 1</td> <td>Positive-edge Triggered</td> </tr> </tbody> </table>	SRCTYPE [7:6]	Interrupt Source Type	0 0	Low-level Sensitive	0 1	High-level Sensitive	1 0	Negative-edge Triggered	1 1	Positive-edge Triggered
SRCTYPE [7:6]	Interrupt Source Type											
0 0	Low-level Sensitive											
0 1	High-level Sensitive											
1 0	Negative-edge Triggered											
1 1	Positive-edge Triggered											



Continued

BITS	DESCRIPTIONS	
[5:3]	Reserved	Reserved
[2:0]	PRIORITY	<p>Priority Level</p> <p>Every interrupt source must be assigned a priority level during initiation. Among them, priority level 0 has the highest priority and priority level 7 the lowest. Interrupt sources with priority level 0 are promoted to FIQ. Interrupt sources with priority level other than 0 belong to IRQ. The interrupt sources of the same priority level located in the lower channel number has higher priority.</p>

AIC Interrupt Raw Status Register (AIC_IRSR)

REGISTER	ADDRESS	R/W	DESCRIPTION	RESET VALUE
AIC_IRSR	0xFFF8_2100	R	Interrupt Raw Status Register	0x0000_0000

31	30	29	28	27	26	25	24
IRS31	IRS30	IRS29	IRS28	IRS27	IRS26	IRS25	IRS24
23	22	21	20	19	18	17	16
IRS23	IRS22	IRS21	IRS20	IRS19	IRS18	IRS17	IRS16
15	14	13	12	11	10	9	8
IRS15	IRS14	IRS13	IRS12	IRS11	IRS10	IRS9	IRS8
7	6	5	4	3	2	1	0
IRS7	IRS6	IRS5	IRS4	IRS3	IRS2	IRS1	RESERVED

BITS	DESCRIPTIONS	
[31:1]	IRSx	<p>This register records the intrinsic state within each interrupt channel.</p> <p>IRSx: Interrupt Status</p> <p>Indicate the intrinsic status of the corresponding interrupt source</p> <p>0 = Interrupt channel is at voltage level 0</p> <p>1 = Interrupt channel is at voltage level 1</p>
[0]	Reserved	Reserved



AIC Interrupt Active Status Register (AIC_IASR)

REGISTER	ADDRESS	R/W	DESCRIPTION	RESET VALUE
AIC_IASR	0xFFF8_2104	R	Interrupt Active Status Register	0x0000_0000

31	30	29	28	27	26	25	24
IAS31	IAS30	IAS29	IAS28	IAS27	IAS26	IAS25	IAS24
23	22	21	20	19	18	17	16
IAS23	IAS22	IAS21	IAS20	IAS19	IAS18	IAS17	IAS16
15	14	13	12	11	10	9	8
IAS15	IAS14	IAS13	IAS12	IAS11	IAS10	IAS9	IAS8
7	6	5	4	3	2	1	0
IAS7	IAS6	IAS5	IAS4	IAS3	IAS2	IAS1	RESERVED

BITS	DESCRIPTIONS	
[31:1]	IASx	<p>This register indicates the status of each interrupt channel in consideration of the interrupt source type as defined in the corresponding Source Control Register, regardless of its mask setting.</p> <p>IASx: Interrupt Active Status</p> <p>Indicates the status of the corresponding interrupt source</p> <p>0 = Corresponding interrupt channel is inactive</p> <p>1 = Corresponding interrupt channel is active</p>
[0]	Reserved	Reserved

AIC Interrupt Status Register (AIC_ISR)

REGISTER	ADDRESS	R/W	DESCRIPTION	RESET VALUE
AIC_ISR	0xFFF8_2108	R	Interrupt Status Register	0x0000_0000

W90P710CD/W90P710CDG



31	30	29	28	27	26	25	24
IS31	IS30	IS29	IS28	IS27	IS26	IS25	IS24
23	22	21	20	19	18	17	16
IS23	IS22	IS21	IS20	IS19	IS18	IS17	IS16
15	14	13	12	11	10	9	8
IS15	IS14	IS13	IS12	IS11	IS10	IS9	IS8
7	6	5	4	3	2	1	0
IS7	IS6	IS5	IS4	IS3	IS2	IS1	RESERVED

BITS		DESCRIPTIONS
[31:1]	ISx	<p>This register identifies those interrupt channels that are both active and enabled.</p> <p>ISx: Interrupt Status Indicates the status of corresponding interrupt channel 0 = Two possibilities: (1) The corresponding interrupt channel is inactive no matter whether it is enabled or disabled; (2) It is active but not enabled 1 = Corresponding interrupt channel is both active and enabled (can assert an interrupt)</p>
[0]	Reserved	Reserved

AIC IRQ Priority Encoding Register (AIC_IPER)

REGISTER	ADDRESS	R/W	DESCRIPTION	RESET VALUE
AIC_IPER	0xFFF8_210C	R	Interrupt Priority Encoding Register	0x0000_0000

31	30	29	28	27	26	25	24
0	0	0	0	0	0	0	0
23	22	21	20	19	18	17	16
0	0	0	0	0	0	0	0
15	14	13	12	11	10	9	8
0	0	0	0	0	0	0	0
7	6	5	4	3	2	1	0
0	VECTOR					0	0



BITS	DESCRIPTIONS	
[6:2]	Vector	<p>When the AIC generates an interrupt, VECTOR represents the interrupt channel number that is active, enabled, and has the highest priority. If the representing interrupt channel possesses a priority level 0, then the interrupt asserted is FIQ; otherwise, it is IRQ. The value of VECTOR is copied to the register AIC_ISNR thereafter by the AIC. This register is restored to 0 after being read by the interrupt handler. This register can help indexing into a branch table to quickly jump to the corresponding interrupt service routine.</p> <p>VECTOR [6:2]: Interrupt Vector 0 = no interrupt occurs 1 ~ 31 = representing the interrupt channel that is active, enabled, and having the highest priority</p>
[0]	Reserved	Reserved

AIC Interrupt Source Number Register (AIC_ISNR)

REGISTER	ADDRESS	R/W	DESCRIPTION	RESET VALUE
AIC_ISNR	0xFFF8_2110	R	Interrupt Source Number Register	0x0000_0000

31	30	29	28	27	26	25	24
0	0	0	0	0	0	0	0
23	22	21	20	19	18	17	16
0	0	0	0	0	0	0	0
15	14	13	12	11	10	9	8
0	0	0	0	0	0	0	0
7	6	5	4	3	2	1	0
0	0	0	IRQID				

BITS	DESCRIPTIONS	
[31:5]	Reserved	Reserved
[4:0]	IRQID	<p>The purpose of this register is to record the interrupt channel number that is active, enabled, and with the highest priority.</p> <p>IRQID [4:0]: IRQ Identification Stands for the interrupt channel number</p>



AIC Interrupt Mask Register (AIC_IMR)

REGISTER	ADDRESS	R/W	DESCRIPTION	RESET VALUE
AIC_IMR	0xFFF8_2114	R	Interrupt Mask Register	0x0000_0000

31	30	29	28	27	26	25	24
IM31	IM30	IM29	IM28	IM27	IM26	IM25	IM24
23	22	21	20	19	18	17	16
IM23	IM22	IM21	IM20	IM19	IM18	IM17	IM16
15	14	13	12	11	10	9	8
IM15	IM14	IM13	IM12	IM11	IM10	IM9	IM8
7	6	5	4	3	2	1	0
IM7	IM6	IM5	IM4	IM3	IM2	IM1	RESERVED

BITS	DESCRIPTIONS	
[31:1]	IM x	<p>IMx: Interrupt Mask</p> <p>This bit determines whether the corresponding interrupt channel is enabled or disabled. Every interrupt channel can be active no matter whether it is enabled or disabled. If an interrupt channel is enabled, it does not definitely mean it is active. Every interrupt channel can be authorized by the AIC only when it is both active and enabled.</p> <p>0 = Corresponding interrupt channel is disabled 1 = Corresponding interrupt channel is enabled</p>
[0]	Reserved	Reserved

AIC Output Interrupt Status Register (AIC_OISR)

REGISTER	ADDRESS	R/W	DESCRIPTION	RESET VALUE
AIC_OISR	0xFFF8_2118	R	Output Interrupt Status Register	0x0000_0000

31	30	29	28	27	26	25	24
RESERVED							
23	22	21	20	19	18	17	16
RESERVED							
15	14	13	12	11	10	9	8
RESERVED							
7	6	5	4	3	2	1	0
RESERVED						IRQ	FIQ

The AIC classifies the interrupt into FIQ and IRQ. This register indicates whether the asserted interrupt is FIQ or IRQ. If both IRQ and FIQ are equal to 0, it means that no interrupt occurred.



BITS	DESCRIPTIONS	
[31:2]	Reserved	Reserved
[1]	IRQ	IRQ [1]: Interrupt Request 0 = nIRQ line is inactive. 1 = nIRQ line is active.
[0]	FIQ	FIQ [0]: Fast Interrupt Request 0 = nFIQ line is inactive. 1 = nFIQ line is active

AIC Mask Enable Command Register (AIC_MECR)

REGISTER	ADDRESS	R/W	DESCRIPTION	RESET VALUE
AIC_MECR	0xFFF8_2120	W	Mask Enable Command Register	Undefined

31	30	29	28	27	26	25	24
MEC31	MEC30	MEC29	MEC28	MEC27	MEC26	MEC25	MEC24
23	22	21	20	19	18	17	16
MEC23	MEC22	MEC21	MEC20	MEC19	MEC18	MEC17	MEC16
15	14	13	12	11	10	9	8
MEC15	MEC14	MEC13	MEC12	MEC11	MEC10	MEC9	MEC8
7	6	5	4	3	2	1	0
MEC7	MEC6	MEC5	MEC4	MEC3	MEC2	MEC1	RESERVED

BITS	DESCRIPTIONS	
[31:1]	MECx	MECx: Mask Enable Command 0 = No effect 1 = Enables the corresponding interrupt channel
[0]	Reserved	Reserved



AIC Mask Disable Command Register (AIC_MDCR)

REGISTER	ADDRESS	R/W	DESCRIPTION	RESET VALUE
AIC_MDCR	0xFFF8_2124	W	Mask Disable Command Register	Undefined

31	30	29	28	27	26	25	24
MDC31	MDC30	MDC29	MDC28	MDC27	MDC26	MDC25	MDC24
23	22	21	20	19	18	17	16
MDC23	MDC22	MDC21	MDC20	MDC19	MDC18	MDC17	MDC16
15	14	13	12	11	10	9	8
MDC15	MDC14	MDC13	MDC12	MDC11	MDC10	MDC9	MDC8
7	6	5	4	3	2	1	0
MDC7	MDC6	MDC5	MDC4	MDC3	MDC2	MDC1	RESERVED

BITS	DESCRIPTIONS	
[31:1]	MDCx	MDCx: Mask Disable Command 0 = No effect 1 = Disables the corresponding interrupt channel
[0]	Reserved	Reserved

AIC Source Set Command Register (AIC_SSCR)

REGISTER	ADDRESS	R/W	DESCRIPTION	RESET VALUE
AIC_SSCR	0xFFF8_2128	W	Source Set Command Register	Undefined

31	30	29	28	27	26	25	24
SSC31	SSC30	SSC29	SSC28	SSC27	SSC26	SSC25	SSC24
23	22	21	20	19	18	17	16
SSC23	SSC22	SSC21	SSC20	SSC19	SSC18	SSC17	SSC16
15	14	13	12	11	10	9	8
SSC15	SSC14	SSC13	SSC12	SSC11	SSC10	SSC9	SSC8
7	6	5	4	3	2	1	0
SSC7	SSC6	SSC5	SSC4	SSC3	SSC2	SSC1	RESERVED

W90P710CD/W90P710CDG



BITS	DESCRIPTIONS	
[31:1]	SSCx	When the W90P710 is under <u>debugging</u> or <u>verification</u> , software can activate any interrupt channel by setting the corresponding bit in this register. This feature is useful for hardware <u>verification</u> or software debugging. SSCx: Source Set Command 0 = No effect. 1 = Activates the corresponding interrupt channel
[0]	Reserved	Reserved

AIC Source Clear Command Register (AIC_SCCR)

REGISTER	ADDRESS	R/W	DESCRIPTION	RESET VALUE
AIC_SCCR	0xFFF8_212C	W	Source Clear Command Register	Undefined

31	30	29	28	27	26	25	24
SCC31	SCC30	SCC29	SCC28	SCC27	SCC26	SCC25	SCC24
23	22	21	20	19	18	17	16
SCC23	SCC22	SCC21	SCC20	SCC19	SCC18	SCC17	SCC16
15	14	13	12	11	10	9	8
SCC15	SCC14	SCC13	SCC12	SCC11	SCC10	SCC9	SCC8
7	6	5	4	3	2	1	0
SCC7	SCC6	SCC5	SCC4	SCC3	SCC2	SCC1	RESERVED

BITS	DESCRIPTIONS	
[31:1]	SCCx	When the W90P710 is under <u>debugging</u> or <u>verification</u> , software can deactivate any interrupt channel by setting the corresponding bit in this register. This feature is useful in hardware <u>verification</u> or software debugging. SCCx: Source Clear Command 0 = No effect. 1 = Deactivates the corresponding interrupt channels
[0]	Reserved	Reserved

AIC End of Service Command Register (AIC_EOSCR)

REGISTER	ADDRESS	R/W	DESCRIPTION	RESET VALUE
AIC_EOSCR	0xFFF8_2130	W	End of Service Command Register	Undefined

W90P710CD/W90P710CDG



31	30	29	28	27	26	25	24
---	---	---	---	---	---	---	---
23	22	21	20	19	18	17	16
---	---	---	---	---	---	---	---
15	14	13	12	11	10	9	8
---	---	---	---	---	---	---	---
7	6	5	4	3	2	1	0
---	---	---	---	---	---	---	---

BITS	DESCRIPTIONS	
[31:0]	EOSCR	This register is used by the interrupt service routine to indicate that it is completely served. Thus, the interrupt handler can write any value to this register to indicate the end of its interrupt service.

AIC ICE/Debug Register (AIC_TEST)

REGISTER	ADDRESS	R/W	DESCRIPTION	RESET VALUE
AIC_TEST	0xFFF8_2200	W	ICE/Debug mode Register	Undefined

31	30	29	28	27	26	25	24
RESERVED							
23	22	21	20	19	18	17	16
RESERVED							
15	14	13	12	11	10	9	8
RESERVED							
7	6	5	4	3	2	1	0
RESERVED							TEST

BITS	DESCRIPTIONS	
[31:1]	Reserved	Reserved
[0]	TEST	<p>This register indicates if AIC_IPER was cleared after being read. If bit0 of AIC_TEST has been set, ICE or the debug monitor can read AIC_IPER for verification and the AIC_IPER is not automatically cleared. Write access to the AIC_IPER will perform interrupt stacking in this mode.</p> <p>TEST: ICE/Debug mode</p> <p>0 = Normal mode. 1 = ICE/Debug mode.</p>



6.15 General-Purpose Input/Output

The General-Purpose Input/Output (**GPIO**) module possesses 71 pins and serves multiple functions. Each port can be configured by software to meet various system configurations and design requirements. Software must configure each pin before starting the main program. If a pin is not used for multiplexed functions, the pin can be configured as an I/O port

Two extended interrupts nIRQ4 (GPIO0 pin) and nIRQ5 (nWAIT pin) use the same AIC interrupt request (channel #31). It can be programmed as low/high sensitive or positive/negative edge triggered. When interrupt #31 is asserted in AIC, the software can poll **XISTATUS** status register to identify which interrupt occurs.

These 71 IO pins are divided into 7 groups according to its peripheral interface definition.

- Port0: 5-pin input/output port
- Port1: 10-pin input/output port
- Port2: 10-pin input/output port
- Port3: 8-pin input/output port
- Port4: 11-pin input/output port
- Port5: 15-pin input/output port
- Port6: 12-pin input/output port

Table 6.15.1 GPIO multiplexed functions table

PORT0	Configurable Pin Functions			
0	GPIO0	AC97_nRESET (I2S_MCLK)	nIRQ4	USBPWREN
1	GPIO1	AC97_DATAI (I2S_DATAI)	PWM0	DTR3
2	GPIO2	AC97_DATAO (I2S_DATAO)	PWM1	DSR3
3	GPIO3	AC97_SYNC (I2S_LRCLK)	PWM2	TXD3
4	GPIO4	AC97_BITCLK (I2S_BITCLK)	PWM3	RXD3
PORT1	Configuration Pin Functions			
0	GPIO20	SC1_PWR	nXDACK	VD8
1	GPIO21	SC1_PRES	nXDREQ	VD9
2	GPIO22	SC1_RST	SD_CD	VD10
3	GPIO23	SC1_CLK	-	VD11
4	GPIO24	SC1_DAT	SD_DAT3	VD12
5	GPIO25	SC0_PWR	SD_DAT2	VD13

W90P710CD/W90P710CDG



Table 6.15.1 GPIO multiplexed functions table, continued

6	GPIO26	SC0_PRES	SD_DAT1	VD14
7	GPIO27	SC0_RST	SD_DAT0	VD15
8	GPIO28	SC0_CLK	SD_CLK	VD16
9	GPIO29	SC0_DAT	SD_CMD	VD17
PORT2	Configuration Pin Functions			
0	GPIO42	PHY_RXERR	KPCOL0	VD8
1	GPIO43	PHY_CRSDV	KPCOL1	VD9
2	GPIO44	PHY_RXD[0]	KPCOL2	VD10
3	GPIO45	PHY_RXD[1]	KPCOL3	VD11
4	GPIO46	PHY_REFCLK	KPCOL4	VD12
5	GPIO47	PHY_TXEN	KPCOL5	VD13
6	GPIO48	PHY_TXD[0]	KPCOL6	VD14
7	GPIO49	PHY_TXD[1]	KPCOL7	VD15
8	GPIO50	PHY_MDIO	KPROW0	VD16
9	GPIO51	PHY_MDC	KPROW1	VD17
PORT3	Configuration Pin Functions			
0	GPIO60	D24	VD16	-
1	GPIO61	D25	VD17	-
2	GPIO62	D26	VD18	-
3	GPIO63	D27	VD19	-
4	GPIO64	D28	VD20	-
5	GPIO65	D29	VD21	-
6	GPIO66	D30	VD22	-
7	GPIO67	D31	VD23	-
PORT4	Configuration Pin Functions			
0	GPIO52	D16	VD8	-
1	GPIO53	D17	VD9	-
2	GPIO54	D18	VD10	-
3	GPIO55	D19	VD11	-
4	GPIO56	D20	VD12	-
5	GPIO57	D21	VD13	-
6	GPIO58	D22	VD14	-

W90P710CD/W90P710CDG



Table 6.15.1 GPIO multiplexed functions table, continued

7	GPIO59	D23	VD15	-
8	GPIO68	nWBE2/SDQM2	-	-
9	GPIO69	nWBE3/SDQM3	-	-
10	GPIO70	nWAIT	nIRQ5	-
PORT5	Configuration Pin Functions			
0	GPIO5	TXD0	-	-
1	GPIO6	RXD0	-	-
2	GPIO7	TXD1	-	-
3	GPIO8	RXD1	-	-
4	GPIO9	TXD2	CTS1	PS2CLK
5	GPIO10	RXD2	RTS1	PS2DATA
6	GPIO11	SCL0	SFRM	TIMER0
7	GPIO12	SDA0	SSPTXD	TIMER1
8	GPIO13	SCL1	SCLK	KPROW3
9	GPIO14	SDA1	SSPRXD	KPROW2
10	GPIO15	nWDOG	USBPWREN	-
11	GPIO16	nIRQ0	-	-
12	GPIO17	nIRQ1	USBOVRCUR	-
13	GPIO18	nIRQ2	-	-
14	GPIO19	nIRQ3	-	-
PORT6	Configuration Pin Function			
0	GPIO30	VCLK	KPROW0	-
1	GPIO31	VDEN	KPROW1	-
2	GPIO32	VSYNC	KPROW2	-
3	GPIO33	HSYNC	KPROW3	-
4	GPIO34	VD0	KPCOL0	-
5	GPIO35	VD1	KPCOL1	-
6	GPIO36	VD2	KPCOL2	-
7	GPIO37	VD3	KPCOL3	-
8	GPIO38	VD4	KPCOL4	-
9	GPIO39	VD5	KPCOL5	-
10	GPIO40	VD6	KPCOL6	-
11	GPIO41	VD7	KPCOL7	-



6.15.1 GPIO Control Registers Map

REGISTER	ADDRESS	R/W	DESCRIPTION	RESET VALUE
GPIO_CFG0	0xFFF8_3000	R/W	GPIO port0 configuration register	0x0000_0000
GPIO_DIR0	0xFFF8_3004	R/W	GPIO port0 direction control register	0x0000_0000
GPIO_DATAOUT0	0xFFF8_3008	R/W	GPIO port0 data output register	0x0000_0000
GPIO_DATAIN0	0xFFF8_300C	R	GPIO port0 data input register	0XXXXX_XXXX
GPIO_CFG1	0xFFF8_3010	R/W	GPIO port1 configuration register	0x0000_0000
GPIO_DIR1	0xFFF8_3014	R/W	GPIO port1 direction control register	0x0000_0000
GPIO_DATAOUT1	0xFFF8_3018	R/W	GPIO port1 data output register	0x0000_0000
GPIO_DATAIN1	0xFFF8_301C	R	GPIO port1 data input register	0XXXXX_XXXX
GPIO_CFG2	0xFFF8_3020	R/W	GPIO port2 configuration register	0x0000_0000
GPIO_DIR2	0xFFF8_3024	R/W	GPIO port2 direction control register	0x0000_0000
GPIO_DATAOUT2	0xFFF8_3028	R/W	GPIO port2 data output register	0x0000_0000
GPIO_DATAIN2	0xFFF8_302C	R	GPIO port2 data input register	0x0000_0000
GPIO_CFG3	0xFFF8_3030	R/W	GPIO port3 configuration register	0x0000_5555
GPIO_DIR3	0xFFF8_3034	R/W	GPIO port3 direction control register	0x0000_0000
GPIO_DATAOUT3	0xFFF8_3038	R/W	GPIO port3 data output register	0x0000_0000
GPIO_DATAIN3	0xFFF8_303C	R	GPIO port3 data input register	0XXXXX_XXXX
GPIO_CFG4	0xFFF8_3040	R/W	GPIO port4 configuration register	0x0015_5555
GPIO_DIR4	0xFFF8_3044	R/W	GPIO port4 direction control register	0x0000_0000
GPIO_DATAOUT4	0xFFF8_3048	R/W	GPIO port4 data output register	0x0000_0000
GPIO_DATAIN4	0xFFF8_304C	R	GPIO port4 data input register	0XXXXX_XXXX

W90P710CD/W90P710CDG



GPIO Control Registers Map, continued

REGISTER	ADDRESS	R/W	DESCRIPTION	RESET VALUE
GPIO_CFG5	0xFFF8_3050	R/W	GPIO port5 configuration register	0x0000_0000
GPIO_DIR5	0xFFF8_3054	R/W	GPIO port5 direction control register	0x0000_0000
GPIO_DATAOUT5	0xFFF8_3058	R/W	GPIO port5 data output register	0x0000_0000
GPIO_DATAIN5	0xFFF8_305C	R	GPIO port5 data input register	0XXXXX_XXXX
GPIO_CFG6	0xFFF8_3060	R/W	GPIO port6 configuration register	0x0000_0000
GPIO_DIR6	0xFFF8_3064	R/W	GPIO port6 direction control register	0x0000_0000
GPIO_DATAOUT6	0xFFF8_3068	R/W	GPIO port6 data output register	0x0000_0000
GPIO_DATAIN6	0xFFF8_306C	R	GPIO port6 data input register	0XXXXX_XXXX
GPIO_DBNCECON	0xFFF8_3070	R/W	GPIO input debounce control register	0x0000_0000
GPIO_XICFG	0xFFF8_3074	R/W	Extend Interrupt Configure Register	0XXXXX_XXX0
GPIO_XISTATUS	0xFFF8_3078	R/W	Extend Interrupt Status Register	0XXXXX_XXX0

6.15.2 GPIO Register Description

GPIO Port0 Configuration Register (GPIO_CFG0)

REGISTER	ADDRESS	R/W	DESCRIPTION	RESET VALUE
GPIO_CFG0	0xFFF8_3000	R/W	GPIO port0 configuration register	0x0000_0000

31	30	29	28	27	26	25	24
RESERVED							
23	22	21	20	19	18	17	16
RESERVED							
15	14	13	12	11	10	9	8
RESERVED						PT0CFG4	
7	6	5	4	3	2	1	0
PT0CFG3		PT0CFG2		PT0CFG1		PT0CFG0	

W90P710CD/W90P710CDG



PT0CFG0	11		10		01		00	
	Name	Type	Name	Type	Name	Type	Name	Type
PORT00	USB_PWREN	O	nIRQ4		AC97RESET or I2SMCLK	O	GPIO0	I/O

PT0CFG1	11		10		01		00	
	Name	Type	Name	Type	Name	Type	Name	Type
PORT0_1	DTR3	O	PWM0	O	AC97DATAI or I2SDATAI	O	GPIO1	I/O

PT0CFG2	11		10		01		00	
	Name	Type	Name	Type	Name	Type	Name	Type
PORT0_2	DSR3	I	PWM1	O	AC97DATAO or I2SDATAO	O	GPIO2	I/O

PT0CFG3	11		10		01		00	
	Name	Type	Name	Type	Name	Type	Name	Type
PORT0_3	TXD3	O	PWM2	O	AC97SYNC or I2SLRCLK	O	GPIO3	I/O

PT0CFG4	11		10		01		00	
	Name	Type	Name	Type	Name	Type	Name	Type
PORT0_4	RXD3	I	PWM3	O	AC97BITCLK or I2SBITCLK	I O	GPIO4	I/O

GPIO Port0 Direction Register (GPIO_DIR0)

REGISTER	ADDRESS	R/W	DESCRIPTION	RESET VALUE
GPIO_DIR0	0xFFF8_3004	R/W	GPIO port0 in/out direction control and pull-up enable register	0x0000_0000

W90P710CD/W90P710CDG



31	30	29	28	27	26	25	24
RESERVED							
23	22	21	20	19	18	17	16
RESERVED				PUPEN0[3:0]			
15	14	13	12	11	10	9	8
RESERVED							
7	6	5	4	3	2	1	0
RESERVED				OMDEN0[4:0]			

Bits	Description	
[31:20]	RESERVED	-
[19:16]	PUPEN0	<p>GPIO3 -GPIO0 port pin internal pull-up resister enable</p> <p>There are 4 bits for this register, setting a bit to 1 enables a pull-up resister on an I/O pin.</p> <p>1 = Enable pull-up resister 0 = Disable pull-up resister</p> <p>After power on, the pull-up resisters are disabled.</p> <p>NOTE: GPIO4 is used as AC97 BITCLK input, an I/O pad with Schmitt trigger input buffer PDB04SDGZ is implemented for this pin. Due to TSMC I/O library without a pull-up resister, an external pull-up resister is necessary.</p>
[15:5]	RESERVED	
[4:0]	OMDEN0	<p>GPIO4 ~GPIO0 output mode enable</p> <p>1 = Enable GPIOx output mode 0 = GPIOx is input mode</p> <p>NOTE: Output mode enable bits are valid only when bit PT0CFG4-0 is configured for general purpose I/O.</p> <p>Each port pin can be enabled individually by setting the corresponding control bit.</p>

GPIO Port0 Data Output Register (GPIO_DATAOUT0)

REGISTER	ADDRESS	R/W	DESCRIPTION	RESET VALUE
GPIO_DATAOUT0	0xFFF8_3008	R/W	GPIO port0 data output register	0x0000_0000

W90P710CD/W90P710CDG



31	30	29	28	27	26	25	24
RESERVED							
23	22	21	20	19	18	17	16
RESERVED							
15	14	13	12	11	10	9	8
RESERVED							
7	6	5	4	3	2	1	0
RESERVED				DATAOUT0			

BITS	DESCRIPTION	
[31:5]	RESERVED	-
[4:0]	DATAOUT0	PORT0 data output value Writing data to this register reflects the data value on the corresponding pin when it is configured as a general output pin. And writing data to reserved bits is not effective.

GPIO Port0 Data Input Register (GPIO_DATAIN0)

REGISTER	ADDRESS	R/W	DESCRIPTION	RESET VALUE
GPIO_DATAIN0	0xFFFF8_300C	R/W	GPIO port0 data input register	0xFFFFX_XXXX

31	30	29	28	27	26	25	24
RESERVED							
23	22	21	20	19	18	17	16
RESERVED							
15	14	13	12	11	10	9	8
RESERVED							
7	6	5	4	3	2	1	0
RESERVED				DATAIN0			

BITS	DESCRIPTION	
[31:5]	RESERVED	-
[4:0]	DATAIN0	PORT0 data input value The DATAIN0 indicates the status of each GPIO0~GPIO4 port pin regardless of its operation mode. The reserved bits are read as 0.



GPIO Port1 Configuration Register (GPIO_CFG1)

REGISTER	ADDRESS	R/W	DESCRIPTION	RESET VALUE
GPIO_CFG1	0xFFFF8_3010	R/W	GPIO port1 configuration register	0x0000_0000

31	30	29	28	27	26	25	24
RESERVED							
23	22	21	20	19	18	17	16
RESERVED				PT1CFG9		PT1CFG8	
15	14	13	12	11	10	9	8
PT1CFG7		PT1CFG6		PT1CFG5		PT1CFG4	
7	6	5	4	3	2	1	0
PT1CFG3		PT1CFG2		PT1CFG1		PT1CFG0	

*In the following pin definition, the shaded functions are default.

PT1CFG0	11		10		01		00	
	Name	Type	Name	Type	Name	Type	Name	Type
PORT1_0	VD8		SC1_PWR	O	nXDACK	O	GPIO20	I/O

PT1CFG1	11		10		01		00	
	Name	Type	Name	Type	Name	Type	Name	Type
PORT1_1	VD9		SC1_PRES	I	nXDREQ	I	GPIO21	I/O

PT1CFG2	11		10		01		00	
	Name	Type	Name	Type	Name	Type	Name	Type
PORT1_2	VD10		SC1_RST	O	SD_CD	I	GPIO22	I/O

PT1CFG3	11		10		01		00	
	Name	Type	Name	Type	Name	Type	Name	Type
PORT1_3	VD11		SC1_CLK	O	RESERVED		GPIO23	I/O

PT1CFG4	11		10		01		00	
	Name	Type	Name	Type	Name	Type	Name	Type
PORT1_4	VD12		SC1_DAT	O	SD_DAT3	I/O	GPIO24	I/O

W90P710CD/W90P710CDG



PT1CFG5	11		10		01		00	
	Name	Type	Name	Type	Name	Type	Name	Type
PORT1_5	VD13		SC0_PWR	O	SD_DAT2	I/O	GPIO25	I/O

PT1CFG6	11		10		01		00	
	Name	Type	Name	Type	Name	Type	Name	Type
PORT1_6	VD14		SC0_PRES	O	SD_DAT1	I/O	GPIO26	I/O

PT1CFG7	11		10		01		00	
	Name	Type	Name	Type	Name	Type	Name	Type
PORT1_7	VD15		SC0_RST	O	SD_DAT0	I/O	GPIO27	I/O

PT1CFG8	11		10		01		00	
	Name	Type	Name	Type	Name	Type	Name	Type
PORT1_8	VD16		SC0_CLK	O	SD_CLK	O	GPIO28	I/O

PT1CFG9	11		10		01		00	
	Name	Type	Name	Type	Name	Type	Name	Type
PORT1_9	VD17		SC0_DAT	O	SD_CMD	I/O	GPIO29	I/O

GPIO Port1 Direction Register (GPIO_DIR1)

REGISTER	ADDRESS	R/W	DESCRIPTION	RESET VALUE
GPIO_DIR1	0xFFF8_3014	R/W	GPIO port0 in/out direction control and pull-up enable register	0x0000_0000

31	30	29	28	27	26	25	24
RESERVED						PUPEN1[9:8]	
23	22	21	20	19	18	17	16
PUPEN1[7:0]							
15	14	13	12	11	10	9	8
RESERVED						OMDEN1[9:8]	
7	6	5	4	3	2	1	0
OMDEN1[7:0]							

W90P710CD/W90P710CDG



BITS	DESCRIPTION	
[31:26]	RESERVED	-
[25:16]	PUPEN1	GPIO51 ~ GPIO42 port pins internal pull-up resistor enable This is a 10-bit register. Setting a bit to 1 enables the corresponding pull up resistor I/O pin. 1 = Enable pull-up resistor 0 = Disable pull-up resistor After power on, the resistors are disabled.
[15:10]	RESERVED	-
[9:0]	OMDEN1	GPIO51 ~ GPIO42 output mode enable 1 = Enable GPIOx output mode 0 = GPIOx is input mode NOTE: Output mode enable bits are valid only when bit PT1CFG9-0 is configured as general purpose I/O mode. Each port pin can be enabled individually by setting the corresponding control bit.

GPIO Port1 Data Output Register (GPIO_DATAOUT1)

REGISTER	ADDRESS	R/W	DESCRIPTION	RESET VALUE
GPIO_DATAOUT1	0xFFF8_3018	R/W	GPIO port1 data output register	0x0000_0000

31	30	29	28	27	26	25	24
RESERVED							
23	22	21	20	19	18	17	16
RESERVED							
15	14	13	12	11	10	9	8
RESERVED						DATAOUT1[9:8]	
7	6	5	4	3	2	1	0
DATAOUT1[7:0]							

BITS	DESCRIPTION	
[31:10]	RESERVED	-
[9:0]	DATAOUT1	PORT1 data output value Writing data to this register reflects the data value on the corresponding port1 pin when it is configured as a general-purpose output pin. And writing data to reserved bits is not effective.



GPIO Port1 Data Input Register (GPIO_DATAIN1)

REGISTER	ADDRESS	R/W	DESCRIPTION	RESET VALUE
GPIO_DATAIN1	0xFFFF8_301C	R/W	GPIO port1 data input register	0xXXXXX_XXXX

31	30	29	28	27	26	25	24
RESERVED							
23	22	21	20	19	18	17	16
RESERVED							
15	14	13	12	11	10	9	8
RESERVED						DATAIN1[9:8]	
7	6	5	4	3	2	1	0
DATAIN1[7:0]							

BITS	DESCRIPTION	
[31:10]	RESERVED	-
[9:0]	DATAIN1	Port1 input data register DATAIN1 indicates the status of each GPIO29~GPIO20 pin regardless of its operating mode. The reserved bits are read as 0s.

GPIO Port2 Configuration Register (GPIO_CFG2)

REGISTER	ADDRESS	R/W	DESCRIPTION	RESET VALUE
GPIO_CFG2	0xFFFF8_3020	R/W	GPIO port2 configuration register	0x0000_0000

31	30	29	28	27	26	25	24
RESERVED							
23	22	21	20	19	18	17	16
RESERVED				PT2CFG9		PT2CFG8	
15	14	13	12	11	10	9	8
PT2CFG7		PT2CFG6		PT2CFG5		PT2CFG4	
7	6	5	4	3	2	1	0
PT2CFG3		PT2CFG2		PT2CFG1		PT2CFG0	

W90P710CD/W90P710CDG



*In the following pin definition, shaded functions are set by default.

PT2CFG0	11		10		01		00	
	Name	Type	Name	Type	Name	Type	Name	Type
PORT2_0	VD8	O	KPCOL0	I	PHY_RXERR	I	GPIO42	I/O

PT2CFG1	11		10		01		00	
	Name	Type	Name	Type	Name	Type	Name	Type
PORT2_1	VD9	O	KPCOL1	I	PHY_CRSDV	I	GPIO43	I/O

PT2CFG2	11		10		01		00	
	Name	Type	Name	Type	Name	Type	Name	Type
PORT2_2	VD10	O	KPCOL2	I	PHY_RXD[0]	I	GPIO44	I/O

PT2CFG3	11		10		01		00	
	Name	Type	Name	Type	Name	Type	Name	Type
PORT2_3	VD11	O	KPCOL3	I	PHY_RXD[1]	I	GPIO45	I/O

PT2CFG4	11		10		01		00	
	Name	Type	Name	Type	Name	Type	Name	Type
PORT2_4	VD12	O	KPCOL4	I	PHY_REFCLK	I	GPIO46	I/O

PT2CFG5	11		10		01		00	
	Name	Type	Name	Type	Name	Type	Name	Type
PORT2_5	VD13	O	KPCOL5	I	PHY_TXEN	O	GPIO47	I/O

PT2CFG6	11		10		01		00	
	Name	Type	Name	Type	Name	Type	Name	Type
PORT2_6	VD14	O	KPCOL6	I	PHY_TXD[0]	O	GPIO48	I/O

PT2CFG7	11		10		01		00	
	Name	Type	Name	Type	Name	Type	Name	Type
PORT2_7	VD15	O	KPCOL7	I	PHY_TXD[1]	O	GPIO49	I/O

PT2CFG8	11		10		01		00	
	Name	Type	Name	Type	Name	Type	Name	Type
PORT2_8	VD16	O	KPROW0	O	PHY_MDIO	I/O	GPIO50	I/O

W90P710CD/W90P710CDG



PT2CFG9	11		10		01		00	
	Name	Type	Name	Type	Name	Type	Name	Type
PORT2_9	VD17	O	KPROW1	O	PHY_MDC	O	GPIO51	I/O

GPIO Port2 Direction Register (GPIO_DIR2)

REGISTER	ADDRESS	R/W	DESCRIPTION	RESET VALUE
GPIO_DIR2	0xFFF8_3024	R/W	GPIO port2 in/out direction control and pull-up enable register	0x0000_0000

31	30	29	28	27	26	25	24
RESERVED						PUPEN2[9:8]	
23	22	21	20	19	18	17	16
PUPEN2[7:0]							
15	14	13	12	11	10	9	8
RESERVED						OMDEN2[9:8]	
7	6	5	4	3	2	1	0
OMDEN2[7:0]							

BITS	DESCRIPTION	
[31:26]	RESERVED	-
[25:16]	PUPEN2	GPIO51 ~ GPIO42 port pin internal pull-up resistor enable This is a 10-bit register; setting a bit to 1 enables the corresponding pull-up resistor I/O pin. 1 = Enable pull-up resistor 0 = Disable pull-up resistor After power on, the registers are disabled.
[15:10]	RESERVED	
[9:0]	OMDEN2	GPIO51 ~ GPIO42 output mode enable 1 = Enable GPIOx output mode 0 = GPIOx is input mode NOTE: Output mode enable bits are valid only when bit PT2CFG7-0 is configured as a general purpose I/O mode. Each port pin can be enabled individually by setting the corresponding control bit.

W90P710CD/W90P710CDG



PGPIO Port2 Data Output Register (GPIO_DATAOUT2)

REGISTER	ADDRESS	R/W	DESCRIPTION	RESET VALUE
GPIO_DATAOUT2	0xFFF8_3028	R/W	GPIO port2 data output register	0x0000_0000

31	30	29	28	27	26	25	24
RESERVED							
23	22	21	20	19	18	17	16
RESERVED							
15	14	13	12	11	10	9	8
RESERVED						DATAOUT2[9:8]	
7	6	5	4	3	2	1	0
DATAOUT2[7:0]							

BITS	DESCRIPTION	
[31:10]	RESERVED	-
[9:0]	DATAOUT2	<p>PORT2 data output value</p> <p>Writing data to this register reflects the data value on the corresponding port2 pin when it is configured as a general-purpose output pin. And writing data to reserved bits is not effective.</p>

GPIO Port2 Data Input Register (GPIO_DATAIN2)

REGISTER	ADDRESS	R/W	DESCRIPTION	RESET VALUE
GPIO_DATAIN2	0xFFF8_302C	R/W	GPIO port2 data input register	0xFFFF_XXXX

31	30	29	28	27	26	25	24
RESERVED							
23	22	21	20	19	18	17	16
RESERVED							
15	14	13	12	11	10	9	8
RESERVED						DATAIN2[9:8]	
7	6	5	4	3	2	1	0
DATAIN2[7:0]							

W90P710CD/W90P710CDG



BITS	DESCRIPTION	
[31:10]	RESERVED	-
[9:0]	DATAIN2	Port2 input data register DATAIN2 indicates the status of each GPIO42~GPIO51 pin regardless of its operating mode. The reserved bits are read as 0s.

GPIO Port3 Configuration Register (GPIO_CFG3)

REGISTER	ADDRESS	R/W	DESCRIPTION	RESET VALUE
GPIO_CFG3	0xFFF8_3030	R/W	GPIO port3 configuration register	0x0000_5555

31	30	29	28	27	26	25	24
RESERVED							
23	22	21	20	19	18	17	16
RESERVED							
15	14	13	12	11	10	9	8
PT3CFG7		PT3CFG6		PT3CFG5		PT3CFG4	
7	6	5	4	3	2	1	0
PT3CFG3		PT3CFG2		PT3CFG1		PT3CFG0	

*In the following pin definition, the shaded functions are set by default.

PT3CFG0	11		10		01		00	
	Name	Type	Name	Type	Name	Type	Name	Type
PORT3_0	RESERVED		VD16	O	D24	I/O	GPIO60	I/O

PT3CFG1	11		10		01		00	
	Name	Type	Name	Type	Name	Type	Name	Type
PORT3_1	RESERVED		VD17	O	D25	I/O	GPIO61	I/O

PT3CFG2	11		10		01		00	
	Name	Type	Name	Type	Name	Type	Name	Type
PORT3_2	RESERVED		VD18	O	D26	I/O	GPIO62	I/O

W90P710CD/W90P710CDG



PT3CFG3	11		10		01		00	
	Name	Type	Name	Type	Name	Type	Name	Type
PORT3_3	RESERVED		VD19	O	D27	I/O	GPIO63	I/O

PT3CFG4	11		10		01		00	
	Name	Type	Name	Type	Name	Type	Name	Type
PORT3_4	RESERVED		VD20	O	D28	I/O	GPIO64	I/O

PT3CFG5	11		10		01		00	
	Name	Type	Name	Type	Name	Type	Name	Type
PORT3_5	RESERVED		VD21	O	D29	I/O	GPIO65	I/O

PT3CFG6	11		10		01		00	
	Name	Type	Name	Type	Name	Type	Name	Type
PORT3_6	RESERVED		VD22	O	D30	I/O	GPIO66	I/O

PT3CFG7	11		10		01		00	
	Name	Type	Name	Type	Name	Type	Name	Type
PORT3_7	RESERVED		VD23	O	D31	I/O	GPIO67	I/O

GPIO Port3 Direction Register (GPIO_DIR3)

REGISTER	ADDRESS	R/W	DESCRIPTION	RESET VALUE
GPIO_DIR3	0xFFF8_3034	R/W	GPIO port3 in/out direction control and pull-up enable register	0x0000_0000

31	30	29	28	27	26	25	24
RESERVED							
23	22	21	20	19	18	17	16
PUPEN3[7:0]							
15	14	13	12	11	10	9	8
RESERVED							
7	6	5	4	3	2	1	0
OMDEN3[7:0]							



BITS	DESCRIPTION	
[31:24]	RESERVED	-
[23:16]	PUPEN2	GPIO67 ~ GPIO60 port pin internal pull-up resistor enable 1 = Enable pull-up resistor 0 = Disable pull-up resistor After power on, the pull-up registers are disabled
[15:8]	RESERVED	
[7:0]	OMDEN2	GPIO67 ~ GPIO60 output mode enable 1 = Enable GPIOx output mode 0 = GPIOx is input mode NOTE: Output mode enable bits are valid only when bit PT3CFG7-0 is configured as general purpose I/O mode. Each port pin can be enabled individually by setting the corresponding control bit.

GPIO Port3 Data Output Register (GPIO_DATAOUT3)

REGISTER	ADDRESS	R/W	DESCRIPTION	RESET VALUE
GPIO_DATAOUT3	0xFFF8_3038	R/W	GPIO port3 data output register	0x0000_0000

31	30	29	28	27	26	25	24
RESERVED							
23	22	21	20	19	18	17	16
RESERVED							
15	14	13	12	11	10	9	8
RESERVED							
7	6	5	4	3	2	1	0
DATAOUT3[7:0]							

BITS	DESCRIPTION	
[31:8]	RESERVED	-
[7:0]	DATAOUT3	PORT3 data output value Writing data to this register reflects the data value on the corresponding port3 pin when it is configured as a general-purpose output pin. And writing data to reserved bits is not effective.



GPIO Port3 Data Input Register (GPIO_DATAIN3)

REGISTER	ADDRESS	R/W	DESCRIPTION	RESET VALUE
GPIO_DATAIN3	0xFFF8_303C	R/W	GPIO port3 data input register	0xFFFF_XXXX

31	30	29	28	27	26	25	24
RESERVED							
23	22	21	20	19	18	17	16
RESERVED							
15	14	13	12	11	10	9	8
RESERVED							
7	6	5	4	3	2	1	0
DATAIN3[7:0]							

BITS	DESCRIPTION	
[31:8]	RESERVED	-
[7:0]	DATAIN3	Port3 input data register The DATAIN3 indicates the status of each GPIO67~GPIO60 pin regardless of its operation mode. The reserved bits is read as 0s.

GPIO Port4 Configuration Register (GPIO_CFG4)

REGISTER	ADDRESS	R/W	DESCRIPTION	RESET VALUE
GPIO_CFG4	0xFFF8_3040	R/W	GPIO port4 configuration register	0x0015_5555

31	30	29	28	27	26	25	24
RESERVED							
23	22	21	20	19	18	17	16
RESERVED		PT4CFG10		PT4CFG9		PT4CFG8	
15	14	13	12	11	10	9	8
PT4CFG7		PT4CFG6		PT4CFG5		PT4CFG4	
7	6	5	4	3	2	1	0
PT4CFG3		PT4CFG2		PT4CFG1		PT4CFG0	

W90P710CD/W90P710CDG



*In the following pin definition, the shaded functions are set by default.

PT4CFG0	11		10		01		00	
	Name	Type	Name	Type	Name	Type	Name	Type
PORT4_0	RESERVED		VD8	O	D16	I/O	GPIO52	I/O

PT4CFG1	11		10		01		00	
	Name	Type	Name	Type	Name	Type	Name	Type
PORT4_1	RESERVED		VD9	O	D17	I/O	GPIO53	I/O

PT4CFG2	11		10		01		00	
	Name	Type	Name	Type	Name	Type	Name	Type
PORT4_2	RESERVED		VD10	O	D18	I/O	GPIO54	I/O

PT4CFG3	11		10		01		00	
	Name	Type	Name	Type	Name	Type	Name	Type
PORT4_3	RESERVED		VD11	O	D19	I/O	GPIO55	I/O

PT4CFG4	11		10		01		00	
	Name	Type	Name	Type	Name	Type	Name	Type
PORT4_4	RESERVED		VD12	O	D20	I/O	GPIO56	I/O

PT4CFG5	11		10		01		00	
	Name	Type	Name	Type	Name	Type	Name	Type
PORT4_5	RESERVED		VD13	O	D21	I/O	GPIO57	I/O

PT4CFG6	11		10		01		00	
	Name	Type	Name	Type	Name	Type	Name	Type
PORT4_6	RESERVED		VD14	O	D22	I/O	GPIO58	I/O

PT4CFG7	11		10		01		00	
	Name	Type	Name	Type	Name	Type	Name	Type
PORT4_7	RESERVED		VD15	O	D23	I/O	GPIO59	I/O

W90P710CD/W90P710CDG



PT4CFG8	11		10		01		00	
	Name	Type	Name	Type	Name	Type	Name	Type
PORT4_8	RESERVED		RESERVED		nWBE2/SDQM2	I/O	GPIO68	I/O

PT4CFG9	11		10		01		00	
	Name	Type	Name	Type	Name	Type	Name	Type
PORT4_9	RESERVED		RESERVED		nWBE3/SDQM3	I/O	GPIO69	I/O

PT4CFG10	11		10		01		00	
	Name	Type	Name	Type	Name	Type	Name	Type
PORT4_10	RESERVED		nIRQ5		nWAIT	I	GPIO70	I/O

GPIO Port4 Direction Register (GPIO_DIR4)

REGISTER	ADDRESS	R/W	DESCRIPTION	RESET VALUE
GPIO_DIR4	0xFFF8_3044	R/W	GPIO port4 in/out direction control and pull-up enable register	0x0000_0000

31	30	29	28	27	26	25	24
RESERVED					PUPEN4[10:8]		
23	22	21	20	19	18	17	16
PUPEN4[7:0]							
15	14	13	12	11	10	9	8
RESERVED					OMDEN4[10:8]		
7	6	5	4	3	2	1	0
OMDEN4[7:0]							

BITS	DESCRIPTION	
[31:27]	RESERVED	-
[26:16]	PUPEN4	GPIO70~GPIO68 and GPIO59~GPIO52 pin internal pull-up resistor enable 1 = Enable pull-up resistor 0 = Disable pull-up resistor
[15:11]	RESERVED	

W90P710CD/W90P710CDG



Continued

BITS	DESCRIPTION	
[10:0]	OMDEN4	<p>GPIO70~GPIO68 and GPIO59~GPIO52 output mode enable 1 = Enable GPIOx output mode 0 = GPIOx is input mode</p> <p>NOTE: Output mode enable bits are valid only when bit PT4CFG10-0 is configured as general purpose I/O mode.</p> <p>Each port pin can be enabled individually by setting the corresponding control bit.</p>

GPIO Port4 Data Output Register (GPIO_DATAOUT4)

REGISTER	ADDRESS	R/W	DESCRIPTION	RESET VALUE
GPIO_DATAOUT4	0xFFF8_3048	R/W	GPIO port4 data output register	0x0000_0000

31	30	29	28	27	26	25	24
RESERVED							
23	22	21	20	19	18	17	16
RESERVED							
15	14	13	12	11	10	9	8
RESERVED				DATAOUT4[10:8]			
7	6	5	4	3	2	1	0
DATAOUT4[7:0]							

BITS	DESCRIPTION	
[31:11]	RESERVED	-
[10:0]	DATAOUT4	<p>PORT4 data output value</p> <p>Writing data to this register reflects the data value on the corresponding port4 pin when it is configured as a general-purpose output pin. And writing data to reserved bits is not effective.</p>

GPIO Port4 Data Input Register (GPIO_DATAIN4)

REGISTER	ADDRESS	R/W	DESCRIPTION	RESET VALUE
GPIO_DATAIN4	0xFFF8_304C	R/W	GPIO port4 data input register	0xFFFF_XXXX

W90P710CD/W90P710CDG



31	30	29	28	27	26	25	24
RESERVED							
23	22	21	20	19	18	17	16
RESERVED							
15	14	13	12	11	10	9	8
RESERVED				DATAIN4[10:8]			
7	6	5	4	3	2	1	0
DATAIN3[7:0]							

BITS	DESCRIPTION	
[31:11]	RESERVED	-
[10:0]	DATAIN4	Port4 input data register DATAIN4 indicates the status of each GPIO52~GPIO59, GPIO68 and GPIO69 pin regardless of its operating mode. The reserved bits are read as 0s

GPIO Port5 Configuration Register (GPIO_CFG5)

REGISTER	ADDRESS	R/W	DESCRIPTION	RESET VALUE
GPIO_CFG5	0xFFF8_3050	R/W	GPIO port5 configuration register	0x0000_0000

31	30	29	28	27	26	25	24
RESERVED		PT5CFG14		PT5CFG13		PT5CFG12	
23	22	21	20	19	18	17	16
PT5CFG11		PT5CFG10		PT5CFG9		PT5CFG8	
15	14	13	12	11	10	9	8
PT5CFG7		PT5CFG6		PT5CFG5		PT5CFG4	
7	6	5	4	3	2	1	0
PT5CFG3		PT5CFG2		PT5CFG1		PT5CFG0	

*In the following pin definition, shaded functions are set by default.

PT5CFG0	11		10		01		00	
	Name	Type	Name	Type	Name	Type	Name	Type
PORT5_0	RESERVED		RESERVED		TXD0	O	GPIO5	I/O

W90P710CD/W90P710CDG



PT5CFG1	11		10		01		00	
	Name	Type	Name	Type	Name	Type	Name	Type
PORT5_1	RESERVED		RESERVED		RXD0	I	GPIO6	I/O

PT5CFG2	11		10		01		00	
	Name	Type	Name	Type	Name	Type	Name	Type
PORT5_2	RESERVED		RESERVED		TXD1	O	GPIO7	I/O

PT5CFG3	11		10		01		00	
	Name	Type	Name	Type	Name	Type	Name	Type
PORT5_3	RESERVED		RESERVED		RXD1	I	GPIO8	I/O

PT5CFG4	11		10		01		00	
	Name	Type	Name	Type	Name	Type	Name	Type
PORT5_4	PS2CLK	O	CTS1	I	TXD2	O	GPIO9	I/O

PT5CFG5	11		10		01		00	
	Name	Type	Name	Type	Name	Type	Name	Type
PORT5_5	PS2DATA	I/O	RTS1	O	RXD2	I	GPIO10	I/O

PT5CFG6	11		10		01		00	
	Name	Type	Name	Type	Name	Type	Name	Type
PORT5_6	TIMER0	O	SFRM	O	SCL0	I/O	GPIO11	I/O

PT5CFG7	11		10		01		00	
	Name	Type	Name	Type	Name	Type	Name	Type
PORT5_7	TIMER1	O	SSPTX D	O	SDA0	I/O	GPIO12	I/O

PT5CFG8	11		10		01		00	
	Name	Type	Name	Type	Name	Type	Name	Type
PORT5_8	KPROW3	O	SSPSCLK	O	SCL1	I/O	GPIO13	I/O

W90P710CD/W90P710CDG



PT5CFG9	11		10		01		00	
	Name	Type	Name	Type	Name	Type	Name	Type
PORT5_9	KPROW2	O	SSPRXD	I/O	SDA1	I/O	GPIO14	I/O

PT5CFG10	11		10		01		00	
	Name	Type	Name	Type	Name	Type	Name	Type
PORT5_10	RESERVED		USBPWREN	O	nWDOG	O	GPIO15	I/O

PT5CFG11	11		10		01		00	
	Name	Type	Name	Type	Name	Type	Name	Type
PORT5_11	RESERVED		RESERVED		nIRQ0	I	GPIO16	I/O

PT5CFG12	11		10		01		00	
	Name	Type	Name	Type	Name	Type	Name	Type
PORT5_12	RESERVED		USBOVCUR	I	nIRQ1	I	GPIO17	I/O

PT5CFG13	11		10		01		00	
	Name	Type	Name	Type	Name	Type	Name	Type
PORT5_13	RESERVED		RESERVED		nIRQ2	I	GPIO18	I/O

PT5CFG14	11		10		01		00	
	Name	Type	Name	Type	Name	Type	Name	Type
PORT5_14	RESERVED		RESERVED		nIRQ3	I	GPIO19	I/O

GPIO Port5 Direction Register (GPIO_DIR5)

REGISTER	ADDRESS	R/W	DESCRIPTION	RESET VALUE
GPIO_DIR5	0xFFF8_3054	R/W	GPIO port5 in/out direction control and pull-up enable register	0x0000_0000

W90P710CD/W90P710CDG



31	30	29	28	27	26	25	24
RESERVED	PUPEN5[14:8]						
23	22	21	20	19	18	17	16
PUPEN5[7:0]							
15	14	13	12	11	10	9	8
RESERVED	OMDEN5[14:8]						
7	6	5	4	3	2	1	0
OMDEN5[7:0]							

BITS	DESCRIPTION	
[31]	RESERVED	-
[30:16]	PUPEN5	GPIO19 ~ GPIO5 port pin internal pull-up resistor enable 1 = Enable pull-up resistor 0 = Disable pull-up resistor
[15]	RESERVED	-
[14:0]	OUTEN5	GPIO19 ~ GPIO5 output mode enable 1 = Enable GPIOx output mode 0 = GPIOx is input mode NOTE: Output mode enable bits are valid only when bit PT5CFG9-0 is configured as general purpose I/O mode. Each port pin can be enabled individually by setting the corresponding control bit.

GPIO Port5 Data Output Register (GPIO_DATAOUT5)

REGISTER	ADDRESS	R/W	DESCRIPTION	RESET VALUE
GPIO_DATAOUT5	0xFFF8_3058	R/W	GPIO port5 data output register	0x0000_0000

31	30	29	28	27	26	25	24
RESERVED							
23	22	21	20	19	18	17	16
RESERVED							
15	14	13	12	11	10	9	8
RESERVED	DATAOUT5[14:8]						
7	6	5	4	3	2	1	0
DATAOUT5[7:0]							

W90P710CD/W90P710CDG



BITS	DESCRIPTION	
[31:15]	RESERVED	-
[14:0]	DATAOUT5	PORT5 data output value Writing data to this register will reflect the data value on the corresponding port5 pin when it is configured as a general-purpose output pin. And writing data to reserved bits is not effective.

GPIO Port5 Data Input Register (GPIO_DATAIN5)

REGISTER	ADDRESS	R/W	DESCRIPTION	RESET VALUE
GPIO_DATAIN5	0xFFFF8_305C	R/W	GPIO port4 data input register	0XXXXX_XXXX

31	30	29	28	27	26	25	24
RESERVED							
23	22	21	20	19	18	17	16
RESERVED							
15	14	13	12	11	10	9	8
RESERVED	DATAIN5[14:8]						
7	6	5	4	3	2	1	0
DATAIN5[7:0]							

BITS	DESCRIPTION	
[31:15]	RESERVED	-
[14:0]	DATAIN5	Port5 input data register The DATAIN5 indicates the status of each GPIO19~GPIO5 pin regardless of its operating mode. The reserved bits are read as 0s.

GPIO Port6 Configuration Register (GPIO_CFG6)

REGISTER	ADDRESS	R/W	DESCRIPTION	RESET VALUE
GPIO_CFG6	0xFFFF8_3060	R/W	GPIO port6 configuration register	0x0000_0000

W90P710CD/W90P710CDG



31	30	29	28	27	26	25	24
RESERVED							
23	22	21	20	19	18	17	16
PT6CFG11		PT6CFG10		PT6CFG9		PT6CFG8	
15	14	13	12	11	10	9	8
PT6CFG7		PT6CFG6		PT6CFG5		PT6CFG4	
7	6	5	4	3	2	1	0
PT6CFG3		PT6CFG2		PT6CFG1		PT6CFG0	

*In the following pin definition, shaded functions are set by default.

PT6CFG0	11		10		01		00	
	Name	Type	Name	Type	Name	Type	Name	Type
PORT6_0	RESERVED		KPROW0	O	VCLK	O	GPIO30	I/O

PT6CFG1	11		10		01		00	
	Name	Type	Name	Type	Name	Type	Name	Type
PORT6_1	RESERVED		KPROW1	O	VDEN	O	GPIO31	I/O

PT6CFG2	11		10		01		00	
	Name	Type	Name	Type	Name	Type	Name	Type
PORT6_2	RESERVED		KPROW2	O	VSYNC	O	GPIO32	I/O

PT6CFG3	11		10		01		00	
	Name	Type	Name	Type	Name	Type	Name	Type
PORT6_3	RESERVED		KPROW3	O	HSYNC	O	GPIO33	I/O

PT6CFG4	11		10		01		00	
	Name	Type	Name	Type	Name	Type	Name	Type
PORT6_4	RESERVED		KPCOL0	I	VD0	O	GPIO34	I/O

W90P710CD/W90P710CDG



PT6CFG5	11		10		01		00	
	Name	Type	Name	Type	Name	Type	Name	Type
PORT6_5	RESERVED		KPCOL1	I	VD1	O	GPIO35	I/O

PT6CFG6	11		10		01		00	
	Name	Type	Name	Type	Name	Type	Name	Type
PORT6_6	RESERVED		KPCOL2	I	VD2	O	GPIO36	I/O

PT6CFG7	11		10		01		00	
	Name	Type	Name	Type	Name	Type	Name	Type
PORT6_7	RESERVED		KPCOL3	I	VD3	O	GPIO37	I/O

PT6CFG8	11		10		01		00	
	Name	Type	Name	Type	Name	Type	Name	Type
PORT6_8	RESERVED		KPCOL4	I	VD4	O	GPIO38	I/O

PT6CFG9	11		10		01		00	
	Name	Type	Name	Type	Name	Type	Name	Type
PORT6_9	RESERVED		KPCOL5	I	VD5	O	GPIO39	I/O

PT6CFG10	11		10		01		00	
	Name	Type	Name	Type	Name	Type	Name	Type
PORT6_10	RESERVED		KPCOL6	I	VD6	O	GPIO40	I/O

PT6CFG11	11		10		01		00	
	Name	Type	Name	Type	Name	Type	Name	Type
PORT6_11	RESERVED		KPCOL7	I	VD7	O	GPIO41	I/O

GPIO Port6 Direction Register (GPIO_DIR6)

REGISTER	ADDRESS	R/W	DESCRIPTION	RESET VALUE
GPIO_DIR6	0xFFF8_3064	R/W	GPIO port5 in/out direction control and pull-up enable register	0x0000_0000

W90P710CD/W90P710CDG



31	30	29	28	27	26	25	24
RESERVED				PUPEN6[11:8]			
23	22	21	20	19	18	17	16
PUPEN6[7:0]							
15	14	13	12	11	10	9	8
RESERVED				OMDEN6[11:8]			
7	6	5	4	3	2	1	0
OMDEN6[7:0]							

BITS	DESCRIPTION	
[31:27]	RESERVED	-
[26:16]	PUPEN6	GPIO30 ~GPIO41 port pin internal pull-up resistor enable 1 = Enable pull-up resistor 0 = Disable pull-up resistor
[15:13]	RESERVED	
[12:0]	OMDEN6	GPIO41 ~ GPIO30 output mode enable 1 = Enable GPIOx output mode 0 = GPIOx is input mode NOTE: Output mode enable bits are valid only when bit PT6CFG11-0 is configured as general purpose I/O mode. Each port pin can be enabled individually by setting the corresponding control bit.

GPIO Port6 Data Output Register (GPIO_DATAOUT6)

REGISTER	ADDRESS	R/W	DESCRIPTION	RESET VALUE
GPIO_DATAOUT6	0xFFF8_3068	R/W	GPIO port6 data output register	0x0000_0000

31	30	29	28	27	26	25	24
RESERVED							
23	22	21	20	19	18	17	16
RESERVED							
15	14	13	12	11	10	9	8
RESERVED				DATAOUT6[11:8]			
7	6	5	4	3	2	1	0
DATAOUT6[7:0]							

W90P710CD/W90P710CDG



BITS	DESCRIPTION	
[31:12]	RESERVED	-
[11:0]	DATAOUT6	PORT6 data output value Writing data to this register will reflect the data value on the corresponding port6 pin when it is configured as a general-purpose output pin. And writing data to reserved bits is not effective

GPIO Port6 Data Input Register (GPIO_DATAIN6)

REGISTER	ADDRESS	R/W	DESCRIPTION	RESET VALUE
GPIO_DATAIN6	0xFFFF8_306C	R/W	GPIO port6 data input register	0XXXXX_XXXX

31	30	29	28	27	26	25	24
RESERVED							
23	22	21	20	19	18	17	16
RESERVED							
15	14	13	12	11	10	9	8
RESERVED				DATAIN6[11:8]			
7	6	5	4	3	2	1	0
DATAIN6[7:0]							

BITS	DESCRIPTION	
[31:12]	RESERVED	-
[11:0]	DATAIN6	Port6 input data register DATAIN6 indicates the status of each GPIO18~GPIO5 pin regardless of its operating mode. Reserved bits are read as 0s.

GPIO Debounce Control Register (GPIO_DBNCECON)

REGISTER	ADDRESS	R/W	DESCRIPTION	RESET VALUE
GPIO_DBNCECON	0xFFFF8_3070	R/W	GPIO debounce control register	0XXXXX_XX00

W90P710CD/W90P710CDG



31	30	29	28	27	26	25	24
RESERVED							
23	22	21	20	19	18	17	16
RESERVED							
15	14	13	12	11	10	9	8
RESERVED							
7	6	5	4	3	2	1	0
RESERVED	DBCLKSEL			DBEN3	DBEN2	DBEN1	DBEN0

BITS	DESCRIPTION	
[31:7]	RESERVED	-
[6:4]	DBCLKSEL	Debounce Clock Selection These 3 bits are used to select the clock rate for the debounce circuit. The relationship between the system clock HCLK and the debounce clock TCLK_BUN is as follows: $T_{CLK_BUN} = HCLK / 2^{DBCLKSEL}$
[3]	DBEN3	Debounce circuit enable for GPIO19 (nIRQ3) 1 = Enable GPIO19 debounce function 0 = Disable GPIO19 debounce function
[2]	DBEN2	Debounce circuit enable for GPIO18 (nIRQ2) 1 = Enable GPIO18 debounce function 0 = Disable GPIO18 debounce function
[1]	DBEN1	Debounce circuit enable for GPIO17 (nIRQ1) 1 = Enable GPIO17 debounce function 0 = Disable GPIO17 debounce function
[0]	DBEN0	Debounce circuit enable for GPIO16 (nIRQ0) 1 = Enable GPIO16 debounce function 0 = Disable GPIO16 debounce function



GPIO Interrupt Configuration Register (GPIO_XICFG)

REGISTER	ADDRESS	R/W	DESCRIPTION	RESET VALUE
GPIO_XICFG	0xFFF8_3074	R/W	Extend Interrupt Configure Register	0XXXXX_XX00

31	30	29	28	27	26	25	24
RESERVED							
23	22	21	20	19	18	17	16
RESERVED							
15	14	13	12	11	10	9	8
RESERVED							
7	6	5	4	3	2	1	0
EnINT5	DBE5	ISTYPE5		EnINT4	DBE4	ISTYPE4	

BITS	DESCRIPTION	
[31:8]	RESERVED	-
[7]	EnINT5	<p>Enable INT5</p> <p>Setting this bit 1 to enable extend interrupt 5.</p> <p>1 = Enable interrupt 5 0 = Disable interrupt 5</p> <p>The AIC interrupt channel 31 is reserved for interrupt 5 and 4 (wired-OR), if this bit is set and interrupt 5 occurs, then it will send an interrupt request signal into the AIC module.</p>
[6]	DBE5	<p>Debounce circuit enable for INT5</p> <p>(alternative nWAIT pin function)</p> <p>Extended interrupt 5 shares the same debounce circuit with nIRQ[3:0], software can configure debounce sampling time in GPIO_DEBNCE control register. DBE5 function is the same as DBE0 in GPIO_DBENCE register.</p> <p>1 = Enable debounce 0 = Disable debounce</p>



Continued

BITS	DESCRIPTION											
[5:4]	STYPE5	<p>Interrupt 5 source type</p> <table border="1" data-bbox="727 474 1305 697"> <thead> <tr> <th>ISTYPE5</th> <th>Interrupt Source Type</th> </tr> </thead> <tbody> <tr> <td>2'b00</td> <td>LOW level sensitive</td> </tr> <tr> <td>2'b01</td> <td>HIGH level sensitive</td> </tr> <tr> <td>2'b10</td> <td>Negative edge triggered</td> </tr> <tr> <td>2'b11</td> <td>Positive edge triggered</td> </tr> </tbody> </table>	ISTYPE5	Interrupt Source Type	2'b00	LOW level sensitive	2'b01	HIGH level sensitive	2'b10	Negative edge triggered	2'b11	Positive edge triggered
ISTYPE5	Interrupt Source Type											
2'b00	LOW level sensitive											
2'b01	HIGH level sensitive											
2'b10	Negative edge triggered											
2'b11	Positive edge triggered											
[3]	EnINT4	<p>Enable INT4 Setting this bit to 1 enables extended interrupt 4 1 = Enable interrupt 4 0 = Disable interrupt 4 AIC interrupt channel 31 is reserved for interrupt 5 and 4 (wire-OR), if this bit is set and interrupt 4 occurs, then it will send an interrupt request signal into AIC module.</p>										
[2]	DBE4	<p>Debounce circuit enable for INT4 (GPIO0 pin alternative function) 1 = Enable debounce 0 = Disable debounce Extended interrupt 4 shares the same debounce circuit with nIRQ[3:0], software and can configure debounce sampling time in GPIO_DEBNCE control register. DBE5 function is the same as DBE0 in GPIO_DBENCE register.</p>										
[1:0]	ISTYPE4	<p>Interrupt 4 source type</p> <table border="1" data-bbox="727 1346 1305 1541"> <thead> <tr> <th>ISTYPE5</th> <th>Interrupt Source Type</th> </tr> </thead> <tbody> <tr> <td>2'b00</td> <td>LOW level sensitive</td> </tr> <tr> <td>2'b01</td> <td>HIGH level sensitive</td> </tr> <tr> <td>2'b10</td> <td>Negative edge triggered</td> </tr> <tr> <td>2'b11</td> <td>Positive edge triggered</td> </tr> </tbody> </table>	ISTYPE5	Interrupt Source Type	2'b00	LOW level sensitive	2'b01	HIGH level sensitive	2'b10	Negative edge triggered	2'b11	Positive edge triggered
ISTYPE5	Interrupt Source Type											
2'b00	LOW level sensitive											
2'b01	HIGH level sensitive											
2'b10	Negative edge triggered											
2'b11	Positive edge triggered											



GPIO Interrupt Status Register (GPIO_XISTATUS)

REGISTER	ADDRESS	R/W	DESCRIPTION	RESET VALUE
GPIO_XISTATUS	0xFFF8_3078	R/W	Extend interrupt status (flag) register	0xFFFF_XX00

31	30	29	28	27	26	25	24
RESERVED							
23	22	21	20	19	18	17	16
RESERVED							
15	14	13	12	11	10	9	8
RESERVED							
7	6	5	4	3	2	1	0
RESERVED						INT5	INT4

BITS	DESCRIPTION	
[31:2]	RESERVED	-
[1]	INT5	<p>Interrupt 5 status</p> <p>When an interrupt input is detected with ISTYPE5 triggered condition, this flag is set. It must be cleared by software.</p> <p>1 = interrupt detected.</p> <p>0 = No interrupt</p>
[0]	INT4	<p>Interrupt 4 status</p> <p>When interrupt input is detected with ISTYPE4 triggered condition, this flag is set. It must be cleared by software.</p> <p>1 = interrupt 4 is detected.</p> <p>0 = no interrupt</p>



6.16 Real Time Clock

The Real Time Clock (RTC) block can be operated by an independent power supply while the system power is off. The RTC block utilizes an external crystal to generate 32.768 KHz clock. The RTC can transmit data to the CPU as BCD values. The data includes the time by second, minute, hour and the date by day, month, and year. In addition, to reach better frequency accuracy, the RTC counter can be adjusted by software.

RTC features are shown as below:

- Timer counter (second, minute, hour) and calendar counter (day, month, year).
- Alarm register (second, minute, hour, day, month, year).
- 12/24-hour mode selectable.
- Recognize leap year automatically.
- Weekday counter.
- Frequency compensate register (RTC_FCR).
- Beside RTC_FCR, all clock and alarm data expressed in BCD code.
- Support two kinds of interrupt (tick and alarm)

RTC Initiation: When RTC block is powered on, programmer has to write a number (0xa5eb1357) to RTC_INIR to reset all logic. RTC_INIR act as hardware reset circuit. Once RTC_INIR has been set as 0xa5eb1357, user cannot reload any other value.

RTC write enable: Register RTC_AER bit 15~0 is RTC read /write password. It is used to avoid signal interference from the system during system power off. RTC_AER bit 15~0 has to be set as 0xa965 before the user can write new data to all registers besides RTC_INIR. If the user set RTC_AER as 0xa965, RTC_WRITE_EN is raised high. Then the user can feel free to write data to the register. RTC_WRITE_EN will keep high for a short period (about 24ms) and it is automatically pulled low by internal state machine.

Frequency Compensation: The RTC_FCR allows software controlled digital compensation of a 32.768 KHz crystal oscillator. User can utilize a frequency counter to measure the RTC clock in one of the GPIO pins during manufacture, and store the value in Flash memory for retrieval when the product is first power on.

Time and Calendar counter: RTC_TLR and RTC_CLR are used to load the time and calendar. RTC_TAR and RTC_CAR are used as alarm. They are all BCD counters.

12/24 hour Time scale selection: The 12/24 hour time scale selection depends on RTC_TSSR bit 0.

Weekday counter: Counts from Sunday to Saturday

W90P710CD/W90P710CDG



Tick interrupt: The RTC block uses a counter to calibrate the tick count value. When the value in the counter reaches zero, the RTC triggers an interrupt.

RTC register property: When the system power is off but the RTC power is on, the data stored in the RTC registers is not lost except RTC_TSSR, RTC_RIER and RTC_RIIR. Because of the difference between the RTC clock and system clock, every time the user writes new data to any register, the register is updated 2 RTC clock later (60us).

In addition, the user must be aware that the RTC block does not check whether the loaded data is out of bounds. The RTC does not check rationality between RTC_DWR and RTC_CLR either.

6.16.1 RTC Register Map

REGISTER	ADDRESS	R/W	DESCRIPTION	RESET VALUE
RTC_INIR	0xFFF8_4000	R/W	RTC Initiation Register	-
RTC_AER	0xFFF8_4004	R/W	RTC Access Enable Register	0x0000_0000
RTC_FCR	0xFFF8_4008	R/W	RTC Frequency Compensation Register	0x0000_0700
RTC_TLR	0xFFF8_400C	R/W	Time Loading Register	0x0000_0000
RTC_CLR	0xFFF8_4010	R/W	Calendar Loading Register	0x0005_0101
RTC_TSSR	0xFFF8_4014	R/W	Time Scale Selection Register	0x0000_0001
RTC_DWR	0xFFF8_4018	R/W	Weekday Register	0x0000_0006
RTC_TAR	0xFFF8_401C	R/W	Time Alarm Register	0x0000_0000
RTC_CAR	0xFFF8_4020	R/W	Calendar Alarm Register	0x0000_0000
RTC_LIR	0xFFF8_4024	R	Leap year Indicator Register	0x0000_0000
RTC_RIER	0xFFF8_4028	R/W	RTC Interrupt Enable Register	0x0000_0000
RTC_RIIR	0xFFF8_402C	R/C	RTC Interrupt Indicator Register	0x0000_0000
RTC_TTR	0xFFF8_4030	R/W	RTC Tick Register	0x0000_0000



RTC Initiation Register (RTC_INIR)

REGISTER	ADDRESS	R/W	DESCRIPTION	RESET VALUE
RTC_INIR	0xFFF8_4000	R/W	RTC Initiation Register	-

31	30	29	28	27	26	25	24
INIR[31:24]							
23	22	21	20	19	18	17	16
INIR[23:16]							
15	14	13	12	11	10	9	8
INIR[15:8]							
7	6	5	4	3	2	1	0
INIR[7:0]							

BITS	DESCRIPTIONS	
[31:0]	INIR	<p>INIR [31:0]: The INIR register is used to replace the hardware reset circuit. Programmer must write INIR as "0xa5eb_1357" after RTC is powered.</p> <p>INIR [0]: R/W. Once the RTC INIR is written, the user can access this bit to find out whether the RTC reset signal was pulled high.</p>

RTC Access Enable Register (RTC_AER)

REGISTER	ADDRESS	R/W	DESCRIPTION	RESET VALUE
RTC_AER	0xFFF8_4004	R/W	RTC Access Enable Register	0X0000_0000

31	30	29	28	27	26	25	24
Reserved							
23	22	21	20	19	18	17	16
Reserved							AER[16]
15	14	13	12	11	10	9	8
AER[15:8]							
7	6	5	4	3	2	1	0
AER[7:0]							



BITS	DESCRIPTIONS	
[31:17]	Reserved	-
[16:0]	AER	AER [16]: Read only 1 = RTC register write enable 0 = RTC register write disable AER[15:0]: Write only RTC register write enable/disable password 0xa965 = Write enable 0x0000 = Write disable

RTC Frequency Compensation Register (RTC_FCR)

REGISTER	ADDRESS	R/W	DESCRIPTION	RESET VALUE
RTC_FCR	0xFFF8_4008	R/W	RTC Frequency Compensation Register	0x0000_0700

31	30	29	28	27	26	25	24
Reserved							
23	22	21	20	19	18	17	16
Reserved							
15	14	13	12	11	10	9	8
Reserved				FCR_int			
7	6	5	4	3	2	1	0
Reserved		FCR_fra					



BITS	DESCRIPTIONS				
[31:12]	Reserved	-			
[11:8]	FCR_int	FCR [11:8]: Integer part			
		Integer part of detected value	FCR[11:8]	Integer part of detected value	FCR[11:8]
		32776	1111	32768	0111
		32775	1110	32767	0110
		32774	1101	32766	0101
		32773	1100	32765	0100
		32772	1011	32764	0011
		32771	1010	32763	0010
		32770	1001	32762	0001
32769	1000	32761	0000		
[5:0]	FCR_fra	Fraction part Formula: $FCR_int = (\text{fraction part of detected value}) \times 60$ Note: Digits in the FCR must be expressed as hexadecimal numbers.			
FCR Calibration	Example 1	Frequency counter measurement: 32773.65Hz Integer part: 32773 => FCR [11:8] = 0xc Fraction part: $0.65 \times 60 = 39(0x27) \Rightarrow FCR[5:0]=0x27$			
	Example 2	Frequency counter measurement: 32765.27Hz Integer part: 32765=> FCR [11:8] = 0x4 Fraction part: $0.27 \times 60 = 16.2(0x10) \Rightarrow FCR [5:0] = 0x10$			

RTC Time Loading Register (RTC_TLR)

REGISTER	ADDRESS	R/W	DESCRIPTION	RESET VALUE
RTC_TLR	0xFFF8_400C	R/W	RTC Time Loading Register	0X0000_0000

W90P710CD/W90P710CDG



31	30	29	28	27	26	25	24
Reserved							
23	22	21	20	19	18	17	16
Reserved		Hi_hr		Lo_hr			
15	14	13	12	11	10	9	8
Reserved	Hi_min			Lo_min			
7	6	5	4	3	2	1	0
Reserved	Hi_sec			Lo_sec			

Note: TLR is a BCD digit counter. The RTC does not check loaded data.

BITS	DESCRIPTIONS	
[21:20]	Hi_hr	10 hour time digit
[19:16]	Lo_hr	1 hour time digit
[14:12]	Hi_min	10 min time digit
[11:8]	Lo_min	1 min time digit
[6:4]	Hi_sec	10 sec time digit
[3:0]	Lo_sec	1 sec time digit

RTC Calendar Loading Register (RTC_CLR)

REGISTER	ADDRESS	R/W	DESCRIPTION	RESET VALUE
RTC_CLR	0xFFFF8_4010	R/W	RTC Calendar Loading Register	0X0005_0101

31	30	29	28	27	26	25	24
Reserved							
23	22	21	20	19	18	17	16
Hi_year				Lo_year			
15	14	13	12	11	10	9	8
Reserved			Hi_mon	Lo_mon			
7	6	5	4	3	2	1	0
Reserved		Hi_day		Lo_day			

Note: CLR is a BCD digit counter. The RTC does not check loaded data

W90P710CD/W90P710CDG



BITS	DESCRIPTIONS	
[23:20]	Hi_year	10-year calendar digit
[19:16]	Lo_year	1-year calendar digit
[12]	Hi_mon	10-month calendar digit
[11:8]	Lo_mon	1-month calendar digit
[5:4]	Hi_day	10-day calendar digit
[3:0]	Lo_day	1-day calendar digit

RTC Time Scale Selection Register (RTC_TSSR)

REGISTER	ADDRESS	R/W	DESCRIPTION	RESET VALUE
RTC_TSSR	0xFFF8_40014	R/W	Time Scale Selection Register	0X0000_0001

31	30	29	28	27	26	25	24
Reserved							
23	22	21	20	19	18	17	16
Reserved							
15	14	13	12	11	10	9	8
Reserved							
7	6	5	4	3	2	1	0
Reserved							24Hr/12Hr



BITS	DESCRIPTIONS																																																						
[31:1]	Reserved	-																																																					
[0]	24Hr/12Hr	<p>24Hr/12Hr: 24hour / 12 hour mode selection Indicates that TLR and TAR are in 24-hour mode or 12-hour mode 1 = Select 24-hour time scale 0 = Select 12-hour time scale with am and pm indication</p> <table border="1" data-bbox="561 709 1393 1375"> <thead> <tr> <th>24-hour time scale</th> <th>12-hour time scale</th> <th>24-hour time scale</th> <th>12-hour time scale</th> </tr> </thead> <tbody> <tr><td>00</td><td>12(AM12)</td><td>12</td><td>32(PM12)</td></tr> <tr><td>01</td><td>01(AM01)</td><td>13</td><td>21(PM01)</td></tr> <tr><td>02</td><td>02(AM02)</td><td>14</td><td>22(PM02)</td></tr> <tr><td>03</td><td>03(AM03)</td><td>15</td><td>23(PM03)</td></tr> <tr><td>04</td><td>04(AM04)</td><td>16</td><td>24(PM04)</td></tr> <tr><td>05</td><td>05(AM05)</td><td>17</td><td>25(PM05)</td></tr> <tr><td>06</td><td>06(AM06)</td><td>18</td><td>26(PM06)</td></tr> <tr><td>07</td><td>07(AM07)</td><td>19</td><td>27(PM07)</td></tr> <tr><td>08</td><td>08(AM08)</td><td>20</td><td>28(PM08)</td></tr> <tr><td>09</td><td>09(AM09)</td><td>21</td><td>29(PM09)</td></tr> <tr><td>10</td><td>10(AM10)</td><td>22</td><td>30(PM10)</td></tr> <tr><td>11</td><td>11(AM11)</td><td>23</td><td>31(PM11)</td></tr> </tbody> </table>		24-hour time scale	12-hour time scale	24-hour time scale	12-hour time scale	00	12(AM12)	12	32(PM12)	01	01(AM01)	13	21(PM01)	02	02(AM02)	14	22(PM02)	03	03(AM03)	15	23(PM03)	04	04(AM04)	16	24(PM04)	05	05(AM05)	17	25(PM05)	06	06(AM06)	18	26(PM06)	07	07(AM07)	19	27(PM07)	08	08(AM08)	20	28(PM08)	09	09(AM09)	21	29(PM09)	10	10(AM10)	22	30(PM10)	11	11(AM11)	23	31(PM11)
24-hour time scale	12-hour time scale	24-hour time scale	12-hour time scale																																																				
00	12(AM12)	12	32(PM12)																																																				
01	01(AM01)	13	21(PM01)																																																				
02	02(AM02)	14	22(PM02)																																																				
03	03(AM03)	15	23(PM03)																																																				
04	04(AM04)	16	24(PM04)																																																				
05	05(AM05)	17	25(PM05)																																																				
06	06(AM06)	18	26(PM06)																																																				
07	07(AM07)	19	27(PM07)																																																				
08	08(AM08)	20	28(PM08)																																																				
09	09(AM09)	21	29(PM09)																																																				
10	10(AM10)	22	30(PM10)																																																				
11	11(AM11)	23	31(PM11)																																																				

W90P710CD/W90P710CDG



RTC Weekday Register (RTC_DWR)

REGISTER	ADDRESS	R/W	DESCRIPTION	RESET VALUE
RTC_DWR	0xFFF8_4018	R/W	Weekday Register	0X0000_0006

31	30	29	28	27	26	25	24
Reserved							
23	22	21	20	19	18	17	16
Reserved							
15	14	13	12	11	10	9	8
Reserved							
7	6	5	4	3	2	1	0
Reserved					DWR[2:0]		

BITS	DESCRIPTIONS	
[31:3]	Reserved	-
[2:0]	DWR	DWR[2:0] : Weekday Register
		0 Sunday
		1 Monday
		2 Tuesday
		3 Wednesday
		4 Thursday
		5 Friday
		6 Saturday

RTC Time Alarm Register (RTC_TAR)

REGISTER	ADDRESS	R/W	DESCRIPTION	RESET VALUE
RTC_TAR	0xFFF8_401C	R/W	RTC Time Alarm Register	0x0000_0000

31	30	29	28	27	26	25	24
Reserved							
23	22	21	20	19	18	17	16
Reserved		Hi_hr_alarm			Hi_hr_alarm		
15	14	13	12	11	10	9	8
Reserved	Hi_min_alarm			Lo_min_alarm			
7	6	5	4	3	2	1	0
Reserved	Hi_sec_alarm			Lo_sec_alarm			

W90P710CD/W90P710CDG



TAR is a BCD digit register. The RTC does not check loaded data

BITS	DESCRIPTIONS	
[31:22]	Reserved	-
[21:20]	Hi_hr_alarm	10 hour time digit
[19:16]	Lo_hr_alarm	1 hour time digit
[15]	Reserved	-
[14:12]	Hi_min_alarm	10 min time digit
[11:8]	Lo_min_alarm	1 min time digit
[7]	Reserved	-
[6:4]	Hi_sec_alarm	10 sec time digit
[3:0]	Lo_sec_alarm	1 sec time digit

RTC Calendar Alarm Register (RTC_CAR)

REGISTER	ADDRESS	R/W	DESCRIPTION	RESET VALUE
RTC_CAR	0xFFF8_4020	R/W	RTC Calendar Alarm Register	0x0000_0000

31	30	29	28	27	26	25	24
Reserved							
23	22	21	20	19	18	17	16
Hi_year_alarm				Lo_year_alarm			
15	14	13	12	11	10	9	8
Reserved			Hi_mon_alarm	Lo_mon_alarm			
7	6	5	4	3	2	1	0
Reserved		Hi_day_alarm		Lo_day_alarm			

CAR is a BCD digit register and RTC will not check loaded data.

BITS	DESCRIPTIONS
------	--------------

W90P710CD/W90P710CDG



[31:24]	Reserved	-
[23:20]	Hi_year	10-year calendar digit
[19:16]	Lo_year	1-year calendar digit
[15:13]	Reserved	-
[12]	Hi_mon	10-month calendar digit
[11:8]	Lo_mon	1-month calendar digit
[5:4]	Hi_day	10-day calendar digit
[3:0]	Lo_day	1-day calendar digit

RTC Leap year Indication Register (RTC_LIR)

REGISTER	ADDRESS	R/W	DESCRIPTION	RESET VALUE
RTC_LIR	0xFFF8_4024	R	RTC Leap year Indication Register	0X0000_0000

31	30	29	28	27	26	25	24
Reserved							
23	22	21	20	19	18	17	16
Reserved							
15	14	13	12	11	10	9	8
Reserved							
7	6	5	4	3	2	1	0
Reserved							LIR[0]

BITS	DESCRIPTIONS	
[31:1]	Reserved	-
[0]	LIR	LIR [0]: Real only. Leap year Indication 1 = Indicates this year is a leap year 0 = Indicates this year is not a leap year



RTC Interrupt Enable Register (RTC_RIER)

REGISTER	ADDRESS	R/W	DESCRIPTION	RESET VALUE
RTC_RIER	0xFFF8_4028	R/W	RTC Interrupt Enable Register	0X0000_0000

31	30	29	28	27	26	25	24
Reserved							
23	22	21	20	19	18	17	16
Reserved							
15	14	13	12	11	10	9	8
Reserved							
7	6	5	4	3	2	1	0
Reserved						Tick_int_en	Alarm_int_en

BITS	DESCRIPTIONS	
[31:2]	Reserved	-
[1]	Tick_int_en	1 = RTC Tick Interrupt and counter enable 0 = RTC Tick Interrupt and counter disable
[0]	Alarm_int_en	1 = RTC Alarm Interrupt enable 0 = RTC Alarm Interrupt disable

RTC Interrupt Indication Register (RTC_RIIR)

REGISTER	ADDRESS	R/W	DESCRIPTION	RESET VALUE
RTC_RIIR	0xFFF8_402C	R/C	RTC Interrupt Indication Register	0X0000_0000

31	30	29	28	27	26	25	24
Reserved							
23	22	21	20	19	18	17	16
Reserved							
15	14	13	12	11	10	9	8
Reserved							
7	6	5	4	3	2	1	0
Reserved						Tick_int_st	Alarm_int_st



BITS		DESCRIPTIONS
[31:2]	Reserved	-
[1]	Tick_int_st	RTC Tick Interrupt Indication REGISTER 1 = Indicates the time tick interrupt has been activated. 0 = Indicates the tick interrupt did not occur.
[0]	Alarm_int_st	RTC Alarm Interrupt Indication 1 = Indicates the timer and calendar counter have counted to a specified time recorded in TAR and CAR. The RTC alarm interrupt is triggered. 0 = Indicates the alarm interrupt did not occur.
Note : User can clear these two bits by writing 0x0 to RIIR		

RTC Tick Time Register (RTC_TTR)

REGISTER	ADDRESS	R/W	DESCRIPTION	RESET VALUE
RTC_TTR	0xFFF8_4030	R/W	RTC Tick Register	0x0000_0000

31	30	29	28	27	26	25	24
Reserved							
23	22	21	20	19	18	17	16
Reserved							
15	14	13	12	11	10	9	8
Reserved							
7	6	5	4	3	2	1	0
Reserved					TTI		



BITS	DESCRIPTIONS																			
[31:3]	Reserved	-																		
[2:0]	TTI	<p>RTC Tick Interrupt request Interval The TTR [2:0] is used to select tick interrupt request interval. The period of tick interrupt is as follow:</p> <table border="1" data-bbox="643 674 1330 1094"> <thead> <tr> <th>TTR[2:0]</th> <th>Tick Interrupt interval</th> </tr> </thead> <tbody> <tr> <td>0</td> <td>1 sec</td> </tr> <tr> <td>1</td> <td>1/2 sec</td> </tr> <tr> <td>2</td> <td>1/4 sec</td> </tr> <tr> <td>3</td> <td>1/8 sec</td> </tr> <tr> <td>4</td> <td>1/16 sec</td> </tr> <tr> <td>5</td> <td>1/32 sec</td> </tr> <tr> <td>6</td> <td>1/64 sec</td> </tr> <tr> <td>7</td> <td>1/128 sec</td> </tr> </tbody> </table>	TTR[2:0]	Tick Interrupt interval	0	1 sec	1	1/2 sec	2	1/4 sec	3	1/8 sec	4	1/16 sec	5	1/32 sec	6	1/64 sec	7	1/128 sec
TTR[2:0]	Tick Interrupt interval																			
0	1 sec																			
1	1/2 sec																			
2	1/4 sec																			
3	1/8 sec																			
4	1/16 sec																			
5	1/32 sec																			
6	1/64 sec																			
7	1/128 sec																			

W90P710CD/W90P710CDG



6.16.2 RTC Application Note

Detect RTC frequency

Step1. Configure GPIO register GPIOCFG5 [21:20] as "2'b11"

Step2. Making use of the frequency counter (for example: Agilent 53131A) to detect W90P710 IO Pin "GPIO15/nWDOG/USBPWREN".

Note: Because the parasitic capacitance would slow crystal oscillation, do not connect the probe with 32K crystal directly.

RTC application circuit

1. The recommended RTC application circuit is as follows:

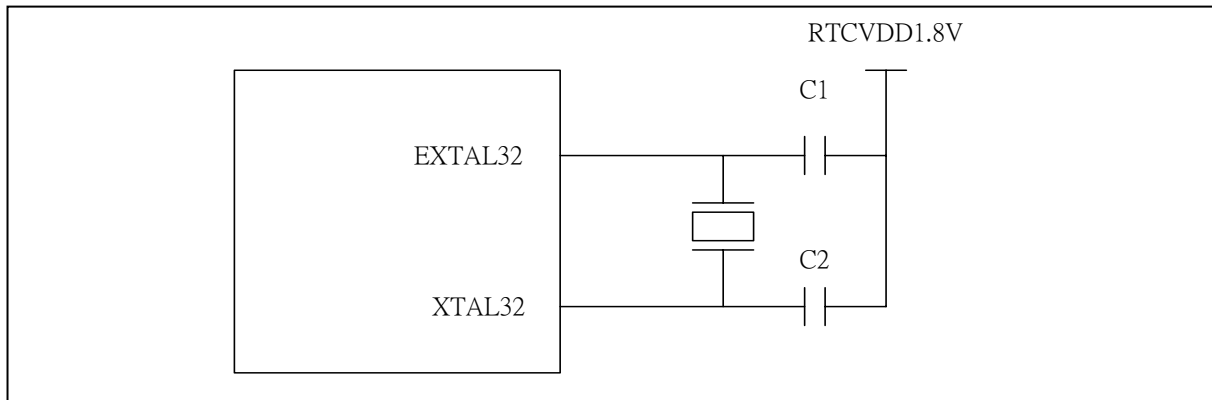

2. C1 and C2 cannot be connected to ground for improving the noise issue.
3. Do not connect any resistor in the circuit. Redundant resistor may stop crystal oscillation.
4. To avoid parasitic capacitance and resistance, the user should place all components as close as possible.
5. The C1 and C2 value can be changed with different crystals because different crystals require different oscillation conditions. In general, the capacitance value of C1/C2 is between 10pF and 30pF.



6.17 Smart Card Host Interface

The Smart Card resides in APB bus.

Smart Card Interface port pins in W90P710 that operates at 3.3V with 5V input tolerance, the smart card can interface to W90P710 directly regardless it output high is 5v or 3v.. Advanced power management features further optimize power consumption whether during operation or powering down.

- ISO-7816 compliant
- PC/SC T=0, T=1 compliant
- 16-byte transmitter FIFO and 16-byte receiver FIFO
- FIFO threshold interrupt to optimize system performance
- Programmable transmission clock frequency
- Versatile baud rate configuration
- UART-like register file structure
- Versatile 8-bit, 16-bit, 24-bit timer for Answer-To-Reset (ATR) and processing wait-times.
- Parity error counters during reception mode and in transmission mode with automatic re-transmission.
- Automatic activation and deactivation sequence through an independence sequencer

6.17.1 Register Mapping

R: read only, **W**: write only, **R/W**: both read and write, **C**: Only value 0 can be written.

Table 6.12.2.1 Smart Card Host Interface 0 Register Map

REGISTER	ADDRESS	R/W	DESCRIPTION	RESET VALUE
Smartcard Host Interface 0				
SCHI_RBR0	0xFFFF8_5000 (BDLAB=0)	R	Receiver Buffer Register	Undefined
SCHI_TBR0	0xFFFF8_5000 (BDLAB=0)	W	Transmitter Buffer Register	Undefined
SCHI_IER0	0xFFFF8_5004 (BDLAB=0)	R/W	Interrupt Enable Register	0x0000_0080
SCHI_ISR0	0xFFFF8_5008 (BDLAB=0)	R	Interrupt Status Register	0X0000_00C1
SCHI_SCFR0	0xFFFF8_5008 (BDLAB=0)	W	Smart card FIFO Control Register	0x0000_0000
SCHI_SCCR0	0xFFFF8_500C	R/W	Smart card Control Register	0x0000_0018
SCHI_CBR0	0xFFFF8_5010	R/W	Clock Base Register	0x0000_000C
SCHI_SCSR0	0xFFFF8_5014	R	Smart Card Status Register	0x0000_0060
SCHI_GTR0	0xFFFF8_5018	R/W	Guard Rime Register	0x0000_0001
SCHI_ECR0	0xFFFF8_501C	R/W	Extended Control Register	0x0000_0052
SCHI_TMR0	0xFFFF8_5020	R/W	Test Mode Register	0x0000_0000
SCHI_TOC0	0xFFFF8_5028	R/W	Time out Configuration Register	0x0000_0000

W90P710CD/W90P710CDG



Table 6.12.2.1 Smart Card Host Interface 0 Register Map, continued

REGISTER	ADDRESS	R/W	DESCRIPTION	RESET VALUE
SCHI_TOIR0_0	0xFFFF8_502C	R/W	Time out Initial Register 0	0x0000_0000
SCHI_TOIR1_0	0xFFFF8_5030	R/W	Time out Initial Register 1	0x0000_0000
SCHI_TOIR2_0	0xFFFF8_5034	R/W	Time out Initial Register 2	0x0000_0000
SCHI_TOD0_0	0xFFFF8_5038	R	Time out Data Register 0	0x0000_00FF
SCHI_TOD1_0	0xFFFF8_503C	R	Time out Data Register 1	0x0000_00FF
SCHI_TOD2_0	0xFFFF8_5040	R	Time out Data Register 2	0x0000_00FF
SCHI_BTOR_0	0xFFFF8_5044	R/W	Buffer Time out Data Register	0x0000_0000
SCHI_BLL_0	0xFFFF8_5000 (BDLAB=1)	R/W	Baud Rate Divisor Latch Lower Byte Register	0x0000_001F
SCHI_BLH_0	0xFFFF8_5004 (BDLAB=1)	R/W	Baud Rate Divisor Latch Higher Byte Register	0x0000_0000
SCHI_ID_0	0xFFFF8_5008 (BDLAB=1)	R	Smart Card ID Number Register	0x0000_0070
Smartcard Host Interface 1				
SCHI_RBR1	0xFFFF8_5800 (BDLAB=0)	R	Receiver Buffer Register	Undefined
SCHI_TBR1	0xFFFF8_5800 (BDLAB=0)	W	Transmitter Buffer Register	Undefined
SCHI_IER1	0xFFFF8_5804 (BDLAB=0)	R/W	Interrupt Enable Register	0x0000_0080
SCHI_ISR1	0xFFFF8_5808 (BDLAB=0)	R	Interrupt Status Register	0X0000_00C1
SCHI_SCFR1	0xFFFF8_5808 (BDLAB=0)	W	Smart card FIFO Control Register	0x0000_0000
SCHI_SCCR1	0xFFFF8_580C	R/W	Smart card Control Register	0x0000_0018
SCHI_CBR1	0xFFFF8_5810	R/W	Clock Base Register	0x0000_000C
SCHI_SCSR1	0xFFFF8_5814	R	Smart Card Status Register	0x0000_0060
SCHI_GTR1	0xFFFF8_5818	R/W	Guard Rime Register	0x0000_0001
SCHI_ECR1	0xFFFF8_581C	R/W	Extended Control Register	0x0000_0052
SCHI_TMR1	0xFFFF8_5820	R/W	Test Mode Register	0x0000_0000
SCHI_TOC1	0xFFFF8_5828	R/W	Time out Configuration Register	0x0000_0000
SCHI_TOIR0_1	0xFFFF8_582C	R/W	Time out Initial Register 0	0x0000_0000
SCHI_TOIR1_1	0xFFFF8_5830	R/W	Time out Initial Register 1	0x0000_0000
SCHI_TOIR2_1	0xFFFF8_5834	R/W	Time out Initial Register 2	0x0000_0000
SCHI_TOD0_1	0xFFFF8_5838	R	Time out Data Register 0	0x0000_00FF
SCHI_TOD1_1	0xFFFF8_583C	R	Time out Data Register 1	0x0000_00FF
SCHI_TOD2_1	0xFFFF8_5840	R	Time out Data Register 2	0x0000_00FF
SCHI_BTOR1	0xFFFF8_5844	R/W	Buffer Time out Data Register	0x0000_0000
SCHI_BLL1	0xFFFF8_5800 (BDLAB=1)	R/W	Baud Rate Divisor Latch Lower Byte Register	0x0000_001F
SCHI_BLH1	0xFFFF8_5804 (BDLAB=1)	R/W	Baud Rate Divisor Latch Higher Byte Register	0x0000_0000
SCHI_ID1	0xFFFF8_5808 (BDLAB=1)	R	Smart Card ID Number Register	0x0000_0070



6.17.2 Register Description

Receive Buffer Register (SCHI_RBR)

REGISTER	ADDRESS	R/W	DESCRIPTION	RESET VALUE
SCHI_RBR0	0xFFF8_5000 (DLAB = 0)	R	Receiver Buffer Register 0	Undefined
SCHI_RBR1	0xFFF8_5800 (DLAB = 0)	R	Receiver Buffer Register 1	Undefined

31	30	29	28	27	26	25	24
RESERVED							
23	22	21	20	19	18	17	16
RESERVED							
15	14	13	12	11	10	9	8
RESERVED							
7	6	5	4	3	2	1	0
RxBDATA[7:0]							

BITS	DESCRIPTIONS	
[31:8]	RESERVED	-
[7:0]	RxBDATA	<p>8-bit Received Data</p> <p>By reading this register, the SCHI will return an 8-bit data received from SCx_DAT pin.</p> <p>This register is the access port for receiver FIFO. The depth of receiver FIFO is 16 bytes.</p>

Transmit Buffer Register (SCHI_TBR)

REGISTER	ADDRESS	R/W	DESCRIPTION	RESET VALUE
SCHI_TBR0	0xFFF8_5000(DLAB = 0)	W	Transmit Buffer Register 0	Undefined
SCHI_TBR1	0xFFF8_5800(DLAB = 0)	W	Transmit Buffer Register 1	Undefined

W90P710CD/W90P710CDG



31	30	29	28	27	26	25	24
RESERVED							
23	22	21	20	19	18	17	16
RESERVED							
15	14	13	12	11	10	9	8
RESERVED							
7	6	5	4	3	2	1	0
TxBDATA[7:0]							

BITS	DESCRIPTIONS	
[31:8]	RESERVED	-
[7:0]	TxBDATA	<p>8-bit Transmit Buffer Data</p> <p>By writing to this register, the SCHI will send 8-bit data through the SCx_DAT pin.</p> <p>This register is the access port for transmitter FIFO. The depth of transmitter FIFO is 16 bytes.</p>

Interrupt Enable register (SCHI_IER)

REGISTER	ADDRESS	R/W	DESCRIPTION	RESET VALUE
SCHI_IER0	0xFFFF8_5004 (DLAB = 0)	R/W	Interrupt Enable Register 0	0x0000_0080
SCHI_IER1	0xFFFF8_5804 (DLAB = 0)	R/W	Interrupt Enable Register 1	0x0000_0080

31	30	29	28	27	26	25	24
RESERVED							
23	22	21	20	19	18	17	16
RESERVED							
15	14	13	12	11	10	9	8
RESERVED					ETOR2	ETOR1	ETOR0
7	6	5	4	3	2	1	0
PWRDN	Interface	RESERVED		ESCPTI	ESCSRI	ETBREI	ERDRI

W90P710CD/W90P710CDG



BITS	DESCRIPTIONS	
[31:11]	RESERVED	-
[10]	ETOR2	<p>TOR2 interrupt enable bit</p> <p>When 24-bit countdown timer reaches zero, it sets TO2 flag to high. If we set ETOR2 to high, then the 24-bit timer interrupts the CPU to indicate timeout.</p>
[9]	ETOR1	<p>TOR1 interrupt enable bit</p> <p>When the 16-bit countdown timer reaches zero, it will set TO1 flag to high. If we set ETOR1 to high, then the 16-bit timer interrupts the CPU to indicate timeout.</p>
[8]	ETOR0	<p>TOR0 interrupt enable bit</p> <p>When 8 bit countdown timer reaches zero, it will set the TO0 flag to high. If we set ETOR0 to high, then the 8-bit timer interrupts the CPU to indicate timeout.</p>
[7]	PWRDN	<p>Smart card POWER DOWN bit</p> <p>PWRDN is used when the Smartcard controller needs to be powered down. Powering down must be done whenever the controller needs to switch between class A and B. When this bit is a 1, it will deactivate all contacts to the Smartcard except for SCRST_L, which is discussed later. When the Smartcard is removed, the H/W will also set the POWER DOWN bit.</p>
[6]	Interface	<p>Smart card different interface bit</p> <p>Interface is used for controlling the different power control device signals. When set to 1, a power control pin is set to active high by the controller. When 0, the power control pin is active low to meet the needs of different power control interfaces.</p>
[5:4]	RESERVED	Reserved for future
[3]	ESCPTI	<p>Smart card present toggle interrupt enable bit</p> <p>A rising/falling edge of SCPSNT signal triggers an interrupt if this bit is set to 1.</p> <p>0 = SCPSNT toggle interrupt is disabled.</p> <p>1 = SCPSNT toggle interrupt is enabled.</p>
[2]	ESCSRI	<p>Enable SCSR interrupt bit</p> <p>An ESCSRI means interrupt enable bit for SCSR-related events such as silent byte detected error, no stop bit error, parity bit error or overrun error. Any SCSR-related event as described above will trigger an interrupt if this bit is set to 1.</p> <p>0 = SCSR-related event interrupt is disabled.</p> <p>1 = SCSR-related event interrupt is enabled.</p>



Continued

BITS		DESCRIPTIONS
[1]	ETBREI	<p>Enable Transmit Buffer Empty interrupt bit</p> <p>An ETBREI means interrupt enable bit for TBR (Transmitter Buffer Register) empty condition. An interrupt is issued when TBR is empty and this bit is set to 1.</p> <p>0 = TBR empty interrupt is disabled. 1 = TBR empty interrupt is enabled.</p>
[0]	ERDRI	<p>Enable Receive Data Ready interrupt bit</p> <p>The active FIFO threshold level for this kind of interrupt when FIFO is enabled is specified in RxTL1 and RxTL0 (bit 7 and bit 6 of the SCFR at base address+8, please refer to the SCFR description for more details). An interrupt is issued if a data byte is ready for host to read when FIFO is disabled or incoming data from the card reaches an active FIFO threshold level when FIFO is enabled.</p>

Interrupt Status Register (SCH_I_SR)

REGISTER	ADDRESS	R/W	DESCRIPTION	RESET VALUE
SCHI_ISR0	0xFFF8_5008 (DLAB = 0)	R	Interrupt Status Register 0	0x0000_00C1
SCHI_ISR1	0xFFF8_5808 (DLAB = 0)	R	Interrupt Status Register 1	0x0000_00C1

31	30	29	28	27	26	25	24
RESERVED							
23	22	21	20	19	18	17	16
RESERVED							
15	14	13	12	11	10	9	8
RESERVED							
7	6	5	4	3	2	1	0
RESERVED		SCPSNT	SCPTI	INTS2	INTS1	INTS0	Interrupt pending

This register contains mainly interrupt status including transmission-related interrupts and SCPSNT toggle interrupt. Transmission-related interrupt status is coded and prioritized as in UART implementation. The user may also find FIFO enable/disabled status reflecting what is set in bit 0 of the SCFR (write only Smart Card FIFO Register at base address + 8 when BDLAB = 0) and SCPSNT line status.



BITS		DESCRIPTIONS																																																																								
[31:6]	RESERVED	-																																																																								
[5]	SCPSNT	<p>Smart card present line status. User may poll this bit to see the SCPSNT pin's voltage level 0 = Smart card is not connected to the reader 1 = Smart card IC is connected to the reader</p>																																																																								
[4]	SCPTI	<p>SCPSNT toggle interrupt status. A rising/falling edge of SCPSNT signal triggers an interrupt and set this status bit if ESCPTI (IER bit 3) is set to 1 to enable SCPSNT toggle interrupt. 0= No SCPSNT toggle interrupt. 1 = SCPSNT toggle interrupt occurs.</p>																																																																								
[3:1]	INTS2 INTS0	<p>Interrupt Status bit 2 ~0 The combination indicates which kind of transmission-related interrupt has occurred. Refer to the following table for details.</p> <table border="1"> <thead> <tr> <th colspan="4">ISR bit</th> <th colspan="4">Interrupt set and function</th> </tr> <tr> <th>3</th> <th>2</th> <th>1</th> <th>0</th> <th>Priority</th> <th>Interrupt type</th> <th>Interrupt source</th> <th>Clear interrupt condition</th> </tr> </thead> <tbody> <tr> <td>0</td> <td>0</td> <td>0</td> <td>1</td> <td>-</td> <td>-</td> <td>No interrupt pending</td> <td>-</td> </tr> <tr> <td>1</td> <td>0</td> <td>1</td> <td>0</td> <td>first</td> <td>Card insert or remove</td> <td>SCPTI =1</td> <td>Read ISR</td> </tr> <tr> <td>1</td> <td>1</td> <td>1</td> <td>0</td> <td>second</td> <td>TIME-OUT interrupt</td> <td>1. TO2 =1 2. TO1 =1 3. TO0 =1</td> <td>Read SCSR</td> </tr> <tr> <td>0</td> <td>1</td> <td>1</td> <td>0</td> <td>third</td> <td>Data receiving status</td> <td>1. OER = 1 2. PBER = 1 3. NSER = 1 4. SBD = 1</td> <td>Read SCSR</td> </tr> <tr> <td>0</td> <td>1</td> <td>0</td> <td>0</td> <td>fourth</td> <td>RBR data ready</td> <td>1. RBR data ready 2. FIFO interrupt active level reached</td> <td>1. Read RBR 2. Read RBR until FIFO is under active level</td> </tr> <tr> <td>1</td> <td>1</td> <td>0</td> <td>0</td> <td>fifth</td> <td>FIFO data time out</td> <td>Receiver FIFO is non-empty and no activities are occurred in the receiver FIFO during the TOR defined time duration</td> <td>Read RBR</td> </tr> <tr> <td>0</td> <td>0</td> <td>1</td> <td>0</td> <td>sixth</td> <td>TBR empty</td> <td>TBR empty</td> <td>1. Write data to TBR 2. Read ISR (if priority is sixth)</td> </tr> </tbody> </table>	ISR bit				Interrupt set and function				3	2	1	0	Priority	Interrupt type	Interrupt source	Clear interrupt condition	0	0	0	1	-	-	No interrupt pending	-	1	0	1	0	first	Card insert or remove	SCPTI =1	Read ISR	1	1	1	0	second	TIME-OUT interrupt	1. TO2 =1 2. TO1 =1 3. TO0 =1	Read SCSR	0	1	1	0	third	Data receiving status	1. OER = 1 2. PBER = 1 3. NSER = 1 4. SBD = 1	Read SCSR	0	1	0	0	fourth	RBR data ready	1. RBR data ready 2. FIFO interrupt active level reached	1. Read RBR 2. Read RBR until FIFO is under active level	1	1	0	0	fifth	FIFO data time out	Receiver FIFO is non-empty and no activities are occurred in the receiver FIFO during the TOR defined time duration	Read RBR	0	0	1	0	sixth	TBR empty	TBR empty	1. Write data to TBR 2. Read ISR (if priority is sixth)
ISR bit				Interrupt set and function																																																																						
3	2	1	0	Priority	Interrupt type	Interrupt source	Clear interrupt condition																																																																			
0	0	0	1	-	-	No interrupt pending	-																																																																			
1	0	1	0	first	Card insert or remove	SCPTI =1	Read ISR																																																																			
1	1	1	0	second	TIME-OUT interrupt	1. TO2 =1 2. TO1 =1 3. TO0 =1	Read SCSR																																																																			
0	1	1	0	third	Data receiving status	1. OER = 1 2. PBER = 1 3. NSER = 1 4. SBD = 1	Read SCSR																																																																			
0	1	0	0	fourth	RBR data ready	1. RBR data ready 2. FIFO interrupt active level reached	1. Read RBR 2. Read RBR until FIFO is under active level																																																																			
1	1	0	0	fifth	FIFO data time out	Receiver FIFO is non-empty and no activities are occurred in the receiver FIFO during the TOR defined time duration	Read RBR																																																																			
0	0	1	0	sixth	TBR empty	TBR empty	1. Write data to TBR 2. Read ISR (if priority is sixth)																																																																			
[0]	Interrupt pending	<p>Interrupt pending status bit. This bit is logical 1 if there is no interrupt pending. If an interrupt occurs, this bit is set to 0. 0 = Interrupt pending. 1 = No interrupt occurs.</p>																																																																								



Smart Card FIFO control Register (SCHL_SCFR)

REGISTER	ADDRESS	R/W	DESCRIPTION	RESET VALUE
SCHL_SCFR0	0xFFF8_5008 (DLAB = 0)	W	Interrupt Status Register 0	0x0000_0000
SCHL_SCFR1	0xFFF8_5808 (DLAB = 0)	W	Interrupt Status Register 1	0x0000_0000

31	30	29	28	27	26	25	24
RESERVED							
23	22	21	20	19	18	17	16
RESERVED							
15	14	13	12	11	10	9	8
RESERVED							
7	6	5	4	3	2	1	0
RxTL1	RxTL0	PEC2	PEC1	PEC0	TxFRST	RxFRST	Reserved

BITS	DESCRIPTIONS																
[31:8]	RESERVED	-															
[7:6]	RxTL1, RxTL0	<p>Receiver FIFO active Threshold Level control bits. These two bits are used to set the active level for the receiver FIFO interrupt. For example, if the interrupt active level is set as 4 bytes, once there are at least 4 data characters in the receiver FIFO, an interrupt is activated to notify host to read data from FIFO. Default to be 00b.</p> <table border="1"> <thead> <tr> <th>RxTL1</th> <th>RxTL0</th> <th>Rx FIFO Interrupt Active Level (Bytes)</th> </tr> </thead> <tbody> <tr> <td>0</td> <td>0</td> <td>01</td> </tr> <tr> <td>0</td> <td>1</td> <td>04</td> </tr> <tr> <td>1</td> <td>0</td> <td>08</td> </tr> <tr> <td>1</td> <td>1</td> <td>14</td> </tr> </tbody> </table>	RxTL1	RxTL0	Rx FIFO Interrupt Active Level (Bytes)	0	0	01	0	1	04	1	0	08	1	1	14
RxTL1	RxTL0	Rx FIFO Interrupt Active Level (Bytes)															
0	0	01															
0	1	04															
1	0	08															
1	1	14															

W90P710CD/W90P710CDG



Continued

BITS	DESCRIPTIONS	
[5:3]	PEC2, PEC1, PEC0	<p>Parity Error Count. Bits PEC2, PEC1 and PEC0 determine the number of allowed repetitions in reception or in transmission before setting bit PBER in SCSR. The value 000 indicates that, if only one parity error has occurred, bit PE is set; the value 111 indicate that bit PE is set after 8 parity errors.</p> <p>In protocol T =0: If a correct character is received before the programmed error number is reached, the error counter is reset If the programmed number of allowed parity errors is reached, the PBER bit in the register SCSR is set as long as the SCSR register has not been read. If a transmitted character is NAK by the card, then the smart card host interface automatically retransmits it a number of times equal to the value programmed in bits PEC2, PEC1 and PEC0 by generating an interrupt to inform the CPU to flush the transmit buffer. In transmission mode, if bits PEC2, PEC1 and PEC0 are logic 0, then the automatic retransmission is invalidated. The retransmitted character starts after the guard time. So if you set the Guard Time register to 2 and the card pulls 2 ETU's (elementary time unit) low, then there is no Guard Time. Set Guard Time =3 when T=0 in case 2 ETU's are pulled down if NAK by the card.</p> <p>In protocol T= 1: The error counter has no action; bit PE is set at the first incorrectly received character.</p>
[2]	TxFRST	<p>Transmitter FIFO Reset control bit. Setting this bit to a logical 1 resets the transmitter FIFO counter to initial state. This bit is self-cleared to 0 after being set to 1. Default is 0.</p>
[1]	RxFRST	<p>Receiver FIFO Reset control bit. Setting this bit to a logical 1 resets the receiver FIFO counter to its initial state. This bit self-clears to 0 after being set to 1. Default is 0.</p>
[0]	RESERVED	-

Smart Card Control Register (SCHL_SCCR)

REGISTER	ADDRESS	R/W	DESCRIPTION	RESET VALUE
SCHL_SCCR0	0xFFF8_500C	R/W	Smart Card Control Register 0	0x0000_0018
SCHL_SCCR1	0xFFF8_580C	R/W	Smart Card Control Register 1	0x0000_0018

W90P710CD/W90P710CDG



31	30	29	28	27	26	25	24
RESERVED							
23	22	21	20	19	18	17	16
RESERVED							
15	14	13	12	11	10	9	8
RESERVED							
7	6	5	4	3	2	1	0
BDLAB	DIR	NSBE	EPE	PROT	CPP	Reserved	Reserved

BITS	DESCRIPTIONS	
[31:8]	RESERVED	-
[7]	BDLAB	<p>Baud rate Divisor Latch Access Bit.</p> <p>When this bit is set to logical 1, software can access the baud rate divisor (in 16-bit binary format) through divisor latches (BLH and BLL) of the baud rate generator during a read/write operation. A special Smart Card ID can also be read at base address + 8 when BDLAB is 1. When this bit is set to 0, accessing base address + 0, 4 or 8, refers to RBR/TBR, IER or ISR/SCFR respectively.</p>
[6]	DIR	<p>DIRect convention</p> <p>When set to 0 or 1 receives data in the direct convention or indirect convention manner respectively. In other words, the controller will need to have this bit set to a 1 if the first byte of the ATR process is 3F (i.e. Indirect convention) and 0 if the first byte is 3B (i.e. Direct convention).</p>
[5]	NSBE	<p>Silent Byte Enable.</p> <p>Receiver detect the data byte, parity bit and stop bit are all zero</p>
[4]	EPE	<p>Even Parity Enable.</p> <p>This bit is only available when bit 3 of SCCR is programmed to 1. It prescribes the number of logical 1s in a data word including parity bit. When this bit is set to 1, an even parity is required for transmission and reception. An odd parity is demanded when this bit is set to 0.</p> <p>In contrast to its UART counterpart, Smart Card Control Register only controls parity bit setting because the data length is fixed at 8 bits for the Smart Card interface protocol.</p>
[3]	Protocol	<p>Protocol.</p> <p>Bit PROT is set if the protocol is T = 1 (asynchronous) and bit PROT = 0 if the protocol is T = 0.</p>

W90P710CD/W90P710CDG



Continued

BITS		DESCRIPTIONS
[2]	CPP	<p>Card Presence Polarity. The CPP bit can be used to choose the current card presence input polarity for different socket applications 0: Set the card presence contact input to active “high” to report card removed as active “low”. 1: Set the card presence contact input to active “low” to report card removed as active “high”.</p>
[1:0]	RESERVED	-

Smart Card Host Clock Base Register (SCHI_CBR)

REGISTER	ADDRESS	R/W	DESCRIPTION	RESET VALUE
SCHI_CBR0	0xFFF8_5010	R/W	Clock base Register 0	0x0000_000C
SCHI_CBR1	0xFFF8_5810	R/W	Clock base Register 1	0x0000_000C

31	30	29	28	27	26	25	24
RESERVED							
23	22	21	20	19	18	17	16
RESERVED							
15	14	13	12	11	10	9	8
RESERVED							
7	6	5	4	3	2	1	0
8-bit clock base Data							

BITS		DESCRIPTIONS
[31:8]	RESERVED	-
[7:0]	CBR	<p>Clock Base value. Specifies the number of internal sampling clock pulses for a data bit. Default is 0Ch. This register combines with BLH and BLL (baud rate latches) to determine the internal sampling clock frequency. For example, CBR defaults to 0Ch and BLH, BLL defaults to 1Fh, which means the SCCLK clock frequency, is 372 (12 x 31) times the internal sampling clock frequency. The default values of CBR, BLH and BLL correspond to default values of transmission factors F and D specified in ISO/IEC 7816-3. The value of 0Ch of CBR means there are 12 sampling clock pulses to detect 1 ETU (elementary time unit) data bit on the SCIO signal. It is recommended that the programmer set the CBR to be around 16 to maintain better data integrity and transmission stability.</p>



Smart Card Host Status Register (SCHL_SCSR)

REGISTER	ADDRESS	R/W	DESCRIPTION	RESET VALUE
SCHL_SCSR0	0xFFF8_5014	R	Smart card Status Register 0	0x0000_0060
SCHL_SCSR1	0xFFF8_5814	R	Smart card Status Register 1	0x0000_0060

31	30	29	28	27	26	25	24
RESERVED							
23	22	21	20	19	18	17	16
RESERVED							
15	14	13	12	11	10	9	8
RESERVED					TOF2	TOF1	TOF0
7	6	5	4	3	2	1	0
SC_RESET	TSRE	TBRE	SBD	NSER	PBER	OER	RDR

BITS	DESCRIPTIONS	
[31:11]	RESERVED	RESERVED
[10:8]	TOF2, TOF1, TOF0	<p>TOF2 is the Timeout Flag of Timer2. When Timer 2 times out, it will set the FLAG (TOF2) When host reads SCSR, it clears this bit to 0.</p> <p>TOF1 is the Timeout Flag of Timer1. When Timer 1 times out, it will set the FLAG (TOF1) When host reads SCSR, it clears this bit to 0.</p> <p>TOF0 is the Timeout Flag of Timer0. When Timer 0 times out, it will set the FLAG (TOF0) When host reads SCSR, it clears this bit to 0.</p>
[7]	SC_RESET	<p>SC_RESET pin status This bit reflects if the RESET pin is high or low.</p>
[6]	TSRE	<p>Transmitter Shift Register Empty This bit is set to 1 when the transmitter shift register is empty.</p>
[5]	TBRE	<p>Transmitter Buffer Register Empty In non-FIFO mode, this bit is set to a logical 1 when a data byte is transferred from TBR to TSR. If ETBREI of IER is a logical 1, an interrupt is generated to notify the host to write the following data bytes. In FIFO mode, this bit is set to 1 when the transmitter FIFO is empty. It is cleared to 0 when the host writes data bytes into TBR or FIFO.</p>

W90P710CD/W90P710CDG



Continued

BITS		DESCRIPTIONS
[4]	SBD	Silent Byte Detected This bit is set to 1 to indicate the received data byte is kept in the silent state for a full byte time, including start bit, data bits, parity bit, and stop bits. In FIFO mode, it indicates the same condition for the data on top of FIFO. When the host reads SCSR, it clears this bit to 0.
[3]	NSER	No Stop Bit Error This bit is set to 1 to indicate the received data has no stop bit. In FIFO mode, it indicates the same condition for the data on top of FIFO. When the host reads SCSR, it clears this bit to 0.
[2]	PBER	Parity Bit Error This bit is set to 1 to indicate that the parity bit of the received data is wrong. In FIFO mode, it indicates the same condition for the data on top of the FIFO. When host reads SCSR, it clears this bit to 0.
[1]	OER	Overrun Error This bit is set to 1 to indicate the previously received data is overwritten by the next received data before it is read by the host. In FIFO mode, it indicates the same condition instead of FIFO full. When the host reads SCSR, it clears this bit to 0.
[0]	RDR	Receiver Data Ready This bit is set to 1 to indicate the received data is ready to be read by the host in RBR or FIFO. If no data are left in RBR or FIFO, the bit is cleared to 0.

Smart Card Host Guard Time Register (SCHI_GTR)

REGISTER	ADDRESS	R/W	DESCRIPTION	RESET VALUE
SCHI_GTR0	0xFFF8_5018	R/W	Guard Time Register 0	0x0000_0001
SCHI_GTR1	0xFFF8_5818	R/W	Guard Time Register 1	0x0000_0001

31	30	29	28	27	26	25	24
RESERVED							
23	22	21	20	19	18	17	16
RESERVED							
15	14	13	12	11	10	9	8
RESERVED							
7	6	5	4	3	2	1	0
GTR [7:0]							

W90P710CD/W90P710CDG



BITS	DESCRIPTIONS	
[31:8]	RESERVED	-
[7:0]	GTR	<p>Guard Time Register value. This register specifies number of stop bits appended to the end of a data byte. Bit 7 ~ 0: Guard Time values. Default to be 01h.</p>

Smart Card Host Extended Control Register (SCHI_ECR)

REGISTER	ADDRESS	R/W	DESCRIPTION	RESET VALUE
SCHI_ECR0	0xFFF8_501C	R/W	Extended Control Register 0	0x0000_0052
SCHI_ECR1	0xFFF8_581C	R/W	Extended Control Register 1	0x0000_0052

31	30	29	28	27	26	25	24
RESERVED							
23	22	21	20	19	18	17	16
RESERVED							
15	14	13	12	11	10	9	8
RESERVED					PSCKFS2	PSCKFS1	PSCKFS0
7	6	5	4	3	2	1	0
Reserved	SCKFS2	SCKFS1	SCKFS0	CLKSTP	CLKSTPL	Reserved	

BITS	DESCRIPTIONS																	
[31:11]	RESERVED	-																
[10:8]	PSCKFS2, PSCKFS1, PSCKFS0	<p>PSCK Frequency Selection Bit 2, 1 and 0. This selection can adjust power-on /power-off sequence interval. They select working clock frequency as following table. Default values are 05h.</p> <table border="1" style="margin-left: auto; margin-right: auto;"> <thead> <tr> <th>SCKFS0, SCKFS1, SCKFS2</th> <th>SCCLK frequency</th> </tr> </thead> <tbody> <tr> <td>000</td> <td>80MHz</td> </tr> <tr> <td>001</td> <td>40 MHz</td> </tr> <tr> <td>010</td> <td>20 MHz</td> </tr> <tr> <td>011</td> <td>10 MHz</td> </tr> <tr> <td>100</td> <td>5 MHz</td> </tr> <tr> <td>101</td> <td>2.5 MHz</td> </tr> <tr> <td>110</td> <td>1.25 MHz</td> </tr> </tbody> </table>	SCKFS0, SCKFS1, SCKFS2	SCCLK frequency	000	80MHz	001	40 MHz	010	20 MHz	011	10 MHz	100	5 MHz	101	2.5 MHz	110	1.25 MHz
SCKFS0, SCKFS1, SCKFS2	SCCLK frequency																	
000	80MHz																	
001	40 MHz																	
010	20 MHz																	
011	10 MHz																	
100	5 MHz																	
101	2.5 MHz																	
110	1.25 MHz																	



Continued

BITS	DESCRIPTIONS																	
[6:4]	SCKFS2, SCKFS1, SCKFS0	<p>SCCLK Frequency Selection Bit 2, 1 and 0. The working clock frequency selection is as follows. Default values are 05h.</p> <table border="1" data-bbox="699 506 1263 842"> <thead> <tr> <th>SCKFS0, SCKFS1, SCKFS2</th> <th>SCCLK frequency</th> </tr> </thead> <tbody> <tr> <td>000</td> <td>80MHz</td> </tr> <tr> <td>001</td> <td>40 MHz</td> </tr> <tr> <td>010</td> <td>20 MHz</td> </tr> <tr> <td>011</td> <td>10 MHz</td> </tr> <tr> <td>100</td> <td>5 MHz</td> </tr> <tr> <td>101</td> <td>2.5 MHz</td> </tr> <tr> <td>110</td> <td>1.25 MHz</td> </tr> </tbody> </table>	SCKFS0, SCKFS1, SCKFS2	SCCLK frequency	000	80MHz	001	40 MHz	010	20 MHz	011	10 MHz	100	5 MHz	101	2.5 MHz	110	1.25 MHz
SCKFS0, SCKFS1, SCKFS2	SCCLK frequency																	
000	80MHz																	
001	40 MHz																	
010	20 MHz																	
011	10 MHz																	
100	5 MHz																	
101	2.5 MHz																	
110	1.25 MHz																	
[3]	CLKSTPL	<p>Clock Stop Voltage Level 0 = SCCLK stops at low if CLKSTP is also set to 0. 1 = SCCLK stops at high if CLKSTP is also set to 1.</p>																
[2]	CLKSTP	<p>Clock Stop Control Bit Setting 1 to this bit stops SCCLK at a voltage level specified by CLKSTPL (bit 3 of ECR).</p>																
[1:0]	RESERVED	-																

Smart Card Host Test Mode Register (SCHI_TMR)

REGISTER	ADDRESS	R/W	DESCRIPTION	RESET VALUE
SCHI_TMR0	0xFFF8_5020	R/W	Test mode Register 0	0x0000_0000
SCHI_TMR1	0xFFF8_5820	R/W	Test mode Register 1	0x0000_0000

This 8-bit register is added in order to allow better testing of the Smart Card host. Currently only bit 1 is used. In the future, other bits can be used to program the host and improve the testing platform.

W90P710CD/W90P710CDG



31	30	29	28	27	26	25	24
RESERVED							
23	22	21	20	19	18	17	16
RESERVED							
15	14	13	12	11	10	9	8
RESERVED							
7	6	5	4	3	2	1	0
RESERVED						SCRST_L	POWER_S EQ_SKIP

BITS	DESCRIPTIONS	
[31:2]	RESERVED	-
[1]	SCRST_L	<p>Smart Card Reset Pin Control Bit</p> <p>The software driver control's this bit directly, which in turn determines the SCRST_L signal to the Smart Card. 0 or 1 on this pin drives 0 or 1 respectively on the SCRST_L signal. This feature was first added to allow the SCRST_L to be pulled high at a quicker rate during the reset phase to improve testing. However, upon attempting to further improve the capability of the Smart Card host, it was found that this bit holds the key to solving one of the major problems with this design.</p> <p>Originally, the SCRST_L signal is automatically pulled high after a fixed period of time (via the use of a hardware counter) when the card is inserted. However, there have been many cases where this signal is pulled high even before power is supplied to the card, which is a clear violation of the ISO 7816 specification. This as a result causes an invalid ATR to be read by the host during the initial insertion of the card. Earlier versions of this IP rectified this problem by having the software ignore the invalid ATR during the initial insertion and performing either a warm or cold setup to capture the true ATR on its second attempt.</p> <p>This bit allows a lot of flexibility to fix the problem mentioned above. The software driver now has the ability to determine when the SCRST_L is to be pulled either high or low, avoiding the problems of earlier versions. With this modification, software ensures that the SCRST_L signal is pulled high only after power is supplied to the card, thus allowing the true ATR to always be read during the initial insertion of the card.</p>
[0]	POWER_SE Q_SKIP	<p>When this bit is low, power_on/off_seq operation is normal</p> <p>Set this bit high to skip the power_on/off_seq to speed-up S/W simulation</p>

Smart Card Host Timeout configuration Register (SCHI_TOC)

REGISTER	ADDRESS	R/W	DESCRIPTION	RESET VALUE
SCHI_TOC0	0xFFF8_5028	R/W	Timeout Configuration Register 0	0x0000_0000
SCHI_TOC1	0xFFF8_5828	R/W	Timeout Configuration Register 1	0x0000_0000

31	30	29	28	27	26	25	24
RESERVED							
23	22	21	20	19	18	17	16
RESERVED							
15	14	13	12	11	10	9	8
RESERVED				nDBGACK_EN2	TOC8	TOC7	TOC6
7	6	5	4	3	2	1	0
nDBGACK_EN1	TOC5	TOC4	TOC3	nDBGACK_EN0	TOC2	TOC1	TOC0

BITS	DESCRIPTIONS	
[31:12]	RESERVED	-
[11]	nDBGACK_EN2	ICE Debug mode Acknowledge enable for Timer 2 0 = When DBGACK is high, the timer clock is held 1 = Whether DBGACK is high or not, the timer clock is not held.



Continued

BITS	DESCRIPTIONS		
[10:8]	TOC8, TOC7, TOC6	TOC8, TOC7, TOC6 (Timeout Configuration) control 24-bit timer 2 configuration.	
		TOC8, TOC7, TOC6 value	OPERATION MODE
		000	24-bit counter 2 is stopped
		001	Counting using the value stored in register TOIR 2 is started after 001b is written to the TOC register. An interrupt is triggered if enabled, and bit TO2 is set within the SCSR register when the terminal count is reached. The counter is stopped by writing 000b to the TOC register, and should be stopped before reloading new values.
		010	Counter 2 starts counting the content of register TOIR2 on the first START bit (reception or transmission) detected on the pin I/O after 010b is written in register TOC. When counter 2 reaches its terminal count, an interrupt is triggered if enable. Bit TO2 in register SCSR is set. The counter is reloaded with TOIR2 and starts counting on each subsequent START bit. It is possible to change the content of TOIR2 during a count; the current count is not affected and the new count value is taken into account at the next START bit. The count is stopped by writing 000b to register TOC,
		011	Counter 2 starts counting the content of register TOIR2 on the first START bit (reception or transmission) detected on the pin I/O after 010b is written in register TOC. When counter 2 reaches its terminal count, an interrupt is triggered if enabled. Bit TO2 in register SCSR is set. The count is stopped by writing 000b in register TOC,
100	Same as value 000b, except that counter 2 is stopped at the end of the 12 th ETU following the first START bit detected after 100b has been written to register TOC		
[7]	nDBGACK_EN1	ICE Debug mode Acknowledge enable for Timer 1 0 = When DBGACK is high, the timer clock is held 1= Whether DBGACK is high or not, the timer clock is not held	



Continued

BITS	DESCRIPTIONS													
<p>[6:4]</p> <p>TOC5, TOC4, TOC3</p>		<p>TOC5, TOC4, TOC3 (Timeout Configuration) control 16-bit timer 1 configuration.</p> <table border="1" data-bbox="581 527 1393 1528"> <thead> <tr> <th data-bbox="581 527 678 663">TOC5, TOC4, TOC3 value</th> <th data-bbox="678 527 1393 663">OPERATION MODE</th> </tr> </thead> <tbody> <tr> <td data-bbox="581 663 678 699">000</td> <td data-bbox="678 663 1393 699">16-bit counter 1 is stopped</td> </tr> <tr> <td data-bbox="581 699 678 894">001</td> <td data-bbox="678 699 1393 894">Counting the value stored in register TOIR 1 is started after 001b is written to register TOC. An interrupt is triggered if enabled, and bit TO1 is set within register SCSR when the terminal count is reached. The counter is stopped by writing 000b to register TOC, and should be stopped before reloading new values in register TOC.</td> </tr> <tr> <td data-bbox="581 894 678 1234">010</td> <td data-bbox="678 894 1393 1234">Counter 1 starts counting the contents of register TOIR1 on the first START bit (reception or transmission) detected on the pin I/O after 010b is written to register TOC. When counter 1 reaches its terminal count, an interrupt is triggered if enabled. Bit TO1 in register SCSR is set. The counter is reloaded with TOIR1 and starts counting on each subsequent START bit. It is possible to change the content of TOIR1 during a count; the current count is not affected and the new count value is taken into account at the next START bit. The count is stopped by writing 000b to register TOC,</td> </tr> <tr> <td data-bbox="581 1234 678 1423">011</td> <td data-bbox="678 1234 1393 1423">Counter 1 starts counting the content of register TOIR1 on the first START bit (reception or transmission) detected on the pin I/O after 010b is written to register TOC. When counter 1 reaches its terminal count, an interrupt is triggered if enabled. Bit TO1 in register SCSR is set. The count is stopped by writing 000b to register TOC,</td> </tr> <tr> <td data-bbox="581 1423 678 1528">100</td> <td data-bbox="678 1423 1393 1528">Same as value 000b, except that counter 1 is stopped at the end of the 12th ETU following the first START bit detected after 100b has been written to register TOC</td> </tr> </tbody> </table>	TOC5, TOC4, TOC3 value	OPERATION MODE	000	16-bit counter 1 is stopped	001	Counting the value stored in register TOIR 1 is started after 001b is written to register TOC. An interrupt is triggered if enabled, and bit TO1 is set within register SCSR when the terminal count is reached. The counter is stopped by writing 000b to register TOC, and should be stopped before reloading new values in register TOC.	010	Counter 1 starts counting the contents of register TOIR1 on the first START bit (reception or transmission) detected on the pin I/O after 010b is written to register TOC. When counter 1 reaches its terminal count, an interrupt is triggered if enabled. Bit TO1 in register SCSR is set. The counter is reloaded with TOIR1 and starts counting on each subsequent START bit. It is possible to change the content of TOIR1 during a count; the current count is not affected and the new count value is taken into account at the next START bit. The count is stopped by writing 000b to register TOC,	011	Counter 1 starts counting the content of register TOIR1 on the first START bit (reception or transmission) detected on the pin I/O after 010b is written to register TOC. When counter 1 reaches its terminal count, an interrupt is triggered if enabled. Bit TO1 in register SCSR is set. The count is stopped by writing 000b to register TOC,	100	Same as value 000b, except that counter 1 is stopped at the end of the 12 th ETU following the first START bit detected after 100b has been written to register TOC
		TOC5, TOC4, TOC3 value	OPERATION MODE											
000	16-bit counter 1 is stopped													
001	Counting the value stored in register TOIR 1 is started after 001b is written to register TOC. An interrupt is triggered if enabled, and bit TO1 is set within register SCSR when the terminal count is reached. The counter is stopped by writing 000b to register TOC, and should be stopped before reloading new values in register TOC.													
010	Counter 1 starts counting the contents of register TOIR1 on the first START bit (reception or transmission) detected on the pin I/O after 010b is written to register TOC. When counter 1 reaches its terminal count, an interrupt is triggered if enabled. Bit TO1 in register SCSR is set. The counter is reloaded with TOIR1 and starts counting on each subsequent START bit. It is possible to change the content of TOIR1 during a count; the current count is not affected and the new count value is taken into account at the next START bit. The count is stopped by writing 000b to register TOC,													
011	Counter 1 starts counting the content of register TOIR1 on the first START bit (reception or transmission) detected on the pin I/O after 010b is written to register TOC. When counter 1 reaches its terminal count, an interrupt is triggered if enabled. Bit TO1 in register SCSR is set. The count is stopped by writing 000b to register TOC,													
100	Same as value 000b, except that counter 1 is stopped at the end of the 12 th ETU following the first START bit detected after 100b has been written to register TOC													
<p>[3]</p>	<p>nDBGACK_EN0</p>	<p>ICE Debug mode Acknowledge enabled for Timer 0</p> <p>0 = When DBGACK is high, the timer clock is held</p> <p>1 = Whether DBGACK is high or not, the timer clock is not held</p>												



Continued

BITS	DESCRIPTIONS														
[2:0]	TOC2, TOC1, TOC0	<p>TOC5, TOC4, TOC3 (Time Out Configuration) control 8-bit timer 0 configuration.</p>													
		<table border="1"> <thead> <tr> <th data-bbox="581 548 695 695">TOC2, TOC1, TOC0 value</th> <th data-bbox="695 548 1385 695">OPERATION MODE</th> </tr> </thead> <tbody> <tr> <td data-bbox="581 695 695 730">000</td> <td data-bbox="695 695 1385 730">8-bit counter 0 is stopped</td> </tr> <tr> <td data-bbox="581 730 695 926">001</td> <td data-bbox="695 730 1385 926">Counting the value stored in register TOIR 0 is started after 001b is written to register TOC. An interrupt is triggered if enabled, and bit TO0 set within register SCSR when the terminal count is reached. The counter is stopped by writing 000b to register TOC, and should be stopped before reloading new values to register TOC.</td> </tr> <tr> <td data-bbox="581 926 695 1268">010</td> <td data-bbox="695 926 1385 1268">Counter 0 starts counting the contents of register TOIR0 on the first START bit (reception or transmission) detected on the pin I/O after 010b is written to register TOC. When counter 0 reaches its terminal count, an interrupt is triggered if enabled. Bit TO0 in register SCSR is set. The counter is reloaded with TOIR0 and starts counting on each subsequent START bit. It is possible to change the content of TOIR0 during a count; the current count is not affected and the new count value is taken into account at the next START bit. The count is stopped by writing 000b to register TOC,</td> </tr> <tr> <td data-bbox="581 1268 695 1463">011</td> <td data-bbox="695 1268 1385 1463">Counter 0 starts counting the contents of register TOIR0 on the first START bit (reception or transmission) detected on the pin I/O after 010b is written to register TOC. When counter 0 reaches its terminal count, an interrupt is triggered if enabled. Bit TO0 in register SCSR is set. The count is stopped by writing 000b to register TOC,</td> </tr> <tr> <td data-bbox="581 1463 695 1604">100</td> <td data-bbox="695 1463 1385 1604">Same as value 000b, except that counter 0 is stopped at the end of the 12th ETU following the first START bit detected after 100b has been written to register TOC</td> </tr> </tbody> </table>		TOC2, TOC1, TOC0 value	OPERATION MODE	000	8-bit counter 0 is stopped	001	Counting the value stored in register TOIR 0 is started after 001b is written to register TOC. An interrupt is triggered if enabled, and bit TO0 set within register SCSR when the terminal count is reached. The counter is stopped by writing 000b to register TOC, and should be stopped before reloading new values to register TOC.	010	Counter 0 starts counting the contents of register TOIR0 on the first START bit (reception or transmission) detected on the pin I/O after 010b is written to register TOC. When counter 0 reaches its terminal count, an interrupt is triggered if enabled. Bit TO0 in register SCSR is set. The counter is reloaded with TOIR0 and starts counting on each subsequent START bit. It is possible to change the content of TOIR0 during a count; the current count is not affected and the new count value is taken into account at the next START bit. The count is stopped by writing 000b to register TOC,	011	Counter 0 starts counting the contents of register TOIR0 on the first START bit (reception or transmission) detected on the pin I/O after 010b is written to register TOC. When counter 0 reaches its terminal count, an interrupt is triggered if enabled. Bit TO0 in register SCSR is set. The count is stopped by writing 000b to register TOC,	100	Same as value 000b, except that counter 0 is stopped at the end of the 12 th ETU following the first START bit detected after 100b has been written to register TOC
		TOC2, TOC1, TOC0 value	OPERATION MODE												
		000	8-bit counter 0 is stopped												
		001	Counting the value stored in register TOIR 0 is started after 001b is written to register TOC. An interrupt is triggered if enabled, and bit TO0 set within register SCSR when the terminal count is reached. The counter is stopped by writing 000b to register TOC, and should be stopped before reloading new values to register TOC.												
		010	Counter 0 starts counting the contents of register TOIR0 on the first START bit (reception or transmission) detected on the pin I/O after 010b is written to register TOC. When counter 0 reaches its terminal count, an interrupt is triggered if enabled. Bit TO0 in register SCSR is set. The counter is reloaded with TOIR0 and starts counting on each subsequent START bit. It is possible to change the content of TOIR0 during a count; the current count is not affected and the new count value is taken into account at the next START bit. The count is stopped by writing 000b to register TOC,												
		011	Counter 0 starts counting the contents of register TOIR0 on the first START bit (reception or transmission) detected on the pin I/O after 010b is written to register TOC. When counter 0 reaches its terminal count, an interrupt is triggered if enabled. Bit TO0 in register SCSR is set. The count is stopped by writing 000b to register TOC,												
100	Same as value 000b, except that counter 0 is stopped at the end of the 12 th ETU following the first START bit detected after 100b has been written to register TOC														

Smart Card Host Time-out Initial Register 0 (SCHI_TOIR 0)

REGISTER	ADDRESS	R/W	DESCRIPTION	RESET VALUE
SCHI_TOIR0_0	0xFFFF8_502C	R/W	8-bit Timeout initial Register 0	0x0000_0000
SCHI_TOIR0_1	0xFFFF8_582C	R/W	8-bit Timeout initial Register 1	0x0000_0000

31	30	29	28	27	26	25	24
RESERVED							
23	22	21	20	19	18	17	16
RESERVED							
15	14	13	12	11	10	9	8
RESERVED							
7	6	5	4	3	2	1	0
TOIR0[7:0]							

BITS	DESCRIPTIONS	
[31:8]	RESERVED	-
[7:0]	TOIR0	8-bit Timeout Initial Register 0 The value to load in register TOIR 0 is the number of ETU's to count. The timers may only be used when a card is active with a running clock. This 8-bit timeout initial register is used to preload the value for each count.

Smart Card Host Time-out Initial Register 1 (SCHI_TOIR 1)

REGISTER	ADDRESS	R/W	DESCRIPTION	RESET VALUE
SCHI_TOIR1_0	0xFFFF8_5030	R/W	16 bit Time out initial Register 0	0x0000_0000
SCHI_TOIR1_1	0xFFFF8_5830	R/W	16 bit Time out initial Register 1	0x0000_0000

31	30	29	28	27	26	25	24
RESERVED							
23	22	21	20	19	18	17	16
RESERVED							
15	14	13	12	11	10	9	8
TOIR1 [15:8]							
7	6	5	4	3	2	1	0
TOIR1 [7:0]							



BITS	DESCRIPTIONS	
[31:16]	RESERVED	-
[15:0]	TOIR1	16-bit Timeout Initial Register 1 The value to load in register TOIR 1 is the number of ETU's to count. The timers may only be used when a card is active with a running clock. This 16-bit timeout initial register used to preload the value for each count.

Smart Card Host Time-out Initial Register 2 (SCHI_TOIR 2)

REGISTER	ADDRESS	R/W	DESCRIPTION	RESET VALUE
SCHI_TOIR2_0	0xFFF8_5034	R/W	24-bit Timeout initial Register 0	0x0000_0000
SCHI_TOIR2_1	0xFFF8_5834	R/W	24-bit Timeout initial Register 1	0x0000_0000

31	30	29	28	27	26	25	24
RESERVED							
23	22	21	20	19	18	17	16
TOIR2[23:16]							
15	14	13	12	11	10	9	8
TOIR2[15:8]							
7	6	5	4	3	2	1	0
TOIR2[7:0]							

BITS	DESCRIPTIONS	
[31:24]	RESERVED	-
[23:0]	TOIR2	24-bit Timeout Initial Register 2 The value to load register TOIR 2 is the number of ETU's to count. The timers may only be used when a card is active with a running clock. This 24-bit timeout initial register used to preload the value for each count.

Smart Card Host Time-Out Data Register 0 (SCHI_TODR0)

REGISTER	ADDRESS	R/W	DESCRIPTION	RESET VALUE
SCHI_TOD0_0	0xFFF8_5038	R	8-bit Timeout data Register 0	0x0000_00FF
SCHI_TOD0_1	0xFFF8_5838	R	8-bit Timeout data Register 1	0x0000_00FF

W90P710CD/W90P710CDG



31	30	29	28	27	26	25	24
RESERVED							
23	22	21	20	19	18	17	16
RESERVED							
15	14	13	12	11	10	9	8
RESERVED							
7	6	5	4	3	2	1	0
TOD0[7:0]							

BITS	DESCRIPTIONS	
[31:8]	RESERVED	-
[7:0]	TOD0	<p>8 bit Timeout Data Count Register 0</p> <p>The value shown in register TOD 0 is the number of ETU's to count. The timeout data counters may only be used when a card is active with a running clock. This 8-bit timeout data register used to show the current counting value.</p>

Smart Card Host Time-Out Data Register 1 (SCHI_TODR1)

REGISTER	ADDRESS	R/W	DESCRIPTION	RESET VALUE
SCHI_TOD1_0	0xFFF8_503C	R	16 bit Timeout Data Register 0	0x0000_00FF
SCHI_TOD1_1	0xFFF8_583C	R	16 bit Timeout Data Register 1	0x0000_00FF

31	30	29	28	27	26	25	24
RESERVED							
23	22	21	20	19	18	17	16
RESERVED							
15	14	13	12	11	10	9	8
TOD1[15:8]							
7	6	5	4	3	2	1	0
TDO1[7:0]							

BITS	DESCRIPTIONS	
[31:16]	RESERVED	-
[15:0]	TOD1	<p>16 bit Timeout Data Count Register 1</p> <p>The value shown in register TOD 1 is the number of ETU's to count. The timeout data counters may only be used when a card is active with a running clock. This 16-bit timeout data register used to show the current counting value.</p>

W90P710CD/W90P710CDG



Smart Card Host Time-Out Data Register 2 (SCHI_TODR2)

REGISTER	ADDRESS	R/W	DESCRIPTION	RESET VALUE
SCHI_TOD2_0	0xFFF8_5040	R	24 bit Timeout Data Register 0	0x0000_00FF
SCHI_TOD2_1	0xFFF8_5840	R	24 bit Timeout Data Register 1	0x0000_00FF

31	30	29	28	27	26	25	24
RESERVED							
23	22	21	20	19	18	17	16
TOD2[23:16]							
15	14	13	12	11	10	9	8
TOD2[15:8]							
7	6	5	4	3	2	1	0
TDO2[7:0]							

BITS	DESCRIPTIONS	
[31:24]	RESERVED	-
[23:0]	TOR2	<p>24 bit Timeout Data Count Register 2</p> <p>The value to load in register TOD 2 is the number of ETU's to count. The timers may only be used when a card is active with a running clock. This 24-bit timeout data register is used to show the current counting value.</p>

Smart Card Host Buffer Timeout Data Register (SCHI_BTOR)

REGISTER	ADDRESS	R/W	DESCRIPTION	RESET VALUE
SCHI_BTOR0	0xFFF8_5044	R/W	Buffer Timeout Data Register 0	0x0000_0000
SCHI_BTOR1	0xFFF8_5844	R/W	Buffer Timeout Data Register 1	0x0000_0000

31	30	29	28	27	26	25	24
RESERVED							
23	22	21	20	19	18	17	16
RESERVED							
15	14	13	12	11	10	9	8
RESERVED							
7	6	5	4	3	2	1	0
BTOIE	BTOIC_6	BTOIC_5	BTOIC_4	BTOIC_3	BTOIC_2	BTOIC_1	BTOIC_0



BITS	DESCRIPTIONS	
[31:8]	RESERVED	-
[7]	BTOIE	Buffer Timeout Interrupt Enable The feature of receiver buffer timeout interrupt is enabled only when BTOIE[7] = ERDRI = 1 .
[6:0]	BTOIC	Buffer Timeout Interrupt Comparator The timeout counter resets and starts counting (the counter = ETU) whenever the RX FIFO receives a new data word. Once the content of the timeout counter (TOUT_CNT) is equal to that of time out interrupt comparator (TOIC), a receiver timeout interrupt (lrpt_TOUT) is generated if TOR[7] = ERDRI = 1. A new incoming data word or BRX FIFO empty clear lrpt_TOUT.

Smart Card Host Baud Rate Divider Latch Lower Byte (SCHL_BLL)

REGISTER	ADDRESS	R/W	DESCRIPTION	RESET VALUE
SCHI_BLL0	0XFFF8_5000 (DLAB = 1)	R/W	Baud rate divisor Latch Lower byte Register 0	0x0000_001F
SCHI_BLL1	0XFFF8_5800 (DLAB = 1)	R/W	Baud rate divisor Latch Lower byte Register 1	0x0000_001F

31	30	29	28	27	26	25	24
RESERVED							
23	22	21	20	19	18	17	16
RESERVED							
15	14	13	12	11	10	9	8
RESERVED							
7	6	5	4	3	2	1	0
BLL[7:0]							

BITS	DESCRIPTIONS	
[31:8]	RESERVED	-
[7:0]	BLL	8 bit Baud Rate Divider Latch Low Byte Register This register combined with BLH and CBR determines the internal sampling clock frequency. Bit 7 ~ 0: Baud rate divisor latch lower byte values. Defaults to 1Fh.

W90P710CD/W90P710CDG



Baud Rate Divider Latch Higher Byte (SCHI_BLH)

REGISTER	ADDRESS	R/W	DESCRIPTION	RESET VALUE
SCHI_BLH0	0XFFF8_5004 (DLAB = 1)	R/W	Baud rate divisor Latch Higher byte Register 0	0x0000_0000
SCHI_BLH1	0XFFF8_5804 (DLAB = 1)	R/W	Baud rate divisor Latch Higher byte Register 1	0x0000_0000

31	30	29	28	27	26	25	24
RESERVED							
23	22	21	20	19	18	17	16
RESERVED							
15	14	13	12	11	10	9	8
RESERVED							
7	6	5	4	3	2	1	0
BLH[7:0]							

BITS	DESCRIPTIONS	
[31:8]	RESERVED	-
[7:0]	BLH	<p>8 bit Baud rate divider Latch High byte register</p> <p>This register combined with BLL and CBR determines the internal sampling clock frequency.</p> <p>Bit 7 ~ 0: Baud rate divisor latch higher byte values. Default to be 00h.</p>

SMART CARD ID NUMBER (SCHI_ID)

REGISTER	ADDRESS	R/W	DESCRIPTION	RESET VALUE
SCHI_ID0	0XFFF8_5008 (DLAB = 1)	R	Smart card ID number Register 0	0x0000_0070
SCHI_ID1	0XFFF8_5808 (DLAB = 1)	R	Smart card ID number Register 1	0x0000_0070

W90P710CD/W90P710CDG



31	30	29	28	27	26	25	24
RESERVED							
23	22	21	20	19	18	17	16
RESERVED							
15	14	13	12	11	10	9	8
RESERVED							
7	6	5	4	3	2	1	0
ID[7:0]							

BITS	DESCRIPTIONS	
[31:8]	RESERVED	-
[7:0]	ID	8-bit smart card ID number register This register contains a specific value of 70h for the driver to identify the Smart Card interface.



6.17.3 Functional description

The following description uses abbreviations to refer to control/status registers and their contents of the Smart Card interface as seen in section 7.12.2

● Initialization

User needs to program control registers so that ATR (Answer To Reset) data streams can be properly decoded after card insertion. Initialization settings include the following steps where sequential order is irrelevant.

1. BLH, BLL and CBR are written with 00h, 1Fh and 0Ch respectively to comply with default transmission factors Fd and Dd, which are 372 and 1 as specified in ISO/IEC 7816-3.
2. GTR is programmed with 01h for one stop bit.
3. Set SCFR bit 1 to 1 to reset receiver FIFO.
4. Set EPE bit in SCCR bit 4 to be 1 for EVEN parity, set EPE bit to be 0 for odd parity.
5. Set SCKFS1 and SCKFS0 to "05" to select 2.5 MHz for SCCLK on 80MHz system clock.

Most default values of above control bits are designed as specified in initialization step but it is recommended that the user perform the entire initialization sequence to avoid any ambiguity.

The relationship between transmission factors and settings of BLH, BLL and CBR is best described in the following example.

$$1etu = \frac{F}{D} \times \frac{1}{f} \quad (\text{f means SCCLK frequency})$$

Therefore,

$$\frac{Fd}{Dd} = \frac{372}{1} = (\text{BLH, BLL}) \times \text{CBR} = 31 \times 12$$

● Activation

Card insertion pulls up SCn_PRES (assuming SCPSNT in ISR bit 5 is active high) and in consequence SCn_PWR is pulled down to activate power MOS to supply power to the card slot after a delay of about 5 ms. This delay is for the card slot mechanism to settle down before power is actually applied.

SCn_CLK starts to output right after SCn_PWR is active while SCIO is in reception mode and pulled up externally. SCn_RST keeps low initially to reset the card but will output high after 512 clock cycles to meet requirement of tb of more than 400 clock cycles (specified in ISO/IEC 7816-3).

To meet another timing requirement, tc of ISO/IEC 7816-3, a counter based on SCn_CLK is implemented to start counting on the rising edge of SCn_RST. SCn_PWR is deactivated if no ATR (Answer To Reset) is detected after 65536 clock cycles from the rising edge of SCn_RST.

● Answer-to-Reset

Answer-to-Reset (ATR) is the data streams sent by the card to the interface as an answer to a reset on SCn_RST signal. Refer to ISO/IEC 7816-3 for a detailed description of ATR.

There are two kinds of cards specified in ISO/IEC 7816-3, inverse convention card and direct convention card. Although these two conventions treat logical meanings (0 or 1) of voltage levels (low or high) differently, Winbond's implementation of the Smart Card interface decodes a high voltage level data bit as 1 and low voltage level data bit as 0, and resorts to software to interpret incoming



data. The software driver needs to interpret the initial ATR character first to determine which convention to use for the inserted card and chooses a conversion procedure for it. Subsequent incoming data bytes must be passed through a conversion procedure before actually transferring these data bytes to the host. A similar conversion procedure must be applied to outgoing data bytes before writing to TBR as well.

For example, the raw data byte for the initial character of inverse-convention ATR would be 3Fh. The software driver therefore needs a conversion procedure to reverse the bit-significance and polarity to process subsequent raw data bytes. On the other hand, the initial character of the direct-convention ATR is 3Bh, which needs no conversion procedure to process the data byte.

● Data transfer

Software driver might need to configure control registers again based on information contained in ATR before processing subsequent data transfers. The following guidelines are provided for programming reference.

1. EPE should be set to 1 for direct-convention card and otherwise for inverse-convention card.
2. BLH, BLL and CBR should be set to comply with Fi and Di.
3. GTR is used for various stop bit requirements of different transmission protocols.
4. Use the interrupt resources to control the communication sequence.
5. Monitor SCSR for transmission integrity.

● Cold reset and warm reset

Cold reset is achieved by writing a 1 to PWRDN (bit 7 of IER). It deactivates SCn_PWR to high. Consequentially, SCn_RST is pulled down and SCCLK is stopped. User must write a 0 to PWRDN (bit 7 of IER) to resume Smart Card interface to a normal activation state assuming card is still present. The activation sequence and deactivation sequence are done by internal F.S.M

When in a normal activation state, writing a 0 SCRST_L (bit 1 of TMR) will force SCn_RST pin to low triggering a warm reset. Its effect is similar to a cold reset except that SCn_PWR is kept activated and therefore the power supply to the card stays on.

● Power states

SCHI employs a sophisticated algorithm to partition the Smart Card interface's internal circuits to achieve optimal power utilization. However, users must take extra care in the design of application circuits following guidelines stated below to prevent potential signal conflict and unnecessary power consumption.

There are three power states: disabled state, active state, and power down state. The disabled state is the default state when power is first applied to the IC. SCPWD (Smart Card Power Down) controls whether in an active state (SCPWD = 0) or in the power down state (SCPWD = 1).

● Disabled state

Smart Card interface is initially disabled. The clock is idle in this state, and therefore this is the least power-consuming state. To prevent current leakage from floating connections, it is designed to output a predetermined voltage level on all the I/O pins of the Smart Card interface, as follows:

SCn_PWR outputs high to disable power supply to socket;

W90P710CD/W90P710CDG



SCn_RST, SCn_CLK, and SCn_DAT output low;
SCPSNT is tri-stated.

These I/O conditions also apply to sockets in the power down state (SCPWD = 1) or deselected socket in the idle state. Designers of application circuits must take extra care so that no contention occurs when Smart Card interface is in any power-saving state.

● **Active state**

Active state is when Smart Card interface is actually performing some function: configuring of control and interrupt registers, detecting card insertion/extraction, receiving ATR (Answer To Reset) information and communications packets from the host. Refer to section 7.12.3 for detailed function descriptions.

This is the most power-consuming state, and actual power consumption is dependent on interface traffic.

● **Power down state**

Transition from an active state to the power down state is accomplished by setting SCPWD to 1. The clock is stopped for most internal core circuits except the detection circuit for SCPSNT toggle (card insertion/extraction). SCPSNT toggle can interrupt CPU and through this feature, the Smart Card interface in power down state can be woken up by card insertion/extraction. The programmer may also directly write a 0 to SCPWD to wake up the Smart Card interface.

Smart Card interface spends a little bit more power to maintain SCPSNT toggle detection circuit in the power down state than in the disabled state which saves even more power than the active state by stopping clock for the core circuit.

Programmers must ensure that all on-going transactions are concluded before putting the Smart Card interface into the power down state to prevent potential disoperation of the internal state machine.



6.18 I²C Interface

I²C is a two-wire, bi-directional serial bus that provides a simple and efficient method of data exchange between devices. The I²C standard is a true multi-master bus including collision detection and arbitration that prevents data corruption if two or more masters attempt to control the bus simultaneously.

Serial, 8-bit oriented bi-directional data transfers can be made up to 100 kbit/s in Standard-mode, up to 400 kbit/s in Fast-mode, or up to 3.4 Mbit/s in High-speed mode. Only 100kbps and 400kbps modes are supported directly. For High-speed mode special IOs are needed. If these IOs are available and used, then High-speed mode is also supported.

Data is transferred between a Master and a Slave synchronously to SCL on the SDA line on a **byte-by-byte** basis. Each data byte is 8 bits long. There is one SCL clock pulse for each data bit with the **MSB being transmitted first**. An acknowledge bit follows each transferred byte. Each bit is sampled during the high period of SCL; and therefore, the SDA line may be changed only during the low period of SCL and must be held stable during the high period of SCL. A transition on the SDA line while SCL is high is interpreted as a command (START or STOP).

The I²C Master Core includes the following features:

- AMBA APB interface compatible
- Compatible with Philips I²C standard, supports master mode
- Multi Master Operation
- Clock stretching and wait state generation
- Provide multi-byte transmit operation, up to 4 bytes can be transmitted in a single transfer
- Software programmable acknowledge bit
- Arbitration lost interrupt, with automatic transfer cancellation
- Start/Stop/Repeated Start/Acknowledge generation
- Start/Stop/Repeated Start detection
- Bus busy detection
- Supports 7 bit addressing mode
- Fully static synchronous design with one clock domain
- Software mode I²C



6.18.1 I²C Protocol

Normally, a standard communication consists of four parts:

- 1) START or Repeated START signal generation
- 2) Slave address transfer
- 3) Data transfer
- 4) STOP signal generation

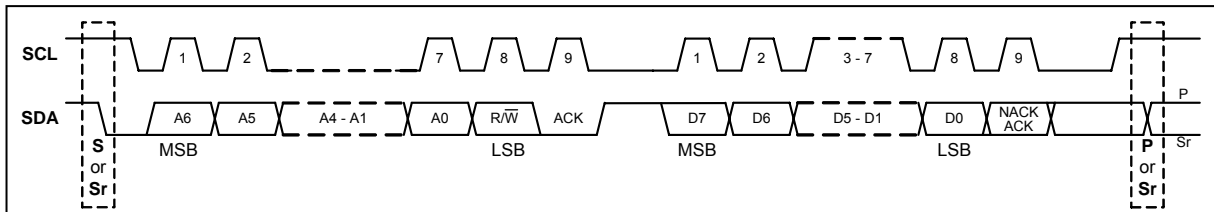
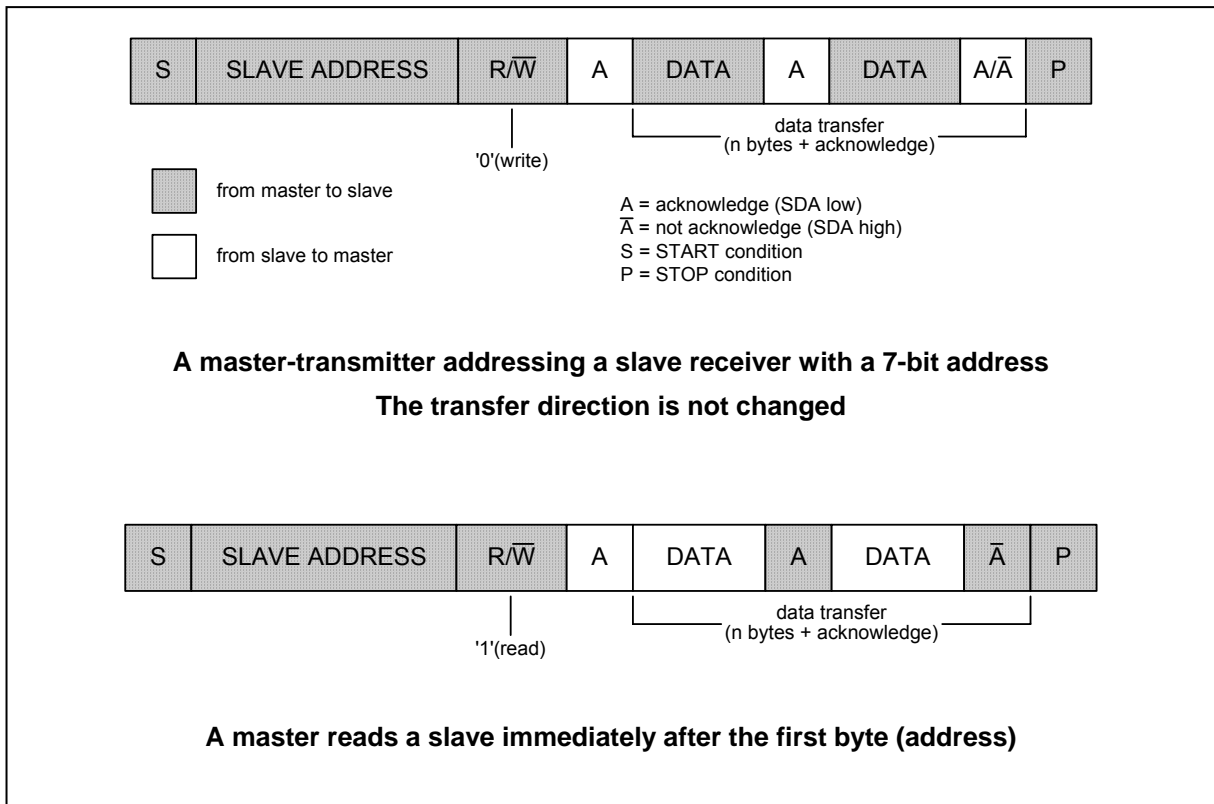

Fig. 6.18.1.1 Data transfer on the I²C-bus





START or Repeated START signal

When the bus is free/idle, meaning no master device is engaging the bus (both SCL and SDA lines are high), a master can initiate a transfer by sending a START signal. A START signal, usually referred to as the **S-bit** is defined as a **HIGH to LOW** transition on the SDA line, while SCL is **HIGH**. The START signal denotes the beginning of a new data transfer.

A Repeated START (Sr) is a START signal without first generating a STOP signal. The master uses this method to communicate with another slave or the same slave in a different transfer direction (e.g. from writing to a device to reading from a device) without releasing the bus.

The I²C core generates a START signal when the START bit in the Command Register (CMDR) is set and the READ or WRITE bits are also set. Depending on the current status of the SCL line, a START or Repeated START is generated.

STOP signal

The master can terminate communication by generating a STOP signal. A STOP signal is usually referred to as the **P-bit**, and is defined as a **LOW to HIGH** transition on the SDA line, while the SCL is **HIGH**.

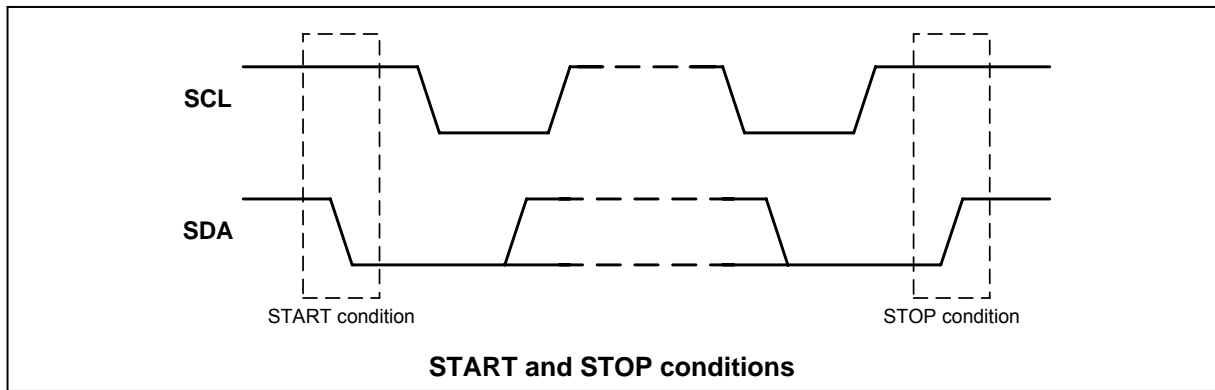

Slave Address Transfer

The first byte of data transferred by the master immediately after the START signal is the slave address. This is a 7-bit calling address followed by a RW bit. The RW bit signals the slave data transfer direction. No two slaves in the system can have the same address. Only the slave with an address that matches the one transmitted by the master will respond by returning an acknowledge bit by pulling the SDA low at the 9th SCL clock cycle.

The core treats Slave Address Transfer as any other write action. Store the slave device's address in the Transmit Register (TxR) and set the WRITE bit. The core then transfers the slave address on the bus.

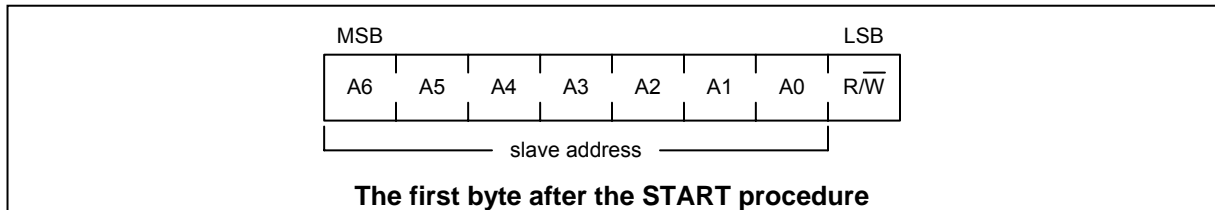



Data Transfer

Once slave addressing is complete, data transfer can proceed on a byte-by-byte basis in the direction specified by the RW bit sent by the master. Each transferred byte is followed by an acknowledge bit on the 9th SCL clock cycle. If the slave signals a **Not Acknowledge (NACK)**, the master can generate a STOP signal to abort the data transfer or generate a Repeated START signal and start a new transfer cycle.

If the master, as the receiving device, does **Not Acknowledge (NACK)** the slave, the slave releases the SDA line for the master to generate a STOP or Repeated START signal.

To write data to a slave, store the data to be transmitted in the Transmit Register (TxR) and set the WRITE bit. To read data from a slave, set the READ bit. During a transfer the core set the I2C_TIP flag, indicating that a **Transfer is In Progress**. When the transfer is done the I2C_TIP flag is cleared, the IF flag is set if enabled, and then generates an interrupt. The Receive Register (RxR) contains valid data after the IF flag has been set. The software may issue a new write or read command when the I2C_TIP flag is cleared.

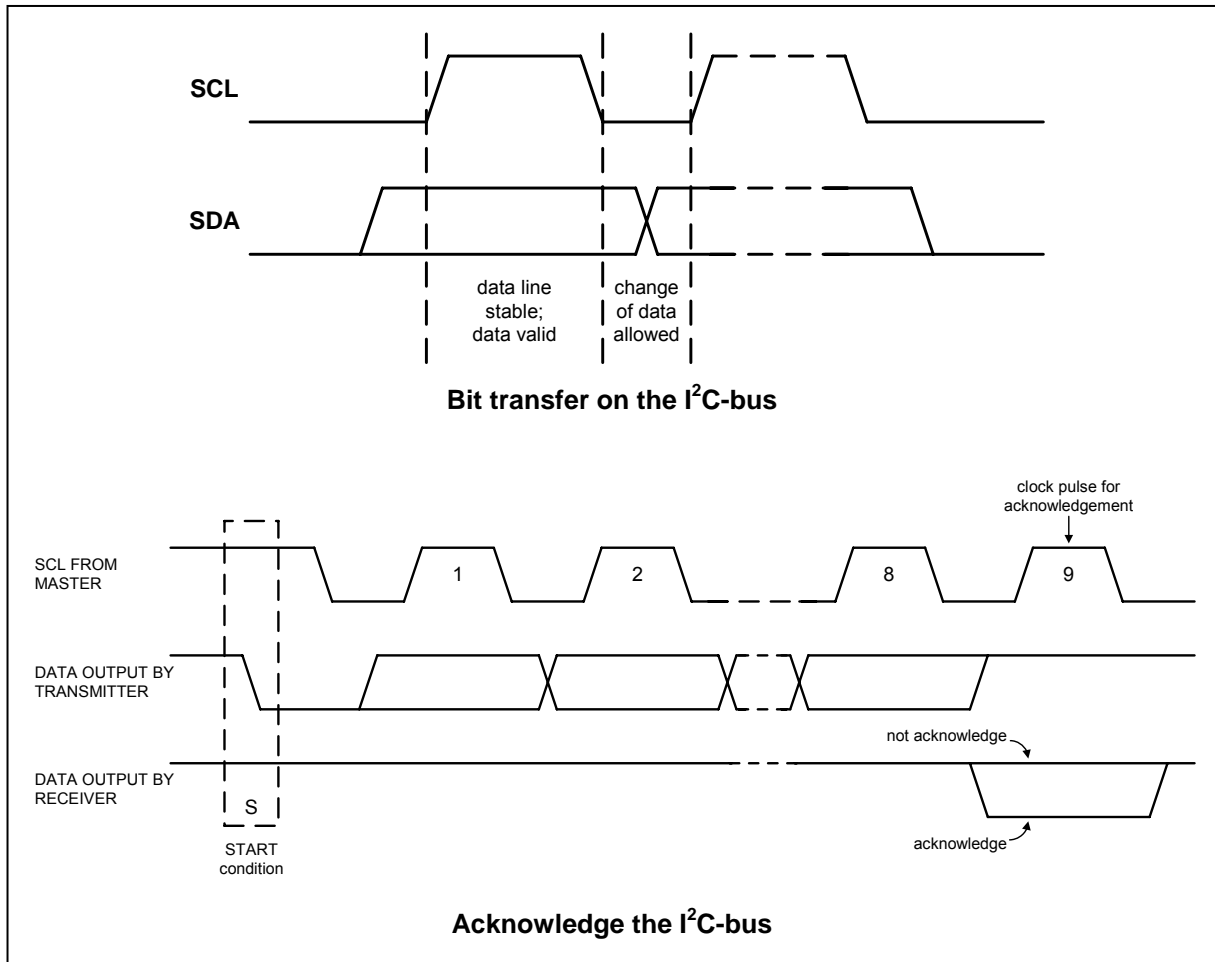



6.18.2 I2C Serial Interface Control Registers Map

R: read only, W: write only, R/W: both read and write

NOTE1: The reset value of I2C_SWR0/1 is 0x3F only when SCR, SDR and SER are connected to pull high resistor.

REGISTER	ADDRESS	R/W	DESCRIPTION	RESET VALUE
I2C Interface 0				
I2C_CSR0	0xFFFF8_6000	R/W	I2C0 Control and Status Register	0x0000_0000
I2C_DIVIDER0	0xFFFF8_6004	R/W	I2C0 Clock Prescale Register	0x0000_0000
I2C_CMDR0	0xFFFF8_6008	R/W	I2C0 Command Register	0x0000_0000
I2C_SWR0	0xFFFF8_600C	R/W	I2C0 Software Mode Control Register	0x0000_003F
I2C_RxR0	0xFFFF8_6010	R	I2C0 Data Receive Register	0x0000_0000
I2C_TxR0	0xFFFF8_6014	R/W	I2C0 Data Transmit Register	0x0000_0000
I2C Interface 1				
I2C_CSR1	0xFFFF8_6100	R/W	I2C1 Control and Status Register	0x0000_0000
I2C_DIVIDER1	0xFFFF8_6104	R/W	I2C1 Clock Prescale Register	0x0000_0000
I2C_CMDR1	0xFFFF8_6108	R/W	I2C1 Command Register	0x0000_0000
I2C_SWR1	0xFFFF8_610C	R/W	I2C1 Software Mode Control Register	0x0000_003F
I2C_RxR1	0xFFFF8_6110	R	I2C1 Data Receive Register	0x0000_0000
I2C_TxR1	0xFFFF8_6114	R/W	I2C1 Data Transmit Register	0x0000_0000

I2C Control and Status Register 0/1 (I2C_CSR0/1)

REGISTER	ADDRESS	R/W	DESCRIPTION	RESET VALUE
I2C_CSR0	0xFFFF8_6000	R/W	I2C Control and Status Register 0	0x0000_0000
I2C_CSR1	0xFFFF8_6100	R/W	I2C Control and Status Register 1	0x0000_0000

31	30	29	28	27	26	25	24
Reserved							
23	22	21	20	19	18	17	16
Reserved							
15	14	13	12	11	10	9	8
Reserved				I2C_RxACK	I2C_BUSY	I2C_AL	I2C_TIP
7	6	5	4	3	2	1	0
Reserved		Tx_NUM		Reserved	IF	IE	I2C_EN

W90P710CD/W90P710CDG



BITS	DESCRIPTIONS	
[31:12]	Reserved	Reserved
[11]	I2C_RxACK	Received Acknowledge From Slave (Read only) This flag represents acknowledge from the addressed slave. 0 = Acknowledge received (ACK). 1 = Not acknowledge received (NACK).
[10]	I2C_BUSY	I²C Bus Busy (Read only) 0 = After STOP signal detected. 1 = After START signal detected.
[9]	I2C_AL	Arbitration Lost (Read only) This bit is set when the I ² C core lost arbitration. Arbitration is lost when: A STOP signal is detected, but not requested. The master drives SDA high, but SDA is low.
[8]	I2C_TIP	Transfer In Progress (Read only) 0 = Transfer complete. 1 = Transferring data. NOTE: When a transfer is in progress, no writing to any I ² C register of the master core except for SWR is allowed.
[5:4]	Tx_NUM	Transmit Byte Counts These two bits represent how many bytes remain to transmit. When a byte has been transmitted, Tx_NUM would be subtracted by 1 until all bytes are transmitted (Tx_NUM = 0x0) or NACK received from slave. Then the interrupt signal will assert if IE was set. 0x0 = Only one byte is left for transmission. 0x1 = Two bytes are left for transmission. 0x2 = Three bytes are left for transmission. 0x3 = Four bytes are left for transmission.
[3]	Reserved	Reserved
[2]	IF	Interrupt Flag The Interrupt Flag is set when: Transfer is complete. Transfer is not yet complete, but slave responded NACK (in multi-byte transmit mode). Arbitration is lost. NOTE: This bit is read only, but can be cleared by writing 1 to this bit.
[1]	IE	Interrupt Enable 0 = Disable I ² C Interrupt. 1 = Enable I ² C Interrupt.
[0]	I2C_EN	I²C Core Enable 0 = Disable I ² C core, serial bus outputs are controlled by SDW/SCW. 1 = Enable I ² C core, serial bus outputs are controlled by the I ² C core.

W90P710CD/W90P710CDG



I2C Prescale Register 0/1 (I2C_DIVIDER 0 /1)

REGISTER	ADDRESS	R/W	DESCRIPTION	RESET VALUE
I2C_DIVIDER0	0xFFF8_6004	R/W	I2C Clock Prescale Register 0	0x0000_0000
I2C_DIVIDER1	0xFFF8_6104	R/W	I2C Clock Prescale Register 1	0x0000_0000

31	30	29	28	27	26	25	24
Reserved							
23	22	21	20	19	18	17	16
Reserved							
15	14	13	12	11	10	9	8
DIVIDER [15:8]							
7	6	5	4	3	2	1	0
DIVIDER [7:0]							

BITS	DESCRIPTIONS	
[15:0]	DIVIDER	<p>Clock Prescale Register Used to prescale the SCL clock line. Due to the structure of the I²C interface, the core uses an internal 5*SCL clock. The prescale register must be programmed to this 5*SCL frequency (minus 1). Change the value of the prescale register only when the "I2C_EN" bit is cleared. Example: pclk = 32MHz, desired SCL = 100KHz</p> $prescale = \frac{32 \text{ MHz}}{5 * 100 \text{ KHz}} - 1 = 63 (dec) = 3F (hex)$

I2C Command Register 0/1 (I2C_CMDR 0/1)

REGISTER	ADDRESS	R/W	DESCRIPTION	RESET VALUE
I2C_CMDR0	0xFFF8_6008	R/W	I2C Command Register 0	0x0000_0000
I2C_CMDR1	0xFFF8_6108	R/W	I2C Command Register 1	0x0000_0000

31	30	29	28	27	26	25	24
Reserved							
23	22	21	20	19	18	17	16
Reserved							
15	14	13	12	11	10	9	8
Reserved							
7	6	5	4	3	2	1	0
Reserved			START	STOP	READ	WRITE	ACK

NOTE: Software can write this register only when I2C_EN = 1.

W90P710CD/W90P710CDG



BITS	DESCRIPTIONS	
[31:5]	Reserved	Reserved
[4]	START	Generate Start Condition Generate (repeated) start condition on I ² C bus.
[3]	STOP	Generate Stop Condition Generate stop condition on I ² C bus.
[2]	READ	Read Data From Slave Retrieve data from slave.
[1]	WRITE	Write Data To Slave Transmit data to slave.
[0]	ACK	Send Acknowledge To Slave When I ² C behaves as a receiver, sent ACK (ACK = 0) or NACK (ACK = 1) to slave.

NOTE: The START, STOP, READ and WRITE bits are cleared automatically while transfer finished. READ and WRITE cannot be set concurrently.

I2C Software Mode Register 0/1(I2C_SWR 0/1)

REGISTER	ADDRESS	R/W	DESCRIPTION	RESET VALUE
I2C_SWR0	0xFFF8_600C	R/W	I2C Software Mode Control Register 0	0x0000_003F
I2C_SWR1	0xFFF8_610C	R/W	I2C Software Mode Control Register 1	0x0000_003F

31	30	29	28	27	26	25	24
Reserved							
23	22	21	20	19	18	17	16
Reserved							
15	14	13	12	11	10	9	8
Reserved							
7	6	5	4	3	2	1	0
Reserved		Reserved	SDR	SCR	Reserved	SDW	SCW

Note: This register is used as software mode of I²C. Software can read/write this register no matter I2C_EN is 0 or 1. But SCL and SDA are controlled by software only when I2C_EN = 0.

W90P710CD/W90P710CDG



BITS	DESCRIPTIONS	
[31:6]	Reserved	Reserved
[5]	Reserved	Reserved
[4]	SDR	Serial Interface SDA Status (Read only) 0 = SDA is Low. 1 = SDA is High.
[3]	SCR	Serial Interface SCK Status (Read only) 0 = SCL is Low. 1 = SCL is High.
[2]	Reserved	Reserved
[1]	SDW	Serial Interface SDA Output Control 0 = SDA pin is driven Low. 1 = SDA pin is tri-state.
[0]	SCW	Serial Interface SCK Output Control 0 = SCL pin is driven Low. 1 = SCL pin is tri-state.

I2C Data Receive Register 0/1 (I2C_RxR 0/1)

REGISTER	OFFSET	R/W	DESCRIPTION	RESET VALUE
I2C_RXR0	0xFFF8_6010	R	I2C Data Receive Register 0	0x0000_0000
I2C_RXR1	0xFFF8_6110	R	I2C Data Receive Register 1	0x0000_0000

31	30	29	28	27	26	25	24
Reserved							
23	22	21	20	19	18	17	16
Reserved							
15	14	13	12	11	10	9	8
Reserved							
7	6	5	4	3	2	1	0
Rx[7:0]							



BITS	DESCRIPTIONS	
[31:8]	Reserved	Reserved
[7:0]	Rx	Data Receive Register The last byte received via I ² C bus will put on this register. The I ² C core is only used by the 8-bit receive buffer.

I2C Data Transmit Register 0/1 (I2C_TxR 0/1)

REGISTER	ADDRESS	R/W	DESCRIPTION	RESET VALUE
I2C_TXR0	0xFFF8_6014	R/W	I2C Data Transmit Register	0x0000_0000
I2C_TXR1	0xFFF8_6114	R/W	I2C Data Transmit Register	0x0000_0000

31	30	29	28	27	26	25	24
Tx[31:24]							
23	22	21	20	19	18	17	16
Tx[23:16]							
15	14	13	12	11	10	9	8
Tx[15:8]							
7	6	5	4	3	2	1	0
Tx[7:0]							

BITS	DESCRIPTIONS	
[31:0]	Tx	Data Transmit Register The I ² C core uses 32-bit transmit buffer and provides a multi-byte transmission function. Set CSR[Tx_NUM] to the value that you want to transmit. I ² C core always issues a transfer from the highest byte first. For example, if CSR[Tx_NUM] = 0x3, Tx[31:24] is transmitted first, then Tx[23:16], and so on. In case of a data transfer, all bits are treated as data. In case of a slave address transfer, the first 7 bits are treated as a 7-bit address and the LSB represent the R/W bit. In this case, LSB = 1, reading from slave LSB = 0, writing to slave



6.19 Universal Serial Interface

The USI is a synchronous serial interface that performs a serial-to-parallel conversion on data characters received from the peripheral, and a parallel-to-serial conversion on data characters received from the CPU. This interface can drive an external peripheral and is seen as the master. It can generate an interrupt signal when data transfer is finished and can be cleared by writing 1 to the interrupt flag. The active level of device/slave select signal can be set as low active or high active, which depends on the connected peripheral. Writing a divisor into the DIVIDER register can program the frequency of the serial clock output. This master core contains four 32-bit transmit/receive buffers, and can provide burst mode operation. Up to 32 bits can be transmitted/received up to four times in succession during a single transfer.

The USI (Microwire/SPI) Master Core includes the following features:

- AMBA APB compatible interface
- Support USI (Microwire/SPI) master mode
- Full duplex synchronous serial data transfer
- Variable length of transfer word up to 32 bits
- Provide burst mode operation, transmit/receive can be executed up to four times in one transfer
- MSB or LSB first data transfer
- Rx and Tx independently on both rising or falling edges of the serial clock
- 1 slave/device select lines
- Fully static synchronous design with one clock domain

6.19.1 USI Timing Diagram

The timing diagram of USI is shown as follows:

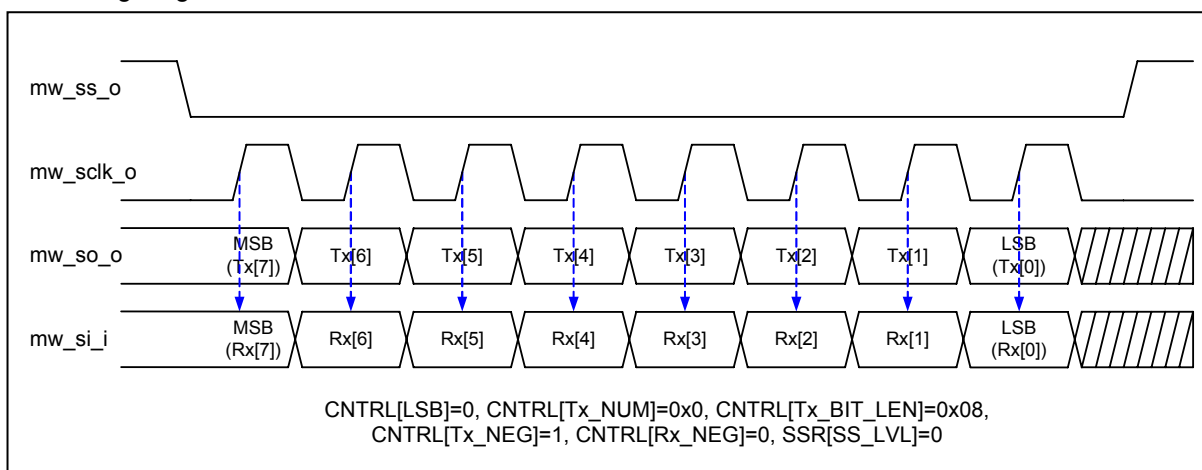

Fig. 6.19.1.1 USI Timing

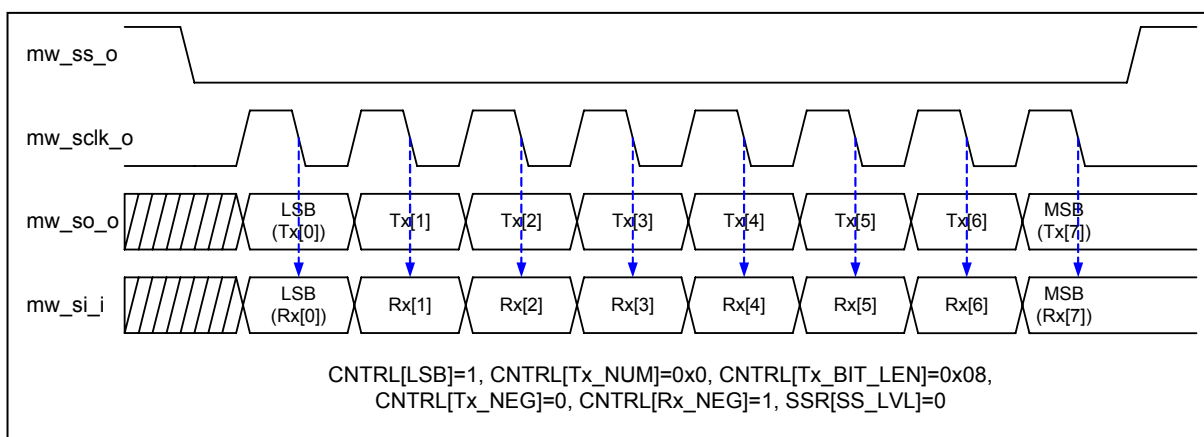

Fig. 6.19.1.2 Alternate Phase SCLK Clock Timing

6.19.2 USI Registers Map

R: read only, **W:** write only, **R/W:** both read and write

REGISTER	ADDRESS	R/W	DESCRIPTION	RESET VALUE
USI_CNTRL	0xFFFF8_6200	R/W	Control and Status Register	0x0000_0004
USI_DIVIDER	0xFFFF8_6204	R/W	Clock Divider Register	0x0000_0000
USI_SSR	0xFFFF8_6208	R/W	Slave Select Register	0x0000_0000
Reserved	0xFFFF8_620C	N/A	Reserved	N/A
USI_Rx0	0xFFFF8_6210	R	Data Receive Register 0	0x0000_0000
USI_Rx1	0xFFFF8_6214	R	Data Receive Register 1	0x0000_0000
USI_Rx2	0xFFFF8_6218	R	Data Receive Register 2	0x0000_0000
USI_Rx3	0xFFFF8_621C	R	Data Receive Register 3	0x0000_0000
USI_Tx0	0xFFFF8_6210	W	Data Transmit Register 0	0x0000_0000
USI_Tx1	0xFFFF8_6214	W	Data Transmit Register 1	0x0000_0000
USI_Tx2	0xFFFF8_6218	W	Data Transmit Register 2	0x0000_0000
USI_Tx3	0xFFFF8_621C	W	Data Transmit Register 3	0x0000_0000

NOTE 1: When the software programs CNTRL, the GO_BUSY bit should be written last.



USI_Control and Status Register (USI_CNTRL)

REGISTER	ADDRESS	R/W	DESCRIPTION	RESET VALUE
USI_CNTRL	0xFFF8_6200	R/W	USI Control and Status Register	0x0000_0004

31	30	29	28	27	26	25	24
Reserved							
23	22	21	20	19	18	17	16
Reserved						IE	IF
15	14	13	12	11	10	9	8
SLEEP				Reserved	LSB	Tx_NUM	
7	6	5	4	3	2	1	0
Tx_BIT_LEN					Tx_NEG	Rx_NEG	GO_BUSY

BITS	DESCRIPTIONS	
[31:18]	Reserved	Reserved
[17]	IE	Interrupt Enable 0 = Disable USI Interrupt. 1 = Enable USI Interrupt.
[16]	IF	Interrupt Flag 0 = Indicates the transfer is not finished. 1 = Indicates the transfer is complete. The interrupt flag is set if enabled. NOTE: This bit is read only, but can be cleared by writing 1.
[15:12]	SLEEP	Suspend Interval These four bits provide the configuration of suspend interval between two successive transmit/receive in a transfer. The default value is 0x0. When CNTRL [Tx_NUM] = 00, setting this field has no effect on transfer. The desired interval is obtained according to the following equation (from the last falling edge of current sclk to the first rising edge of the next sclk): $(CNTRL[SLEEP] + 2) * \text{period of SCLK}$ SLEEP = 0x0 ... 2 SCLK clock cycle SLEEP = 0x1 ... 3 SCLK clock cycle SLEEP = 0xe ... 16 SCLK clock cycle SLEEP = 0xf ... 17 SCLK clock cycle



Continued

BITS	DESCRIPTIONS	
[11]	Reserved	Reserved
[10]	LSB	<p>Send LSB First</p> <p>0 = The MSB is transmitted/received first (which bit in the TxX/RxX register depends on the Tx_BIT_LEN field in the CNTRL register).</p> <p>1 = The LSB is sent first on the line (bit TxX[0]), and the first bit received from the line is put in the LSB position in the Rx register (bit RxX[0]).</p>
[9:8]	Tx_NUM	<p>Transmit/Receive Numbers</p> <p>This field specifies how many transmit/receive numbers should be executed in one transfer.</p> <p>00 = Only one transmit/receive is executed in one transfer.</p> <p>01 = Two successive transmits/receives are executed in one transfer.</p> <p>10 = Three successive transmits/receives are executed in one transfer.</p> <p>11 = Four successive transmits/receives are executed in one transfer.</p>
[7:3]	Tx_BIT_LEN	<p>Transmit Bit Length</p> <p>This field specifies how many bits are transmitted in one transmit/receive. Up to 32 bits can be transmitted.</p> <p>Tx_BIT_LEN = 0x01 ... 1 bit</p> <p>Tx_BIT_LEN = 0x02 ... 2 bits</p> <p>.....</p> <p>Tx_BIT_LEN = 0x1f ... 31 bits</p> <p>Tx_BIT_LEN = 0x00 ... 32 bits</p>
[2]	Tx_NEG	<p>Transmit On Negative Edge</p> <p>0 = The mw_so_o signal is changed on the rising edge of mw_sclk_o.</p> <p>1 = The mw_so_o signal is changed on the falling edge of mw_sclk_o.</p>
[1]	Rx_NEG	<p>Receive On Negative Edge</p> <p>0 = The mw_si_i signal is latched on the rising edge of mw_sclk_o.</p> <p>1 = The mw_si_i signal is latched on the falling edge of mw_sclk_o.</p>
[0]	GO_BUSY	<p>Go and Busy Status</p> <p>0 = Writing 0 to this bit has no effect.</p> <p>1 = Writing 1 to this bit starts the transfer. This bit remains set during the transfer and is automatically cleared after the transfer finished.</p> <p>NOTE: All the registers should be set before writing 1 to the GO_BUSY bit in the CNTRL register. When a transfer is in progress, writing to any register of the USI(Microwire/SPI) master core has no effect.</p>

W90P710CD/W90P710CDG



USI Divider Register (USI_DIVIDER)

REGISTER	ADDRESS	R/W	DESCRIPTION	RESET VALUE
USI_Divider	0xFFF8_6204	R/W	USI Clock Divider Register	0x0000_0000

31	30	29	28	27	26	25	24
Reserved							
23	22	21	20	19	18	17	16
Reserved							
15	14	13	12	11	10	9	8
DIVIDER[15:8]							
7	6	5	4	3	2	1	0
DIVIDER[7:0]							

BITS	DESCRIPTIONS	
[15:0]	DIVIDER	<p>Clock Divider Register</p> <p>The value in this field is the frequency divider of the system clock pclk to generate the serial clock on the output usi_sclk_o. The desired frequency is obtained according to the following equation:</p> $f_{sclk} = \frac{f_{pclk}}{(DIVIDER + 1) * 2}$ <p>NOTE: Suggest DIVIDER should be at least 1.</p>

USI Slave Select Register (USI_SSR)

REGISTER	ADDRESS	R/W	DESCRIPTION	RESET VALUE
USI_SSR	0xFFF8_6208	R/W	USI Slave Select Register	0x0000_0000

31	30	29	28	27	26	25	24
Reserved							
23	22	21	20	19	18	17	16
Reserved							
15	14	13	12	11	10	9	8
Reserved							
7	6	5	4	3	2	1	0
Reserved				ASS	SS_LVL	SSR[1:0]	

W90P710CD/W90P710CDG



BITS	DESCRIPTIONS	
[3]	ASS	<p>Automatic Slave Select</p> <p>0 = If this bit is cleared, slave select signals are asserted and deasserted by setting and clearing related bits in the SSR register.</p> <p>1 = If this bit is set, <code>usi_ss_o</code> signals are generated automatically. This means that the device/slave select signal, which is set in the SSR register is asserted by the USI controller when transmit/receive is started by setting <code>CNTRL[GO_BUSY]</code>, and is deasserted after every transmit/receive is finished.</p>
[2]	SS_LVL	<p>Slave Select Active Level</p> <p>It defines the active level of device/slave select signal (<code>usi_ss_o</code>).</p> <p>0 = The <code>usi_ss_o</code> slave select signal is active Low.</p> <p>1 = The <code>usi_ss_o</code> slave select signal is active High.</p>
[1:0]	SSR	<p>Slave Select Register</p> <p>If <code>SSR[ASS]</code> bit is cleared, writing 1 to any bit location of this field sets the proper <code>sui_ss_o</code> line to an active state and writing 0 sets the line back to an inactive state.</p> <p>If <code>SSR [ASS]</code> bit is set, writing 1 to any bit location of this field will select an appropriate <code>sui_ss_o</code> line to be automatically driven to the active state for the duration of the transmit/receive, and is driven to the inactive state for the rest of the time (the active level of <code>usi_ss_o</code> is specified in <code>SSR [SS_LVL]</code>).</p> <p>NOTE: This interface can only drive one device/slave at a given time. Therefore, the slave select line of the selected device must be set to its active level before starting any read or write transfer.</p>

USI Data Receive Register 0/1/2/3 (USI_Rx0/1/2/3)

REGISTER	ADDRESS	R/W	DESCRIPTION	RESET VALUE
USI_RX0	0xFFF8_6210	R	USI Data Receive Register 0	0x0000_0000
USI_RX1	0xFFF8_6214	R	USI Data Receive Register 1	0x0000_0000
USI_RX2	0xFFF8_6218	R	USI Data Receive Register 2	0x0000_0000
USI_RX3	0xFFF8_621C	R	USI Data Receive Register 3	0x0000_0000

31	30	29	28	27	26	25	24
Rx[31:24]							
23	22	21	20	19	18	17	16
Rx[23:16]							
15	14	13	12	11	10	9	8
Rx[15:8]							
7	6	5	4	3	2	1	0
Rx[7:0]							

BITS	DESCRIPTIONS	
[31:0]	Rx	<p>Data Receive Register</p> <p>The Data Receive Registers hold the value of received data of the last executed transfer. Valid bits depend on the transmit bit length field in the CNTRL register. For example, if CNTRL[Tx_BIT_LEN] is set to 0x08 and CNTRL[Tx_NUM] is set to 0x0, bit Rx0[7:0] holds the received data.</p> <p>NOTE: The Data Receive Registers are read only registers. A Write to these registers actually modifies the Data Transmit Registers because those registers share the same FFs.</p>

W90P710CD/W90P710CDG



Data Transmit Register 0/1/2/3 (Tx0/1/2/3)

REGISTER	ADDRESS	R/W	DESCRIPTION	RESET VALUE
USI_TX0	0xFFF8_6210	W	USI Data Transmit Register 0	0x0000_0000
USI_TX1	0xFFF8_6214	W	USI Data Transmit Register 1	0x0000_0000
USI_TX2	0xFFF8_6218	W	USI Data Transmit Register 2	0x0000_0000
USI_TX3	0xFFF8_621C	W	USI Data Transmit Register 3	0x0000_0000

31	30	29	28	27	26	25	24
Tx[31:24]							
23	22	21	20	19	18	17	16
Tx[23:16]							
15	14	13	12	11	10	9	8
Tx[15:8]							
7	6	5	4	3	2	1	0
Tx[7:0]							

BITS	DESCRIPTIONS
[31:0]	<p>Data Transmit Register</p> <p>The Data Transmit Registers hold data to be transmitted in the next transfer. Valid bits depend on the transmit bit length field in the CNTRL register. For example, if CNTRL[Tx_BIT_LEN] is set to 0x08 and the CNTRL[Tx_NUM] is set to 0x0, the bit Tx0[7:0] is transmitted in next transfer. If CNTRL[Tx_BIT_LEN] is set to 0x00 and CNTRL[Tx_NUM] is set to 0x3, the core will perform four successive 32-bit transmits/receives using the same setting (the order is Tx0[31:0], Tx1[31:0], Tx2[31:0], Tx3[31:0]).</p> <p>NOTE: The RxX and TxX registers share the same flip-flops, which means that what is received from the input data line in one transfer is transmitted on the output data line in the next transfer if no write access to the TxX register is executed between transfers.</p>



6.20 PWM

W90P710 has 4-channel PWM timers. They can be divided into two groups. Each group has 1 prescaler, 1 clock divider, 2 clock selectors, 2 16-bit counters, 2 16-bit comparators, 1 Dead-Zone generator. They are all driven by PCLK (80 MHz). Each channel can be used as a timer and issue interrupts independently.

Two-channel PWM timers in one group share the same prescaler. Clock divider provides each channel with 5 clock sources (1, 1/2, 1/4, 1/8, 1/16). Each channel receives its own clock signal from the clock divider, which receives the clock signal from the 8-bit prescaler. The 16-bit counter of each channel receives clock signal from the clock selector and can be used to handle one PWM period. The 16-bit comparator compares number in the counter with the threshold number in register loaded previously to generate PWM duty cycle.

The clock signal from the clock divider is called the PWM clock. The Dead-Zone generator uses the PWM clock as a clock source. Once the Dead-Zone generator is enabled, the output of the two PWM timers in one group is blocked. The two output pins are all used as Dead-Zone generator output signals to control off-chip powered devices.

To prevent PWM driving the output pin with an unsteady waveform, 16-bit counter and 16-bit comparators are implemented with double buffering feature. The user is free to write data to the counter buffer register and comparator buffer register without problem.

When the 16-bit down counter reaches zero, PWM Timer would generate interrupt request to inform the CPU that time is up. When the counter reaches zero, if the counter is set as toggle mode, it is automatically reloaded and starts to generate the next cycle. The user can set the counter as one-shot mode instead of toggle mode. If the counter is set as one-shot mode, the counter stops and generates one interrupt request when it reaches zero.

The value of comparator is used for pulse width modulation. The counter control logic changes the output level when down-counter value matches the value of the compare register.

The PWM timer features are shown as below:

- Two 8-bit prescalers and two clock dividers
- Four clock selectors
- Four 16-bit counters and four 16-bit comparators
- Two Dead-Zone generators

6.20.1 PWM double buffering and automatic reload

W90P710 PWM Timers have a double buffering function, enabling the reload value to be changed for the next timer operation without stopping the current timer. Although the new timer value is set, current timer operation still operates successfully.

W90P710CD/W90P710CDG



The counter value can be written into PWM_CNR0, PWM_CNR1, PWM_CNR2, PWM_CNR3 and current counter value can be read from PWM_PDR0, PWM_PDR1, PWM_PDR2, and PWM_PDR3.

The auto-reload operation copies from PWM_CNR0, PWM_CNR1, PWM_CNR2, PWM_CNR3 to the countdown timer when it reaches zero. If PWM_CNR0~3 are set as zero, the counter is halted when the counter reaches zero. If auto-reload bit is set as zero, the counter is immediately stopped.

6.20.2 Modulate Duty Ratio

The double buffering function allows PWM_CMCR written at any point in current cycle. The loaded value will take effect from the next cycle.

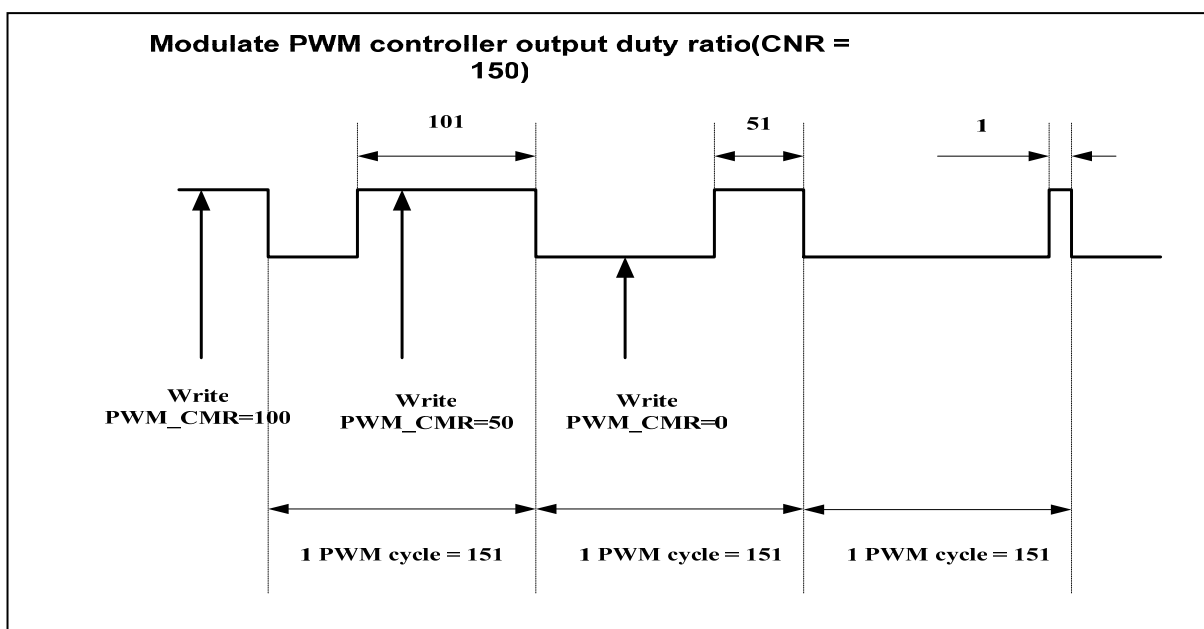

6.20.3 Dead Zone Generator

W90P710 PWM is implemented with Dead Zone generator. They are built for power device protection. This function enables generation of a programmable time gap at the rising edge of the PWM output waveform. User can program PWM_PPR [31:24] and PWM_PPR [23:16] to determine the Dead Zone interval.

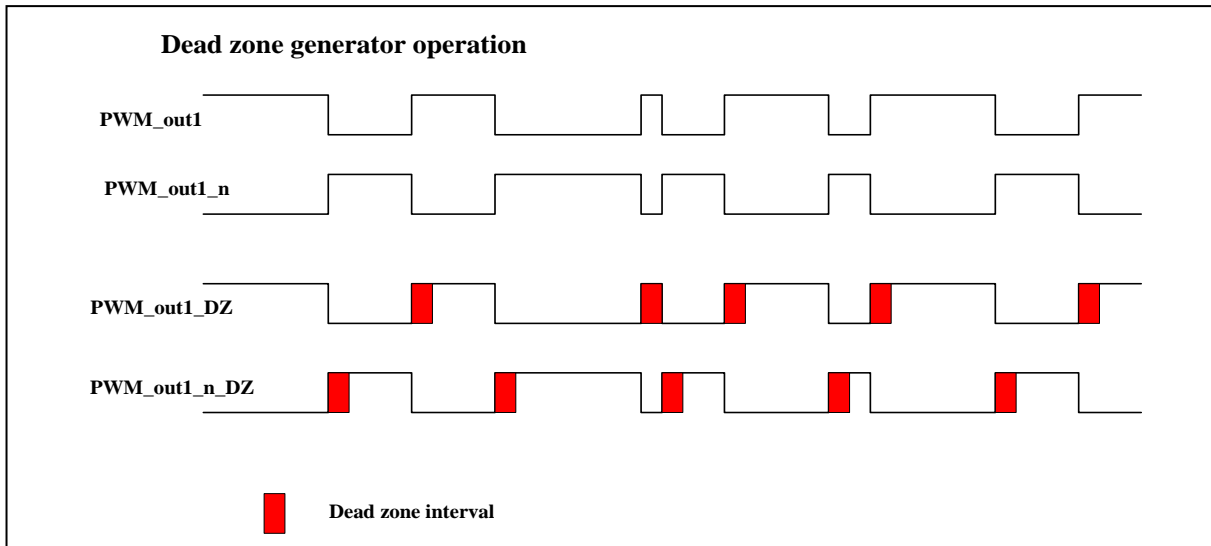

6.20.4 PWM Timer Start procedure

1. Setup clock selector (PWM_CSR)
2. Setup prescaler & dead zone interval (PWM_PPR)
3. Setup inverter on/off, dead zone generator on/off, toggle mode /one-shot mode, and PWM timer off. (PWM_PCR)
4. Setup comparator register (PWM_CMR)
5. Setup counter register (PWM_CNR)
6. Setup interrupt enable register (PWM_PIER)
7. Enable PWM timer (PWM_PCR)

6.20.5 PWM Timer Stop procedure

Method 1 : Set 16-bit down counter(PWM_CNR) as 0, and monitor PWM_PDR. When PWM_PDR reaches to 0, disable PWM timer (PWM_PCR). (Recommended)

Method 2 : Set 16-bit down counter(PWM_CNR) as 0. When the interrupt request occurs, disable the PWM timer (PWM_PCR). (Recommended)

Method 3 : Disable PWM timer directly (PWM_PCR). (Not recommended)



6.20.6 PWM Register Map

REGISTER	ADDRESS	R/W	DESCRIPTION	RESET VALUE
PWM_PPR	0xFFF8_7000	R/W	PWM Prescaler Register	0x0000_0000
PWM_CSR	0xFFF8_7004	R/W	PWM Clock Select Register	0x0000_0000
PWM_PCR	0xFFF8_7008	R/W	PWM Control Register	0x0000_0000
PWM_CNR0	0xFFF8_700C	R/W	PWM Counter Register 0	0x0000_0000
PWM_CMR0	0xFFF8_7010	R/W	PWM Comparator Register 0	0x0000_0000
PWM_PDR0	0xFFF8_7014	R	PWM Data Register 0	0x0000_0000
PWM_CNR1	0xFFF8_7018	R/W	PWM Counter Register 1	0x0000_0000
PWM_CMR1	0xFFF8_701C	R/W	PWM Comparator Register 1	0x0000_0000
PWM_PDR1	0xFFF8_7020	R	PWM Data Register 1	0x0000_0000
PWM_CNR2	0xFFF8_7024	R/W	PWM Counter Register 2	0x0000_0000
PWM_CMR2	0xFFF8_7028	R/W	PWM Comparator Register 2	0x0000_0000
PWM_PDR2	0xFFF8_702C	R	PWM Data Register 2	0x0000_0000
PWM_CNR3	0xFFF8_7030	R/W	PWM Counter Register 3	0x0000_0000
PWM_CMR3	0xFFF8_7034	R/W	PWM Comparator Register 3	0x0000_0000
PWM_PDR3	0xFFF8_7038	R	PWM Data Register 3	0x0000_0000
PWM_PIER	0xFFF8_703C	R/W	PWM Interrupt Enable Register	0x0000_0000
PWM_PIIR	0xFFF8_7040	R/C	PWM Interrupt Indication Register	0x0000_0000

PWM Prescaler Register (PWM_PPR)

REGISTER	ADDRESS	R/W	DESCRIPTION	RESET VALUE
PWM_PPR	0xFFF8_7000	R/W	PWM Prescaler Register	0x0000_0000

31	30	29	28	27	26	25	24
DZ11							
23	22	21	20	19	18	17	16
DZ10							
15	14	13	12	11	10	9	8
CP1							
7	6	5	4	3	2	1	0
CP0							

W90P710CD/W90P710CDG



BITS	DESCRIPTIONS	
[31:24]	DZ11	DZ11: Dead zone interval register 1, these 8 bits determine the dead zone length. The 1 unit time of dead zone length is received from the clock selector 2.
[23:16]	DZ10	DZ10: Dead zone interval register 0, these 8 bits determine the dead zone length. The 1 unit time of dead zone length is received from clock selector 0.
[15:8]	CP1	CP1 : Clock prescaler 1 for PWM Timer channel 2 & 3 Clock input is divided by (CP1 + 1) before it is fed to the counter. 2 & 3 If CP1=0, then the prescaler 1 output clock is stopped.
[7:0]	CP0	CP0 : Clock prescaler 0 for PWM Timer channel 0 & 1 Clock input is divided by (CP0 + 1) before it is fed to the counter. 0 & 1 If CP0=0, then the prescaler 0 output clock is stopped.

PWM Clock Select Register (PWM_CSR)

REGISTER	ADDRESS	R/W	DESCRIPTION	RESET VALUE
PWM_CSR	0xFFF8_7004	R/W	PWM Clock Select Register	0x0000_0000

31	30	29	28	27	26	25	24
Reserved							
23	22	21	20	19	18	17	16
Reserved							
15	14	13	12	11	10	9	8
Reserved	CSR3			Reserved	CSR2		
7	6	5	4	3	2	1	0
Reserved	CSR1			Reserved	CSR0		

BITS	DESCRIPTIONS	
[14:12]	CSR3	Select clock input for channel 3
[10:8]	CSR2	Select clock input for channel 2.
[6:4]	CSR1	Select clock input for channel 1
[2:0]	CSR0	Select clock input for channel 0

W90P710CD/W90P710CDG



CSR3	INPUT CLOCK DIVIDED BY
000	2
001	4
010	8
011	16
100	1

PWM Control Register (PWM_PCR)

REGISTER	ADDRESS	R/W	DESCRIPTION	RESET VALUE
PWM_PCR	0xFFF8_7008	R/W	PWM Control Register	0x0000_0000

31	30	29	28	27	26	25	24
Reserved							
23	22	21	20	19	18	17	16
Reserved				PCR19	PCR18	PCR17	PCR16
15	14	13	12	11	10	9	8
PCR15	PCR14	PCR13	PCR12	PCR11	PCR10	PCR09	PCR08
7	6	5	4	3	2	1	0
PCR07	PCR06	PCR05	PCR04	PCR03	PCR02	PCR01	PCR00

BITS	DESCRIPTIONS	
[19]	PCR 19	Channel 3 toggle/one shot mode 1 = Toggle mode 0 = One shot mode
[18]	PCR 18	Channel 3 Inverter on/off 1 = Inverter on 0 = Inverter off
[17]	PCR 17	Reserved
[16]	PCR 16	Channel 3 enable/disable 1 = Enable 0 = Disable
[15]	PCR 15	Channel 2 toggle/one shot mode 1 = Toggle mode 0 = One shot mode

W90P710CD/W90P710CDG



Continued

BITS	DESCRIPTIONS	
[14]	PCR 14	Channel 2 Inverter on/off 1 = Inverter on 0 = Inverter off
[13]	PCR 13	Reserved
[12]	PCR 12	Channel 2 enable/disable 1 = Enable 0 = Disable
[11]	PCR 11	Channel 1 toggle/one shot mode 1 = Toggle mode 0 = One shot mode
[10]	PCR 10	Channel 1 Inverter on/off 1 = Inverter on 0 = Inverter off
[09]	PCR 09	Reserved
[08]	PCR 08	Channel 1 enable/disable 1 = Enable 0 = Disable
[07]	PCR 07	Reserved
[06]	PCR 06	Reserved
[05]	PCR 05	Dead-Zone generator 1 enable/disable 1 = Enable dead-zone generator 0 = Disable dead-zone generator
[04]	PCR 04	Dead-Zone generator 0 enable/disable 1 = Enable dead-zone generator 0 = Disable dead-zone generator
[03]	PCR 03	Channel 0 toggle/one shot mode 1 = Toggle mode 0 = One shot mode
[02]	PCR 02	Channel 0 Inverter on/off 1 = Inverter on 0 = Inverter off
[01]	PCR 01	Reserved
[00]	PCR 00	Channel 0 enable/disable 1 = Enable 0 = Disable

W90P710CD/W90P710CDG



PWM Counter Register 0/1/2/3 (PWM_CNR0/1/2/3)

REGISTER	ADDRESS	R/W	DESCRIPTION	RESET VALUE
PWM_CNR0	0xFFF8_700C	R/W	PWM Counter Register 0	0x0000_0000
PWM_CNR1	0xFFF8_7018	R/W	PWM Counter Register 1	0x0000_0000
PWM_CNR2	0xFFF8_7024	R/W	PWM Counter Register 2	0x0000_0000
PWM_CNR3	0xFFF8_7030	R/W	PWM Counter Register 3	0x0000_0000

31	30	29	28	27	26	25	24
Reserved							
23	22	21	20	19	18	17	16
Reserved							
15	14	13	12	11	10	9	8
CNRx[15:8]							
7	6	5	4	3	2	1	0
CNRx[7:0]							

BITS	DESCRIPTIONS	
[31:16]	Reserved	-
[15:0]	CNRx	<p>CNR: PWM counter/timer buffer. Inserted data range: 65535~0. Unit: 1 PWM clock cycle</p> <p>Note 1: One PWM counter countdown interval = CNR + 1. If the CNR is loaded as zero, the PWM counter is stopped.</p> <p>Note 2: Programmer can write data to the CNR at any time, which is reloaded when the PWM counter reaches zero.</p>

PWM Comparator Register 0/1/2/3 (PWM_CMRO/1/2/3)

REGISTER	ADDRESS	R/W	DESCRIPTION	RESET VALUE
PWM_CMRO	0xFFF8_7010	R/W	PWM Comparator Register 0	0x0000_0000
PWM_CMRO1	0xFFF8_701C	R/W	PWM Comparator Register 1	0x0000_0000
PWM_CMRO2	0xFFF8_7028	R/W	PWM Comparator Register 2	0x0000_0000
PWM_CMRO3	0xFFF8_7034	R/W	PWM Comparator Register 3	0x0000_0000

W90P710CD/W90P710CDG



31	30	29	28	27	26	25	24
Reserved							
23	22	21	20	19	18	17	16
Reserved							
15	14	13	12	11	10	9	8
CMRx[15:8]							
7	6	5	4	3	2	1	0
CMRx[7:0]							

BITS	DESCRIPTIONS	
[31:16]	Reserved	-
[15:0]	CMRx	<p>CMR: PWM comparator register Inserted data range: 65535~0. CMR is used to determine PWM output duty ratio.</p> <p>Note 1: PWM duty = CMR + 1.If CMR is loaded as zero, PWM duty = 1</p> <p>Note 2: Programmer can feel free to write data to CMR at any time, and it is reloaded when PWM counter reaches zero.</p>

PWM Data Register 0/1/2/3 (PWM_PDR 0/1/2/3)

REGISTER	ADDRESS	R/W	DESCRIPTION	RESET VALUE
PWM_PDR0	0xFFF8_7014	R	PWM Data Register 0	0x0000_0000
PWM_PDR1	0xFFF8_7020	R	PWM Data Register 1	0x0000_0000
PWM_PDR2	0xFFF8_702C	R	PWM Data Register 2	0x0000_0000
PWM_PDR3	0xFFF8_7038	R	PWM Data Register 3	0x0000_0000

31	30	29	28	27	26	25	24
Reserved							
23	22	21	20	19	18	17	16
Reserved							
15	14	13	12	11	10	9	8
PDRx[15:8]							
7	6	5	4	3	2	1	0
PDRx[7:0]							



BITS	DESCRIPTIONS	
[31:16]	Reserved	-
[15:0]	PDRx	PDR: PWM Data register. User can monitor PDR to get current value in 16-bit down counter.

PWM Interrupt Enable Register (PWM_PIER)

REGISTER	ADDRESS	R/W	DESCRIPTION	RESET VALUE
PWM_PIER	0xFFF8_703C	R/W	PWM Interrupt Enable Register	0x0000_0000

31	30	29	28	27	26	25	24
Reserved							
23	22	21	20	19	18	17	16
Reserved							
15	14	13	12	11	10	9	8
Reserved							
7	6	5	4	3	2	1	0
Reserved				PIER3	PIER2	PIER1	PIER0

BITS	DESCRIPTIONS	
[31:4]	Reserved	-
[3]	PIER3	Enable/Disable PWM counter channel 3 interrupt request 1 = Enable 0 = Disable
[2]	PIER2	Enable/Disable PWM counter channel 2 interrupt request 1 = Enable 0 = Disable
[1]	PIER1	Enable/Disable PWM counter channel 1 interrupt request 1 = Enable 0 = Disable
[0]	PIER0	Enable/Disable PWM counter channel 0 interrupt request 1 = Enable 0 = Disable



PWM Interrupt Indication Register (PWM_PIIR)

REGISTER	ADDRESS	R/W/C	DESCRIPTION	RESET VALUE
PWM_PIIR	0xFFFF8_7040	R/C	PWM Interrupt Indication Register	0x0000_0000

31	30	29	28	27	26	25	24
Reserved							
23	22	21	20	19	18	17	16
Reserved							
15	14	13	12	11	10	9	8
Reserved							
7	6	5	4	3	2	1	0
Reserved				PIIR3	PIIR2	PIIR1	PIIR0

BITS	DESCRIPTIONS	
[3]	PIIR3	PWM counter channel 3 interrupt flag
[2]	PIIR2	PWM counter channel 2 interrupt flag
[1]	PIIR1	PWM counter channel 1 interrupt flag
[0]	PIIR0	PWM counter channel 0 interrupt flag
Note: User can clear each interrupt flag by writing a zero to corresponding bit in PIIR		

6.21 Keypad Interface

W90P710 Keypad Interface (KPI) is an APB slave with 4-row scan output and 8-column scan input. KPI scans an array up to 16x8 with an external 4 to 16 decoder. It can also be programmed to scan 8x8 or 4x8 key array. If the 4x8 array is selected then external decoder is not necessary because the scan signals are dived by W90P710 itself. For minimum pin counts application, an auxiliary priority encoder (TTL 74148) can be used to encode 8 columns input to 3 binary code and one indicator flag. Total 8 pins are required to implement 16x8 key scan.

Any 1 or 2 keys in the array that pressed are debounced and encoded. The keypad controller scan key matrix from ROW0 COL 0 → 1 → 2 → 7, ROW1 COL 0 → 1 → 2 ... → 7 till to ROW 16 (or ROW 8 or ROW 4) COL 0 → 0 → 1 → 7. If more than 2 keys are pressed, only the keys or apparent keys in the array with the lowest address are decoded.

KPI also supports 2-keys scan interrupt and specifies 3-key interrupt or chip reset. If 3 pressed keys match the 3 keys defined in KPI3KCONF, an interrupt is generated or chip reset to nWDOG reset output depend on the ENRST setting. The interrupt is generated whenever the scanner detects a key is pressed. The interrupt conditions are 1 key, 2 keys and 3 keys.

W90P710CD/W90P710CDG



W90P710 provides two keypad-connecting interfaces. One is allocated in the LCD (GPIO30-41) interface, the other is in Ethernet RMI PHY interface and I2C interface 2 SDA1, SCL1 (GPIO42-51). Software should set KPSEL bit in KPICONF register to decide which interface is used as the keypad connection port.

The keypad interface has the following features:

- Maximum 16x8 array
- Programmable debounce time
- Low-power wakeup mode
- Programmable three-key reset

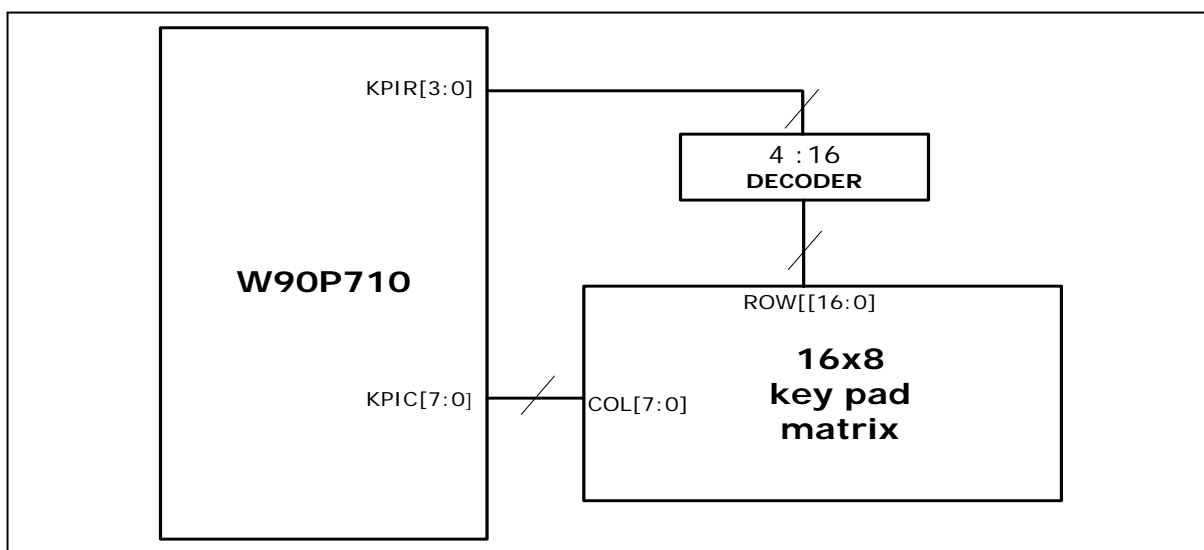

Fig. 6.21.1 W90P710 Keypad Interface

6.21.1 Keypad Interface Register Map

REGISTER	ADDRESS	R/W	DESCRIPTION	RESET VALUE
KPICONF	0xFFF8_8000	R/W	Keypad controller configuration Register	0x0000_0000
KPI3KCONF	0xFFF8_8004	R/W	Keypad controller 3-keys configuration register	0x0000_0000
KPILPCONF	0xFFF8_8008	R/W	Keypad controller low power configuration register	0x0000_0000
KPISTATUS	0xFFF8_800C	R/O	Keypad controller status register	0x0000_0000



6.21.2 Register Description

Keypad Controller Configuration Register (KPI_CONF)

REGISTER	ADDRESS	R/W	DESCRIPTION	RESET VALUE
KPICONF	0xFFF8_8000	R/O	Keypad configuration register	0x0000_0000

31	30	29	28	27	26	25	24
RESERVED							
23	22	21	20	19	18	17	16
RESERVED		ENCODE	ODEN	KPSEL	ENKP	KSIZE	
15	14	13	12	11	10	9	8
DBTC							
7	6	5	4	3	2	1	0
PRESCALE							

BITS	DESCRIPTION	
[31:22]	RESERVED	-
[21]	ENCODE	<p>Enable Encode Function</p> <p>If an auxiliary 8 to 3 encoder is used to minimize keypad interface pin counts, user can connect encoder data to KPCOL [2:0] and indicator flag (low active) to KPCOL [3].</p> <p>1 = Enable encoder function 0 = Default. (8 column inputs)</p>
[20]	ODEN	<p>Open Drain Enable</p> <p>If there is more than one key pressed in the same column, then a "short-circuit" occurs between the active scan and inactive scan row. Software can set this bit HIGH to enable scan output KPROW [3:0] pins work as "open-drain" to avoid the "short-circuit".</p> <p>1 = Open drain 0 = Push-pull driver</p>
[19]	KPSEL	<p>Keypad select</p> <p>W90P710 provide two interfaces for keypad function. Software should set this bit to select which interface is used to connect the keypad matrix.</p> <p>1 = Pin #23 ~34 is used as keypad interface 0 = Pin #81~88 and #19, #20 are used as keypad interface</p>

W90P710CD/W90P710CDG



Continued

BITS	DESCRIPTION									
[18]	ENKP	<p>Keypad scan enable</p> <p>Setting this bit high enable the key scan function.</p> <p>1 = Enable keypad scan</p> <p>0 = Disable keypad scan</p>								
[17:16]	KSIZE	<p>Key array size</p> <table border="1" data-bbox="649 611 1396 800"> <thead> <tr> <th data-bbox="654 617 792 659">KSIZE</th> <th data-bbox="792 617 1391 659">Key array size</th> </tr> </thead> <tbody> <tr> <td data-bbox="654 659 792 701">2'b00</td> <td data-bbox="792 659 1391 701">4x8, 3x8, 2x8, 1x8</td> </tr> <tr> <td data-bbox="654 701 792 743">2'b01</td> <td data-bbox="792 701 1391 743">8x8, 7x8, 6x8, 5x8</td> </tr> <tr> <td data-bbox="654 743 792 800">2'b1x</td> <td data-bbox="792 743 1391 800">16x8, 15x8, 14x8, 13x8, 12x8, 11x8, 10x8, 9x8</td> </tr> </tbody> </table>	KSIZE	Key array size	2'b00	4x8, 3x8, 2x8, 1x8	2'b01	8x8, 7x8, 6x8, 5x8	2'b1x	16x8, 15x8, 14x8, 13x8, 12x8, 11x8, 10x8, 9x8
KSIZE	Key array size									
2'b00	4x8, 3x8, 2x8, 1x8									
2'b01	8x8, 7x8, 6x8, 5x8									
2'b1x	16x8, 15x8, 14x8, 13x8, 12x8, 11x8, 10x8, 9x8									
[15:8]	DBTC	<p>Debounce terminal count</p> <p>Debounce counter counts the number of consecutive scans that decoded the same keys. When the debounce counter is equal to the terminal count it will generate a key scan interrupt.</p>								
[7:0]	PRESCALE	<p>Row scan cycle pre-scale value</p> <p>This value is used to prescale row scan cycle. The prescale counter is clocked by 0.9375MHz clock.</p> <p>Key array scan time = 1.067us x PRESCALE x16 ROWS</p> <p>The following example is the scan time for PRESCALE = 0xFA</p> <p>Tscan_time = 1.067us x 250 x16 = 4.268ms</p> <p>If debounce terminal count = 0x05, a key detection interrupt is fired in approximately 21.34ms. The array scan time can range from 17.07us to 1.118 sec.</p>								

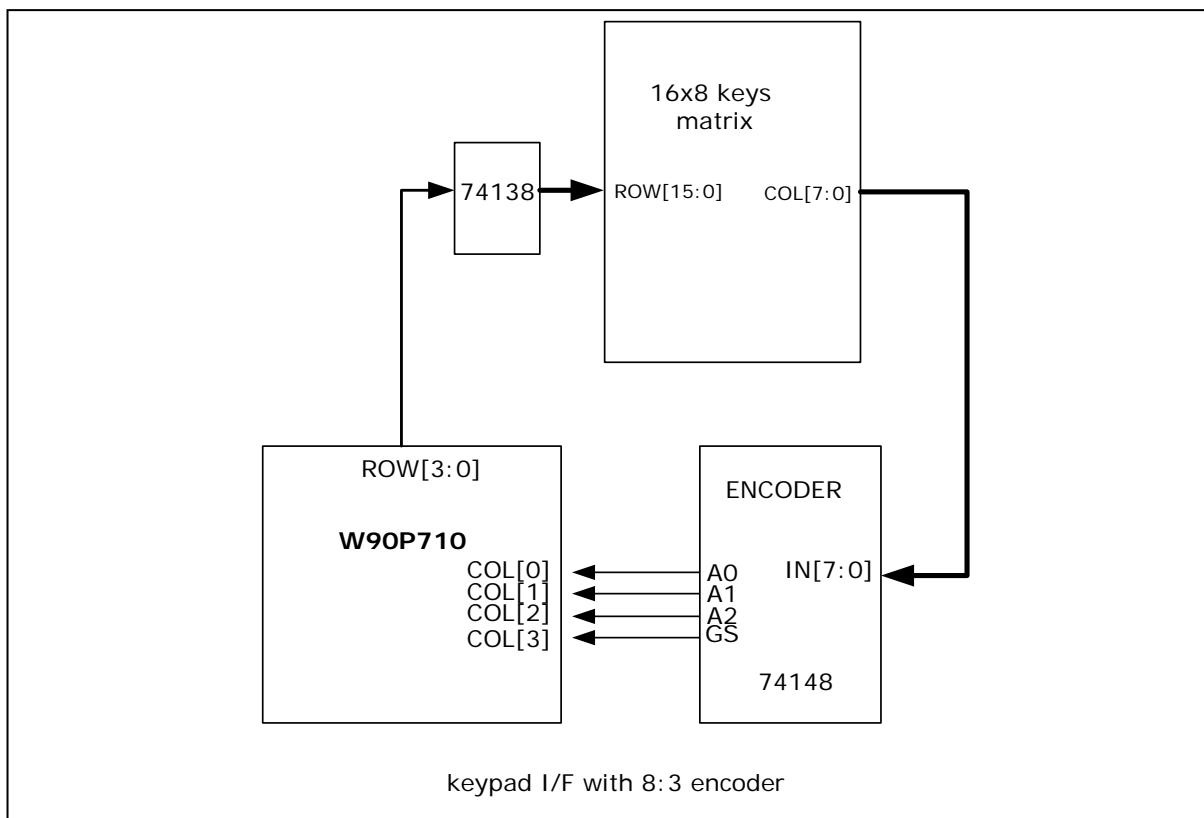

Fig. 6.21.1 Keypad Interface with row decoder and column encoder

Keypad Controller 3-keys Configuration Register (KPI3KCONF)

REGISTER	ADDRESS	R/W	DESCRIPTION	RESET VALUE
KPI3KCONF	0xFFF8_8004	W/R	three-key configuration register	0x0000_0000

31	30	29	28	27	26	25	24
RESERVED						EN3KY	ENRST
23	22	21	20	19	18	17	16
RESERVED	K32R				K32C		
15	14	13	12	11	10	9	8
RESERVED	K31R				K31C		
7	6	5	4	3	2	1	0
RESERVED	K30R				K30C		

W90P710CD/W90P710CDG



BITS		DESCRIPTION												
[31:26]	RESERVED	-												
[25]	EN3KY	Enable three-keys detection Setting this bit enables hardware to detect 3 keys specified by software												
[24]	ENRST	Enable three-key reset Setting this bit enable hardware reset when the three-keys are detected. <table border="1" data-bbox="657 718 1398 903" style="margin-left: 40px;"> <thead> <tr> <th>EN3KY</th> <th>ENRST</th> <th>Function</th> </tr> </thead> <tbody> <tr> <td>0</td> <td>X</td> <td>three-key function is disabled</td> </tr> <tr> <td>1</td> <td>0</td> <td>generate three-key interrupt</td> </tr> <tr> <td>1</td> <td>1</td> <td>hardware reset by three-key-reset</td> </tr> </tbody> </table>	EN3KY	ENRST	Function	0	X	three-key function is disabled	1	0	generate three-key interrupt	1	1	hardware reset by three-key-reset
EN3KY	ENRST	Function												
0	X	three-key function is disabled												
1	0	generate three-key interrupt												
1	1	hardware reset by three-key-reset												
[23]	RESERVED	-												
[22:19]	K32R	The #2 key row address The #2 means the row address and the column address is the highest of the specified 3-kyes.												
[18:16]	K32C	The #2 key column address												
[15]	RESERVED	-												
[14:11]	K31R	The #1 key row address The #1 means the row address and the column address is the 2nd of the specified 3-kyes.												
[10:8]	K31C	The #1 key column address												
[7]	RESERVED	-												
[6:3]	K30R	The #0 key row address The #0 means the row address and the column address is the lowest of the specified 3-kyes.												
[2:0]	K30C	The #0 key column address												

Application Note: Due to hardware scan from {row[0], col[0]}, {row[0], col[1]}, ..., to {row[15], col[7]} the {K30R,K30C} should be filled the lowest address of the three-keys. For example, if {2,0} {4,6}, {1,3} keys are defined as three-keys. Software should set {K30R, K30C} = {1, 3}, {K31R, K31C} = {2, 0} and {K32R, K32C} = {4, 6}.

W90P710CD/W90P710CDG



Keypad Interface Low Power Mode Configuration Register (KPILPCONF)

REGISTER	ADDRESS	R/W	DESCRIPTION	RESET VALUE
KPILPCOF	0xFFFF8_8008	R/W	Low power configuration register	0x0000_0000

31	30	29	28	27	26	25	24
RESERVED							
23	22	21	20	19	18	17	16
							WAKE
15	14	13	12	11	10	9	8
LPWCEN							
7	6	5	4	3	2	1	0
RESERVED				LPWR			

BITS	DESCRIPTION	
[31:17]	RESERVED	-
[16]	WAKE	<p>Lower power wakeup enable</p> <p>Setting this bit enables low power wakeup</p> <p>1 = Wakeup enable</p> <p>0 = Not enable</p>
[15:8]	LPWCEN	<p>Low power wakeup column enable</p> <p>Specify columns for low power wakeup. For example, if user wants to use keys in row N and column 0, 2, 5 to wake up W90P710, then the LPWCEN should be fill 8'b00100101.</p> <p>Application restriction: when ENCODE=1 case, LPWCEN should be set as 0xFF i.e., all columns in specified row are used as wake up input.</p> <p>In this case, user cannot specify special column(s) to wake up W90P710.</p>
[7:4]	RESERVED	-
[3:0]	LPWR	<p>Low power wakeup row address</p> <p>Define the row address keys used to wakeup. For 16x8 or 8x8 (with 4:16 or 3:8 decoder) keypad key configuration, LPWR means "Hex" code but for 4x8 (without decoder), LPWR means "binary" code. For example, if the user wants to use all keys on row 3 of 16x8 keypad to wakeup W90P710, then 0x3 should be fill into this register but for 4x8 keypad it should be filled as 4'b1000.</p>

W90P710CD/W90P710CDG



Keypad Interface Status Register (KPISTATUS)

REGISTER	ADDRESS	R/W	DESCRIPTION	RESET VALUE
KPISTATUS	0xFFF8_800C	R/O	Keypad status register	0x0000_0000

31	30	29	28	27	26	25	24
RESERVED							
23	22	21	20	19	18	17	16
RESERVED		INT	3KRST	PDWAKE	3KEY	2KEY	1KEY
15	14	13	12	11	10	9	8
RESERVED		KEY1R			KEY1C		
7	6	5	4	3	2	1	0
RESERVED		KEY0R			KEY0C		

BITS	DESCRIPTION	
[31:22]	RESERVED	-
[21]	INT	<p>Key interrupt</p> <p>This bit indicates the key scan interrupt is active and that one or two keys have changed status. The interrupt also occur when the three specified keys are detected if ENRST bit in KPI3KFCON is cleared.</p> <p>It is cleared by hardware automatically when software read KPISTATUS register.</p>
[20]	3KRST	<p>3-Keys reset flag</p> <p>This bit is a record flag for software reference; it is set after a 3-key reset.</p> <p>1 = 3 keys reset 0 = No reset.</p> <p>This bit is cleared while it is read.</p>
[19]	PDWAKE	<p>Power Down Wakeup flag</p> <p>This flag indicates the chip is wakeup from power down by keypad</p> <p>1 = Wakeup up by keypad 0 = No wakeup</p>
[18]	3KEY	<p>Specified three-key is detected.</p> <p>This flag indicates specified-three-keys were detected. Software can read this bit to know the keypad interrupt is 3 keys or not.</p>

W90P710CD/W90P710CDG



Continued

BITS	DESCRIPTION	
[17]	2KEY	Double-key press This bit indicates that 2 keys have been detected. Software can read {KEY1R, KEY1C} and {KEY0R, KEY0C} to know which two keys are pressed.
[16]	1KEY	Single-key press This bit indicates that 1 key has been detected. Software can read {KEY0R, KEY0C} to know which key is pressed.
[15]	RESERVED	-
[14:11]	KEY1R	KEY1 row address This value indicates key1 row address. The keypad controller scan keypad matrix from row 0, column0 →1 →2 → 7 and then row1 column 0 → 1 → 2 →7 so the lowest key address is stored in {KEY0R, KEY0C}. This register stores the 2 nd address, if more than one key is pressed.
[10:8]	KEY1C	KEY1 column address This value indicates key1 column address..
[7]	RESERVED	-
[6:3]	KEY0R	KEY1 row address This value indicates key0 row address. This value indicates key1 row address. The keypad controller scan keypad matrix from row 0, column0 →1 →2 → 7 and then row1 col 0 → 1 → 2 → ...→ 7 still to row16 (or 8, or 4) column 0 → 1 → 2 → 7 so the lowest key address is stored in {KEY0R, KEY0C}.
[2:0]	KEY0C	KEY1 column address This value indicates key0 row address.



6.22 PS2 Host Interface Controller

W90P710 PS2 host controller interface is an APB slave consisted of PS2 protocol. It is used to connect to your IBM keyboard or other device through PS2 interface. For example, the IBM keyboard will send scan codes to the host controller, and the scan codes will tell your Keyboard Bios what keys you have pressed or released. Besides Scan codes, commands can also be sent to the keyboard from host. The most common commands would be the setting/resetting of the status indicators (i.e. the Num lock, Caps Lock & Scroll Lock LEDs).

The PS2 interface implements a bi-directional protocol. The keyboard can send data to the Host and the Host can send data to the Keyboard using two PS2 Clock and PS2 Data lines. Both the PS2 Clock and Data lines are Open Collector bi-directional I/O lines. The Host has the ultimate priority over direction. The keyboard is free to send data to the host when both the PS2 Data and PS2 Clock lines are high (Idle). If the host takes the PS2 Clock line low, the keyboard will buffer any data until the PS2 Clock is released, i.e. goes high. The transmission of data in the forward direction, i.e. Keyboard to Host is done with a frame of 11 bits. The first bit is a Start Bit (Logic 0) followed by 8 data bits (LSB First), one Parity Bit (Odd Parity) and a Stop Bit (Logic 1). Each bit should be read on the falling edge of the clock. The Keyboard will generate the clock. The frequency of the clock signal typically ranges from 20 to 30 KHz.

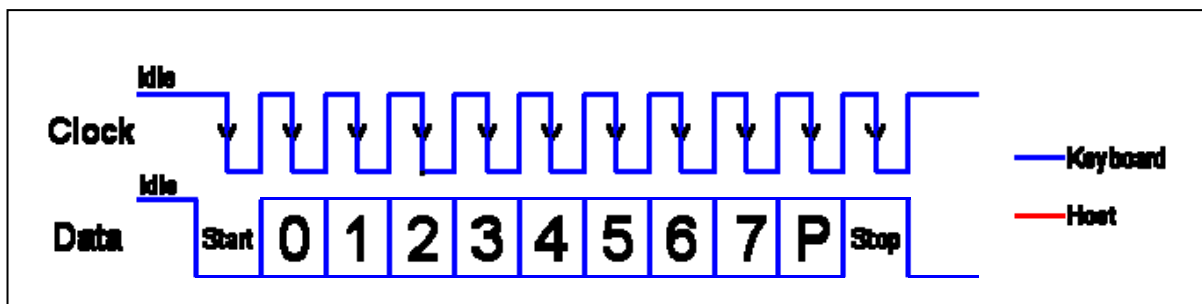

The Host to Keyboard Protocol is initiated by taking the PS2 data line low. It is common to take the PS2 Clock line low for more than 60us and then the KBD data line is taken low, while the KBD clock line is released. After that, the keyboard will start generating a clock signal on its PS2 clock line. After the first falling edge has been detected, host will load the first data bit on the PS2 Data line. This bit is read into the keyboard on the next falling edge, after which the host places the next bit of data. This process is repeated for the 8 data bits. It will follow an Odd Parity Bit after the data byte.

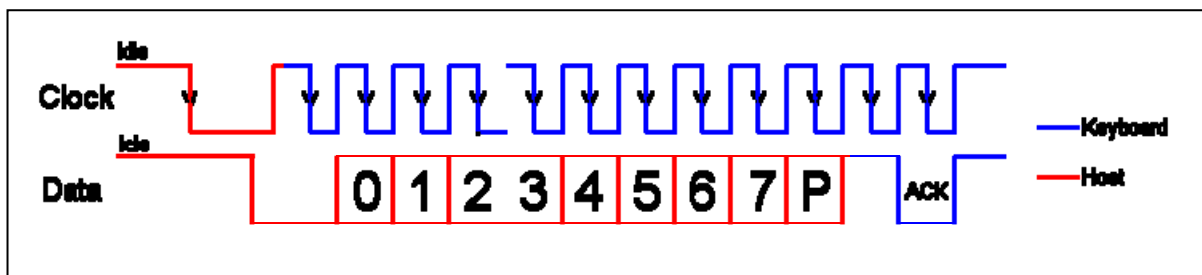



6.2.2.1 PS2 Host Controller Interface Register Map

REGISTER	ADDRESS	R/W	DESCRIPTION	RESET VALUE
PS2CMD	0xFFF8_9000	R/W	PS2 Host Controller Command Register	0x0000_0000
PS2STS	0xFFF8_9004	R/W	PS2 Host Controller Status Register	0x0000_0000
PS2SCANCODE	0xFFF8_9008	RO	PS2 Host Controller RX Scan Code Register	0x0000_0000
PS2ASCII	0xFFF8_900C	RO	PS2 Host Controller RX ASCII Code Register	0x0000_0000

6.2.2.2 Register Description

PS2 Host Controller Command Register (PS2_CMD)

REGISTER	ADDRESS	R/W	DESCRIPTION	RESET VALUE
PS2CMD	0xFFF8_9000	R/W	Command register	0x0000_0000

31	30	29	28	27	26	25	24
RESERVED							
23	22	21	20	19	18	17	16
RESERVED							
15	14	13	12	11	10	9	8
RESERVED						TRAP_SHIFT	EnCMD
7	6	5	4	3	2	1	0
PS2CMD							

BITS	DESCRIPTIONS	
[31:10]	RESERVED	-
[9]	TRAP_SHIFT	<p>Trap Shift Key Output to Scan Code Register</p> <p>If the host receives the shift key scan code (0x12 Or 0x59), software can indicate to the host if a scan code register update is required. No ASCII or SCAN codes are reported for the shift keys if this bit is set. In this condition, host will only report the shift keys at the RX_shift_key bit of Status register and no interrupt will occur for the shift keys. This is useful for those who wish to use the ASCII data stream and don't want to "manually" filter out the shift key codes. This bit is cleared by default.</p>

W90P710CD/W90P710CDG



Continued

BITS	DESCRIPTIONS	
[8]	EnCMD	<p>Enable write PS2 Host Controller Commands</p> <p>This bit enables the write function of Host controller command to device. Set this bit will start the write process of PS2CMD content and hardware will automatically clear this bit while write process is finished.</p>
[7:0]	PS2CMD	<p>PS2 Host Controller Commands</p> <p>This command file is sent from the host to the Keyboard. The most common command is setting/resetting the Status Indicators (i.e. the Num lock, Caps Lock & Scroll Lock LEDs).</p>

PS2 Host Controller Status Register (PS2_STS)

REGISTER	ADDRESS	R/W	DESCRIPTION	RESET VALUE
PS2STS	0xFFF8_9004	R/W	Status register	0x0000_0000

31	30	29	28	27	26	25	24
RESERVED							
23	22	21	20	19	18	17	16
RESERVED							
15	14	13	12	11	10	9	8
RESERVED							
7	6	5	4	3	2	1	0
RESERVED		TX_err	TX_IRQ	RESERVED			RX_IRQ

BITS	DESCRIPTIONS	
[31:6]	RESERVED	-
[5]	TX_err	<p>The Transmit Error Status bit indicates software that device doesn't response ACK after the host wrote a command to it.</p> <p>This bit is valid when TX_IRQ is asserted. It automatically resets after the software starts the next command writing process. This bit is read only.</p>
[4]	TX_IRQ	<p>The Transmit Complete Interrupt bit indicates the host controller write-to-device command is finished. Software needs to write logic 1 to this bit to clear the interrupt.</p>

W90P710CD/W90P710CDG



Continued

BITS	DESCRIPTIONS	
[3:1]	-	Reserved
[0]	RX_IRQ	The Receive Interrupt bit indicates the host controller received one byte of data from the device. This data is stored at PS2_SCANCODE register. The software needs to write 1 to this bit to clear the interrupt after receiving data in the RX_SCAN_CODE register. Note that the reception of the Extend (0xE0) and Release (0xF0) scan code does not trigger a host interrupt. Shift key codes are determined by the TRAP_SHIFT bit of the PS2_CMD register.

PS2 Host Controller RX Scan Code Register (PS2_SCANCODE)

REGISTER	ADDRESS	R/W	DESCRIPTION	RESET VALUE
PS2SCANCODE	0xFFFF_9008	R/W	RX Scan Code Register	0x0000_0000

31	30	29	28	27	26	25	24
RESERVED							
23	22	21	20	19	18	17	16
RESERVED							
15	14	13	12	11	10	9	8
RESERVED					RX_shift_key	RX_release	RX_extend
7	6	5	4	3	2	1	0
RX_SCAN_CODE							

BITS	DESCRIPTIONS	
[31:11]	RESERVED	-
[10]	RX_shift_key	The Receive Shift Key bit indicates the left or right shift key on the keyboard is held. This bit is read only and is cleared by the host when the release shift key codes are received.
[9]	RX_release	Receive Released Byte When a key is released, the keyboard sends F0 (hex) to inform the host controller. This bit indicates the host controller received the release byte (F0). This bit is read only and updates when the host has received the next data byte.



Continued

BITS	DESCRIPTIONS	
[8]	RX_extend	Receive Extended Byte A handful of keys on keyboard are extended keys and thus require two more scan codes. These keys are preceded by E0 (hex). This bit indicates the host controller received an extended byte (E0). This bit is read only and updates when the host has received the next data byte.
[7:0]	RX_SCAN_CODE	PS2 Host Controller Received Data Field This field stores the original data content transmitted from the device. This field is valid when RX_IRQ is asserted. Note that the host does not report "Extend" or "Release" scan codes to this field and does not generate interrupts if they are received by host, i.e. 0xE0 and 0xF0. The case of the shift key codes is determined by the TRAP_SHIFT bit of PS2_CMD register.

PS2 Host Controller RX ASCII Code Register (PS2_ASCII)

REGISTER	ADDRESS	R/W	DESCRIPTION	RESET VALUE
PS2ASCII	0xFFF8_900C	R/W	RX ASCII Code Register	0x0000_0000

31	30	29	28	27	26	25	24
RESERVED							
23	22	21	20	19	18	17	16
RESERVED							
15	14	13	12	11	10	9	8
RESERVED							
7	6	5	4	3	2	1	0
RX_ASCII_CODE							

BITS	DESCRIPTIONS	
[31:8]	RESERVED	-
[7:0]	RX_ASCII_CODE	PS2 Host Controller Received Data Field This field stores the ASCII data content transmitted from device. Therefore, this part translates the scan code into an ASCII value. It is read as 0x2E when there is no ASCII code mapped to the scan code stored in RX_SCAN_CODE register. This field is valid when RX_IRQ is asserted.

W90P710CD/W90P710CDG



7. ELECTRICAL SPECIFICATIONS

7.1 Absolute Maximum Ratings

Ambient temperature	-40 °C ~ +85°C
Storage temperature	-50 °C ~ +125°C
Voltage on any pin	-0.5V ~ 6V
Power supply voltage (Core logic)	-0.5V ~ 1.92V
Power supply voltage (IO Buffer)	-0.5V ~ 3.6V
Injection current (latch-up testing)	100mA
Crystal Frequency	4MHz ~ 30MHz

7.2 DC Specifications

7.2.1 Digital DC Characteristics

(Normal test conditions: VDD33/USBVDD = 3.3V+/- 0.3V, VDD18/DVDD18/AVDD18 = 1.8V+/- 0.18V

TA = -40 °C ~ +85 °C unless otherwise specified)

SYMBOL	PARAMETER	CONDITION	MIN.	MAX.	UNIT
VDD33/ USB1VDD USB2VDD	Power Supply		3.00	3.60	V
VDD18/ DVDD18/ AVDD18/ RTCVDD18	Power Supply		1.62	1.98	V
V _{IL}	Input Low Voltage		-0.3	0.8	V
V _{IH}	Input High Voltage		2.0	5.5	V
V _{T+}	Schmitt Trigger positive-going threshold		1.47	1.5	V
V _{T-}	Schmitt trigger negative-going threshold		0.89	0.95	V
V _{OL}	Output Low Voltage	Depend on driving	-	0.4	V
V _{OH}	Output High Voltage	Depend on driving	2.4	-	V
I _{CC1}	1.8V Supply Current	F _{CPU} = 80MHz	-	150	mA
I _{CC2}	3.3V Supply Current	F _{CPU} = 80MHz	-	60	mA
I _{CCRTC}	RTC 1.8V Supply Current	F _{RTC} = 32.768KHZ	-	7	uA
I _{IH}	Input High Current	V _{IN} = 2.4 V	-1	1	μA
I _{IL}	Input Low Current	V _{IN} = 0.4 V	-1	1	μA
I _{IHP}	Input High Current (pull-up)	V _{IN} = 2.4 V	-15	-10	μA
I _{ILP}	Input Low Current (pull-up)	V _{IN} = 0.4 V	-55	-25	μA
I _{IHD}	Input High Current (pull-down)	V _{IN} = 2.4 V	25	60	μA
I _{ILD}	Input Low Current (pull-down)	V _{IN} = 0.4 V	5	10	μA

W90P710CD/W90P710CDG



Table 7.2.1TSMC IO DC Characteristics

PARAMETER		MIN.	TYP.	MAX.
V_{IL}	Input Low Voltage	-0.3V		0.8V
V_{IH}	Input High Voltage	2V		5.5V
V_T	Threshold point	1.46V	1.59V	1.75V
V_{T+}	Schmitt trig low to high threshold point	1.47V	1.50V	1.50V
V_{T-}	Schmitt trig, high to low threshold point	0.90V	0.94V	0.96V
I_I	Input leakage current @V _I = 3.3V or 0V			+/- 10uA
I_{oz}	Tri-state output leakage current @V _o =3.3V or 0V			+/- 10UA
R_{PU}	Pull-up resistor	44KΩ	66KΩ	110KΩ
R_{PD}	Pull-down resistor	25KΩ	50KΩ	110KΩ
V_{OL}	Output low voltage @I _{OL} (min)			0.4V
V_{OH}	Output high voltage @I _{OH} (min)	2.4V		
I_{OL}	Low level output current @V _{OL} = 0.4V 4mA	4.9mA	7.4mA	9.8mA
	Low level output current @V _{OL} = 0.4V 8mA	9.7mA	14.9mA	19.5mA
	Low level output current @V _{OL} = 0.4V 12mA	14.6mA	22.3mA	29.3mA
I_{OH}	High level output current @V _{OH} = 2.4V 4mA	6.3mA	12.8mA	21.2mA
	High level output current @V _{OH} = 2.4V 8mA	12.7mA	25.6mA	42.4mA
	High level output current @V _{OH} = 2.4V 12mA	19.0mA	38.4mA	63.6mA
NOTE: The values in this table are copied from TSMC 1P5M IO library tpz937g_240b silicon report. This table is just for reference. For a more precise DC value, refer to the Alpha-Test result.				

W90P710CD/W90P710CDG



7.2.2 USB Transceiver DC Characteristics

SYMBOL	PARAMETER	CONDITIONS	MIN.	MAX.	UNIT
V_{DI}	Differential Input Sensitivity	$ DP - DM $	0.2		V
V_{CM}	Differential Common Mode Range	Includes V_{DI} range	0.8	2.5	V
V_{SE}	Single Ended Receiver Threshold		0.8	2.0	V
V_{OL}	Static Output Low Voltage	RL of 1.5 K Ω to 3.6 V		0.3	V
V_{OH}	Static Output High Voltage	RL of 15 K Ω to VSS	2.8	3.6	V
V_{CRS}	Output Signal Crossover Voltage		1.3	2.0	V
Z_{DRV}	Driver Output Resistance	Steady state drive	28	43	Ω
C_{IN}	Pin Capacitance			20	pF

7.3 AC Specifications

7.3.1 EB/SDRAM Interface AC Characteristics

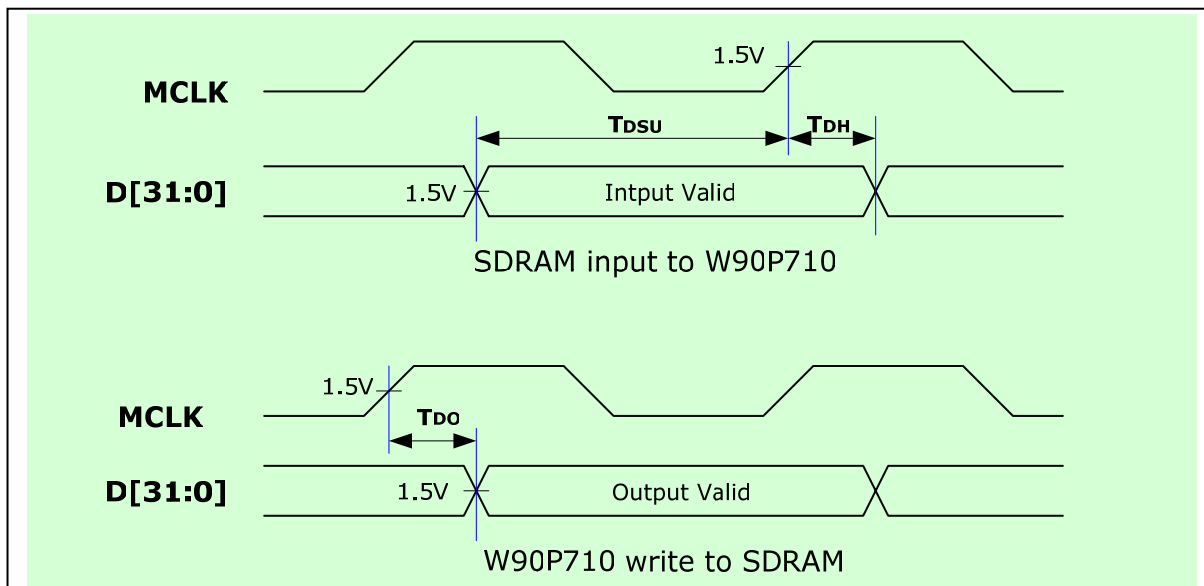

SYMBOL	PARAMETER	MIN.	MAX.	UNIT
T_{DSU}	D [31:0] Setup Time	2		ns
T_{DH}	D [31:0] Hold Time	2		ns
T_{DO}	D [31:0], A [24:0], nSCS [1:0], SDQM [3:0], CKE, nSWE, nSRAS, nSCAS	2	7	ns



7.3.2 EBI(ROM/SRAM/External I/O) AC Characteristics

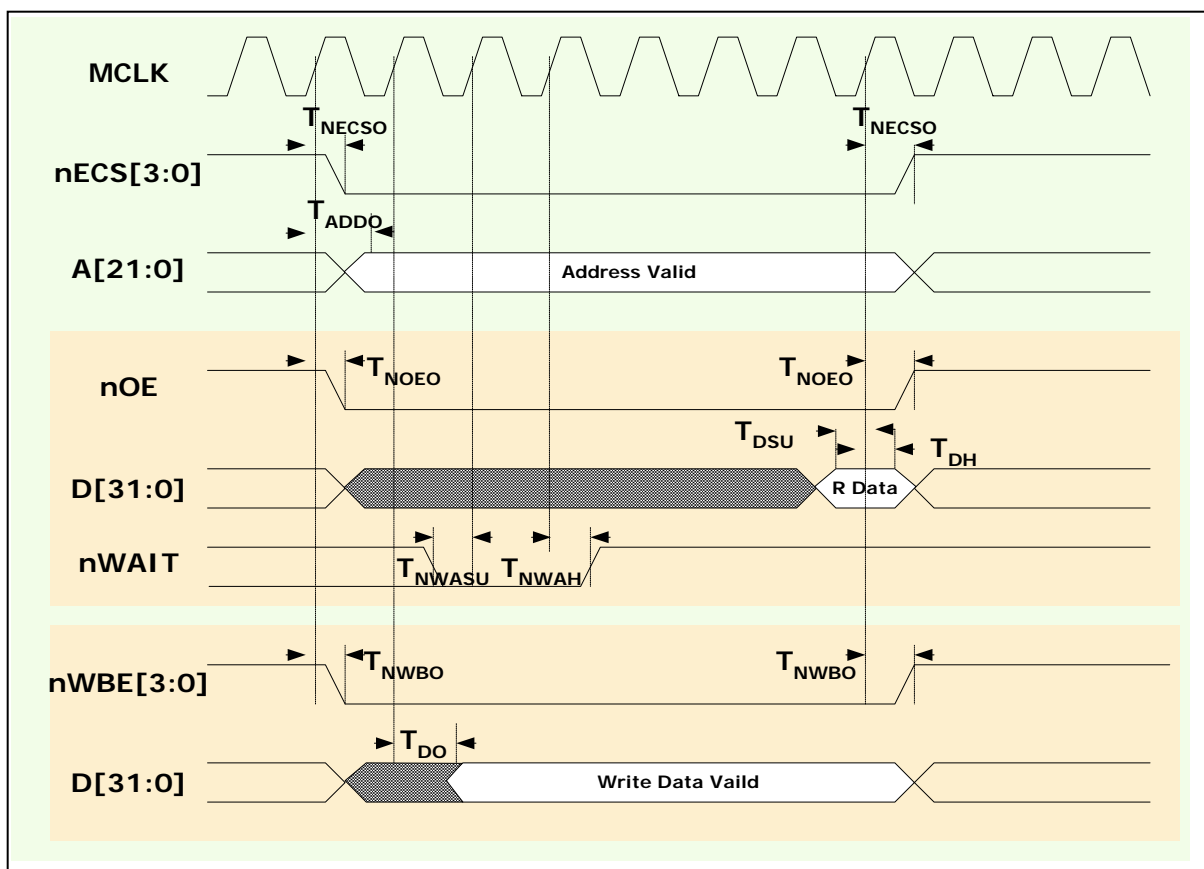

SYMBOL	DESCRIPTION	MIN	MAX	UNIT
T_{ADD0}	Address Output Delay Time	2	7	ns
T_{NCS0}	ROM/SRAM/Flash or External I/O Chip Select Delay Time	2	7	ns
T_{NOEO}	ROM/SRAM or External I/O Bank Output Enable Delay	2	7	ns
T_{NWBO}	ROM/SRAM or External I/O Bank Write Byte Enable Delay	2	7	ns
T_{DH}	Read Data Hold Time	7		ns
T_{DSU}	Read Data Setup Time	0		ns
T_{DO}	Write Data Output Delay Time (SRAM or External I/O)	2	7	ns
T_{NWASU}	External Wait Setup Time	3		ns
T_{NWAH}	External Wait Hold Time	1		ns

W90P710CD/W90P710CDG



7.3.3 USB Transceiver AC Characteristics

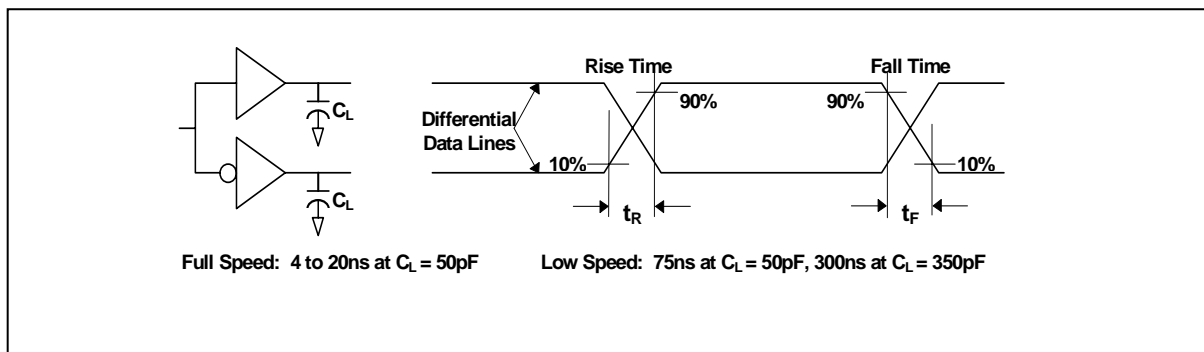

Data Signal Rise and Fall Time

USB Transceiver AC Characteristics

SYMBOL	DESCRIPTION	CONDITIONS	MIN	MAX	UNIT
T_R	Rise Time	$C_L = 50 \text{ pF}$	4	20	ns
T_F	Fall Time	$C_L = 50 \text{ pF}$	4	20	ns
T_{RFM}	Rise/Fall Time Matching		90	110	%
T_{DRATE}	Full Speed Data Rate	Average bit rate (12 Mb/s \pm 0.25%)	11.97	12.03	Mbps



7.3.4 EMC RMI AC Characteristics

Signal timing characteristics conforms to guidelines specified in IEEE Std. 802.3.

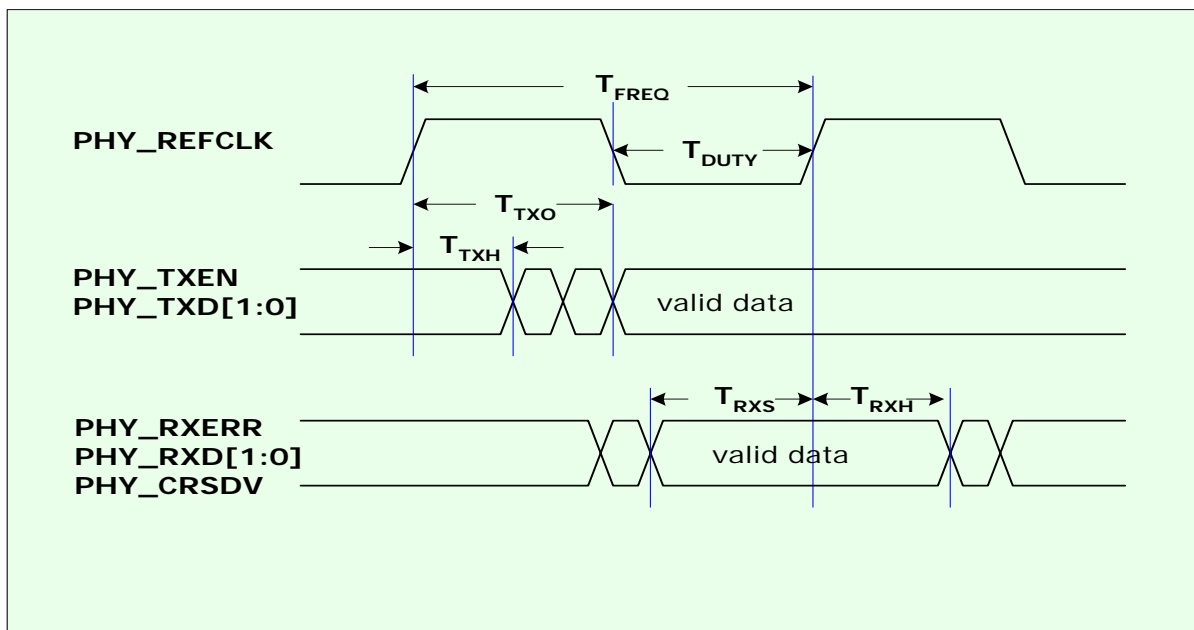

SYMBOL	DESCRIPTION	MIN	TYP	MAX	UNIT
T_{FREQ}	RMI reference clock frequency		50		MHz
T_{DUTY}	RMI clock duty	35%	50%	65%	ns
T_{TXO}	Transmit data output delay	5	-	15	ns
T_{TXH}	Transmit data hold time	2	-	-	ns
T_{RXS}	Receive data setup time	4	-	-	ns
T_{RXH}	Receive data hold time	2	-	-	ns

W90P710CD/W90P710CDG

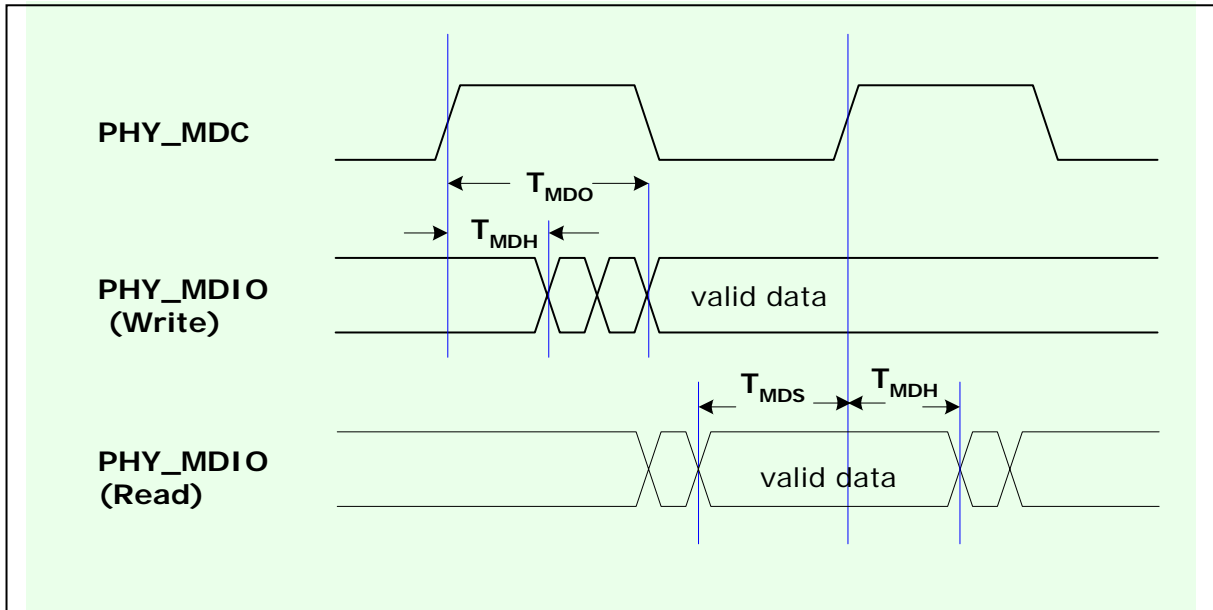

SYMBOL	DESCRIPTION	MIN	MAX	UNIT
T_{MDO}	MDIO Output Delay Time	0	15	ns
T_{MDSU}	MDIO Setup Time	5		ns
T_{MDH}	MDIO Hold Time	5		ns

W90P710CD/W90P710CDG



7.3.5 LCD Interface AC Characteristics

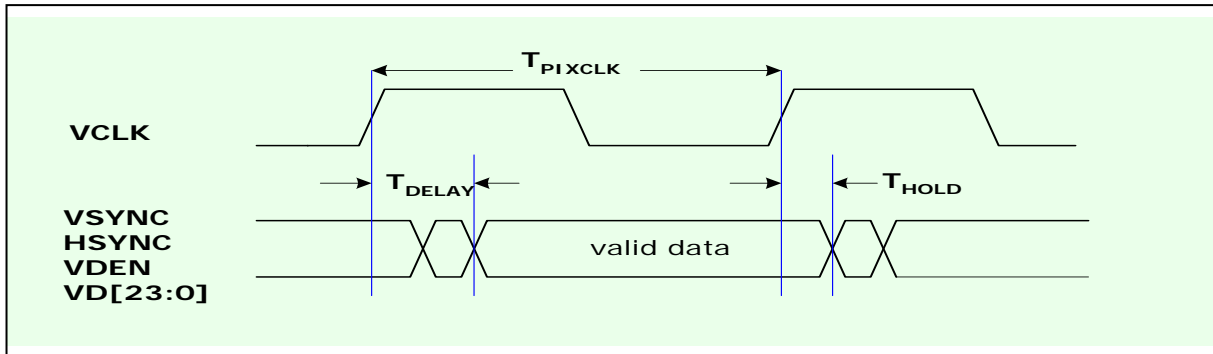

SYMBOLS	DESCRIPTION	MIN	MAX	UNIT
T_{PIXCLK}	Pixel clock frequency	-	40	MHz
T_{DELAY}	VSYNC, HSYNC, VDEN and VD [23:0] output delay from VCLK rising edge	5	15	ns
T_{HOLD}	VSYNC, HSYNC, VDEN and VD [23:0] output data hold time from VCLK rising edge	0	5	ns



7.3.6 SD Interface AC Characteristics

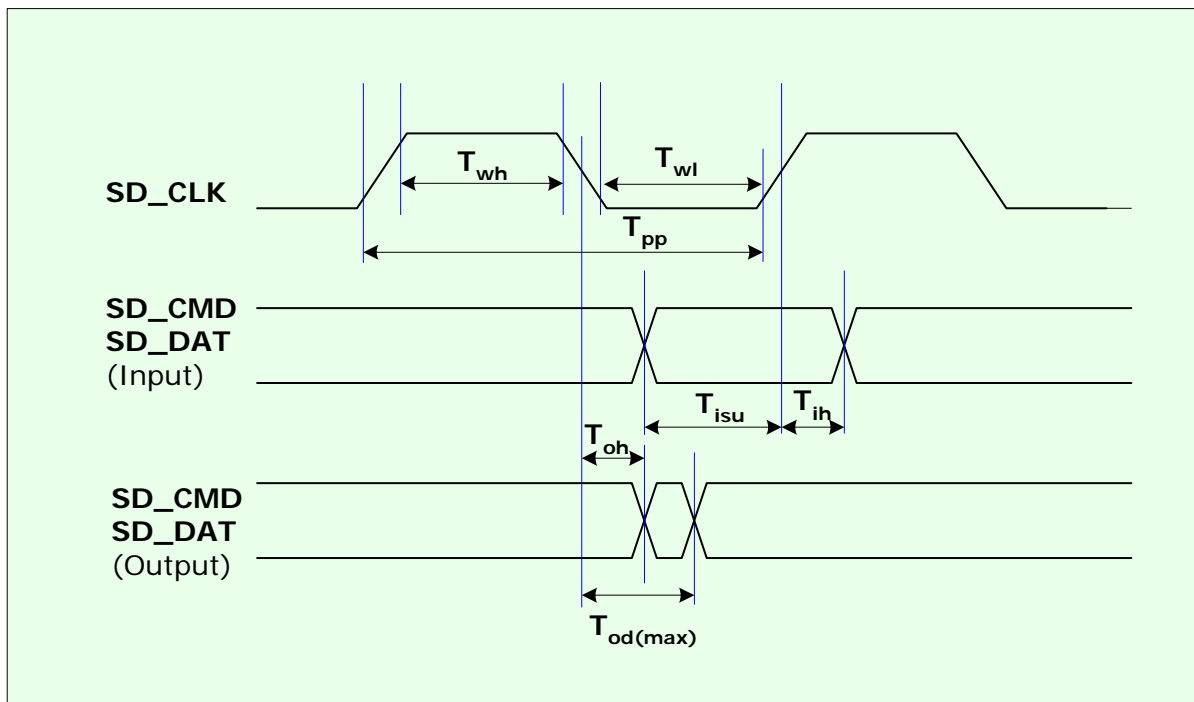

SYMBOLS	DESCRIPTION	MIN.	TYP.	MAX.	UNIT
T_{pp}	SD Clock Frequency	--	--	20	MHz
T_{wh}	SD Clock High Time	10	--	--	ns
T_{wl}	SD Clock Low Time	10	--	--	ns
Input CMD, DAT (reference to SD_CLK rising edge)					
T_{isu}	Input Setup Time	5	--	--	ns
T_{ih}	Input Hold Time	5	--	--	ns
Output CMD, DAT (reference to SD_CLK falling edge)					
T_{od}	Output Delay Time	0	--	14	ns



7.3.7 AC97/I2S Interface AC Characteristics

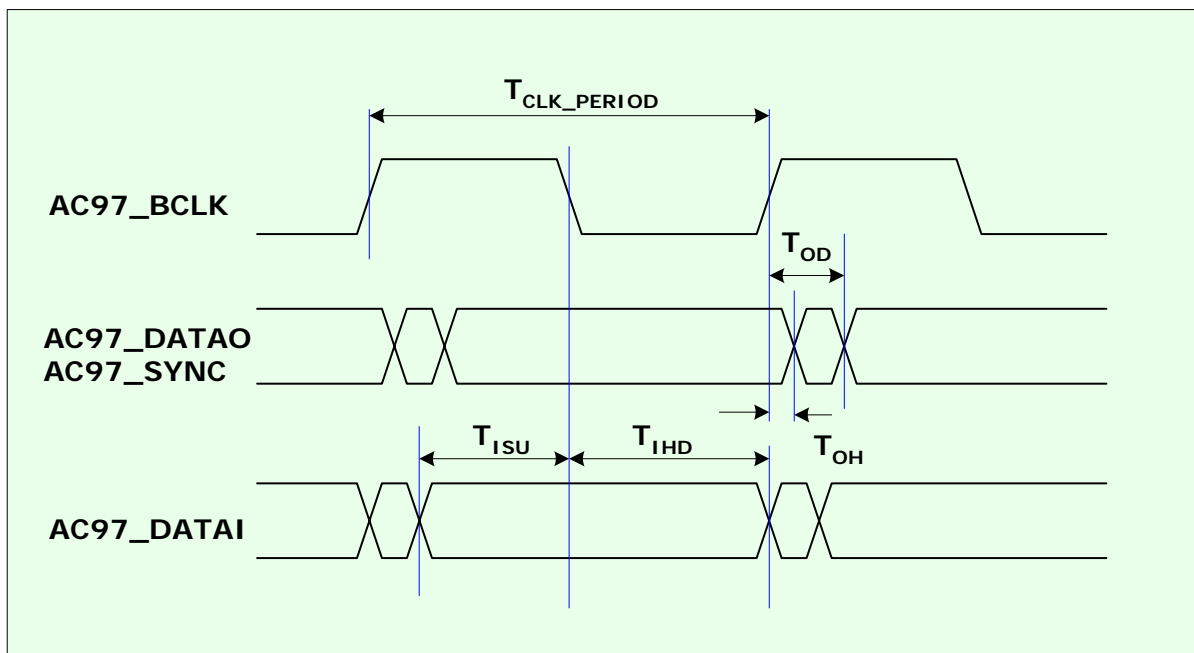

SYMBOLS	DESCRIPTION	MIN	TYP.	MAX	UNIT
T_{CLK_PERIOD}	AC97 Bit Clock Frequency	--	12.288	--	MHz
T_{OD}	AC97_DATAO and AC97_SYNC output delay from AC97_BCLK rising edge	--	--	30	ns
T_{OH}	AC97_DATAO and AC97_SYNC output hold time from AC97_BCLK rising edge	5	--	--	ns
T_{ISU}	AC97_DATAI input setup time to AC97_BCLK falling edge	10	--	--	ns
T_{IHD}	AC97_DATAI input hold time from AC97_BCLK falling edge	5	--	--	ns

W90P710CD/W90P710CDG

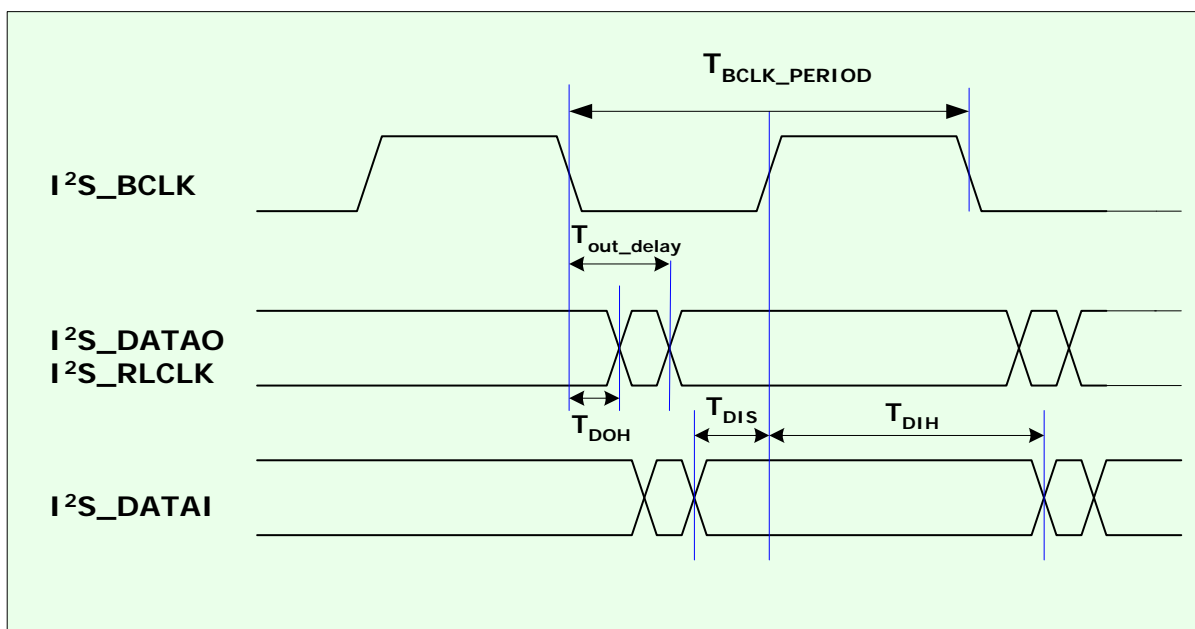

SYMBOLS	DESCRIPTION	MIN	MAX	UNIT
T _{BCLK_PERIOD}	IIS Bit Clock Frequency	Note: depending on codec specifications and register settings		MHz
T _{out_delay}	IIS_DATAO and IIS_RLCLK output delay from IIS_BCLK falling edge	--	30	ns
T _{DOH}	IIS_DATAO and IIS_RLCLK data output hold time from IIS_BCLK falling edge	0	--	ns
T _{DIS}	IIS_DATAI input setup time to IIS_BCLK rising edge	10	--	ns
T _{DIH}	IIS_DATAI input hold time from IIS_BCLK rising edge	100	--	ns



7.3.8 Smart Card Interface AC Characteristics

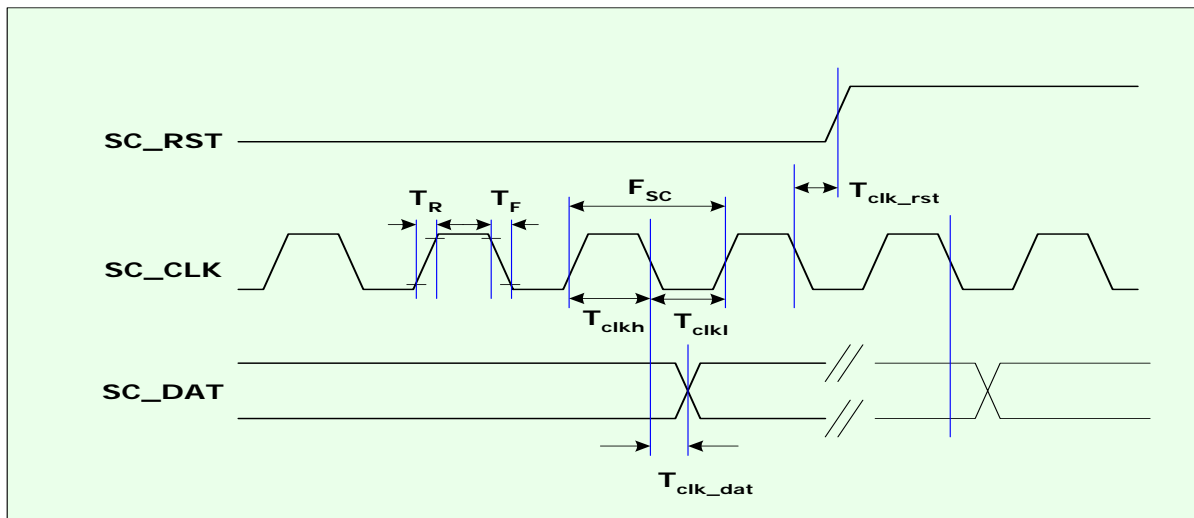

SYMBOL	DESCRIPTION	CONDITION	MIN	TYP	MAX	UNIT
T_R and T_F for RST	Rising and falling time of RST signal	CL = 30pF (Max)			0.8	us
T_R and T_F for CLK	Rising and falling time of CLK signal	CL = 30pF (Max)	4		8% of clock period	
T_R and T_F for DAT (Transmit)	Rising and falling time of DAT signal in transmission mode	CL = 30pF (Max)			0.8	us
T_R and T_F for DAT (Receive)	Rising and falling time of DAT signal in receive mode				1.2	us
F_{sc}	Smart card clock frequency		1	2.5	20	MHz
T_{clkh}	Smart card clock high time		40%	50%	60%	clock
T_{clkl}	Smart card clock low time		40%	50%	60%	clock
T_{clk_dat}	DAT output delay from SC_CLK falling edge		5	-	20	ns
T_{clk_rst}	RST output delay from SC_CLK falling edge		5	-	10	ns



7.3.9 I2C Interface AC Characteristics

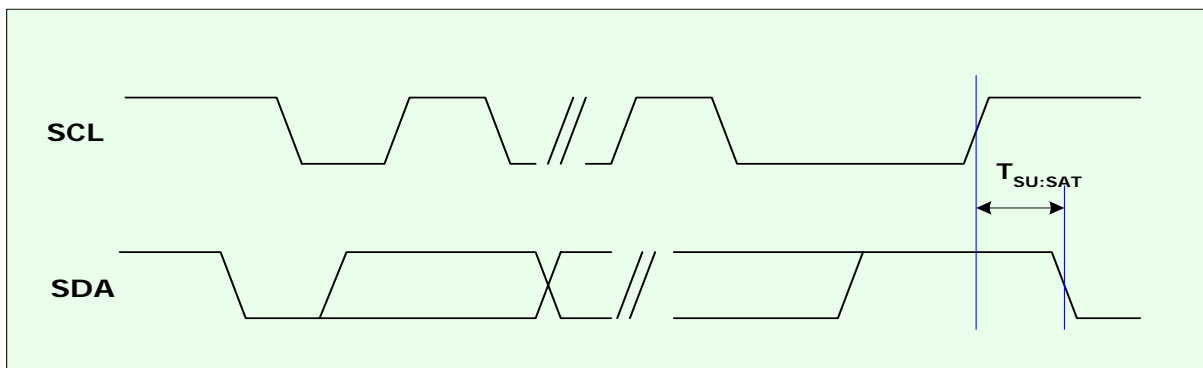
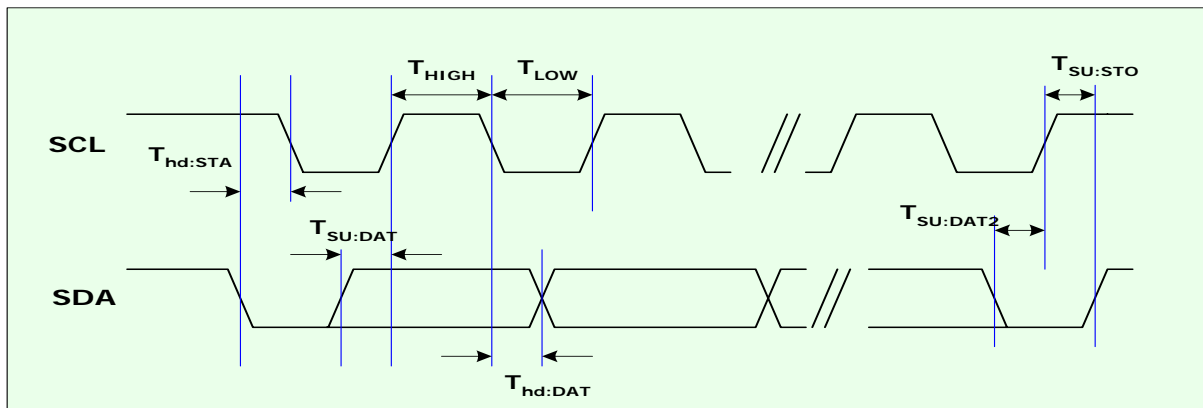

SYMBOL	DESCRIPTION	MIN	MAX	UNIT
T_{HIGH}	I ² C Clock high time	1	-	us
T_{LOW}	I ² C clock low time	1	-	us
$T_{hd:STA}$	Start condition hold time	1	-	us
$T_{SU:DAT}$	Receive data setup time	0.1	-	us
	Transmit data output delay	-	0.5	us
$T_{HD:DAT}$	Receive data hold time	1	-	us
	Transmit data hold time	0	0.9	us
$T_{SU:DAT2}$	SDA setup time (before STOP condition)	0.5	-	us
$T_{SU:STO}$	Stop condition setup time	1	-	us
$T_{SU:STA}$	Restart condition setup time	1.5	-	us



7.3.10 USI Interface AC Characteristics

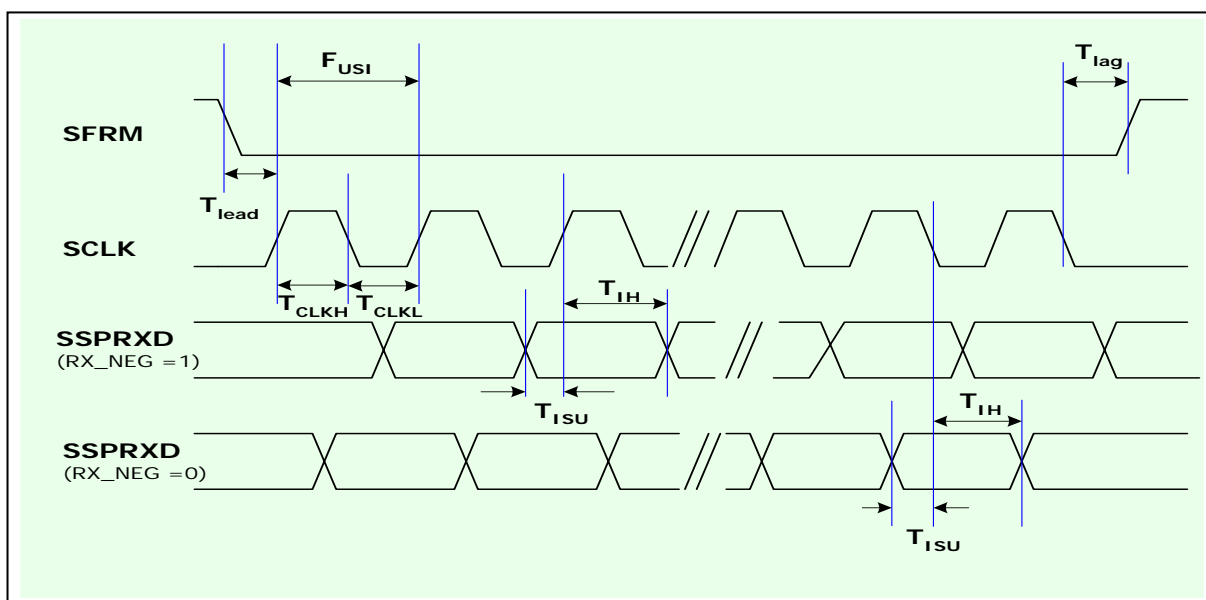
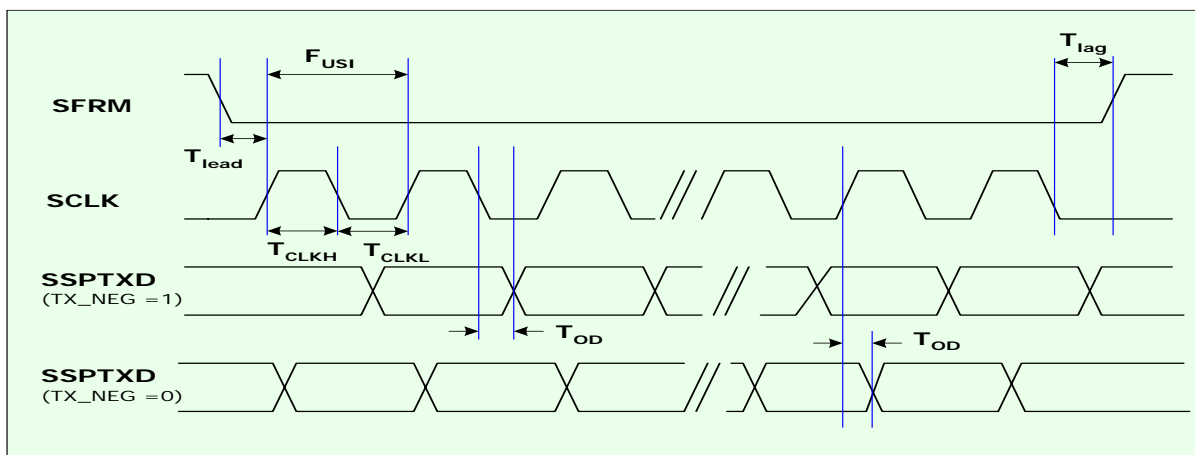

SYMBOL	DESCRIPTION	MIN	MAX	UNIT
F_{USI}	USI clock frequency	-	20	MHz
T_{CLKH}	USI clock high time	12.5	-	ns
T_{CLKL}	USI clock low time	-	-	ns
T_{ISU}	Data input setup time	-	14	ns
T_{IH}	Data input hold time	0	-	ns
T_{lead}	USI enable lead time	12.5	-	ns
T_{lag}	USI enable lag time	12.5	-	ns
T_{OD}	USI output data valid time	-	30	ns



7.3.11 PS2 Interface AC Characteristics

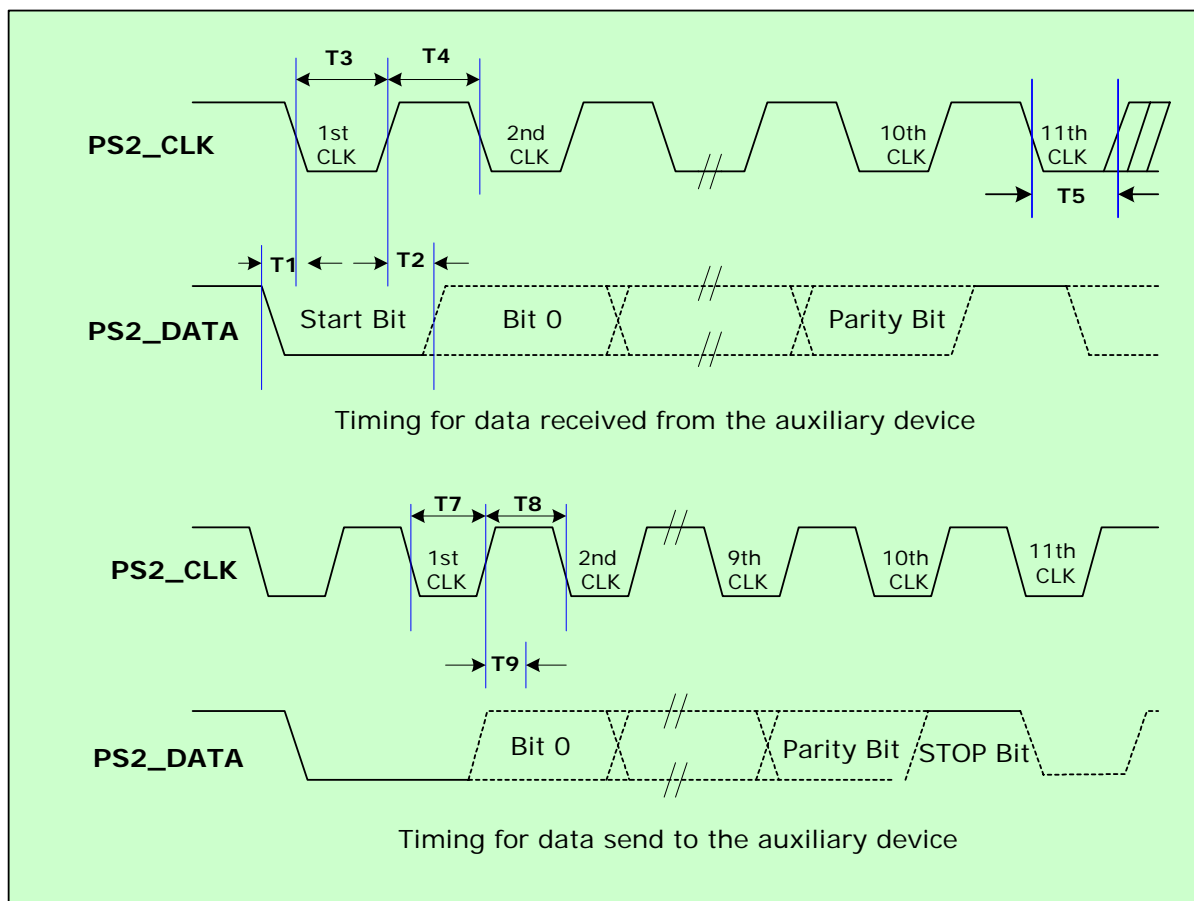

SYMBOL	DESCRIPTION	MIN.	MAX.	UNIT
T1	Time from DATA transition to falling edge of CLK	5	25	us
T2	Time form rising edge of CLK to DATA transition	5	T4-5	us
T3	Duration of CLK inactive	30	50	us
T4	Duration of clock active	30	50	us
T5	Time to auxiliary device inhibit after clock 11 to ensure the auxiliary device does not start another transmission	0	50	us
T7	Duration of CLK inactive	30	50	us
T8	Duration of CLK active	30	50	us
T9	Time from inactive to active CLK transition, used to time when the auxiliary device samples DATA	30	50	us

W90P710CD/W90P710CDG



8. ORDERING INFORMATION

PART NUMBER	NAME	PACKAGE DESCRIPTION
W90P710CD	LQFP176	176 Leads, body 22 x 22 x 1.4 mm
W90P710CDG	LQFP176	176 Leads, body 22 x 22 x 1.4 mm, Lead free package

W90P710CD/W90P710CDG



9. PACKAGE SPECIFICATIONS

176L LQFP (20X20X1.4 mm footprint 2.0mm)

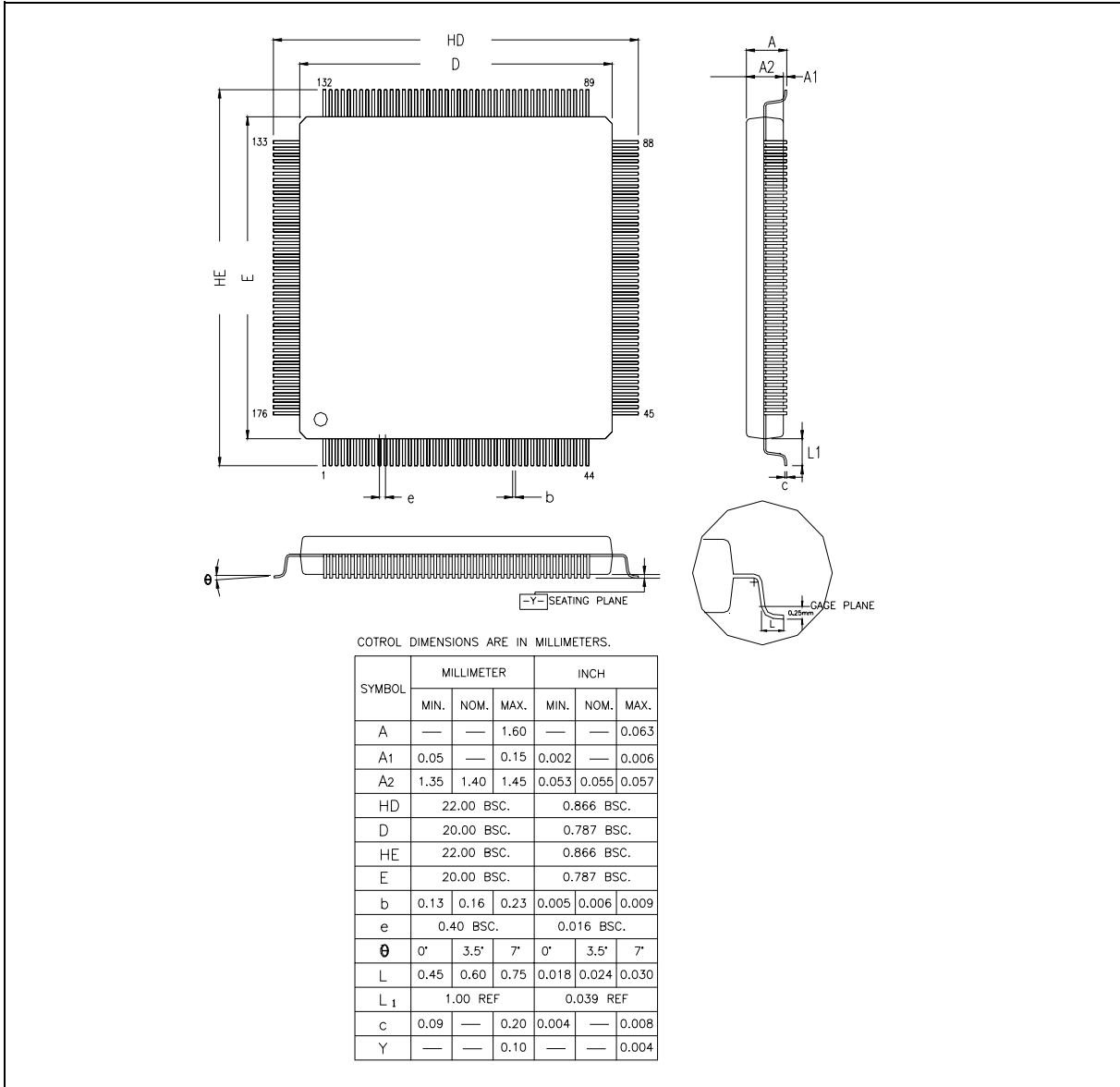

W90P710CD/W90P710CDG



10. APPENDIX A: W90P710 REGISTERS MAPPING TABLE

R: read only, W: write only, R/W: both read and write, C: Only value 0 can be written

System Manager Control Registers Map

REGISTER	ADDRESS	R/W	DESCRIPTION	RESET VALUE
PDID	0xFFFF0_0000	R	Product Identifier Register	0xX090.0710
ARBCON	0xFFFF0_0004	R/W	Arbitration Control Register	0x0000_0000
PLLCON	0xFFFF0_0008	R/W	PLL Control Register	0x0000_2F01
CLKSEL	0xFFFF0_000C	R/W	Clock Select Register	0x1FFF_3FX8
PLLCON1	0xFFFF0_0010	R/W	PLL Control Register 2	0x0001_0000
I2SCKCON	0xFFFF0_0014	R/W	Audio IIS Clock Control Register	0x0000_0000
IRQWAKECON	0xFFFF0_0020	R/W	IRQ Wakeup Control register	0x0000_0000
IRQWAKEFLAG	0xFFFF_0024	R/W	IRQ wakeup Flag Register	0x0000_0000
PMCON	0xFFFF0_0028	R/W	Power Manager Control Register	0x0000_0000
USBTxrCON	0xFFFF0_0030	R/W	USB Transceiver Control Register	0x0000_0000

External Bus Interface Control Registers Map

REGISTER	ADDRESS	R/W	DESCRIPTION	RESET VALUE
EBICON	0xFFFF0_1000	R/W	EBI control register	0x0001_0000
ROMCON	0xFFFF0_1004	R/W	ROM/FLASH control register	0x0000_0XFC
SDCONF0	0xFFFF0_1008	R/W	SDRAM bank 0 configuration register	0x0000_0800
SDCONF1	0xFFFF0_100C	R/W	SDRAM bank 1 configuration register	0x0000_0800
SDTIME0	0xFFFF0_1010	R/W	SDRAM bank 0 timing control register	0x0000_0000
SDTIME1	0xFFFF0_1014	R/W	SDRAM bank 1 timing control register	0x0000_0000
EXT0CON	0xFFFF0_1018	R/W	External I/O 0 control register	0x0000_0000
EXT1CON	0xFFFF0_101C	R/W	External I/O 1 control register	0x0000_0000
EXT2CON	0xFFFF0_1020	R/W	External I/O 2 control register	0x0000_0000
EXT3CON	0xFFFF0_1024	R/W	External I/O 3 control register	0x0000_0000
CKSKEW	0xFFFF0_1F00	R/W	Clock skew control register (for testing)	0xXXXX_0038

W90P710CD/W90P710CDG



Cache Control Registers Map

REGISTER	ADDRESS	R/W	DESCRIPTION	RESET VALUE
CAHCNF	0xFFFF0_2000	R/W	Cache configuration register	0x0000_0000
CAHCON	0xFFFF0_2004	R/W	Cache control register	0x0000_0000
CAHADR	0xFFFF0_2008	R/W	Cache address register	0x0000_0000

EMC Registers Map

REGISTER	ADDRESS	R/W	DESCRIPTION	RESET VALUE
CAMCMR	0xFFFF0_3000	R/W	CAM Command Register	0x0000_0000
CAMEN	0xFFFF0_3004	R/W	CAM Enable Register	0x0000_0000
CAM0M	0xFFFF0_3008	R/W	CAM0 Most Significant Word Register	0x0000_0000
CAM0L	0xFFFF0_300C	R/W	CAM0 Least Significant Word Register	0x0000_0000
CAM1M	0xFFFF0_3010	R/W	CAM1 Most Significant Word Register	0x0000_0000
CAM1L	0xFFFF0_3014	R/W	CAM1 Least Significant Word Register	0x0000_0000
CAM2M	0xFFFF0_3018	R/W	CAM2 Most Significant Word Register	0x0000_0000
CAM2L	0xFFFF0_301C	R/W	CAM2 Least Significant Word Register	0x0000_0000
CAM3M	0xFFFF0_3020	R/W	CAM3 Most Significant Word Register	0x0000_0000
CAM3L	0xFFFF0_3024	R/W	CAM3 Least Significant Word Register	0x0000_0000
CAM4M	0xFFFF0_3028	R/W	CAM4 Most Significant Word Register	0x0000_0000
CAM4L	0xFFFF0_302C	R/W	CAM4 Least Significant Word Register	0x0000_0000
CAM5M	0xFFFF0_3030	R/W	CAM5 Most Significant Word Register	0x0000_0000
CAM5L	0xFFFF0_3034	R/W	CAM5 Least Significant Word Register	0x0000_0000
CAM6M	0xFFFF0_3038	R/W	CAM6 Most Significant Word Register	0x0000_0000
CAM6L	0xFFFF0_303C	R/W	CAM6 Least Significant Word Register	0x0000_0000
CAM7M	0xFFFF0_3040	R/W	CAM7 Most Significant Word Register	0x0000_0000
CAM7L	0xFFFF0_3044	R/W	CAM7 Least Significant Word Register	0x0000_0000
CAM8M	0xFFFF0_3048	R/W	CAM8 Most Significant Word Register	0x0000_0000
CAM8L	0xFFFF0_304C	R/W	CAM8 Least Significant Word Register	0x0000_0000
CAM9M	0xFFFF0_3050	R/W	CAM9 Most Significant Word Register	0x0000_0000
CAM9L	0xFFFF0_3054	R/W	CAM9 Least Significant Word Register	0x0000_0000
CAM10M	0xFFFF0_3058	R/W	CAM10 Most Significant Word Register	0x0000_0000
CAM10L	0xFFFF0_305C	R/W	CAM10 Least Significant Word Register	0x0000_0000
CAM11M	0xFFFF0_3060	R/W	CAM11 Most Significant Word Register	0x0000_0000
CAM11L	0xFFFF0_3064	R/W	CAM11 Least Significant Word Register	0x0000_0000

W90P710CD/W90P710CDG



EMC Registers Map, continued

REGISTER	ADDRESS	R/W	DESCRIPTION	RESET VALUE
CAM12M	0xFFFF0_3068	R/W	CAM12 Most Significant Word Register	0x0000_0000
CAM12L	0xFFFF0_306C	R/W	CAM12 Least Significant Word Register	0x0000_0000
CAM13M	0xFFFF0_3070	R/W	CAM13 Most Significant Word Register	0x0000_0000
CAM13L	0xFFFF0_3074	R/W	CAM13 Least Significant Word Register	0x0000_0000
CAM14M	0xFFFF0_3078	R/W	CAM14 Most Significant Word Register	0x0000_0000
CAM14L	0xFFFF0_307C	R/W	CAM14 Least Significant Word Register	0x0000_0000
CAM15M	0xFFFF0_3080	R/W	CAM15 Most Significant Word Register	0x0000_0000
CAM15L	0xFFFF0_3084	R/W	CAM15 Least Significant Word Register	0x0000_0000
TXDLSA	0xFFFF0_3088	R/W	Transmit Descriptor Link List Start Address Register	0xFFFF_FFFC
RXDLSA	0xFFFF0_308C	R/W	Receive Descriptor Link List Start Address Register	0xFFFF_FFFC
MCMDR	0xFFFF0_3090	R/W	MAC Command Register	0x0000_0000
MIID	0xFFFF0_3094	R/W	MII Management Data Register	0x0000_0000
MIIDA	0xFFFF0_3098	R/W	MII Management Control and Address Register	0x0090_0000
FFTCCR	0xFFFF0_309C	R/W	FIFO Threshold Control Register	0x0000_0101
TSDR	0xFFFF0_30A0	W	Transmit Start Demand Register	Undefined
RSDR	0xFFFF0_30A4	W	Receive Start Demand Register	Undefined
DMARFC	0xFFFF0_30A8	R/W	Maximum Receive Frame Control Register	0x0000_0800
MIEN	0xFFFF0_30AC	R/W	MAC Interrupt Enable Register	0x0000_0000
MISTA	0xFFFF0_30B0	R/W	MAC Interrupt Status Register	0x0000_0000
MGSTA	0xFFFF0_30B4	R/W	MAC General Status Register	0x0000_0000
MPCNT	0xFFFF0_30B8	R/W	Missed Packet Count Register	0x0000_7FFF
MRPC	0xFFFF0_30BC	R	MAC Receive Pause Count Register	0x0000_0000
MRPCC	0xFFFF0_30C0	R	MAC Receive Pause Current Count Register	0x0000_0000
MREPC	0xFFFF0_30C4	R	MAC Remote Pause Count Register	0x0000_0000
DMARFS	0xFFFF0_30C8	R/W	DMA Receive Frame Status Register	0x0000_0000
CTXDSA	0xFFFF0_30CC	R	Current Transmit Descriptor Start Address Register	0x0000_0000
CTXBSA	0xFFFF0_30D0	R	Current Transmit Buffer Start Address Register	0x0000_0000
CRXDSA	0xFFFF0_30D4	R	Current Receive Descriptor Start Address Register	0x0000_0000
CRXBSA	0xFFFF0_30D8	R	Current Receive Buffer Start Address Register	0x0000_0000

W90P710CD/W90P710CDG



EMC Registers Map, continued

REGISTER	ADDRESS	R/W	DESCRIPTION	RESET VALUE
RXFSM	0xFFFF0_3200	R	Receive Finite State Machine Register	0x0081_1101
TXFSM	0xFFFF0_3204	R	Transmit Finite State Machine Register	0x0101_1101
FSM0	0xFFFF0_3208	R	Finite State Machine Register 0	0x0001_0101
FSM1	0xFFFF0_320C	R	Finite State Machine Register 1	0x1100_0100
DCR	0xFFFF0_3210	R/W	Debug Configuration Register	0x0000_003F
DMMIR	0xFFFF0_3214	R	Debug Mode MAC Information Register	0x0000_0000
BISTR	0xFFFF0_3300	R/W	BIST Mode Register	0x0000_0000

GDMA Register Map

REGISTER	ADDRESS	R/W	DESCRIPTION	RESET VALUE
GDMA_CTL0	0xFFFF0_4000	R/W	Channel 0 Control Register	0x0000_0000
GDMA_SRCB0	0xFFFF0_4004	R/W	Channel 0 Source Base Address Register	0x0000_0000
GDMA_DSTB0	0xFFFF0_4008	R/W	Channel 0 Destination Base Address Register	0x0000_0000
GDMA_TCNT0	0xFFFF0_400C	R/W	Channel 0 Transfer Count Register	0x0000_0000
GDMA_CSRC0	0xFFFF0_4010	R	Channel 0 Current Source Address Register	0x0000_0000
GDMA_CDST0	0xFFFF0_4014	R	Channel 0 Current Destination Address Register	0x0000_0000
GDMA_CTCNT0	0xFFFF0_4018	R	Channel 0 Current Transfer Count Register	0x0000_0000
GDMA_CTL1	0xFFFF0_4020	R/W	Channel 1 Control Register	0x0000_0000
GDMA_SRCB1	0xFFFF0_4024	R/W	Channel 1 Source Base Address Register	0x0000_0000
GDMA_DSTB1	0xFFFF0_4028	R/W	Channel 1 Destination Base Address Register	0x0000_0000
GDMA_TCNT1	0xFFFF0_402C	R/W	Channel 1 Transfer Count Register	0x0000_0000
GDMA_CSRC1	0xFFFF0_4030	R	Channel 1 Current Source Address Register	0x0000_0000
GDMA_CDST1	0xFFFF0_4034	R	Channel 1 Current Destination Address Register	0x0000_0000
GDMA_CTCNT1	0xFFFF0_4038	R	Channel 1 Current Transfer Count Register	0x0000_0000

W90P710CD/W90P710CDG



USB Host Controller Register Map

REGISTER	ADDRESS	R/W	DESCRIPTION	RESET VALUE
OpenHCI Registers				
HcRevision	0xFFFF0_5000	R	Host Controller Revision Register	0x0000_0010
HcControl	0xFFFF0_5004	R/W	Host Controller Control Register	0x0000_0000
HcCommandStatus	0xFFFF0_5008	R/W	Host Controller Command Status Register	0x0000_0000
HcInterruptStatus	0xFFFF0_500C	R/W	Host Controller Interrupt Status Register	0x0000_0000
HcInterruptEnable	0xFFFF0_5010	R/W	Host Controller Interrupt Enable Register	0x0000_0000
HcInterruptDisable	0xFFFF0_5014	R/W	Host Controller Interrupt Disable Register	0x0000_0000
HcHCCA	0xFFFF0_5018	R/W	Host Controller Communication Area Register	0x0000_0000
HcPeriodCurrentED	0xFFFF0_501C	R/W	Host Controller Period Current ED Register	0x0000_0000
HcControlHeadED	0xFFFF0_5020	R/W	Host Controller Control Head ED Register	0x0000_0000
HcControlCurrentED	0xFFFF0_5024	R/W	Host Controller Control Current ED Register	0x0000_0000
HcBulkHeadED	0xFFFF0_5028	R/W	Host Controller Bulk Head ED Register	0x0000_0000
HcBulkCurrentED	0xFFFF0_502C	R/W	Host Controller Bulk Current ED Register	0x0000_0000
HcDoneHeadED	0xFFFF0_5030	R/W	Host Controller Done Head Register	0x0000_0000
HcFmInterval	0xFFFF0_5034	R/W	Host Controller Frame Interval Register	0x0000_2EDF
HcFrameRemaining	0xFFFF0_5038	R	Host Controller Frame Remaining Register	0x0000_0000
HcFmNumber	0xFFFF0_503C	R	Host Controller Frame Number Register	0x0000_0000
HcPeriodicStart	0xFFFF0_5040	R/W	Host Controller Periodic Start Register	0x0000_0000
HcLSThreshold	0xFFFF0_5044	R/W	Host Controller Low Speed Threshold Register	0x0000_0628
HcRhDescriptorA	0xFFFF0_5048	R/W	Host Controller Root Hub Descriptor A Register	0x0100_0002
HcRhDescriptorB	0xFFFF0_504C	R/W	Host Controller Root Hub Descriptor B Register	0x0000_0000
HcRhStatus	0xFFFF0_5050	R/W	Host Controller Root Hub Status Register	0x0000_0000
HcRhPortStatus [1]	0xFFFF0_5054	R/W	Host Controller Root Hub Port Status [1]	0x0000_0000
HcRhPortStatus [2]	0xFFFF0_5058	R/W	Host Controller Root Hub Port Status [2]	0x0000_0000
USB Configuration Registers				
TestModeEnable	0xFFFF0_5200	R/W	USB Test Mode Enable Register	0x0XXX_XXXX
OperationalModeEnable	0xFFFF0_5204	R/W	USB Operational Mode Enable Register	0x0000_0000

W90P710CD/W90P710CDG



USB Device Register Map

REGISTER	ADDRESS	R/W	DESCRIPTION	RESET VALUE
USB_CTL	0xFFFF0_6000	R/W	USB control register	0x0000_0000
VCMD	0xFFFF0_6004	R/W	USB class or vendor command register	0x0000_0000
USB_IE	0xFFFF0_6008	R/W	USB interrupt enable register	0x0000_0000
USB_IS	0xFFFF0_600C	R	USB interrupt status register	0x0000_0000
USB_IC	0xFFFF0_6010	R/W	USB interrupt status clear register	0x0000_0000
USB_IFSTR	0xFFFF0_6014	R/W	USB interface and string register	0x0000_0000
USB_ODATA0	0xFFFF0_6018	R	USB control transfer-out port 0 register	0x0000_0000
USB_ODATA1	0xFFFF0_601C	R	USB control transfer-out port 1 register	0x0000_0000
USB_ODATA2	0xFFFF0_6020	R	USB control transfer-out port 2 register	0x0000_0000
USB_ODATA3	0xFFFF0_6024	R	USB control transfer-out port 3 register	0x0000_0000
USB_IDATA0	0xFFFF0_6028	R/W	USB transfer-in data port0 register	0x0000_0000
USB_IDATA1	0xFFFF0_602C	R/W	USB control transfer-in data port 1	0x0000_0000
USB_IDATA2	0xFFFF0_6030	R/W	USB control transfer-in data port 2	0x0000_0000
USB_IDATA3	0xFFFF0_6034	R/W	USB control transfer-in data port 3	0x0000_0000
USB_SIE	0xFFFF0_6038	R	USB SIE status Register	0x0000_0000
USB_ENG	0xFFFF0_603C	R/W	USB Engine Register	0x0000_0000
USB_CTLS	0xFFFF0_6040	R	USB control transfer status register	0x0000_0000
USB_CONFD	0xFFFF0_6044	R/W	USB Configured Value register	0x0000_0000
EPA_INFO	0xFFFF0_6048	R/W	USB endpoint A information register	0x0000_0000
EPA_CTL	0xFFFF0_604C	R/W	USB endpoint A control register	0x0000_0000
EPA_IE	0xFFFF0_6050	R/W	USB endpoint A Interrupt Enable register	0x0000_0000
EPA_IC	0xFFFF0_6054	W	USB endpoint A interrupt clear register	0x0000_0000
EPA_IS	0xFFFF0_6058	R	USB endpoint A interrupt status register	0x0000_0000
EPA_ADDR	0xFFFF0_605C	R/W	USB endpoint A address register	0x0000_0000
EPA_LENTH	0xFFFF0_6060	R/W	USB endpoint A transfer length register	0x0000_0000
EPB_INFO	0xFFFF0_6064	R/W	USB endpoint B information register	0x0000_0000
EPB_CTL	0xFFFF0_6068	R/W	USB endpoint B control register	0x0000_0000
EPB_IE	0xFFFF0_606C	R/W	USB endpoint B Interrupt Enable register	0x0000_0000
EPB_IC	0xFFFF0_6070	W	USB endpoint B interrupt clear register	0x0000_0000
EPB_IS	0xFFFF0_6074	R	USB endpoint B interrupt status register	0x0000_0000
EPB_ADDR	0xFFFF0_6078	R/W	USB endpoint B address register	0x0000_0000

W90P710CD/W90P710CDG



USB Device Register Map continued

REGISTER	ADDRESS	R/W	DESCRIPTION	RESET VALUE
EPB_LENTH	0xFFFF0_607C	R/W	USB endpoint B transfer length register	0x0000_0000
EPC_INFO	0xFFFF0_6080	R/W	USB endpoint C information register	0x0000_0000
EPC_CTL	0xFFFF0_6084	R/W	USB endpoint C control register	0x0000_0000
EPC_IE	0xFFFF0_6088	R/W	USB endpoint C Interrupt Enable register	0x0000_0000
EPC_IC	0xFFFF0_608C	W	USB endpoint C interrupt clear register	0x0000_0000
EPC_IS	0xFFFF0_6090	R	USB endpoint C interrupt status register	0x0000_0000
EPC_ADDR	0xFFFF0_6094	R/W	USB endpoint C address register	0x0000_0000
EPC_LENTH	0xFFFF0_6098	R/W	USB endpoint C transfer length register	0x0000_0000
EPA_XFER	0xFFFF0_609C	R/W	USB endpoint A remain transfer length register	0x0000_0000
EPA_PKT	0xFFFF0_60A0	R/W	USB endpoint A remain packet length register	0x0000_0000
EPB_XFER	0xFFFF0_60A4	R/W	USB endpoint B remain transfer length register	0x0000_0000
EPB_PKT	0xFFFF0_60A8	R/W	USB endpoint B remain packet length register	0x0000_0000
EPC_XFER	0xFFFF0_60AC	R/W	USB endpoint C remain transfer length register	0x0000_0000
EPC_PKT	0xFFFF0_60B0	R/W	USB endpoint C remain packet length register	0x0000_0000

SD Control Register Map

REGISTER	ADDRESS	R/W	DESCRIPTION	RESET VALUE
SDGCR	0xFFFF0_7000	R/W	SD Global Control Register	0x0000_0000
SDDSA	0xFFFF0_7004	R/W	SD DMA Transfer Starting Address Register	0x0000_0000
SDBCR	0xFFFF0_7008	R/W	SD DMA Byte Count Register	0x0000_0000
SDGIER	0xFFFF0_700C	R/W	SD Global Interrupt Enable Register	0x0000_0000
SDGISR	0xFFFF0_7010	R/W	SD Global Interrupt Status Register	0x0000_0000
SDBIST	0xFFFF0_7014	R/W	SD BIST Register	0x0000_0000
SDCR	0xFFFF0_7300	R/W	SD Control Register	0x0000_0000
SDHINI	0xFFFF0_7304	R/W	SD Host Initial Register	0x0000_0018
SDIER	0xFFFF0_7308	R/W	SD Interrupt Enable Register	0x0000_0000
SDISR	0xFFFF0_730C	R/W	SD Interrupt Status Register	0x0000_00XX
SDAUG	0xFFFF0_7310	R/W	SD Command Argument Register	0x0000_0000
SDRSP0	0xFFFF0_7314	R	SD Receive Response Token Register 0	0xFFFF_XXXX
SDRSP1	0xFFFF0_7318	R	SD Receive Response Token Register 1	0x0000_XXXX
SDBLEN	0xFFFF0_731C	R/W	SD Block Length Register	0x0000_0000

W90P710CD/W90P710CDG



SD Control Register Map continued

REGISTER	ADDRESS	R/W	DESCRIPTION	RESET VALUE
FB0_0 FB0_127	0xFFFF0_7400 0xFFFF0_75FC	R/W	Flash Buffer 0	Undefined
FB1_0 FB1_127	0xFFFF0_7800 0xFFFF0_79FC	R/W	Flash Buffer 1	Undefined

LDCDC Control Register Map

REGISTER	ADDRESS	R/W	DESCRIPTION	RESET VALUE
LCD Controller				
LDCDCON	0xFFFF0_8000	R/W	LCD Control	0x0000_0000
LCD Interrupt Control				
LCDINTENB	0xFFFF0_8004	R/W	LCD Interrupt Enable	0x0000_0000
LCDINTS	0xFFFF0_8008	R	LCD Interrupt Status	0x0000_0000
LCDINTC	0xFFFF0_800C	W	LCD Interrupt Clear	0x0000_0000
LCD Pre-processing				
OSDUPSCF	0xFFFF0_8010	R/W	OSD Horizontal/Vertical upscaling factor	0x0000_0000
VDUPSCF	0xFFFF0_8014	R/W	Video Horizontal/Vertical upscaling factor	0x0000_0000
OSDDNSCF	0xFFFF0_8018	R/W	OSD Horizontal/Vertical downscaling factor	0x0000_0000
VDDNSCF	0xFFFF0_801C	R/W	Video Horizontal/Vertical downscaling factor	0x0000_0000
LCD FIFO Control				
FIFOCON	0xFFFF0_8020	R/W	FIFOs control	0x0000_0000
FIFOSTATUS	0xFFFF0_8024	R	FIFOs status	0x0000_0000
FIFO1PRM	0xFFFF0_8028	R/W	FIFO1 parameters	0x0000_0000
FIFO2PRM	0xFFFF0_802C	R/W	FIFO2 parameters	0x0000_0000
FIFO1SADDR	0xFFFF0_8030	R/W	FIFO1 start address	0x0000_0000
FIFO2SADDR	0xFFFF0_8034	R/W	FIFO2 start address	0x0000_0000
FIFO1DREQCNT	0xFFFF0_8038	R/W	FIFO1 data request count	0x0000_0000
FIFO2DREQCNT	0xFFFF0_803C	R/W	FIFO2 data request count	0x0000_0000
FIFO1CURADR	0xFFFF0_8040	R	FIFO1 current access address	0x0000_0000
FIFO2CURADR	0xFFFF0_8044	R	FIFO2 current access address	0x0000_0000
FIFO1RELACOLCNT	0xFFFF0_8048	R/W	FIFO1 real column count	0x0000_0000
FIFO2RELACOLCNT	0xFFFF0_804C	R/W	FIFO2 real column count	0x0000_0000

W90P710CD/W90P710CDG



LCDC Control Register Map continued.

REGISTER	ADDRESS	R/W	DESCRIPTION	RESET VALUE
Color Generation				
VDLUTENTRY1	0xFFFF0_8050	R/W	Video lookup table entry index 1	0x0000_0000
VDLUTENTRY2	0xFFFF0_8054	R/W	Video lookup table entry index 2	0x0000_0000
VDLUTENTRY3	0xFFFF0_8058	R/W	Video lookup table entry index 3	0x0000_0000
VDLUTENTRY4	0xFFFF0_805C	R/W	Video lookup table entry index 4	0x0000_0000
OSDLUTENTRY1	0xFFFF0_8060	R/W	OSD lookup table entry index 1	0x0000_0000
OSDLUTENTRY2	0xFFFF0_8064	R/W	OSD lookup table entry index 2	0x0000_0000
OSDLUTENTRY3	0xFFFF0_8068	R/W	OSD lookup table entry index 3	0x0000_0000
OSDLUTENTRY4	0xFFFF0_806C	R/W	OSD lookup table entry index 4	0x0000_0000
DITHP1	0xFFFF0_8070	R/W	Gray level dithered data duty pattern 1	0x0101_0001
DITHP2	0xFFFF0_8074	R/W	Gray level dithered data duty pattern 2	0x1111_0841
DITHP3	0xFFFF0_8078	R/W	Gray level dithered data duty pattern 3	0x4949_2491
DITHP4	0xFFFF0_807C	R/W	Gray level dithered data duty pattern 4	0x5555_52A5
DITHP5	0xFFFF0_8080	R/W	Gray level dithered data duty pattern 5	0xB6B6_B556
DITHP6	0xFFFF0_8084	R/W	Gray level dithered data duty pattern 6	0xEEEE_DB6E
DITHP7	0xFFFF0_8088	R/W	Gray level dithered data duty pattern 7	0xEFEF_EFBE
LCD Post-processing				
DDISPCP	0xFFFF0_8090	R/W	Dummy Display Color Pattern	0x0000_0000
VWINS	0xFFFF0_8094	R/W	Video Window Starting Coordinate	0x0000_0000
VWINE	0xFFFF0_8098	R/W	Video Window Ending Coordinate	0x0000_0000
OSDWINS	0xFFFF0_809C	R/W	OSD Window Starting Coordinate	0x0000_0000
OSDWINE	0xFFFF0_80A0	R/W	OSD Window Ending Coordinate	0x0000_0000
OSDOVCN	0xFFFF0_80A4	R/W	OSD Overlay Control	0x0000_0000
OSDCKP	0xFFFF0_80A8	R/W	OSD Overlay Color-Key Pattern	0x0000_0000
OSDCKM	0xFFFF0_80AC	R/W	OSD Overlay Color-Key Mask	0x0000_0000
LCD Timing Generation				
LCDTCON1	0xFFFF0_80B0	R/W	LCD Timing Control 1	0x0000_0000
LCDTCON2	0xFFFF0_80B4	R/W	LCD Timing Control 2	0x0000_0000
LCDTCON3	0xFFFF0_80B8	R/W	LCD Timing Control 3	0x0000_0000
LCDTCON4	0xFFFF0_80BC	R/W	LCD Timing Control 4	0x0000_0000
LCDTCON5	0xFFFF0_80C0	R/W	LCD Timing Control 5	0x0000_0000
LCDTCON6	0xFFFF0_80C4	R	LCD Timing Control 6	0x0000_0000
Lookup Table SRAM Build In Self Test				
BIST	0xFFFF0_80D0	R/W		0x0000_0000

W90P710CD/W90P710CDG



LCDC Control Register Map, continued.

REGISTER	ADDRESS	R/W	DESCRIPTION	RESET VALUE
Lookup Table SRAM				
	0xFFFF0_0100 ... 0xFFFF0_84FF	R/W	Look-Up Table RAM	0XXXXX_XXXX

Audio Control Register Map

REGISTER	ADDRESS	R/W	DESCRIPTION	RESET VALUE
ACTL_CON	0xFFFF0_9000	R/W	Audio controller control register	0x0000_0000
ACTL_RESET	0xFFFF0_9004	R/W	Sub block reset control register	0x0000_0000
ACTL_RDSTB	0xFFFF0_9008	R/W	DMA destination base address register for record	0x0000_0000
ACTL_RDST_LENGTH	0xFFFF0_900C	R/W	DMA destination length register for record	0x0000_0000
ACTL_RDSTC	0xFFFF0_9010	R	DMA destination current address register for record	0x0000_0000
ACTL_RSR	0xFFFF0_9014	R/W	Record status register	0x0000_0000
ACTL_PDSTB	0xFFFF0_9018	R/W	DMA destination base address register for play	0x0000_0000
ACTL_PDST_LENGTH	0xFFFF0_901C	R/W	DMA destination length register for play	0x0000_0000
ACTL_PDSTC	0xFFFF0_9020	R	DMA destination current address register for play	0x0000_0000
ACTL_PSR	0xFFFF0_9024	R/W	Play status register	0x0000_0004
ACTL_IISCON	0xFFFF0_9028	R/W	IIS control register	0x0000_0000
ACTL_ACCON	0xFFFF0_902C	R/W	AC-link control register	0x0000_0000
ACTL_ACOS0	0xFFFF0_9030	R/W	AC-link out slot 0	0x0000_0000
ACTL_ACOS1	0xFFFF0_9034	R/W	AC-link out slot 1	0x0000_0080
ACTL_ACOS2	0xFFFF0_9038	R/W	AC-link out slot 2	0x0000_0000
ACTL_ACIS0	0xFFFF0_903C	R	AC-link in slot 0	0x0000_0000
ACTL_ACIS1	0xFFFF0_9040	R	AC-link in slot 1	0x0000_0000
ACTL_ACIS2	0xFFFF0_9044	R	AC-link in slot 2	0x0000_0000

Cache Controller Test Registers Map

REGISTER	ADDRESS	R/W	DESCRIPTION	RESET VALUE
CTEST0	0xFFFF6_0000	R/W	Cache test register 0	0x0000_0000
CTEST1	0xFFFF6_0004	R	Cache test register 1	0x0000_0000

W90P710CD/W90P710CDG



UART0 Control Registers Map

REGISTER	ADDRESS	R/W	DESCRIPTION	RESET VALUE
UART0_RBR	0xFFFF8_0000	R	Receive Buffer Register (DLAB = 0)	Undefined
UART0_THR	0xFFFF8_0000	W	Transmit Holding Register (DLAB = 0)	Undefined
UART0_IER	0xFFFF8_0004	R/W	Interrupt Enable Register (DLAB = 0)	0x0000_0000
UART0_DLL	0xFFFF8_0000	R/W	Divisor Latch Register (LS) (DLAB = 1)	0x0000_0000
UART0_DLM	0xFFFF8_0004	R/W	Divisor Latch Register (MS) (DLAB = 1)	0x0000_0000
UART0_IIR	0xFFFF8_0008	R	Interrupt Identification Register	0x8181_8181
UART0_FCR	0xFFFF8_0008	W	FIFO Control Register	Undefined
UART0_LCR	0xFFFF8_000C	R/W	Line Control Register	0x0000_0000
UART0_LSR	0xFFFF8_0014	R	Line Status Register	0x6060_6060
UART0_TOR	0xFFFF8_001C	R	Timeout Register	0x0000_0000

High Speed UART1 Control Registers Map

REGISTER	ADDRESS	R/W	DESCRIPTION	RESET VALUE
UART1_RBR	0xFFFF8_0100	R	Receive Buffer Register (DLAB = 0)	Undefined
UART1_THR	0xFFFF8_0100	W	Transmit Holding Register (DLAB = 0)	Undefined
UART1_IER	0xFFFF8_0104	R/W	Interrupt Enable Register (DLAB = 0)	0x0000_0000
UART1_DLL	0xFFFF8_0100	R/W	Divisor Latch Register (LS) (DLAB = 1)	0x0000_0000
UART1_DLM	0xFFFF8_0104	R/W	Divisor Latch Register (MS) (DLAB = 1)	0x0000_0000
UART1_IIR	0xFFFF8_0108	R	Interrupt Identification Register	0x8181_8181
UART1_FCR	0xFFFF8_0108	W	FIFO Control Register	Undefined
UART1_LCR	0xFFFF8_010C	R/W	Line Control Register	0x0000_0000
UART1_MCR	0xFFFF8_0110	R/W	Modem Control Register	0x0000_0000
UART1_LSR	0xFFFF8_0114	R	Line Status Register	0x6060.6060
UART1_MSR	0xFFFF8_0118	R	MODEM Status Register	0x0000_0000
UART1_TOR	0xFFFF8_011C	R	Timeout Register	0x0000_0000
UART1_UBCR	0xFFFF8_0120	R/W	UART1 Bluetooth Control Register	0x0000_0000



UART2 Control Register Map

REGISTER	ADDRESS	R/W	DESCRIPTION	RESET VALUE
UART2_RBR	0xFFFF8_0200	R	Receive Buffer Register (DLAB = 0)	Undefined
UART2_THR	0xFFFF8_0200	W	Transmit Holding Register (DLAB = 0)	Undefined
UART2_IER	0xFFFF8_0204	R/W	Interrupt Enable Register (DLAB = 0)	0x0000_0000
UART2_DLL	0xFFFF8_0200	R/W	Divisor Latch Register (LS) (DLAB = 1)	0x0000_0000
UART2_DLM	0xFFFF8_0204	R/W	Divisor Latch Register (MS) (DLAB = 1)	0x0000_0000
UART2_IIR	0xFFFF8_0208	R	Interrupt Identification Register	0x8181_8181
UART2_FCR	0xFFFF8_0208	W	FIFO Control Register	Undefined
UART2_LCR	0xFFFF8_020C	R/W	Line Control Register	0x0000_0000
UART2_MCR	0xFFFF8_0210	R/W	Modem Control Register	0x0000_0000
UART2_LSR	0xFFFF8_0214	R	Line Status Register	0x6060_6060
UART2_MSR	0xFFFF8_0218	R	MODEM Status Register	0x0000_0000
UART2_TOR	0xFFFF8_021C	R	Timeout Register	0x0000_0000
UART2_IRCR	0xFFFF8_0220	R/W	IrDA Control Register	0x0000_0040

UART3 Control Register Map

REGISTER	ADDRESS	R/W	DESCRIPTION	RESET VALUE
UART3_RBR	0xFFFF8_0300	R	Receive Buffer Register (DLAB = 0)	Undefined
UART3_THR	0xFFFF8_0300	W	Transmit Holding Register (DLAB = 0)	Undefined
UART3_IER	0xFFFF8_0304	R/W	Interrupt Enable Register (DLAB = 0)	0x0000_0000
UART3_DLL	0xFFFF8_0300	R/W	Divisor Latch Register (LS) (DLAB = 1)	0x0000_0000
UART3_DLM	0xFFFF8_0304	R/W	Divisor Latch Register (MS) (DLAB = 1)	0x0000_0000
UART3_IIR	0xFFFF8_0308	R	Interrupt Identification Register	0x8181_8181
UART3_FCR	0xFFFF8_0308	W	FIFO Control Register	Undefined
UART3_LCR	0xFFFF8_030C	R/W	Line Control Register	0x0000_0000
UART3_MCR	0xFFFF8_0310	R/W	Modem Control Register	0x0000_0000
UART3_LSR	0xFFFF8_0314	R	Line Status Register	0x6060_6060
UART3_MSR	0xFFFF8_0318	R	MODEM Status Register	0x0000_0000
UART3_TOR	0xFFFF8_031C	R	Timeout Register	0x0000_0000

**Timer Control Registers Map**

REGISTER	ADDRESS	R/W	DESCRIPTION	RESET VALUE
TCR0	0xFFFF8_1000	R/W	Timer Control Register 0	0x0000_0005
TCR1	0xFFFF8_1004	R/W	Timer Control Register 1	0x0000_0005
TICR0	0xFFFF8_1008	R/W	Timer Initial Control Register 0	0x0000_00FF
TICR1	0xFFFF8_100C	R/W	Timer Initial Control Register 1	0x0000_00FF
TDR0	0xFFFF8_1010	R	Timer Data Register 0	0x0000_0000
TDR1	0xFFFF8_1014	R	Timer Data Register 1	0x0000_0000
TISR	0xFFFF8_1018	R/C	Timer Interrupt Status Register	0x0000_0000
WTCR	0xFFFF8_101C	R/W	Watchdog Timer Control Register	0x0000_0000

AIC Control Registers Map

REGISTER	ADDRESS	R/W	DESCRIPTION	RESET VALUE
AIC_SCR1	0xFFFF8_2004	R/W	Source Control Register 1	0x0000_0047
AIC_SCR2	0xFFFF8_2008	R/W	Source Control Register 2	0x0000_0047
AIC_SCR3	0xFFFF8_200C	R/W	Source Control Register 3	0x0000_0047
AIC_SCR4	0xFFFF8_2010	R/W	Source Control Register 4	0x0000_0047
AIC_SCR5	0xFFFF8_2014	R/W	Source Control Register 5	0x0000_0047
AIC_SCR6	0xFFFF8_2018	R/W	Source Control Register 6	0x0000_0047
AIC_SCR7	0xFFFF8_201C	R/W	Source Control Register 7	0x0000_0047
AIC_SCR8	0xFFFF8_2020	R/W	Source Control Register 8	0x0000_0047
AIC_SCR9	0xFFFF8_2024	R/W	Source Control Register 9	0x0000_0047
AIC_SCR10	0xFFFF8_2028	R/W	Source Control Register 10	0x0000_0047
AIC_SCR11	0xFFFF8_202C	R/W	Source Control Register 11	0x0000_0047
AIC_SCR12	0xFFFF8_2030	R/W	Source Control Register 12	0x0000_0047
AIC_SCR13	0xFFFF8_2034	R/W	Source Control Register 13	0x0000_0047
AIC_SCR14	0xFFFF8_2038	R/W	Source Control Register 14	0x0000_0047
AIC_SCR15	0xFFFF8_203C	R/W	Source Control Register 15	0x0000_0047
AIC_SCR16	0xFFFF8_2040	R/W	Source Control Register 16	0x0000_0000
AIC_SCR17	0xFFFF8_2044	R/W	Source Control Register 17	0x0000_0000
AIC_SCR18	0xFFFF8_2048	R/W	Source Control Register 18	0x0000_0000
AIC_SCR19	0xFFFF8_204C	R/W	Source Control Register 19	0x0000_0047
AIC_SCR20	0xFFFF8_2050	R/W	Source Control Register 20	0x0000_0047

W90P710CD/W90P710CDG



AIC Control Registers Map continued

REGISTER	ADDRESS	R/W	DESCRIPTION	RESET VALUE
AIC_SCR21	0xFFFF8_2054	R/W	Source Control Register 21	0x0000_0047
AIC_SCR22	0xFFFF8_2058	R/W	Source Control Register 22	0x0000_0047
AIC_SCR23	0xFFFF8_205C	R/W	Source Control Register 23	0x0000_0047
AIC_SCR24	0xFFFF8_2060	R/W	Source Control Register 24	0x0000_0047
AIC_SCR25	0xFFFF8_2064	R/W	Source Control Register 25	0x0000_0047
AIC_SCR26	0xFFFF8_2068	R/W	Source Control Register 26	0x0000_0047
AIC_SCR27	0xFFFF8_206C	R/W	Source Control Register 27	0x0000_0047
AIC_SCR28	0xFFFF8_2070	R/W	Source Control Register 28	0x0000_0047
AIC_SCR29	0xFFFF8_2074	R/W	Source Control Register 29	0x0000_0047
AIC_SCR30	0xFFFF8_2078	R/W	Source Control Register 30	0x0000_0047
AIC_SCR31	0xFFFF8_207C	R/W	Source Control Register 31	0x0000_0047
AIC_IRSR	0xFFFF8_2100	R	Interrupt Raw Status Register	0x0000_0000
AIC_IASR	0xFFFF8_2104	R	Interrupt Active Status Register	0x0000_0000
AIC_ISR	0xFFFF8_2108	R	Interrupt Status Register	0x0000_0000
AIC_IPER	0xFFFF8_210C	R	Interrupt Priority Encoding Register	0x0000_0000
AIC_ISNR	0xFFFF8_2110	R	Interrupt Source Number Register	0x0000_0000
AIC_IMR	0xFFFF8_2114	R	Interrupt Mask Register	0x0000_0000
AIC_OISR	0xFFFF8_2118	R	Output Interrupt Status Register	0x0000_0000
AIC_MECR	0xFFFF8_2120	W	Mask Enable Command Register	Undefined
AIC_MDCR	0xFFFF8_2124	W	Mask Disable Command Register	Undefined
AIC_SSCR	0xFFFF8_2128	W	Source Set Command Register	Undefined
AIC_SCCR	0xFFFF8_212C	W	Source Clear Command Register	Undefined
AIC_EOSCR	0xFFFF8_2130	W	End of Service Command Register	Undefined
AIC_TEST	0xFFFF8_2200	W	ICE/Debug mode Register	Undefined

W90P710CD/W90P710CDG



GPIO Control Register Map

REGISTER	ADDRESS	R/W	DESCRIPTION	RESET VALUE
GPIO_CFG0	0xFFF8_3000	R/W	GPIO port0 configuration register	0x0000_0000
GPIO_DIR0	0xFFF8_3004	R/W	GPIO port0 direction control register	0x0000_0000
GPIO_DATAOUT0	0xFFF8_3008	R/W	GPIO port0 data output register	0x0000_0000
GPIO_DATAIN0	0xFFF8_300C	R	GPIO port0 data input register	0xFFFF_XXXX
GPIO_CFG1	0xFFF8_3010	R/W	GPIO port1 configuration register	0x0000_0000
GPIO_DIR1	0xFFF8_3014	R/W	GPIO port1 direction control register	0x0000_0000
GPIO_DATAOUT1	0xFFF8_3018	R/W	GPIO port1 data output register	0x0000_0000
GPIO_DATAIN1	0xFFF8_301C	R	GPIO port1 data input register	0xFFFF_XXXX
GPIO_CFG2	0xFFF8_3020	R/W	GPIO port2 configuration register	0x0000_0000
GPIO_DIR2	0xFFF8_3024	R/W	GPIO port2 direction control register	0x0000_0000
GPIO_DATAOUT2	0xFFF8_3028	R/W	GPIO port2 data output register	0x0000_0000
GPIO_DATAIN2	0xFFF8_302C	R	GPIO port2 data input register	0x0000_0000
GPIO_CFG3	0xFFF8_3030	R/W	GPIO port3 configuration register	0x0000_5555
GPIO_DIR3	0xFFF8_3034	R/W	GPIO port3 direction control register	0x0000_0000
GPIO_DATAOUT3	0xFFF8_3038	R/W	GPIO port3 data output register	0x0000_0000
GPIO_DATAIN3	0xFFF8_303C	R	GPIO port3 data input register	0xFFFF_XXXX
GPIO_CFG4	0xFFF8_3040	R/W	GPIO port4 configuration register	0x0015_5555
GPIO_DIR4	0xFFF8_3044	R/W	GPIO port4 direction control register	0x0000_0000
GPIO_DATAOUT4	0xFFF8_3048	R/W	GPIO port4 data output register	0x0000_0000
GPIO_DATAIN4	0xFFF8_304C	R	GPIO port4 data input register	0xFFFF_XXXX
GPIO_CFG5	0xFFF8_3050	R/W	GPIO port5 configuration register	0x0000_0000
GPIO_DIR5	0xFFF8_3054	R/W	GPIO port5 direction control register	0x0000_0000
GPIO_DATAOUT5	0xFFF8_3058	R/W	GPIO port5 data output register	0x0000_0000
GPIO_DATAIN5	0xFFF8_305C	R	GPIO port5 data input register	0xFFFF_XXXX
GPIO_CFG6	0xFFF8_3060	R/W	GPIO port6 configuration register	0x0000_0000
GPIO_DIR6	0xFFF8_3064	R/W	GPIO port6 direction control register	0x0000_0000
GPIO_DATAOUT6	0xFFF8_3068	R/W	GPIO port6 data output register	0x0000_0000
GPIO_DATAIN6	0xFFF8_306C	R	GPIO port6 data input register	0xFFFF_XXXX
GPIO_DBNCECON	0xFFF8_3070	R/W	GPIO input debounce control register	0x0000_0000
GPIO_XICFG	0xFFF8_3074	R/W	Extended Interrupt Configure Register	0xFFFF_XXX0
GPIO_XISTATUS	0xFFF8_3078	R/W	Extended Interrupt Status Register	0xFFFF_XXX0

W90P710CD/W90P710CDG



RTC Control Register Map

REGISTER	ADDRESS	R/W	DESCRIPTION	RESET VALUE
RTC_INIR	0xFFF8_4000	R/W	RTC Initiation Register	-
RTC_AER	0xFFF8_4004	R/W	RTC Access Enable Register	0x0000_0000
RTC_FCR	0xFFF8_4008	R/W	RTC Frequency Compensation Register	0x0000_0700
RTC_TLR	0xFFF8_400C	R/W	Time Loading Register	0x0000_0000
RTC_CLR	0xFFF8_4010	R/W	Calendar Loading Register	0x0005_0101
RTC_TSSR	0xFFF8_4014	R/W	Time Scale Selection Register	0x0000_0001
RTC_DWR	0xFFF8_4018	R/W	Day of the Week Register	0x0000_0006
RTC_TAR	0xFFF8_401C	R/W	Time Alarm Register	0x0000_0000
RTC_CAR	0xFFF8_4020	R/W	Calendar Alarm Register	0x0000_0000
RTC_LIR	0xFFF8_4024	R	Leap year Indicator Register	0x0000_0000
RTC_RIER	0xFFF8_4028	R/W	RTC Interrupt Enable Register	0x0000_0000
RTC_RIIR	0xFFF8_402C	R/C	RTC Interrupt Indicator Register	0x0000_0000
RTC_TTR	0xFFF8_4030	R/W	RTC Tick Time Register	0x0000_0000

Smart card Host Control Register Map

REGISTER	ADDRESS	R/W	DESCRIPTION	RESET VALUE
Smartcard Host Interface 0				
SCHI_RBR0	0xFFF8_5000 (BDLAB=0)	R	Receiver Buffer Register	Undefined
SCHI_TBR0	0xFFF8_5000 (BDLAB=0)	W	Transmitter Buffer Register	Undefined
SCHI_IER0	0xFFF8_5004 (BDLAB=0)	R/W	Interrupt Enable Register	0x0000_0080
SCHI_ISR0	0xFFF8_5008 (BDLAB=0)	R	Interrupt Status Register	0x0000_00C1
SCHI_SCFR0	0xFFF8_5008 (BDLAB=0)	W	Smart card FIFO Control Register	0x0000_0000
SCHI_SCCR0	0xFFF8_500C	R/W	Smart card Control Register	0x0000_0010
SCHI_CBR0	0xFFF8_5010	R/W	Clock Base Register	0x0000_000C
SCHI_SCSR0	0xFFF8_5014	R	Smart Card Status Register	0x0000_0060
SCHI_GTR0	0xFFF8_5018	R/W	Guard Time Register	0x0000_0001
SCHI_ECR0	0xFFF8_501C	R/W	Extended Control Register	0x0000_0052
SCHI_TMR0	0xFFF8_5020	R/W	Test Mode Register	0x0000_0000
SCHI_TOC0	0xFFF8_5028	R/W	Timeout Configuration Register	0x0000_0000

W90P710CD/W90P710CDG



Smart card Host Control Register Map continued.

REGISTER	ADDRESS	R/W	DESCRIPTION	RESET VALUE
Smartcard Host Interface 0				
SCHI_TOIR0_0	0xFFF8_502C	R/W	Timeout Initial Register 0	0x0000_0000
SCHI_TOIR1_0	0xFFF8_5030	R/W	Timeout Initial Register 1	0x0000_0000
SCHI_TOIR2_0	0xFFF8_5034	R/W	Timeout Initial Register 2	0x0000_0000
SCHI_TOD0_0	0xFFF8_5038	R	Timeout Data Register 0	0x0000_00FF
SCHI_TOD1_0	0xFFF8_503C	R	Timeout Data Register 1	0x0000_00FF
SCHI_TOD2_0	0xFFF8_5040	R	Timeout Data Register 2	0x0000_00FF
SCHI_BTOR_0	0xFFF8_5044	R/W	Buffer Timeout Data Register	0x0000_0000
SCHI_BLL_0	0xFFF8_5000 (BDLAB=1)	R/W	Baud Rate Divisor Latch Lower Byte Register	0x0000_001F
SCHI_BLH_0	0xFFF8_5004 (BDLAB=1)	R/W	Baud Rate Divisor Latch Higher Byte Register	0x0000_0000
SCHI_ID_0	0xFFF8_5008 (BDLAB=1)	R	Smart Card ID Number Register	0x0000_0070
Smartcard Host Interface 1				
SCHI_RBR1	0xFFF8_5800 (BDLAB=0)	R	Receiver Buffer Register	Undefined
SCHI_TBR1	0xFFF8_5800 (BDLAB=0)	W	Transmitter Buffer Register	Undefined
SCHI_IER1	0xFFF8_5804 (BDLAB=0)	R/W	Interrupt Enable Register	0x0000_0080
SCHI_ISR1	0xFFF8_5808 (BDLAB=0)	R	Interrupt Status Register	0x0000_00C1
SCHI_SCFR1	0xFFF8_5808 (BDLAB=0)	W	Smart card FIFO Control Register	0x0000_0000
SCHI_SCCR1	0xFFF8_580C	R/W	Smart card Control Register	0x0000_0010
SCHI_CBR1	0xFFF8_5810	R/W	Clock Base Register	0x0000_000C
SCHI_SCSR1	0xFFF8_5814	R	Smart Card Status Register	0x0000_0060
SCHI_GTR1	0xFFF8_5818	R/W	Guard Time Register	0x0000_0001
SCHI_ECR1	0xFFF8_581C	R/W	Extended Control Register	0x0000_0052
SCHI_TMR1	0xFFF8_5820	R/W	Test Mode Register	0x0000_0000
SCHI_TOC1	0xFFF8_5828	R/W	Timeout Configuration Register	0x0000_0000
SCHI_TOIR0_1	0xFFF8_582C	R/W	Timeout Initial Register 0	0x0000_0000
SCHI_TOIR1_1	0xFFF8_5830	R/W	Timeout Initial Register 1	0x0000_0000
SCHI_TOIR2_1	0xFFF8_5834	R/W	Timeout Initial Register 2	0x0000_0000

W90P710CD/W90P710CDG



Smart card Host Control Register Map continued.

REGISTER	ADDRESS	R/W	DESCRIPTION	RESET VALUE
Smartcard Host Interface 0				
SCHI_TOD0_1	0xFFF8_5838	R	Timeout Data Register 0	0x0000_00FF
SCHI_TOD1_1	0xFFF8_583C	R	Timeout Data Register 1	0x0000_00FF
SCHI_TOD2_1	0xFFF8_5840	R	Timeout Data Register 2	0x0000_00FF
SCHI_BTOR1	0xFFF8_5844	R/W	Buffer Timeout Data Register	0x0000_0000
SCHI_BLL1	0xFFF8_5800 (BDLAB=1)	R/W	Baud Rate Divisor Latch Lower Byte Register	0x0000_001F
SCHI_BLH1	0xFFF8_5804 (BDLAB=1)	R/W	Baud Rate Divisor Latch Higher Byte Register	0x0000_0000
SCHI_ID1	0xFFF8_5808 (BDLAB=1)	R	Smart Card ID Number Register	0x0000_0070

I2C Register Map

REGISTER	ADDRESS	R/W	DESCRIPTION	RESET VALUE
I2C Interface 0				
I2C_CSR0	0xFFF8_6000	R/W	I2C0 Control and Status Register	0x0000_0000
I2C_DIVIDER0	0xFFF8_6004	R/W	I2C0 Clock Prescale Register	0x0000_0000
I2C_CMDR0	0xFFF8_6008	R/W	I2C0 Command Register	0x0000_0000
I2C_SWR0	0xFFF8_600C	R/W	I2C0 Software Mode Control Register	0x0000_003F
I2C_RxR0	0xFFF8_6010	R	I2C0 Data Receive Register	0x0000_0000
I2C_TxR0	0xFFF8_6014	R/W	I2C0 Data Transmit Register	0x0000_0000
I2C Interface 1				
I2C_CSR1	0xFFF8_6000	R/W	I2C1 Control and Status Register	0x0000_0000
I2C_DIVIDER1	0xFFF8_6004	R/W	I2C1 Clock Prescale Register	0x0000_0000
I2C_CMDR1	0xFFF8_6008	R/W	I2C1 Command Register	0x0000_0000
I2C_SWR1	0xFFF8_600C	R/W	I2C1 Software Mode Control Register	0x0000_003F
I2C_RxR1	0xFFF8_6010	R	I2C1 Data Receive Register	0x0000_0000
I2C_TxR1	0xFFF8_6014	R/W	I2C1 Data Transmit Register	0x0000_0000

W90P710CD/W90P710CDG



USI Register Map

REGISTER	ADDRESS	R/W	DESCRIPTION	RESET VALUE
USI_CNTRL	0xFFF8_6200	R/W	Control and Status Register	0x0000_0004
USI_DIVIDER	0xFFF8_6204	R/W	Clock Divider Register	0x0000_0000
USI_SSR	0xFFF8_6208	R/W	Slave Select Register	0x0000_0000
Reserved	0xFFF8_620C	N/A	Reserved	N/A
USI_Rx0	0xFFF8_6210	R	Data Receive Register 0	0x0000_0000
USI_Rx1	0xFFF8_6214	R	Data Receive Register 1	0x0000_0000
USI_Rx2	0xFFF8_6218	R	Data Receive Register 2	0x0000_0000
USI_Rx3	0xFFF8_621C	R	Data Receive Register 3	0x0000_0000
USI_Tx0	0xFFF8_6210	W	Data Transmit Register 0	0x0000_0000
USI_Tx1	0xFFF8_6214	W	Data Transmit Register 1	0x0000_0000
USI_Tx2	0xFFF8_6218	W	Data Transmit Register 2	0x0000_0000
USI_Tx3	0xFFF8_621C	W	Data Transmit Register 3	0x0000_0000

PWM Control Register Map

REGISTER	ADDRESS	R/W	DESCRIPTION	RESET VALUE
PWM_PPR	0xFFF8_7000	R/W	PWM Prescaler Register	0x0000_0000
PWM_CSR	0xFFF8_7004	R/W	PWM Clock Select Register	0x0000_0000
PWM_PCR	0xFFF8_7008	R/W	PWM Control Register	0x0000_0000
PWM_CNR0	0xFFF8_700C	R/W	PWM Counter Register 0	0x0000_0000
PWM_CMRO	0xFFF8_7010	R/W	PWM Comparator Register 0	0x0000_0000
PWM_PDR0	0xFFF8_7014	R	PWM Data Register 0	0x0000_0000
PWM_CNR1	0xFFF8_7018	R/W	PWM Counter Register 1	0x0000_0000
PWM_CMRO1	0xFFF8_701C	R/W	PWM Comparator Register 1	0x0000_0000
PWM_PDR1	0xFFF8_7020	R	PWM Data Register 1	0x0000_0000
PWM_CNR2	0xFFF8_7024	R/W	PWM Counter Register 2	0x0000_0000
PWM_CMRO2	0xFFF8_7028	R/W	PWM Comparator 2	0x0000_0000
PWM_PDR2	0xFFF8_702C	R	PWM Data Register 2	0x0000_0000
PWM_CNR3	0xFFF8_7030	R/W	PWM Counter Register 3	0x0000_0000
PWM_CMRO3	0xFFF8_7034	R/W	PWM Comparator Register 3	0x0000_0000
PWM_PDR3	0xFFF8_7038	R	PWM Data Register 3	0x0000_0000
PWM_PIER	0xFFF8_703C	R/W	PWM Interrupt Enable Register	0x0000_0000
PWM_PIIR	0xFFF8_7040	R/C	PWM Interrupt Indication Register	0x0000_0000

**KPI Control Register Map**

REGISTER	ADDRESS	R/W	DESCRIPTION	RESET VALUE
KPICONF	0xFFF8_8000	R/W	Keypad controller configuration Register	0x0000_0000
KPI3KCONF	0xFFF8_8004	R/W	Keypad controller 3-keys configuration register	0x0000_0000
KPILPCONF	0xFFF8_8008	R/W	Keypad controller low power configuration register	0x0000_0000
KPISTATUS	0xFFF8_800C	R/O	Keypad controller status register	0x0000_0000

PS2 Control Register Map

REGISTER	ADDRESS	R/W	DESCRIPTION	RESET VALUE
PS2CMD	0xFFF8_9000	R/W	PS2 Host Controller Command Register	0x0000_0000
PS2STS	0xFFF8_9004	R/W	PS2 Host Controller Status Register	0x0000_0000
PS2SCANCODE	0xFFF8_9008	RO	PS2 Host Controller RX Scan Code Register	0x0000_0000
PS2ASCII	0xFFF8_900C	RO	PS2 Host Controller RX ASCII Code Register	0x0000_0000



11. REVISION HISTORY

REVISION	DATE	COMMENTS
A1(A)	2005/12/02	Draft
A2(A.1)	2005/12/21	Modified the register definition
A3(A.2)	2006/01/17	Modified SD description
A4(A.3)	2006/07/07	Updated LCD C version design spec. Updated Smartcard C version design spec. Added RTC 32.768K clock measurement application note. Added RTC application note.
A5(B)	2006/07/26	Changed EBI SDRAM control register SDCONFx[13] AUTOPR definition. Modified LCD register map section 7.2.2 Changed 2 to 1 slave/device select lines Changed SDIO to SD Added Electrical specification
A6(B1)	2006/08/08	SDO changed to SD page 11 SDIO changed to SD page 33 "W99P710" changed to "W90P710" page 245 Deleted "it is same as the UART of W99740" page 333 Deleted "it is same as the UART of W99702" page 332 Deleted "note" page 337,338 Added USB WakeUp control bit Updated table 5.2
A7(B2)	2006/09/19	Deleted section 6
A8(B3)	2007/01/23	Add" Ambient temperature" Changed USB Host Controller, Page184 Changed USB Host Controller, Page 180 Changed SD Host Controller. Page 228 Changed LCD Controller, Page 278 Changed GPIO, Page 412 Changed Real Time Clock RTC. Page 418~434 Changed Smart Card Host Controller, Page 460
A9(B4)	2007/07/20	1. Correct table 5.1 (nWBE2/GPIO 68, nWBE3/GPIO69) 2. Correct Table 6.15.1 (ADD VD[8:17] to PORT 2)

W90P710CD/W90P710CDG



Important Notice

Winbond products are not designed, intended, authorized or warranted for use as components in systems or equipment intended for surgical implantation, atomic energy control instruments, airplane or spaceship instruments, transportation instruments, traffic signal instruments, combustion control instruments, or for other applications intended to support or sustain life. Furthermore, Winbond products are not intended for applications wherein failure of Winbond products could result or lead to a situation wherein personal injury, death or severe property or environmental damage could occur.

Winbond customers using or selling these products for use in such applications do so at their own risk and agree to fully indemnify Winbond for any damages resulting from such improper use or sales.

*Please note that all data and specifications are subject to change without notice.
All the trademarks of products and companies mentioned in this datasheet belong to their respective owners.*