

## 24-Port Integrated Layer-2 Gigabit Ethernet Smart Switch with Transceivers

VSC7390 SparX-G24™ is the highly integrated, single-chip Gigabit Ethernet switch with eight Integrated GbE Copper PHY ports. As part of the Vitesse SparX™ Family of Switches, SparX-G24 delivers high performance with easy migration paths, and comprehensive system solutions that enable ultra-short time-to-market and market-leading system cost.

### A Vitesse Switch Family Member

SparX-G24 is a part of the Vitesse SparX™ Family of Unmanaged or Web-Managed Switches and takes the family into a new generation of integration. With its eight tri-speed Gigabit Ethernet copper ports and 16 SGMII ports, it is specifically targeted at SMB, SME and SOHO unmanaged applications, and with its on-chip V-Core CPU and parallel CPU interface it enables web-managed and managed switch applications.

Being a member of the SparX™ switch family provides a number of unique advantages when designing with the device, including software compatibility between members. Software written for SparX-G24 can therefore easily be ported from or used with other switch configurations in the family, and vice-versa.

Additionally, building a product family is easy when designing with Vitesse switches. Upgrading designs to higher port counts, or migrating to other configurations or future technology is achievable with a minimum of effort and time.

### The Vitesse SparX Family of Switches

SparX-G24, as part of the Vitesse SparX Family of Switches, shares the unique traits of the family.

The highly integrated switches require no external memory, and the integration of copper PHY as well as internal oscillator circuits simplifies the design effort. The requirement of needing only two power supply rails reduces the additional DC/DC converter cost. Further trimming down system cost is the persistently low power dissipation of the family. In addition, the value-added features in SparX-G24 enables the customer to provide advanced features without the need of enterprise class silicon.

The switches provide non-blocking, wire-speed performance designs with wire-speed MAC address learning or CPU-based address learning.

Designing both unmanaged and managed solutions is straightforward. The devices offer both an internal V-Core CPU and serial and parallel CPU interfaces, and support a host of management protocols such as GxRP, SNMP, and three flavors of Spanning Tree: Standard STP, Multiple STP, and Rapid STP.

Controlling networks operated by the Vitesse switches is simple; advanced classification with IPv4 and IPv6 support, along with port DSCP remarking and 802.1x authentication support, provide flexible QoS operation. This is backed up by Layer 2-4 link aggregation and VLAN support, enabling managed switches to be deployed.

## APPLICATIONS

- 24-port unmanaged Gigabit Ethernet SMB/SME/SOHO switch
- 24-port web-managed smart Gigabit Ethernet SMB/SME/SOHO switch

## SPECIFICATIONS

- 25-MHz, 125-MHz LVTTTL reference clock
- 3.3 V interface power supply
- 1.2 V core power supply
- Thermally enhanced PBGA package

With its unique low power dissipation, SparX-G24 reduces thermal management cost for system design and thereby provides for higher system reliability to the benefit of the user.

Designing with Vitesse SparX Family of Switches means designing with the whole Vitesse Solution:

The outstanding Vitesse web-managed switch software system that runs on the on-chip V-Core CPU is provided. This is in addition to the unmanaged and smart managed software systems for an external 8051, which are also included. For homegrown software development our full platform and OS independent switch API is supplied.

Accompanying the software systems are the Vitesse Switch Reference Systems. These are production-ready hardware designs that also serve as evaluation platforms for our switches.

The Vitesse Solution is supplied with a comprehensive collateral package, which includes software source code, full documentation, and an in-depth qualification report for easy pre-evaluation.

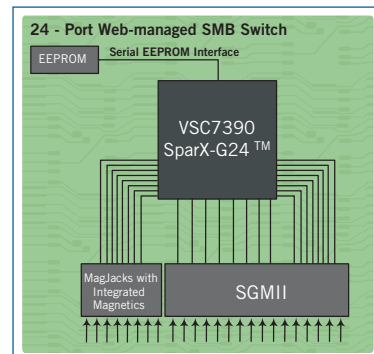

## Features

- Twenty-four Gigabit Ethernet ports with non-blocking wire-speed performance
- Eight integrated tri-speed (10/100/1000 Mbps) copper transceivers (IEEE 802.3ab compliant) and 16 tri-speed SGMII ports
- 500 kb on-chip frame buffer
- Per-port data rate and shaper policer with a granularity of 64 kbps for both ingress and egress direction
- Selection between on-chip V-Core CPU or off-chip 8-bit or 16-bit CPU for fully managed applications
- DSCP remarking for both IPv4 and IPv6 frames
- Jumbo frame support on all ports
- Programmable classifier for QoS, including IEEE 802.1p and DSCP for IPv4 and IPv6, with four classes of service
- 8 k MAC addresses and 4 k VLANs (IEEE 802.1Q)
- Flexible link aggregation compliant to IEEE 802.3ad
- Full-duplex flow control (IEEE 802.3x) and half-duplex back pressure, symmetric and asymmetric
- Multicast and broadcast storm control as well as flooding control
- Vitesse VeriPHY™ cable diagnostics
- Multiple protocol support: IEEE 802.1D, IEEE 802.1w, IEEE 802.1s and IEEE 802.1X

## Benefits

- Ensures maximum data throughput on even highly loaded networks
- Reduces eight external PHYs thereby significantly reducing the overall systems cost – by only needing two external octal PHYs
- Eliminates the need for external buffer memory while maintaining high peak load performance
- Enables pre-arranged bandwidth control and billing
- Enables advanced switch management using run-time protocols, in addition to low-cost unmanaged and web-managed operation
- Enables LAN edge products to generate standard priority which can be used in the core network
- Provides the support of frame sizes up to 12.2 k sized jumbo frames
- Optimizes network performance to support any digital stream, from internet browsing to VoIP and video
- Stores a large amount of stations at wire-speed in the on-chip MAC table, ensuring optimal network performance
- Provides high bandwidth uplinking abilities
- Ensures loss-less data transmission while supporting existing legacy Ethernet equipment
- Eliminates unwanted flooding of ports and thereby increases overall network performance
- Enables sophisticated real time cable diagnostics
- Supports complex network topologies with fast failure recovery and access control

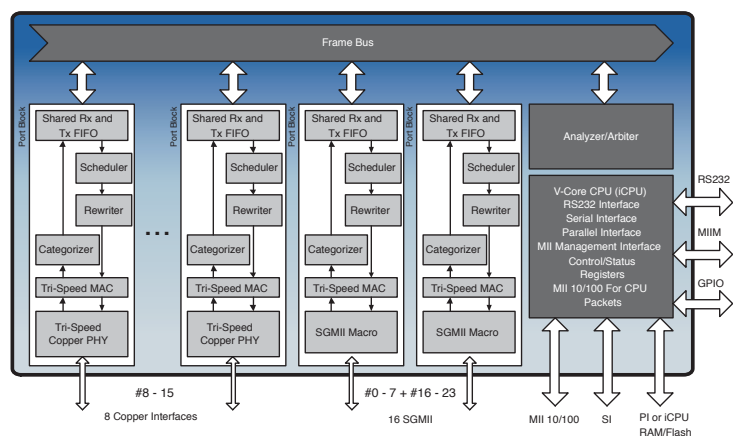

## Related Vitesse Products

Visit [www.vitesse.com](http://www.vitesse.com) for information about other related Vitesse products.



741 Calle Plano • Camarillo, CA 93012 USA • Tel: +1.800.VITESSE • +1.805.388.3700 • Fax: +1.805.987.5896 • [www.vitesse.com](http://www.vitesse.com)

**Vitesse Semiconductor Corporation**