



USB Floppy Disk Controller

FEATURES

- 3.3 Volt, Low Power Operation
- Complete USB Specification 1.1 Compatibility
 - Includes USB Transceiver
 - Based on an Enhanced Version of SMSC's Industry Proven USB97C100 USB Controller
- Complete System Solution Including USB Mass Storage Class Compliant Win98/2000 Driver and Firmware
 - Supports 640K, 720K, 1.44M, 1.2M Windows 98 J, and 1.2M NEC DOS 6.x Formats
 - Supports Both the UFI and SFF8070i Command Sets
 - Supports USB Mass Storage Compliant Bootable Floppy BIOS
 - 4ms Seek Times
 - USB 1.1 Compliance, Including Low Power Device Class SUSPEND Mode Operation and Power Control of Disk Drive
 - Disk Drive Feedback of Readiness Upon Power Re-Application Option
 - Option for Ultra High Performance Using Additional Caching SRAM
 - Support for Floppy Drive Power Control
- Contains SMSC's Industry Proven Floppy Disk Controller
 - Licensed CMOS 765B Floppy Disk Controller
 - Supports Single Normal or Three Mode Floppy Drives
 - Supports Vertical Recording Format and High Capacity Drives in User Written Firmware Applications
 - Detects All Overrun and Underrun Conditions
 - Sophisticated Power Control Circuitry (PCC) Including Multiple Powerdown Modes for Reduced Power Consumption
- Enhanced Digital Data Separator
 - 1 Mbps, 500 Kbps, 300 Kbps, 250 Kbps Data Rates
 - Programmable Precompensation Modes
- Intelligent Auto Power Management
 - <250 μ A SUSPEND Current
 - <75mA Operating Current
- Integrated 32Kbyte Program ROM
 - Uses external 3 wire serial EEPROM provides storage for unique OEM identification and string descriptors and drive option settings.
 - 10 options for various drive parameters are externally selectable via serial EEPROM data.
- Optional External Program Memory Interface for Custom Applications
 - 32K Byte Code Space
 - Flash, SRAM, or EPROM Memory
- 4KB Internal Buffer SRAM for High Performance Operation
- Integrated 14.318 MHz Crystal Driver Circuit
- 100 pin TQFP package (12.0 x 12.0 mm body)
 - 25% smaller body size than other 100 pin TQFP packages

ORDERING INFORMATION

Order Number:

USB97CFDC2-MN-01X
100 Pin TQFP Package



80 Arkay Drive
Hauppauge, NY 11788
(631) 435-6000
FAX (631) 273-3123

Copyright © SMSC 2004. All rights reserved.

Circuit diagrams and other information relating to SMSC products are included as a means of illustrating typical applications. Consequently, complete information sufficient for construction purposes is not necessarily given. Although the information has been checked and is believed to be accurate, no responsibility is assumed for inaccuracies. SMSC reserves the right to make changes to specifications and product descriptions at any time without notice. Contact your local SMSC sales office to obtain the latest specifications before placing your product order. The provision of this information does not convey to the purchaser of the described semiconductor devices any licenses under any patent rights or other intellectual property rights of SMSC or others. All sales are expressly conditional on your agreement to the terms and conditions of the most recently dated version of SMSC's standard Terms of Sale Agreement dated before the date of your order (the "Terms of Sale Agreement"). The product may contain design defects or errors known as anomalies which may cause the product's functions to deviate from published specifications. Anomaly sheets are available upon request. SMSC products are not designed, intended, authorized or warranted for use in any life support or other application where product failure could cause or contribute to personal injury or severe property damage. Any and all such uses without prior written approval of an Officer of SMSC and further testing and/or modification will be fully at the risk of the customer. Copies of this document or other SMSC literature, as well as the Terms of Sale Agreement, may be obtained by visiting SMSC's website at <http://www.smcs.com>. SMSC is a registered trademark of Standard Microsystems Corporation ("SMSC"). Product names and company names are the trademarks of their respective holders.

SMSC DISCLAIMS AND EXCLUDES ANY AND ALL WARRANTIES, INCLUDING WITHOUT LIMITATION ANY AND ALL IMPLIED WARRANTIES OF MERCHANTABILITY, FITNESS FOR A PARTICULAR PURPOSE, TITLE, AND AGAINST INFRINGEMENT AND THE LIKE, AND ANY AND ALL WARRANTIES ARISING FROM ANY COURSE OF DEALING OR USAGE OF TRADE.

IN NO EVENT SHALL SMSC BE LIABLE FOR ANY DIRECT, INCIDENTAL, INDIRECT, SPECIAL, PUNITIVE, OR CONSEQUENTIAL DAMAGES; OR FOR LOST DATA, PROFITS, SAVINGS OR REVENUES OF ANY KIND; REGARDLESS OF THE FORM OF ACTION, WHETHER BASED ON CONTRACT; TORT; NEGLIGENCE OF SMSC OR OTHERS; STRICT LIABILITY; BREACH OF WARRANTY; OR OTHERWISE; WHETHER OR NOT ANY REMEDY OF BUYER IS HELD TO HAVE FAILED OF ITS ESSENTIAL PURPOSE, AND WHETHER OR NOT SMSC HAS BEEN ADVISED OF THE POSSIBILITY OF SUCH DAMAGES.

1 GENERAL DESCRIPTION

The USB97CFDC2-01 is an integration of an Enhanced Multi-Endpoint USB 1.1 Peripheral Controller, a 32K Byte Program ROM, and the SMSC Floppy Disk Controller used in many of its Super IO products, such as the FDC37C869. Special care in the design has been taken to assure the lowest possible system current draw (<250 μ A) during SUSPEND mode operation.

Provisions for external program Flash Memory up to 32K bytes for program storage is provided for customized applications.

Several pins are provided for controlling external power control elements and sensing specialized drive functions. Individual manufacturers may provide their unique USB vendor and product IDs and descriptor strings via an external 3 wire serial EEPROM. Up to 16 different configuration options for various drive related parameters are provided by 4 external configuration input pins which can be read at power-on reset.

TABLE OF CONTENTS

1	GENERAL DESCRIPTION	3
2	DESCRIPTION OF PIN FUNCTIONS.....	5
3	PIN CONFIGURATION.....	6
4	BLOCK DIAGRAM.....	7
5	PIN DESCRIPTIONS.....	8
5.1	BUFFER TYPE DESCRIPTIONS	11
6	CONFIGURATION OPTIONS.....	12
7	BOARD TEST MODE OPERATION	14
8	DC PARAMETERS.....	15
9	AC PARAMETERS.....	17
10	USB PARAMETERS.....	19
10.1	USB DC PARAMETERS	19
10.2	USB AC PARAMETERS	21
11	MECHANICAL OUTLINE.....	24

2 DESCRIPTION OF PIN FUNCTIONS

FLOPPY DISK INTERFACE (14 Pins)			
nTRK0	nINDEX	nWRTPRT	nDSKCHG
nRDATA	DRV DEN0	DRV DEN1	nSTEP
nWDATA	nWGATE	nHDSEL	nDIR
nDSO	nMTR0		
USB INTERFACE (4 Pins)			
USB+	USB-	AVDD	AGND
EXTERNAL FLASH ROM INTERFACE (26 Pins)			
FD0/OPT0	FD1/OPT1	FD2/OPT2	FD3/OPT3
FD4/IN0	FD5/OUT0	FD6/OUT1	FD7/OUT2
FA0	FA1	FA2	FA3
FA4	FA5	FA6	FA7
FA8	FA9	FA10	FA11
FA12	FA13	FA14	FA15
nFRD	nFCE		
MISC (10 Pins)			
ROMEN	HDO	nDRVRDY	nFDPWR
XTAL1/CLKIN	XTAL2	nRESET	nTEST
TST_OUT	nTESTEN		
POWER, GROUNDS, and NO CONNECTS (46 Pins)			

3 PIN CONFIGURATION

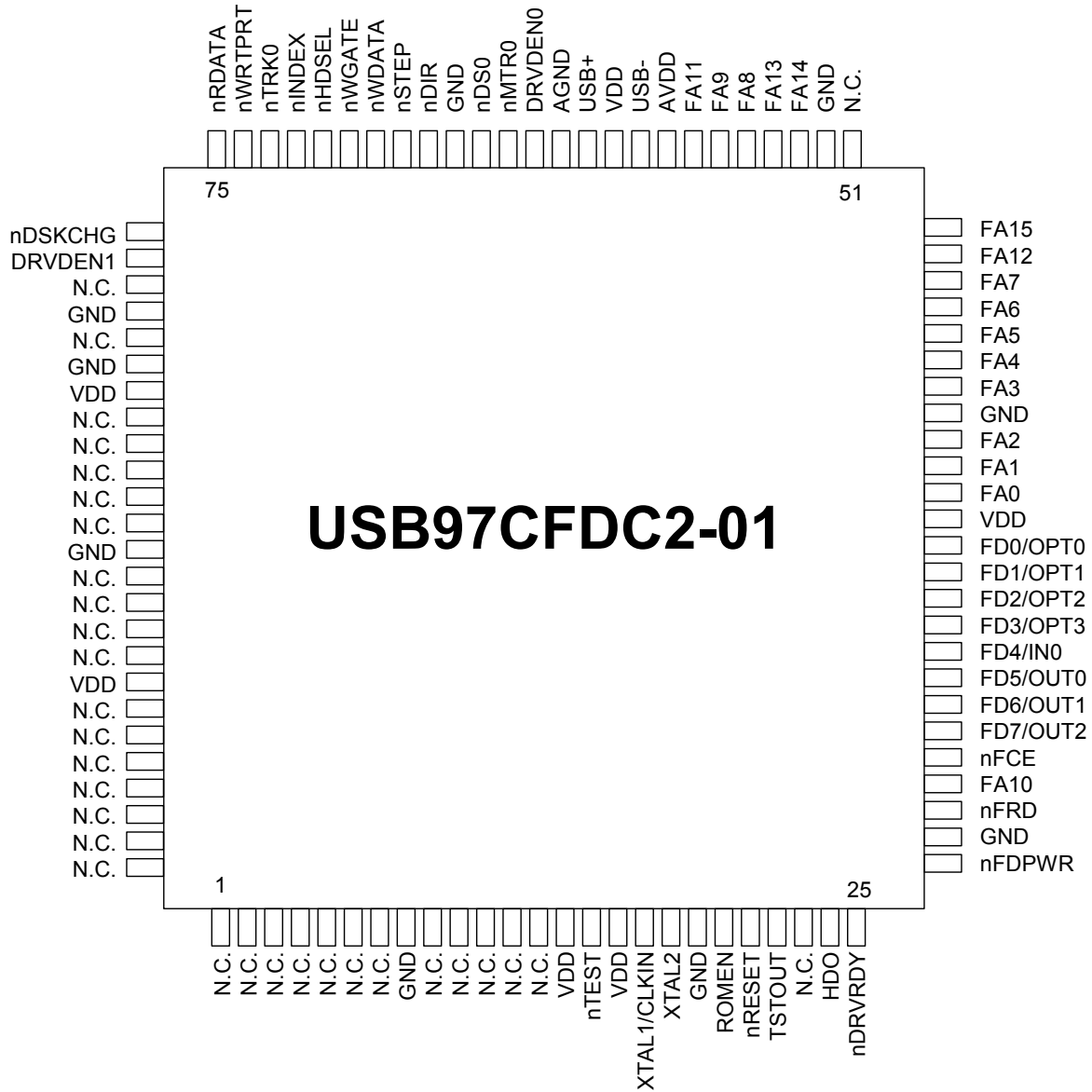

4 BLOCK DIAGRAM

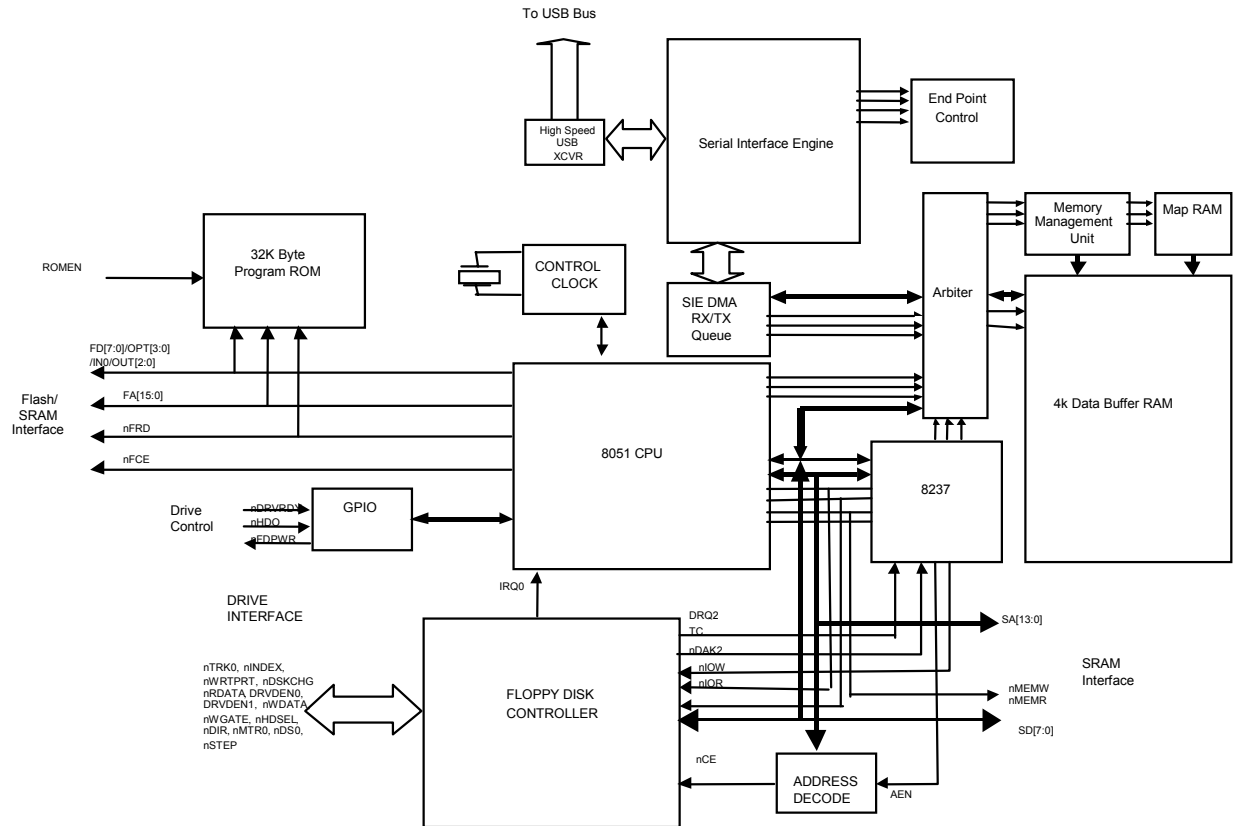

5 PIN DESCRIPTIONS

PIN NO.	NAME	SYMBOL	BUFFER TYPE	DESCRIPTION
FLOPPY DISK INTERFACE				
75	Read Disk Data	nRDATA	IS	Raw serial bit stream from the disk drive, low active. Each falling edge represents a flux transition of the encoded data.
69	Write Data	nWDATA	OD12	This active low high current driver provides the encoded data to the disk drive. Each falling edge causes a flux transition on the media. This pin is high impedance when nRESET is active low.
71	Head Select	nHDSEL	OD12	This high current output selects the floppy disk side for reading or writing. A logic "1" on this pin means side 0 will be accessed, while a logic "0" means side 1 will be accessed. This pin is high impedance when nRESET is active low.
67	Direction Control	nDIR	OD12	This high current low active output determines the direction of the head movement. A logic "1" on this pin means outward motion, while a logic "0" means inward motion. This pin is high impedance when nRESET is active low.
68	Step Pulse	nSTEP	OD12	This active low high current driver issues a low pulse for each track-to-track movement of the head. This pin is high impedance when nRESET is active low.
76	Disk Change	nDSKCHG	IS	This input senses that the drive door is open or that the diskette has possibly been changed since the last drive selection.
63	DRV DEN 0	DRV DEN 0	OD12	An active low on this pin indicates a disk drive spindle speed change from 300 RPM to 360 RPM or 1.2M format disks in three mode drives. This pin should be tied to the disk drives spindle speed control input pin. This pin is high impedance when nRESET is active low.
77	DRV DEN 1	DRV DEN 1	OD12	Reserved for future use.
70	Write Gate	nWGATE	OD12	This active low high current driver allows current to flow through the write head. It becomes active just prior to writing to the diskette. This pin is high impedance when nRESET is active low.
73	Track 0	nTRK0	IS	This active low Schmitt Trigger input senses from the disk drive that the head is positioned over the outermost track.
72	Index	nINDEX	IS	This active low Schmitt Trigger input senses from the disk drive that the head is positioned over the beginning of a track, as marked by an index hole.
74	Write Protect	nWRTPRT	IS	This active low Schmitt Trigger input senses from the disk drive that a disk is write protected. Any write command is ignored.
64	Motor On 0	nMTR0	OD12	This active low open drain output selects motor drive 0. This pin is high impedance when nRESET is active low.
65	Drive Select 0	nDS0	OD12	This active low open drain output selects drive 0. This pin is high impedance when nRESET is active low.

PIN NO.	NAME	SYMBOL	BUFFER TYPE	DESCRIPTION
USB INTERFACE				
59 61	USB Bus Data	USB- USB+	IO-U	These pins connect to the USB data signals through 33 ohm series resistors. The USB+ line should be pulled up with a 5%, 1.5K ohm resistor to indicate that this is a high speed USB device.
58	USB Transceiver Supply	AVDD		This is the 3.3V supply to the internal USB transceiver.
62	USB Transceiver Ground	AGND		This is the supply ground for the internal USB transceiver.
PROGRAM MEMORY INTERFACE				
38-35	Program Memory Data Bus/Option Select	FD[3:0]/ OPT[3:0]	IO8	These signals are used to transfer data between the internal 8051 and the external program memory when operating in external program memory mode (See ROMEN pin). When operating from internal program memory, the OPT3 pin must be tied high thru a resistor and the OPT[2:0] pins tied low thru a resistor (See configuration description section). These pins are not driven while the USB97CFDC2-01 is in SUSPEND mode and internal ROM mode is active. They are driven while in SUSPEND in external ROM mode..
34	Program Memory Data Bus/EEPROM Input	FD4/IN0	IO8	This signal is used to transfer data between the internal 8051 and the external program memory when operating in external program memory mode (See ROMEN pin). When operating from internal program memory, this pin is the input data from an external serial EEPROM that contains manufacturer specific ID and string information, as required by the USB specification, and drive options. This pin is not driven while the USB97CFDC2-01 is in SUSPEND mode and internal ROM mode is active. It is driven while in SUSPEND in external ROM mode...
33-31	Program Memory Data Bus/EEPROM Output	FD[7:5]/ OUT[2:0]	IO8	This signal is used to transfer data between the internal 8051 and the external program memory when operating in external program memory mode (See ROMEN pin). When operating from internal program memory, these pins are the output data and strobcs to an external serial EEPROM that contains manufacturer specific ID and string information, as required by the USB specification, and drive options. These pins are driven while the USB97CFDC2-01 is in SUSPEND mode.
50, 53, 54, 49, 57, 29, 56, 55, 48- 44, 42-40,	Flash Memory Address Bus	FA[15:0]	O8	These signals address memory locations within the FLASH memory.
28	Flash Memory Read Strobe	nFRD	O8	Flash ROM Read; active low
30	Flash Memory Chip Select	nFCE	O8	Flash ROM Chip Select; active low
MISCELLANEOUS				
17	Crystal Input/External Clock Input	XTAL1/ CLKIN	ICLKx	14.318Mhz Crystal or clock input. This pin can be connected to one terminal of the crystal or can be connected to an external 14.318Mhz clock when a crystal is not used.

PIN NO.	NAME	SYMBOL	BUFFER TYPE	DESCRIPTION
18	Crystal Output	XTAL2	OCLKx	14.318Mhz Crystal This is the other terminal of the crystal, or left open when an external clock source is used to drive XTAL1/CLKIN. It may not be used to drive any external circuitry other than the crystal circuit.
20	ROM Enable	ROMEN	IP	If this input is tied high or left open, the internal program ROM is enabled. If tied low, external program memory can be used for custom applications.
24	Drive Density Output	HDO	I	In some configurations of the USB97CFDC, this drive pin indicates if a 640/720K disk is inserted in the drive. Polarity of this signal is determined by the configuration selected by the OPT[3:0] pins at reset. If this pin is not driven by the drive, it should be tied low.
25	Drive Ready	nDRVRDY	I	An active low signal on this pin from the floppy disk drive, after DS0 goes active, indicates that the system may activate MTR0. If the drive does not supply this signal, this pin should be tied low.
26	Drive Power	nFDPWR	OD24	This active low signal is intended to activate an external power switch, either in the drive or on the system board, to supply power to the floppy disk drive. It is active whenever the USB97CFDC2-01 is not in SUSPEND mode.
21	RESET input	nRESET	IS	This active low signal is used by the system to reset the chip. The active low pulse should be at least 100ns wide.
22	Test output	TSTOUT	O8	This signal is used for testing the chip via an internal XNOR chain. User should normally leave it unconnected.
15	Test input	nTEST	I	This signal is a manufacturing test pin. It should be tied to VDD for normal operation.
16	Test Enable	nTESTEN	I	This active low signal places the device into board test mode using the XNOR chain. For normal operation this pin should be tied high. See Board Test Mode Operation on page 14
POWER, GROUND, AND NO CONNECTS				
14, 39, 60, 82, 93		VDD		+3.3V power
8, 19, 27, 43, 52, 66, 79, 81, 88		GND		Ground Reference
1-7, 9-13, 23, 51, 78, 80, 83-87, 89-92, 94-100		NC		No Connect. These pins should not be connected externally.

5.1 Buffer Type Descriptions

Table 1 - USB97CFDC2-01 Buffer Type Descriptions

BUFFER	DESCRIPTION
I	Input
IP	Input with 30uA pull-up
IS	Input with Schmitt trigger
O8	Output with 8mA drive
IO8	Input/output with 8mA drive
IO8P	Input/output with 8mA drive and 30uA pull-up
OD12	Open drain....12mA sink
O24	Output with 24mA drive
OD24	Open drain....24mA sink
ICLKx	XTAL clock input
OCLKx	XTAL clock output
I/O-U	See Table 6.

6 CONFIGURATION OPTIONS

If ROMEN is tied high, then the internal ROM code is used for operation. If low, then an external memory on the FD bus is used for operational code.

If the internal ROM is used, OPT3 must be tied high and OPT[2:0] must be tied low through a resistor. In this mode, an external serial EEPROM is used to store the OEM's USB assigned VID, their PID, their Product String, and the options for the particular drive connected to the USB97CFDC2-01.

The data in the EEPROM is organized as follows:

Note: If the data is not of the specified length, then fill the length with zeros, following the data.

DEVICE DESCRIPTOR - 18 BYTES

For a device with a VID/PID of 0424/0dc, the Device Descriptor looks like the one below. (Note that the data is separated by carriage returns in the "EEPROM.DAT" file. It is displayed here on a single line for clarity's sake.) The VID/PID occupy byte position 9 through 12.

```
12 0110 01 00 00 00 40 24 04 dc 0f 22 01 01 02 00 01
```

The data in bold are the VID and PID information. Note that the lo and the hi bytes are swapped, as in VendorLo, VendorHi, ProductLo and ProductHi.

LANGUAGE STRING - 4 BYTES

String: 0409 (The language code for English)

EEPROM.DAT: 04 03 09 04 (1st byte is the length, then the string ID, followed by the language ID in little endian.)

MANUFACTURER STRING – 60 BYTES (UNICODE FORMAT)

Example String: SMSC

EEPROM.DAT: 3c 03 53 00 4d 00 53 00 43 00 ... 00 (1st byte is the length, followed by the string ID and the Unicode string itself in little endian.)

PRODUCT STRING – 60 BYTES (UNICODE FORMAT)

Example String: USB FDC

EEPROM.DAT: 3c 03 55 00 53 00 42 00 20 00 46 00 44 00 43 00 ... 00 (Again the 1st byte is the length, followed by the string ID and the Unicode string itself in little endian.)

SERIAL NUMBER STRING – 60 BYTES (UNICODE FORMAT)

String: None

EEPROM.DAT: 3c 03 4e 00 6f 00 6e 00 65 00 ... 00 (Again the 1st byte is the length, followed by the string ID and the Unicode string itself in little endian.)

INQUIRY DATA (IN RESPONSE TO A UFI_INQUIRY REQUEST) - 36 BYTES

Bytes 0 – 7: The values for the 1st 8 bytes of the inquiry data come from Table 10 of the USB Mass Storage Class UFI Command Specification. For the USB floppy device, those bytes should be 00 80 00 01 1f 00 00 00. These bytes do not change.

Bytes 8 – 15: Vendor Information (Example: SMSC)

EEPROM.DAT: 53 4d 53 43 20

Bytes 16 – 31: Product Identification (Example: USB FDD)

EEPROM.DAT: 55 53 42 20 46 44 44 20

Bytes 32 – 35: Product Revision Level (Example: 2.00)

EEPROM.DAT: 32 2e 30 30

ATTRIBUTES – 4 BYTES (OBTAINED FROM SECTION 3.0)

Example: The value for your drive from Table 3- Attributes for the Variants is “0005 0000”
EEPROM.DAT: 00 05 00 00

ATTRIBUTES	TAPE BITS	HDO PIN HIGH	DRVRDY DELAY	DSKCHG DETECT
0014 0000	Not set	2HD	Before motor on	Motor on
C014 0004	Set	2DD	Before motor on	Motor on
0005 0000	Not set	2DD	Before motor on	Motor on
0001 0000	Not set	N/A	Before motor on	Motor on
0087 0000	Not set	2DD	N/A	Motor on
8004 0002	Set	2DD	Before motor on	Motor on
000C 0000	Not set	2HD	After motor on	Motor on
020C 0000	Not set	2HD	After motor on	Motor off
802C 0000	Set	2HD	After motor on	Motor on
33AC 0000	Set	2HD	After motor on	Motor on
0005 0001	Not set	2HD	Before motor on	Motor on
0405 0001	Not set	2HD	Before motor on	Motor off

Notes:

1. The Tape Bits being set place the FDC Controller's data clock separator into a mode which has more spindle speed variation tolerance (for small form factor drives) but slightly less bit jitter tolerance.
2. If the HDO pin is not provided use variant 0001 0000.
3. The DRVRDY delay refers to either delaying the MOTOR ON command until DRVRDY goes active after power up (“Before motor on”) or waiting after the motor on command is given to the drive until DRVRDY is active before issuing a step command to the drive (“After motor on”). This applies only to drives with a DRVRDY pin. For those that do not, the DRVRDY input should be tied high (active) so that this delay is not used.
4. The DSKCHG column refers to whether the drive requires its motor to be on before it will update the DSKCHNG pin or not.

To know more about the format of the Device Descriptor and the Strings please refer to the USB 1.1 Specifications. For information on the UFI Inquiry Data, please refer to the “USB Mass Storage Class UFI Command Specification”.

7 BOARD TEST MODE OPERATION

By driving the nTESTEN pin low, the device will be placed into a special test mode to allow verification of attachment of the device to the circuit board. Every pin except the TSTOUT, XTAL2, and the power and ground pins become an input to an XNOR chain, as shown below, to allow continuity to be tested on the board. This test should individually toggle the state of the trace connected to the pin being examined for continuity, and the TSTOUT pin monitored for toggle of state. If no toggle occurs, either the pin under test is discontinuous, or the TSTOUT pin is not connected on the board

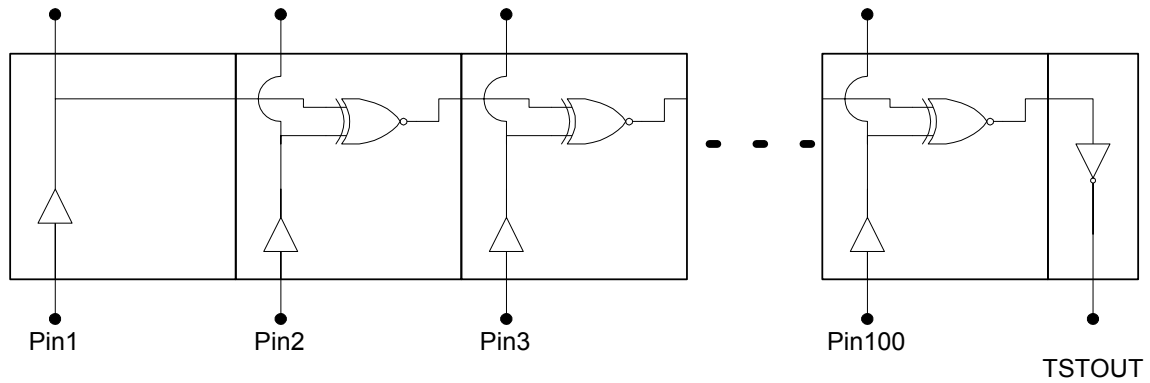

8 DC PARAMETERS

MAXIMUM GUARANTEED RATINGS

Operating Temperature Range	0°C to +70°C
Storage Temperature Range	-55° to +150°C
Lead Temperature Range (soldering, 10 seconds)	+325°C
Positive Voltage on any pin, with respect to Ground (Note 1)	V _{cc} +0.3V
Negative Voltage on any pin, with respect to Ground	-0.3V
Maximum V _{cc}	+3.6V

Note 1: Maximum voltage on all I type Inputs and the IS inputs, OD12 and OD24 outputs for floppy disk drive interface is 5.25V

*Stresses above the specified parameters could cause permanent damage to the device. This is a stress rating only and functional operation of the device at any other condition above those indicated in the operation sections of this specification is not implied.

Note 2: When powering this device from laboratory or system power supplies, it is important that the Absolute Maximum Ratings not be exceeded or device failure can result. Some power supplies exhibit voltage spikes on their outputs when the AC power is switched on or off. In addition, voltage transients on the AC power line may appear on the DC output. When this possibility exists, it is suggested that a clamp circuit be used.

DC ELECTRICAL CHARACTERISTICS (T_A = 0°C - 70°C, V_{cc} = +3.3 V ± 10%)

PARAMETER	SYMBOL	MIN	TYP	MAX	UNITS	COMMENTS
I Type Input Buffer						
Low Input Level	V _{ILI}			0.8	V	TTL Levels
High Input Level	V _{IHI}	2.0			V	
ICLK Input Buffer						
Low Input Level	V _{ILCK}			0.4	V	
High Input Level	V _{IHCK}	2.2			V	
Input Leakage (All I and IS buffers)						
Low Input Leakage	I _{IL}	-10		+10	uA	V _{IN} = 0
High Input Leakage	I _{IH}	-10		+10	uA	V _{IN} = V _{CC}
O8 Type Buffer						
Low Output Level	V _{OL}			0.4	V	I _{OL} = 8 mA
High Output Level	V _{OH}	2.4			V	I _{OH} = -4 mA
Output Leakage	I _{OL}	-10		+10	UA	V _{IN} = 0 to V _{CC} (Note 1)
I/O8(P) Type Buffer						
Low Output Level	V _{OL}			0.4	V	I _{OL} = 8mA
High Output Level	V _{OH}	2.4			V	I _{OH} = -4mA
Output Leakage IO8	I _{OL}	-10		+10	μA	V _{IN} = 0 to V _{cc} (Note 1)
IO8P	I _{OL}	-50		+10	μA	V _{IN} = 0 to V _{cc} (Note 1)

PARAMETER	SYMBOL	MIN	TYP	MAX	UNITS	COMMENTS
OD12 Type Buffer						
Low Output Level	V_{OL}			0.4	V	IOL = 12mA
Output Leakage	I_{OL}	-10		+10	μ A	VIN = 0 to Vcc (Note 1)
O24 Type Buffer						
Low Output Level	V_{OL}			0.4	V	IOL = 24mA
High Output Level	V_{OH}	2.4			V	IOH = -12mA
Output Leakage	I_{OL}	-10		+10	μ A	VIN = 0 to Vcc (Note 1)
OD24 Type Buffer						
Low Output Level	V_{OL}			0.4	V	IOL = 24mA
Output Leakage	I_{OL}	-10		+10	μ A	VIN = 0 to Vcc (Note 1)
IO-U						
Note 2						
Supply Current Active	I_{CC}		30	75	MA	All outputs open.
Supply Current Standby	I_{CSBU}		120	250	μ A	

Note 1: Output leakage is measured with the current pins in high impedance.

Note 2: See Appendix A for USB DC electrical characteristics.

CAPACITANCE $T_A = 25^\circ\text{C}$; $f_c = 1\text{MHz}$; $V_{CC} = 3.3\text{V}$

PARAMETER	SYMBOL	LIMITS			UNIT	TEST CONDITION
		MIN	TYP	MAX		
Clock Input Capacitance	C_{IN}			20	pF	All pins except USB pins (and pins under test tied to AC ground)
Input Capacitance	C_{IN}			10	pF	
Output Capacitance	C_{OUT}			20	pF	

9 AC PARAMETERS

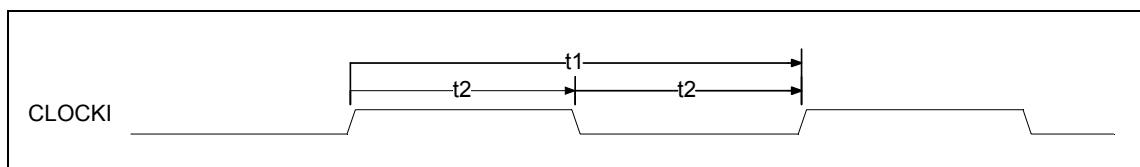

FIGURE 1 - INPUT CLOCK TIMING

Table 2 – Input Clock Timing Parameters

NAME	DESCRIPTION	MIN	TYP	MAX	UNITS
t1	Clock Cycle Time for 14.318MHz		69.84		ns
t2	Clock High Time/Low Time for 24MHz	41.9/ 27.9		27.9/ 41.9	ns
t _r , t _f	Clock Rise Time/Fall Time (not shown)			5	ns

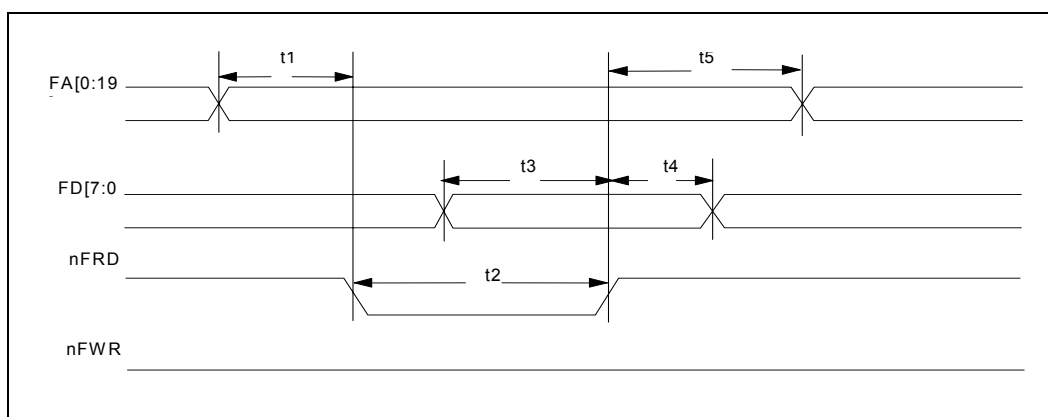

FIGURE 2 – FLASH READ TIMING

Table 3 – Flash Read Timing

NAME	PARAMETER	MIN	TYP	MAX	UNITS
t1	FA[14:0] Address setup time to nFRD asserted	40			ns
t2	nFRD pulse width	110			ns
t3	FD[7:0] Data setup time to nFRD de-asserted	30			ns
t4	FD[7:0] Data hold time from nFRD de-asserted	0			ns
t5	FA[14:0] Address hold time from nFRD de-asserted	35			ns

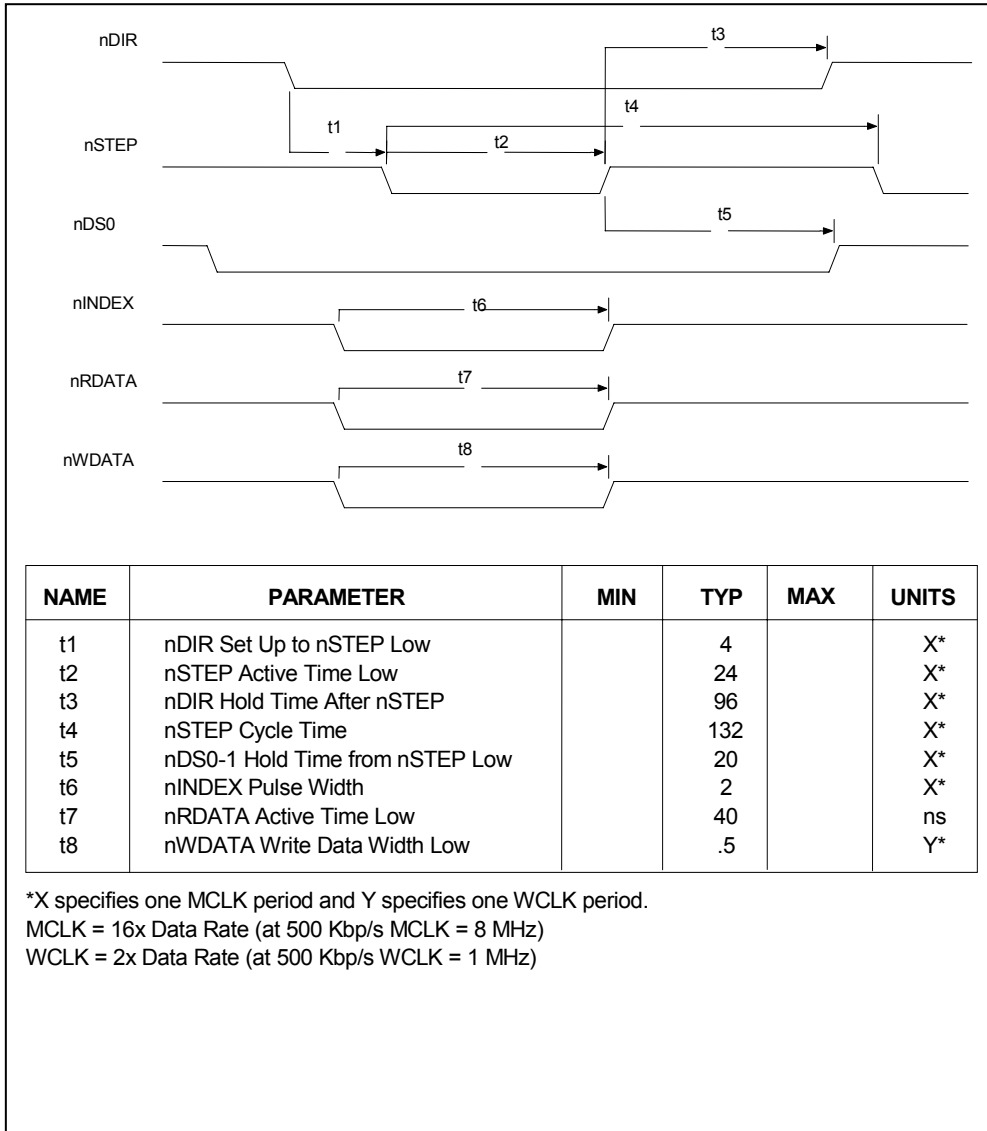

FIGURE 3 - DISK DRIVE TIMING

10 USB PARAMETERS

The following tables and diagrams were obtained from the USB specification

10.1 USB DC PARAMETERS

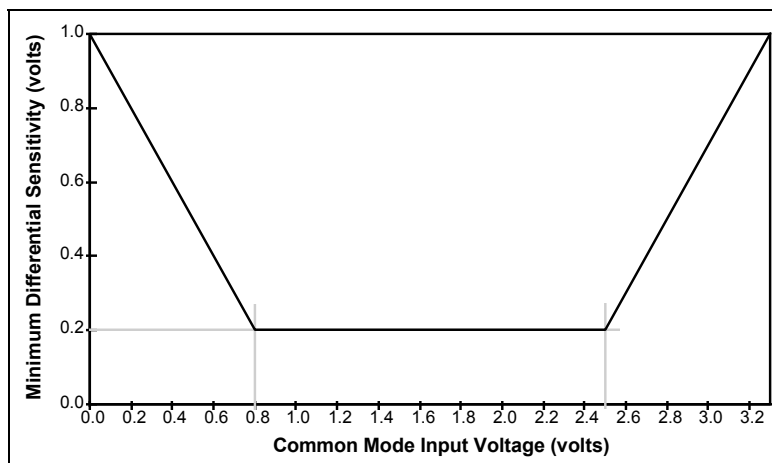

FIGURE 4 - DIFFERENTIAL INPUT SENSITIVITY OVER ENTIRE COMMON MODE RANGE

Table 4 - DC Electrical Characteristics

PARAMETER	SYMBOL	CONDITIONS (NOTE 1, 2)	MIN	TYP	MAX	UNIT
Supply Voltage						
Powered (Host or Hub) Port	VBUS		4.4		5.25	V
Supply Current						
Function	ICC	Note 4			100	mA
Un-configured Function (in)	ICCNIT	Note 5			100	uA
Suspend Device	ICCS				100	uA
Leakage Current						
Hi-Z State Data Line Leakage	ILO	0 V < VIN < 3.3 V	-10		10	uA
Input Levels						
Differential Input Sensitivity	VDI	((D+) - (D-)) , and FIGURE 4	0.2			V
Differential Common Mode Range	VCM	Includes VDI range	0.8		2.5	V
Single Ended Receiver Threshold	VSE		0.8		2.0	V
Output Levels						
Static Output Low	VOL	RL of 1.5 KΩ to 3.6 V			0.3 (3)	V
Static Output High	VOH	RL of 15 KΩ to GND	2.8		3.6 (3)	V
Capacitance						
Transceiver Capacitance	CIN	Pin to GND			20	pF
Terminals						
Bus Pull-up Resistor on Root Port	RPU	(1.5 KΩ +/- 5%)	1.425		1.575	kΩ

PARAMETER	SYMBOL	CONDITIONS (NOTE 1, 2)	MIN	TYP	MAX	UNIT
Bus Pull-down Resistor on Downstream Port	RPD	(15 K Ω +/- 5%)	14.25		15.75	k Ω

Note 1: All voltages are measured from the local ground potential, unless otherwise specified.

Note 2: All timing use a capacitive load (CL) to ground of 50pF, unless otherwise specified.

Note 3: This is relative to VUSBIN.

Note 4: This is dependent on block configuration set by software.

Note 5: When the internal ring oscillator and waiting for first setup packet.

10.2 USB AC PARAMETERS

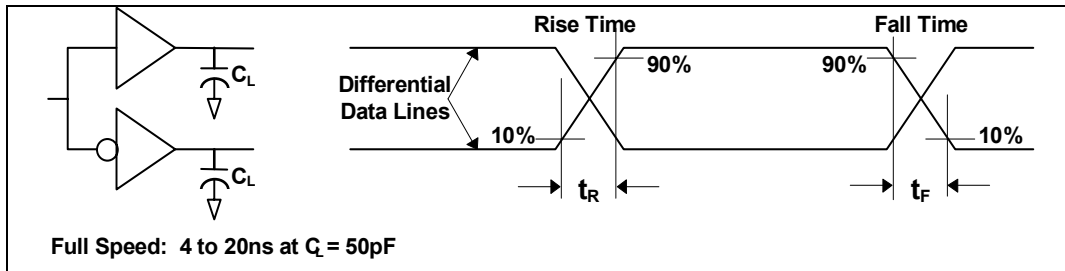

FIGURE 5 - DATA SIGNAL RISE AND FALL TIME

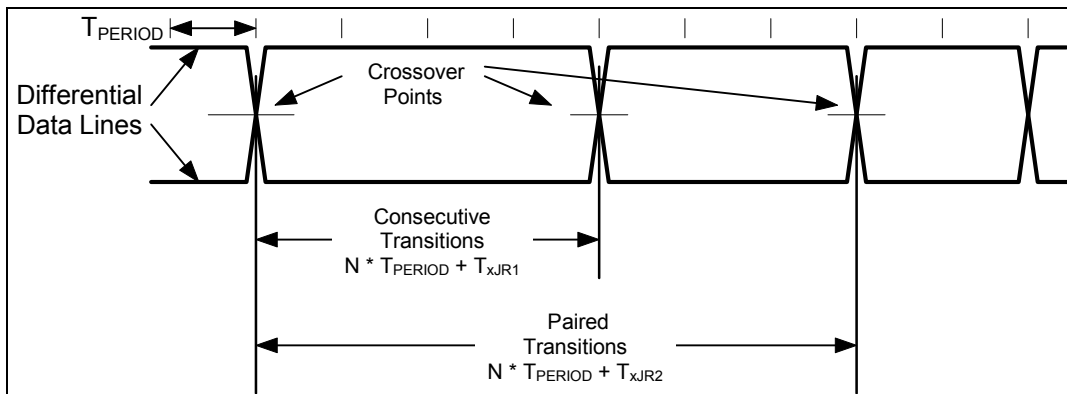

FIGURE 6 - DIFFERENTIAL DATA JITTER

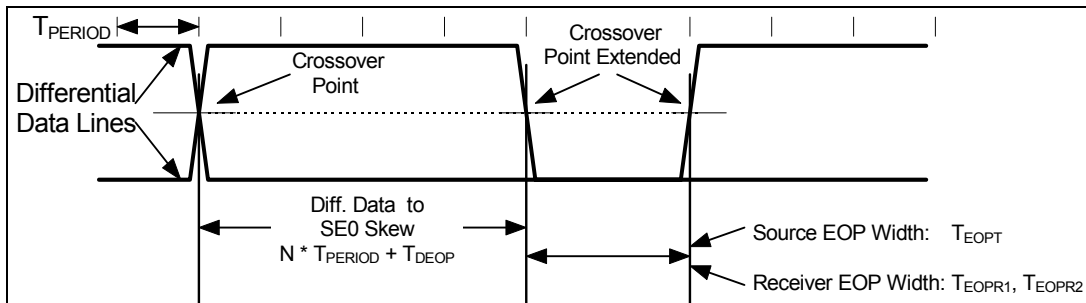

FIGURE 7 - DIFFERENTIAL TO EOP TRANSITION SKEW AND EOP WIDTH

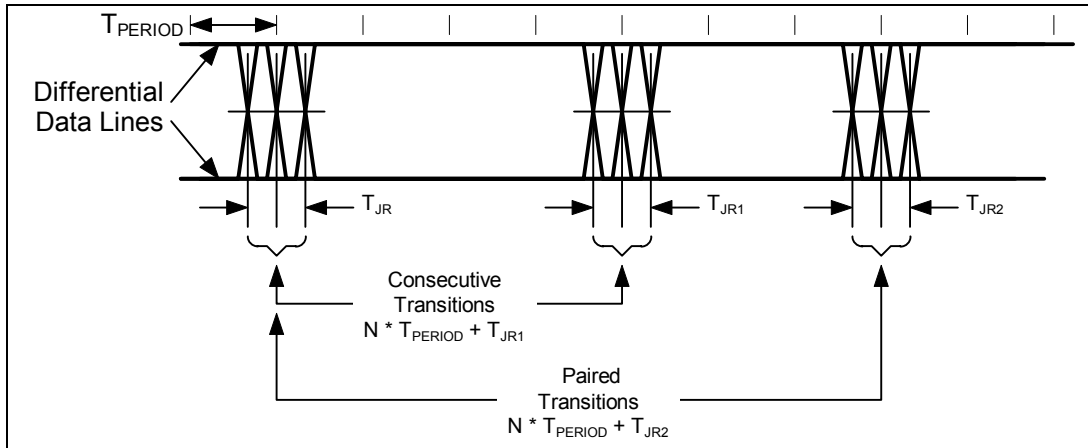

FIGURE 8 - RECEIVER JITTER TOLERANCE

Table 5 - Full Speed (12Mbps) Source Electrical Characteristics

PARAMETER	SYM	CONDITIONS (NOTE 1, 2, 3)	MIN	TYP	MAX	UNIT
Driver Characteristics						
Transition Time:		Note 4,5 and FIGURE 5				
Rise Time	TR	CL = 50 pF	4		20	ns
Fall Time	TF	CL = 50 pF	4		20	ns
Rise/Fall Time Matching	TRFM	(TR/TF)	90		110	%
Output Signal Crossover Voltage	VCRS		1.3		2.0	V
Drive Output Resistance	ZDRV	Steady State Drive	28		43	Ω
Data Source Timing						
Full Speed Data Rate	TDRATE	Ave. Bit Rate (12 Mb/s +/- 0.25%) Note 8	11.95		12.03	Mbs
Frame Interval	TFRAME	1.0 ms +/- 0.05%	0.999 5		1.0005	ms
Source Differential Driver Jitter		Note 6, 7 and FIGURE 6				
To next Transition	TDJ1		-3.5		3.5	ns
For Paired Transitions	TDJ2		-4.0		4.0	ns
Source EOP Width	TEOPT	Note 7 and FIGURE 7	160		175	ns
Differential to EOP transition Skew	TDEOP	Note 7 and FIGURE 7	-2		5	ns
Receiver Data Jitter Tolerance		Note 7 and FIGURE 8				
To next Transition	TJR1		-18.5		18.5	ns
For Paired Transitions	TJR2		-9		9.0	ns
EOP Width at receiver		Note 7 and FIGURE 7				
Must reject as EOP	TEOPR1		40			ns
Must Accept	TEOPR2		82			ns

PARAMETER	SYM	CONDITIONS (NOTE 1, 2, 3)	MIN	TYP	MAX	UNIT
Cable Impedance and Timing						
Cable Impedance (Full Speed)	ZO	(45 Ω +/- 15%)	38.75		51.75	Ω
Cable Delay (One Way)	TCBL				30	ns

Note 1: All voltages are measured from the local ground potential, unless otherwise specified.

Note 2: All timing use a capacitive load (CL) to ground of 50pF, unless otherwise specified.

Note 3: Full speed timings have a 1.5K Ω pull-up to 2.8 V on the D+ data line.

Note 4: Measured from 10% to 90% of the data signals.

Note 5: The rising and falling edges should be smoothly transiting (monotonic).

Note 6: Timing differences between the differential data signals.

Note 7: Measured at crossover point of differential data signals.

Note 8: These are relative to the 14.318 MHz crystal.

11 MECHANICAL OUTLINE

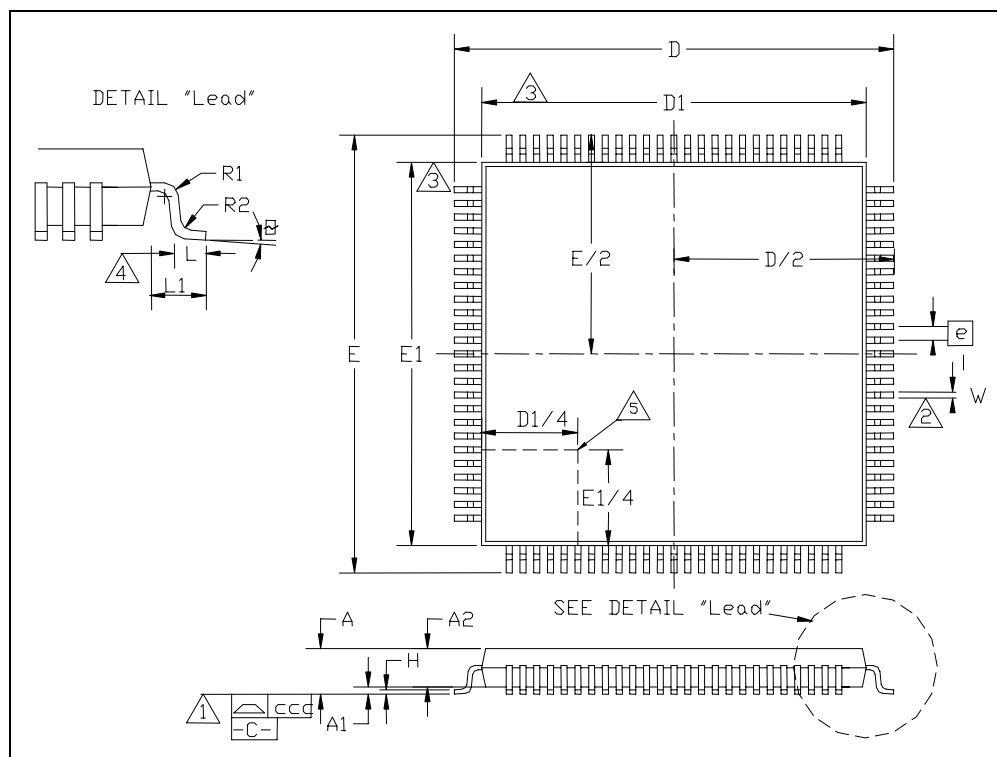

FIGURE 9 - 100 PIN TQFP PACKAGE

	MIN	NOMINAL	MAX	REMARK
A	~	~	1.60	Overall Package Height
A1	0.05	~	0.15	Standoff
A2	1.35	1.40	1.45	Body Thickness
D	13.80	14.00	14.20	X Span
D/2	6.90	7.00	7.10	$\frac{1}{2}$ X Span Measure from Centerline
D1	11.80	12.00	12.20	X body Size
E	13.80	14.00	14.20	Y Span
E/2	6.90	7.00	7.10	$\frac{1}{2}$ Y Span Measure from Centerline
E1	11.80	12.00	12.20	Y body Size
H	0.09	~	0.20	Lead Frame Thickness
L	0.45	0.60	0.75	Lead Foot Length from Centerline
L1	~	1.00	~	Lead Length
e	0.40 Basic			Lead Pitch
θ	0°	3.5°	7°	Lead Foot Angle
W	0.13	0.16	0.23	Lead Width
R1	0.08	~	~	Lead Shoulder Radius
R2	0.08	~	0.20	Lead Foot Radius
ccc	~	~	0.08	Coplanarity

Note 1: Controlling Unit: millimeter

Note 2: Minimum space between protrusion and an adjacent lead is .007 mm.

Note 3: Package body dimensions D1 and E1 do not include the mold protrusion. Maximum mold protrusion is 0.25 mm

Note 5: Details of pin 1 identifier are optional but must be located within the zone indicated.