

32-bit ARM™ Cortex™-M3 based Microcontroller

FM3 MB9AA30N Series

MB9AFA31L/M/N, MB9AFA32L/M/N

■ DESCRIPTION

The MB9AA30N Series are highly integrated 32-bit microcontrollers that dedicated for embedded controllers with low-power consumption mode and competitive cost.

The MB9AA30N Series are based on the ARM Cortex-M3 Processor with on-chip Flash memory and SRAM, and has peripheral functions such as LCD Controller, Motor Control Timers, ADCs, DACs and Communication Interfaces (UART, CSIO, I²C).

The products which are described in this data sheet are placed into TYPE7 product categories in "FM3 Family PERIPHERAL MANUAL".

Note: ARM and Cortex are the trademarks of ARM Limited in the EU and other countries.

ARM™

MB9AA30N Series

■ FEATURES

- 32-bit ARM Cortex-M3 Core
 - Processor version: r2p1
 - Up to 20MHz Operation Frequency
 - Integrated Nested Vectored Interrupt Controller (NVIC): 1 channel NMI (non-maskable interrupt) and 32 channels' peripheral interrupts and 8 priority levels
 - 24-bit System timer (Sys Tick): System timer for OS task management

- On-chip Memories

[Flash memory]

- Up to 128 Kbytes
- Read cycle: 0 wait-cycle
- Security function for code protection

[SRAM]

This series contains a total of up to 16Kbyte on-chip SRAM memories. This is composed of two independent SRAM (SRAM0, SRAM1) . SRAM0 is connected to I-code bus or D-code bus of Cortex-M3 core. SRAM1 is connected to System bus of Cortex-M3 core.

- SRAM0: None
- SRAM1: Up to 16 Kbytes

- LCD controller (LCDC)

- Selectable from 44 SEG × 4 COM (Max) or 40 SEG × 8 COM (Max)
- Internal divide resistor is contained (selectable from 10kΩ or 100kΩ for the resistor value)
- LCD drive power supply (bias) pin (VV4 to VV0)
- Interrupt function synchronized with the LCD module frame frequency
- With blinking function
- Inverted display function

- Multi-function Serial Interface (Max 8channels)

Operation mode is selectable from the followings for each channel.

- UART
- CSIO
- I²C

[UART]

- Full duplex double buffer
- Selection with or without parity supported
- Built-in dedicated baud rate generator
- External clock available as a serial clock
- Various error detection functions available (parity errors, framing errors, and overrun errors)

[CSIO]

- Full duplex double buffer
- Built-in dedicated baud rate generator
- Overrun error detection function available

[I²C]

Standard mode (Max 100kbps) / High-speed mode (Max 400kbps) supported

- A/D Converter (Max 16channels)

- [12-bit A/D Converter]

- Successive Approximation type
 - Conversion time: Min 1.0 μ s
 - Priority conversion available (priority at 2levels)
 - Scanning conversion mode
 - Built-in FIFO for conversion data storage (for SCAN conversion: 16steps, for Priority conversion: 4steps)

- D/A Converter (Max 2channels)

- R-2R type
 - 10-bit resolution

- Base Timer (Max 8channels)

- Operation mode is selectable from the followings for each channel.

- 16-bit PWM timer
 - 16-bit PPG timer
 - 16/32-bit reload timer
 - 16/32-bit PWC timer

- General-Purpose I/O Port

- This series can use its pins as general-purpose I/O ports when they are not used for peripherals. Moreover, the port relocate function is built in. It can set which I/O port the peripheral function can be allocated to.

- Capable of pull-up control per pin
 - Capable of reading pin level directly
 - Built-in the port relocate function
 - Up to 84 high-speed general-purpose I/O Ports@100pin Package
 - Some ports are 5V tolerant I/O

- See "■ LIST OF PIN FUNCTIONS" and "■ I/O CIRCUIT TYPE" to confirm the corresponding pins.

- Multi-function Timer

- The Multi-function timer is composed of the following blocks.

- 16-bit free-run timer \times 3ch.
 - Input capture \times 4ch.
 - Output compare \times 6ch.
 - A/D activating compare \times 3ch.
 - Waveform generator \times 3ch.
 - 16-bit PPG timer \times 3ch.
- IGBT mode is contained.

- The following function can be used to achieve the motor control.

- PWM signal output function
 - DC chopper waveform output function
 - Dead time function
 - Input capture function
 - A/D convertor activate function
 - DTIF (Motor emergency stop) interrupt function

MB9AA30N Series

- **HDMI-CEC/Remote Control Receiver (Up to 2channels)**
 - HDMI- CEC receiver / Remote control receiver
 - Operating modes supporting the following standards can be selected
 - SIRCS
 - NEC/Association for Electric Home Appliances
 - HDMI-CEC
 - Capable of adjusting detection timings for start bit and data bit
 - Equipped with noise filter
 - HDMI-CEC transmitter
 - Header block automatic transmission by judging Signal free
 - Generating status interrupt by detecting Arbitration lost
 - Generating START, EOM, ACK automatically to output CEC transmission by setting 1 byte data
 - Generating transmission status interrupt when transmitting 1 block (1 byte data and EOM/ACK)
- **Real-time clock (RTC)**

The Real-time clock can count Year/Month/Day/Hour/Minute/Second/A day of the week from 01 to 99.

 - The interrupt function with specifying date and time (Year/Month/Day/Hour/Minute/Second/A day of the week.) is available. This function is also available by specifying only Year, Month, Day, Hour or Minute.
 - Timer interrupt function after set time or each set time.
 - Capable of rewriting the time with continuing the time count.
 - Leap year automatic count is available.
- **External Interrupt Controller Unit**
 - Up to 16 external interrupt input pins
 - Include one non-maskable interrupt (NMI) input pin
- **Watchdog Timer (2channels)**

A watchdog timer can generate interrupts or a reset when a time-out value is reached.

This series consists of two different watchdogs, a "Hardware" watchdog and a "Software" watchdog.

The "Hardware" watchdog timer is clocked by the built-in low-speed CR oscillator. Therefore, the "Hardware" watchdog is active in any low-power consumption mode except RTC, STOP, Deep standby RTC and Deep standby STOP modes.

- **Clock and Reset**

[Clocks]

Selectable from five clock sources (2 external oscillators, 2 built-in CR oscillators, and Main PLL).

- Main Clock : 4MHz to 20MHz
- Sub Clock : 32.768kHz
- Built-in high-speed CR Clock : 4MHz
- Built-in low-speed CR Clock : 100kHz
- Main PLL Clock

[Resets]

- Reset requests from INITX pin
- Power-on reset
- Software reset
- Watchdog timers reset
- Low-voltage detection reset
- Clock Super Viser reset

- **Clock Super Visor (CSV)**

Clocks generated by built-in CR oscillators are used to supervise abnormality of the external clocks.

- If external clock failure (clock stop) is detected, reset is asserted.
- If external frequency anomaly is detected, interrupt or reset is asserted.

- **Low-Voltage Detector (LVD)**

This Series includes 2-stage monitoring of voltage on the VCC. When the voltage falls below the voltage that has been set, Low-Voltage Detector generates an interrupt or reset.

- LVD1: error reporting via interrupt
- LVD2: auto-reset operation

- **Low-Power Consumption Mode**

Six low-power consumption modes supported.

- SLEEP
- TIMER
- RTC
- STOP
- Deep standby RTC
- Deep standby STOP

The back up register is 16byte

- **Debug**

Serial Wire JTAG Debug Port (SWJ-DP)

- **Power Supply**

Wide range voltage : VCC = 1.8V to 5.5V
: VCC = 2.2V to 5.5V (when LCDC is used)

MB9AA30N Series

■ PRODUCT LINEUP

• Memory size

Product name		MB9AFA31L/M/N	MB9AFA32L/M/N
On-chip Flash memory		64Kbytes	128Kbytes
On-chip SRAM	SRAM1	12Kbytes	16Kbytes

• Function

Product name		MB9AFA31L MB9AFA32L	MB9AFA31M MB9AFA32M	MB9AFA31N MB9AFA32N
Pin count		64	80	100
CPU		Cortex-M3		
Freq.		20MHz		
Power supply voltage range		1.8V to 5.5V		
LCD Controller (LCDC)		24SEG×4COM (Max) or 20SEG×8COM (Max)	37SEG×4COM (Max) or 33SEG×8COM (Max)	44SEG×4COM (Max) or 40SEG×8COM (Max)
Multi-function Serial Interface (UART/CSIO/I ² C)		8ch. (Max)		
Base Timer (PWC/ Reload timer/PWM/PPG)		8ch. (Max)		
MF-Timer	A/D activation compare	3ch.		
	Input capture	4ch.		
	Free-run timer	3ch.		
	Output compare	6ch.		
	Waveform generator	3ch.		
	PPG (IGBT mode)	3ch.		
HDMI-CEC/ Remote Control Receiver		2ch. (Max)		
Real-time clock (RTC)		1 unit		
Watchdog timer		1ch. (SW) + 1ch. (HW)		
External Interrupts		8pins (Max)+ NMI × 1	11pins (Max) + NMI × 1	16pins (Max) + NMI × 1
General-purpose I/O ports		52pins (Max)	67pins (Max)	84pins (Max)
12-bit A/D converter		9ch. (1 unit)	12ch. (1 unit)	16ch. (1 unit)
10-bit D/A converter		2ch. (Max)		
CSV (Clock Super Visor)		Yes		
LVD (Low-Voltage Detector)		2ch.		
Built-in CR	High-speed	4MHz (± 2%)		
	Low-speed	100kHz (Typ)		
Debug Function		SWJ-DP		

Note: All signals of the peripheral function in each product cannot be allocated by limiting the pins of package. It is necessary to use the port relocate function of the I/O port according to your function use.

MB9AA30N Series

■ PACKAGES

Package	Product name	MB9AFA31L MB9AFA32L	MB9AFA31M MB9AFA32M	MB9AFA31N MB9AFA32N
LQFP: FPT-64P-M38 (0.5mm pitch)		○	-	-
LQFP: FPT-64P-M39 (0.65mm pitch)		○	-	-
QFN: LCC-64P-M24		○	-	-
LQFP: FPT-80P-M37 (0.5mm pitch)		-	○	-
LQFP: FPT-80P-M40 (0.65mm pitch)		-	○	-
LQFP: FPT-100P-M23 (0.5mm pitch)		-	-	○
QFP: FPT-100P-M06 (0.65mm pitch)		-	-	○
BGA: BGA-112P-M04 (0.8mm pitch)		-	-	planning

○ : Supported

Note : See "■PACKAGE DIMENSIONS" for detailed information on each package.

MB9AA30N Series

■ PIN ASSIGNMENT

- FPT-64P-M38/M39

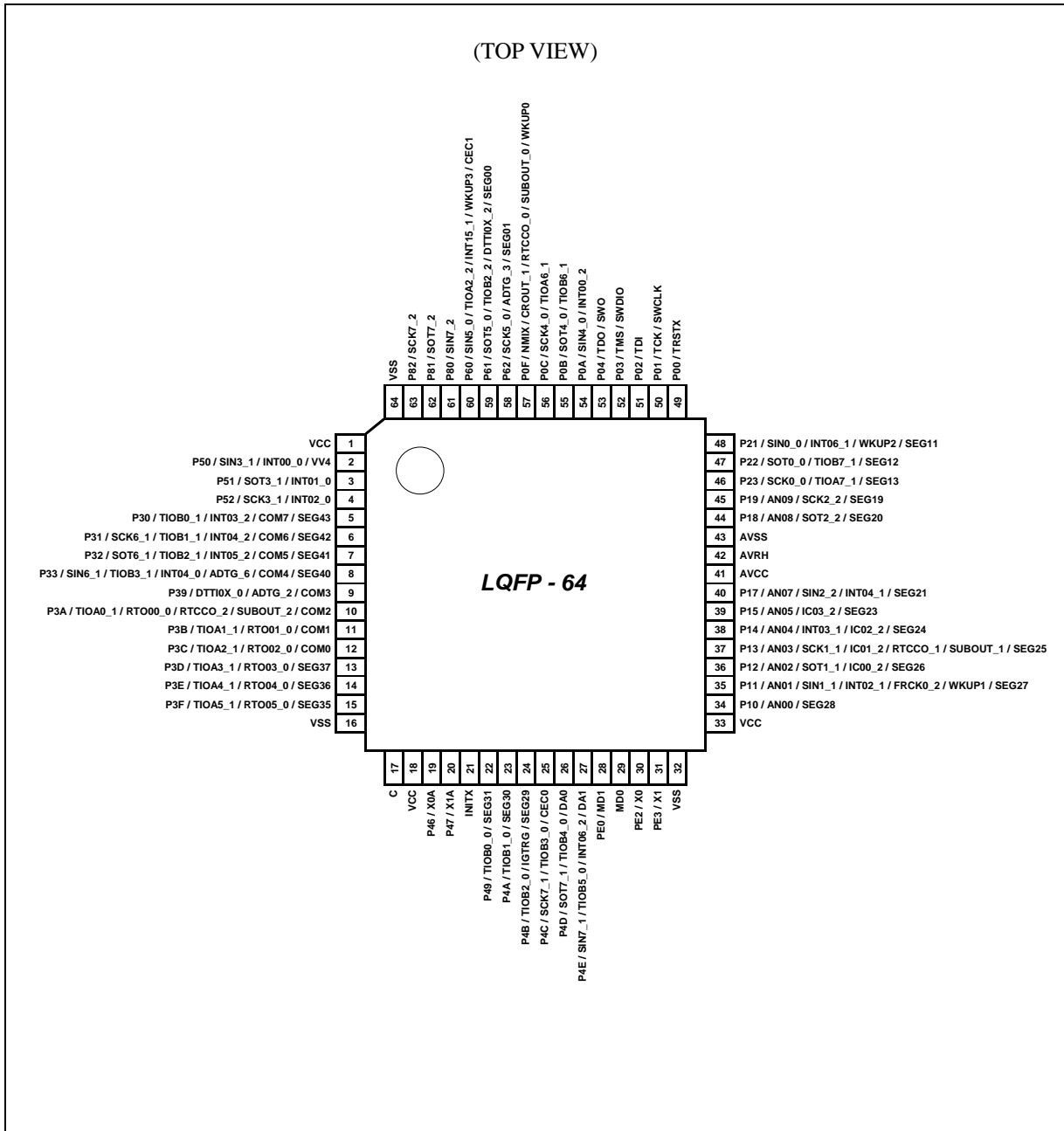

<Note>

The number after the underscore ("_") in pin names such as XXX_1 and XXX_2 indicates the relocated port number. For these pins, there are multiple pins that provide the same function for the same channel. Use the extended port function register (EPFR) to select the pin.

• LCC-64P-M24

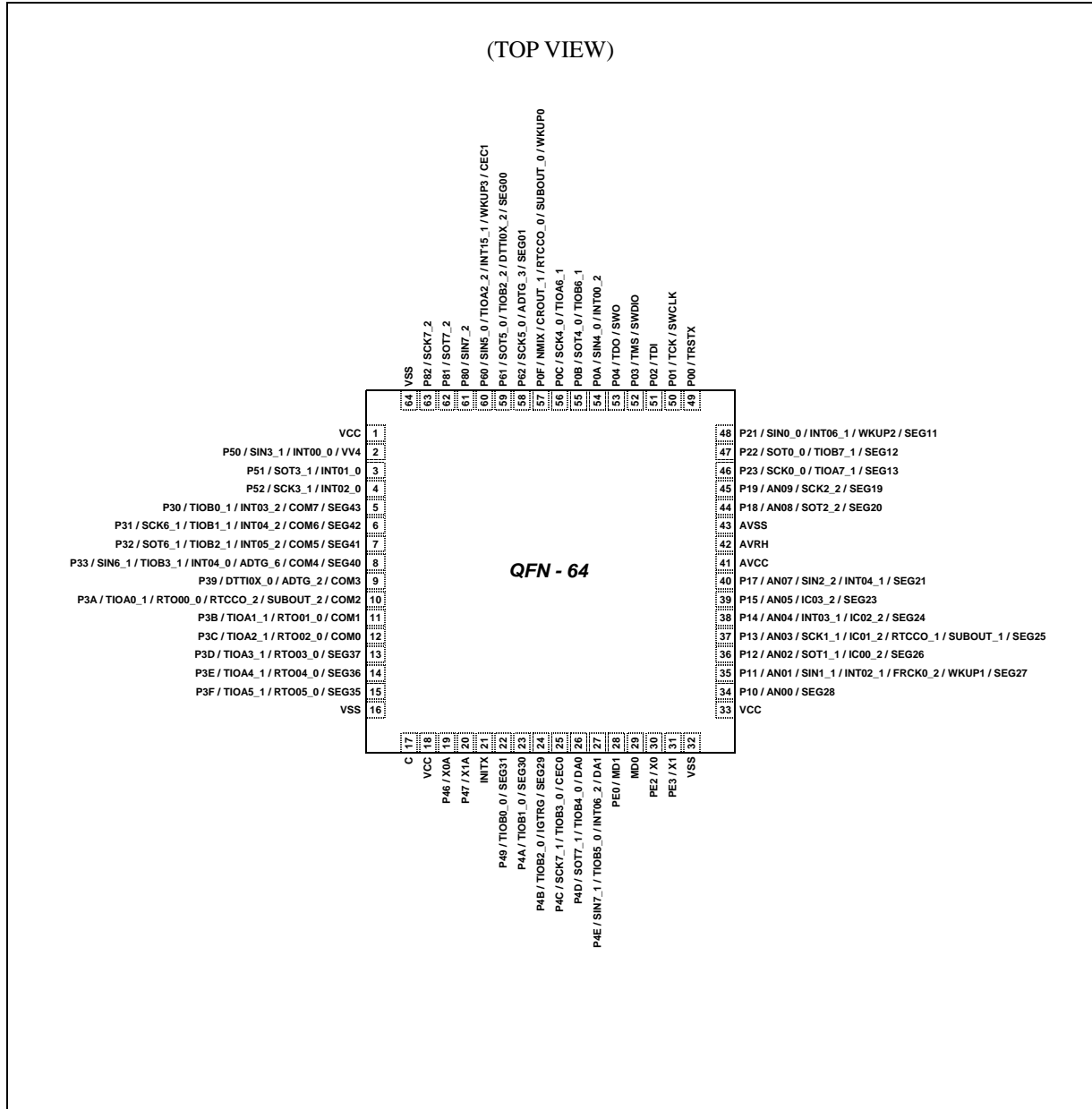

<Note>

The number after the underscore ("_") in pin names such as XXX_1 and XXX_2 indicates the relocated port number. For these pins, there are multiple pins that provide the same function for the same channel. Use the extended port function register (EPFR) to select the pin.

MB9AA30N Series

• FPT-80P-M37/M40

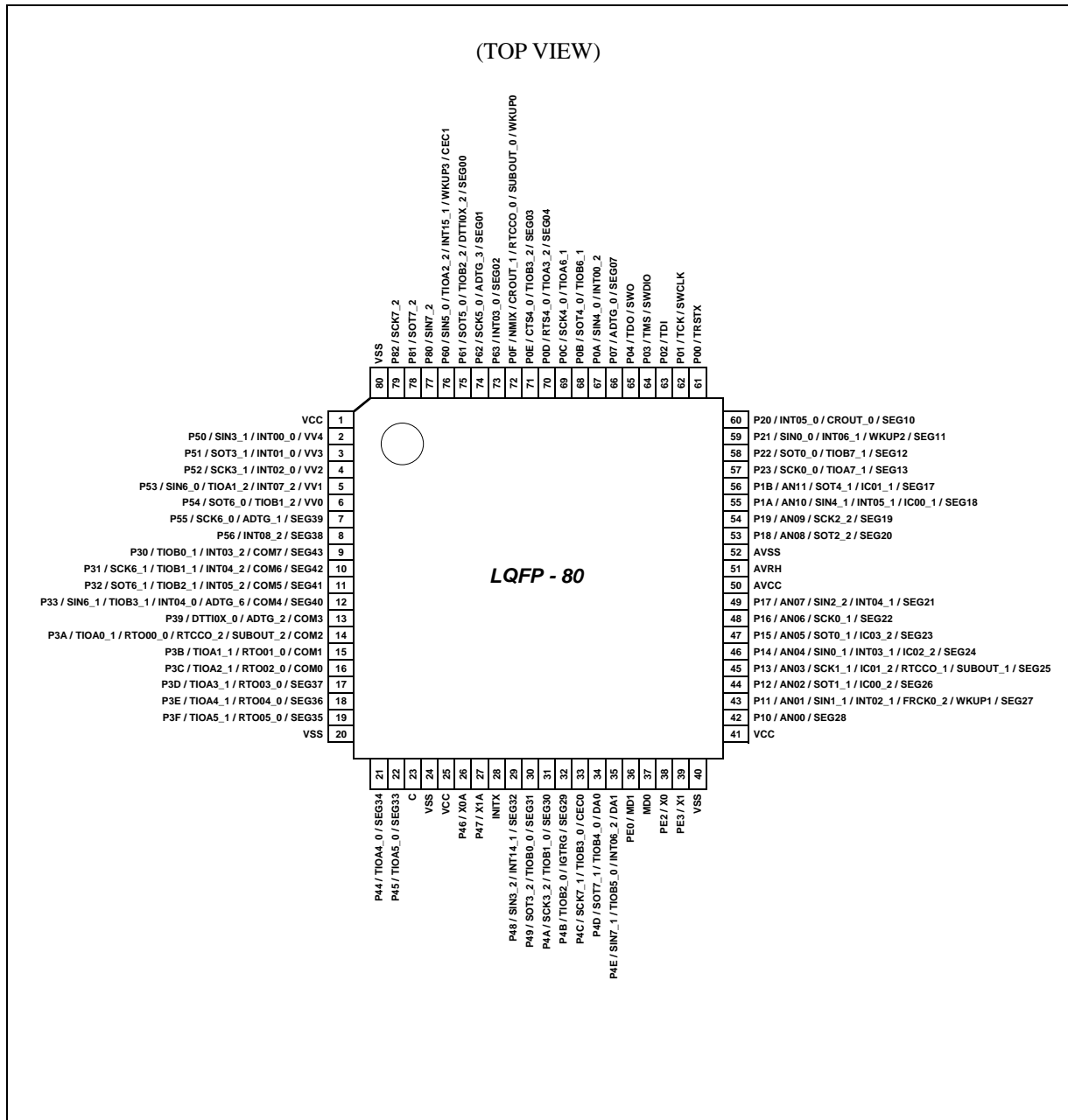

<Note>

The number after the underscore ("_") in pin names such as XXX_1 and XXX_2 indicates the relocated port number. For these pins, there are multiple pins that provide the same function for the same channel. Use the extended port function register (EPFR) to select the pin.

• FPT-100P-M23

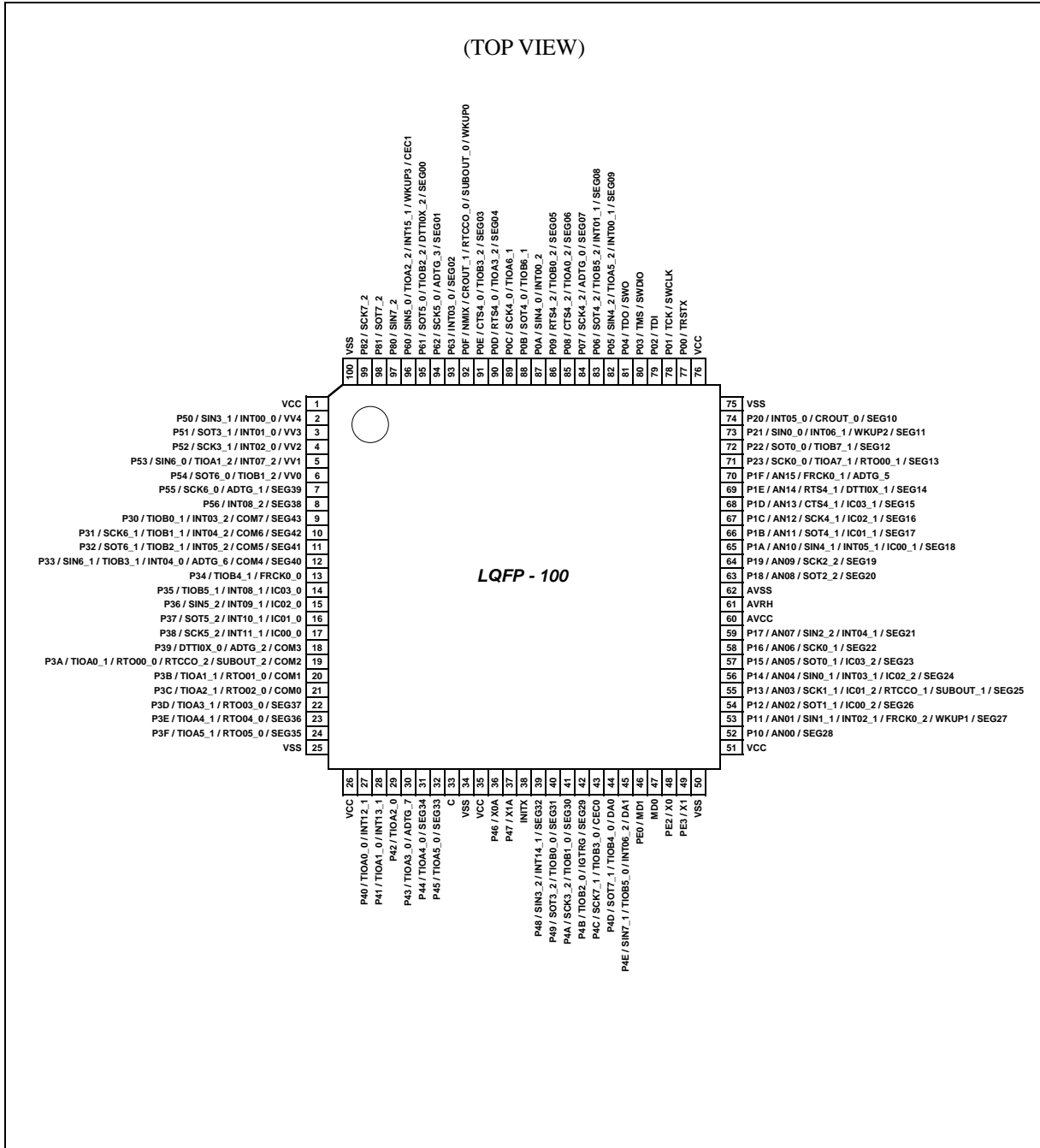

<Note>

The number after the underscore ("_") in pin names such as XXX_1 and XXX_2 indicates the relocated port number. For these pins, there are multiple pins that provide the same function for the same channel. Use the extended port function register (EPFR) to select the pin.

MB9AA30N Series

• FPT-100P-M06

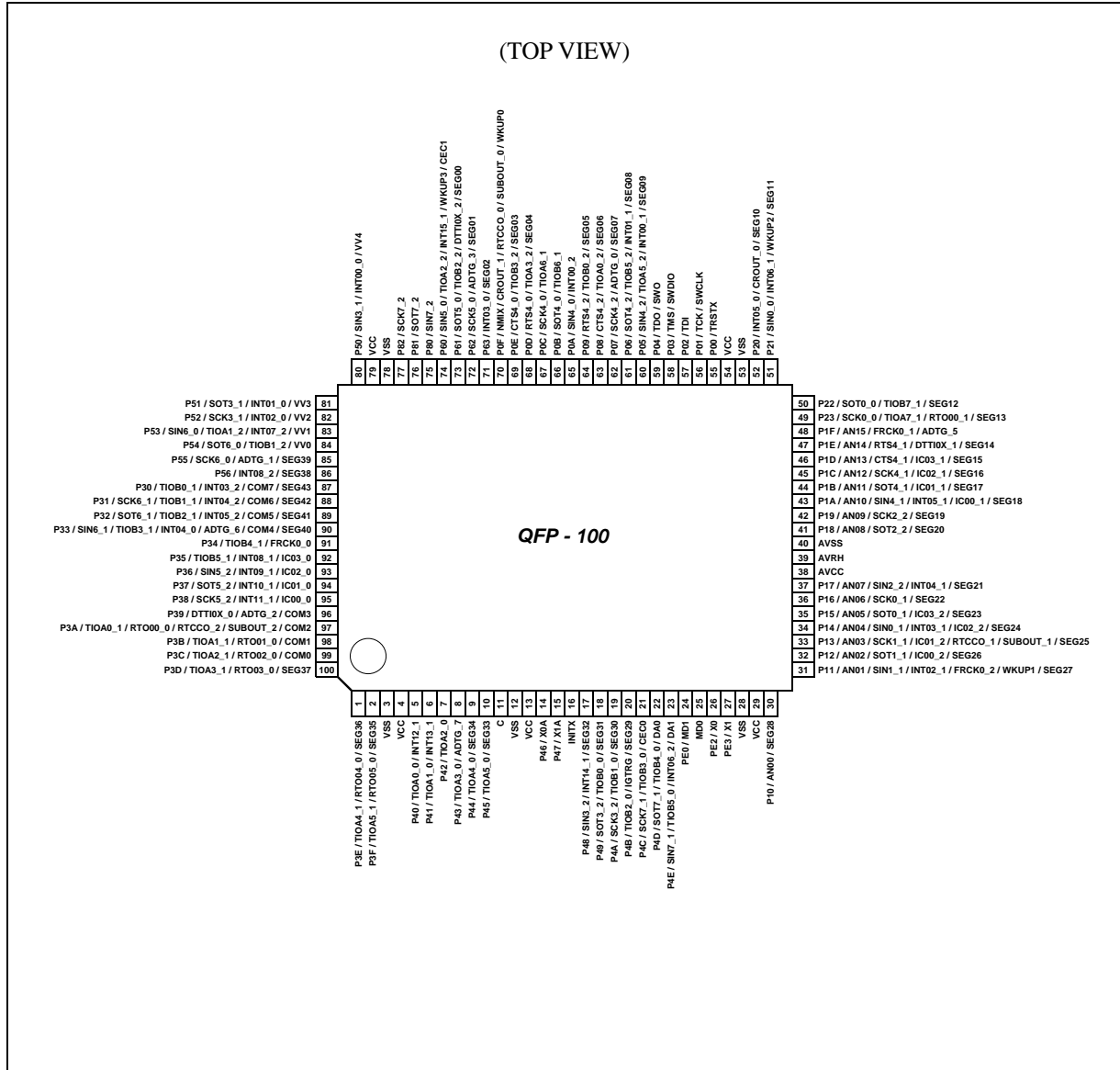

<Note>

The number after the underscore ("_") in pin names such as XXX_1 and XXX_2 indicates the relocated port number. For these pins, there are multiple pins that provide the same function for the same channel. Use the extended port function register (EPFR) to select the pin.

MB9AA30N Series

• BGA-112P-M04

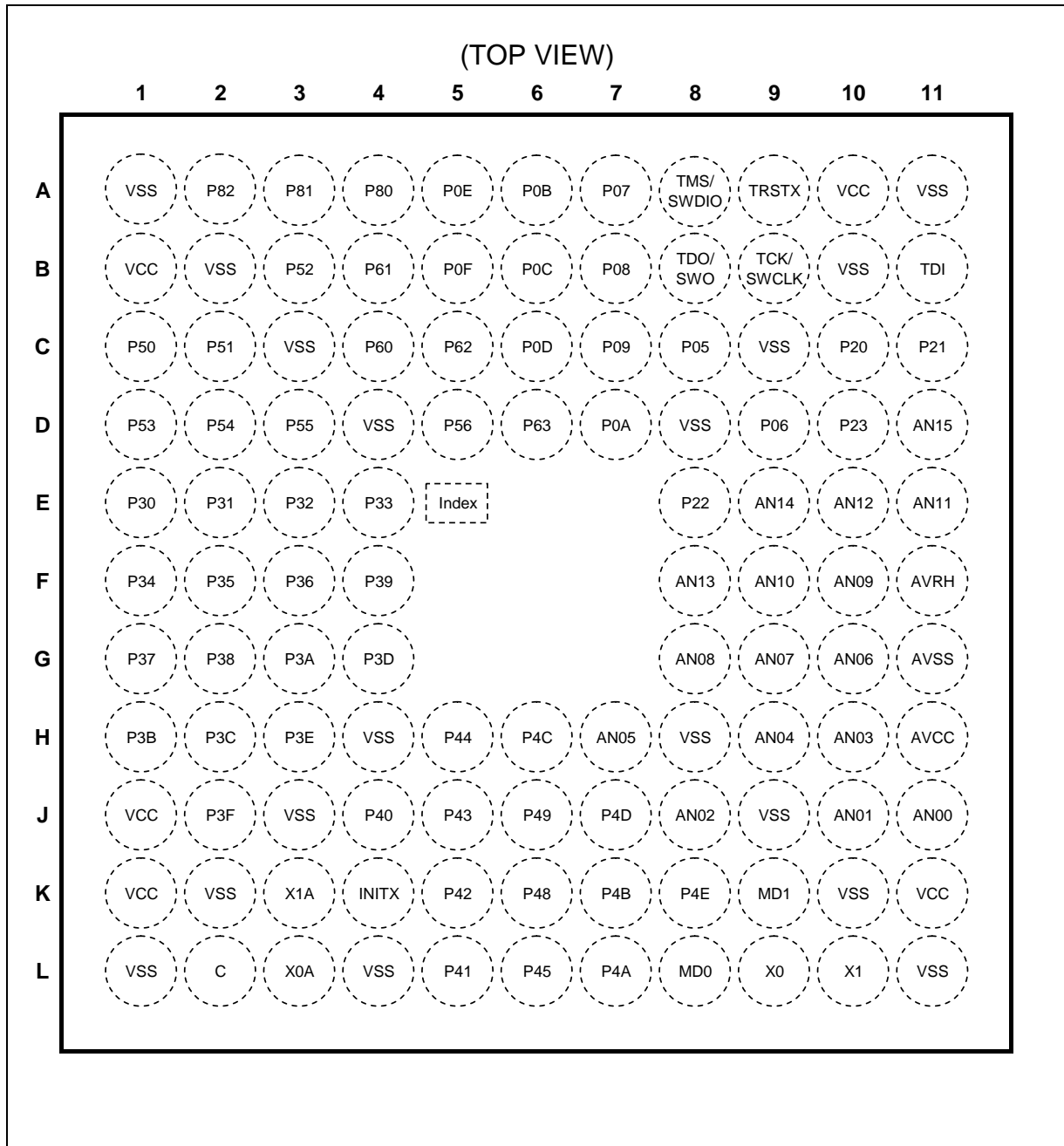

<Note>

The number after the underscore ("_") in pin names such as XXX_1 and XXX_2 indicates the relocated port number. For these pins, there are multiple pins that provide the same function for the same channel. Use the extended port function register (EPFR) to select the pin.

MB9AA30N Series

■ LIST OF PIN FUNCTIONS

- List of pin numbers

The number after the underscore ("_") in pin names such as XXX_1 and XXX_2 indicates the relocated port number. For these pins, there are multiple pins that provide the same function for the same channel. Use the extended port function register (EPFR) to select the pin.

Pin No					Pin name	I/O circuit type	Pin state type
LQFP-64 QFN-64	LQFP-80	LQFP-100	QFP-100	BGA-112			
1	1	1	79	B1	VCC	-	
2	2	2	80	C1	P50	R	W
					INT00_0		
					SIN3_1		
					VV4		
-	3	3	81	C2	P51	R	W
					INT01_0		
					SOT3_1 (SDA3_1)		
					VV3		
3	-	-	-	-	P51	E	F
					INT01_0		
					SOT3_1 (SDA3_1)		
-	4	4	82	B3	P52	R	W
					INT02_0		
					SCK3_1 (SCL3_1)		
					VV2		
4	-	-	-	-	P52	E	F
					INT02_0		
					SCK3_1 (SCL3_1)		
-	5	5	83	D1	P53	R	W
					SIN6_0		
					TIOA1_2		
					INT07_2		
-	6	6	84	D2	P54	R	V
					SOT6_0 (SDA6_0)		
					TIOB1_2		
					VV0		
-	7	7	85	D3	P55	J	U
					SCK6_0 (SCL6_0)		
					ADTG_1		
					SEG39		
-	8	8	86	D5	P56	J	S
					INT08_2		
					SEG38		

MB9AA30N Series

Pin No					Pin name	I/O circuit type	Pin state type
LQFP-64 QFN-64	LQFP-80	LQFP-100	QFP-100	BGA-112			
5	9	9	87	E1	P30	K	S
					TIOB0_1		
					INT03_2		
					COM7		
					SEG43		
6	10	10	88	E2	P31	K	S
					TIOB1_1		
					SCK6_1 (SCL6_1)		
					INT04_2		
					COM6		
					SEG42		
7	11	11	89	E3	P32	K	S
					TIOB2_1		
					SOT6_1 (SDA6_1)		
					INT05_2		
					COM5		
					SEG41		
8	12	12	90	E4	P33	K	S
					INT04_0		
					TIOB3_1		
					SIN6_1		
					ADTG_6		
					COM4		
					SEG40		
-	-	13	91	F1	P34	E	H
					FRCK0_0		
					TIOB4_1		
-	-	14	92	F2	P35	E	F
					IC03_0		
					TIOB5_1		
-	-	15	93	F3	P36	E	F
					IC02_0		
					SIN5_2		
					INT09_1		
-	-	16	94	G1	P37	E	F
					IC01_0		
					SOT5_2 (SDA5_2)		
					INT10_1		

MB9AA30N Series

Pin No					Pin name	I/O circuit type	Pin state type
LQFP-64 QFN-64	LQFP-80	LQFP-100	QFP-100	BGA-112			
-	-	17	95	G2	P38	E	F
					IC00_0		
					SCK5_2 (SCL5_2)		
					INT11_1		
9	13	18	96	F4	P39	L	U
					DTTIOX_0		
					ADTG_2		
10	14	19	97	G3	COM3	L	U
					P3A		
					RTO00_0 (PPG00_0)		
					TIOA0_1		
					RTCCO_2		
					SUBOUT_2		
11	15	20	98	H1	P3B	L	U
					RTO01_0 (PPG00_0)		
					TIOA1_1		
					COM1		
12	16	21	99	H2	P3C	L	U
					RTO02_0 (PPG02_0)		
					TIOA2_1		
13	17	22	100	G4	COM0	J	U
					P3D		
					RTO03_0 (PPG02_0)		
					TIOA3_1		
-	-	-	-	B2	SEG37	-	-
					VSS		
					P3E		
					RTO04_0 (PPG04_0)		
14	18	23	1	H3	TIOA4_1	J	U
					SEG36		
					P3F		
15	19	24	2	J2	RTO05_0 (PPG04_0)	J	U
					TIOA5_1		
					SEG35		
					VSS		
16	20	25	3	L1	VSS	-	-
-	-	26	4	J1	VCC	-	-

MB9AA30N Series

Pin No					Pin name	I/O circuit type	Pin state type
LQFP-64 QFN-64	LQFP-80	LQFP-100	QFP-100	BGA-112			
-	-	27	5	J4	P40	E	F
					TIOA0_0		
					INT12_1		
-	-	28	6	L5	P41	E	F
					TIOA1_0		
					INT13_1		
-	-	29	7	K5	P42	E	H
					TIOA2_0		
-	-	30	8	J5	P43	E	H
					TIOA3_0		
					ADTG_7		
-	21	31	9	H5	P44	J	U
					TIOA4_0		
					SEG34		
-	22	32	10	L6	P45	J	U
					TIOA5_0		
					SEG33		
-	-	-	-	K2	VSS	-	-
-	-	-	-	J3	VSS	-	-
-	-	-	-	H4	VSS	-	-
17	23	33	11	L2	C	-	-
-	24	34	12	L4	VSS	-	-
18	25	35	13	K1	VCC	-	-
19	26	36	14	L3	P46	D	M
					X0A		
20	27	37	15	K3	P47	D	N
					X1A		
21	28	38	16	K4	INITX	B	C
-	29	39	17	K6	P48	J	S
					INT14_1		
					SIN3_2		
					SEG32		
22	30	40	18	J6	P49	J	U
					TIOB0_0		
					SEG31		
-					SOT3_2 (SDA3_2)		
23	31	41	19	L7	P4A	J	U
					TIOB1_0		
					SEG30		
-					SCK3_2 (SCL3_2)		

MB9AA30N Series

Pin No					Pin name	I/O circuit type	Pin state type
LQFP-64 QFN-64	LQFP-80	LQFP-100	QFP-100	BGA-112			
24	32	42	20	K7	P4B	J	U
					TIOB2_0		
					SEG29		
					IGTRG		
25	33	43	21	H6	P4C	G	Q
					TIOB3_0		
					SCK7_1 (SCL7_1)		
					CEC0		
26	34	44	22	J7	P4D	O	Z
					TIOB4_0		
					SOT7_1 (SDA7_1)		
					DA0		
27	35	45	23	K8	P4E	O	Y
					TIOB5_0		
					INT06_2		
					SIN7_1		
28	36	46	24	K9	PE0	C	P
					MD1		
29	37	47	25	L8	MD0	H	D
30	38	48	26	L9	PE2	A	A
					X0		
31	39	49	27	L10	PE3	A	B
					X1		
32	40	50	28	L11	VSS	-	
33	41	51	29	K11	VCC	-	
34	42	52	30	J11	P10	Q	J
					AN00		
					SEG28		
35	43	53	31	J10	P11	Q	L
					AN01		
					SIN1_1		
					INT02_1		
					FRCK0_2		
					WKUP1		
SEG27							
36	44	54	32	J8	P12	Q	J
					AN02		
					SOT1_1 (SDA1_1)		
					IC00_2		
					SEG26		

MB9AA30N Series

Pin No					Pin name	I/O circuit type	Pin state type
LQFP-64 QFN-64	LQFP-80	LQFP-100	QFP-100	BGA-112			
-	-	-	-	K10	VSS	-	
-	-	-	-	J9	VSS	-	
37	45	55	33	H10	P13	Q	J
					AN03		
					SCK1_1 (SCL1_1)		
					IC01_2		
					RTCCO_1		
					SUBOUT_1		
38	46	56	34	H9	P14	Q	K
					AN04		
					INT03_1		
					IC02_2		
					SEG24		
-					SIN0_1		
39	47	57	35	H7	P15	Q	J
					AN05		
					IC03_2		
					SEG23		
-					SOT0_1		
-	48	58	36	G10	P16	Q	J
					AN06		
					SCK0_1 (SCL0_1)		
					SEG22		
40	49	59	37	G9	P17	Q	K
					AN07		
					SIN2_2		
					INT04_1		
					SEG21		
41	50	60	38	H11	AVCC	-	
42	51	61	39	F11	AVRH	-	
43	52	62	40	G11	AVSS	-	
44	53	63	41	G8	P18	Q	J
					AN08		
					SOT2_2 (SDA2_2)		
					SEG20		
45	54	64	42	F10	P19	Q	J
					AN09		
					SCK2_2 (SCL2_2)		
					SEG19		
-	-	-	-	H8	VSS	-	

MB9AA30N Series

Pin No					Pin name	I/O circuit type	Pin state type
LQFP-64 QFN-64	LQFP-80	LQFP-100	QFP-100	BGA-112			
-	55	65	43	F9	P1A	Q	K
					AN10		
					SIN4_1		
					INT05_1		
					IC00_1		
SEG18							
-	56	66	44	E11	P1B	Q	J
					AN11		
					SOT4_1 (SDA4_1)		
					IC01_1		
SEG17							
-	-	67	45	E10	P1C	Q	J
					AN12		
					SCK4_1 (SCL4_1)		
					IC02_1		
SEG16							
-	-	68	46	F8	P1D	Q	J
					AN13		
					CTS4_1		
					IC03_1		
SEG15							
-	-	69	47	E9	P1E	Q	J
					AN14		
					RTS4_1		
					DTTIOX_1		
SEG14							
-	-	70	48	D11	P1F	F	X
					AN15		
					ADTG_5		
					FRCK0_1		
-	-	-	-	B10	VSS	-	
-	-	-	-	C9	VSS	-	
46	57	71	49	D10	P23	J	U
					SCK0_0 (SCL0_0)		
					TIOA7_1		
					SEG13		
-	-				RTO00_1		
47	58	72	50	E8	P22	J	U
					SOT0_0 (SDA0_0)		
					TIOB7_1		
					SEG12		

MB9AA30N Series

Pin No					Pin name	I/O circuit type	Pin state type
LQFP-64 QFN-64	LQFP-80	LQFP-100	QFP-100	BGA-112			
48	59	73	51	C11	P21	J	T
					SIN0_0		
					INT06_1		
					WKUP2		
-	60	74	52	C10	P20	J	S
					INT05_0		
					CROUT_0		
					SEG10		
-	-	75	53	A11	VSS	-	-
-	-	76	54	A10	VCC	-	-
49	61	77	55	A9	P00	E	E
					TRSTX		
50	62	78	56	B9	P01	E	E
					TCK		
					SWCLK		
51	63	79	57	B11	P02	E	E
					TDI		
52	64	80	58	A8	P03	E	E
					TMS		
					SWDIO		
53	65	81	59	B8	P04	E	E
					TDO		
					SWO		
-	-	82	60	C8	P05	J	S
					TIOA5_2		
					SIN4_2		
					INT00_1		
-	-	-	-	D8	VSS	-	-
-	-	83	61	D9	P06	J	S
					TIOB5_2		
					SOT4_2 (SDA4_2)		
					INT01_1		
-	66	84	62	A7	P07	J	U
					ADTG_0		
	SEG07						
	-				SCK4_2 (SCL4_2)		
-	-	85	63	B7	P08	J	U
					TIOA0_2		
					CTS4_2		
					SEG06		

MB9AA30N Series

Pin No					Pin name	I/O circuit type	Pin state type
LQFP-64 QFN-64	LQFP-80	LQFP-100	QFP-100	BGA-112			
-	-	86	64	C7	P09	J	U
					TIOB0_2		
					RTS4_2		
					SEG05		
54	67	87	65	D7	P0A	G	F
					SIN4_0		
					INT00_2		
55	68	88	66	A6	P0B	G	H
					SOT4_0 (SDA4_0)		
					TIOB6_1		
56	69	89	67	B6	P0C	G	H
					SCK4_0 (SCL4_0)		
					TIOA6_1		
-	-	-	-	D4	VSS	-	-
-	-	-	-	C3	VSS	-	-
-	70	90	68	C6	P0D	J	U
					RTS4_0		
					TIOA3_2		
					SEG04		
-	71	91	69	A5	P0E	J	U
					CTS4_0		
					TIOB3_2		
					SEG03		
57	72	92	70	B5	P0F	E	I
					NMIX		
					CROUT_1		
					RTCCO_0		
					SUBOUT_0		
					WKUP0		
-	73	93	71	D6	P63	J	S
					INT03_0		
					SEG02		
58	74	94	72	C5	P62	J	U
					SCK5_0 (SCL5_0)		
					ADTG_3		
					SEG01		
59	75	95	73	B4	P61	J	U
					SOT5_0 (SDA5_0)		
					TIOB2_2		
					DTTI0X_2		
					SEG00		

MB9AA30N Series

Pin No					Pin name	I/O circuit type	Pin state type
LQFP-64 QFN-64	LQFP-80	LQFP-100	QFP-100	BGA-112			
60	76	96	74	C4	P60	G	R
					SIN5_0		
					TIOA2_2		
					INT15_1		
					WKUP3		
CEC1							
61	77	97	75	A4	P80	G	H
					SIN7_2		
62	78	98	76	A3	P81	G	H
					SOT7_2		
63	79	99	77	A2	P82	G	H
					SCK7_2		
64	80	100	78	A1	VSS	-	-

MB9AA30N Series

- List of pin functions

The number after the underscore ("_") in pin names such as XXX_1 and XXX_2 indicates the relocated port number. For these pins, there are multiple pins that provide the same function for the same channel. Use the extended port function register (EPFR) to select the pin.

Pin function	Pin name	Function description	Pin No				
			LQFP-64, QFN-64	LQFP-80	LQFP-100	QFP-100	BGA-112
ADC	ADTG_0	A/D converter external trigger input pin	-	66	84	62	A7
	ADTG_1		-	7	7	85	D3
	ADTG_2		9	13	18	96	F4
	ADTG_3		58	74	94	72	C5
	ADTG_4		-	-	-	-	-
	ADTG_5		-	-	70	48	D11
	ADTG_6		8	12	12	90	E4
	ADTG_7		-	-	30	8	J5
	ADTG_8		-	-	-	-	-
	AN00	A/D converter analog input pin. ANxx describes ADC ch.xx.	34	42	52	30	J11
	AN01		35	43	53	31	J10
	AN02		36	44	54	32	J8
	AN03		37	45	55	33	H10
	AN04		38	46	56	34	H9
	AN05		39	47	57	35	H7
	AN06		-	48	58	36	G10
	AN07		40	49	59	37	G9
	AN08		44	53	63	41	G8
	AN09		45	54	64	42	F10
	AN10		-	55	65	43	F9
	AN11		-	56	66	44	E11
	AN12		-	-	67	45	E10
	AN13		-	-	68	46	F8
	AN14		-	-	69	47	E9
	AN15		-	-	70	48	D11

MB9AA30N Series

Pin function	Pin name	Function description	Pin No				
			LQFP-64, QFN-64	LQFP-80	LQFP-100	QFP-100	BGA-112
Base Timer 0	TIOA0_0	Base timer ch.0 TIOA pin	-	-	27	5	J4
	TIOA0_1		10	14	19	97	G3
	TIOA0_2		-	-	85	63	B7
	TIOB0_0	Base timer ch.0 TIOB pin	22	30	40	18	J6
	TIOB0_1		5	9	9	87	E1
	TIOB0_2		-	-	86	64	C7
Base Timer 1	TIOA1_0	Base timer ch.1 TIOA pin	-	-	28	6	L5
	TIOA1_1		11	15	20	98	H1
	TIOA1_2		-	5	5	83	D1
	TIOB1_0	Base timer ch.1 TIOB pin	23	31	41	19	L7
	TIOB1_1		6	10	10	88	E2
	TIOB1_2		-	6	6	84	D2
Base Timer 2	TIOA2_0	Base timer ch.2 TIOA pin	-	-	29	7	K5
	TIOA2_1		12	16	21	99	H2
	TIOA2_2		60	76	96	74	C4
	TIOB2_0	Base timer ch.2 TIOB pin	24	32	42	20	K7
	TIOB2_1		7	11	11	89	E3
	TIOB2_2		59	75	95	73	B4
Base Timer 3	TIOA3_0	Base timer ch.3 TIOA pin	-	-	30	8	J5
	TIOA3_1		13	17	22	100	G4
	TIOA3_2		-	70	90	68	C6
	TIOB3_0	Base timer ch.3 TIOB pin	25	33	43	21	H6
	TIOB3_1		8	12	12	90	E4
	TIOB3_2		-	71	91	69	A5
Base Timer 4	TIOA4_0	Base timer ch.4 TIOA pin	-	21	31	9	H5
	TIOA4_1		14	18	23	1	H3
	TIOA4_2		-	-	-	-	-
	TIOB4_0	Base timer ch.4 TIOB pin	26	34	44	22	J7
	TIOB4_1		-	-	13	91	F1
	TIOB4_2		-	-	-	-	-
Base Timer 5	TIOA5_0	Base timer ch.5 TIOA pin	-	22	32	10	L6
	TIOA5_1		15	19	24	2	J2
	TIOA5_2		-	-	82	60	C8
	TIOB5_0	Base timer ch.5 TIOB pin	27	35	45	23	K8
	TIOB5_1		-	-	14	92	F2
	TIOB5_2		-	-	83	61	D9
Base Timer 6	TIOA6_1	Base timer ch.6 TIOA pin	56	69	89	67	B6
	TIOB6_1	Base timer ch.6 TIOB pin	55	68	88	66	A6
Base Timer 7	TIOA7_0	Base timer ch.7 TIOA pin	-	-	-	-	-
	TIOA7_1		46	57	71	49	D10
	TIOA7_2		-	-	-	-	-
	TIOB7_0	Base timer ch.7 TIOB pin	-	-	-	-	-
	TIOB7_1		47	58	72	50	E8
	TIOB7_2		-	-	-	-	-

MB9AA30N Series

Pin function	Pin name	Function description	Pin No				
			LQFP-64, QFN-64	LQFP-80	LQFP-100	QFP-100	BGA-112
Debugger	SWCLK	Serial wire debug interface clock input pin	50	62	78	56	B9
	SWDIO	Serial wire debug interface data input / output pin	52	64	80	58	A8
	SWO	Serial wire viewer output pin	53	65	81	59	B8
	TRSTX	J-TAG reset input pin	49	61	77	55	A9
	TCK	J-TAG test clock input pin	50	62	78	56	B9
	TDI	J-TAG test data input pin	51	63	79	57	B11
	TMS	J-TAG test mode state input/output pin	52	64	80	58	A8
	TDO	J-TAG debug data output pin	53	65	81	59	B8
External Interrupt	INT00_0	External interrupt request 00 input pin	2	2	2	80	C1
	INT00_1		-	-	82	60	C8
	INT00_2		54	67	87	65	D7
	INT01_0	External interrupt request 01 input pin	3	3	3	81	C2
	INT01_1		-	-	83	61	D9
	INT02_0	External interrupt request 02 input pin	4	4	4	82	B3
	INT02_1		35	43	53	31	J10
	INT03_0	External interrupt request 03 input pin	-	73	93	71	D6
	INT03_1		38	46	56	34	H9
	INT03_2		5	9	9	87	E1
	INT04_0	External interrupt request 04 input pin	8	12	12	90	E4
	INT04_1		40	49	59	37	G9
	INT04_2		6	10	10	88	E2
	INT05_0	External interrupt request 05 input pin	-	60	74	52	C10
	INT05_1		-	55	65	43	F9
	INT05_2		7	11	11	89	E3
	INT06_1	External interrupt request 06 input pin	48	59	73	51	C11
	INT06_2		27	35	45	23	K8
	INT07_2	External interrupt request 07 input pin	-	5	5	83	D1
	INT08_1	External interrupt request 08 input pin	-	-	14	92	F2
	INT08_2		-	8	8	86	D5
	INT09_1	External interrupt request 09 input pin	-	-	15	93	F3
	INT10_1	External interrupt request 10 input pin	-	-	16	94	G1
	INT11_1	External interrupt request 11 input pin	-	-	17	95	G2
	INT12_1	External interrupt request 12 input pin	-	-	27	5	J4
	INT13_1	External interrupt request 13 input pin	-	-	28	6	L5
	INT14_1	External interrupt request 14 input pin	-	29	39	17	K6
	INT15_1	External interrupt request 15 input pin	60	76	96	74	C4
NMIX	Non-Maskable Interrupt input pin	57	72	92	70	B5	

MB9AA30N Series

Pin function	Pin name	Function description	Pin No				
			LQFP-64, QFN-64	LQFP-80	LQFP-100	QFP-100	BGA-112
GPIO	P00	General-purpose I/O port 0	49	61	77	55	A9
	P01		50	62	78	56	B9
	P02		51	63	79	57	B11
	P03		52	64	80	58	A8
	P04		53	65	81	59	B8
	P05		-	82	60	C8	
	P06		-	83	61	D9	
	P07		-	84	62	A7	
	P08		-	85	63	B7	
	P09		-	86	64	C7	
	P0A		54	87	65	D7	
	P0B		55	88	66	A6	
	P0C		56	89	67	B6	
	P0D		-	90	68	C6	
	P0E		-	91	69	A5	
	P0F		57	92	70	B5	
	P10		General-purpose I/O port 1	34	42	52	30
	P11	35		43	53	31	J10
	P12	36		44	54	32	J8
	P13	37		45	55	33	H10
	P14	38		46	56	34	H9
	P15	39		47	57	35	H7
	P16	-		48	58	36	G10
	P17	40		49	59	37	G9
	P18	44		53	63	41	G8
	P19	45		54	64	42	F10
	P1A	-		55	65	43	F9
	P1B	-		56	66	44	E11
	P1C	-		67	45	E10	
	P1D	-	68	46	F8		
	P1E	-	69	47	E9		
	P1F	-	70	48	D11		
	P20	General-purpose I/O port 2	-	60	74	52	C10
P21	48		59	73	51	C11	
P22	47		58	72	50	E8	
P23	46		57	71	49	D10	

MB9AA30N Series

Pin function	Pin name	Function description	Pin No					
			LQFP-64, QFN-64	LQFP-80	LQFP-100	QFP-100	BGA-112	
GPIO	P30	General-purpose I/O port 3	5	9	9	87	E1	
	P31		6	10	10	88	E2	
	P32		7	11	11	89	E3	
	P33		8	12	12	90	E4	
	P34		-	-	13	91	F1	
	P35		-	-	14	92	F2	
	P36		-	-	15	93	F3	
	P37		-	-	16	94	G1	
	P38		-	-	17	95	G2	
	P39		9	13	18	96	F4	
	P3A		10	14	19	97	G3	
	P3B		11	15	20	98	H1	
	P3C		12	16	21	99	H2	
	P3D		13	17	22	100	G4	
	P3E		14	18	23	1	H3	
	P3F	15	19	24	2	J2		
	P40	-	General-purpose I/O port 4	-	-	27	5	J4
	P41	-		-	28	6	L5	
	P42	-		-	29	7	K5	
	P43	-		-	30	8	J5	
	P44	-		21	31	9	H5	
	P45	-		22	32	10	L6	
	P46	19		26	36	14	L3	
	P47	20		27	37	15	K3	
	P48	-		29	39	17	K6	
	P49	22		30	40	18	J6	
	P4A	23		31	41	19	L7	
	P4B	24	32	42	20	K7		
	P4C	25	33	43	21	H6		
	P4D	26	34	44	22	J7		
	P4E	27	35	45	23	K8		
P50	2	General-purpose I/O port 5	2	2	2	80	C1	
P51	3		3	3	81	C2		
P52	4		4	4	82	B3		
P53	-		5	5	83	D1		
P54	-		6	6	84	D2		
P55	-	7	7	85	D3			
P56	-	8	8	86	D5			
P60	60	General-purpose I/O port 6	76	96	74	C4		
P61	59		75	95	73	B4		
P62	58		74	94	72	C5		
P63	-		73	93	71	D6		
P80	61	General-purpose I/O port 8	77	97	75	A4		
P81	62		78	98	76	A3		
P82	63		79	99	77	A2		
PE0	28	General-purpose I/O port E	36	46	24	K9		
PE2	30		38	48	26	L9		
PE3	31		39	49	27	L10		

MB9AA30N Series

Pin function	Pin name	Function description	Pin No				
			LQFP-64, QFN-64	LQFP-80	LQFP-100	QFP-100	BGA-112
Multi-function Serial 0	SIN0_0	Multi-function serial interface ch.0 input pin	48	59	73	51	C11
	SIN0_1		-	46	56	34	H9
	SOT0_0 (SDA0_0)	Multi-function serial interface ch.0 output pin. This pin operates as SOT0 when it is used in a UART/CSIO (operation modes 0 to 2) and as SDA0 when it is used in an I ² C (operation mode 4).	47	58	72	50	E8
	SOT0_1 (SDA0_1)		-	47	57	35	H7
	SCK0_0 (SCL0_0)	Multi-function serial interface ch.0 clock I/O pin. This pin operates as SCK0 when it is used in a UART/CSIO (operation modes 0 to 2) and as SCL0 when it is used in an I ² C (operation mode 4).	46	57	71	49	D10
	SCK0_1 (SCL0_1)		-	48	58	36	G10
Multi-function Serial 1	SIN1_1	Multi-function serial interface ch.1 input pin	35	43	53	31	J10
	SOT1_1 (SDA1_1)	Multi-function serial interface ch.1 output pin. This pin operates as SOT1 when it is used in a UART/CSIO (operation modes 0 to 2) and as SDA1 when it is used in an I ² C (operation mode 4).	36	44	54	32	J8
	SCK1_1 (SCL1_1)	Multi-function serial interface ch.1 clock I/O pin. This pin operates as SCK1 when it is used in a UART/CSIO (operation modes 0 to 2) and as SCL1 when it is used in an I ² C (operation mode 4).	37	45	55	33	H10
Multi-function Serial 2	SIN2_2	Multi-function serial interface ch.2 input pin	40	49	59	37	G9
	SOT2_2 (SDA2_2)	Multi-function serial interface ch.2 output pin. This pin operates as SOT2 when it is used in a UART/CSIO (operation modes 0 to 2) and as SDA2 when it is used in an I ² C (operation mode 4).	44	53	63	41	G8
	SCK2_2 (SCL2_2)	Multi-function serial interface ch.2 clock I/O pin. This pin operates as SCK2 when it is used in a UART/CSIO (operation modes 0 to 2) and as SCL2 when it is used in an I ² C (operation mode 4).	45	54	64	42	F10

MB9AA30N Series

Pin function	Pin name	Function description	Pin No				
			LQFP-64, QFN-64	LQFP-80	LQFP-100	QFP-100	BGA-112
Multi-function Serial 3	SIN3_1	Multi-function serial interface ch.3 input pin	2	2	2	80	C1
	SIN3_2		-	29	39	17	K6
	SOT3_1 (SDA3_1)	Multi-function serial interface ch.3 output pin. This pin operates as SOT3 when it is used in a UART/CSIO (operation modes 0 to 2) and as SDA3 when it is used in an I ² C (operation mode 4).	3	3	3	81	C2
	SOT3_2 (SDA3_2)		-	30	40	18	J6
	SCK3_1 (SCL3_1)	Multi-function serial interface ch.3 clock I/O pin. This pin operates as SCK3 when it is used in a UART/CSIO (operation modes 0 to 2) and as SCL3 when it is used in an I ² C (operation mode 4).	4	4	4	82	B3
	SCK3_2 (SCL3_2)		-	31	41	19	L7
Multi-function Serial 4	SIN4_0	Multi-function serial interface ch.4 input pin	54	67	87	65	D7
	SIN4_1		-	55	65	43	F9
	SIN4_2		-	-	82	60	C8
	SOT4_0 (SDA4_0)	Multi-function serial interface ch.4 output pin. This pin operates as SOT4 when it is used in a UART/CSIO (operation modes 0 to 2) and as SDA4 when it is used in an I ² C (operation mode 4).	55	68	88	66	A6
	SOT4_1 (SDA4_1)		-	56	66	44	E11
	SOT4_2 (SDA4_2)		-	-	83	61	D9
	SCK4_0 (SCL4_0)	Multi-function serial interface ch.4 clock I/O pin. This pin operates as SCK4 when it is used in a UART/CSIO (operation modes 0 to 2) and as SCL4 when it is used in an I ² C (operation mode 4).	56	69	89	67	B6
	SCK4_1 (SCL4_1)		-	-	67	45	E10
	SCK4_2 (SCL4_2)		-	-	84	62	A7
	RTS4_0	Multi-function serial interface ch.4 RTS output pin	-	70	90	68	C6
	RTS4_1		-	-	69	47	E9
	RTS4_2		-	-	86	64	C7
	CTS4_0	Multi-function serial interface ch.4 CTS input pin	-	71	91	69	A5
	CTS4_1		-	-	68	46	F8
	CTS4_2		-	-	85	63	B7

MB9AA30N Series

Pin function	Pin name	Function description	Pin No				
			LQFP-64, QFN-64	LQFP-80	LQFP-100	QFP-100	BGA-112
Multi-function Serial 5	SIN5_0	Multi-function serial interface ch.5 input pin	60	76	96	74	C4
	SIN5_2		-	-	15	93	F3
	SOT5_0 (SDA5_0)	Multi-function serial interface ch.5 output pin. This pin operates as SOT5 when it is used in a UART/CSIO (operation modes 0 to 2) and as SDA5 when it is used in an I ² C (operation mode 4).	59	75	95	73	B4
	SOT5_2 (SDA5_2)		-	-	16	94	G1
	SCK5_0 (SCL5_0)	Multi-function serial interface ch.5 clock I/O pin. This pin operates as SCK5 when it is used in a UART/CSIO (operation modes 0 to 2) and as SCL5 when it is used in an I ² C (operation mode 4).	58	74	94	72	C5
	SCK5_2 (SCL5_2)		-	-	17	95	G2
Multi-function Serial 6	SIN6_0	Multi-function serial interface ch.6 input pin	-	5	5	83	D1
	SIN6_1		8	12	12	90	E4
	SOT6_0 (SDA6_0)	Multi-function serial interface ch.6 output pin. This pin operates as SOT6 when it is used in a UART/CSIO (operation modes 0 to 2) and as SDA6 when it is used in an I ² C (operation mode 4).	-	6	6	84	D2
	SOT6_1 (SDA6_1)		7	11	11	89	E3
	SCK6_0 (SCL6_0)	Multi-function serial interface ch.6 clock I/O pin. This pin operates as SCK6 when it is used in a UART/CSIO (operation modes 0 to 2) and as SCL6 when it is used in an I ² C (operation mode 4).	-	7	7	85	D3
	SCK6_1 (SCL6_1)		6	10	10	88	E2
Multi-function Serial 7	SIN7_1	Multi-function serial interface ch.7 input pin	27	35	45	23	K8
	SIN7_2		61	77	97	75	A4
	SOT7_1 (SDA7_1)	Multi-function serial interface ch.7 output pin. This pin operates as SOT7 when it is used in a UART/CSIO (operation modes 0 to 2) and as SDA7 when it is used in an I ² C (operation mode 4).	26	34	44	22	J7
	SOT7_2 (SDA7_2)		62	78	98	76	A3
	SCK7_1 (SCL7_1)	Multi-function serial interface ch.7 clock I/O pin. This pin operates as SCK7 when it is used in a UART/CSIO (operation modes 0 to 2) and as SCL7 when it is used in an I ² C (operation mode 4).	25	33	43	21	H6
	SCK7_2 (SCL7_2)		63	79	99	77	A2

MB9AA30N Series

Pin function	Pin name	Function description	Pin No					
			LQFP-64, QFN-64	LQFP-80	LQFP-100	QFP-100	BGA-112	
Multi-function Timer 0	DTTIOX_0	Input signal of waveform generator to control outputs RTO00 to RTO05 of Multi-function timer 0	9	13	18	96	F4	
	DTTIOX_1		-	-	69	47	E9	
	DTTIOX_2		59	75	95	73	B4	
	FRCK0_0	16-bit free-run timer ch.0 external clock input pin	-	-	13	91	F1	
	FRCK0_1		-	-	70	48	D11	
	FRCK0_2		35	43	53	31	J10	
	IC00_0	16-bit input capture input pin of Multi-function timer 0. ICxx describes a channel number.	-	-	17	95	G2	
	IC00_1		-	55	65	43	F9	
	IC00_2		36	44	54	32	J8	
	IC01_0		-	-	16	94	G1	
	IC01_1		-	56	66	44	E11	
	IC01_2		37	45	55	33	H10	
	IC02_0		-	-	15	93	F3	
	IC02_1		-	-	67	45	E10	
	IC02_2		38	46	56	34	H9	
	IC03_0		-	-	14	92	F2	
	IC03_1		-	-	68	46	F8	
	IC03_2		39	47	57	35	H7	
	RTO00_0 (PPG00_0)		Waveform generator output pin of Multi-function timer 0.	10	14	19	97	G3
	RTO00_1 (PPG00_1)		This pin operates as PPG00 when it is used in PPG0 output mode.	-	-	71	49	D10
RTO01_0 (PPG00_0)	Waveform generator output pin of Multi-function timer 0. This pin operates as PPG00 when it is used in PPG0 output mode.	11	15	20	98	H1		
RTO02_0 (PPG02_0)	Waveform generator output pin of Multi-function timer 0. This pin operates as PPG02 when it is used in PPG0 output mode.	12	16	21	99	H2		
RTO03_0 (PPG02_0)	Waveform generator output pin of Multi-function timer 0. This pin operates as PPG02 when it is used in PPG0 output mode.	13	17	22	100	G4		
RTO04_0 (PPG04_0)	Waveform generator output pin of Multi-function timer 0. This pin operates as PPG04 when it is used in PPG0 output mode.	14	18	23	1	H3		
RTO05_0 (PPG04_0)	Waveform generator output pin of Multi-function timer 0. This pin operates as PPG04 when it is used in PPG0 output mode.	15	19	24	2	J2		
IGTRG	PPG IGBT mode external trigger input pin	24	32	42	20	K7		

MB9AA30N Series

Pin function	Pin name	Function description	Pin No				
			LQFP-64, QFN-64	LQFP-80	LQFP-100	QFP-100	BGA-112
LCD Controller	VV0	LCD controller power supply I/O pin	-	6	6	84	D2
	VV1		-	5	5	83	D1
	VV2		-	4	4	82	B3
	VV3		-	3	3	81	C2
	VV4		2	2	2	80	C1
	COM0	LCD controller common output pin	12	16	21	99	H2
	COM1		11	15	20	98	H1
	COM2		10	14	19	97	G3
	COM3		9	13	18	96	F4
	COM4		8	12	12	90	E4
	COM5		7	11	11	89	E3
	COM6		6	10	10	88	E2
	COM7	5	9	9	87	E1	
	SEG00	LCD controller segment output pin	59	75	95	73	B4
	SEG01		58	74	94	72	C5
	SEG02		-	73	93	71	D6
	SEG03		-	71	91	69	A5
	SEG04		-	70	90	68	C6
	SEG05		-	-	86	64	C7
	SEG06		-	-	85	63	B7
	SEG07		-	66	84	62	A7
	SEG08		-	-	83	61	D9
	SEG09		-	-	82	60	C8
	SEG10		-	60	74	52	C10
	SEG11		48	59	73	51	C11
	SEG12		47	58	72	50	E8
	SEG13		46	57	71	49	D10
	SEG14		-	-	69	47	E9
	SEG15		-	-	68	46	F8
	SEG16		-	-	67	45	E10
	SEG17		-	56	66	44	E11
	SEG18		-	55	65	43	F9
	SEG19		45	54	64	42	F10
	SEG20		44	53	63	41	G8
	SEG21		40	49	59	37	G9
SEG22	-		48	58	36	G10	
SEG23	39		47	57	35	H7	
SEG24	38		46	56	34	H9	
SEG25	37		45	55	33	H10	
SEG26	36		44	54	32	J8	
SEG27	35		43	53	31	J10	
SEG28	34		42	52	30	J11	
SEG29	24		32	42	20	K7	
SEG30	23		31	41	19	L7	
SEG31	22		30	40	18	J6	
SEG32	-		29	39	17	K6	
SEG33	-		22	32	10	L6	
SEG34	-		21	31	9	H5	
SEG35	15	19	24	2	J2		

MB9AA30N Series

Pin function	Pin name	Function description	Pin No				
			LQFP-64, QFN-64	LQFP-80	LQFP-100	QFP-100	BGA-112
LCD Controller	SEG36	LCD controller segment output pin	14	18	23	1	H3
	SEG37		13	17	22	100	G4
	SEG38		-	8	8	86	D5
	SEG39		-	7	7	85	D3
	SEG40		8	12	12	90	E4
	SEG41		7	11	11	89	E3
	SEG42		6	10	10	88	E2
	SEG43		5	9	9	87	E1
Real-time clock	RTCCO_0	Pulse output pin of Real-time clock	57	72	92	70	B5
	RTCCO_1		37	45	55	33	H10
	RTCCO_2		10	14	19	97	G3
	SUBOUT_0	Sub clock output pin	57	72	92	70	B5
	SUBOUT_1		37	45	55	33	H10
	SUBOUT_2		10	14	19	97	G3
Low-Power Consumption Mode	WKUP0	Deep standby mode return signal input pin 0	57	72	92	70	B5
	WKUP1	Deep standby mode return signal input pin 1	35	43	53	31	J10
	WKUP2	Deep standby mode return signal input pin 2	48	59	73	51	C11
	WKUP3	Deep standby mode return signal input pin 3	60	76	96	74	C4
DAC	DA0	D/A converter ch.0 analog output pin	26	34	44	22	J7
	DA1	D/A converter ch.1 analog output pin	27	35	45	23	K8
HDMI-CEC/Remote Control Reception	CEC0	HDMI-CEC/Remote Control Reception ch.0 input/output pin	25	33	43	21	H6
	CEC1	HDMI-CEC/Remote Control Reception ch.1 input/output pin	60	76	96	74	C4

MB9AA30N Series

Pin function	Pin name	Function description	Pin No				
			LQFP-64, QFN-64	LQFP-80	LQFP-100	QFP-100	BGA-112
RESET	INITX	External Reset Input Pin. A reset is valid when INITX = "L".	21	28	38	16	K4
Mode	MD0	Mode 0 pin. During normal operation, MD0 = "L" must be input. During serial programming to Flash memory, MD0 = "H" must be input.	29	37	47	25	L8
	MD1	Mode 1 pin. During normal operation, input is not needed. During serial programming to Flash memory, MD1 = "L" must be input.	28	36	46	24	K9
POWER	VCC	Power supply pin	1	1	1	79	B1
	VCC		-	-	26	4	J1
	VCC		18	25	35	13	K1
	VCC		33	41	51	29	K11
	VCC		-	-	76	54	A10
GND	VSS	GND pin	-	-	-	-	B2
	VSS		16	20	25	3	L1
	VSS		-	-	-	-	K2
	VSS		-	-	-	-	J3
	VSS		-	-	-	-	H4
	VSS		-	24	34	12	L4
	VSS		32	40	50	28	L11
	VSS		-	-	-	-	K10
	VSS		-	-	-	-	J9
	VSS		-	-	-	-	H8
	VSS		-	-	-	-	B10
	VSS		-	-	-	-	C9
	VSS		-	-	75	53	A11
	VSS		-	-	-	-	D8
	VSS		-	-	-	-	D4
	VSS		-	-	-	-	C3
	VSS		64	80	100	78	A1
CLOCK	X0	Main clock (oscillation) input pin	30	38	48	26	L9
	X0A	Sub clock (oscillation) input pin	19	26	36	14	L3
	X1	Main clock (oscillation) I/O pin	31	39	49	27	L10
	X1A	Sub clock (oscillation) I/O pin	20	27	37	15	K3
	CROUT_0	Built-in high-speed CR-osc clock output port	-	60	74	52	C10
	CROUT_1		57	72	92	70	B5
Analog POWER	AVCC	A/D converter and D/A converter analog power supply pin	41	50	60	38	H11
	AVRH	A/D converter analog reference voltage input pin	42	51	61	39	F11
Analog GND	AVSS	A/D converter and D/A converter GND pin	43	52	62	40	G11
C pin	C	Power supply stabilization capacity pin	17	23	33	11	L2

MB9AA30N Series

■ I/O CIRCUIT TYPE

Type	Circuit	Remarks
A		<p>It is possible to select the main oscillation / GPIO function.</p> <p>When the main oscillation is selected.</p> <ul style="list-style-type: none"> • Oscillation feedback resistor : Approximately 1MΩ • With standby mode control <p>When the GPIO is selected.</p> <ul style="list-style-type: none"> • CMOS level output. • CMOS level hysteresis input • With pull-up resistor control • With standby mode control • Pull-up resistor : Approximately 50kΩ • $I_{OH} = -4\text{mA}$, $I_{OL} = 4\text{mA}$
B		<ul style="list-style-type: none"> • CMOS level hysteresis input • Pull-up resistor : Approximately 50kΩ

MB9AA30N Series

Type	Circuit	Remarks
C	<p>The diagram shows a square wave source connected to a node. This node is connected to a pull-up resistor and the gate of an N-channel MOSFET. The MOSFET's drain is connected to the same node, and its source is grounded. The node is also connected to the input of a CMOS inverter with hysteresis, which outputs a digital signal.</p>	<ul style="list-style-type: none"> • Open drain output • CMOS level hysteresis input
D	<p>The diagram shows two oscillators, X1A and X0A, connected to a common bus through pull-up resistors (R). The bus is connected to several digital functions: <ul style="list-style-type: none"> Two P-channel MOSFETs and one N-channel MOSFET for digital outputs. A pull-up resistor control signal. A digital input with hysteresis. A standby mode control signal. A clock input with hysteresis. Another digital input with hysteresis. Another standby mode control signal. Another digital input with hysteresis. Another standby mode control signal. Two more P-channel MOSFETs and one N-channel MOSFET for digital outputs. A pull-up resistor control signal. </p>	<p>It is possible to select the sub oscillation / GPIO function</p> <p>When the sub oscillation is selected.</p> <ul style="list-style-type: none"> • Oscillation feedback resistor : Approximately 5MΩ • With standby mode control <p>When the GPIO is selected.</p> <ul style="list-style-type: none"> • CMOS level output. • CMOS level hysteresis input • With pull-up resistor control • With standby mode control • Pull-up resistor : Approximately 50kΩ • $I_{OH} = -4\text{mA}$, $I_{OL} = 4\text{mA}$

MB9AA30N Series

Type	Circuit	Remarks
E	<p>The circuit diagram for Type E shows a CMOS output stage. It consists of a P-channel MOSFET (P-ch) and an N-channel MOSFET (N-ch). The gates of both MOSFETs are connected to a common node. This node is connected to a pull-up resistor R and a digital input signal. The P-ch MOSFET's source is connected to a supply rail, and its drain is connected to the output node. The N-ch MOSFET's source is connected to ground, and its drain is also connected to the output node. A standby mode control signal is connected to the gates of both MOSFETs through an inverter. The output node is labeled 'Digital output'.</p>	<ul style="list-style-type: none"> • CMOS level output • CMOS level hysteresis input • With pull-up resistor control • With standby mode control • Pull-up resistor : Approximately 50kΩ • $I_{OH} = -4\text{mA}$, $I_{OL} = 4\text{mA}$
F	<p>The circuit diagram for Type F shows a CMOS output stage similar to Type E, but with an additional analog input. It consists of a P-channel MOSFET (P-ch) and an N-channel MOSFET (N-ch). The gates of both MOSFETs are connected to a common node. This node is connected to a pull-up resistor R and a digital input signal. The P-ch MOSFET's source is connected to a supply rail, and its drain is connected to the output node. The N-ch MOSFET's source is connected to ground, and its drain is also connected to the output node. A standby mode control signal is connected to the gates of both MOSFETs through an inverter. The output node is labeled 'Digital output'. An analog input signal is connected to the gates of both MOSFETs through an inverter and a buffer. The input control signal is connected to the gates of both MOSFETs through an inverter.</p>	<ul style="list-style-type: none"> • CMOS level output • CMOS level hysteresis input • With input control • Analog input • With pull-up resistor control • With standby mode control • Pull-up resistor : Approximately 50kΩ • $I_{OH} = -4\text{mA}$, $I_{OL} = 4\text{mA}$

MB9AA30N Series

Type	Circuit	Remarks
G		<ul style="list-style-type: none"> • CMOS level output • CMOS level hysteresis input • With standby mode control • 5 V tolerant input • $I_{OH} = -4\text{mA}$, $I_{OL} = 4\text{mA}$ • Available to control PZR registers. P0B, P0C, P4C, P60, P81, P82 only.
H		<p>CMOS level hysteresis input</p>
J		<ul style="list-style-type: none"> • CMOS level output • CMOS level hysteresis input • With input control • LCD segment output • With pull-up resistor control • With standby mode control • Pull-up resistor : Approximately $50\text{k}\Omega$ • $I_{OH} = -4\text{mA}$, $I_{OL} = 4\text{mA}$

MB9AA30N Series

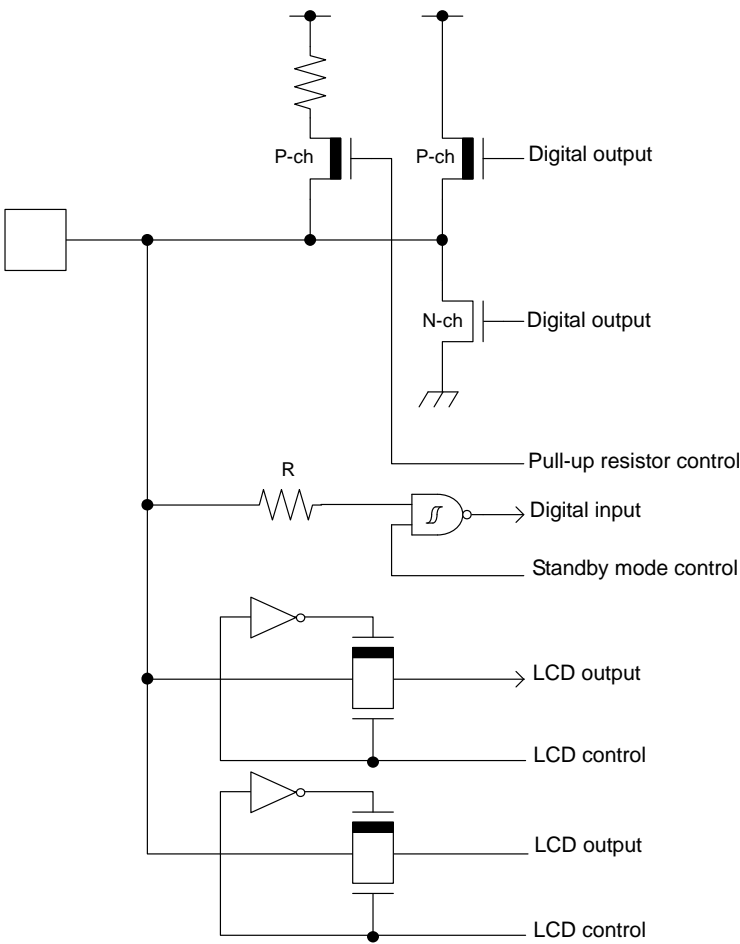
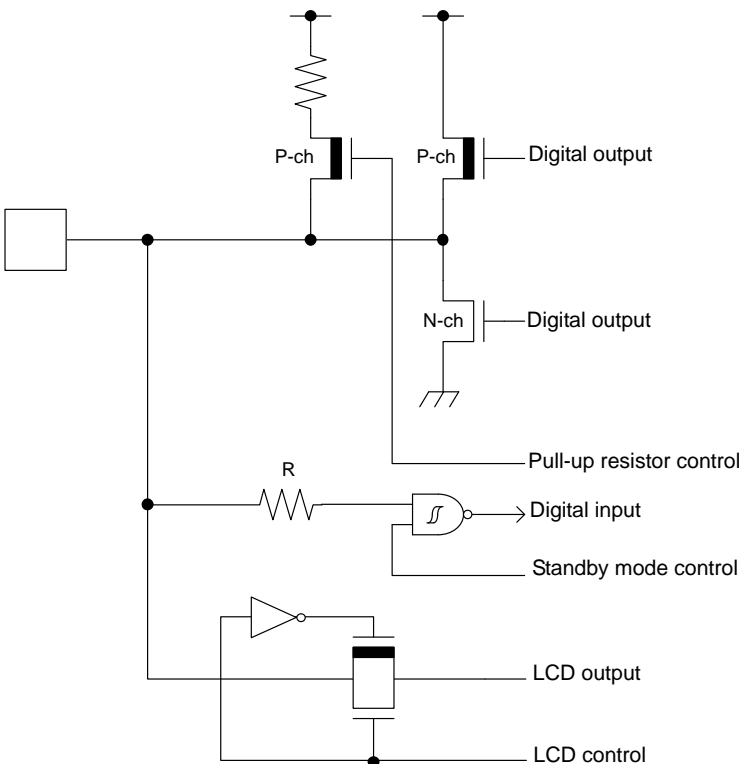
Type	Circuit	Remarks
K	 <p>The circuit diagram for Type K shows a CMOS output stage. It includes a pull-up resistor connected to a supply rail. The output stage consists of a P-channel MOSFET (P-ch) and an N-channel MOSFET (N-ch). The P-ch MOSFET's gate is connected to a digital input signal through a pull-up resistor (R). The N-ch MOSFET's gate is connected to a standby mode control signal. The output of the P-ch MOSFET is labeled 'Digital output'. The output of the N-ch MOSFET is also labeled 'Digital output'. There are two LCD outputs, each with its own control signal. The control signals are connected to the gates of the MOSFETs through inverters.</p>	<ul style="list-style-type: none"> • CMOS level output • CMOS level hysteresis input • With input control • LCD common output • LCD segment output • With pull-up resistor control • With standby mode control • Pull-up resistor : Approximately 50kΩ • $I_{OH} = -4mA$, $I_{OL} = 4mA$
L	 <p>The circuit diagram for Type L is identical to the one for Type K. It shows a CMOS output stage with a pull-up resistor, digital input with a pull-up resistor, and two LCD outputs with control signals.</p>	<ul style="list-style-type: none"> • CMOS level output • CMOS level hysteresis input • With input control • LCD common output • With pull-up resistor control • With standby mode control • Pull-up resistor : Approximately 50kΩ • $I_{OH} = -4mA$, $I_{OL} = 4mA$

MB9AA30N Series

Type	Circuit	Remarks
O		<ul style="list-style-type: none"> • CMOS level output • CMOS level hysteresis input • With input control • Analog output • With pull-up resistor control • With standby mode control • Pull-up resistor : Approximately 50kΩ • $I_{OH} = -4\text{mA}$, $I_{OL} = 4\text{mA}$
Q		<ul style="list-style-type: none"> • CMOS level output • CMOS level hysteresis input • With input control • Analog input • LCD segment output • With pull-up resistor control • With standby mode control • Pull-up resistor : Approximately 50kΩ • $I_{OH} = -4\text{mA}$, $I_{OL} = 4\text{mA}$

MB9AA30N Series

Type	Circuit	Remarks
R	<p>The circuit diagram for Type R shows a central node connected to several components. At the top, a P-channel MOSFET (P-ch) is connected to a pull-up resistor and a digital output. Below it, another P-channel MOSFET (P-ch) is connected to a digital output. An N-channel MOSFET (N-ch) is connected to ground and also to a digital output. A pull-up resistor control signal is connected to the node between the two P-ch MOSFETs. A digital input signal, connected to a pull-up resistor R, is connected to an AND gate. The output of the AND gate is labeled as Standby mode control. An LCD VV input/output signal is connected to an inverter, which is then connected to an N-channel MOSFET. The gate of this MOSFET is also connected to the LCD VV control signal.</p>	<ul style="list-style-type: none"> • CMOS level output • CMOS level hysteresis input • With input control • LCD VV input/output • With pull-up resistor control • With standby mode control • Pull-up resistor : Approximately 50kΩ • $I_{OH} = -4\text{mA}$, $I_{OL} = 4\text{mA}$

■ HANDLING PRECAUTIONS

Any semiconductor devices have inherently a certain rate of failure. The possibility of failure is greatly affected by the conditions in which they are used (circuit conditions, environmental conditions, etc.). This page describes precautions that must be observed to minimize the chance of failure and to obtain higher reliability from your FUJITSU SEMICONDUCTOR semiconductor devices.

1. Precautions for Product Design

This section describes precautions when designing electronic equipment using semiconductor devices.

- **Absolute Maximum Ratings**

Semiconductor devices can be permanently damaged by application of stress (voltage, current, temperature, etc.) in excess of certain established limits, called absolute maximum ratings. Do not exceed these ratings.

- **Recommended Operating Conditions**

Recommended operating conditions are normal operating ranges for the semiconductor device. All the device's electrical characteristics are warranted when operated within these ranges.

Always use semiconductor devices within the recommended operating conditions. Operation outside these ranges may adversely affect reliability and could result in device failure.

No warranty is made with respect to uses, operating conditions, or combinations not represented on the data sheet. Users considering application outside the listed conditions are advised to contact their sales representative beforehand.

- **Processing and Protection of Pins**

These precautions must be followed when handling the pins which connect semiconductor devices to power supply and input/output functions.

- (1) **Preventing Over-Voltage and Over-Current Conditions**

Exposure to voltage or current levels in excess of maximum ratings at any pin is likely to cause deterioration within the device, and in extreme cases leads to permanent damage of the device. Try to prevent such overvoltage or over-current conditions at the design stage.

- (2) **Protection of Output Pins**

Shorting of output pins to supply pins or other output pins, or connection to large capacitance can cause large current flows. Such conditions if present for extended periods of time can damage the device.

Therefore, avoid this type of connection.

- (3) **Handling of Unused Input Pins**

Unconnected input pins with very high impedance levels can adversely affect stability of operation.

Such pins should be connected through an appropriate resistance to a power supply pin or ground pin.

- **Latch-up**

Semiconductor devices are constructed by the formation of P-type and N-type areas on a substrate. When subjected to abnormally high voltages, internal parasitic PNP junctions (called thyristor structures) may be formed, causing large current levels in excess of several hundred mA to flow continuously at the power supply pin. This condition is called latch-up.

CAUTION: The occurrence of latch-up not only causes loss of reliability in the semiconductor device, but can cause injury or damage from high heat, smoke or flame. To prevent this from happening, do the following:

- (1) Be sure that voltages applied to pins do not exceed the absolute maximum ratings. This should include attention to abnormal noise, surge levels, etc.

- (2) Be sure that abnormal current flows do not occur during the power-on sequence.

MB9AA30N Series

- **Observance of Safety Regulations and Standards**
Most countries in the world have established standards and regulations regarding safety, protection from electromagnetic interference, etc. Customers are requested to observe applicable regulations and standards in the design of products.
- **Fail-Safe Design**
Any semiconductor devices have inherently a certain rate of failure. You must protect against injury, damage or loss from such failures by incorporating safety design measures into your facility and equipment such as redundancy, fire protection, and prevention of over-current levels and other abnormal operating conditions.
- **Precautions Related to Usage of Devices**
FUJITSU SEMICONDUCTOR semiconductor devices are intended for use in standard applications (computers, office automation and other office equipment, industrial, communications, and measurement equipment, personal or household devices, etc.).

CAUTION: Customers considering the use of our products in special applications where failure or abnormal operation may directly affect human lives or cause physical injury or property damage, or where extremely high levels of reliability are demanded (such as aerospace systems, atomic energy controls, sea floor repeaters, vehicle operating controls, medical devices for life support, etc.) are requested to consult with sales representatives before such use. The company will not be responsible for damages arising from such use without prior approval.

2. Precautions for Package Mounting

Package mounting may be either lead insertion type or surface mount type. In either case, for heat resistance during soldering, you should only mount under FUJITSU SEMICONDUCTOR's recommended conditions. For detailed information about mount conditions, contact your sales representative.

- **Lead Insertion Type**
Mounting of lead insertion type packages onto printed circuit boards may be done by two methods: direct soldering on the board, or mounting by using a socket.

Direct mounting onto boards normally involves processes for inserting leads into through-holes on the board and using the flow soldering (wave soldering) method of applying liquid solder. In this case, the soldering process usually causes leads to be subjected to thermal stress in excess of the absolute ratings for storage temperature. Mounting processes should conform to FUJITSU SEMICONDUCTOR recommended mounting conditions.

If socket mounting is used, differences in surface treatment of the socket contacts and IC lead surfaces can lead to contact deterioration after long periods. For this reason it is recommended that the surface treatment of socket contacts and IC leads be verified before mounting.
- **Surface Mount Type**
Surface mount packaging has longer and thinner leads than lead-insertion packaging, and therefore leads are more easily deformed or bent. The use of packages with higher pin counts and narrower pin pitch results in increased susceptibility to open connections caused by deformed pins, or shorting due to solder bridges.

You must use appropriate mounting techniques. FUJITSU SEMICONDUCTOR recommends the solder reflow method, and has established a ranking of mounting conditions for each product. Users are advised to mount packages in accordance with FUJITSU SEMICONDUCTOR ranking of recommended conditions.

- **Lead-Free Packaging**

CAUTION: When ball grid array (BGA) packages with Sn-Ag-Cu balls are mounted using Sn-Pb eutectic soldering, junction strength may be reduced under some conditions of use.

- **Storage of Semiconductor Devices**

Because plastic chip packages are formed from plastic resins, exposure to natural environmental conditions will cause absorption of moisture. During mounting, the application of heat to a package that has absorbed moisture can cause surfaces to peel, reducing moisture resistance and causing packages to crack. To prevent, do the following:

- (1) Avoid exposure to rapid temperature changes, which cause moisture to condense inside the product. Store products in locations where temperature changes are slight.
- (2) Use dry boxes for product storage. Products should be stored below 70% relative humidity, and at temperatures between 5°C and 30°C.
When you open Dry Package that recommends humidity 40% to 70% relative humidity.
- (3) When necessary, FUJITSU SEMICONDUCTOR packages semiconductor devices in highly moisture-resistant aluminum laminate bags, with a silica gel desiccant. Devices should be sealed in their aluminum laminate bags for storage.
- (4) Avoid storing packages where they are exposed to corrosive gases or high levels of dust.

- **Baking**

Packages that have absorbed moisture may be de-moisturized by baking (heat drying). Follow the FUJITSU SEMICONDUCTOR recommended conditions for baking.

Condition: 125°C/24 h

- **Static Electricity**

Because semiconductor devices are particularly susceptible to damage by static electricity, you must take the following precautions:

- (1) Maintain relative humidity in the working environment between 40% and 70%. Use of an apparatus for ion generation may be needed to remove electricity.
- (2) Electrically ground all conveyors, solder vessels, soldering irons and peripheral equipment.
- (3) Eliminate static body electricity by the use of rings or bracelets connected to ground through high resistance (on the level of 1 MΩ).
Wearing of conductive clothing and shoes, use of conductive floor mats and other measures to minimize shock loads is recommended.
- (4) Ground all fixtures and instruments, or protect with anti-static measures.
- (5) Avoid the use of styrofoam or other highly static-prone materials for storage of completed board assemblies.

3. Precautions for Use Environment

Reliability of semiconductor devices depends on ambient temperature and other conditions as described above.

For reliable performance, do the following:

(1) Humidity

Prolonged use in high humidity can lead to leakage in devices as well as printed circuit boards. If high humidity levels are anticipated, consider anti-humidity processing.

(2) Discharge of Static Electricity

When high-voltage charges exist close to semiconductor devices, discharges can cause abnormal operation. In such cases, use anti-static measures or processing to prevent discharges.

(3) Corrosive Gases, Dust, or Oil

Exposure to corrosive gases or contact with dust or oil may lead to chemical reactions that will adversely affect the device. If you use devices in such conditions, consider ways to prevent such exposure or to protect the devices.

(4) Radiation, Including Cosmic Radiation

Most devices are not designed for environments involving exposure to radiation or cosmic radiation. Users should provide shielding as appropriate.

(5) Smoke, Flame

CAUTION: Plastic molded devices are flammable, and therefore should not be used near combustible substances. If devices begin to smoke or burn, there is danger of the release of toxic gases.

Customers considering the use of FUJITSU SEMICONDUCTOR products in other special environmental conditions should consult with sales representatives.

Please check the latest handling precautions at the following URL.

<http://edevice.fujitsu.com/fj/handling-e.pdf>

■ HANDLING DEVICES

• Power supply pins

In products with multiple VCC and VSS pins, respective pins at the same potential are interconnected within the device in order to prevent malfunctions such as latch-up. However, all of these pins should be connected externally to the power supply or ground lines in order to reduce electromagnetic emission levels, to prevent abnormal operation of strobe signals caused by the rise in the ground level, and to conform to the total output current rating.

Moreover, connect the current supply source with each Power supply pins and GND pins of this device at low impedance. It is also advisable that a ceramic capacitor of approximately 0.1 μF be connected as a bypass capacitor between each Power supply pin and GND pin near this device.

• Crystal oscillator circuit

Noise near the X0/X1 and X0A/X1A pins may cause the device to malfunction. Design the printed circuit board so that X0/X1, X0A/X1A pins, the crystal oscillator, and the bypass capacitor to ground are located as close to the device as possible.

It is strongly recommended that the PC board artwork be designed such that the X0/X1 and X0A/X1A pins are surrounded by ground plane as this is expected to produce stable operation.

• Using an external clock

To use the external clock, set general-purpose I/O ports to input the clock to X0/PE2 and X0A/P46 pin.

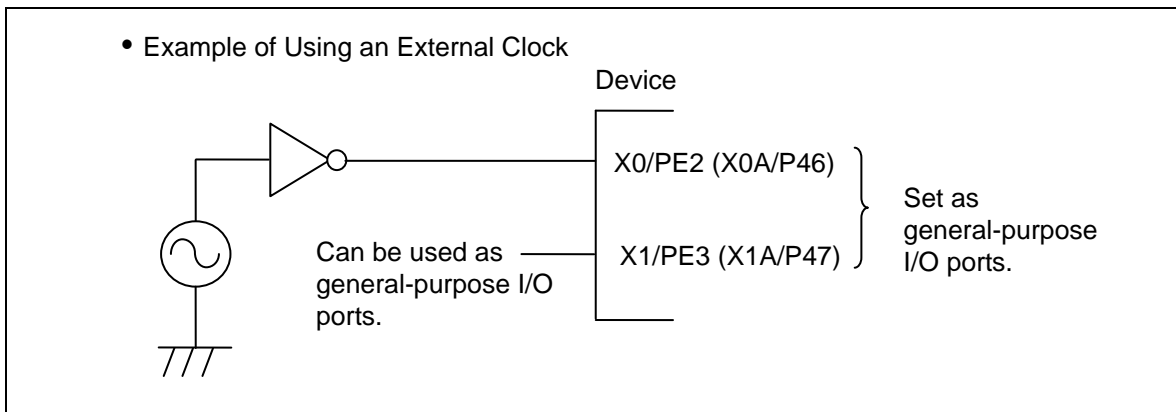

• Handling when using Multi-function serial pin as I²C pin

If it is using the multi-function serial pin as I²C pins, P-ch transistor of digital output is always disable. However, I²C pins need to keep the electrical characteristic like other pins and not to connect to the external I²C bus system with power OFF.

MB9AA30N Series

- C Pin

This series contains the regulator. Be sure to connect a smoothing capacitor (C_S) for the regulator between the C pin and the GND pin. Please use a ceramic capacitor or a capacitor of equivalent frequency characteristics as a smoothing capacitor.

However, some laminated ceramic capacitors have the characteristics of capacitance variation due to thermal fluctuation (F characteristics and Y5V characteristics). Please select the capacitor that meets the specifications in the operating conditions to use by evaluating the temperature characteristics of a capacitor.

A smoothing capacitor of about $4.7\mu\text{F}$ would be recommended for this series.

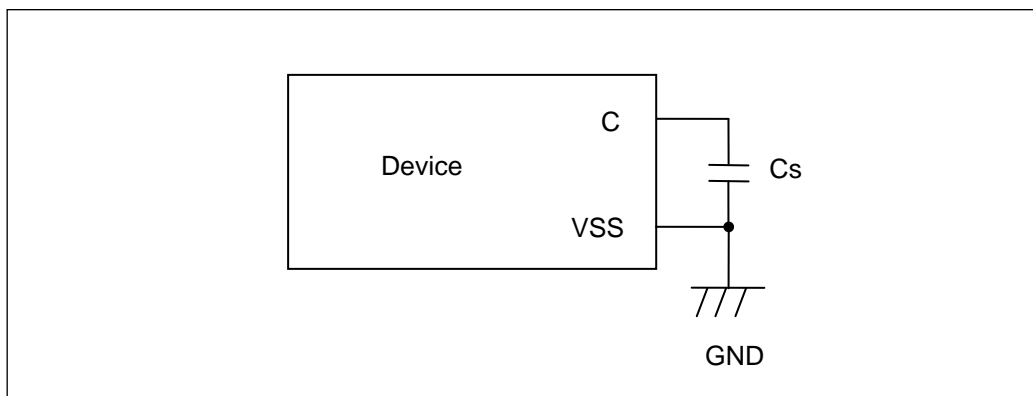

- Mode pins (MD0, MD1)

Connect the MD pin (MD0, MD1) directly to VCC or VSS pins. Design the printed circuit board such that the pull-up/down resistance stays low, as well as the distance between the mode pins and VCC pins or VSS pins is as short as possible and the connection impedance is low, when the pins are pulled-up/down such as for switching the pin level and rewriting the Flash memory data. It is because of preventing the device erroneously switching to test mode due to noise.

- Notes on power-on

Turn power on/off in the following order or at the same time.

If not using the A/D converter, connect $AVCC = VCC$ and $AVSS = VSS$.

Turning on : $VCC \rightarrow AVCC \rightarrow AVRH$

Turning off : $AVRH \rightarrow AVCC \rightarrow VCC$

- Serial Communication

There is a possibility to receive wrong data due to the noise or other causes on the serial communication. Therefore, design a printed circuit board so as to avoid noise.

Consider the case of receiving wrong data due to noise, perform error detection such as by applying a checksum of data at the end. If an error is detected, retransmit the data.

- Differences in features among the products with different memory sizes and between Flash memory products and MASK products

The electric characteristics including power consumption, ESD, latch-up, noise characteristics, and oscillation characteristics among the products with different memory sizes and between Flash memory products and MASK products are different because chip layout and memory structures are different.

If you are switching to use a different product of the same series, please make sure to evaluate the electric characteristics.

■ BLOCK DIAGRAM

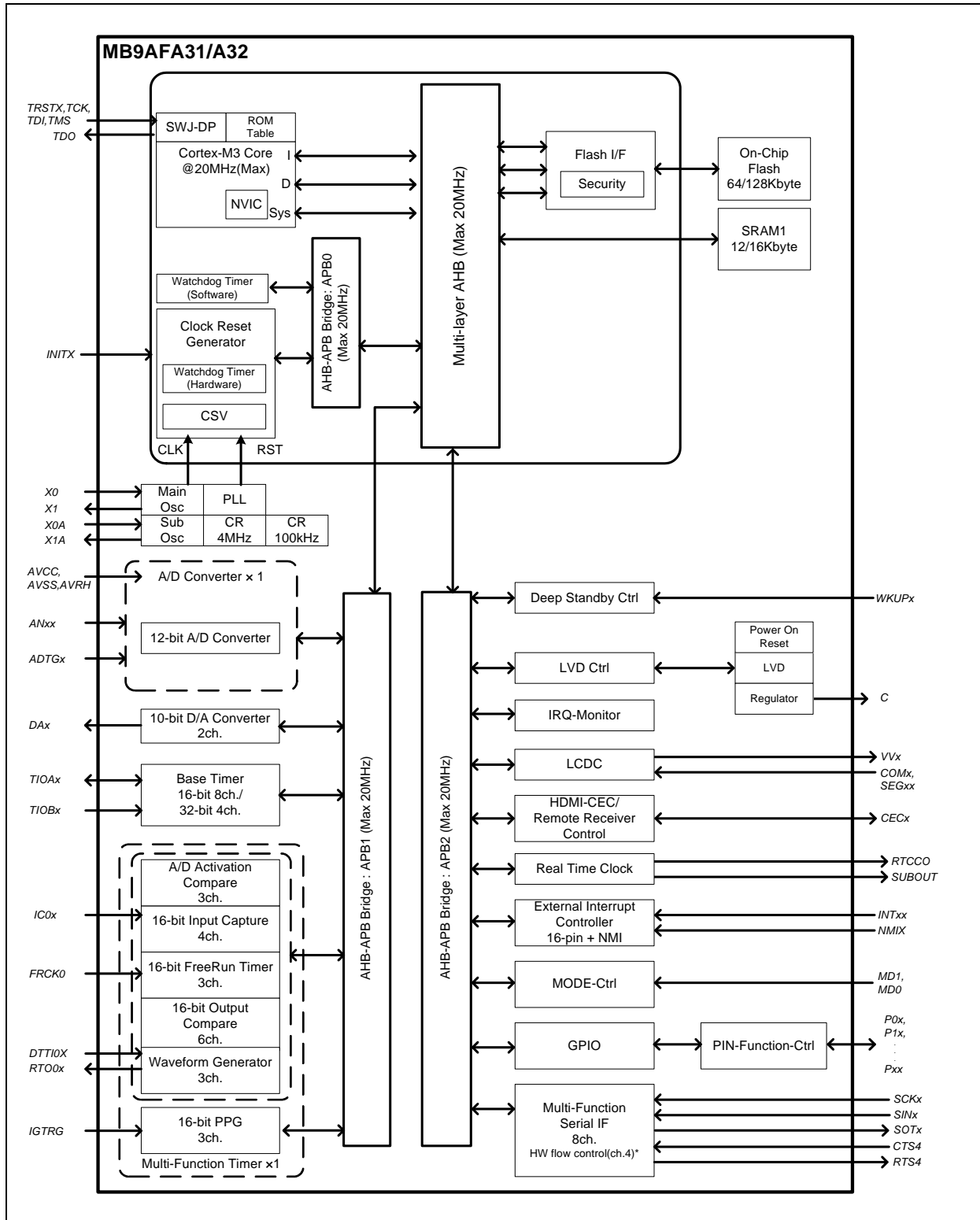

*: For the MB9AFA31L and MB9AFA32L, Multi-function Serial Interface does not support hardware flow control in these products.

■ MEMORY SIZE

See " • Memory size" in "■PRODUCT LINEUP" to confirm the memory size.

MB9AA30N Series

■ MEMORY MAP

• Memory Map (1)

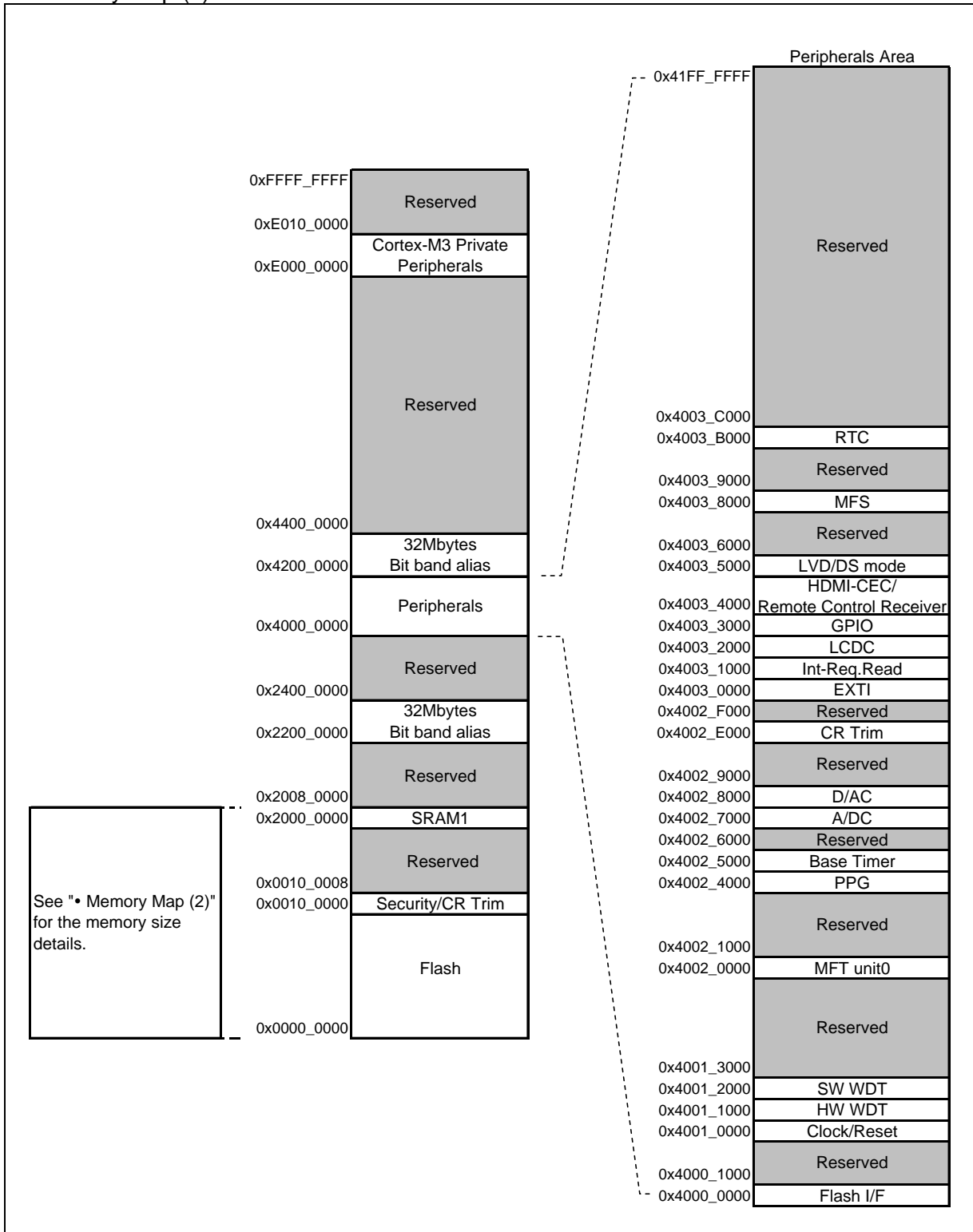

MB9AA30N Series

• Memory Map (2)

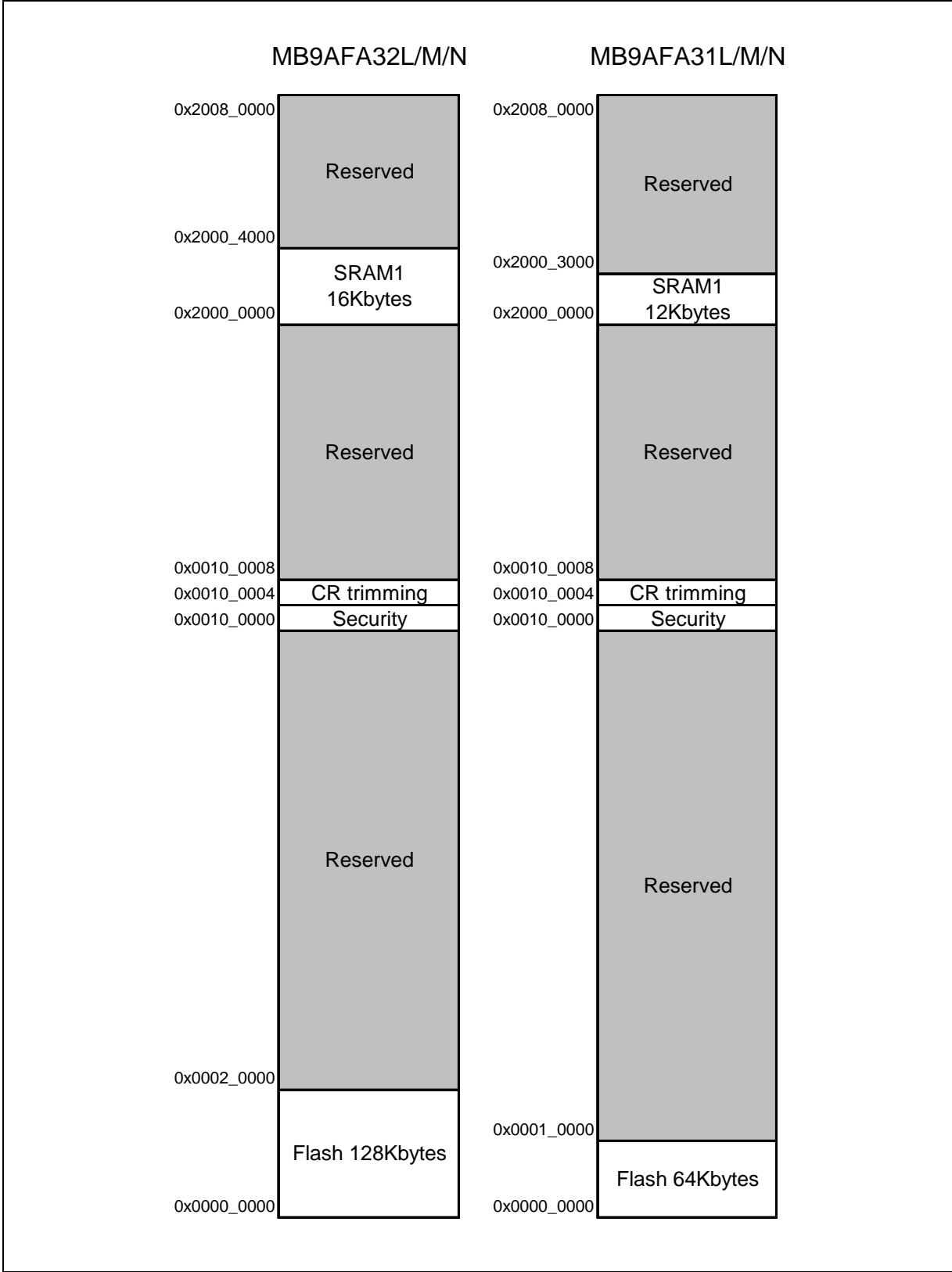

MB9AA30N Series

• Peripheral Address Map

Start address	End address	Bus	Peripherals	
0x4000_0000	0x4000_0FFF	AHB	Flash memory I/F register	
0x4000_1000	0x4000_FFFF		Reserved	
0x4001_0000	0x4001_0FFF	APB0	Clock/Reset Control	
0x4001_1000	0x4001_1FFF		Hardware Watchdog timer	
0x4001_2000	0x4001_2FFF		Software Watchdog timer	
0x4001_3000	0x4001_4FFF		Reserved	
0x4001_5000	0x4001_5FFF		Reserved	
0x4001_6000	0x4001_FFFF		Reserved	
0x4002_0000	0x4002_0FFF		APB1	Multi-function timer unit0
0x4002_1000	0x4002_1FFF	Reserved		
0x4002_2000	0x4002_3FFF	Reserved		
0x4002_4000	0x4002_4FFF	PPG		
0x4002_5000	0x4002_5FFF	Base Timer		
0x4002_6000	0x4002_6FFF	Reserved		
0x4002_7000	0x4002_7FFF	A/D Converter		
0x4002_8000	0x4002_8FFF	D/A Converter		
0x4002_9000	0x4002_DFFF	Reserved		
0x4002_E000	0x4002_EFFF	Built-in CR trimming		
0x4002_F000	0x4002_FFFF	Reserved		
0x4003_0000	0x4003_0FFF	APB2		External Interrupt
0x4003_1000	0x4003_1FFF			Interrupt Source Check Register
0x4003_2000	0x4003_2FFF			LCD Controller
0x4003_3000	0x4003_3FFF		GPIO	
0x4003_4000	0x4003_4FFF		HDMI-CEC/ Remote Control Receiver	
0x4003_5000	0x4003_50FF		Low-Voltage Detector	
0x4003_5100	0x4003_5FFF		Deep standby mode Controller	
0x4003_6000	0x4003_6FFF		Reserved	
0x4003_7000	0x4003_7FFF		Reserved	
0x4003_8000	0x4003_8FFF		Multi-function serial	
0x4003_9000	0x4003_9FFF		Reserved	
0x4003_A000	0x4003_AFFF		Reserved	
0x4003_B000	0x4003_BFFF		Real-time clock	
0x4003_C000	0x4003_FFFF		Reserved	
0x4004_0000	0x4004_FFFF		AHB	Reserved
0x4005_0000	0x4005_FFFF	Reserved		
0x4006_0000	0x4006_0FFF	Reserved		
0x4006_1000	0x4006_1FFF	Reserved		
0x4006_2000	0x4006_2FFF	Reserved		
0x4006_3000	0x4006_3FFF	Reserved		
0x4006_4000	0x41FF_FFFF	Reserved		

■ PIN STATUS IN EACH CPU STATE

The terms used for pin status have the following meanings.

- INITX = 0
This is the period when the INITX pin is the "L" level.
- INITX = 1
This is the period when the INITX pin is the "H" level.
- SPL = 0
This is the status that the standby pin level setting bit (SPL) in the standby mode control register (STB_CTL) is set to "0".
- SPL = 1
This is the status that the standby pin level setting bit (SPL) in the standby mode control register (STB_CTL) is set to "1".
- Input enabled
Indicates that the input function can be used.
- Internal input fixed at "0"
This is the status that the input function cannot be used. Internal input is fixed at "L".
- Hi-Z
Indicates that the pin drive transistor is disabled and the pin is put in the Hi-Z state.
- Setting disabled
Indicates that the setting is disabled.
- Maintain previous state
Maintains the state that was immediately prior to entering the current mode.
If a built-in peripheral function is operating, the output follows the peripheral function.
If the pin is being used as a port, that output is maintained.
- Analog input is enabled
Indicates that the analog input is enabled.
- Trace output
Indicates that the trace function can be used.
- GPIO selected
In Deep standby mode, pins switch to the general-purpose I/O port.

MB9AA30N Series

• List of Pin Status

Pin status type	Function group	Power-on reset or low-voltage detection state	INITX input state	Device internal reset state	Run mode or SLEEP mode state	Timer mode, RTC mode, or STOP mode state		Deep standby RTC mode or Deep standby STOP mode state		Return from Deep standby mode state
		Power supply unstable	Power supply stable		Power supply stable	Power supply stable		Power supply stable		Power supply stable
		-	INITX = 0	INITX = 1	INITX = 1	INITX = 1		INITX = 1		INITX = 1
		-	-	-	-	SPL = 0	SPL = 1	SPL = 0	SPL = 1	-
A	Main crystal oscillator input pin	Input enabled	Input enabled	Input enabled	Input enabled	Input enabled	Input enabled	Input enabled	Input enabled	Input enabled
	External main clock input selected	Setting disabled	Setting disabled	Setting disabled	Maintain previous state	Maintain previous state / When oscillation stops* ¹ , output maintains previous state / Internal input fixed at "0"	Hi-Z / Input enabled / When oscillation stops* ¹ , Hi-Z / Internal input fixed at "0"	Output maintains previous state / Internal input fixed at "0"	Hi-Z / Internal input fixed at "0"	GPIO selected
	GPIO selected	Setting disabled	Setting disabled	Setting disabled	Maintain previous state	Output maintains previous state / Internal input fixed at "0"	Hi-Z / Internal input fixed at "0"	Output maintains previous state / Internal input fixed at "0"	Hi-Z / Internal input fixed at "0"	Maintain previous state
B	Main crystal oscillator output pin	Hi-Z / Internal input fixed at "0"	Hi-Z / Internal input fixed at "0"	Hi-Z / Internal input fixed at "0"	Maintain previous state / When oscillation stops* ¹ , Hi-Z output / Internal input fixed at "0"	Maintain previous state / When oscillation stops* ¹ , Hi-Z output / Internal input fixed at "0"	Maintain previous state / When oscillation stops* ¹ , Hi-Z output / Internal input fixed at "0"	Maintain previous state / When oscillation stops* ¹ , Hi-Z output / Internal input fixed at "0"	Maintain previous state / When oscillation stops* ¹ , Hi-Z output / Internal input fixed at "0"	Maintain previous state / When oscillation stops* ¹ , Hi-Z output / Internal input fixed at "0"
	GPIO selected	Setting disabled	Setting disabled	Setting disabled	Maintain previous state	Maintain previous state	Hi-Z / Internal input fixed at "0"	Output maintains previous state / Internal input fixed at "0"	Hi-Z / Internal input fixed at "0"	Maintain previous state
C	INITX input pin	Pull-up / Input enabled	Pull-up / Input enabled	Pull-up / Input enabled	Pull-up / Input enabled	Pull-up / Input enabled	Pull-up / Input enabled	Pull-up / Input enabled	Pull-up / Input enabled	Pull-up / Input enabled

MB9AA30N Series

Pin status type	Function group	Power-on reset or low-voltage detection state	INITX input state	Device internal reset state	Run mode or SLEEP mode state	Timer mode, RTC mode, or STOP mode state		Deep standby RTC mode or Deep standby STOP mode state		Return from Deep standby mode state
		Power supply unstable	Power supply stable		Power supply stable	Power supply stable		Power supply stable		Power supply stable
		-	INITX = 0	INITX = 1	INITX = 1	INITX = 1		INITX = 1		INITX = 1
		-	-	-	-	SPL = 0	SPL = 1	SPL = 0	SPL = 1	-
D	Mode input pin	Input enabled	Input enabled	Input enabled	Input enabled	Input enabled	Input enabled	Input enabled	Input enabled	Input enabled
E	JTAG selected	Hi-Z	Pull-up / Input enabled	Pull-up / Input enabled	Maintain previous state	Maintain previous state	Maintain previous state	Maintain previous state	Maintain previous state	Maintain previous state
	GPIO selected	Setting disabled	Setting disabled	Setting disabled			Hi-Z / Internal input fixed at "0"	Output maintain previous state / Internal input fixed at "0"	Hi-Z / Internal input fixed at "0"	
F	External interrupt enabled selected	Setting disabled	Setting disabled	Setting disabled	Maintain previous state	Maintain previous state	Maintain previous state	GPIO selected Internal input fixed at "0"	Hi-Z / Internal input fixed at "0"	GPIO selected
	Resource other than above selected	Hi-Z	Hi-Z / Input enabled	Hi-Z / Input enabled			Hi-Z / Internal input fixed at "0"			
	GPIO selected						Maintain previous state			
G	WKUP enabled	Setting disabled	Setting disabled	Setting disabled	Maintain previous state	Maintain previous state	Hi-Z / Internal input fixed at "0"	WKUP input enabled	Hi-Z / WKUP input enabled	GPIO selected
	External interrupt enabled selected	Setting disabled	Setting disabled	Setting disabled			Maintain previous state	GPIO selected Internal input fixed at "0"	Hi-Z / Internal input fixed at "0"	GPIO selected
	Resource other than above selected	Hi-Z	Hi-Z / Input enabled	Hi-Z / Input enabled			Hi-Z / Internal input fixed at "0"			
	GPIO selected						Maintain previous state			

MB9AA30N Series

Pin status type	Function group	Power-on reset or low-voltage detection state	INITX input state	Device internal reset state	Run mode or SLEEP mode state	Timer mode, RTC mode, or STOP mode state		Deep standby RTC mode or Deep standby STOP mode state		Return from Deep standby mode state	
		Power supply unstable	Power supply stable		Power supply stable	Power supply stable		Power supply stable		Power supply stable	
		-	INITX = 0	INITX = 1	INITX = 1	INITX = 1		INITX = 1		INITX = 1	
		-	-	-	-	SPL = 0	SPL = 1	SPL = 0	SPL = 1	-	
H	Resource selected	Hi-Z	Hi-Z / Input enabled	Hi-Z / Input enabled	Maintain previous state	Maintain previous state	Hi-Z / Internal input fixed at "0"	GPIO selected Internal input fixed at "0"	Hi-Z / Internal input fixed at "0"	GPIO selected	
	GPIO selected		Output maintains previous state / Internal input fixed at "0"	Maintain previous state							
I	NMIX selected	Setting disabled	Setting disabled	Setting disabled	Maintain previous state	Maintain previous state	Maintain previous state	WKUP input enabled	Hi-Z / WKUP input enabled	GPIO selected	
	Resource other than above selected	Hi-Z	Hi-Z / Input enabled	Hi-Z / Input enabled			Hi-Z / Internal input fixed at "0"				Maintain previous state
	GPIO selected	Maintain previous state									
J	Analog input selected	Hi-Z	Hi-Z / Internal input fixed at "0" / Analog input enabled	Hi-Z / Internal input fixed at "0" / Analog input enabled	Hi-Z / Internal input fixed at "0" / Analog input enabled	Hi-Z / Internal input fixed at "0" / Analog input enabled	Hi-Z / Internal input fixed at "0" / Analog input enabled	Hi-Z / Internal input fixed at "0" / Analog input enabled	Hi-Z / Internal input fixed at "0" / Analog input enabled	Hi-Z / Internal input fixed at "0" / Analog input enabled	
	Resource other than above selected		Setting disabled	Setting disabled	Setting disabled	Maintain previous state	Maintain previous state	Hi-Z / Internal input fixed at "0"	GPIO selected Internal input fixed at "0"	Hi-Z / Internal input fixed at "0"	GPIO selected Internal input fixed at "0"
	GPIO selected							Output maintains previous state / Internal input fixed at "0"	Output maintains previous state / Internal input fixed at "0"		

MB9AA30N Series

Pin status type	Function group	Power-on reset or low-voltage detection state	INITX input state	Device internal reset state	Run mode or SLEEP mode state	Timer mode, RTC mode, or STOP mode state		Deep standby RTC mode or Deep standby STOP mode state		Return from Deep standby mode state
		Power supply unstable	Power supply stable		Power supply stable	Power supply stable		Power supply stable		Power supply stable
		-	INITX = 0	INITX = 1	INITX = 1	INITX = 1		INITX = 1		INITX = 1
		-	-	-	-	SPL = 0	SPL = 1	SPL = 0	SPL = 1	-
K	Analog input selected	Hi-Z	Hi-Z / Internal input fixed at "0" / Analog input enabled	Hi-Z / Internal input fixed at "0" / Analog input enabled	Hi-Z / Internal input fixed at "0" / Analog input enabled	Hi-Z / Internal input fixed at "0" / Analog input enabled	Hi-Z / Internal input fixed at "0" / Analog input enabled	Hi-Z / Internal input fixed at "0" / Analog input enabled	Hi-Z / Internal input fixed at "0" / Analog input enabled	Hi-Z / Internal input fixed at "0" / Analog input enabled
	External interrupt enabled selected	Setting disabled	Setting disabled	Setting disabled	Maintain previous state	Maintain previous state	Maintain previous state	GPIO selected Internal input fixed at "0"	Hi-Z / Internal input fixed at "0"	GPIO selected Internal input fixed at "0"
	Resource other than above selected						Hi-Z / Internal input fixed at "0"			
GPIO selected										Output maintains previous state / Internal input fixed at "0"
L	Analog input selected	Hi-Z	Hi-Z / Internal input fixed at "0" / Analog input enabled	Hi-Z / Internal input fixed at "0" / Analog input enabled	Hi-Z / Internal input fixed at "0" / Analog input enabled	Hi-Z / Internal input fixed at "0" / Analog input enabled	Hi-Z / Internal input fixed at "0" / Analog input enabled	Hi-Z / Internal input fixed at "0" / Analog input enabled	Hi-Z / Internal input fixed at "0" / Analog input enabled	Hi-Z / Internal input fixed at "0" / Analog input enabled
	WKUP enabled	Setting disabled	Setting disabled	Setting disabled	Maintain previous state	Maintain previous state	Hi-Z / Internal input fixed at "0"	WKUP input enabled	Hi-Z / WKUP input enabled	GPIO selected Internal input fixed at "0"
	External interrupt enabled selected						Maintain previous state	GPIO selected Internal input fixed at "0"	Hi-Z / Internal input fixed at "0"	
	Resource other than above selected						Hi-Z / Internal input fixed at "0"			
GPIO selected										Output maintains previous state / Internal input fixed at "0"

MB9AA30N Series

Pin status type	Function group	Power-on reset or low-voltage detection state	INITX input state	Device internal reset state	Run mode or SLEEP mode state	Timer mode, RTC mode, or STOP mode state		Deep standby RTC mode or Deep standby STOP mode state		Return from Deep standby mode state
		Power supply unstable	Power supply stable		Power supply stable	Power supply stable		Power supply stable		Power supply stable
		-	INITX = 0	INITX = 1	INITX = 1	INITX = 1		INITX = 1		INITX = 1
		-	-	-	-	SPL = 0	SPL = 1	SPL = 0	SPL = 1	-
M	Sub crystal oscillator input pin	Input enabled	Input enabled	Input enabled	Input enabled	Input enabled	Input enabled	Input enabled	Input enabled	Input enabled
	External sub clock input selected	Setting disabled	Setting disabled	Setting disabled	Maintain previous state	Maintain previous state / When oscillation stops* ² , output maintains previous state / Internal input fixed at "0"	Hi-Z / Input enabled / When oscillation stops* ² , Hi-Z / Internal input fixed at "0"	Maintain previous state / When oscillation stops* ² , output maintains previous state / Internal input fixed at "0"	Hi-Z / Input enabled / When oscillation stops* ² , Hi-Z / Internal input fixed at "0"	Maintain previous state / When Return from Deep Standby STOP mode, GPIO is selected
	GPIO selected	Setting disabled	Setting disabled	Setting disabled	Maintain previous state	Output maintains previous state / Internal input fixed at "0"	Hi-Z / Internal input fixed at "0"	Output maintains previous state / Internal input fixed at "0"	Hi-Z / Internal input fixed at "0"	Maintain previous state
N	Sub crystal oscillator output pin	Hi-Z / Internal input fixed at "0"	Hi-Z / Internal input fixed at "0"	Hi-Z / Internal input fixed at "0"	Maintain previous state	Maintain previous state / When oscillation stops* ² , Hi-Z / Internal input fixed at "0"	Maintain previous state / When oscillation stops* ² , Hi-Z / Internal input fixed at "0"	Maintain previous state / When oscillation stops* ² , Hi-Z / Internal input fixed at "0"	Maintain previous state / When oscillation stops* ² , Hi-Z / Internal input fixed at "0"	Maintain previous state / When oscillation stops* ² , Hi-Z / Internal input fixed at "0"
	GPIO selected	Setting disabled	Setting disabled	Setting disabled	Maintain previous state	Maintain previous state	Hi-Z / Internal input fixed at "0"	Output maintains previous state / Internal input fixed at "0"	Hi-Z / Internal input fixed at "0"	Maintain previous state

MB9AA30N Series

Pin status type	Function group	Power-on reset or low-voltage detection state	INITX input state	Device internal reset state	Run mode or SLEEP mode state	Timer mode, RTC mode, or STOP mode state		Deep standby RTC mode or Deep standby STOP mode state		Return from Deep standby mode state
		Power supply unstable	Power supply stable		Power supply stable	Power supply stable		Power supply stable		Power supply stable
		-	INITX = 0	INITX = 1	INITX = 1	INITX = 1		INITX = 1		INITX = 1
		-	-	-	-	SPL = 0	SPL = 1	SPL = 0	SPL = 1	-
O	External interrupt enabled selected	Setting disabled	Setting disabled	Setting disabled	Maintain previous state	Maintain previous state	Maintain previous state	GPIO selected / Internal input fixed at "0"	Hi-Z / Internal input fixed at "0"	GPIO selected
	GPIO selected	Hi-Z	Hi-Z / Input enabled	Hi-Z / Input enabled			Hi-Z / Internal input fixed at "0"	Output maintains previous state / Internal input fixed at "0"		Maintain previous state
P	Mode input pin	Input enabled	Input enabled	Input enabled	Input enabled	Input enabled	Input enabled	Input enabled	Input enabled	Input enabled
	GPIO selected	Setting disabled	Setting disabled	Setting disabled	Maintain previous state	Maintain previous state	Hi-Z / Input enabled	Maintain previous state	Hi-Z / Input enabled	Maintain previous state
Q	CEC enabled	Setting disabled	Setting disabled	Setting disabled	Maintain previous state	Maintain previous state	Maintain previous state	Maintain previous state	Maintain previous state	Maintain previous state
	Resource other than above selected	Hi-Z	Hi-Z / Input enabled	Hi-Z / Input enabled	Maintain previous state	Maintain previous state	Hi-Z / Internal input fixed at "0"	GPIO selected / Internal input fixed at "0"	Hi-Z / Internal input fixed at "0"	GPIO selected
GPIO selected	Output maintains previous state / Internal input fixed at "0"						Maintain previous state			

MB9AA30N Series

Pin status type	Function group	Power-on reset or low-voltage detection state	INITX input state	Device internal reset state	Run mode or SLEEP mode state	Timer mode, RTC mode, or STOP mode state		Deep standby RTC mode or Deep standby STOP mode state		Return from Deep standby mode state		
		Power supply unstable	Power supply stable		Power supply stable	Power supply stable		Power supply stable		Power supply stable		
		-	INITX = 0	INITX = 1	INITX = 1	INITX = 1		INITX = 1		INITX = 1		
		-	-	-	-	SPL = 0	SPL = 1	SPL = 0	SPL = 1	-		
R	CEC enabled	Setting disabled	Setting disabled	Setting disabled	Maintain previous state	Maintain previous state	Maintain previous state	Maintain previous state	Maintain previous state	Maintain previous state		
	WKUP enabled	Setting disabled	Setting disabled	Setting disabled	Maintain previous state	Maintain previous state	Hi-Z / Internal input fixed at "0"	WKUP input enabled	Hi-Z / WKUP input enabled	GPIO selected		
	External interrupt enabled selected						Maintain previous state	GPIO selected	Internal input fixed at "0"			
	Resource other than above selected	Hi-Z	Hi-Z / Input enabled	Hi-Z / Input enabled			Maintain previous state	Hi-Z / Internal input fixed at "0"	Output maintains previous state / Internal input fixed at "0"		Hi-Z / Internal input fixed at "0"	Maintain previous state
	GPIO selected						Hi-Z / Internal input fixed at "0"	Hi-Z / Internal input fixed at "0"				
Hi-Z / Internal input fixed at "0"												
	S	External interrupt enabled selected	Setting disabled	Setting disabled	Setting disabled	Maintain previous state	Maintain previous state	Maintain previous state	GPIO selected	Internal input fixed at "0"	Hi-Z / Internal input fixed at "0"	GPIO selected
Resource other than above selected		Hi-Z	Hi-Z / Internal input fixed at "0"	Hi-Z / Internal input fixed at "0"	Hi-Z / Internal input fixed at "0"			Hi-Z / Internal input fixed at "0"	Output maintains previous state / Internal input fixed at "0"	Hi-Z / Internal input fixed at "0"	Output maintains previous state / Internal input fixed at "0"	
GPIO selected												Hi-Z / Internal input fixed at "0"

MB9AA30N Series

Pin status type	Function group	Power-on reset or low-voltage detection state	INITX input state	Device internal reset state	Run mode or SLEEP mode state	Timer mode, RTC mode, or STOP mode state		Deep standby RTC mode or Deep standby STOP mode state		Return from Deep standby mode state
		Power supply unstable	Power supply stable		Power supply stable	Power supply stable		Power supply stable		Power supply stable
		-	INITX = 0	INITX = 1	INITX = 1	INITX = 1		INITX = 1		INITX = 1
		-	-	-	-	SPL = 0	SPL = 1	SPL = 0	SPL = 1	-
T	WKUP enabled	Setting disabled	Setting disabled	Setting disabled	Maintain previous state	Maintain previous state	Hi-Z / Internal input fixed at "0"	WKUP input enabled	Hi-Z / WKUP input enabled	GPIO selected Internal input fixed at "0"
	External interrupt enabled selected	Setting disabled	Setting disabled	Setting disabled			Maintain previous state	GPIO selected Internal input fixed at "0"	Hi-Z / Internal input fixed at "0"	GPIO selected Internal input fixed at "0"
	Resource other than above selected	Hi-Z	Hi-Z / Internal input fixed at "0"	Hi-Z / Internal input fixed at "0"			Hi-Z / Internal input fixed at "0"	Output maintains previous state / Internal input fixed at "0"		Output maintains previous state / Internal input fixed at "0"
	GPIO selected									
U	Resource selected	Hi-Z	Hi-Z / Internal input fixed at "0"	Hi-Z / Internal input fixed at "0"	Maintain previous state	Maintain previous state	Hi-Z / Internal input fixed at "0"	GPIO selected Internal input fixed at "0"	Hi-Z / Internal input fixed at "0"	GPIO selected Internal input fixed at "0"
	GPIO selected							Output maintains previous state / Internal input fixed at "0"		Output maintains previous state / Internal input fixed at "0"
V	Resource selected	Hi-Z	Hi-Z / Internal input fixed at "0"	Hi-Z / Internal input fixed at "0"	Maintain previous state	Maintain previous state	Hi-Z / Internal input fixed at "0"	GPIO selected Internal input fixed at "0"	Hi-Z / Internal input fixed at "0"	Hi-Z / Internal input fixed at "0"
	GPIO selected							Output maintains previous state / Internal input fixed at "0"		

MB9AA30N Series

Pin status type	Function group	Power-on reset or low-voltage detection state	INITX input state	Device internal reset state	Run mode or SLEEP mode state	Timer mode, RTC mode, or STOP mode state		Deep standby RTC mode or Deep standby STOP mode state		Return from Deep standby mode state		
		Power supply unstable	Power supply stable		Power supply stable	Power supply stable		Power supply stable		Power supply stable		
		-	INITX = 0	INITX = 1	INITX = 1	INITX = 1		INITX = 1		INITX = 1		
		-	-	-	-	SPL = 0	SPL = 1	SPL = 0	SPL = 1	-		
W	External interrupt enabled selected	Setting disabled	Setting disabled	Setting disabled	Maintain previous state	Maintain previous state	Maintain previous state	GPIO selected Internal input fixed at "0"	Hi-Z / Internal input fixed at "0"	Hi-Z / Internal input fixed at "0"		
	Resource other than above selected	Hi-Z	Hi-Z / Internal input fixed at "0"	Hi-Z / Internal input fixed at "0"			Maintain previous state				Hi-Z / Internal input fixed at "0"	Output maintains previous state / Internal input fixed at "0"
	GPIO selected											
X	Analog input selected	Hi-Z	Hi-Z / Internal input fixed at "0" / Analog input enabled	Hi-Z / Internal input fixed at "0" / Analog input enabled	Hi-Z / Internal input fixed at "0" / Analog input enabled	Hi-Z / Internal input fixed at "0" / Analog input enabled	Hi-Z / Internal input fixed at "0" / Analog input enabled	Hi-Z / Internal input fixed at "0" / Analog input enabled	Hi-Z / Internal input fixed at "0" / Analog input enabled	Hi-Z / Internal input fixed at "0" / Analog input enabled		
	Resource other than above selected	Setting disabled	Setting disabled	Setting disabled	Maintain previous state	Maintain previous state	Hi-Z / Internal input fixed at "0"	GPIO selected Internal input fixed at "0"	Hi-Z / Internal input fixed at "0"	GPIO selected		
	GPIO selected							Output maintains previous state / Internal input fixed at "0"			Maintain previous state	

MB9AA30N Series

Pin status type	Function group	Power-on reset or low-voltage detection state	INITX input state	Device internal reset state	Run mode or SLEEP mode state	Timer mode, RTC mode, or STOP mode state		Deep standby RTC mode or Deep standby STOP mode state		Return from Deep standby mode state	
		Power supply unstable	Power supply stable		Power supply stable	Power supply stable		Power supply stable		Power supply stable	
		-	INITX = 0	INITX = 1	INITX = 1	INITX = 1		INITX = 1		INITX = 1	
		-	-	-	-	SPL = 0	SPL = 1	SPL = 0	SPL = 1	-	
Y	Analog output selected	Setting disabled	Setting disabled	Setting disabled	Maintain previous state	*3	*4	GPIO selected Internal input fixed at "0"	Hi-Z / Internal input fixed at "0"	GPIO selected	
	External interrupt enabled selected	Setting disabled	Setting disabled	Setting disabled		Maintain previous state					
	Resource other than above selected	Hi-Z	Hi-Z / Input enabled	Hi-Z / Input enabled		Maintain previous state	Hi-Z / Internal input fixed at "0"				Output maintains previous state / Internal input fixed at "0"
	GPIO selected										
Z	Analog output selected	Setting disabled	Setting disabled	Setting disabled	Maintain previous state	*3	*4	GPIO selected Internal input fixed at "0"	Hi-Z / Internal input fixed at "0"	GPIO selected	
	Resource other than above selected	Hi-Z	Hi-Z / Input enabled	Hi-Z / Input enabled		Maintain previous state	Hi-Z / Internal input fixed at "0"				Output maintains previous state / Internal input fixed at "0"
	GPIO selected										

*1 : Oscillation is stopped at Sub run mode, Low-speed CR run mode, Sub SLEEP mode, Low-speed CR SLEEP mode, Sub timer mode, Low-speed CR timer mode, RTC mode, STOP mode, Deep standby RTC mode, and Deep standby STOP mode.

*2 : Oscillation is stopped at STOP mode and Deep standby STOP mode.

*3 : Maintain previous state at timer mode. GPIO selected Internal input fixed at "0" at RTC mode, STOP mode.

*4 : Maintain previous state at timer mode. Hi-Z/Internal input fixed at "0" at RTC mode, STOP mode.

MB9AA30N Series

■ ELECTRICAL CHARACTERISTICS

1. Absolute Maximum Ratings

Parameter	Symbol	Rating		Unit	Remarks
		Min	Max		
Power supply voltage*1,*2	V_{CC}	$V_{SS} - 0.5$	$V_{SS} + 6.5$	V	
Analog power supply voltage*1,*3	AV_{CC}	$V_{SS} - 0.5$	$V_{SS} + 6.5$	V	
Analog reference voltage*1,*3	AV_{RH}	$V_{SS} - 0.5$	$V_{SS} + 6.5$	V	
LCD input voltage*1,*3	VV4 to VV0	$V_{SS} - 0.5$	$V_{SS} + 6.5$	V	
Input voltage*1	V_I	$V_{SS} - 0.5$	$V_{CC} + 0.5$ ($\leq 6.5V$)	V	
		$V_{SS} - 0.5$	$V_{SS} + 6.5$	V	5V tolerant
Analog pin input voltage*1	V_{IA}	$V_{SS} - 0.5$	$AV_{CC} + 0.5$ ($\leq 6.5V$)	V	
Output voltage*1	V_O	$V_{SS} - 0.5$	$V_{CC} + 0.5$ ($\leq 6.5V$)	V	
"L" level maximum output current*4	I_{OL}	-	10	mA	
"L" level average output current*5	I_{OLAV}	-	4	mA	
"L" level total maximum output current	$\sum I_{OL}$	-	100	mA	
"L" level total average output current*6	$\sum I_{OLAV}$	-	50	mA	
"H" level maximum output current*4	I_{OH}	-	-10	mA	
"H" level average output current*5	I_{OHAV}	-	-4	mA	
"H" level total maximum output current	$\sum I_{OH}$	-	-100	mA	
"H" level total average output current*6	$\sum I_{OHAV}$	-	-50	mA	
Power consumption	P_D	-	400	mW	
Storage temperature	T_{STG}	-55	+150	°C	

*1 : These parameters are based on the condition that $V_{SS} = AV_{SS} = 0V$.

*2 : V_{CC} must not drop below $V_{SS} - 0.5V$.

*3 : Be careful not to exceed $V_{CC} + 0.5V$, for example, when the power is turned on.

*4 : The maximum output current is defined as the value of the peak current flowing through any one of the corresponding pins.

*5 : The average output current is defined as the average current value flowing through any one of the corresponding pins for a 100 ms period.

*6 : The total average output current is defined as the average current value flowing through all of corresponding pins for a 100ms.

<WARNING>

Semiconductor devices may be permanently damaged by application of stress (including, without limitation, voltage, current or temperature) in excess of absolute maximum ratings.

Do not exceed any of these ratings.

2. Recommended Operating Conditions

(V_{SS} = AV_{SS} = 0.0V)

Parameter	Symbol	Conditions	Value		Unit	Remarks	
			Min	Max			
Power supply voltage	V _{CC}	-	1.8	5.5	V	*1	
			2.2	5.5		*2	
LCD input voltage	V _{V4}	-	2.2	V _{CC}	V		
Analog power supply voltage	AV _{CC}	-	1.8	5.5	V	AV _{CC} = V _{CC}	
Analog reference voltage	AV _{RH}	-	2.7	AV _{CC}	V	AV _{CC} ≥ 2.7V	
			AV _{CC}			AV _{CC} < 2.7V	
Smoothing capacitor	C _S	-	1	10	μF	For Regulator *3	
Operating Temperature	FPT-64P-M38, FPT-64P-M39, LCC-64P-M24, FPT-80P-M37, FPT-80P-M40, FPT-100P-M23, FPT-100P-M06, BGA-112P-M04	T _a	-	- 40	+ 85	°C	

*1 : When LCD is not used

*2 : When LCD is used

*3 : See "●C Pin" in "■HANDLING DEVICES" for the smoothing capacitor.

<WARNING>

The recommended operating conditions are required in order to ensure the normal operation of the semiconductor device. All of the device's electrical characteristics are warranted when the device is operated under these conditions.

Any use of semiconductor devices will be under their recommended operating condition.

Operation under any conditions other than these conditions may adversely affect reliability of device and could result in device failure.

No warranty is made with respect to any use, operating conditions or combinations not represented on this data sheet. If you are considering application under any conditions other than listed herein, please contact sales representatives beforehand.

MB9AA30N Series

3. DC Characteristics

(1) Current Rating

($V_{CC} = AV_{CC} = 1.8V$ to $5.5V$, $V_{SS} = AV_{SS} = 0V$, $T_a = -40^{\circ}C$ to $+85^{\circ}C$)

Parameter	Symbol	Pin name	Conditions	Value			Unit	Remarks
				Min	Typ*4	Max		
Power supply current	I_{CC}	VCC	Normal operation (PLL)	-	19	24	mA	CPU : 20MHz, Peripheral : 20MHz, Flash memory 0Wait, FRWTR.RWT = 00, FSYNDN.SD = 000 *1
				-	9.5	12.5	mA	CPU : 20MHz, Peripheral : clock stopped, NOP operation *1
			Normal operation (built-in high-speed CR)	-	4.5	5.5	mA	CPU / Peripheral : 4MHz*2 Flash memory 0Wait FRWTR.RWT = 00 FSYNDN.SD = 000 *1
			Normal operation (sub oscillation)	-	0.25	0.55	mA	CPU / Peripheral : 32kHz, Flash memory 0Wait, FRWTR.RWT = 00, FSYNDN.SD = 000 *1
			Normal operation (built-in low-speed CR)	-	0.3	0.95	mA	CPU / Peripheral : 100kHz, Flash memory 0Wait, FRWTR.RWT = 00, FSYNDN.SD = 000 *1
	I_{CCS}		SLEEP operation (PLL)	-	8	10.5	mA	Peripheral : 20MHz *1
			SLEEP operation (built-in high-speed CR)	-	2	2.5	mA	Peripheral : 4MHz *2 *1
			SLEEP operation (sub oscillation)	-	0.2	0.45	mA	Peripheral : 32kHz *1
			SLEEP operation (built-in low-speed CR)	-	0.25	0.65	mA	Peripheral : 100kHz *1
	I_{CCT}		TIMER mode (sub oscillation)	-	7.5	60	μA	$T_a = +25^{\circ}C$, When LVD is off *1, *3
				-	16	150	μA	$T_a = +85^{\circ}C$, When LVD is off *1, *3

MB9AA30N Series

Parameter	Symbol	Pin name	Conditions	Value			Unit	Remarks	
				Min	Typ*4	Max			
Power supply current	I _{CCR}	VCC	RTC mode	-	1.5	6.5	μA	Ta = + 25°C, When LVD is off *1, *3	
				-	6	89	μA	Ta = + 85°C, When LVD is off *1, *3	
	I _{CCRD}		Deep standby RTC mode	-	1.3	4.5	μA	Ta = + 25°C, When LVD is off *1, *3	
				-	3	32	μA	Ta = + 85°C, When LVD is off *1, *3	
	I _{CCH}		STOP mode	-	0.6	5	μA	Ta = + 25°C, When LVD is off *1	
				-	4.2	87	μA	Ta = + 85°C, When LVD is off *1	
	I _{CCHD}		Deep standby STOP mode	-	0.4	3	μA	Ta = + 25°C, When LVD is off *1	
				-	1.4	30	μA	Ta = + 85°C, When LVD is off *1	
	Low-voltage detection circuit (LVD) power supply current		I _{CCLVD}	For occurrence of reset or for occurrence of interrupt in normal mode operation	-	10	20	μA	When not detected
				For occurrence of reset and for occurrence of interrupt in normal mode operation	-	14	30	μA	
For occurrence of interrupt in low-power mode operation		-		0.3	2	μA	When not detected		

*1: When all ports are fixed.

*2: When setting it to 4MHz by trimming.

*3: When using sub crystal oscillator.

*4: When V_{CC}=3.3V

MB9AA30N Series

(2) Pin Characteristics

($V_{CC} = AV_{CC} = 1.8V$ to $5.5V$, $V_{SS} = AV_{SS} = 0V$, $T_a = -40^{\circ}C$ to $+85^{\circ}C$)

Parameter	Symbol	Pin name	Conditions	Value			Unit	Remarks
				Min	Typ	Max		
"H" level input voltage (hysteresis input)	V_{IHS}	MD0, MD1 PE0, PE2, PE3, P46, P47, P3A, P3B, P3C, P3D, P3E, P3F, INITX	-	$V_{CC} \times 0.8$	-	$V_{CC} + 0.3$	V	
		P0A, P0B, P0C, P4C, P60, P80, P81, P82	-	$V_{CC} \times 0.7$	-	$V_{SS} + 5.5$	V	5V tolerant
		CMOS hysteresis input pins other than the above	-	$V_{CC} \times 0.7$	-	$V_{CC} + 0.3$	V	
"L" level input voltage (hysteresis input)	V_{ILS}	MD0, MD1 PE0, PE2, PE3, P46, P47, INITX	-	$V_{SS} - 0.3$	-	$V_{CC} \times 0.2$	V	
		CMOS hysteresis input pins other than the above	-	$V_{SS} - 0.3$	-	$V_{CC} \times 0.3$	V	
"H" level output voltage	V_{OH}	PXX	$V_{CC} \geq 4.5V$, $I_{OH} = -4mA$ $V_{CC} < 4.5V$, $I_{OH} = -1mA$	$V_{CC} - 0.5$	-	V_{CC}	V	
"L" level output voltage	V_{OL}	PXX	$V_{CC} \geq 4.5V$, $I_{OL} = 4mA$ $V_{CC} < 4.5V$, $I_{OL} = 2mA$	V_{SS}	-	0.4	V	
Input leak current	I_{IL}	-	-	-5	-	+5	μA	
Pull-up resistor value	R_{PU}	Pull-up pin	$V_{CC} \geq 4.5V$	25	50	100	k Ω	
			$V_{CC} < 4.5V$	40	100	400		
Input capacitance	C_{IN}	Other than VCC, VSS, AVCC, AVSS, AVRH	-	-	5	15	pF	

MB9AA30N Series

(3) LCD Characteristics

($V_{CC} = 2.2V$ to $5.5V$, $V_{SS} = 0V$, $T_a = -40^{\circ}C$ to $+85^{\circ}C$)

Parameter	Symbol	Pin name	Conditions	Value			Unit	Remarks
				Min	Typ	Max		
VV0 to VV3 Output voltage (1/4 bias)	V_{VV0}	VV0	When using internal dividing register	0	-	$V_{VV4} \times 5\%$	V	
	V_{VV1}	VV1		$V_{VV4} \times 1/4$ -10%	-	$V_{VV4} \times 1/4$ +10%		
	V_{VV2}	VV2		$V_{VV4} \times 1/2$ -10%	-	$V_{VV4} \times 1/2$ +10%		
	V_{VV3}	VV3		$V_{VV4} \times 3/4$ -10%	-	$V_{VV4} \times 3/4$ +10%		
VV0 to VV3 Output voltage (1/3 bias)	V_{VV0}	VV0	When using internal dividing register	0	-	$V_{VV4} \times 5\%$	V	
	V_{VV1}	VV1		$V_{VV4} \times 1/3$ -10%	-	$V_{VV4} \times 1/3$ +10%		
	V_{VV2}	VV2		$V_{VV4} \times 2/3$ -10%	-	$V_{VV4} \times 2/3$ +10%		
	V_{VV3}	VV3		$V_{VV4} \times 2/3$ -10%	-	$V_{VV4} \times 2/3$ +10%		
VV0 to VV3 Output voltage (1/2 bias)	V_{VV0}	VV0	When using internal dividing register	0	-	$V_{VV4} \times 5\%$	V	
	V_{VV1}	VV1		$V_{VV4} \times 1/2$ -10%	-	$V_{VV4} \times 1/2$ +10%		
	V_{VV2}	VV2		$V_{VV4} \times 1/2$ -10%	-	$V_{VV4} \times 1/2$ +10%		
	V_{VV3}	VV3		$V_{VV4} \times 1/2$ -10%	-	$V_{VV4} \times 1/2$ +10%		
VV4 Active current (1/4 bias)	I_{R100K}	VV4	When using 100 k Ω internal dividing register	-	15	35	μA	
	I_{R10K}	VV4	When using 10 k Ω internal dividing register	-	130	250	μA	
VV4 Active current (1/3 bias)	I_{R100K}	VV4	When using 100 k Ω internal dividing register	-	18	45	μA	
	I_{R10K}	VV4	When using 10 k Ω internal dividing register	-	170	350	μA	
VV4 Active current (1/2 bias)	I_{R100K}	VV4	When using 100 k Ω internal dividing register	-	27	75	μA	
	I_{R10K}	VV4	When using 10 k Ω internal dividing register	-	250	500	μA	
VV4 Static current	I_{off_vv4}	VV4	When LCD stops	-	-	0.5	μA	
VV0 Output Voltage in using external resistor	V_{VV0E}	VV0	$I_{OL}=1mA$	-	-	1.0	V	

MB9AA30N Series

4. AC Characteristics

(1) Main Clock Input Characteristics

($V_{CC} = 1.8V$ to $5.5V$, $V_{SS} = 0V$, $T_a = -40^{\circ}C$ to $+85^{\circ}C$)

Parameter	Symbol	Pin name	Conditions	Value		Unit	Remarks	
				Min	Max			
Input frequency	F_{CH}	X0, X1	$V_{CC} \geq 2.0V$	4	20	MHz	When crystal oscillator is connected	
			$V_{CC} < 2.0V$	4	4	MHz		
			$V_{CC} \geq 4.5V$	4	20	MHz	When using external clock	
			$V_{CC} < 4.5V$	4	16	MHz		
Input clock cycle	t_{CYLH}		$V_{CC} \geq 4.5V$	50	250	ns	When using external clock	
			$V_{CC} < 4.5V$	62.5	250	ns		
Input clock pulse width	-			P_{WH}/t_{CYLH} , P_{WL}/t_{CYLH}	45	55	%	When using external clock
Input clock rising time and falling time	t_{CF} , t_{CR}			-	-	5	ns	When using external clock
	F_{CM}	-	-	-	20	MHz	Master clock	
	F_{CC}	-	-	-	20	MHz	Base clock (HCLK/FCLK)	
	F_{CP0}	-	-	-	20	MHz	APB0 bus clock*2	
	F_{CP1}	-	-	-	20	MHz	APB1 bus clock*2	
	F_{CP2}	-	-	-	20	MHz	APB2 bus clock*2	
Internal operating clock*1 cycle time	t_{CYCC}	-	-	50	-	ns	Base clock (HCLK/FCLK)	
	t_{CYCP0}	-	-	50	-	ns	APB0 bus clock*2	
	t_{CYCP1}	-	-	50	-	ns	APB1 bus clock*2	
	t_{CYCP2}	-	-	50	-	ns	APB2 bus clock*2	

*1: For more information about each internal operating clock, see "Chapter: Clock" in "FM3 Family PERIPHERAL MANUAL".

*2: For about each APB bus which each peripheral is connected to, see "■BLOCK DIAGRAM" in this data sheet.

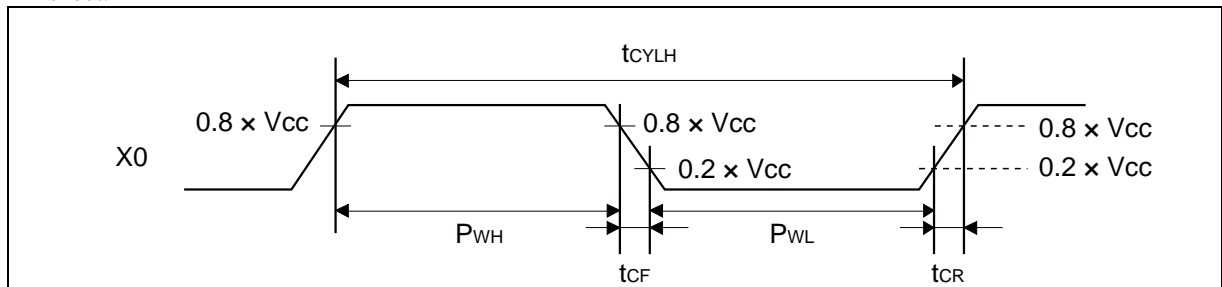

MB9AA30N Series

(2) Sub Clock Input Characteristics

($V_{CC} = 1.8V$ to $5.5V$, $V_{SS} = 0V$, $T_a = -40^{\circ}C$ to $+85^{\circ}C$)

Parameter	Symbol	Pin name	Conditions	Value			Unit	Remarks
				Min	Typ	Max		
Input frequency	F_{CL}	X0A, X1A	-	-	32.768	-	kHz	When crystal oscillator is connected
			-	32	-	100		kHz
Input clock cycle	t_{CYLL}		-	10	-	31.25	μs	When using external clock
Input clock pulse width	-		P_{WH}/t_{CYLL} , P_{WL}/t_{CYLL}	45	-	55	%	When using external clock

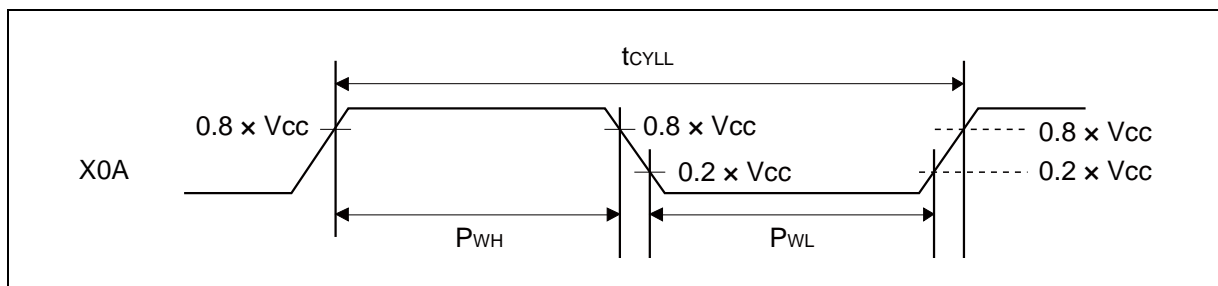

(3) Built-in CR Oscillation Characteristics

- Built-in high-speed CR

($V_{CC} = 1.8V$ to $5.5V$, $V_{SS} = 0V$, $T_a = -40^{\circ}C$ to $+85^{\circ}C$)

Parameter	Symbol	Conditions	Value			Unit	Remarks	
			Min	Typ	Max			
Clock frequency	F_{CRH}	$V_{CC} \geq 2.2V$	$T_a = +25^{\circ}C$	3.92	4	4.08	MHz	When trimming*
			$T_a = -40^{\circ}C$ to $+85^{\circ}C$	3.8	4	4.2		
			$T_a = -40^{\circ}C$ to $+85^{\circ}C$	2.3	-	7.03		When not trimming
		$V_{CC} < 2.2V$	$T_a = +25^{\circ}C$	3.4	4	4.6	MHz	When trimming*
			$T_a = -40^{\circ}C$ to $+85^{\circ}C$	3.16	4	4.84		
			$T_a = -40^{\circ}C$ to $+85^{\circ}C$	2.3	-	7.03		When not trimming

*: In the case of using the values in CR trimming area of Flash memory at shipment for frequency trimming.

- Built-in low-speed CR

($V_{CC} = 1.8V$ to $5.5V$, $V_{SS} = 0V$, $T_a = -40^{\circ}C$ to $+85^{\circ}C$)

Parameter	Symbol	Conditions	Value			Unit	Remarks
			Min	Typ	Max		
Clock frequency	F_{CRL}	-	50	100	150	kHz	

MB9AA30N Series

(4-1) Operating Conditions of Main PLL (In the case of using main clock for input of PLL)

($V_{CC} = 1.8V$ to $5.5V$, $V_{SS} = 0V$, $T_a = -40^{\circ}C$ to $+85^{\circ}C$)

Parameter	Symbol	Value			Unit	Remarks
		Min	Typ	Max		
PLL oscillation stabilization wait time* ¹ (LOCK UP time)	t_{LOCK}	200	-	-	μs	
PLL input clock frequency	F_{PLLI}	4	-	20	MHz	
PLL multiplication rate	-	1	-	5	multiplier	
PLL macro oscillation clock frequency	F_{PLLO}	10	-	20	MHz	
Main PLL clock frequency* ²	F_{CLKPLL}	-	-	20	MHz	

*1: Time from when the PLL starts operating until the oscillation stabilizes.

*2: For more information about Main PLL clock (CLKPLL), see "Chapter: Clock" in "FM3 Family PERIPHERAL MANUAL".

(4-2) Operating Conditions of Main PLL (In the case of using the built-in high-speed CR for the input clock of the main PLL)

($V_{CC} = 2.2V$ to $5.5V$, $V_{SS} = 0V$, $T_a = -40^{\circ}C$ to $+85^{\circ}C$)

Parameter	Symbol	Value			Unit	Remarks
		Min	Typ	Max		
PLL oscillation stabilization wait time* ¹ (LOCK UP time)	t_{LOCK}	200	-	-	μs	
PLL input clock frequency	F_{PLLI}	3.8	4	4.2	MHz	
PLL multiplication rate	-	3	-	4	multiplier	
PLL macro oscillation clock frequency	F_{PLLO}	11.4	-	16.8	MHz	
Main PLL clock frequency* ²	F_{CLKPLL}	-	-	16.8	MHz	

*1: Time from when the PLL starts operating until the oscillation stabilizes.

*2: For more information about Main PLL clock (CLKPLL), see "Chapter: Clock" in "FM3 Family PERIPHERAL MANUAL".

Note: Make sure to input to the main PLL source clock, the high-speed CR clock (CLKHC) that the frequency has been trimmed.

(5) Reset Input Characteristics

($V_{CC} = 1.8V$ to $5.5V$, $V_{SS} = 0V$, $T_a = -40^{\circ}C$ to $+85^{\circ}C$)

Parameter	Symbol	Pin name	Conditions	Value		Unit	Remarks
				Min	Max		
Reset input time	t_{INITX}	INITX	-	500	-	ns	
				1.5	-	ms	When RTC mode or STOP mode
				1.5	-	ms	When deep standby mode

(6) Power-on Reset Timing

($V_{CC} = 1.8V$ to $5.5V$, $V_{SS} = 0V$, $T_a = -40^{\circ}C$ to $+85^{\circ}C$)

Parameter	Symbol	Pin name	Value			Unit	Remarks
			Min	Typ	Max		
Power supply rising time	dV/dt	VCC	0.1	-	-	V/ms	
Power supply shut down time	Toff		1	-	-	ms	
Reset release voltage	Vdeth		1.44	1.60	1.76	V	When voltage rises
Reset detection voltage	Vdetl		1.39	1.55	1.71	V	When voltage drops
Reset release delay time	Tond		-	-	10	ms	$dV/dt \geq 0.1mV/\mu s$
Reset detection delay time	Toffd		-	-	0.4	ms	$dV/dt \geq -0.04mV/\mu s$

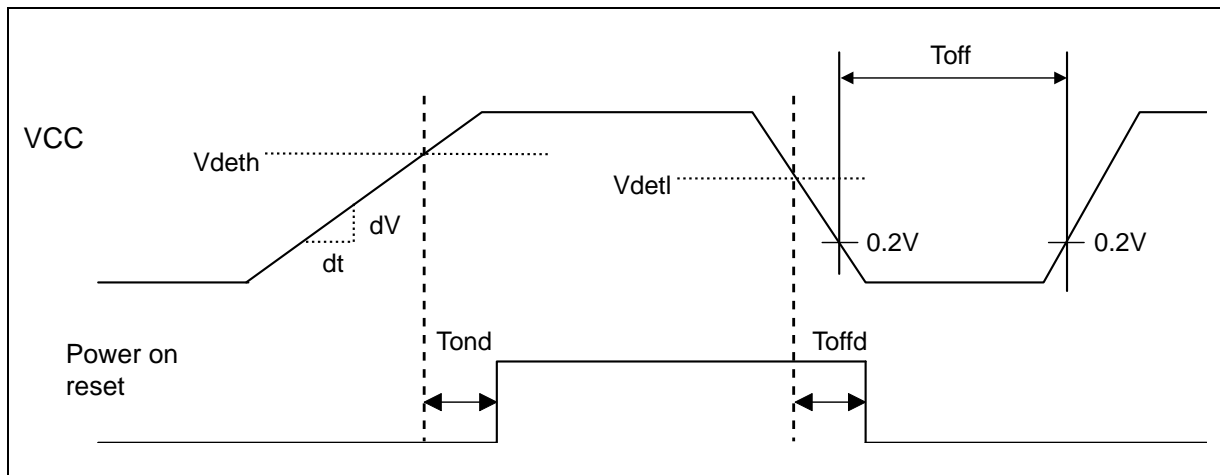

MB9AA30N Series

(7) Base Timer Input Timing

- Timer input timing

($V_{CC} = 1.8V$ to $5.5V$, $V_{SS} = 0V$, $T_a = -40^{\circ}C$ to $+85^{\circ}C$)

Parameter	Symbol	Pin name	Conditions	Value		Unit	Remarks
				Min	Max		
Input pulse width	t_{TIWH} , t_{TIWL}	TIOAn/TIOBn (when using as ECK, TIN)	-	$2t_{CYCP}$	-	ns	

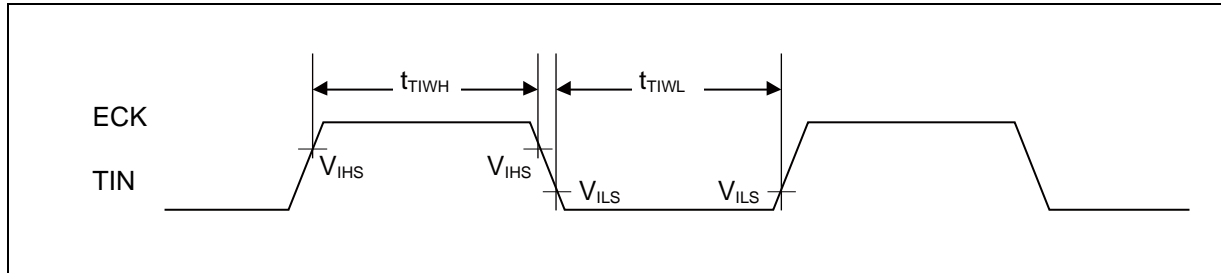

- Trigger input timing

($V_{CC} = 1.8V$ to $5.5V$, $V_{SS} = 0V$, $T_a = -40^{\circ}C$ to $+85^{\circ}C$)

Parameter	Symbol	Pin name	Conditions	Value		Unit	Remarks
				Min	Max		
Input pulse width	t_{TRGH} , t_{TRGL}	TIOAn/TIOBn (when using as TGIN)	-	$2t_{CYCP}$	-	ns	

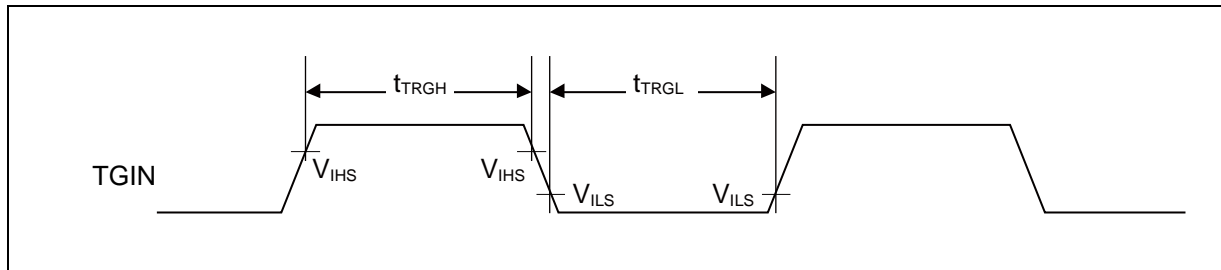

Note: t_{CYCP} indicates the APB bus clock cycle time. About the APB bus number which the base timer is connected to, see "■BLOCK DIAGRAM" in this data sheet.

(8) UART Timing

- Synchronous serial (SPI = 0, SCINV = 0)

($V_{CC} = 1.8V$ to $5.5V$, $V_{SS} = 0V$, $T_a = -40^{\circ}C$ to $+85^{\circ}C$)

Parameter	Symbol	Pin name	Conditions	$V_{CC} < 2.7V$		$2.7V \leq V_{CC} < 4.5V$		$V_{CC} \geq 4.5V$		Unit
				Min	Max	Min	Max	Min	Max	
Serial clock cycle time	t_{SCYC}	SCK _X	Internal shift clock operation	$4t_{CYCP}$	-	$4t_{CYCP}$	-	$4t_{CYCP}$	-	ns
SCK ↓ → SOT delay time	t_{SLOVI}	SCK _X , SOT _X		-40	+40	-30	+30	-20	+20	ns
SIN → SCK ↑ setup time	t_{IVSHI}	SCK _X , SIN _X		75	-	50	-	30	-	ns
SCK ↑ → SIN hold time	t_{SHIXI}	SCK _X , SIN _X		0	-	0	-	0	-	ns
Serial clock "L" pulse width	t_{LSLH}	SCK _X	External shift clock operation	$2t_{CYCP} - 10$	-	$2t_{CYCP} - 10$	-	$2t_{CYCP} - 10$	-	ns
Serial clock "H" pulse width	t_{HSL}	SCK _X		$t_{CYCP} + 10$	-	$t_{CYCP} + 10$	-	$t_{CYCP} + 10$	-	ns
SCK ↓ → SOT delay time	t_{SLOVE}	SCK _X , SOT _X		-	75	-	50	-	30	ns
SIN → SCK ↑ setup time	t_{IVSHE}	SCK _X , SIN _X		10	-	10	-	10	-	ns
SCK ↑ → SIN hold time	t_{SHIXE}	SCK _X , SIN _X		20	-	20	-	20	-	ns
SCK falling time	tF	SCK _X		-	5	-	5	-	5	ns
SCK rising time	tR	SCK _X		-	5	-	5	-	5	ns

- Notes:
- The above characteristics apply to CLK synchronous mode.
 - t_{CYCP} indicates the APB bus clock cycle time.
About the APB bus number which UART is connected to, see "■BLOCK DIAGRAM" in this data sheet.
 - These characteristics only guarantee the same relocate port number.
For example, the combination of SCLK_{X_0} and SOT_{X_1} is not guaranteed.
 - When the external load capacitance $C_L = 50pF$.

MB9AA30N Series

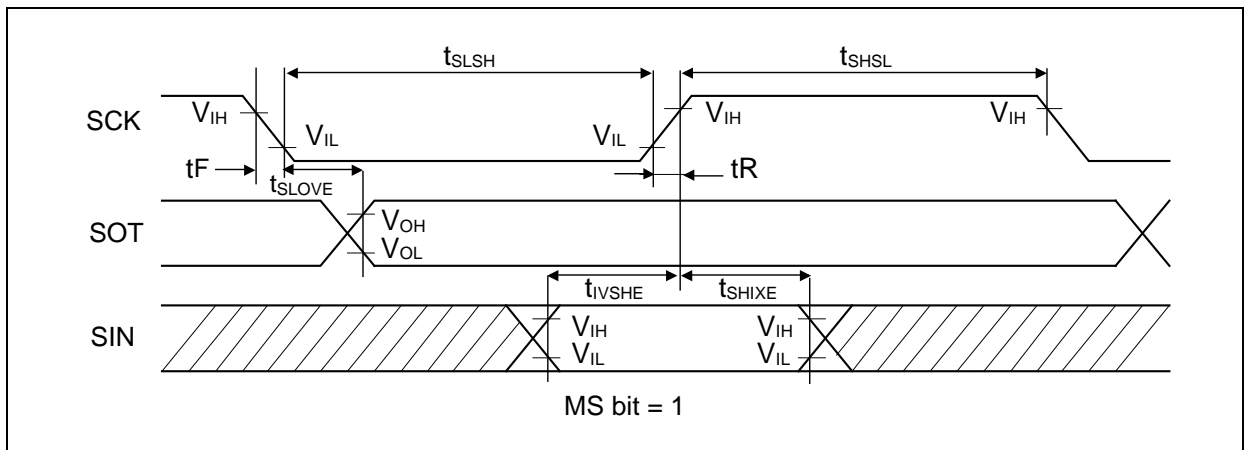
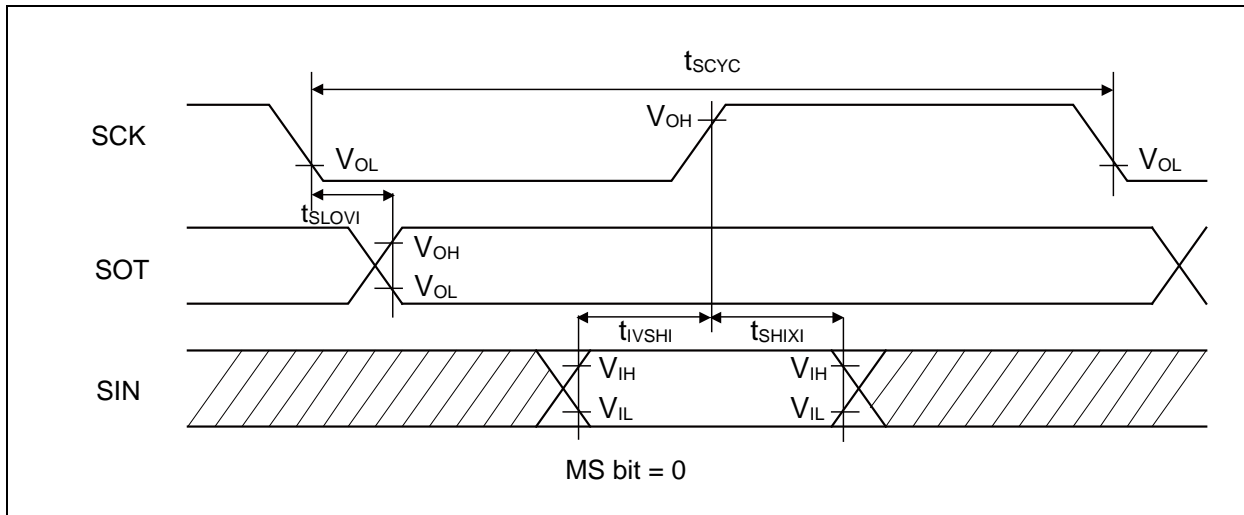

MB9AA30N Series

- Synchronous serial (SPI = 0, SCINV = 1)

($V_{CC} = 1.8V$ to $5.5V$, $V_{SS} = 0V$, $T_a = -40^{\circ}C$ to $+85^{\circ}C$)

Parameter	Symbol	Pin name	Conditions	$V_{CC} < 2.7V$		$2.7V \leq V_{CC} < 4.5V$		$V_{CC} \geq 4.5V$		Unit
				Min	Max	Min	Max	Min	Max	
Serial clock cycle time	t_{SCYC}	SCK _x	Internal shift clock operation	$4t_{CYCP}$	-	$4t_{CYCP}$	-	$4t_{CYCP}$	-	ns
SCK \uparrow \rightarrow SOT delay time	t_{SHOVI}	SCK _x , SOT _x		-40	+40	-30	+30	-20	+20	ns
SIN \rightarrow SCK \downarrow setup time	t_{IVSLI}	SCK _x , SIN _x		75	-	50	-	30	-	ns
SCK \downarrow \rightarrow SIN hold time	t_{SLIXI}	SCK _x , SIN _x		0	-	0	-	0	-	ns
Serial clock "L" pulse width	t_{SLSH}	SCK _x	External shift clock operation	$2t_{CYCP} - 10$	-	$2t_{CYCP} - 10$	-	$2t_{CYCP} - 10$	-	ns
Serial clock "H" pulse width	t_{SHSL}	SCK _x		$t_{CYCP} + 10$	-	$t_{CYCP} + 10$	-	$t_{CYCP} + 10$	-	ns
SCK \uparrow \rightarrow SOT delay time	t_{SHOVE}	SCK _x , SOT _x		-	75	-	50	-	30	ns
SIN \rightarrow SCK \downarrow setup time	t_{IVSLE}	SCK _x , SIN _x		10	-	10	-	10	-	ns
SCK \downarrow \rightarrow SIN hold time	t_{SLIXE}	SCK _x , SIN _x		20	-	20	-	20	-	ns
SCK falling time	tF	SCK _x		-	5	-	5	-	5	ns
SCK rising time	tR	SCK _x		-	5	-	5	-	5	ns

- Notes:
- The above characteristics apply to CLK synchronous mode.
 - t_{CYCP} indicates the APB bus clock cycle time.
About the APB bus number which UART is connected to, see "■BLOCK DIAGRAM" in this data sheet.
 - These characteristics only guarantee the same relocate port number.
For example, the combination of SCLK_{x_0} and SOT_{x_1} is not guaranteed.
 - When the external load capacitance $C_L = 50pF$.

MB9AA30N Series

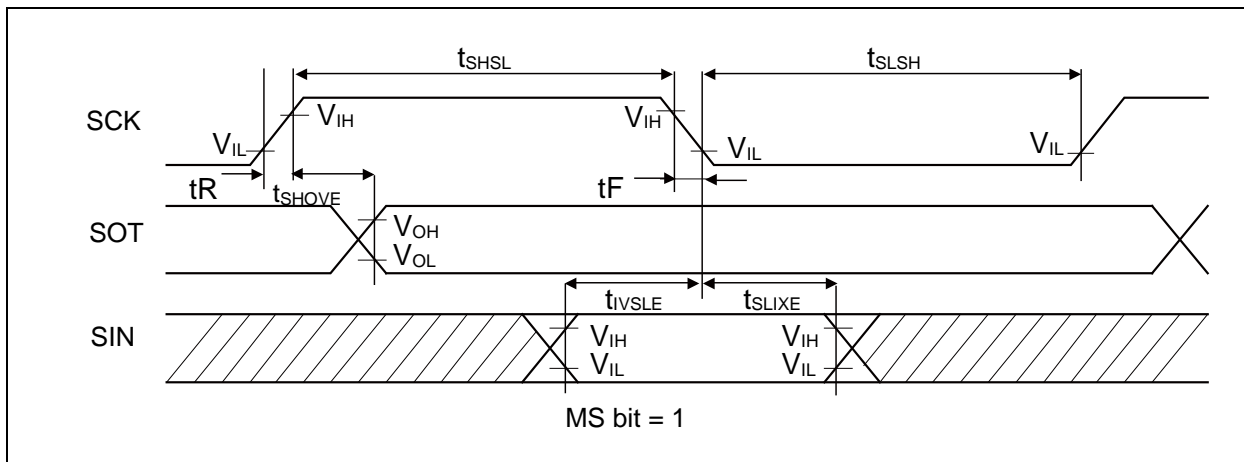
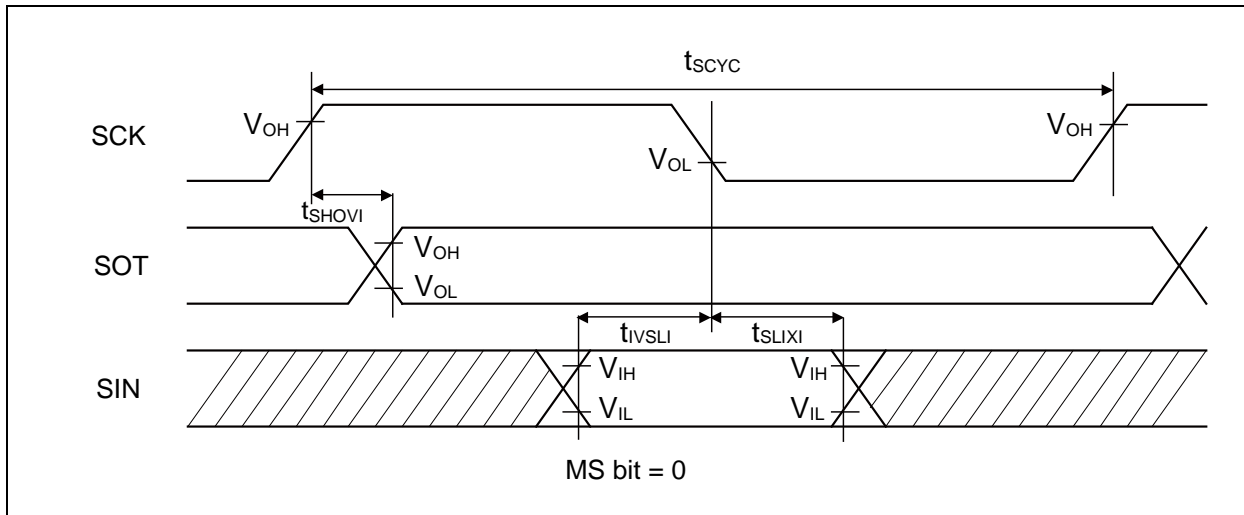

MB9AA30N Series

- Synchronous serial (SPI = 1, SCINV = 0)

($V_{CC} = 1.8V$ to $5.5V$, $V_{SS} = 0V$, $T_a = -40^{\circ}C$ to $+85^{\circ}C$)

Parameter	Symbol	Pin name	Conditions	$V_{CC} < 2.7V$		$2.7V \leq V_{CC} < 4.5V$		$V_{CC} \geq 4.5V$		Unit
				Min	Max	Min	Max	Min	Max	
Serial clock cycle time	t_{SCYC}	SCK _X	Internal shift clock operation	$4t_{CYCP}$	-	$4t_{CYCP}$	-	$4t_{CYCP}$	-	ns
SCK \uparrow \rightarrow SOT delay time	t_{SHOVI}	SCK _X , SOT _X		-40	+40	-30	+30	-20	+20	ns
SIN \rightarrow SCK \downarrow setup time	t_{IVSLI}	SCK _X , SIN _X		75	-	50	-	30	-	ns
SCK \downarrow \rightarrow SIN hold time	t_{SLIXI}	SCK _X , SIN _X		0	-	0	-	0	-	ns
SOT \rightarrow SCK \downarrow delay time	t_{SOVLI}	SCK _X , SOT _X		$2t_{CYCP} - 30$	-	$2t_{CYCP} - 30$	-	$2t_{CYCP} - 30$	-	ns
Serial clock "L" pulse width	t_{SLSH}	SCK _X	External shift clock operation	$2t_{CYCP} - 10$	-	$2t_{CYCP} - 10$	-	$2t_{CYCP} - 10$	-	ns
Serial clock "H" pulse width	t_{SHSL}	SCK _X		$t_{CYCP} + 10$	-	$t_{CYCP} + 10$	-	$t_{CYCP} + 10$	-	ns
SCK \uparrow \rightarrow SOT delay time	t_{SHOVE}	SCK _X , SOT _X		-	75	-	50	-	30	ns
SIN \rightarrow SCK \downarrow setup time	t_{IVSLE}	SCK _X , SIN _X		10	-	10	-	10	-	ns
SCK \downarrow \rightarrow SIN hold time	t_{SLIXE}	SCK _X , SIN _X		20	-	20	-	20	-	ns
SCK falling time	tF	SCK _X		-	5	-	5	-	5	ns
SCK rising time	tR	SCK _X		-	5	-	5	-	5	ns

- Notes:
- The above characteristics apply to CLK synchronous mode.
 - t_{CYCP} indicates the APB bus clock cycle time.
About the APB bus number which UART is connected to, see "■BLOCK DIAGRAM" in this data sheet.
 - These characteristics only guarantee the same relocate port number.
For example, the combination of SCLK_X_0 and SOT_X_1 is not guaranteed.
 - When the external load capacitance $C_L = 50pF$.

MB9AA30N Series

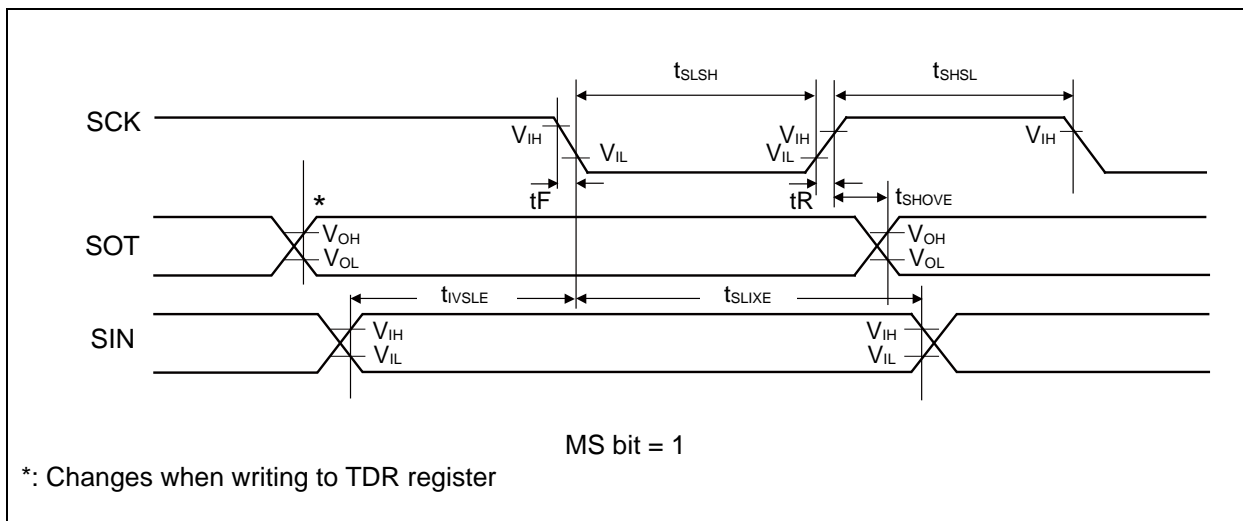
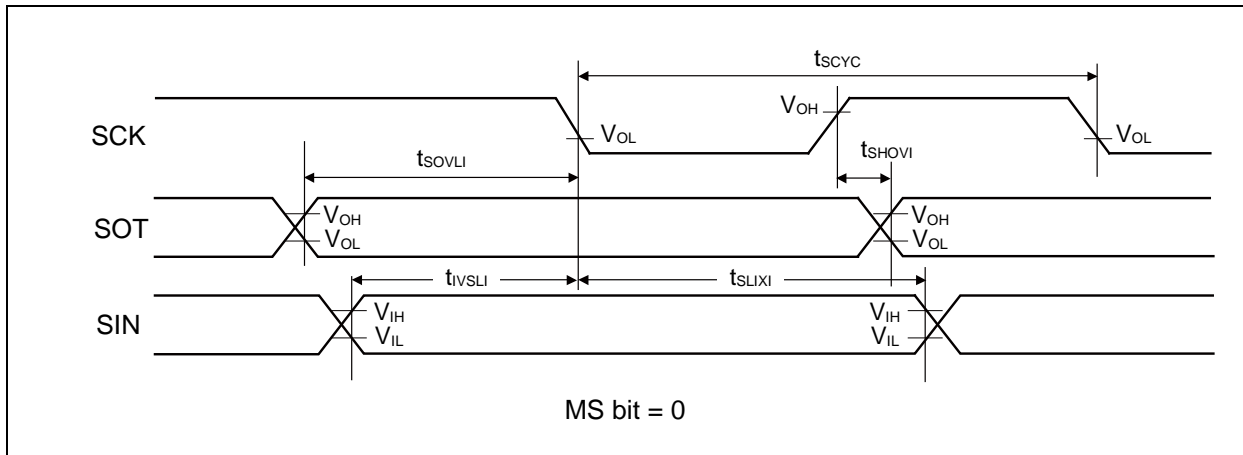

MB9AA30N Series

- Synchronous serial (SPI = 1, SCINV = 1)

($V_{CC} = 1.8V$ to $5.5V$, $V_{SS} = 0V$, $T_a = -40^{\circ}C$ to $+85^{\circ}C$)

Parameter	Symbol	Pin name	Conditions	$V_{CC} < 2.7V$		$2.7V \leq V_{CC} < 4.5V$		$V_{CC} \geq 4.5V$		Unit
				Min	Max	Min	Max	Min	Max	
Serial clock cycle time	t_{SCYC}	SCK _X	Internal shift clock operation	$4t_{CYCP}$	-	$4t_{CYCP}$	-	$4t_{CYCP}$	-	ns
SCK ↓ → SOT delay time	t_{SLOVI}	SCK _X , SOT _X		-40	+40	-30	+30	-20	+20	ns
SIN → SCK ↑ setup time	t_{IVSHI}	SCK _X , SIN _X		75	-	50	-	30	-	ns
SCK ↑ → SIN hold time	t_{SHIXI}	SCK _X , SIN _X		0	-	0	-	0	-	ns
SOT → SCK ↑ delay time	t_{SOVHI}	SCK _X , SOT _X		$2t_{CYCP} - 30$	-	$2t_{CYCP} - 30$	-	$2t_{CYCP} - 30$	-	ns
Serial clock "L" pulse width	t_{LSLH}	SCK _X	External shift clock operation	$2t_{CYCP} - 10$	-	$2t_{CYCP} - 10$	-	$2t_{CYCP} - 10$	-	ns
Serial clock "H" pulse width	t_{HSL}	SCK _X		$t_{CYCP} + 10$	-	$t_{CYCP} + 10$	-	$t_{CYCP} + 10$	-	ns
SCK ↓ → SOT delay time	t_{SLOVE}	SCK _X , SOT _X		-	75	-	50	-	30	ns
SIN → SCK ↑ setup time	t_{IVSHE}	SCK _X , SIN _X		10	-	10	-	10	-	ns
SCK ↑ → SIN hold time	t_{SHIXE}	SCK _X , SIN _X		20	-	20	-	20	-	ns
SCK falling time	tF	SCK _X		-	5	-	5	-	5	ns
SCK rising time	tR	SCK _X		-	5	-	5	-	5	ns

- Notes:
- The above characteristics apply to CLK synchronous mode.
 - t_{CYCP} indicates the APB bus clock cycle time.
About the APB bus number which UART is connected to, see "■BLOCK DIAGRAM" in this data sheet.
 - These characteristics only guarantee the same relocate port number.
For example, the combination of SCLK_X_0 and SOT_X_1 is not guaranteed.
 - When the external load capacitance $C_L = 50pF$.

MB9AA30N Series

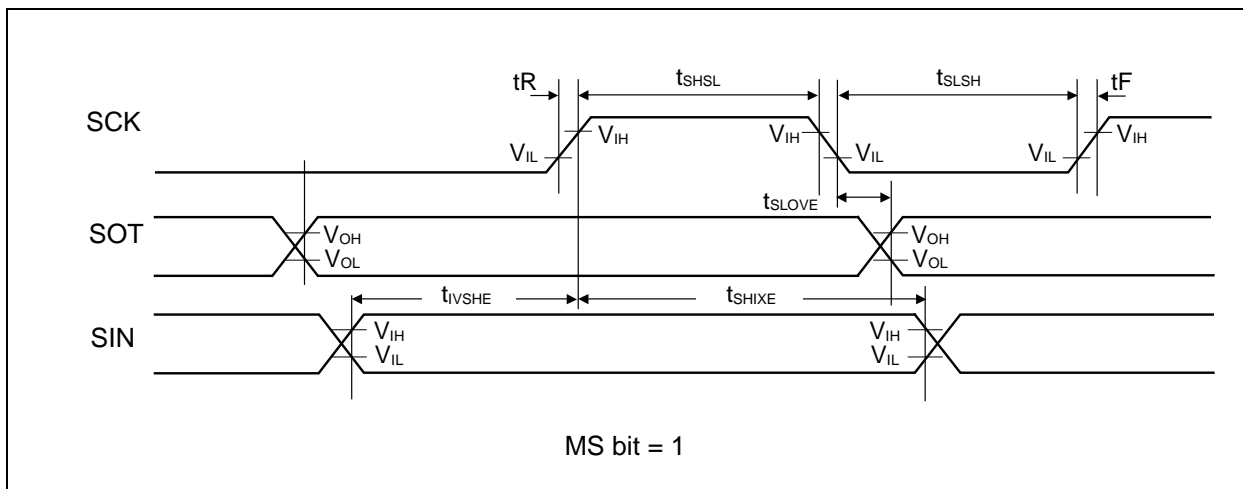
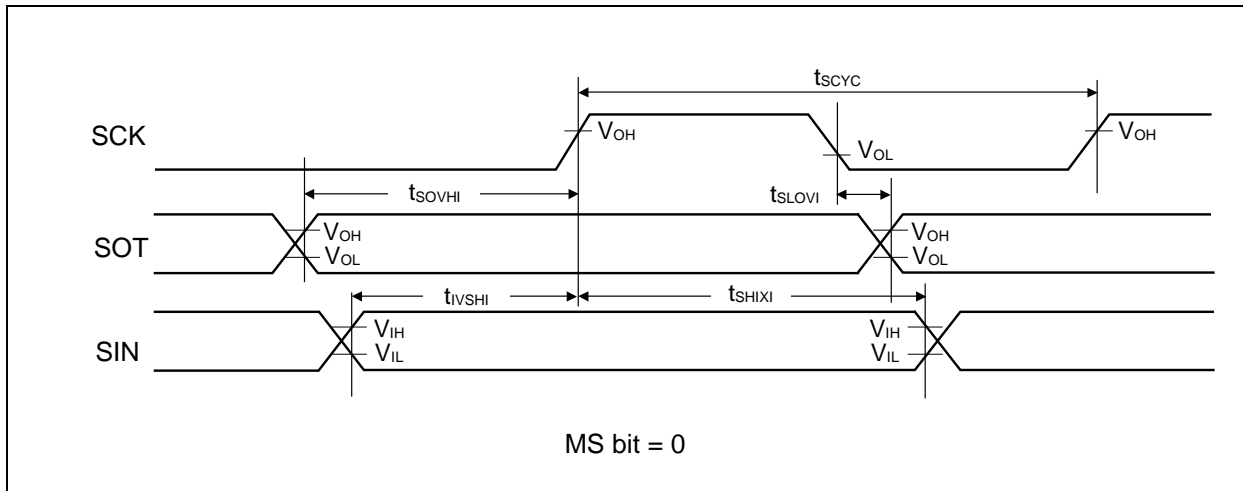

- External clock (EXT = 1) : asynchronous only

($V_{CC} = 1.8V$ to $5.5V$, $V_{SS} = 0V$, $T_a = -40^{\circ}C$ to $+85^{\circ}C$)

Parameter	Symbol	Conditions	Value		Unit	Remarks
			Min	Max		
Serial clock "L" pulse width	t_{SLSH}	$C_L = 50pF$	$t_{CYCP} + 10$	-	ns	
Serial clock "H" pulse width	t_{SHSL}		$t_{CYCP} + 10$	-	ns	
SCK falling time	t_F		-	5	ns	
SCK rising time	t_R		-	5	ns	

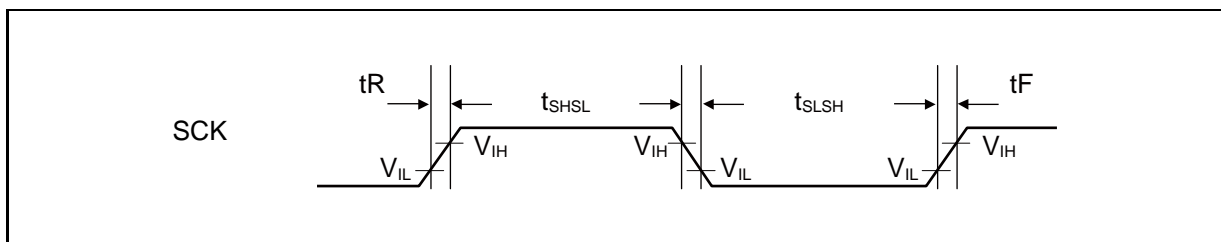

(9) External Input Timing

($V_{CC} = 1.8V$ to $5.5V$, $V_{SS} = 0V$, $T_a = -40^{\circ}C$ to $+85^{\circ}C$)

Parameter	Symbol	Pin name	Conditions	Value		Unit	Remarks
				Min	Max		
Input pulse width	t_{INH} , t_{INL}	ADTG	-	$2t_{CYCP}^{*1}$	-	ns	A/D converter trigger input
		FRCKx					Free-run timer input clock
		ICxx	-	$2t_{CYCP}^{*1}$	-	ns	Input capture
		DTTIXX					Waveform generator
		IGTRG					PPG IGBT mode
		INT00 to INT15, NMIX	-	$2t_{CYCP} + 100^{*1}$	-	ns	External interrupt, NMI
				500^{*2}	-	ns	
WKUPx	-	500^{*3}	-	ns	Deep standby wake up		

*1 : t_{CYCP} indicates the APB bus clock cycle time except stop when in stop mode, etc.

About the APB bus number which the A/D converter, Multifunction Timer, PPG, External interrupt, Deep standby mode Controller are connected to, see "■BLOCK DIAGRAM" in this data sheet.

*2 : When in stop mode, in timer mode.

*3 : When in deep standby STOP mode, in deep standby RTC mode.

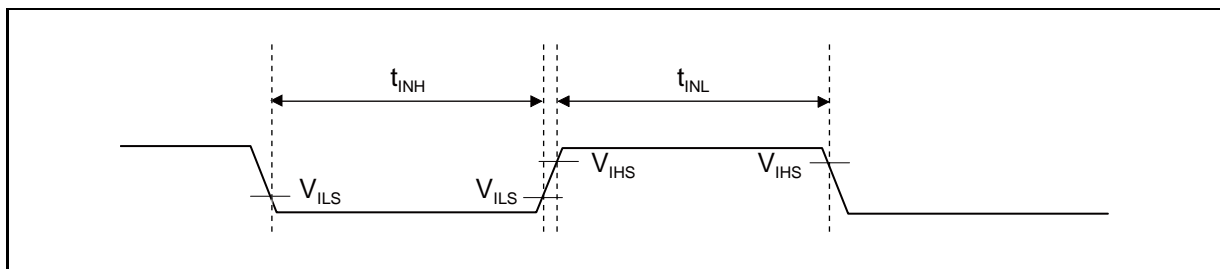

MB9AA30N Series

(10) I²C Timing

(V_{CC} = 1.8V to 5.5V, V_{SS} = 0V, Ta = -40°C to +85°C)

Parameter	Symbol	Conditions	Typical mode		High-speed mode		Unit	Remarks
			Min	Max	Min	Max		
SCL clock frequency	F _{SCL}		0	100	0	400	kHz	
(Repeated) START condition hold time SDA ↓ → SCL ↓	t _{HDSTA}	C _L = 50pF, R = (V _p /I _{OL})* ¹	4.0	-	0.6	-	μs	
SCL clock "L" width	t _{LOW}		4.7	-	1.3	-	μs	
SCL clock "H" width	t _{HIGH}		4.0	-	0.6	-	μs	
(Repeated) START condition setup time SCL ↑ → SDA ↓	t _{SUSTA}		4.7	-	0.6	-	μs	
Data hold time SCL ↓ → SDA ↓ ↑	t _{HDDAT}		0	3.45* ²	0	0.9* ³	μs	
Data setup time SDA ↓ ↑ → SCL ↑	t _{SUDAT}		250	-	100	-	ns	
STOP condition setup time SCL ↑ → SDA ↑	t _{SUSTO}		4.0	-	0.6	-	μs	
Bus free time between "STOP condition" and "START condition"	t _{BUF}		4.7	-	1.3	-	μs	
Noise filter	t _{SP}	-	2 t _{CYCP} * ⁴	-	2 t _{CYCP} * ⁴	-	ns	

*1 : R and C_L represent the pull-up resistor and load capacitance of the SCL and SDA lines, respectively. V_p indicates the power supply voltage of the pull-up resistor and I_{OL} indicates V_{OL} guaranteed current.

*2 : The maximum t_{HDDAT} must satisfy that it does not extend at least "L" period (t_{LOW}) of device's SCL signal.

*3 : A high-speed mode I²C bus device can be used on a standard mode I²C bus system as long as the device satisfies the requirement of "t_{SUDAT} ≥ 250 ns".

*4 : t_{CYCP} is the APB bus clock cycle time. About the APB bus number which I²C is connected to, see "■BLOCK DIAGRAM" in this data sheet. To use I²C, set the peripheral bus clock at 8 MHz or more.

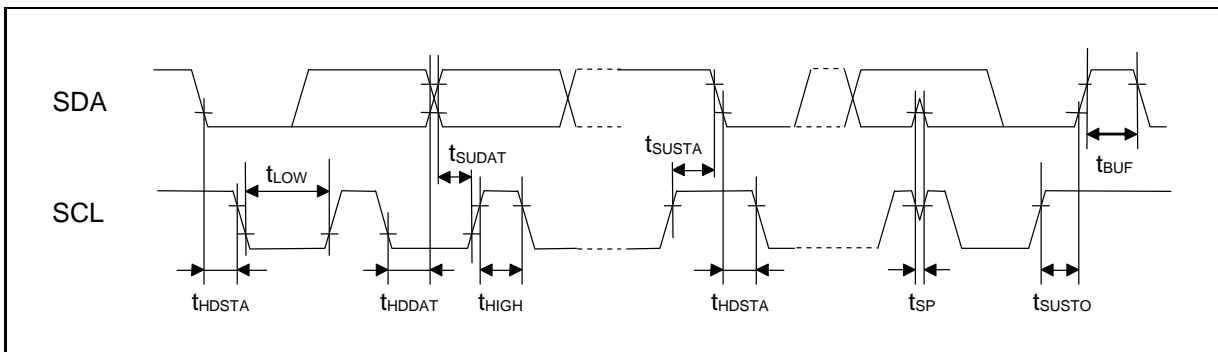

(11) JTAG Timing

($V_{CC} = 1.8V$ to $5.5V$, $V_{SS} = 0V$, $T_a = -40^{\circ}C$ to $+85^{\circ}C$)

Parameter	Symbol	Pin name	Conditions	Value		Unit	Remarks
				Min	Max		
TMS,TDI setup time	t_{JTAGS}	TCK, TMS, TDI	$V_{CC} \geq 4.5V$	15	-	ns	
			$V_{CC} < 4.5V$				
TMS,TDI hold time	t_{JTAGH}	TCK, TMS, TDI	$V_{CC} \geq 4.5V$	15	-	ns	
			$V_{CC} < 4.5V$				
TDO delay time	t_{JTAGD}	TCK, TDO	$V_{CC} \geq 4.5V$	-	30	ns	
			$2.7V \leq V_{CC} < 4.5V$	-	45		
			$V_{CC} < 2.7V$	-	60		

Note: When the external load capacitance $C_L = 50pF$.

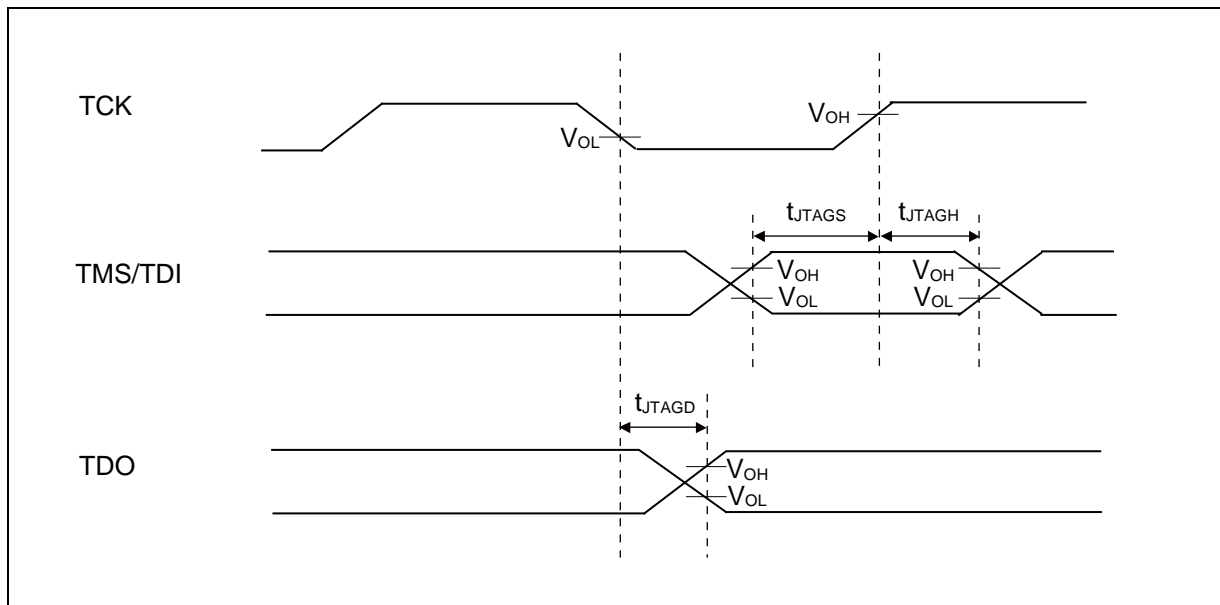

MB9AA30N Series

5. 12-bit A/D Converter

(1) Electrical Characteristics for the A/D Converter

($V_{CC} = AV_{CC} = 1.8V$ to $5.5V$, $V_{SS} = AV_{SS} = 0V$, $T_a = -40^{\circ}C$ to $+85^{\circ}C$)

Parameter	Symbol	Pin name	Value			Unit	Remarks
			Min	Typ	Max		
Resolution	-	-	-	-	12	bit	
Non linearity error	-	-	- 3.0	-	+ 3.0	LSB	$AV_{CC} \geq 2.7V$
			- 4.0	-	+ 4.0	LSB	$AV_{CC} < 2.7V$
Differential linearity error	-	-	- 1.9	-	+ 1.9	LSB	$AV_{CC} \geq 2.7V$
			- 2.9	-	+ 2.9	LSB	$AV_{CC} < 2.7V$
Zero transition voltage	V_{OT}	AN00 to AN15	- 20	-	+ 20	mV	
Full-scale transition voltage	V_{FST}	AN00 to AN15	AVRH-20	-	AVRH+20	mV	
Conversion time	-	-	1.0* ¹	-	-	μs	$AV_{CC} \geq 2.7V$
Sampling time	T_s	-	*2	-	10	μs	
Compare clock cycle* ³	T_{cck}	-	50	-	1000	ns	$AV_{CC} \geq 2.7V$
			200				$AV_{CC} < 2.7V$
Period of operation enable state transitions	T_{stt}	-	1.0	-	-	μs	
Power supply current (analog + digital)	-	AVCC	-	1.4	2.5	mA	A/D operation
			-	0.1	0.35	μA	A/D stop
Reference power supply current (between AVRH and AVSS)	-	AVRH	-	0.5	1.5	mA	A/D operation AVRH=5.5V
			-	0.1	0.3	μA	A/D stop
Analog input capacity	C_{AIN}	-	-	-	15	pF	
Analog input resistor	R_{AIN}	-	-	-	0.9	k Ω	$AV_{CC} \geq 4.5V$
					1.6		$2.7V \leq AV_{CC} < 4.5V$
					4.0		$AV_{CC} < 2.7V$
Interchannel disparity	-	-	-	-	4	LSB	
Analog port input current	-	AN00 to AN15	-	-	0.3	μA	
Analog input voltage	-	AN00 to AN15	AVSS	-	AVRH	V	
Reference voltage	-	AVRH	2.7	-	AVCC	V	$AV_{CC} \geq 2.7V$
			AVCC				$AV_{CC} < 2.7V$

*1: The conversion time is the value of sampling time (T_s) + compare time (T_c).

The condition of the minimum conversion time is, the value of sampling time: 300ns, the value of compare time: 700ns. ($AV_{CC} \geq 2.7V$)

Ensure that it satisfies the value of the sampling time (T_s) and compare clock cycle (T_{cck}).

For setting*⁴ of the sampling time and compare clock cycle, see "Chapter: A/D Converter" in "FM3 Family PERIPHERAL MANUAL Analog Macro Part".

*2: A necessary sampling time changes by external impedance.

Ensure to set the sampling time to satisfy (Equation 1).

*3: The compare time (T_c) is the value of (Equation 2).

*4: The register setting of the A/D Converter is reflected by the timing of the APB bus clock.

The sampling clock and compare clock are set with the base clock (HCLK).

About the APB bus number which the A/D Converter is connected to, see "■BLOCK DIAGRAM" in this data sheet.

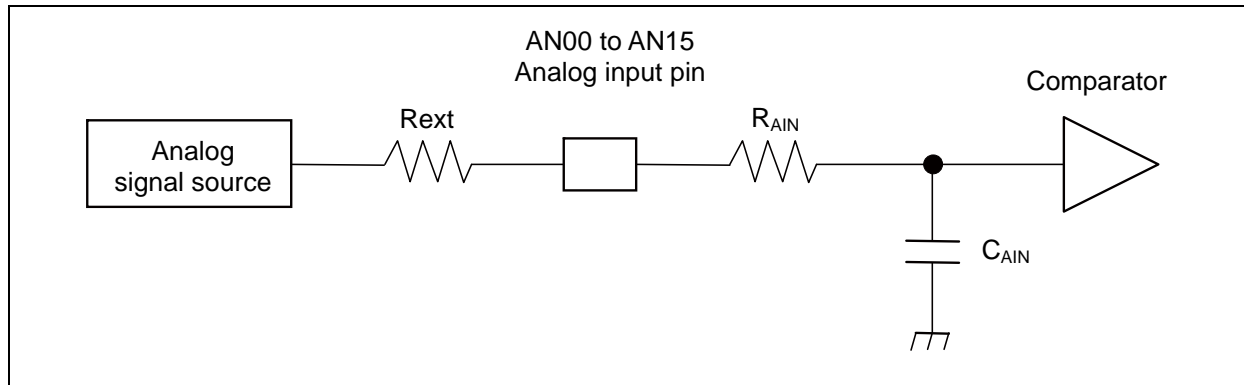

(Equation 1) $T_s \geq (R_{AIN} + R_{ext}) \times C_{AIN} \times 9$

T_s : Sampling time

R_{AIN} : input resistor of A/D = 0.9k Ω at $4.5 \leq AVCC \leq 5.5$

input resistor of A/D = 1.6k Ω at $2.7 \leq AVCC < 4.5$

input resistor of A/D = 4.0k Ω at $1.8 \leq AVCC < 2.7$

C_{AIN} : input capacity of A/D = 15pF at $1.8 \leq AVCC \leq 5.5$

R_{ext} : Output impedance of external circuit

(Equation 2) $T_c = T_{cck} \times 14$

T_c : Compare time

T_{cck} : Compare clock cycle

MB9AA30N Series

• Definition of 12-bit A/D Converter Terms

- Resolution : Analog variation that is recognized by an A/D converter.
- Linearity error : Deviation of the line between the zero-transition point (0b000000000000 \longleftrightarrow 0b000000000001) and the full-scale transition point (0b111111111110 \longleftrightarrow 0b111111111111) from the actual conversion characteristics.
- Differential linearity error : Deviation from the ideal value of the input voltage that is required to change the output code by 1 LSB.

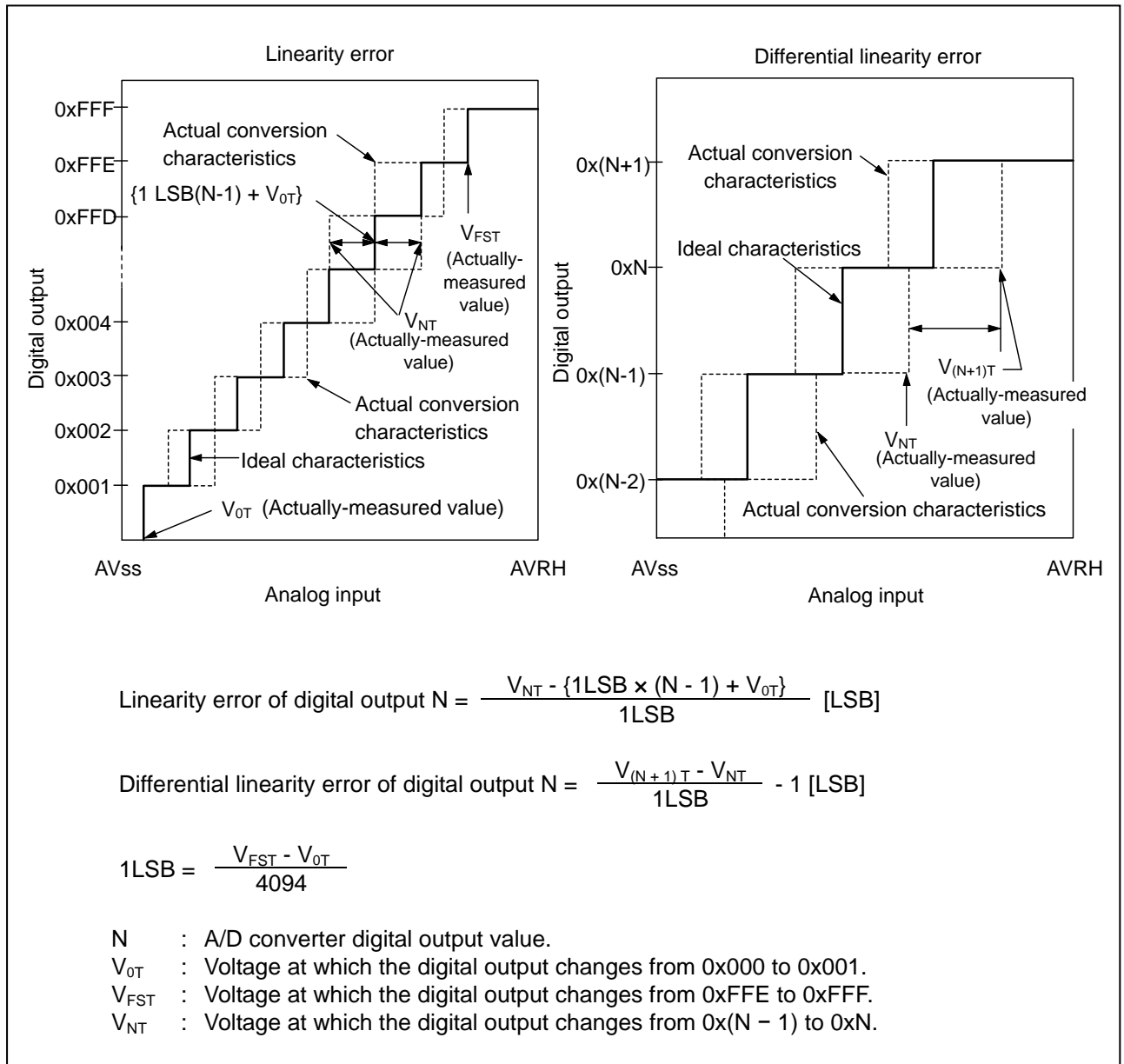

6. 10-bit D/A Converter

- Electrical Characteristics for the D/A Converter

($V_{CC} = AV_{CC} = 1.8V$ to $5.5V$, $V_{SS} = AV_{SS} = 0V$, $T_a = -40^{\circ}C$ to $+85^{\circ}C$)

Parameter	Symbol	Pin name	Value			Unit	Remarks
			Min	Typ	Max		
Resolution	-	DAx	-	-	10	bit	
Conversion time	tc20		0.37	0.53	0.69	μs	Load 20pF
	tc100		1.87	2.67	3.47	μs	Load 100pF
Linearity error* ¹	INL		-4.0	-	+4.0	LSB	
Differential linearity error* ^{1,*2}	DNL		-0.9	-	+0.9	LSB	
Output Voltage offset	V _{OFF}		-	-	10.0	mV	Code is 0x000
			-50.0	-	+5.5	mV	Code is 0x3FF
Analog output impedance	R _O		2.45	3.50	4.55	k Ω	D/A operation
			5.0	9.0	-	M Ω	D/A stop
Output undefined period	t _R	-	-	250	ns		
Power supply current* ¹	IDDA* ²	AVCC	190	314	440	μA	D/A 1ch. operation AV _{CC} =3.3V
			285	476	670	μA	D/A 1ch. operation AV _{CC} =5.0V
	IDSA		-	-	1.0	μA	D/A stop

*1: No-load

*2: Generates the max current by the CODE about 0x200

MB9AA30N Series

7. Low-Voltage Detection Characteristics

(1) Low-Voltage Detection Reset

(Ta = - 40°C to + 85°C)

Parameter	Symbol	Conditions	Value			Unit	Remarks
			Min	Typ	Max		
Detected voltage	V_{DLR}	SVHR = 0001	1.43	1.53	1.63	V	When voltage drops
Released voltage	V_{DHR}		1.53	1.63	1.73	V	When voltage rises
Detected voltage	V_{DLR}	SVHR = 0100	1.80	1.93	2.06	V	When voltage drops
Released voltage	V_{DHR}		1.90	2.03	2.16	V	When voltage rises
LVD stabilization wait time	T_{LVDRW}	-	-	-	$633 \times t_{CYCP}^*$	μs	
Detection/Release delay time	T_{LVDRD}	$dV/dt \geq -4mV/\mu s$	-	-	60	μs	

* : t_{CYCP} indicates the APB2 bus clock cycle time.

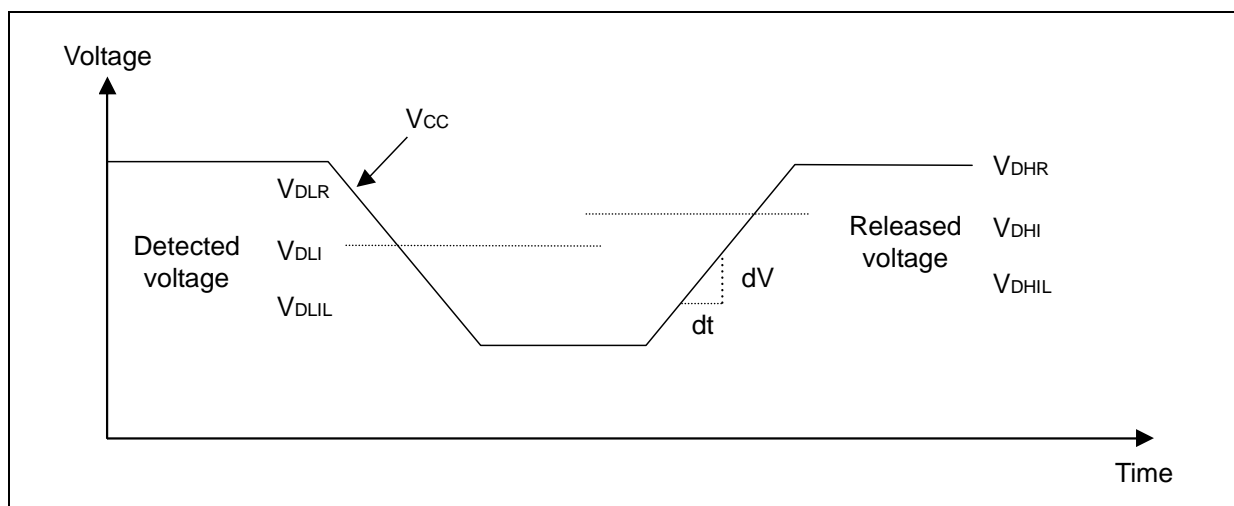

MB9AA30N Series

(2) Interrupt of Low-Voltage Detection

- Normal mode

(Ta = - 40°C to + 85°C)

Parameter	Symbol	Conditions	Value			Unit	Remarks
			Min	Typ	Max		
Detected voltage	V _{DLI}	SVHI = 0000	1.87	2.00	2.13	V	When voltage drops
Released voltage	V _{DHI}		1.97	2.10	2.23		When voltage rises
Detected voltage	V _{DLI}	SVHI = 0001	1.96	2.10	2.24	V	When voltage drops
Released voltage	V _{DHI}		2.06	2.20	2.34		When voltage rises
Detected voltage	V _{DLI}	SVHI = 0010	2.05	2.20	2.35	V	When voltage drops
Released voltage	V _{DHI}		2.15	2.30	2.45		When voltage rises
Detected voltage	V _{DLI}	SVHI = 0011	2.15	2.30	2.45	V	When voltage drops
Released voltage	V _{DHI}		2.25	2.40	2.55		When voltage rises
Detected voltage	V _{DLI}	SVHI = 0100	2.24	2.40	2.56	V	When voltage drops
Released voltage	V _{DHI}		2.34	2.50	2.66		When voltage rises
Detected voltage	V _{DLI}	SVHI = 0101	2.33	2.50	2.67	V	When voltage drops
Released voltage	V _{DHI}		2.43	2.60	2.77		When voltage rises
Detected voltage	V _{DLI}	SVHI = 0110	2.43	2.60	2.77	V	When voltage drops
Released voltage	V _{DHI}		2.53	2.70	2.87		When voltage rises
Detected voltage	V _{DLI}	SVHI = 0111	2.61	2.80	2.99	V	When voltage drops
Released voltage	V _{DHI}		2.71	2.90	3.09		When voltage rises
Detected voltage	V _{DLI}	SVHI = 1000	2.80	3.00	3.20	V	When voltage drops
Released voltage	V _{DHI}		2.90	3.10	3.30		When voltage rises
Detected voltage	V _{DLI}	SVHI = 1001	2.99	3.20	3.41	V	When voltage drops
Released voltage	V _{DHI}		3.09	3.30	3.51		When voltage rises
Detected voltage	V _{DLI}	SVHI = 1010	3.36	3.60	3.84	V	When voltage drops
Released voltage	V _{DHI}		3.46	3.70	3.94		When voltage rises
Detected voltage	V _{DLI}	SVHI = 1011	3.45	3.70	3.95	V	When voltage drops
Released voltage	V _{DHI}		3.55	3.80	4.05		When voltage rises
Detected voltage	V _{DLI}	SVHI = 1100	3.73	4.00	4.27	V	When voltage drops
Released voltage	V _{DHI}		3.83	4.10	4.37		When voltage rises
Detected voltage	V _{DLI}	SVHI = 1101	3.83	4.10	4.37	V	When voltage drops
Released voltage	V _{DHI}		3.93	4.20	4.47		When voltage rises
Detected voltage	V _{DLI}	SVHI = 1110	3.92	4.20	4.48	V	When voltage drops
Released voltage	V _{DHI}		4.02	4.30	4.58		When voltage rises
LVD stabilization wait time	T _{LVDIW}	-	-	-	633 × t _{CYCP} *	μs	
Detection/Release delay time	T _{LVDID}	dV/dt ≥ - 4mV/μs	-	-	60	μs	

* : t_{CYCP} indicates the APB2 bus clock cycle time.

MB9AA30N Series

• Low-power mode

(Ta = - 40°C to + 85°C)

Parameter	Symbol	Conditions	Value			Unit	Remarks
			Min	Typ	Max		
Detected voltage	V _{DLIL}	SVHI = 0000	1.80	2.00	2.20	V	When voltage drops
Released voltage	V _{DHIL}		1.90	2.10	2.30	V	When voltage rises
Detected voltage	V _{DLIL}	SVHI = 0001	1.89	2.10	2.31	V	When voltage drops
Released voltage	V _{DHIL}		1.99	2.20	2.41	V	When voltage rises
Detected voltage	V _{DLIL}	SVHI = 0010	1.98	2.20	2.42	V	When voltage drops
Released voltage	V _{DHIL}		2.08	2.30	2.52	V	When voltage rises
Detected voltage	V _{DLIL}	SVHI = 0011	2.07	2.30	2.53	V	When voltage drops
Released voltage	V _{DHIL}		2.17	2.40	2.63	V	When voltage rises
Detected voltage	V _{DLIL}	SVHI = 0100	2.16	2.40	2.64	V	When voltage drops
Released voltage	V _{DHIL}		2.26	2.50	2.74	V	When voltage rises
Detected voltage	V _{DLIL}	SVHI = 0101	2.25	2.50	2.75	V	When voltage drops
Released voltage	V _{DHIL}		2.35	2.60	2.85	V	When voltage rises
Detected voltage	V _{DLIL}	SVHI = 0110	2.34	2.60	2.86	V	When voltage drops
Released voltage	V _{DHIL}		2.44	2.70	2.96	V	When voltage rises
Detected voltage	V _{DLIL}	SVHI = 0111	2.52	2.80	3.08	V	When voltage drops
Released voltage	V _{DHIL}		2.62	2.90	3.18	V	When voltage rises
Detected voltage	V _{DLIL}	SVHI = 1000	2.70	3.00	3.30	V	When voltage drops
Released voltage	V _{DHIL}		2.80	3.10	3.40	V	When voltage rises
Detected voltage	V _{DLIL}	SVHI = 1001	2.88	3.20	3.52	V	When voltage drops
Released voltage	V _{DHIL}		2.98	3.30	3.62	V	When voltage rises
Detected voltage	V _{DLIL}	SVHI = 1010	3.24	3.60	3.96	V	When voltage drops
Released voltage	V _{DHIL}		3.34	3.70	4.06	V	When voltage rises
Detected voltage	V _{DLIL}	SVHI = 1011	3.33	3.70	4.07	V	When voltage drops
Released voltage	V _{DHIL}		3.43	3.80	4.17	V	When voltage rises
Detected voltage	V _{DLIL}	SVHI = 1100	3.60	4.00	4.40	V	When voltage drops
Released voltage	V _{DHIL}		3.70	4.10	4.50	V	When voltage rises
Detected voltage	V _{DLIL}	SVHI = 1101	3.69	4.10	4.51	V	When voltage drops
Released voltage	V _{DHIL}		3.79	4.20	4.61	V	When voltage rises
Detected voltage	V _{DLIL}	SVHI = 1110	3.78	4.20	4.62	V	When voltage drops
Released voltage	V _{DHIL}		3.88	4.30	4.72	V	When voltage rises
LVD stabilization wait time	T _{LVDILW}	-	-	-	8039 × t _{CYCP} *	μs	
Detection/Release delay time	T _{LVDILD}	dV/dt ≥ - 0.4mV/μs	-	-	800	μs	

* : t_{CYCP} indicates the APB2 bus clock cycle time.

8. Flash Memory Write/Erase Characteristics

(V_{CC} = 2.0V to 5.5V, Ta = - 40°C to + 85°C)

Parameter		Value			Unit	Remarks
		Min	Typ	Max		
Sector erase time	Large Sector	-	0.6	3.1	s	Excludes write time prior to internal erase
	Small Sector		0.3	1.6		
Half word (16-bit) write time		-	25	400	μs	Not including system-level overhead time.
Chip erase time		-	1.8	9.4	s	Excludes write time prior to internal erase

Write cycles and data hold time

Erase/write cycles (cycle)	Data hold time (year)	Remarks
1,000	20 *	
10,000	10 *	
100,000	5*	

*: This value comes from the technology qualification (using Arrhenius equation to translate high temperature acceleration test result into average temperature value at + 85°C) .

■ ORDERING INFORMATION

Part number	Package
MB9AFA31LPMC1	Plastic • LQFP(0.5mm pitch), 64-pin (FPT-64P-M38)
MB9AFA32LPMC1	
MB9AFA31LPMC	Plastic • LQFP(0.65mm pitch), 64-pin (FPT-64P-M39)
MB9AFA32LPMC	
MB9AFA31LQN	Plastic • QFN(0.5mm pitch), 64-pin (LCC-64P-M24)
MB9AFA32LQN	
MB9AFA31MPMC	Plastic • LQFP(0.5mm pitch), 80-pin (FPT-80P-M37)
MB9AFA32MPMC	
MB9AFA31MPMC1	Plastic • LQFP(0.65mm pitch), 80-pin (FPT-80P-M40)
MB9AFA32MPMC1	
MB9AFA31NPMC	Plastic • LQFP(0.5mm pitch), 100-pin (FPT-100P-M23)
MB9AFA32NPMC	
MB9AFA31NPF	Plastic • QFP(0.65mm pitch), 100-pin (FPT-100P-M06)
MB9AFA32NPF	
MB9AFA31NBGL	Plastic • PFBGA(0.8mm pitch), 112-pin (BGA-112P-M04)
MB9AFA32NBGL	

MB9AA30N Series

■ PACKAGE DIMENSIONS

<p>80-pin plastic LQFP</p> <p>(FPT-80P-M37)</p>	Lead pitch	0.50 mm
	Package width x package length	12.00 mm x 12.00 mm
	Lead shape	Gullwing
	Lead bend direction	Normal bend
	Sealing method	Plastic mold
	Mounting height	1.70 mm MAX
	Weight	0.47 g

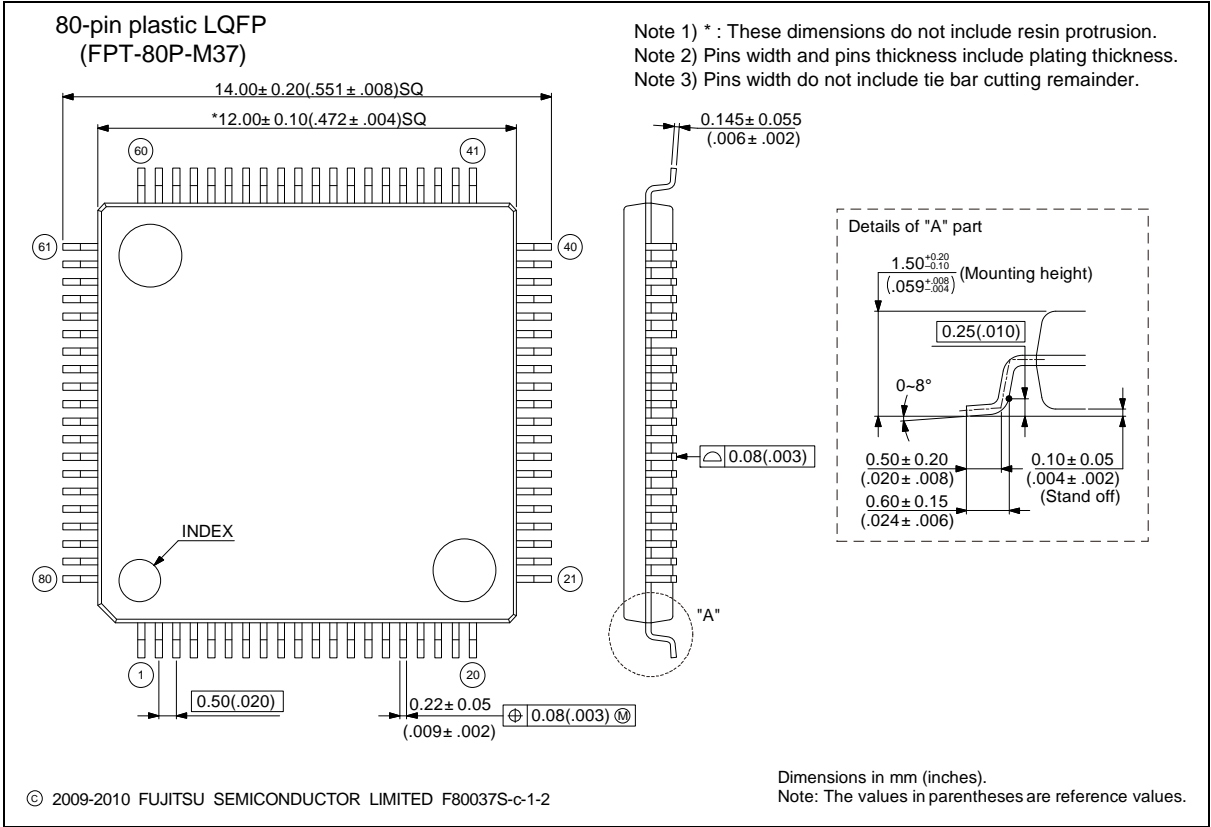

Please check the latest package dimension at the following URL.
<http://edevic.fujitsu.com/package/en-search/>

MB9AA30N Series

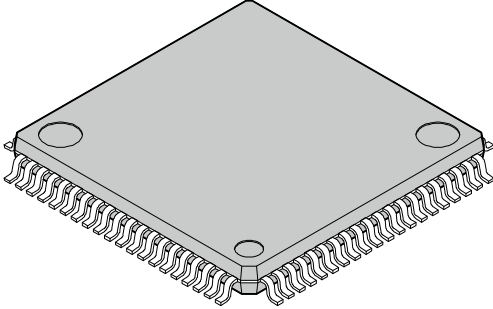
<p>80-pin plastic LQFP</p>  <p>(FPT-80P-M40)</p>	Lead pitch	0.65 mm
	Package width × package length	14.00 mm × 14.00 mm
	Lead shape	Gullwing
	Sealing method	Plastic mold
	Mounting height	1.60 mm Max.
	Code (Reference)	P-LQFP80-14 × 14-0.65

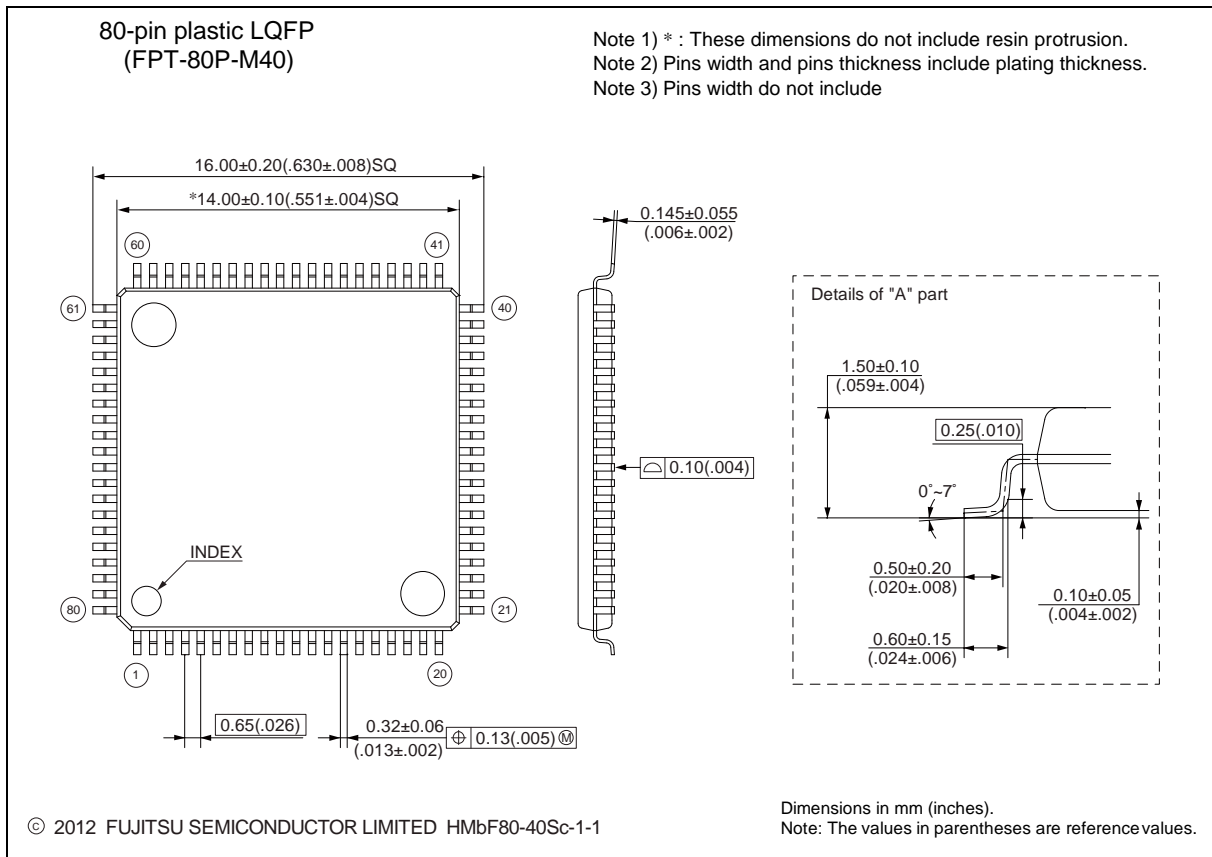

Please check the latest package dimension at the following URL.
<http://edevice.fujitsu.com/package/en-search/>

MB9AA30N Series

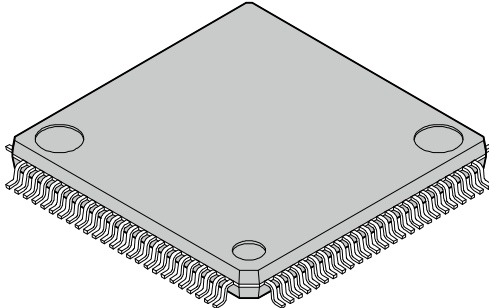
<p>100-pin plastic LQFP</p>  <p>(FPT-100P-M23)</p>	Lead pitch	0.50 mm
	Package width x package length	14.00 mm x 14.00 mm
	Lead shape	Gullwing
	Lead bend direction	Normal bend
	Sealing method	Plastic mold
	Mounting height	1.70 mm MAX
	Weight	0.65 g

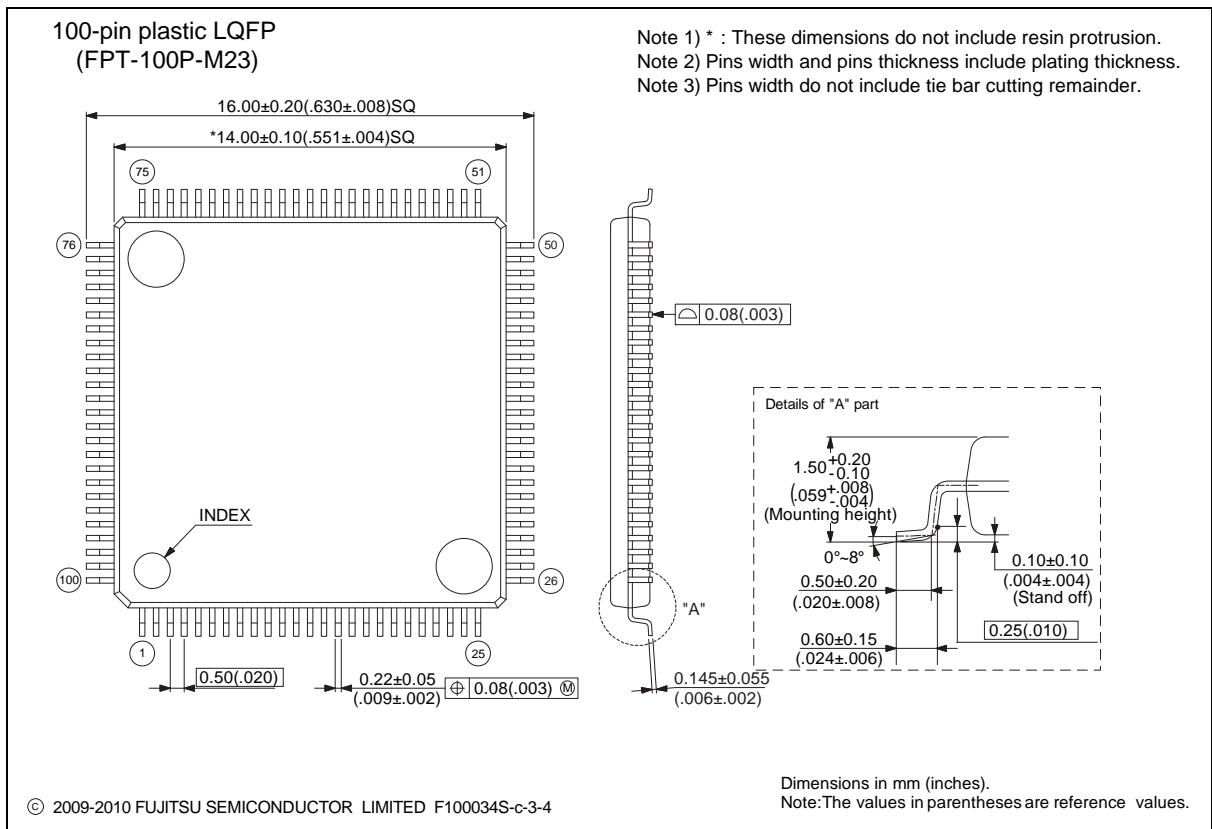

Please check the latest package dimension at the following URL.
<http://edevic.fujitsu.com/package/en-search/>

MB9AA30N Series

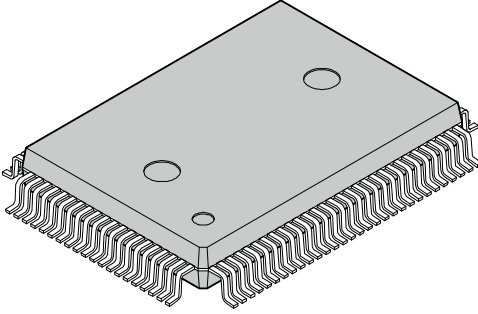
<p>100-pin plastic QFP</p>  <p>(FPT-100P-M06)</p>	Lead pitch	0.65 mm
	Package width x package length	14.00 x 20.00 mm
	Lead shape	Gullwing
	Sealing method	Plastic mold
	Mounting height	3.35 mm MAX
	Code (Reference)	P-QFP100-14x20-0.65

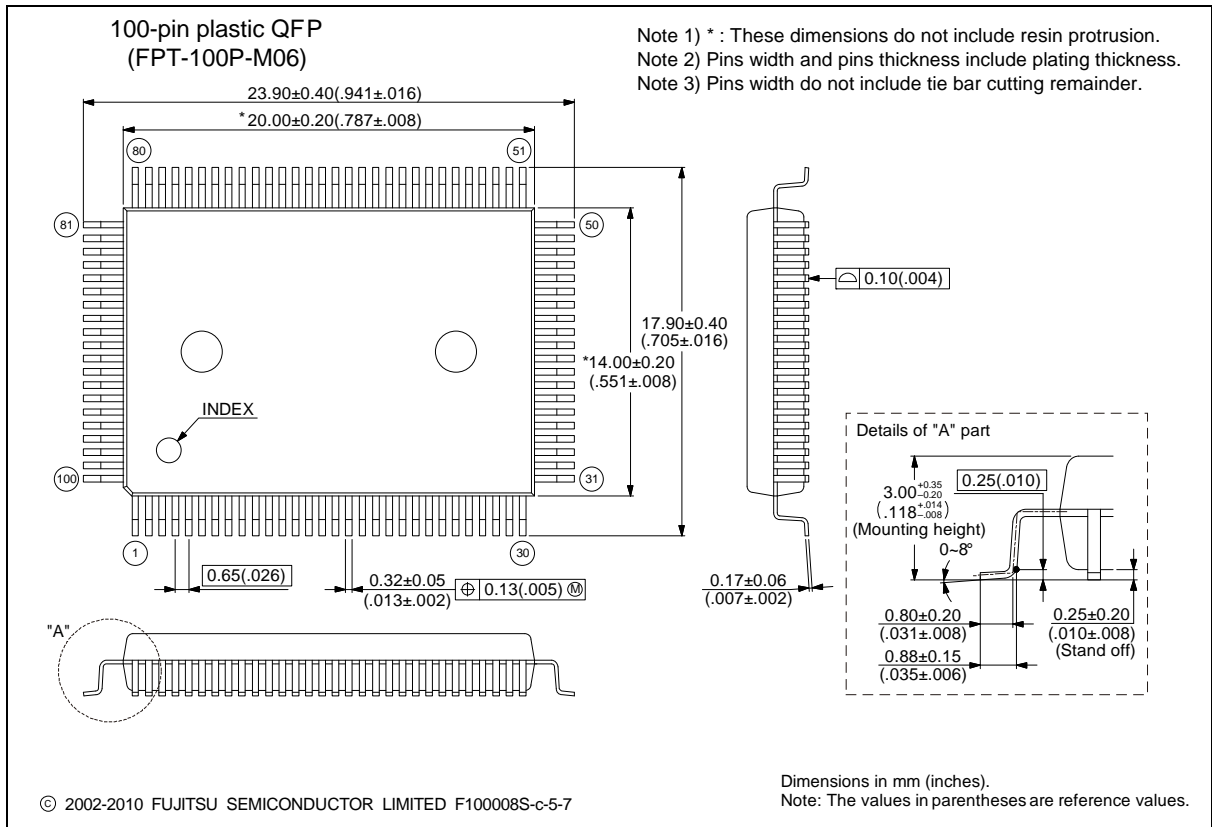

Please check the latest package dimension at the following URL.
<http://edevice.fujitsu.com/package/en-search/>

MB9AA30N Series

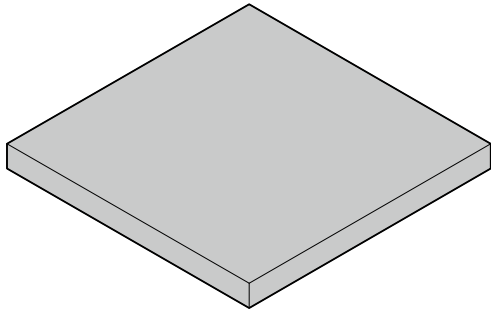
<p style="text-align: center;">112-ball plastic PFBGA</p>  <p style="text-align: center;">(BGA-112P-M04)</p>	Ball pitch	0.80 mm
	Package width x package length	10.00 x 10.00 mm
	Lead shape	Soldering ball
	Sealing method	Plastic mold
	Ball size	Φ 0.45 mm
	Mounting height	1.45 mm Max.
	Weight	0.22 g

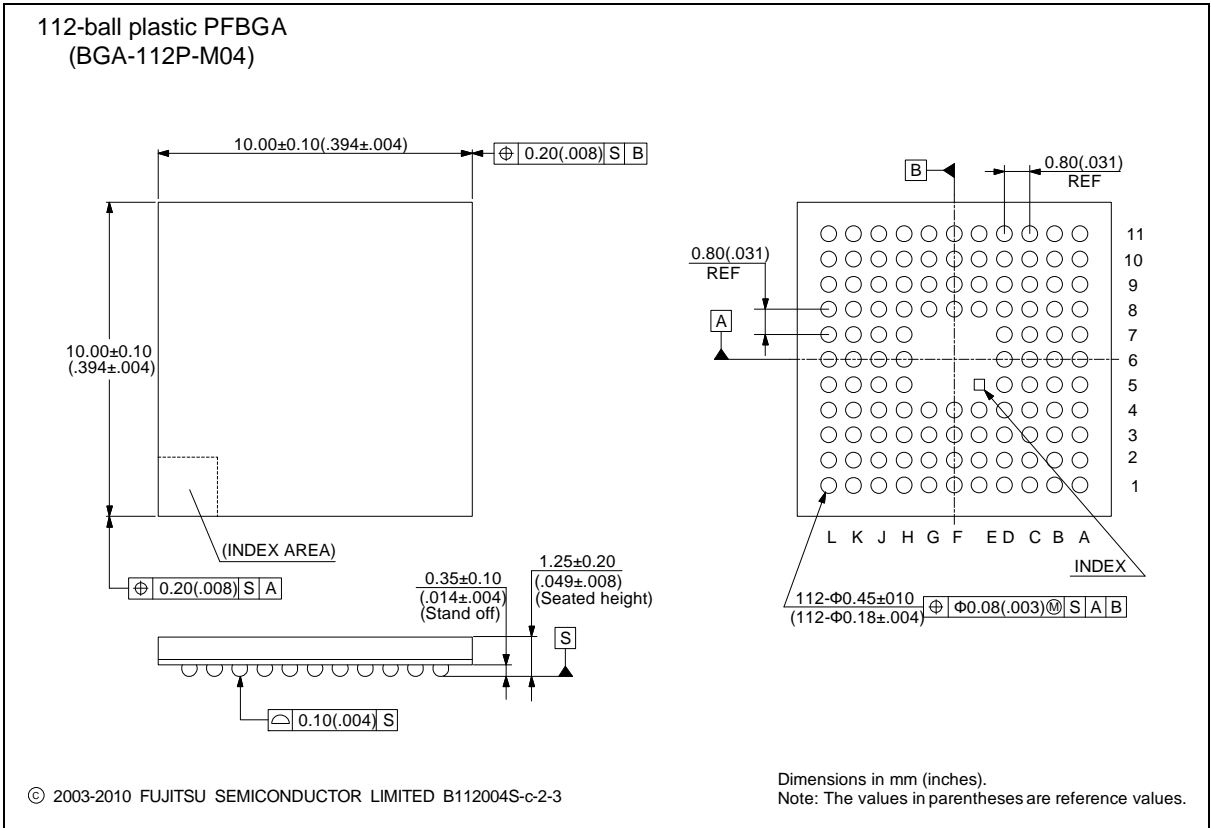

Please check the latest package dimension at the following URL.
<http://edevice.fujitsu.com/package/en-search/>

MB9AA30N Series

■ MAJOR CHANGES IN THIS EDITION

A change on a page is indicated by a vertical line drawn on the left side of that page.

Page	Section	Change Results
18	■LIST OF PIN FUNCTIONS • List of pin numbers	Revised the Pin state type.
26	• List of pin functions	Revised the pin name of "External Interrupt". INIT15_1 → INT15_1
63	■PIN STATUS IN EACH CPU STATE • List of pin status	• Added "Y" and "Z" type to the Pin status type. • Added the footnote.

MEMO

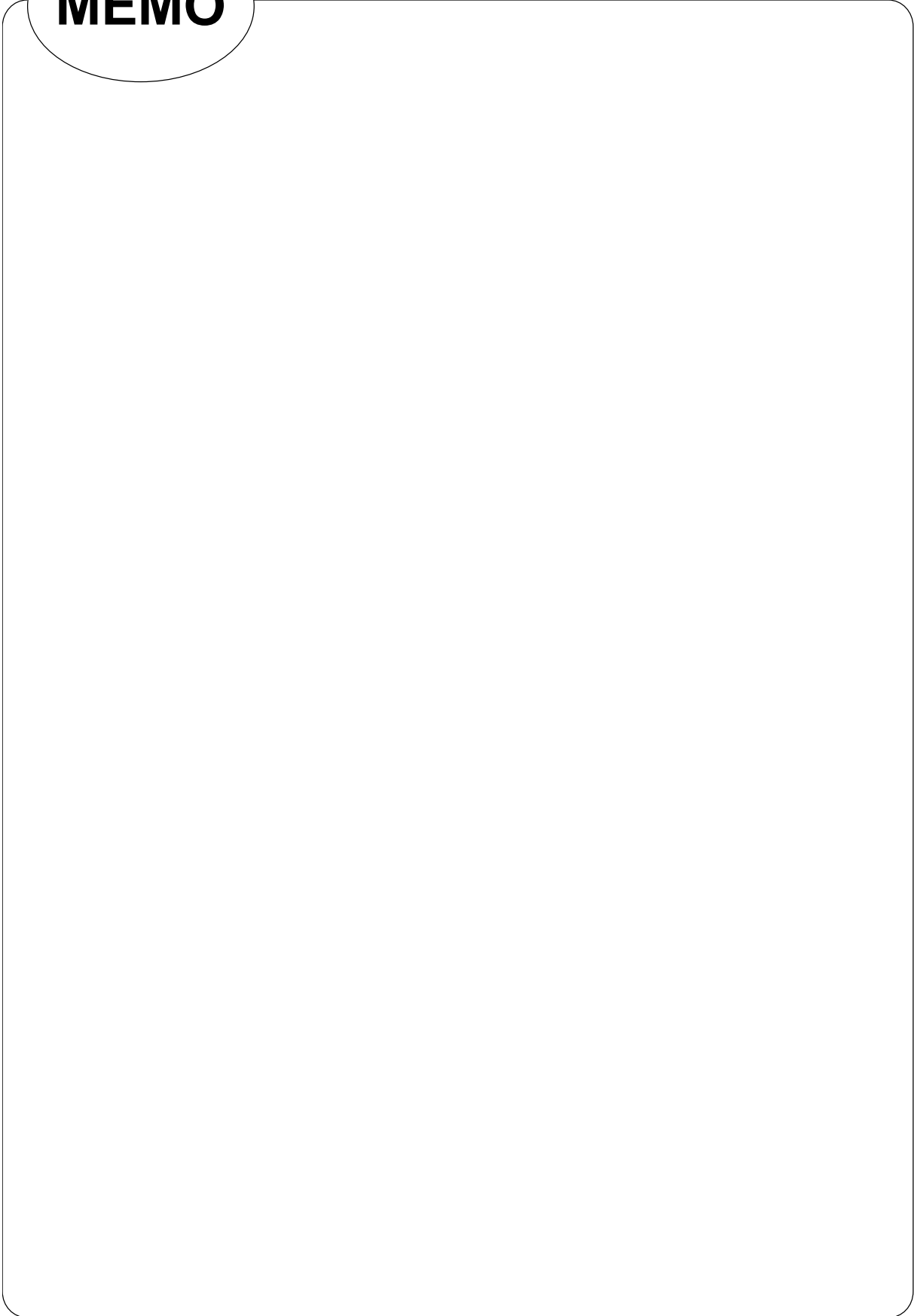

MEMO

MEMO

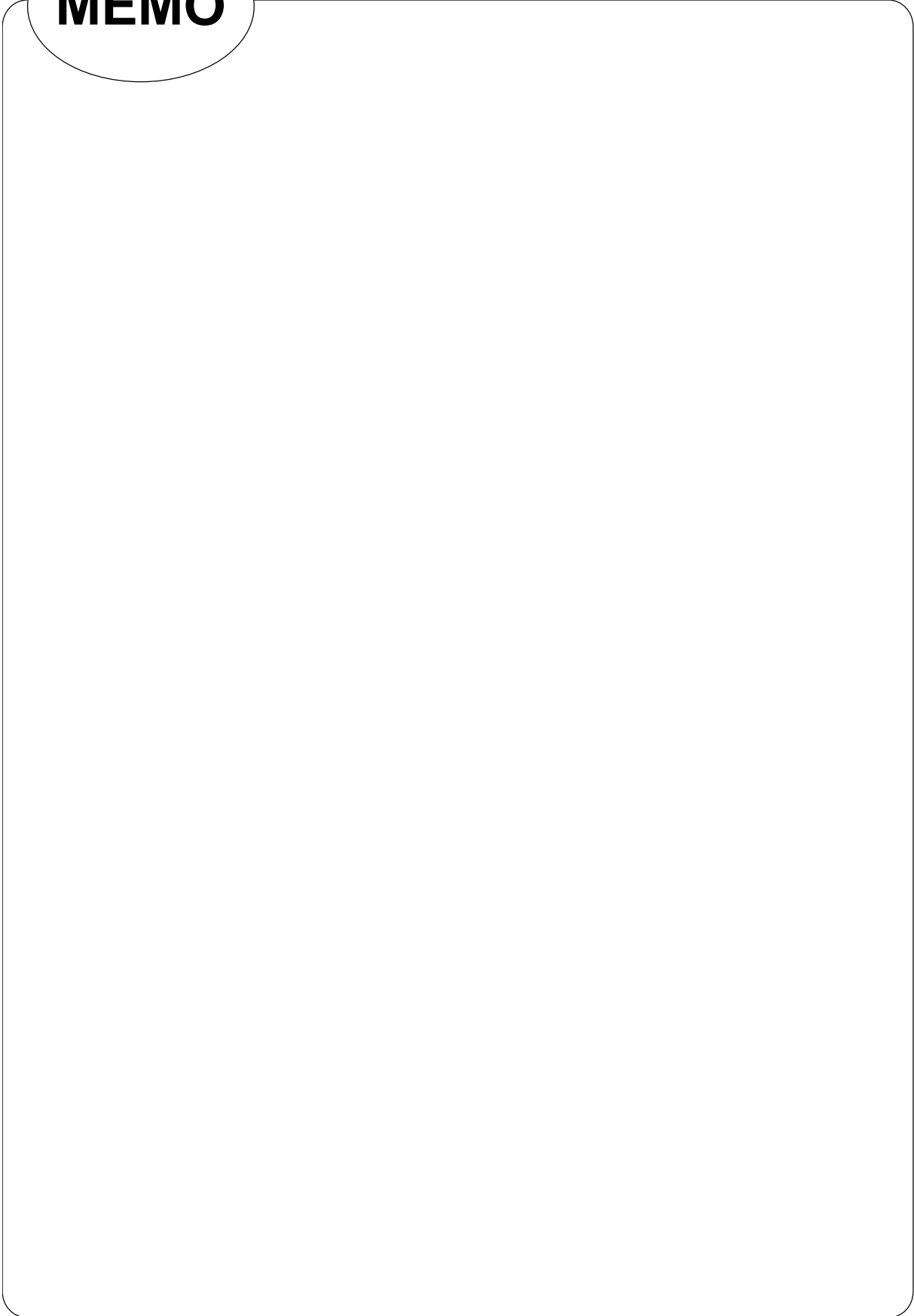

MB9AA30N Series

FUJITSU SEMICONDUCTOR LIMITED

Nomura Fudosan Shin-yokohama Bldg. 10-23, Shin-yokohama 2-Chome,
Kohoku-ku Yokohama Kanagawa 222-0033, Japan

Tel: +81-45-415-5858

<http://jp.fujitsu.com/fsl/en/>

For further information please contact:

North and South America

FUJITSU SEMICONDUCTOR AMERICA, INC.
1250 E. Arques Avenue, M/S 333
Sunnyvale, CA 94085-5401, U.S.A.
Tel: +1-408-737-5600 Fax: +1-408-737-5999
<http://us.fujitsu.com/micro/>

Asia Pacific

FUJITSU SEMICONDUCTOR ASIA PTE. LTD.
151 Lorong Chuan,
#05-08 New Tech Park 556741 Singapore
Tel : +65-6281-0770 Fax : +65-6281-0220
<http://sg.fujitsu.com/semiconductor/>

Europe

FUJITSU SEMICONDUCTOR EUROPE GmbH
Pittlerstrasse 47, 63225 Langen, Germany
Tel: +49-6103-690-0 Fax: +49-6103-690-122
<http://emea.fujitsu.com/semiconductor/>

FUJITSU SEMICONDUCTOR SHANGHAI CO., LTD.

30F, Kerry Parkside, 1155 Fang Dian Road,
Pudong District, Shanghai 201204, China
Tel : +86-21-6146-3688 Fax : +86-21-6146-3660
<http://cn.fujitsu.com/fss/>

Korea

FUJITSU SEMICONDUCTOR KOREA LTD.
902 Kosmo Tower Building, 1002 Daechi-Dong,
Gangnam-Gu, Seoul 135-280, Republic of Korea
Tel: +82-2-3484-7100 Fax: +82-2-3484-7111
<http://kr.fujitsu.com/fsk/>

FUJITSU SEMICONDUCTOR PACIFIC ASIA LTD.

2/F, Green 18 Building, Hong Kong Science Park,
Shatin, N.T., Hong Kong
Tel : +852-2736-3232 Fax : +852-2314-4207
<http://cn.fujitsu.com/fsp/>

All Rights Reserved.

FUJITSU SEMICONDUCTOR LIMITED, its subsidiaries and affiliates (collectively, "FUJITSU SEMICONDUCTOR") reserves the right to make changes to the information contained in this document without notice. Please contact your FUJITSU SEMICONDUCTOR sales representatives before order of FUJITSU SEMICONDUCTOR device.

Information contained in this document, such as descriptions of function and application circuit examples is presented solely for reference to examples of operations and uses of FUJITSU SEMICONDUCTOR device. FUJITSU SEMICONDUCTOR disclaims any and all warranties of any kind, whether express or implied, related to such information, including, without limitation, quality, accuracy, performance, proper operation of the device or non-infringement. If you develop equipment or product incorporating the FUJITSU SEMICONDUCTOR device based on such information, you must assume any responsibility or liability arising out of or in connection with such information or any use thereof. FUJITSU SEMICONDUCTOR assumes no responsibility or liability for any damages whatsoever arising out of or in connection with such information or any use thereof.

Nothing contained in this document shall be construed as granting or conferring any right under any patents, copyrights, or any other intellectual property rights of FUJITSU SEMICONDUCTOR or any third party by license or otherwise, express or implied. FUJITSU SEMICONDUCTOR assumes no responsibility or liability for any infringement of any intellectual property rights or other rights of third parties resulting from or in connection with the information contained herein or use thereof.

The products described in this document are designed, developed and manufactured as contemplated for general use including without limitation, ordinary industrial use, general office use, personal use, and household use, but are not designed, developed and manufactured as contemplated (1) for use accompanying fatal risks or dangers that, unless extremely high levels of safety is secured, could lead directly to death, personal injury, severe physical damage or other loss (including, without limitation, use in nuclear facility, aircraft flight control system, air traffic control system, mass transport control system, medical life support system and military application), or (2) for use requiring extremely high level of reliability (including, without limitation, submersible repeater and artificial satellite). FUJITSU SEMICONDUCTOR shall not be liable for you and/or any third party for any claims or damages arising out of or in connection with above-mentioned uses of the products.

Any semiconductor devices fail or malfunction with some probability. You are responsible for providing adequate designs and safeguards against injury, damage or loss from such failures or malfunctions, by incorporating safety design measures into your facility, equipments and products such as redundancy, fire protection, and prevention of overcurrent levels and other abnormal operating conditions.

The products and technical information described in this document are subject to the Foreign Exchange and Foreign Trade Control Law of Japan, and may be subject to export or import laws or regulations in U.S. or other countries. You are responsible for ensuring compliance with such laws and regulations relating to export or re-export of the products and technical information described herein.

All company names, brand names and trademarks herein are property of their respective owners.