

ZATARA® SERIES ADVANTAGE

- SINGLE-CHIP SOLUTION
- BEST FEATURE SET IN POS
- PCIPED PRE-CERTIFIED
- EMV L1 CERTIFIED
- TOTAL SOLUTION SUPPORT
- ZILOG ECOSYSTEM ALLIANCE

TARGET APPLICATIONS

- PAYMENT
- IDENTITY
- HEALTHCARE
- ACCESS CONTROL
- E-GOVERNMENT
- E-ADMINISTRATION

Zatara® Series ARM ASSP

High-Performance 32-bit Solution for Secure Transactions

Overview

Zilog, your choice for innovation and experience in the Secure Transaction industry, continues a tradition of excellence with the Zataras® Series 32-bit ARM ASSP. Based on the ARM® Architecture, the Zataras Series Application Specific Standard Products (ASSPs) are high-security and high-performance 32-bit Reduced Instruction Set Computing (RISC) System-on-Chips (SoCs), specifically designed for the secure transactions market.

A Complete Single-Chip Solution

The Zataras Series integrates security and application management functions required to build the next generation of trusted devices. Key device attributes that form the foundation of the product family include the following:

- A high performance 32-bit ARM922T™ core
- Robust data security with an integrated security sub-system
- Embedded card reading with SmartCard and magnetic stripe capabilities
- Flexible communication interfaces, including an integrated soft modem,USB, etc.

Due to the highly integrated peripheral set and embedded security features found on the Zataras Series devices, many cost and time benefits can be realized at the end user level by way of minimized component count, lower power consumption and lower bill of material costs - all of which equate to faster development time and reduced manufacturing costs and faster time-to-market for our customers.

To maximize safety and security, Zataras Series devices are PCIPED pre-certified as well as EMV Level 1 certified. Since these standards are becoming more and more of a requirement in today's security devices, Zilog has taken extra steps to ensure that your end devices are protected with trusted silicon and software.

Zatara[®] Series ARM ASSP Key Feature Summary

- ARM922T™ core
- Security Subsystem
 - Embedded secure boot ROM
 - Battery-backed security island
 - NIST 800-22 compliant random number generator
 - FIPS 180-2 compliant SHA-1 Hash generator
 - 64 KB embedded zero wait-state SRAM
 - 4 KB of embedded secure SRAM with fast zeroization
- Magnetic Card Reader (MCR)
- SmartCard controllers
- Integrated modem*
- LCD Monochrome Controller
- USB Dual-Role Controller (OTG)*
- 76 General Purpose Input/Output and Pin Muxing (16 dedicated)
- DMA, SDRAM, and interrupt controllers
- Power management features

Zatara[®] Series Block Diagram

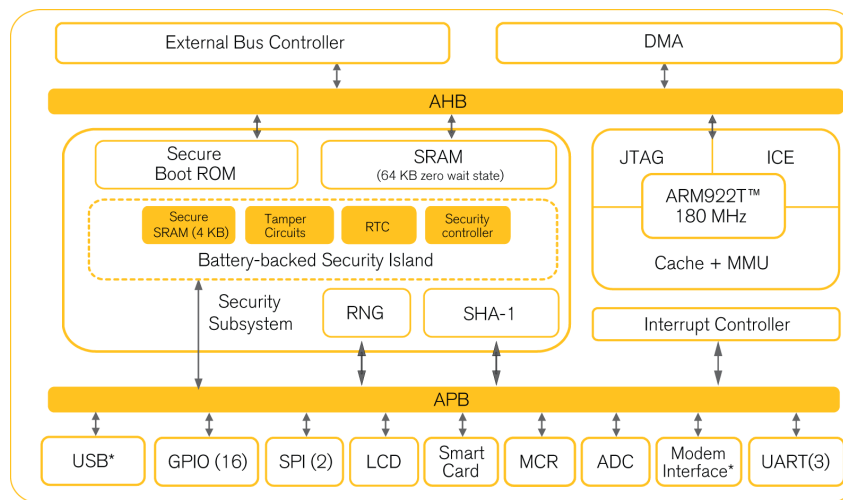

* : Selected parts only (see order information for more details)

KEY FEATURES

- SECURITY SUBSYSTEM
- PERIPHERAL SET FOR POS
- COMMUNICATION INTERFACES

Zatara[®] Series 32-Bit ASSP Detailed Feature Set

Security Subsystem

The security subsystem provides:

- Physical and Environmental protection
- Key Generation and Hash Algorithms
- Secure Storage and Zeroization
- Secure Boot

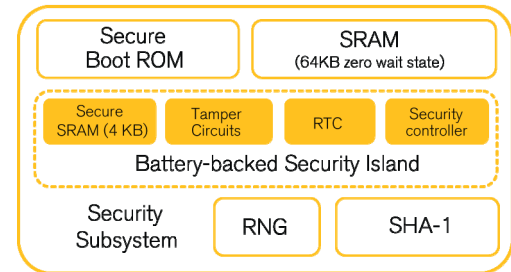

The internal battery power regulator supports the secure memory, the security controller, the tamper switches and the RTC. Tamper detection is done through a variety of sensors, including tamper switches, clock frequency and glitch protection as well as wire mesh sensors. In addition, the Zatara Series ASSPs integrate true 32-bit random number generation and Hash generation per the SHA-1 protocol. Maintain peace of mind and greater protection for your end applications with the Zatara Series Security Subsystem.

Comprehensive Peripheral Set

The Zatara Series offers a broad offering of peripherals that meet the needs of the secure transactions marketplace:

- SmartCard controllers (2) that interface directly to an ON semiconductor (NCN6001) or Phillips (TDA8002) SmartCard interface
- Magnetic Card Reader (MCR) that directly interfaces to the magnetic head and has simultaneous three-track reading. ISO 7811-3 and 7811-6 compliant
- Integrated soft modem through Integrated Data Access Arrangement (DAA) interface for connecting a Conexant modem (model #CX20493-5X)*
- Integrated LCD interface, directly compatible with popular monochrome LCD displays, text or graphic modes. The LCD display supports interfacing to 4-bit or 8-bit data; 3-control and 1-contrast

Communication Interfaces

Communication interfaces available on the Zatara Series include:

- External Bus Interface to standard asynchronous memories including SRAM, ROM, Flash and standard PC100/133 SDRAM
- Up to 76 GPIO pins (16 dedicated)
 - All configurable as edge interrupts or level interrupts
 - Full input/output or tri-state control
- Three UARTs
 - 1 x 8-wire interface
 - 2 x 4-wire interface (UART2 shared with IrDA encoder/decoder)
- Two dedicated SPI interfaces
- USB*
 - USB 2.0-compatible
 - Full Speed; On-the-Go (OTG)

* Selected parts only (see order information for more details)

KEY FEATURES

- PLATFORM SOFTWARE

Platform Software Support

The Zatarra Series platform software supports the greatest flexibility and stability on any OS environment (proprietary, Linux, etc.) to meet our customers' needs in their development environment.

The Zatarra Series Platform software package includes:

- Board Support Package (BSP) – root file system, tool chain, device drivers, boot loader, binary file signing tool
- Linux Development Platform – ported Linux operating system

Zilog Ecosystem Advantage

Zilog has formed key alliances with leaders in the security industry to provide our customers with the best possible array of security-ready platforms. Our partners work closely with us to complement and enhance the Zatarra Series platform.

Here are just a few of the strategic partners in the Zilog security ecosystem:



Zilog's Zatarra® Series platform offers the most interoperable, secure, and integrated solution for secure transactions in the market today.

Development Tool Support

The Zatara Series 32-bit ARM® solution includes the secure hardware platform, software environment and comprehensive set of development tools. The Zatara POS Reference Design Kits consists of:

- Reference Design Board with full collateral and schematics
- Zatara Series platform software package
- Zatara Series CPU silicon
- Signum JTAG (optional)

The Zatara Series microprocessors are based on ARM technology, allowing you to take advantage of a wide variety of tools and third party support available for ARM-based architectures. High performance, robust security and a rich feature set combine with Zilog's quality and industry reputation to make the Zatara Series 32-bit ASSP the right choice for your trusted devices.

Hardware Tools Ordering Information

- POS Reference Design Kit (part #: ZA9L0000300ZABG)

The POS Reference Design Kit contains the CPU card (processor, SDRAM, SRAM, Flash, Magnetic card reader, tamper switches and lithium battery) and application board (SmartCard, keypad, USB, Ethernet, printer interface, LCD, Compact Flash and Secure Digital card interface, RJ45 socket), and full BSP and ported Linux Development platform.

- POS Reference Design Kit with Signum Emulator (part #: ZA9L0000300ZEMG)

The POS Reference Design Kit contains the CPU card (processor, SDRAM, SRAM, Flash, Magnetic card reader, tamper switches and lithium battery) and application board (SmartCard, keypad, USB, Ethernet, printer interface, LCD, Compact Flash and Secure Digital card interface, RJ45 socket), and full BSP and ported Linux Development platform. This kit also includes a Signum JTAG Emulator that aids in the debug of your design in real-time.

- ZA9L1 Upgrade Kit (part #: ZA9L1000300MODG)

The ZA9L1 Upgrade Kit contains the CPU card (processor, SDRAM, SRAM, Flash, Magnetic card reader, tamper switches and lithium battery) only. The purpose of this kit is to upgrade your existing ZA9L0 POS Reference Design Kits mentioned above.

- POS Reference Design Kit (part #: ZA9L1000300ZABG)

The POS Reference Design Kit contains the CPU card (processor, SDRAM, SRAM, Flash, Magnetic card reader, tamper switches and lithium battery) and application board (SmartCard, keypad, USB, Ethernet, printer interface, LCD, Compact Flash and Secure Digital card interface, RJ45 socket), and full BSP and ported Linux Development platform.

- ZA9L1 POS Reference Design Kit with Signum Emulator (part #: ZA9L1000300ZEMG)

The POS Reference Design Kit contains the CPU card (processor, SDRAM, SRAM, Flash, Magnetic card reader, tamper switches and lithium battery) and application board (SmartCard, keypad, USB, Ethernet, printer interface, LCD, Compact Flash and Secure Digital card interface, RJ45 socket), and full BSP and ported Linux Development platform. This kit also includes a Signum JTAG Emulator that aids in the debug of your design in real-time.

Silicon Ordering Information

Order the Zatarra Series devices and tools from your local Zilog sales representative by using the part numbers below. For more information, or to download product collateral and/or software, please visit us at www.zilog.com.

Part Number	Security Subsystem	SmartCard Reader	Mag Stripe Reader	Embedded Modem	Dual Ext. Interface	USB	Tamper Security Inputs	I/O Lines	Timers with PWM	DMA Channels	ADC Channels	UARTs	SPI	Temp Range (-40°C to 85°C)	Pin and Package
ZA9L00		√	√		√		4	76	9	8	6	3	2	√	256-pin BGA
ZA9L01	√			√	√		4	76	9	8	6	3	2	√	256-pin BGA
ZA9L10	√	√	√		√	√	12	76	9	8	6	3	2	√	256-pin BGA
ZA9L11	√				√	√	12	76	9	8	6	3	2	√	256-pin BGA

Documentation

For a complete listing of all available application notes, product specifications, user manuals, and sample libraries, please visit us at www.zilog.com.

Document Number	Description
PS0260	Zatarra Series Essential ASSP (ZA9L0) Product Specification
PS0273	Zatarra Series ASSP (ZA9L0) Product Specification
PS0277	Zatarra Series ASSP (ZA9L1) Product Specification
QS0052	Board Support Package Quick Start Guide
QS0062	Linux Development Platform Quick Start Guide
RM0048	Board Support Package API Reference Manual
UM0205	Zatarra Series Development System User Manual
UM0211	Zatarra Series Boot Loader and Binary File Signing Tool User Manual

Note: The above documentation is restricted unless a signed Non-Disclosure Agreement (NDA) is provided and approved from an authorized Zilog representative. Detailed product specifications are subject to export control laws and regulations of the United States. Contact your Zilog sales representative for more information.



Warning: DO NOT USE IN LIFE SUPPORT

LIFE SUPPORT POLICY

ZILOG'S PRODUCTS ARE NOT AUTHORIZED FOR USE AS CRITICAL COMPONENTS IN LIFE SUPPORT DEVICES OR SYSTEMS WITHOUT THE EXPRESS PRIOR WRITTEN APPROVAL OF THE PRESIDENT AND GENERAL COUNSEL OF ZILOG CORPORATION.

As used herein

Life support devices or systems are devices which (a) are intended for surgical implant into the body, or (b) support or sustain life and whose failure to perform when properly used in accordance with instructions for use provided in the labeling can be reasonably expected to result in a significant injury to the user. A critical component is any component in a life support device or system whose failure to perform can be reasonably expected to cause the failure of the life support device or system or to affect its safety or effectiveness.

Document Disclaimer

©2008 by Zilog, Inc. All rights reserved. Information in this publication concerning the devices, applications, or technology described is intended to suggest possible uses and may be superseded. ZILOG, INC. DOES NOT ASSUME LIABILITY FOR OR PROVIDE A REPRESENTATION OF ACCURACY OF THE INFORMATION, DEVICES, OR TECHNOLOGY DESCRIBED IN THIS DOCUMENT. ZILOG ALSO DOES NOT ASSUME LIABILITY FOR INTELLECTUAL PROPERTY INFRINGEMENT RELATED IN ANY MANNER TO USE OF INFORMATION, DEVICES, OR TECHNOLOGY DESCRIBED HEREIN OR OTHERWISE. The information contained within this document has been verified according to the general principles of electrical and mechanical engineering.

Zatara is registered trademarks of Zilog, Inc. All other product or service names are the property of their respective owners.



EMBEDDED IN LIFE

WWW.ZILOG.COM | 408.513.1500

Zatara, Zilog, and the Zilog logo are registered trademarks of Zilog, Inc. in the United States and in other countries.

ARM[®] is a registered trademark of ARM Limited in the European Union and other countries. Microsoft and Windows are trademarks of Microsoft, Inc. in the US and other countries. All other product or service names are the property of their respective owners.

©Zilog, Inc., 2008. All rights reserved.