



C8051F230

8K Flash, 256 RAM, 48-Pin MCU

PRELIMINARY

ANALOG PERIPHERALS

Two Comparators

- Programmable Hysteresis
- Configurable to Generate Interrupts or Reset

VDD Monitor and Brown-out Detector

ON-CHIP JTAG DEBUG

- On-Chip Debug Circuitry Facilitates Full Speed, Non-Intrusive In-System Debug (No Emulator Required!)
- Provides Breakpoints, Single Stepping, Watchpoints, Stack Monitor
- Inspect/Modify Memory and Registers
- Superior Performance to Emulation Systems Using ICE-Chips, Target Pods, and Sockets
- Low Cost, Complete Development Kit

SUPPLY VOLTAGE 2.7V to 3.6V

- Typical Operating Current: 9mA @ 25MHz
- Typical Stop Mode Current: <0.1uA

Temperature Range: -40°C to +85°C

48-Pin TQFP Package

8051-COMPATIBLE μ C Core

- Pipelined Instruction Architecture; Executes 70% of Instructions in 1 or 2 System Clocks
- Up to **25MIPS** Throughput with 25MHz Clock
- Expanded Interrupt Handler

MEMORY

- 256 Bytes Data RAM
- 8k Bytes FLASH; In-System Programmable in 512 byte Sectors

DIGITAL PERIPHERALS

- 32 Port I/O (All 5V tolerant with High Sink Current)
- Hardware SPI™ and UART Serial Ports Available Concurrently
- Three General Purpose 16-bit Counter/Timers
- Dedicated Watch-Dog Timer; Bi-directional Reset

CLOCK SOURCES

- Internal Programmable Oscillator (2 to 16MHz)
- External Oscillator: Crystal, RC, C, or Clock
- Can Switch Between Clock Sources on-the-fly; Useful in Power Saving Modes

SPI is a trademark of Motorola, Inc.

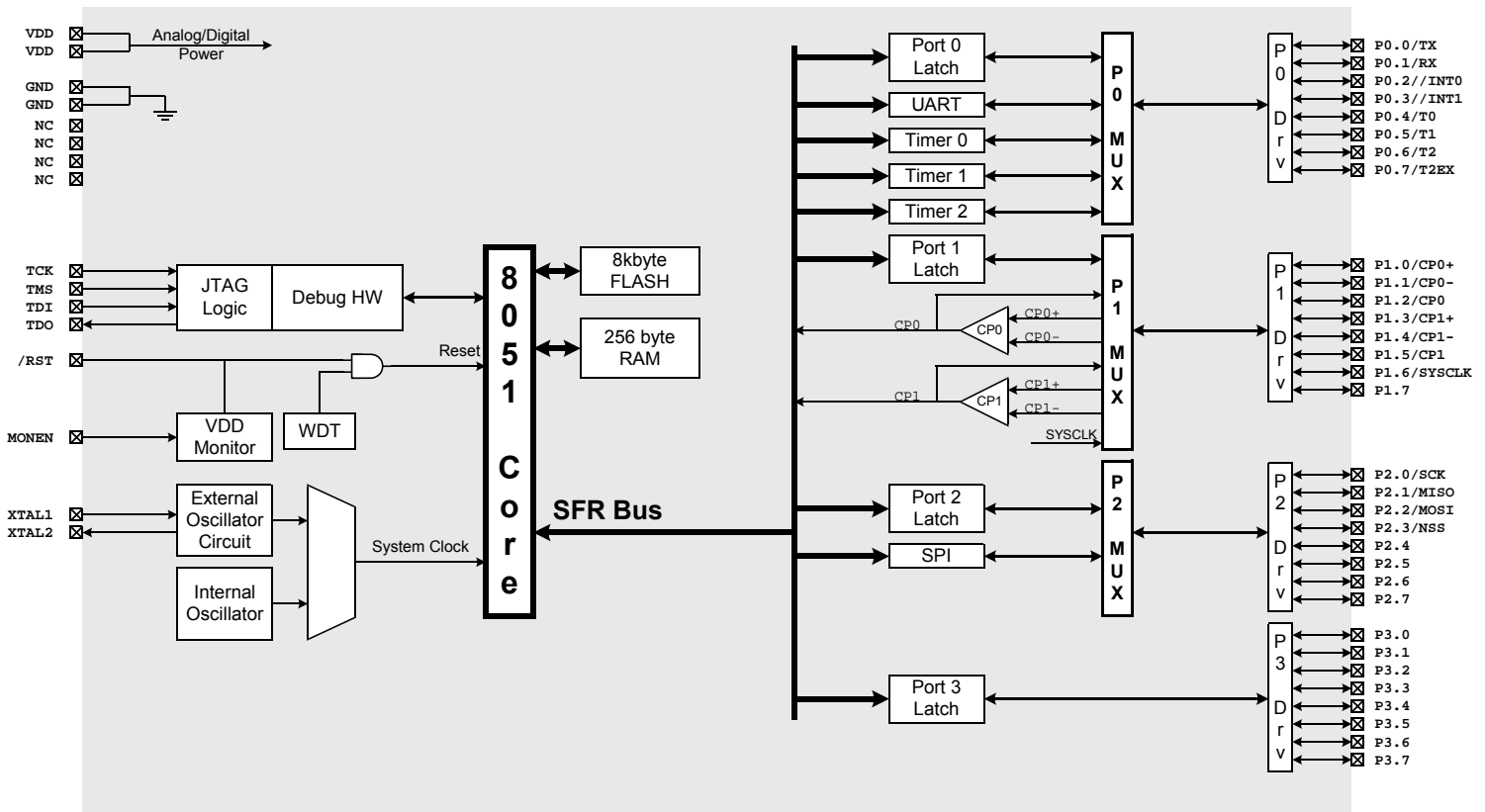

SELECTED ELECTRICAL SPECIFICATIONS $T_A = -40^{\circ}\text{C}$ to $+85^{\circ}\text{C}$, $V_{DD} = 2.7\text{V}$ unless otherwise specified.

PARAMETER	CONDITIONS	MIN	TYP	MAX	UNITS
GLOBAL CHARACTERISTICS					
Supply Voltage		2.7		3.6	V
Supply Current (CPU active)	Clock=25MHz		9		mA
	Clock=1MHz		0.4		mA
	Clock=32kHz; VDD Monitor Disabled		11		μA
Supply Current (shutdown)	Oscillator not running; VDD Monitor Enabled		10		μA
	Oscillator not running; VDD Monitor Disabled		0.1		μA
Clock Frequency Range		DC		25	MHz
COMPARATORS					
Supply Current	(each comparator)		1.5		μA
Response Time	(CP+) – (CP-) = 100mV		4.0		μs

PACKAGE INFORMATION

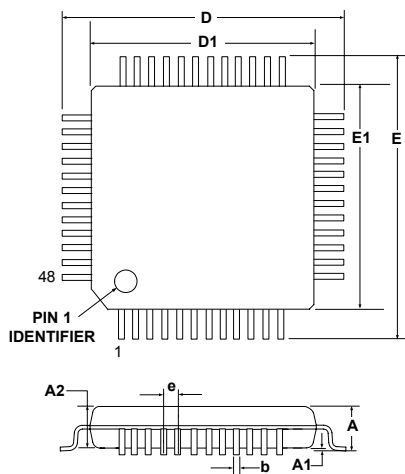

	MIN (mm)	NOM (mm)	MAX (mm)
A	-	-	1.20
A1	0.05	-	0.15
A2	0.95	1.00	1.05
b	0.17	0.22	0.27
D	-	9.00	-
D1	-	7.00	-
e	-	0.50	-
E	-	9.00	-
E1	-	7.00	-

C8051F226DK DEVELOPMENT KIT

