



8-BIT CID MICROCONTROLLER

Table of Contents-

1.	GENERAL DESCRIPTION	2
2.	FEATURES	2
3.	PIN CONFIGURATION	4
4.	PIN DESCRIPTION.....	5
5.	BLOCK DIAGRAM	7
6.	FUNCTIONAL DESCRIPTION	10
6.1	Memory Organization	11
6.2	Special Function Registers	14
6.3	Initial State of Registers.....	41
6.4	Instruction	42
6.5	Power Management.....	45
6.6	Reset.....	46
6.7	Interrupt.....	47
6.8	Programmable Timers/Counters	50
6.9	Serial Port	54
6.10	Comparator.....	61
6.11	DTMF Generator.....	62
6.12	FSK Generator.....	63
6.13	CAS Generator	64
6.14	I/O Ports.....	65
6.15	Divider.....	66
6.16	Timed Access Protection	66
6.17	Hardware Writer Mode.....	68
6.18	In-System Programming (ISP) Mode.....	68
6.19	Security Bits	81
6.20	Calling Identity Delivery (CID).....	83
7.	TIMING WAVEFORMS	97
7.1	Instruction Timing	98
8.	ELECTRICAL CHARACTERISTICS.....	101
8.1	Maximum Ratings*	101
8.2	Recommended Operating Conditions	101
8.3	DC Electrical Characteristics	102
8.4	Electrical Characteristics - Gain Control OP-Amplifier	104
8.5	AC Electrical Characteristics	104
9.	PACKAGE	107
10.	REVISION HISTORY	108



1. GENERAL DESCRIPTION

The W925EP01 is an all in one single 8-bit micro-controller with widely used Calling Identity Delivery (CID) function. The 8-bit CPU core is based on the 8051-family; therefore, all the instructions are compatible to the Turbo 8051 series.

That contains a 64K bytes of main Flash EPROM (APROM) and a 4K bytes of auxiliary Flash EPROM (LDROM) which allows the contents of the 64KB main Flash EPROM (APROM) to be updated by the loader program located at the 4KB auxiliary Flash EPROM (LDROM).

W925EP01 can be extend to two 64KB program banks, there are APROM (00000H~0FFFFH) and external program ROM (10000H~1FFFFH), user can access the external ROM by P5, P6, P7, A16 and $\overline{\text{PSEN}}$. All instructions are fetched for execution from this memory areas, the MOVC instruction can also access the external memory regions.

The CID part consisted of FSK decoder, DTMF receiver, CPE* Alert Signal (CAS) detector and Ring detector. Also are built-in DTMF generator, FSK generator with baud rate 1200 bps (bits/sec) and CAS generator.

Using W925EP01 can easily implement the CID adjunct box and the feature phone or Short Message Service (SMS) phone with CID function. The main features are listed in the next section.

2. FEATURES

- **CPU:** 8-bit micro-controller is similar to the 8051 family.
 - Flash EPROM type (E version) operating voltage:
 - μC: The μC operating voltage is from 2.4 to 5.5V. The ISP operating voltage is from 3.3 to 5.5V.
 - CID: The CID receiver operating voltage is from 3.0 to 5.5V.
- **Dual-clock operation:**
 - Main oscillator: Connect with 4M/8MHz crystal, built-in RC oscillator for clock stable from main crystal wake up.
 - Sub oscillator: connect with 32768Hz crystal.
 - Main and sub oscillators are enabled/disabled by bit control individually.
- **ROM:**
 - 64K bytes of in-system-programmable Flash EPROM for application program (APROM).
 - 4K bytes of auxiliary Flash EPROM for loader program (LDROM).
 - 64K bytes external program memories address space.
- **RAM:**
 - 256 bytes on chip scratch pad RAM.
 - 4K bytes on chip RAM for MOVX instruction.
 - 64K bytes external data memories address space.
- **CID**
 - Compatible with Bellcore TR-NWT-000030 & SR-TSV-002476, British Telecom (BT) SIN227, U.K. Cable Communication Association (CCA) specification.
 - FSK modulator/demodulator: for Bell 202 and ITU-T V.23 FSK with 1200-baud rate.
 - CAS generator/detector: for dual tones of Bellcore CAS and BT Idle State and Loop State Dual Tone Alert Signal (DTAS).
 - DTMF generator/receiver; DTMF receiver can be programmed as a tone detector.
 - Ring detector: for line reversal for BT, ring burst for CCA or ring signal for Bellcore.
 - Two independent OP amps with adjustable gain for Tip/Ring and Telephone Hybrid connections.

Note: "CPE*" Customer Premises Equipment



- **I/O:** 64 I/O pins.
 - P0: Bit and byte addressable. I/O mode can be bit controlled. Open drain type.
 - P1~P3: Bit and byte addressable. Pull high and I/O mode can be bit controlled.
 - P4: Byte addressable. Pull high and I/O mode can be bit controlled.
 - P5~P6: Byte addressable. Pull high and I/O mode can be bit controlled, P5~P6 also provide the address bus A0~A15 for access external program memory or data memory.
 - P7: Byte addressable. Pull high and I/O mode can be bit controlled, P7 also provide the data bus D0~D7 for access external program memory or data memory
- **Power mode:**
 - **Normal mode:** Normal operation.
 - **Dual-clock slow operation mode:** System is operated from the sub-oscillator. ($F_{osc}=F_s$ and F_m is stopped)
 - **Idle mode:** CPU hold. The clock to the CPU is halted, but the interrupt, timer and watchdog timer block work normally but CID function is disabled.
 - **Power down mode:** All activity is completely stopped and power consumption is less than 1uA.
- **Timer:** Dual 13/16-bit timers or 8-bit auto-reload timers, that are Timer0 and Timer1.
- **Watchdog timer:** WDT can be programmed by the user to serve as a system monitor.
- **Interrupt:** 12 interrupt sources with two levels of priority.
 - 4 interrupts from INT0, INT1, INT2 and INT3.
 - 2 interrupts from Timer0 and Timer1.
 - 2 interrupt from Serial port0 and Serial port1.
 - 1 interrupt from CID.
 - 1 interrupt from 13/14-bit Divider.
 - 1 interrupt from Comparator.
 - 1 interrupt from Watch Dog Timer.
- **Divider:** 13/14bit divider, clock source from sub-oscillator. Therefore, DIVF set every 0.25/0.5 second.
- **Comparator:**
 - Comparator: 1 analog input from VNEG pin. 1 reference input from VPOS pin.
- **Serial ports:**
 - Serial port0: One full duplex serial port. (UART)
 - Serial port1: An 8-bit serial transceiver with SCLK1 and SDATA1. (Serial interface port)
- **Package:**
 - 100pin QFP: W925EP01
 - 100pin lead-free QFP: W925EP01FG

W925EP01/ W925EP01FG



3. PIN CONFIGURATION

shows the pin assignment. The package type is 100pin QFP.

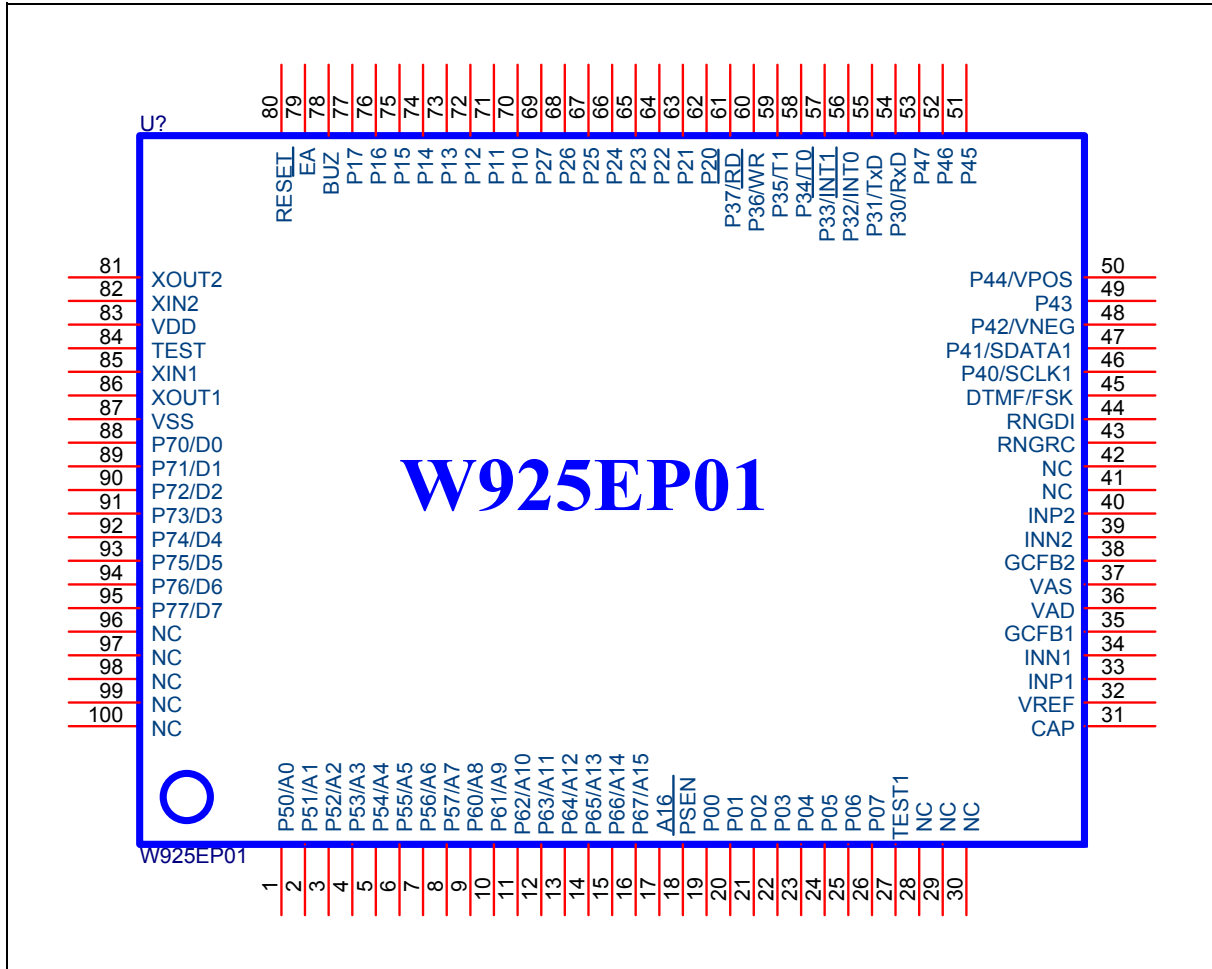

Figure 3-1 W925EP01 Pin Configuration

W925EP01/ W925EP01FG



4. PIN DESCRIPTION

SYMBOL	I/O	FUNCTION
RNGDI	I	Ring Detect Input (Schmitt trigger input). Used for ring detection and line reversal detection. Must maintain a voltage between VAD and VAS.
RNGRC	O	Ring RC (Open drain output and Schmitt trigger input). Used to set the time interval from the end of RNGDI pin to the inactive condition of the RNGON pin. An external resistor must be connected to VAD and a capacitor connected to VSS, the time interval is the RC time constant.
CAP	O	Must be connected 0.1uF capacitor to VSS.
VREF	O	Reference Voltage. Nominally, VDD/2 is used to bias the input of the gain control op-amp.
GCFB1	O	Op-amp1 Feed-back Gain Control signal. Select the input gain by connecting this pin and the INN1 pin with feedback resistor. It is recommended that the op-amp1 be set to unity gain.
INN1	I	Inverting Input of the gain control op-amp1.
INP1	I	Non-inverting Input of the gain control op-amp1.
GCFB2	O	Op-amp2 Feed-back Gain Control signal. Select the input gain by connecting this pin and the INN2 pin with feedback resistor. It is recommended that the op-amp2 be set to unity gain.
INN2	I	Inverting Input of the gain control op-amp2.
INP2	I	Non-inverting Input of the gain control op-amp2.
VAD	I	Analog voltage supply.
VAS	I	Analog ground.
VDD	I	Digital voltage supply.
VSS	I	Digital ground.
XOUT1	O	Output pin for main-oscillator. Connected to 4M/8MHz crystal for CID function.
XIN1	I	Input pin for main-oscillator. Connected to 4M/8MHz crystal for CID function.
XOUT2	O	Output pin for sub-oscillator. Connected to 32.768KHz crystal only. Suggest to add an external capacitor about 10~30pF to ground (VSS) for the accuracy of the oscillator.
XIN2	I	Input pin for sub-oscillator. Connected to 32.768KHz crystal only. Suggest to add an external capacitor about 10~30pF to ground (VSS) for the accuracy of the oscillator.
\overline{EA}	I	EXTERNAL ACCESS ENABLE. Set high for normal function. Set low for external mode running; P5~P6/A0~A15 and A16 are external address bus, P7/D0~D7 are external data bus, and \overline{PSEN} pin is always emits pulses during access to external ROM. This pin with internal pull-high resistor.

W925EP01/ W925EP01FG



Pin Description, continued

SYMBOL	I/O	FUNCTION
RESET	I	RESET pin. A high pulse causes the whole chip reset. This pin with internal pull-low resistor.
BUZ	O	Buzzer output pin. If buzzer function is disabled, BUZ pin is kept in floating state.
DTMF	O	DTMFG=1, CASGE=FTE=0, Dual-Tone Multi-Frequency (DTMF) signal output. FTE=1, CASGE=DTMFG=0, FSK signal output. CASGE=1, FTE=DTMF=0, CAS signal output. For signal send to the DTMF pin, CAS has the first priority, FSK has the second priority, and DTMF has the third priority.
P00-P07	I/O	Input/output port0. Port0 data can be bit controlled. The I/O mode is controlled by P0IO register. Port0 is open drain type when it is configured as output mode.
P10-P17	I/O	Input/output port1 with pull high resistors. Port1 data can be bit controlled. The I/O mode is controlled by P1IO register. The P10-P13 and P14-P17 indicate the external interrupt pins. (INT2 and INT3)
P20-P27	I/O	Input/output port2 with pull high resistors. Port2 data can be bit controlled. The I/O mode is controlled by P2IO register.
P30-P37	I/O	Input/output port3 with pull high resistors. Port3 data can be bit controlled. The I/O mode is controlled by P3IO register. The special function of port3 is referred to the description of P3 register.
P40-P47	I/O	Contents are byte controlled. Pull high and I/O mode can be bit controlled. The special function of P4 is referred to the description of P4 register. The comparator analog input pins V- and V+, share with P4.2 (VNEG) and P4.4 (VPOS) pins.
P50-P57	I/O	Contents are byte controlled. Pull high and I/O mode can be bit controlled. The special function of P5 is referred to the description of P5 register. P5 outputs the address <7:0> of the external program ROM multiplexed with the address <7:0> of the external data RAM.
P60-P67	I/O	Contents are byte controlled. Pull high and I/O mode can be bit controlled. The special function of P6 is referred to the description of P6 register. P6 outputs the address <7:0> of the external program ROM multiplexed with the address <15:8> of the external data RAM. During the execution of "MOVX @Ri", the output of P6 comes from the HB register, which is the high byte address, and its address is 0A1H.
P70-P77	I/O	Contents are byte controlled. Pull high and I/O mode can be bit controlled. The special function of P7 is referred to the description of P7 register. P7 inputs the data <7:0> of the external ROM. Or, P7 inputs/outputs the data <7:0> of the external data RAM.
TEST	I	Test pin. This pin has the built-in pull low resistor.
TEST1	I	Test pin, This pin must be fixed to VDD.
$\overline{\text{PSEN}}$	O	PROGRAM STORE ENABLE. This pin always emits pulses during access to external program ROM.



5. BLOCK DIAGRAM

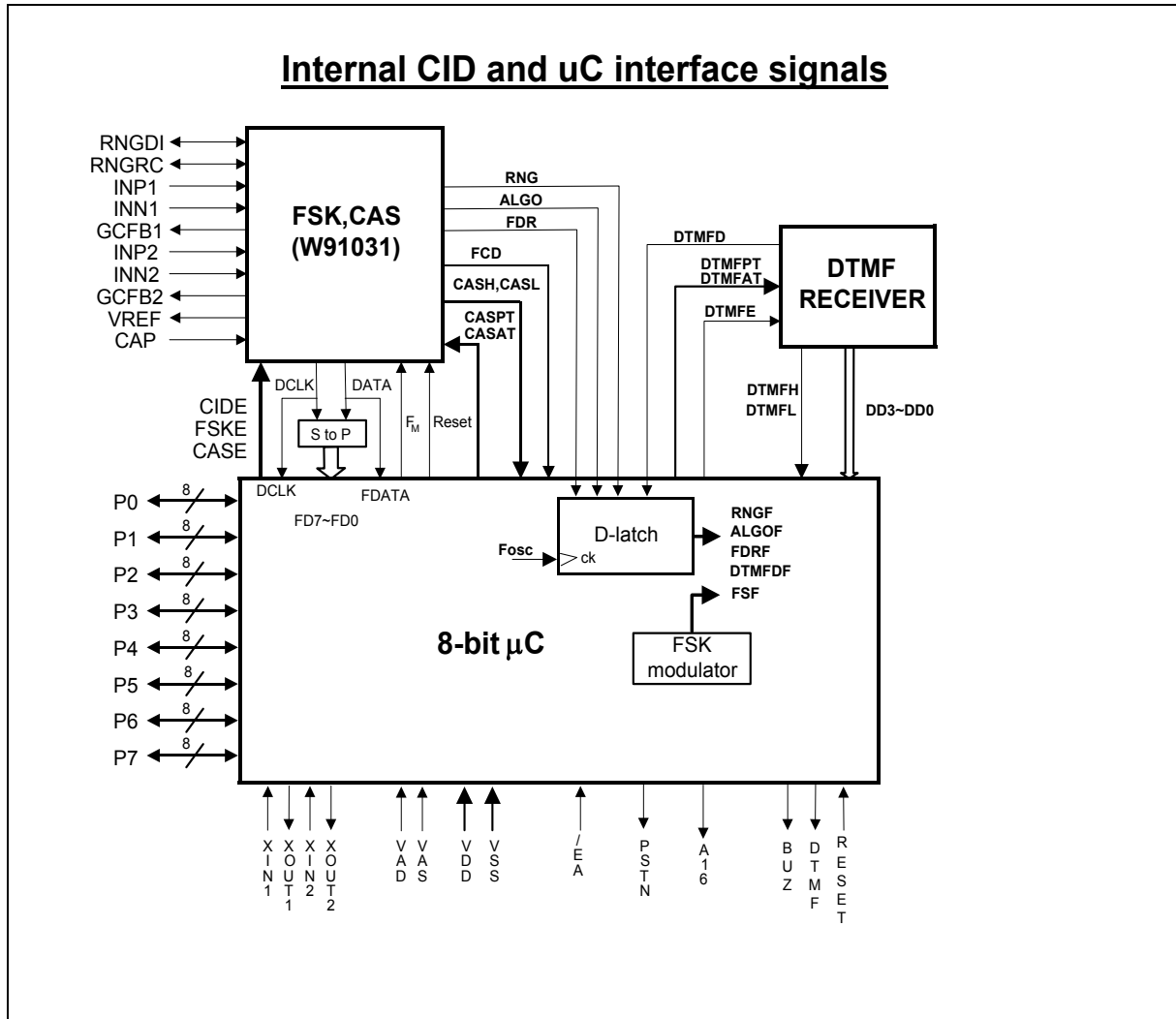

W925EP01/ W925EP01FG



NORMAL MODE WITH EXTERNAL 64KB PROGRAM ROM AND 64KB EXTERNAL DATA RAM:

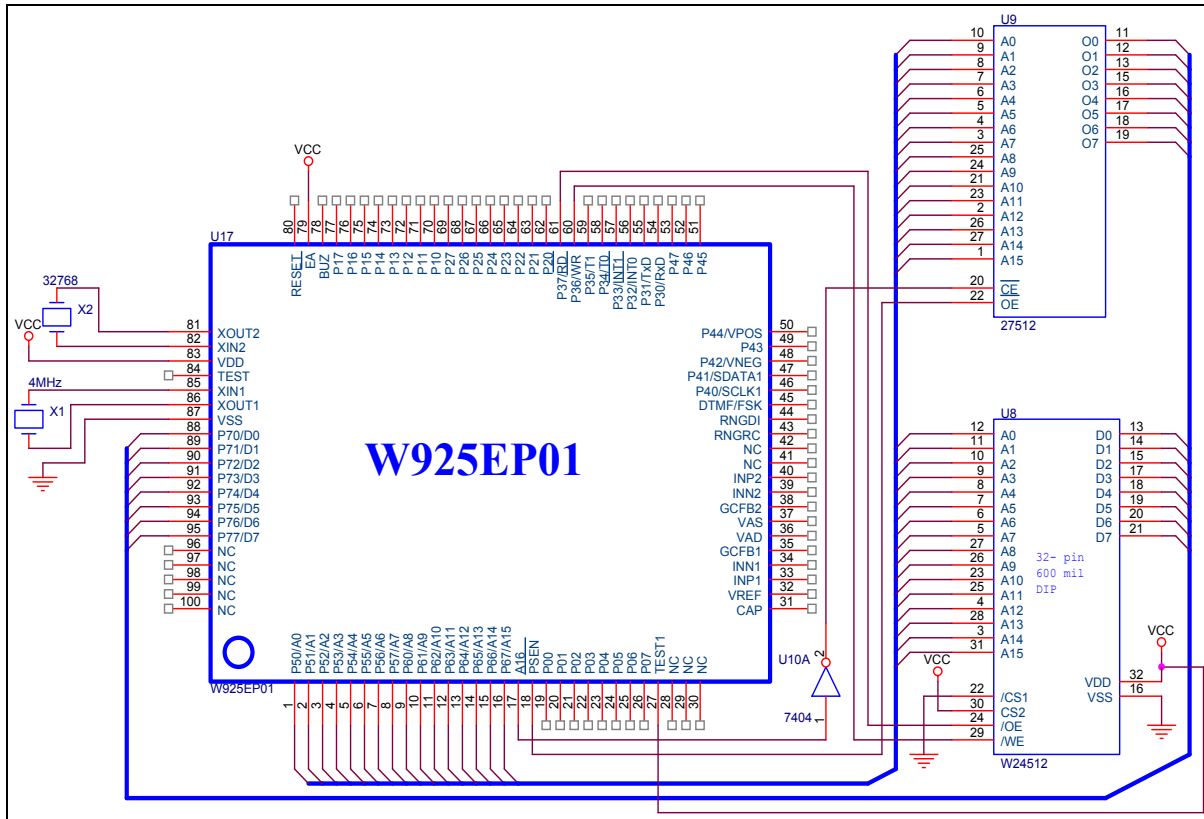

W925EP01/ W925EP01FG



EXTERNAL MODE WITH EXTERNAL 128KB PROGRAM ROM AND 64KB EXTERNAL DATA RAM:

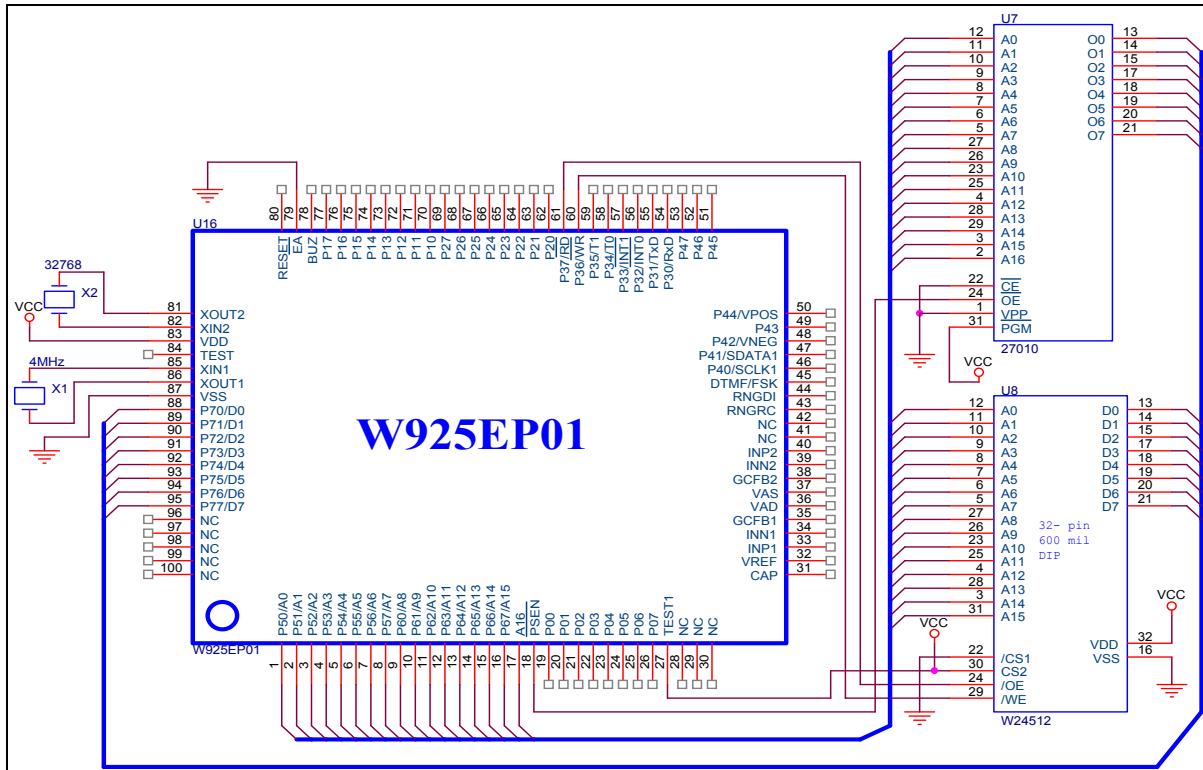



6. FUNCTIONAL DESCRIPTION

The W925EP01 is an 8-bit micro-controller with CID function. The 8-bit micro-control has the same instruction set as the 8051 family, with one addition: DEC DPTR (op-code A5H, the DPTR is decreased by 1). In addition, the W925EP01 contains on-chip 4K bytes MOVX RAM.

ROM:

The W925EP01 contains 64K bytes of main Flash EPROM (APROM) and a 4K bytes of auxiliary Flash EPROM which allows the contents of the 64KB main Flash EPROM to be updated by the loader program located at the 4KB auxiliary Flash EPROM.

The 64K bytes of in-system programmable Flash EPROM is for Application Program (APROM).

The 4K bytes of auxiliary Flash EPROM are for Loader Program (LDROM).

On-chip Data RAM:

The W925EP01 has 4K bytes of normal RAM which address is from 000H to FFFH. It only can be accessed by MOVX instruction; this on-chip RAM is optional under software control. The on-chip data RAM is not used for executable program memory. There is no conflict or overlap among the 256 bytes scratchpad RAM and the 4K bytes MOVX SRAM as they use different addressing modes and separate instructions. The on-chip MOVX SRAM will be enabled by set the DME0 bit in the PMR register. After a reset, the DME0 bit is set such that on-chip MOVX SRAM is enabled, and all MOVX data access to internal memory spaces is from 000H to FFFH.

CID:

The CID functions include the FSK decoder, CAS detector, and DTMF decoder and ring detector.

FSK modulator:

Support ITU-T V.23 and Bellcore 202 FSK transmit modulated signal to DTMF pin.

CAS modulator:

W925EP01 provides a CAS generator, which outputs the CAS signal to the DTMF pin.

DTMF modulator:

The W925EP01 is built-in a dual tone multi-frequency generator, the signal output to DTMF pin.

Eight I/O Ports:

The W925EP01 has eight 8-bit I/O ports giving 64 lines (Port0 to Port7). Port0 to Port3 can be used as an 8-bit general I/O port with bit-addressable; Port4 to Port7 can be used as an 8-bit general I/O port with byte-addressable. The I/O mode of each port is controlled by PxIO registers. Port1 to Port7 have internal pull high resistors enabled/disabled by PxH registers. Port0 is open-drain type in output mode.

TWO SERIAL I/O PORT:

The W925EP01 has two serial ports. The serial port0, through P3.0 (RxD) and P3.1 (TxD), is similar to the serial port of the original 8051 family. The serial port1, through P4.0 (SCLK1) and P4.1 (SDATA1), is an 8-bit synchronous serial I/O interface. The serial port0 have the enhanced features of Automatic Address recognition and Frame Error detection.

TWO TIMERS, WATCH DOG TIMER AND DIVIDER:

The W925EP01 has two 13/16-bit timers or 8-bits auto-reload timers. An independent watchdog timer is used as a system monitor or as a very long time period timer. A divider can produce the divider interrupt in every period of 0.5S or 0.25S.

Comparator:

The W925EP01 has an internal comparator with one external analog signal input path VNEG (P4.2) and an external reference input path VPOS (P4.4).



Interrupts:

The W925EP01 provides 12 interrupt resources with two priority levels, including 4 external interrupt sources, 2 timer interrupts, 1 CID interrupt, 1 divider interrupt, 2 serial port interrupt, 1 comparator interrupt and 1 watchdog timer interrupt.

Power Management:

The W925EP01 has IDLE and POWER DOWN modes of operation. In the IDLE mode, the clock to the CPU core is stopped however the functions of the timers, divider, CID and interrupts are active continuously. In the POWER DOWN mode, both of the system clocks stop oscillating and the chip operation is completely stopped. POWER DOWN mode is the state of the lowest power consumption.

6.1 Memory Organization

The W925EP01 separates the memory into two separate sections, the Program Memory and the Data Memory. The Program Memory is used to store the instruction op-codes and look-up table data, while the Data Memory is used to store data or for memory mapped devices.

Program Memory:

The W925EP01 is an 8-bit micro controller which has an in-system programmable EPROM for firmware updating. The instruction set of the W925EP01 is fully compatible with the standard 8052. The W925EP01 contains a 64K bytes of main EPROM and a 4K bytes of auxiliary Flash EPROM which allows the contents of the 64KB main EPROM to be updated by the loader program located at the 4KB auxiliary Flash EPROM. To facilitate programming and verification, the EPROM inside the W925EP01 allows the program memory to be programmed and read electronically. Once the code is confirmed, the user can protect the code for security.

The Program Memory on the W925EP01 can be up to 128K bytes. That is 64K bytes of on chip in-system programmable Flash EPROM (APROM) for Application Program and 64K bytes of external program ROM for code or data memory expansion.

The 4K bytes of auxiliary Flash EPROM (LDROM) are for Loader Program.

The whole 128K can be used to store look-up table data. Because the op-code is 64K addressable, a PG bit in PAGE register decides which ROM page between page0, page1 is enabled, and the ALU fetches the op-code from the selected ROM page. If PG=0, ALU fetches the op-code from page0. If PG=1, ALU fetches the op-code from page1. When MOV_C instruction is executed, ALU fetches the look-up table data according the indication of LT bits. The value of LT indicates which ROM page is active for look-up table instruction.

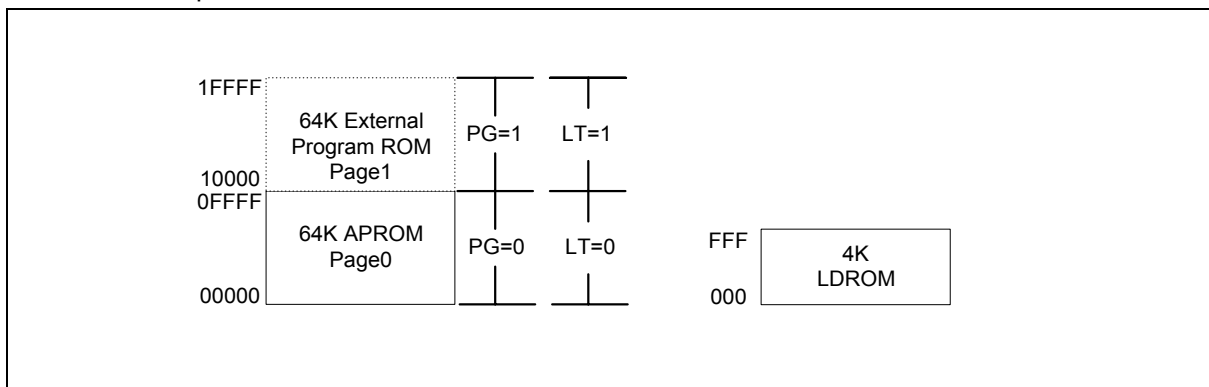

Figure 6-1 Program Memory Map

W925EP01/ W925EP01FG



Data Memory:

The W925EP01 contains on-chip 4K MOVX RAM of Data Memory, which can only be accessed by MOVX instructions from the address 000H to FFFH. Access to the on-chip MOVX SRAM is optional by software setting DME0 to "1", MOVX addresses greater than FFFH automatically go to external memory through A0 to A15; this is the default condition. When DME0 be clearing to "0", the 4K data memory area is transparent to the system memory map. Any MOVX directed to the space between 0000H to FFFFH goes to expanded bus on A0 to A15.

In addition, the W925EP01 has 256 bytes of on-chip scratchpad RAM. This can be accessed either by direct addressing or by indirect addressing. There are also Special Function Registers (SFRs), which can only be accessed by direct addressing. Since the scratchpad RAM is only 256 bytes, it can be used only when data contents are small.

In the event that larger data contents are present, the only one selection is external data memory. However, the on-chip RAM has the fastest access times. The memory map is shown Figure 6-2 and Figure 6-3 shows the scratched-pad RAM/register addressing.

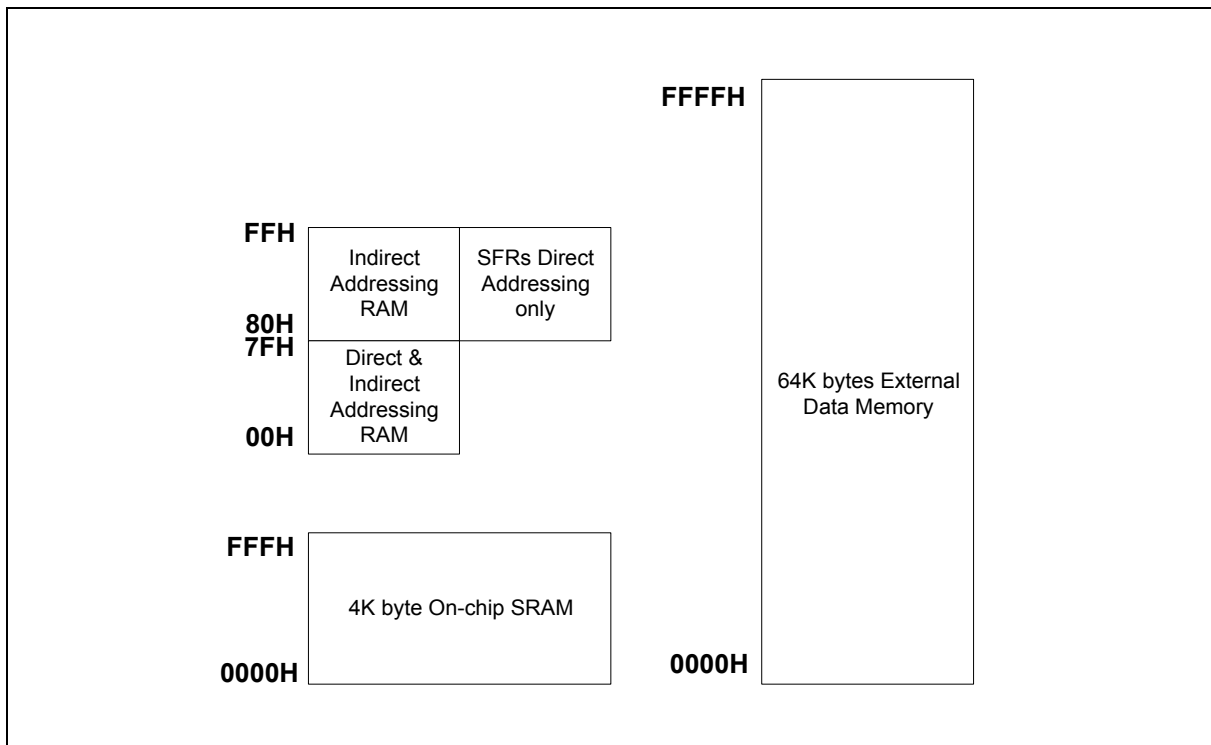

Figure 6-2 Data Memory Map

W925EP01/ W925EP01FG

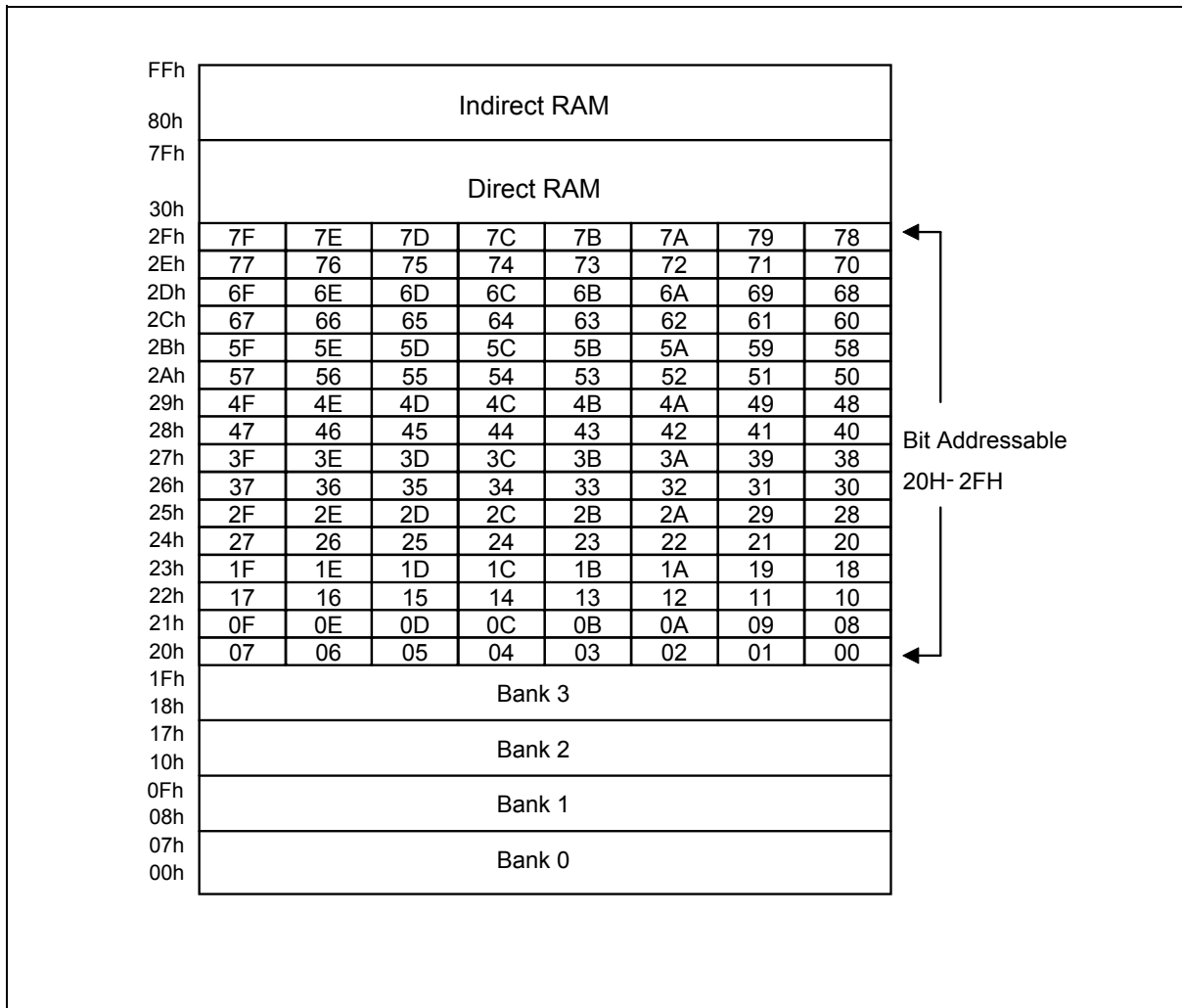

Figure 6-3 Scratchpad RAM/Register Addressing

W925EP01/ W925EP01FG



6.2 Special Function Registers

The W925EP01 uses Special Function Registers (SFRs) to control and monitor peripherals and their Modes.

The SFRs reside in the register locations 80-FFh and accessed by direct addressing only. Some of the SFRs are bit addressable. This is very useful in cases where one wishes to modify a particular bit without changing the others. The SFRs that are bit addressable are those whose addresses end in 0 or 8. The list of SFRs is as follows. The table is condensed with eight locations per row. Empty locations indicate that there are no registers at these addresses. The content of reserved bits or registers is not guaranteed.

Table 1 Special Function Register Location Table

F8	EIP	CIDGD	CIDGA						FF
F0	B								F7
E8	EIE						TA	CHPCON	EF
E0	ACC				SFRAL	SFRAH	SFRFD	SFRCN	E7
D8	WDCON								DF
D0	PSW								D7
C8	DIVC						BGCON	BG	CF
C0	SCON1	SBUF1	REGVC		PMR	STATUS	FSKTC	FSKTB	C7
B8	IP		DTMFG	COMPR	IRC1	IRC2	CASPT	CASAT	BF
B0	P3	CIDR	CIDFG	CIDPCR	FSKDR	DTMFDR	DTMFPT	DTMFAT	B7
A8	IE		P6H	P7H	P7IO	P6IO	P4IO	P5IO	AF
A0	P2	HB	P4H	P5H	P7	P6	P4	P5	A7
98	SCON	SBUF		P1EF		P1H	P2H	P3H	9F
90	P1	EXIF	RPAGE	P1SR	P0IO	P1IO	P2IO	P3IO	97
88	TCON	TMOD	TL0	TL1	TH0	TH1	CKCON1	CKCON2	8F
80	P0	SP	DPL	DPH	DPL1	DPH1	DPS	PCON	87

Note: The SFRs in the column with dark borders are bit-addressable.

A brief description of the SFRs now follows.

PORT 0

(initial=FFH)

Bit:	7	6	5	4	3	2	1	0
	P0.7	P0.6	P0.5	P0.4	P0.3	P0.2	P0.1	P0.0

Mnemonic: P0

Address: 80h

W925EP01/ W925EP01FG



P0: P0 can be selected as input or output mode by the P0IO register. At initial reset, P0IO is set to FFH, P0 is used as input mode. When P0IO is set to 0, the P0 is used as CMOS open drain mode.

STACK POINTER

(initial=07H)

Bit:	7	6	5	4	3	2	1	0
	SP.7	SP.6	SP.5	SP.4	SP.3	SP.2	SP.1	SP.0

Mnemonic: SP

Address: 81h

SP: The Stack Pointer stores the scratchpad RAM address where the stack begins. In other words, it always points to the top of the stack.

DATA POINTER LOW

(initial=00H)

Bit:	7	6	5	4	3	2	1	0
	DPL.7	DPL.6	DPL.5	DPL.4	DPL.3	DPL.2	DPL.1	DPL.0

Mnemonic: DPL

Address: 82h

DPL: This is the low byte of the standard 8052 16-bit data pointer.

DATA POINTER HIGH

(initial=00H)

Bit:	7	6	5	4	3	2	1	0
	DPH.7	DPH.6	DPH.5	DPH.4	DPH.3	DPH.2	DPH.1	DPH.0

Mnemonic: DPH

Address: 83h

DPH: This is the high byte of the standard 8052 16-bit data pointer.

DATA POINTER LOW1

(initial=00H)

Bit:	7	6	5	4	3	2	1	0
	DPL1.7	DPL1.6	DPL1.5	DPL1.4	DPL1.3	DPL1.2	DPL1.1	DPL1.0

Mnemonic: DPL1

Address: 84h

DPL1: This is the low byte of the new additional 16-bit data pointer. That has been added to the W925EP01. The user can switch between DPL, DPH and DPL1, DPH1 simply by setting register DPS.0 = 1. The instructions that use DPTR will now access DPL1 and DPH1 in place of DPL and DPH. If they are not required, they used as conventional register locations by the user.

DATA POINTER HIGH1

(initial=00H)

Bit:	7	6	5	4	3	2	1	0
	DPH1.7	DPH1.6	DPH1.5	DPH1.4	DPH1.3	DPH1.2	DPH1.1	DPH1.0

Mnemonic: DPH1

Address: 85h

W925EP01/ W925EP01FG



DPH1: This is the high byte of the new additional 16-bit data pointer. That has been added to the W925EP01. The user can switch between DPL, DPH and DPL1, DPH1 simply by setting register DPS = 1. The instructions that use DPTR will now access DPL1 and DPH1 in place of DPL and DPH. If they are not required, they used as conventional register locations by the user.

DATA POINTER SELECT

(initial=00H)

Bit:	7	6	5	4	3	2	1	0
	-	-	-	-	-	-	-	DPS.0

Mnemonic: DPS

Address: 86h

DPS.0: This bit is used to select the DPL, DPH pair or the DPL1, DPH1 pair as the active Data Pointer. When set to 1, DPL1, DPH1 will be selected, otherwise DPL, DPH will be selected.

DPS.1-7: These bits are reserved, but will read 0.

POWER CONTROL

(initial=00H)

Bit:	7	6	5	4	3	2	1	0
	SMOD	SMOD0	SFS	IDLTL	GF1	GF0	PD	IDL

Mnemonic: PCON

Address: 87h

SMOD: This bit doubles the serial port0 baud rate in mode 1, 2, and 3 when set to 1.

SMOD0: Framing Error Detection Enable: When SMOD0 is set to 1, and then SCON.7 indicates a Frame Error and acts as the FE flag. When SMOD0 is 0, then SCON.7 acts as SM0.

SFS: Serial port0 mode1 and mode3 frequency source switch.

SFS=0 Serial port0 mode1 and mode3 frequency source is from Timer0

SFS=1 Serial port0 mode1 and mode3 frequency source is from Timer1

IDLTL: This bit controls the idle mode type. In idle mode when idle mode is released by any interrupt, if IDLTL=1 it will not jump to the corresponding interrupt; if IDLTL=0 it will jump to the corresponding interrupt.

GF1-0: These two bits are general-purpose user flags.

PD: Setting this bit causes the W925EP01 to go into the POWER DOWN mode. In this mode all the clocks are stopped and program execution is frozen. Power down mode can be released by INT0~INT3 and ring detection of CID interrupt.

IDL: Setting this bit causes the W925EP01 to go into the IDLE mode. The type of idle mode is selected by IDLTL. In this mode the clocks to the CPU are stopped, so program execution is frozen. But the clock path to the timer blocks and interrupt blocks is not stopped, and these blocks continue operating.

TIMER CONTROL

(initial=00H)

Bit:	7	6	5	4	3	2	1	0
	TF1	TR1	TF0	TR0	IE1	IT1	IE0	IT0

Mnemonic: TCON

Address: 88h

W925EP01/ W925EP01FG



- TF1: Timer 1 overflows flag. This bit is set when Timer 1 overflows. It is cleared automatically when the program does a timer 1 interrupt service routine. Software can also set or clear this bit.
- TR1: Timer 1 runs control. This bit is set or cleared by software to turn timer on or off.
- TF0: Timer 0 overflows flag. This bit is set when Timer 0 overflows. It is cleared automatically when the program does a timer 0 interrupt service routine. Software can also set or clear this bit.
- TR0: Timer 0 runs control. This bit is set or cleared by software to turn timer on or off.
- IE1: Interrupt 1 edge detects: Set by hardware when an edge/level is detected on $\overline{INT1}$. This bit is cleared by hardware when the service routine is vectored to only if the interrupt was edge triggered. Otherwise, it follows the pin.
- IT1: Interrupt 1 type control: Set/cleared by software to specify falling edge/ low level triggered external inputs.
- IE0: Interrupt 0 edge detects: Set by hardware when an edge/level is detected on $\overline{INT0}$. This bit is cleared by hardware when the service routine is vectored to only if the interrupt was edge triggered. Otherwise, it follows the pin.
- IT0: Interrupt 0 type control. Set/cleared by software to specify falling edge/ low level triggered external inputs.

TIMER MODE CONTROL

(initial=00H)

Bit:	7	6	5	4	3	2	1	0
	GATE	C/ \overline{T}	M1	M0	GATE	C/ \overline{T}	M1	M0

Mnemonic: TMOD

Address: 89h

Bit7~4 control timer 1, bit3~0 control timer0

GATE: Gating control. When this bit is set, Timer x is enabled only while \overline{INTx} pin is high and TRx control bit is set. When cleared, Timer x is enabled whenever TRx control bit is set.

C/ \overline{T} : Timer or Counter Select. When cleared, the timer is incremented by internal clocks. When set, the timer counts high-to-low edges of the Tx pin.

Note: X is either 0 or 1.

M1, M0: Mode Select bits:

M1	M0	Mode
0	0	Mode 0: 13-bits timer
0	1	Mode 1: 16-bits timer
1	0	Mode 2: 8-bits with auto-reload from Thx
1	1	Reserved

TIMER 0 LOW BYTE

(initial=00H)

Bit:	7	6	5	4	3	2	1	0
	TL0.7	TL0.6	TL0.5	TL0.4	TL0.3	TL0.2	TL0.1	TL0.0

Mnemonic: TL0

Address: 8Ah

W925EP01/ W925EP01FG



TL0.7-0: Timer 0 low byte register.

TIMER 1 LOW BYTE

(initial=00H)

Bit:	7	6	5	4	3	2	1	0
	TL1.7	TL1.6	TL1.5	TL1.4	TL1.3	TL1.2	TL1.1	TL1.0

Mnemonic: TL1

Address: 8Bh

TL1.7-0: Timer 1 low byte register.

TIMER 0 HIGH BYTE

(initial=00H)

Bit:	7	6	5	4	3	2	1	0
	TH0.7	TH0.6	TH0.5	TH0.4	TH0.3	TH0.2	TH0.1	TH0.0

Mnemonic: TH0

Address: 8Ch

TH0.7-0: Timer 0 high byte register.

TIMER 1 HIGH BYTE

(initial=00H)

Bit:	7	6	5	4	3	2	1	0
	TH1.7	TH1.6	TH1.5	TH1.4	TH1.3	TH1.2	TH1.1	TH1.0

Mnemonic: TH1

Address: 8Dh

TH1.7-0: Timer 1 high byte register.

CLOCK CONTROL1

(initial=00H)

Bit:	7	6	5	4	3	2	1	0
	WD1	WD0	T1S1	T1S0	T0S1	T0S0	DIVS	\bar{M}/S

Mnemonic: CKCON1

Address: 8Eh

WD1-0: Watchdog timer mode select bits: These bits determine the time-out period for the watchdog timer. In all four time-out options the reset time-out is 512 clocks more than the interrupt time-out period.

WD1	WD0	Interrupt time-out	Reset time-out
0	0	$F_{osc}/2^{12}$	$F_{osc}/2^{12} + 512$
0	1	$F_{osc}/2^{15}$	$F_{osc}/2^{15} + 512$
1	0	$F_{osc}/2^{18}$	$F_{osc}/2^{18} + 512$
1	1	$F_{osc}/2^{21}$	$F_{osc}/2^{21} + 512$

T0S0-1&T1S0-1: Timer0 & Timer1 clock source mode select bits. These bits determine the timer0 & timer1 clock source.

W925EP01/ W925EP01FG



T0S1 (T1S1)	T0S0 (T1S0)	Pre-scale clock source
0	0	$F_{osc}/2^2$
0	1	$F_{osc}/2^6$
1	0	$F_{osc}/2^{10}$
1	1	F_s

DIVS: Divider clock source control bit 1:

DIVS = 0: $F_s/2^{13}$

DIVS = 1: $F_s/2^{14}$

\bar{M}/S : System clock source control bit:

\bar{M}/S = 0: $F_{osc} = XIN1$ (FM)

\bar{M}/S = 1: $F_{osc} = XIN2$ (Fs)

CLOCK CONTROL2

(initial=00H)

Bit:	7	6	5	4	3	2	1	0
	ENBUZ	BUZSL	KT1	KT0	-	-	-	-

Mnemonic: CKCON2

Address: 8Fh

ENBUZ: When ENBUZ=1 the BUZ pin works as buzzer output, otherwise BUZ pin is in floating state.

BUZSL: Buzzer output selection. When BUZSL=0 BUZ is the output of octave tone. When BUZZL=1, BUZ is the output of key tone.

KT1-0: Key tone frequency sources from divider. When divider is enabled, KT1 and KT0 determine the key tone frequency.

KT1	KT0	KEY TONE FREQUENCY
0	0	Low
0	1	512Hz
1	0	1024Hz
1	1	2048Hz

PORT 1

(initial=FFH)

Bit:	7	6	5	4	3	2	1	0
	P1.7	P1.6	P1.5	P1.4	P1.3	P1.2	P1.1	P1.0

Mnemonic: P1

Address: 90h

P1.7-0: P1 can be selected as input or output mode by the P1IO register, at initial reset, P1IO is set to 1, so P1 is used as input mode. When P1IO is set to 0, the P1 is used as CMOS output mode. When P1EF are set and P1IO are set as input mode P1 can be used as external interrupt source. The functions are listed below.



- P1.0 : INT2.0 External Interrupt 2
- P1.1 : INT2.1 External Interrupt 2
- P1.2 : INT2.2 External Interrupt 2
- P1.3 : INT2.3 External Interrupt 2
- P1.4 : INT3.0 External Interrupt 3
- P1.5 : INT3.1 External Interrupt 3
- P1.6 : INT3.2 External Interrupt 3
- P1.7 : INT3.3 External Interrupt 3

EXTERNAL INTERRUPT FLAG

(initial=00H)

Bit:	7	6	5	4	3	2	1	0
	-	-	-	COMPF	DIVF	CIDF	IE3	IE2

Mnemonic: EXIF

Address: 91h

COMPF: Comparator flag. Set by hardware when RESC bit is from low to high.

DIVF: Divider overflow flag.

CIDF: CID interrupt flag. Set by hardware when at least one of CID flags is set.

IE3: External Interrupt 3 flag. Set by hardware when a falling edge is detected on INT3.

IE2: External Interrupt 2 flag. Set by hardware when a falling edge is detected on INT2.

ROM PAGE POINTER

(initial=00H)

Bit:	7	6	5	4	3	2	1	0
	-	-	-	LT	-	-	-	PG

Mnemonic: RPAGE

Address: 92h

LT: Determines the MOVC content reading is from ROM page0 or page1.

LT = 0 indicates the MOVC reading data is from the ROM page0.

LT = 1 indicates the MOVC reading data is from the ROM page1.

PG: Determines the program ROM page of the executing ROM page.

PG = 0 indicates the executing program is in page 0, from 00000H-0FFFFH

PG = 1 indicates the executing program is in page 1, from 10000H-1FFFFH

P1 PINS STATUS

(initial=00H)

Bit:	7	6	5	4	3	2	1	0
	P1.7SR	P1.6SR	P1.5SR	P1.4SR	P1.3SR	P1.2SR	P1.1SR	P1.0SR

Mnemonic: P1SR

Address: 93h

P1SR: Set when a falling edge is detected on the corresponding P1 pin, clear by software.

W925EP01/ W925EP01FG



P0 I/O PORT CONTROL

(initial=FFH, input mode)

Bit:	7	6	5	4	3	2	1	0
	P0.7IO	P0.6IO	P0.5IO	P0.4IO	P0.3IO	P0.2IO	P0.1IO	P0.0IO

Mnemonic: P0IO

Address: 94h

P0IO: P0 pins I/O control.

1: input mode

0: output mode

P1 I/O PORT CONTROL

(initial=FFH, input mode)

Bit:	7	6	5	4	3	2	1	0
	P1.7IO	P1.6IO	P1.5IO	P1.4IO	P1.3IO	P1.2IO	P1.1IO	P1.0IO

Mnemonic: P1IO

Address: 95h

P1IO: P1 pins I/O control.

1: input mode

0: output mode

P2 I/O PORT CONTROL

(initial=FFH, input mode)

Bit:	7	6	5	4	3	2	1	0
	P2.7IO	P2.6IO	P2.5IO	P2.4IO	P2.3IO	P2.2IO	P2.1IO	P2.0IO

Mnemonic: P2IO

Address: 96h

P2IO: P2 pins I/O control.

1: input mode

0: output mode

P3 I/O PORT CONTROL

(initial=FFH, input mode)

Bit:	7	6	5	4	3	2	1	0
	P3.7IO	P3.6IO	P3.5IO	P3.4IO	P3.3IO	P3.2IO	P3.1IO	P3.0IO

Mnemonic: P3IO

Address: 97h

P3IO: P3 pins I/O control.

1: input mode

0: output mode

W925EP01/ W925EP01FG



SERIAL PORT0 CONTROL

(initial=00H)

Bit:	7	6	5	4	3	2	1	0
	SM0/FE	SM1	SM2	REN	TB8	RB8	TI	RI

Mnemonic: SCON

Address: 98h

SM0/FE: Serial port0, Mode 0 bit or Framing Error Flag: The SMOD0 bit in PCON SFR determines whether this bit acts as SM0 or as FE. The operation of SM0 is described below. When used as FE, this bit will be set to indicate an invalid stop bit. This bit must be manually cleared in software to clear the FE condition.

SM1: Serial port0 Mode bit 1:

SM0	SM1	Mode	Description	Length	Baud rate
0	0	0	Synchronous	8	4/12 Tclk
0	1	1	Asynchronous	10	variable
1	0	2	Asynchronous	11	16/32 Tclk
1	1	3	Asynchronous	11	variable

SM2: In mode 2 or 3, if SM2 is set to 1, then RI will not be activated if the received 9th data bit (RB8) is 0. In mode 0 and 1, bit SM2 can be changed by software. In mode 1, if SM2 = 1, then RI will not be activated if a valid stop bit was not received. In mode 0, the SM2 bit controls the serial port0 clock.

REN: Receive enable. When set to 1 serial reception is enabled, otherwise reception is disabled.

TB8: This is the 9th bit to be transmitted in modes 2 and 3. This bit is set and cleared by software as desired.

RB8: In modes 2 and 3 this is the received 9th data bit. In mode 1, if SM2 = 0, RB8 is the stop bit that was received. In mode 0 it has no function.

TI: Transmit interrupt flag: This flag is set by hardware at the end of the 8th bit time in mode 0, or at the beginning of the stop bit in all other modes during serial transmission. **This bit must be cleared by software.**

RI: Receive interrupt flag: This flag is set by hardware at the end of the 8th bit time in mode 0, or halfway through the stop bits time in the other modes during serial reception. However the restrictions of SM2 apply to this bit. **This bit can be cleared only by software.**

SERIAL DATA BUFFER

(initial=XXH) Read Only

Bit:	7	6	5	4	3	2	1	0
	SBUF.7	SBUF.6	SBUF.5	SBUF.4	SBUF.3	SBUF.2	SBUF.1	SBUF.0

Mnemonic: SBUF

Address: 99h

SBUF.7-0: Serial data on the serial port0 is read from or written to this location. It actually consists of two separate internal 8-bit registers. One is the receive register, and the other is the transmit buffer. Any read access gets data from the receive data buffer, while write access is to the transmit data buffer.

W925EP01/ W925EP01FG



P1 PINS INTERRUPT EABLE

(initial=00H)

Bit:	7	6	5	4	3	2	1	0
	P1.7EF	P1.6EF	P1.5EF	P1.4EF	P1.3EF	P1.2EF	P1.1EF	P1.0EF

Mnemonic: P1EF

Address: 9Bh

P1EF: P1 pins interrupt function enabled/disabled register

0: disable

1: enable

P1 PULL-HIGH CONTROL

(initial=00H)

Bit:	7	6	5	4	3	2	1	0
	P1.7H	P1.6H	P1.5H	P1.4H	P1.3H	P1.2H	P1.1H	P1.0H

Mnemonic: P1H

Address: 9Dh

P1H: Port1 pins pull-high resistor enable/disable

1: enable

0: disable

P2 PULL-HIGH CONTROL

(initial=00H)

Bit:	7	6	5	4	3	2	1	0
	P2.7H	P2.6H	P2.5H	P2.4H	P2.3H	P2.2H	P2.1H	P2.0H

Mnemonic: P2H

Address: 9Eh

P2H: Port2 pins pull-high resistor enable/disable

1: enable

0: disable

P3 PULL-HIGH CONTROL

(initial=00H)

Bit:	7	6	5	4	3	2	1	0
	P3.7H	P3.6H	P3.5H	P3.4H	P3.3H	P3.2H	P3.1H	P3.0H

Mnemonic: P3H

Address: 9Fh

P3H: Port3 pins pull-high resistor enable/disable

1: enable

0: disable

PORT 2

(initial=FFH)

Bit:	7	6	5	4	3	2	1	0
	P2.7	P2.6	P2.5	P2.4	P2.3	P2.2	P2.1	P2.0

Mnemonic: P2

Address: A0h

W925EP01/ W925EP01FG



P2.7-0: Port 2 is an I/O port with internal pull-high resistor. P2 can be selected as input or output mode by the P2IO register. At initial reset, P2 is used as input mode. When P2IO is set to 0, P2 is used as CMOS output mode.

HIGH BYTE REGISTER

(initial=00H)

Bit:	7	6	5	4	3	2	1	0
	HB.7	HB.6	HB.5	HB.4	HB.3	HB.2	HB.1	HB.0

Mnemonic: HB

Address: A1h

This register contains the high byte address during execution of "MOVX @Ri," instructions.

P4 PULL-HIGH CONTROL

(initial=00H)

Bit:	7	6	5	4	3	2	1	0
	P4.7H	P4.6H	P4.5H	P4.4H	P4.3H	P4.2H	P4.1H	P4.0H

Mnemonic: P4H

Address: A2h

P4H: Port4 pins pull-high resistor enable/disable

1: enable

0: disable

P5 PULL-HIGH CONTROL

(initial=00H)

Bit:	7	6	5	4	3	2	1	0
	P5.7H	P5.6H	P5.5H	P5.4H	P5.3H	P5.2H	P5.1H	P5.0H

Mnemonic: P5H

Address: A3h

P5H: Port5 pins pull-high resistor enable/disable

1: enable

0: disable

PORT 7

(initial=FFH)

Bit:	7	6	5	4	3	2	1	0
	P7.7	P7.6	P7.5	P7.4	P7.3	P7.2	P7.1	P7.0

Mnemonic: P7

Address: A4h

P7.7-0: Port 7 is an I/O port with internal pull-high resistor. P7 can be selected as input or output mode by the P7IO register, at initial reset, P7IO is set to 1, P7 is used as input mode. When P7IO is set to 0, P7 is used as CMOS output mode.

The special function of P7 is as data bus of external program ROM or external data RAM.

The program memory on the standard 8052 can only be addressed to 64KB long. W925EP01 can extend to two 64KB program ROM banks; there are on-chip APROM bank and external program ROM bank. When PG=1, the P7 pins can be treated as data bus of external program ROM. When PG=0, the P7 pins can be treated as normal I/O.

W925EP01/ W925EP01FG



When “MOVC A, @A+DPTR” is executed to read the external ROM data or “MOVX dest, src” is executed to access the external data RAM, the P7 pins can be treated as data bus of external data storages.

P7 inputs the data <7:0> of the external ROM. Or, P7 inputs/outputs the data <7:0> of the external data RAM.

PORT 6

(initial=FFH)

Bit:	7	6	5	4	3	2	1	0
	P6.7	P6.6	P6.5	P6.4	P6.3	P6.2	P6.1	P6.0

Mnemonic: P6

Address: A5h

P6.7-0: Port 6 is an I/O port with internal pull-high resistor. P6 can be selected as input or output mode by the P6IO register, at initial reset, P6IO is set to 1, P6 is used as input mode. When P6IO is set to 0, P6 is used as CMOS output mode.

The special function of P6 is as address bus of external program ROM or external data RAM.

The program memory on the standard 8052 can only be addressed to 64KB long. W925EP01 can extend to two 64KB program ROM banks; there are on-chip APROM bank and external program ROM bank. When PG=1, the P6 pins can be treated as address high bus of external program ROM. When PG=0, the P6 pins can be treated as normal I/O.

When “MOVC A, @A+DPTR” is executed to read the external ROM data or “MOVX dest, src” is executed to access the external data RAM, the P6 pins can be treated as address high bus of external data storages.

PORT 4

(initial=FFH)

Bit:	7	6	5	4	3	2	1	0
	P4.7	P4.6	P4.5	P4.4	P4.3	P4.2	P4.1	P4.0

Mnemonic: P4

Address: A6h

P4.7-0: Port 4 is an I/O port with internal pull-high resistor. P4 can be selected as input or output mode by the P4IO register. At initial reset, P4IO is set to 1; P4 is used as input mode. When P4IO is set to 0, P4 is used as CMOS output mode. Special function of P4 is described below.

P4.7-5	I/O	Normal I/O
P4.4	VPOS	Positive input of the comparator
P4.3	I/O	Normal I/O
P4.2	VNEG	Negative input of the comparator
P4.1	SDATA1	Serial port1 data I/O
P4.0	SCLK1	Serial port1 clock I/O with Smith trigger in input path

W925EP01/ W925EP01FG



PORT 5

(initial=FFH)

Bit:	7	6	5	4	3	2	1	0
	P5.7	P5.6	P5.5	P5.4	P5.3	P5.2	P5.1	P5.0

Mnemonic: P5

Address: A7h

P5.7-0: Port 5 is an I/O port with internal pull-high resistor. P5 can be selected as input or output mode by the P5IO register, at initial reset, P5IO is set to 1, P5 is used as input mode. When P5IO is set to 0, P5 is used as CMOS output mode.

The special function of P5 is as address bus of external program ROM or external data RAM.

The program memory on the standard 8052 can only be addressed to 64KB long. W925EP01 can extend to two 64KB program ROM banks, there are on-chip APROM bank and external program ROM bank. When PG=1, the P5 pins can be treated as address high bus of external program ROM. When PG=0, the P5 pins can be treated as normal I/O.

When "MOVC A, @A+DPTR" is executed to read the external ROM data or "MOVX dest, src" is executed to access the external data RAM, the P5 pins can be treated as address high bus of external data storages.

INTERRUPT ENABLE

(initial=00H)

Bit:	7	6	5	4	3	2	1	0
	EA	ES1	-	ES0	ET1	EX1	ET0	EX0

Mnemonic: IE

Address: A8h

EA: Global enable. Enable/disable all interrupts.

ES1: Enable Serial port1 interrupt

ES0: Enable Serial port0 interrupt

ET1: Enable Timer 1 interrupt

EX1: Enable external interrupt 1

ET0: Enable Timer 0 interrupt

EX0: Enable external interrupt 0

P6 PULL-HIGH CONTROL

(initial=00H)

Bit:	7	6	5	4	3	2	1	0
	P6.7H	P6.6H	P6.5H	P6.4H	P6.3H	P6.2H	P6.1H	P6.0H

Mnemonic: P6H

Address: AAh

P6H: Port6 pins pull-high resistor enable/disable

1: enable

0: disable

W925EP01/ W925EP01FG



P7 PULL-HIGH CONTROL

(initial=00H)

Bit:	7	6	5	4	3	2	1	0
	P7.7H	P7.6H	P7.5H	P7.4H	P7.3H	P7.2H	P7.1H	P7.0H

Mnemonic: P7H

Address: ABh

P7H: Port7 pins pull-high resistor enable/disable

1: enable

0: disable

P7 I/O PORT CONTROL

(initial=FFH, input mode)

Bit:	7	6	5	4	3	2	1	0
	P7.7IO	P7.6IO	P7.5IO	P7.4IO	P7.3IO	P7.2IO	P7.1IO	P7.0IO

Mnemonic: P7IO

Address: ACh

P7IO: P7 pins I/O control.

1: input mode

0: output mode

P6 I/O PORT CONTROL

(initial=FFH, input mode)

Bit:	7	6	5	4	3	2	1	0
	P6.7IO	P6.6IO	P6.5IO	P6.4IO	P6.3IO	P6.2IO	P6.1IO	P6.0IO

Mnemonic: P6IO

Address: ADh

P6IO: P6 pins I/O control.

1: input mode

0: output mode

P4 I/O PORT CONTROL

(initial=FFH, input mode)

Bit:	7	6	5	4	3	2	1	0
	P4.7IO	P4.6IO	P4.5IO	P4.4IO	P4.3IO	P4.2IO	P4.1IO	P4.0IO

Mnemonic: P4IO

Address: AEh

P4IO: P4 pins I/O control.

1: input mode

0: output mode



P5 I/O PORT CONTROL

(initial=FFH, input mode)

Bit:	7	6	5	4	3	2	1	0
	P5.7IO	P5.6IO	P5.5IO	P5.4IO	P5.3IO	P5.2IO	P5.1IO	P5.0IO

Mnemonic: P5IO

Address: AFh

P5IO: P5 pins I/O control.

1: input mode

0: output mode

PORT 3

(initial=FFH)

Bit:	7	6	5	4	3	2	1	0
	P3.7	P3.6	P3.5	P3.4	P3.3	P3.2	P3.1	P3.0

Mnemonic: P3

Address: B0h

P3.7-0: P3 can be selected as input or output mode by the P3IO register, at initial reset, P3IO is set to 1, P3 is used as input mode. When P3IO is set to 0, the P3 is used as CMOS output mode. Special function of P3 is described below.

P3.7	\overline{RD}	Read low pulse signal when reading external RAM
P3.6	\overline{WR}	Write low pulse signal when writing external RAM
P3.5	T1	Timer/counter 1 external count input
P3.4	T0	Timer/counter 0 external count input
P3.3	$\overline{INT1}$	External interrupt 1
P3.2	$\overline{INT0}$	External interrupt 0
P3.1	TxD	Serial port0 output
P3.0	RxD	Serial port0 input

CID REGISTER

(initial=00H, read only)

Bit:	7	6	5	4	3	2	1	0
	-	FCLK	FDATA	FCD	DTMFD	FDR	ALGO	RNG

Mnemonic: CIDR

Address: B1h

This SFR indicates the CID signal immediately. Register data is set or cleared by hardware only.

FCLK: FSK serial clock with the baud rate of 1200Hz.

FDATA: FSK serial bit data.

FCD: Set when FSK carrier is detected. Cleared when FSK carrier is disappeared.

DTMFD: Set when DTMF decoded data is ready. Cleared when DTMF signal ends.

FDR: Set when FSK 8 bits data is ready. Cleared before next FSK start bit comes

ALGO: Dual tone Alert signal Guard time detect signal. Set when a guard time qualified dual tone alert signal has been detected. Cleared when the guard time qualified dual tone alert signal is absent.

W925EP01/ W925EP01FG



RNG: Ring detection bit. High will be indicated the detection of line reversal and/or ringing.

CID FLAG GENERATOR

(initial=00H)

Bit:	7	6	5	4	3	2	1	0
	-	-	-	FSF	DTMFDF	FDRF	ALGOF	RNGF

Mnemonic: CIDFG

Address: B2h

FSF: Set when FSK Latch clock low to high. Cleared by software

DTMFDF: Set when DTMFD low to high. Cleared by software

FDRF: Set when FDR low to high. Cleared by software.

ALGOF: Set when ALGO low to high. Cleared by software.

RNGF: Set when RNG low to high. Cleared by software.

CID POWER CONTROL REGISTER

(initial=00H)

Bit:	7	6	5	4	3	2	1	0
	-	-	-	CIDE	-	FSKE	CASE	DTMFE

Mnemonic: CIDPCR

Address: B3h

CIDE: Global enable CID function. Low to disable all functions of CID parts.

FSKE: Enable FSK demodulation circuit.

CASE: Enable Dual Tone Alert Signal detection circuit.

DTMFE: Enable DTMF demodulation circuit.

FSK DATA REGISTER

(initial=XXH)

Bit:	7	6	5	4	3	2	1	0
	FD7	FD6	FD5	FD4	FD3	FD2	FD1	FD0

Mnemonic: FSKDR

Address: B4h

FD7-0: 8 bits FSK demodulated data.

DTMF DATA REGISTER

(initial=XXH)

Bit:	7	6	5	4	3	2	1	0
	CASH	CASL	DTMFH	DTMFL	DD3	DD2	DD1	DD0

Mnemonic: DTMFDR

Address: B5h

CASH: Set when Dual Tone Alert Signal high tone is detected.

CASL: Set when Dual Tone Alert Signal low tone is detected.

DTMFH: Set when DTMF high tone is detected.

DTMFL: Set when DTMF low tone is detected.

DD3-0: 4 bits DTMF demodulated data.



DTMF PRESENT TIME REGISTER

(initial=19H)

Bit:	7	6	5	4	3	2	1	0
	DPT7	DPT6	DPT5	DPT4	DPT3	DPT2	DPT1	DPT0

Mnemonic: DTMFPT

Address: B6h

The clock period of guard-time timer is 0.8582mS. The default DTMF present time is 21.45mS.

DPT7-0: The pre-set data register for counting DTMF present time. When DTMF is detected (EST, low to high), the guard timer starts to up-count from 00H. As the guard timer is equal to the value of DTMFPT, while exist of the DTMF is accepted. EST changes to low state to stop and reset the counter.

DTMF ABSENT TIME REGISTER

(initial=19H)

Bit:	7	6	5	4	3	2	1	0
	DAT7	DAT6	DAT5	DAT4	DAT3	DAT2	DAT1	DAT0

Mnemonic: DTMFAT

Address: B7h

The clock period of guard-time timer is 0.8582mS. The default DTMF absent time is 21.45mS.

DAT7-0: The pre-set data register for counting DTMF absent time. When DTMF is absent (EST, high to low), the guard timer starts to up-count from 00H. As the guard timer is equal to the value of DTMFAT, the finish of DTMF is recognized. EST changes to low state to stop and reset the counter.

INTERRUPT PRIORITY

(initial=00H)

Bit:	7	6	5	4	3	2	1	0
	-	PS1	-	PS0	PT1	PX1	PT0	PX0

Mnemonic: IP

Address: B8h

IP.7: This bit is un-implemented and will read high.

PS1: This bit defines the Serial port1 interrupt priority. PS1 = 1 sets it to higher priority level.

PS0: This bit defines the Serial port0 interrupt priority. PS0 = 1 sets it to higher priority level.

PT1: This bit defines the Timer 1 interrupt priority. PT1 = 1 sets it to higher priority level.

PX1: This bit defines the External interrupt 1 priority. PX1 = 1 sets it to higher priority level.

PT0: This bit defines the Timer 0 interrupt priority. PT0 = 1 sets it to higher priority level.

PX0: This bit defines the External interrupt 0 priority. PX0 = 1 sets it to higher priority level.

DTMF AND CAS GENERATOR REGISTER

(initial=00H)

Bit:	7	6	5	4	3	2	1	0
	CASGE	DTGE	HE	LE	L1	L0	H1	H0

Mnemonic: DTMFG

Address: BAh

CASGE: Enable CAS tone output to DTMF pin.

DTGE: Enable dual tone output to DTMF pin.

W925EP01/ W925EP01FG



HE: Enable CAS/DTMF high group frequency output.

LE: Enable CAS/DTMF low group frequency output.

L1	L0	H1	H0	SELECTED TONE	HE	LE	CAS SELECTED TONE
x	X	0	0	1209Hz	0	0	Low
x	X	0	1	1336Hz	0	1	2130Hz
x	X	1	0	1477Hz	1	0	2750Hz
x	X	1	1	1633Hz	1	1	2130Hz & 2750Hz
0	0	x	X	697Hz			
0	1	x	X	770Hz			
1	0	x	X	852Hz			
1	1	x	X	941Hz			

COMPARATOR REGISTER

(initial=00H)

Bit:	7	6	5	4	3	2	1	0
	-	-	-	-	RESC	-	-	COMPEN

Mnemonic: COMPR

Address: BBh

RESC: Result of the comparator. Set when positive analog input voltage is (VPOS) higher than negative analog input voltage (VNEG) RESC is a read only bit.

COMPEN: COMPEN=0 Disable comparator
COMPEN=1 Enable comparator

IDLE RELEASED CONDITION REGISTER 1

(initial=00H)

Bit:	7	6	5	4	3	2	1	0
	-	IRCS1	-	IRCS1	IRCT1	IRCX1	IRCT0	IRCX0

Mnemonic: IRC1

Address: BCh

One of the bits of IRC1 and IRC2 will be set by hardware to record the idle released condition when the idle mode is released. IRC1 and IRC2 can be set by hardware and can be R/W by software.

IRCS1: Idle mode released by Serial port1 interrupt flag.

IRCS0: Idle mode released by Serial port0 interrupt flag.

IRCT1: Idle mode released by Timer1 interrupt flag.

IRCX1: Idle mode released by external interrupt 1 flag.

IRCT0: Idle mode released by Timer0 interrupt flag.

W925EP01/ W925EP01FG



IRCX0: Idle mode released by external interrupt 0 flag.

IDLE RELEASED CONDITION REGISTER 2

(initial=00H)

Bit:	7	6	5	4	3	2	1	0
	-	-	IRCWDI	IRCCOMP	IRCDIV	IRCCID	IRCX3	IRCX2

Mnemonic: IRC2

Address: BDh

One of the bits of IRC1 and IRC2 will be set by hardware to record the idle released condition when the idle mode is released. IRC1 and IRC2 can be set by hardware and can be R/W by software.

IRCWDI: Idle mode released by Watchdog timer interrupt flag.

IRCCOMP: Idle mode released by comparator interrupt flag.

IRCDIV: Idle mode released by Divider interrupt flag.

IRCCID: Idle mode released by CID interrupt flag.

IRCX3: Idle mode released by External Interrupt 3 flag.

IRCX2: Idle mode released by External Interrupt 2 flag.

CAS TONE PRESENT TIME REGISTER

(initial=0FH)

Bit:	7	6	5	4	3	2	1	0
	CASPT7	CASPT6	CASPT5	CASPT4	CASPT3	CASPT2	CASPT1	CASPT0

Mnemonic: CASPT

Address: BEh

The clock period of guard-time timer is 0.8582mS. The initial alert tone present time is 12.87mS.

CASPT7-0: The pre-set data register for counting CAS tone present time. When CAS tone is detected (ALGR: low to high), the guard timer starts to up-count from 00H. As the guard timer is equal to the value of CASPT, the existence of the CAS tone is accepted. ALGR changes to low state to stop and reset the counter.

CAS TONE ABSENT TIME REGISTER

(initial=0FH)

Bit:	7	6	5	4	3	2	1	0
	CASAT7	CASAT6	CASAT5	CASAT4	CASAT3	CASAT2	CASAT1	CASAT0

Mnemonic: CASAT

Address: BFh

The clock period of guard-time timer is 0.8582mS. The initial alert tone absent time is 12.87mS.

CASAT7-0: The pre-set data register for counting CAS tone absent time. When CAS tone is absent (ALGR: high to low), the guard timer starts to up-count from 00H. As the guard timer is equal to the value of CASAT, the finish of CAS tone is recognized. ALGR changes to high state to stop and reset the counter.

SERIAL PORT CONTROL 1

(initial=00H)

Bit:	7	6	5	4	3	2	1	0
	SF1	-	REGON	REN1	SFQ	SEDG	CLKIO	SIO

Mnemonic: SCON1

Address: C0h



- SF1: Serial port1 interrupt flag. When 8-bits data transited completely, SF1 is set by hardware. SF1 is cleared when serial interrupt routine is executed or cleared by software.
- REGON: Regulator on/off control. 0 will disable regulator, 1 will enable regulator.
- REN1: Set REN1 from 0 to 1 to start the serial port to receive 8-bit serial data.
- SFQ: SFQ=0 Serial clock output frequency is equal to Fosc /2
SFQ=1 Serial clock output frequency is equal to Fosc /256
- SEDG: SEDG=0 Serial data latched at falling edge of clock, SCLK=Low initially.
SEDG=1 Serial data latched at rising edge of clock, SCLK=High initially
- CLKIO: CLKIO=0 P4.0 (SCLK) work as output mode
CLKIO=1 P4.0 (SCLK) work as input mode
- SIO: SIO=0 P4.0 & P4.1 work as normal I/O pin
SIO=1 P4.0 & P4.1 work as Serial port1 function

SERIAL DATA BUFFER 1

(initial=00H) **Read Only**

Bit:	7	6	5	4	3	2	1	0
	SBUF1.7	SBUF1.6	SBUF1.5	SBUF1.4	SBUF1.3	SBUF1.2	SBUF1.1	SBUF1.0

Mnemonic: SBUF1

Address: C1h

SBUF1.7-0: Serial data on the serial port1 is read from or written to this location. It actually consists of two separate internal 8-bit registers. One is the receive register, and the other is the transmit buffer. Any read access gets data from the receive data buffer, while write access is to the transmit data buffer.

POWER MANAGEMENT REGISTER

(initial=10000XX1B)

Bit:	7	6	5	4	3	2	1	0
	XT/ \overline{RG}	RGMD	RGS�	X2OFF	X1OFF	-	-	DME0

Mnemonic: PMR

Address: C4h

XT/ \overline{RG} : Crystal/RC Oscillator Select. Setting this bit selects crystal or external clock as system clock source. Clearing this bit selects the on-chip RC oscillator as clock source. X1UP (STATUS.4) must be set to 1 and X1OFF (PMR.3) must be cleared before this bit can be set. Attempts to set this bit without obeying these conditions will be ignored.

RGMD: RC Mode Status. This bit indicates the current clock source of micro-controller. When it is cleared, CPU is operating from the external crystal or oscillator. When it is set, CPU is operating from the on-chip RC oscillator.

RGS�: RC Oscillator Select. This bit selects the clock source following a resume from Power Down Mode. Setting this bit allows device operating from RC oscillator when a resume from Power down Mode. When this bit is cleared, the device will hold operation until the crystal oscillator has warmed-up following a resume from Power down Mode.

X2OFF: Set to disable sub-oscillator (32 KHz oscillator)

X1OFF: Crystal Oscillator Disable. Setting this bit disables the external crystal oscillator. This bit can only be set to 1 while the micro-controller is operating from the RC oscillator. Clearing this bit

W925EP01/ W925EP01FG



restarts the crystal oscillator, the X1UP (STATUS.4) bit will be set after crystal oscillator warmed-up has completed.

DME0: This bit determines the on-chip MOVX SRAM to be enabled or disabled. Set this bit to 1(default) will enable the on-chip 4K bytes MOVX SRAM. Clear this bit to 0 will disable the on-chip 4K bytes MOVX SRAM.

The W925EP01 contains on-chip 4K MOVX SRAM of Data Memory, which can only be accessed by MOVX instructions from the address 000H to FFFH. Access to the on-chip MOVX SRAM is optional by software setting DME0, MOVX addresses greater than FFFH automatically go to external memory through A0 to A15; this is the default condition. When DME0 be clearing, the 4K data memory area is transparent to the system memory map. Any MOVX directed to the space between 0000H to FFFFH goes to expanded bus on A0 to A15.

STATUS REGISTER

(initial=00H)

Bit:	7	6	5	4	3	2	1	0
	X2UP	HIP	LIP	X1UP	-	-	-	-

Mnemonic: STATUS

Address: C5h

X2UP: Sub-crystal oscillator warm-up status. When set, this bit indicates the crystal oscillator has completed the warm-up delay. When X2OFF bit is set, hardware will clear this bit. There are two options which are selected by option code for warm-up delay, one is 1024 clocks warm-up delay, and other is 65536 clocks warm-up delay.

HIP: High Priority Interrupt Status. When set, it indicates that software is servicing a high priority interrupt. This bit will be cleared when the program executes the corresponding RETI instruction.

LIP: Low Priority Interrupt Status. When set, it indicates that software is servicing a low priority interrupt. This bit will be cleared when the program executes the corresponding RETI instruction.

X1UP: Crystal Oscillator Warm-up Status. When set, this bit indicates the crystal oscillator has completed the 65536 clocks warm-up delay. Each time the crystal oscillator is restarted by exit from power down mode or the X1OFF bit is set, hardware will clear this bit. This bit is set to 1 after a power-on reset. When this bit is cleared, it prevents software from setting the XT/ \overline{RG} bit to enable CPU operation from crystal oscillator. There are two options which are selected by option code for warm-up delay, one is 4096 clocks warm-up delay, and other is 65536 clocks warm-up delay.

FSK TRANSIMT CONTROL REGISTER

(initial=00H)

Bit:	7	6	5	4	3	2	1	0
	FTE	FTM	FDS	-	-	-	LO1	LO0

Mnemonic: FSKTC

Address: C6h

FTE: FSK transmit Enable; Enable=1, Disable=0

FTM: FSK signal Standard; Bellcore=1, V.23=0

FDS: FSK data sending status

LO0, LO1: CAS/FSK transmitting level option. In CAS tone, it just is suitable for 2130Hz. The output levels of 2750Hz will higher 2dBm than it.

W925EP01/ W925EP01FG



FSK output level	LO1	LO0
150mV	0	0
125mV	0	1
100mV	1	0
75mV	1	1

FSK TRANSMIT DATA BUFFER

(initial=00H)

Bit:	7	6	5	4	3	2	1	0
	-	-	-	-	-	-	-	FSKTB.0

Mnemonic: FSKTB

Address: C7h

FSKTB.0: Only this bit will be latched and send out as FSK signal

DIVIDER CONTROL

(initial = 01H)

Bit:	7	6	5	4	3	2	1	0
	-	-	-	-	-	-	-	DIVA

Mnemonic: DIVC

Address: C8h

DIVA: Divider available control bit. This bit is set or cleared by software to enable/disable divider. DIVA = 1 to enable the divider. DIVA = 0 to disable the divider. DIVA is reset after reset.

BAUD RATE GENERATOR CONTROL REGISTER

(initial=00000110B)

Bit:	7	6	5	4	3	2	1	0
	-	-	-	-	-	RCKEN	TCKEN	BGEN

Mnemonic: BGCON

Address: CEh

BGEN: BG-Counter control bit. Enable/Disable baud rate generator counter. 0: Disable; 1: Enable.

TCKEN: Select the transmission clock source of serial port0. When TCKEN=1, the clock source come from the BG-counter; otherwise, the clock source come from Timer0 or Timer1.

RCKEN: Select the receiving clock source of serial port0. When RCKEN=1, the clock source come from the BG-counter; otherwise, the clock source come from Timer0 or Timer1.

BAUD RATE GENERATOR RELOAD REGISTER

(initial=1AH for 9600 baud rate of serial port0)

Bit:	7	6	5	4	3	2	1	0
	BG.7	BG.6	BG.5	BG.4	BG.3	BG.2	BG.1	BG.0

Mnemonic: BG

Address: CFh

W925EP01/ W925EP01FG



BG: Move the proper value into this register for generating the baud rate of serial port0. When BG-Counter is overflow, the content of BG will be reloaded into the BG-Counter.

The baud rate of serial port0 is generated by $F_m/BG/16$.

Example: if $F_m=4\text{MHz}$ and the content of BG is 1Ah (initial value), the baud rate = $4000000/26/16 = 9615\text{Hz}$;

if the content of BG is changed to 0Dh, the baud rate should be $4000000/13/16 = 19230\text{Hz}$.

PROGRAM STATUS WORD

(initial=00H)

Bit:	7	6	5	4	3	2	1	0
	CY	AC	F0	RS1	RS0	OV	F1	P

Mnemonic: PSW

Address: D0h

CY: Carry flag. Set for an arithmetic operation, which results in a carry being generated from the ALU. It is also used as the accumulator for the bit operations.

AC: Auxiliary carry. Set when the previous operation resulted in a carry from the high order nibble.

F0: User flag 0: General purpose flag. That can be set or cleared by the user.

RS.1-0: Register bank selection bits:

RS1	RS0	REGISTER BANK	ADDRESS
0	0	0	00-07h
0	1	1	08-0Fh
1	0	2	10-17h
1	1	3	18-1Fh

OV: Overflow flag. Set when a carry was generated from the seventh bit but not from the 8th bit as a result of the previous operation, or vice-versa.

F1: User Flag 1: General purpose flag. That can be set or cleared by the user by software.

P: Parity flag. Set/cleared by hardware to indicate odd/even number of 1's in the accumulator.

WATCHDOG CONTROL

(initial: note)

Bit:	7	6	5	4	3	2	1	0
	-	POR	-	WFS	WDIF	WTRF	EWT	RWT

Mnemonic: WDCON

Address: D8h

POR: Power-on reset flag. Hardware will set this flag when system is powered on and this flag is cleared only by software.

WFS: Watchdog Timer Frequency Select. Set to select F_s as WDT clock input. Clear to select F_{osc} as WDT clock input.

WDIF: Watchdog Timer Interrupt flag. This bit is set whenever the time-out occurs in the watchdog timer. If the Watchdog interrupt is enabled (EIE.5), then an interrupt will occur (if the global interrupt enable is set and other interrupt requirements are met). Software or any reset can clear this bit.

W925EP01/ W925EP01FG



WTRF: Watchdog Timer Reset Flag. Hardware will set this bit when the watchdog timer causes a reset. Software can read it but must clear it manually. A power-fail reset will also clear the bit. This bit helps software in determining the cause of a reset. If EWT = 0, the watchdog timer will have no effect on this bit.

EWT: Enable Watchdog timer Reset. Setting this bit will enable the Watchdog timer Reset function.

RWT: Reset Watchdog Timer. This bit helps in putting the watchdog timer into a known state. It also helps in resetting the watchdog timer before a time-out occurs. Failing to set the EWT before time-out will cause an interrupt, if EWDI (EIE.5) is set, and 512 clocks after that a watchdog timer reset will be generated if EWT is set. This bit is self-clearing by hardware.

Note:

The WDCON SFR is set to a 0x000xx0b on an external reset. WTRF is set to a 1 on a Watchdog timer reset, but to a 0 on power on/down resets. WTRF is not altered by an external reset. POR is set to 1 by a power-on reset. EWT is set to 0 on a Power-on reset and unaffected by other resets.

ACCUMULATOR

(initial=00H)

Bit:	7	6	5	4	3	2	1	0
	ACC.7	ACC.6	ACC.5	ACC.4	ACC.3	ACC.2	ACC.1	ACC.0
Mnemonic:	ACC						Address: E0h	

ACC.7-0: The ACC register.

ISP ADDRESS LOW BYTE

(INITIAL=00H)

Bit:	7	6	5	4	3	2	1	0
	A7	A6	A5	A4	A3	A2	A1	A0
Mnemonic:	SFRAL						Address: E4h	

The low byte destination address is for In System Programming operations. The SFRAH and SFRAL address register are specific ROM bytes for erasure, programming or read.

ISP ADDRESS HIGH BYTE

(INITIAL=00H)

Bit:	7	6	5	4	3	2	1	0
	A15	A14	A13	A12	A11	A10	A9	A8
Mnemonic:	SFRAH						Address: E5h	

The high byte destination address is for In System Programming operations. The SFRAH and SFRAL address are specific ROM bytes for erasure, programming or read.

ISP DATA BUFFER

(INITIAL=FFH)

Bit:	7	6	5	4	3	2	1	0
	D7	D6	D5	D4	D3	D2	D1	D0
Mnemonic:	SFRFD						Address: E6h	

In ISP mode, read/write a specific byte ROM content must go through SFRFD register.

W925EP01/ W925EP01FG



ISP OPERATION MODES

(INITIAL=3FH)

Bit:	7	6	5	4	3	2	1	0
	-	WFWIN	OEN	CEN	CTRL3	CTRL2	CTRL1	CTRL0

Mnemonic: SFRCN

Address: E7h

WFWIN: Destination ROM bank for programming, erasure and read. 0 = AP FLASH EPROM, 1 = LD FLASH EPROM.

OEN: Flash EPROM output enable.

CEN: Flash EPROM chip enable.

CTRL [3:0]: Mode Selection.

MODE	WFWIN	OEN	CEN	CTRL<3:0>	SFRAH, SFRAL	SFRFD
Erase 64KB APROM	0	1	0	0010	X	X
Program 64KB APROM	0	1	0	0001	Address in	Data in
Read 64KB APROM	0	0	0	0000	Address in	Data out
Erase 4KB LDROM	1	1	0	0010	X	X
Program 4KB LDROM	1	1	0	0001	Address in	Data in
Read 4KB LDROM	1	0	0	0000	Address in	Data out

EXTENDED INTERRUPT ENABLE

(initial=00H)

Bit:	7	6	5	4	3	2	1	0
	-	-	EWDI	ECOMP	EDIV	ECID	EX3	EX2

Mnemonic: EIE

Address: E8h

EIE.7-6: Reserved bits.

EWDI: Enable Watchdog timer interrupt.

ECOMP: Enable comparator interrupt.

EDIV: Enable Divider interrupt.

ECID: Enable CID interrupt.

EX3: External Interrupt 3 Enable.

EX2: External Interrupt 2 Enable.

TIMED ACCESS

(INITIAL=FFH)

Bit:	7	6	5	4	3	2	1	0
	TA.7	TA.6	TA.5	TA.4	TA.3	TA.2	TA.1	TA.0

Mnemonic: TA

Address: EEh

W925EP01/ W925EP01FG



EXTENDED INTERRUPT PRIORITY

(initial=00H)

Bit:	7	6	5	4	3	2	1	0
	-	-	PWDI	PCOMP	PDIV	PCID	PX3	PX2

Mnemonic: EIP

Address: F8h

PWDI: Watchdog timer interrupt priority. 0 = Low priority, 1 = High priority.

PCOMP: Comparator interrupt priority. 0 = Low priority, 1 = High priority.

PDIV: Divider Interrupt Priority. 0 = Low priority, 1 = High priority.

PCID: CID Interrupt Priority. 0 = Low priority, 1 = High priority.

PX3: External Interrupt 3 Priority. 0 = Low priority, 1 = High priority.

PX2: External Interrupt 2 Priority. 0 = Low priority, 1 = High priority.

CID GAIN CONTROL DATA

(initial=00H)

Bit:	7	6	5	4	3	2	1	0
	BIT7	BIT6	BIT5	BIT4	BIT3	BIT2	BIT1	BIT0

Mnemonic: CIDGD

Address: F9h

CIDGD.7-0: The data value of programmable CID input filter gain and hysteresis.

CID GAIN CONTROL ADDRESS

(initial=00H)

Bit:	7	6	5	4	3	2	1	0
	-	-	-	-	BIT3	BIT2	BIT1	BIT0

Mnemonic: CIDGA

Address: FAh

CIDGA.3: The CIDGD latch control signal. The rising high pulse latch CIDGD into CID gain control register.

CIDGA.2-0: The address to indicate CID input gain control registers.



6.3 Initial State of Registers

The following table lists the initial state of registers after different reset functions.

SFR ITEM	RESET INITIAL VALUE	POR	WDT RESET
SDRAL, SFRAH, CHPCON	00h	00h	00h
SFRFD, TA	ffh	ffh	ffh
SFRCN	3Fh	3Fh	3Fh
ACC, B, STATUS, PSW	00h	00h	00h
SP	07h	07h	07h
RPAGE	00h	00h	00h
P0, P1, P2, P3, P4, P0IO, P1IO, P2IO, P3IO, P4IO P5, P6, P7, P5IO, P6IO, P7IO	ffh	ffh	ffh
DPL, DPH, DPL1, DPH1, DPS	00h	00h	00h
PCON, TCON, TMOD	00h	00h	00h
TL0, TL1, TH0, TH1	00h	00h	00h
CKCON1, CKCON2, SCON, SCON1, SBUF1, REGVC	00h	00h	00h
SBUF	***** B	***** B	***** B
EIF, IE, HB, IP, EIE, EIP	00h	00h	00h
P1SR, P1EF, P1H, P2H, P3H, P4H, P5H, P6H, P7H	00h	00h	00h
CIDR, CIDFG, CIDPCR, CIDGD, CIDGA	00h	00h	00h
FSKDR, DTMFDR	***** B	***** B	***** B
DTMFPT, DTMFAT	19h	19h	19h
DTMFG, COMPR, IRC1, IRC2, FSKTC, FSKTB	00h	00h	00h
CASPT, CASAT	0fh	0fh	0fh
PMR	1000xx1B	1000xx1B	uuu00xx1B
BG	1ah	1ah	1ah
BGCON	06h	06h	06h
WDCON	0u000uu0B	01000000B	0u0001u0B

x: Un-used

u: unchanged

*: Depend on circuit detection

6.4 Instruction

The W925EP01 executes all the instructions of the standard 8032 family. However, timing of these instructions is different. In the W925EP01, each machine cycle consists of 4 clock periods, while in the standard 8032 it consists of 12 clock periods. Also, in the W925EP01 there is only one fetch per machine cycle i.e. 4 clocks per fetch, while in the standard 8032 there can be two fetches per machine cycle, which works out to 6 clocks per fetch.

Table 2 Instructions that affect Flag settings

INSTRUCTION	CARRY	OVERFLOW	AUXILIARY CARRY	INSTRUCTION	CARRY	OVERFLOW	AUXILIARY CARRY
INC, DEC	-	-	-	SETB C	1		
ADD	X	X	X	CLR C	0		
ADDC	X	X	X	CPL C	X		
SUBB	X	X	X	ANL C, bit	X		
MUL	0	X		ANL C, bit	X		
DIV	0	X		ORL C, bit	X		
DA A	X			ORL C, bit	X		
RRC A	X			MOV C, bit	X		
RLC A	X			CJNE	X		

A "X" indicates that the modification is as per the result of instruction.

A "-" indicates that the flag is not effected by the instruction.

Table 3 Instruction Timing for W925EP01

Instruction	HEX Op-Code	Bytes	Machine Cycles	Instruction	HEX Op-Code	Bytes	Machine Cycles
NOP	00	1	1	ANL A, R0	58	1	1
ADD A, R0	28	1	1	ANL A, R1	59	1	1
ADD A, R1	29	1	1	ANL A, R2	5A	1	1
ADD A, R2	2A	1	1	ANL A, R3	5B	1	1
ADD A, R3	2B	1	1	ANL A, R4	5C	1	1
ADD A, R4	2C	1	1	ANL A, R5	5D	1	1
ADD A, R5	2D	1	1	ANL A, R6	5E	1	1
ADD A, R6	2E	1	1	ANL A, R7	5F	1	1
ADD A, R7	2F	1	1	ANL A, @R0	56	1	1
ADD A, @R0	26	1	1	ANL A, @R1	57	1	1
ADD A, @R1	27	1	1	ANL A, direct	55	2	2
ADD A, direct	25	2	2	ANL A, #data	54	2	2
ADD A, #data	24	2	2	ANL direct, A	52	2	2
ADDC A, R0	38	1	1	ANL direct, #data	53	3	3
ADDC A, R1	39	1	1	ANL C, bit	82	2	2
ADDC A, R2	3A	1	1	ANL C, /bit	B0	2	2
ADDC A, R3	3B	1	1	CJNE A, direct, rel	B5	3	4
ADDC A, R4	3C	1	1	CJNE A, #data, rel	B4	3	4
ADDC A, R5	3D	1	1	CJNE @R0, #data, rel	B6	3	4
ADDC A, R6	3E	1	1	CJNE @R1, #data, rel	B7	3	4
ADDC A, R7	3F	1	1	CJNE R0, #data, rel	B8	3	4

W925EP01/ W925EP01FG



Table 4 Instruction Timing for W925EP01, continued

Instruction	HEX Op-Code	Bytes	Machine Cycles	Instruction	HEX Op-Code	Bytes	Machine Cycles
ADDC A, @R0	36	1	1	CJNE R1, #data, rel	B9	3	4
ADDC A, @R1	37	1	1	CJNE R2, #data, rel	BA	3	4
ADDC A, direct	35	2	2	CJNE R3, #data, rel	BB	3	4
ADDC A, #data	34	2	2	CJNE R4, #data, rel	BC	3	4
ACALL addr11	71,91,B1,11,31, 51,D1,F1	2	3	CJNE R5, #data, rel	BD	3	4
AJMP ADDR11	01,21,41,61,81, A1,C1,E1	2	3	CJNE R6, #data, rel	BE	3	4
CJNE R7, #data, rel	BF	3	4	JC rel	40	2	3
CLR A	E4	1	1	JNC rel	50	2	3
CPL A	F4	1	1	JB bit, rel	20	3	4
CLR C	C3	1	1	JNB bit, rel	30	3	4
CLR bit	C2	2	2	JBC bit, rel	10	3	4
CPL C	B3	1	1	LCALL addr16	12	3	4
CPL bit	B2	2	2	LJMP addr16	02	3	4
DEC A	14	1	1	MUL AB	A4	1	5
DEC R0	18	1	1	MOV A, R0	E8	1	1
DEC R1	19	1	1	MOV A, R1	E9	1	1
DEC R2	1A	1	1	MOV A, R2	EA	1	1
DEC R3	1B	1	1	MOV A, R3	EB	1	1
DEC R4	1C	1	1	MOV A, R4	EC	1	1
DEC R5	1D	1	1	MOV A, R5	ED	1	1
DEC R6	1E	1	1	MOV A, R6	EE	1	1
DEC R7	1F	1	1	MOV A, R7	EF	1	1
DEC @R0	16	1	1	MOV A, @R0	E6	1	1
DEC @R1	17	1	1	MOV A, @R1	E7	1	1
DEC direct	15	2	2	MOV A, direct	E5	2	2
DEC DPTR	A5	1	2	MOV A, #data	74	2	2
DIV AB	84	1	5	MOV R0, A	F8	1	1
DA A	D4	1	1	MOV R1, A	F9	1	1
DJNZ R0, rel	D8	2	3	MOV R2, A	FA	1	1
DJNZ R1, rel	D9	2	3	MOV R3, A	FB	1	1
DJNZ R5, rel	DD	2	3	MOV R4, A	FC	1	1
DJNZ R2, rel	DA	2	3	MOV R5, A	FD	1	1
DJNZ R3, rel	DB	2	3	MOV R6, A	FE	1	1
DJNZ R4, rel	DC	2	3	MOV R7, A	FF	1	1
DJNZ R6, rel	DE	2	3	MOV R0, direct	A8	2	2
DJNZ R7, rel	DF	2	3	MOV R1, direct	A9	2	2
DJNZ direct, rel	D5	3	4	MOV R2, direct	AA	2	2
INC A	04	1	1	MOV R3, direct	AB	2	2
INC R0	08	1	1	MOV R4, direct	AC	2	2
INC R1	09	1	1	MOV R5, direct	AD	2	2
INC R2	0A	1	1	MOV R6, direct	AE	2	2

W925EP01/ W925EP01FG



Table 5 Instruction Timing for W925EP01, continued

Instruction	HEX Op-Code	Bytes	Machine Cycles	Instruction	HEX Op-Code	Bytes	Machine Cycles
INC R3	0B	1	1	MOV R7, direct	AF	2	2
INC R4	0C	1	1	MOV R0, #data	78	2	2
INC R5	0D	1	1	MOV R1, #data	79	2	2
INC R6	0E	1	1	MOV R2, #data	7A	2	2
INC R7	0F	1	1	MOV R3, #data	7B	2	2
INC @R0	06	1	1	MOV R4, #data	7C	2	2
INC @R1	07	1	1	MOV R5, #data	7D	2	2
INC direct	05	2	2	MOV R6, #data	7E	2	2
INC DPTR	A3	1	2	MOV R7, #data	7F	2	2
JMP @A+DPTR	73	1	2	MOV @R0, A	F6	1	1
JZ rel	60	2	3	MOV @R1, A	F7	1	1
JNZ rel	70	2	3	MOV @R0, direct	A6	2	2
MOV @R1, direct	A7	2	2	RL A	23	1	1
MOV @R0, #data	76	2	2	RLC A	33	1	1
MOV @R1, #data	77	2	2	RR A	03	1	1
MOV direct, A	F5	2	2	RRC A	13	1	1
MOV direct, R0	88	2	2	SETB C	D3	1	1
MOV direct, R1	89	2	2	SETB bit	D2	2	2
MOV direct, R2	8A	2	2	SWAP A	C4	1	1
MOV direct, R3	8B	2	2	SJMP rel	80	2	3
MOV direct, R4	8C	2	2	SUBB A, R0	98	1	1
MOV direct, R5	8D	2	2	SUBB A, R1	99	1	1
MOV direct, R6	8E	2	2	SUBB A, R2	9A	1	1
MOV direct, R7	8F	2	2	SUBB A, R3	9B	1	1
MOV direct, @R0	86	2	2	SUBB A, R4	9C	1	1
MOV direct, @R1	87	2	2	SUBB A, R5	9D	1	1
MOV direct, direct	85	3	3	SUBB A, R6	9E	1	1
MOV direct, #data	75	3	3	SUBB A, R7	9F	1	1
MOV DPTR, #data 16	90	3	3	SUBB A, @R0	96	1	1
MOVC A, @A+DPTR	93	1	2	SUBB A, @R1	97	1	1
MOVC A, @A+PC	83	1	2	SUBB A, direct	95	2	2
MOVX A, @R0	E2	1	2	SUBB A, #data	94	2	2
MOVX A, @R1	E3	1	2	XCH A, R0	C8	1	1
MOVX A, @DPTR	E0	1	2	XCH A, R1	C9	1	1
MOVX @R0, A	F2	1	2	XCH A, R2	CA	1	1
MOVX @R1, A	F3	1	2	XCH A, R3	CB	1	1
MOVX @DPTR, A	F0	1	2	XCH A, R4	CC	1	1
MOV C, bit	A2	2	2	XCH A, R5	CD	1	1
MOV bit, C	92	2	2	XCH A, R6	CE	1	1
ORL A, R0	48	1	1	XCH A, R7	CF	1	1
ORL A, R1	49	1	1	XCH A, @R0	C6	1	1
ORL A, R2	4A	1	1	XCH A, @R1	C7	1	1
ORL A, R3	4B	1	1	XCHD A, @R0	D6	1	1
ORL A, R4	4C	1	1	XCHD A, @R1	D7	1	1



Table 6 Instruction Timing for W925EP01, continued

Instruction	HEX Op-Code	Bytes	Machine Cycles	Instruction	HEX Op-Code	Bytes	Machine Cycles
ORL A, R5	4D	1	1	XCH A, direct	C5	2	2
ORL A, R6	4E	1	1	XRL A, R0	68	1	1
ORL A, R7	4F	1	1	XRL A, R1	69	1	1
ORL A, @R0	46	1	1	XRL A, R2	6A	1	1
ORL A, @R1	47	1	1	XRL A, R3	6B	1	1
ORL A, direct	45	2	2	XRL A, R4	6C	1	1
ORL A, #data	44	2	2	XRL A, R5	6D	1	1
ORL direct, A	42	2	2	XRL A, R6	6E	1	1
ORL direct, #data	43	3	3	XRL A, R7	6F	1	1
ORL C, bit	72	2	2	XRL A, @R0	66	1	1
ORL C, /bit	A0	2	2	XRL A, @R1	67	1	1
PUSH direct	C0	2	2	XRL A, direct	65	2	2
POP direct	D0	2	2	XRL A, #data	64	2	2
RET	22	1	2	XRL direct, A	62	2	2
RETI	32	1	2	XRL direct, #data	63	3	3

6.5 Power Management

The W925EP01 has 3 operation mode, normal mode, idle mode and power down mode to manage the power consumption.

Normal Mode

Normal mode is used in the normal operation status. All functions can be worked in the normal mode.

Idle Mode

The user can put the device into idle mode by writing 1 to the bit PCON.0. The instruction that sets the idle bit is the last instruction that will be executed before the device goes into Idle Mode. In the Idle mode, the clock to the CPU is halted, but not to the Interrupt, Timer, Watchdog timer, Divider, Comparator and CID blocks. This forces the CPU state to be frozen; the Program counter, the Stack Pointer, the Program Status Word, the Accumulator and the other registers hold their contents. The port pins hold the logical states they had at the time Idle was activated. The Idle mode can be terminated in two ways. Since the interrupt controller is still active, the activation of any enabled interrupt can wake up the processor. This will automatically terminate the idle mode and clear the idle bit. And if bit IDLT (PCON.4) is cleared the Interrupt Service Routine (ISR) will be executed, else the idle mode is released directly without any execution of ISR. After the ISR, execution of the program will continue from the instruction, which put the device into idle mode.

The Idle mode can also be exited by activating the reset. The device can be put into reset by either applying a low on the external RESET pin or a power on/fail reset condition or a Watchdog timer reset. The external reset pin has to be held low for at least two machine cycles i.e. 8 clock periods to be recognized as a valid reset. In the reset, condition the program counter is reset to 0000h and all the SFRs are set to the reset condition. Since the clock is still running in the period of external reset therefore the instruction is executed immediately. In the Idle mode, the Watchdog timer continues to run, and if enabled, a time-out will cause a watchdog timer interrupt, which will wake up the device. The software must reset the Watchdog timer in order to preempt the reset, which will occur after 512 clock periods of the time-out.



Power down Mode

The device can be put into Power Down mode by writing 1 to bit PCON.1. The instruction that does this will be the last instruction to be executed before the device goes into Power Down mode. In the Power Down mode, all the clocks are stopped and the device comes to a halt. All activity is completely stopped and the power consumption is reduced to the lowest possible value. The port pins output the values held by their respective SFRs.

The W925EP01 will exit the Power Down mode by reset or external interrupts or ring detected. An external reset can be used to exit the Power down state. The low on RESET pin terminates the Power Down mode, and restarts the clock. The on-chip hardware will now provide a delay of 65536 clocks, which is used to provide time for the oscillator to restart and stabilize. Once this delay is complete, an internal reset is activated and the program execution will restart from 0000h. In the Power down mode, the clock is stopped, so the Watchdog timer cannot be used to provide the reset to exit Power down mode.

The W925EP01 can be woken from the Power Down mode by forcing an external interrupt pin activated and ring detected, provided the corresponding interrupt is enabled, while the global enable (EA) bit is set. While the power down is released, the device will experience a warm-up delay of 65536 clock cycles to ensure the stabilization of oscillation. Then device executes the interrupt service routine for the corresponding external interrupt or CID interrupt. After the interrupt service routine is completed, the program returns to the instruction after the one, which put the device into Power Down mode and continues from there. When RGSL (PMR.5) bit is set to 1, the CPU will use the internal RC oscillator instead of crystal to exit Power Down mode. The micro-controller will automatically switch from RC oscillator to crystal after a warm-up delay of 65536 crystal clocks. The RC oscillator runs at approximately 2–4 MHz. Using RC oscillator to exit from Power Down mode saves the time for waiting crystal start-up. It is useful in the low power system which usually be awakened from a short operation then returns to Power Down mode.

6.6 Reset

The user has several hardware related options for placing the W925EP01 into reset condition. In general, most register bits go to their reset value irrespective of the reset condition, but there are few flags that initial states are dependant on the source of reset. User can recognize the cause of reset by reading the flags. There are three ways of putting the device into reset state. They are External reset, Power on reset and Watchdog reset.

External Reset

The device continuously samples the RESET pin at state C4 of every machine cycle. Therefore, the RESET pin must be held for at least 2 machine cycles to ensure detection of a valid RESET high. The reset circuitry then synchronously applies the internal reset signal. Thus, the reset is a synchronous operation and requires the clock to be running to cause an external reset.

Once the device is in reset condition, it will remain so as long as RESET is 1. Even after RESET is deactivated, the device will continue to be in reset state for up to two machine cycles, and then begin program execution from 0000h. There is no flag associated with the external reset condition. However, since some flags indicate the cause of other two reset, the external reset can be considered as the default reset if those two flags are cleared.

Watchdog Timer Reset

The Watchdog timer is a free running timer with programmable time-out intervals. The user can reset the watchdog timer at any time to avoid producing the flag WDIF. If the Watchdog reset is enabled and the flag WDIF is set high, the watchdog timer reset is performed after the additional 512 clocks come. This places the device into the reset condition. The reset condition is maintained by hardware for two machine cycles. Once the reset is removed, the device will begin execution from 0000h.



6.7 Interrupt

The W925EP01 has a two priority levels interrupt structure with 12 interrupt sources. Each of the interrupt sources has an individual priority bit, flag, interrupt vector and enable bit. In addition, the interrupts can be globally enabled or disabled.

Interrupt Sources

The External Interrupts $\overline{INT0}$ and $\overline{INT1}$ can be either edge triggered or level triggered, depending on bits IT0 and IT1. The bits IE0 and IE1 in the TCON register are the flags, which are checked to generate the interrupt. In the edge triggered mode of the $\overline{INT0}$ and the $\overline{INT1}$ inputs are sampled in every machine cycle. If the sample is high in one cycle and low in the next, then a high to low transition is detected and the interrupts request flag IEx in TCON is set. The flag bit requests the interrupt. Since the external interrupts are sampled every machine cycle, they have to be held high or low for at least one complete machine cycle. The IEx flag is automatically cleared when the service routine is called. If the level triggered mode is selected, then the requesting source has to hold the pin low until the interrupt is serviced. The IEx flag will not be cleared by the hardware on entering the service routine. If the interrupt continues to be held low even after the service routine is completed, then the processor may acknowledge another interrupt request from the same source. Note that the external interrupts INT2 to INT3 are edge triggered only.

The TF0, TF1 flags generate the Timer 0, 1 Interrupts. These flags are set by the overflow in the Timer 0, Timer 1. The TF0 and TF1 flags are automatically cleared by the hardware when the timer interrupt is serviced.

The Watchdog timer can be used as a system monitor or a simple timer. In either case, when the time-out count is reached, the Watchdog timer interrupt flag WDIF (WDCON.3) is set. If the enable bit EIE.5 enables the interrupt, then an interrupt will occur.

The Serial block can generate interrupts on reception or transmission. There are two interrupt sources from the Serial block, which are obtained by the RI and TI bits in the SCON SFR and SF1 in the SCON1 SFR. RI and TI are not automatically cleared by the hardware, and the user will have to clear these bits using software, SF1 is cleared automatically when the serial port1 interrupt is serviced.

The divider interrupt is generated by DIVF that is set when divider overflows. DIVF is set by hardware and cleared when divider interrupt is serviced. The divider interrupt is enable/disable if the bit EDIV is high/low.

The comparator interrupt is produced by COMPF, which is set when the RESC bit is changed from low to high. RESC, which is the real-time result of comparator, set when the voltage of reference input is higher than the voltage of analog input.

The CID interrupt is generated by CIDF. The CIDF is a logic OR output of all CID flags which are set by hardware and cleared by software. The structure of the CID flags is shown in Figure 6-4.

Each of the individual interrupts can be enabled or disabled by setting or clearing the corresponding bits in the IE and EIE SFR. A bit EA, which is located in IE.7, is a global control bit to enable/disable the all interrupt. When bit EA is zero all interrupts are disabling and when bit EA is high, each interrupt is enabled individually by the corresponding bit.

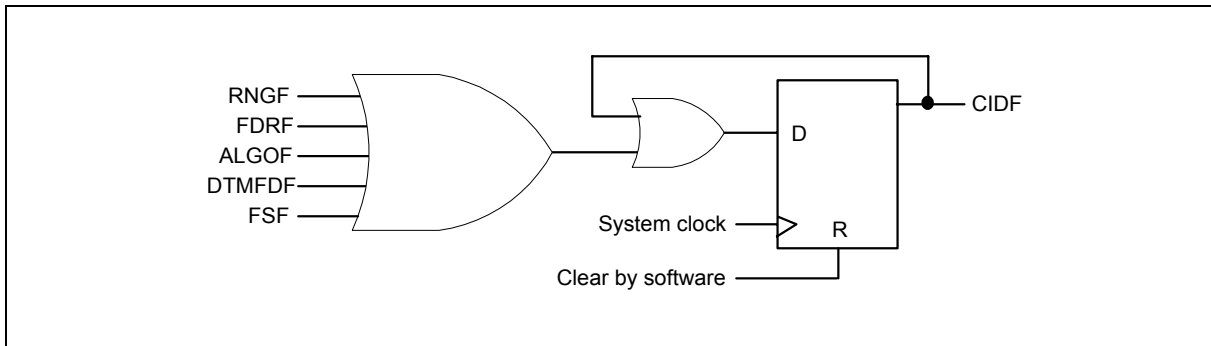

Figure 6-4 The Structure of CID Flags

Priority Level Structure

There are two priority levels for the interrupts, high and low. The interrupt sources can be individually set to either high or low levels. Naturally, a higher priority interrupt cannot be interrupted by a lower priority interrupt. However there exists a pre-defined hierarchy amongst the interrupts themselves. This hierarchy comes into play when the interrupt controller has to resolve simultaneous requests having the same priority level. This hierarchy is defined as shown below; the interrupts are numbered starting from the highest priority to the lowest.



Table 7 Interrupt table.

INTERRUPT	FLAG NAME	FLAG LOCATION	EN BIT	EN BIT LOCATION	PRIORITY	FLAG CLEARED BY	INTERRUPT VECTOR
External interrupt 0	IE0	TCON.1	EX0	IE.0	1 (highest)	hardware + software	03h
Timer0 overflow	TF0	TCON.5	ET0	IE.1	2	hardware + software	0Bh
External interrupt 1	IE1	TCON.3	EX1	IE.2	3	hardware + software	13h
Timer1 overflow	TF1	TCON.7	ET1	IE.3	4	hardware + software	1Bh
Serial port0	RI TI	SCON.0 SCON.1	ES0	IE.4	5	hardware + software	23h
Serial port1	SF1	SCON.7	ES1	IE.6	6	hardware + software	3Bh
External interrupt 2	<i>IE2</i>	EXIF.0	EX2	EIE.0	7	hardware + software	43h
External interrupt 3	<i>IE3</i>	EXIF.1	EX3	EIE.1	8	hardware + software	4Bh
CID	<i>CIDF</i>	EXIF.2	ECID	EIE.2	9	software	53h
Divider overflow	<i>DIVF</i>	EXIF.3	EDIV	EIE.3	10	hardware + software	5Bh
Compare difference	<i>COMPF</i>	EXIF.4	ECOMP	EIE.4	11	hardware + software	63h
Watchdog timer	<i>WDIF</i>	WDCON.3	EWDI	EIE.5	12 (lowest)	software	6Bh

Ps: The flags marked as the italic font are not bit-addressable.

The interrupt flags are sampled every machine cycle. In the same machine cycle, the sampled interrupts are polled and their priority is resolved. If certain conditions are met then the hardware will execute an internally generated LCALL instruction which will vector the process to the appropriate interrupt vector address. The conditions for generating the LCALL are

1. An interrupt of equal or higher priority is not currently being serviced.
2. The current polling cycle is the last machine cycle of the instruction currently being executed.
3. The current instruction does not involve a write to IP, IE, EIP or EIE registers and is not a RETI.

If any of these conditions is not met, then the LCALL will not be generated. The polling cycle is repeated every machine cycle, with the interrupts being sampled in the same machine cycle. If an interrupt flag is active in one cycle but not responded to, and is not active when the above conditions are met, the denied interrupt will not be serviced. This means that active interrupts are not remembered. Note that every polling cycle is new.

Execution continues from the vectored address until an RETI instruction is executed. On execution of the RETI instruction, the processor pops out the top content of Stack to the PC. The processor is not notified anything if the content of stack was changed. Note that a RET instruction would perform exactly the same process as a RETI instruction, but it would not inform the Interrupt Controller that the interrupt service routine is completed, and would leave the controller still thinking that the service routine is underway.

6.8 Programmable Timers/Counters

The W925EP01 has two 16-bit timer/counters. There are two 8-bit registers to perform a 16-bit counting register in every timer/counter. In timer/counter 0, TH0 is the upper 8 bits register and TL0 is the lower 8 bits register. Similarly, timer/counter 1 has two 8-bit registers, TH1 and TL1. Each timer/counter has 4 kinds of clock sources, which are $F_{osc}/4$, $F_{osc}/64$, $F_{osc}/1024$ and F_s . There are 3 operating modes in each timer/counter 0 and 1. The operating modes of timer/counter0 are identical to timer/counter1. The overflow signal of each timer/counter is sampled at phase 2 in every system machine cycle, therefore when the system clock and the timer/counter clock both are from sub-oscillator, if the overflow frequency is higher than $F_s/4$ the overflow flag cannot be sampled correctly. Only one overflow flag can be sampled in a machine cycle others will be missed.

MODE 0

In Mode 0, the timer/counters act as 13-bit timer/counters. The 13 bits consist of 8 bits of THx and lower 5 bits of TLx. The upper 3 bits of TLx are ignored.

The negative edge of the clock causes the content of the TLx register to increase one. When the fifth bit in TLx moves from 1 to 0, then the count in the THx register is incremented. When the count in THx moves from FFh to 00h, then the overflow flag TFX is set. The counted input is enabled only if TRx is set and either $GATE=0$ or $\overline{INTx}=1$. When C/\overline{T} is set to 0, then it will count clock cycles, and if C/\overline{T} is set to 1, then it will count 1 to 0 transitions on T0 (P3.4) for timer 0 and T1 (P3.5) for timer 1. When the 13-bit count reaches 1FFFh, the next count will cause it to rollover to 0000h. The timer overflow flag TFX of the relevant timer is set and if enabled an interrupts will occur. Note that when they are used as a timer, the bits of the CKCON1 select the time-base.

MODE1

Mode 1 is similar to Mode 0 except that the counting register forms a 16-bit counter, rather than a 13 bit counter.

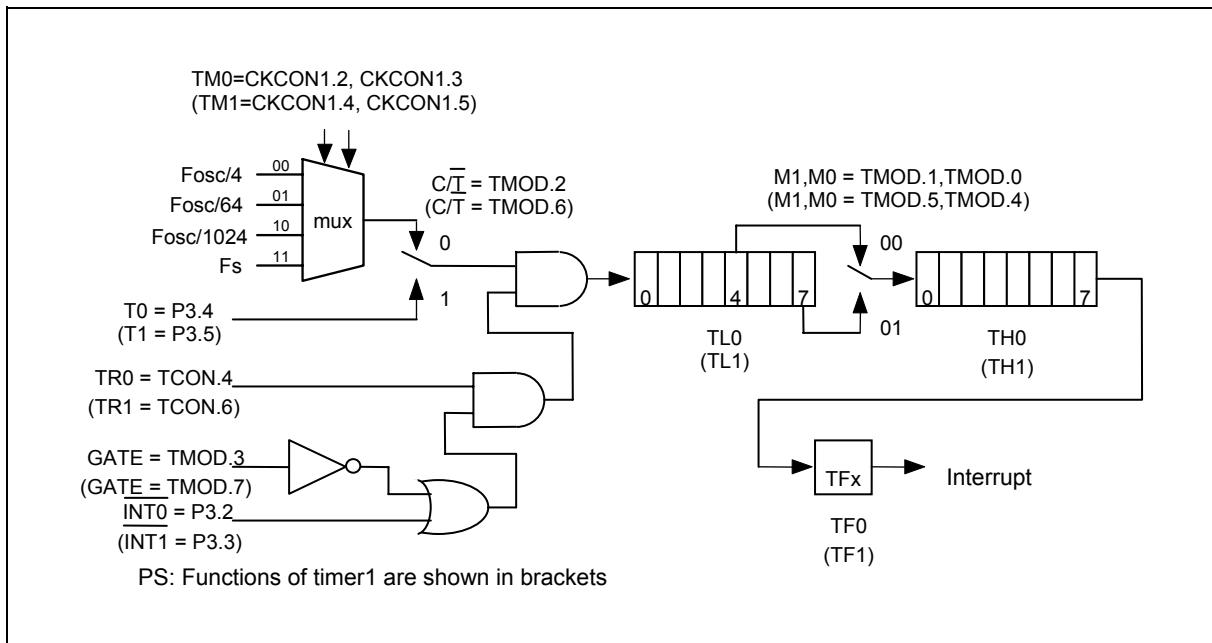

Figure 6-5 Mode 0 & Mode 1 of Timer/Counter 0 & 1



MODE 2

Mode 2 is the Auto Reload Mode. In mode 2, TLx acts as an 8-bit count register, while THx holds the reload value. When the TLx register overflows from FFh to 00h, the TFx bit is set and TLx is reloaded with the content of THx, and the counting process continues from the reloaded TLx. The reload operation leaves the content of the THx register unchanged. The TRx bit and the proper setting of GATE and $\overline{\text{INTx}}$ pins control counting.

BUZZER

In mode 2, timer 0 can be used to output an arbitrary frequency to the BUZ pin by programming bit6 and bit7 of CKCON2. BUZ pin can be configured as key tone (KT) output by setting BUZSL to high. When disabled buzzer output by clearing ENBUZ to low, the BUZ output is in floating status.

In the case where timer 0 clock input is FT, the desired frequency for BUZ output = $FT / (255 - \text{preset value} + 1) / 2$ (HZ).

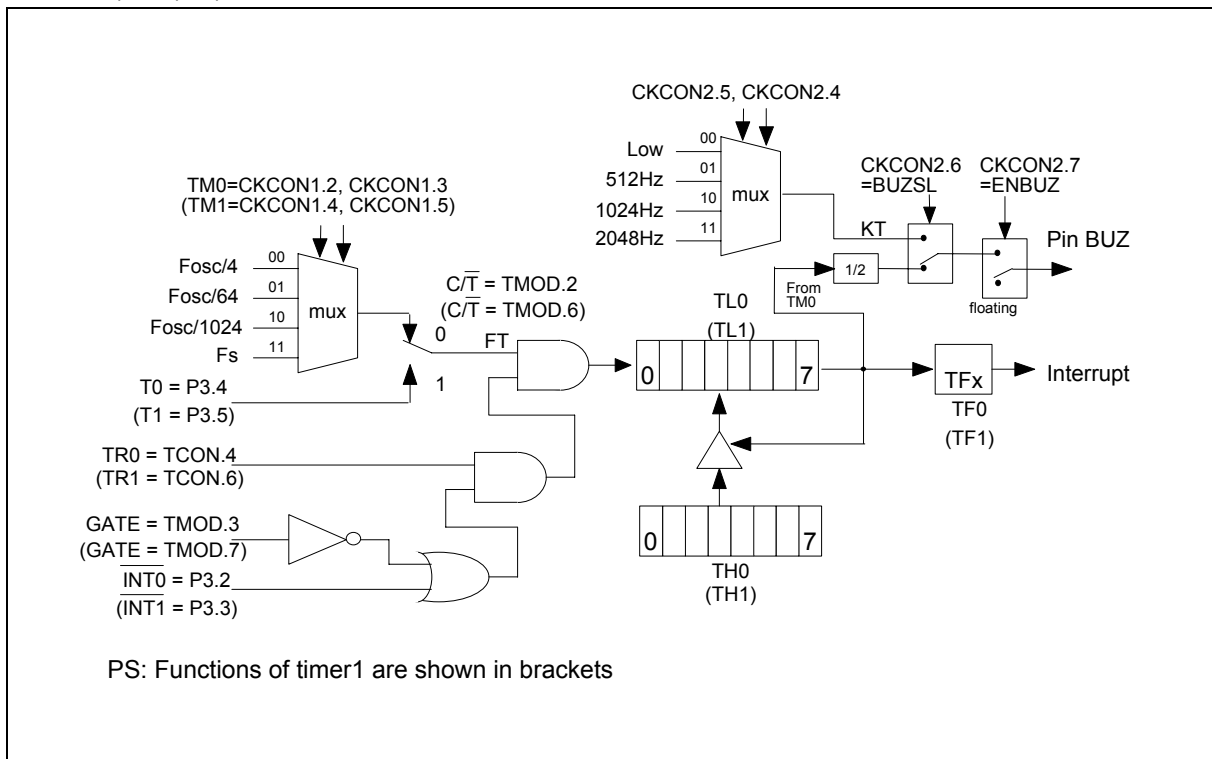

Figure 6-6 Mode 2 of Timer/Counter 0 & 1

When FT equals 32768 Hz, depending on the preset value of TM0, the BUZ pin will output a single tone signal in the tone frequency range from 64 Hz to 16384 Hz. The relation between the tone frequency and the preset value of TM0 is shown in the table below.

Table 8 The relation between the tone frequency and the preset value of TM0

		3rd octave			4th octave			5th octave		
		Tone frequency	TM0 preset value & BUZ frequency		Tone frequency	TM0 preset value & BUZ frequency		Tone frequency	TM0 preset value & BUZ frequency	
T O N E	C	130.81	83H	131.07	261.63	C1H	260.06	523.25	E1H	528.51
	C #	138.59	8AH	138.84	277.18	C5H	277.69	554.37	E3H	564.96
	D	146.83	90H	146.28	293.66	C8H	292.57	587.33	E4H	585.14
	D #	155.56	97H	156.03	311.13	CBH	309.13	622.25	E6H	630.15
	E	164.81	9DH	165.49	329.63	CEH	327.68	659.26	E7H	655.36
	F	174.61	A2H	174.30	349.23	D1H	348.58	698.46	E9H	712.34
	F #	185.00	A7H	184.09	369.99	D4H	372.35	739.99	EAH	744.72
	G	196.00	ACH	195.04	392.00	D6H	390.08	783.99	EBH	780.19
	G #	207.65	B1H	207.39	415.30	D9H	420.10	830.61	ECH	819.20
	A	220.00	B6H	221.40	440.00	DBH	442.81	880.00	EDH	862.84
	A #	233.08	BAH	234.05	466.16	DDH	468.11	932.23	EEH	910.22
	B	246.94	BEH	248.24	493.88	DF	496.48	987.77	EFH	963.76

Note: Central tone is DB (440 Hz).

WATCHDOG TIMER

The Watchdog timer is a free-running timer that can be programmed by the user to serve as a system monitor, a time-base generator or an event timer. It is a set of dividers that divides the system clock. The divider output is selectable and determines the time-out interval. In the condition of the timer-out expiring, the WDT interrupt and WDT reset may be executed if the corresponding enables control bits are set. The interrupt will occur if the individual interrupt enable and the global enable are set. The interrupt and reset functions are independent of each other and may be used separately or together depending on the users software.

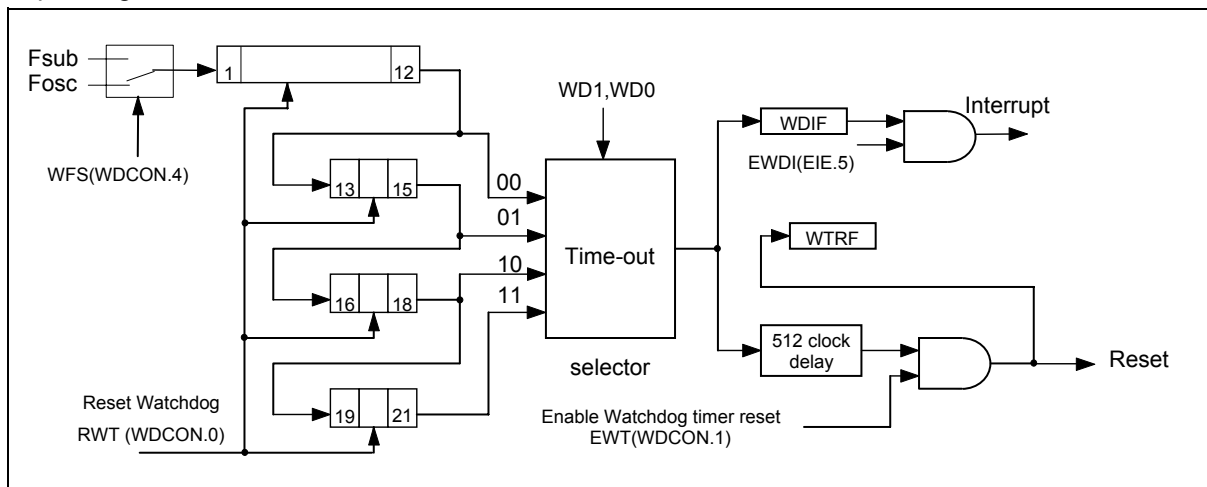

Figure 6-7 Watchdog Timer



The Watchdog timer should first be restarted by using RWT. This ensures that the timer starts from a known state. The RWT bit is used to restart the watchdog timer. This bit is self-clearing, i.e. after writing a 1 to this bit the software will automatically clear it. The watchdog timer will now count clock cycles. The time-out interval is selected by the two bits WD1 and WD0 (CKCON.7 and CKCON.6). When the selected time-out occurs, the Watchdog interrupt flag WDIF (WDCON.3) is set. After the time-out has occurred, the watchdog timer waits for an additional 512 clock cycles. The software must issue a RWT to reset the watchdog before the 512 clocks have elapsed. If the Watchdog Reset EWT (WDCON.1) is enabled, then 512 clocks after the time-out, if there is no RWT, a system reset due to Watchdog timer will occur. This will last for two machine cycles, and the Watchdog timer reset flag WTRF (WDCON.2) will be set. This indicates to the software that the watchdog was the cause of the reset.

When used as a simple timer, the reset and interrupt functions are disabled. The timer will set the WDIF flag each time the timer completes the selected time interval. The WDIF flag is polled to detect a time-out and the RWT allows software to restart the timer. The Watchdog timer can also be used as a very long timer. The interrupt feature is enabled in this case. Every time the time-out occurs an interrupt will occur if the global interrupt enable EA is set.

Table 9 Time-out values for the Watchdog timer

WD1	WD0	WATCHDOG INTERVAL	NUMBER OF CLOCKS	FOSC= 4 MHZ	FOSC= 32768 HZ	RESET OF CLOCKS (N CLOCK+512)
0	0	2^{12}	4096	1.024mS	0.125 S	4608
0	1	2^{15}	32786	8.192mS	1 S	33280
1	0	2^{18}	262144	65.536mS	8 S	262656
1	1	2^{21}	2097152	524.288mS	64 S	2097664

The Watchdog timer will be disabled by a power-on/fail reset. The Watchdog timer reset does not disable the watchdog timer, but will restart it. In general, software should restart the timer to put it into a known state.

The control bits that support the Watchdog timer are discussed below.

WATCHDOG CONTROL

WDIF: WDCON.3 - Watchdog Timer Interrupt flag. This bit is set whenever the time-out occurs in the watchdog timer. If the Watchdog interrupt is enabled (EIE.5), then an interrupt will occur (if the global interrupt enable is set and other interrupt requirements are met). Software or any reset can clear this bit.

WTRF: WDCON.2 - Watchdog Timer Reset flag. This bit is set whenever a watchdog reset occurs. This bit is useful for determined the cause of a reset. Software must read it, and clear it manually. A Power-fail reset will clear this bit. If EWT = 0, then this bit will not be affected by the watchdog timer.

EWT: WDCON.1 - Enable Watchdog timer Reset. This bit when set to 1 will enable the Watchdog timer reset function. Setting this bit to 0 will disable the Watchdog timer reset function, but will leave the timer running

RWT: WDCON.0 - Reset Watchdog Timer. This bit is used to clear the Watchdog timer and to restart it. This bit is self-clearing, so after the software writes 1 to it the hardware will automatically clear it. If the Watchdog timer reset is enabled, then the RWT has to be set by the user within 512 clocks of the time-out. If this is not done then a Watchdog timer reset will occur.



CLOCK CONTROL

WD1, WD0: CKCON.7, CKCON.6 - Watchdog Timer Mode select bits. These two bits select the time-out interval for the watchdog timer. The reset time is longer 512 clocks time than the interrupt time-out value.

The default Watchdog time-out is 2^{12} clocks, which is the shortest time-out period.

6.9 Serial Port

SERIAL PORT0

Serial port0 in the W925EP01 is a full duplex port. The W925EP01 provides the user with additional features such as the Frame Error Detection and the Automatic Address Recognition. The serial port0 are capable of synchronous as well as asynchronous communication. In Synchronous mode the W925EP01 generates the clock and operates in a half duplex mode. In the asynchronous mode, full duplex operation is available. This means that it can simultaneously transmit and receive data. The transmit register and the receive buffer are both addressed as SBUF Special Function Register. However any write to SBUF will be to the transmit register, while a read from SBUF will be from the receiver buffer register. The serial port0 can operate in four different modes as described below.

MODE 0

This mode provides synchronous communication with external devices. In this mode, serial data is transmitted and received on the RXD line. TXD is used to transmit the shift clock that is provided by the W925EP01 whether the device is transmitting or receiving. This mode is therefore a half duplex mode of serial communication. In this mode, 8 bits are transmitted or received per frame. The LSB is transmitted or received first. The baud rate is fixed at 1/12 or 1/4 of the oscillator frequency. This baud rate is determined by the SM2 bit (SCON.5). When bit SM2 is set to zero, the transceiver rate of serial rate is 1/12 of the clock. When bit SM2 is set to one, the transceiver rate of serial rate is 1/4 of the clock.

The functional block diagram is shown below. Data enters and leaves the Serial port on the RxD line. The TxD line is used to output the shift clock. The shift clock is used to shift data into and out of the W925EP01 and the device at the other end of the line. Any instruction that causes a write to SBUF will start the transmission. The shift clock will be activated and data will be shifted out on the RxD pin until all 8 bits are transmitted. If SM2 = 1, then the data on RxD will appear 1 clock period before the falling edge of shift clock on TxD. The clock on TxD then remains low for 2 clock periods, and then goes high again. If SM2 = 0, the data on RxD will appear 3 clock periods before the falling edge of shift clock on TxD. The clock on TxD then remains low for 6 clock periods, and then goes high again. This ensures that at the receiving end the data on RxD line can either be clocked on the rising edge of the shift clock on TxD or latched when the TxD clock is low.

After shifting in 8 data bits, there is one more shift to do, after which the SBUF and RB8 are loaded and RI is set. However, certain conditions must be met before the loading and setting of RI can be done.

1. RI must be 0 and
2. Either SM2 = 0, or the received stop bit = 1.

If these conditions are met, then the stop bit goes to RB8, the 8 data bits go into SBUF and RI is set. Otherwise, the received frame may be lost. After the middle of the stop bit, the receiver goes back to looking for a 1-to-0 transition on the Rx pin.

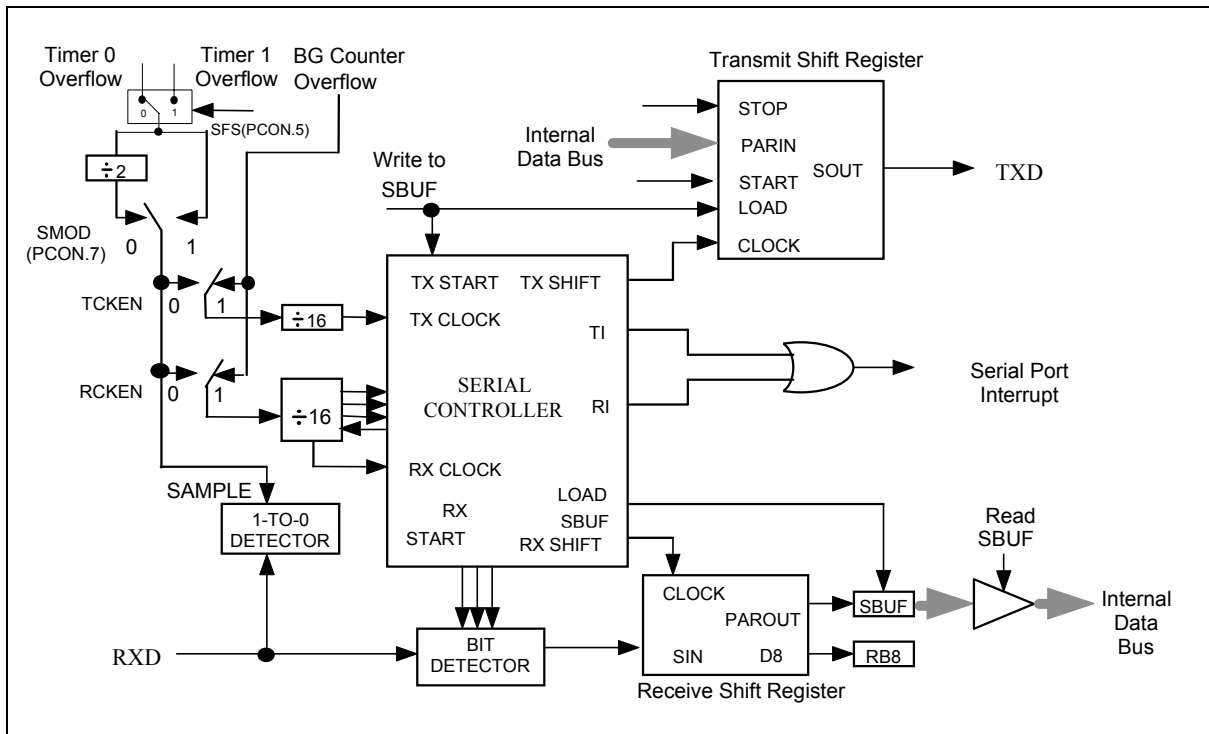

Figure 6-9 Serial Port 0 Mode 1

MODE 2

This mode uses 11 bits in asynchronous full-duplex communication. The functional description is shown in the figure below. The frame consists of one start bit (0), 8 data bits (LSB first), a programmable 9th bit (TB8) and a stop bit (0). The 9th bit received is put into RB8. The baud rate is programmable to 1/6 or 1/32 of the system clock which is determined by the SMOD (PCON.0). Transmission begins with a write to SBUF. The serial data is brought out on to TxD pin at C1 following the first rollover of the divide by 16 bit counter. The next bit is placed on TxD pin at C1 following the next rollover of the divide by 16 bit counter. Thus the transmission is synchronized to the divide by 16 bit counter, and not directly to the write to SBUF signal. After all 9 bits data has been transmitted, then the stop bit is transmitted. The TI flag is set in the C1 state after the stop bit has been put out on TxD pin. This will be at the 11th rollover of the divide by 16 bit counter after a write to SBUF. Reception is enabled only if REN is high. The serial port actually starts the receiving of serial data, with the detection of a falling edge on the Rx pin. The 1-to-0 detector continuously monitors the Rx pin, sampling it at the rate of 16 times the selected baud rate. When a falling edge is detected, the divide by 16 bit counter is immediately reset. This helps to align the bit boundaries with the rollovers of the divide by 16 bit counter. The 16 states of the counter effectively divide the bit time into 16 slices. The bit detection is done on a best of three bases. The bit detector samples the Rx pin, at the 8th, 9th

and 10th counter states. By using a majority 2 of 3 voting system, the bit value is selected. This is done to improve the noise rejection feature of the serial port. If the first bit detected after the falling edge of RxD pin, is not 0, then this indicates an invalid start bit, and the reception is immediately aborted. The serial port again looks for a falling edge in the RxD line. If a valid start bit is detected, then the rest of the bits are also detected and shifted into the SBUF. After shifting in 9 data bits, there is one more shift to do, after which the SBUF and RB8 are loaded and RI is set. However certain conditions must be met before the loading and setting of RI can be done.

1. RI must be 0 and
2. Either SM2 = 0, or the received stop bit = 1.

If these conditions are met, then the stop bit goes to RB8, the 8 data bits go into SBUF and RI is set. Otherwise, the received frame may be lost. After the middle of the stop bit, the receiver goes back to looking for a 1-to-0 transition on the RxD pin.

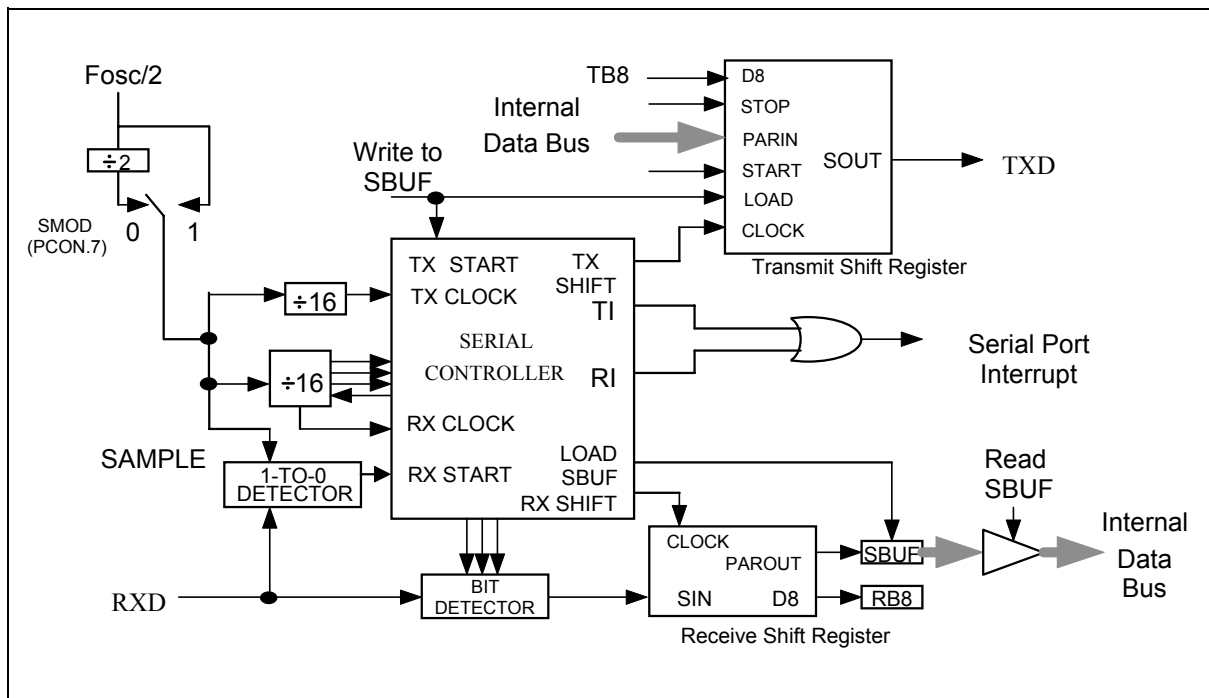

Figure 6-10 Serial Port 0 Mode 2

MODE 3

This mode is similar to Mode 2 in all respects, except that the baud rate is programmable. The user must first initialize the Serial related SFR SCON before any communication can take place. This involves selection of the Mode and baud rate. The Timer 0 or 1 or baud rate generator (BG) should also be initialized if modes 1 and 3 are used. In all four modes, transmission is started by any instruction that uses SBUF as a destination register. Reception is initiated in Mode 0 by the condition RI = 0 and REN = 1. This will generate a clock on the TxD pin and shift in 8 bits on the RxD pin. Reception is initiated in the other modes by the incoming start bit if REN = 1. The external device will start the communication by transmitting the start bit.

Table 10 Serial Ports Modes

SM1	SM0	MODE	TYPE	BAUD CLOCK	FRAME SIZE	START BIT	STOP BIT	9TH BIT FUNCTION
0	0	0	Synch.	4 or 12 TCLKS	8 bits	No	No	None
0	1	1	Asynch.	Timer 0 or 1	10 bits	1	1	None
1	0	2	Asynch.	16 or 32 TCLKS	11 bits	1	1	0, 1
1	1	3	Asynch.	Timer 0 or 1	11 bits	1	1	0, 1

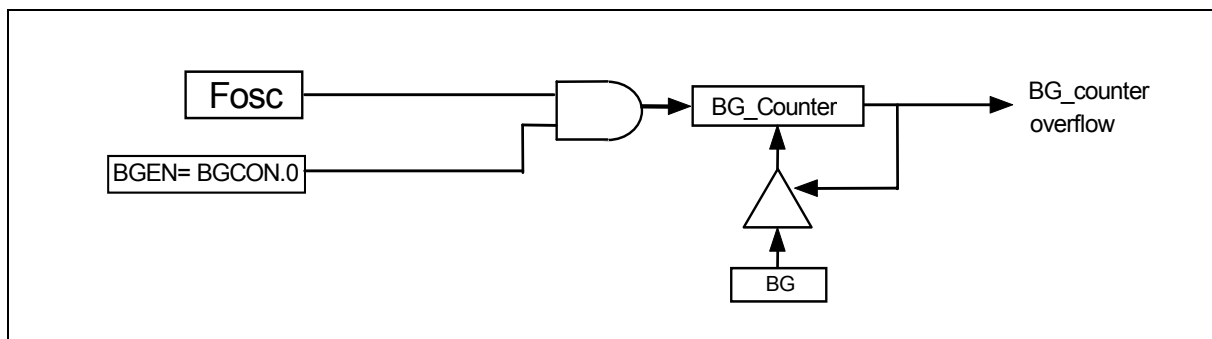

Figure 6-11 Serial Port0 Baud Rate Generator Mode

W925EP01/ W925EP01FG



- REN1: Set REN1 from 0 to 1 to start the serial port to receive 8-bit serial data.
- SFQ: SFQ=0 Serial clock output frequency is equal to $f_{osc} / 2$
SFQ=1 Serial clock output frequency is equal to $f_{osc} / 256$
- SEDG: SEDG=0 Serial data latched at falling edge of clock, SCLK=Low initially.
SEDG=1 Serial data latched at rising edge of clock, SCLK=High initially
- CLKIO: CLKIO=0 P4.0 (SCLK) work as output mode
CLKIO=1 P4.0 (SCLK) work as input mode
- SIO: SIO=0 P4.0 & P4.1 work as normal I/O pin
SIO=1 P4.0 & P4.1 work as Serial port1 function

Any instruction causes a write to SBUF1 will start the transmission of serial port1. As the REN1 is from 0 to 1, the serial port1 begins to receive a byte into SBUF1 in the frequency of the serial clock. REN1 could be cleared by software after receive function begins. The LSB is transmitted/ received first. The I/O mode of serial clock pin is controlled by CLKIO. User has to take care the initial state of the serial port pins.

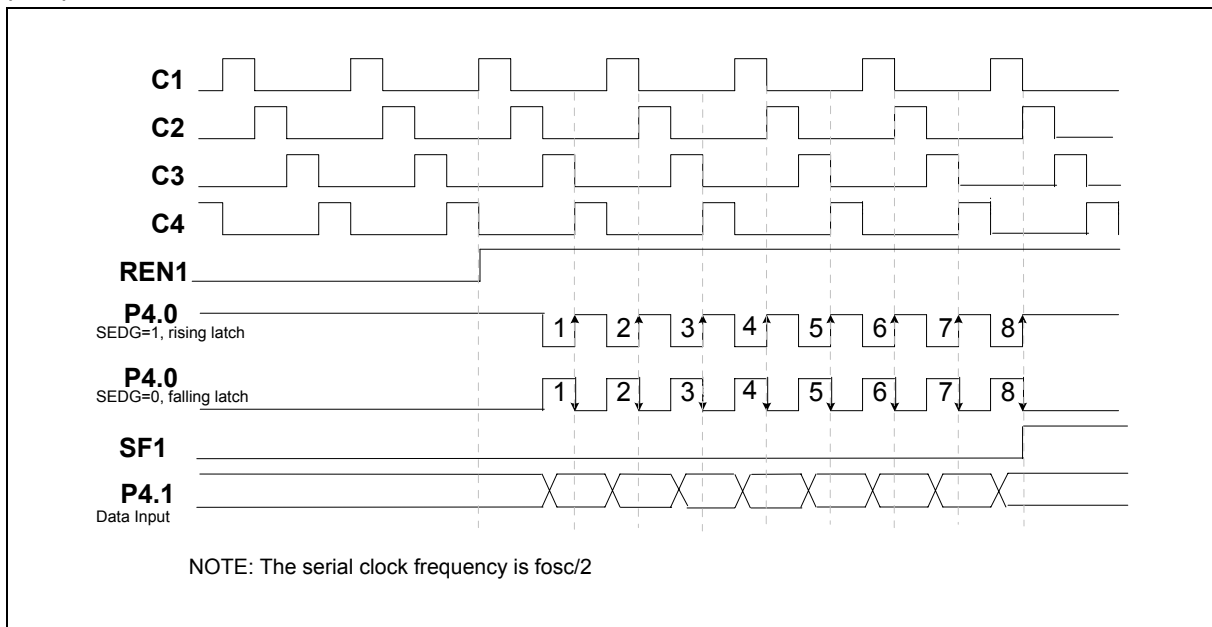

Figure 6-6 Timing of the Serial port1 Input Function

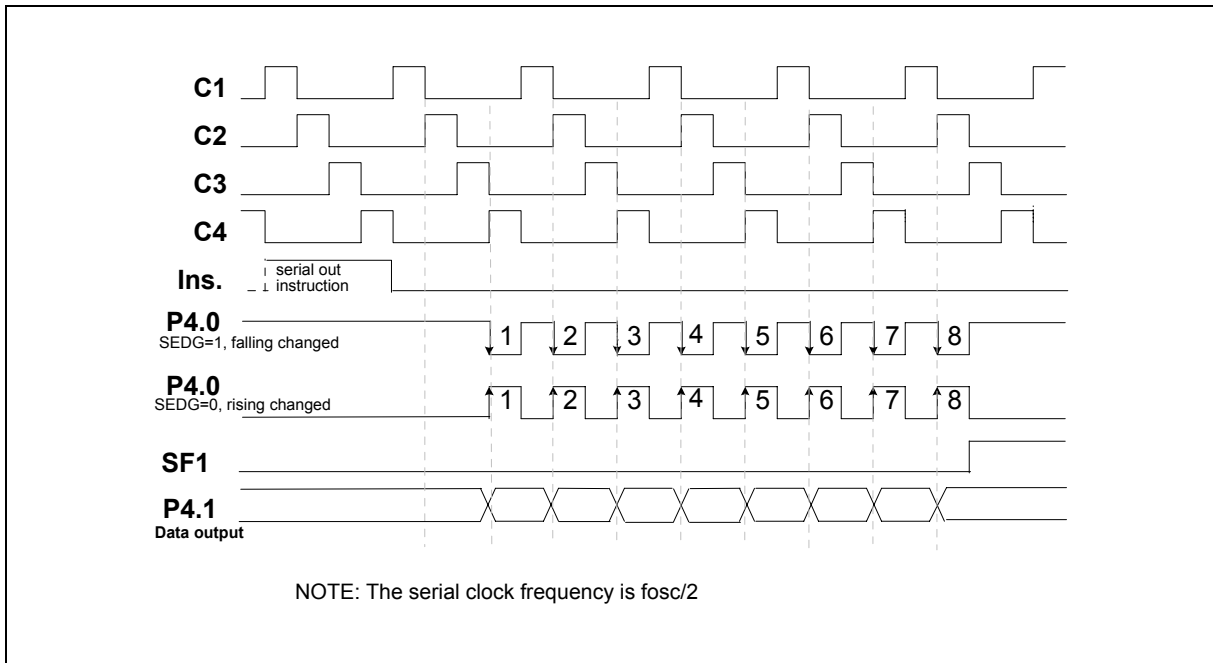

Figure 6-7 Timing of the Serial port1 Output Function

6.10 Comparator

A built-in comparator can compare the analog signal. There is an analog input path from pin VNEG. And one reference input from pin VPOS. When the voltage of positive input is higher than the negative input, the comparator output will be high. The RESEC (COMPR.3) is the result of the comparison. An internal rising signal on RESC produces interrupt flag of COMPF (EXIF.4). The flag COMPF is cleared when comparator interrupt routine is executed or cleared by software. Set COMPEN to enable the comparator function.

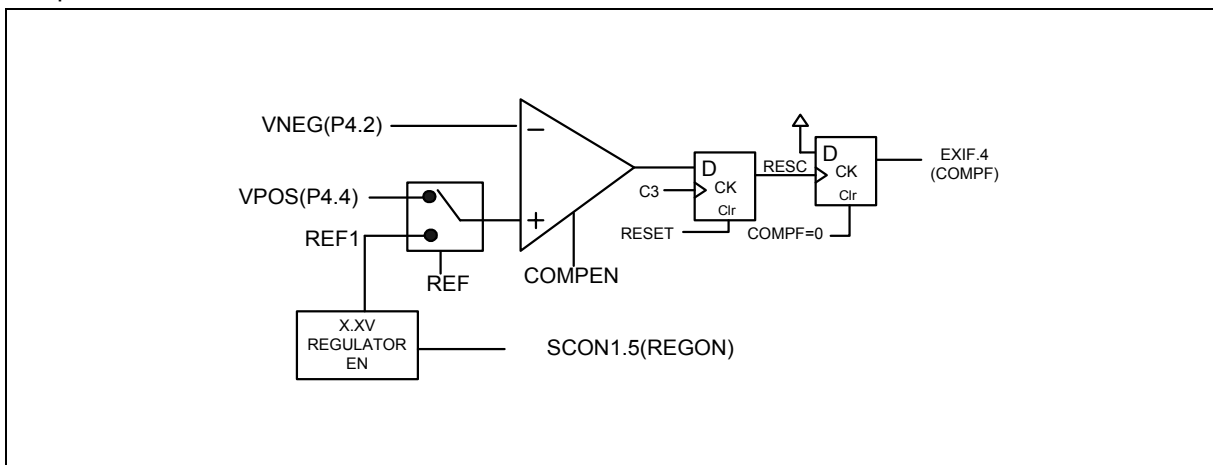

Figure 6-8 The Configuration of Comparator



6.11 DTMF Generator

W925EP01 provides a DTMF generator, which outputs the dual tone multi-frequency signal to the DTMF pin. The DTMF generator can work well at the operating frequency of 4M/8MHz. A DTMF generator register DTMFG controls the DTMF output and specifies the desired low/high frequency. The tones are divided into two groups (low group and high group). When the generator is disabled, the DTMF pin is in tri-state. The relation between the DTMF signal and the corresponding touch-tone keypad is shown in Figure 6-9.

	C1	C2	C3	C4	ROW/COL	FREQUENCY
R1	1	2	3	A	R1	697 Hz
R2	4	5	6	B	R2	770 Hz
R3	7	8	9	C	R3	852 Hz
R4	*	0	#	D	R4	941 Hz
					C1	1209 Hz
					C2	1336 Hz
					C3	1477 Hz
					C4	1633 Hz

Figure 6-9 The Relation Between DTMF and Keypad

Bit:	7	6	5	4	3	2	1	0
	CASGE	DTGE	HE	LE	L1	L0	H1	H0
Mnemonic: DTMFG								Address: BAh

CASGE: Enable CAS tone output to DTMF pin.

DTGE: Enable dual tone output to DTMF pin.

HE: Enable CAS/DTMF high group frequency output.

LE: Enable CAS/DTMF low group frequency output.

L1	L0	H1	H0	DTMF SELECTED TONE
x	x	0	0	1209Hz
x	x	0	1	1336Hz
x	x	1	0	1477Hz
x	x	1	1	1633Hz
0	0	x	x	697Hz
0	1	x	x	770Hz
1	0	x	x	852Hz
1	1	x	x	941Hz



6.12 FSK Generator

W925EP01 provides a FSK generator, which outputs the FSK signal to the DTMF pin. The FSK output share with DTMF output pin. It can out FSK signal with 1200Hz baud rate of ITU-T V.23 or Bellcore 202 signal. A FSK transmit data register (FSKTB) specifies the desired output data. The FSK Transmit Control Register (FSKTC) can control whether the FSK signal will be output or not. The relation timing is shown in Figure 6-10

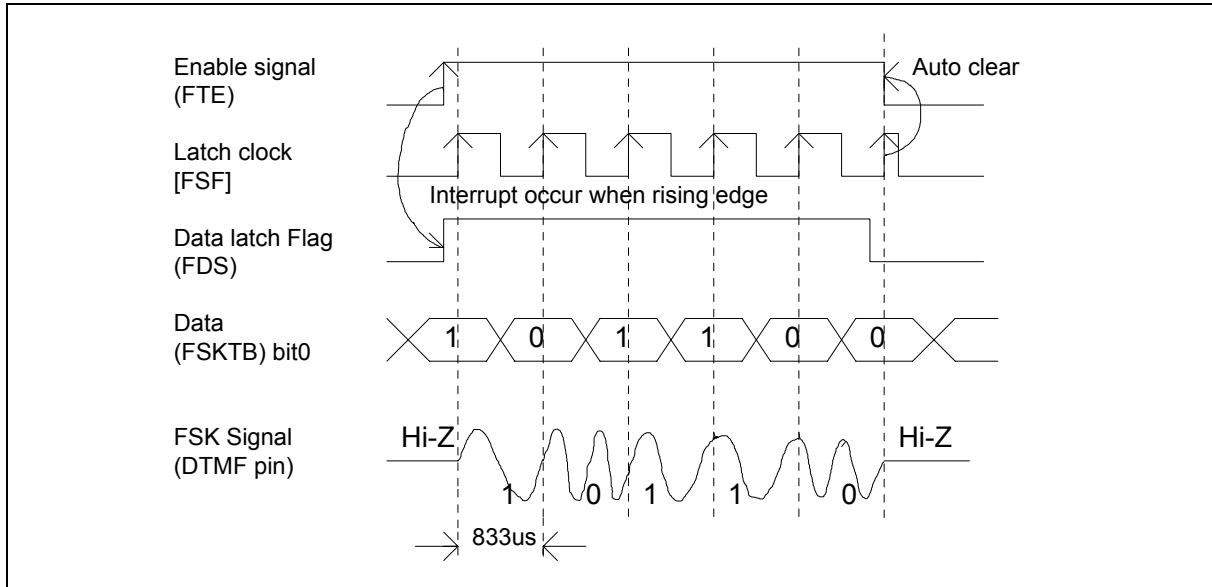

Figure 6-10 FSK Modulator

FSK TRANSMIT CONTROL REGISTER

(initial=00H)

Bit:	7	6	5	4	3	2	1	0
	FTE	FTM	FDS	-	-	-	LO1	LO0

Mnemonic: FSKTC

Address: C6h

FTE: FSK transmit Enable. Enable=1, Disable=0

FTM: FSK signal Standard. Bellcore 202=1, V.23=0

FDS: FSK data sending status

LO0, LO1: FSK transmitting level option

FSK output level	LO1	LO0
150mV	0	0
125mV	0	1
100mV	1	0
75mV	1	1

W925EP01/ W925EP01FG



FSK TRANSMIT DATA BUFFER

(initial=00H)

Bit:	7	6	5	4	3	2	1	0
	-	-	-	-	-	-	-	FSKTB.0

Mnemonic: FSKTB

Address: C7h

FSKTB.0: Only this bit will be latched and send out as FSK signal

When FTE enable will set the FDS to high to enable the internal latch clock in 1200Hz. When FDS is in high state, FSKTB bit0 will be sent out by FSK modulator at the rising edge of latch clock. FDS could be cleared by software to inform no more data will be sent out after the last bit is sent completely. If the FDS is cleared then FTE will become low at next rising latch clock to disable FSK modulator and clear FDS by hardware automatically.

When FTE is set, FSK modulation flag (FSF) will be set at every rising edge of latch clock to produce an interrupt shared with CID interrupt routine. If a CID interrupt occurs, user can check FSF to know if this interrupt is caused by FSK modulator. The only way to stop FSK signal immediately is to disable FTE by software.

6.13 CAS Generator

W925EP01 provides a CAS generator, which outputs the CAS signal to the DTMF pin. The CAS generator can work well at the operating frequency of 4M/8MHz. A CAS generator register CASGE controls the CAS output and specifies the desired low/high frequency. The tones are divided into two groups (low group and high group). When the CASGE is cleared, the DTMF pin is in tri-state. The relation between the CAS signal and the corresponding is shown in following.

Bit:	7	6	5	4	3	2	1	0
	CASGE	DTGE	HE	LE	L1	L0	H1	H0

Mnemonic: DTMFG

Address: BAh

CASGE: Enable CAS tone output to DTMF pin.

HE: Enable CAS/DTMF high group frequency output.

LE: Enable CAS/DTMF low group frequency output.

HE	LE	CAS SELECTED TONE
0	0	Low
0	1	2130Hz
1	0	2750Hz
1	1	2130Hz & 2750Hz

To change the signal strength of CAS, user can modify the SFR bit0 and bit1 in FSKTC.

LO0, LO1: CAS transmitting level option. It just is suitable for 2130Hz. The output levels of 2750Hz will higher 2dBm than it.



CAS/FSK OUTPUT LEVEL	LO1	LO0
150mV	0	0
125mV	0	1
100mV	1	0
75mV	1	1

6.14 I/O Ports

There are five 8-bits ports named from P0 to P4 in W925EP01. All ports can be configured as input or output mode. Except P0, every port has pull high resistor enable/disable by PxH register. After reset the initial state of each port is in input mode and the value of the registers from P0 to P3 are FFh. The I/O port is described as below:

P0: I/O mode is controlled by P0IO. Only **P0 output as open drain mode** and without pull high resistor.

P1: I/O mode is controlled by P1IO. Pull high is controlled by P1H. **P1.0~P1.3 work as INT2, P1.4~P1.7 work as INT3.** The **falling edge** on P1 pins will produce INT2 and INT3 flag. P1 is configured as INT2/INT3 by P1EF register.

P2: I/O mode is controlled by P2IO. Pull high is controlled by P2H.

P3: I/O mode is controlled by P3IO. Pull high is controlled by P3H.

P3.7	\overline{RD}	Read low pulse signal when reading external RAM
P3.6	\overline{WR}	Write low pulse signal when writing external RAM
P3.5	T1	Timer/counter 1 external count input
P3.4	T0	Timer/counter 0 external count input
P3.3	$\overline{INT1}$	External interrupt 1
P3.2	$\overline{INT0}$	External interrupt 0
P3.1	TxD	Serial port0 output
P3.0	RxD	Serial port0 input

P4: I/O mode is controlled by P4IO. Pull high is controlled by P4H.

Special function of P4 is described below.

P4.7-5	I/O	Normal I/O
P4.4	VPOS	Positive input of the comparator
P4.2	VNEG	Negative input of the comparator
P4.1	SDATA	Serial port1 output
P4.0	SCLK	Serial port1 input

6.15 Divider

A built-in 13/14-bit binary up counter designed to generate periodic interrupt. The clock source is from sub-oscillator. When the frequency of sub-crystal is 32768Hz, it provides the divider interrupt in the period of 0.25/0.5 second. Bit DIVS controls the degree of divider. When DIVA is set to high, it will enable the divided counter; when DIVA is low to reset divider and stop counting. As the divider overflows, the divider interrupt flag DIVF is set. DIVF is clear by software or serving divider interrupt routine.

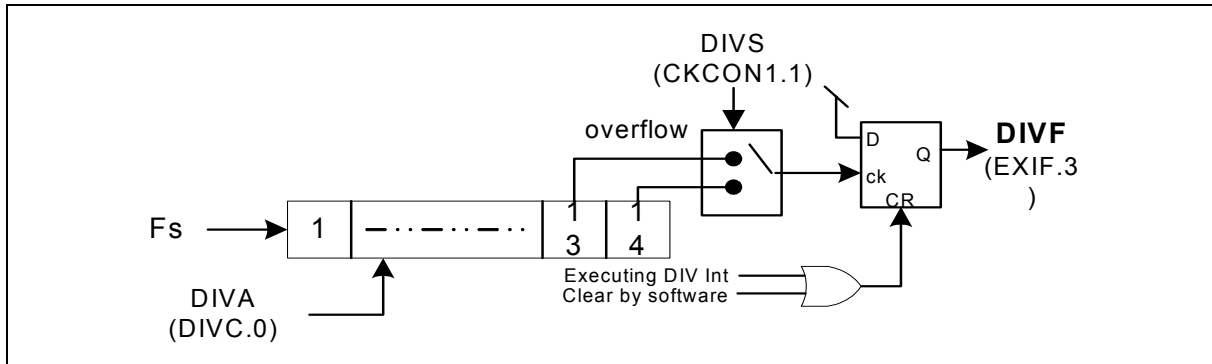

Figure 6-11 13/14-bit Divider

6.16 Timed Access Protection

The W925EP01 has a new feature, CHPCON for ISP function, which are crucial to proper operation of the system. If left unprotected, errant code may write to the CHPCON control bits resulting in incorrect operation and loss of control. In order to prevent this, the W925EP01 has a protection scheme that controls the write access to critical bits. This protection scheme is done using a timed access.

In this method, the bits that are to be protected have a timed write enable window. A write is successful only if this window is active, otherwise the write will be discarded. This write enable window is open for 3 machine cycles if certain conditions are met. After 3 machine cycles, this window automatically closes. The window is opened by writing AAh and immediately 55h to the Timed Access(TA) SFR. This SFR is located at address C7h. The suggested code for opening the timed access window is

```

TA      REG      EEh      ;define new register TA, located at 0EEh
      MOV      TA, #AAh
      MOV      TA, #55h
    
```

When the software writes AAh to the TA SFR, a counter is started. This counter waits for 3 machine cycles looking for a write of 55h to TA. If the second write (55h) occurs within 3 machine cycles of the first write (AAh), then the timed access window is opened. It remains open for 3 machine cycles, during which the user may write to the protected bits. Once the window closes the procedure must be repeated to access the other protected bits.



Examples of Timed Assessing are shown below.

Example 1: Valid access

```
MOV  TA, #0AAh    ;3 M/C
MOV  TA, #055h    ;3 M/C
MOV  CHPCON, #1   ;3 M/C
```

Note: M/C = Machine Cycles

Example 2: Invalid access

```
MOV  TA, #0AAh    ;3 M/C
MOV  TA, #055h    ;3 M/C
NOP                      ;1 M/C
MOV  CHPCON, #1   ;3 M/C
```

Example 3: Invalid access

```
MOV  TA, #0AAh    ;3 M/C
NOP                      ;1 M/C
MOV  TA, #055h    ;3 M/C
MOV  CHPCON, #1   ;3 M/C
```

In the first examples, the writing to the protected bits is done before the 3 machine cycle window closes. In Example 2, however, the writing to the protected bit occurs after the window has closed, and so there is effectively no change in the status of the protected bit. In Example 3, the second write to TA occurs 4 machine cycles after the first write, therefore the timed access window is not opened at all, and the write to the protected bit fails.



6.17 Hardware Writer Mode

1. H/W Writer Mode

This mode is for the writer to write / read Flash EPROM operation. A general user may not enter this mode.

2. Enter Flash Writer Timing

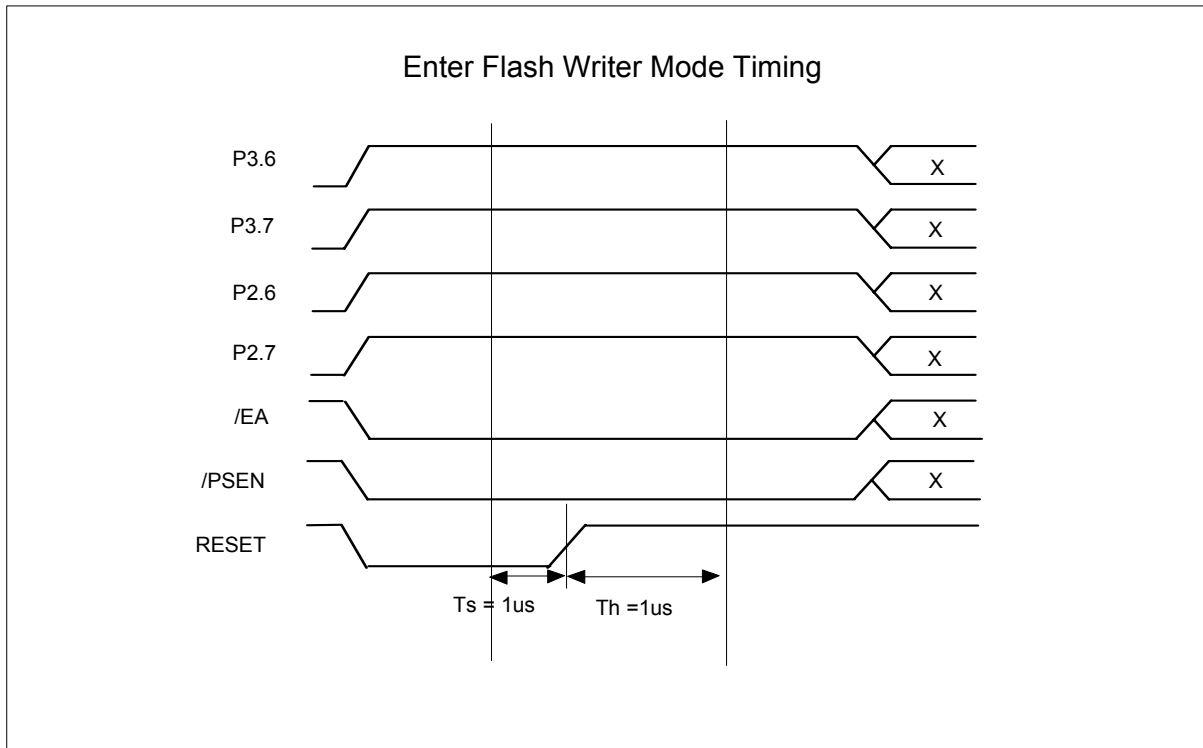

6.18 In-System Programming (ISP) Mode

The W925EP01 equips one 64K byte of main Flash EPROM bank for application program (called APROM) and one 4K byte of auxiliary Flash EPROM bank for loader program (called LDRM). In the normal operation, the micro-controller executes the code in the APROM. If the content of APROM needs to be modified, the W925EP01 allows user to activate the In-System Programming (ISP) mode by setting the CHPCON register. **The CHPCON is read-only by default, software must write two specific values AAH, and then 55H sequentially to the TA register to enable the CHPCON write attribute. Writing TA register with the values except AAH and 55H will close CHPCON register write attribute.** The W925EP01 achieves all in-system programming operations including enter/exit ISP Mode, program, erase, read ... etc, during device in the idle mode. Setting the bit CHPCON.0 the device will enter in-system programming mode after a wake-up from idle mode. Because device needs proper time to complete the ISP operations before awoken from idle mode, software may use timer interrupt to control the duration for device wake-up from idle mode. To perform ISP operation for revising contents of APROM, software located at APROM setting the CHPCON register then enter idle mode, after awoken from idle mode the device executes the corresponding interrupt service routine in LDRM. Because the device will clear the program counter while switching from APROM to LDRM, the first execution of RETI instruction in interrupt service routine will jump to 00H at LDRM area. The device offers a software-reset for switching back to APROM while the content of APROM has been

W925EP01/ W925EP01FG



updated completely. **Setting CHPCON register bit 0, 1 and 7 to logic-1 will result a software-reset to reset the CPU.** The software reset serves as an external reset. This in-system programming feature makes the job easy and efficient in which the application needs to update firmware frequently. In some applications, the in-system programming features make it possible to easily update the system firmware without opening the chassis.

NOTE: The ISP Mode operates by supply voltage from 3.3V to 5.5V.

SFRAH, SFRAL: The objective address of on-chip Flash EPROM in the in-system programming mode. SFRAH contains the high-order byte of address. SFRAL contains the low-order byte of address.

SFRFD: The programming data for on-chip Flash EPROM in programming mode.

SFRCN: The control byte of on-chip Flash EPROM programming mode.

SFRCN (E7H)

BIT	NAME	FUNCTION
7	-	Reserve.
6	WFWIN	On-chip Flash EPROM bank select for in-system programming. = 0: 64K bytes Flash EPROM bank is selected as destination for re-programming. = 1: 4K bytes Flash EPROM bank is selected as destination for re-programming.
5	OEN	Flash EPROM output enable.
4	CEN	Flash EPROM chip enable.
3, 2, 1, 0	CTRL[3:0]	The Flash control signals

MODE	WFWIN	OEN	CEN	CTRL<3:0>	SFRAH, SFRAL	SFRFD
Erase 64KB APROM	0	1	0	0010	X	X
Program 64KB APROM	0	1	0	0001	Address in	Data in
Read 64KB APROM	0	0	0	0000	Address in	Data out
Erase 4KB LDROM	1	1	0	0010	X	X
Program 4KB LDROM	1	1	0	0001	Address in	Data in
Read 4KB LDROM	1	0	0	0000	Address in	Data out



In-System Programming Control Register (CHPCON)

CHPCON (EFH)

BIT	NAME	FUNCTION
7	SWRHWB	Set this bit to launch a whole device reset that is same as asserting high to RESET pin, micro-controller will be back to initial state and clear this bit automatically. To read this bit, its alternate function to indicate the ISP hardware reboot mode is invoking when read it in high.
6	-	Reserve.
5	LDAP	This bit is Read Only. High: device is executing the program in LD Flash EPROM. Low: device is executing the program in AP Flash EPROM.
4	-	Reserve.
3	-	Reserve.
2	-	Reserve.
1	FBOOTSL	Loader program residence selection. Set to high to route the device fetching code from LDROM.
0	FPROGEN	In System Programming Mode Enable. Set this bit to launch the ISP mode. Device will operate ISP procedures, such as Erase, Program and Read operations, according to correlative SFRs settings. During ISP mode, device achieves ISP operations by the way of IDLE state. In the other words, device is not indeed in IDLE mode is set bit PCON.1 while ISP is enabled. Clear this bit to disable ISP mode, device get back to normal operation including IDLE state.

F04KBOOT Mode (Hardware Reboot from LDROM)

By default, the W925EP01 boots from APROM program after a power on reset. On some occasions, user can force the W925EP01 to boot from the LDROM program via following settings. The possible situation that you need to enter F04KBOOT mode when the APROM program can not run properly and device can not jump back to LDROM to execute in-system programming function. Then you can use this F04KBOOT mode to force the W925EP01 jumps to LDROM and executes in-system programming procedure. When you design your system, you may reserve the pins P4.7 to switches or jumpers. For example in a CD-ROM system, you can connect the P4.7 to PLAY or EJECT buttons on the panel. When the APROM program fails to execute the normal application program, user can press both two buttons (P4.7 & RESET) at the same time and then turn on the power of the personal computer to force the W925EP01 to enter the F04KBOOT mode. After power on of personal computer, you can release both buttons and finish the in-system programming procedure to update the APROM code. In application system design, user must take care of the P2, P3, \overline{EA} and \overline{PSEN} pin value at reset to prevent from accidentally activating the programming mode or F04KBOOT mode.



F04KBOOT MODE

OPTION1 BITS	RESET	P4.7	MODE
Bit 5 = 0	H↑	L	REBOOT

The Reset Timing For Entering LD REBOOT Mode(Option1 bit5 = L)

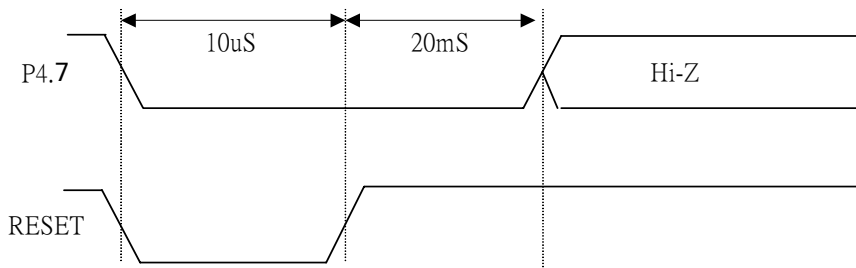

The Algorithm of In-System Programming

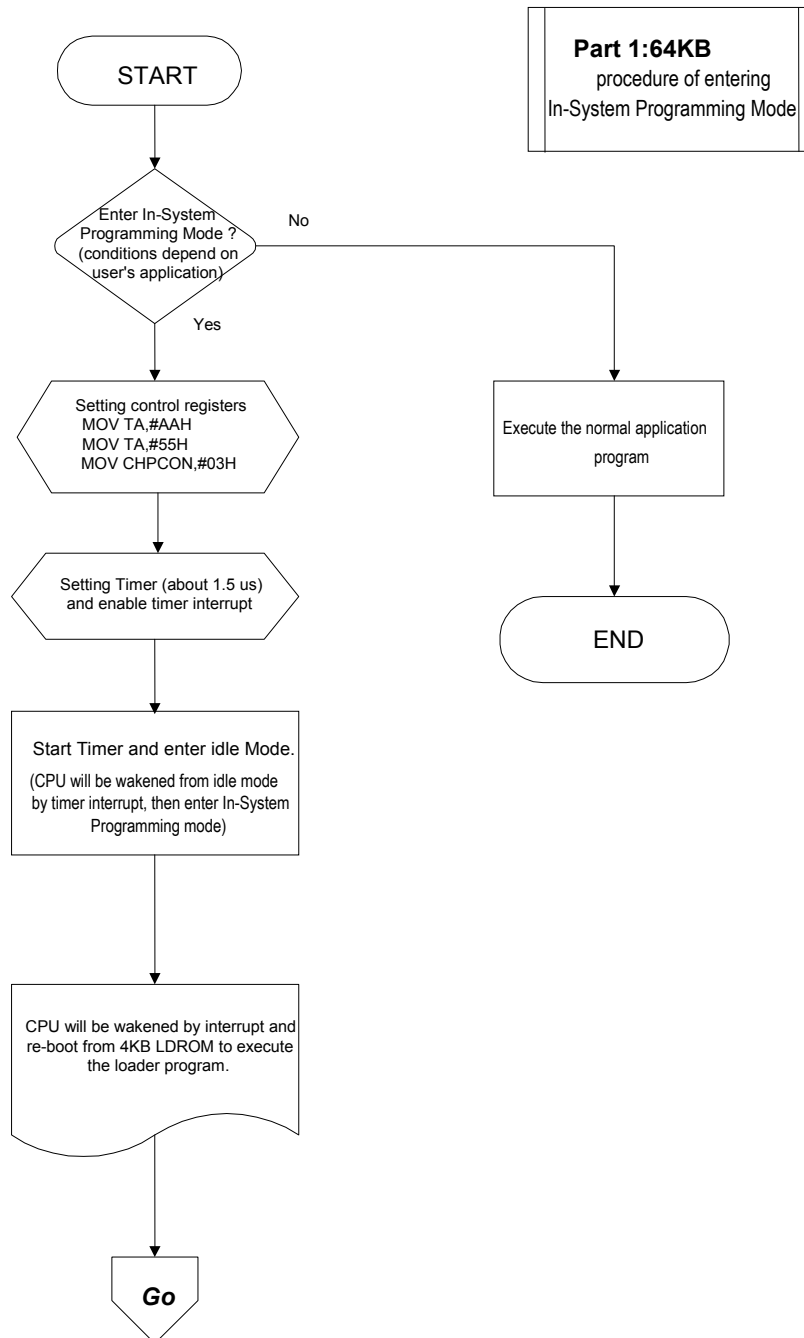

W925EP01/ W925EP01FG

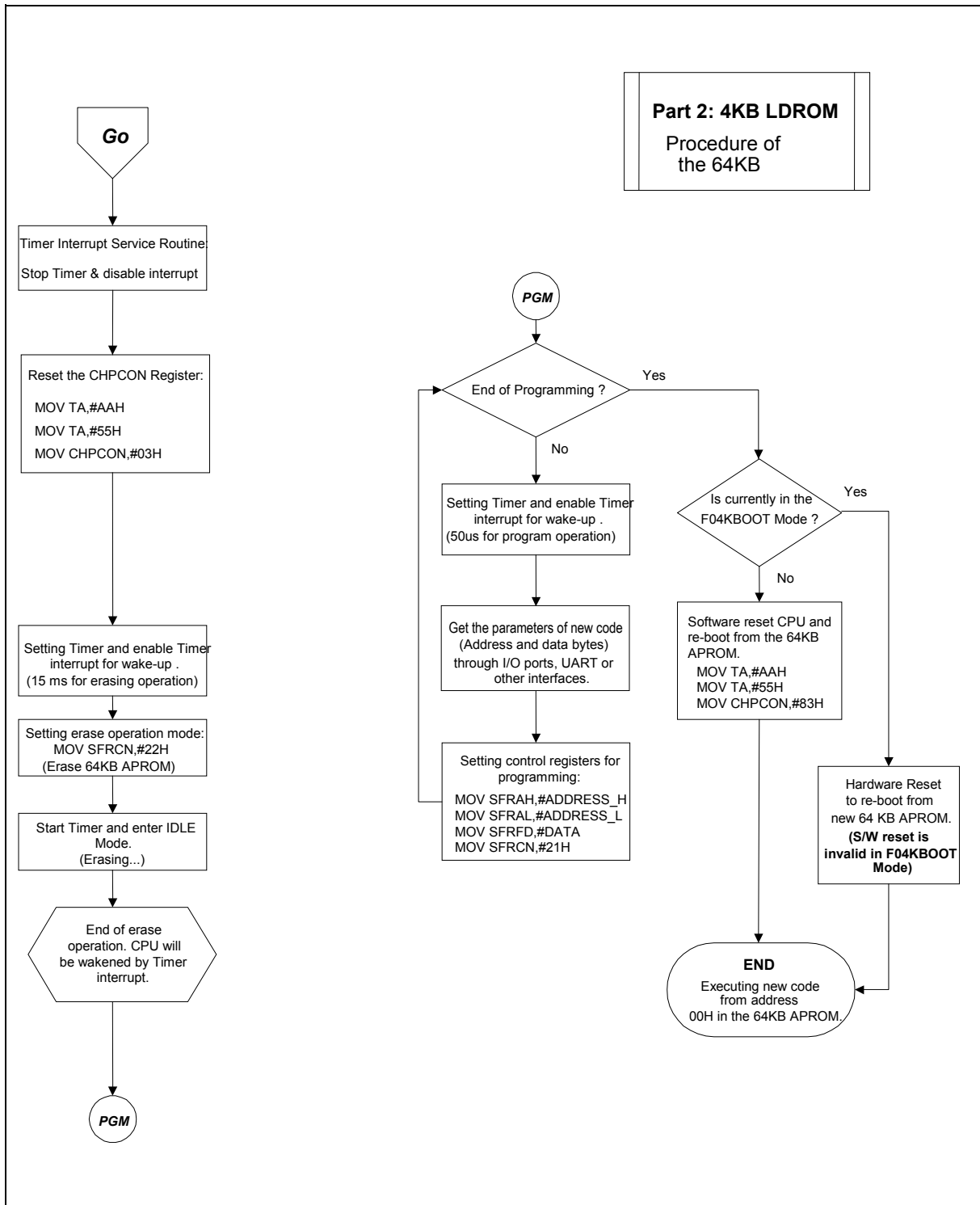



Application Note: In-system Programming Software Examples

This application note illustrates the in-system programmability of the Winbond W925EP01 Flash EPROM micro-controller. In this example, micro-controller will boot from 64 KB APROM bank and waiting for a key to enter in-system programming mode for re-programming the contents of 64 KB APROM. While entering in-system programming mode, micro-controller executes the loader program in 4KB LDROM bank. The loader program erases the 64 KB APROM then reads the new code data from external SRAM buffer (or through other interfaces) to update the 64KB APROM.

; EXAMPLE 1:

```

;*****
;
;* Example of 64K APROM program: Program will scan the P1.0. if P1.0 = 0, enters in-system
;* programming mode for updating the content of APROM code else executes the current ROM code.
;* XTAL = 4 MHz
;*****
;
        .chip 8052
        .RAMCHK OFF
        .symbols

CHPCON    EQU        EFH
TA        EQU        EEH
SFRAL     EQU        E4H
SFRAH     EQU        E5H
SFRFD     EQU        E6H
SFRCN     EQU        E7H

        ORG          0H
        LJMP 100H          ; JUMP TO MAIN PROGRAM
;*****
;
;*  TIMER0 SERVICE VECTOR ORG = 00BH

;*****
;*****

        ORG 00BH
        CLR  TR0          ; TR0 = 0, STOP TIMER0
        MOV  TL0,R6
        MOV  TH0,R7
        RETI
    
```

W925EP01/ W925EP01FG



```
.*****
;
;* 64K APROM MAIN PROGRAM
.*****
;
      ORG 100H

MAIN_64K:
      MOV A,P1          ; SCAN P1.0
      ANL A,#01H
      CJNE A,#01H,PROGRAM_64K ; IF P1.0 = 0, ENTER IN-SYSTEM
PROGRAMMING MODE
      JMP NORMAL_MODE

PROGRAM_64K:
      MOV TA,#AAH      ; TA = AAH, CHPCON REGISTER WRTE ENABLE
      MOV TA,#55H      ; TA = 55H, CHPCON REGISTER WRITE
ENABLE
      MOV CHPCON,#03H ; CHPCON = 03H, ENTER IN-SYSTEM
PROGRAMMING MODE
      MOV SFRCN,#00H   ; SFRCN = 00H
      MOV TCON,#00H    ; TR = 0 TIMER0 STOP
      MOV IP,#00H      ; IP = 00H
      MOV IE,#82H      ; TIMER0 INTERRUPT ENABLE FOR WAKE-UP
FROM IDLE MODE
      MOV R6,#F0H      ; TL0 = FEH
      MOV R7,#FFH      ; TH0 = FFH
      MOV TL0,R6
      MOV TH0,R7
      MOV TMOD,#01H    ; TMOD = 01H, SET TIMER0 A 16-BIT TIMER
      MOV TCON,#10H    ; TCON = 10H, TR0 = 1,GO
      MOV PCON,#01H    ; ENTER IDLE MODE FOR LAUNCHING THE IN-
SYSTEM
; PROGRAMMING
.*****
;Normal mode 64KB APROM program: depending user's application
.*****
;
; NORMAL_MODE:
```

W925EP01/ W925EP01FG



```

;
;
;           ; User's application program
;
;
;
;
;

; EXAMPLE 2:
;*****
;
;Example of 4KB LDROM program: This loader program will erase the 64KB APROM first, then reads
the new
;code from external SRAM and program them into 64KB APROM bank. XTAL = 4 MHz
;*****
;
;           .chip 8052
;           .RAMCHK OFF
;           .symbols

CHPCON    EQU    EFH
TA        EQU    EEH
SFRAL     EQU    E4H
SFRAH     EQU    E5H
SFRFD     EQU    E6H
SFRCN     EQU    E7H

;           ORG    000H
LJMP      100H    ; JUMP TO MAIN PROGRAM
;*****
;
;* 1. TIMER0 SERVICE VECTOR ORG = 0BH
;*****
;
;           ORG 000BH
;           CLR TR0           ; TR0 = 0, STOP TIMER0
;           MOV TL0,R6
;           MOV TH0,R7
;           RETI

;*****
;
;* 4KB LDROM MAIN PROGRAM
;*****
;
;           ORG 100H
```

W925EP01/ W925EP01FG



MAIN_4K:

```
MOV R4,#03H          ; ERROR COUNTER
MOV TA,#AAH          ; TA = AAH, CHPCON WRITE ENABLE.
MOV TA,#55H          ; TA = 55H, CHPCON WRITE ENABLE.
MOV CHPCON,#03H      ; CHPCON = 03H, ENABLE IN-SYSTEM
```

PROGRAMMING.

```
MOV SFRCN,#00H
MOV TA,#00H          ; DISABLE TA WRITE ATTRIBUTE
MOV TCON,#00H        ; TCON = 00H, TR = 0 TIMER0 STOP
MOV TMOD,#01H        ; TMOD = 01H, SET TIMER0 A 16BIT TIMER
MOV IP,#00H          ; IP = 00H
MOV IE,#82H          ; IE = 82H, TIMER0 INTERRUPT ENABLED
MOV R6,#F0H
    MOV R7,#FFH
MOV TL0,R6
MOV TH0,R7
MOV TCON,#10H        ; TCON = 10H, TR0 = 1, GO
MOV PCON,#01H        ; ENTER IDLE MODE
```

UPDATE_64K:

```
MOV TCON,#00H        ; TCON = 00H , TR = 0 TIM0 STOP
MOV IP,#00H          ; IP = 00H
MOV IE,#82H          ; IE = 82H, TIMER0 INTERRUPT ENABLED
MOV TMOD,#01H        ; TMOD = 01H, MODE1
MOV R6,#D0H          ; SET WAKE-UP TIME FOR ERASE OPERATION, ABOUT
15 mS. DEPENDING
; ON USER'S SYSTEM CLOCK RATE.
```

```
MOV R7,#8AH
MOV TL0,R6
MOV TH0,R7
```

ERASE_P_4K:

```
MOV SFRCN,#22H        ; SFRCN(E7H) = 22H ERASE 64K
MOV TCON,#10H        ; TCON = 10H, TR0 = 1,GO
```



```
MOV PCON,#01H      ; ENTER IDLE MODE (FOR ERASE OPERATION)
```

```
.*****
;
```

```
;* BLANK CHECK
```

```
.*****
;
```

```
MOV SFRCN,#0H      ; READ 64KB APROM MODE
MOV SFRAH,#0H      ; START ADDRESS = 0H
MOV SFRAL,#0H
MOV R6,#FDH        ; SET TIMER FOR READ OPERATION, ABOUT 1.5 mS.
MOV R7,#FFH
MOV TL0,R6
MOV TH0,R7
```

```
BLANK_CHECK_LOOP:
```

```
SETB TR0           ; ENABLE TIMER 0
MOV PCON,#01H      ; ENTER IDLE MODE
MOV A,SFRFD        ; READ ONE BYTE
CJNE A,#FFH,BLANK_CHECK_ERROR
INC SFRAL          ; NEXT ADDRESS
MOV A,SFRAL
JNZ BLANK_CHECK_LOOP
INC SFRAH
MOV A,SFRAH
CJNE A,#0H,BLANK_CHECK_LOOP ; END ADDRESS = FFFFH
JMP PROGRAM_64KROM
```

```
BLANK_CHECK_ERROR:
```

```
MOV P1,#F0H
MOV P3,#F0H
JMP $
```

```
.*****
;
```

```
;RE-PROGRAMMING 64KB APROM BANK
```

```
.*****
;
```

```
PROGRAM_64KROM:
```

```
MOV R2,#00H        ; TARGET LOW BYTE ADDRESS
MOV R1,#00H        ; TARGET HIGH BYTE ADDRESS
```

W925EP01/ W925EP01FG



```
MOV DPTR,#0H ; EXTERNAL SRAM BUFFER ADDRESS
MOV SFRAH,R1 ; SFRAH, TARGET HIGH ADDRESS
MOV SFRCN,#21H ; SFRCN(C7H) = 21 (PROGRAM 64K)
MOV R6,#9CH ; SET TIMER FOR PROGRAMMING,
ABOUT 50 mS.
MOV R7,#FFH
MOV TL0,R6
MOV TH0,R7
```

PROG_D_64K:

```
MOV SFRAL,R2 ; SFRAL(E4H) = LOW BYTE ADDRESS
CALL GET_BYTE_FROM_PC_TO_ACC ; THIS FUNCTION CALL IS BASE
ON USER'S CIRCUIT
MOVX @DPTR,A ;SAVE DATA TO EXTERNAL SRAM
BUFFER
MOV SFRFD,A ; SFRFD(E6H) = DATA IN
MOV TCON,#10H ; TCON = 10H, TR0 = 1,GO
MOV PCON,#01H ; ENTER IDLE MODE (PRORGAMMING)
INC DPTR
INC R2
CJNE R2,#0H,PROG_D_64K
INC R1
MOV SFRAH,R1
CJNE R1,#0H,PROG_D_64K
```

.*****

; * VERIFY 64KB APROM BANK

.*****

```
MOV R6,#FDH ; SET TIMER FOR READ VERIFY, ABOUT 1.5 mS.
MOV R7,#FFH
MOV TL0,R6
MOV TH0,R7
MOV DPTR,#0H ; The start address of sample code
MOV R2,#0H ; Target low byte address
MOV R1,#0H ; Target high byte address
MOV SFRAH,R1 ; SFRAH, Target high address
MOV SFRCN,#00H ; SFRCN = 00 (Read ROM CODE)
```



READ_VERIFY_64K:

```
MOV SFRAL,R2      ; SFRAL(E4H) = LOW ADDRESS
MOV TCON,#10H    ; TCON = 10H, TR0 = 1,GO
MOV PCON,#01H
INC R2
MOVX A,@DPTR
INC DPTR
CJNE A,SFRFD,ERROR_64K
CJNE R2,#0H,READ_VERIFY_64K
INC R1
MOV SFRAH,R1
CJNE R1,#0H,READ_VERIFY_64K
```

```
.*****
;
;* PROGRAMMING COMPLETELY, SOFTWARE RESET CPU
.*****
```

```
MOV TA,#AAH      ; TA = AAH
MOV TA,#55H      ; TA = 55H
MOV CHPCON,#83H  ; CHPCON = 83H, SOFTWARE RESET.
```

ERROR_64K:

```
DJNZ R4, UPDATE_64K ; IF ERROR OCCURS, REPEAT 3 TIMES.
; IN-SYSTEM PROGRAMMING FAIL, USER'S
PROCESS TO DEAL WITH IT.
```



6.19 Security Bits

Using device programmer, the Flash EPROM can be programmed and verified repeatedly. Until the code inside the Flash EPROM is confirmed OK, the code can be protected. The protection of Flash EPROM and those operations on it are described below. The W925EP01 has Special Setting Register, which can be accessed by device programmer. The register can only be accessed from the Flash EPROM operation mode. Those bits of the Security Registers cannot be changed once they have been programmed from high to low. They can only be reset through erase-all operation.

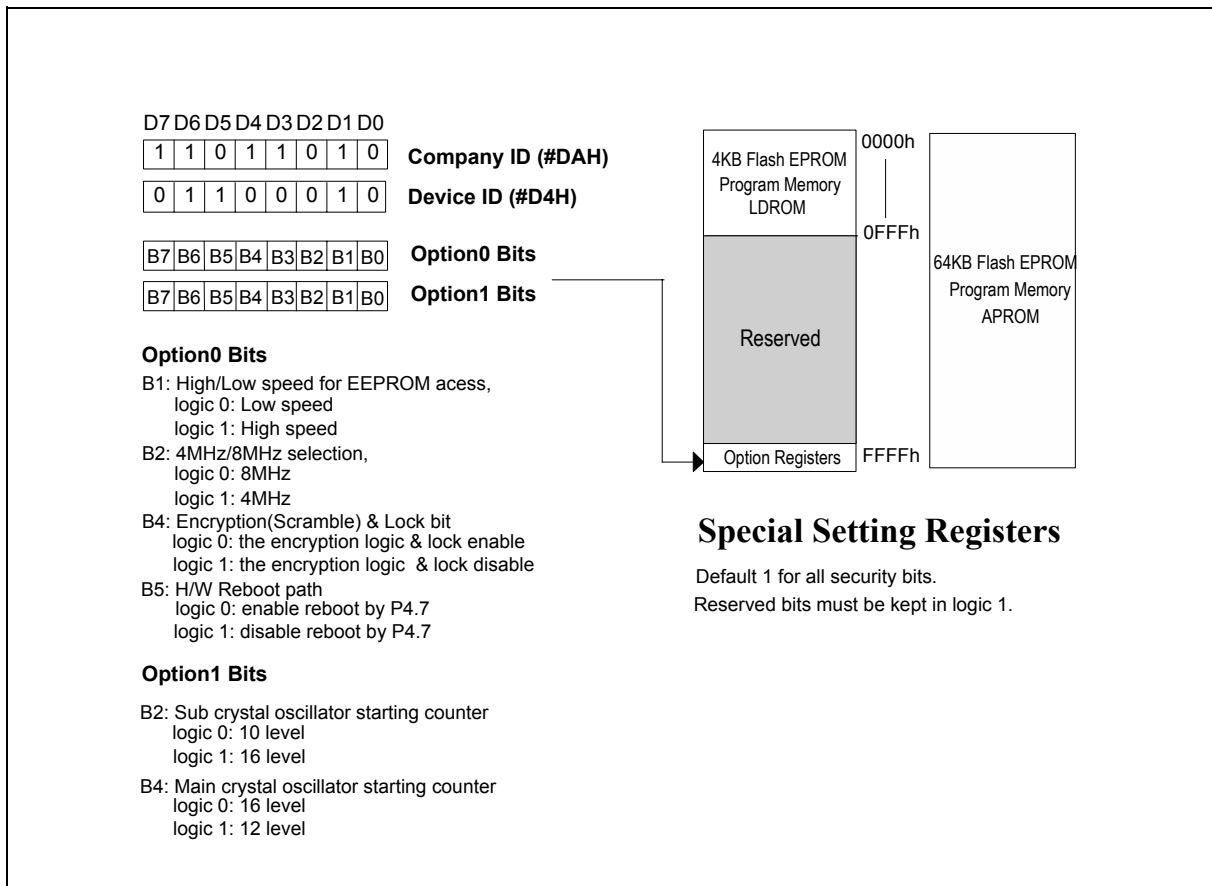

Option0:

B1: High/Low speed for EEPROM access

B2: 4M/8MHz oscillator selection

If this bit is set to logic 0, the oscillator will operate at 8MHz.

If this bit is set to logic 1, the oscillator will operate at 4MHz.

B4: Encryption(Scramble) & Lock bit

This bit is used to protect the customer's program code. It may be set after the programmer finishes the programming and verifies sequence. Once this bit is set to logic 0, both the Flash EPROM data and Special Setting Registers cannot be accessed again.



This bit is also used to enable/disable the encryption logic for code protection. Once encryption feature is enabled, the data presented on Data0~7 will be encoded via encryption logic. Only whole chip erase will reset this bit.

B5: P4.7 H/W Reboot function

If this bit is set to logic 0, it will enable P4.7 to reboot.

Option1:

B2: Sub Crystal Oscillator Starting Counter

If this bit is set to logic 0, it will delay 10 levels from crystal starting.

IF THIS BIT IS SET TO LOGIC 1, IT WILL DELAY 16 LEVELS FROM CRYSTAL STARTING.

B4: Main Crystal Oscillator Starting Counter

If this bit is set to logic 0, it will delay 16 levels from crystal starting.

IF THIS BIT IS SET TO LOGIC 1, IT WILL DELAY 12 LEVELS FROM CRYSTAL STARTING.



6.20 Calling Identity Delivery (CID)

W925EP01 provides type I and type II of CID system. Type I is on-hook calling with CID message and type II is off-hook call on waiting. The CID function includes FSK decoder, dual tone alert signal detector, ring detector and DTMF receiver. The FSK demodulation function can demodulate Bell 202 and ITU-T V.23 Frequency Shift Keying (FSK) with 1200-baud rate. The Tone Alert Signal detect function can detect dual tones of Bellcore Customer Premises Equipment(CPE) Tone Alerting Signal(CAS) and BT Idle State and Loop State Tone Alert Signal. The line reversal for BT, ring burst for CCA or ring signal for Bellcore can be detected by ring detector. It is compatible with Bellcore TR-NWT-000030 & ST-TSV-002476, British Telecom(BT) SIN227, U.K. Cable Communications Association(CCA) specification. The DTMF receiver can be programmed as DTMF decoder to decode 16 DTMF signals or tone detector to detect the signal which frequency is in DTMF band. The tone detector can be an auxiliary detector to improve the performance of detecting tone-alerting signal(CAS), said as talk down-off, in type II system.

The FSK decoder, alert tone detector and DTMF receiver can be enable/disable individually by the bits of FSKE, CASE and DTMFE in FSK DATA REGISTER(FSKDR). CIDE is the global control bit to enable/disable FSK decoder, alert tone detector and DTMF receiver. However, the ring detector is always active.

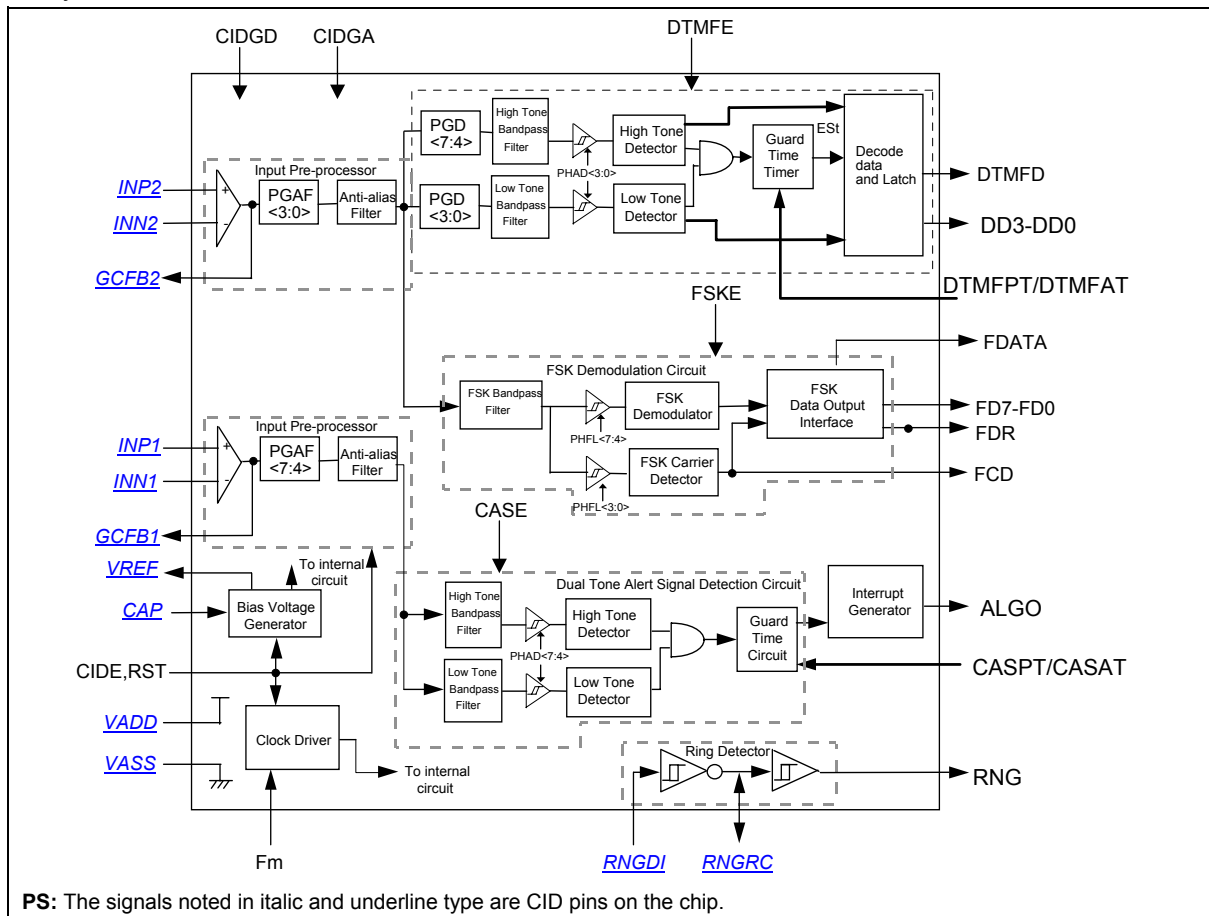

Figure 6-12 The CID Block Diagram

Ring Detector

The application circuit in Figure 6-13 illustrates the relationship between the RNGDI, RNGRC and RNG signals. The combination of RNGDI and RNGRC is used to detect an increase of the RNGDI voltage from ground to a level above the Schmitt trigger high going threshold voltage V_{T+} .

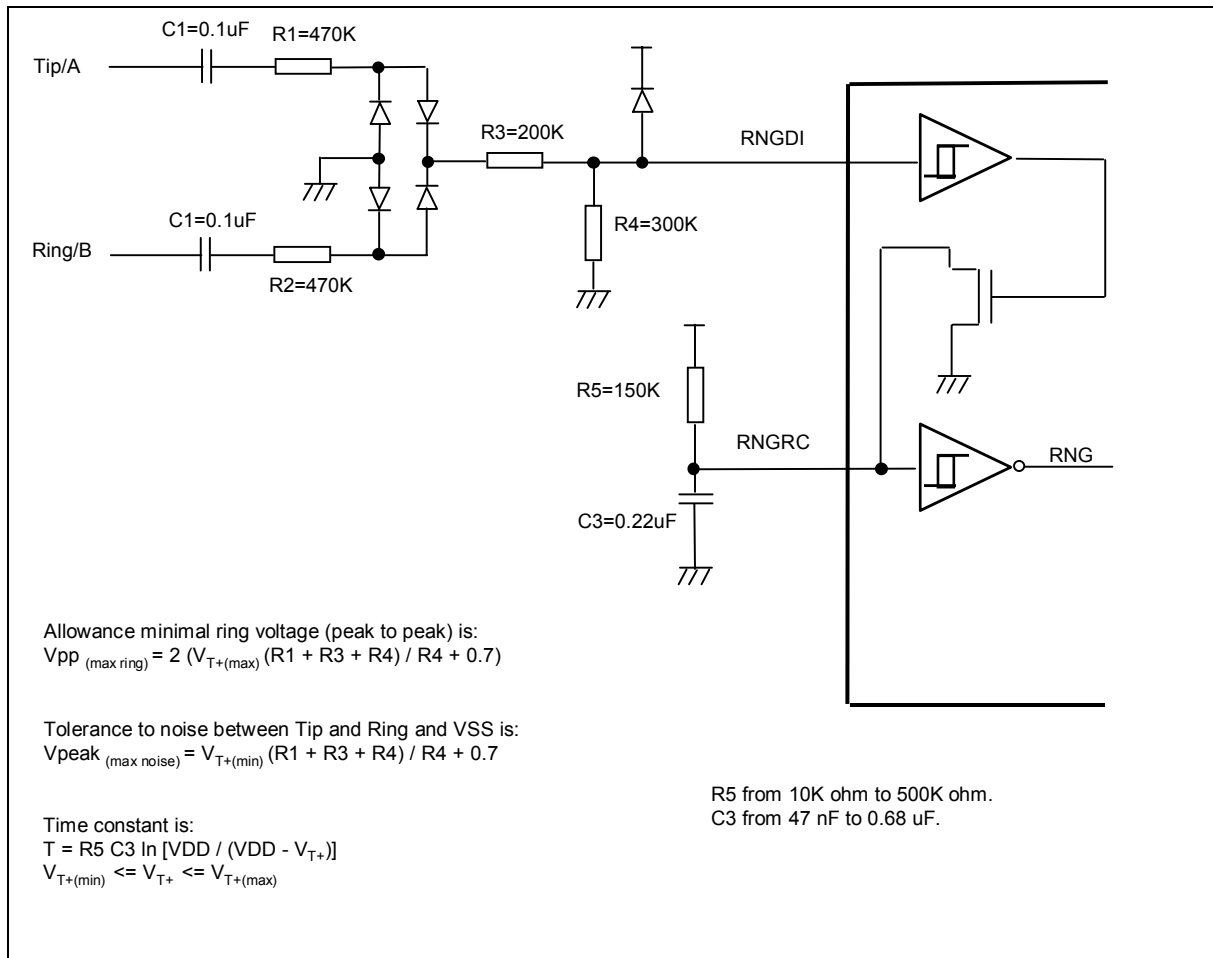

Figure 6-13 Application Circuit of the Ring Detector

The RC time constant of the RNGRC pin is used to delayed the output pulse of the RNG flag for a low going edge on RNGDI. This edge goes from above the V_{T+} voltage to the Schmitt trigger low going threshold voltage V_{T-} . The RC time constant must be greater than the maximum period of the ring signal, to ensure a minimum RNG high interval and to filter the ring signal to get an envelope output. The rising signal of RNG will set the bit RNGF(CIDFG.0) high to cause the CID flag(CIDF) high.

The diode bridge shown in Figure 6-13 works for both single ended ring signal and balanced ringing. The R1 and R2 are used to set the maximum loading and must be of equal value to achieve balanced loading at both the tip and ring line. R1, R3 and R4 form a resistor divider to supply a reduced voltage to the RNGDI input. The attenuation value is determined by the detection of minimal ring voltage and maximum noise tolerance between tip/ring and ground.

Input Pre-Processor

The input signal is processed by Input Pre-Processor, which is comprised of two OP amps and a bias source(VREF). The gain OP-amps are used to bias the input voltage with the VREF signal voltage. VREF is $V_{AD}/2$ typically, this pin is recommended to connect a 0.1uF capacitor to V_{AS} . The gain adjustable OP amps are sued to select the input gain by connecting a feedback resistor between GCFB and INN pins. Figure 6-14 shows the differential input configuration and Figure 6-15 shows the single-ended configuration.

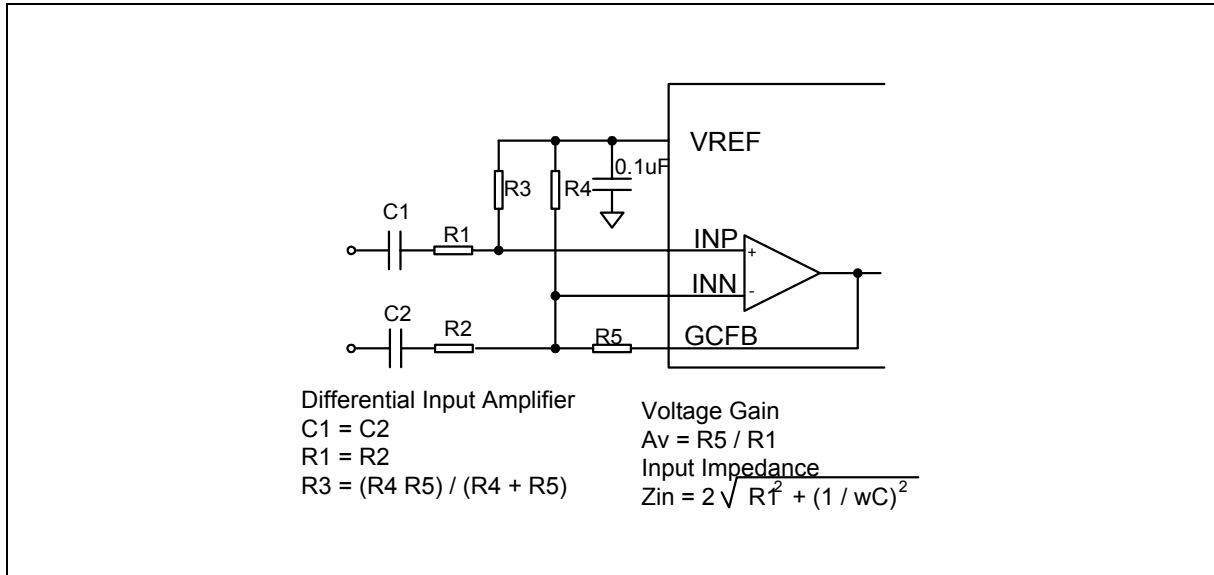

Figure 6-14 Differential Input Gain Control Circuit

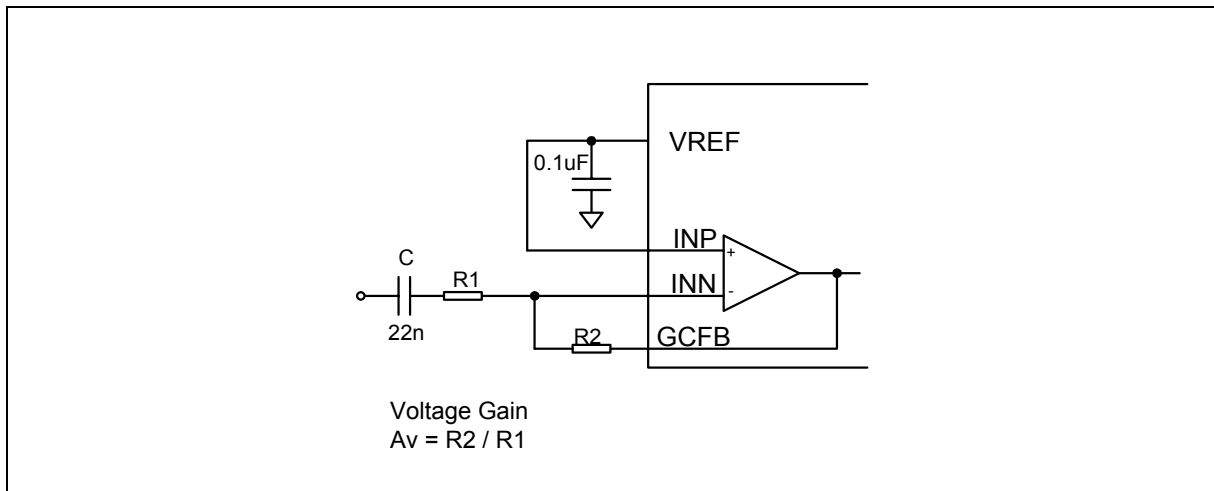

Figure 6-15 Single-Ended Input Gain Control Circuit

CAS/DTAS Detection

In off-hook services (type II), the detection of CAS/DTAS will affect the quality of the call waiting service. When the CAS/DTAS is sent from far end, sometimes the near end user maybe still talking. The CPE must be able to detect the CAS/DTAS successfully in the presence of near end speech. To detect CAS/DTAS from telephone hybrid receiver pair improves the detection. However, in BT's on-hook CID system the CAS/DTAS detection is from Tip/Ring pair.

The dual tone alert signal is separated into high and low tones and detected by a high/low tone detector. When the alert tone is recognized by the detector, the bit ALGO will go high and the rising signal will set the bit ALGOF in CIDFG to produce the CID flag(CIDF). Figure 6-16 shows the guard time waveform of detecting alert tone. The total recognition time is $t_{REC}=t_{DP}+t_{GP}$, where t_{DP} is the tone present detect time and t_{GP} is the tone present guard time. The total absent guard time is $t_{ABS}=t_{DA}+t_{GA}$ where t_{DA} is the tone absent detect time and t_{GA} is the tone absent guard time. The tone present/absent guard time is determined by guard-time timer, which the input clock period is 0.858mS. When the alert tone is detected, the internal signal ALGR will be set and the rising edge of ALGR resets the guard-time timer and the timer starts up counting from 00H. As the content of the timer is the same as the register CASPT, the timer stops counting and the bit ALGO will be set and the rising edge of ALGO triggers the flag ALGOF to become high. The counting of tone absent time is similar to the counting of tone present time but the falling edge of ALGR/ ALGO replaces the rising edge and the CASAT replaces the CASPT. The bit ALGO is controlled by hardware only. The flag ALGOF is set by rising edge of ALGO and cleared by software.

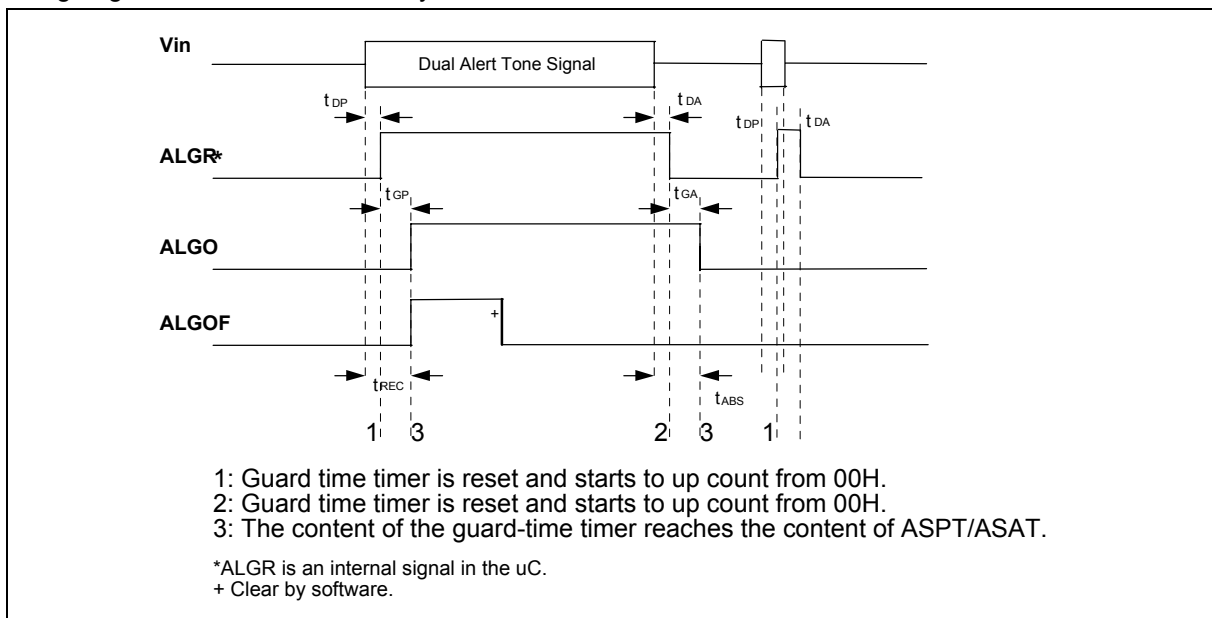

Figure 6-16 Guard Time Waveform of Alert Tone Signal Detection

DTMF Decoder

The DTMF decoder shares the same input pre-processor with FSK decoder. The dual tone is separated into low group and high group by two SCFs (switched capacitor filter). The method of DTMF detection is the same as alert tone detection. The present/absent guard time can adjust by registers DTMFPT/DTMFAT. As the DTMF signal is recognized and decoded, the bit DTMFD will be set and the decoded DTMF data is stored in bit0 to bit3 of register DTMFDR. The rising edge of DTMFD produces the flag DTMFDF. The bit DTMFD is controlled by hardware only. The flag DTMFDF is set by rising edge of DTMFD and cleared by software.

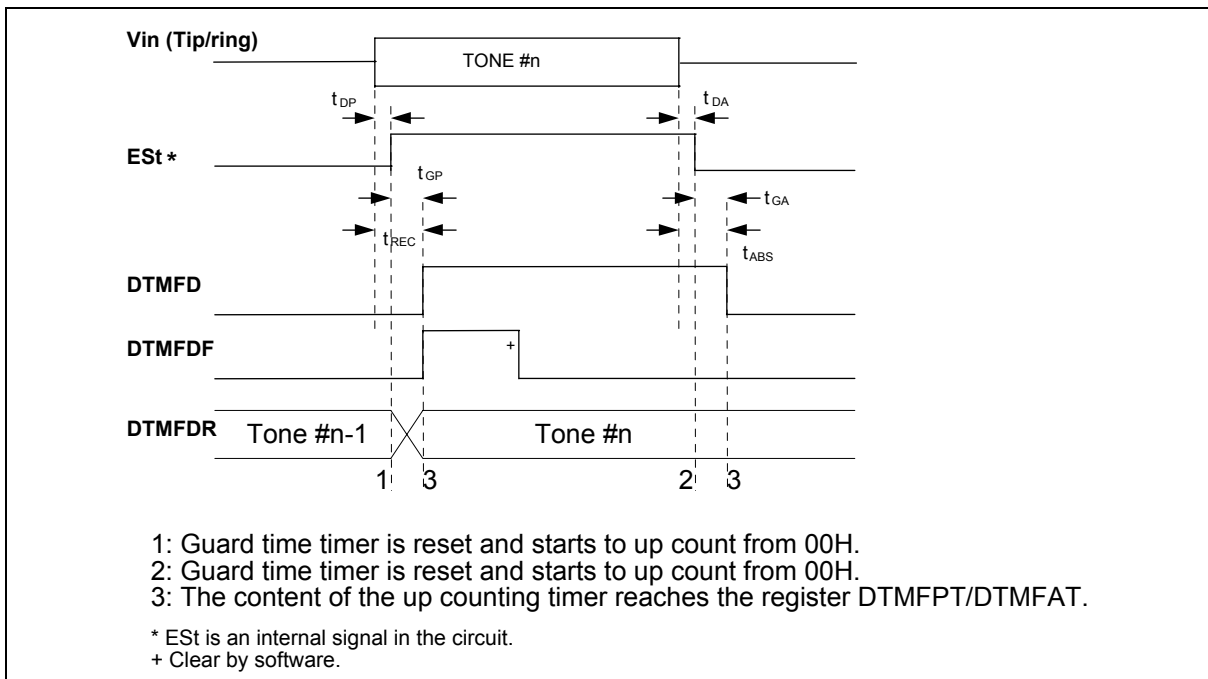

Figure 6-17 The Waveform of DTMF Detection

Tone Detector

In off-hook state, said type II system, detecting tone alert signal (CAS) is easily interfered by human's voice or other noise in voice band. Sometimes the interference makes falsely recognizing a noise as a CAS (talk-off), or lost detecting a real CAS (talk-down). The DTMF can be programmed as a tone detector by setting bit 4 of DTMFR2. The frequency band of the tone detector is DTMF frequency from 697Hz to 1633Hz. Once the tone detector gets signals in the band, the bit of DTMFH or DTMFL in register DTMFDR will become high immediately. User can poll these 2 bits to check if the tone exists on the tip/ring. The input gain of tone detector is the same as DTMF receiver.

FSK Decoder

The FSK carrier detector provides an indication of the present of a signal within the FSK frequency band. If the output amplitude of the FSK band-pass filter is sufficient to be detected continuously for 8 mS, the FSK carrier detected bit FCD will go high and it will be released if the FSK band-pass filter output amplitude is not able to be detected for greater than 8 mS. The 8 mS is the hysteresis of the FSK carrier detector. Figure 6-18 shows the timing of FSK carrier detection.

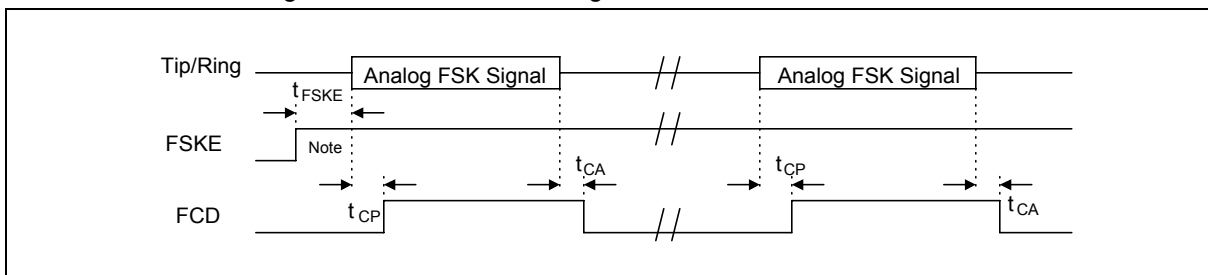

Figure 6-18 FSK Detection Enable and FSK Carrier Present and Absent Timing



The FSK demodulation function can demodulate Bell 202 and ITU-T V.23 Frequency Shift keying (FSK) with 1200-baud rate. When the decoder receives the FSK serial data, the serial data will be demodulated into bit FDATA with 1200-baud rate in the mean time the synchronous clock signal is output to the bit FCLK. As the decoder receives one byte, the internal serial-to-parallel circuit sets the bit FDR and converts the 8-bit serial data into the byte register FSKDR. The rising edge of bit FDR will set the flag FDRF to produce CID interrupt but FDRF is cleared by software. User can get the FSK data by reading register FSKDR or sampling the bit FDATA. The timing of FSK demodulation is shown in Figure 6-19.

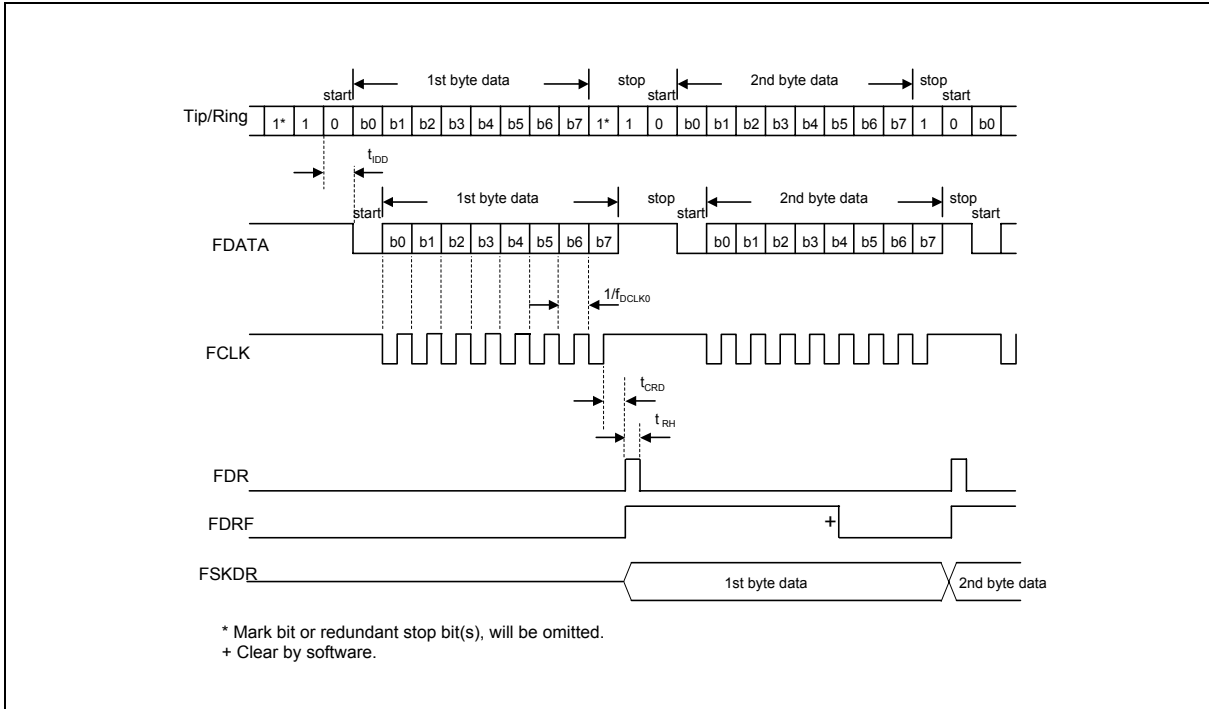

Figure 6-19 Serial Data Interface Timing of FSK Demodulation

CID Input Gain Control

The CID input gain and input hysteresis are controllable by internal CID gain control registers. CIDGD and CIDGA registers determine the 6 internal CID gain control registers. CID gain control data register (CIDGD) presents the data bus. The lower 3 bits of CID gain control address register (CIDGA) present the address. The rising edge of CIDGA.4 will latch the CIDGD in the corresponding internal CID gain control register. The 6 internal CID gain control registers are addressed as following table. Setting the 6 registers as the suggestion value guarantees the CID spec.

ADDRESS (CIDGA.2-0)	INTERNAL CID GAIN CONTROL REGISTER	SUGGESTION VALUE
000	DTMFR1: DTMF register1	0000 0001B
001	DTMFR2: DTMF register2	011X 0001B[†]
002	PGAF: Programmable gain control alert tone and FSK	99H
003	PGAD: Programmable gain control DTMF	A7H
004	PHAD: Programmable hysteresis alert tone and DTMF	35H
005	PHFL: Programmable hysteresis FSK and low pass filter	33H

[†] X=0 DTMF receiver works a DTMF decoder, X=1 DTMF receiver works as a tone detector.

The signals to set internal CID gain control registers is shown in Figure 6-20

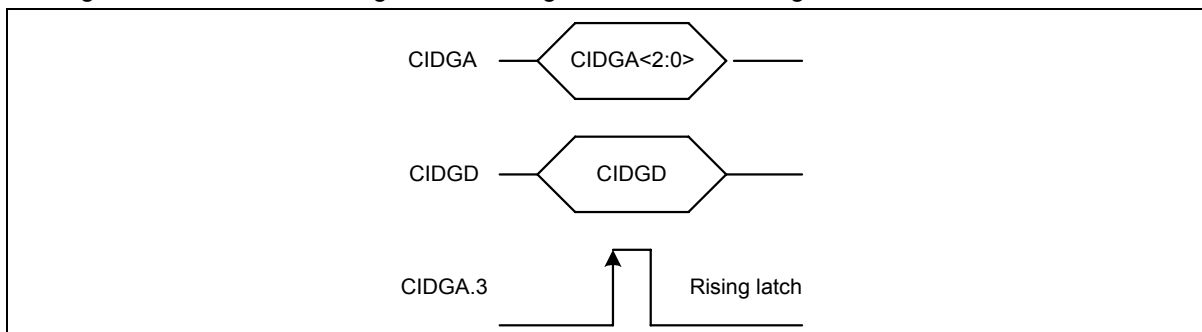

Figure 6-20 Internal CID Gain Control Register Setting Waveform

DTMFR1

DTMFR1 [7:4] are reserved bits and must be 0000b.

BIT3~BIT0	ACCEPTABLE ERROR PERCENTAGE TO SAMPLE 4 PERIOD OF ROW FREQ.
0000	0.6% (default)
0001	2.5%
001X	3.5%
01XX	Reserved
1XXX	Reserved

DTMFR2

BIT3~BIT0	ACCEPTABLE ERROR PERCENTAGE TO SAMPLE 4 PERIOD OF COL FREQ.
0000	0.5% (default)
0001	1.5%
001X	2.5%
01XX	Reserved
1XXX	Reserved

The acceptable error percentage may have small variation by different test environments.

W925EP01/ W925EP01FG



DTMFR2.4=0	DTMF receiver works as a DTMF receiver
DTMFR2.4=1	DTMF receiver works as a tone detector
DTMFR2.5=0	DTMF PT counter is up counter type, detected frequency changed does not effect counter
DTMFR2.5=1	DTMF PT counter is up counter type, detected frequency changed resets DTMF PT counter
DTMFR2.6=0	DTMF AT counter is up-down counter type, up counting when no DTMF detected, down counting if DTMF detected again.
DTMFR2.6=1	DTMF AT counter is up counter type, up counting when no DTMF detected, pause counting if DTMF detected again.
DTMFR2.7: reserved	

There are 4 programmable gain arrays, shown in Figure 6-12, are determined by Low/High nibbles of PGxx. The following table lists the input gain corresponding to the value of L/H nibble of PGxx.

X	$20 \text{ LOG}((40+15*X)/(230-(40+15*X))) \text{ DB}$	X	$20 \text{ LOG}((40+15*X)/(230-(40+15*X))) \text{ DB}$
0	-13.53	6	2.28
1	-10.05	7	4.64
2	-7.18	8	7.18
3	-4.64	9	10.05
4	-2.28	10	13.53
5	0.00	X is the value of L/H nibble of PGxx	

There are 4 programmable hysteresis input buffer, shown in Figure 6-12, are determined by Low/ High nibbles of PHxx. The hysteresis control formulas are list below.

Alert tone hysteresis	$HAT=13\text{mv} + 3\text{mv}*X$	$X=\text{PHAD}\langle 7:4 \rangle$
DTMF hysteresis	$HDTMF=6\text{mv} + 3\text{mv}*X$	$X=\text{PHAD}\langle 3:0 \rangle$
FSK hysteresis	$HFSK=13\text{mv} + 3\text{mv}*X$	$X=\text{PHFL}\langle 7:4 \rangle$
FSK detector hysteresis	$HFSKD=13\text{mv} + 3\text{mv}*X$	$X=\text{PHFL}\langle 3:0 \rangle$

Application Circuit

The analog interface circuit of W925EP01 shown in Figure 6-21 is a typical CPE system. The gain control op-amp is set to unit gain to allow the electrical characteristics to be met in this application circuit.

W925EP01/ W925EP01FG

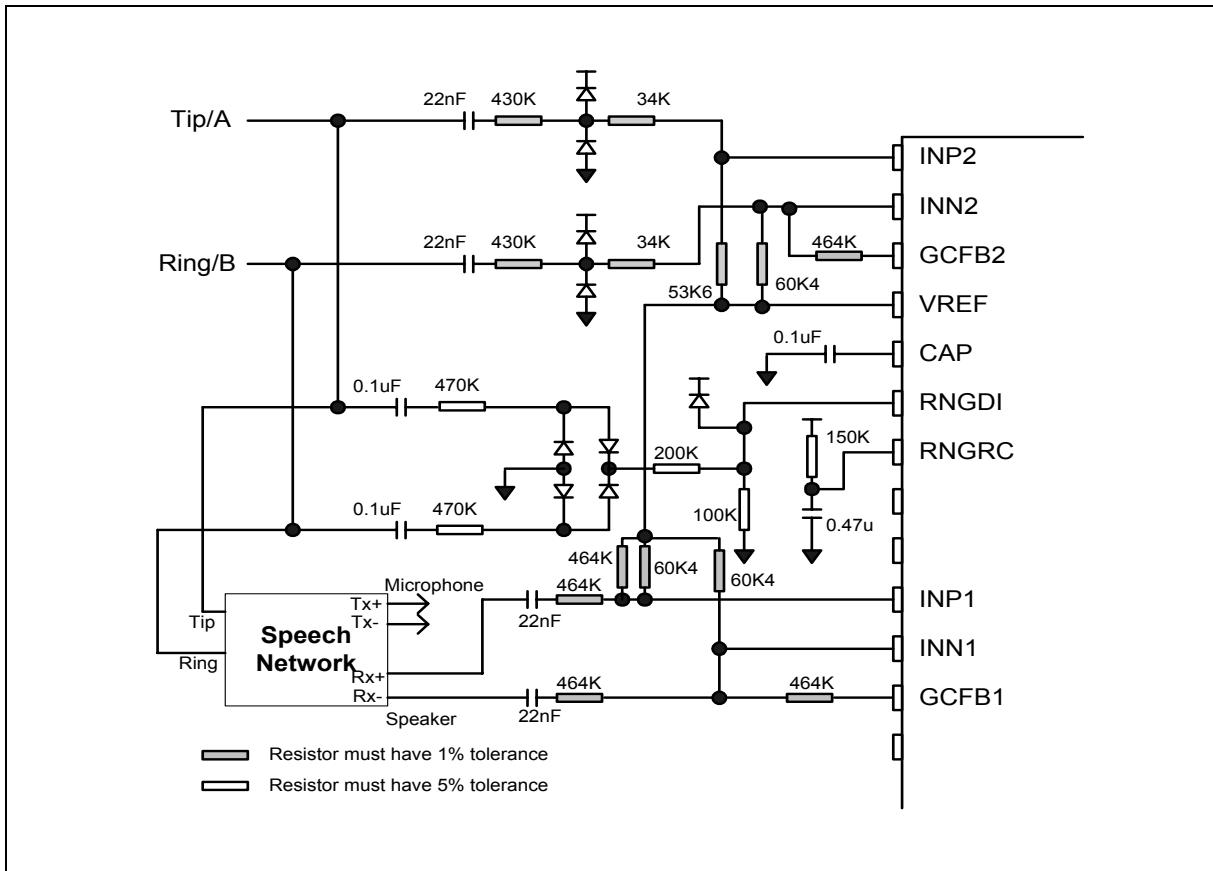

Figure 6-21 Application Circuit of CID



Application Environment

There are three major timing differences for CID sequences, Bellcore, BT and CCA. Figure 6-22 is the timing diagram for Bellcore on-hook data transmission and Figure 6-23 is the timing diagram for the Bellcore off-hook data transmission. Figure 6-24 is the timing diagram for the BT caller display service on-hook data transmission and Figure 6-25 is the timing diagram for the BT caller display service off-hook data transmission. Figure 6-26 is the timing diagram for the CCA caller display service for on-hook data transmission. The CID flag (CIDF) must be cleared by software when each time the CID interrupt routine is serviced. The CID global enable signal (CIDE) must be set high.

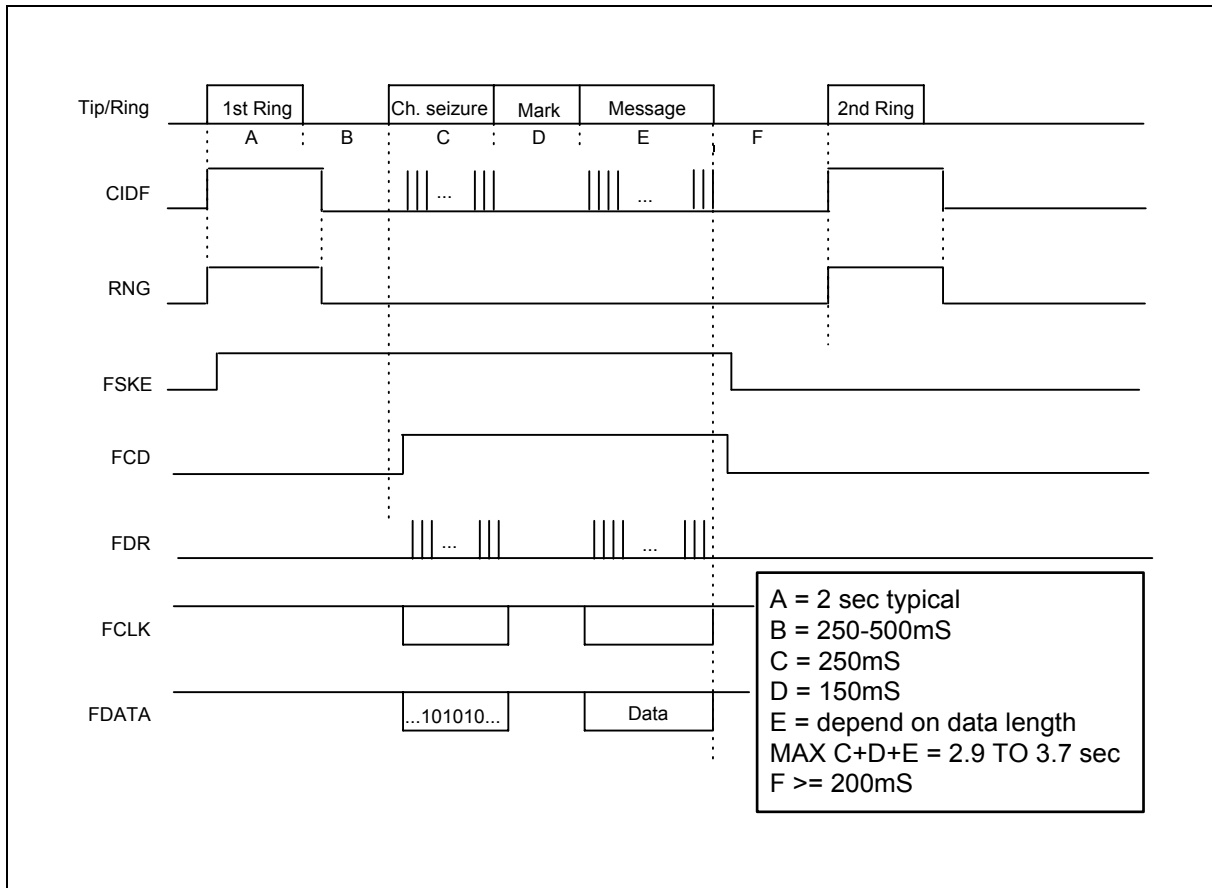

Figure 6-22 Input and Output Timing of Bellcore On-hook Data Transmission

W925EP01/ W925EP01FG

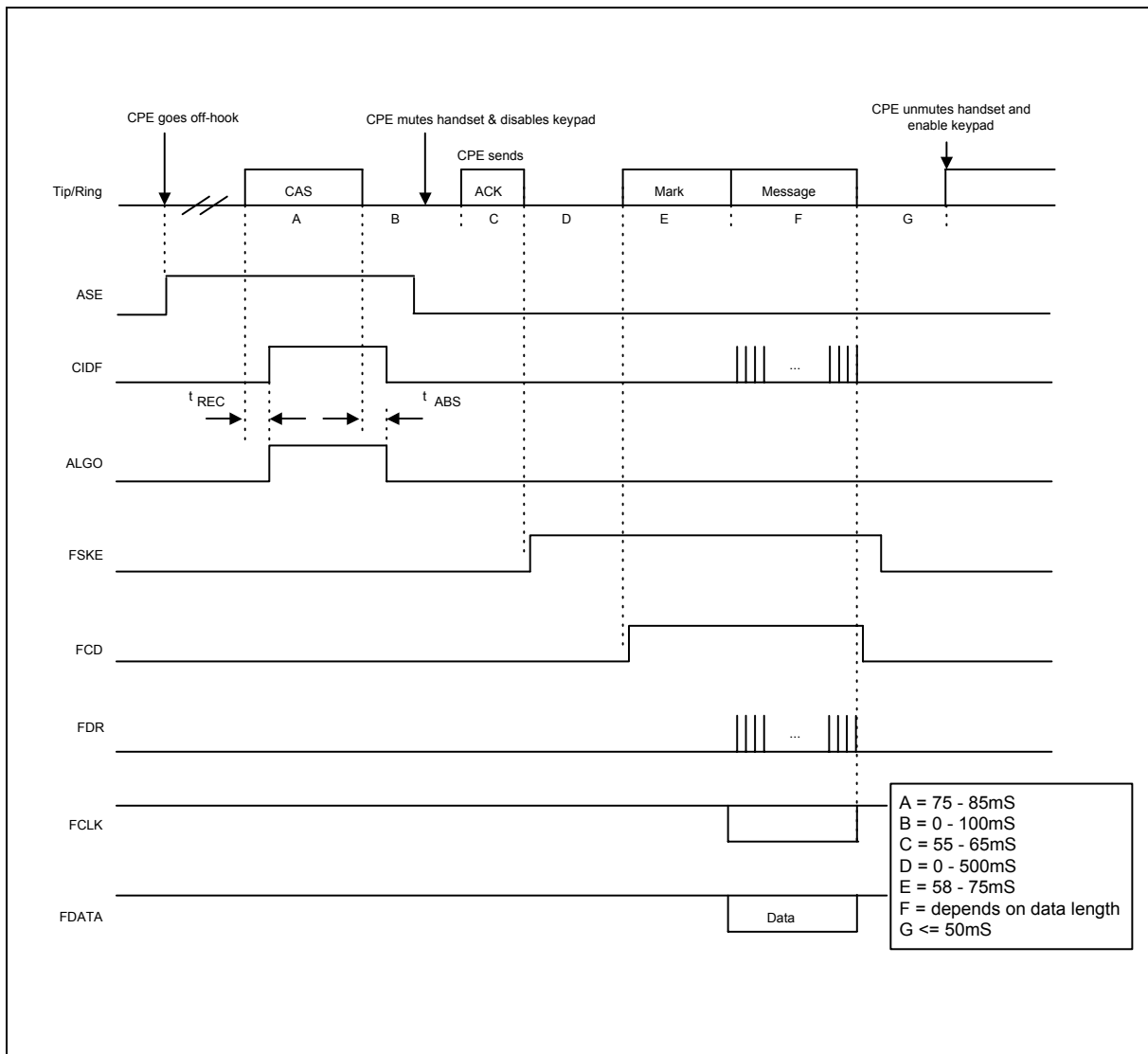

Figure 6-23 Input and Output Timing of Bellcore Off-hook Data Transmission

W925EP01/ W925EP01FG

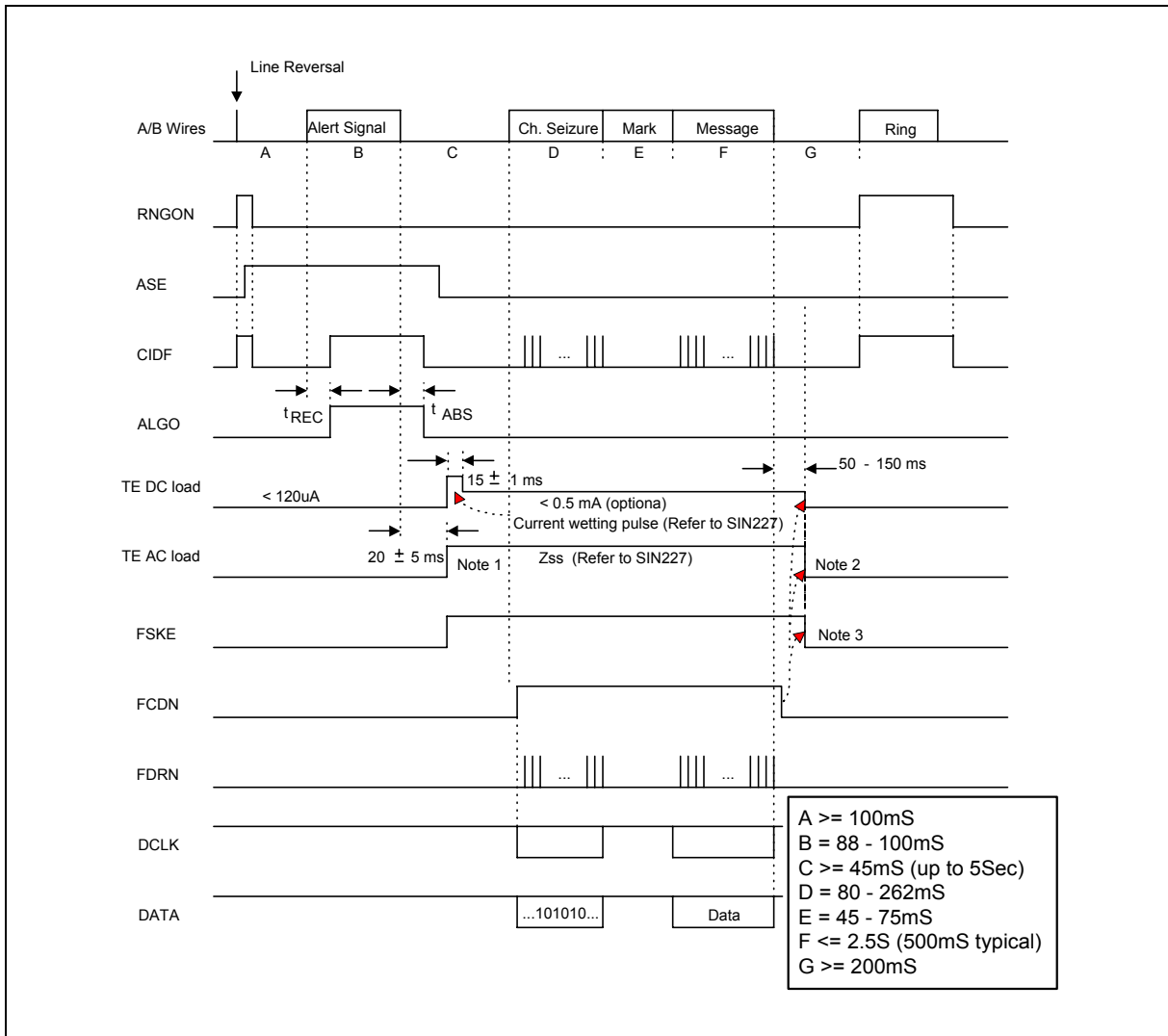

Figure 6-24 Input and Output Timing of BT Idle State (On-hook) Data Transmission

Note:

1. SIN227 specifies that the AC and DC loads should be applied at 20 ± 5 ms after the end of the dual tone alert signal.
2. SIN227 specifies that the AC and DC loads should be removed between 50 – 150ms after the end of the FSK signal.
3. The FSKE bit should be set low to disable the FSK decoder when FSK is not expected. The tone alerting signal speech and the DTMF tones are in the same frequency band as the FSK signal.

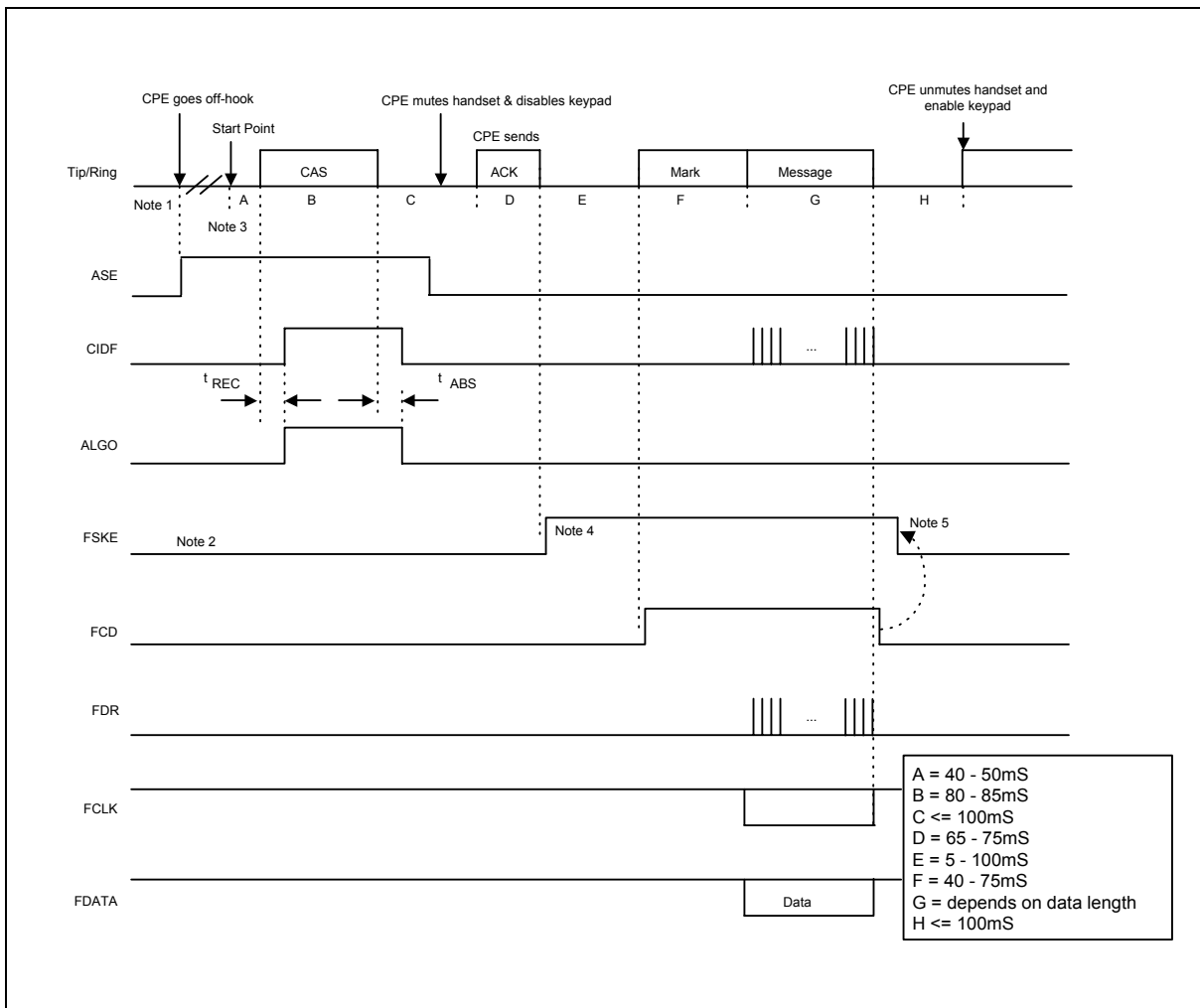

Figure 6-25 Input and Output Timing of BT Loop State (Off-hook) Data Transmission

Note:

1. In a CPE where AC power is not available, the designer may choose to switch over to line power when the CPE goes off-hook and use battery power while on-hook.
2. The FSKE bit may be set low to prevent the alert tone, speech or other FSK in-band noise decoded by FSK demodulator and give false data when the dual tone alert signal is expected. If the FSKE pin cannot controlled by micro-controller, the FSKE bit must always placed in high state and the micro controller must give up the FSK decoded data when the FSK signal is not expected.
3. The exchange will have already disabled the speech path to the distant customer in both transmission directions.
4. The FSKE should be set high as soon as the CPE has finished sending the acknowledge signal ACK.
5. The FSKE may be set low after the last byte (check sum) has been decoded or FCD has become inactive.
6. In an unsuccessful attempts where the exchange does not send the FSK signal, the CPE should disable FSKE, un-mute the handset and enable the keypad after this interval.

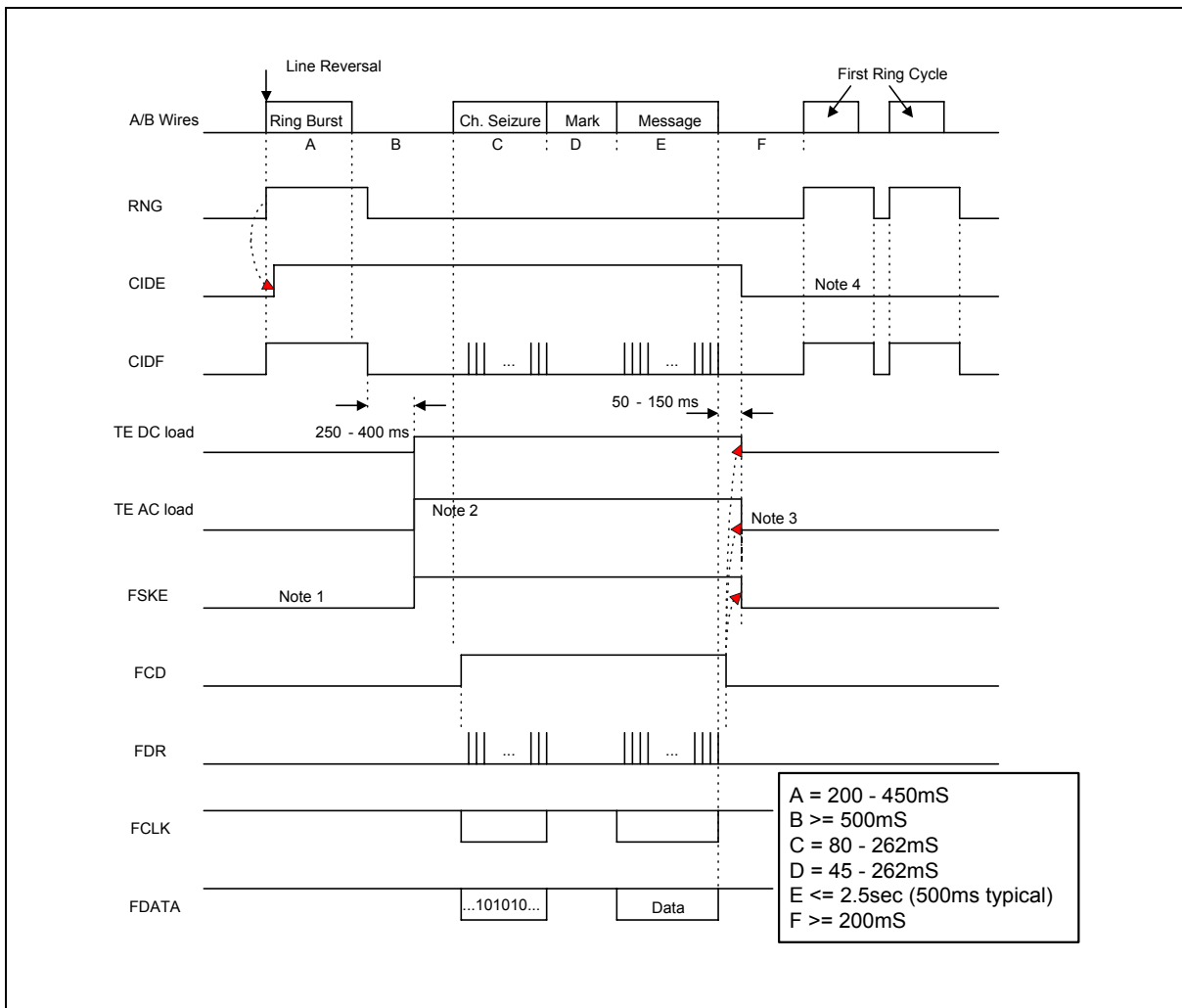

Figure 6-26 Input and Output Timing of CCA Caller Display Service Data Transmission

Notes:

1. The CPE designer may choose to set FSKE always high while the CPE is on-hook and the FSK signal is expected.
2. TW/P & E/312 specifies that the AC and DC loads should be applied between 250 - 400 mS after the end of the ring burst.
3. TW/P & E/312 specifies that the AC and DC loads should be removed between 50 - 150 ms after the end of the FSK signal.
4. The CID may not be enable up at the first ring cycle after the FSK data had been processed.



7. TIMING WAVEFORMS

Program Fetch Cycle(Two Machine Cycle)

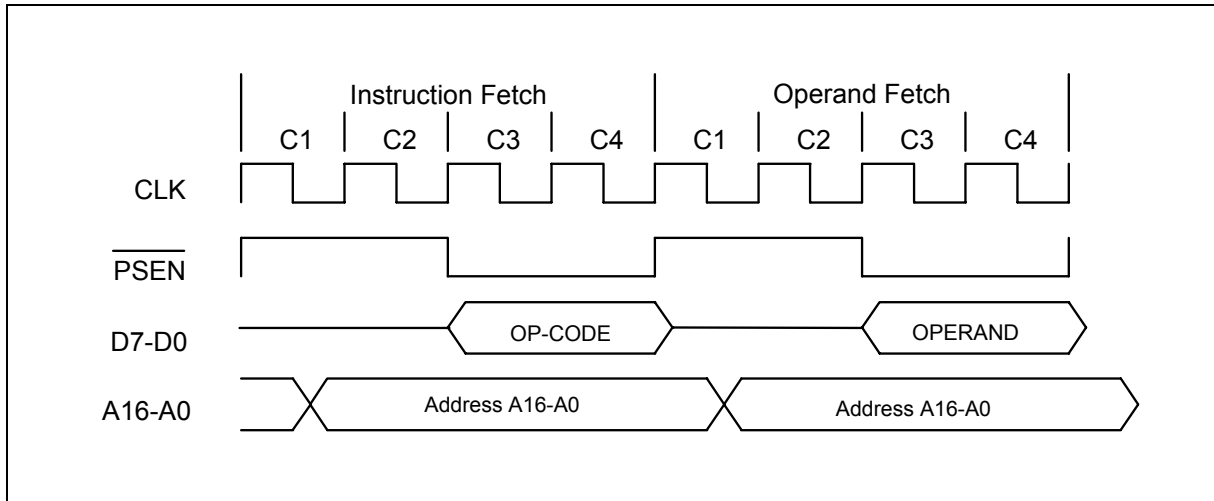

Data Read Cycle

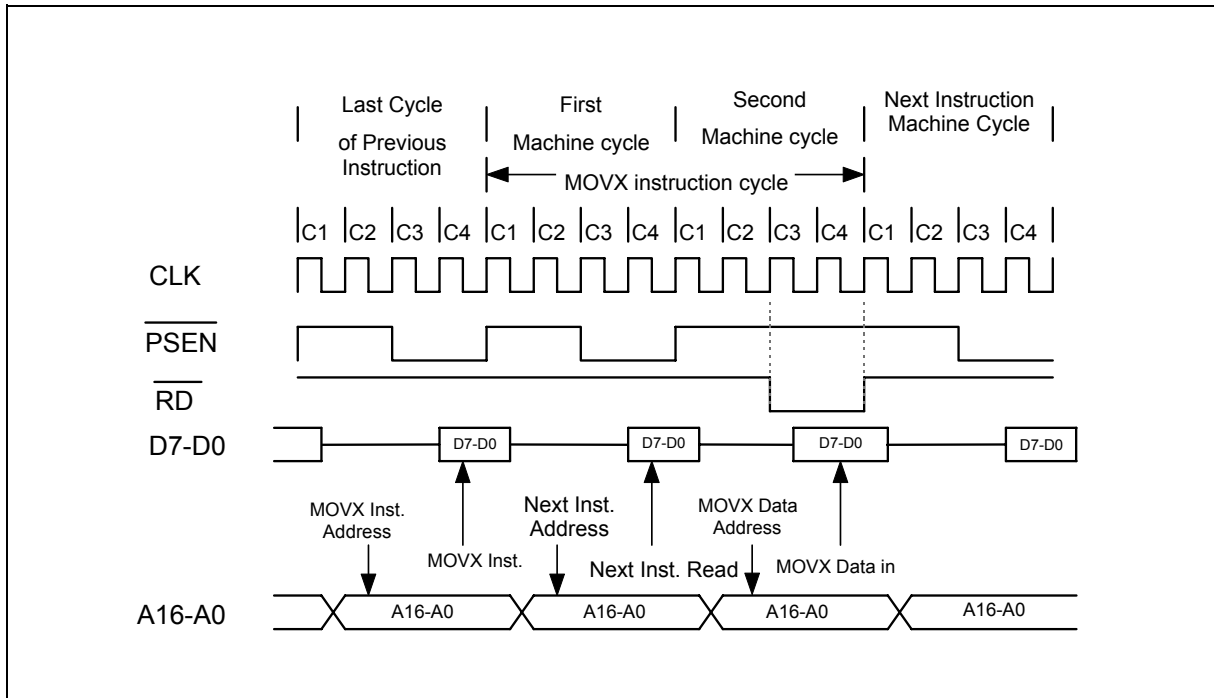



Timing Waveforms, continued

Data Write Cycle

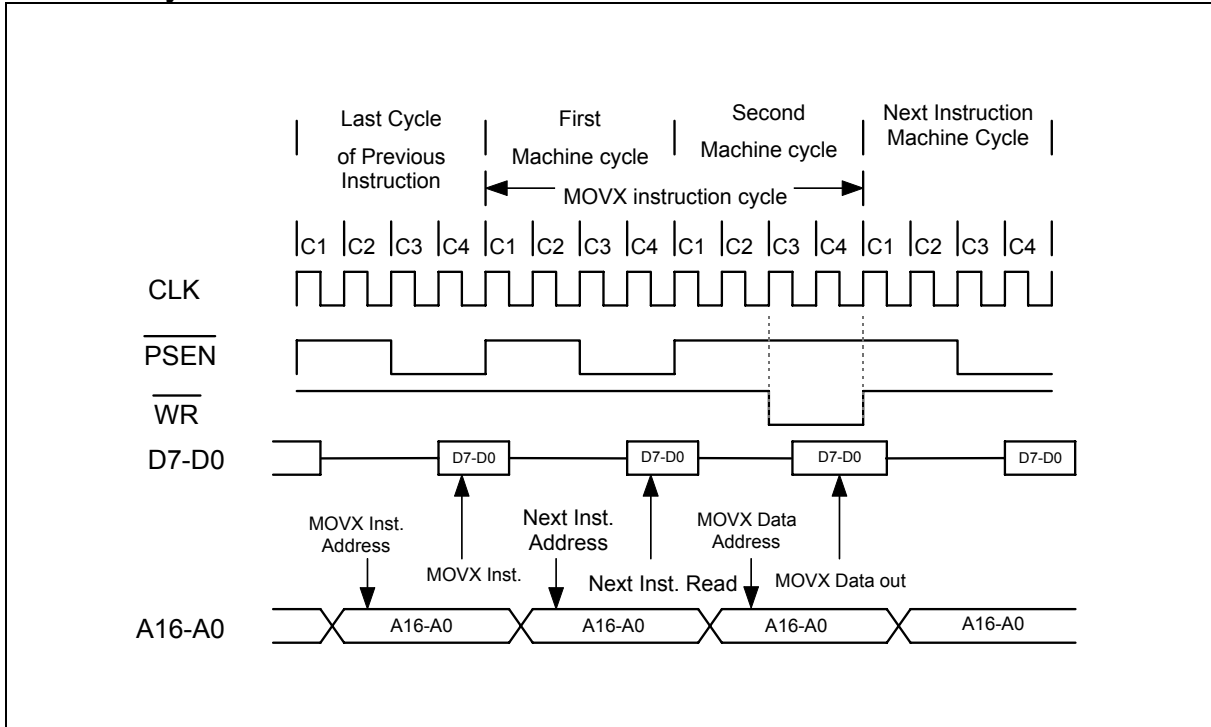

7.1 Instruction Timing

The instruction timing for the W925EP01 is an important aspect, especially for those users who wish to use software instructions to generate timing delays. Also, it provides the user with an insight into the timing differences between the W925EP01 and the standard 8032. In the W925EP01 each machine cycle is four clock periods long. Each clock period is designated a state. Thus each machine cycle is made up of four states, C1, C2 C3 and C4, in that order. Due to the reduced time for each instruction execution, both the clock edges are used for internal timing. Hence it is important that the duty cycle of the clock be as close to 50% as possible to avoid timing conflicts. As mentioned earlier, the W925EP01 does one op-code fetch per machine cycle. Therefore, in most of the instructions, the number of machine cycles needed to execute the instruction is equal to the number of bytes in the instruction. Of the 256 available op-codes, 128 of them are single cycle instructions. Thus more than half of all op-codes in the W925EP01 are executed in just four clock periods. Most of the two-cycle instructions are those that have two byte instruction codes. However there are some instructions that have only one byte instruction, yet they are two cycle instructions. One-instruction which is of importance is the MOVX instruction. In the standard 8032, the MOVX instruction is always two machine cycles long. However in the W925EP01, each machine cycle is made of only 4 clock periods compared to the 12 clock periods for the standard 8032. Therefore, even though the number of categories has increased, each instruction is at least 1.5 to 3 times faster than the standard 8032 in terms of clock periods.

W925EP01/ W925EP01FG

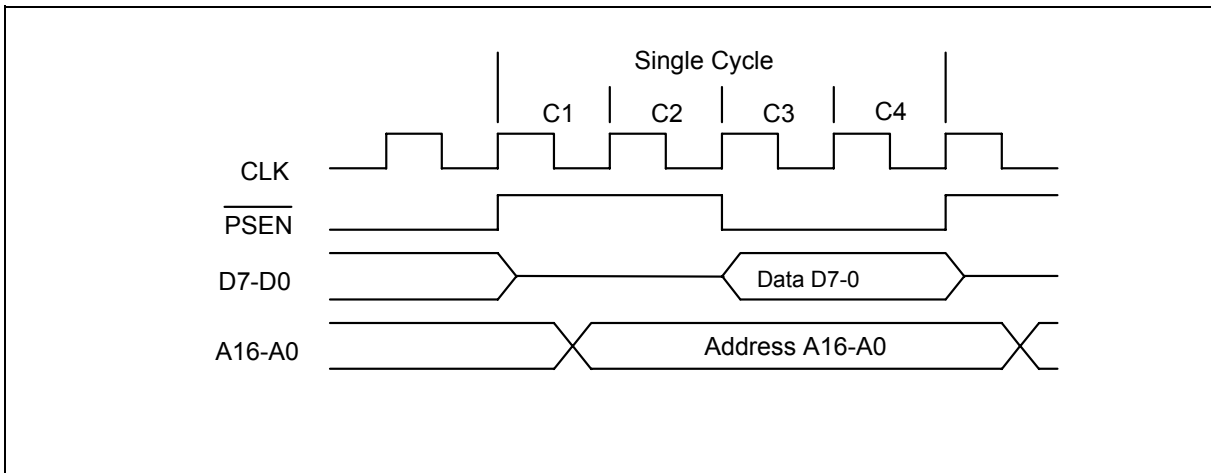

Single Cycle Instruction Timing

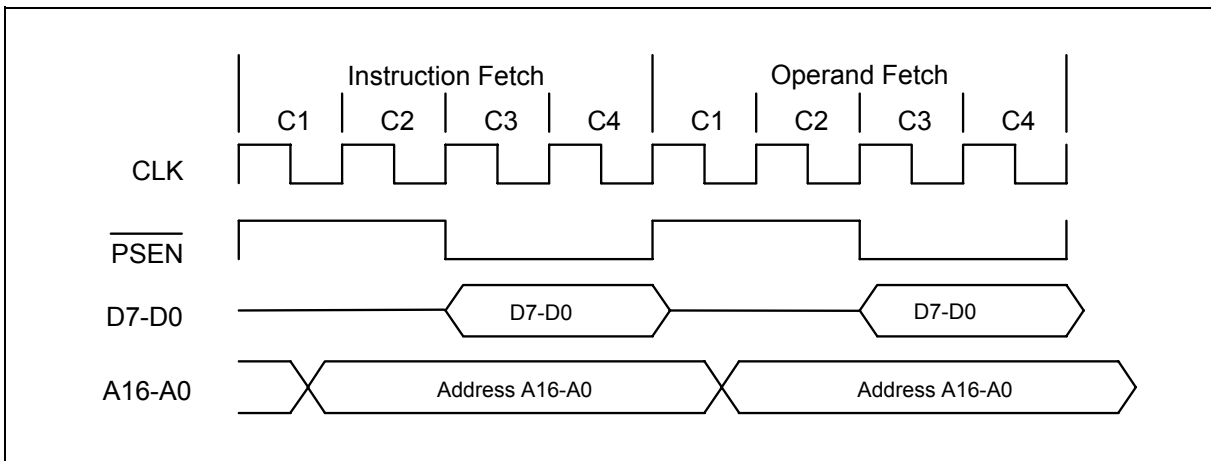

Two Cycle Instruction Timing

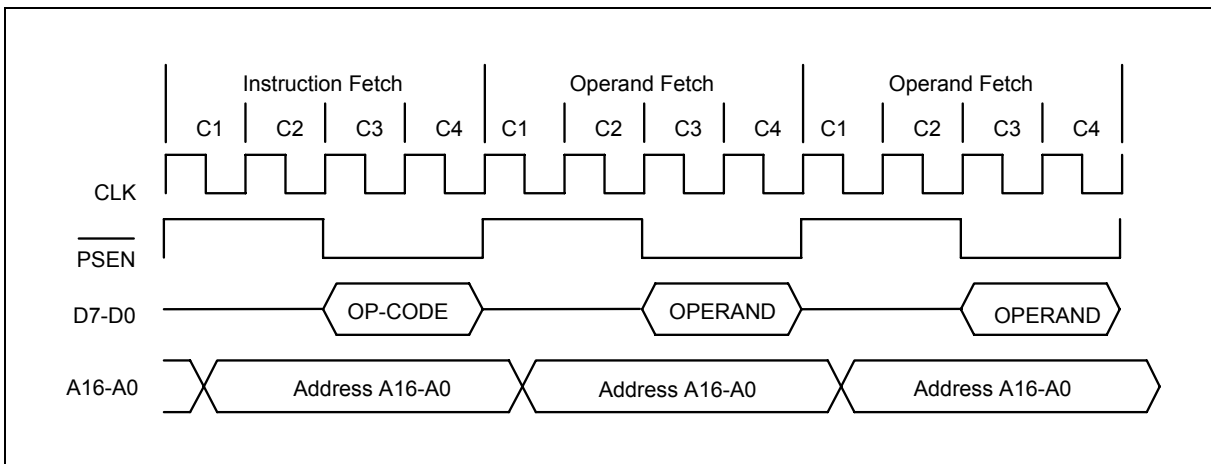

Three Cycle Instruction Timing

W925EP01/ W925EP01FG

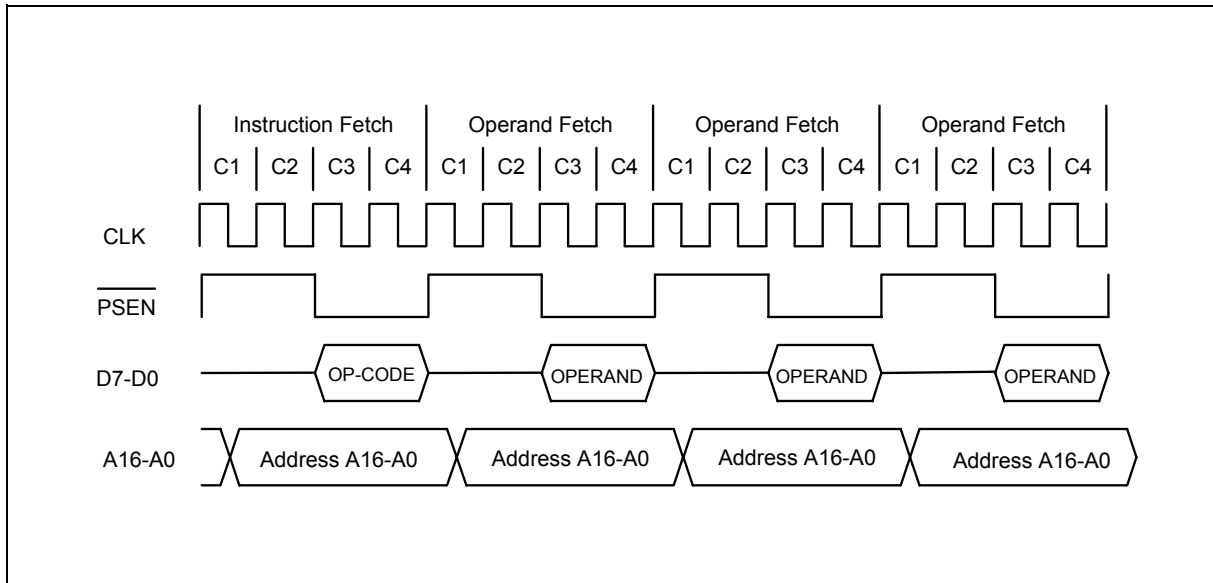

Four Cycle Instruction Timing

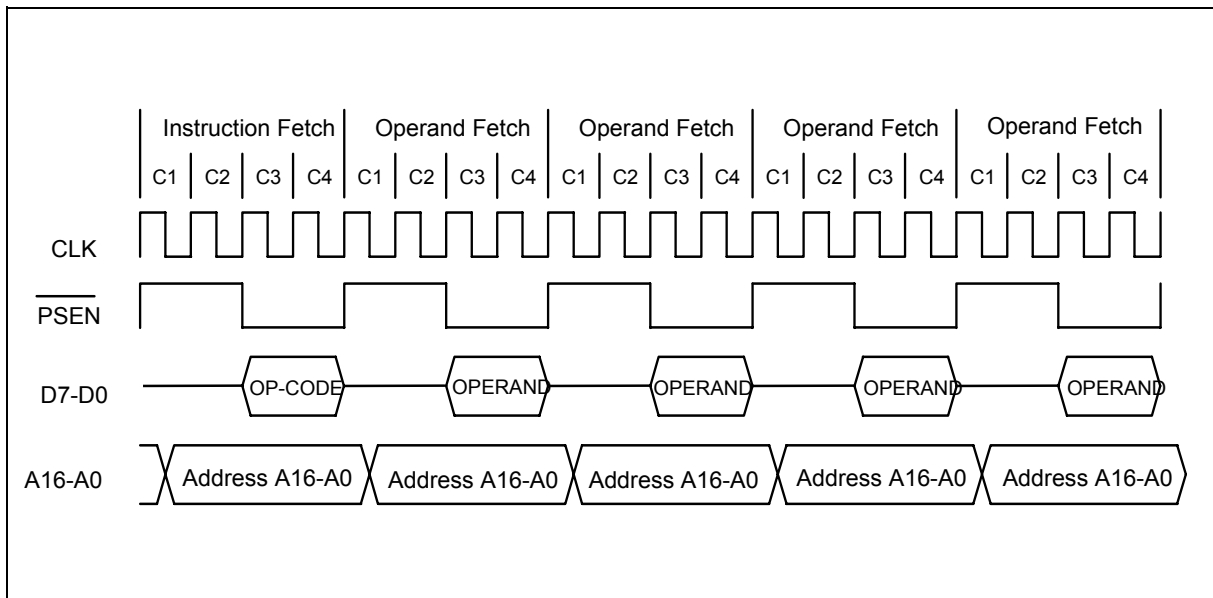

Five Cycle Instruction Timing



8. ELECTRICAL CHARACTERISTICS

8.1 Maximum Ratings*

(Voltage referenced to VSS pin)

	PARAMETER	SYMBOL	RATING	UNITS
1	Supply Voltage with respect to VSS	V_{DD}	-0.3 to 6	V
2	Voltage on any pin other than supplies (note 1)		-0.7 to $V_{DD} + 0.7$	V
3	Current at any pin other than supplies		0 to 10	mA
4	Storage Temperature	T_{st}	-65 to 150	°C

Note:

*. Exposure to conditions beyond those listed under Absolute Maximum Ratings may adversely affect the life and reliability of the device.

1. $V_{DD} + 0.7$ should not exceed maximum rating of supply voltage.

8.2 Recommended Operating Conditions

CHARACTERISTICS	SYMBOL	RATING	UNIT
Power Supplies (Analog)	V_{AD}	3.0 to 6.0	V
Power Supplies (Digital) Flash EPROM type	V_{DD}	2.4 to 5.5	V
THE ISP MODE OPERATES	V_{DD}	3.3 to 5.5	V
Main Clock Frequency	f_{OSC}	4/8	MHz
Sub Clock Frequency	f_{SUB}	32768	Hz
Tolerance on Clock Frequency	Δf_C	-0.1 to +0.1	%
Operation Temperature	T_{op}	0 to 75	°C



8.3 DC Electrical Characteristics

(VDD-VSS=3.0V, Fm=4MHz at non-specified note, Ta=25°C, all output unloaded & input fixed state)

PARAMETER	SYMBOL	CONDITION	MIN	TYP	MAX	UNIT	NOTE
Operating Current	I _{OP1}	FSK On, dual clock, normal run		2.8 4.8		mA	4M 8M
	I _{OP2}	FSK Off, dual clock, normal run		1.8 3.8		mA	4M 8M
	I _{OP3}	FSK off, slow run, main osc stopped		20 730		uA	4M 8M
	I _{OP4}	Idle mode, dual clock		1.0 2.0		mA	4M 8M
	I _{OP5}	Idle mode, main osc stopped		10		uA	4M 8M
	I _{OP6}	Power down mode				1	uA
I/O Ports Input High Voltage	V _{IH}		0.7V _{DD}		V _{DD}	V	
I/O Ports Input Low Voltage	V _{IL}		V _{SS}		0.3V _{DD}	V	
I/O Ports Output High Voltage	V _{OH}	I _{OH} = 2.0mA	2.4	-	-	V	
I/O Ports Output Low Voltage	V _{OL}	I _{OL} = 2.0mA	-	-	0.4	V	
BUZ Pin Output High Voltage	V _{BOH}	I _{OH} = 3.5mA	2.4	-	-	V	
BUZ Pin Output Low Voltage	V _{BOL}	I _{OL} = 3.5mA	0.4	-	-	V	
DTMF Output DC Level	V _{TDC}	R _L = 5KΩ, V _{DD} = 2.5-3.8	1.1	-	2.8	V	
DTMF Distortion	DTHD	R _L = 5KΩ, V _{DD} = 2.5-3.8	-	-30	-23	dB	
DTMF Output Voltage	V _{TO}	Low group, R _L = 5KΩ	130	150	170	mVrms	
Pre-emphasis		Col/Row	1	2	3	dB	
FSK Output DC Level	V _{FDC}	R _L = 5KΩ, V _{DD} = 2.5-3.8	1.1	-	2.8	V	

W925EP01/ W925EP01FG



DC Electrical Characteristics, continued

PARAMETER	SYMBOL	CONDITION	MIN	TYP	MAX	UNIT	NOTE
FSK Distortion	FTHD	$R_L = 5K\Omega, V_{DD} = 2.5-3.8$	-	-	-30	dB	
FSK Output Voltage	V_{FD}	$R_L = 5K\Omega$	75	150	170	mVrms	
Port Pull High Resistor	R_{PH}		100	450	1000	$K\Omega$	
RESET pin pull low Resistor	R_{PL}		100	170	250	$K\Omega$	
Schmitt Input High Threshold	V_{T+}	RNGDI, RNGRC	$0.48V_{AD}$	-	$0.68V_{AD}$	V	
Schmitt Input High Threshold	V_{T-}	RNGDI, RNGRC	$0.28V_{AD}$	-	$0.48V_{AD}$	V	
Schmitt Hysteresis	V_{HYS}	RNGDI, RNGRC		0.2		V	
RNGRC Low Sink Current	I_{RNGL}	RNGRC	2.5			mA	
Input Current	I_{IN}	INPx, INNx, RNGDI	-	-	1	μA	
Reference Output voltage	V_{REF}	VREF	$0.5V_{AD} - 4\%$	-	$0.5V_{AD} + 4\%$	V	No load
Reference Output Resistance	R_{REF}	VREF	-	-	2	$K\Omega$	



8.4 Electrical Characteristics - Gain Control OP-Amplifier

(Electrical characteristics supersede the recommended operating conditions unless otherwise stated.)

PARAMETER	SYMBOL	MIN	TYP [‡]	MAX	UNITS	TEST CONDITIONS
Input Leakage Current	I_{IN}			1	μA	$V_{SS} \leq V_{IN} \leq V_{DD}$
Input Resistance	R_{IN}	10			$M\Omega$	
Input Offset Voltage	V_{OS}			25	mV	
Power Supply Rejection Ratio	PSRR	40			dB	1 kHz 0.1 Vpp ripple on V_{DD}
Maximum Capacitive Load (GCFBx)	C_L			100	pF	
Maximum Resistive Load (GCFBx)	R_L	50			$k\Omega$	

Note: "‡" Typical figure are at $V_{DD} = 5V$ and temperature = 25 °C are design aids only, not guaranteed and not subject to production testing.

8.5 AC Electrical Characteristics

(AC timing characteristics supersede the recommended operating conditions unless otherwise stated.)

Dual Tone Alert Signal Detection Interface

PARAMETER	SYMBOL	MIN	TYP	MAX	UNITS	NOTES
Low Tone Frequency	f_L		2130		Hz	
High Tone Frequency	f_H		2750		Hz	
Frequency Deviation accept		1.1			%	3
Frequency Deviation reject		3.5			%	4
Maximum Input Signal Level				0.22	dBm^a	
Input Sensitivity per tone		-40	-38		dBm	5
Reject Signal Level per tone				-48	dBm	5
Positive and negative twist ^b accept		7			dB	
Noise Tolerance	SNR_{TONE}	20			dB	1, 2

Notes:

a. dBm = decibels with a reference power of 1 mW into 600 ohms, 0 dBm = 0.7746 Vrms.

b. Twist = $20 \log (f_H \text{ amplitude} / f_L \text{ amplitude})$.

- Both tones have the same amplitude. Both tones are at the nominal frequencies.
- Band limited random noise 300 - 3400 Hz. Present only when tone is present.
- Range within which tones are accepted.
- Ranges outside of which tones are rejected.
- These characteristics are at $V_{DD} = 5V$ and temperature = 25 °C.

W925EP01/ W925EP01FG



Dual Tone Alert Signal Detection

PARAMETER	CONDITION	SYMBOL	MIN	TYP [‡]	MAX	UNITS	NOTES
Alert Signal present detect time	ALGR	t_{DP}	0.5		10	MS	
Alert Signal absent detect time		t_{DA}	0.1		8	MS	

"[‡]" Typical figure are at $V_{DD} = 5V$ and temperature = 25 °C are design aids only, not guaranteed and not subject to production testing.

FSK Detection Interface

PARAMETER	SYMBOL	MIN	TYP	MAX	UNITS	NOTES
Input Frequency Detection						
Bell 202 Mark (logic 1)	f_{Mark}	1188	1200	1212	Hz	+/- 1 %
Bell 202 Space (logic 0)	f_{Space}	2178	2200	2222		+/- 1 %
ITU-T V.23 Mark (logic 1)	f_{Mark}	1280.5	1300	1319.5		+/- 1.5 %
ITU-T V.23 Space (logic 0)	f_{Space}	2068.5	2100	2131.5		+/- 1.5 %
Maximum Input Signal Level				-5.78	dBm	
Input Sensitivity		-43			dBm	1, 3
Transmission Rate		1188	1200	1212	baud	
Input Noise Tolerance	SNR _{TONE}	20			dB	1, 2

Notes:

- Both mark and space have the same amplitude. Both mark and space are at the nominal frequencies.
- Band limited random noise 300 - 3400 Hz. Present only when FSK signal is present.
- These characteristics are at $V_{DD} = 5V$ and temperature = 25 °C.

FSK Detection

PARAMETER	CONDITION	SYMBOL	MIN	TYP [‡]	MAX	UNITS	NOTES
FSK detection enable time	FSKE	t_{FSK}			25	MS	
Input FSK to FCD high delay	FCD	t_{CP}			25	MS	
Input FSK to FCD low delay		t_{CA}	8			MS	
Data Ready ACK Time	FDR	t_{DR}	415	416	417	US	2
Rate	DATA		1188	1200	1212	BpS	1
Input FSK to DATA delay		t_{IDD}		1	5	MS	
Frequency	DCLK	f_{DCLK}	1201.6	1202.8	1204	Hz	2
High Time		t_{CH}	415	416	417	US	2
Low Time		t_{CL}	415	416	417	US	2
DCLK to FDR delay	DCLK, FDR	t_{CRD}	415	416	417	US	2

W925EP01/ W925EP01FG



Note :

1. FSK input data rate at 1200 +/- 12 baud.
2. OSCI frequency at 4 MHz +/- 0.1%.

"‡" Typical figure are at V_{DD} = 5V and temperature = 25 °C are design aids only, not guaranteed and not subject to production testing.

DTMF Decoder

PARAMETER	SYMBOL	MIN	TYP	MAX	UNITS	NOTES
INPUT SENSITIVITY PER TONE		-29		1	dBm	1,2
Positive and negative twist accept		7			dB	1,2
Frequency Deviation accept		1.5			%	1,2
Frequency Deviation reject		3.5			%	1,2
3rd Tone Tolerance				-16	dB	1,2,3
Noise Tolerance				-12	dB	1,2,3
Dial tone Tolerance			22		dB	1,2,4

Note :

1. signal consists of all DTMF tones.
2. Tone duration is 40mS at least, tone pause duration is 40mS at least.
3. Referenced to the lowest level frequency component in DTMF signal.
4. Referenced to the minimum valid accept level.

DTMF Detection Interface

PARAMETER	CONDITION	SYMBOL	MIN	TYP‡	MAX	UNITS	NOTES
DTMF present detect time	Est	t _{FP}	0.5		8	MS	
DTMF absent detect time		t _{FA}	0.1		8	MS	
DTMF Detected Duration	DTMFD=1	t _{DD}	40			MS	
DTMF Signal Ignore Time	DTMFD=0	t _{DI}			20	MS	
DTMF Pause Accept Time	DTMFD=1	t _{DPA}	20			MS	

"‡" Typical figure are at V_{DD} = 5V and temperature = 25 °C are design aids only, not guaranteed and not subject to production testing.

W925EP01/ W925EP01FG



9. PACKAGE

100L QFP(14x20x2.75mm footprint 4.8mm)

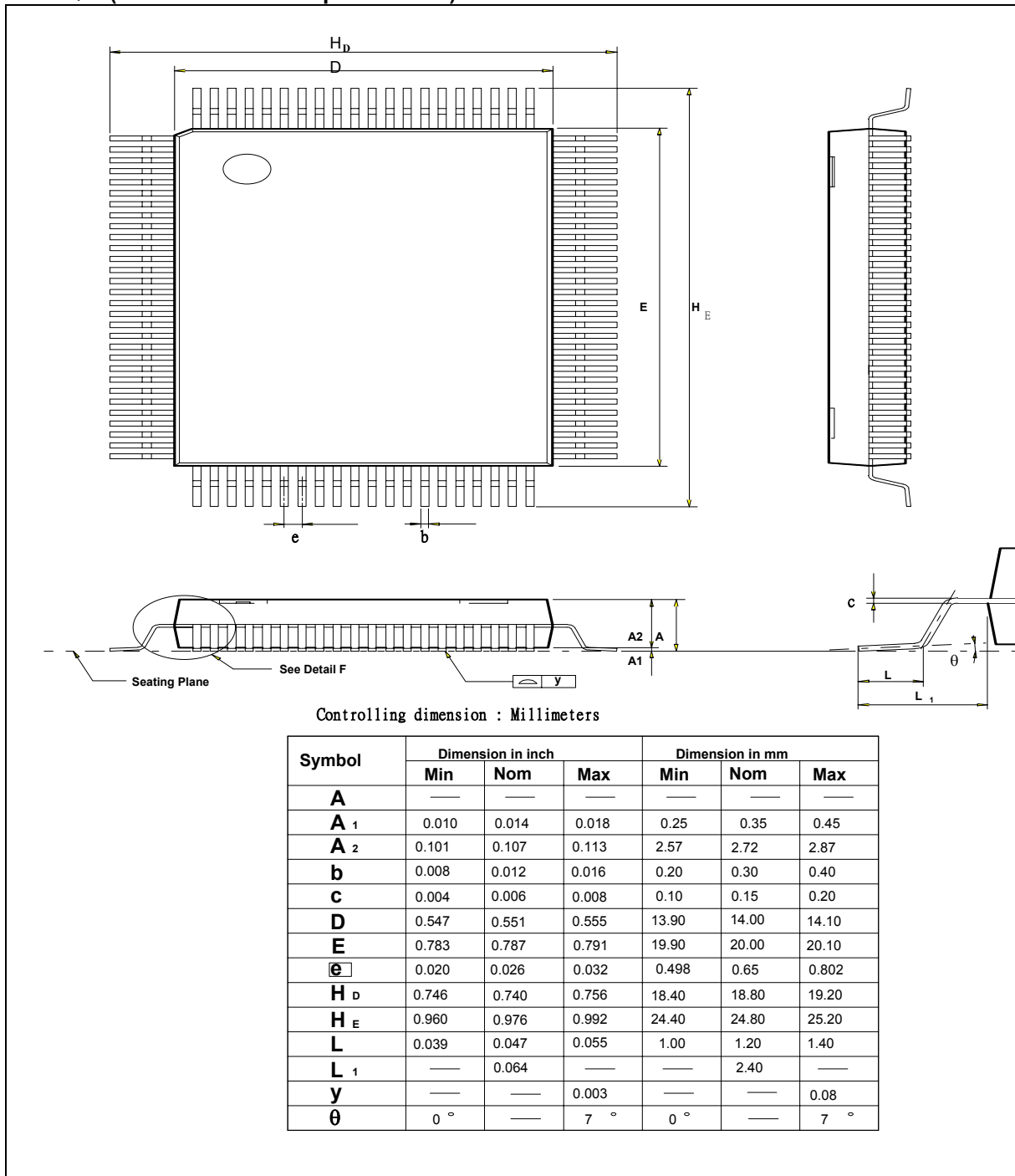



10. REVISION HISTORY

VERSION	DATE	PAGE	DESCRIPTION
A1	Dec. 6, 2005		New Create
A2	Apr. 10, 2006	3	Modify lead-free package number

Important Notice

Winbond products are not designed, intended, authorized or warranted for use as components in systems or equipment intended for surgical implantation, atomic energy control instruments, airplane or spaceship instruments, transportation instruments, traffic signal instruments, combustion control instruments, or for other applications intended to support or sustain life. Further more, Winbond products are not intended for applications wherein failure of Winbond products could result or lead to a situation wherein personal injury, death or severe property or environmental damage could occur.

Winbond customers using or selling these products for use in such applications do so at their own risk and agree to fully indemnify Winbond for any damages resulting from such improper use or sales.



Headquarters
No. 4, Creation Rd. III,
Science-Based Industrial Park,
Hsinchu, Taiwan
TEL: 886-3-5770066
FAX: 886-3-5665577
<http://www.winbond.com.tw/>

Taipei Office
9F, No.480, Rueiguang Rd.,
Neihu District, Taipei, 114,
Taiwan, R.O.C.
TEL: 886-2-8177-7168
FAX: 886-2-8751-3579

Winbond Electronics Corporation America
2727 North First Street, San Jose,
CA 95134, U.S.A.
TEL: 1-408-9436666
FAX: 1-408-5441798

Winbond Electronics Corporation Japan
7F Daini-ueno BLDG, 3-7-18
Shinyokohama Kohoku-ku,
Yokohama, 222-0033
TEL: 81-45-4781881
FAX: 81-45-4781800

Winbond Electronics (Shanghai) Ltd.
27F, 2299 Yan An W. Rd. Shanghai,
200336 China
TEL: 86-21-62365999
FAX: 86-21-62365998

Winbond Electronics (H.K.) Ltd.
Unit 9-15, 22F, Millennium City,
No. 378 Kwun Tong Rd.,
Kowloon, Hong Kong
TEL: 852-27513100
FAX: 852-27552064

*Please note that all data and specifications are subject to change without notice.
All the trade marks of products and companies mentioned in this data sheet belong to their respective owners.*