

## Stellaris<sup>®</sup> LM3S5P36 RevB1 Errata

This document contains known errata at the time of publication for the Stellaris<sup>®</sup> LM3S5P36 microcontroller. The table below summarizes the errata and lists the affected revisions. See the data sheet for more details.

See also the ARM<sup>®</sup> Cortex<sup>™</sup>-M3 errata, ARM publication number PR326-PRDC-009450 v2.0.

Erratum Number	Erratum Title	Revision(s) Affected
1.1	JTAG INTEST instruction does not work	B1
1.2	The Recover Locked Device sequence does not work	B1
2.1	Hard Fault possible when waking from Sleep or Deep-Sleep modes and Cortex-M3 Debug Access Port (DAP) is enabled	B1
2.2	Sleep and Deep-Sleep mode not usable at higher speeds when ISRs reside in Flash memory	B1
2.3	Device Capabilities registers may not accurately reflect available signals	B1
2.4	The PIOSC is not trimmed by the factory	B1
2.5	The CLASS field in Device Identification 0 (DID0) register is incorrect	B1
3.1	Hibernation module may have higher current draw than specified in data sheet under certain conditions	B1
3.2	Hibernate POR may not reset the Hibernation module until $V_{DD}$ is applied	B1
3.3	Power consumption increases if $V_{DD}$ is not restored after wake from hibernation	B1
3.4	ESD protection on the $V_{BAT}$ pin does not meet specifications	B1
3.5	Use of the VDD3ON mode to initiate hibernation damages the part	B1
3.6	Hibernate module power consumption higher than expected in event wakeup configuration	B1
3.7	The Real-Time Clock gains or loses time going in and out of hibernation when using a crystal	B1
3.8	Low-battery detect circuit is powered down during hibernate	B1
4.1	Cumulative page erases may introduce bit errors in Flash memory	B1
4.2	Flash Write Buffer does not function above 50 MHz	B1
5.1	Some ROM functions are unsupported	B1
5.2	ROM mapping check for the Boot loader does not function properly	B1
6.1	Port B [1:0] pins require external pull-up resistors	B1
7.1	UART Smart Card (ISO 7816) mode does not function	B1
7.2	When in IrDA mode, the UnRx signal requires configuration even if not used	B1
8.1	An interrupt is not generated when using $\mu$ DMA with the SSI module if the EOT bit is set	B1

Erratum Number	Erratum Title	Revision(s) Affected
9.1	USB0ID and USB0VBUS signals are required to be connected regardless of mode	B1
9.2	Latch up may occur if power is applied to the VBUS pin but not to VDD	B1
10.1	PWM generation is incorrect with extreme duty cycles	B1
10.2	Sync of PWM does not trigger "zero" action	B1
10.3	PWM "zero" action occurs when the PWM module is disabled	B1
10.4	PWM Enable Update register bits do not function	B1
11.1	Power-on event may disrupt operation	B1
11.2	Momentarily exceeding $V_{IN}$ ratings on any pin can cause latch-up	B1

# 1 JTAG

## 1.1 JTAG INTEST instruction does not work

### Description:

The JTAG INTEST (Boundary Scan) instruction does not properly capture data.

### Workaround:

None.

### Silicon Revision Affected:

B1

### Fixed:

Fixed in Rev C.

## 1.2 The Recover Locked Device sequence does not work

### Description:

If software configures any of the JTAG/SWD pins as GPIO or loses the ability to communicate with the debugger, there is a debug sequence that can be used to recover the microcontroller, called the Recover Locked Device sequence. After reconfiguring the JTAG/SWD pins, using the Recover Locked Device sequence does not recover the device.

### Workaround:

To get the device unlocked, follow these steps:

1. Power cycle the board and run the debug port unlock procedure in LM Flash Programmer. DO NOT power cycle when LM Flash Programmer tells you to.
2. Go to the Flash Utilities tab in LM Flash Programmer and do a mass erase operation (check "Entire Flash" and then click the Erase button). This erase appears to have failed, but that is ok.
3. Power cycle the board.

4. Go to the Flash Utilities tab in LM Flash Programmer and do another mass erase operation (check "Entire Flash" and then click the Erase button).

**Silicon Revision Affected:**

B1

**Fixed:**

Not fixed in Rev C.

## 2 System Control

### 2.1 Hard Fault possible when waking from Sleep or Deep-Sleep modes and Cortex-M3 Debug Access Port (DAP) is enabled

**Description:**

If the Cortex-M3 Debug Access Port (DAP) has been enabled, and the device wakes from a low power sleep or deep-sleep mode, the core may start executing code before all clocks to peripherals have been restored to their run mode configuration. The DAP is usually enabled by software tools accessing the JTAG or SWD interface when debugging or flash programming. If this condition occurs, a Hard Fault is triggered when software accesses a peripheral with an invalid clock.

**Workaround:**

A software delay loop can be used at the beginning of the interrupt routine that is used to wake up a system from a WFI (Wait For Interrupt) instruction. This stalls the execution of any code that accesses a peripheral register that might cause a fault. This loop can be removed for production software since the DAP is most likely not enabled during normal execution.

Since the DAP is disabled by default (power on reset), the user can also power cycle the device. The DAP will not be enabled unless it is enabled through the JTAG or SWD interface.

**Silicon Revision Affected:**

B1

**Fixed:**

Will not be fixed.

### 2.2 Sleep and Deep-Sleep mode not usable at higher speeds when ISRs reside in Flash memory

**Description:**

Sleep and Deep-Sleep modes cannot be used when running the processor at 66 or 80 MHz when the ISRs and vector table reside in Flash memory. If Sleep or Deep-Sleep mode is used at those speeds, an invalid PC is sometimes returned for the interrupt vector address when exiting sleep mode.

**Workaround:**

There are two possible workarounds for this issue:

1. Store the ISRs and vector table in the on-chip SRAM when running the processor at 66 or 80 MHz.

2. Run the processor at 50 MHz.

**Silicon Revision Affected:**

B1

**Fixed:**

Fixed in Rev C.

## 2.3 Device Capabilities registers may not accurately reflect available signals

**Description:**

Some of the Device Capabilities register bits reflect the presence of specific pins on the microcontroller. These bits do not always properly reflect the available signals. Bits affected include **DC3** [31:0], **DC4** [15:14], **DC5** [27:24] and [7:0], and **DC8** [31:0]. Do not rely on the value of these bits in system design.

**Workaround:**

None.

**Silicon Revision Affected:**

B1

**Fixed:**

Fixed in Rev C.

## 2.4 The PIOSC is not trimmed by the factory

**Description:**

The PIOSC is not trimmed by the factory prior to shipment.

**Workaround:**

For parts that have a Hibernation module, the PIOSC can be user calibrated.

**Silicon Revision Affected:**

B1

**Fixed:**

Fixed in Rev C.

## 2.5 The CLASS field in Device Identification 0 (DID0) register is incorrect

**Description:**

The **CLASS** field, bits[23:16], in the **Device Identification 0 (DID0)** register is incorrect. The **CLASS** field should be 0x04 indicating the Stellaris Tempest class of microcontrollers. Instead, the field reads as 0x03.

**Workaround:**

None.

**Silicon Revision Affected:**

B1

**Fixed:**

Not fixed in Rev C.

## 3 Hibernation Module

### 3.1 Hibernation module may have higher current draw than specified in data sheet under certain conditions

**Description:**

If a battery voltage is applied to the  $V_{BAT}$  power pin prior to power being applied to the  $V_{DD}$  power pins of the device, the current draw from the  $V_{BAT}$  pin is greater than expected. The current may be as high as 1.6 mA instead of the data sheet specified 17  $\mu$ A. The condition exists until power is applied to the  $V_{DD}$  pin. Once the  $V_{DD}$  pin has been powered, the  $V_{BAT}$  current draw functions as expected. The  $V_{DD}$  pin can then be powered up and down as required and the  $V_{BAT}$  pin current specification is maintained.

**Workaround:**

The  $V_{BAT}$  pin higher-than-specified current draw condition can be avoided if the microcontroller's  $V_{DD}$  power pins are powered on prior to the time a battery voltage is initially applied to the  $V_{BAT}$  pin.

**Silicon Revision Affected:**

B1

**Fixed:**

Fixed in Rev C.

### 3.2 Hibernate POR may not reset the Hibernation module until $V_{DD}$ is applied

**Description:**

If  $V_{DD}$  is not powered when voltage is first applied to  $V_{BAT}$ , the state of the Hibernation module is indeterminate and the  $\overline{HIB}$  signal may be asserted. In this indeterminate state, a lock condition can occur in which the Hibernation module waits for a power-on-reset, but that reset cannot occur until the module deasserts  $\overline{HIB}$ . This issue is related to the errata "Hibernation module may have higher current draw than specified in data sheet under certain conditions" on page 5.

**Workaround:**

The workaround implementation depends on the system-level power supply configuration. For systems that use a battery as the primary power source, an external voltage supervisor (TPS383J25DBV or similar) circuit can be added to force the  $V_{DD}$  power supply to start when the battery voltage is first applied (see Figure 1). The voltage supervisor requires only 220 nA and



**Silicon Revision Affected:**

B1

**Fixed:**

Fixed in Rev C.

### 3.4 ESD protection on the V<sub>BAT</sub> pin does not meet specifications

**Description:**

The ESD protection on the V<sub>BAT</sub> pin fails when tested at 2 kV.

**Workaround:**

Extra precaution should be taken to protect the part from ESD events. Some applications may require system-level ESD protection on this pin.

**Silicon Revision Affected:**

B1

**Fixed:**

Fixed in Rev C.

### 3.5 Use of the VDD3ON mode to initiate hibernation damages the part

**Description:**

The VDD3ON mode is enabled by setting the VDD3ON bit in the **Hibernation Control (HIBCTL)** register. Permanent damage can occur to the device if this mode is used.

**Workaround:**

Do not use the VDD3ON mode to enter hibernation, instead use an external switch or regulator to manage V<sub>DD</sub> power to the device.

**Silicon Revision Affected:**

B1

**Fixed:**

Fixed in Rev C.

### 3.6 Hibernate module power consumption higher than expected in event wakeup configuration

**Description:**

With the Hibernation module configured for an external event wakeup, the current consumption of the device is higher than expected. The Hibernation module clock does not shut down properly during the hibernate asynchronous external wake mode resulting in extra current consumption. Some devices properly shut down the clock the first time entering this mode and others do not. When waking from a hibernate event, the Hibernation module clock is always enabled. In subsequent hibernate cycles, the oscillator is not shut down properly and remains active. Hibernate module current consumption averages 21µA with the clock disabled. The current consumption averages 31µA with the Hibernation module clock enabled.

**Workaround:**

When the Hibernation module clock is not required during hibernation, software can disable it by clearing the `CLK32EN` bit in the **Hibernation Control (HIBCTL)** register before going into hibernation mode.

**Silicon Revision Affected:**

B1

**Fixed:**

Fixed in Rev C.

### 3.7 The Real-Time Clock gains or loses time going in and out of hibernation when using a crystal

**Description:**

When using a 4.194304-MHz crystal, the Real-Time clock in the Hibernation module gains or loses a small amount of time (on the order of one second over a 24-hour period when cycling hibernate mode 4 times a minute) when going in and out of hibernation.

**Workaround:**

Use an external 32.768-kHz oscillator as the source for the Hibernation module clock.

**Silicon Revision Affected:**

B1

**Fixed:**

Fixed in Rev C.

### 3.8 Low-battery detect circuit is powered down during hibernate

**Description:**

The low-battery detect feature on the  $V_{BAT}$  input is only valid when  $V_{DD}$  power is present. As a result:

- Because the battery is not electrically loaded when  $V_{DD}$  is present, the low-battery detect circuit may not reflect the actual battery status.
- In Hibernate mode, a low-battery condition may prevent wake until the battery is completely depleted.

**Workaround:**

None.

**Silicon Revision Affected:**

B1

**Fixed:**

Fixed in Rev C.



## 4 Internal Memory

### 4.1 Cumulative page erases may introduce bit errors in Flash memory

**Description:**

Cumulative page erases anywhere in the Flash memory array may introduce bit errors. The bit error is not confined to the page being erased or the 4-KB block but could be in any page in the Flash memory. A page erase is used to erase a 1-KB page so it can be rewritten. A mass erase erases the entire Flash memory array (all pages). A bit error means that a bit may change from 0 to 1 or 1 to 0.

**Workaround:**

There are two possible workarounds for this issue:

1. Minimize total page erases to less than 3000 between mass erases for the lifetime of the product. After each mass erase, an additional 3000 page erase operations are allowed before bit errors may be introduced. At the rate of one page erase per week, this issue would not be seen over at least 17 years.
2. Perform CRC checks on all Flash memory after page erases to increase the chances of detecting the issue. The two CRC functions built into ROM can assist in this.

**Silicon Revision Affected:**

B1

**Fixed:**

Fixed in Rev C.

### 4.2 Flash Write Buffer does not function above 50 MHz

**Description:**

The Flash Write Buffer does not successfully program the Flash memory at speeds above 50 MHz.

**Workaround:**

Lower the speed of the system clock to 50 MHz or less while programming the Flash memory.

**Silicon Revision Affected:**

B1

**Fixed:**

Fixed in Rev C.

## 5 ROM

### 5.1 Some ROM functions are unsupported

**Description:**

The following functions are unsupported in ROM:

- CANBitRateSet
- GPIOPinConfigure
- GPIOPinTypeI2S
- I2CSlaveIntClearEx
- I2CSlaveIntDisableEx
- I2CSlaveIntEnableEx
- I2CSlaveIntStatusEx
- I2SRxDisable
- SysCtlDelay
- UARTBusy
- UARTFIFODisable
- UARTFIFOEnable
- UARTRxErrorClear
- UARTRxErrorGet
- UARTRxIntModeGet
- UARTRxIntModeSet
- uDMAChannelSelectDefault
- uDMAChannelSelectSecondary
- USBDevEndpointConfigGet
- USBEndpointDataAvail
- USBEndpointDMAChannel
- USBEndpointDMADisable
- USBEndpointDMAEnable
- USBModeGet
- USBOTGHostRequest

**Workaround:**

Code for these functions is included in the current version of StellarisWare, which can be downloaded from the website at [http://www.luminarymicro.com/products/software\\_updates.html](http://www.luminarymicro.com/products/software_updates.html).

**Silicon Revision Affected:**

B1

**Fixed:**

Fixed in Rev C.

## 5.2 ROM mapping check for the Boot loader does not function properly

**Description:**

Before the processor is released from the reset state, the System Control module is supposed to check offset 0x0000.0004 of Flash memory looking for a reset vector that is not 0xFFFF.FFFF. If an initialized reset vector is found, Flash memory is mapped to address 0x0000.0000, otherwise ROM is mapped to address 0x0000.0000. Currently, the System Control module errantly checks offset 0x0000.0008, which is the NMI vector. So, in situations where a valid reset vector (offset 0x0000.0004) has been programmed, but the NMI vector has not been programmed, the ROM is errantly mapped to zero preventing the application that is stored in Flash memory from being executed out of reset.

**Workaround:**

Ensure that the NMI vector is always programmed.

**Silicon Revision Affected:**

B1

**Fixed:**

Not fixed in Rev C.

## 6 GPIO

### 6.1 Port B [1:0] pins require external pull-up resistors

**Description:**

The internal pull-up resistors are not effective for the Port B0 and B1 pins.

**Workaround:**

External pull-up resistors must be used on these two pins.

**Silicon Revision Affected:**

B1

**Fixed:**

Fixed in Rev C.

## 7 UART

### 7.1 UART Smart Card (ISO 7816) mode does not function

**Description:**

The  $U_nTX$  signal does not function correctly as the bit clock in Smart Card mode.

**Workaround:**

None.

**Silicon Revision Affected:**

B1

**Fixed:**

Fixed in Rev C.

### 7.2 When in IrDA mode, the UnRx signal requires configuration even if not used

**Description:**

When in IrDA mode, the transmitter may not function correctly if the  $U_nRx$  signal is not used.

**Workaround:**

When in IrDA mode, if the application does not require the use of the `UnRx` signal, the GPIO pin that has the `UnRx` signal as an alternate function must be configured as the `UnRx` signal and pulled High.

**Silicon Revision Affected:**

B1

**Fixed:**

Fixed in Rev C.

## 8 SSI

### 8.1 An interrupt is not generated when using $\mu$ DMA with the SSI module if the EOT bit is set

**Description:**

When using the primary  $\mu$ DMA channels with the SSI module, an interrupt is not generated on transmit  $\mu$ DMA completion if the `EOT` bit (bit 4 of the **SSICR1** register) is enabled.

**Workaround:**

Use the alternate  $\mu$ DMA channels for the SSI module.

**Silicon Revision Affected:**

B1

**Fixed:**

Fixed in Rev C.

## 9 USB

### 9.1 USB0ID and USB0VBUS signals are required to be connected regardless of mode

**Description:**

The `DEVMODOTG` bit in the **USB General-Purpose Control and Status (USBGPCS)** register does not function correctly.

**Workaround:**

Connect the `USB0VBUS` input to `VBUS` in all modes. In addition, connect the `USB0ID` pin to ground for Host mode operation and to `VDD` for Device mode operation using the `DEVMOD` bit in the **USB General-Purpose Control and Status (USBGPCS)** register.

**Silicon Revision Affected:**

B1

**Fixed:**

Fixed in Rev C.

## 9.2 Latch up may occur if power is applied to the VBUS pin but not to VDD

**Description:**

If power is applied to the VBUS pin but not to VDD, the microcontroller may latch up and or draw excessive current. This condition can occur if the microcontroller is unpowered and is connected as a USB device or OTG B.

**Workaround:**

Power up the microcontroller before attaching the USB cable. Also, the USB cable must be detached before powering down the microcontroller.

**Silicon Revision Affected:**

B1

**Fixed:**

Fixed in Rev C.

## 10 PWM

### 10.1 PWM generation is incorrect with extreme duty cycles

**Description:**

If a PWM generator is configured for Count-Up/Down mode, and the **PWM Load (PWMnLOAD)** register is set to a value N, setting the compare to a value of 1 or N-1 results in steady state signals instead of a PWM signal. For example, if the user configures PWM0 as follows:

- PWMENABLE = 0x00000001
  - PWM0 Enabled
- PWM0CTL = 0x00000007
  - Debug mode enabled
  - Count-Up/Down mode
  - Generator enabled
- PWM0LOAD = 0x00000063
  - Load is 99 (decimal), so in Count-Up/Down mode the counter counts from zero to 99 and back down to zero (200 clocks per period)
- PWM0GENA = 0x000000b0
  - Output High when the counter matches comparator A while counting up
  - Output Low when the counter matches comparator A while counting down

- PWM0DBCTL = 0x00000000
  - Dead-band generator is disabled

If the **PWM0 Compare A (PWM0CMPA)** value is set to 0x00000062 (N-1), PWM0 should output a 2-clock-cycle long High pulse. Instead, the PWM0 output is a constant High value.

If the **PWM0CMPA** value is set to 0x00000001, PWM0 should output a 2-clock-cycle long negative (Low) pulse. Instead, the PWM0 output is a constant Low value.

**Workaround:**

User software must ensure that when using the PWM Count-Up/Down mode, the compare values must never be 1 or the **PWMnLOAD** value minus one (N-1).

**Silicon Revision Affected:**

B1

**Fixed:**

Fixed in Rev C.

## 10.2 Sync of PWM does not trigger "zero" action

**Description:**

If the **PWM Generator Control (PWM0GENA)** register has the `ActZero` field set to 0x2, then the output is set to 0 when the counter reaches 0, as expected. However, if the counter is cleared by setting the appropriate bit in the **PWM Time Base Sync (PWMSYNC)** register, then the "zero" action is not triggered, and the output is not set to 0.

**Workaround:**

None.

**Silicon Revision Affected:**

B1

**Fixed:**

Fixed in Rev C.

## 10.3 PWM "zero" action occurs when the PWM module is disabled

**Description:**

The zero pulse may be asserted when the PWM module is disabled.

**Workaround:**

None.

**Silicon Revision Affected:**

B1

**Fixed:**

Fixed in Rev C.

## 10.4 PWM Enable Update register bits do not function

### Description:

The  $ENUPDn$  bits in the **PWM Enable Update (PWMENUUPD)** register do not function. As a result, enabling the PWM modules can't be synchronized.

### Workaround:

None.

### Silicon Revision Affected:

B1

### Fixed:

Fixed in Rev C.

## 11 Electrical Characteristics

### 11.1 Power-on event may disrupt operation

#### Description:

Incorrect power sequencing during power up can disrupt operation and potentially cause device failure.

#### Workaround:

$V_{DDC}$  must be applied approximately 50  $\mu$ s before  $V_{DD}$ . Normally  $V_{DDC}$  is controlled by the part's internal LDO voltage regulator. The workaround requires the addition of an external regulator (see Figure 2) to ensure that  $V_{DDC}$  sequencing requirements are met (see Figure 3). Recommended regulators include FAN1112SX (SOT223) and FAN2558S12X (SOT23-5).

This fix mitigates the on-chip power issue, but does not solve it completely. During development, the Flash memory should also be reprogrammed (using LMflash or another programming tool) at least once a week.

**Figure 2. Configuration of External Regulator**

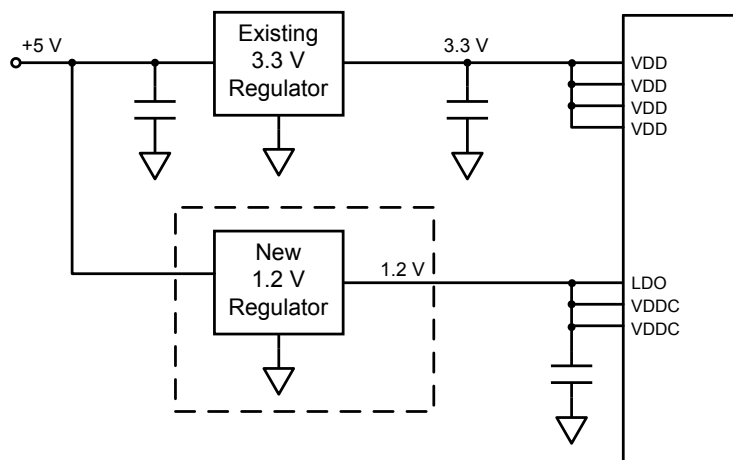
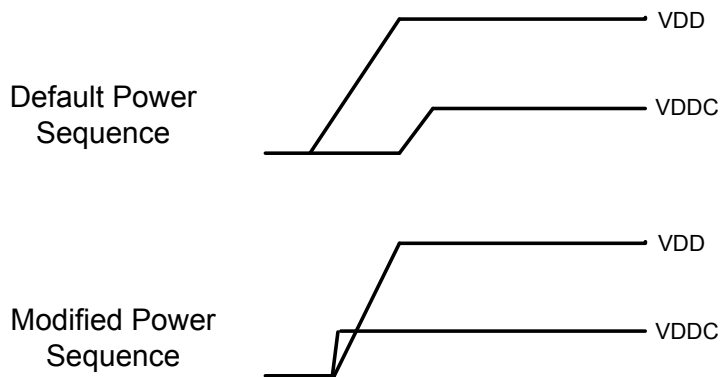


Figure 3. VDDC Sequencing Requirements



Detailed characterization is ongoing. Contact the Applications Support Team for the latest information.

**Silicon Revision Affected:**

B1

**Fixed:**

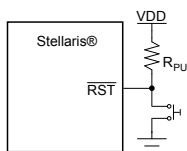
Fixed in Rev C.

## 11.2 Momentarily exceeding $V_{IN}$ ratings on any pin can cause latch-up

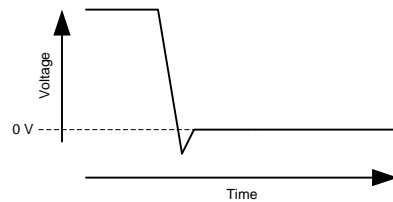
**Description:**

To avoid latch-up, the maximum DC ratings of the part must be strictly enforced. The most common violation of the  $V_{IN}$  electrical specification can occur when a mechanical switch or contact is connected directly to a GPIO or special function ( $\overline{RST}$ ,  $\overline{WAKE}$ , ...) pin. The circuit shown in Figure 4 on page 16 typically has stray inductance and capacitance that can cause a voltage glitch when the switch transitions, as shown in Figure 5 on page 17. The magnitude of the glitch may exceed the  $V_{IN}$  in the maximum DC ratings table in the Electrical Characteristics chapter. Figure 6 on page 17 shows an improved circuit that eliminates the glitch.

**Figure 4. Incorrect Reset Circuitry**

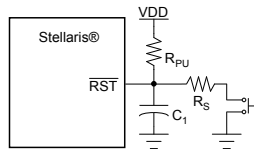




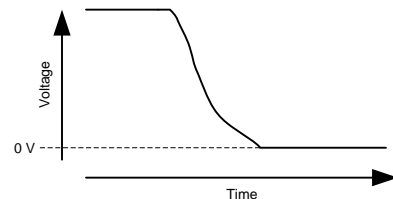
**Figure 5. Excessive Undershoot Voltage on Reset****Workaround:**

Use a circuit as shown in Figure 6 on page 17. In this circuit,  $R_S$  should be less than or equal to  $R_{PU}/10$ .  $C_1$  should be matched to  $R_{PU}$  to achieve a suitable  $t_{RC}$  for the application. Typical values are:

- $R_{PU} = 10 \text{ k}\Omega$
- $R_S = 470 \Omega$
- $C_1 = 0.01 \mu\text{F}$

**Figure 6. Recommended Reset Circuitry**

After implementing the circuit shown in Figure 6 on page 17, confirm that the voltage on the  $\overline{\text{RST}}$  input has a curve similar to the one in Figure 7 on page 17, and that the  $V_{IN}$  specification is not exceeded.

**Figure 7. Recommended Voltage on Reset****Silicon Revision Affected:**

B1

**Fixed:**

Fixed in Rev C.

---

Copyright © 2008-2009 Texas Instruments Inc. All rights reserved. Stellaris and StellarisWare are registered trademarks of Texas Instruments. ARM and Thumb are registered trademarks and Cortex is a trademark of ARM Limited. Other names and brands may be claimed as the property of others.

Texas Instruments  
108 Wild Basin, Suite 350  
Austin, TX 78746  
Main: +1-512-279-8800  
Fax: +1-512-279-8879  
<http://www.luminarymicro.com>



TEXAS  
INSTRUMENTS



**Cortex**  
Intelligent Processors by ARM®

## IMPORTANT NOTICE

Texas Instruments Incorporated and its subsidiaries (TI) reserve the right to make corrections, modifications, enhancements, improvements, and other changes to its products and services at any time and to discontinue any product or service without notice. Customers should obtain the latest relevant information before placing orders and should verify that such information is current and complete. All products are sold subject to TI's terms and conditions of sale supplied at the time of order acknowledgment.

TI warrants performance of its hardware products to the specifications applicable at the time of sale in accordance with TI's standard warranty. Testing and other quality control techniques are used to the extent TI deems necessary to support this warranty. Except where mandated by government requirements, testing of all parameters of each product is not necessarily performed.

TI assumes no liability for applications assistance or customer product design. Customers are responsible for their products and applications using TI components. To minimize the risks associated with customer products and applications, customers should provide adequate design and operating safeguards.

TI does not warrant or represent that any license, either express or implied, is granted under any TI patent right, copyright, mask work right, or other TI intellectual property right relating to any combination, machine, or process in which TI products or services are used. Information published by TI regarding third-party products or services does not constitute a license from TI to use such products or services or a warranty or endorsement thereof. Use of such information may require a license from a third party under the patents or other intellectual property of the third party, or a license from TI under the patents or other intellectual property of TI.

Reproduction of TI information in TI data books or data sheets is permissible only if reproduction is without alteration and is accompanied by all associated warranties, conditions, limitations, and notices. Reproduction of this information with alteration is an unfair and deceptive business practice. TI is not responsible or liable for such altered documentation. Information of third parties may be subject to additional restrictions.

Resale of TI products or services with statements different from or beyond the parameters stated by TI for that product or service voids all express and any implied warranties for the associated TI product or service and is an unfair and deceptive business practice. TI is not responsible or liable for any such statements.

TI products are not authorized for use in safety-critical applications (such as life support) where a failure of the TI product would reasonably be expected to cause severe personal injury or death, unless officers of the parties have executed an agreement specifically governing such use. Buyers represent that they have all necessary expertise in the safety and regulatory ramifications of their applications, and acknowledge and agree that they are solely responsible for all legal, regulatory and safety-related requirements concerning their products and any use of TI products in such safety-critical applications, notwithstanding any applications-related information or support that may be provided by TI. Further, Buyers must fully indemnify TI and its representatives against any damages arising out of the use of TI products in such safety-critical applications.

TI products are neither designed nor intended for use in military/aerospace applications or environments unless the TI products are specifically designated by TI as military-grade or "enhanced plastic." Only products designated by TI as military-grade meet military specifications. Buyers acknowledge and agree that any such use of TI products which TI has not designated as military-grade is solely at the Buyer's risk, and that they are solely responsible for compliance with all legal and regulatory requirements in connection with such use.

TI products are neither designed nor intended for use in automotive applications or environments unless the specific TI products are designated by TI as compliant with ISO/TS 16949 requirements. Buyers acknowledge and agree that, if they use any non-designated products in automotive applications, TI will not be responsible for any failure to meet such requirements.

Following are URLs where you can obtain information on other Texas Instruments products and application solutions:

### Products

Amplifiers	<a href="http://amplifier.ti.com">amplifier.ti.com</a>
Data Converters	<a href="http://dataconverter.ti.com">dataconverter.ti.com</a>
DLP® Products	<a href="http://www.dlp.com">www.dlp.com</a>
DSP	<a href="http://dsp.ti.com">dsp.ti.com</a>
Clocks and Timers	<a href="http://www.ti.com/clocks">www.ti.com/clocks</a>
Interface	<a href="http://interface.ti.com">interface.ti.com</a>
Logic	<a href="http://logic.ti.com">logic.ti.com</a>
Power Mgmt	<a href="http://power.ti.com">power.ti.com</a>
Microcontrollers	<a href="http://microcontroller.ti.com">microcontroller.ti.com</a>
RFID	<a href="http://www.ti-rfid.com">www.ti-rfid.com</a>
RF/IF and ZigBee® Solutions	<a href="http://www.ti.com/lprf">www.ti.com/lprf</a>

### Applications

Audio	<a href="http://www.ti.com/audio">www.ti.com/audio</a>
Automotive	<a href="http://www.ti.com/automotive">www.ti.com/automotive</a>
Broadband	<a href="http://www.ti.com/broadband">www.ti.com/broadband</a>
Digital Control	<a href="http://www.ti.com/digitalcontrol">www.ti.com/digitalcontrol</a>
Medical	<a href="http://www.ti.com/medical">www.ti.com/medical</a>
Military	<a href="http://www.ti.com/military">www.ti.com/military</a>
Optical Networking	<a href="http://www.ti.com/opticalnetwork">www.ti.com/opticalnetwork</a>
Security	<a href="http://www.ti.com/security">www.ti.com/security</a>
Telephony	<a href="http://www.ti.com/telephony">www.ti.com/telephony</a>
Video & Imaging	<a href="http://www.ti.com/video">www.ti.com/video</a>
Wireless	<a href="http://www.ti.com/wireless">www.ti.com/wireless</a>

Mailing Address: Texas Instruments, Post Office Box 655303, Dallas, Texas 75265  
Copyright © 2009, Texas Instruments Incorporated